

Parts & Service



Spray Star 1600P
14-300
SN: SS1272

October 2010
Updated August 2012

Product Support:

Hwy 55 & Poplar Ave; Cameron WI 54822
1-800-891-9435 productsupport@smithco.com

CONTENTS

Introduction

Service

Diagrams

Parts

Accessories

Reference

Introduction 1-3

Introduction	1
General Safe Practices	2
Specifications	3
Optional Spray Equipment	3

Service 4-12

Maintenance	4-6
Axle Shaft Disassembly	7-8
Axle Shaft Assembly	8-9
Service Chart	10
End User's Service Chart	11
Adjustments	12
Storage	12

Diagrams 14-17

Hydraulic Diagram	14-15
Wiring Diagram	16-17

Parts 18-55

Body & Frame	18-19
Tank & Rear Fenders	20-21
Nose Cone	22-25
Brake	26-27
Pumps And Exhaust	28-29
Spray Pump	30-31
Front Axle	32-33
Clutch Linkage	34-35
Engine and Control Panel	36-39
Gas Tank	40-41
Turbo Quad Agitator	42-43
14-521 Strainer	42-43
15-301 Orbitor	44-45
15-409 3-Speed Transmission	46-49
16-998 Hypro® Pump	50-51
16-037 Rear Axle	52-53
Brake Assembly	54-55

Accessories 56-104

Plumbing 1602P System (Raven 440)	56-57
Plumbing 1604P System (Raven 203)	58-59
Plumbing 1610P System (Manual)	60-61
Controls 1602P System (Raven 440)	62
Control 1604P System (Raven 203)	63
16-524 Motorized Control Valve	64
14-521 Strainer	65
10-268 3-Way Manual Valve	66-67
15-552 Control Valve	68-69
10-160 Stainless Steel Wet Boom	70-73
Nozzle Assembly	74
Turbo TurfJet Tips	75
XR TEEJET Tips	75
15-525 18' Smithco Super Boom	76-77
15-550 15.5' Smithco Super Boom	78-79
Triple Nozzle	80
16-129 Manual Hose Reel	81
16-906 Electric Hose Reel	82-83
Electric Hose Reel Wiring Diagram	84
Hose Reel Adjustments	85
14-308 Hose Reel Mount for 17-525/17-550	86-87
14-283 Foam Marker Installation	88-94
15-511 Foam Nozzle Sub Assembly	95
15-363 Fresh Water Tank For 1602P and 1604P	96
10-106 Fresh Water Tank For 1610P	97
14-515/15-618 Water Meter Kit	98
15-835 Tank Rinsing System	99
10-366 Chemical Clean Load	100-104

Reference 105-106

Decal List	105
Quick Reference Replacement Parts	106
Limited Warranty	

Thank you for purchasing a **SMITHCO** product.

Read this manual and all other manuals pertaining to the Spray Star carefully as they have safety, operating, assembly and maintenance instructions. Failure to do so could result in personal injury or equipment damage. Keep manuals in a safe place after operator and maintenance personnel have read them. Right and left sides are from the operator's seat, facing forward.

All **SMITHCO** machines have a Serial Number and Model Number. Both numbers are needed when ordering parts. The serial number plate on the Spray Star is located on the front left side of the main frame. Refer to engine manual for placement of engine serial number.

For easy access record your Serial and Model numbers here.

SMITHCO			CE
WAYNE, PENNSYLVANIA 19087 USA 610-688-4009 Fax 610-688-6069			
SERIAL NO.	kW/hp	DATE OF MFG.	
<input type="text"/>	<input type="text"/>	<input type="text"/>	
MODEL NO.	lb/kg Empty	lb/kg Full	
<input type="text"/>	<input type="text"/>	<input type="text"/>	



Information needed when ordering replacement parts:

1. Model number of machine.
2. Serial number of machine.
3. Name and part number of part.
4. Quantity of parts.

GENERAL SAFE PRACTICES

1. It is your responsibility to read this manual and all publications associated with this machine.
2. Never allow anyone to operate or service the machine or its optional equipment without proper training and instructions. Never allow minors to operate any equipment.
3. Learn the proper use of the machine, the location and purpose of all the controls and gauges before you operate the equipment. Working with unfamiliar equipment can lead to accidents.
4. Wear all the necessary protective clothing and personal safety devices to protect your head, eyes, ears, hands and feet. Operate the machine only in daylight or in good artificial light.
5. Inspect the area where the equipment will be used. Pick up all debris you can find before operating. Beware of overhead obstructions and underground obstacles. Stay alert for hidden hazards.
6. Never operate equipment that is not in perfect working order or without decals, guards, shields, or other protective devices in place.
7. Never disconnect or bypass any switch.
8. Carbon monoxide in the exhaust fumes can be fatal when inhaled, never operate a machine without proper ventilation.
9. Fuel is highly flammable, handle with care.
10. Keep engine clean. Allow the engine to cool before storing and always remove the ignition key.
11. Disengage all drives and set park brake before starting the engine.
12. Never use your hands to search for oil leaks. Hydraulic fluid under pressure can penetrate the skin and cause serious injury.
13. This machine demands your attention. To prevent loss of control or tipping of the vehicle:
 - A. Use extra caution in backing up the vehicle. Ensure area is clear.
 - B. Do not stop or start suddenly on any slope.
 - C. Reduce speed on slopes and in sharp turns. Use caution when changing directions on slopes.
 - D. Stay alert for holes in the terrain and other hidden hazards.
14. Before leaving operator's position:
 - A. Disengage all drives.
 - B. Set park brake.
 - C. Shut engine off and remove the ignition key.
 - D. If engine has to run to perform any maintenance keep hands, feet, clothing and all other parts of body away from moving parts.
15. Keep hands, feet and clothing away from moving parts. Wait for all movement to stop before you clean, adjust or service the machine.
16. Keep the area of operation clear of all bystanders.
17. Never carry passengers.
18. Stop engine before making repairs/adjustments or checking/adding oil to the crankcase.
19. Use parts and materials supplied by **SMITHCO** only. Do not modify any function or part.
20. Use caution when booms are down as they extend out beyond the center line of the machine approximately 10 ft. (3 m).
21. The tank is a confined space, take precaution.

These machines are intended for professional maintenance on golf courses, sports turf, and any other area maintained turf and related trails, paths and lots. No guaranty as to the suitability for any task is expressed or implied.

SPECIFICATIONS SPRAY STAR 1600P

WEIGHTS AND DIMENSIONS

Length	112" (285 cm)		
Width	61" (155 cm)	Width With Booms Down	230" (584 cm)
Height	50" (127 cm)	Height With Booms Up	126" (320 cm)
Wheel Base	60" (152 cm)		
Weight Empty	1200 lb (544 kg)		
Weight Loaded	2500 lb (1134 kg)		

SOUND LEVEL AT 3400 RPM

At ear level	84 dB
At 3 ft. (0.914 m)	82 dB
At 30 ft (9.14 m)	68 dB
At 23 ft (7 m) pass by	70 dB

ENGINE

Make	Kohler
Model#	Command CH20S
Type / Spec#	64558
Horsepower	20 hp (15 kW)
Fuel	Unleaded 87 Octane Gasoline Minimum
Cooling System	Air cooled
Lubrication System	Full pressure
Alternator	25 Amp

WHEELS & TIRE

Front (2) 20 x 1000 x 10 Multi-rib 20 psi (1.4 bar)
 Rear (2) 24 x 1300 x 12 Super Soft 18 psi (1.3 bar)
 Ground Pressure: 8.2 psi with 160 gallons

SPEED

Working Speed	1st gear 0-3 m.p.h. (0-5 kph) 2nd gear 2-6 m.p.h. (3-10 kph)
Transport Speed	3rd gear 4-10 m.p.h. (6-16 kph)
Reverse Speed	0-3 m.p.h. (0-5 kph)

BATTERY

	Automotive type 24F-12 volt
BCI Group	Size 24
Cold Cranking Amps	575 minimum
Ground Terminal Polarity	Negative (-)
Maximum Length	10.25" (26 cm)
Maximum Width	6.88" (17 cm)
Maximum Height	10" (25 cm)

FLUID CAPACITY

Crankcase Oil	2.1 quart (2 liters) with filter
Fuel	6 gallon (22.7 liters)
Hydraulic Fluid	1 gallon (3.785 liters)
Grade of Fluid	SAE 10W-40 API Service SJ or higher motor oil

OPTIONAL SPRAY EQUIPMENT

33-216	Battery 24F-12 Volt	15-363	Fresh Water Wash Tank
10-366	Chemical Cleanload	14-308	Hose Reel mount Kit f/HD Booms
14-311	Hose Reel Mounting Kit	15-493	Auto-Boom 18' (5.5 m) Long
14-515	Water Meter Kit (gallons)	15-618	Water Meter Kit (liter)
1602P	440 Spray System	17-525	18.5 ft Triple Nozzle HD Boom
1604P	203 Spray System	15-835	Tank Rinsing System
1610P	Manual Spray System	14-283	Foam Marker System (Factory Installed)
14-285	Foam Marker System (Dealer Installed)	17-550	15 ft Triple Nozzle HD Boom
16-906	Electric Rewind Hose Reel, 200-ft/61m capacity		
16-129	Manual Rewind Hose Reel, 200-ft/61m capacity		



MAINTENANCE



Before servicing or making adjustments to machine, stop engine and remove key from ignition. When servicing the spray pump or filter all control valves must be shut off if there is liquid in the tank.

NOTE:

Use all procedures and parts prescribed by the manufacturer's. Read the engine manual before operation.

The suggested maintenance checklist is not offered as a replacement for the manufacturer's but as a supplement. You must adhere to guidelines established by manufacturer for warranty coverage. In adverse conditions such as dirt, mud or extreme temperatures, maintenance should be more frequent.

LUBRICATION

Use No. 2 General purpose Lithium Base Grease and lubricate every 100 hours. The Spray Star 1600P has 7 grease fittings.

- One on the rod end of hydraulic cylinder.
- One on each the right and left spindles.
- One on the front axle.
- One on clutch idler arm.
- One on each end of the drive line.

AIRCLEANER

- Loosen cover retaining knob and remove cover.
- Remove precleaner from paper element.
- Check paper element. Replace element as necessary.
- Wash precleaner in warm water with detergent. Rinse precleaner thoroughly until all traces of detergent are eliminated. Squeeze out excess water (do not wring). Allow precleaner to air dry.
- Saturate precleaner with new engine oil. Squeeze out all excess oil.
- Reinstall precleaner over paper element.
- Reinstall air cleaner cover. Secure cover with cover retaining knob.

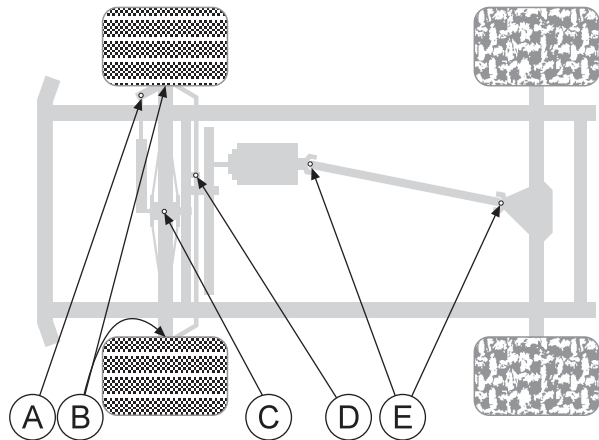

HYDRAULIC OIL

- Use SAE 10W-40 API Service SJ or higher motor oil.
- For proper warranty, change oil every 500 hours or annually, which ever is first.
- Oil level should be 1.5" (4 cm) from top of tank when fluid is cold. Do not overfill.
- After changing oil, run the machine for a few minutes. Check oil level and for leaks.
- Always use extreme caution when filling hydraulic oil tank or checking level to keep system free of contaminants. Check and service more frequently when operating in extremely cold, hot or dusty conditions.
- If the natural color of the fluid has become black or smells burnt, it is possible that an overheating problem exists.
- If fluid becomes milky, water contamination may be a problem.
- If either of the above conditions happen, change oil immediately after fluid is cool and find the cause. Take fluid level readings when the system is cold.
- In extreme temperatures you can use straight weight oil. We recommend SAE 30W API Service SJ or higher when hot (above 90°F (33°C)) and SAE 10W API Service SJ or higher when cold (below 32°F (0°C) ambient temperature. Use either motor oil or hydraulic oil, but do not mix.

- Oil being added to the system must be the same as what is already in the tank. Mark the tank fill area as to which type you put in.



ENGINE OIL

Change and add oil according to chart below based on air temperature at the time of operation. Do not overfill. Use a high quality detergent oil classified "For Service SJ or higher" oil. Use no special additives with recommended oils. Do not mix oil with gasoline.

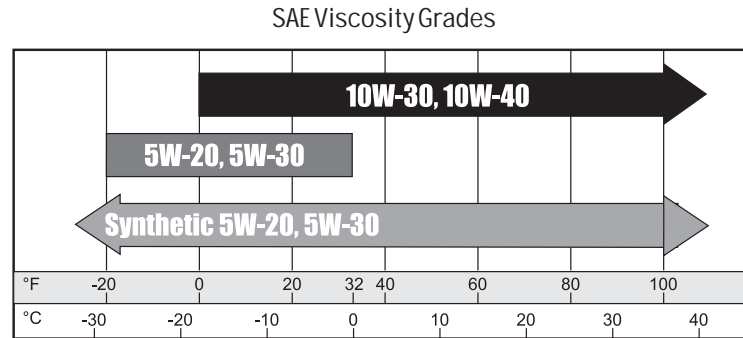

Starting Temperature Range Anticipated Before Next Oil Change

DIRECTO VALVES

Directo Valves should be disassembled, cleaned, inspected, and a service kit installed annually. More often depending on the chemicals being used and the frequency of use. In most cases this can be done without removing the valve from the sprayer.

HYPRO PUMP

1. After use, flush pump with clean water.
2. Hypro diaphragm pumps come with oil in the crankcase. Hypro recommends changing oil after 40 hours of break-in operation and every three months or 500 hours, whichever comes first. Hypro recommends a high grade, nondetergent, SAE 30 weight oil.
3. For winter storage or if a freezing condition will be encountered, flush pump with a 50/50 mixture of water and antifreeze.

DIAPHRAGM AND VALVE REPLACEMENT

1. Occasionally debris can cause the valves to not seal properly or damage the O-rings.
2. To check for this remove the pump manifold. With manifold removed, valves can readily be removed and checked for debris or wear. To replace valves or o-rings, refer to the Parts List for appropriate kits.
3. Hypro recommends changing diaphragms every 500 hours or three months, whichever comes first.
4. Drain the oil from the pump by removing drain plug. Rotate the shaft to remove excess oil.
5. Remove the pump manifold, remove the diaphragm retaining bolt, support washer and diaphragm. To replace the diaphragms order appropriate repair kit from parts list.
6. Turn the crankshaft to bring the piston to its upstroke to replace the diaphragm. Use the downstroke to seat the new diaphragm into the sleeve groove. Install retaining washer and tighten nut.
7. Replace the pulsation dampener diaphragm by first bleeding the air from the dampener. After replacing the diaphragm recharge dampener to 20% of operating pressure.
8. Refill crankcase with oil. Rotate shaft slowly forward and reverse to distribute oil and fill to proper level.

MAINTENANCE (CONTINUED)

TIRE PRESSURE

Caution must be used when inflating a low tire to recommended pressure. Over inflating can cause tires to explode. Front tires should be 20 psi (1.4 bar) and rear tires should be 18 psi (1.3 bar). Improper inflation will reduce tire life considerably.

WHEEL MOUNTING PROCEDURE

1. Set park brake. Turn machine off and remove key.
2. Block wheel on opposite corner.
3. Loosen nuts slightly on wheel to be removed.
4. Jack up machine being careful not to damage underside of machine.
5. Place wheel on hub lining up bolt holes.
6. Torque to 64-74 ft/lb (87-100 Nm) using a cross pattern. Torque again after first 10 hours and every 200 hours thereafter.
7. Lower machine to ground and remove blocks and jack.

BATTERY

Batteries normally produce explosive gases which can cause personal injury. Do not allow flames, sparks or any ignited objects to come near the battery. When charging or working near battery, always shield your eyes and always provide proper ventilation.

Battery cable should be disconnected before using "Fast Charge".

Charge battery at 15 amps for 10 minutes or 7 amps for 30 minutes. Do not exceed the recommended charging rate. If electrolyte starts boiling over, decrease charging.

Always remove grounded (-) battery clamp first and replace it last. Avoid hazards by:

1. Filling batteries in well-ventilated areas.
2. Wear eye protection and rubber gloves.
3. Avoid breathing fumes when electrolyte is added.
4. Avoid spilling or dripping electrolyte.



WARNING

Battery Electrolyte is an acidic solution and should be handled with care. If electrolyte is splashed on any part of your body, flush all contact areas immediately with liberal amounts of water. Get medical attention immediately.

JUMP STARTING

To jump start (negative grounded battery):

1. Shield eyes.
2. Disconnect computer supply leads.
3. Connect ends of one cable to positive (+) terminals of each battery, first (A) then (B).
4. Connect one end of other cable to negative (-) terminal of "good" battery (C).
5. Connect other end of cable (D) to engine block on unit being started (NOT to negative (-) terminal of battery)

To prevent damage to other electrical components on unit being started, make certain that engine is at idle speed before disconnecting jumper cables.

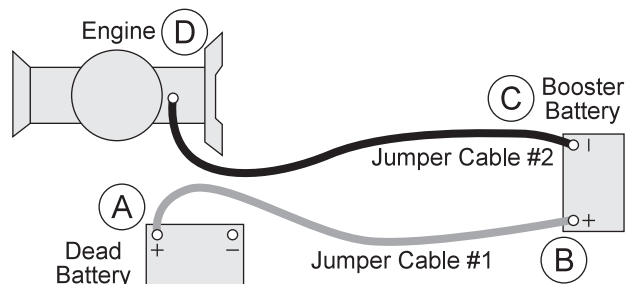

WARNING

Use of booster battery and jumper cables. Particular care should be used when connecting a booster battery. Use proper polarity in order to prevent sparks.

AXLE SHAFT DISASSEMBLY



1. After the wheel is removed, remove the brake drum.

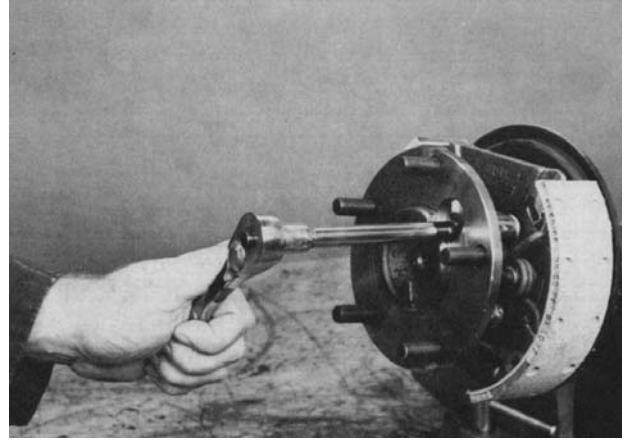

2. Using a $\frac{1}{2}$ " socket, line up the hole in the axle shaft flange to remove the backing plate nuts which hold the axle shaft assembly to the axle.



3. To remove the axle shaft assembly, grasp the axle shaft assembly with both hands (the assembly includes axle shaft, oil seal, brake assembly, gasket, bearing, and retainer) and pull the axle shaft free.

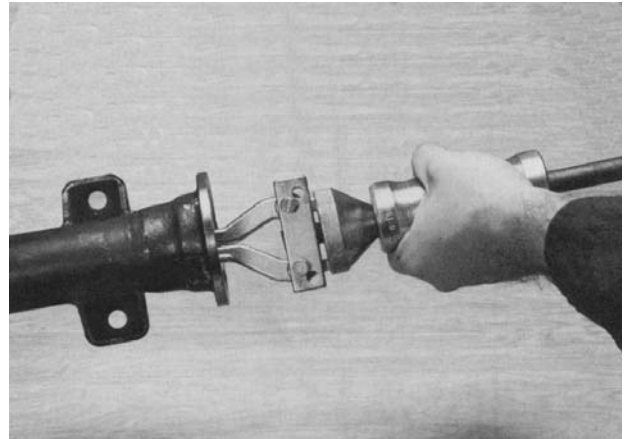

4. Remove inner Axle shaft seal using puller as shown. Discard Seal and replace with new one at time of assembly.



5. Place Axle shaft assembly in a vise. Center punch the outside of the retaining ring.

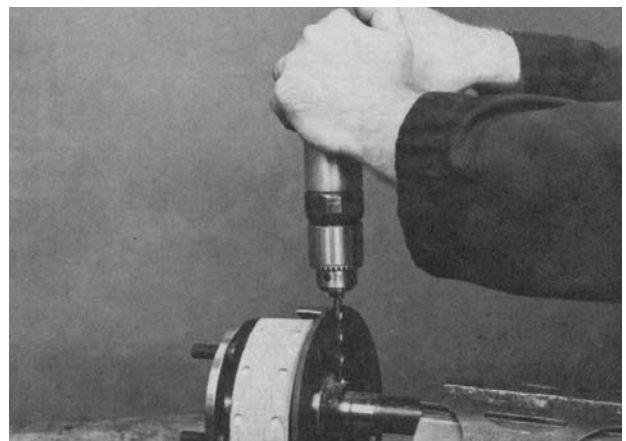

6. Drill a $\frac{1}{4}$ " hole in the outside of the retainer ring to a depth approximately $\frac{3}{4}$ the thickness of the ring. Drilling Completely through retainer ring will damage the shaft.

AXLE SHAFT DISASSEMBLY (CONTINUED)

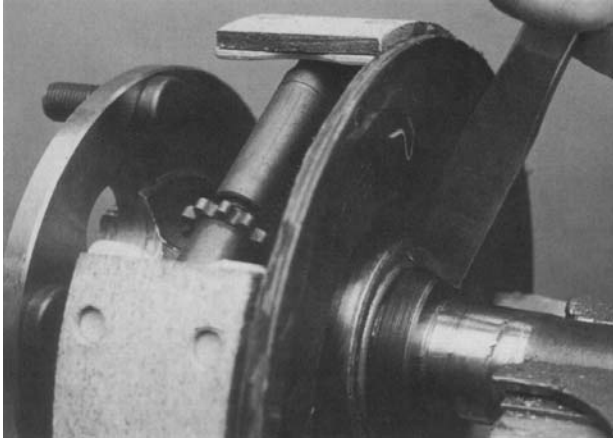

7. After drilling, position a chisel across the hole and strike sharply to break the ring. Replace with a new retaining ring when reassembly.

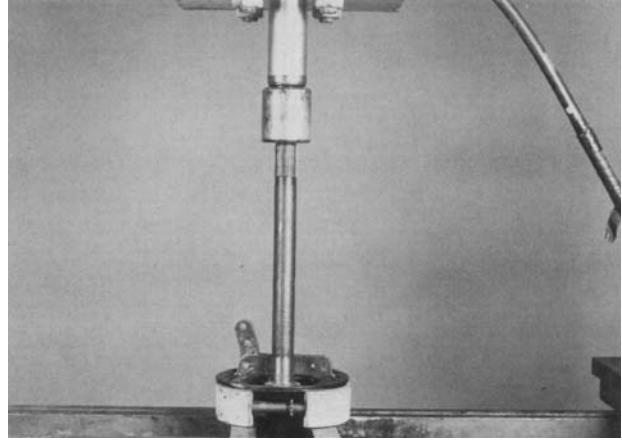

8. Support the axle shaft assembly in a suitable press. Press on the end of the axle shaft until the wheel bearing and brake assembly is removed.

AXLE SHAFT ASSEMBLY

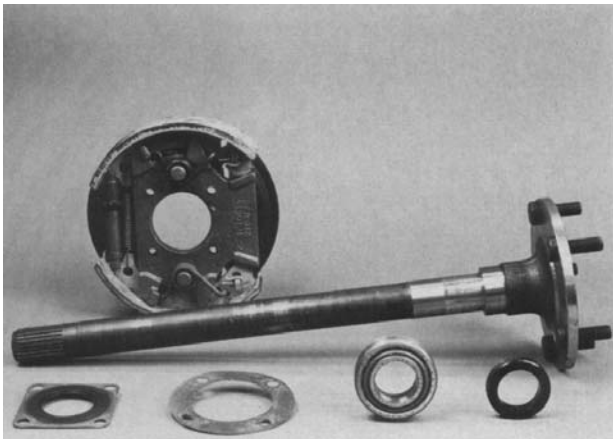

1. Inspect the shaft for possible damage. In the following order, place new oil seal, brake assembly, new grease packed bearing assembly (with unit bearing rib ring toward fanged end of shaft) on the axle shaft. The retaining ring will be placed on the shaft later.

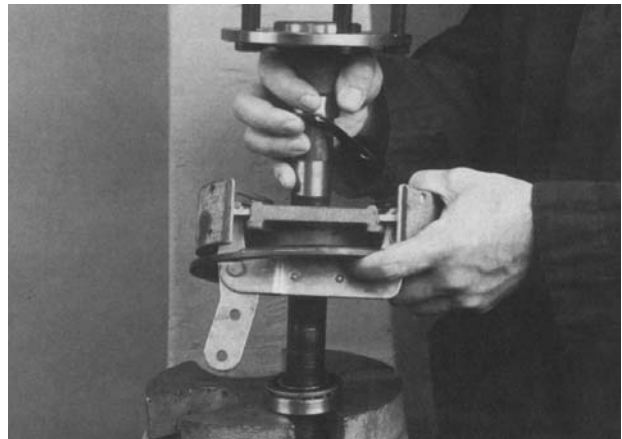

2. Support the bearing assembly in a suitable press.

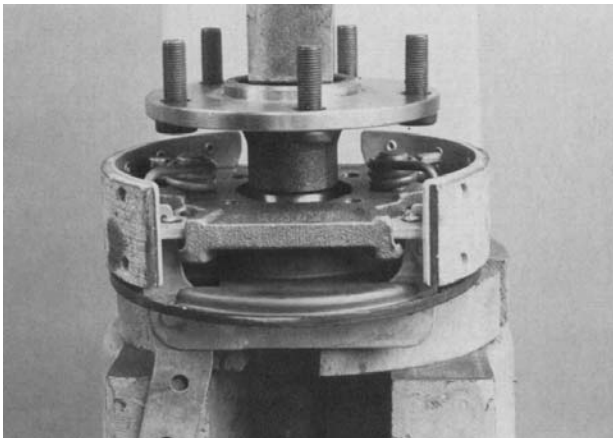

3. Press assembly until bearing is firmly seated against axle shaft shoulder.

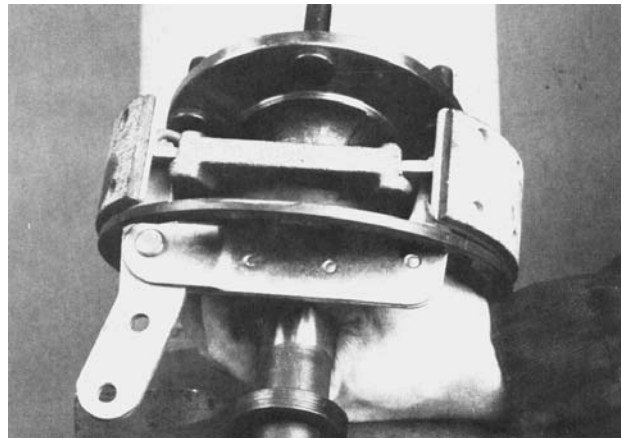

4. Slide new retaining ring on the axle shaft and support the shaft in suitable press.

AXLE SHAFT ASSEMBLY (CONTINUED)

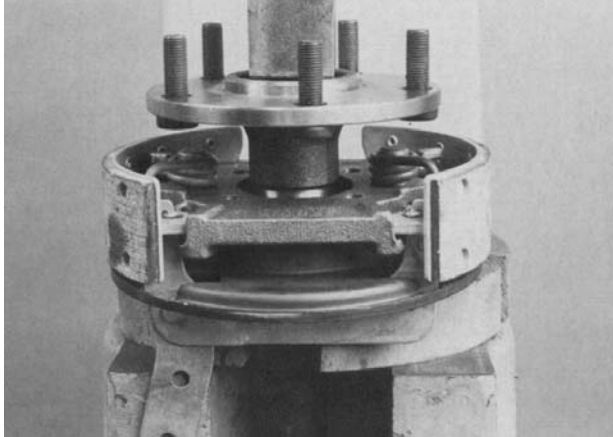

5. Press the retaining ring firmly against bearing.

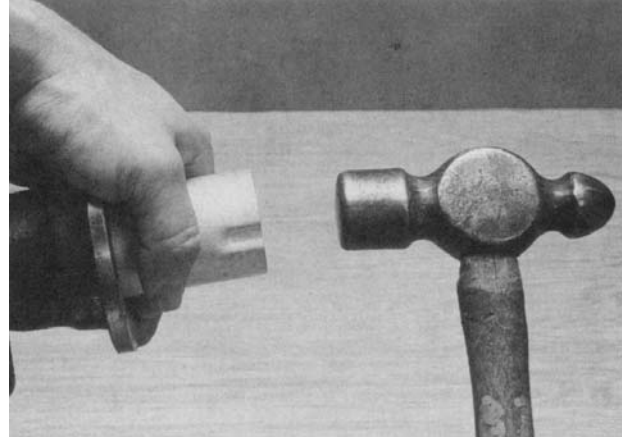

6. Assemble new grease seal into housing to original depth. After seal has been assembled, grease lip of seal.

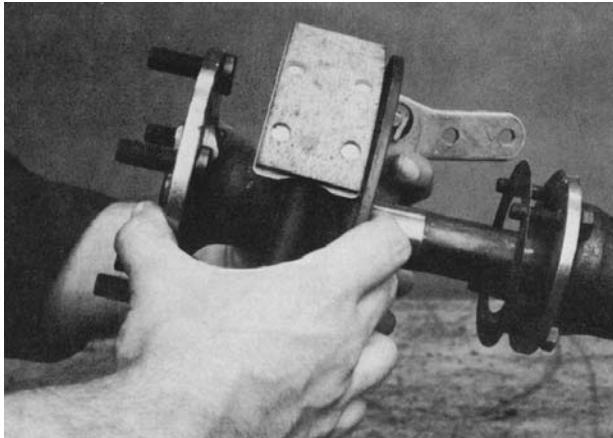

7. Assemble bearing retainer bolts and new gasket on axle housing. Then install axle shaft assembly into axle housing. Care should be taken not to damage gasket, oil seal, and bearing. Line up holes of brake assembly and oil seal. Push axle shaft as far as possible into axle housing.

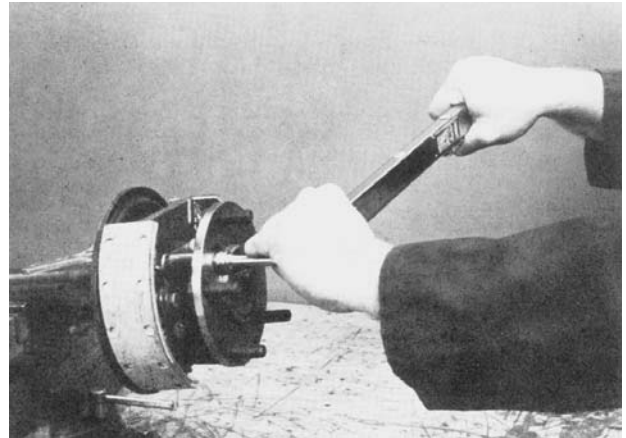

8. Start nuts on bolts by hand. Tighten nuts in a manner that assures the seal and bearing assembly are drawn evenly into axle housing. Use a torque wrench and torque nuts to 16-20 ft/lb (21-27Nm)

SERVICE CHART



Before servicing or making adjustments to the machine, stop engine, set park brak and remove key from ignition.



Follow all procedureds and **ONLY** use parts prescribed by the manufacturer. Read the engine manual before maintenance.

The suggested maintenance checklist is not offered as a replacement for the manufacturer's engine manual but as a supplement. You must adhere to the guidelines established by the manufacturer for warranty coverage. In adverse conditions such as dirt, mud or extreme temperatures, maintenance should be more frequent.

Before each use daily	<ul style="list-style-type: none"> Check the engine oil. Check the hydraulic fluid level. Check the tire pressure. Check fuel level Check condition of hydraulic hoses and fittings. Inspect and clean the machine. Flush spray system tank. Inspect cooling system.
Every 100 hours	<ul style="list-style-type: none"> Change the engine oil and filter. Check hydraulic filter Check engine for leaks or loose parts. Check spark plugs Check air cleaner. Check tire pressure (20 psi (1.4 bar)). Check the battery fluid level and cable connections. Torque the wheel lug nuts. (64-74 ft/lb (87-100 Nm)) Grease Machine. Check belt tension (where needed)
Every 200 Hours	<ul style="list-style-type: none"> Change oil filter Torque the wheel lug nuts. (64-74 ft/lb (87-100 Nm))
Every 250 hours	<ul style="list-style-type: none"> Check Idle Speed Change hydraulic filter Clean battery terminals
Every 400 hours	<ul style="list-style-type: none"> Check spark plugs
Every 500 hours or yearly	<ul style="list-style-type: none"> Lubricate machine Visual inspection of machine and hydraulic hoses Change oil. Torque lug nuts. Check battery terminals and electrolyte level. Change all filters.

END USER'S SERVICE CHART

Duplicate this page for routine use

Maintenance Check Item	For the week of:						
	Mon	Tues.	Wed.	Thurs.	Fri.	Sat.	Sun.
Check the Safety Seat Switch							
Check Steering Operation							
Check the fuel level							
Check the engine oil level.							
Check the condition of the air filter							
Clean the engine cooling fins.							
Check for unusual engine noises							
Check the hydraulic oil level							
Check hydraulic hoses and fittings for damage							
Check for fluid leaks.							
Check the tire pressure (20-30 psi)							
Check the Instrumentation							
Inspect electrical system for frayed wires							
Check neutral start							
Change oil filter.							
Change oil.							
Lubricate Machine							
Ensure all warning decals are intact.							

Areas of Concern		
Inspection Performed by:		
Item	Date	Information

Service

ADJUSTMENTS

INTERLOCK SWITCH

Located on the front, below the floorboard and behind the clutch. The Interlock Switch is in the electrical circuit between the starter solenoid and the starter on the ignition switch. When the clutch pedal is depressed, it pushes the plunger on the interlock switch in, which creates a circuit. Thus allowing the engine to start. When the clutch pedal is released the plunger on the interlock switch comes out, which breaks the circuit. To adjust, loosen the two nuts holding the interlock switch and move the interlock switch towards or away from the clutch pedal as needed.

HYDRAULIC POWER UNIT BELT

Located to the rear and left of the engine. Should have approximately $\frac{1}{4}$ " (6.5 mm) of deflection in the center of the top strand. To adjust, loosen the bolt holding the hydraulic power unit bracket to the frame and adjust the belt tension as required. Retighten the bolt after the adjustments made.

FOOT CLUTCH BELT

See belt and pulley drawing in this book. Belt retainer should be adjusted so that there is $\frac{1}{8}$ " to $\frac{1}{4}$ " (3.25 to 6.5 mm) clearance between the belt and retainer with the clutch fully engaged. This is just a starting point. Start the engine with the transmission in neutral and the park brake set. Engage and disengage the clutch, check to see if the belt has stopped and is against the retainers. If not shut engine off and readjust the retainers. Adjust the clutch rods as required to shorten, turn the ball joints in and out to lengthen.

SPRAY PUMP

Located to the rear and left of the engine. Should have approximately $\frac{1}{2}$ " (13 mm) of deflection in the center of the top strand. Loosen and tighten the $\frac{3}{8}$ - x $2\frac{1}{2}$ set screw located on the frame pushing against the pump arm.

PARK BRAKE

Adjust on lever. Adjust on clevis.

BRAKES

Can be adjusted from outside of brake drum with a brake tool.

MASTER BOOM SWITCH (FOOT SWITCH)

The master boom switch, located on the left floorboard is used to override the master switch on the computer console of the spray systems. By pushing down it will turn on/off the booms. *For the 440 System* the Master Switch on the computer **must be off** for the master boom control switch to work.

GROUND SPEED CONTROL (FOOT SWITCH)

The ground speed control does not work the same as an automotive type cruise. The ground speed control is located on the center floorboard and is used to lock forward speed.

TO ENGAGE:

1. Flip rocker switch 'On' (green light).
2. Obtain desired speed with foot pedal.
3. Step on foot switch to lock speed.
4. Push foot switch again to disengage.

SPEED CALIBRATION NUMBERS

The speed calibration number for the Spray Star 1602 is 114. This is measured off the drive shaft.

The speed calibration number for the Spray Star 1607 is 621. This is measured off the drive shaft.

If the engine will be out of service for two or more months, use the following storage procedure.

1. Clean the exterior surfaces of the engine.
2. Change the oil and filter while the engine is still warm from operation.
3. The fuel system must be completely emptied, or the gasoline must be treated with a stabilizer to prevent deterioration.

If you choose to use a stabilizer, follow manufacturers recommendations, and add the correct amount for the capacity of fuel system. Fill fuel tank with clean, fresh gasoline. Run engine for 2-3 minutes to get stabilized fuel into carburetor. Close fuel shut-off valve when unit is being stored or transported.

To empty the system, drain fuel tank and carburetor, or run engine until tank and system are empty.

4. Remove the spark plugs. Add one tablespoon of engine oil into each spark plug hole. Install plugs, but do not connect the plug leads. Crank the engine two or three revolutions.
5. Store machine in a clean, dry place.

HYDRAULIC DIAGRAM

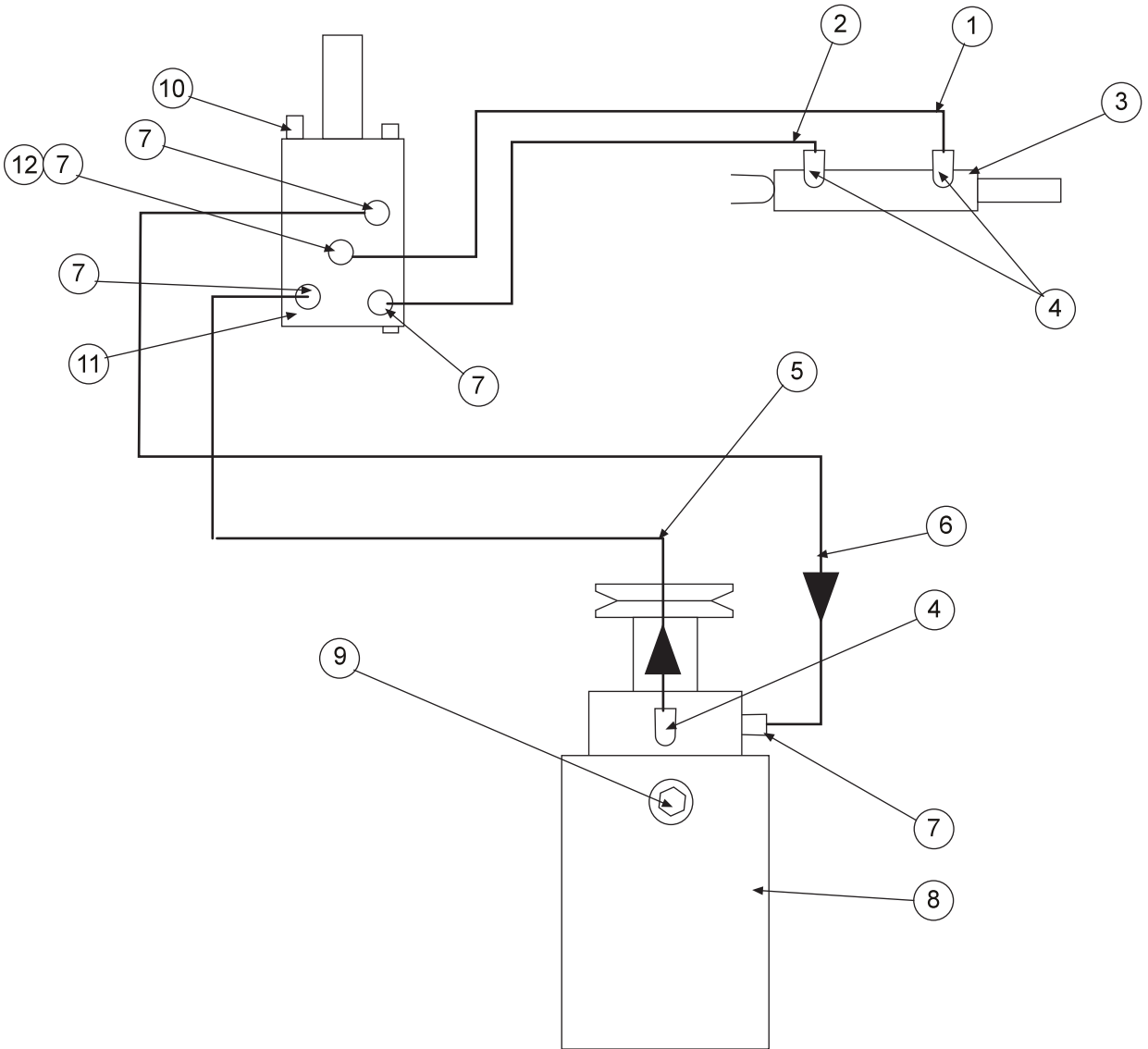

Diagrams

HYDRAULIC DIAGRAM PARTS LIST

REF#	PART#	DESCRIPTION	QUANTITY
1	14-352	Hydraulic Hose 54"	1
2	14-351	Hydraulic Hose 46"	1
3	77-263	Hydraulic Cylinder 1 $\frac{1}{2}$ x 7	1
	14-530	Seal Kit	
4	18-171	$\frac{11}{16}$ X $\frac{9}{16}$ 90° Straight Thread Elbow	3
5	14-355	Hydraulic Hose 81"	1
6	14-354	Hydraulic Hose 84"	1
7	18-306	$\frac{11}{16}$ X $\frac{9}{16}$ Straight Thread Connector	5
8	15-315	Hydraulic Power Unit	1
	15-315-01	Repair Kit	
9	27-059	Filler Breather (part of 15-315)	1
	18-314	$\frac{3}{8}$ Pipe Coupler	1
	18-287	$\frac{3}{8}$ Pipe Nipple x 2	1
10	HBM-6-16	Metric Bolt M6 - 1 x 16	4
	HWLM-6	Lockwasher M6	4
11	15-301	Orbitor	1
	15-301-01	Seal Kit	
12	18-309	Swivel Nut	1

FITTING TORQUE CHARTS

Seal-Lok Straight and Adjustable Fitting (Steel) Torque Ratings				
Fitting Size	SAE Tube Thread Size	Tube Side		Port Side
		in. lbs.	ft. lbs.	ft. lbs.
4	$\frac{9}{16}$ - 18	220	18	15
6	$\frac{11}{16}$ - 16	360	30	35
8	$\frac{13}{16}$ - 16	480	40	60
10	1-14		60	100
12	$1\frac{3}{16}$ - 12		85	135
14	$1\frac{5}{16}$ - 12		95	175
16	$1\frac{7}{16}$ - 12		110	200
20	$1\frac{11}{16}$ - 12		140	250
24	2 - 12		180	305
32	$2\frac{1}{2}$ - 12		360	375

Over tightened fittings will result in crushing the cone which will create a leak.

Charts Developed by Parker Hennipin

WIRING DIAGRAM

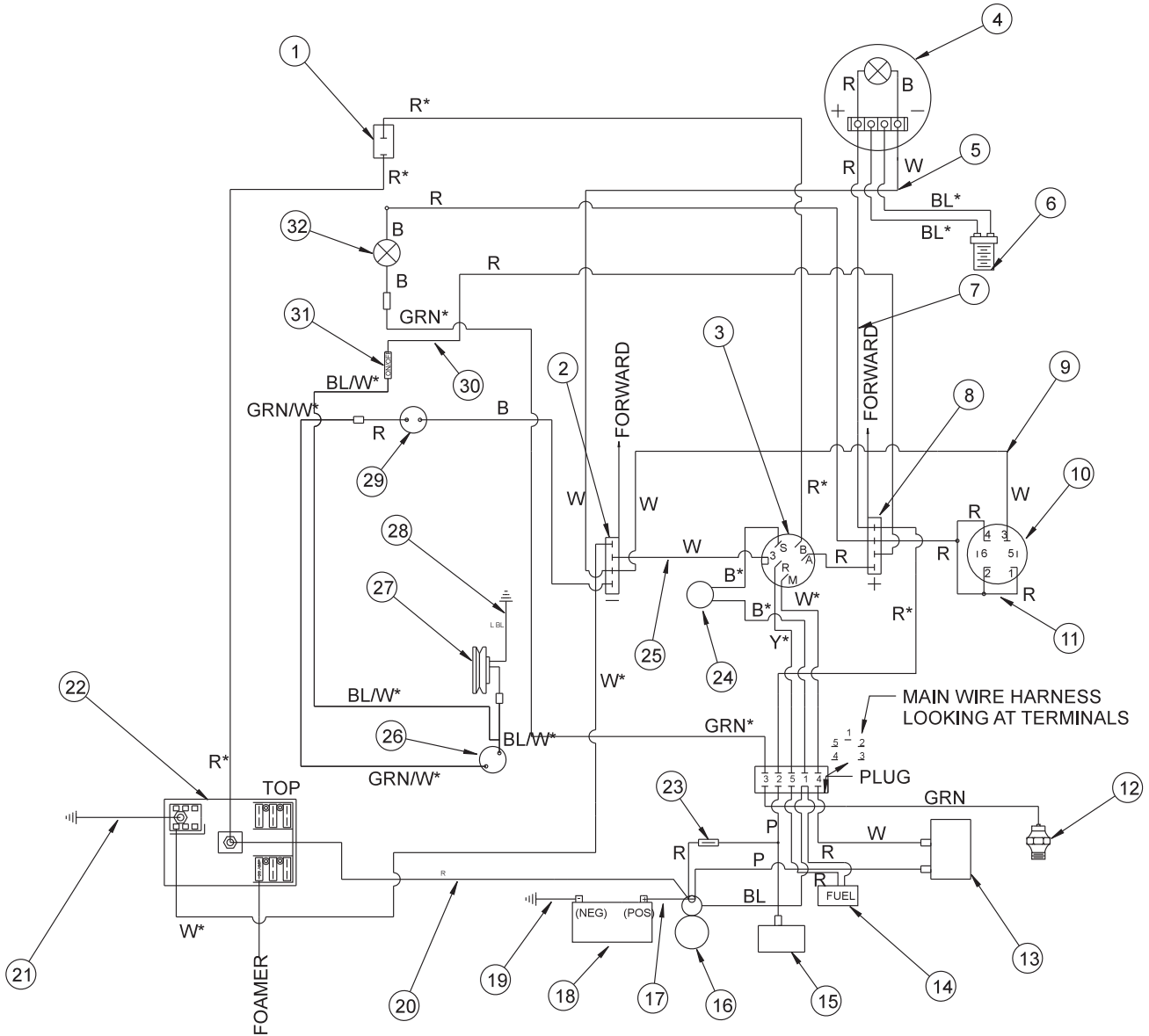

NOTE:

Use dielectric grease on all electrical connections.

To reset circuit breaker on ball valve, you must disconnect power to the computer.

FUSES		
Boom Lift	30 AMP	33-273
Spray System	15 AMP	33-508
Manifold Valve	5 AMP	33-284
Foamer	10 AMP	33-507
Hose Reel	30 AMP	33-273

Color Code Chart	
Bl	Blue
Br	Brown
Y	Yellow
Grn	Green
O	Orange
R	Red
B	Black
P	Purple
W	White
G/W	Green & White

WIRING DIAGRAM PARTS LIST

REF#	PART#	DESCRIPTION	QUANTITY
1	34-146	Panel Mounted Circuit Breaker	1
	34-145	Circuit Breaker Boot	1
2	8935	Buss Bar (-)	1
3	13-288	Ignition Switch (Kohler 25 099 04)(part of engine)	1
	76-310	Key Set	1
4	14-543	Speedometer	1
	8854	Fork Terminal	2
	8963	Heat Shrink	2
5	14-332	Speedometer Ground Wire	1
6	16-883	Magnetic Sensor (Speedometer)	1
7	14-333	Speedometer (+) Wire	1
8	8935	Buss Bar(+)	1
9	14-331	Hour / Voltmeter Ground Wire	1
10	12-017	Hourmeter	1
11	14-330	Hour / Voltmeter (+) Wire	1
12		Oil Sender (part of engine)	
13		Ignition Module (part of engine)	
14		Fuel Shut-Off Solenoid (part of engine)	
15		Rectifier (part of engine)	
16		Starter (part of engine)	
17	50-323	Red Battery Cable	1
18	33-216	Battery	1
19	22-065	Ground Battery Cable	1
20	15-484	Wire Assembly Fuse Block To + Bat. (on solenoid)	1
21	15-485	Wire Assembly Fuse Block To Ground	1
22	33-271	Fuse Block	1
23		Wire With Fuse (part of engine)	
		Fuse AGC 30	
24	22-002	Interlock Switch	1
25	14-334	Ignition Switch Ground Wire	1
26	33-480	Pressure Switch	1
27	16-998	Hypro Pump With Electric Clutch	1
	8958	Male Slide on Terminal	1
	8963	Heat Shrink	1
28	15-457	Ground Wire	1
29	77-207	Buzzer	1
	8849-3	Black Wire	1
	8860	String Connector	1
	8859	Ring Terminal ³ / ₁₆	1
	8853	Slide On Connector	1
	8963	Heat Shrink	2
30	14-335	Spray Pump Switch (+) Wire	1
31	15-314	Toggle Switch	1
	15-472	Switch Boot	1
32	50-359	Oil Warning Light	1
	8850-12	Red Wire	1
	8860	String Connector	1
	8859	Ring Terminal ³ / ₁₆	1
	8958	Male Slide On Terminal	1
	8963	Heat Shrink	2
N.S.	22-017	Cable Black (transmission to frame)	1
	14-336	Main Wire Harness (Includes all wire colors with *)	1

BODY & FRAME DRAWING

Parts

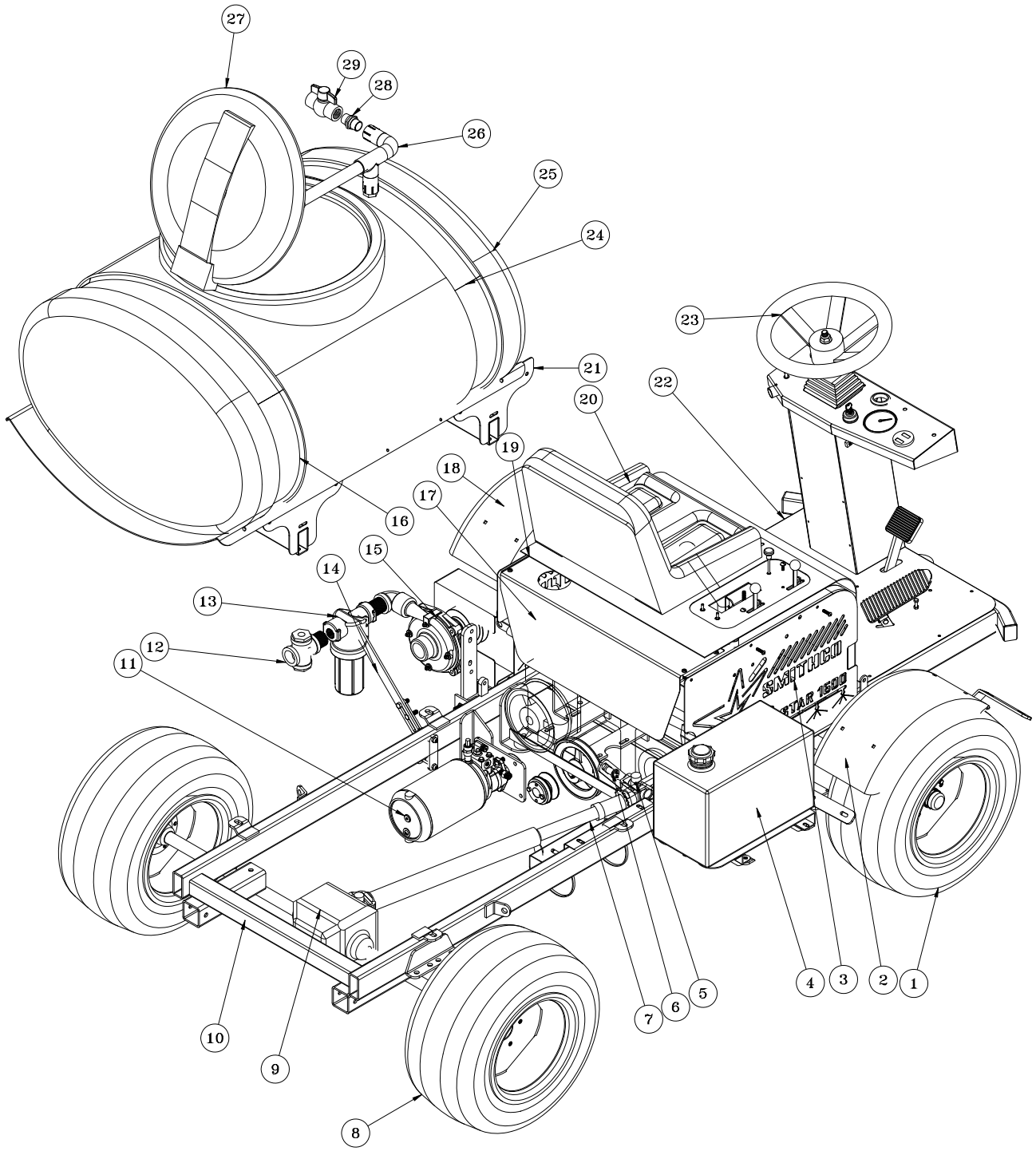

BODY & FRAME PARTS LIST

REF#	PART#	DESCRIPTION	QUANTITY
1	16-857	Front Tire & Wheel	2
	16-857-01	Tire 20 x 10.00 - 10NHS 4 Ply	2
	16-857-02	Wheel	2
	HNL-12-20	Lug Nut $1\frac{1}{2}$ - 20	10
2	10-180	Front Fender	2
3	14-350	Right Side Panel	1
	14-349	Left Side panel	1
4	15-838	CARB Gas Tank	1
5	15-182	Cross (part of 14-370)	2
	16-003-01	Strap Kit	4
6	16-883	Magnetic Sensor	1
7	14-370	Driveline (complete)	1
8	16-225	Rear Tire & Wheel	2
	16-225-01	Tire 24 x 13.00 - 12NHS 4 Ply	2
	16-225-02	Wheel	2
	HNL-716-20	Lug Nut $7\frac{7}{16}$ - 20	10
9	16-037	Axle with Brakes	1
10	14-353	Main Frame	1
11	15-315	Hydraulic Power Unit	1
	15-315-01	Repair Kit	1
12	16-976	Cross $1\frac{1}{4}$	1
13	14-521	Strainer	1
14	15-521	Top Filter Bracket	1
15	16-998	Hypro® Pump	1
16	14-322	Rear Tank Strap	1
17	14-326	Rear Engine Cover	1
18	10-180	Front Fender	2
19	15-356	Engine Cover/Seat	1
20	14-270	Seat with Adjusters	1
21	14-321	Tank Carrier	1
22	14-328	Floorboard	1
23	13-718	Steering Wheel	1
	13-726	Steering Wheel Cap	1
24	14-327	Front Tank Strap	1
25	14-451	160 Gallon Poly Tank	1
26	14-365	Air Gap Filler	1
27	16-953	16" Hinged Lid/Well with Gasket (part of tank)	1
	16-953-01	Gasket	1
	16-169	Strainer Basket 16"	1
28	16-851	1" Nipple	1
29	18-448	1" Ball Valve	1

TANK AND REAR FENDER DRAWING

Parts

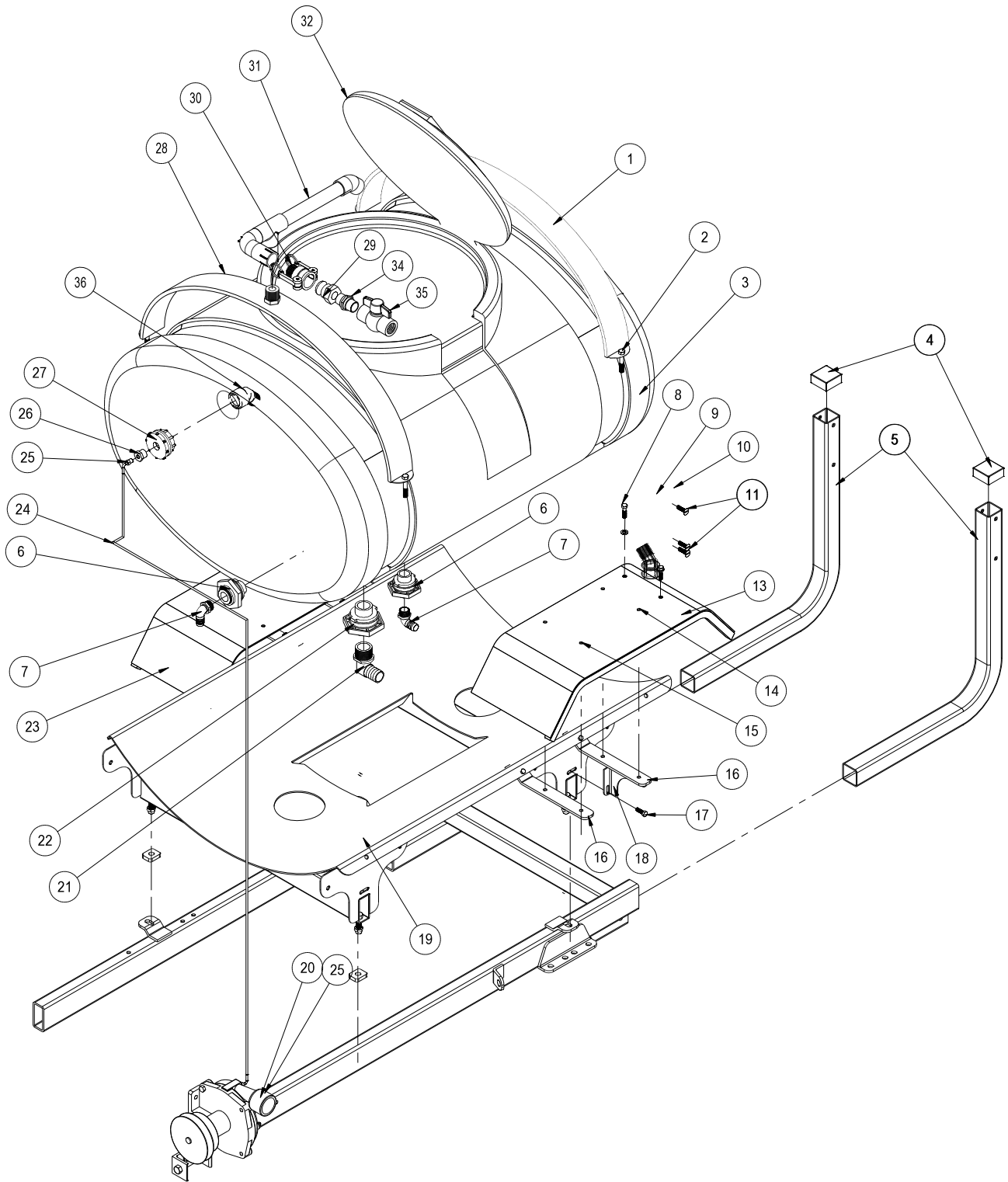

TANK AND REAR FENDER PARTS LIST

REF#	PART#	DESCRIPTION	QUANTITY
1	14-322	Rear Tank Strap	1
2	HB-38-16-250	Bolt $\frac{3}{8}$ - 16 x $2\frac{1}{2}$	4
	HNTL-38-16	Lock Nut $\frac{3}{8}$ - 16	4
3	14-451	160 Gallon Poly Tank	1
4	16-557	Square Cap	2
5	14-325	Boom Carrier	2
6	16-150	Double Threaded Fitting $\frac{3}{4}$ (bottom fitting only part of tank)	2
7	16-155	Elbow $\frac{3}{4}$ MPT x 1 HB	2
8*	HB-516-18-125	Bolt $\frac{5}{16}$ - 18 x $1\frac{1}{4}$	4
	HW-516	Washer $\frac{5}{16}$	4
	HWL-516	Lockwasher $\frac{5}{16}$	4
	HN-516-18	Nut $\frac{5}{16}$ -18	4
9*	15-328	Boom Carrier	2
10*	15-437	Latch	2
11*	HSM-8-32-150	Machine Screw #8 - 32 x $1\frac{1}{2}$	6
	HWL-8	Lockwasher #8	6
	HN-8-32	Nut #8 -32	6
13	15-447	Left Fender	1
14	HB-516-18-075	Bolt $\frac{5}{16}$ - 18 x $\frac{3}{4}$	6
	HNTL-516-18	Lock Nut $\frac{5}{16}$ - 18	6
15	HB-516-18-100	Bolt $\frac{5}{16}$ - 18 x 1	2
	HNTL-516-18	Lock Nut $\frac{5}{16}$ -18	2
16	14-324	Fender Mount	4
	HB-14-20-075	Bolt $\frac{1}{4}$ - 20 x $\frac{3}{4}$	4
	HNTL-14-20	Lock Nut $\frac{1}{4}$ - 20	4
17	HB-516-18-100	Bolt $\frac{5}{16}$ - 18 x 1	2
	HNTL-516-18	Lock Nut $\frac{5}{16}$ - 18	2
	HW-516	Washer $\frac{5}{16}$	as needed
18	14-341	Left Fender Brace	1
	14-340	Right Fender Brace	1
19	14-321	Tank Carrier	1
20	16-998	Hypro® Pump	1
21	16-156	Elbow $1\frac{1}{4}$ MPT x $1\frac{1}{4}$ HB	1
22	16-194	Anti Vortex Fitting $1\frac{1}{4}$ (part of tank)	1
23	15-446	Right Fender	1
24	8954-26	Clear Hose $\frac{3}{16}$ ID	1
25	33-494	Elbow $\frac{1}{8}$ MPT x $\frac{3}{16}$ HB	2
26	33-496	Reducer Bushing $\frac{1}{2}$ MPT x $\frac{1}{8}$ FPT	1
27	33-495	Bulkhead Fitting	1
28	14-327	Front Tank Strap	1
29	16-961	Aluminum Adapter 1" Female thread	1
30	16-962	Aluminum Coupler 1" Male Thread	1
	16-962-01	1" Buna-N Gasket (part of 16-962)	1
31	14-365	Air Gap Filler	1
32	16-953	16" Hinged Lid/Well with Gasket (part of tank)	1
	16-953-01	Gasket	1
	16-169	Strainer Basket (not included with tank)	1
33	14-512	Tank Spacer	4
34	16-851	1" Nipple	1
35	18-448	1" Ball Valve	1
36	16-971	45° Elbow	1

* for 15-493 Boom only

NOSE CONE DRAWING

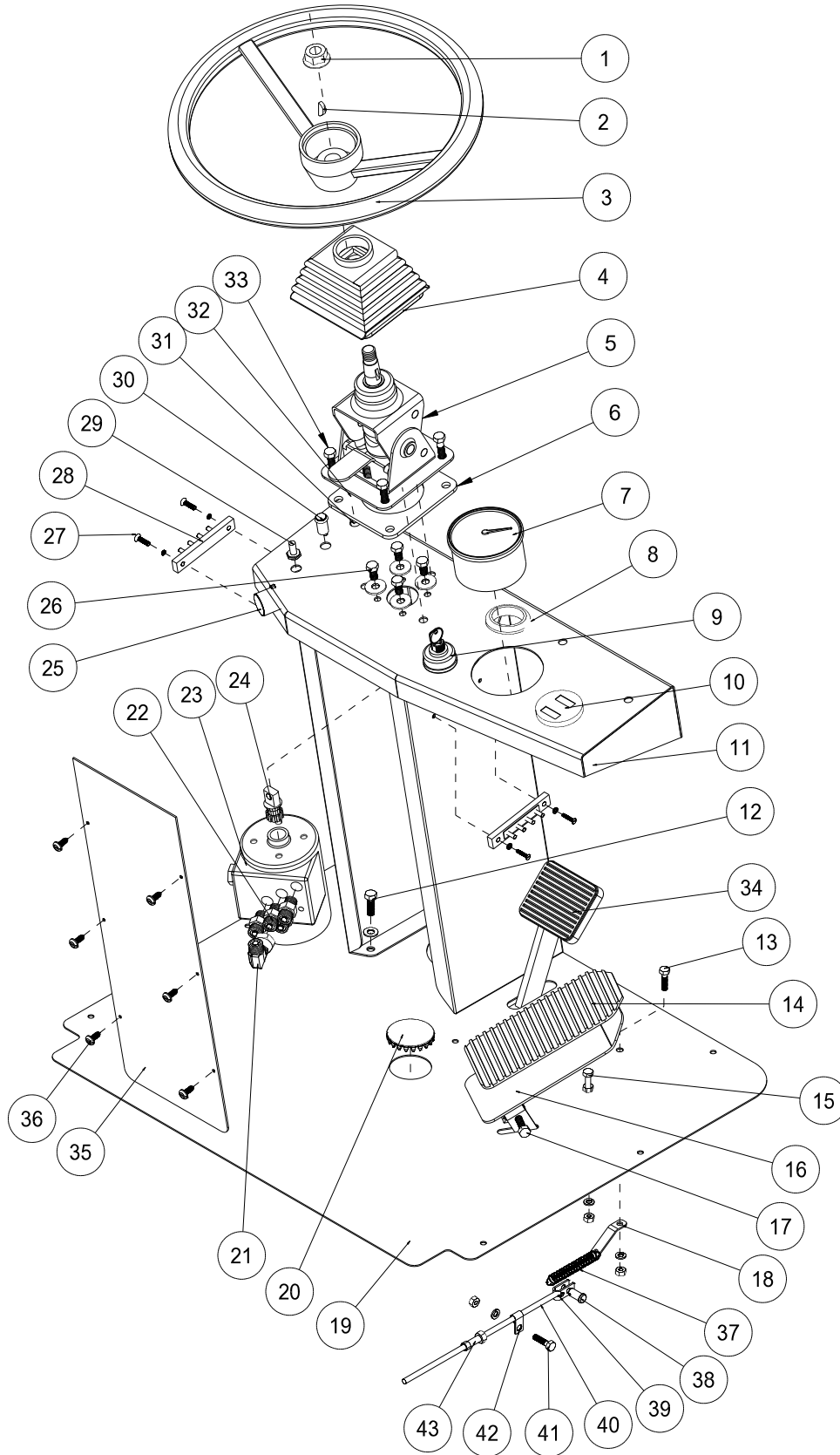

Parts

NOSE CONE PARTSLIST

REF#	PART#	DESCRIPTION	QUANTITY
1	HNJ-58-18	Jam Nut ⁵ / ₈ - 18	1
2	HWK-316-075	Woodruff Key ³ / ₁₆ x ³ / ₄	1
3	13-718	Steering Wheel	1
	13-726	Steering Wheel Cap	
4	76-364	Black Boot	1
5	76-362	Mini Tilt Steering	1
6	15-844	Steering Shim	1
7	14-543	Speedometer (see wiring for terminals)	1
8	50-400	Rubber Grommet	1
9	13-288	Key Switch (Kohler 25 099 04)(part of engine)	1
	76-310	Set of Keys	1
10	12-017	Hour Meter	1
11	14-329	Console	1
	14-346	Decal, Console	1
	8803-8	Black Trim with Lace	2
12	HB-516-18-100	Bolt ⁵ / ₁₆ - 18 x 1	4
	HW-516	Washer ⁵ / ₁₆	4
	HWL-516	Lockwasher ⁵ / ₁₆	4
	HN-516-18	Nut ⁵ / ₁₆ - 18	4
13	HB-14-20-100	Bolt ¹ / ₄ - 20 x 1	1
	HWL-14	Lockwasher ¹ / ₄	1
	HN-14-20	Nut ¹ / ₄ - 20	1
14	13-715	Pedal Pad	1
15	HB-14-20-250	Bolt ¹ / ₄ - 20 x 2 ¹ / ₂	1
	HWL-14	Lockwasher ¹ / ₄	1
	HN-14-20	Nut ¹ / ₄ - 20	2
16	15-336	Foot Pedal	1
17	HB-516-18-100	Bolt ⁵ / ₁₆ -18 x 1	2
	HNTL-516-18	Lock Nut ⁵ / ₁₆ -18	2
18	15-353	Foot Pedal Spring Bracket	1
19	14-328	Floor Board	1
	8803-16	Black Trim	1
20	25-199	2" Plug Button	1
21	18-309	³ / ₈ - 90° Swivel Nut Elbow	1
22	18-306	Straight Thread Connector	4
23	15-301	Orbital	1
24	48-187	Stub Shaft	1
25	77-207	Buzzer (see wiring for terminals)	1
26	HBM-6-1-16	Metric Bolt M6 -1 x 16	4
	HWLM-6	Metric Lockwasher M6	4
27	HSM-10-32-063	Machine Screw #10 - 32 x ⁵ / ₈	4
	HWL-10	Lockwasher #10	4
	HN-10-32	Nut #10 - 32	4
28	8935	Buss Bar	2
29	15-314	Toggle Switch	1
	15-472	Switch Boot	1

(Continued on next page)

NOSE CONE DRAWING

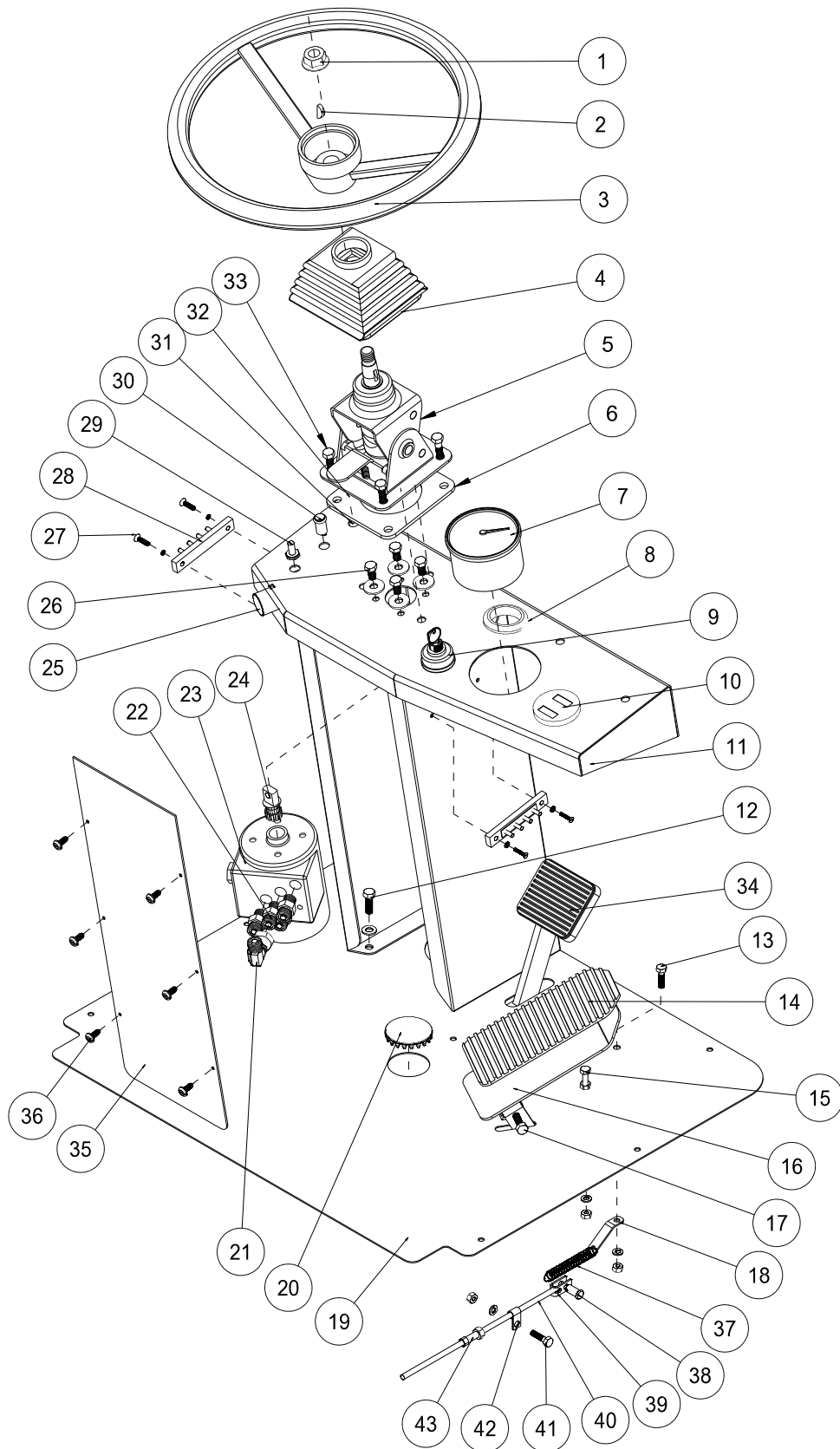

Parts

NOSE CONE PARTSLIST

REF#	PART#	DESCRIPTION	QUANTITY
30	50-359	Warning Light (see wiring for terminals)	1
31	34-146	Circuit Breaker 30 Amp	1
32	34-145	Circuit Breaker Boot	1
33	15-844	Steering Shim	1
	HNTL-516-18	Lock Nut ⁵ / ₁₆ - 18	4
34	15-496	Brake Pedal	1
	16-062	Pedal	1
	15-015	Pedal Pad	1
35	10-200	Tower Plate	1
36	HSA-8-075	Tapping Screw #8 x ³ / ₄	6
37	16-046	Extension Spring	1
38	HCP-14-075	Clevis Pin ¹ / ₄ x ³ / ₄	1
39	17-153	Clevis	1
40	15-310	Throttle Cable	1
41	HB-14-20-100	Bolt ¹ / ₄ - 20 x 1	1
	HWL-14	Lockwasher ¹ / ₄	1
	HN-14-20	Nut ¹ / ₄ - 20	1
42	17-154	Cable Clamp	1
43	17-155	Retainer	1
	HN-516-24	Nut ⁵ / ₁₆ - 24	2

BRAKE DRAWING

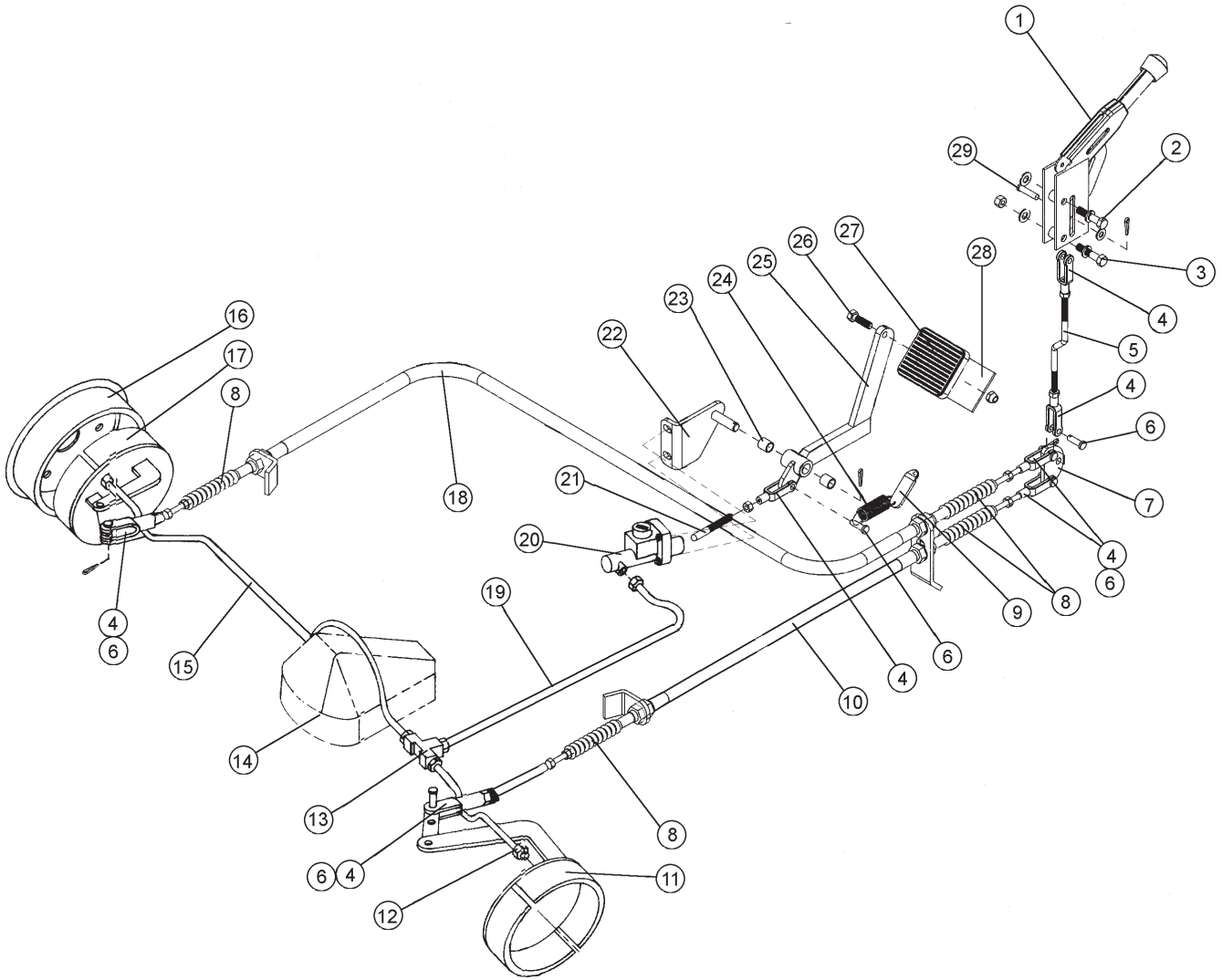

Parts

BRAKE PARTSLIST

REF#	PART#	DESCRIPTION	QUANTITY
1	60-106	Brake Lever	1
2	HB-38-16-175	Bolt $\frac{3}{8}$ - 16 x $1\frac{3}{4}$	1
	HW-38	Washer $\frac{3}{8}$	1
	HWL-38	Lockwasher $\frac{3}{8}$	1
3	HB-38-16-175	Bolt $\frac{3}{8}$ - 16 x $1\frac{3}{4}$	1
	HW-38	Washer $\frac{3}{8}$	1
	HWL-38	Lockwasher $\frac{3}{8}$	1
	HN-38-16	Nut $\frac{3}{8}$ - 16	1
4	11-100	Yoke	7
	HN-516-24	Nut $\frac{5}{16}$ - 24	7
5	15-347	Brake Rod	1
6	HCP-516-100	Clevis Pin $\frac{5}{16}$ x 1	6
	HP-18-100	Cotter Pin $\frac{1}{8}$ x 1	6
7	15-331	Park Brake relay	1
8	60-536	Bellows	4
9	15-354	Brake Pedal Spring Bracket	1
10	14-338	Right Brake Cable	1
11	16-554	Right Brake Assembly (comes with 16-037)	1
12	16-187	Brake Line $\frac{3}{16}$ x 12 (steel)	1
13	18-089	Tee	1
14	16-037	Rear Axle	1
15	16-188	Brake Line $\frac{3}{16}$ x 34 (steel)	1
16	16-559	Brake Drum (comes with 16-037)	2
17	16-514	Left Brake Assembly (comes with 16-037)	1
18	14-339	Left Brake Cable	1
19	15-312	Brake Line $\frac{3}{16}$ x 84	1
20	50-123	Brake Cylinder	1
	50-123-01	Cap Master Cylinder	1
	50-123-02	Brake Master Cylinder Kit	1
	HB-38-16-125	Bolt $\frac{3}{8}$ - 16 x $1\frac{1}{4}$	2
	HNTL-38-16	Lock Nut $\frac{3}{8}$ - 16	2
21	10-126	Brake Rod	1
22	15-497	Brake Bracket	1
	HB-38-16-150	Bolt $\frac{3}{8}$ - 16 x $1\frac{1}{2}$	2
	HNTL-38-16	Lock Nut $\frac{3}{8}$ - 16	2
	HP-18-100	Cotter Pin $\frac{1}{8}$ x 1	1
23	20-019	Bushing (comes with 15-496)	2
24	11-050	Extension Spring	1
25	15-496	Brake Pedal	1
26	HB-38-16-100	Bolt $\frac{3}{8}$ - 16 x 1	1
	HNTL-38-16	Lock Nut $\frac{3}{8}$ - 16	1
27	15-015	Pedal Pad	1
28	16-062	Pedal	1
29	HCP-516-125	Clevis Pin $\frac{5}{16}$ x $1\frac{1}{4}$ (comes 60-106)	1
	HP-18-100	Cotter Pin $\frac{1}{8}$ x 1	1
	HW-516	Washer $\frac{5}{16}$	1

PUMPS AND EXHAUST DRAWING

Parts

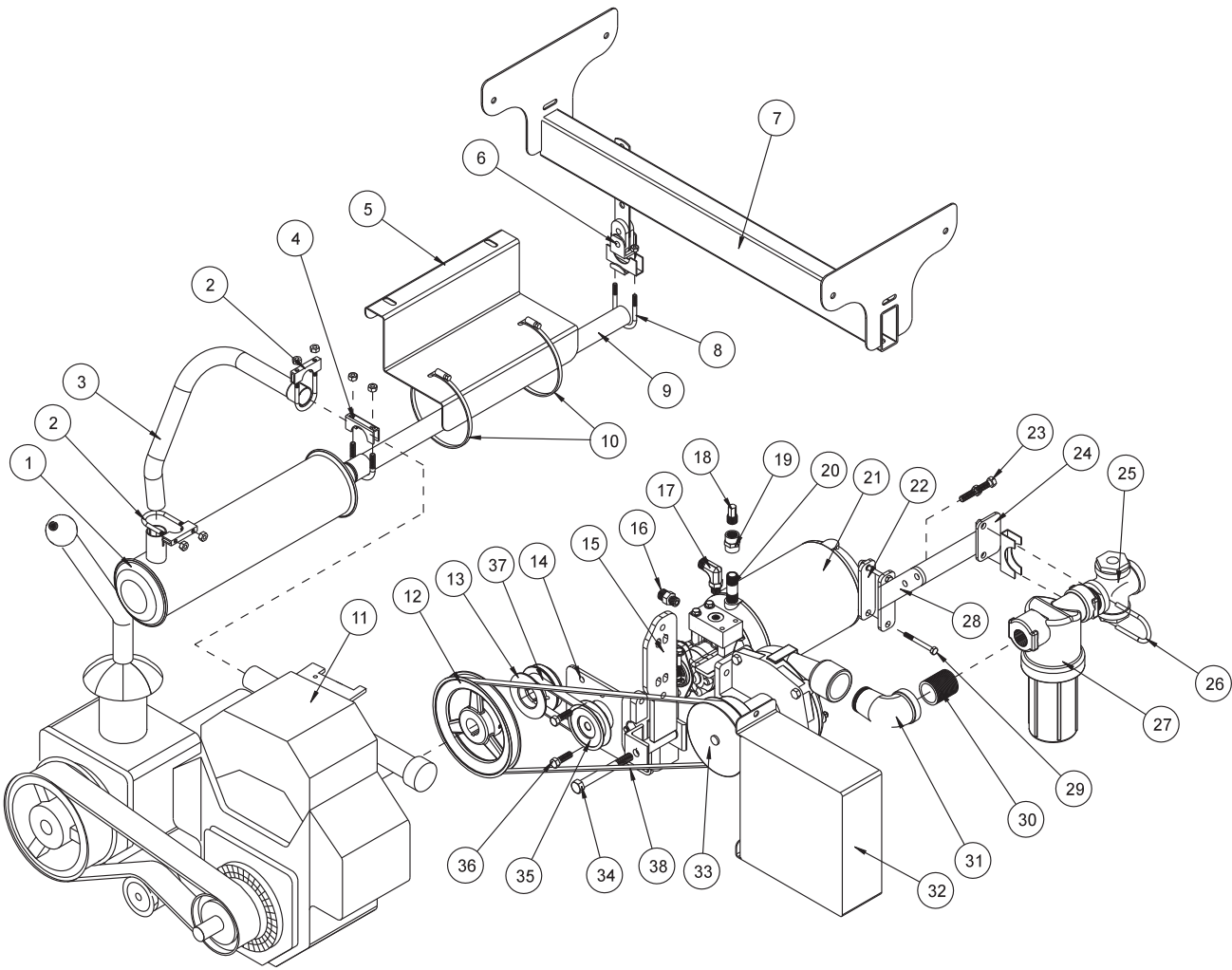

PUMPS AND EXHAUST PARTS LIST

REF#	PART#	DESCRIPTION	QUANTITY
1	15-371	Muffler	1
2	13-498	Muffler Clamp 1 ¹ / ₈	2
3	15-379	Exhaust Pipe	1
4	18-220	Muffler Clamp 1 ¹ / ₄	1
5	15-386	Muffler Bracket	1
6	33-159	Universal Exhaust Hanger	1
	HSDPS-14-100	Pan Head Drill Screw SS 1/4 x 1	1
7	14-321	Tank Carrier	1
8	50-111	Muffler Clamp 1 ¹ / ₂	1
9	15-387	Tail Pipe	1
10	18-147	Hose Clamps	2
11	15-373	Engine Kohler Command 20 hp	1
	15-373-01	Exhaust Manifold (Kohler 24 164 11)	1
12	15-316	Pulley BH72 x 1 ¹ / ₈	1
	HSSHS-516-50	Socket Head Set Screw 5/16 x 1/2	2
	HKSQ-14-150	Machine Key 1/4 x 1/4 x 1 ¹ / ₂	1
13	15-318	Pulley with Hub BK30H 1 ¹ / ₈	1
	HKSQ-14-150	Machine Key 1/4 x 1/4 x 1 ¹ / ₂	1
	HB-14-20-075	Bolt 1/4 - 20 x 3/4	2
14	15-344	Pump Mount Plate	1
	HBCL-38-16-100	Low Carriage Bolt 3/8 - 16 x 1	2
	HNTL-38-16	Lock Nut 3/8 - 16	2
15	15-580	Pump Arm	1
16	18-306	1 ¹ / ₁₆ x 9/16 Straight Thread Connector	1
17	18-171	1 ¹ / ₁₆ x 9/16 90° Straight Thread Elbow	1
18	27-059	Filler Breather (part of 15-315)	1
19	18-314	3/8 Coupler	1
20	18-287	3/8 Pipe Nipple x 2	1
21	15-315	Hydraulic Power Unit	1
	15-315-01	Repair Kit	1
	HWK-18-063	Woodruff Key 1/8 x 5/8	1
22	15-465	Rear Mount Plate	1
23	HB-38-16-125	Bolt 3/8 - 16 x 1 ¹ / ₄	2
	HW-38	Washer 3/8	2
	HNTL-38-16	Lock Nut 3/8 - 16	2
24	15-521	Top Filter Bracket	1
25	16-976	Cross 1 ¹ / ₄	1
26	50-394	Muffler Clamp	1
27	14-521	Strainer	1
28	15-522	Bottom Filter Bracket	1
29	HB-38-16-250	Bolt 3/8 - 16 x 2 ¹ / ₂	2
	HNTL-38-16	Lock Nut 3/8 - 16	2
30	16-880	Close Nipple 1 ¹ / ₄	1
31	16-972	Elbow 1 ¹ / ₄	1
32	15-345	Belt Guard	1
33	16-998	Hypro® Pump	1
34	HB-12-13-450	Bolt 1/2 - 13 x 4 ¹ / ₂	1
	HNCL-12-13	Center Lock Nut 1/2 - 13	1
	HMB-12-14	Machine Bushing 1/2 x 14GA	6
35	15-414	Pulley BK30 x 1/2	1
36	HB-38-16-125	Bolt 3/8 - 16 x 1 ¹ / ₄	2
	HNTL-38-16	Lock Nut 3/8 - 16	2
37	15-320	Belt 5L230	1
38	16-869	Belt L447	1

SPRAY PUMP DRAWING

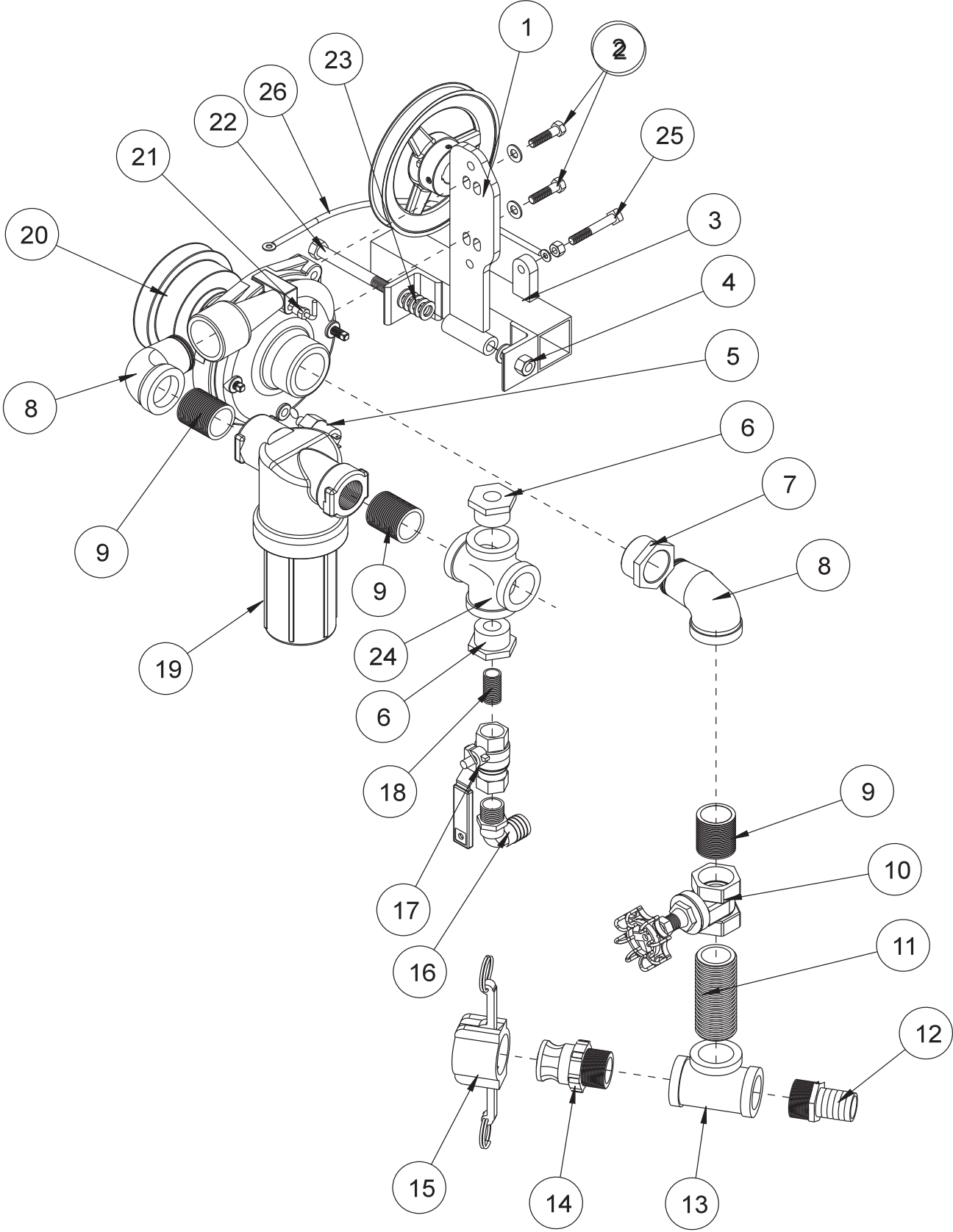

Parts

SPRAY PUMP PARTS LIST

REF#	PART#	DESCRIPTION	QUANTITY
1	15-580	Pump Arm	1
2	HB-38-16-150	Bolt $\frac{3}{8}$ - 16 x $1\frac{1}{2}$	2
	HW-38	Washer $\frac{3}{8}$	2
	HNTL-38-16	Lock Nut $\frac{3}{8}$ - 16	2
3	14-353	Main Frame	1
4	HNCL-12-13	Center Lock Nut $\frac{1}{2}$ - 13	1
5	33-480	Pressure Switch	1
6	18-388	Bushing $1\frac{1}{4}$ x $\frac{3}{4}$	2
7	16-825	Reducer Bushing $1\frac{1}{2}$ x $1\frac{1}{4}$	1
8	16-972	Elbow $1\frac{1}{4}$	2
9	16-880	Close Nipple $1\frac{1}{4}$	3
10	16-170	Gate Valve $1\frac{1}{4}$	1
11	18-389	Nipple $1\frac{1}{4}$ x 4	1
12	16-161	Fitting $1\frac{1}{4}$ MPT x $1\frac{1}{4}$ HB	1
13	18-390	Tee $1\frac{1}{4}$	1
14	16-180	Quick Coupler $1\frac{1}{4}$ Male	1
15	16-935	Quick Coupler Cap	1
16	16-155	Elbow $\frac{3}{4}$ MPT x 1HB	1
17	16-859	Ball Valve $\frac{3}{4}$	1
18	16-158	Close Nipple $\frac{3}{4}$	1
19	14-521	Strainer	1
20	16-998	Hypro® Pump	1
	8859	Male Slide on Terminal	1
	8962	Heat Shrink $\frac{3}{16}$ X $1\frac{1}{4}$	1
21	33-494	Elbow $\frac{1}{8}$ MPT x $\frac{3}{16}$ HB	1
22	HB-12-13-450	Bolt $\frac{1}{2}$ - 13 x $4\frac{1}{2}$	1
23	HMB-12-14	Machine Bushing $\frac{1}{2}$ x 14GA	6
24	16-976	Cross $1\frac{1}{4}$	1
25	HSSQ-38-16-250	Square Head Set Screw $\frac{3}{8}$ - 16 x $2\frac{1}{2}$	1
	HN-38-16	Nut $\frac{3}{8}$ - 16	1
26	15-457	Ground Wire	1



FRONT AXLE DRAWING

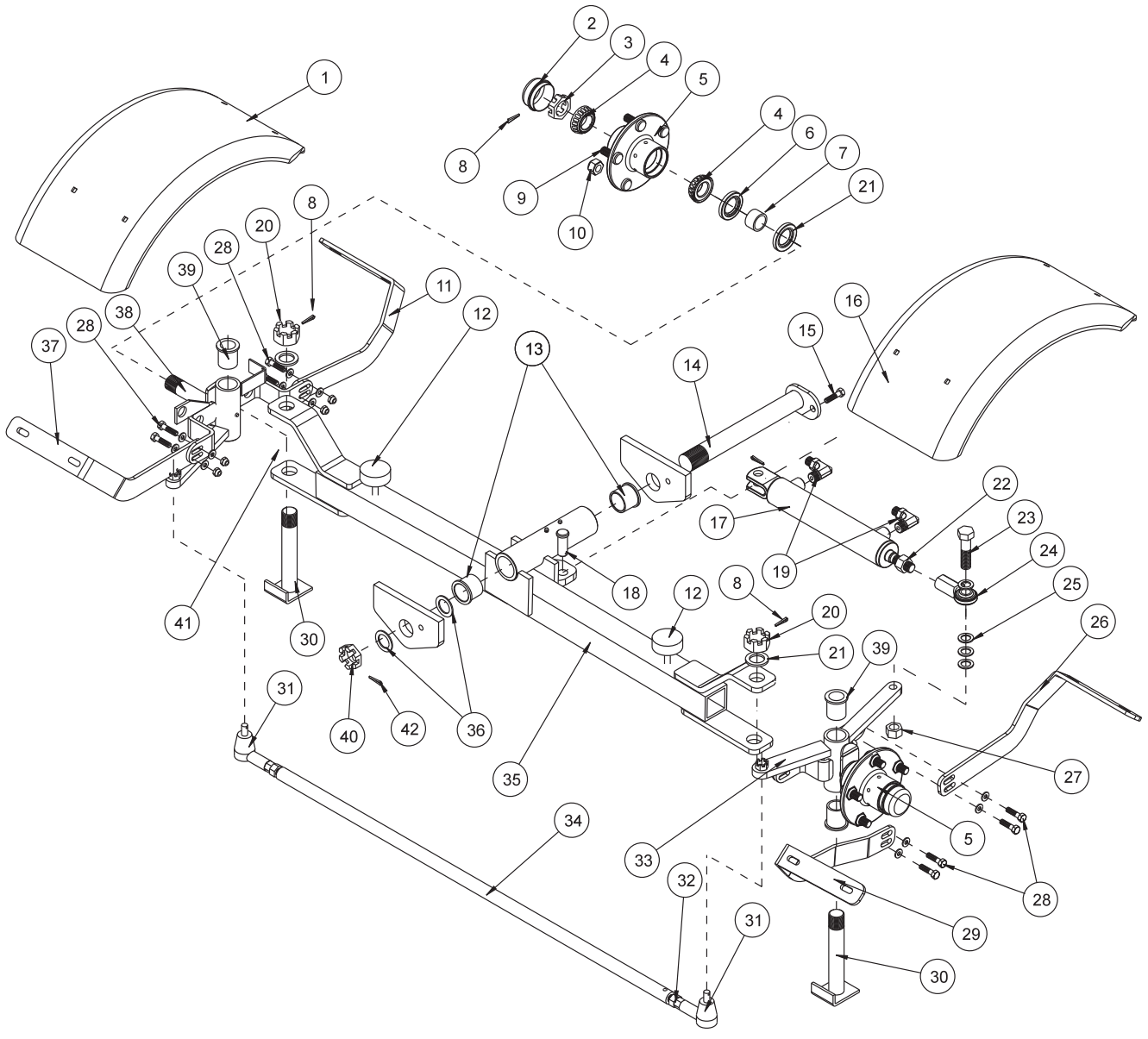

Parts

FRONT AXLE PARTSLIST

REF#	PART#	DESCRIPTION	QUANTITY
1	10-180	Left Front Fender	1
	HBC-516-18-100	Carriage Bolt ⁵ / ₁₆ - 18 x 1	4
	HW-516	Washer ⁵ / ₁₆	4
	HWL-516	Lock Washer ⁵ / ₁₆	4
	HN-516-18	Nut ⁵ / ₁₆ - 18	4
2*	80-167	Dust Cap	2
3	HNAR-100-14	Slotted Jam Nut 1 - 14	2
4*	11-043	Bearing	4
5	80-019	Hub (includes * items)	2
6*	11-041	Oil Seal	2
7	11-042	Spacer	2
8	HP-18-150	Cotter Pin ¹ / ₈ x 1 ¹ / ₂	4
9*	27-022-02	Stud ¹ / ₂ - 20	10
10*	HNL-12-20	Lug Nut ¹ / ₂ - 20	10
11	14-368	Left Front Fender Bracket - Front	1
12	50-081	Rubber Bumper	2
13	18-153	Bushing (part of 14-457)	2
14	14-344	Axle Pin	1
15	HB-516-18-125	Bolt ⁵ / ₁₆ - 18 x 1 ¹ / ₄	1
	HNTL-516-18	Lock Nut ⁵ / ₁₆ - 18	1
16	10-180	Right Front Fender	1
	HBC-516-18-100	Carriage Bolt ⁵ / ₁₆ - 18 x 1	4
	HW-516	Washer ⁵ / ₁₆	4
	HWL-516	Lockwasher ⁵ / ₁₆	4
	HN-516-18	Nut ⁵ / ₁₆ - 18	4
17	77-263	Hydraulic Cylinder	1
	14-530	Seal Kit	1
18	HCP-58-150	Clevis Pin ⁵ / ₈ x 1 ¹ / ₂	1
	HP-18-100	Cotter Pin ¹ / ₈ x 1	1
19	18-171	¹¹ / ₁₆ x ⁹ / ₁₆ 90° Straight Thread Elbow	2
20	HNA-100-14	Slotted Axle Nut 1 - 14	2
21	HMB-100-10	Machine Bushing 1 x 10GA	4
22	HNJ-58-18	Jam Nut ⁵ / ₈ - 18	1
23	HB-58-11-250	Bolt ⁵ / ₈ - 11 x 2 ¹ / ₂	1
24	18-154	Rod End	1
25	HMB-58-14	Machine Bushing ⁵ / ₈ - 14	6
26	14-367	Right Front Fender Bracket - Front	1
27	HNTL-58-11	Lock Nut ⁵ / ₈ - 11	1
28	HB-516-18-125	Bolt ⁵ / ₁₆ - 18 x 1 ¹ / ₄	8
	HW-14	Washer ¹ / ₄	16
	HNTL-516-18	Lock Nut ⁵ / ₁₆ - 18	8
29	14-356	Right Front Fender Bracket - Rear	1
30	16-076	King Pin	2
31	16-565	Rod End	2
32	HNM-12-125	Metric Nut M12 x 1.25	2
33	10-295	Right Spindle	1
	HG-14-28-180	Grease Fitting ¹ / ₄ - 28 x 180°	1
34	14-345	Tie Rod	1
35	14-457	Front Axle	1
	HG-14-28-180	Grease Fitting ¹ / ₄ - 28 x 180°	1
36	HMB-114-10	Machine Bushing 1 ¹ / ₄ x 10GA	2
37	14-357	Left Front Fender Bracket - Rear	1
38	10-294	Left Spindle	1
	HG-14-28-180	Grease Fitting ¹ / ₄ - 28 x 180°	1
39	33-086	Bushing (part of 10-294 & 10-295)	4
40	HNAT-114-12	Axle Nut 1 ¹ / ₄ - 12	1
41	HMB-100-14	Machine Bushing 1 x 14GA	4
42	HP-18-200	Cotter Pin ¹ / ₈ x 2	1

CLUTCH LINKAGE DRAWING

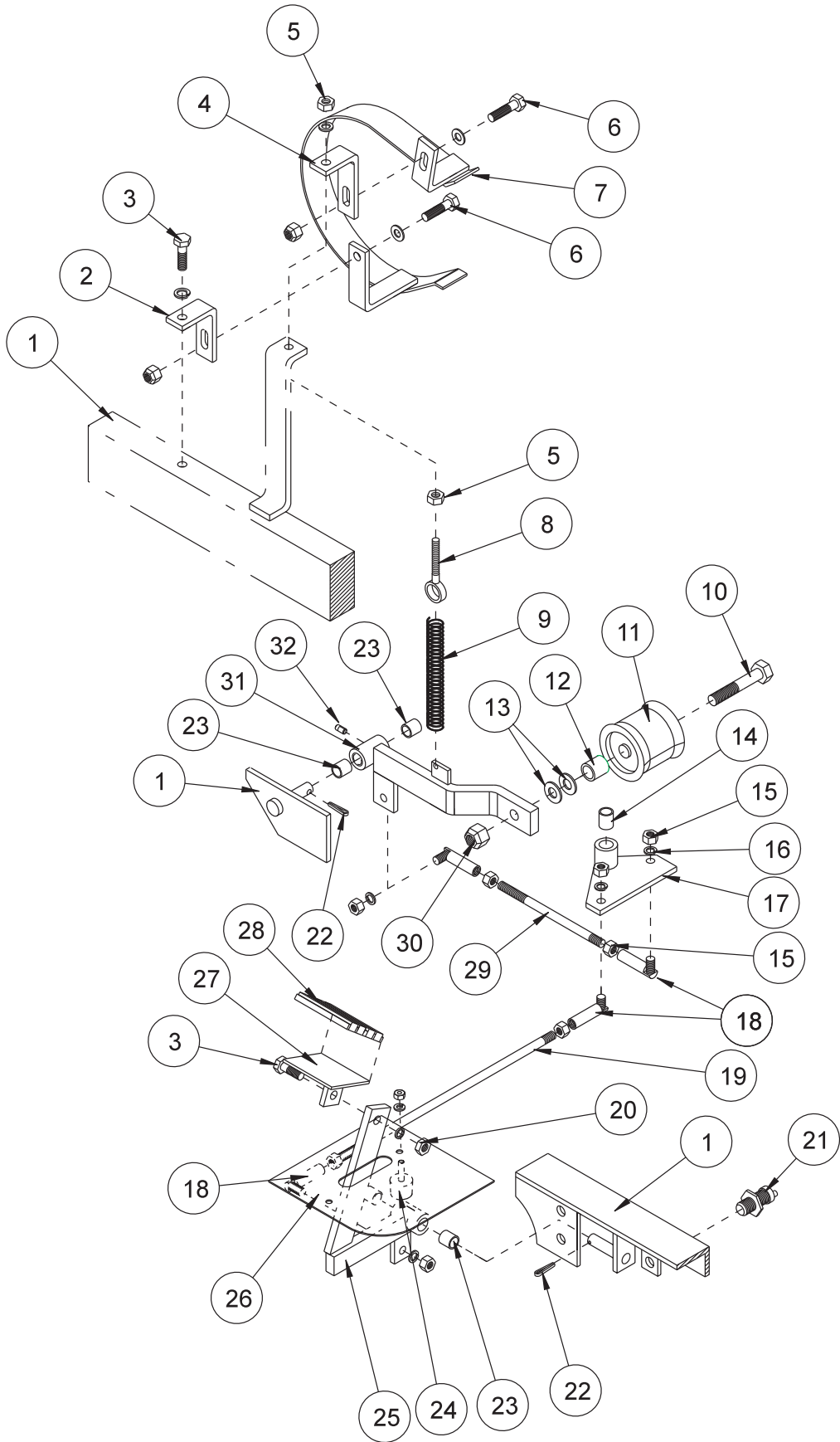

Parts

CLUTCH LINKAGE PARTS LIST

REF#	PART#	DESCRIPTION	QUANTITY
1		Part of Main Frame	
2	15-482	Bottom Mount Bracket	1
3	HB-38-16-100	Bolt $\frac{3}{8}$ - 16 x 1	2
	HWL-38	Lockwasher $\frac{3}{8}$	2
4	15-483	Top Mount Bracket	1
5	HN-516-18	Nut $\frac{5}{16}$ - 18	2
	HW-516	Washer $\frac{5}{16}$	1
6	HB-38-16-125	Bolt $\frac{3}{8}$ - 16 x $1\frac{1}{4}$	2
	HW-38	Washer $\frac{3}{8}$	2
	HNTL-38-16	Lock Nut $\frac{3}{8}$ - 16	2
7	15-481	Belt Guard	1
8	20-008	Eye Bolt $\frac{5}{16}$ - 18	1
9	16-830	Spring	1
10	HB-12-13-300	Bolt $\frac{1}{2}$ - 13 x 3	1
11	16-013	Idler Pulley	1
12	15-376	Clutch Arm Spacer	1
13	HMB-12-14	Machine Bushing $\frac{1}{2}$ x 14GA	As Required
14	10-007	Oilite Bushing (part of 15-337)	1
15	HN-38-24	Nut $\frac{3}{8}$ - 24	8
16	HWL-38	Lockwasher $\frac{3}{8}$	4
17	15-337	Clutch Relay	1
	HB-12-13-275	Bolt $\frac{1}{2}$ - 13 x $2\frac{3}{4}$	1
	HNTL-12-13	Lock Nut $\frac{1}{2}$ - 13	1
18	21-173	Ball Joint $\frac{3}{8}$ - 24	4
19	15-348	Long Clutch Rod	1
20	HN-38-16	Nut $\frac{3}{8}$ - 16	1
21	22-002	Interlock Switch	1
22	HP-18-100	Cotter Pin $\frac{1}{8}$ x 1	2
23	20-019	Bushing (part of 15-360 & 15-341)	4
24	15-013	Rubber Bumper	1
	HWL-14	Lockwasher $\frac{1}{4}$	1
	HN-14-20	Nut $\frac{1}{4}$ - 20	1
25	15-360	Clutch Pedal	1
26	14-328	Floor Board	1
27	16-062	Pedal	1
28	15-015	Pedal Pad	1
29	15-349	Short Clutch Rod	1
30	HNTL-12-13	Lock Nut $\frac{1}{2}$ - 13	1
31	15-341	Clutch Arm	1
32	HG-14-28-180	Grease Fitting $\frac{1}{4}$ - 28 x 180°	1

ENGINE AND CONTROL PANEL DRAWING

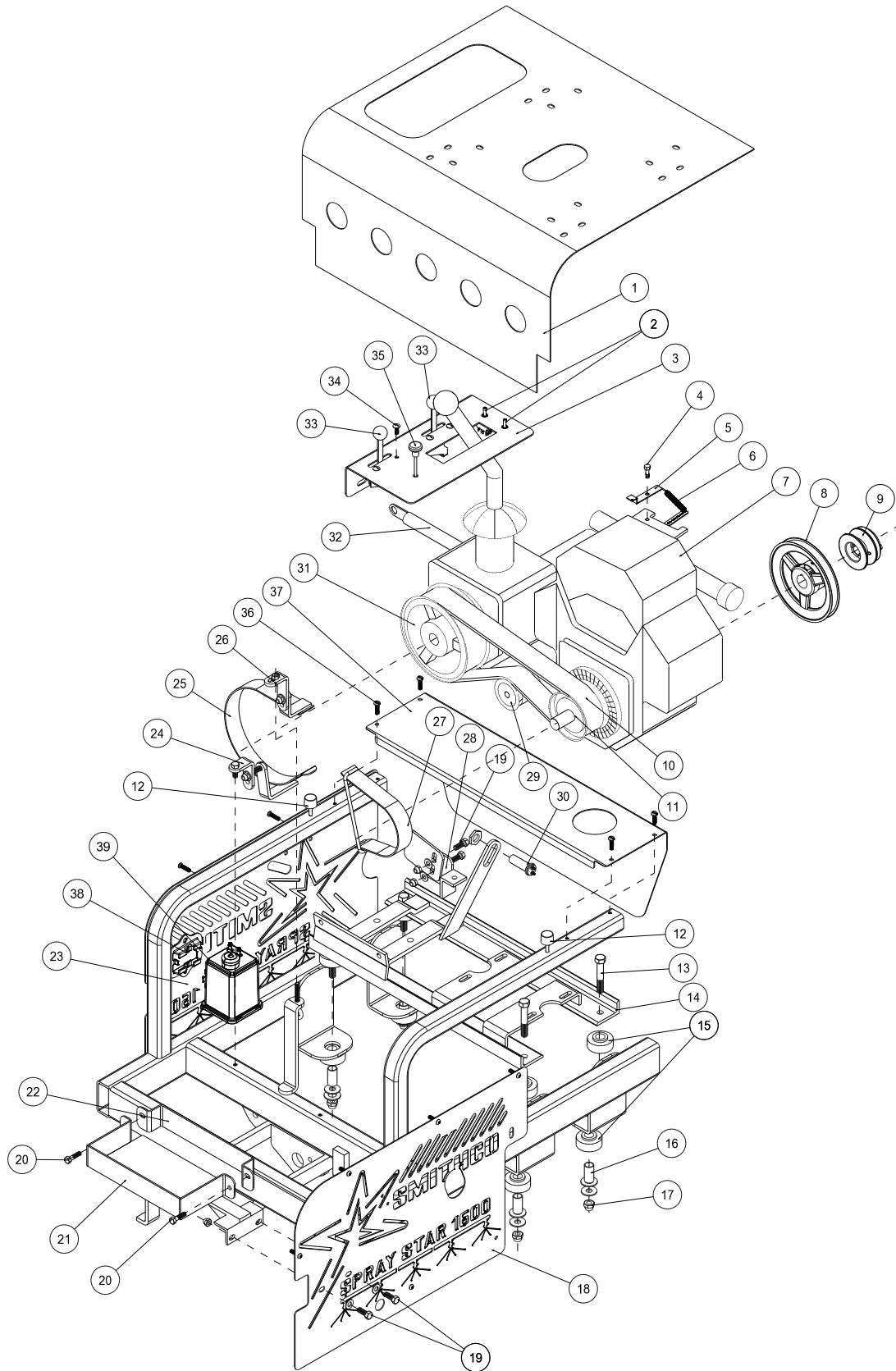

Parts

ENGINE AND CONTROL PANEL PARTS LIST

REF#	PART#	DESCRIPTION	QUANTITY
1	15-356	Engine/Seat Cover	1
	8803-41	Trim	1
2	16-755	Boom Control Switch	2
	15-472	Switch Boot	2
3	14-295	Control Panel	1
	14-296	Decal, Control Panel	1
4	HB-14-20-075	Bolt $\frac{1}{4}$ - 20 x $\frac{3}{4}$	1
	HW-14	Washer $\frac{1}{4}$	1
	HNTL-14-20	Lock Nut $\frac{1}{4}$ - 20	1
5	15-335	Governor Linkage Arm	1
6	16-046	Extension Spring	1
7	15-373	Kohler 20 hp Command Engine	1
	8800-9	Fuel Hose	1
	18-186	Hose Clamp	2
	50-403	Fuel Filter	1
	HB-38-16-175	Bolt $\frac{3}{8}$ - 16 x $1\frac{3}{4}$	4
	HW-38	Washer $\frac{3}{8}$	4
	HNTL-38-16	Lock Nut $\frac{3}{8}$ - 16	4
	15-316	Pulley BK72 x $1\frac{1}{8}$	1
	HKSQ-14-150	Machine Key $\frac{1}{4}$ x $\frac{1}{4}$ x $1\frac{1}{2}$	1
	15-318	Pulley BK30H with Hub $1\frac{1}{8}$	1
9	HKSQ-14-150	Machine Key $\frac{1}{4}$ x $\frac{1}{4}$ x $1\frac{1}{2}$	1
	16-827	Belt	1
11	16-820	Pulley $4\frac{1}{4}$ OD with Hub	1
	HKSQ-14-150	Machine Key $\frac{1}{4}$ x $\frac{1}{4}$ x $1\frac{1}{2}$	1
12	15-013	Rubber Bumper	2
13	HB-12-13-300	Bolt $\frac{1}{2}$ - 13 x 3	4
14	15-357	Engine Frame	1
15	60-107	Rubber Bushing	8
16	60-168	Spacer	4
	HNFL-12-13	Flange Whiz Lock Nut $\frac{1}{2}$ - 13	4
	HW-58	Washer $\frac{5}{8}$	4
18	HW-716	Washer $\frac{7}{16}$	4
	14-349	Left Side Panel	1
	HSDPS-14-100	Pan Head Drill Screw SS $\frac{1}{4}$ x 1	5
19	HB-38-16-100	Bolt $\frac{3}{8}$ - 16 x 1	4
	HW-38	Washer $\frac{3}{8}$	8
	HNTL-38-16	Lock Nut $\frac{3}{8}$ - 16	4
20	HB-516-18-125	Bolt $\frac{5}{16}$ - 18 x $1\frac{1}{4}$	2
	HWL-516	Lockwasher $\frac{5}{16}$	2
	HN-516-18	Nut $\frac{5}{16}$ - 18	2
21	15-330	Battery Box	1
	33-216	Battery	1
	22-054	Black Battery Cable	1
22	15-388	Battery Box Front	1
23	14-350	Right Side Panel	1
	HSDPS-14-100	Pan Head Drill Screw SS $\frac{1}{4}$ x 1	6
24	15-482	Bottom Mount Bracket	1

(Continued on next page)

ENGINE AND CONTROL PANEL DRAWING

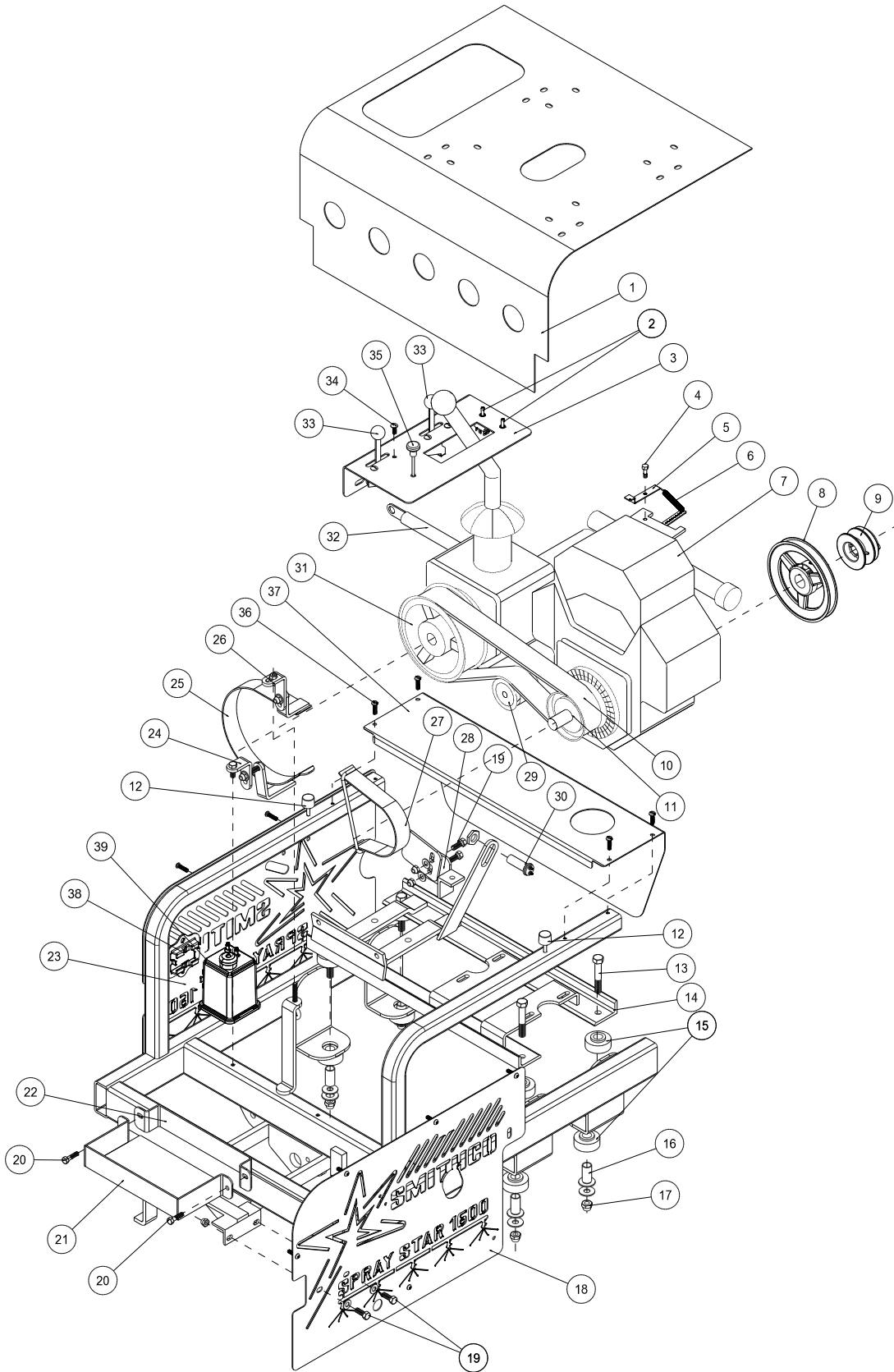

Parts

ENGINE AND CONTROL PANEL PARTS LIST

REF#	PART#	DESCRIPTION	QUANTITY
25	15-481	Belt Guard	1
26	15-483	Top Mounting Bracket	1
27	15-555	Left Belt Guard	1
28	15-556	Guard Mount	1
29	16-013	Idler Pulley	1
30	16-883	Magnetic Sensor	1
31	16-821	Pulley 7 ¹ / ₂ OD with Hub	1
	HWK-14-1125	Woodruff Key 1/4 x 1 ¹ / ₈	1
32	50-323	Red Battery Cable	1
33	14-297	Throttle Cable	2
	42-766	Cable Mount	2
34	HSTP-14-20-075	Phillips Truss Head Machine Screw 1/4 - 20 x 3/4	4
	HW-14	Washer 1/4	4
	HWL-14	Lockwasher 1/4	4
	HN-14-20	Nut 1/4 - 20	4
35	11-086	Choke Cable	1
36	HSDPS-14-100	Pan Head Drill Screw SS 1/4 x 1	4
37	14-326	Rear Engine Cover	1
38	8-688	Mount Bracket	1
39	8-689	Carbon Canister	1
	8-693	Hose Connector	1
	8800-26	Hose (to engine)	1
	8800-43	Hose (to gas tank)	1
	18-186	Hose Clamp	2
NS	17-154	Cable Clamp	1
NS	21-161	Wire Block	4

GAS TANK DRAWING

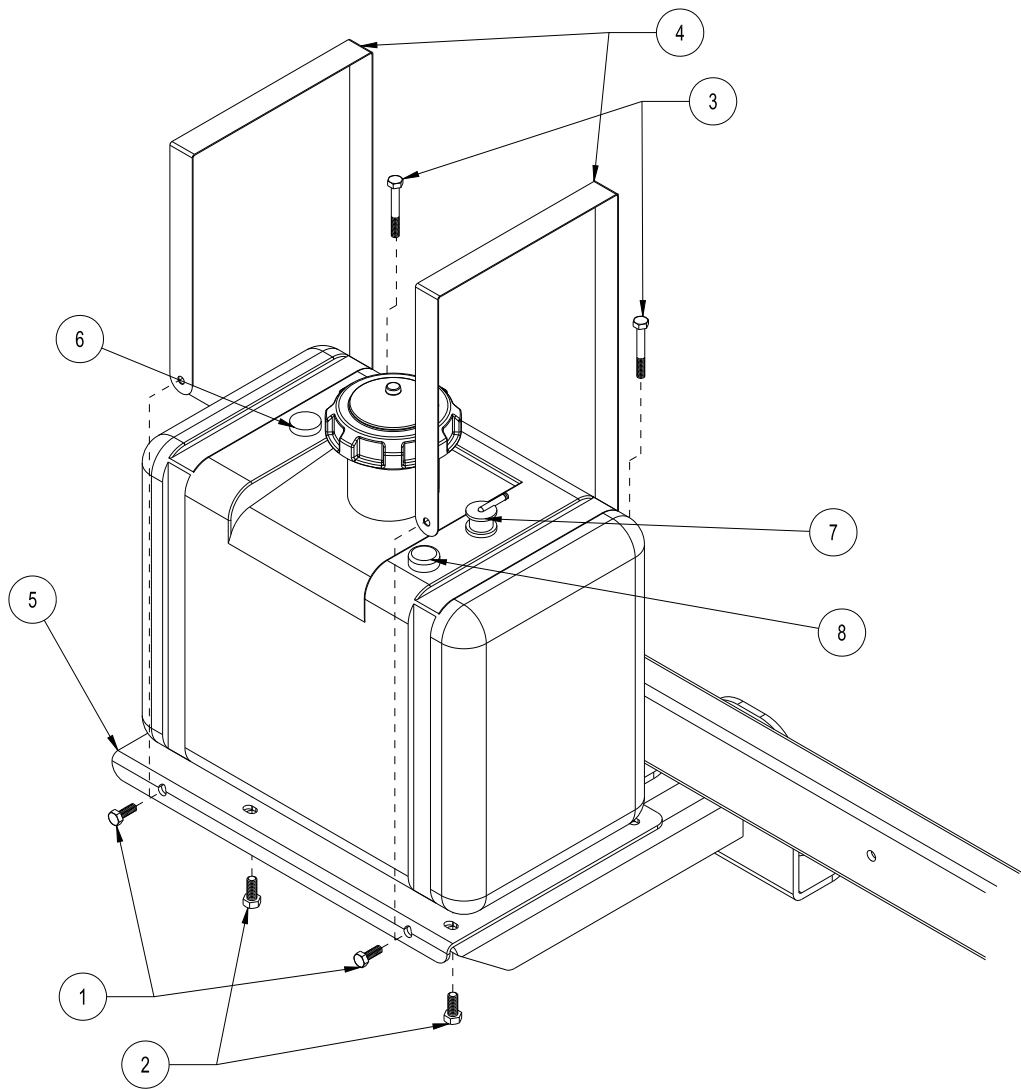

Parts

GAS TANK PARTSLIST

REF#	PART#	DESCRIPTION	QUANTITY
1	HB-14-20-075	Bolt	2
	HNTL-14-20	Lock Nut	2
2	HSTP-516-18-075	Machine Screw	4
	HNFL-516-18	Flange Lock Nut	4
3	HB-14-20-200	Bolt	2
	HNTL-14-20	Lock Nut	2
4	78-456	Tank Strap	2
5	14-533	Gas Tank Bracket	1
6	15--838	6 Gallon CARB Gas Tank (includes all * items)	1
	*	Neck Vent Port	1
	8800-43	Fuel Hose 1/4" x 43(tank to carb canister)	1
	18-186	Hose Clamp	2
7	*	Top Draw	1
	8800-31	Fuel Hose 1/4" x 31	1
	18-186	Hose Clamp	2
8	*	Dial Fuel Level Gage	1

TURBOQUAD AGITATOR DRAWING

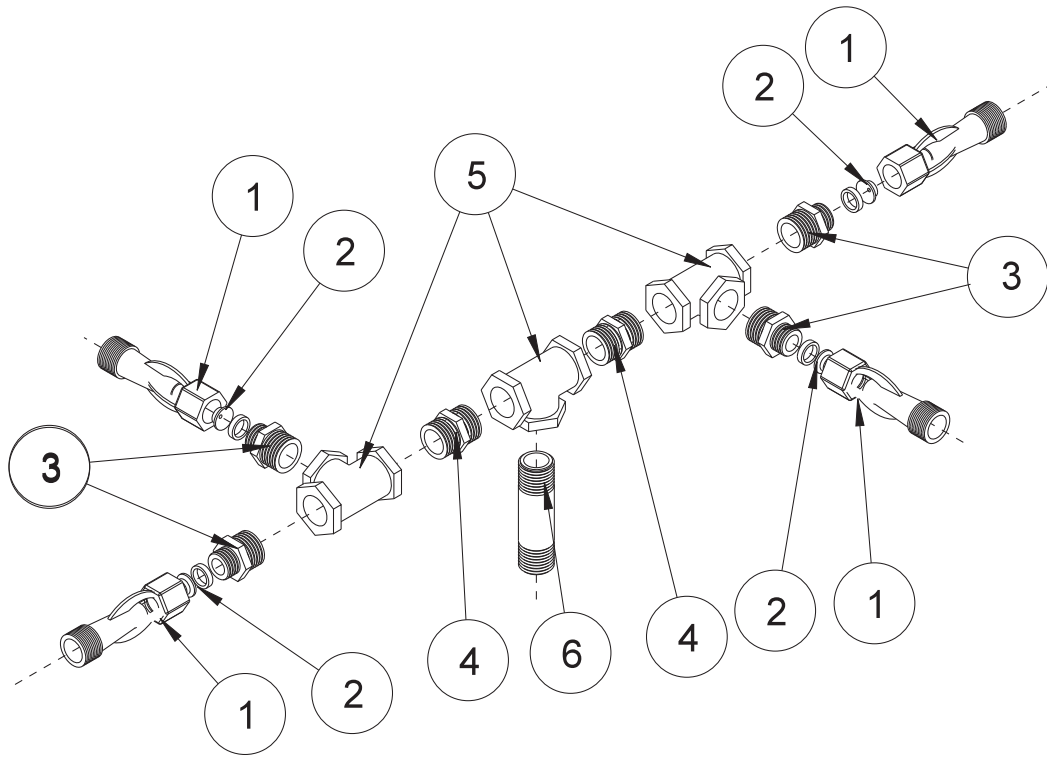

14-521 STRAINER DRAWING

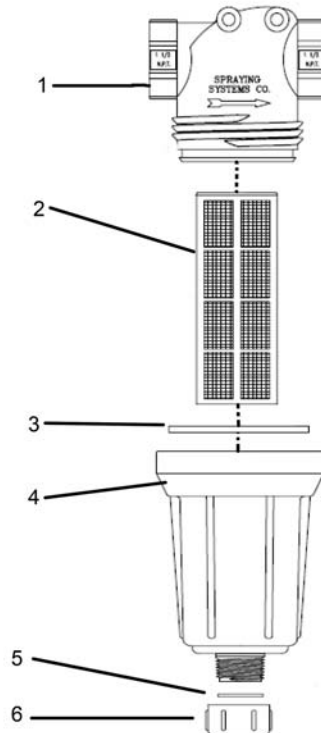

TURBO QUAD AGITATOR PARTS LIST

REF#	PART#	DESCRIPTION	QUANTITY
1	16-036	Agitator Jets (includes one each 1/8", 5/32", and 3/16" orifices)	4
2		Interchangeable Nozzles 3/16" (factory installed)	4
3	16-173	Reducer 3/4 x 1/2	4
4	16-158	Close Nipple 3/4	2
5	16-157	Tee Female Pipe Thread 3/4 x 3/4 x 3/4	3
6	16-172	Nylon Nipple 3/4 NPT x 3 1/2	1
	*	One each comes with 16-036 Agitator Jet.	

14-521 STRAINER PARTS LIST

REF#	PART#	DESCRIPTION	QUANTITY
1	14-521-01	Head 1 1/4 (Poly)	1
2	16-968-03	Screen	1
3	14-521-02	Gasket	1
4	14-521-03	Bowl	1
5	14-521-04	Gasket	1
6	14-521-05	Cap	1

15-301 ORBITOR DRAWING

Parts

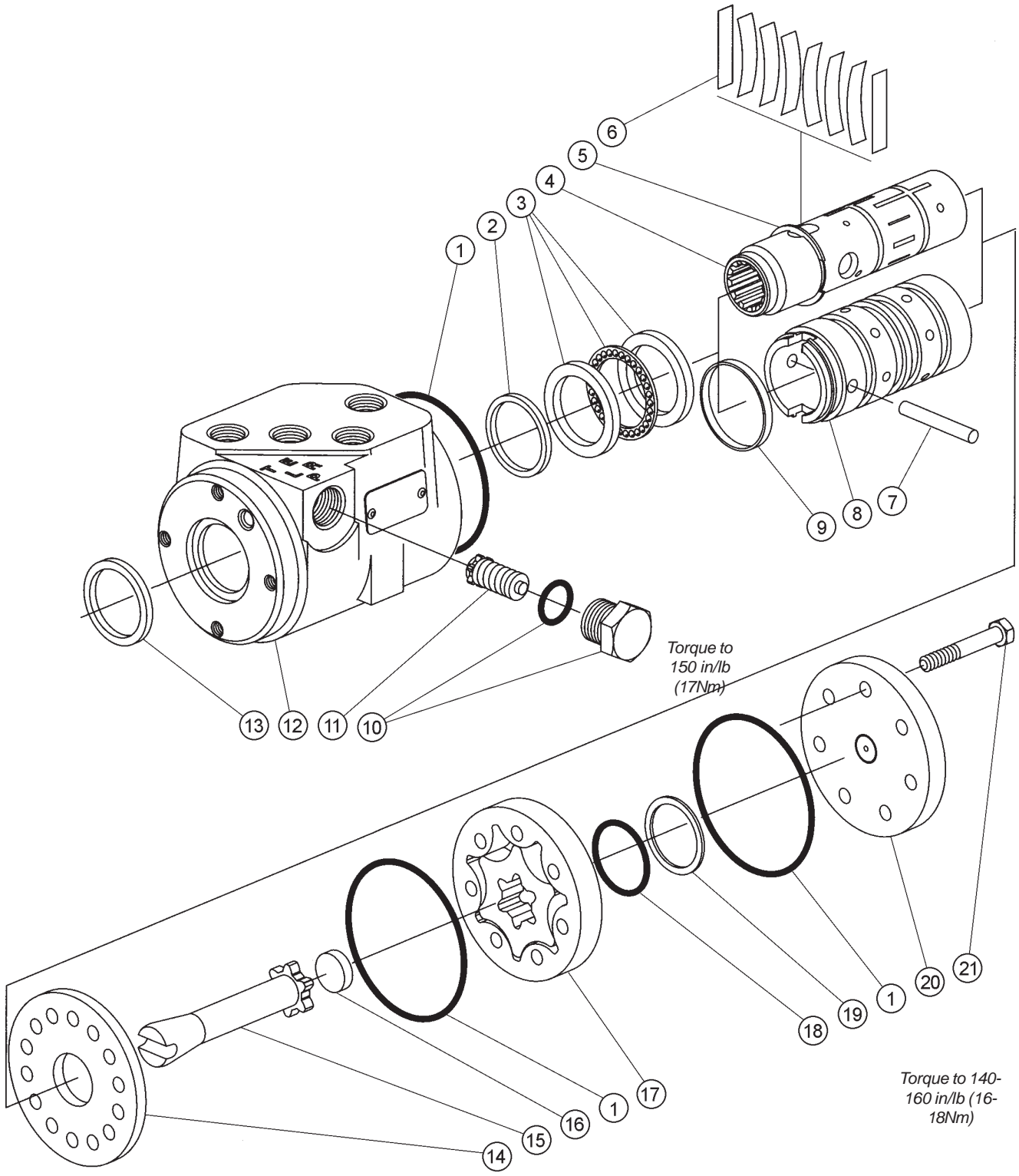

15-301 ORBITOR PARTS LIST

REF#	PART#	DESCRIPTION	QUANTITY
1*		O-Ring Seal	3
2*		Quad Seal	1
3	15-301-14	Bearing Kit	1
		Bearing Race	2
		Bearing	1
4		Spool	1
5	15-301-13	External Retaining Ring	1
6	15-301-15	Spring Centering Kit (Includes Ref# 9)	1
		Spring Spacer	2
		Centering Spring	6
		Spring Retaining Ring	1
7	15-301-08	Pin	1
8		Sleeve	1
9		Retainer	1
10	15-301-11	Plug and O-ring	1
*		O-Ring Seal	1
		Plug	1
11	15-301-12	Relief Valve/Check (1015 psi (70 bar))	1
12		Housing	1
13*		Dust Seal	1
14	15-301-06	Wear Plate	1
15	15-301-07	Drive	1
16	15-301-05	Spacer	1
17	15-301-04	Gerotor	1
18*		O-Ring	1
19*		Seal	1
20	15-301-03	End Cap	1
21	15-301-02	Cap Screw	7
*	15-301-01	Seal Kit	

15-301 ORBITOR SPECIFICATIONS

Maximum System Pressure	1015 psi (70 bar)
Maximum Back Pressure	150 psi (10 bar)
Maximum System Operating Temperature.	200°F (93°C)
Maximum Flow	4 gpm (15 lpm)
Maximum Temperature Differential between Steering Unit and System.	50°F (28°C)
Input Torque Powered	15-25 lb/in @ 100 psi tank pressure (2-3 Nm @ 7 bar)
Input Torque Maximum Non-powered	60 lb/ft (81 Nm)
Rotation Limits	None
Fluid	SAE 10W-40 API Service SJ or higher Motor Oil
Check Valve for Manual Steering	Yes
Relief Valve Setting	1015 psi (70 bar)
Ports	⁹ / ₁₆ - 18 SAE O-Ring 4 Ports
Displacement	61 cu. in/ R (100 cu cm/R)

15-409 3-SPEED TRANSMISSION DRAWING

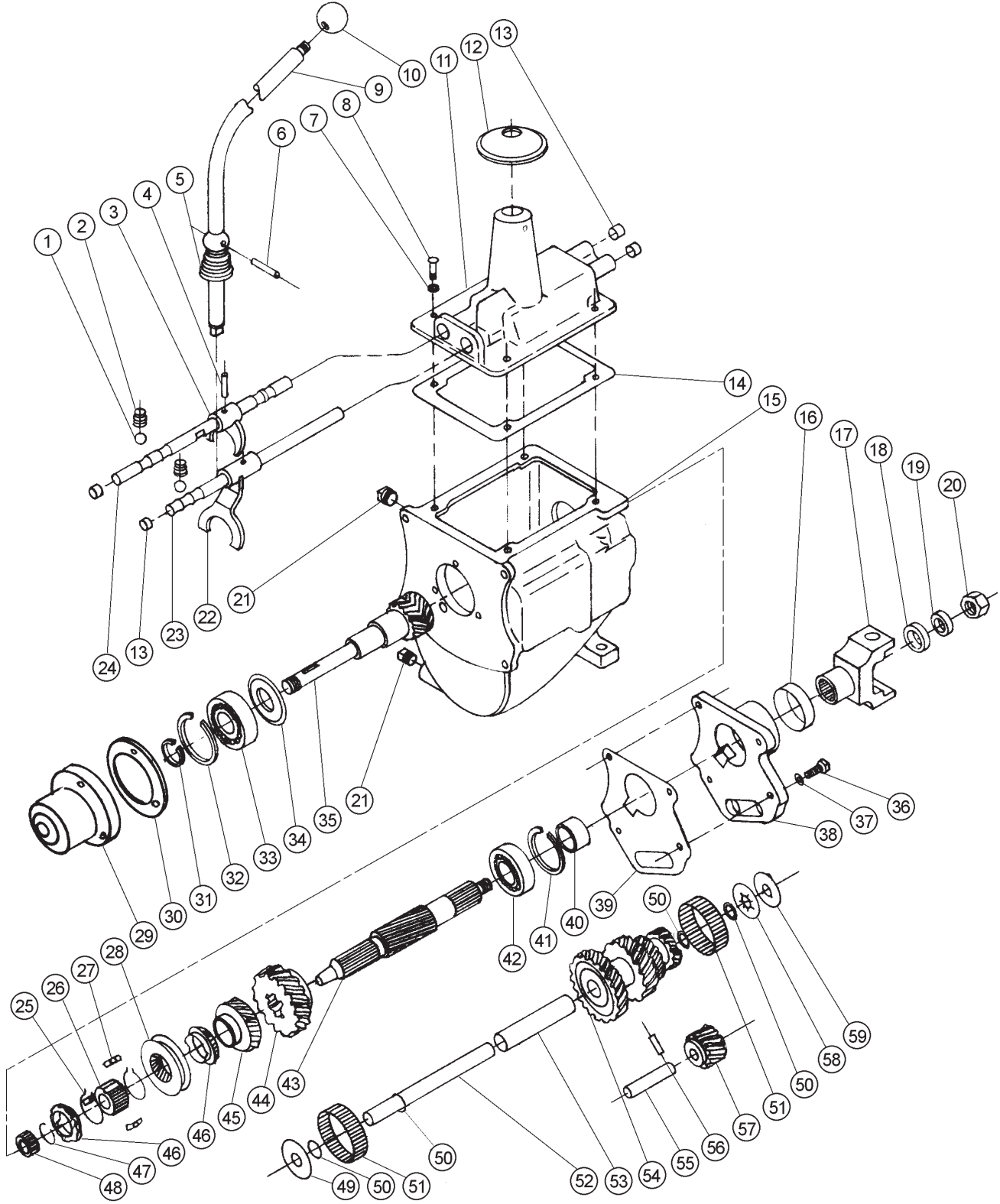

Parts

15-409 3-SPEED TRANSMISSION PARTS LIST

REF#	PART#	DESCRIPTION	QUANTITY
1†	16-341	Ball $\frac{3}{8}$ detent	2
2†	16-342	Poppet Spring	2
3†	16-348	Low & Reverse Shift Fork	1
4†	16-343	Rail Pin	2
5†	16-344	Shift Spring	1
6†	16-308	Pin	1
7†	HWL-516	Lockwasher $\frac{5}{16}$	7
8†	HB-516-18-075	Bolt $\frac{5}{16}$ - 18 x $\frac{3}{4}$	7
9†	15-458	Shift Lever	1
10†	16-259	Shift Knob (not included with 15-409)	1
	16-011	Decal Shift (not included with 15-409)	1
11†	16-301	Transmission Housing Cover	1
12†	16-039	Rubber Rain/Dust Boot (not included with 15-409)	1
13†	16-340	Plug Cap	4
14†	16-302	Housing Cover Gasket	1
15	16-330	Top Shift type Case	1
16	16-313	Seal M/S (rear)	1
17	16-004	Yoke	1
18	16-306	Washer M/S	1
19	HWL-34	Lockwasher $\frac{3}{4}$	1
20	16-307	Nut	1
21	16-336	Drain/Fill Plug	2
22†	16-337	High & Inter. Shift Fork	1
23†	16-338	High & Inter. Shift Rail	1
24†	16-339	Low & Reverse Shift Rail	1
25*	16-351	Syncro Snap Ring	2
26*	16-352	Syncro Hub	1
27*	16-350	Shift Plate	3
28*	16-908	Sleeve	1
29	16-054	Tran. Bearing Housing (not included with 15-409)	1
	16-008	Bearing (part of 16-054)	1
	HB-38-16-125	Bolt $\frac{3}{8}$ - 16 x $1\frac{1}{4}$	3
	HW-38	Washer $\frac{3}{8}$	3
30	16-218	Gasket (not included with 15-409)	1
31	16-335	Snap Ring (small)	1
32	16-334	Snap Ring (large)	1
33	16-333	Bearing M/D Gear	1
34	16-332	Oil Baffle	1
35	16-331	Gear M/D keyed (input shaft)	1
36	16-347	Bolt $\frac{7}{16}$ - 14 x 1 (black)	4
37		Washer $\frac{7}{16}$ (star burst)	4
38	16-314	Rear Bearing Retainer	1
39	16-326	Gasket M/D retainer	1
* †	16-328 16-299	Synchronized Assembly with BR Rings Transmission Cover Assembly	1

(Continued on next page)

15-409 3-SPEED TRANSMISSION DRAWING

Parts

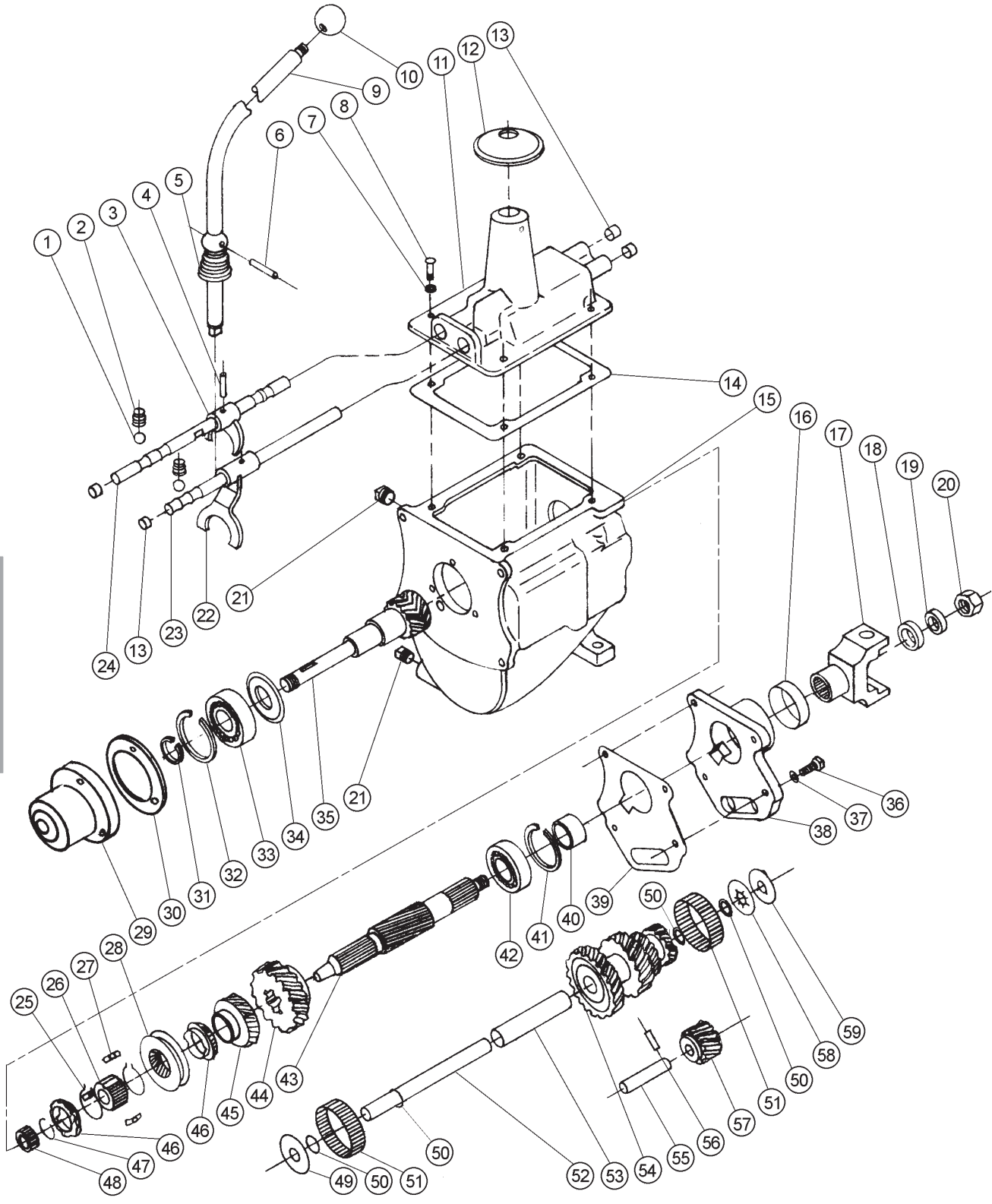

15-409 3-SPEED TRANSMISSION PARTS LIST

40	16-309	Spacer (speedometer)	1
41	16-305	Snap Ring	1
42	16-304	Rear Bearing	1
43	16-303	Main Shaft	1
44	16-310	Gear M/S (low & reverse)	1
45	16-311	Gear M/S (2nd)	1
46*	16-312	Syncro Ring M/S 2nd & 3rd	2
47	16-329	Snap Ring	1
48	16-327	Needle Bearing (13 rollers per set)	1 set
49	16-325	Steel Washer	1
50	16-317	Thrust Washer	4
51	16-318	Main Needle Bearing (20 rollers per set)	2 sets
52	16-324	Cluster Gear Shaft C/S	1
53	16-323	Cluster Spacer Tube	1
54	16-322	Gear C/S (cluster)	1
55	16-321	Reverse Gear Shaft	1
56	16-320	Lockplate	1
57	16-319	Reverse Idler Gear	1
58	16-316	Thrust Washer	1
59	16-315	Thrust Washer	1
*	16-328	Synchronized Assembly with BR Rings	1

16-998 HYPRO PUMP DRAWING

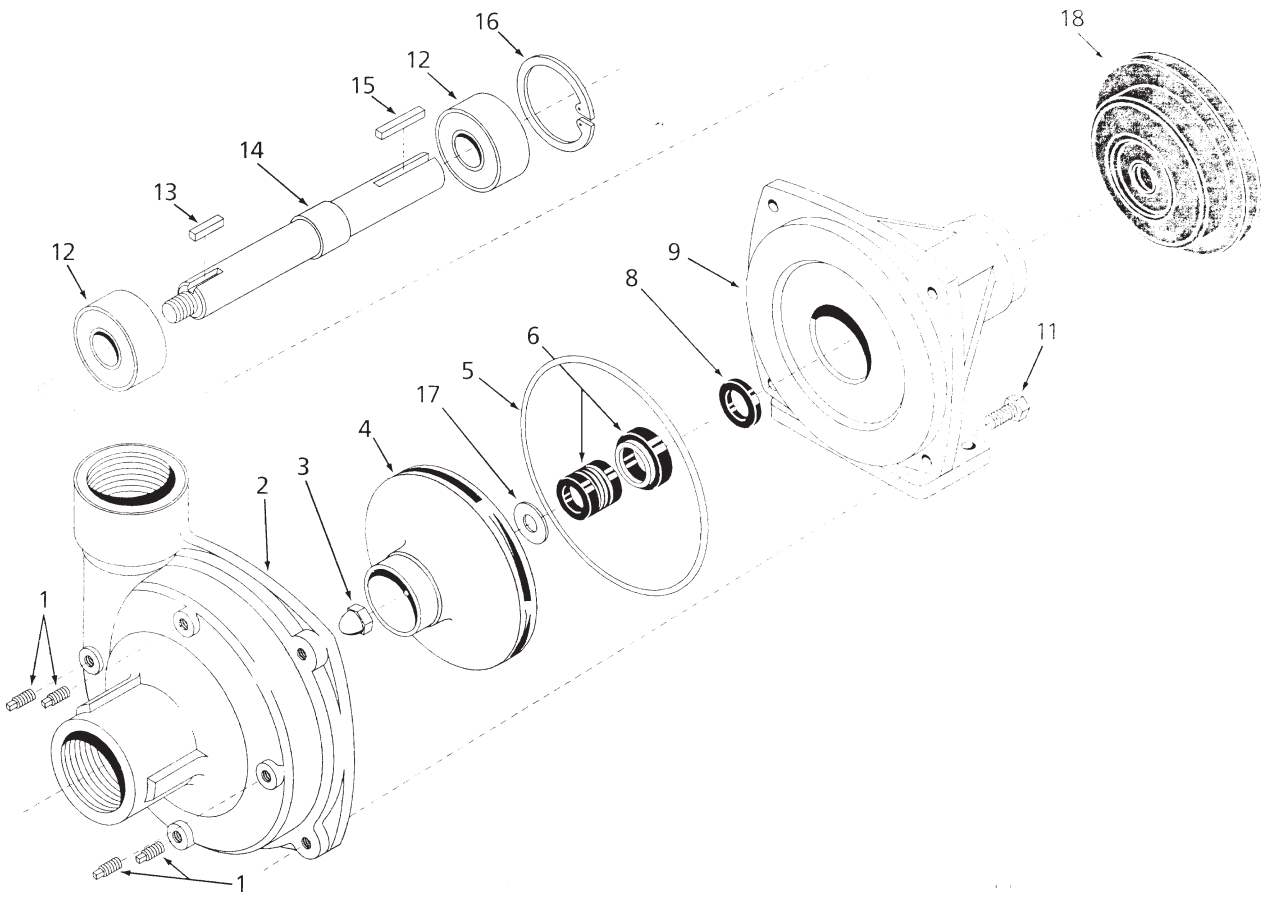

Parts

16-998 HYPRO® PUMP PARTSLIST

REF#	PART#	DESCRIPTION	QUANTITY
1	16-998-01	Drain Plug	4
2	16-998-02	Pump Casing	1
3	16-998-03	Impeller Nut	1
4	16-966-16	Impeller	1
5*	16-467	O-Ring	1
6*	16-998-05	Mechanical Seal (Silicon Carbide)	1
8*	16-966-06	Slinger Ring	1
9	16-998-06	Mounting Flange	1
11	16-998-07	Bolt	4
12	16-966-10	Ball Bearing	2
13	16-998-08	Key	1
14	16-998-09	Pump Shaft	1
15	16-822-20	Key	1
16	16-966-13	Bearing Retainer	1
17*	16-998-10	Gasket	1
18	16-994-01	Clutch	1
	16-998-12	Pump Only	
*	16-967	Silicone - Carbon Seal Kit	

When servicing the spray pump or filter, all control valves must be shut off if there is liquid in the tank.

16-037 REAR AXLE DRAWING

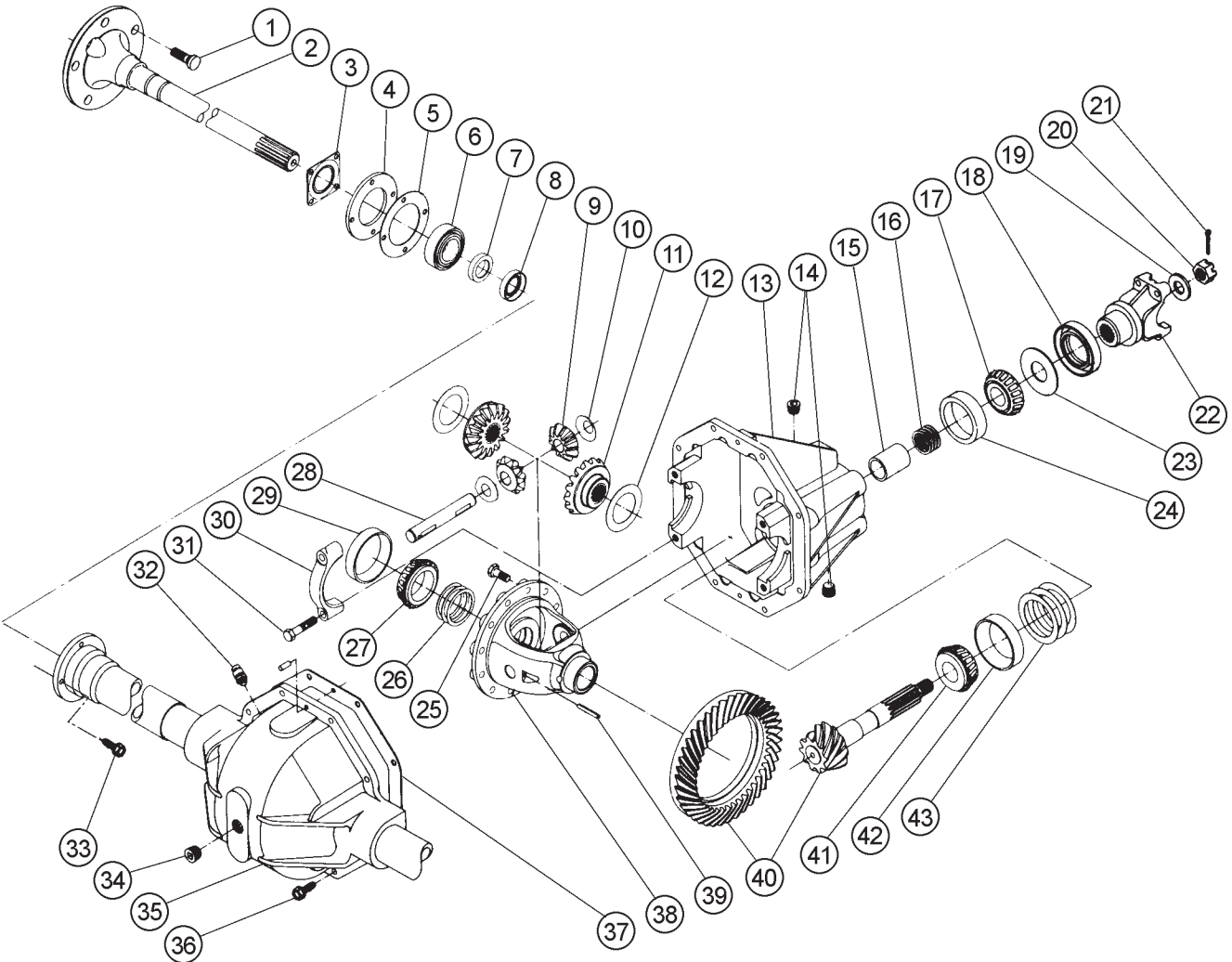

Parts

16-037 REAR AXLE PARTS LIST

REF#	PART#	DESCRIPTION	QUANTITY
1	16-510	Wheel Bolt	10
	16-562	Lock Nut	2
2	16-511	Axle Shaft (Left and Right)	2
3	16-513	Oil Seal	2
4		Part of Brake Dust Shield	
5	16-518	RTV Gasket Eliminator (Loctite Brand)	As Required
6	16-515	Bearing	2
7	16-516	Wheel Bearing Retainer Ring	2
8	16-519	Oil Seal	2
9	16-495	Pinion Mate	2
10	16-496	Thrust Washer	2
11	16-494	Side Gear	2
12	16-493	Thrust Washer	2
13	16-501	Carrier	1
14	16-502	Oil Plug	2
15	16-503	Sleeve Spacer	1
16	16-504	Shim (Set of 4)	2-4
17	16-506	Bearing Cone	1
18	16-508	Oil Seal	1
19	16-816	Flat Washer	1
20	HNA-58-18	Axle Nut $\frac{5}{8}$ - 18	1
21	HP-18-150	Cotter Pin $\frac{1}{8}$ x $1\frac{1}{2}$	1
22	16-509	End Yoke	1
23	16-507	Shim	1
24	16-505	Bearing Cup	1
25	16-489	Drive Gear Screw	14
26	16-488	Shim (Set of 4)	4-6
27	16-487	Bearing Cone	2
28	16-492	Pinion Mate Shaft	1
29	16-486	Bearing Cup	2
30		Bearing Cap	
31	16-484	Bearing Cup Screw	4
32	16-481	Vent Assembly	1
33	16-963	Bolt Kit (Includes Bolt, Washer, and Nut (Replace all 8 when replacing one))	8
34	18-069	Plug $\frac{1}{2}$ NPT	1
35	16-480	Rear Axle Housing	1
36	16-815	Housing Bolt	8
	16-561	Hex Nut	8
	16-563	Lockwasher	8
37	16-482	RTV Sealant	As Required
38	16-490	Differential Case	1
39	16-491	Pinion Lock Pin	1
40	16-497	Gear and Pinion Assembly 12.25:1 Ratio (Matched Set)	1
41	16-498	Bearing Cone	1
42	16-499	Bearing Cup	1
43	16-500	Spacer (Set of 3)	2-4

16-037 Includes Brakes and Drums



BRAKE ASSEMBLY DRAWING

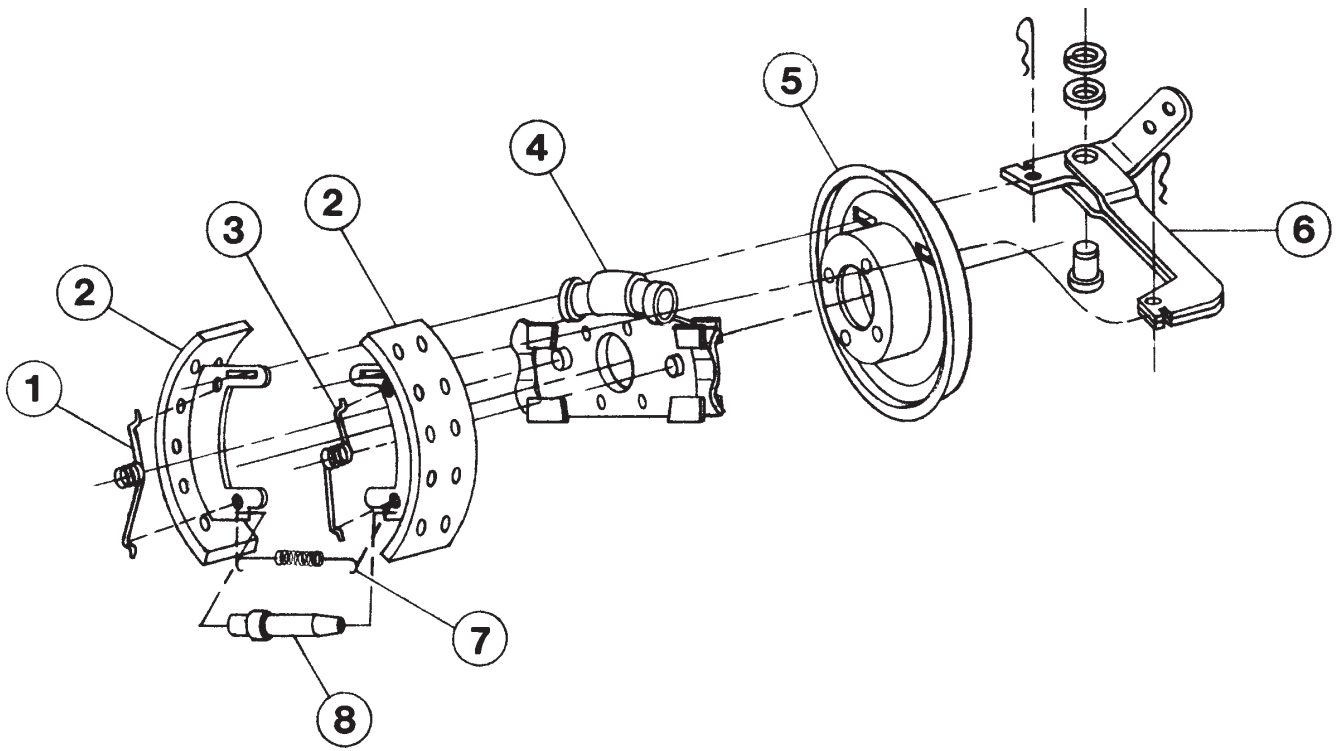

Parts

BRAKE ASSEMBLY PARTS LIST

REF#	PART#	DESCRIPTION	QUANTITY
1	16-704	Shoe Return Spring (Green)	1
2	16-725	Shoe and Lining Kit	2 sets required
3	16-705	Shoe Return Spring (Red)	1
4	16-723	Spider Torque Kit	1
5	16-709	Dust Shield and Bearing Retainer	1
6	16-713	Brake Lever Kit (Right or Left)	1
7	16-719	Adjusting Spring	1
8	16-720	Adjusting Screw Kit	1
	16-514	Left Brake Assembly (part of 16-037)	1
	16-554	Right Brake Assembly (part of 16-037)	1
	16-559	Brake Drum (part of 16-037)	2
	16-723-01	Cylinder Kit (Includes Boot and Cup)	2 per cylinder

1. For Left brake, assembly with star wheel of adjusting screw (Ref# 8) towards the front of the brake (as shown), opposite for Right brake.
2. Red Spring- Assemble to front of brake on right side assembly, opposite for left.
3. Green Spring - Assemble to rear of brake on right side assembly, opposite for left.
4. Brake actuating lever (Ref# 6) shown for right assembly, reverse for left assembly. Bent arm stays up, double arm switches to forward.

1602P PLUMBING (RAVEN 440)

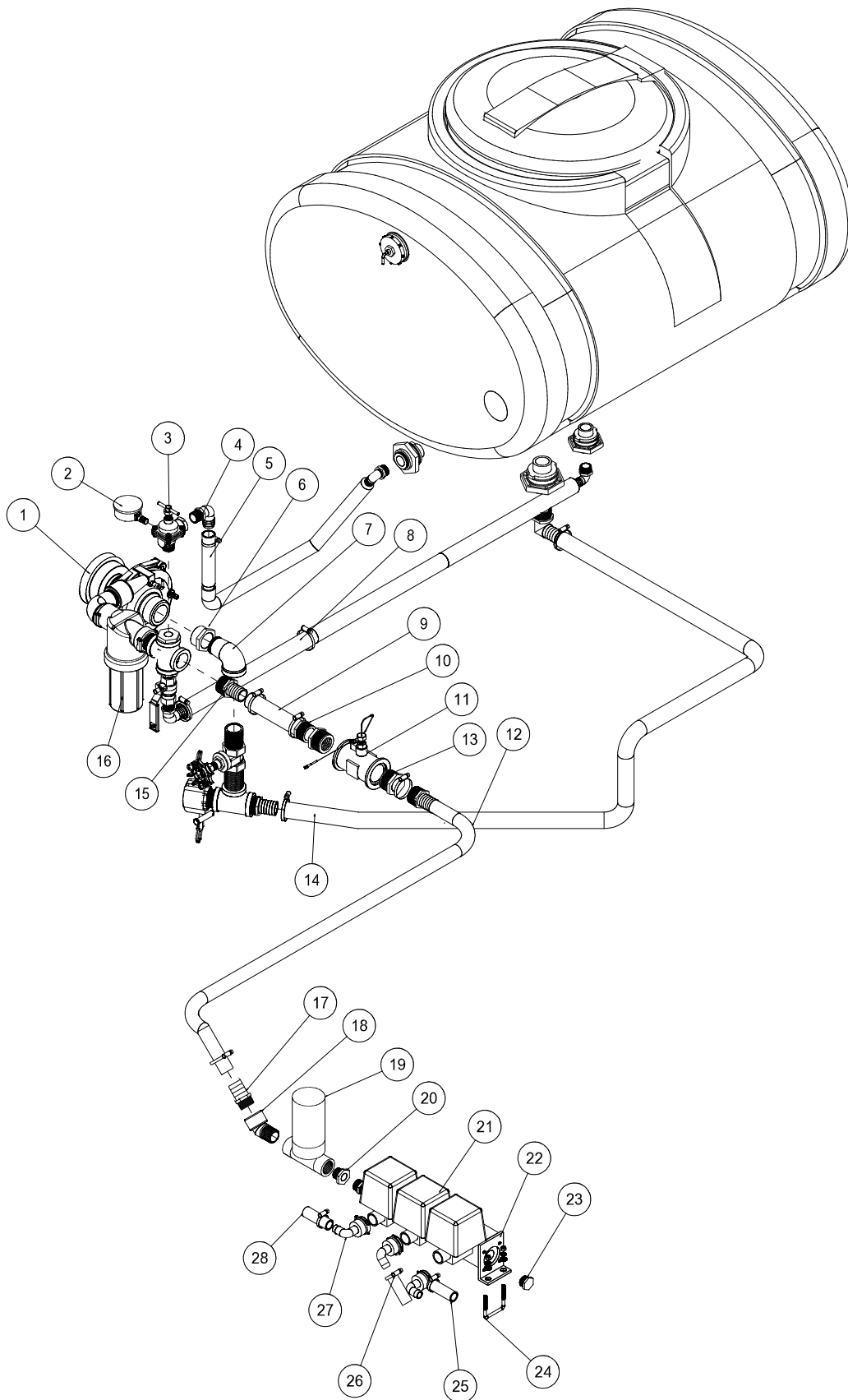

Accessories

1602P SYSTEM (RAVEN 440)

REF#	PART#	DESCRIPTION	QUANTITY
1	16-998	Hypro® Pump	1
2	16-281	Liquid Filled Gauge	1
3	16-034	Throttling Valve	1
	16-034-01	Spare Parts Kit (for 16-034)	1
4	16-155	Elbow 3/4 MPT x 1 HB	1
5	8896-27	Discharge Hose 1"	1
	18-222	Hose Clamp ¹³ / ₁₆ x 1 ¹ / ₂	2
6	16-825	Reducer Bushing 1 ¹ / ₂ x 1 ¹ / ₄	1
7	16-972	Elbow 1 ¹ / ₄	2
8	8896-30	Discharge Hose 1"	1
	18-222	Hose Clamp ¹³ / ₁₆ x 1 ¹ / ₂	2
9	8897-12	Discharge Hose 1 ¹ / ₄ "	1
	18-116	Hose Clamp HS-24	2
10	16-161	Barb Fitting	2
11	18-373	Flow Meter	1
	18-373-01	Sensor	1
12	8897-24	Discharge Hose 1 ¹ / ₄	1
	18-116	Hose Clamp HS-24	2
13	16-973	Reducer	2
14	8897-23	Discharge Hose 1 ¹ / ₄	1
	18-116	Hose Clamp HS-24	2
15	16-161	Fitting 1 ¹ / ₄ MPT x 1 ¹ / ₄ HB	1
16	14-521	Strainer	1
17	16-159	Fitting 1 MPT X 1 ¹ / ₄ HB	1
18	16-971	45° Elbow 1 FPT x 1 MPT	1
19	16-524	Motorized Control Valve	1
20	16-851	Close Nipple	1
21	15-552	Manifold Ball Valve	1
22	15-552-07	Steel Mounting Bracket (comes with 15-552)	2
23	16-162	Pipe Plug	1
24	10-194	U-Bolt	2
	HNTL-14-20	Lock Nut ¹ / ₄ -20	4
	HW-14	Washer ¹ / ₄	4
25	8887-40	Orange PVC Hose ³ / ₄ x 40" (to right boom)	1
	18-040	Hose Clamp HS-12	1
26	8887-35	Orange PVC Hose ³ / ₄ x 35" (to center boom)	1
	18-040	Hose Clamp HS-12	1
27	15-553	³ / ₄ - 90° Hose Barb (comes with 15-552)	3
	15-553-01	Clip	3
	15-553-02	O-Ring	3
28	8887-37	Orange PVC Hose ³ / ₄ x 37" (to left boom)	1
	18-040	Hose Clamp HS-12	1

1604P SYSTEM (RAVEN 203)

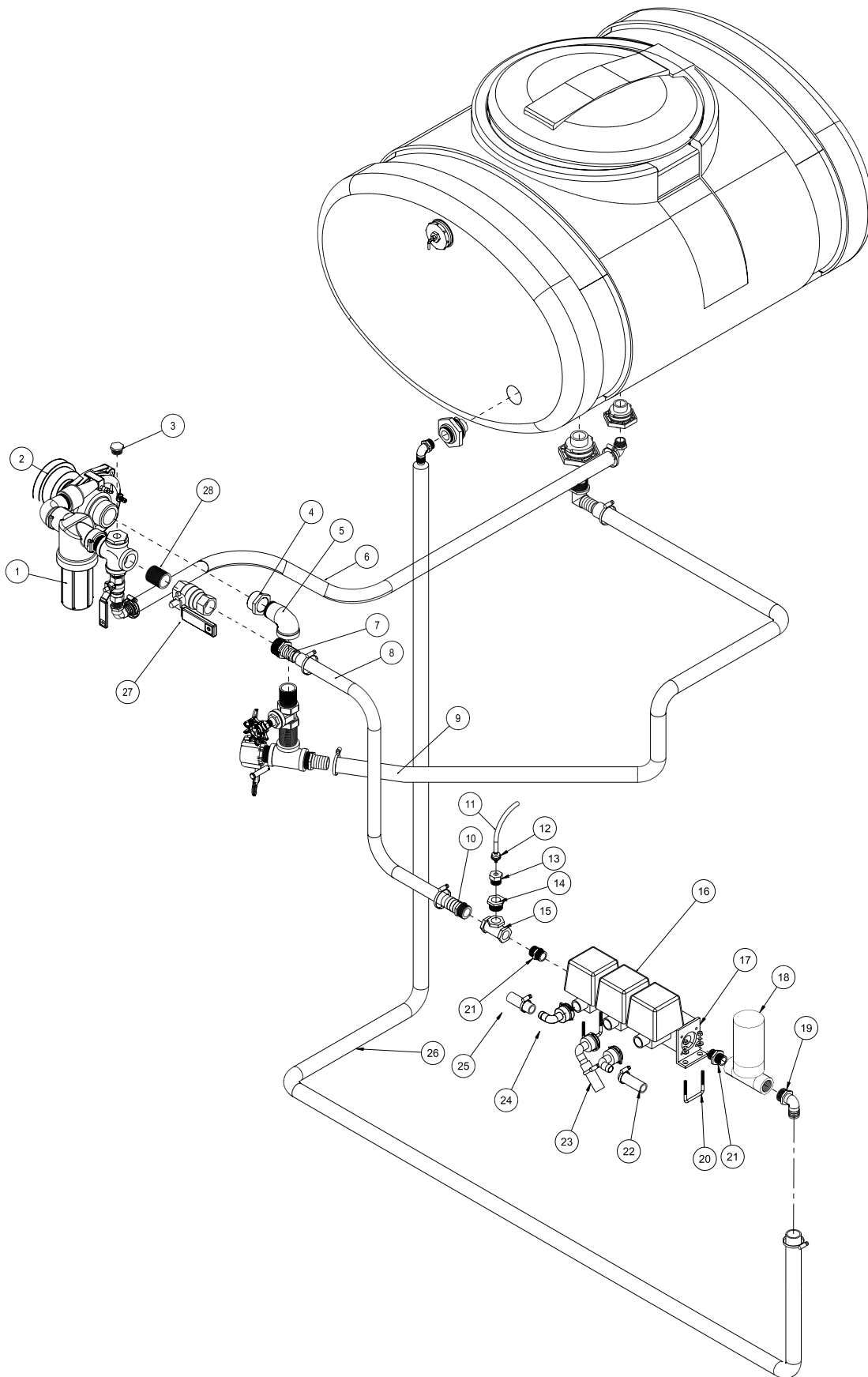

Accessories

REF#	PART#	DESCRIPTION	QUANTITY
1	14-521	Strainer	1
2	16-998	Hypro® Pump	1
3	16-166	Hex Plug $\frac{3}{4}$ MPT	1
4	16-825	Reducer Bushing $1\frac{1}{2}$ x $1\frac{1}{4}$	1
5	16-972	Elbow $1\frac{1}{4}$	1
6	8896-30	Discharge Hose 1" x 30"	1
	18-222	Hose Clamp $\frac{13}{16}$ x $1\frac{1}{2}$	2
7	16-161	Fitting $1\frac{1}{4}$ MPT x $1\frac{1}{4}$ HB	1
8	8897-44	Discharge Hose $1\frac{1}{4}$ " x 44"	1
	18-116	Hose Clamp HS-24	2
9	8897-23	Discharge Hose $1\frac{1}{4}$ x 23"	1
	18-116	Hose Clamp HS-24	2
10	16-159	Fitting 1 MPT x $1\frac{1}{4}$ HB	1
11	16-955	Tube	1
12	16-958-07	Male Fitting	1
13	16-288	Reducer Bushing $\frac{3}{4}$ x $\frac{1}{4}$	1
14	16-163	Reducer Bushing 1 x $\frac{3}{4}$	1
15	16-183	Tee FPT 1 x 1 x 1	1
16	15-552	Manifold Ball Valve	1
17	15-552-07	Steel Mounting Bracket (comes with ball valve)	2
18	16-524	Motorized Control Valve	1
19	16-164	Elbow 1 MPT x 1HB	1
20	10-194	U- Bolt	2
	HW-14	Washer $\frac{1}{4}$	4
	HNTL-14-20	Lock Nut $\frac{1}{4}$ - 20	4
21	16-851	Close Nipple	2
22	8887-40	Orange PVC Hose $\frac{3}{4}$ " x 40" (to right boom)	1
	18-040	Hose Clamp HS-12	1
23	8887-35	Orange PVC Hose $\frac{3}{4}$ " x 35" (to center boom)	1
	18-040	Hose Clamp HS-12	1
24	15-553	Hose Barb $\frac{3}{4}$ - 90° (comes with ball valve)	3
	15-553-01	Clip (part of 15-553)	3
	15-553-02	O-ring (part of 15-553)	3
25	8887-37	Orange PVC Hose $\frac{3}{4}$ " x 37" (to left Boom)	1
	18-040	Hose Clamp HS-12	1
26	8896-66	Discharge Hose 1" x 66"	1
	18-222	Hose Clamp $\frac{13}{16}$ x $1\frac{1}{4}$	2
27	18-279	Ball Valve $1\frac{1}{4}$ "	1
28	18-160	Close Nipple $1\frac{1}{4}$ "	1

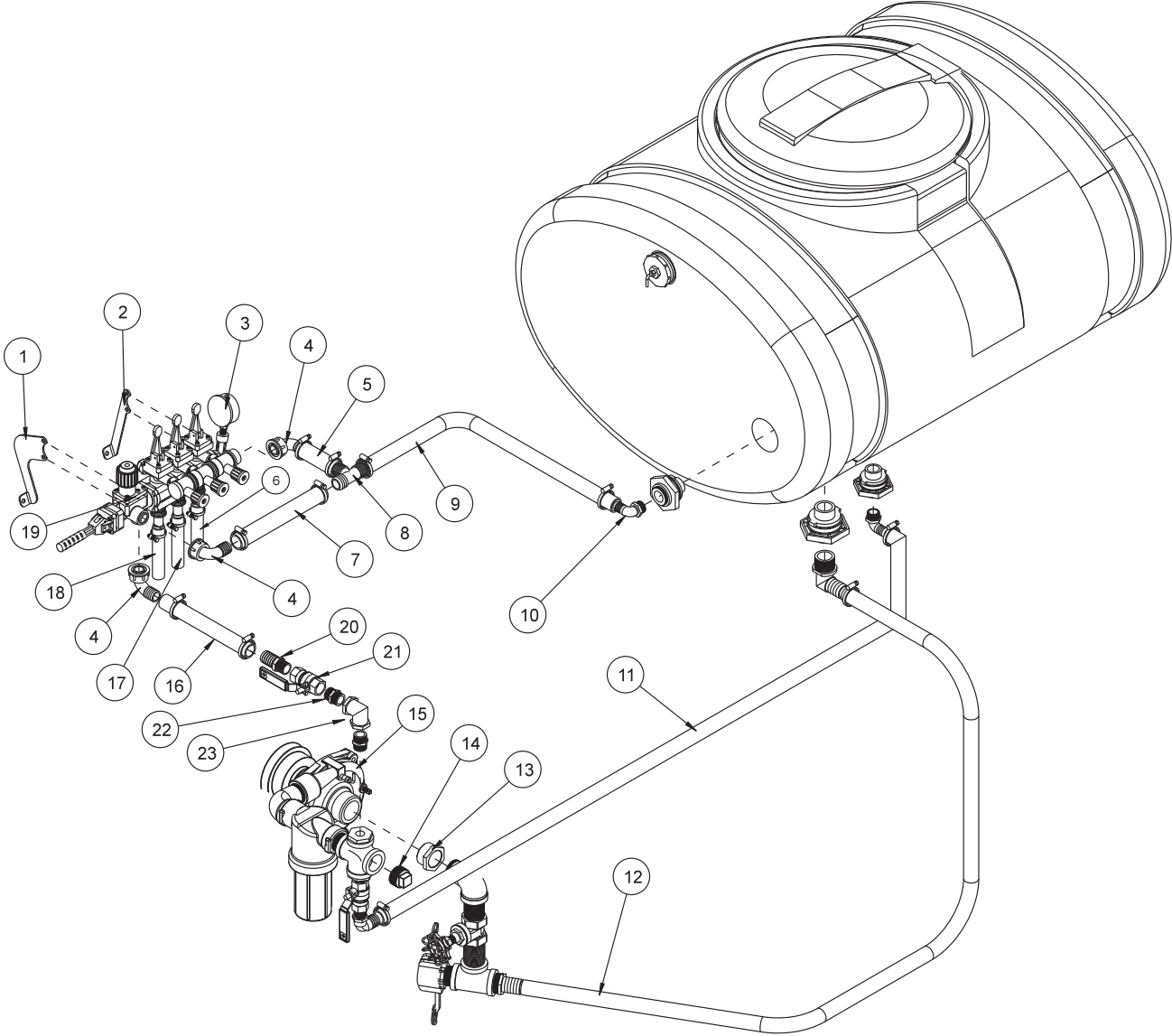

Accessories

REF#	PART#	DESCRIPTION	QUANTITY
1	10-263	Front Valve Bracket	1
2	10-264	Rear Valve Bracket	1
3	16-281	Liquid Filled Gauge	1
4	16-268-13	90° Elbow x 1HB with Nut (comes with 10-268 Valve)	3
5	8896-4	Discharge Hose 1" x 4"	1
	18-222	Hose Clamp $1\frac{3}{16}$ x $1\frac{1}{2}$	2
6	8887-122	Orange PVC Hose $\frac{3}{4}$ " x 122" (right boom)	1
	18-040	Hose Clamp HS-12	1
7	8896-10	Discharge Hose 1" x 10"	1
	18-222	Hose Clamp $1\frac{3}{16}$ x $1\frac{1}{2}$	2
8	10-269	Plastic Tee 1 x 1 x 1HB	1
9	8896-20	Discharge Hose 1" x 20"	1
	18-222	Hose Clamp $1\frac{3}{16}$ x $1\frac{1}{2}$	2
10	16-155	Elbow $\frac{3}{4}$ MPT x 1 HB	1
11	8896-30	Discharge Hose 1" x 30"	1
	18-222	Hose Clamp $1\frac{3}{16}$ x $1\frac{1}{2}$	2
12	8897-23	Discharge Hose $1\frac{1}{4}$ " x 23"	1
	18-116	Hose Clamp HS-24	2
13	16-825	Reducer Bushing $1\frac{1}{2}$ x $1\frac{1}{4}$	1
14	18-098	Pipe Plug	1
15	16-998	Hypro® Pump	1
16	8896-32	Discharge Hose 1" x 32"	1
	18-222	Hose Clamp $1\frac{3}{16}$ x $1\frac{1}{2}$	2
17	8887-109	Orange PVC Hose $\frac{3}{4}$ " x 109" (center boom)	1
	18-040	Hose Clamp HS-12	1
18	8887-130	Orange PVC Hose $\frac{3}{4}$ " x 130" (left boom)	1
	18-040	Hose Clamp HS-12	1
19	10-268	3 Way Manual Valve	1
20	16-196	Hose Barb $\frac{3}{4}$ MPT x 1 HB	1
21	16-859	Ball Valve $\frac{3}{4}$ Brass	1
22	16-158	Close Nipple $\frac{3}{4}$	2
23	16-151	Elbow FPT $\frac{3}{4}$	1



CONTROLS 1602P SYSTEM (RAVEN 440)

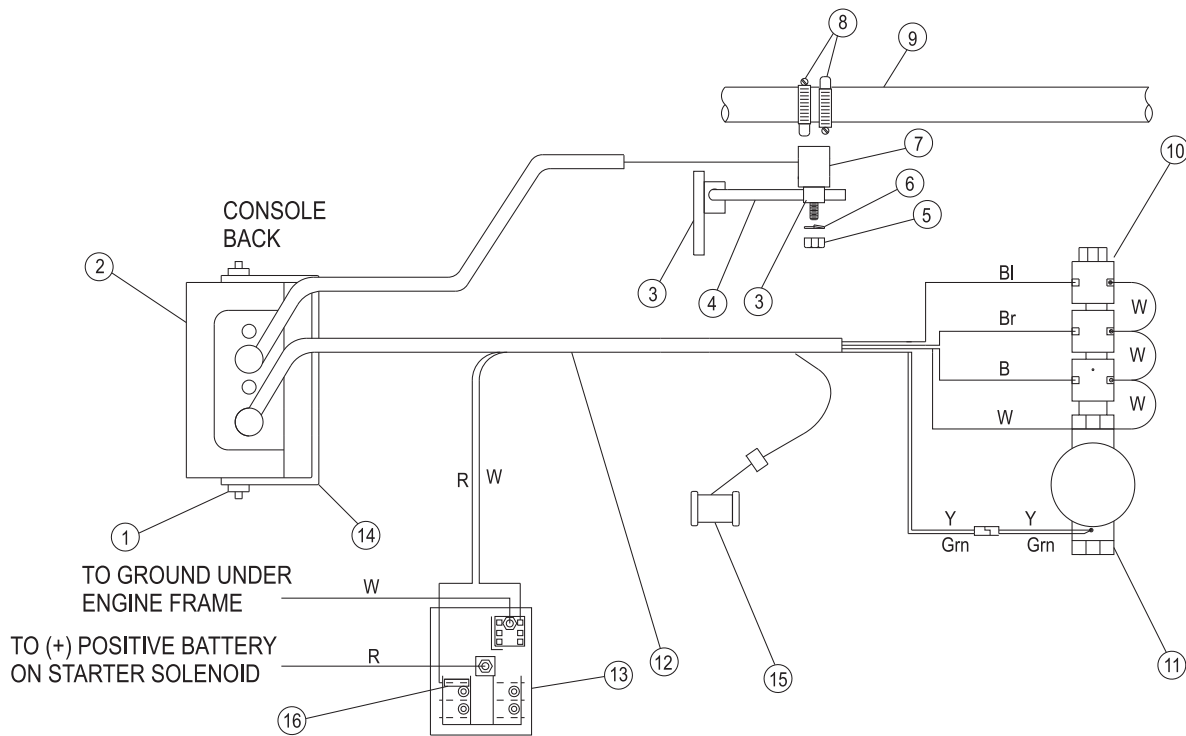

REF#	PART#	DESCRIPTION	QUANTITY
1	16-558	Mounting Knob	2
2	16-525	Console (only)	1
3*	15-370-03	Turret Assembly	2
4*	15-370-04	Speed Sensor Rod	1
5*	HN-14-20	Nut 1/4 - 20	2
6*	HWL-14	Lockwasher 1/4	2
7	16-139	7' Magnetic Sensor Cable'	1
	15-365-01	10' Magnetic Sensor Cable	1
8*	15-370-01	Red Magnet Assembly north	1
*	15-370-02	Black Magnet Assembly south	1
*	15-370-07	Small Band Clamp	2
9	14-370	Drive Line (Spray Star)	1
10	15-552	Manifold Valve	1
11	16-524	Motorized Control Valve	1
12	15-369	Console Control Cable	1
13	33-271	Fuse Block	1
14	10-237	Mounting Bracket	1
15	18-373	Flow Meter	1
16	33-508	Auto Blade Type Fuse 15 amp	1
*	15-370-08	Drive Shaft Hardware Kit (for speed sensor)	

Use Dielectric Grease On All Electrical Connections

CONTROL 1604P SYSTEM (RAVEN 203)

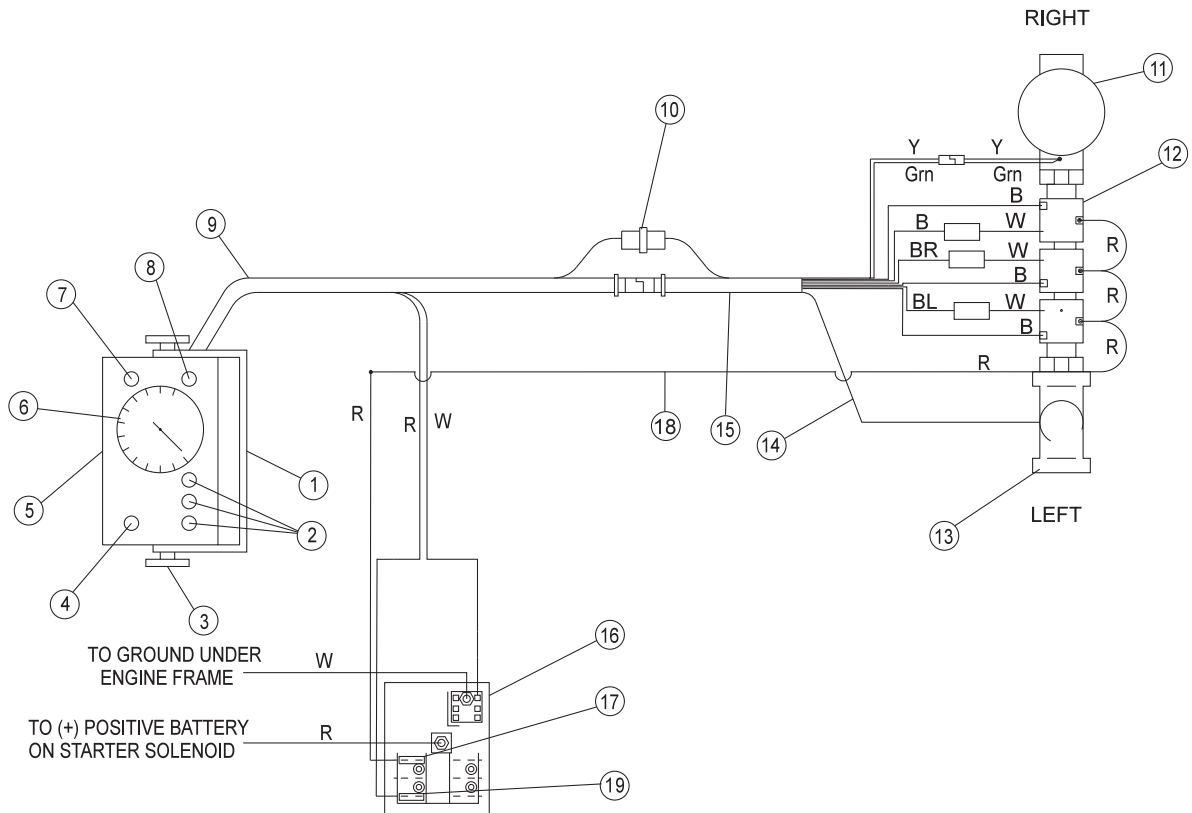

REF#	PART#	DESCRIPTION	QUANTITY
1	16-958-01	Mounting Bracket	1
2	16-898	Boom Switch	3
3	16-900	Mounting Knob	2
4	16-899	Master Switch	1
5	18-418	Console with Liquid Filled Pressure Gauge	1
6	33-090-02	Liquid Filled Pressure Gauge	1
	33-090-04	Pressure Gauge Tube Fitting	1
7	16-958-02	Fuse Holder	1
	16-525-03	Fuse 15 AMP	1
8	16-895	Pressure Switch	1
9	16-958-04	Cable Assembly 8ft Enclosure Hook-Up	1
10	16-958-05	Union Fitting	1
11	16-524	Motorized Control Valve	1
12	15-552	Manifold Ball Valve	1
13	16-183	Tee FPT 1 x 1 x 1	1
14	16-955	Tubing	1
15	16-902	Cable Assembly 72" Solenoid Hook-Up	1
16	33-271	Fuse Block	1
17	33-562	Auto Blade Type Fuse 40 amp	1
18	10-225	Wire Harness (fuse block to electric valve)	1
19	33-508	Auto Blade Type Fuse 15 Amp	1

Use Dielectric Grease On All Electrical Connections

16-524 MOTORIZED CONTROL VALVE

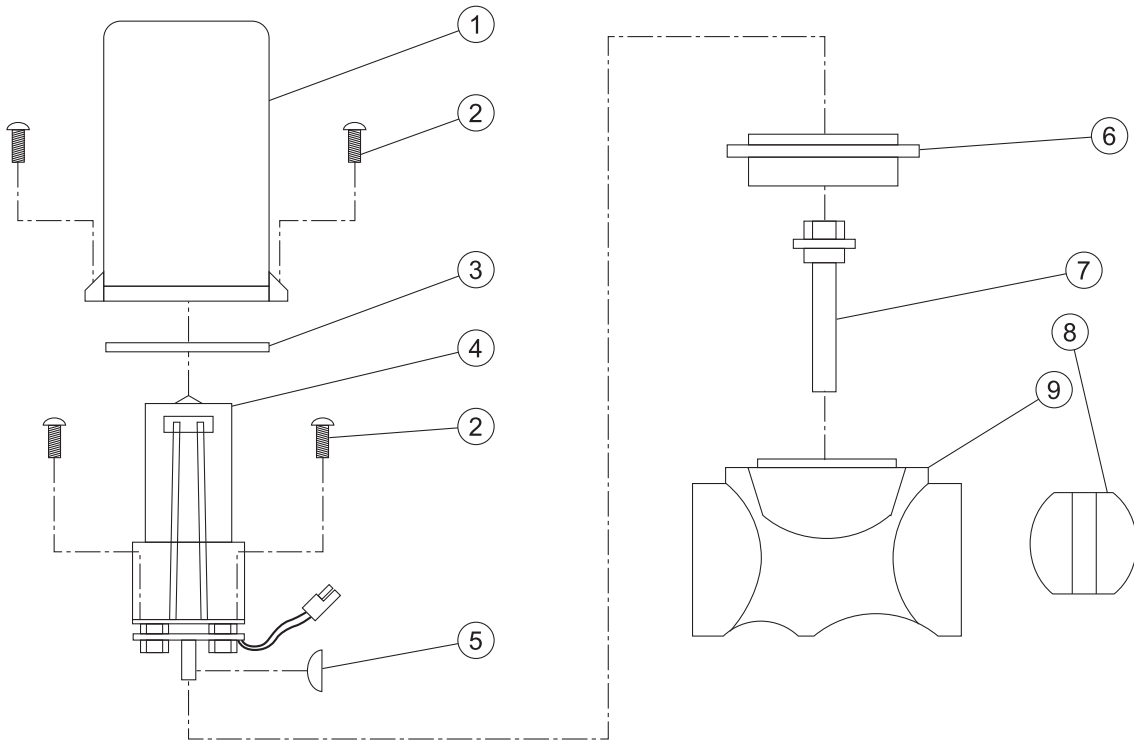

REF#	PART#	DESCRIPTION	QUANTITY
1	16-870	Valve Cover	1
2*	16-524-01	#6 Self Tapping Screw 3/4" Long	6
3	16-897	Seal Tetraseal	1
4	16-875	Motor Assembly	1
5*	16-957	Woodruff Key	1
6*	16-524-04	Isolation Flange Assembly	1
7*	16-524-02	Coupler Shaft	1
8*	16-956	Butterfly	1
9*	16-524-03	Valve Body Assembly	1
*	16-524-05	1" Valve ISO-Body Kit	

WHEN SERVICING VALVE:

Replace valve body with ISO-Body Kit if valve has been leaking internally.

Replace motor assembly if the motor will not run or if the printed circuit board is corroded.

Before reassembling valve, remove the coupler shaft from the valve body. Apply Loctite to coupler shaft and woodruff key. Place the coupler shaft (Ref 7) and the woodruff key (Ref 5) onto the motor shaft. Plug motor into the valve connector coming from Sprayer Control Console. Check that the motor rotates in both directions. Motor must stop when coupler CAM releases printed circuit board switch button.

When reassembling valve, grease both sealing surfaces of coupler shaft. Insert coupler shaft into Iso-flange and be sure seal properly seats on shaft. Install on valve body and apply RTV 738 to mounting holes. Reassemble remaining items as shown in parts diagram on opposite side.

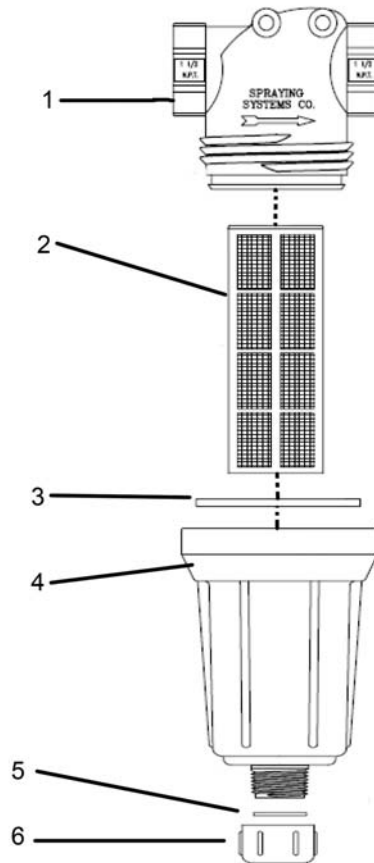

REF#	PART#	DESCRIPTION	QUANTITY
1	14-521-01	Strainer Head 1-1/4FPT	1
2	16-968-03	50 MESH Strainer	1
3	14-521-02	EPDM Gasket	1
4	14-521-03	Bowl 1" NPT	1
5	14-521-04	EPDM Rubber gasket	1
6	14-521-05	Cap	1

10-268 3-WAY MANUAL VALVE

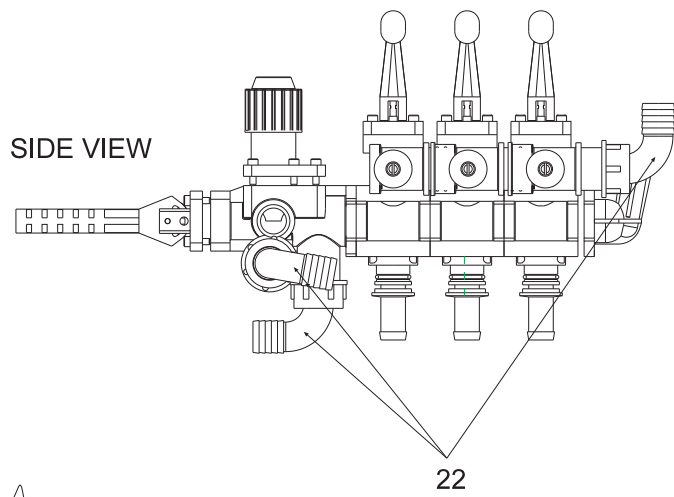
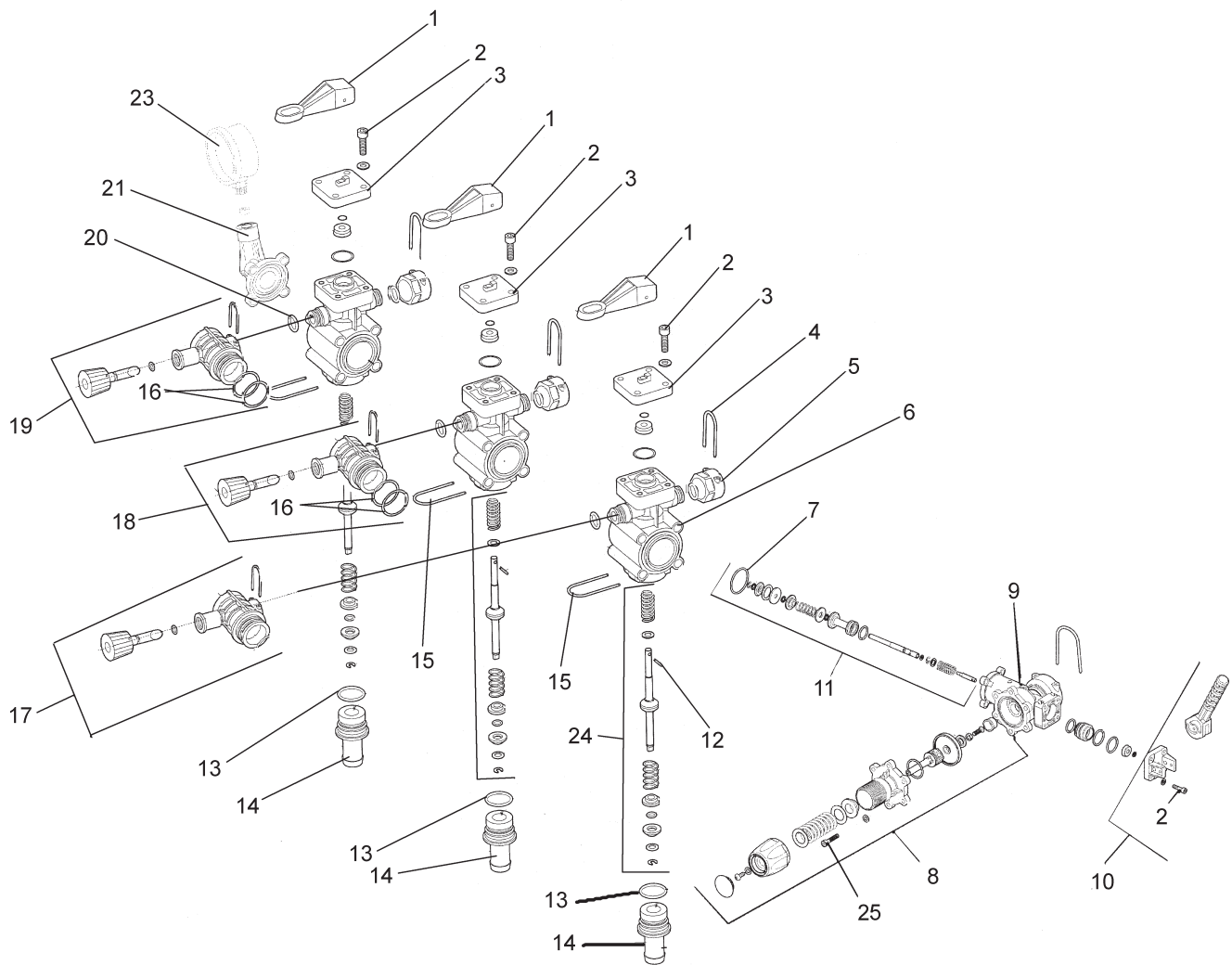

Accessories

10-268 3-WAY MANUAL VALVE

REF#	PART#	DESCRIPTION	QUANTITY
1	10-268-07	Boom Lever	3
2	10-268-16	Bolt and Washer	18
3	10-268-17	Boom Lever Plate	3
4	10-268-06	Spring Clip ^{5/8}	6
5	10-268-05	Cap	3
	10-268-21	O-Ring(included with 10-268-19 Seal Kit)	3
6	10-268-02	Main Body	3
	10-268-19	Seal Kit	1 per body
7	10-268-24	O-Ring for Main Body	3
8	10-268-27	Main Pressure Adjust	1
9	10-268-29	Pressure Adjust Body	1
10	10-268-09	Main Boom Lever	1
11	10-268-30	Master Boom Lever Guts	1
12	10-268-25	Boom Lever Pin	3
13	10-268-22	O-Ring(included with 10-268-19 Seal Kit)	3
14	10-268-03	Hose Barb ^{3/4}	3
15	10-268-04	Spring Clip ^{7/8}	3
16	10-268-23	O-Ring(included with 10-268-12 and 10-268-14)	4
17	10-268-11	Boom Pressure Adjust(threaded end)	1
18	10-268-12	Boom Pressure Adjust(middle)	1
19	10-268-14	Boom Pressure Adjust(capped)	1
20	10-268-21	O-Ring	3
21	10-268-01	Gage Elbow	1
22	10-268-13	Elbow 90° 1" Hose Barb w/ Nut	3
23	16-281	Liquid Filled Gauge(not included with 10-268 valve)	1
24	10-268-26	Boom Lever Guts	3
25	10-268-28	Bolt & Washer	6
Not Shown	10-268-15	Tie Rod with Nuts and Washer	4

15-552 VALVE

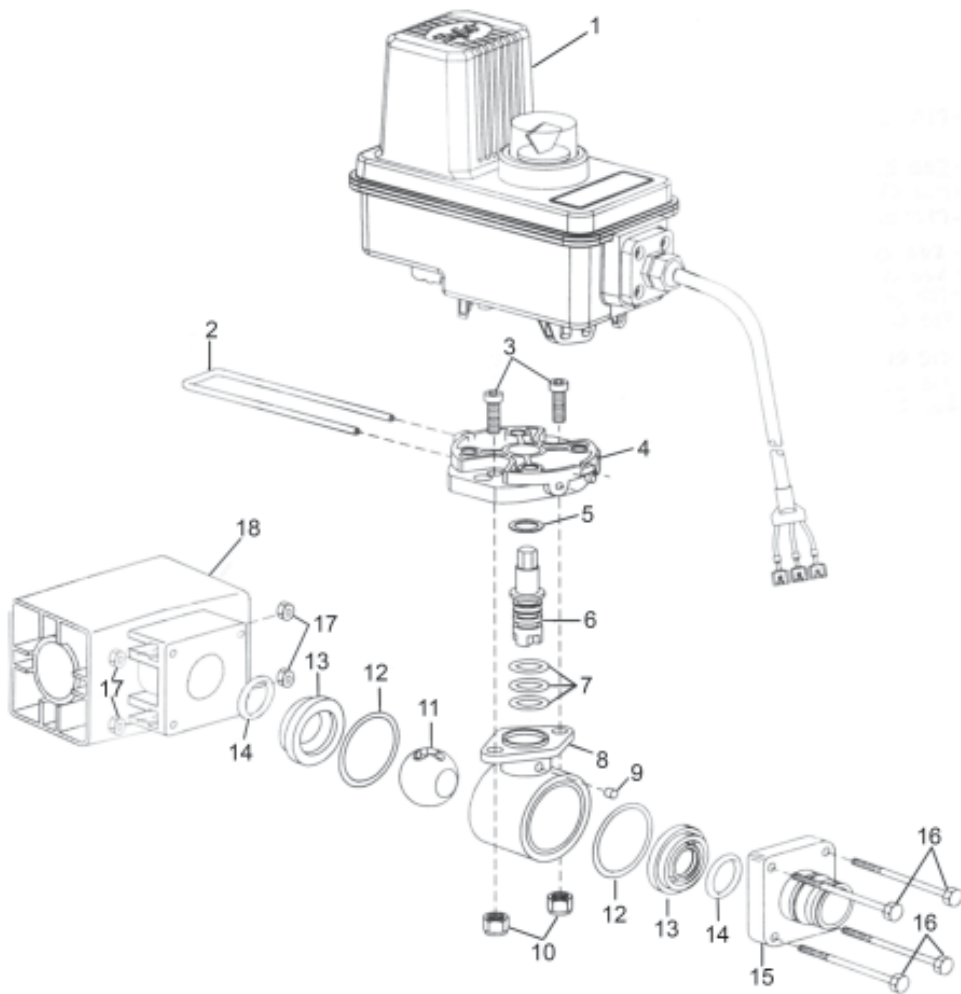

Accessories

REF#	PART#	DESCRIPTION	QUANTITY
1	15-552-23	Motor	
2	15-552-24	Retaining Clip	1
3	15-552-25	Socket Head Cap Screw, Stainless Steel	2
4	15-552-26	Motor Adapter, Polypropylene	1
5*	15-517-11	Thrust Washer, Teflon	1
6	15-552-27	Stem, Stainless Steel	1
7*	15-552-05	O-ring, Viton	3
8	15-517-16	Body, Nylon	1
9*	15-517-17	Dust Plug, Felt	1
10		Lock Nut, Stainless Steel	2
11	15-743-04	Ball, Polypropylene	1
12*	15-552-13	Gasket, Viton	2
13*	15-517-19	Seal, teflon	2
14*	15-517-20	O-ring, Viton	2
15	15-552-17	End Cap	1
16	15-517-22	Hex Head Cap Screw, Stainless Steel	4
17	15-517-23	Hex Nut, Stainless Steel	4
18	15-552-11	Manifold Body	1
*	15-552-10	Spare Parts Kit (includes all * items)	

10-160 STAINLESS STEEL 15' MANUAL BOOM DRAWING

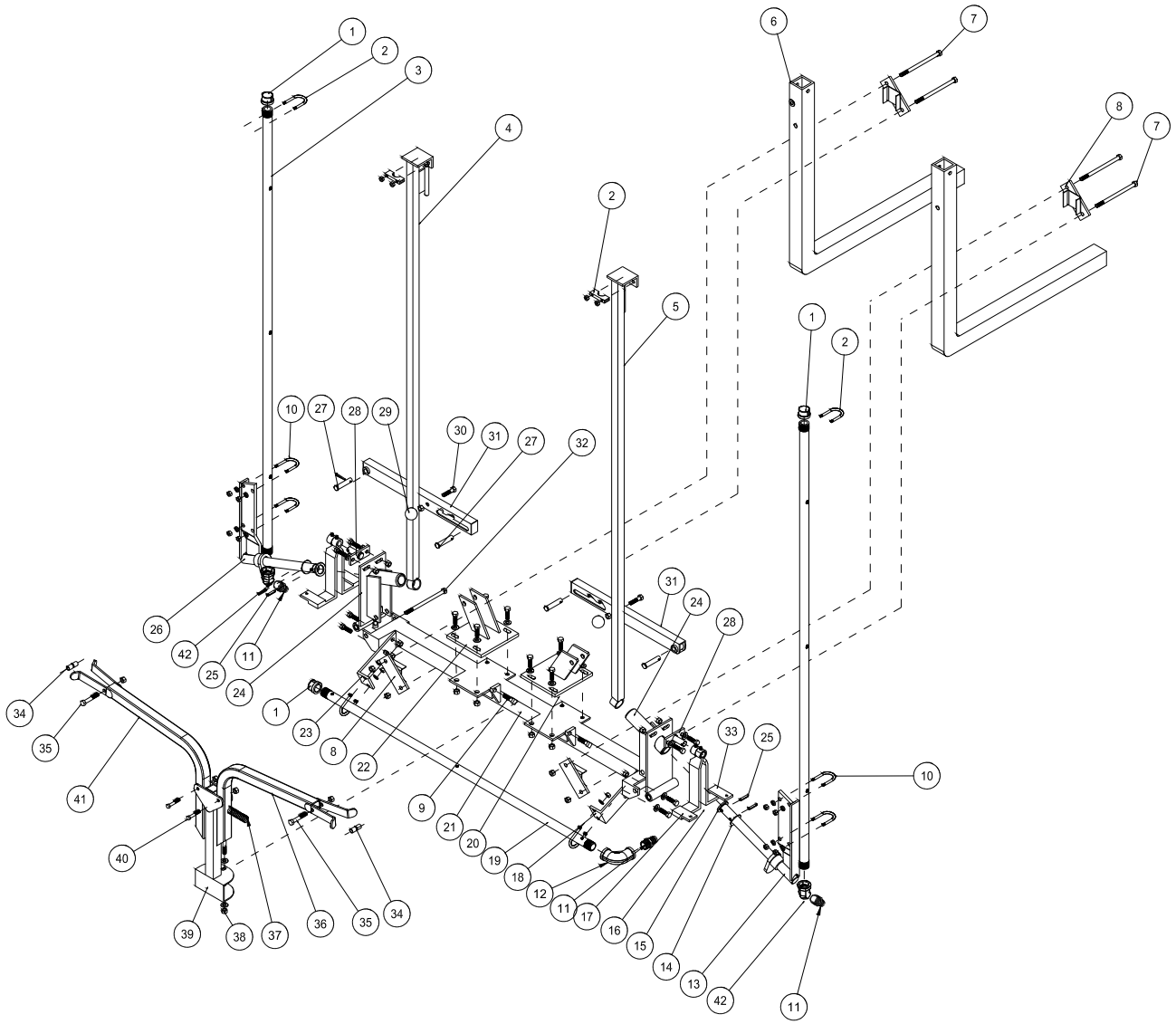

Accessories

10-160 STAINLESS STEEL 15' MANUAL BOOM PARTS LIST

REF#	PART#	DESCRIPTION	QUANTITY
1	16-926	Stainless Steel Cap $\frac{3}{4}$	3
2	13-498	U-Bolt Kit $1\frac{1}{8}$	2
3	15-562	Right and Left Boom Tube	2
4	15-565	Left Brush Guard	1
5	15-564	Right Brush Guard	1
6		Boom Carrier (part of the truck)	
7	HBS-38-16-550	Stainless Steel Bolt $\frac{3}{8}$ - 16 x $5\frac{1}{2}$	4
	HNTL-38-16	Lock Nut $\frac{3}{8}$ - 16	4
8	16-761	Boom Brackets	4
10	16-024	U-Bolt $\frac{5}{16}$ - 24	6
	HWS-516	Stainless Steel Washer $\frac{5}{16}$	12
	HNS-516-24	Stainless Steel Nut $\frac{5}{16}$ - 24	12
11	18-249	Barb Fitting	3
	18-040	Hose Clamp	3
12	16-925	Stainless Steel Pipe Elbow $\frac{3}{4}$ x 90°	1
13	33-301	Right Pivot Bracket	1
14	HMB-100-14	Machine Bushing 1 x 14GA	4
15	HMB-100-10	Machine Bushing 1 x 10GA	2
16	15-495	Extension Spring	2
17	15-812	Right Cam Stop (must also order 15-811)	2
	18-268	Oilite Bushing	2
18	33-308	Right, Center Tube Bracket	1
	HBS-38-16-125	Stainless Steel Bolt $\frac{3}{8}$ - 16 x $1\frac{1}{4}$	2
	HWS-38	Stainless Steel Washer $\frac{3}{8}$	2
	HNTL-38-16	Lock Nut $\frac{3}{8}$ - 16	2
19	16-927	Center Tube	1
20	33-330	Right Actuator Bracket	1
	HBS-38-16-125	Stainless Steel Bolt $\frac{3}{8}$ - 16 x $1\frac{1}{4}$	4
	HWS-38	Stainless Steel Washer $\frac{3}{8}$	4
	HNTL-38-16	Lock Nut $\frac{3}{8}$ - 16	4
21	33-329	Center Mount	1
A	HSSQS-38-16-150	Stainless Steel Set Screw $\frac{3}{8}$ - 16 x $1\frac{1}{2}$ (part of 33-329)	2
	HN-38-16	Nut $\frac{3}{8}$ - 16 (part of 33-329)	2
22	33-331	Left Actuator Bracket	1
	HB-38-16-125	Bolt $\frac{3}{8}$ - 16 x $1\frac{1}{4}$	4
	HW-38	Washer $\frac{3}{8}$	4
	HNTL-38-16	Lock Nut $\frac{3}{8}$ - 16	4
23	33-309	Left Center Tube Bracket	1
	HBS-38-16-125	Stainless Steel Bolt $\frac{3}{8}$ - 16 x $1\frac{1}{4}$	2
	HWS-38	Stainless Steel Washer $\frac{3}{8}$	2
	HNTL-38-16	Lock Nut $\frac{3}{8}$ - 16	2
24	15-813	Pivot Bracket	2
	15-494	Nylon Flange Bushing	4
	18-036	Oilite Bushing	4
B	HSSQS-38-16-150	Stainless Steel Set Screw $\frac{3}{8}$ - 16 x $1\frac{1}{2}$	2
	HN-38-16	Nut $\frac{3}{8}$ - 16	2
25	HRPS-14-150	Stainless Steel Roll Pin $\frac{1}{4}$ x $1\frac{1}{2}$	4
26	33-302	Left Pivot Bracket	1
27	HCPS-12-225	Stainless Steel Clevis Pin $\frac{1}{2}$ x $2\frac{1}{4}$	4
	HPS-18-100	Stainless Steel Cotter Pin $\frac{1}{8}$ x 1	4
28	15-810	Pivot	2
	HMB-58-14	Machine Bushing $\frac{5}{8}$ x 14GA	8
	HPS-18-100	Cotter Pin $\frac{1}{8}$ x 1	2
	HBS-38-16-125	Stainless Steel Bolt $\frac{3}{8}$ - 16 x $1\frac{1}{4}$	4
	HWS-38	Stainless Steel Washer $\frac{3}{8}$	4
	HNTL-38-16	Lock Nut $\frac{3}{8}$ - 16	4

(Continued on next page)



10-160 STAINLESS STEEL 15' MANUAL BOOM DRAWING (CONTINUED)

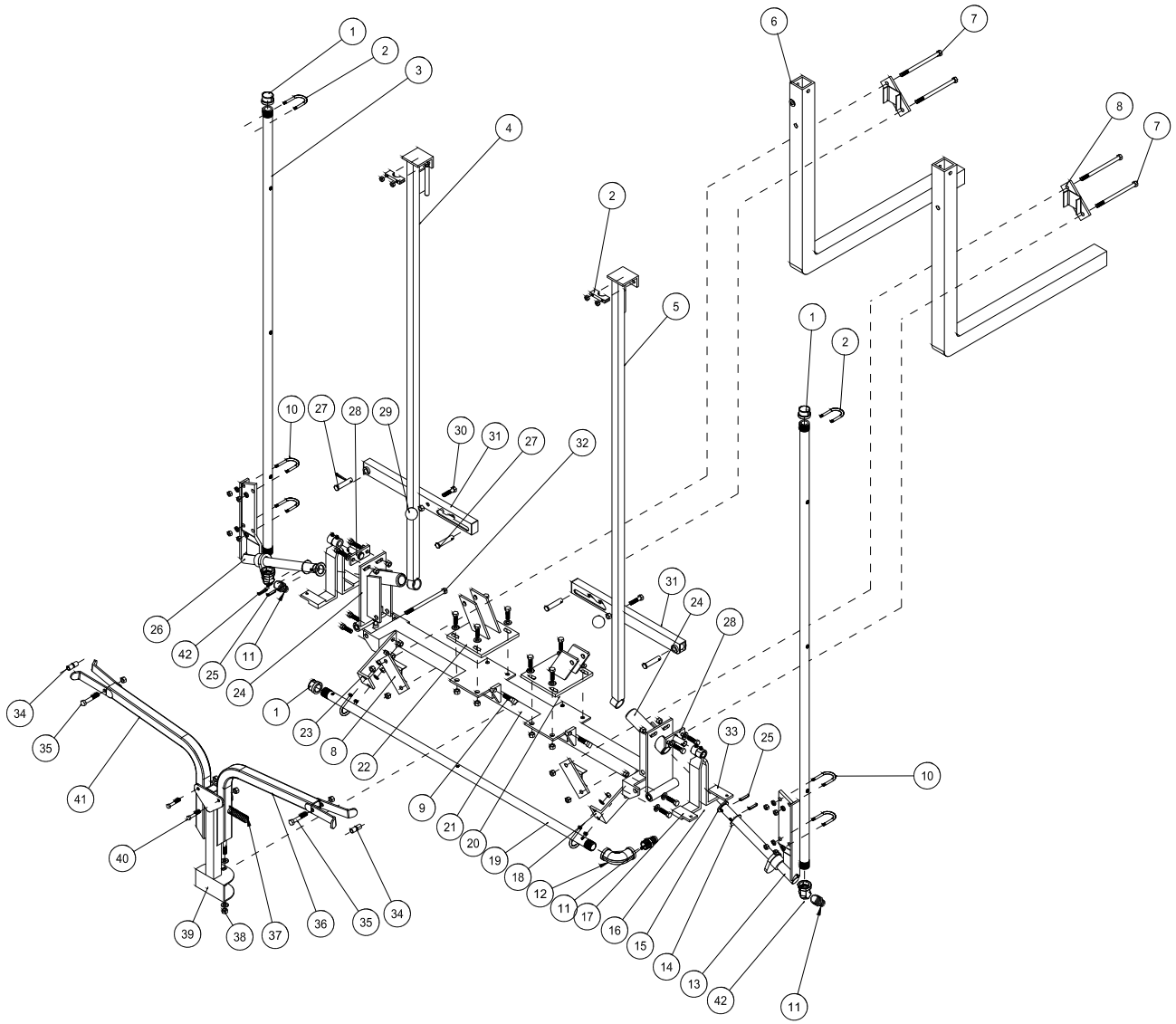

Accessories

10-160 STAINLESS STEEL 15' MANUAL BOOM PARTS LIST (CONTINUED)

REF#	PART#	DESCRIPTION	QUANTITY
29	15-014	Shift Knob	2
30	HB-38-16-175	Bolt $\frac{3}{8}$ - 16 x $1\frac{3}{4}$	2
	HN-38-16	Nut $\frac{3}{8}$ - 16	2
31	15-561	Boom Lift	2
32	HBS-12-13-550	Stainless Steel Bolt $\frac{1}{2}$ - 13 x $5\frac{1}{2}$	2
	HNCL-12-13	Center Lock Nut $\frac{1}{2}$ - 13	2
33	15-811	Left Cam Stop (must also order 15-812)	1
	18-268	Oilite Bushing	2
34	18-289	Bushing $\frac{3}{8}$ ID - $\frac{1}{2}$ OD x $\frac{5}{8}$	4
35	HB-38-16-225	Bolt $\frac{3}{8}$ - 16 x $2\frac{1}{4}$	2
	HNTL-38-16	Lock Nut $\frac{3}{8}$ - 16	2
36	10-247	Right Boom Stabilizer	1
	15-020	Hand Grip	2
37	21-212	Extension Spring	1
38	HB-38-16-300	Bolt $\frac{3}{8}$ - 16 x 3	1
	HW-38	Washer $\frac{3}{8}$	2
	HNTL-38-16	Lock Nut $\frac{3}{8}$ - 16	1
39	10-162	Boom Support	1
40	HB-516-18-225	Bolt $\frac{5}{16}$ - 18 x $2\frac{1}{4}$	2
	HNTL-516-18	Lock Nut $\frac{5}{16}$ - 18	2
41	10-246	Left Boom Stabilizer	1
	15-020	Hand Grip	2
42	18-411	Stainless Steel Pipe Elbow $\frac{3}{4}$ x 45°	2

For best result use Teflon® tape on all fittings.

- The three boom assemblies are not on the packing list but are in the carton. The long boom assemblies are the right and left booms. The labels are located on the pivot brackets (Ref 13 and 26). The small boom assembly is the center boom. You can NOT order these boom assemblies as one unit. Please refer to parts drawing for individual parts.
- Mount small boom assembly to the boom carriers on sprayer using four boom brackets (Ref 8), four bolts, $\frac{3}{8}$ - 16 x $5\frac{1}{2}$ and four lock nuts, $\frac{3}{8}$ - 16 (Ref 7). One boom bracket should go on boom assembly and one on boom carrier. Do the same for right and left side. Place boom at desired level (approximately 20" (51 cm) nozzle height) and center. Tighten bolts.
- Put the actuator brackets (Ref 20 and 22) on the center mount (Ref 21) using $\frac{3}{8}$ - 16 x $1\frac{1}{4}$ bolts, washers and lock nuts, with washers next to the slots. Snug up the bolts so that you can adjust actuator brackets with the set screws (Ref A) on the center mount after booms have been mounted.
- Take right boom and slide pivot bracket (Ref 24) in center mount (Ref 21) and hold in place with $\frac{1}{2}$ - 13 x $5\frac{1}{2}$ bolt and $\frac{1}{2}$ - 13 center lock nut (Ref 32). Do not over tighten, boom must be able to move up and down. Repeat for left boom.
- Install boom lifts (Ref 31) using clevis pin and cotter pin (Ref 27) so the bushing end hooks to the pivot bracket (Ref 24) and the slotted end hooks to the actuator bracket (Ref 20 and 22).
- Hook hoses to respective fittings using hose clamps (18-040). The hose coming from right side of sprayer goes to straight fitting on right boom. Center hose from sprayer goes to straight fitting on center boom. The left hose from sprayer goes to straight fitting on left boom. Be sure all clamps are tight.
- Use the adjustment slots on the boom lifts to completely lift and lower booms.
- Using set screws (Ref A) adjust actuator brackets so nozzles of booms are at same height with nozzles of center section. Tighten bolts holding actuator brackets to center mount and locknuts on set screws.
- Rubber boom carrier and latch are located on the horizontal boom support on top of tank.
- Put the viton gaskets (16-800), Raindrop tips (16-805) and quick TeeJet caps (16-921) on nozzle bodies (16-996) on the three boom sections.
- Make certain set screws (B) on both sides are completely screwed in and locked with the lock nut.

NOZZLE ASSEMBLY

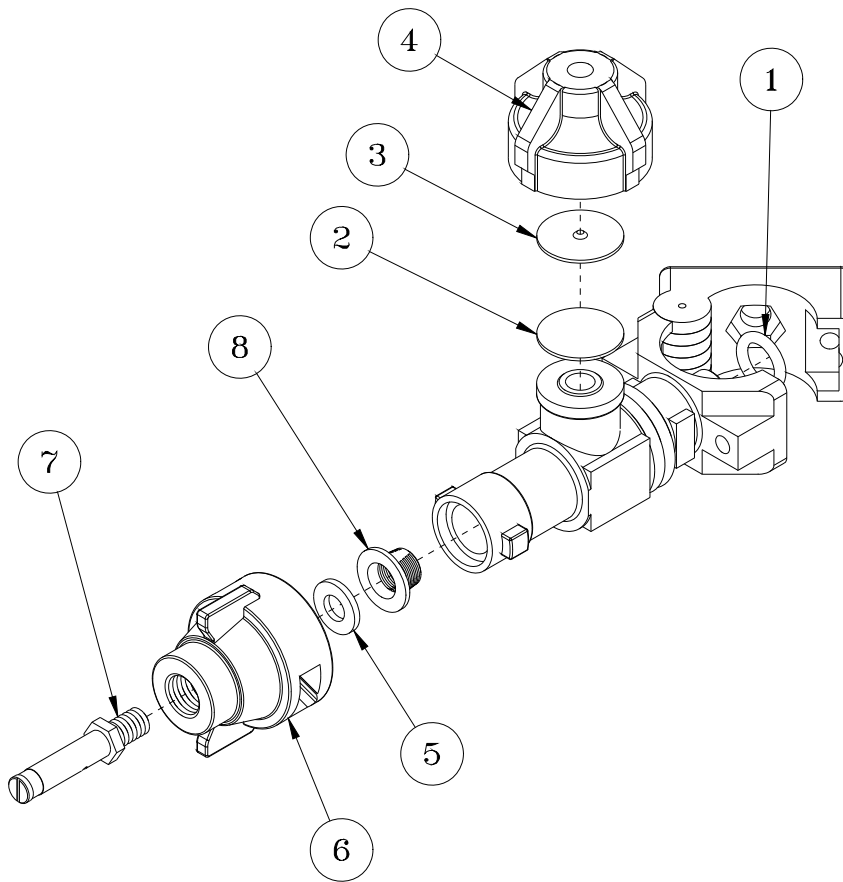

REF#	PART#	DESCRIPTION	QUANTITY
1*	16-920-03	O-Ring	1
2	16-920-05	Diaphragm Teflon (Optional)	1
3*	16-920-06	Diaphragm EPDM Rubber (Standard)	1
4*	16-798	Chemsaver End Cap	1
5	16-800	Gasket Viton	1
6	16-921	Cap	1
7	15-588	Turbo Turf Jet Tip #8	1
8	16-802	Strainer	1
*	16-996	Body	1

NOTE:

When the 16-920-05 Teflon Diaphragm is used, it is placed in the assembly in front of the 16-920-06 EPDM Rubber Diaphragm. Nozzles are located 20" (51 cm) apart on the right, left, and center tubes. There are predrilled holes in all tubes. The Nozzle should be at a 45° angle to the ground for proper application.

NOTE:

For all 18' Booms: The eleven 16-996 bodies are installed on the boom sections. The eleven 16-800 viton gasket, 16-802 strainer, 15-588 Turbo Turf Jet Tip #8 and 16-921 cap are in the small parts bag.

TURBO TURFJET TIPS

This is a wide-angle (110°), hollow-cone, drift-reduction nozzle. Replaces conventional flooding nozzles in broadcast applications.

FEATURES:

- Color-coding makes it easy to match nozzle flow rates for easy identification.
- Color-coding is available in sizes 1/4 TTJ02-VS through 1/4 TTJ15-VS.
- Uniform spray distribution.
- A large orifice opening and passages minimize clogging.
- The Turbo TurfJet nozzle's patented design element, a secondary swirl chamber in the nozzle cap, alters the swirling action of the liquid so that the fewer driftable lines are discharged from the secondary orifice.
- Spraying Pressure 25-75 PSI (1.5-5 bar).

NOZZLE TILT

Delavan's extensive research on spray patterns has proven that a tilt of about 45° for flood Nozzles or tips will significantly improve the spray pattern uniformity.

The nozzle tilt reduces the effect of boom height variation and allows the spray nozzle to maintain a more fully developed pattern even when the nozzle outlet is below the recommended height for the best spray pattern uniformity.

RECOMMENDED OVERLAP AND NOZZLE HEIGHT

Adjust spray height in the field to overlap a minimum of 30% of each edge of pattern. Adjust nozzle height until this is achieved. If a decision to tilt the nozzle is made, do it before measuring the width of the spray on the ground and adjusting nozzle height. See example below.

DRIFTABLE FINES PRODUCED

(0.5 gpm at 40 psi)

Nozzle (.5 gpm Output)	Percent of Spray Volume less than 200 microns
Turbo TurfJet	< 1%

XR TEEJET TIPS

This is an extended range flat spray tip. It is excellent for Contact Pesticides and Growth Regulators and good for Systemic Pesticides.

Contact Pesticides and Growth Regulators - At medium pressures (20-30 psi) provides medium size droplets for good surface coverage and less drift. At higher pressures (30-60 psi) produces smaller droplets for better coverage. Wide angle 110° tips produce slightly smaller droplets than 80° tips at equal pressures.

Systemic Pesticides - At lower pressures (15-20 psi) produces larger spray droplets and reduces drift while still providing uniform coverage along the boom.

FEATURES:

- Excellent spray distribution over a wide range of pressures (15-60 psi).
- Ideal for rigs equipped with sprayer controllers.
- Reduces drift at lower pressures, better coverage at higher pressures.
- Available in stainless steel and hardened stainless steel in 80° and 110° tip spray angles with VisiFlo color coding.

RECOMMENDED OVERLAP

Adjust nozzle spray height to overlap 30% of each edge of pattern.

NOZZLE HEIGHT

Suggested spray nozzle height with 20" spacing, tip spray angle of 80° should be 17-19", tip spray angle of 110° should be 12-14".

17-525 18' SMITHCO SUPER BOOM

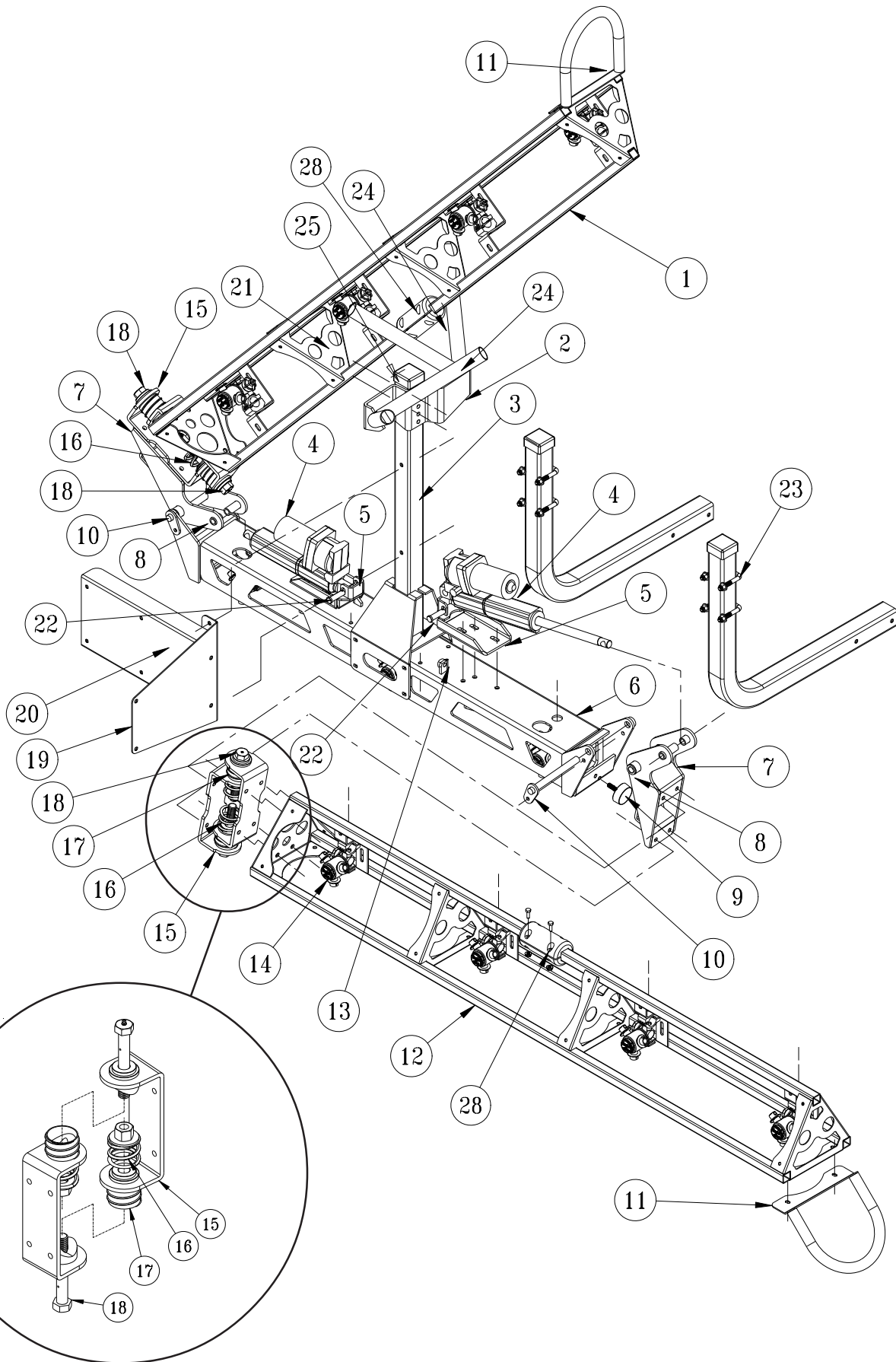

Accessories

REF#	PART#	DESCRIPTION	QUANTITY
1	17-531	Left Boom Arm	1
2	17-576	V Boom Nest	1
3	17-578	Boom Nest Post	1
	HBFL-516-18-075	Bolt, ⁵ / ₁₆ - 18 x ³ / ₄	4
	HNFL-516-18	Flange Lock Nut, ⁵ / ₁₆ - 18	4
4	17-553	8" Electric Hydraulic Actuator	2
5	17-545	Ram Mount	2
	HB-38-16-100	Bolt, ³ / ₈ - 16 x 1	6
	HW-516	Washer, ⁵ / ₁₆	6
	HNFL-38-16	Flange Lock Nut, ³ / ₈ - 16	6
6	17-528	Boom Center	1
7	17-529	Arm Pivot Hinge	2
	76-128	Bushing	4
8	HB-12-13-500	Bolt, ¹ / ₂ - 13 x 5	2
	HNTL-12-13	Lock Nut, ¹ / ₂ - 13	2
9	HB-38-16-250	Bolt, ³ / ₈ - 16 x 2 ¹ / ₂	2
	HNTL-38-16	Lock Nut, ³ / ₈ - 16	2
10	17-530	Hinge Pin	2
	HB-516-18-075	Bolt, ⁵ / ₁₆ - 18 x ³ / ₄	2
11	17-541	Boom End Guard	2
	HBFL-516-18-075	Bolt, ⁵ / ₁₆ - 18 x ³ / ₄	4
	HNFL-516-18	Flange Lock Nut, ⁵ / ₁₆ - 18	4
12	17-532	Right Boom Arm	1
13	HSSQS-38-16-150	Square Head Set SCrew , ³ / ₈ -16 x 1 ¹ / ₂	2
14	33-506	Body (see nozzle drawing)	11
	HB-516-18-075	Bolt, ⁵ / ₁₆ - 18 x ³ / ₄	11
	HNFL-516-18	Flange Lock Nut, ⁵ / ₁₆ - 18	11
15	17-527	Boom Hinge	4
	HB-38-16-100	Bolt, ³ / ₈ - 16 x 1	16
	HNFL-38-16	Lock Nut, ³ / ₈ - 16	16
16	17-539	Compression Spring	4
17	9026-2	Rubber Duct Hose x 2"	4
18	17-540	Tapped Bolt	4
	HW-34	Washer, ³ / ₄	4
	HNTL-34-10	Lock Nut, ³ / ₄ - 10	4
	HG-14-28-180	Grease Fitting, ¹ / ₄ - 28 x 180°	4
19	17-535	Clean Load Mount	1
20	HB-38-16-300	Bolt, ³ / ₈ - 16 x 3	2
	HNTL-38-16	Lock Nut, ³ / ₈ - 16	2
21	HB-38-16-300	Bolt, ³ / ₈ - 16 x 3	2
	HW-38	Washer, ³ / ₈	2
	HNTL-38-16	Lock Nut, ³ / ₈ - 16	2
22	HB-12-13-300	Bolt, ¹ / ₂ - 13 x 3	2
	HNTL-12-13	Lock Nut, ¹ / ₂ - 13	2
23	17-537	Square U-bolt with Nut	4
24	8897-12	Discharge Hose 1-1/4"	4
25	16-557	Rubber Cap	1
26	18-234	1" Bushing (part of 17-553)	2
27	18-036	¹ / ₂ " Bushing (part of 17-553)	2
28	17-573	Guide Block	2
	HB-14-20-125	Bolt ¹ / ₄ - 20 x 1 ¹ / ₄	8
	HNFL-14-20	Flange Lock Nut ¹ / ₄ - 20	8

17-550 15' SMITHCO SUPER BOOM

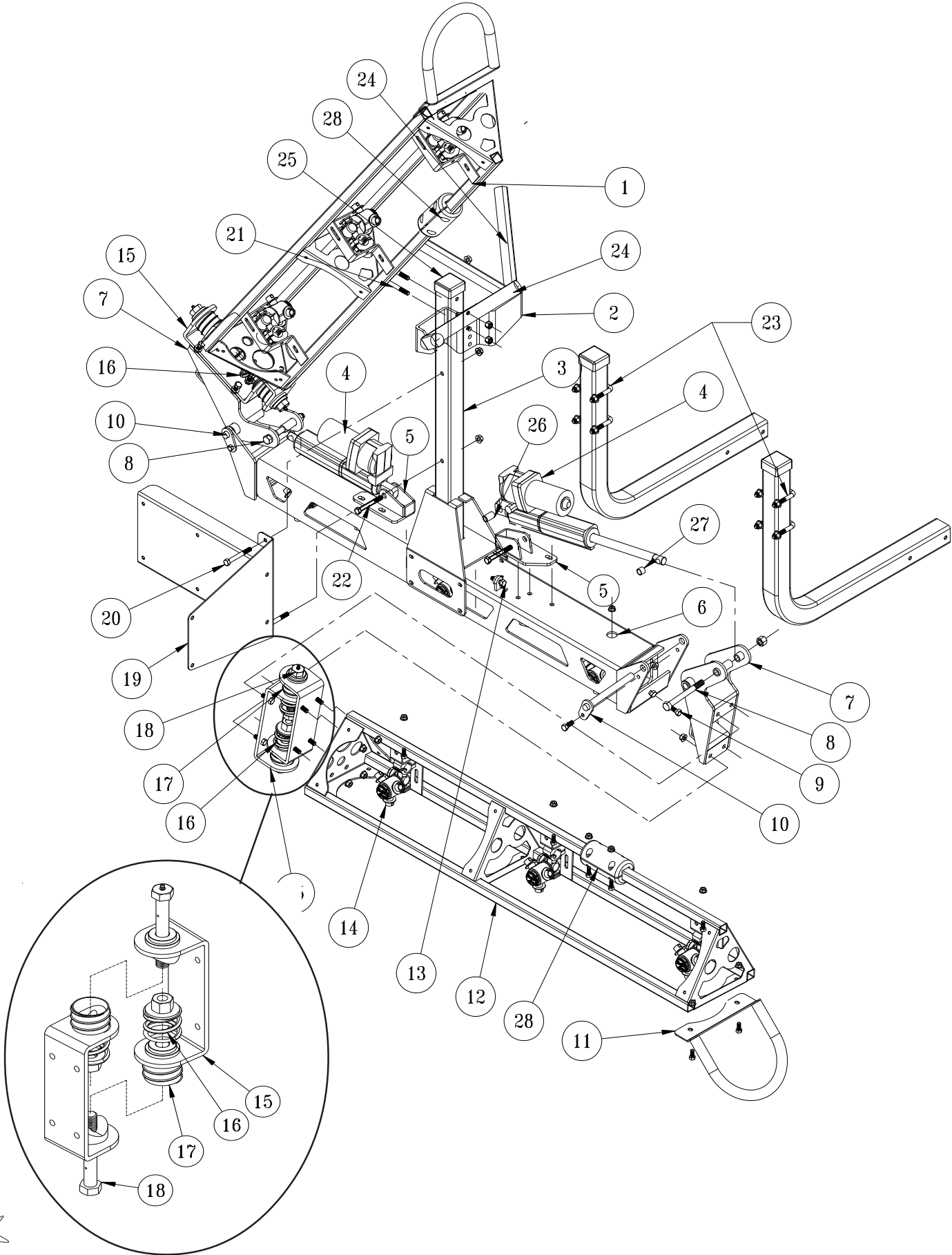

Accessories

REF#	PART#	DESCRIPTION	QUANTITY
1	17-551	Left Boom Arm	1
2	17-576	V-Boom Nest	1
3	17-578	Boom Nest post	1
	HBFL-516-18-075	Bolt, ⁵ / ₁₆ - 18 x ³ / ₄	4
	HNFL-516-18	Flange Lock Nut, ⁵ / ₁₆ - 18	4
4	17-553	8" Electric Hydraulic Actuator	2
5	17-545	Actuator Mount	2
	HB-38-16-100	Bolt, ³ / ₈ - 16 x 1	6
	HW-516	Washer, ⁵ / ₁₆	6
	HNFL-38-16	Flange Lock Nut, ³ / ₈ -16	6
6	17-528	Boom Center	1
7	17-529	Arm Pivot Hinge	2
	76-128	Bushing	4
8	HB-12-13-500	Bolt, ¹ / ₂ - 13 x 5	2
	HNTL-12-13	Lock Nut, ¹ / ₂ - 13	2
9	HB-38-16-250	Bolt, ³ / ₈ - 16 x 2 ¹ / ₂	2
	HNFL-38-16	Flange Lock Nut, ³ / ₈ -16	4
10	17-530	Hinge Pin	2
	HB-516-18-075	Bolt, ⁵ / ₁₆ - 18 x ³ / ₄	2
11	17-541	Boom End Guard	2
	HBFL-516-18-075	Bolt, ⁵ / ₁₆ - 18 x ³ / ₄	4
	HNFL-516-18	Flange Lock Nut, ⁵ / ₁₆ - 18	4
12	17-552	Right Boom Arm	1
13	HSSQS-38-16-150	Square Head Set Screw , ³ / ₈ -16 x 1 ¹ / ₂	2
14	33-506	Body (see nozzle drawing)	9
	HB-516-18-075	Bolt, ⁵ / ₁₆ -18 x ³ / ₄	9
	HNFL-516-18	Flange Lock Nut, ⁵ / ₁₆ -18	9
15	17-527	Boom Hinge	4
	HB-38-16-100	Bolt, ³ / ₈ - 16 x 1	16
	HNFL-38-16	Lock Nut, ³ / ₈ - 16	16
16	17-539	Compression Spring	4
17	9026-2	Rubber Duct Hose x 2"	4
18	17-540	Tapped Bolt	4
	HW-34	Washer, ³ / ₄	4
	HNTL-34-10	Lock Nut, ³ / ₄ -10	4
	HG-14-28-180	Grease Fitting, ¹ / ₄ - 28 x 180°	4
19	17-535	Clean Load Mount	1
20	HB-38-16-300	Bolt, ³ / ₈ - 16 x 3	2
	HNTL-38-16	Lock Nut, ³ / ₈ - 16	2
21	HB-38-16-300	Bolt, ³ / ₈ - 16 x 3	2
	HW-38	Washer, ³ / ₈	2
	HNTL-38-16	Lock Nut, ³ / ₈ - 16	2
22	HB-12-13-300	Bolt, ¹ / ₂ - 13 x 3	2
	HNTL-12-13	Lock Nut, ¹ / ₂ - 13	2
23	17-537	Square U-bolt with Nut	4
24	8897-12	1 ¹ / ₄ Discharge Hose 12"	4
25	16-557	Square Rubber Cap	1
26	18-036	1" Bushing (part of 15-553)	2
27	18-234	¹ / ₂ " Bushing (part of 15-553)	2
28	17-573	Guide Block	2
	HB-14-20-125	Bol ¹ / ₄ -20 x 1 ¹ / ₄	8
	HNFL-14-20	Lock Nut ¹ / ₄ - 20	8

TRIPLE NOZZLE ASSEMBLY

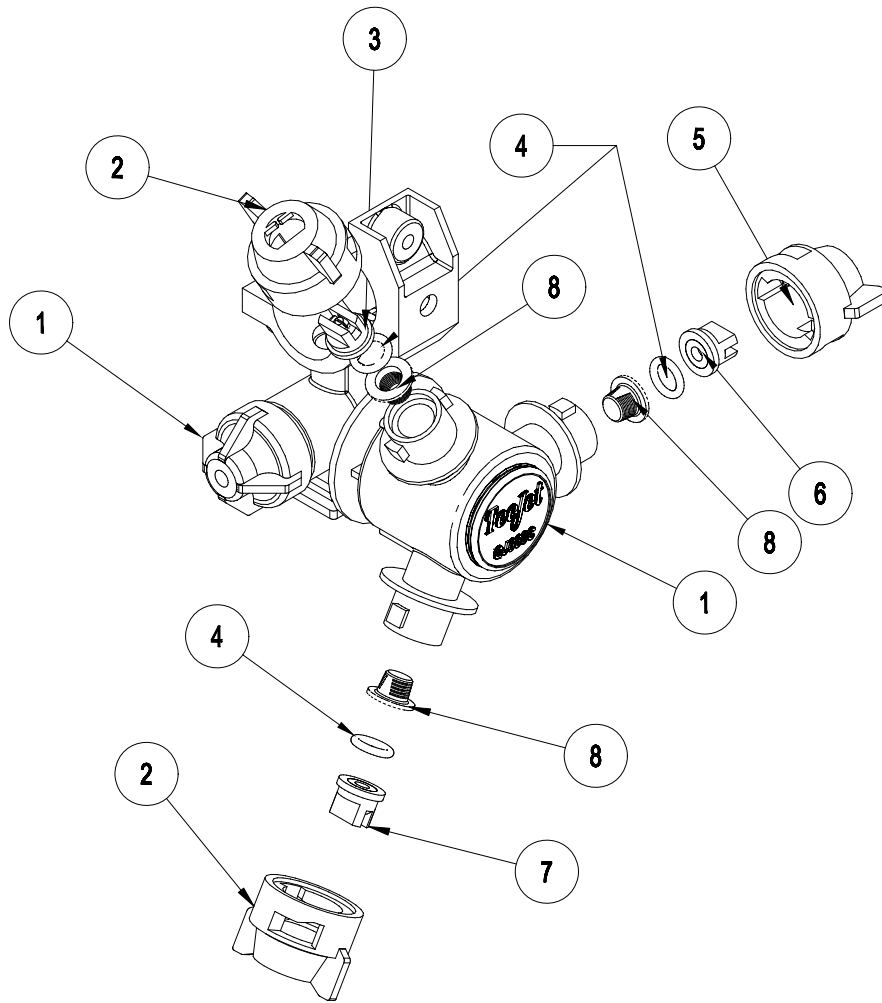

REF#	PART#	DESCRIPTION	QUANTITY
1	33-506	Body	1
2	33-538	Cap - Gray	2
3	33-553	Nozzle -Gray (XR11006-VS)	1
4	16-800	Viton Gasket	3
5	33-537	Cap - Red	1
6	33-552	Nozzle - Red (XR11004-VS)	1
7	33-554	Nozzle - White (XR11008-VS)	1
8	16-802	Strainer	3

Quantity is per nozzle body. For 18' booms multiply quantity by 11.

Quantity is per nozzle body. For 15' booms multiply quantity by 9.

Nozzles are located 20" (51 cm) apart on the right, left, and center tubes. There are predrilled holes in all tubes. The Nozzle should be at a 45° angle to the ground for proper application.

For re-ordering Nozzle Kits the following numbers apply

33-540 Triple Nozzle Kit for 18' Booms

33-541 Triple Nozzle Kit for 15' Booms

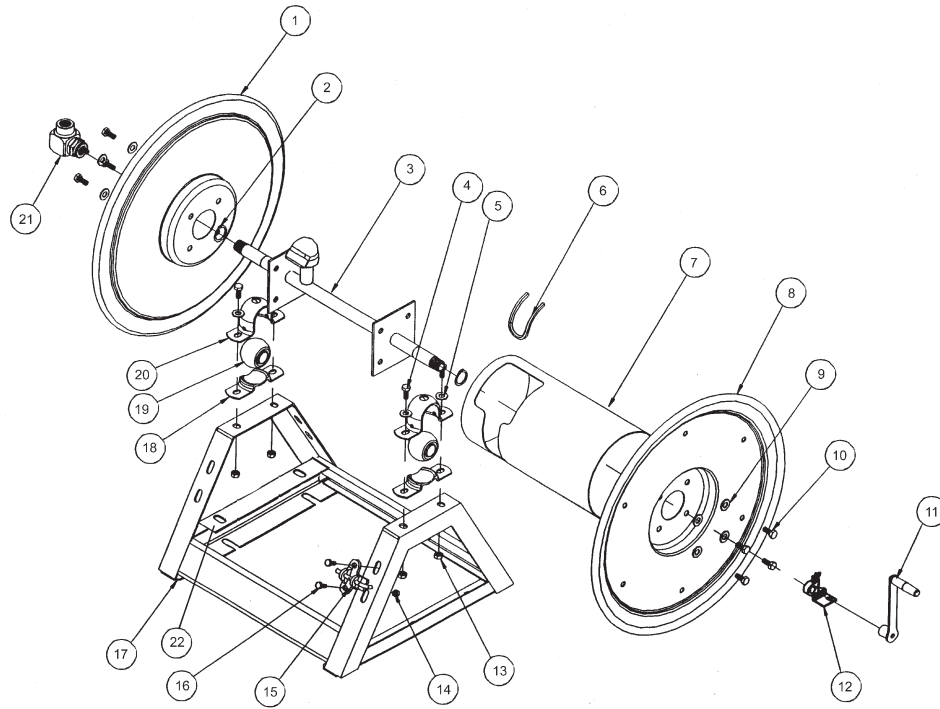

REF#	PART#	DESCRIPTION	QUANTITY
1	16-129-11	Disc 17 ¹ / ₂	1
2	16-906-25	Retaining Ring	2
3	16-906-22	Axle Assembly ³ / ₄	1
4	HB-38-16-100	Bolt ³ / ₈ - 16 x 1	4
5	HW-38	Washer ³ / ₈	4
6	16-906-27	Trim, Drum Edge	1
7	16-906-21	Drum Center	1
8	16-906-20	Disc 17 ¹ / ₂ , Crank Side	1
9	HWL-516	Lockwasher ⁵ / ₁₆	8
10	HB-516-18-075	Bolt ⁵ / ₁₆ - 18 x ³ / ₄	8
11	16-129-09	Crank Assembly ³ / ₄	1
12	16-129-10	Brake Assembly ³ / ₄	1
13	HNTL-38-16	Lock Nut ³ / ₈ - 16	4
14	HNTL-516-18	Lock Nut ⁵ / ₁₆ - 18	2
15	16-129-08	Lock Pin Assembly	1
16	HB-516-18-075	Bolt ⁵ / ₁₆ - 18 x ³ / ₄	2
	HW-516	Washer ⁵ / ₁₆	2
17	16-129-07	Frame Assembly	1
18	16-906-08	Mounting Pillow Block (Bottom)	2
19	16-906-24	Bearing	2
20	16-906-07	Mounting Pillow Block (Top)	2
21	16-906-23	Swivel Assembly ³ / ₄	1
	16-906-30	Seal Kit (For 16-906-23)	1
22	16-980	Mount Bracket	2
	HB-516-18-175	Bolt ⁵ / ₁₆ - 18 x 1 ³ / ₄	4
	HW-516	Washer ⁵ / ₁₆	4
	HNTL-516-18	Lock Nut ⁵ / ₁₆ - 18	4

16-906 ELECTRIC HOSE REEL

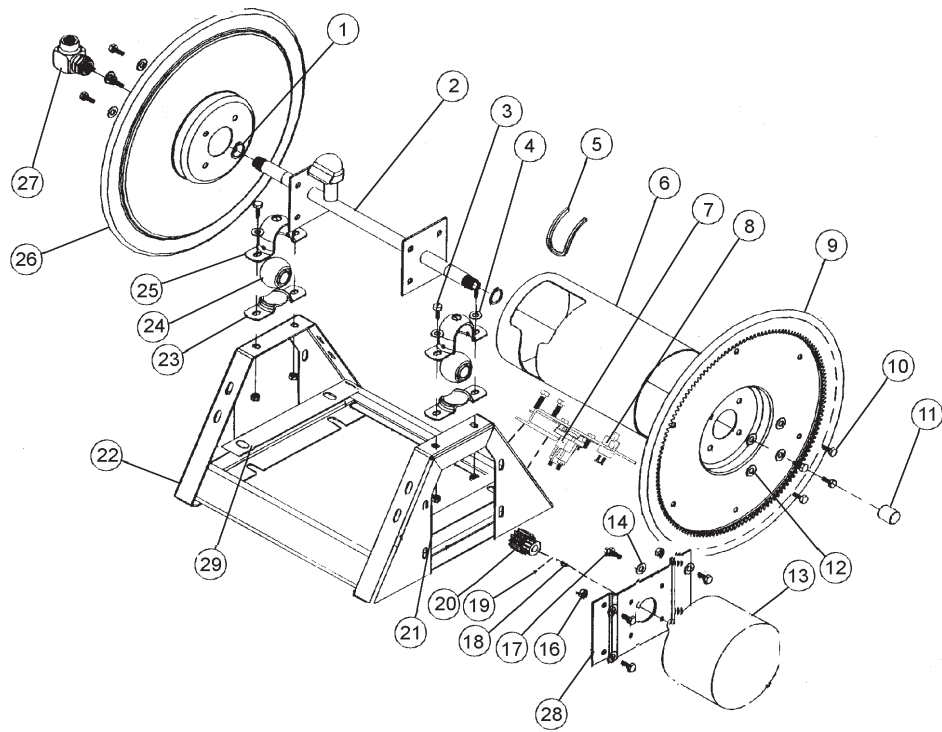

Accessories

16-906 ELECTRIC HOSE REEL

REF#	PART#	DESCRIPTION	QUANTITY
1	16-906-25	Retaining Ring	2
2	16-906-22	Axle Assembly	1
3	HB-38-16-100	Bolt $\frac{3}{8}$ - 16 x 1	4
4	HW-38	Washer $\frac{3}{8}$	4
5	16-906-27	Trim, Drum Edge	1
6	16-906-21	Drum Center	1
7	13-750	Solenoid	1
	HB-14-20-075	Bolt $\frac{1}{4}$ - 20 x $\frac{3}{4}$	2
	HWL-14	Lockwasher $\frac{1}{4}$	2
	HN-14-20	Nut $\frac{1}{4}$ - 20	2
8	33-251	Switch	1
9	16-906-19	Disc and Gear Assembly	1
10	HB-516-18-075	Bolt $\frac{5}{16}$ - 18 x $\frac{3}{4}$	8
11	16-906-26	Pipe Cap $\frac{3}{4}$	1
12	HWL-516	Lockwasher $\frac{5}{16}$	8
13		Motor 12VDC	1
14	HW-516	Washer $\frac{5}{16}$	4
15	33-252	Switch and Solenoid Brkt	1
	HB-516-18-075	Bolt $\frac{5}{16}$ - 18 x $\frac{3}{4}$	2
	HW-516	Washer $\frac{5}{16}$	2
	HWL-516	Lockwasher $\frac{5}{16}$	2
	HN-516-18	Nut $\frac{5}{16}$ - 18	2
16	HNTL-516-18	Lock Nut $\frac{5}{16}$ - 18	4
17	HB-516-18-100	Bolt $\frac{5}{16}$ -18 x 1	4
18	16-906-17	Key	1
19		Set Screw	2
20	16-906-29	Pinion	1
21	HNTL-38-16	Lock Nut $\frac{3}{8}$ - 16	4
22	16-906-18	Frame Assembly	1
23	16-906-08	Mounting Pillow Block (Bottom)	2
24	16-906-24	Bearing	2
25	16-906-07	Mounting Pillow Block (Top)	2
26	16-906-20	Disc 17 $\frac{1}{2}$	1
27	16-906-23	Swivel Assembly $\frac{3}{4}$	1
	16-906-30	Seal Kit (For 16-906-23)	1
28	16-906-28	Bracket 12VDC	1
29	16-980	Mount Bracket	2
	HB-516-18-175	Bolt $\frac{5}{16}$ - 18 x 1 $\frac{3}{4}$	4
	HW-516	Washer $\frac{5}{16}$	4
	HNTL-516-18	Lock Nut $\frac{5}{16}$ - 18	4
	16-982	Electric Hose Reel (only)	1

ELECTRIC HOSE REEL WIRING

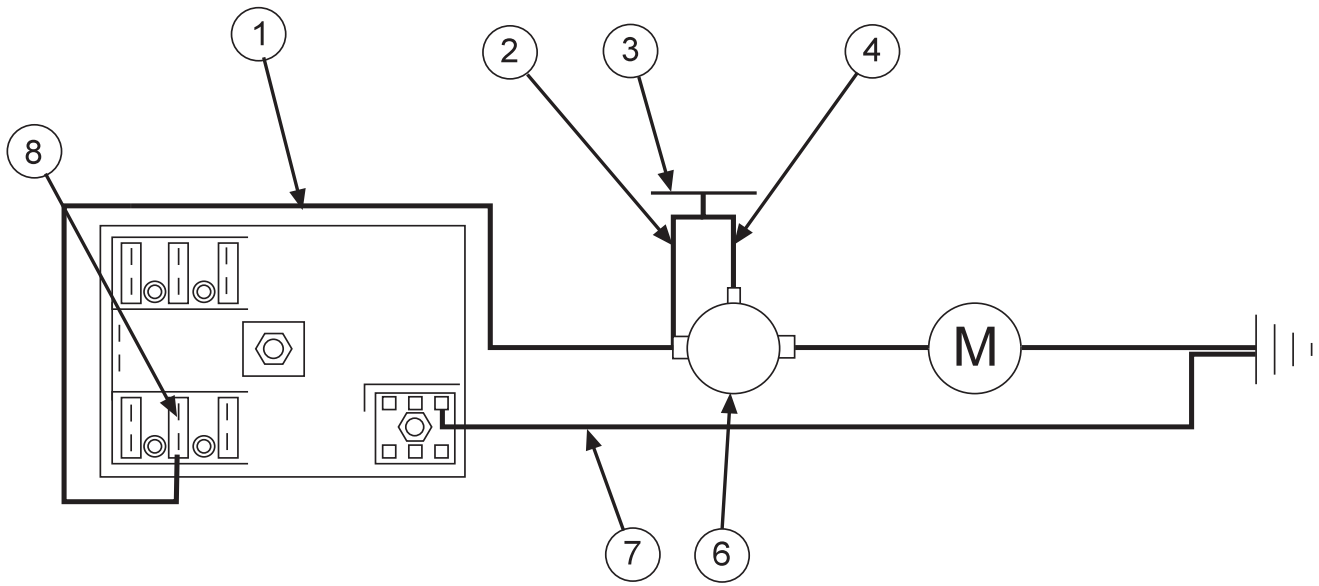

REF#	PART#	DESCRIPTION	QUANTITY
	8843-132	Flexguard 3/8 ID	1
1	8919-144	10GA Red Wire 144"	1
	8901	Slide-On Connector	1
2	16-979	Wire, Switch to Solenoid Hot Terminal	1
3	33-251	Push Button Switch	1
4	16-978	Wire, Switch to Solenoid Start Terminal	1
6	13-750	Solenoid	1
SOLENOID TERMINALS			
	HN -516-24	5/16 - 24 Hex Nut	2
	HN -10-32	10 - 32 Hex Nut	1
7	8931-144	10GA White Wire 144"	1
	8901	Slide-On Connector	1
8	33-273	Auto Blade Type Fuse 30Amp	1

CONNECTION INSTRUCTIONS

Route wire harness along side of tank and over to fuse block taking care to stay clear of moving parts or hot engine components. Cut off excess wire and strip back 3/8". Place one 8963 heat shrink (1/4 x 1 1/4) on each wire before crimping 8901 slide on connectors to the red and white wires. Connect the two wires to the fuse block first the red to the (+) positive and the white to the (-) negative. Put the 33-273 auto blade type fuse (30 amp) into fuse block.



Make certain you are connecting positive (+) to positive; negative (-) to negative while attaching power leads. If you do not observe polarity, damage will result to electrical components.

Accessories

Use Dielectric Grease On All Electrical Connections

OPERATIONAL CHECK:

1. Pull hose off drum at least one full revolution. A clicking noise should be heard from locking mechanism.
2. Let the hose retract.
3. Pull the hose off until the first click is heard. Drum should lock when the hose tension is removed.
4. Continue pulling the hose, no more than one revolution, until no clicking is heard. Hose should rewind when tension is removed.

HOSE REPLACEMENT PROCEDURE:

1. Facing swivel, turn the hose drum clockwise until all of the hose is removed from the drum and the drum is held by locking mechanism. Make sure spring is locked.
2. Remove hose clamps and disconnect hose from swivel. Remove old hose.
3. Insert new hose through roller guide, connect to swivel and reinstall hose clamps. Use spring guard over hose to protect the hose from being cut by the drum.
4. Remove check ball from old hose and install on replacement hose.
5. Carefully, keeping the tension on the hose, pull the hose to release the locking mechanism. Let the hose wind on the drum.

14-308 HOSE REEL MOUNT FOR 17-525/17-550 BOOMS

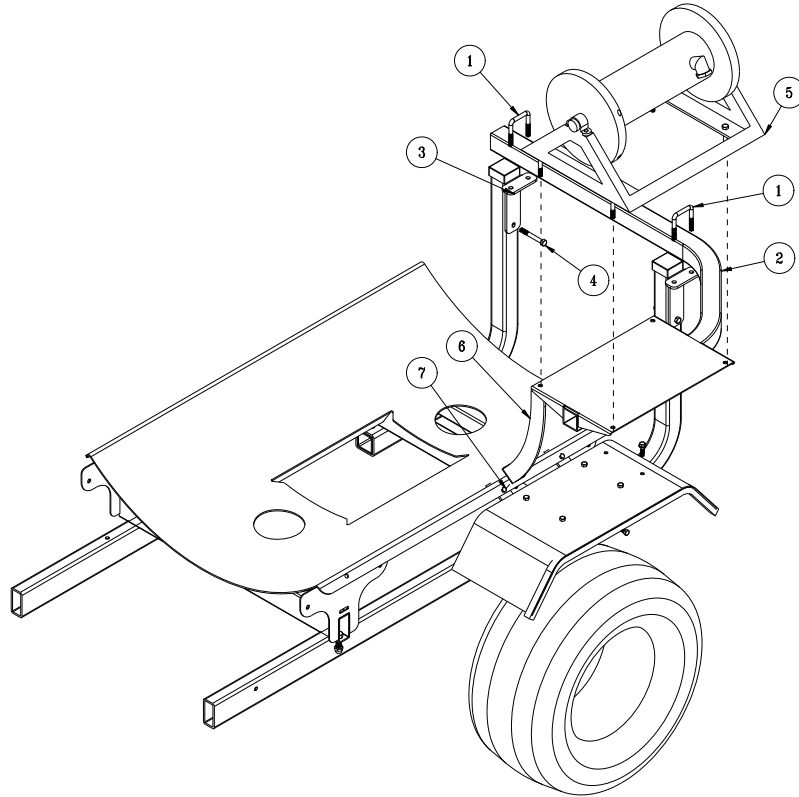

REF#	PART#	DESCRIPTION	QUANTITY
1	17-537	Square U-bolts	2
2	15-841	Reel Platform	1
3	15-840	Mount Brackets	2
4	HB-38-16-300	Bolt $\frac{3}{8}$ - 16 x 3	4
	HNTL-38-16	Lock Nut $\frac{3}{8}$ - 16	4
	HW-38	Waher $\frac{3}{8}$	4
5	16-906	Electric Hose Reel	1
	16-129	Manual Hose Reel	1
	18-249	Brass Fitting $\frac{3}{4}$ MPT x $\frac{3}{4}$ HB	1
6	14-542	Support Bracket	1
7	HB-1420-100	Bolt $\frac{1}{4}$ - 20 x 1	1
9	16-151	Elbow F.P.T. $\frac{3}{4}$ x $\frac{3}{4}$	1
10	16-859	Ball Valve $\frac{3}{4}$ Brass	1
11	16-154	Fitting $\frac{3}{4}$ MPT x $\frac{3}{4}$ HB	1
12	8887-90	Orange PVC Hose $\frac{3}{4}$	1
	18-040	Hose Clamp	2
13	18-260	Bushing $1\frac{1}{4}$ x $\frac{3}{4}$	1
14	18-073	Pipe Nipple $\frac{3}{4}$	1
15	16-158	Close Nipple $\frac{3}{4}$	2
16	16-157	UNion Tee	1

HOSE REEL PLUMBING

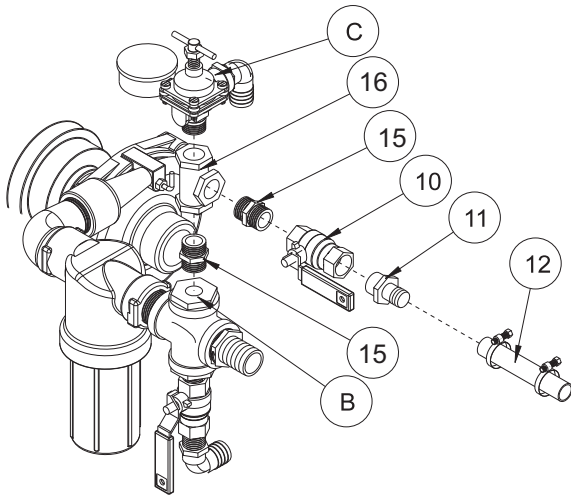

Figure 1
1602

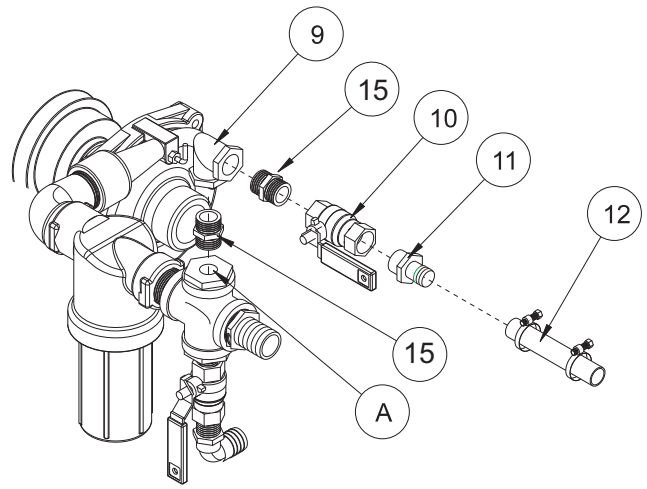

Figure 2
1604

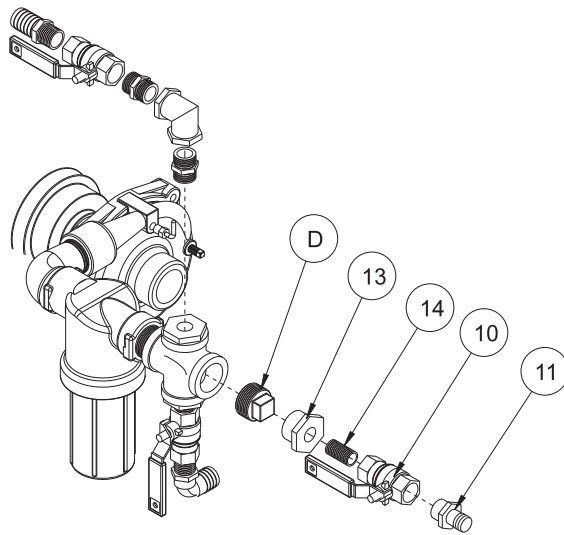
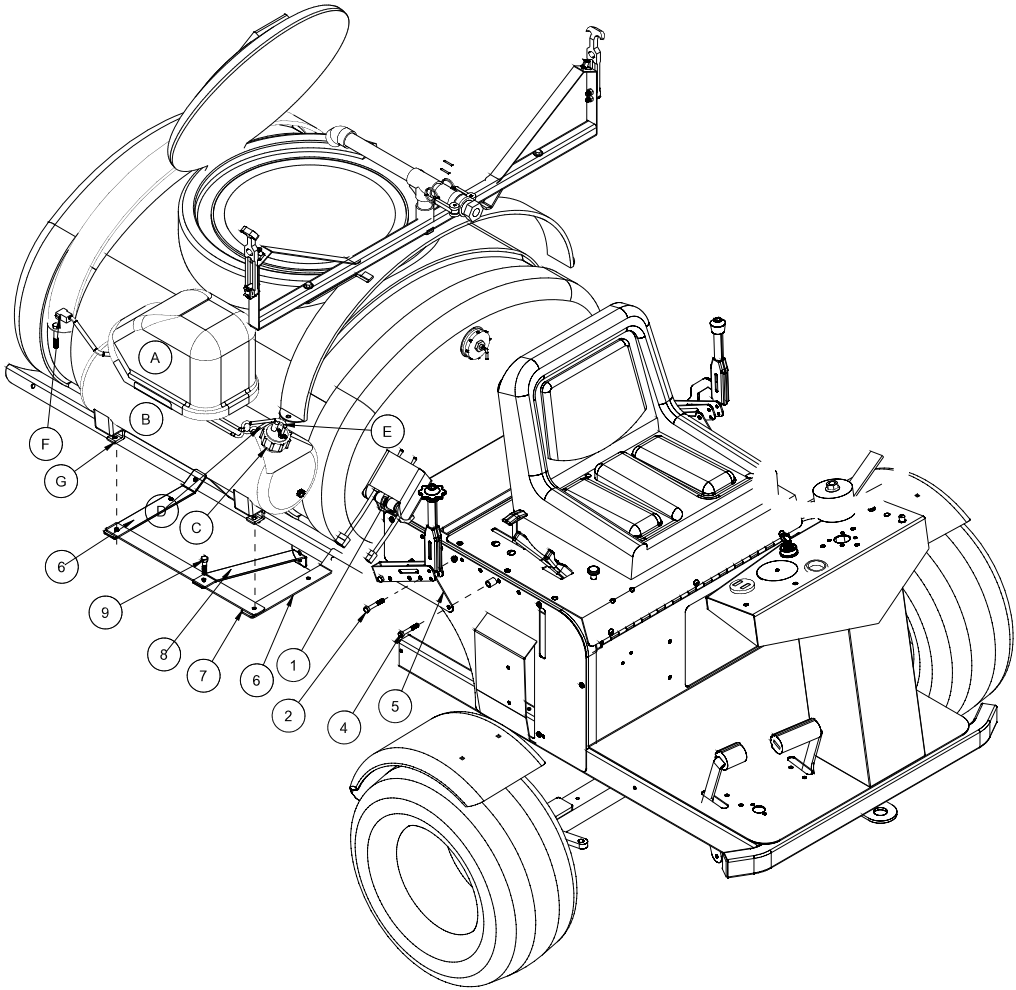

Figure 3
1610

14-283 FOAM MARKER FOR 1600P



Accessories

WIRING

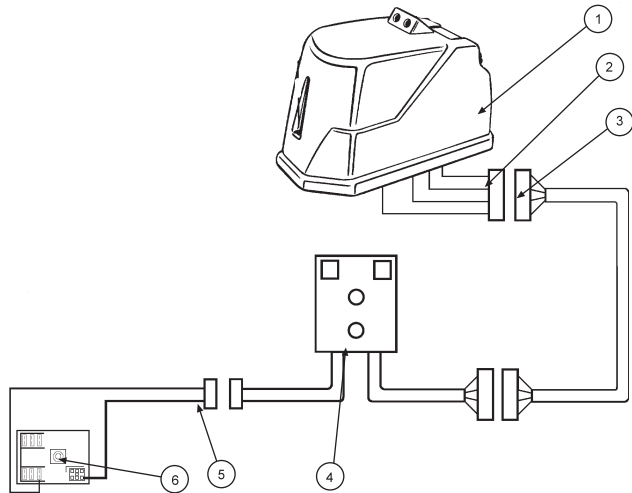

14-283 FOAM MARKER FOR 1600P

REF#	PART#	DESCRIPTION	QUANTITY
1*	14-291-05	Double Switch Box	1
	33-508	Fuse	1
	14-291-14	Outside Switch	1
	15-506-02	Center Switch	1
2	HB-516-18-175	Bolt ⁵ / ₁₆ - 18 x 1 ³ / ₄ (part of machine)	1
	HNTL-516-18	Lock Nut ⁵ / ₁₆ - 18 (part of machine)	1
4	HB-516-18-400	Bolt ⁵ / ₁₆ - 18 x 4 (part of machine)	1
	HNCL-516-18	Center Lock Nut ⁵ / ₁₆ - 18 (part of machine)	1
5	14-393	Park Brake Bracket (part of machine)	1
6	14-286	Foamer End Bracket	2
7	14-288	Foamer Cross Bar	1
8	14-287	Foamer Center Bracket	1
9	HB-516-18-100	Bolt ⁵ / ₁₆ - 18 x 1	8
	HNFL-516-18	Flange Whiz Lock Nut ⁵ / ₁₆ - 18	8
A*	14-291-03	Compressor Only	1
	14-291-01	Black Cover	1
B*	14-291-02	Foamer Tank	1
C*	14-284-02	Cap Assembly	1
D*		Blue Tube	1
E*		Clear Tube	1
F*	10-222	Extension Wire	1
G*	14-291-04	Tank Bracket	2
*	14-291	Foamer	1

FOAM MARKER WIRING

REF#	PART#	DESCRIPTION	QUANTITY
1	14-291-03	Compressor	1
2	15-504-04	Wiring Harness	1
3	10-222	Extension Wire	1
4	14-291-05	Switch Box	1
	33-508	Fuse	1
	15-506-02	Center Switch	1
	14-291-14	Outside Switch	1
5	15-509	Power Cable	1
6	33-271	Fuse Block (part of machine)	1
	33-508	Fuse	1

14-283 FOAM MARKER FOR 1600

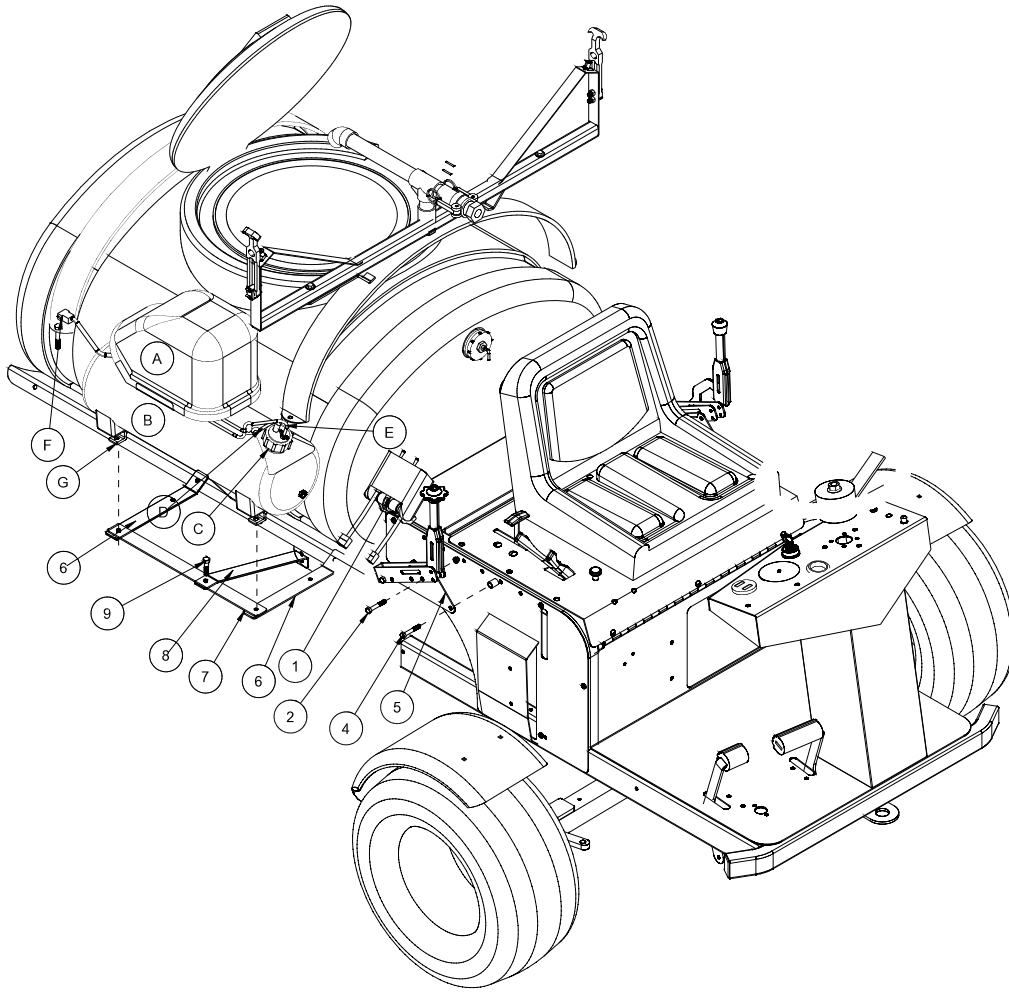

Accessories

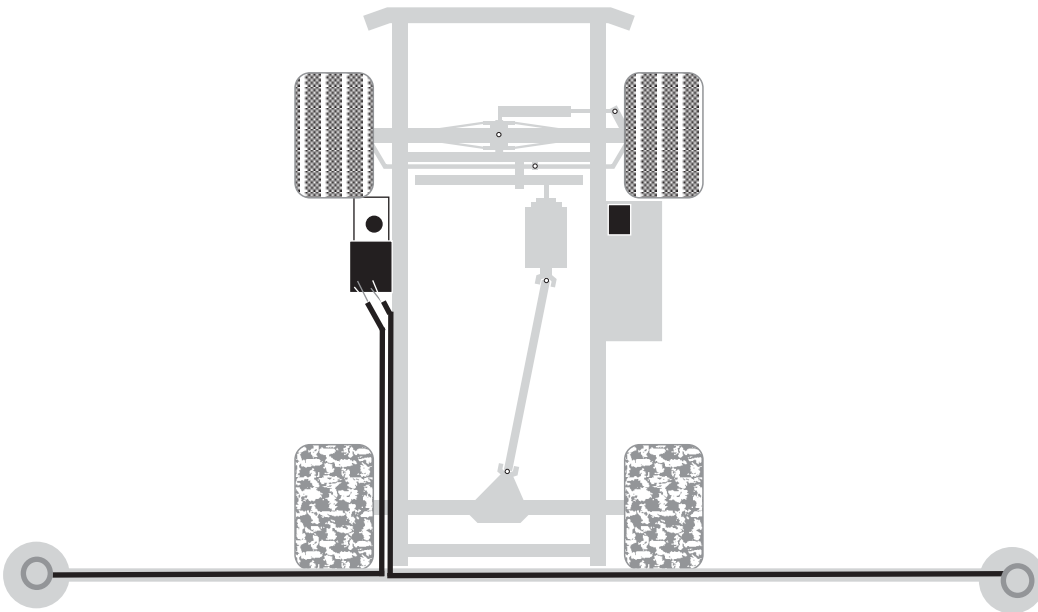

Safety: Before working on machine stop engine, set park brake, remove key from ignition and block wheels. Disconnect negative (-) battery terminal.

1. Mount the switch box (Ref 1) behind the seat on the rear engine cover.
2. Use the extension wire (10-222) to connect the compressor to the switch box.
3. Mount the two foamer end brackets (Ref G) to the tank brackets (Ref 6) in the first and third holes on the right side. Use two $\frac{5}{16}$ - 18 x 1 bolts and flange whiz lock nuts.
4. Mount the foamer center bracket (Ref 8) to the slot on the tank carrier support leg.
5. Put the cross bar (Ref 7) across the ends of the end and center brackets. Bolt center brackets to cross bar using two $\frac{5}{16}$ - 18 x 1 bolts and flange whiz lock nuts(Ref 9).
6. Place foamer assembly on the foamer end brackets and bolt in place with four $\frac{5}{16}$ - 18 x 1 bolts and flange whiz lock nuts.
7. Make sure all bolts are tightened.

WIRING

Use dielectric grease on all electrical connections. Connect extension wire to the pig tail on the switch box and compressor. Connect power cable (15-509) to the switch box. Turn the switch off. Route the power wire to the fuse block (on the inside of the engine cover) out of the way of any heat or moving parts. Use nylon ties as needed. Cut the power wire with enough length to connect the fuse block. Put the slide on terminal with heat shrink onto the wire ends and connect to fuse block. Red to positive(+), black to negative(-). Insert 10 amp fuse into slot which has red wire attached to it.

CONNECTING THE CAP ASSEMBLY

Connect the blue tube to the tank cap connector which is also connected to the large blue tube which hangs below the cap. This is the soap outlet tube. Connect the clear tube to the other connector on the tank cap. This is the air input tube. Tighten connectors hand tight, assembly tank cap onto tank.

HOSES

Being careful not to cut the tubing, cut the oversleeve back approximately 2" (5 cm) to expose blue and clear tubing. Remove blue wing nut from top connector of foam nozzle and slide it on the blue tube with the threads facing toward end of tube. Slide blue tube all the way over the top of the small tube on foam nozzle. Slide wing nut back to the threads and hand tighten. Follow the same steps for the clear tube and tube nut.

Route the tubing along underside of main frame using tie downs as necessary.

Install opposite ends of air-liquid tubes to compressor, again cutting back the oversleeve approximately 2" (5 cm) and inserting blue and clear tubes for the left boom section into the tubing connectors on the right side of compressor as far as possible. Follow the same steps for the right boom tubing. Notice the right boom is inserted into left side of compressor. To release tubing from compressor, hold black ring around tubing, and pull tube out.



FOAMER NOZZLE MOUNT & HOSE GUARD MOUNT

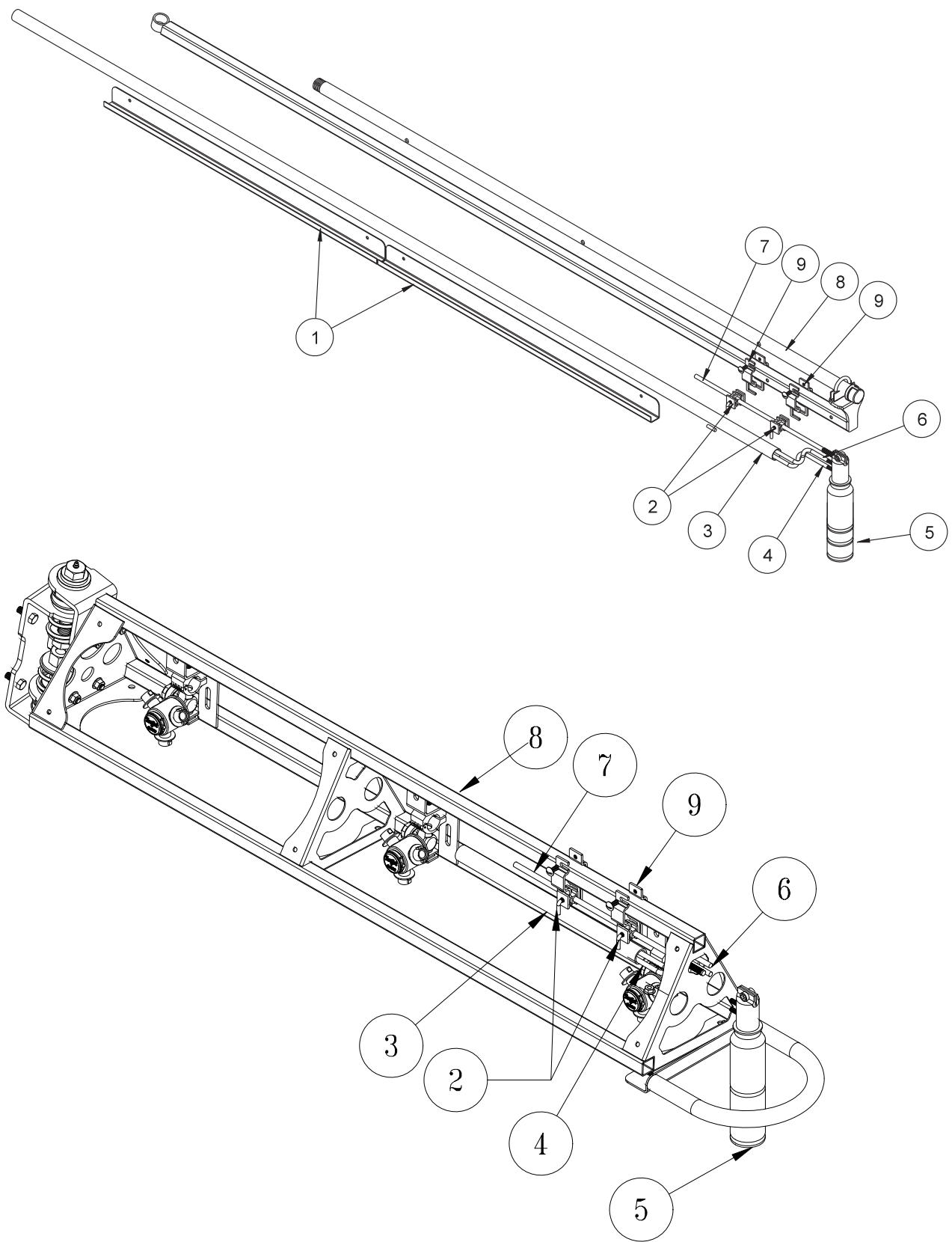

Accessories

REF#	PART#	DESCRIPTION	QUANTITY
1	15-537	Foamer Hose Guard 31"	2
	10-256	Foamer Hose Guard 16"	2
	HSDPS-14-075	Stainless Steel Pan Head Drill Screw $\frac{1}{4} \times \frac{3}{4}$	8
2	16-987	Foam Nozzle Mounting Kit	1 per boom
3	15-507	Foamer Tubing	1
4		Clear Tubing	
5	15-511	Foam Nozzle	2
6		Blue Tubing	
7	15-510-01	Nozzle Mounting Rod	2
8		Boom	
9	16-795	Square Clamp	4

- Slide hose clamp onto drop tube of foam nozzle and attach restrictor bell.
- Place splined end of Nozzle mounting rod (Ref 7) into top of foam nozzle (Ref 5). Tighten screw.
- Slide two foam nozzle mounts (Ref 2) onto the rod. Place square clamps (Ref 9) on foam nozzle mounts and mount the square clamps to the boom (Ref 8). Adjust foam nozzle mounts and clamps so nozzle assembly will clear end of boom. Tighten foam nozzle mounts and square clamps to prevent side to side movement. Do the same to the other side.
- Being careful not to cut the tubing (Ref 3), cut the oversleeve back approximately 2" (5 cm) to expose blue (Ref 6) and clear tubing (Ref 4).
- Remove blue wing nut from top connector of foam nozzle and slide it on the blue tube with the threads facing toward end of tube. Slide blue tube all the way over the top of the small tube on foam nozzle. Slide wing nut back to the threads and hand tighten. Follow the same steps for the clear tube and tube nut.
- Route the tubing along underside of main frame using tie downs as necessary.
- Install opposite ends of air-liquid tubes to compressor, again cutting back the oversleeve approximately 2" (5 cm) and inserting blue and clear tubes for the left boom section into the tubing connectors (Ref A) on the right side of compressor as far as possible.
- Follow the same steps for the right boom tubing. Notice the right boom is inserted into left side of compressor. To release tubing from compressor, hold black ring around tubing, and pull tube out.
- Hose's must be routed on bottom of the boom square tubing.
- Mark 6 inches in from inside edge of foamer nozzle mounting bracket on square boom tubing.
- Place hose guard (Ref 1) flush with top of square tubing with edge on previous mark. The channel covers hoses on the bottom of the square tubing.
- Install hose guard using 2 drill screws (you may want to drill a $\frac{3}{16}$ pilot hole first).
- Place another hose guard against first and install in same manner.
- Repeat process for other boom side.
- Connect small plastic electrical plug under compressor to electrical extension cable.
- For *Spray Star 1600* route extension cable under engine along the mainframe cross bar, using tie downs as necessary.
- Cut cable and strip casing, allowing enough length to connect to fuse block.
- Strip and connect slide on connectors to each wire and use the heat shrink.
- Connect black negative (-) wire to the ground and connect red wire to the positive (+).
- Insert 10 amp fuse into slot which red wire was attached to.

14-291 FOAM MARKER



REF#	PART#	DESCRIPTION	QUANTITY
1	15-507	Foamer Tubing	1
2	14-291-02	Tank	1
3	14-291-01	Black Cover	1
	14-291-03	Compressor Complete	1
4	14-284-02	Cap Assembly	1
5	14-291-04	Tank Bracket	1
6	14-291-05	Double Switch Box	1
7	15-511	Foam Nozzle	1
8	15-510-01	Nozzle Mounting Rod	1
9	16-987	Foam Nozzle Mounting Kit	1
	14-536	Compressor Sub-assembly	

15-511 FOAM NOZZLE SUBASSEMBLY

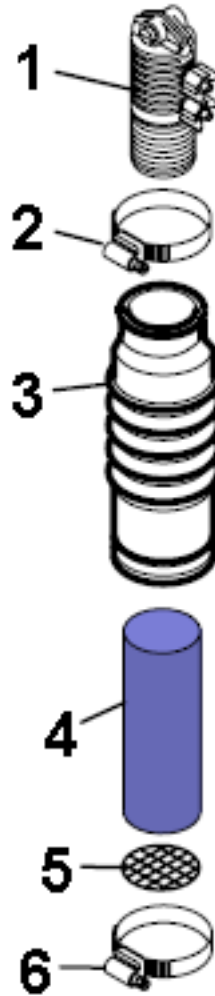

REF#	PART#	DESCRIPTION	QUANTITY
1*	15-511-01	Foam Nozzle Inlet Body	1
	15-511-02	Foam Sponge	1
	15-511-10	Plastic Screen	1
2*		Hose Clamp	1
3*		Drop Tube	1
4	15-511-08	Long Foam Sponge	1
5	15-511-09	Stainless Steel Screen	1
6		Hose Clamp	1
NS	15-510-01	Nozzle Mounting Rods	2
*	15-511-07	Foam Nozzle Sub Assembly	

15-363 FRESH WATER TANK

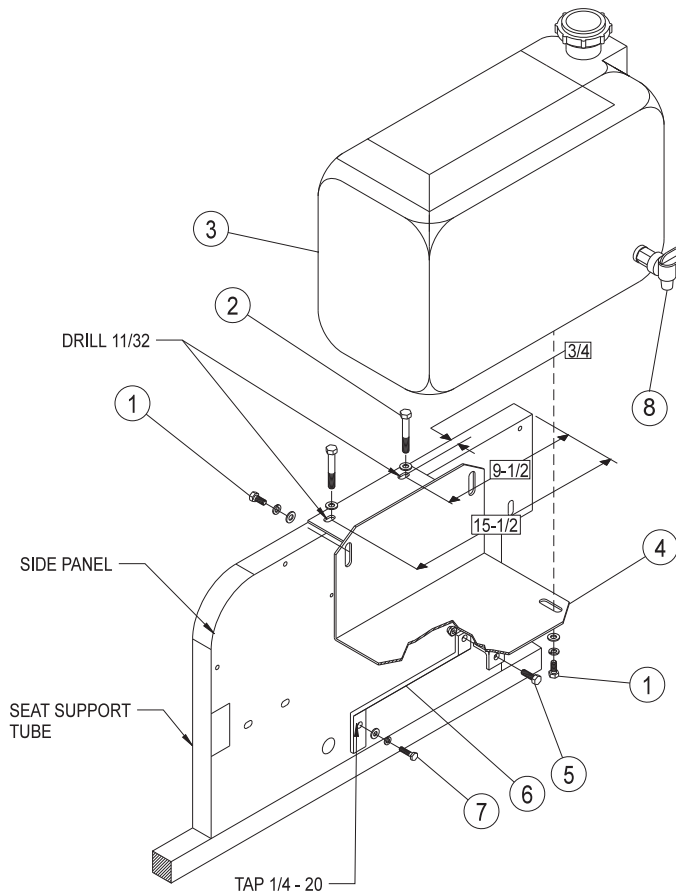

TO BE USED WITH 1602P AND 1604P

REF#	PART#	DESCRIPTION	QUANTITY
1	HB-516-18-075	Bolt $\frac{5}{16}$ - 18 x $\frac{3}{4}$	4
	HWL-516	Lockwasher $\frac{5}{16}$	4
	HW-516	Washer $\frac{5}{16}$	4
2	HB-516-18-225	Bolt $\frac{5}{16}$ - 18 x $2\frac{1}{4}$	2
	HW-516	Washer $\frac{5}{16}$	2
	HNTL-516-18	Lock Nut $\frac{5}{16}$ - 18	2
3	15-488	Wash Tank (includes all * items)	1
	16-166	Hex Plug $\frac{3}{4}$	2
4	15-486	Tank Bracket	1
5	HB-14-20-100	Bolt $\frac{1}{4}$ - 20 x 1	1
	HNTL-14-20	Lock Nut $\frac{1}{4}$ - 20	1
6	15-487	Support Brace	1
7	HB-14-20-100	Bolt $\frac{1}{4}$ - 20 x 1	1
	HWL-14	Lockwasher $\frac{1}{4}$	1
	HW-14	Washer $\frac{1}{4}$	1
8*	16-960	Spigot (part of 15-488)	1
9*	15-488-01	Cap(part of 15-488)	1
10*	15-488-02	Cover Assembly (part of 15-488)	1

1. Drill two $\frac{11}{32}$ holes through both walls of left side panel and seat support tube as shown in drawing.
2. Remove drill screw from bottom edge, in middle of side panel. Run a $\frac{1}{4}$ - 20 tap through this hole.
3. Bolt tank to tank bracket using four $\frac{5}{16}$ - 18 x $\frac{3}{4}$ bolts, $\frac{5}{16}$ lockwasher and $\frac{5}{16}$ washers.
4. Use Teflon[®] tape on each of the $\frac{3}{4}$ hex plugs and install into tank.
5. Bolt tank bracket to seat support tube where you drilled the two $\frac{11}{32}$ holes.
6. Bolt up support brace to tank bracket and side panel, as shown.

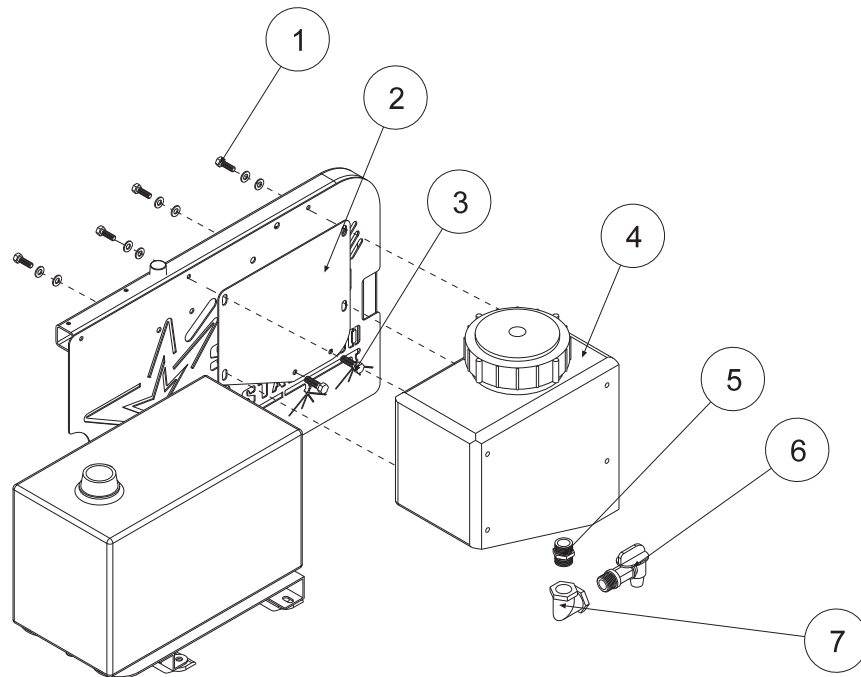

TO BE USED WITH 1610P

REF#	PART#	DESCRIPTION	QUANTITY
1	HB-516-18-075	Bolt $\frac{5}{16}$ - 18 x $\frac{3}{4}$	4
	HWL-516	Lock Washer $\frac{5}{16}$	4
	HW-516	Washer $\frac{5}{16}$	4
2	10-216	Fresh Water Tank Bracket	1
3	HB-38-16-200	Bolt $\frac{3}{8}$ - 16 x 2	2
	HNTL-38-16	Lock Nut $\frac{3}{8}$ - 16	2
4	10-234	3 Gallon Rectangular Tank	1
5	16-158	Close Nipple $\frac{3}{4}$ x $\frac{3}{4}$	1
6	16-960	Spigot $\frac{3}{4}$ NPT	1
7	16-151	Elbow FPT $\frac{3}{4}$ x $\frac{3}{4}$	1

1. Fresh Water Wash Tank mounts on the right side of the machine.
2. Insert the close nipple into the bottom of the tank. Then place the elbow on the close nipple so it is pointing away from the machine. Place the spigot into the elbow. For best results use plumbers tape on all fittings.
3. Place the mount bracket onto the right side panel using the two $\frac{3}{8}$ bolts and lock nuts.
4. Line holes on the tank with holes on the mount bracket and use the $\frac{5}{16}$ bolts to fasten tank to mount bracket.
5. Rinse tank with clear water and check for leaks around fittings.

This tank is for fresh clear water ONLY. Do not put chemicals in this tank.

14-515 WATER METER KIT (GALLONS)

15-618 WATER METER KIT (LITERS)

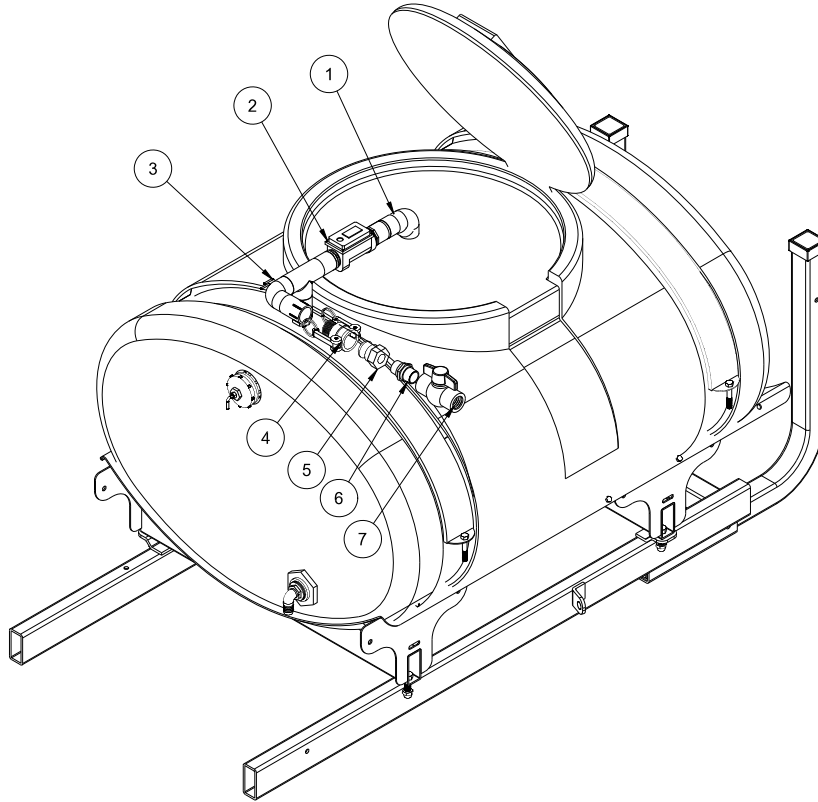

REF #	PART #	DESCRIPTION	QUANTITY
1	14-524	Filler Outlet	1
2	14-514	Water Meter (gallon)	1
	14-527	Water Meter (liters)	
3	14-525	Filler Inlet	1
4	16-962	Quick Coupler (already on machine)	1
5	16-961	Quick Coupler (already on machine)	1
6	16-851	1" Nipple	1
7	18-448	1" Ball Valve	1

1. Thoroughly flush the service line upstream of the meter to remove dirt and debris.
2. Set meter inline.
3. Make sure the water flow follows the arrow cast on the meter body.
4. The DLJ Meter is for use **only** with **COLD WATER** up to 122°F (50°C)
5. Slowly open any upstream valves to prevent damage to the meter.

Gallons to Cubic feet Conversion :

Multiply gallons reading by 0.1337 to get cubic feet.

There are 7.48052 gallons per cubic foot.

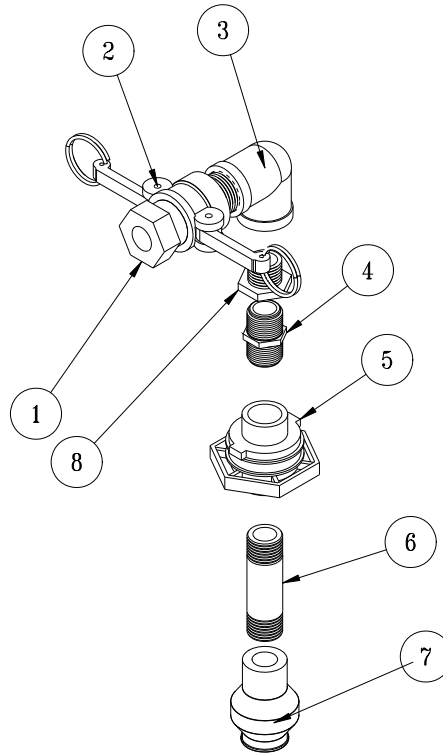

REF#PART#	DESCRIPTION	QUANTITY	
1	16-961	1" Adapter	1
2	16-962	1" Coupler	1
3	16-864	1" FTP Elbow	1
4	16-158	Close Nipple	1
5	16-150	Double Thread Fitting	1
6	16-172	4" Nipple	1
7	15-834	Tank Rinsing Nozzle	1
8	16-163	Reducer Bushing	1

Drill 1-3/4" hole 5" from outside edge of cover.
 Install Tank Rinsing kit as shown, with the Double Thread Fitting (Ref 5) going into the cover.

Basket Must be removed During Use.

33-541 triple Nozzle Kit for 15' Booms



CLEANLOAD EDUCATOR

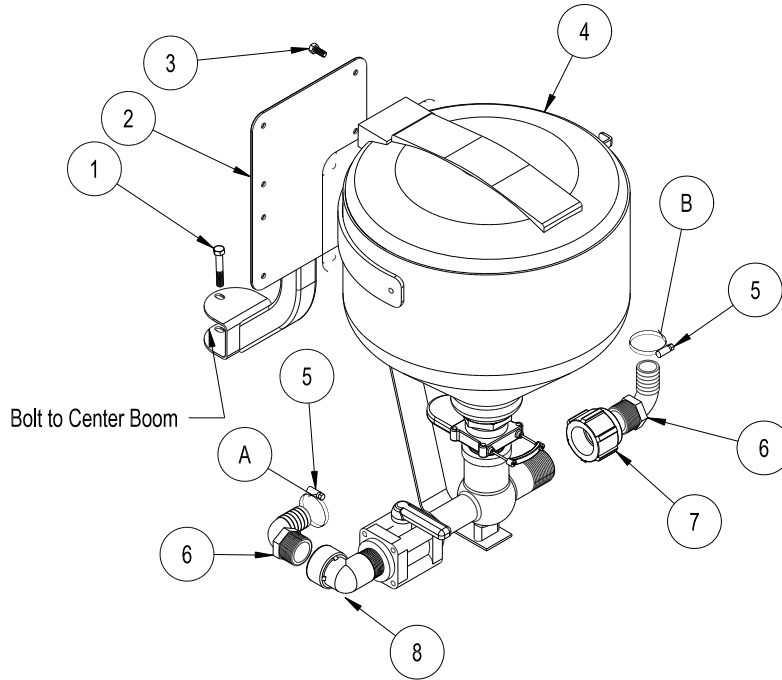

REF#	PART #	DESCRIPTION	QUANTITY
1	HB-38-16-300	Bolt $\frac{3}{8}$ -16 x 3	1
	HNTL-38-16	Flange Lock Nut $\frac{3}{8}$ -16	1
2	15-816	Mount Bracket	1
3	HBFL-516-18-075	Flange Bolt $\frac{5}{16}$ -18 x $\frac{3}{4}$	4
	HNFL-516-18	Flange Lock Nut $\frac{5}{16}$ -18	4
4	15-620	Cleanload Educator	1
5	18-116	Hose Clamps	4
	8897-36	1 $\frac{1}{4}$ Discharge Hose	2
6	16-156	90° Hose Barb	2
7	18-391	Reducer Coupling	1
A	8897-36	Hose to Tee by Valve	1
B	8897-36	Hose to 16-945-P in Back of Tank	1

DIAGRAM #1

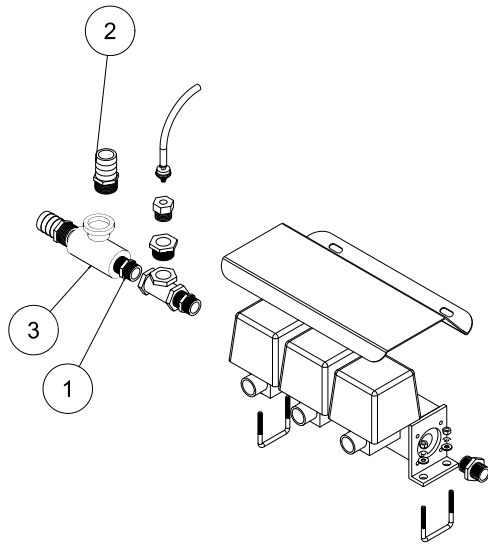

1604P (203 SYSTEM)

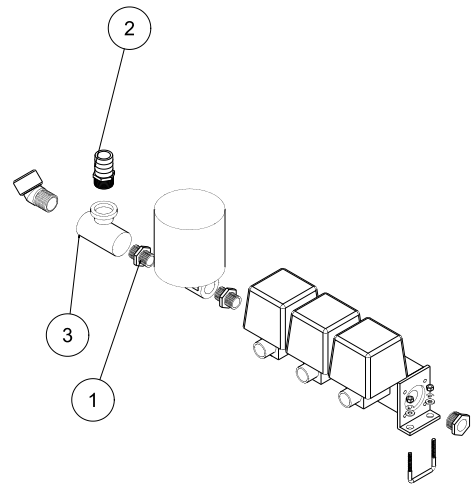

1602P (440 SYSTEM)

REF#	PART #	DESCRIPTION	QUANTITY
1	16-851	Close Nipple	1
2	16-159	Hose Barb	1
3	16-183	Tee	1

DIAGRAM #2

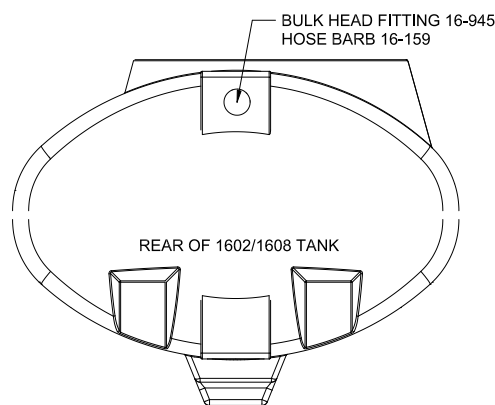

PARTLIST

1. Make sure sprayer tank is empty and flush all chemical residue from sprayer.
2. Disconnect inlet hose from left hand side of ball valve on the rear of the machine. Then remove barb fittings that inlet hose was attached too.
3. Install the following fittings into the ball valve, being sure to use a thread sealant of some type on all of the fittings. First install a 16-854 Nipple, 16-183 Tee, another 16-854 Nipple and the hose barb you removed in step 2. Thread in a 16-159 Hose barb into the side port on the tee then tighten all fittings with the hose barb in the side port pointing to the rear of the machine. (See diagram #1).
4. Drill a 2-1/4" hole in the upper center of the Spray Tank and install a bulkhead fitting (16-945) from the inside of the tank pointing outward, with the nut on the outside then tighten. Install a 16-159 Straight hose barb into bulkhead fittings. (See diagram #2)
5. Install mount bracket into left rear boom support tube. Secure with two, $\frac{3}{8} \times 2\frac{3}{4}$ bolts and flange nuts, then tighten. There are two sets of mount holes in the mount bracket, so it can be used with either boom. The mount bracket must clear the boom holder brackets.
6. Attach the Cleanload Assembly to mount bracket using four $\frac{5}{16} \times \frac{3}{4}$ bolts and flange nuts.
7. Install 18-391 Reducer Coupling to outlet side of Cleanload Assembly. Then install the last two 90° hose barbs, one into the inlet side and one into the outlet side. The inlet side fitting should point down and forward. The outlet fitting should point upward.
8. Install inlet hose from the tee in the main feed line to the inlet side (yellow handle). Hose will need to be cut to length depending on what model sprayer you are working on. Secure hose with hose clamps provided.
9. Install outlet hose from the outlet side of the Cleanload Assembly to the fitting on the rear of the tank. Hose will need to be cut to length. Then secure with hose clamps.
10. Make sure all fittings, hoses and hardware in tight.
11. Add about 25 gallons of water to sprayer tank. Start machine and pump the water through the Cleanload Assembly to check for leaks.
12. Be sure to read start up, loading and shutdown instructions for Cleanload Assembly before using with chemicals. When working with chemicals always wear protective clothing, goggles and gloves.

CLEANLOAD FRESHWATER MOUNT ON 17-17-550/17-525 BOOMS

When placing a 17-525/17-550 Heavy Boom on the Sprayer you will have to relocate the Chemical Cleanload System and the Fresh Water tank. There is a mount provided for you, please see in the illustration.

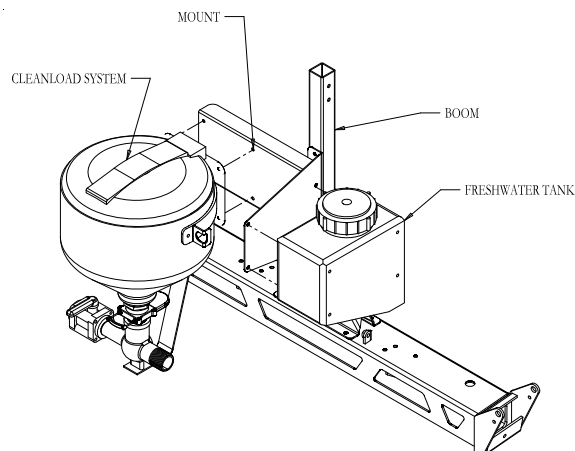

STARTUP

1. All Cleanload valves must be closed prior to starting: inlet ball valve, knife valve and hopper rinse ball valve.
2. Open lid to check for foreign objects which may hinder performance or contaminate the system.
3. Close and lock lid by turning cover clockwise.
4. Divert pump flow to Cleanload inlet line. A pressure of 30 PSI minimum and 150 PSI maximum must be used. Highest pressures increase eduction rate and available wand suction.
5. Turn inlet ball valve on (yellow handle).
6. Open knife valve, located on the bottom of hopper, by pushing handle in (red handle).
7. Unlock and open lid slowly by turning cover counterclockwise.

LOADING LIQUID OR POWDERED CHEMICAL INTO HOPPER

8. Pour required amount of chemical into hopper. Avoid splashing liquids or powdered chemicals outside of hopper.
9. Rinse empty chemical containers if applicable. Place container opening over container rinse valve and press down. This will activate the rinse valve and rinse container.
10. Rinse Cleanload hopper. Close and lock lid by turning cover clockwise. Release the safety locking band on the hopper rinse ball valve and turn on for 20 seconds. Close ball valve and return locking band to locked position.
11. Open lid and inspect for chemical residue. Repeat step 10 as necessary.
12. Close knife valve by pulling red handle out towards you. Turn inlet (yellow handle) off.

LOADING LIQUID AND/OR POWDERED CHEMICAL WITH SUCTION LANCE

Note: Lance suction is dependent upon eductor pressure and flow. For best results, use highest pressure available up to 150 PSI maximum.

8. Insert lance body with o-ring into eductor until the o-ring is sealed.
9. Use the free end of the lance to pierce bag or container to vacuum powdered or liquid chemical.
10. Rinse lance. Place lance end into a clean container of water to rinse lance assembly.
11. Remove lance body from eductor and drain any remaining fluid into hopper.
12. Close knife valve (red handle). Turn inlet valve (yellow handle) off.

SHUTDOWN

1. Ensure that:
 - All valves are closed. Be sure to close knife valve first. (Close by pulling red handle out towards you.)
 - Chemical residue has been cleaned.
 - Hopper lid is closed and locked by turning cover clockwise.
2. Divert pump flow back to normal operation.

TROUBLESHOOTING

Symptom	Corrective Action
Low education rate	Check pump pressure and flow. Cleanload Eductor performance is based on flow and pressure to the system. Note requirements for high education rates.
	Increase outlet hose size back to tank.
Plugged or clogged bottle rinse nozzle	Disassemble rotary portion of nozzle from lower valve assembly and back flush until nozzle ports are clear of debris.
Plugged or clogged tank rinse nozzle	Disassemble rotary portion of nozzle from NPT hose barb and back flush until nozzle ports are clear of debris. Remove screen and flush with water to clear away foreign material.
Fitting leaks	Check for cracks in fitting. Replace fitting if necessary. Disassemble and add more joint seal in compound if leak occurs on threads.

This is a list of decals located on the Spray Star 1600P. Part number, description and location will help in re-ordering decals.

13-063	Multiple Warning	Right Side of Seat in Front of Controls Facing Operator
14-346	Sprayer Dash	Dashboard
14-296	Control Panel	Control Panel
14-510	Tank Volume Side	Side of tank
14-511	Tank Volume Back	Back of Tank
15-462	Hang Tag	Hang From Steering Wheel
15-463	Spray Pump	Seat Panel
14-454	Spray Star 1600	Tank Sides
16-011	Shift Knob	Shift Knob
16-088	Moving Parts Hot	Pump Guard
16-228	Not a Motor Vehicle	In Front of seat Left Side
16-858	Caution Steering	Dashboard by Steering Column
25-279	Safety Warning	Under Seat Cover
25-286	Pinch Point	Left and Right Side Panel
25-298	Warning Hot	Right Exhaust Guard/ Right Side of Frame Next to Muffler
25-307	Gas Refuel	Below Gas Tank
25-355	Tire Pressure 18PSI	Front Tires
25-356	Tire Pressure 20PSI	Rear Tires
25-373	Smithco	Front Nose Cone
25-369	84 dBa	Console
27-077	Smithco - Round	Steering Wheel
27-093	Hydraulic Oil	Left Exhaust Guard by Dipstick/ Left Side Frame by Oil Reservoir
27-277	Battery	Battery Plate

QUICK REFERENCE REPLACEMENT PARTS

REPLACEMENT FILTERS

78-090	Oil Filter	Kohler # 12 050 01
78-088	Air Cleaner	Kohler # 47 083 03
78-089	Pre-Cleaner	Kohler # 24 083 02
50-403	Fuel Filter	
13-288	Key Switch	Kohler # 25 099 04
76-310	Key Set	

REPLACEMENT BELTS

16-827	Foot Clutch Belt
16-869	Spray Pump Belt
15-320	Hydraulic Pump Belt

SEAL KITS

15-315	Hydraulic Power Unit
15-315-01	Repair Kit
15-301	Power Steering Orbital Motor
15-301-01	Seal Kit
77-263	Hydraulic Cylinder
14-530	Seal Kit
11-158 and 16-754	Linear Actuators
11-158-01	Seal Kit
50-123	Brake Master Cylinder
50-123-02	Brake Master Cylinder Repair Kit

FLUIDS

Brake Fluid	Dot 3
Engine Oil	SAE 10W-40 API Service SJ or higher Motor Oil
Hydraulic Fluid	SAE 10W-40 API Service SJ or higher Motor Oil
Rear Axle Fluid	SAE 80W-90 Gear Lube API Service GL-5, GL-4
Transmission Fluid	SAE 80W-90 Gear Lube API Service GL-5, GL-4

OTHER PARTS

16-953	Hinged Cover On Tank with Gasket	
16-953-01	Gasket For Cover	
16-169	Strainer Basket	
	Spark Plugs	Champion type RC12YC (Gap 0.040 inch (1.02mm))

The Smithco Commercial Products Two-Year Limited Warranty

Smithco, Inc. (Smithco) warrants your 2007 or newer Smithco Commercial Product ("Product") purchased after January 1, 2007, to be free from defects in materials or workmanship for the period of time listed below. Where a warrantable condition exists, Smithco will repair the Product at no cost to you including diagnosis, labor (at the Smithco standard labor rate, subject to the Smithco flat rate schedule), and parts.

Warranty Duration is:

- (1) Two years, 1500 operational hours* from the date of delivery to the original purchaser or three years from the date of original manufacturer of the product, whichever occurs first. (*Products equipped with hour meter).
- (2) Products used in rental situations are covered for 90 days from date of delivery to original user/ renter.

Owner Responsibilities:

As the Product owner, you are responsible for required maintenance and adjustments stated in your Owner's Manual. Failure to perform required maintenance and adjustments can be grounds for disallowing a warranty claim. **You are particularly responsible to train all present and future operators of this product on the safe operation of this product at your location.**

Instructions for Obtaining Warranty Service:

You are responsible for notifying the Authorized Smithco Products Distributor from whom you purchased the Product as soon as you believe a warrantable condition exists and not later than 30 days from discovery of the condition.

If you need help locating an Authorized Smithco Distributor, or if you have questions regarding your warranty rights or responsibilities, you may contact us at:

Smithco Product Support Department
200 W Poplar PO Box 487
Cameron, Wisconsin 54822

Telephone: 1-800-891-9435 E-Mail: ProductSupport@smithco.com

Maintenance Parts:

Parts scheduled for replacement as required maintenance ("Maintenance Parts"), are warranted for the period of time up to the scheduled replacement time for that part.

Items/Conditions Not Covered:



Not all product failures or malfunctions that occur during the warranty period are defects in materials or workmanship. The items/conditions listed below are not covered by this warranty:



Product failures which result from the use of non-Smithco replacement parts, or from installation and use of add-on, modified, or unapproved accessories are not covered.



Product failures which result from failure to perform required maintenance and/or adjustments are not covered.



Product failures that result from operating the Product in an abusive, negligent or reckless manner are not covered.



This warranty does not apply to parts subject to consumption through use, unless found to be defective. Examples of parts which are consumed, or used up, during normal Product operation include, but are not limited to: blades, tines, teeth, scarifiers, rakes, plates, wear plates, castor wheels, tires, batteries, filters, belts, nozzles, etc.



This warranty does not apply to failures caused by outside influence. Items considered to be outside influence include, but are not limited to, weather, storage practices, contamination, use of unapproved coolants, lubricants, additives, or chemicals, etc.



This warranty does not apply to normal “wear and tear” items. Normal “Wear and Tear” includes, but is not limited to, damage to seats due to wear or abrasion, worn painted surfaces, scratched decals or windows, etc.



Smithco may require the return of failed parts or components in order to determine the validity of any warranty claim.



Smithco will not be obligated to replace components of other manufacturers if inspection by the original component manufacturer indicates that failure was due to normal wear and tear, expected consumption through use or improper care or service.

Other Legal Disclaimers:

The above remedy for product defects through repair or replacement by an authorized Smithco distributor or dealer is the purchaser’s sole remedy for any defect. This warranty gives you specific legal rights, and you may also have other rights which vary from state to state.

THERE ARE NO OTHER EXPRESS WARRANTIES OTHER THAN THOSE SET FORTH ABOVE. ALL IMPLIED WARRANTIES OF MERCHANTABILITY AND FITNESS FOR USE ARE LIMITED TO THE DURATION OF THE LIMITED WARRANTIES CONTAINED HEREIN.

Some states may not allow limitations on how long an implied warranty lasts, so the above limitation may not apply to you.

THE SMITHCO COMPANY IS NOT LIABLE FOR INDIRECT, INCIDENTAL OR CONSEQUENTIAL DAMAGES IN CONNECTION WITH THE USE OF THE PRODUCT, INCLUDING ANY COST OR EXPENSE OF PROVIDING A SUBSTITUTE PRODUCT OR SERVICE DURING PERIODS OF MALFUNCTION OR NON-USE.

Some states may not allow the exclusion of indirect, incidental or consequential damages, so the above exclusion may not apply to you.

Smithco neither assumes, nor authorizes any person to assume for it, any other liability in connection with the sale or use of this product.

SMITHCO, INC.

Wayne, PA 19087

