

**SMITHCO**

Wayne, Pennsylvania 19087

# **PARTS & SERVICE MANUAL**

**Spray Star  
Model 1600**

**PRIME MOVER**

**Starting Serial #992**

**February, 2002**

SMITHCO PRODUCT SUPPORT

1-800-891-9435

Hwy SS and Poplar Avenue, Cameron WI 54822

E-mail: [productsupport@smithco.com](mailto:productsupport@smithco.com)

# CONTENTS

Introduction

## Introduction ..... 1-3

Introduction .....	1
General Safe Practices .....	2
Specifications .....	3
Optional Spray Equipment .....	3

Service

## Service ..... 4-12

Maintenance .....	4-6
Axle Shaft Disassembly .....	7-8
Axle Shaft Assembly .....	8-9
Service Chart .....	10
End User's Service Chart .....	11
Adjustments .....	12
Storage .....	12

Diagrams

## Diagrams ..... 14-17

Hydraulic Diagram .....	14-15
Wiring Diagram .....	16-17

Parts

## Parts ..... 18-55

Body & Frame .....	18-19
Tank & Rear Fenders .....	20-21
Nose Cone .....	22-25
Brake .....	26-27
Pumps And Exhaust .....	28-29
Spray Pump .....	30-31
Front Axle .....	32-33
Clutch Linkage .....	34-35
Engine and Control Panel .....	36-39
Gas Tank .....	40-41
Turbo Quad Agitator .....	42-43
14-371 Strainer .....	42-43
15-301 Orbitor .....	44-45
15-409 3-Speed Transmission .....	46-49
16-998 Hypro® Pump .....	50-51
16-037 Rear Axle .....	52-53
Brake Assembly .....	54-55

Accessories

## Accessories ..... 56-128

Plumbing 1602P System (Raven 440) .....	56-57
Plumbing 1604P System (Raven 203) .....	58-59
Plumbing 1610P System (Manual) .....	60-61
Controls 1602P System (Raven 440) .....	62-63
Control 1604P System (Raven 203) .....	62-63
15-515 Flow Meter .....	64-65
16-524 & 16-995 Motorized Control Valve .....	66-67
16-456 Flow Meter .....	66-67
10-268 3-Way Manual Valve .....	68-69
14-348 Solenoid Valve .....	70-71
10-300 18' Terrain Following Boom .....	72-77
15-493 Stainless Steel 18' Auto Boom .....	78-81
15-577 Stainless Steel 18' Manual Boom .....	82-85
10-300 and 15-493 Boom Wiring Diagram .....	86-87
Nozzle Assembly .....	86-87
14-100 Boom .....	88-89
14-100 Plumbing & 16-807 Nozzle Kit .....	90-91
Plumbing & Nozzle Kit Installation .....	91
14-101 Plumbing & 709-420 Nozzle Kit .....	92-93
Plumbing & Nozzle Kit Installation .....	93
Turbo TurfJet Tips .....	94
XR TEEJET Tips .....	95
16-906 Electric Hose Reel .....	96-97
16-129 Hose Reel .....	98-99
14-311 Hose Reel Installation .....	100-101
Hose Reel Adjustments .....	102
Electric Hose Reel Wiring Diagram .....	102-103
14-283 Foam Marker Installation .....	104-109
14-284 Foamer .....	110-111
15-505 Motor Sub Assembly .....	112-113
15-511 Foam Nozzle Sub Assembly .....	114-115
15-363 Fresh Water Tank For 1602P and 1604P .....	116-117
10-106 Fresh Water Tank For 1610P .....	118-119
14-305 Cab .....	120-125
15' Star Shield Boom .....	126-128

## Reference ..... 129-130

Decal List .....	129
Quick Reference Replacement Parts .....	130
Limited Warranty .....	Inside Back Cover

Reference

Thank you for purchasing a **SMITHCO** product.

Read this manual and all other manuals pertaining to the Spray Star carefully as they have safety, operating, assembly and maintenance instructions. Failure to do so could result in personal injury or equipment damage. Keep manuals in a safe place after operator and maintenance personnel have read them. Right and left sides are from the operator's seat, facing forward.

All **SMITHCO** machines have a Serial Number and Model Number. Both numbers are needed when ordering parts. The serial number plate on the Spray Star is located on the front left side of the main frame. Refer to engine manual for placement of engine serial number.

For easy access record your Serial and Model numbers here.

<b>SMITHCO</b> WAYNE, PENNSYLVANIA 19087 USA 610-688-4009 Fax 610-688-6069			
<input type="text"/>	<input type="text"/>	<input type="text"/>	YEAR OF MFG. <input type="text"/>
SERIAL NO. <input type="text"/>	<input type="text"/>	<input type="text"/>	kW/hp
MODEL NO. <input type="text"/>	<input type="text"/>	<input type="text"/>	kg/lb

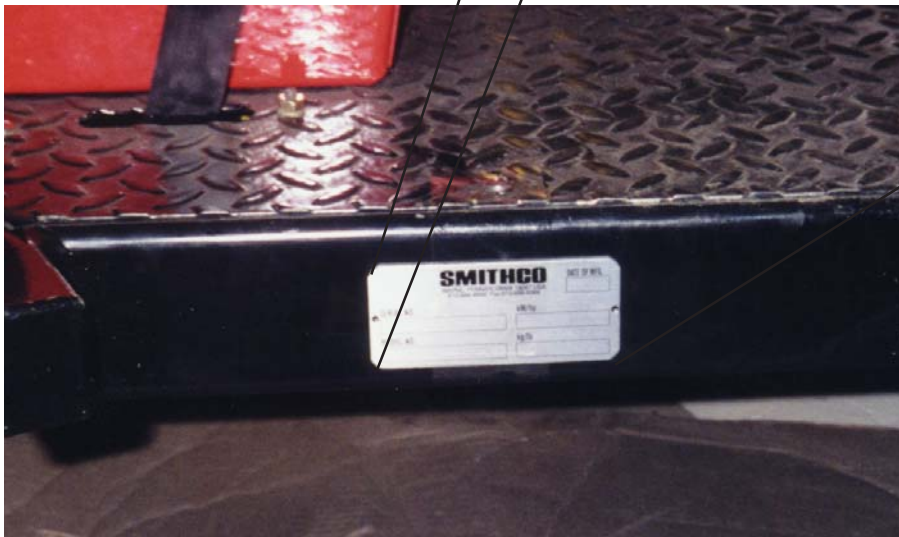

Information needed when ordering replacement parts:

1. Model number of machine.
2. Serial number of machine.
3. Name and part number of part.
4. Quantity of parts.

## GENERAL SAFE PRACTICES

1. It is your responsibility to read this manual and all publications associated with this machine.
2. Never allow anyone to operate or service the machine or its optional equipment without proper training and instructions. Never allow minors to operate any equipment.
3. Learn the proper use of the machine, the location and purpose of all the controls and gauges before you operate the equipment. Working with unfamiliar equipment can lead to accidents.
4. Wear all the necessary protective clothing and personal safety devices to protect your head, eyes, ears, hands and feet. Operate the machine only in daylight or in good artificial light.
5. Inspect the area where the equipment will be used. Pick up all debris you can find before operating. Beware of overhead obstructions and underground obstacles. Stay alert for hidden hazards.
6. Never operate equipment that is not in perfect working order or without decals, guards, shields, or other protective devices in place.
7. Never disconnect or bypass any switch.
8. Carbon monoxide in the exhaust fumes can be fatal when inhaled, never operate a machine without proper ventilation.
9. Fuel is highly flammable, handle with care.
10. Keep engine clean. Allow the engine to cool before storing and always remove the ignition key.
11. Disengage all drives and set park brake before starting the engine.
12. Never use your hands to search for oil leaks. Hydraulic fluid under pressure can penetrate the skin and cause serious injury.
13. This machine demands your attention. To prevent loss of control or tipping of the vehicle:
  - A. Use extra caution in backing up the vehicle. Ensure area is clear.
  - B. Do not stop or start suddenly on any slope.
  - C. Reduce speed on slopes and in sharp turns. Use caution when changing directions on slopes.
  - D. Stay alert for holes in the terrain and other hidden hazards.
14. Before leaving operator's position:
  - A. Disengage all drives.
  - B. Set park brake.
  - C. Shut engine off and remove the ignition key.
  - D. If engine has to run to perform any maintenance keep hands, feet, clothing and all other parts of body away from moving parts.
15. Keep hands, feet and clothing away from moving parts. Wait for all movement to stop before you clean, adjust or service the machine.
16. Keep the area of operation clear of all bystanders.
17. Never carry passengers.
18. Stop engine before making repairs/adjustments or checking/adding oil to the crankcase.
19. Use parts and materials supplied by **SMITHCO** only. Do not modify any function or part.
20. Use caution when booms are down as they extend out beyond the center line of the machine approximately 10 ft. (3 m).
21. The tank is a confined space, take precaution.

***These machines are intended for professional maintenance on golf courses, sports turf, and any other area maintained turf and related trails, paths and lots. No guaranty as to the suitability for any task is expressed or implied.***

# SPECIFICATIONS SPRAY STAR 1600P

## WEIGHTS AND DIMENSIONS

Length	112" (285 cm)		
Width	61" (155 cm)	Width With Booms Down	230" (584 cm)
Height	50" (127 cm)	Height With Booms Up	126" (320 cm)
Wheel Base	60" (152 cm)		
Weight Empty	1200 lb (544 kg)	Weight Loaded	2500 lb (1134 kg)

## SOUND LEVEL AT 3400 RPM

At ear level	84 dB
At 3 ft. (0.914 m)	82 dB
At 30 ft (9.14 m)	68 dB
At 23 ft (7 m) pass by	70 dB

## ENGINE

Make	Kohler
Model#	Command CH20S
Type / Spec#	64558
Horsepower	20 hp (15 kW)
Fuel	Unleaded 87 Octane Gasoline Minimum
Cooling System	Air cooled
Lubrication System	Full pressure
Alternator	25 Amp

## WHEELS & TIRE

Front (2) 20 x 1000 x 10 Multi-rib 20 psi (1.4 bar)  
Rear (2) 24 x 1300 x 12 Super Soft 18 psi (1.3 bar)  
Ground Pressure: 8.2 psi with 160 gallons

## SPEED

Working Speed	1st gear 0-3 m.p.h. (0-5 kph) 2nd gear 2-6 m.p.h. (3-10 kph)
Transport Speed	3rd gear 4-10 m.p.h. (6-16 kph)
Reverse Speed	0-3 m.p.h. (0-5 kph)

## BATTERY

	Automotive type 24F-12 volt
BCI Group	Size 24
Cold Cranking Amps	575 minimum
Ground Terminal Polarity	Negative (-)
Maximum Length	10.25" (26 cm)
Maximum Width	6.88" (17 cm)
Maximum Height	10" (25 cm)

## FLUID CAPACITY

Crankcase Oil	2.1 quart (2 liters) with filter
Fuel	5 gallon (19 liters)
Hydraulic Fluid	1 gallon (3.785 liters)
Grade of Fluid	SAE 10W-40 API Service SJ or higher motor oil

# OPTIONAL SPRAY EQUIPMENT

33-216	Battery 24F-12 Volt	10-300	18' Terrain Following Boom
15-363	Fresh Water Wash Tank	14-100	Super Boom 20' (6 m) Long
14-311	Hose Reel Mounting Kit	15-493	Auto-Boom 18' (5.5 m) Long
15-571	15' Tri-Section Electric Lift Star Shield Boom	15-577	18' Manual Lift Boom
15-572	15' Dual Section Electric Lift Star Shield Boom	14-301	440 Spray System (1602P)
15-573	15' Manual Lift Star Shield Boom	14-302	203 Spray System (1604P)
16-856	Tank Rinsing System	14-303	Manual Spray System (1610P)
16-129	Manual Hose Reel 200' (61 m) capacity(to be used with 14-311)	14-305	Operator Protection Enclosure
16-906	Hose Reel 12 volt electric rewind 200' (61 m) capacity (to be used with 14-311)	14-283	Foam Marker System (Factory Installed)
13-210	Battery	14-285	Foam Marker System (Dealer Installed)



## MAINTENANCE



Before servicing or making adjustments to machine, stop engine and remove key from ignition. When servicing the spray pump or filter all control valves must be shut off if there is liquid in the tank.

### NOTE:

Use all procedures and parts prescribed by the manufacturer's. Read the engine manual before operation.

The suggested maintenance checklist is not offered as a replacement for the manufacturer's but as a supplement. You must adhere to guidelines established by manufacturer for warranty coverage. In adverse conditions such as dirt, mud or extreme temperatures, maintenance should be more frequent.

### LUBRICATION

Use No. 2 General purpose Lithium Base Grease and lubricate every 100 hours. The Spray Star 1600P has 7 grease fittings.

- One on the rod end of hydraulic cylinder.
- One on each the right and left spindles.
- One on the front axle.
- One on clutch idler arm.
- One on each end of the drive line.

### AIR CLEANER

- Loosen cover retaining knob and remove cover.
- Remove precleaner from paper element.
- Check paper element. Replace element as necessary.
- Wash precleaner in warm water with detergent. Rinse precleaner thoroughly until all traces of detergent are eliminated. Squeeze out excess water (do not wring). Allow precleaner to air dry.
- Saturate precleaner with new engine oil. Squeeze out all excess oil.
- Reinstall precleaner over paper element.
- Reinstall air cleaner cover. Secure cover with cover retaining knob.

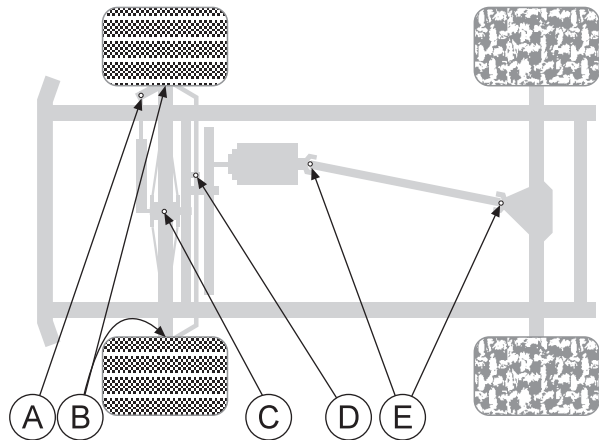

### HYDRAULIC OIL

- Use SAE 10W-40 API Service SJ or higher motor oil.
- For proper warranty, change oil every 500 hours or annually, which ever is first.
- Oil level should be 1.5" (4 cm) from top of tank when fluid is cold. Do not overfill.
- After changing oil, run the machine for a few minutes. Check oil level and for leaks.
- Always use extreme caution when filling hydraulic oil tank or checking level to keep system free of contaminants. Check and service more frequently when operating in extremely cold, hot or dusty conditions.
- If the natural color of the fluid has become black or smells burnt, it is possible that an overheating problem exists.
- If fluid becomes milky, water contamination may be a problem.
- If either of the above conditions happen, change oil immediately after fluid is cool and find the cause. Take fluid level readings when the system is cold.
- In extreme temperatures you can use straight weight oil. We recommend SAE 30W API Service SJ or higher when hot (above 90°F (33°C)) and SAE 10W API Service SJ or higher when cold (below 32°F (0°C) ambient temperature. Use either motor oil or hydraulic oil, but do not mix.

- Oil being added to the system must be the same as what is already in the tank. Mark the tank fill area as to which type you put in.



## ENGINE OIL

Change and add oil according to chart below based on air temperature at the time of operation. Do not overfill. Use a high quality detergent oil classified "For Service SJ or higher" oil. Use no special additives with recommended oils. Do not mix oil with gasoline.

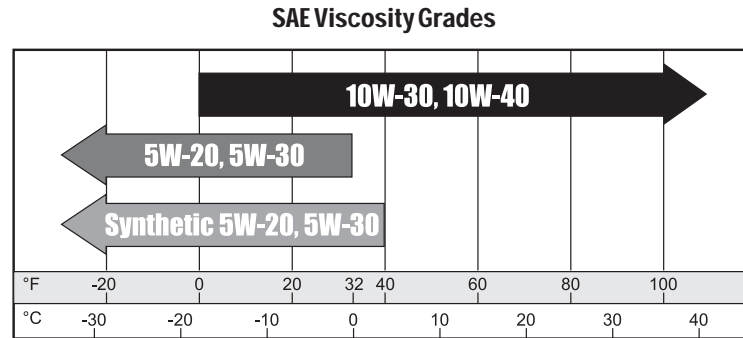

**Starting Temperature Range Anticipated Before Next Oil Change**

## DIRECTO VALVES

Directo Valves should be disassembled, cleaned, inspected, and a service kit installed annually. More often depending on the chemicals being used and the frequency of use. In most cases this can be done without removing the valve from the sprayer.

## HYPRO PUMP

1. After use, flush pump with clean water.
2. Hypro diaphragm pumps come with oil in the crankcase. Hypro recommends changing oil after 40 hours of break-in operation and every three months or 500 hours, whichever comes first. Hypro recommends a high grade, nondetergent, SAE 30 weight oil.
3. For winter storage or if a freezing condition will be encountered, flush pump with a 50/50 mixture of water and antifreeze.

## DIAPHRAGM AND VALVE REPLACEMENT

1. Occasionally debris can cause the valves to not seal properly or damage the O-rings.
2. To check for this remove the pump manifold. With manifold removed, valves can readily be removed and checked for debris or wear. To replace valves or o-rings, refer to the Parts List for appropriate kits.
3. Hypro recommends changing diaphragms every 500 hours or three months, whichever comes first.
4. Drain the oil from the pump by removing drain plug. Rotate the shaft to remove excess oil.
5. Remove the pump manifold, remove the diaphragm retaining bolt, support washer and diaphragm. To replace the diaphragms order appropriate repair kit from parts list.
6. Turn the crankshaft to bring the piston to its upstroke to replace the diaphragm. Use the downstroke to seat the new diaphragm into the sleeve groove. Install retaining washer and tighten nut.
7. Replace the pulsation dampener diaphragm by first bleeding the air from the dampener. After replacing the diaphragm recharge dampener to 20% of operating pressure.
8. Refill crankcase with oil. Rotate shaft slowly forward and reverse to distribute oil and fill to proper level.

## MAINTENANCE (CONTINUED)

### TIRE PRESSURE

Caution must be used when inflating a low tire to recommended pressure. Over inflating can cause tires to explode. Front tires should be 20 psi (1.4 bar) and rear tires should be 18 psi (1.3 bar). Improper inflation will reduce tire life considerably.

### WHEEL MOUNTING PROCEDURE

1. Set park brake. Turn machine off and remove key.
2. Block wheel on opposite corner.
3. Loosen nuts slightly on wheel to be removed.
4. Jack up machine being careful not to damage underside of machine.
5. Place wheel on hub lining up bolt holes.
6. Torque to 64-74 ft/lb (87-100 Nm) using a cross pattern. Torque again after first 10 hours and every 200 hours thereafter.
7. Lower machine to ground and remove blocks and jack.

### BATTERY

Batteries normally produce explosive gases which can cause personal injury. Do not allow flames, sparks or any ignited objects to come near the battery. When charging or working near battery, always shield your eyes and always provide proper ventilation.

Battery cable should be disconnected before using "Fast Charge".

Charge battery at 15 amps for 10 minutes or 7 amps for 30 minutes. Do not exceed the recommended charging rate. If electrolyte starts boiling over, decrease charging.

Always remove grounded (-) battery clamp first and replace it last. Avoid hazards by:

1. Filling batteries in well-ventilated areas.
2. Wear eye protection and rubber gloves.
3. Avoid breathing fumes when electrolyte is added.
4. Avoid spilling or dripping electrolyte.



**WARNING**

**Battery Electrolyte is an acidic solution and should be handled with care. If electrolyte is splashed on any part of your body, flush all contact areas immediately with liberal amounts of water. Get medical attention immediately.**

### JUMP STARTING

To jump start (negative grounded battery):

1. Shield eyes.
2. Disconnect computer supply leads.
3. Connect ends of one cable to positive (+) terminals of each battery, first (A) then (B).
4. Connect one end of other cable to negative (-) terminal of "good" battery (C).
5. Connect other end of cable (D) to engine block on unit being started (NOT to negative (-) terminal of battery)

To prevent damage to other electrical components on unit being started, make certain that engine is at idle speed before disconnecting jumper cables.

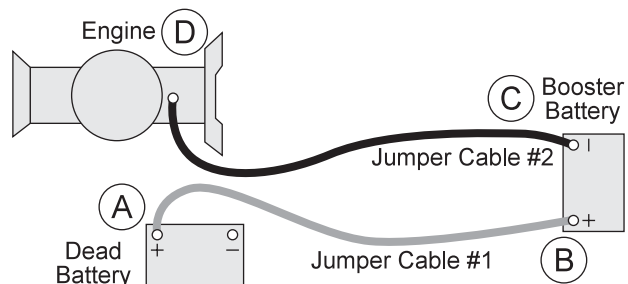

**WARNING**

**Use of booster battery and jumper cables. Particular care should be used when connecting a booster battery. Use proper polarity in order to prevent sparks.**



## AXLE SHAFT DISASSEMBLY



1. After the wheel is removed, remove the brake drum.

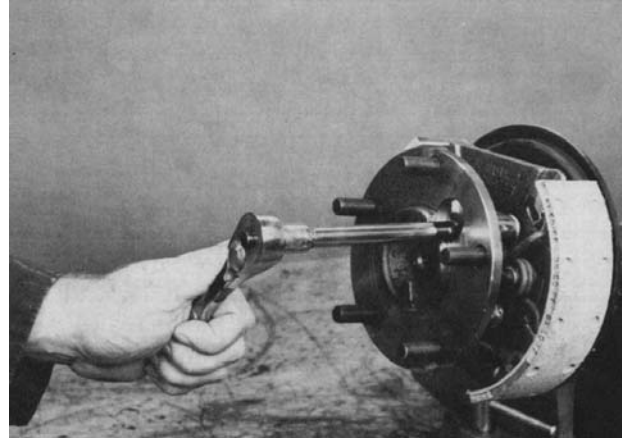

2. Using a  $\frac{1}{2}$ " socket, line up the hole in the axle shaft flange to remove the backing plate nuts which hold the axle shaft assembly to the axle.



3. To remove the axle shaft assembly, grasp the axle shaft assembly with both hands (the assembly includes axle shaft, oil seal, brake assembly, gasket, bearing, and retainer) and pull the axle shaft free.

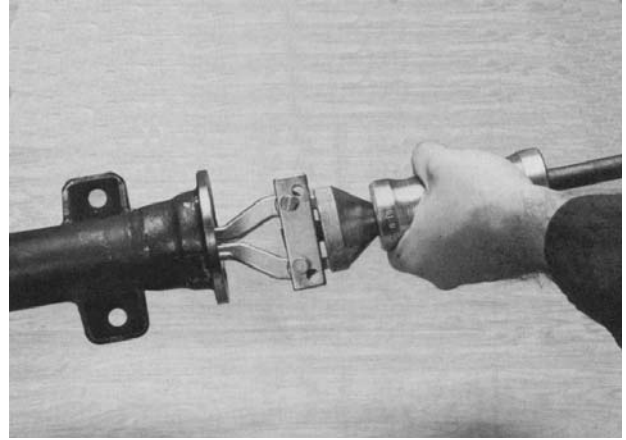

4. Remove inner Axle shaft seal using puller as shown. Discard Seal and replace with new one at time of assembly.



5. Place Axle shaft assembly in a vise. Center punch the outside of the retaining ring.

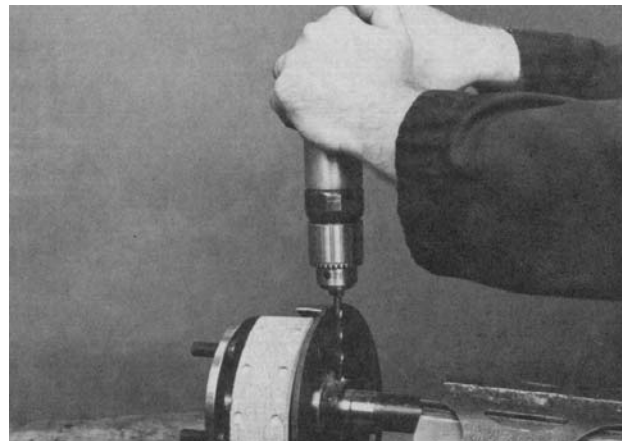

6. Drill a  $\frac{1}{4}$ " hole in the outside of the retainer ring to a depth approximately  $\frac{3}{4}$  the thickness of the ring. Drilling Completely through retainer ring will damage the shaft.

## AXLE SHAFT DISASSEMBLY (CONTINUED)

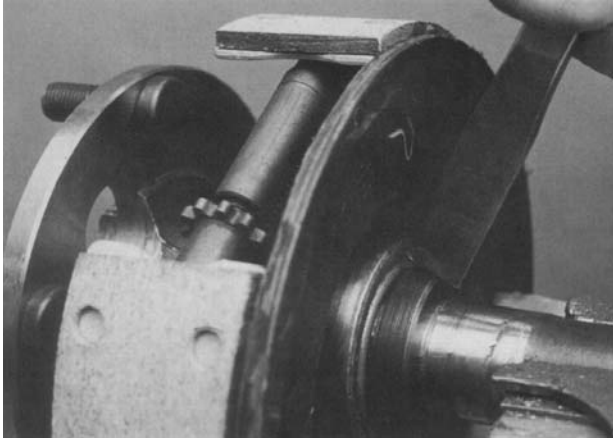

7. After drilling, position a chisel across the hole and strike sharply to break the ring. Replace with a new retaining ring when reassembly.

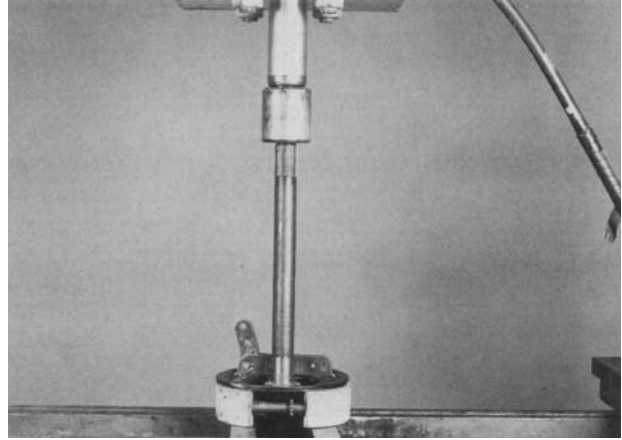

8. Support the axle shaft assembly in a suitable press. Press on the end of the axle shaft until the wheel bearing and brake assembly is removed.

## AXLE SHAFT ASSEMBLY

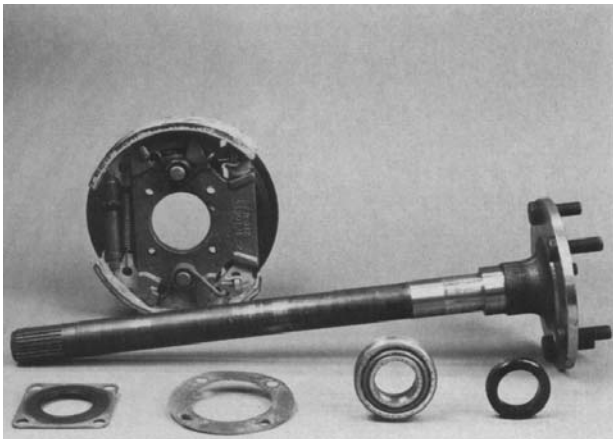

1. Inspect the shaft for possible damage. In the following order, place new oil seal, brake assembly, new grease packed bearing assembly (with unit bearing rib ring toward fanged end of shaft) on the axle shaft. The retaining ring will be placed on the shaft later.

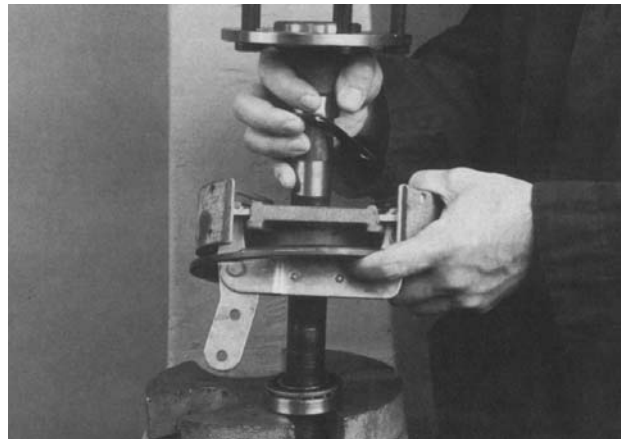

2. Support the bearing assembly in a suitable press.

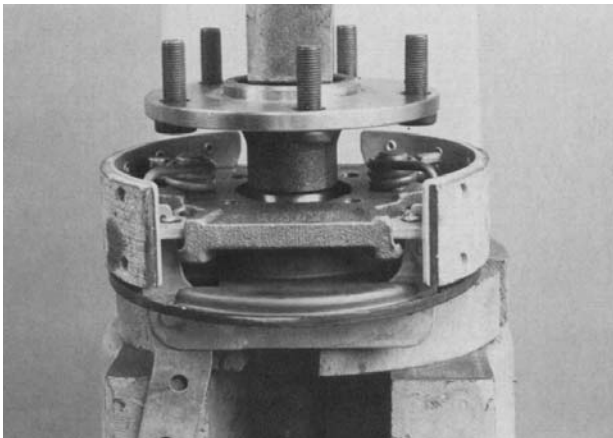

3. Press assembly until bearing is firmly seated against axle shaft shoulder.

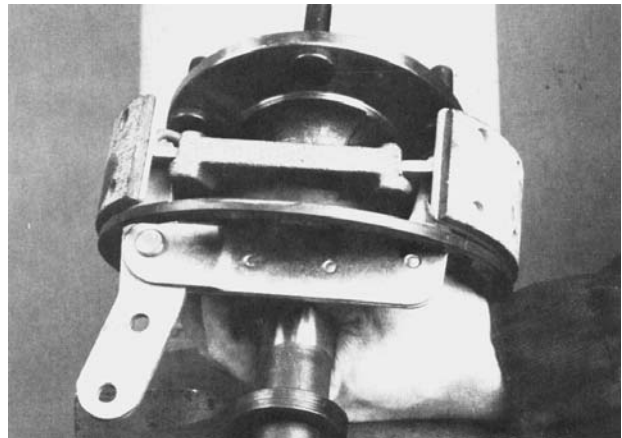

4. Slide new retaining ring on the axle shaft and support the shaft in suitable press.

## AXLE SHAFT ASSEMBLY (CONTINUED)

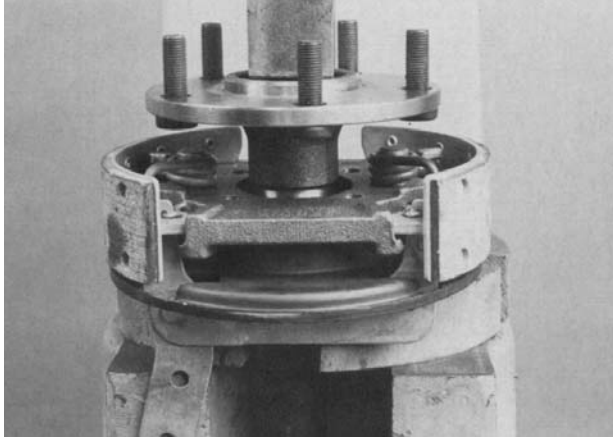

5. Press the retaining ring firmly against bearing.

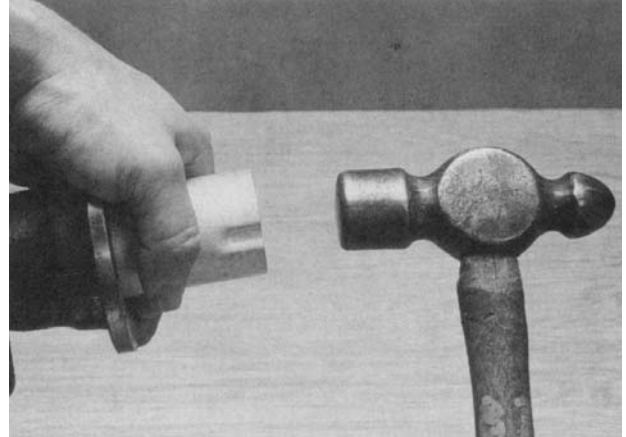

6. Assemble new grease seal into housing to original depth. After seal has been assembled, grease lip of seal.

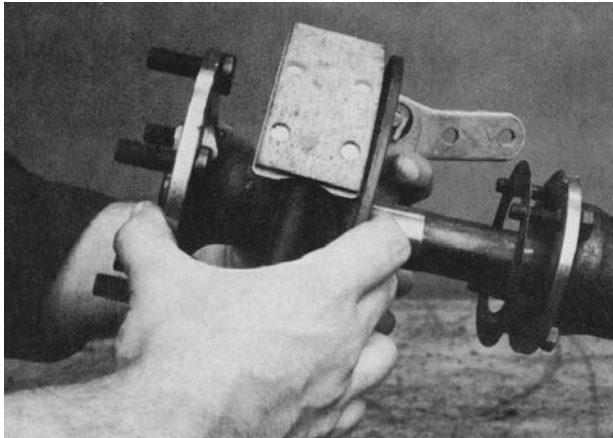

7. Assemble bearing retainer bolts and new gasket on axle housing. Then install axle shaft assembly into axle housing. Care should be taken not to damage gasket, oil seal, and bearing. Line up holes of brake assembly and oil seal. Push axle shaft as far as possible into axle housing.

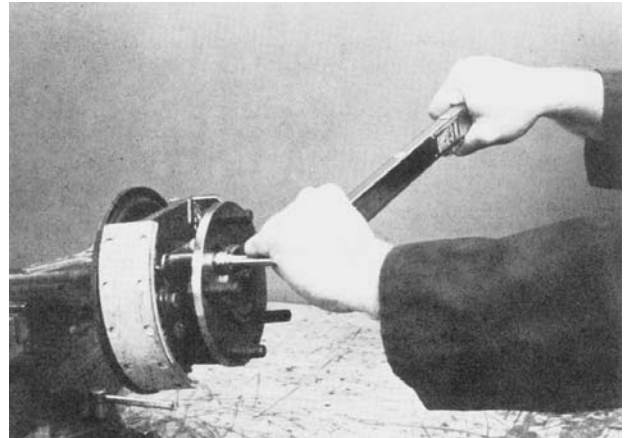

8. Start nuts on bolts by hand. Tighten nuts in a manner that assures the seal and bearing assembly are drawn evenly into axle housing. Use a torque wrench and torque nuts to 16-20 ft/lb (21-27Nm)

# SERVICE CHART



Before servicing or making adjustments to the machine, stop engine, set park brak and remove key from ignition.



Follow all procederes and ONLY use parts prescribed by the manufacturer. Read the engine manual before maintenance.

	Daily	As Required	100 Hours	200 Hours	250 Hours	300 Hours	400 Hours	Every 500 Hours/Yearly
§ Engine Oil	C		R	R		R	R	R
§ Engine Oil Filter				R			R	R
Engine for Leaks and Loose Parts	C		C	C		C	C	C
¤ Air Cleaner (Paper Element)		C	C	C		C	C	R
¤ Pre-Cleaner (Every 25 hours)		C	C	C	C	C	C	R
‡ Spark Plugs		R		C			C	R
Idle Speed					C			C
£ Air Cooling System		C	C	C		C	C	C
Belts and Hoses	C				C			C
* Tire Pressure	C		C	C		C	C	C
Fuel Level	C	C						
Fuel Filter		R						R
Hydraulic Oil	C		C	C		C	C	R
Hydraulic Oil Filter					R			R
Hydraulic System for Leaks and Loose Parts	C		C	C		C	C	C
Battery Electrolyte Level			C	C		C	C	C
Clean Battery Terminals					C			C
† Torque Lug Nuts				C			C	C
Rear Axle Gear Lube			C	C		C	C	C
Lubricate			C	C		C	C	C
Flush Spray Systems Water/Chemical Tanks	C	C						

C=Check or Clean at specified intervals

R=Replace at specified intervals

\* Tire pressure: Front 20 psi (1.4 bar), Rear 18 psi (1.3 bar)

† Torque tire nuts after the first 10 hours and every 200 hours there after (64 to 74 ft/lb (87-100 Nm))

§ Change oil after first 5 hours.

¤ Clean more often under dusty conditions or when airborne debris is present, replace air cleaner parts, if very dirty.

£ Remove cooling shrouds and clean cooling areas more frequently under extremely dusty, dirty conditions.

‡ Gap 0.40 (1.02 mm) Torque to 18-22 ft/lb (24.4-29.8 Nm)

The suggested maintenance checklist is not offered as a replacement for the manufacturer's engine manual but as a supplement. You must adhere to the guidelines established by the manufacturer for warranty coverage. In adverse conditions such as dirt, mud or extreme temperatures, maintenance should be more frequent.

# END USER'S SERVICE CHART

	Daily	As Required	100 Hours	200 Hours	250 Hours	300 Hours	400 Hours	Every 500 Hours/Yearly
§ Engine Oil								
§ Engine Oil Filter								
Engine for Leaks and Loose Parts								
α Air Cleaner (Paper Element)								
α Pre-Cleaner (Every 25 hours)								
‡ Spark Plugs								
Idle Speed								
£ Air Cooling System								
Belts and Hoses								
* Tire Pressure								
Fuel Level								
Fuel Filter								
Hydraulic Oil								
Hydraulic Oil Filter								
Hydraulic System for Leaks and Loose Parts								
Battery Electrolyte Level								
Clean Battery Terminals								
† Torque Lug Nuts								
Rear Axle Gear Lube								
Lubricate								
Flush Spray Systems Water/Chemical Tanks								

**C=Check or Clean at specified intervals**

**R=Replace at specified intervals**

**\* Tire pressure: Front 20 psi (1.4 bar), Rear 18 psi (1.3 bar)**

**† Torque tire nuts after the first 10 hours and every 200 hours there after (64 to 74 ft/lb (87-100 Nm))**

**§ Change oil after first 5 hours.**

**α Clean more often under dusty conditions or when airborne debris is present, replace air cleaner parts, if very dirty.**

**£ Remove cooling shrouds and clean cooling areas more frequently under extremely dusty, dirty conditions.**

**‡ Gap 0.40 (1.02 mm) Torque to 18-22 ft/lb (24.4-29.8 Nm)**

## ADJUSTMENTS

### INTERLOCK SWITCH

Located on the front, below the floorboard and behind the clutch. The Interlock Switch is in the electrical circuit between the starter solenoid and the starter on the ignition switch. When the clutch pedal is depressed, it pushes the plunger on the interlock switch in, which creates a circuit. Thus allowing the engine to start. When the clutch pedal is released the plunger on the interlock switch comes out, which breaks the circuit. To adjust, loosen the two nuts holding the interlock switch and move the interlock switch towards or away from the clutch pedal as needed.

### HYDRAULIC POWER UNIT BELT

Located to the rear and left of the engine. Should have approximately  $\frac{1}{4}$ " (6.5 mm) of deflection in the center of the top strand. To adjust, loosen the bolt holding the hydraulic power unit bracket to the frame and adjust the belt tension as required. Retighten the bolt after the adjustments made.

### FOOT CLUTCH BELT

See belt and pulley drawing in this book. Belt retainer should be adjusted so that there is  $\frac{1}{8}$ " to  $\frac{1}{4}$ " (3.25 to 6.5 mm) clearance between the belt and retainer with the clutch fully engaged. This is just a starting point. Start the engine with the transmission in neutral and the park brake set. Engage and disengage the clutch, check to see if the belt has stopped and is against the retainers. If not shut engine off and readjust the retainers. Adjust the clutch rods as required to shorten, turn the ball joints in and out to lengthen.

### SPRAY PUMP WITH ELECTRIC CLUTCH BELT

Located to the rear and left of the engine. Should have approximately  $\frac{1}{2}$ " (13 mm) of deflection in the center of the top strand. Loosen and tighten the  $\frac{3}{8}$  - x  $2\frac{1}{2}$  set screw located on the frame pushing against the pump arm.

### PARK BRAKE

Adjust on lever. Adjust on clevis.

### BRAKES

Can be adjusted from outside of brake drum with a brake tool.

### SPEED CALIBRATION NUMBERS

The speed calibration number for the Spray Star 1602 is 114. This is measured off the drive shaft.

The speed calibration number for the Spray Star 1607 is 621. This is measured off the drive shaft.

## STORAGE

If the engine will be out of service for two or more months, use the following storage procedure.

1. Clean the exterior surfaces of the engine.
2. Change the oil and filter while the engine is still warm from operation.
3. The fuel system must be completely emptied, or the gasoline must be treated with a stabilizer to prevent deterioration.

If you choose to use a stabilizer, follow manufacturers recommendations, and add the correct amount for the capacity of fuel system. Fill fuel tank with clean, fresh gasoline. Run engine for 2-3 minutes to get stabilized fuel into carburetor. Close fuel shut-off valve when unit is being stored or transported.

To empty the system, drain fuel tank and carburetor, or run engine until tank and system are empty.

4. Remove the spark plugs. Add one tablespoon of engine oil into each spark plug hole. Install plugs, but do not connect the plug leads. Crank the engine two or three revolutions.
5. Store machine in a clean, dry place.



# HYDRAULIC DIAGRAM

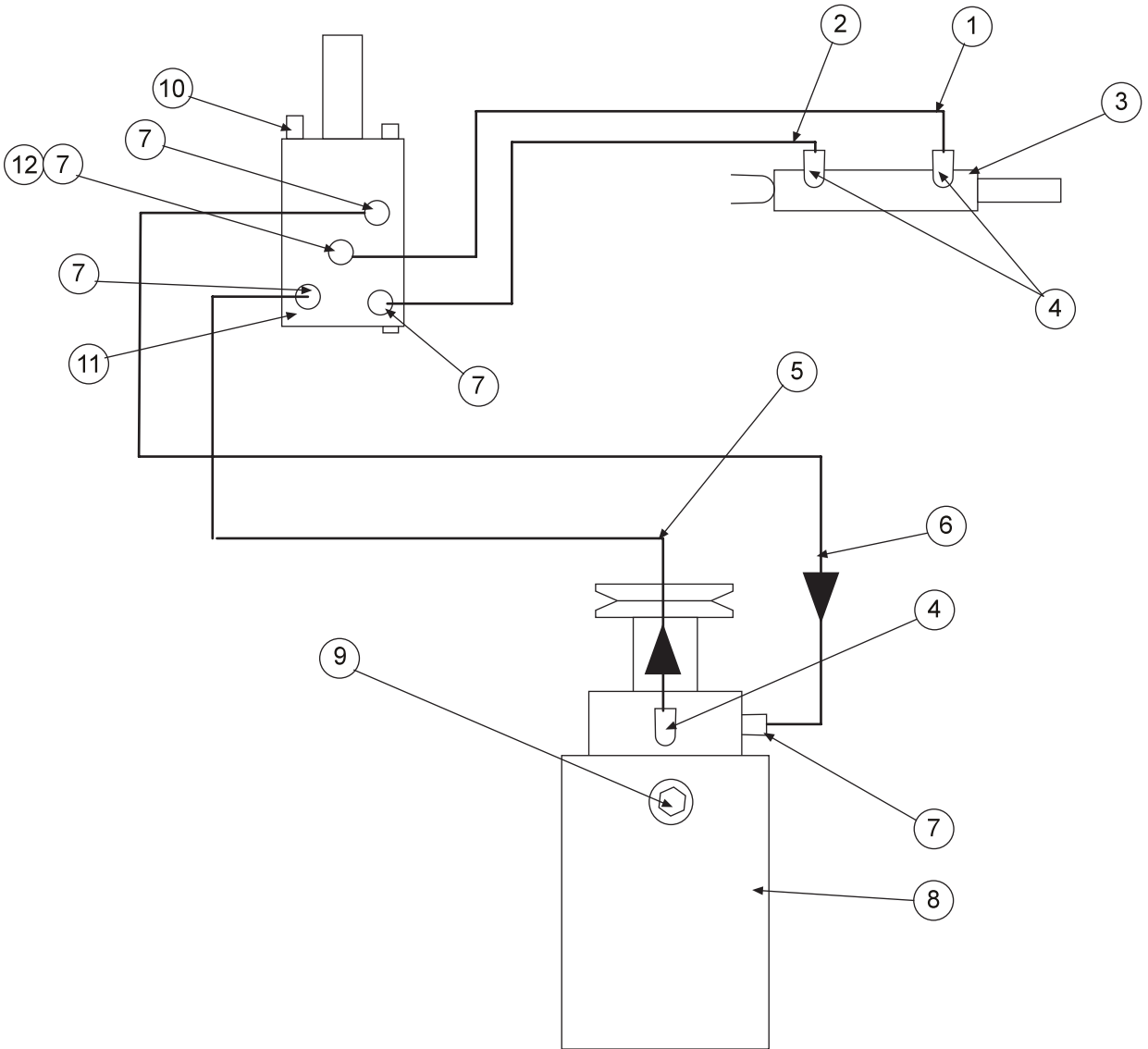

Diagrams



## HYDRAULIC DIAGRAM PARTS LIST

REF#	PART#	DESCRIPTION	QUANTITY
1	14-352	Hydraulic Hose 54"	1
2	14-351	Hydraulic Hose 46"	1
3	50-456	Hydraulic Cylinder 1 1/2 x 7	1
	14-267	Seal Kit	
4	18-171	1 1/16 X 9/16 90° Straight Thread Elbow	3
5	14-355	Hydraulic Hose 81"	1
6	14-354	Hydraulic Hose 84"	1
7	18-306	1 1/16 X 9/16 Straight Thread Connector	5
8	15-315	Hydraulic Power Unit	1
	15-315-01	Repair Kit	
9	27-059	Filler Breather (part of 15-315)	1
	18-314	3/8 Pipe Coupler	1
	18-287	3/8 Pipe Nipple x 2	1
10	HBM-6-16	Metric Bolt M6 - 1 x 16	4
	HWLM-6	Lockwasher M6	4
11	15-301	Orbitor	1
	15-301-01	Seal Kit	
12	18-309	Swivel Nut	1

## FITTING TORQUE CHARTS

Seal-Lok Straight and Adjustable Fitting (Steel) Torque Ratings				
Fitting Size	SAE Tube Thread Size	Tube Side		Port Side
		in. lbs.	ft. lbs.	ft. lbs.
4	9/16 - 18	220	18	15
6	1 1/16 - 16	360	30	35
8	1 3/16 - 16	480	40	60
10	1-14		60	100
12	1 3/16 - 12		85	135
14	1 5/16 - 12		95	175
16	1 7/16 - 12		110	200
20	1 11/16 - 12		140	250
24	2 - 12		180	305
32	2 1/2 - 12		360	375

**Over tightened fittings will result in crushing the cone which will create a leak.**

**Charts Developed by Parker Henniphin**

# WIRING DIAGRAM

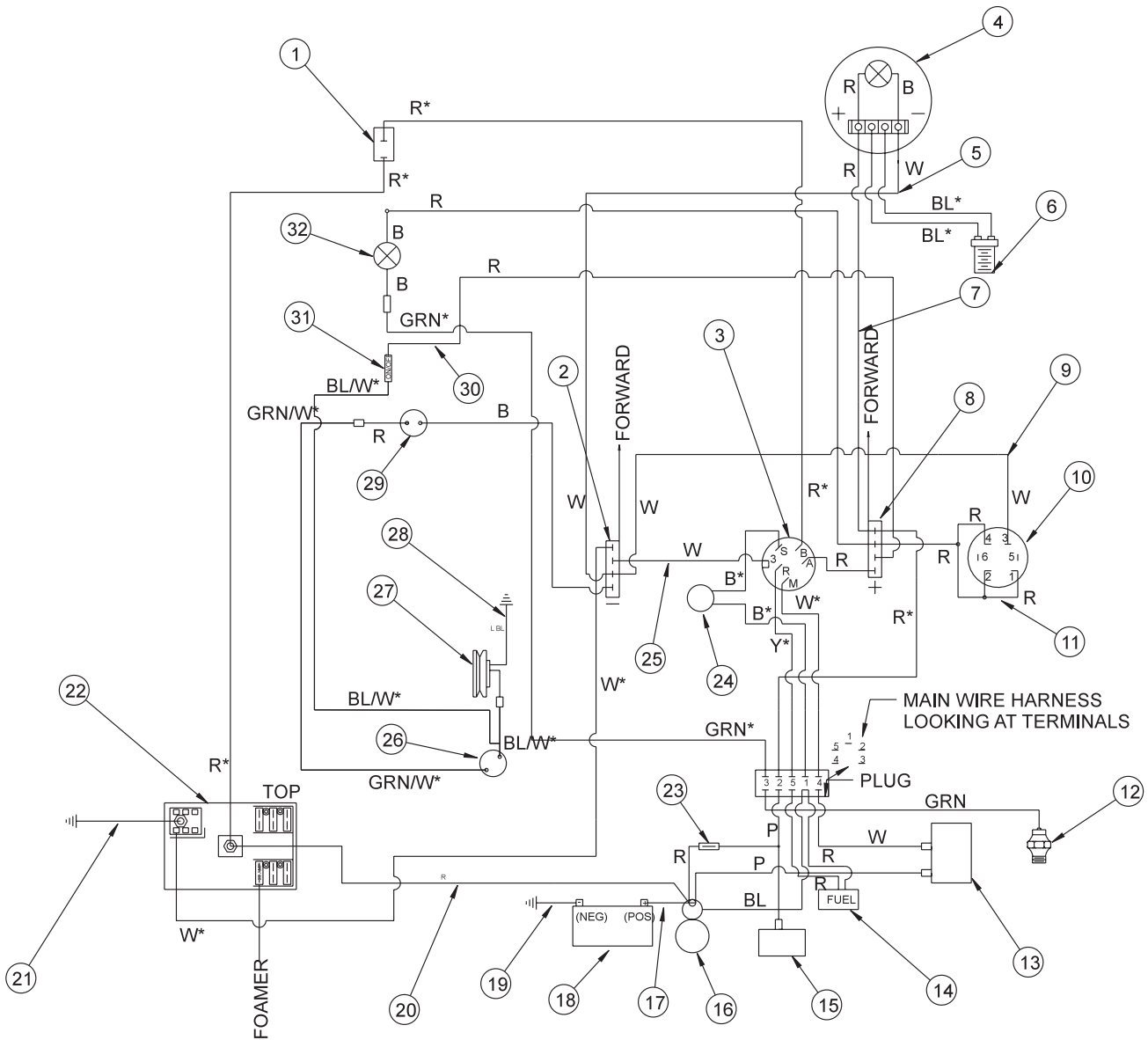

**NOTE:**

Use dielectric grease on all electrical connections.

To reset circuit breaker on ball valve, you must disconnect power to the computer.

**FUSES**

Boom Lift	30 AMP	33-273
Spray System	15 AMP	33-508
Manifold Valve	5 AMP	33-284
Foamer	10 AMP	33-507
Hose Reel	30 AMP	33-273

**Color Code Chart**

Bl	Blue
Br	Brown
Y	Yellow
Grn	Green
O	Orange
R	Red
B	Black
P	Purple
W	White
G/W	Green & White

# WIRING DIAGRAM PARTS LIST

REF#	PART#	DESCRIPTION	QUANTITY
1	34-146	Panel Mounted Circuit Breaker	1
	34-145	Circuit Breaker Boot	1
2	8935	Buss Bar (-)	1
3	13-288	Ignition Switch (Kohler 25 099 04)(part of engine)	1
	76-310	Key Set	1
4	16-882	Speedometer	1
	8854	Fork Terminal	2
	8963	Heat Shrink	2
5	14-332	Speedometer Ground Wire	1
6	16-883	Magnetic Sensor	1
7	14-333	Speedometer B+ Wire	1
8	8935	Buss Bar(+)	1
9	14-331	Hour / Voltmeter Ground Wire	1
10	12-017	Hourmeter	1
11	14-330	Hour / Voltmeter B+ Wire	1
12		Oil Sender (part of engine)	
13		Ignition Module (part of engine)	
14		Fuel Shut-Off Solenoid (part of engine)	
15		Rectifier (part of engine)	
16		Starter (part of engine)	
17	50-323	Red Battery Cable	1
18	33-216	Battery	1
19	22-054	Ground Battery Cable	1
20	15-484	Wire Assembly Fuse Block To + Bat. (on solenoid)	1
21	15-485	Wire Assembly Fuse Block To Ground	1
22	33-271	Fuse Block	1
23		Wire With Fuse (part of engine)	
		Fuse AGC 30	
24	22-002	Interlock Switch	1
25	14-334	Ignition Switch Ground Wire	1
26	33-480	Pressure Switch	1
27	16-994	Hypro Pump With Electric Clutch	1
	8958	Male Slide on Terminal	1
	8963	Heat Shrink	1
28	15-457	Ground Wire	1
29	77-207	Buzzer	1
	8849-3	Black Wire	1
	8860	String Connector	1
	8859	Ring Terminal <sup>3</sup> / <sub>16</sub>	1
	8853	Slide On Connector	1
	8963	Heat Shrink	2
30	14-335	Spray Pump Switch B+ Wire	1
31	15-314	Toggle Switch	1
	15-472	Switch Boot	1
32	50-359	Oil Warning Light	1
	8850-12	Red Wire	1
	8860	String Connector	1
	8859	Ring Terminal <sup>3</sup> / <sub>16</sub>	1
	8958	Male Slide On Terminal	1
	8963	Heat Shrink	2
N.S.	22-017	Cable Black (transmission to frame)	1
	14-336	Main Wire Harness (Includes all wire colors with *)	1

# BODY & FRAME DRAWING

Parts

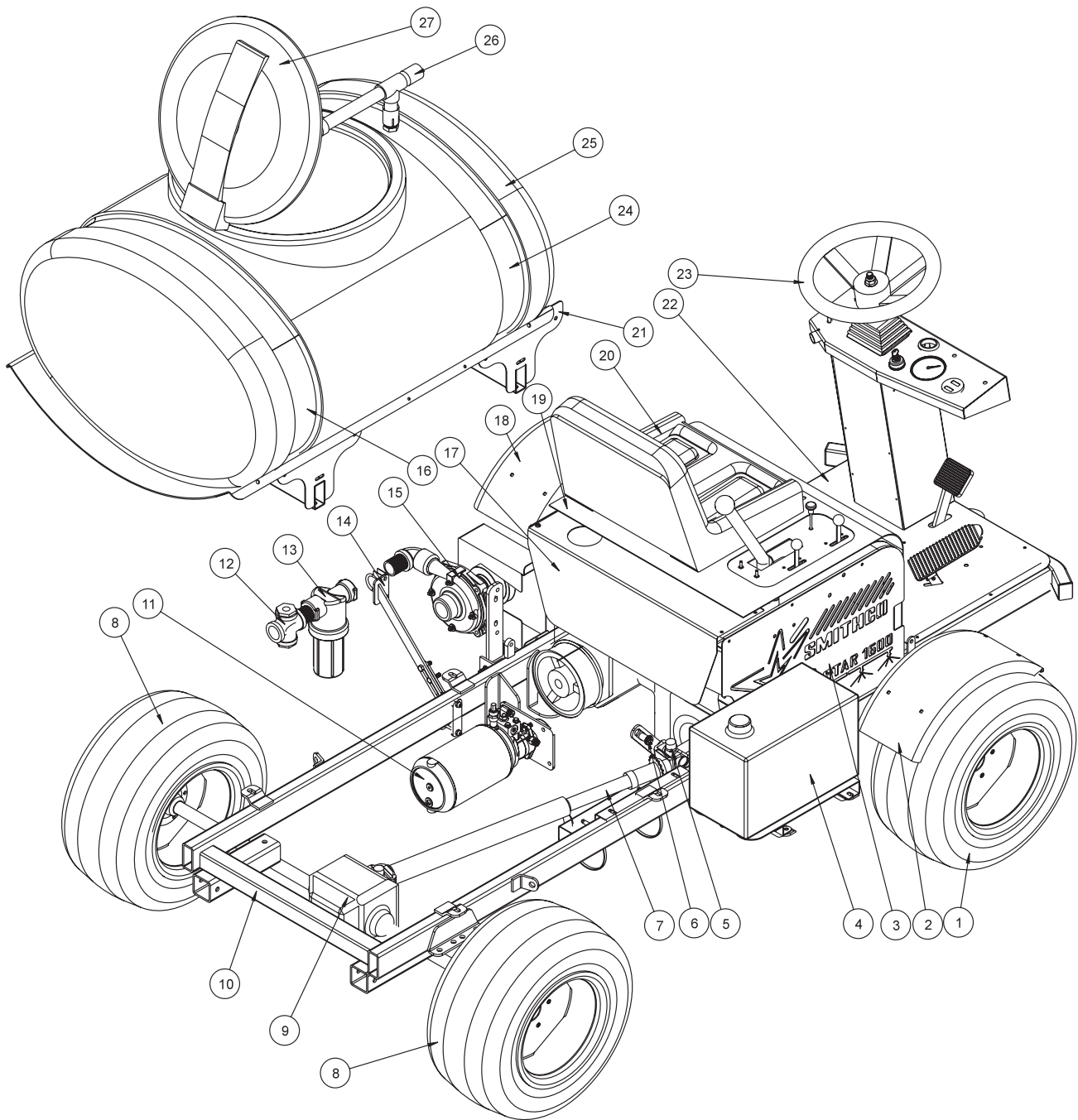

## BODY & FRAME PARTS LIST

REF#	PART#	DESCRIPTION	QUANTITY
1	16-857	Front Tire & Wheel	2
	16-857-01	Tire 20 x 10.00 - 10NHS 4 Ply	2
	16-857-02	Wheel	2
	HNL-12-20	Lug Nut $\frac{1}{2}$ - 20	10
2	10-180	Front Fender	1
3	14-350	Right Side Panel	1
	14-349	Left Side panel	1
4	15-491	5 Gallon Gas Tank	1
	15-492	Cap with Gauge	1
5	15-182	Cross (part of 14-370)	2
	16-024	U-Bolt Kit	4
	HWL-516	Lockwasher $\frac{5}{16}$ (part of 16-024)	8
	HN-516-24	Nut $\frac{5}{16}$ - 24 (part of 16-024)	8
6	16-883	Magnetic Sensor	1
7	14-370	Driveline (complete)	1
8	16-225	Rear Tire & Wheel	2
	16-225-01	Tire 24 x 13.00 - 12NHS 4 Ply	2
	16-225-02	Wheel	2
	HNL-716-20	Lug Nut $\frac{7}{16}$ - 20	10
9	16-037	Axle with Brakes	1
10	14-353	Main Frame	1
11	15-315	Hydraulic Power Unit	1
	15-315-01	Repair Kit	1
12	18-259	Cross $1\frac{1}{4}$	1
13	14-371	Strainer	1
14	15-521	Top Filter Bracket	1
15	16-998	Hypro® Pump	1
16	14-322	Rear Tank Strap	1
17	14-326	Rear Engine Cover	1
18	10-180	Front Fender	1
19	15-356	Engine Cover/Seat	1
20	14-270	Seat with Adjusters	1
21	14-321	Tank Carrier	1
22	14-328	Floorboard	1
23	13-718	Steering Wheel	1
	13-726	Steering Wheel Cap	1
24	14-327	Front Tank Strap	1
25	14-451	160 Gallon Poly Tank	1
26	14-365	Air Gap Filler	1
27	16-953	16" Hinged Lid/Well with Gasket (part of tank)	1
	16-953-01	Gasket (for 16-953)	1
	16-169	Strainer Basket 16"	1

# TANK AND REAR FENDER DRAWING

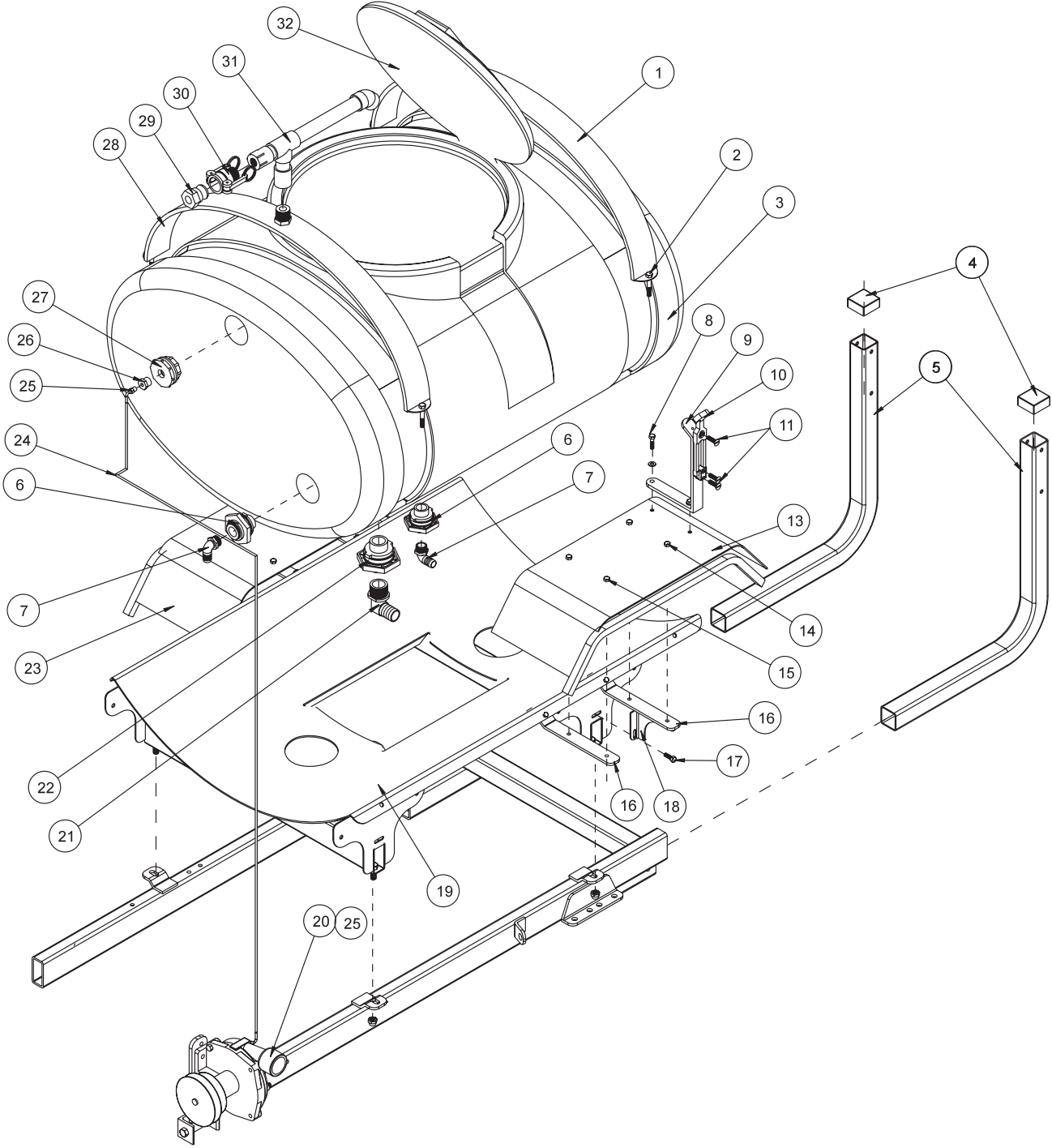

Parts

## TANK AND REAR FENDER PARTS LIST

REF#	PART#	DESCRIPTION	QUANTITY
1	14-322	Rear Tank Strap	1
2	HB-38-16-250	Bolt $\frac{3}{8}$ - 16 x $2\frac{1}{2}$	4
	HNTL-38-16	Lock Nut $\frac{3}{8}$ - 16	4
3	14-451	160 Gallon Poly Tank	1
4	16-557	Square Cap	2
5	14-325	Boom Carrier	2
6	16-150	Double Threaded Fitting $\frac{3}{4}$ (bottom fitting only part of tank)	2
7	16-155	Elbow $\frac{3}{4}$ MPT x 1 HB	2
8	HB-516-18-125	Bolt $\frac{5}{16}$ - 18 x $1\frac{1}{4}$	4
	HW-516	Washer $\frac{5}{16}$	4
	HWL-516	Lockwasher $\frac{5}{16}$	4
	HN-516-18	Nut $\frac{5}{16}$ -18	4
9	15-328	Boom Carrier	2
10	15-437	Latch	2
11	HSM-8-32-150	Machine Screw #8 - 32 x $1\frac{1}{2}$	6
	HWL-8	Lockwasher #8	6
	HN-8-32	Nut #8 -32	6
13	15-447	Left Fender	1
14	HB-516-18-075	Bolt $\frac{5}{16}$ - 18 x $\frac{3}{4}$	6
	HNTL-516-18	Lock Nut $\frac{5}{16}$ - 18	6
15	HB-516-18-100	Bolt $\frac{5}{16}$ - 18 x 1	2
	HNTL-516-18	Lock Nut $\frac{5}{16}$ -18	2
16	14-324	Fender Mount	4
	HB-14-20-075	Bolt $\frac{1}{4}$ - 20 x $\frac{3}{4}$	4
	HNTL-14-20	Lock Nut $\frac{1}{4}$ - 20	4
17	HB-516-18-100	Bolt $\frac{5}{16}$ - 18 x 1	2
	HNTL-516-18	Lock Nut $\frac{5}{16}$ - 18	2
	HW-516	Washer $\frac{5}{16}$	as needed
18	14-341	Left Fender Brace	1
	14-340	Right Fender Brace	1
19	14-321	Tank Carrier	1
20	16-998	Hypro® Pump	1
21	16-156	Elbow $1\frac{1}{4}$ MPT x $1\frac{1}{4}$ HB	1
22	16-194	Anti Vortex Fitting $1\frac{1}{4}$ (part of tank)	1
23	15-446	Right Fender	1
24	8954-26	Clear Hose $\frac{3}{16}$ ID	1
25	33-494	Elbow $\frac{1}{8}$ MPT x $\frac{3}{16}$ HB	2
26	33-496	Reducer Bushing $\frac{1}{2}$ MPT x $\frac{1}{8}$ FPT	1
27	33-495	Bulkhead Fitting	1
28	14-327	Front Tank Strap	1
29	16-961	Aluminum Adapter 1" Female thread	1
30	16-962	Aluminum Coupler 1" Male Thread	1
	16-962-01	1" Buna-N Gasket (part of 16-962)	1
31	14-365	Air Gap Filler	1
32	16-953	16" Hinged Lid/Well with Gasket (part of tank)	1
	16-953-01	Gasket (for 16-953)	1
	16-169	Strainer Basket (not included with tank)	1

# NOSE CONE DRAWING

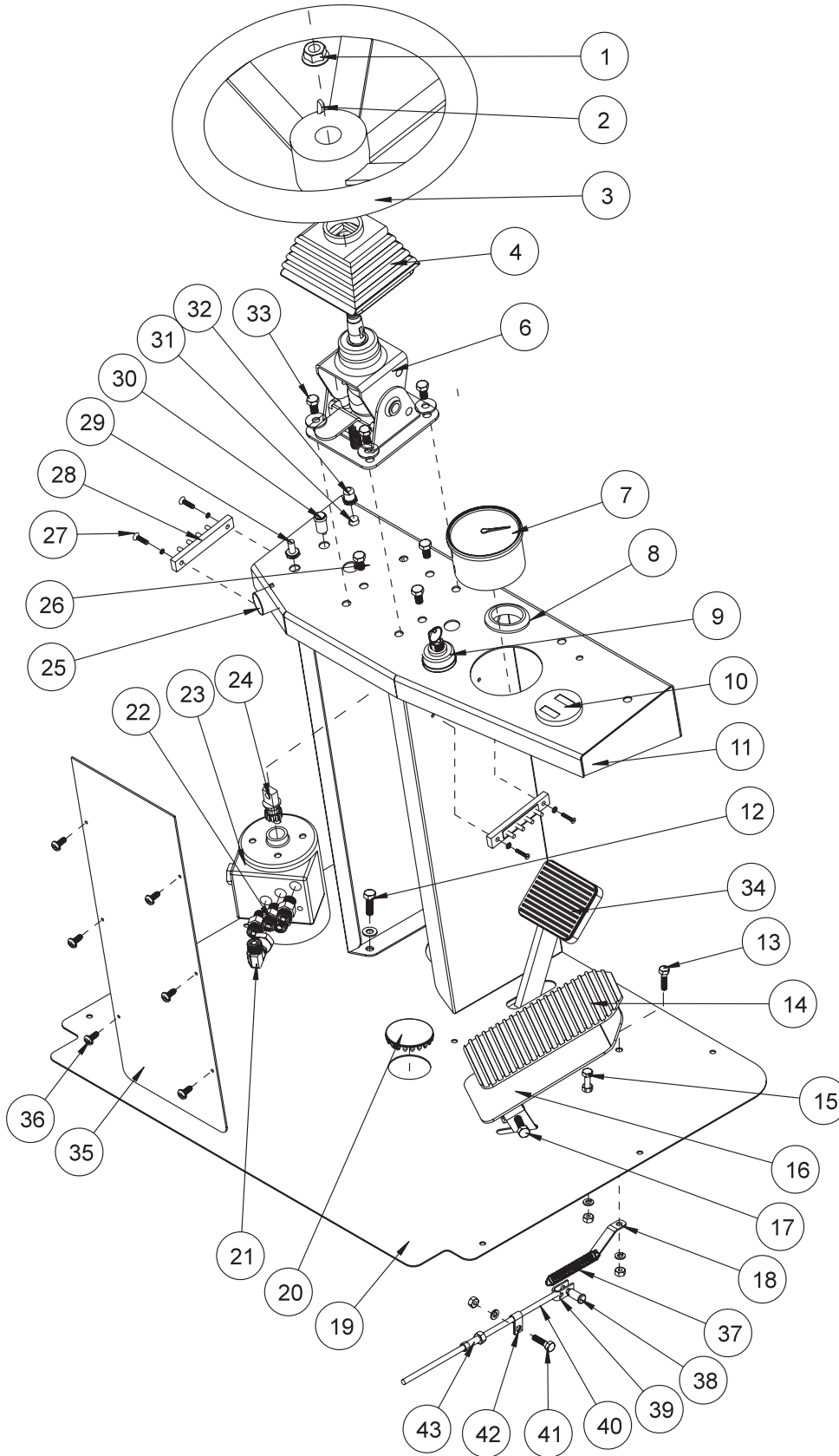

Parts



## NOSE CONE PARTS LIST

REF#	PART#	DESCRIPTION	QUANTITY
1	HNJ-58-18	Jam Nut <sup>5</sup> / <sub>8</sub> - 18	1
2	HWK-316-075	Woodruff Key <sup>3</sup> / <sub>16</sub> x <sup>3</sup> / <sub>4</sub>	1
3	13-718	Steering Wheel	1
	13-726	Steering Wheel Cap	
4	76-364	Black Boot	1
6	76-362	Mini Tilt Steering	1
7	16-882	Speedometer (see wiring for terminals)	1
8	50-400	Rubber Grommet	1
9	13-288	Key Switch (Kohler 25 099 04)(part of engine)	1
	76-310	Set of Keys	1
10	12-017	Hourmeter	1
11	14-329	Console	1
	14-346	Decal, Console	1
	8803-8	Black Trim with Lace	2
12	HB-516-18-100	Bolt <sup>5</sup> / <sub>16</sub> - 18 x 1	4
	HW-516	Washer <sup>5</sup> / <sub>16</sub>	4
	HWL-516	Lockwasher <sup>5</sup> / <sub>16</sub>	4
	HN-516-18	Nut <sup>5</sup> / <sub>16</sub> - 18	4
13	HB-14-20-100	Bolt <sup>1</sup> / <sub>4</sub> - 20 x 1	1
	HWL-14	Lockwasher <sup>1</sup> / <sub>4</sub>	1
	HN-14-20	Nut <sup>1</sup> / <sub>4</sub> - 20	1
14	15-459	Pedal Pad	1
15	HB-14-20-250	Bolt <sup>1</sup> / <sub>4</sub> - 20 x 2 <sup>1</sup> / <sub>2</sub>	1
	HWL-14	Lockwasher <sup>1</sup> / <sub>4</sub>	1
	HN-14-20	Nut <sup>1</sup> / <sub>4</sub> - 20	2
16	15-336	Foot Pedal	1
17	HB-516-18-100	Bolt <sup>5</sup> / <sub>16</sub> -18 x 1	2
	HNTL-516-18	Lock Nut <sup>5</sup> / <sub>16</sub> -18	2
18	15-353	Foot Pedal Spring Bracket	1
19	14-328	Floor Board	1
	8803-16	Black Trim	1
20	25-199	2" Plug Button	1
21	18-309	<sup>3</sup> / <sub>8</sub> - 90° Swivel Nut Elbow	1
22	18-306	Straight Thread Connector	4
23	15-301	Orbital	1
24	48-187	Stub Shaft	1
25	77-207	Buzzer (see wiring for terminals)	1
26	HBM-6-1-16	Metric Bolt M6 -1 x 16	4
	HWLM-6	Metric Lockwasher M6	4
27	HSM-10-32-063	Machine Screw #10 - 32 x <sup>5</sup> / <sub>8</sub>	4
	HWL-10	Lockwasher #10	4
	HN-10-32	Nut #10 - 32	4
28	8935	Buss Bar	2
29	15-314	Toggle Switch	1
	15-472	Switch Boot	1

(Continued on next page)

# NOSE CONE DRAWING

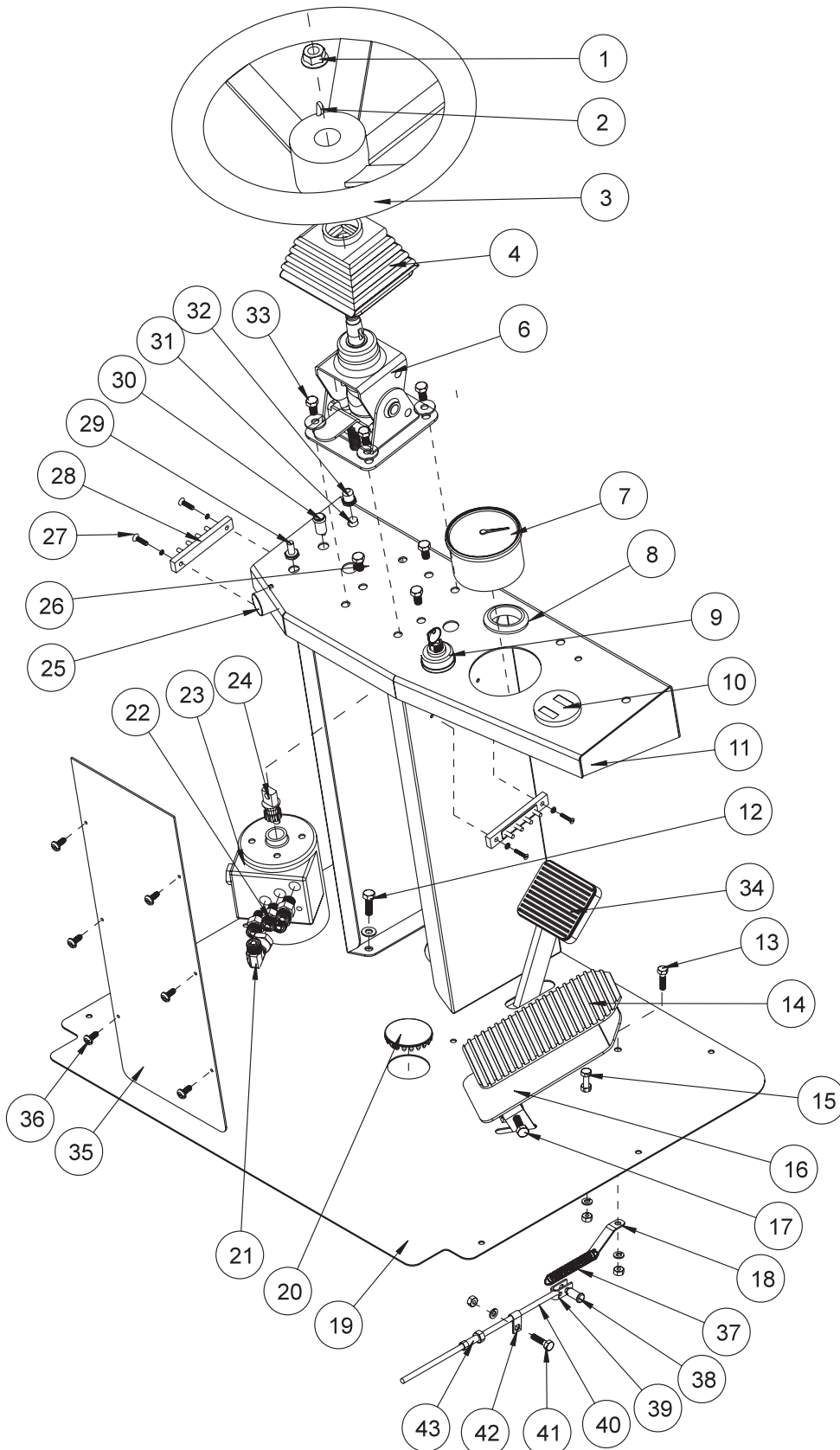

Parts

## NOSE CONE PARTS LIST

REF#	PART#	DESCRIPTION	QUANTITY
30	50-359	Warning Light (see wiring for terminals)	1
31	34-146	Circuit Breaker 30 Amp	1
32	34-145	Circuit Breaker Boot	1
33	HB-516-18-100	Bolt $\frac{5}{16}$ - 18 x 1	4
	HW-516	Washer $\frac{5}{16}$	4
	HNTL-516-18	Lock Nut $\frac{5}{16}$ - 18	4
34	15-496	Brake Pedal	1
	16-062	Pedal	1
	15-015	Pedal Pad	1
35	10-200	Tower Plate	1
36	HSA-8-075	Tapping Screw #8 x $\frac{3}{4}$	6
37	16-046	Extension Spring	1
38	HCP-14-075	Clevis Pin $\frac{1}{4}$ x $\frac{3}{4}$	1
39	17-153	Clevis	1
40	15-310	Throttle Cable	1
41	HB-14-20-100	Bolt $\frac{1}{4}$ - 20 x 1	1
	HWL-14	Lockwasher $\frac{1}{4}$	1
	HN-14-20	Nut $\frac{1}{4}$ - 20	1
42	17-154	Cable Clamp	1
43	17-155	Retainer	1
	HN-516-24	Nut $\frac{5}{16}$ - 24	2

# BRAKE DRAWING

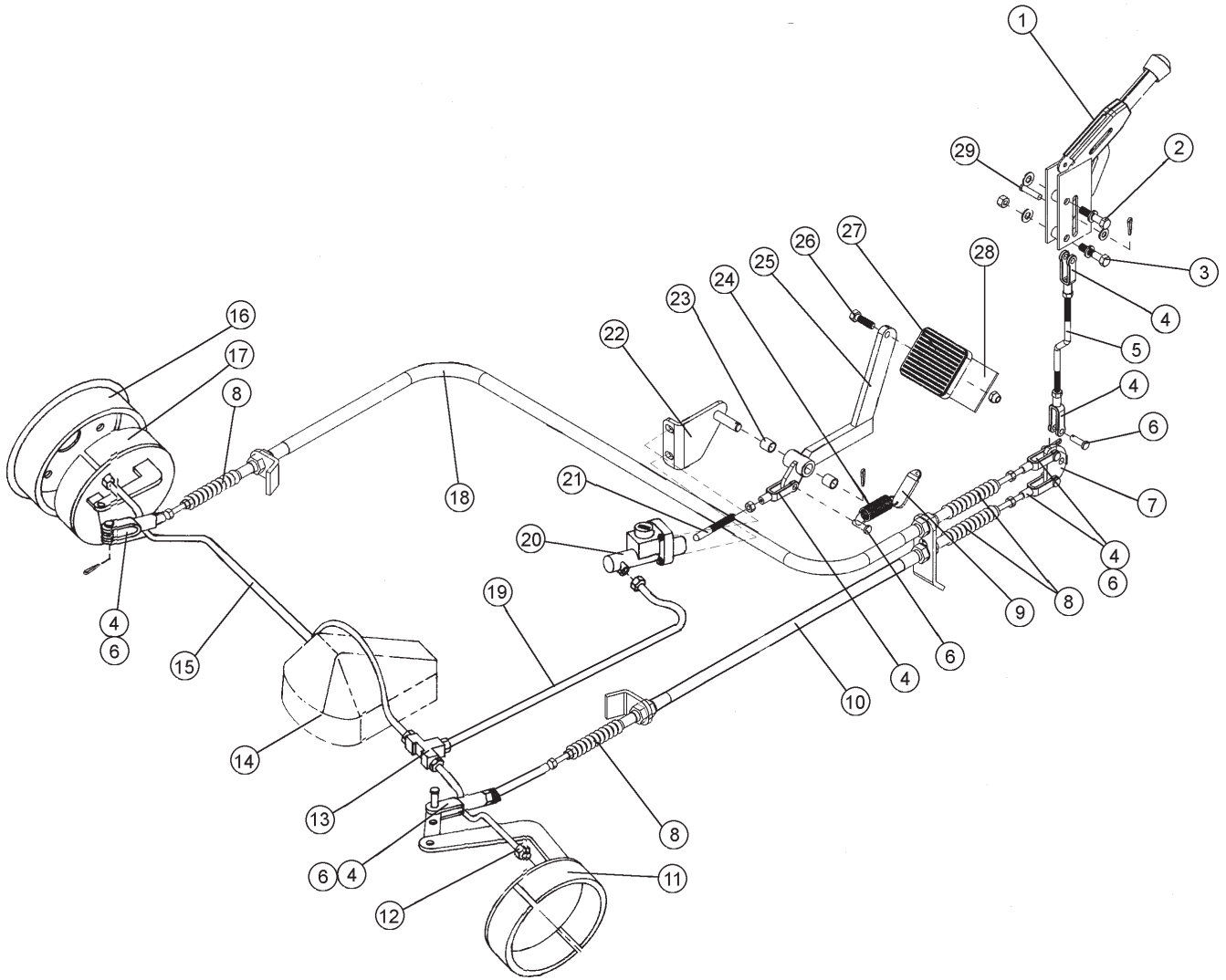

Parts

## BRAKE PARTS LIST

REF#	PART#	DESCRIPTION	QUANTITY
1	60-106	Brake Lever	1
2	HB-38-16-175	Bolt $\frac{3}{8}$ - 16 x $1\frac{3}{4}$	1
	HW-38	Washer $\frac{3}{8}$	1
	HWL-38	Lockwasher $\frac{3}{8}$	1
3	HB-38-16-175	Bolt $\frac{3}{8}$ - 16 x $1\frac{3}{4}$	1
	HW-38	Washer $\frac{3}{8}$	1
	HWL-38	Lockwasher $\frac{3}{8}$	1
	HN-38-16	Nut $\frac{3}{8}$ - 16	1
4	11-100	Yoke	7
	HN-516-24	Nut $\frac{5}{16}$ - 24	7
5	15-347	Brake Rod	1
6	HCP-516-100	Clevis Pin $\frac{5}{16}$ x 1	6
	HP-18-100	Cotter Pin $\frac{1}{8}$ x 1	6
7	15-331	Park Brake relay	1
8	60-536	Bellows	4
9	15-354	Brake Pedal Spring Bracket	1
10	14-338	Right Brake Cable	1
11	16-554	Right Brake Assembly (comes with 16-037)	1
12	16-187	Brake Line $\frac{3}{16}$ x 12 (steel)	1
13	18-089	Tee	1
14	16-037	Rear Axle	1
15	16-188	Brake Line $\frac{3}{16}$ x 34 (steel)	1
16	16-559	Brake Drum (comes with 16-037)	2
17	16-514	Left Brake Assembly (comes with 16-037)	1
18	14-339	Left Brake Cable	1
19	15-312	Brake Line $\frac{3}{16}$ x 84	1
20	50-123	Brake Cylinder	1
	50-123-01	Cap Master Cylinder	1
	50-123-02	Brake Master Cylinder Kit	1
	HB-38-16-125	Bolt $\frac{3}{8}$ - 16 x $1\frac{1}{4}$	2
	HNTL-38-16	Lock Nut $\frac{3}{8}$ - 16	2
21	16-060	Brake Rod	1
22	15-497	Brake Bracket	1
	HB-38-16-150	Bolt $\frac{3}{8}$ - 16 x $1\frac{1}{2}$	2
	HNTL-38-16	Lock Nut $\frac{3}{8}$ - 16	2
	HP-18-100	Cotter Pin $\frac{1}{8}$ x 1	1
23	20-019	Bushing (comes with 15-496)	2
24	11-050	Extension Spring	1
25	15-496	Brake Pedal	1
26	HB-38-16-100	Bolt $\frac{3}{8}$ - 16 x 1	1
	HNTL-38-16	Lock Nut $\frac{3}{8}$ - 16	1
27	15-015	Pedal Pad	1
28	16-062	Pedal	1
29	HCP-516-125	Clevis Pin $\frac{5}{16}$ x $1\frac{1}{4}$ (comes 60-106)	1
	HP-18-100	Cotter Pin $\frac{1}{8}$ x 1	1
	HW-516	Washer $\frac{5}{16}$	1

# PUMPS AND EXHAUST DRAWING

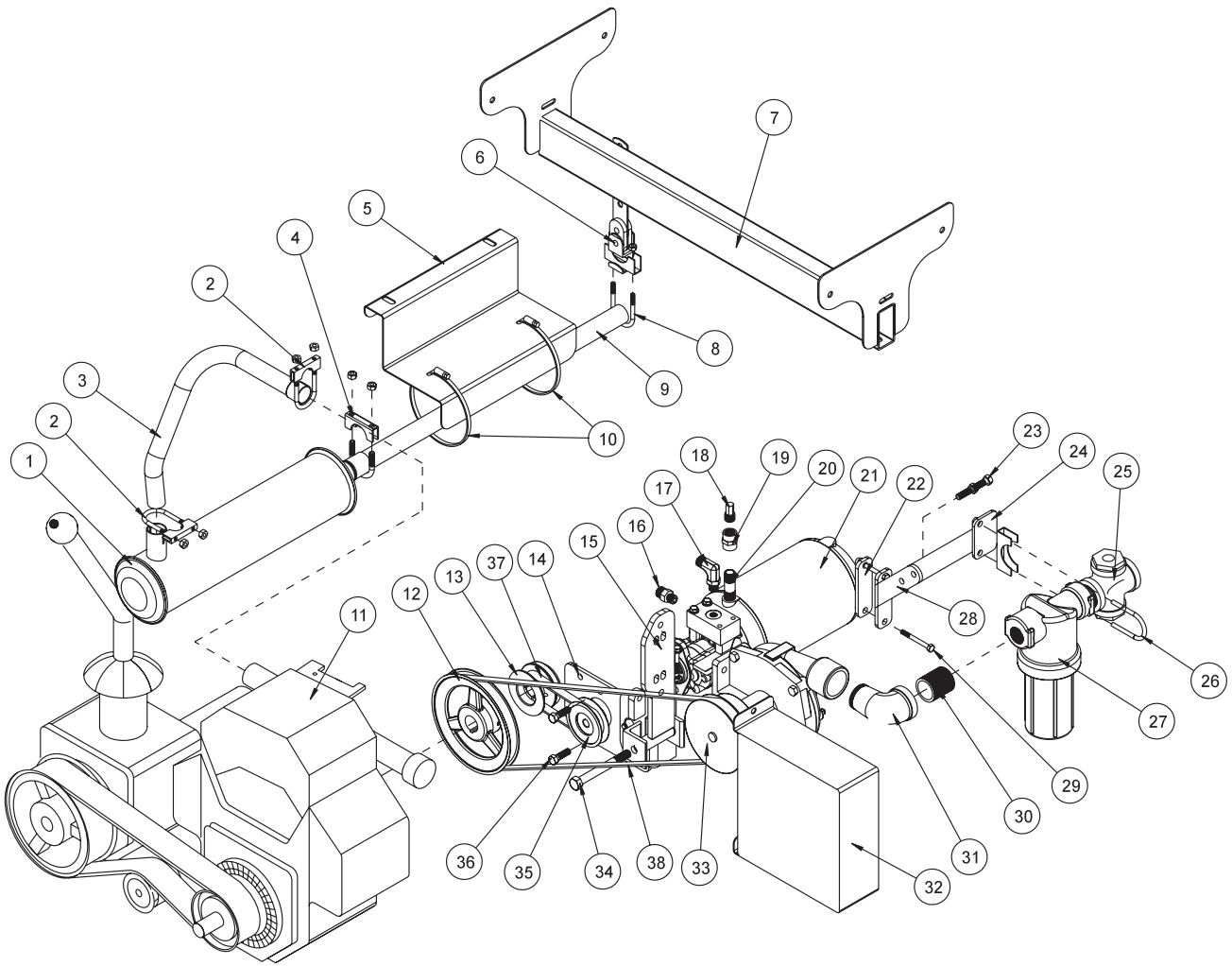

Parts

## PUMPS AND EXHAUST PARTS LIST

REF#	PART#	DESCRIPTION	QUANTITY
1	15-371	Muffler	1
2	13-498	Muffler Clamp 1 <sup>1</sup> / <sub>8</sub>	2
3	15-379	Exhaust Pipe	1
4	18-220	Muffler Clamp 1 <sup>1</sup> / <sub>4</sub>	1
5	15-386	Muffler Bracket	1
6	33-159	Universal Exhaust Hanger	1
	HSDPS-14-100	Pan Head Drill Screw SS 1 <sup>1</sup> / <sub>4</sub> x 1	1
7	14-321	Tank Carrier	1
8	50-111	Muffler Clamp 1 <sup>1</sup> / <sub>2</sub>	1
9	15-387	Tail Pipe	1
10	18-147	Hose Clamps	2
11	15-373	Engine Kohler Command 20 hp	1
	15-373-01	Exhaust Manifold (Kohler 24 164 11)	1
12	15-316	Pulley BH72 x 1 <sup>1</sup> / <sub>8</sub>	1
	HSSHS-516-50	Socket Head Set Screw <sup>5</sup> / <sub>16</sub> x 1 <sup>1</sup> / <sub>2</sub>	2
	HKSQ-14-150	Machine Key 1 <sup>1</sup> / <sub>4</sub> x 1 <sup>1</sup> / <sub>4</sub> x 1 <sup>1</sup> / <sub>2</sub>	1
13	15-318	Pulley with Hub BK30H 1 <sup>1</sup> / <sub>8</sub>	1
	HKSQ-14-150	Machine Key 1 <sup>1</sup> / <sub>4</sub> x 1 <sup>1</sup> / <sub>4</sub> x 1 <sup>1</sup> / <sub>2</sub>	1
	HB-14-20-075	Bolt 1 <sup>1</sup> / <sub>4</sub> - 20 x <sup>3</sup> / <sub>4</sub>	2
14	15-344	Pump Mount Plate	1
	HBC-38-16-125	Carriage Bolt <sup>3</sup> / <sub>8</sub> - 16 x 1 <sup>1</sup> / <sub>4</sub>	2
	HWL-38	Lockwasher <sup>3</sup> / <sub>8</sub>	2
	HN-38-16	Nut <sup>3</sup> / <sub>8</sub> - 16	2
15	15-580	Pump Arm	1
16	18-306	<sup>11</sup> / <sub>16</sub> x <sup>9</sup> / <sub>16</sub> Straight Thread Connector	1
17	18-171	<sup>11</sup> / <sub>16</sub> x <sup>9</sup> / <sub>16</sub> 90° Straight Thread Elbow	1
18	27-059	Filler Breather (part of 15-315)	1
19	18-314	<sup>3</sup> / <sub>8</sub> Coupler	1
20	18-287	<sup>3</sup> / <sub>8</sub> Pipe Nipple x 2	1
21	15-315	Hydraulic Power Unit	1
	15-315-01	Repair Kit	1
	HWK-18-063	Woodruff Key 1 <sup>1</sup> / <sub>8</sub> x <sup>5</sup> / <sub>8</sub>	1
22	15-465	Rear Mount Plate	1
23	HB-38-16-125	Bolt <sup>3</sup> / <sub>8</sub> - 16 x 1 <sup>1</sup> / <sub>4</sub>	2
	HW-38	Washer <sup>3</sup> / <sub>8</sub>	2
	HNTL-38-16	Lock Nut <sup>3</sup> / <sub>8</sub> - 16	2
24	15-521	Top Filter Bracket	1
25	18-259	Cross 1 <sup>1</sup> / <sub>4</sub>	1
26	50-394	Muffler Clamp	1
27	14-371	Strainer	1
28	15-522	Bottom Filter Bracket	1
29	HB-38-16-250	Bolt <sup>3</sup> / <sub>8</sub> - 16 x 2 <sup>1</sup> / <sub>2</sub>	2
	HNTL-38-16	Lock Nut <sup>3</sup> / <sub>8</sub> - 16	2
30	18-160	Close Nipple 1 <sup>1</sup> / <sub>4</sub>	1
31	15-385	Elbow 1 <sup>1</sup> / <sub>4</sub>	1
32	15-345	Belt Guard	1
33	16-998	Hypro® Pump	1
34	HB-12-13-450	Bolt 1 <sup>1</sup> / <sub>2</sub> - 13 x 4 <sup>1</sup> / <sub>2</sub>	1
	HNCL-12-13	Center Lock Nut 1 <sup>1</sup> / <sub>2</sub> - 13	1
	HMB-12-14	Machine Bushing 1 <sup>1</sup> / <sub>2</sub> x 14GA	6
35	15-414	Pulley BK30 x 1 <sup>1</sup> / <sub>2</sub>	1
	HSSHS-516-18-050	Socket Head Set Screw <sup>5</sup> / <sub>16</sub> - 18 x 1 <sup>1</sup> / <sub>2</sub>	1
36	HB-38-16-125	Bolt <sup>3</sup> / <sub>8</sub> - 16 x 1 <sup>1</sup> / <sub>4</sub>	2
	HNTL-38-16	Lock Nut <sup>3</sup> / <sub>8</sub> - 16	2
37	15-320	Belt 5L230	1
38	16-869	Belt L447	1



# SPRAY PUMP DRAWING

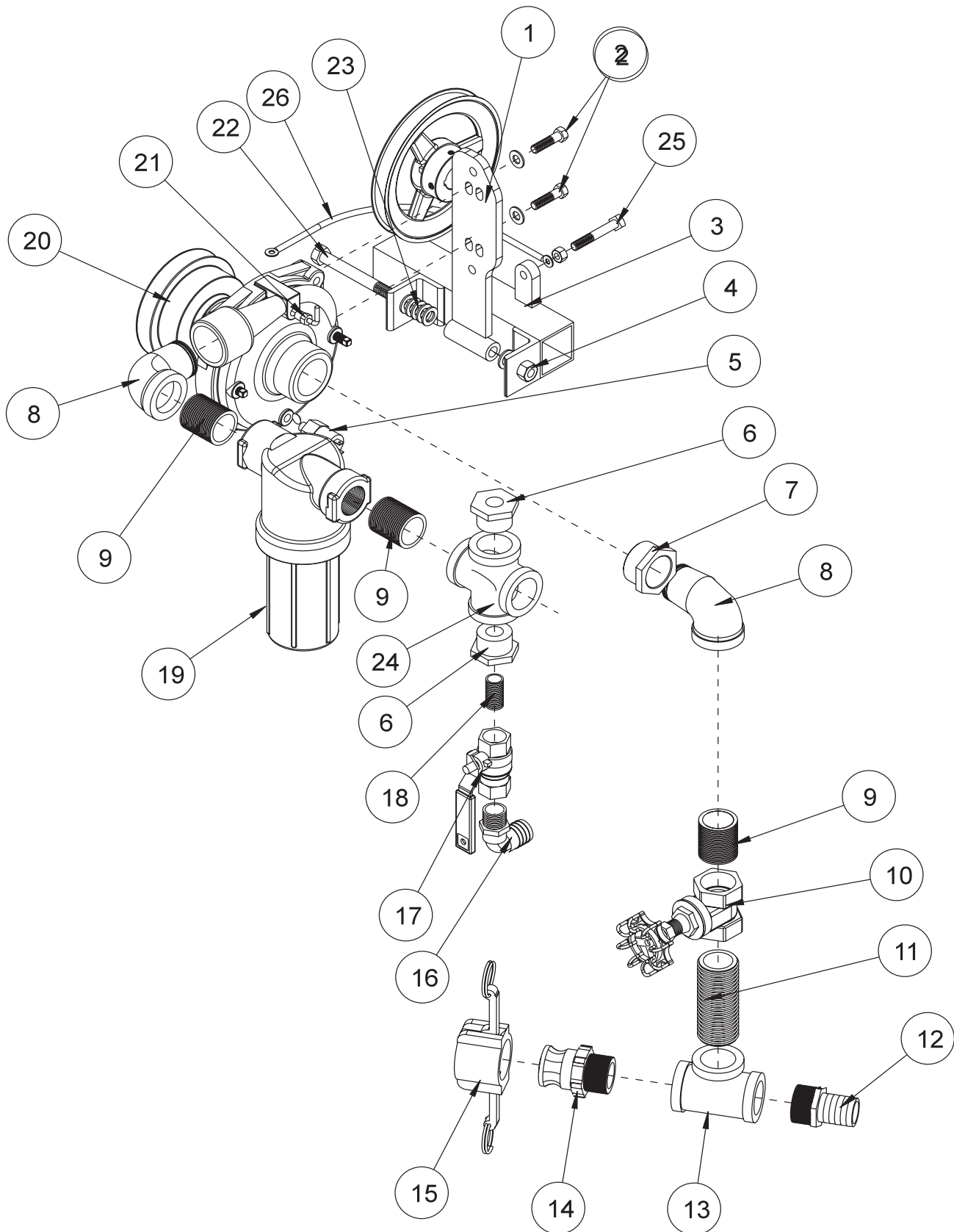

Parts



## SPRAY PUMP PARTS LIST

REF#	PART#	DESCRIPTION	QUANTITY
1	15-580	Pump Arm	1
2	HB-38-16-150	Bolt $\frac{3}{8}$ - 16 x $1\frac{1}{2}$	2
	HW-38	Washer $\frac{3}{8}$	2
	HNTL-38-16	Lock Nut $\frac{3}{8}$ - 16	2
3	14-353	Main Frame	1
4	HNCL-12-13	Center Lock Nut $\frac{1}{2}$ - 13	1
5	33-480	Pressure Switch	1
6	18-260	Bushing $1\frac{1}{4}$ x $\frac{3}{4}$	2
7	16-825	Reducer Bushing $1\frac{1}{2}$ x $1\frac{1}{4}$	1
8	15-385	Elbow $1\frac{1}{4}$	2
9	18-160	Close Nipple $1\frac{1}{4}$	3
10	16-170	Gate Valve $1\frac{1}{4}$	1
11	18-236	Nipple $1\frac{1}{4}$ x 4	1
12	16-161	Fitting $1\frac{1}{4}$ MPT x $1\frac{1}{4}$ HB	1
13	18-219	Tee $1\frac{1}{4}$	1
14	16-180	Quick Coupler $1\frac{1}{4}$ Male	1
15	16-935	Quick Coupler Cap	1
16	16-155	Elbow $\frac{3}{4}$ MPT x 1HB	1
17	16-859	Ball Valve $\frac{3}{4}$	1
18	18-073	Close Nipple $\frac{3}{4}$	1
19	14-371	Strainer	1
20	16-998	Hypro® Pump	1
	8859	Male Slide on Terminal	1
	8962	Heat Shrink $\frac{3}{16}$ X $1\frac{1}{4}$	1
21	33-494	Elbow $\frac{1}{8}$ MPT x $\frac{3}{16}$ HB	1
22	HB-12-13-450	Bolt $\frac{1}{2}$ - 13 x $4\frac{1}{2}$	1
23	HMB-12-14	Machine Bushing $\frac{1}{2}$ x 14GA	6
24	18-259	Cross $1\frac{1}{4}$	1
25	HSSQ-38-16-250	Square Head Set Screw $\frac{3}{8}$ - 16 x $2\frac{1}{2}$	1
	HN-38-16	Nut $\frac{3}{8}$ - 16	1
26	15-457	Ground Wire	1

# FRONT AXLE DRAWING

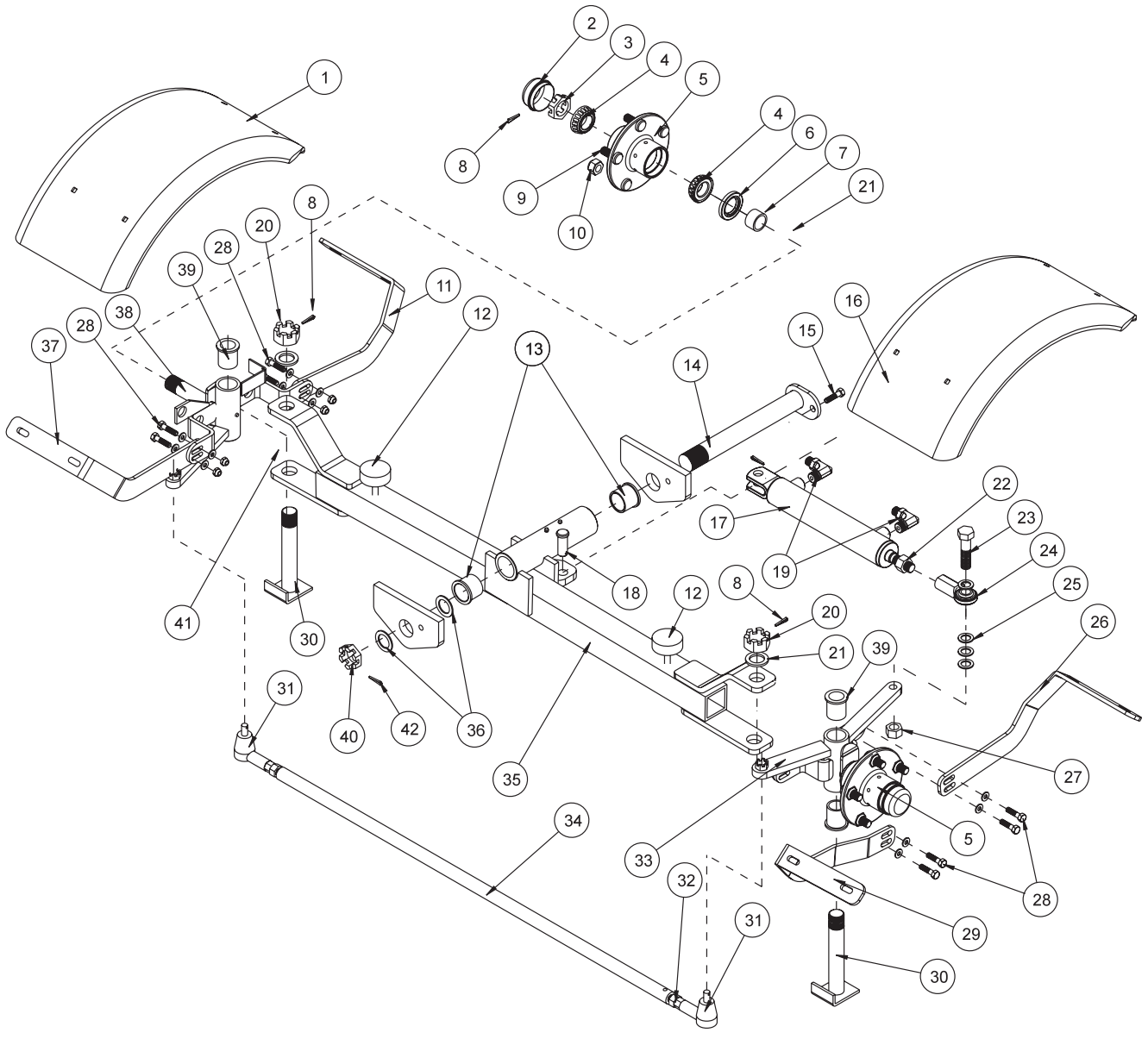

Parts

## FRONT AXLE PARTSLIST

REF#	PART#	DESCRIPTION	QUANTITY
1	10-180	Left Front Fender	1
	HBC-516-18-100	Carriage Bolt <sup>5</sup> / <sub>16</sub> - 18 x 1	4
	HW-516	Washer <sup>5</sup> / <sub>16</sub>	4
	HWL-516	Lock Washer <sup>5</sup> / <sub>16</sub>	4
	HN-516-18	Nut <sup>5</sup> / <sub>16</sub> - 18	4
2	80-167	Dust Cap	2
3	HNAR-100-14	Slotted Jam Nut 1 - 14	2
4	11-043	Bearing	4
5	80-019	Hub (includes Ref 2, 4, 6, 9, 10)	2
6	11-041	Oil Seal	2
7	11-042	Spacer	2
8	HP-18-150	Cotter Pin <sup>1</sup> / <sub>8</sub> x 1 <sup>1</sup> / <sub>2</sub>	4
9	27-022-02	Stud <sup>1</sup> / <sub>2</sub> - 20	10
10	HNL-12-20	Lug Nut <sup>1</sup> / <sub>2</sub> - 20	10
11	14-368	Left Front Fender Bracket - Front	1
12	50-081	Rubber Bumper	2
13	18-153	Bushing (part of 14-343)	2
14	14-344	Axle Pin	1
15	HB-516-18-125	Bolt <sup>5</sup> / <sub>16</sub> - 18 x 1 <sup>1</sup> / <sub>4</sub>	1
	HNTL-516-18	Lock Nut <sup>5</sup> / <sub>16</sub> - 18	1
16	10-159	Right Front Fender	1
	HBC-516-18-100	Carriage Bolt <sup>5</sup> / <sub>16</sub> - 18 x 1	4
	HW-516	Washer <sup>5</sup> / <sub>16</sub>	4
	HWL-516	Lockwasher <sup>5</sup> / <sub>16</sub>	4
	HN-516-18	Nut <sup>5</sup> / <sub>16</sub> - 18	4
17	50-456	Hydraulic Cylinder	1
	14-267	Seal Kit	1
18	HCP-58-150	Clevis Pin <sup>5</sup> / <sub>8</sub> x 1 <sup>1</sup> / <sub>2</sub>	1
	HP-18-100	Cotter Pin <sup>1</sup> / <sub>8</sub> x 1	1
19	18-171	<sup>11</sup> / <sub>16</sub> x <sup>9</sup> / <sub>16</sub> 90° Straight Thread Elbow	2
20	HNA-100-14	Slotted Axle Nut 1 - 14	2
21	HMB-100-10	Machine Bushing 1 x 10GA	4
22	HNJ-58-18	Jam Nut <sup>5</sup> / <sub>8</sub> - 18	1
23	HB-58-11-250	Bolt <sup>5</sup> / <sub>8</sub> - 11 x 2 <sup>1</sup> / <sub>2</sub>	1
24	18-154	Rod End	1
25	HMB-58-14	Machine Bushing <sup>5</sup> / <sub>8</sub> - 14	6
26	14-367	Right Front Fender Bracket - Front	1
27	HNTL-58-11	Lock Nut <sup>5</sup> / <sub>8</sub> - 11	1
28	HB-516-18-125	Bolt <sup>5</sup> / <sub>16</sub> - 18 x 1 <sup>1</sup> / <sub>4</sub>	8
	HW-14	Washer <sup>1</sup> / <sub>4</sub>	16
	HNTL-516-18	Lock Nut <sup>5</sup> / <sub>16</sub> - 18	8
29	14-356	Right Front Fender Bracket - Rear	1
30	16-076	King Pin	2
31	16-565	Rod End	2
32	HNM-12-125	Metric Nut M12 x 1.25	2
33	10-295	Right Spindle	1
	HG-14-28-180	Grease Fitting <sup>1</sup> / <sub>4</sub> - 28 x 180°	1
34	14-345	Tie Rod	1
35	14-457	Front Axle	1
	HG-14-28-180	Grease Fitting <sup>1</sup> / <sub>4</sub> - 28 x 180°	1
36	HMB-114-10	Machine Bushing 1 <sup>1</sup> / <sub>4</sub> x 10GA	2
37	14-357	Left Front Fender Bracket - Rear	1
38	10-294	Left Spindle	1
	HG-14-28-180	Grease Fitting <sup>1</sup> / <sub>4</sub> - 28 x 180°	1
39	33-086	Bushing (part of 10-294 & 10-295)	4
40	HNA-114-12	Axle Nut 1 <sup>1</sup> / <sub>4</sub> - 12	1
41	HMB-100-14	Machine Bushing 1 x 14GA	4
42	HP-18-200	Cotter Pin <sup>1</sup> / <sub>8</sub> x 2	1

# CLUTCH LINKAGE DRAWING

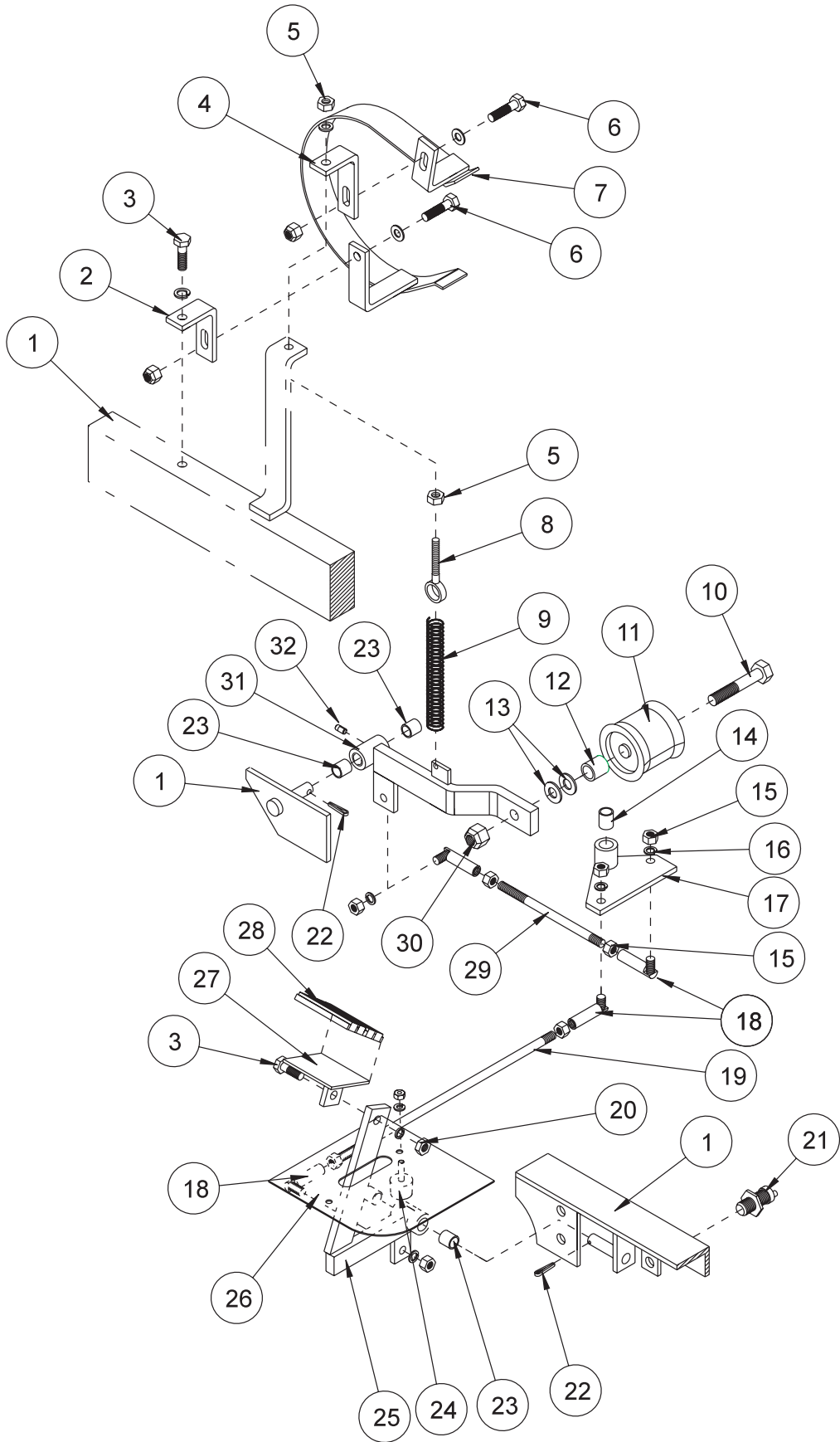

Parts

## CLUTCH LINKAGE PARTS LIST

REF#	PART#	DESCRIPTION	QUANTITY
1		Part of Main Frame	
2	15-482	Bottom Mount Bracket	1
3	HB-38-16-100	Bolt $\frac{3}{8}$ - 16 x 1	2
	HWL-38	Lockwasher $\frac{3}{8}$	2
4	15-483	Top Mount Bracket	1
5	HN-516-18	Nut $\frac{5}{16}$ - 18	2
	HW-516	Washer $\frac{5}{16}$	1
6	HB-38-16-125	Bolt $\frac{3}{8}$ - 16 x $1\frac{1}{4}$	2
	HW-38	Washer $\frac{3}{8}$	2
	HNTL-38-16	Lock Nut $\frac{3}{8}$ - 16	2
7	15-481	Belt Guard	1
8	20-008	Eye Bolt $\frac{5}{16}$ - 18	1
9	16-830	Spring	1
10	HB-12-13-300	Bolt $\frac{1}{2}$ - 13 x 3	1
11	16-013	Idler Pulley	1
12	15-376	Clutch Arm Spacer	1
13	HMB-12-14	Machine Bushing $\frac{1}{2}$ x 14GA	As Required
14	10-007	Oilite Bushing (part of 15-337)	1
15	HN-38-24	Nut $\frac{3}{8}$ - 24	8
16	HWL-38	Lockwasher $\frac{3}{8}$	4
17	15-337	Clutch Relay	1
	HB-12-13-275	Bolt $\frac{1}{2}$ - 13 x $2\frac{3}{4}$	1
	HNTL-12-13	Lock Nut $\frac{1}{2}$ - 13	1
18	21-173	Ball Joint $\frac{3}{8}$ - 24	4
19	15-348	Long Clutch Rod	1
20	HN-38-16	Nut $\frac{3}{8}$ - 16	1
21	22-002	Interlock Switch	1
22	HP-18-100	Cotter Pin $\frac{1}{8}$ x 1	2
23	20-019	Bushing (part of 15-360 & 15-341)	4
24	15-013	Rubber Bumper	1
	HWL-14	Lockwasher $\frac{1}{4}$	1
	HN-14-20	Nut $\frac{1}{4}$ - 20	1
25	15-360	Clutch Pedal	1
26	14-328	Floor Board	1
27	16-062	Pedal	1
28	15-015	Pedal Pad	1
29	15-349	Short Clutch Rod	1
30	HNTL-12-13	Lock Nut $\frac{1}{2}$ - 13	1
31	15-341	Clutch Arm	1
32	HG-14-28-180	Grease Fitting $\frac{1}{4}$ - 28 x 180°	1

# ENGINE AND CONTROL PANEL DRAWING

Parts

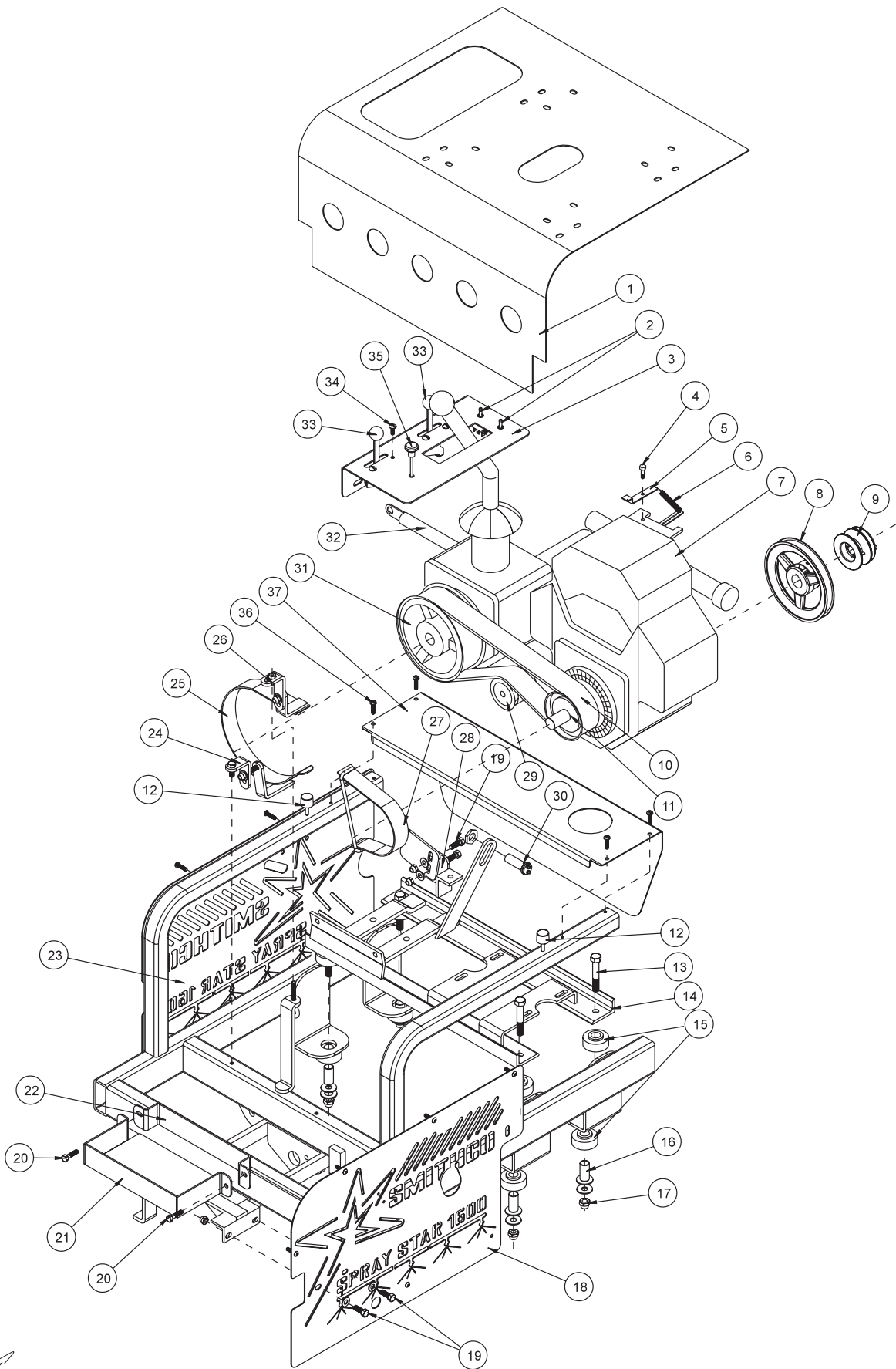

## ENGINE AND CONTROL PANEL PARTS LIST

REF#	PART#	DESCRIPTION	QUANTITY
1	15-356	Engine/Seat Cover	1
	8803-41	Trim	1
2	16-755	Boom Control Switch	2
	15-472	Switch Boot	2
3	15-329	Control Panel	1
	14-366	Decal, Control Panel	1
4	HB-14-20-075	Bolt $\frac{1}{4}$ - 20 x $\frac{3}{4}$	1
	HW-14	Washer $\frac{1}{4}$	1
	HNTL-14-20	Lock Nut $\frac{1}{4}$ - 20	1
5	15-335	Governor Linkage Arm	1
6	16-046	Extension Spring	1
7	15-373	Kohler 20 hp Command Engine	1
	8800-9	Fuel Hose	1
	18-186	Hose Clamp	2
	50-403	Fuel Filter	1
	HB-38-16-175	Bolt $\frac{3}{8}$ - 16 x $1\frac{3}{4}$	4
	HW-38	Washer $\frac{3}{8}$	4
	HNTL-38-16	Lock Nut $\frac{3}{8}$ - 16	4
	15-316	Pulley BK72 x $1\frac{1}{8}$	1
	HKSQ-14-150	Machine Key $\frac{1}{4}$ x $\frac{1}{4}$ x $1\frac{1}{2}$	1
	15-318	Pulley BK30H with Hub $1\frac{1}{8}$	1
9	HKSQ-14-150	Machine Key $\frac{1}{4}$ x $\frac{1}{4}$ x $1\frac{1}{2}$	1
	16-827	Belt	1
11	16-820	Pulley $4\frac{1}{4}$ OD with Hub	1
	HKSQ-14-150	Machine Key $\frac{1}{4}$ x $\frac{1}{4}$ x $1\frac{1}{2}$	1
12	15-013	Rubber Bumper	2
13	HB-12-13-300	Bolt $\frac{1}{2}$ - 13 x 3	4
14	15-357	Engine Frame	1
15	60-107	Rubber Bushing	8
16	60-168	Spacer	4
	HNFL-12-13	Flange Whiz Lock Nut $\frac{1}{2}$ - 13	4
	HW-58	Washer $\frac{5}{8}$	4
18	HW-716	Washer $\frac{7}{16}$	4
	14-349	Left Side Panel	1
	HSDPS-14-100	Pan Head Drill Screw SS $\frac{1}{4}$ x 1	5
19	HB-38-16-100	Bolt $\frac{3}{8}$ - 16 x 1	4
	HW-38	Washer $\frac{3}{8}$	8
	HNTL-38-16	Lock Nut $\frac{3}{8}$ - 16	4
20	HB-516-18-125	Bolt $\frac{5}{16}$ - 18 x $1\frac{1}{4}$	2
	HWL-516	Lockwasher $\frac{5}{16}$	2
	HN-516-18	Nut $\frac{5}{16}$ - 18	2
21	15-330	Battery Box	1
	33-216	Battery	1
	22-054	Black Battery Cable	1
22	15-388	Battery Box Front	1
23	14-350	Right Side Panel	1
	HSDPS-14-100	Pan Head Drill Screw SS $\frac{1}{4}$ x 1	6
24	15-482	Bottom Mount Bracket	1

(Continued on next page)

# ENGINE AND CONTROL PANEL DRAWING

Parts

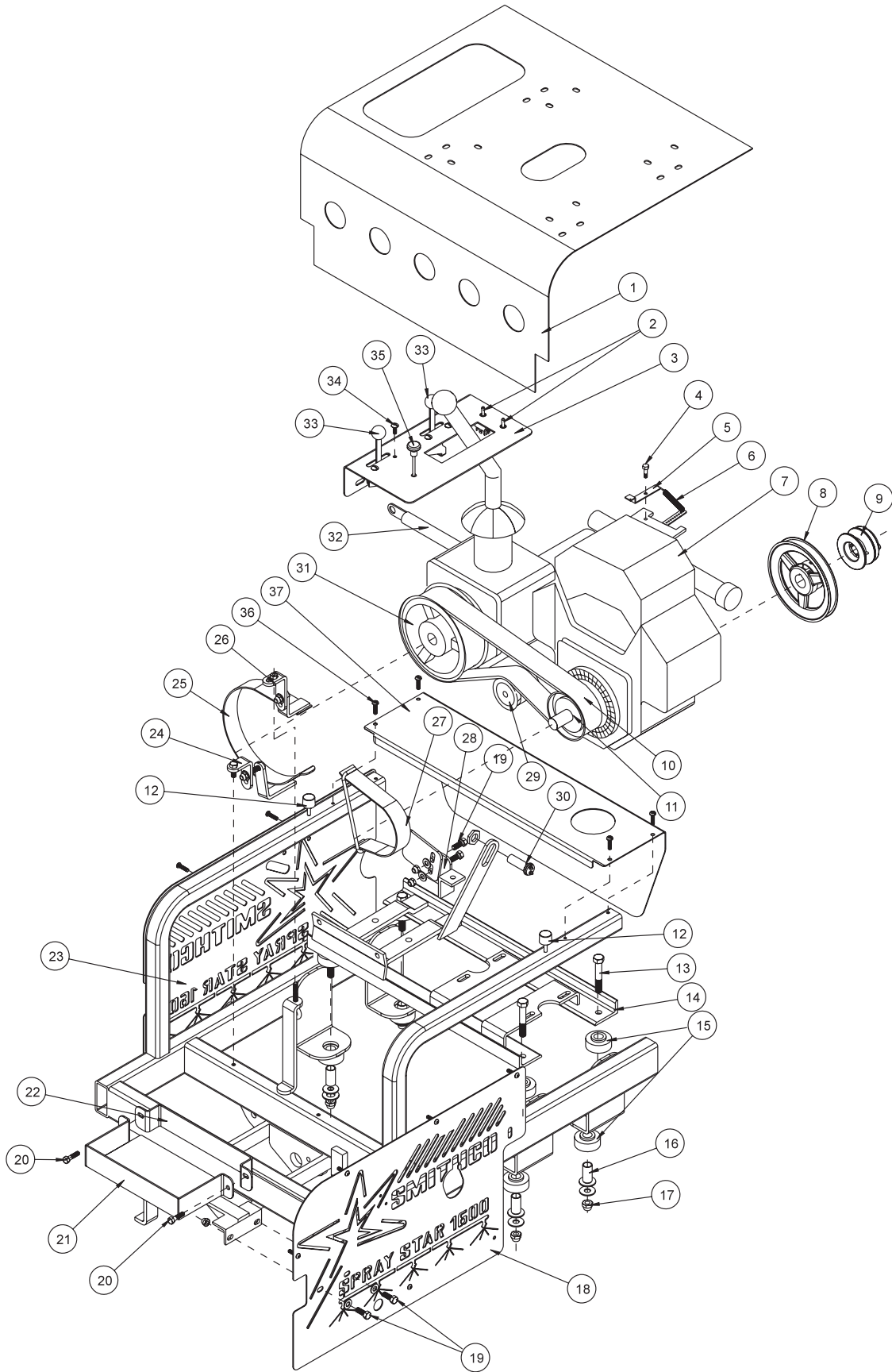



## ENGINE AND CONTROL PANEL PARTS LIST

REF#	PART#	DESCRIPTION	QUANTITY
25	15-481	Belt Guard	1
26	15-483	Top Mounting Bracket	1
27	15-555	Left Belt Guard	1
28	15-556	Guard Mount	1
29	16-013	Idler Pulley	1
30	16-883	Magnetic Sensor	1
31	16-821	Pulley 7 <sup>1</sup> / <sub>2</sub> OD with Hub	1
	HWK-14-1125	Woodruff Key 1/4 x 1 <sup>1</sup> / <sub>8</sub>	1
32	50-323	Red Battery Cable	1
33	13-568	Throttle Cable	2
34	HSTP-14-20-075	Phillips Truss Head Machine Screw 1/4 - 20 x 3/4	4
	HW-14	Washer 1/4	4
	HWL-14	Lockwasher 1/4	4
	HN-14-20	Nut 1/4 - 20	4
35	11-086	Choke Cable	1
36	HSDPS-14-100	Pan Head Drill Screw SS 1/4 x 1	4
37	14-326	Rear Engine Cover	1
NS	17-154	Cable Clamp	1
NS	21-161	Wire Block	4

# GAS TANK DRAWING

Parts

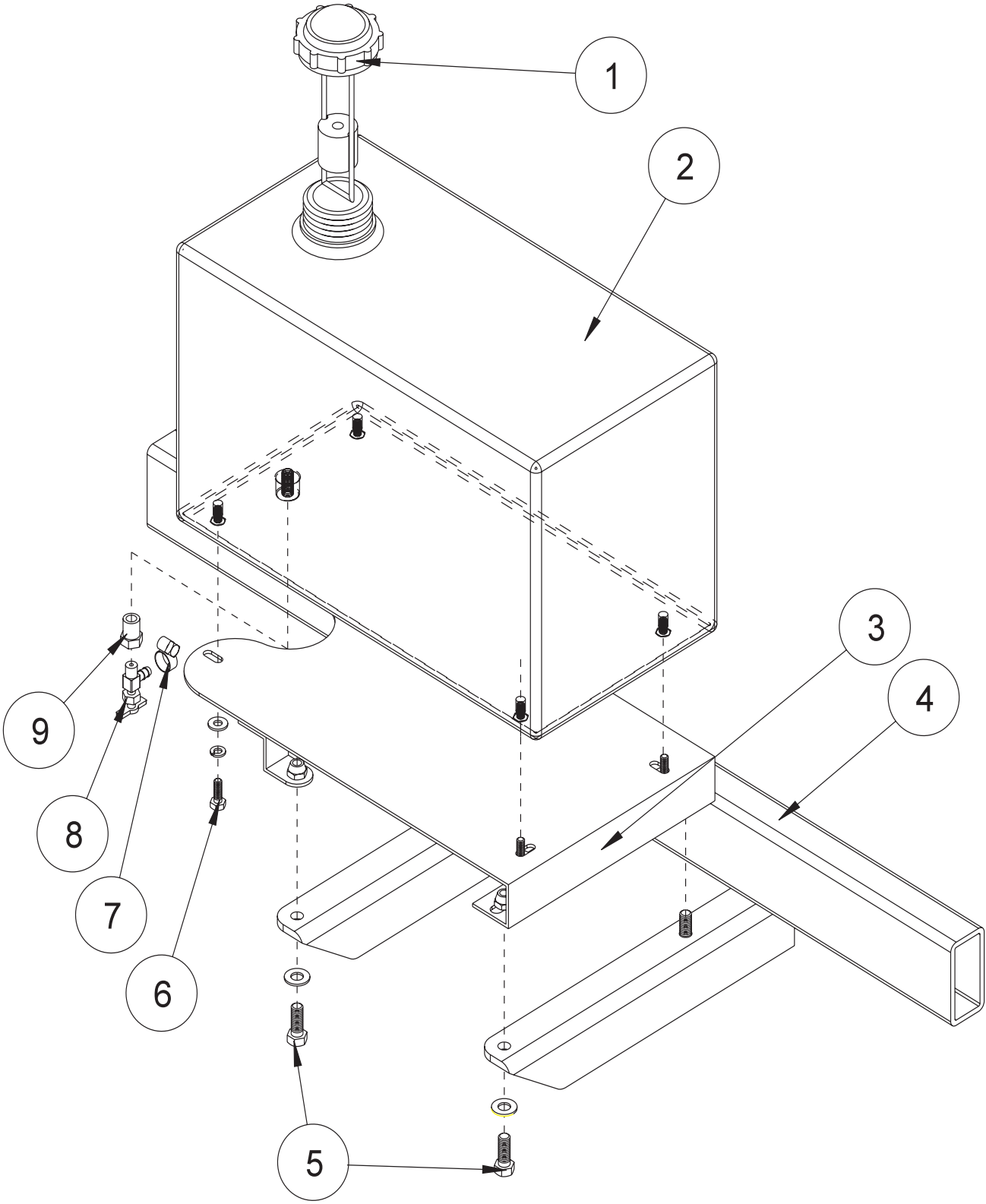

## GAS TANK PARTS LIST

REF#	PART#	DESCRIPTION	QUANTITY
1	15-492	Cap with Gauge	1
2	15-491	5 Gallon gas Tank	1
3	14-337	Gas Tank Bracket	1
4		Main Frame	
5	HB-38-16-100	Bolt $\frac{3}{8}$ - 16 x 1	4
	HW-38	Washer $\frac{3}{8}$	4
	HNTL-38-16	Lock Nut $\frac{3}{8}$ - 16	4
6	HB-14-20-075	Bolt $\frac{1}{4}$ - 20 x $\frac{3}{4}$	4
	HW-14	Washer $\frac{1}{4}$	4
	HWL-14	Lockwasher $\frac{1}{4}$	4
7	18-186	Hose Clamp	2
	8800-25	Fuel Hose $\frac{1}{4}$ " x 25"	1
8	15-039	Fuel Valve	1
9	18-042	Reducer Bushing $\frac{1}{4}$ x $\frac{1}{8}$	1

# TURBO QUAD AGITATOR DRAWING

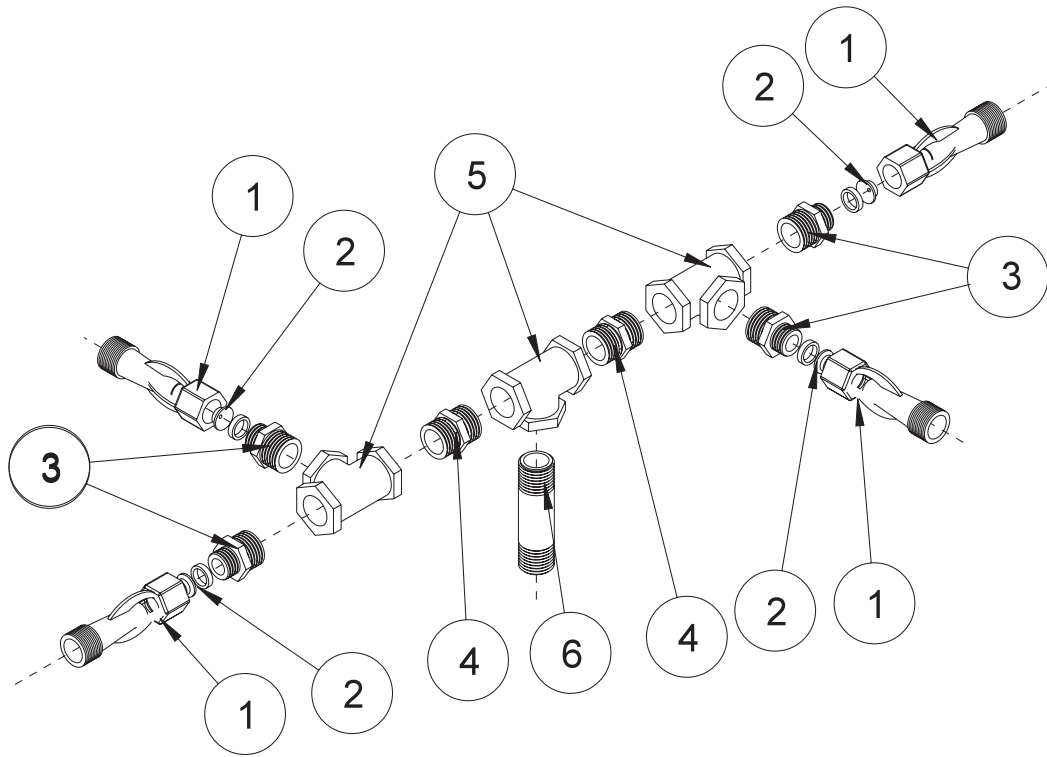

# 14-371 STRAINER DRAWING

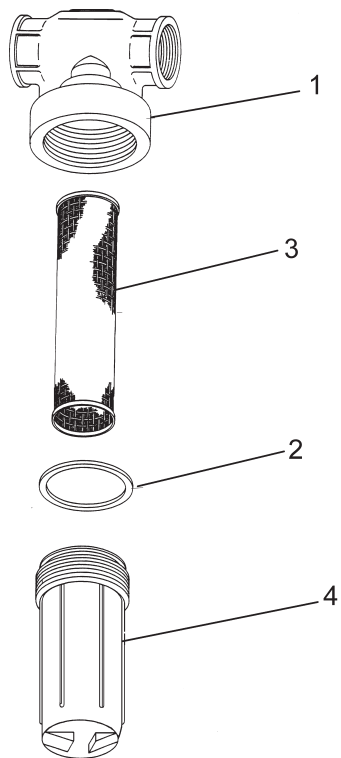

## TURBO QUAD AGITATOR PARTS LIST

REF#	PART#	DESCRIPTION	QUANTITY
1	16-036	Agitator Jets (includes one each $\frac{1}{8}$ ", $\frac{5}{32}$ ", and $\frac{3}{16}$ " orifices)	4
2		Interchangeable Nozzles $\frac{3}{16}$ " (factory installed)	4
3	16-173	Reducer $\frac{3}{4} \times \frac{1}{2}$	4
4	16-158	Close Nipple $\frac{3}{4}$	2
5	16-157	Tee Female Pipe Thread $\frac{3}{4} \times \frac{3}{4} \times \frac{3}{4}$	3
6	16-172	Nylon Nipple $\frac{3}{4}$ NPT x $3\frac{1}{2}$	1
	*	One each comes with 16-036 Agitator Jet.	

## 14-371 STRAINER PARTS LIST

REF#	PART#	DESCRIPTION	QUANTITY
1	14-371-01	Head $1\frac{1}{4}$ (Poly)	1
2	16-968-02	Gasket	1
3	16-968-03	Screen	1
4	14-371-02	Bowl	1

# 15-301 ORBITOR DRAWING

Parts

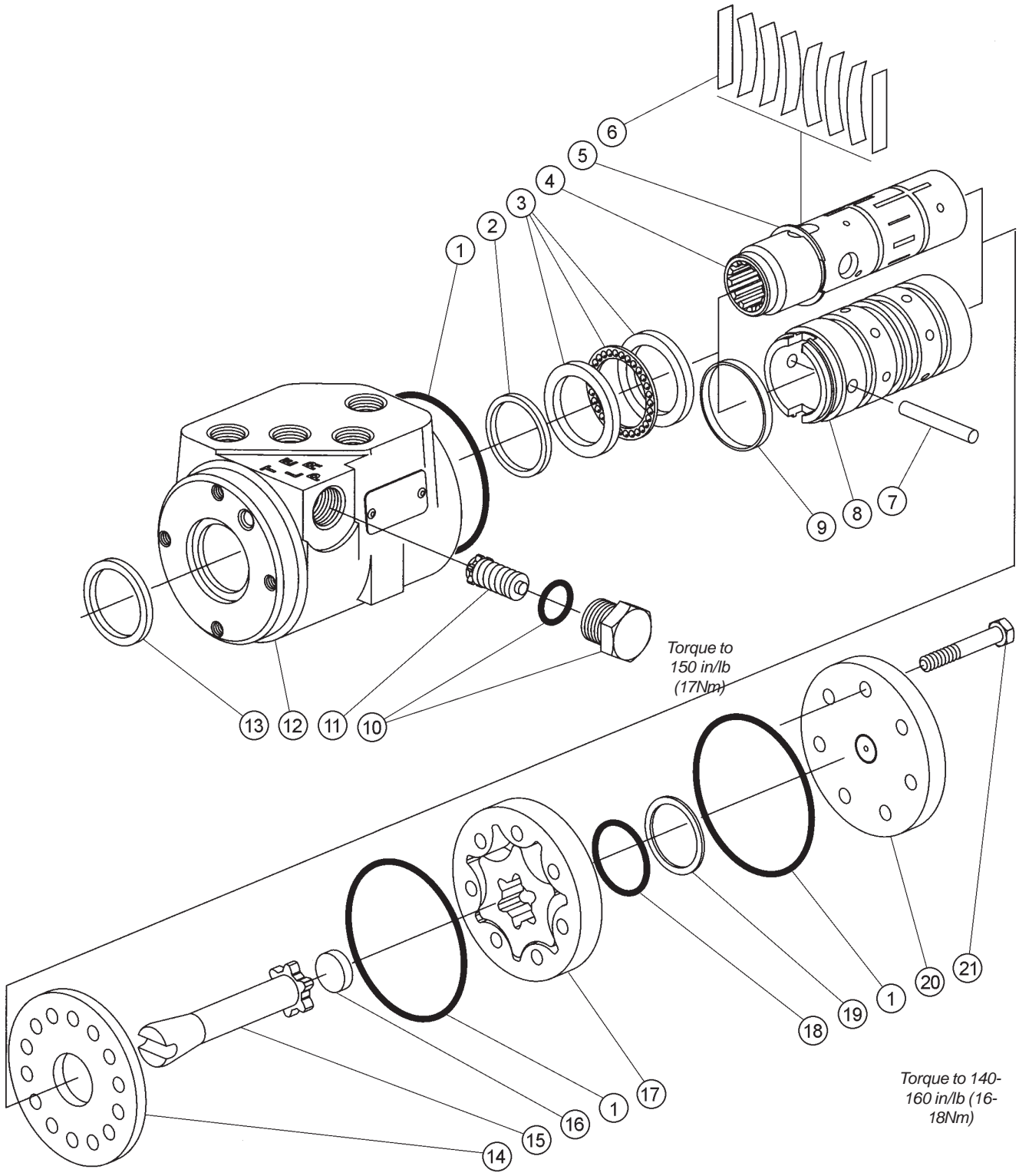

# 15-301 ORBITOR PARTS LIST

REF#	PART#	DESCRIPTION	QUANTITY
1*		O-Ring Seal	3
2*		Quad Seal	1
3	15-301-14	Bearing Kit	1
		Bearing Race	2
		Bearing	1
4		Spool	1
5	15-301-13	External Retaining Ring	1
6	15-301-15	Spring Centering Kit (Includes Ref# 9)	1
		Spring Spacer	2
		Centering Spring	6
		Spring Retaining Ring	1
7	15-301-08	Pin	1
8		Sleeve	1
9		Retainer	1
10	15-301-11	Plug and O-ring	1
*		O-Ring Seal	1
		Plug	1
11	15-301-12	Relief Valve/Check (1015 psi (70 bar))	1
12		Housing	1
13*		Dust Seal	1
14	15-301-06	Wear Plate	1
15	15-301-07	Drive	1
16	15-301-05	Spacer	1
17	15-301-04	Gerotor	1
18*		O-Ring	1
19*		Seal	1
20	15-301-03	End Cap	1
21	15-301-02	Cap Screw	7
*	15-301-01	Seal Kit	

## 15-301 ORBITOR SPECIFICATIONS

Maximum System Pressure	1015 psi (70 bar)
Maximum Back Pressure	150 psi (10 bar)
Maximum System Operating Temperature.	200°F (93°C)
Maximum Flow	4 gpm (15 lpm)
Maximum Temperature Differential between Steering Unit and System.	50°F (28°C)
Input Torque Powered	15-25 lb/in @ 100 psi tank pressure (2-3 Nm @ 7 bar)
Input Torque Maximum Non-powered	60 lb/ft (81 Nm)
Rotation Limits	None
Fluid	SAE 10W-40 API Service SJ or higher Motor Oil
Check Valve for Manual Steering	Yes
Relief Valve Setting	1015 psi (70 bar)
Ports	$\frac{9}{16}$ - 18 SAE O-Ring 4 Ports
Displacement	61 cu. in/ R (100 cu cm/R)

# 15-409 3-SPEED TRANSMISSION DRAWING

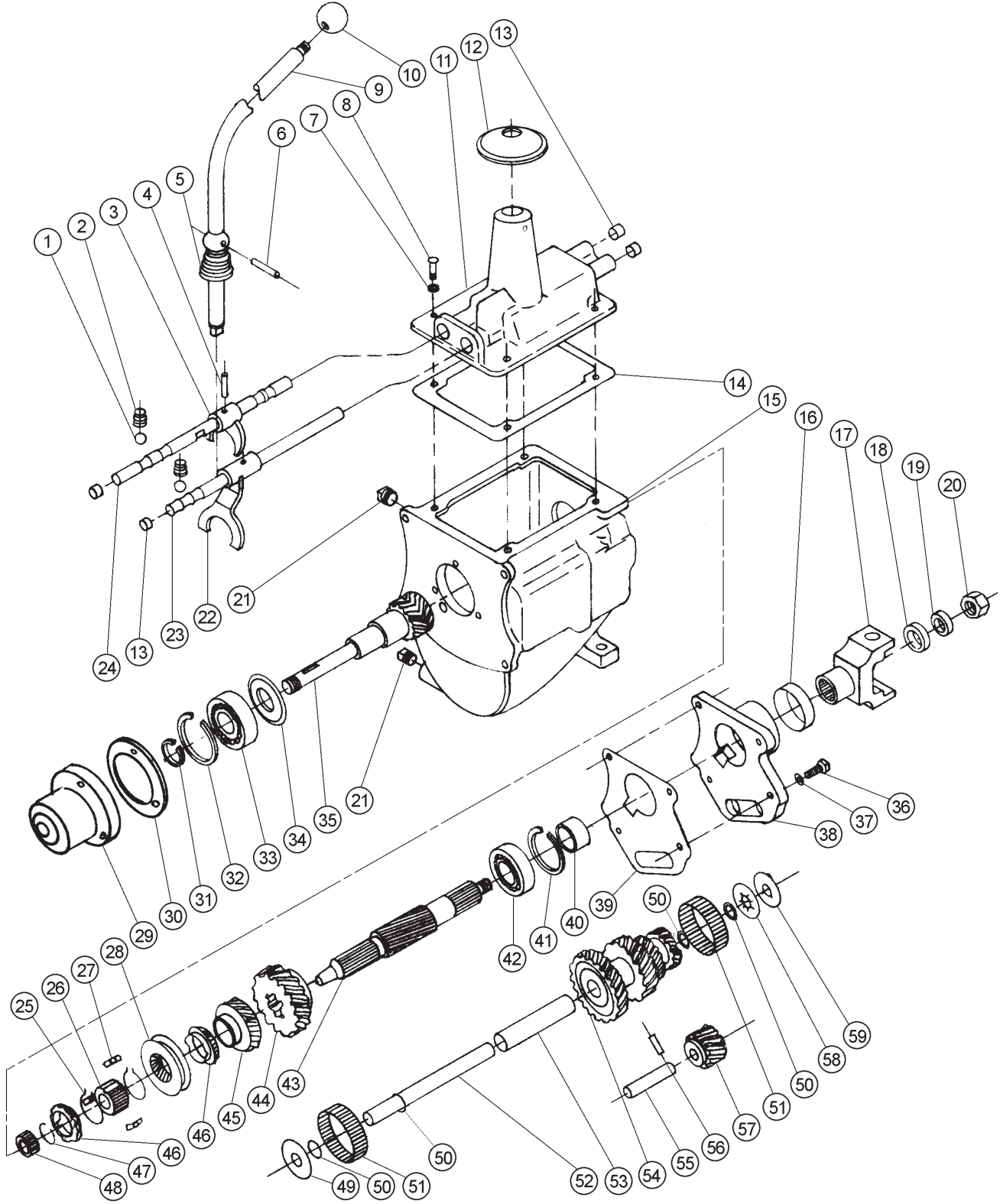

Parts



## 15-409 3-SPEED TRANSMISSION PARTS LIST

REF#	PART#	DESCRIPTION	QUANTITY
1†	16-341	Ball $\frac{3}{8}$ detent	2
2†	16-342	Poppet Spring	2
3†	16-348	Low & Reverse Shift Fork	1
4†	16-343	Rail Pin	2
5†	16-344	Shift Spring	1
6†	16-308	Pin	1
7†	HWL-516	Lockwasher $\frac{5}{16}$	7
8†	HB-516-18-075	Bolt $\frac{5}{16}$ - 18 x $\frac{3}{4}$	7
9†	15-458	Shift Lever	1
10†	16-259	Shift Knob (not included with 15-409)	1
	16-011	Decal Shift (not included with 15-409)	1
11†	16-301	Transmission Housing Cover	1
12†	16-039	Rubber Rain/Dust Boot (not included with 15-409)	1
13†	16-340	Plug Cap	4
14†	16-302	Housing Cover Gasket	1
15	16-330	Top Shift type Case	1
16	16-313	Seal M/S (rear)	1
17	16-004	Yoke	1
18	16-306	Washer M/S	1
19	HWL-34	Lockwasher $\frac{3}{4}$	1
20	16-307	Nut	1
21	16-336	Drain/Fill Plug	2
22†	16-337	High & Inter. Shift Fork	1
23†	16-338	High & Inter. Shift Rail	1
24†	16-339	Low & Reverse Shift Rail	1
25*	16-351	Syncro Snap Ring	2
26*	16-352	Syncro Hub	1
27*	16-350	Shift Plate	3
28*	16-908	Sleeve	1
29	16-054	Tran. Bearing Housing (not included with 15-409)	1
	16-008	Bearing (part of 16-054)	1
	HB-38-16-125	Bolt $\frac{3}{8}$ - 16 x $1\frac{1}{4}$	3
	HW-38	Washer $\frac{3}{8}$	3
30	16-218	Gasket (not included with 15-409)	1
31	16-335	Snap Ring (small)	1
32	16-334	Snap Ring (large)	1
33	16-333	Bearing M/D Gear	1
34	16-332	Oil Baffle	1
35	16-331	Gear M/D keyed (input shaft)	1
36	16-347	Bolt $\frac{7}{16}$ - 14 x 1 (black)	4
37		Washer $\frac{7}{16}$ (star burst)	4
38	16-314	Rear Bearing Retainer	1
39	16-326	Gasket M/D retainer	1
* †	16-328 16-299	Synchronized Assembly with BR Rings Transmission Cover Assembly	1

(Continued on next page)

# 15-409 3-SPEED TRANSMISSION DRAWING

Parts

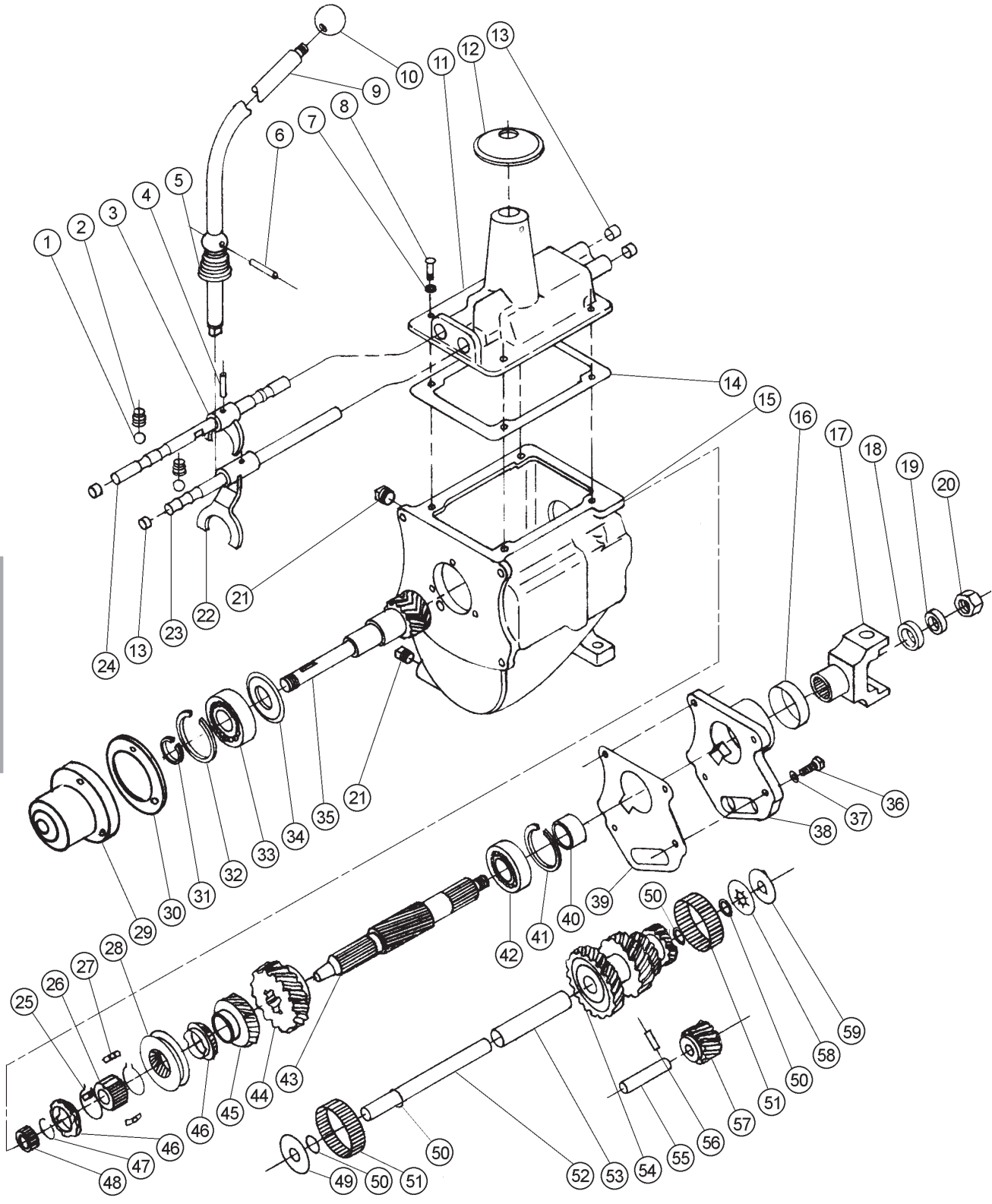

## 15-409 3-SPEED TRANSMISSION PARTS LIST

40	16-309	Spacer (speedometer)	1
41	16-305	Snap Ring	1
42	16-304	Rear Bearing	1
43	16-303	Main Shaft	1
44	16-310	Gear M/S (low & reverse)	1
45	16-311	Gear M/S (2nd)	1
46*	16-312	Syncro Ring M/S 2nd & 3rd	2
47	16-329	Snap Ring	1
48	16-327	Needle Bearing (13 rollers per set)	1 set
49	16-325	Steel Washer	1
50	16-317	Thrust Washer	4
51	16-318	Main Needle Bearing (20 rollers per set)	2 sets
52	16-324	Cluster Gear Shaft C/S	1
53	16-323	Cluster Spacer Tube	1
54	16-322	Gear C/S (cluster)	1
55	16-321	Reverse Gear Shaft	1
56	16-320	Lockplate	1
57	16-319	Reverse Idler Gear	1
58	16-316	Thrust Washer	1
59	16-315	Thrust Washer	1
*	16-328	Synchronized Assembly with BR Rings	1

# 16-998 HYPRO PUMP DRAWING

Parts

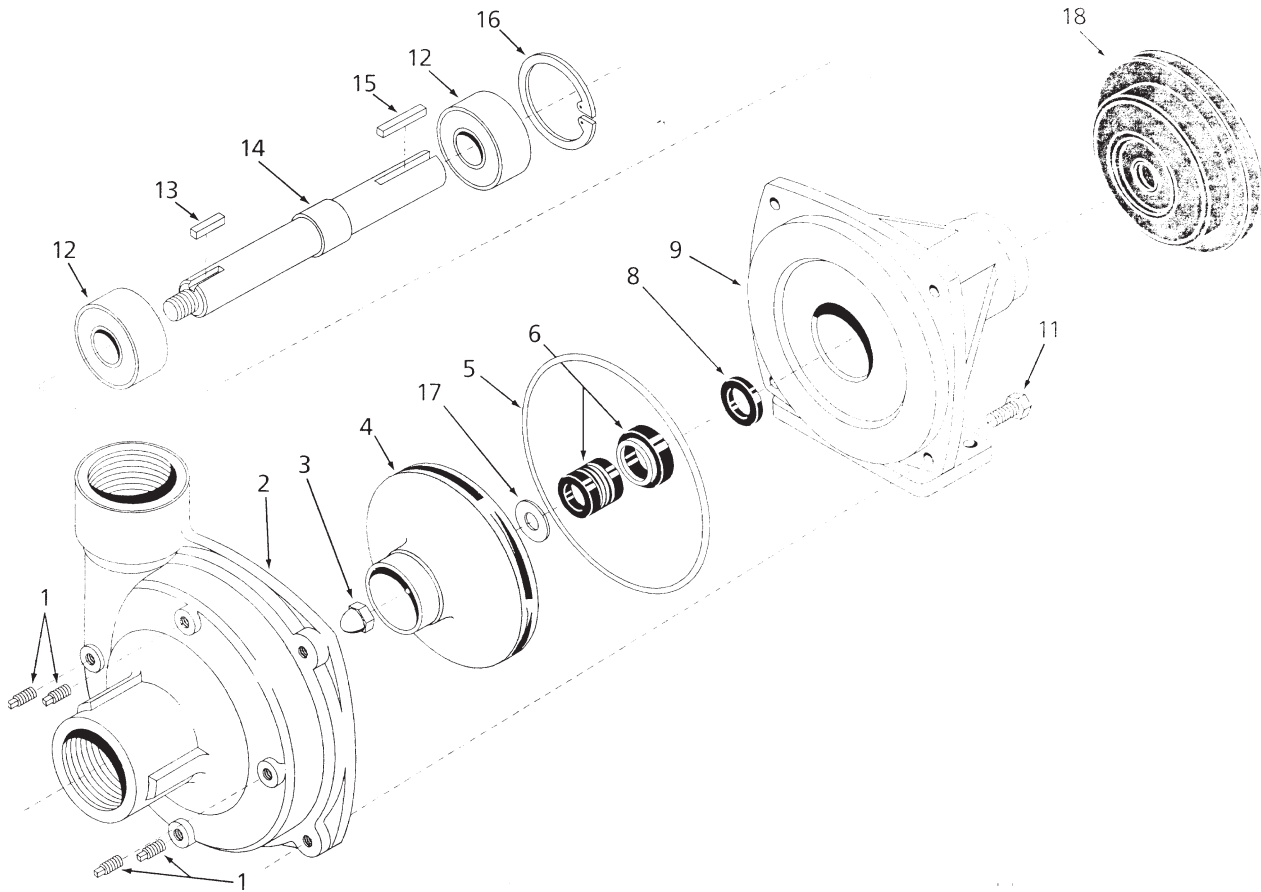

## 16-998 HYPRO® PUMP PARTS LIST

REF#	PART#	DESCRIPTION	QUANTITY
1	16-998-01	Drain Plug	4
2	16-998-02	Pump Casing	1
3	16-998-03	Impeller Nut	1
4	16-966-16	Impeller	1
5*	16-998-04	O-Ring	1
6*	16-998-05	Mechanical Seal (Silicon Carbide)	1
8*	16-966-06	Slinger Ring	1
9	16-998-06	Mounting Flange	1
11	16-998-07	Bolt	4
12	16-998-12	Ball Bearing	2
13	16-998-08	Key	1
14	16-998-09	Pump Shaft	1
15	16-822-20	Key	1
16	16-966-13	Bearing Retainer	1
17*	16-998-10	Gasket	1
18	16-994-01	Clutch	1
*	16-998-11	Silicone - Carbon Seal Kit	

When servicing the spray pump or filter, all control valves must be shut off if there is liquid in the tank.

### **NOTE:**

#### **TROUBLESHOOTING**

See maintenance section for daily maintenance instructions

Symptom	Probable Cause	Corrective Action
The pump dose not draw water.	One or more valves are seating improperly.	Remove valve and check for debris.
	Suction line is plugged or collapsed. Clogged strainer	Examine suction line. Clean strainer.
The liquid flow is irregular.	The chare in the pulsation dampener is incorrect	Check pressure in pulsation dampener (20% working pressure.)
Output drops and the pump is noisy.	One or more valves are seating improperly.	Remove valve and check for debris. Examine the valve seating and clean them.
Oil comes out of the discharge port or oil is a milky color	One or more diaphragms split.	Remove manifold and heads. Drain oil and clean crankcase of water. Replace diaphragms, head and manifold. Refill with oil.
	Oil level is too low.	Add oil to correct level (halfway up the sight tube.)

# 16-037 REAR AXLE DRAWING

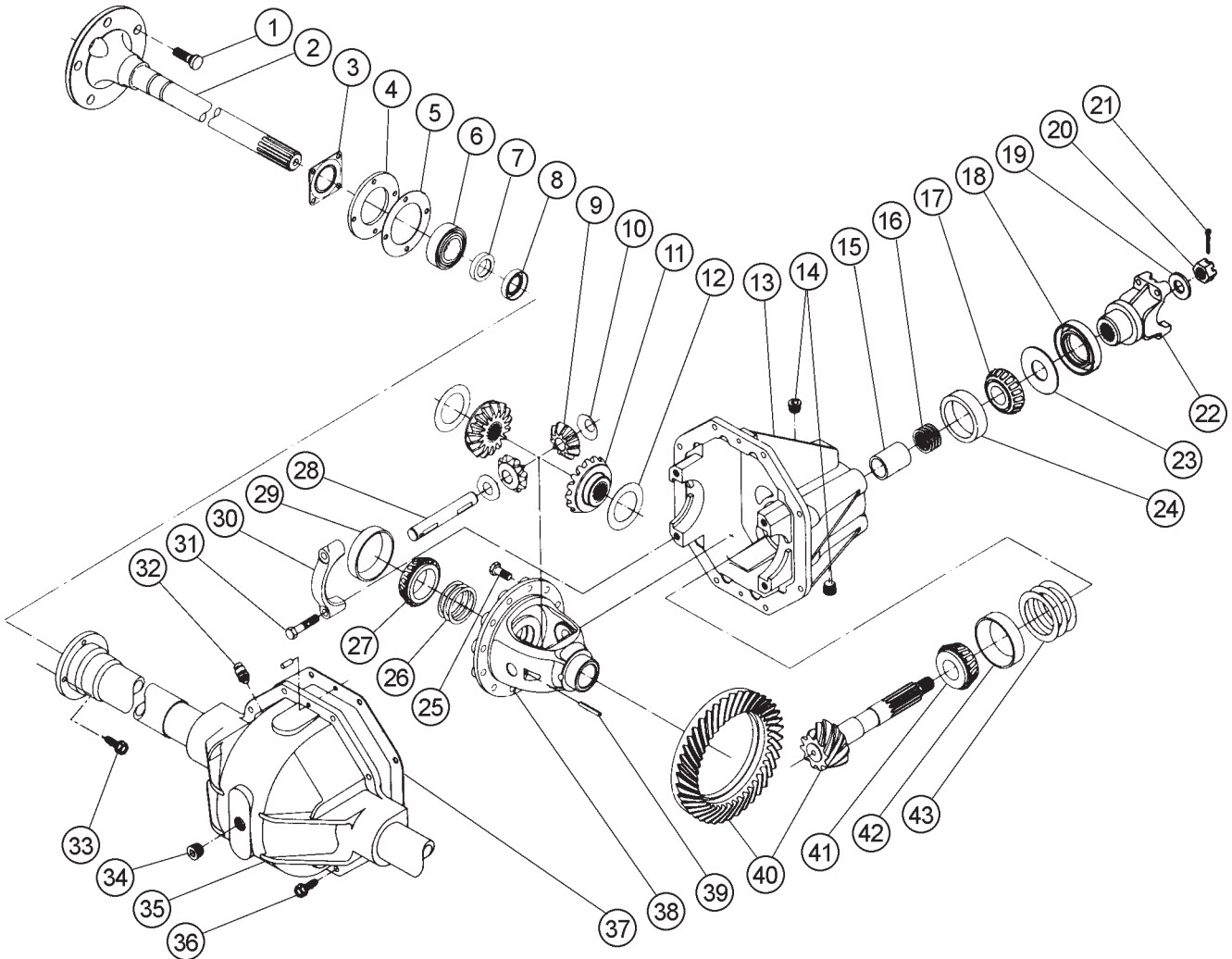

Parts

## 16-037 REAR AXLE PARTS LIST

REF#	PART#	DESCRIPTION	QUANTITY
1	16-510	Wheel Bolt	10
	16-562	Lock Nut	2
2	16-511	Axle Shaft (Left and Right)	2
3	16-513	Oil Seal	2
4		Part of Brake Dust Shield	
5	16-518	RTV Gasket Eliminator (Loctite Brand)	As Required
6	16-515	Bearing	2
7	16-516	Wheel Bearing Retainer Ring	2
8	16-519	Oil Seal	2
9	16-495	Pinion Mate	2
10	16-496	Thrust Washer	2
11	16-494	Side Gear	2
12	16-493	Thrust Washer	2
13	16-501	Carrier	1
14	16-502	Oil Plug	2
15	16-503	Sleeve Spacer	1
16	16-504	Shim (Set of 4)	2-4
17	16-506	Bearing Cone	1
18	16-508	Oil Seal	1
19	16-816	Flat Washer	1
20	HNA-58-18	Axle Nut $\frac{5}{8}$ - 18	1
21	HP-18-150	Cotter Pin $\frac{1}{8}$ x $1\frac{1}{2}$	1
22	16-509	End Yoke	1
23	16-507	Shim	1
24	16-505	Bearing Cup	1
25	16-489	Drive Gear Screw	14
26	16-488	Shim (Set of 4)	4-6
27	16-487	Bearing Cone	2
28	16-492	Pinion Mate Shaft	1
29	16-486	Bearing Cup	2
30		Bearing Cap	
31	16-484	Bearing Cup Screw	4
32	16-481	Vent Assembly	1
33	16-963	Bolt Kit (Includes Bolt, Washer, and Nut (Replace all 8 when replacing one))	8
34	18-069	Plug $\frac{1}{2}$ NPT	1
35	16-480	Rear Axle Housing	1
36	16-815	Housing Bolt	8
	16-561	Hex Nut	8
	16-563	Lockwasher	8
37	16-482	RTV Sealant	As Required
38	16-490	Differential Case	1
39	16-491	Pinion Lock Pin	1
40	16-497	Gear and Pinion Assembly 12.25:1 Ratio (Matched Set)	1
41	16-498	Bearing Cone	1
42	16-499	Bearing Cup	1
43	16-500	Spacer (Set of 3)	2-4

16-037 Includes Brakes and Drums

# BRAKE ASSEMBLY DRAWING

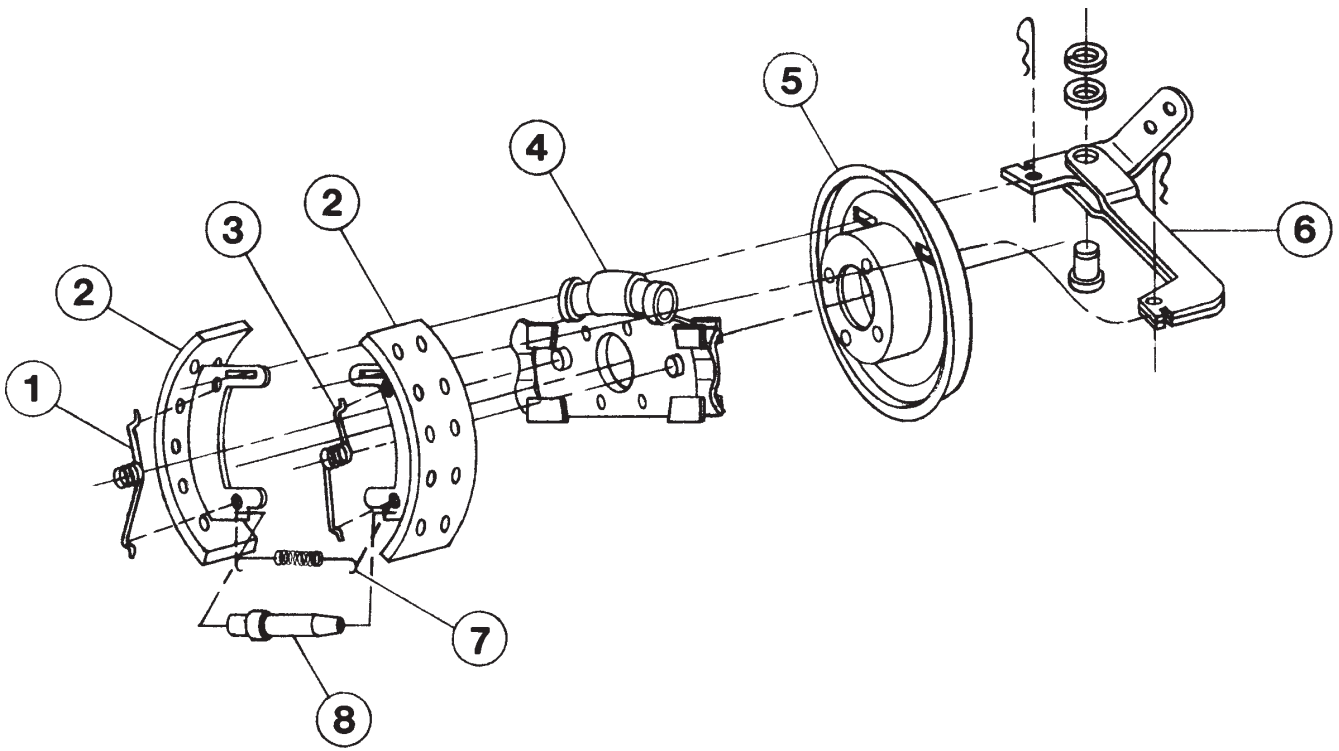

Parts



## BRAKE ASSEMBLY PARTS LIST

REF#	PART#	DESCRIPTION	QUANTITY
1	16-704	Shoe Return Spring (Green)	1
2	16-725	Shoe and Lining Kit	2 sets required
3	16-705	Shoe Return Spring (Red)	1
4	16-723	Spider Torque Kit	1
5	16-709	Dust Shield and Bearing Retainer	1
6	16-713	Brake Lever Kit (Right or Left)	1
7	16-719	Adjusting Spring	1
8	16-720	Adjusting Screw Kit	1
	16-514	Left Brake Assembly (part of 16-037)	1
	16-554	Right Brake Assembly (part of 16-037)	1
	16-559	Brake Drum (part of 16-037)	2
	16-723-01	Cylinder Kit (Includes Boot and Cup)	2 per side

1. For Left brake, assembly with star wheel of adjusting screw (Ref# 8) towards the front of the brake (as shown), opposite for Right brake.
2. Red Spring- Assemble to front of brake on right side assembly, opposite for left.
3. Green Spring - Assemble to rear of brake on right side assembly, opposite for left.
4. Brake actuating lever (Ref# 6) shown for right assembly, reverse for left assembly. Bent arm stays up, double arm switches to forward.

# 1602P PLUMBING DRAWING (RAVEN 440)

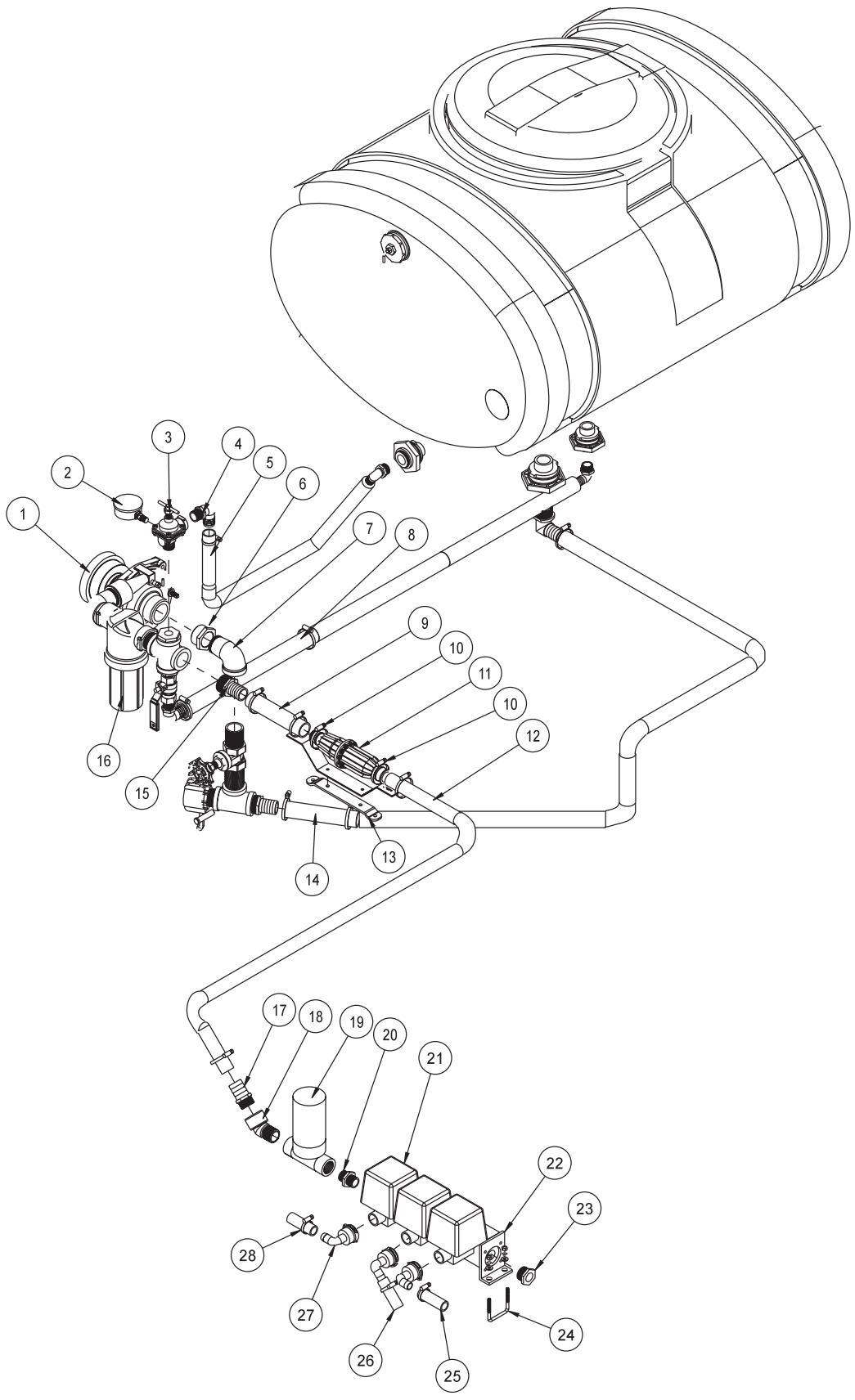

Accessories

## 1602P PLUMBING PARTS LIST

REF#	PART#	DESCRIPTION	QUANTITY
1	16-998	Hypro® Pump	1
2	16-281	Liquid Filled Gauge	1
3	16-034	Throttling Valve	1
	16-034-01	Spare Parts Kit (for 16-034)	1
4	16-155	Elbow 3/4 MPT x 1 HB	1
5	8896-33	Discharge Hose 1"	1
	18-222	Hose Clamp <sup>13</sup> / <sub>16</sub> x 1 1/2	2
6	16-825	Reducer Bushing 1 1/2 x 1 1/4	1
7	15-385	Elbow 1 1/4	2
8	8896-42	Discharge Hose 1"	1
	18-222	Hose Clamp <sup>13</sup> / <sub>16</sub> x 1 1/2	2
9	8897-15	Discharge Hose 1 1/4"	1
	18-116	Hose Clamp HS-24	2
10	18-116	Hose Clamp HS-24	2
11*	16-456	Flow Meter	1
	16-456-08	Mounting Bracket	1
12	8897-30	Discharge Hose 1 1/4	1
	18-116	Hose Clamp HS-24	2
13	15-327	Flow Meter Mount	1
	HB-516-18-100	Bolt <sup>5</sup> / <sub>16</sub> - 18 x 1	2
	HNTL-516-18	Lock Nut <sup>5</sup> / <sub>16</sub> - 18	2
14	8889-22	Suction Hose 1 1/4	1
	18-116	Hose Clamp HS-24	2
15	16-161	Fitting 1 1/4 MPT x 1 1/4 HB	1
16	14-371	Strainer	1
17	16-159	Fitting 1 MPT X 1 1/4 HB	1
18	16-971	45° Elbow 1 FPT x 1 MPT	1
19*	16-524	Motorized Control Valve	1
20	16-851	Reducer <sup>3</sup> / <sub>4</sub> FPT x 1 MPT	1
21	15-552	Manifold Ball Valve	1
22	15-552-07	Steel Mounting Bracket (comes with 15-552)	2
23	16-162	Pipe Plug	1
24	10-194	U-Bolt	2
	HNTL-14-20	Lock Nut <sup>1</sup> / <sub>4</sub> -20	4
	HW-14	Washer <sup>1</sup> / <sub>4</sub>	4
25	8887-36.5	Orange PVC Hose <sup>3</sup> / <sub>4</sub> x 34 1/2" (to right boom)	1
	18-040	Hose Clamp HS-12	1
26	8887-28	Orange PVC Hose <sup>3</sup> / <sub>4</sub> x 28" (to center boom)	1
	18-040	Hose Clamp HS-12	1
27	15-553	<sup>3</sup> / <sub>4</sub> - 90° Hose Barb (comes with 15-552)	3
	15-553-01	Clip	3
	15-553-02	O-Ring	3
28	8887-42	Orange PVC Hose <sup>3</sup> / <sub>4</sub> x 42" (to left boom)	1
	18-040	Hose Clamp HS-12	1
* *	15-365	Raven 440 Computer with Accessories (includes all * items)	

# 1604P PLUMBING DRAWING (RAVEN 203)

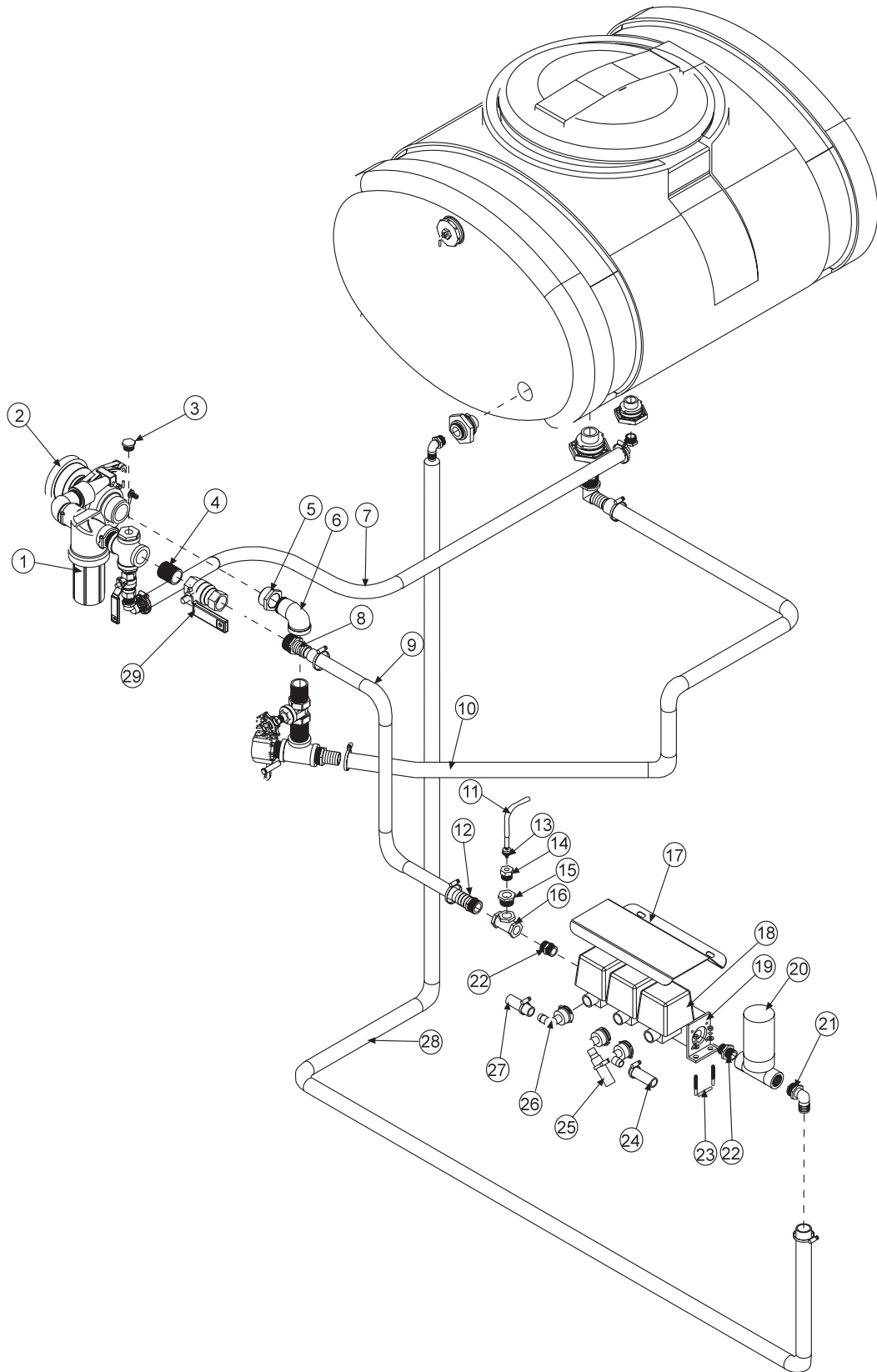

Accessories

# 1604P PLUMBING PARTS LIST

REF#	PART#	DESCRIPTION	QUANTITY
1	14-371	Strainer	1
2	16-998	Hypro® Pump	1
3	16-166	Hex Plug 3/4 MPT	1
4	18-160	Close Nipple 1 1/4"	1
5	16-825	Reducer Bushing 1 1/2 x 1 1/4	1
6	15-385	Elbow 1 1/4"	1
7	8896-42	Discharge Hose 1" x 42"	1
	18-222	Hose Clamp 13/16 x 1 1/2	2
8	16-161	Fitting 1 1/4 MPT x 1 1/4 HB	1
9	8897-50	Discharge Hose 1 1/4" x 50"	1
	18-116	Hose Clamp HS-24	2
10	8889-22	Suction Hose 1 1/4 x 22"	1
	18-116	Hose Clamp HS-24	2
11*	16-955	Tube	1
12	16-159	Fitting 1 MPT x 1 1/4 HB	1
13*	16-958-07	Male Fitting	1
14	16-288	Reducer Bushing 3/4 x 1/4	1
15	16-163	Reducer Bushing 1 x 3/4	1
16	16-183	Tee FPT 1 x 1 x 1	1
17	10-199	Shield	1
18	15-552	Manifold Ball Valve	1
19	15-552-07	Steel Mounting Bracket (comes with ball valve)	2
20*	16-995	Motorized Control Valve	1
21	16-164	Elbow 1 MPT x 1 HB	1
22	16-158	Close Nipple 3/4"	2
23	10-194	U- Bolt	2
	HW-14	Washer 1/4"	4
	HNTL-14-20	Lock Nut 1/4 - 20	4
24	8887-36.5	Orange PVC Hose 3/4" x 36 1/2" (to right boom)	1
	18-040	Hose Clamp HS-12	1
25	8887-28	Orange PVC Hose 3/4" x 28" (to center boom)	1
	18-040	Hose Clamp HS-12	1
26	15-553	Hose Barb 3/4 - 90° (comes with ball valve)	3
	15-553-01	Clip (part of 15-553)	3
	15-553-02	O-ring (part of 15-553)	3
27	8887-42	Orange PVC Hose 3/4" x 42" (to left Boom)	1
	18-040	Hose Clamp HS-12	1
28	8896-70	Discharge Hose 1" x 70"	1
	18-222	Hose Clamp 13/16 x 1 1/4	2
29	18-279	Ball Valve 1 1/4"	1

\* 16-852 Raven 203 Computer with Accessories (all \* items)

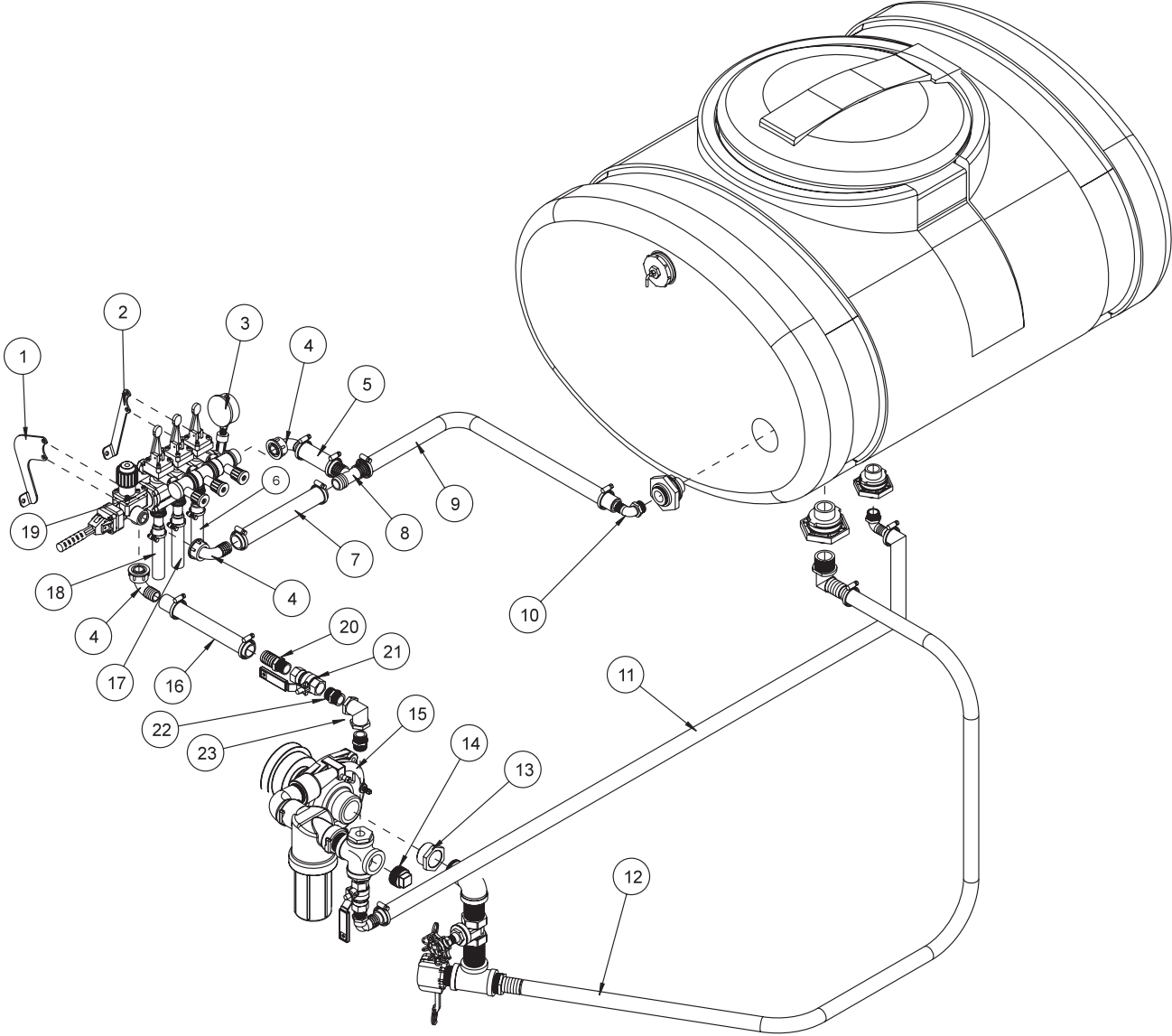

Accessories

## 1610P PLUMBING PARTS LIST

REF#	PART#	DESCRIPTION	QUANTITY
1	10-263	Front Valve Bracket	1
2	10-264	Rear Valve Bracket	1
3	16-281	Liquid Filled Gauge	1
4	16-268-13	90° Elbo x 1HB with Nut (comes with 10-268 Valve)	3
5	8896-4	Discharge Hose 1" x 4"	1
	18-222	Hose Clamp <sup>13</sup> / <sub>16</sub> x 1 <sup>1</sup> / <sub>2</sub>	2
6	8887-122	Orange PVC Hose <sup>3</sup> / <sub>4</sub> " x 122" (right boom)	1
	18-040	Hose Clamp HS-12	1
7	8896-10	Discharge Hose 1" x 10"	1
	18-222	Hose Clamp <sup>13</sup> / <sub>16</sub> x 1 <sup>1</sup> / <sub>2</sub>	2
8	10-269	Plastic Tee 1 x 1 x 1HB	1
9	8896-20	Discharge Hose 1" x 20"	1
	18-222	Hose Clamp <sup>13</sup> / <sub>16</sub> x 1 <sup>1</sup> / <sub>2</sub>	2
10	16-155	Elbow <sup>3</sup> / <sub>4</sub> MPT x 1 HB	1
11	8896-42	Discharge Hose 1" x 42"	1
	18-222	Hose Clamp <sup>13</sup> / <sub>16</sub> x 1 <sup>1</sup> / <sub>2</sub>	2
12	8889-22	Suction Hose 1 <sup>1</sup> / <sub>4</sub> " x 22"	1
	18-116	Hose Clamp HS-24	2
13	16-825	Reducer Bushing 1 <sup>1</sup> / <sub>2</sub> x 1 <sup>1</sup> / <sub>4</sub>	1
14	18-098	Pipe Plug	1
15	16-998	Hypro® Pump	1
16	8896-32.5	Discharge Hose 1" x 32 <sup>1</sup> / <sub>2</sub> "	1
	18-222	Hose Clamp <sup>13</sup> / <sub>16</sub> x 1 <sup>1</sup> / <sub>2</sub>	2
17	8887-109	Orange PVC Hose <sup>3</sup> / <sub>4</sub> " x 109" (center boom)	1
	18-040	Hose Clamp HS-12	1
18	8887-130	Orange PVC Hose <sup>3</sup> / <sub>4</sub> " x 130" (left boom)	1
	18-040	Hose Clamp HS-12	1
19	10-268	3 Way Manual Valve	1
20	16-196	Hose Barb <sup>3</sup> / <sub>4</sub> MPT x 1 HB	1
21	16-859	Ball Valve <sup>3</sup> / <sub>4</sub> Brass	1
22	16-158	Close Nipple <sup>3</sup> / <sub>4</sub>	2
23	16-151	Elbow FPT <sup>3</sup> / <sub>4</sub>	1

# CONTROLS 1602P SYSTEM DRAWING (RAVEN 440)

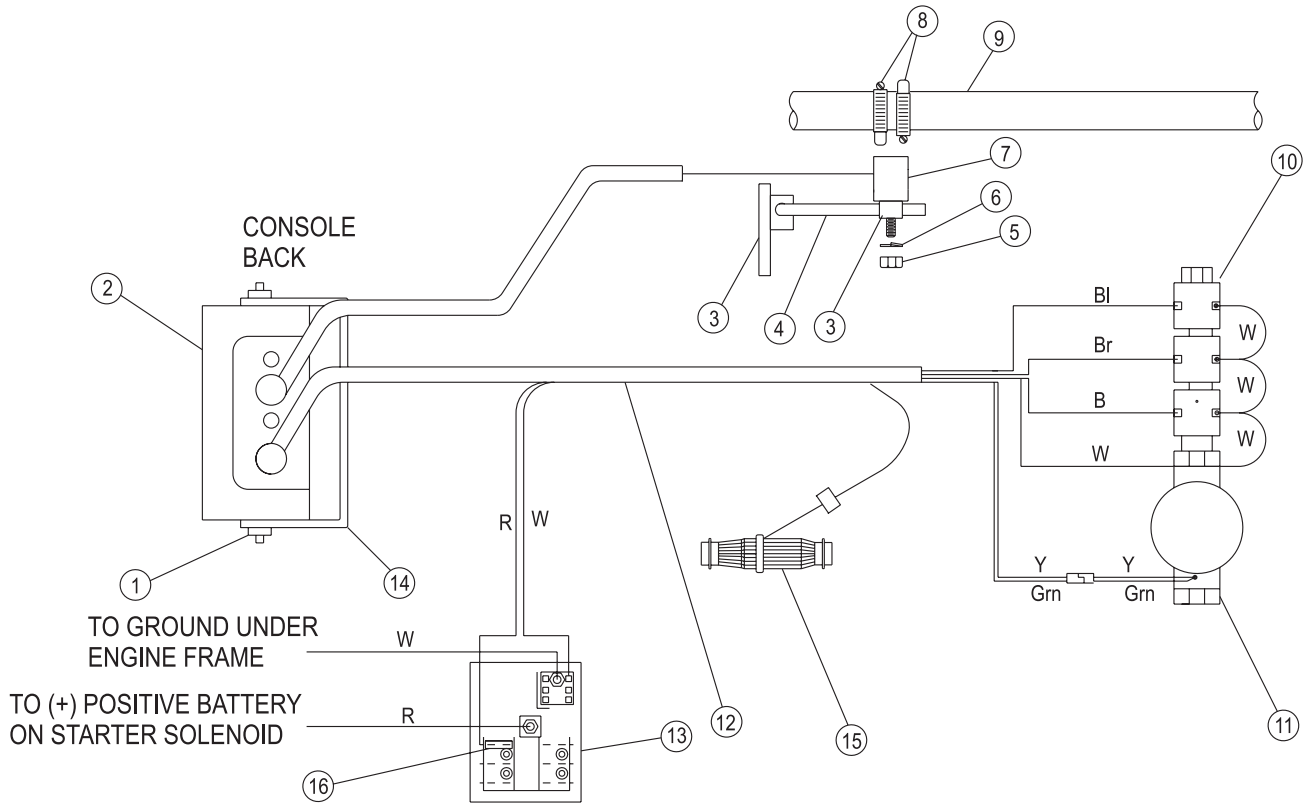

# CONTROL 1604P SYSTEM DRAWING (RAVEN 203)

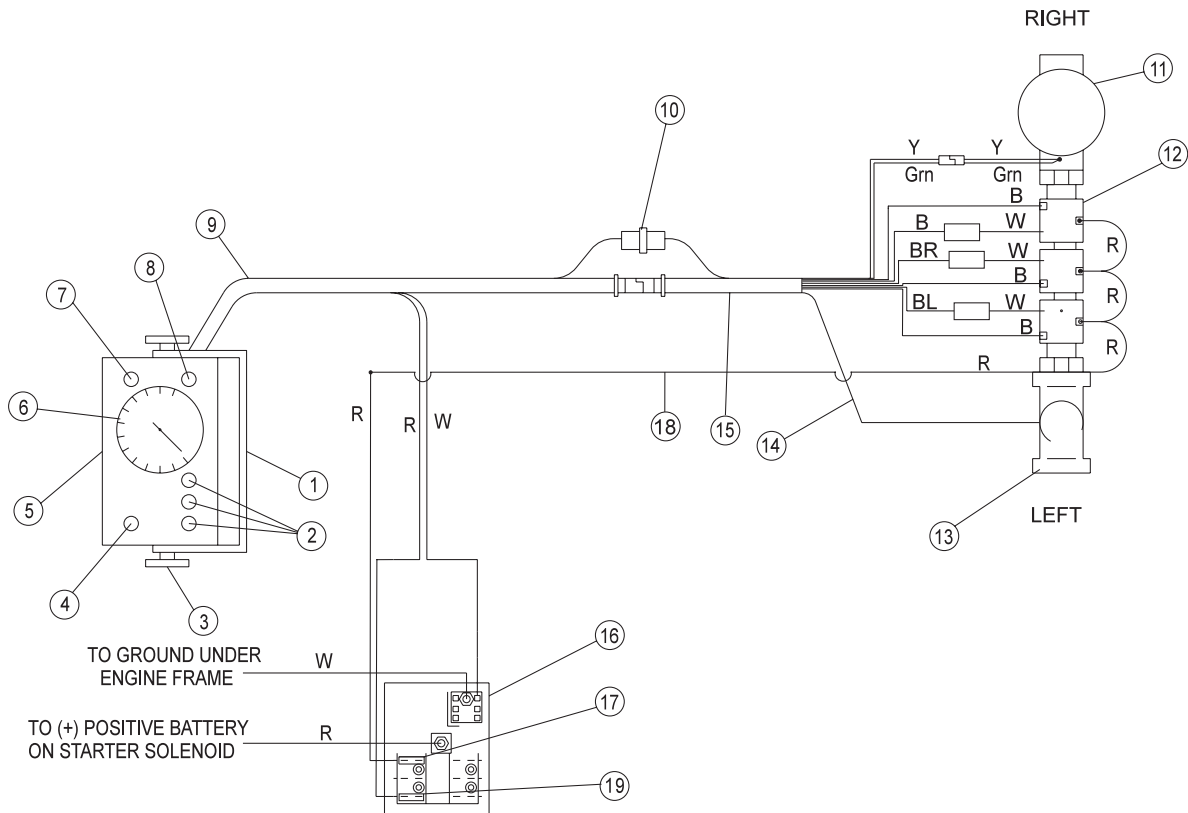

Accessories



## CONTROLS 1602P SYSTEM PARTS LIST

REF#	PART#	DESCRIPTION	QUANTITY
1	16-558	Mounting Knob	2
2	16-525	Console (only)	1
	16-234	Computer Cover	1
3*	15-370-03	Turret Assembly	2
4*	15-370-04	Speed Sensor Rod	1
5*	HN-14-20	Nut 1/4 - 20	2
6*	HWL-14	Lockwasher 1/4	2
7	16-457	Magnetic Sensor	1
8*	15-370-01	Red Magnet Assembly north	1
*	15-370-02	Black Magnet Assembly south	1
*	15-370-07	Small Band Clamp	2
9	14-370	Drive Line (Spray Star)	1
10	14-348	Solenoid Valve	1
11	16-524	Motorized Control Valve	1
12	15-369	Console Control Cable	1
13	33-271	Fuse Block	1
14	10-237	Mounting Bracket	1
15	16-456	Flow Meter	1
16	33-508	Auto Blade Type Fuse 15 amp	1
*	15-370-08	Drive Shaft Hardware Kit (for speed sensor)	

*Use Dielectric Grease On All Electrical Connections*

## CONTROL 1604P SYSTEM PARTS LIST

REF#	PART#	DESCRIPTION	QUANTITY
1*	16-958-01	Mounting Bracket	1
2	16-898	Boom Switch	3
3	16-900	Mounting Knob	2
4	16-899	Master Switch	1
5*	16-958	Console (only)	1
6	33-090-02	Liquid Filled Pressure Gauge	1
7	16-958-02	Fuse Holder	1
	16-525-03	Fuse 15 AMP	1
8	16-895	Pressure Switch	1
9*	16-958-04	Cable Assembly 8ft Enclosure Hook-Up	1
10*	16-958-05	Union Fitting	1
11*	16-995	Motorized Control Valve	1
12	15-552	Manifold Ball Valve	1
13	16-183	Tee FPT 1 x 1 x 1	1
14*	16-955	Tubing	1
15*	16-902	Cable Assembly 72" Solenoid Hook-Up	1
16	33-271	Fuse Block	1
17	33-284	Auto Blade Type Fuse 5 amp	1
18	10-225	Wire Harness (fuse block to electric valve)	1
19	33-508	Auto Blade Type Fuse 15 Amp	1
*	16-852	203 Sprayer Control Kit (includes all * items)	

*Use Dielectric Grease On All Electrical Connections*

# 15-515 FLOW METER DRAWING

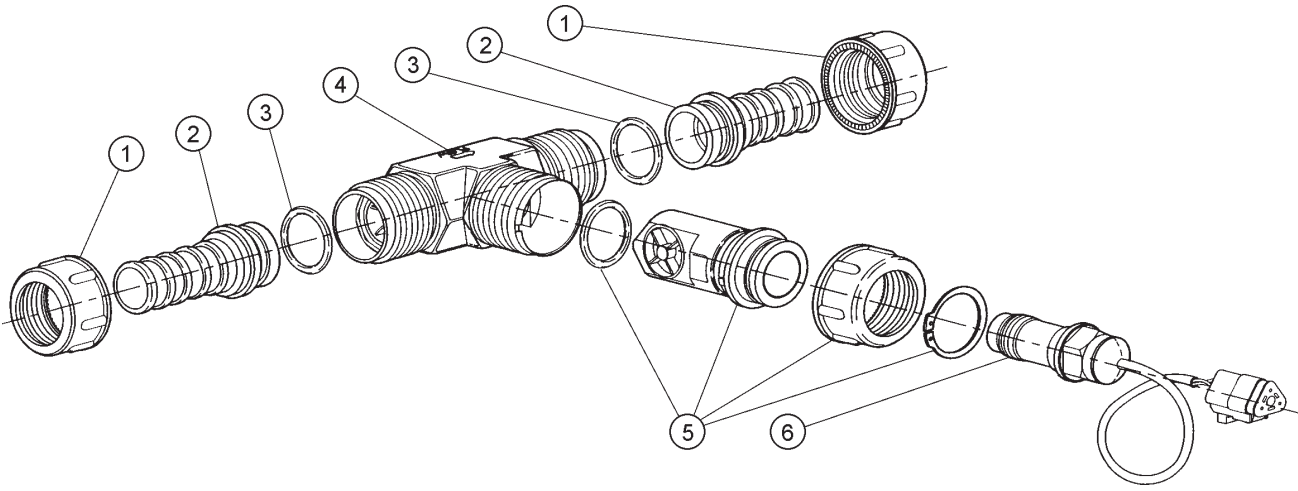

Accessories

## 15-515 FLOW METER PARTS LIST

REF#	PART#	DESCRIPTION	QUANTITY
1*	15-515-02	Nylon Ring Nut	2
2*	15-515-03	Nylon Hose Barb	2
3*	15-515-04	Viton O-ring	2
4	15-515-05	Flow Meter Body	1
5	15-515-06	Turbine Insert Assembly	1
6	15-515-07	Flow Meter Pickup	1
*	15-515-01	Hose Barb Assembly	

**16-524 AND 16-995 MOTORIZED CONTROL VALVE DRAWING**

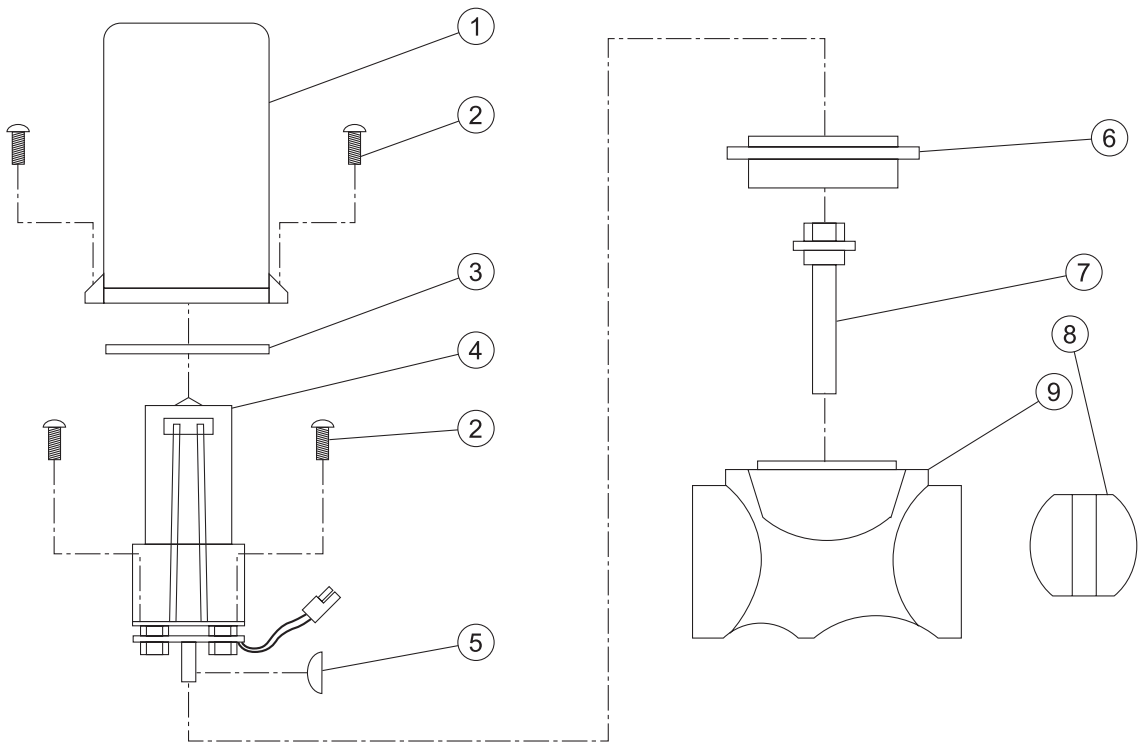

**16-456 FLOW METER DRAWING**

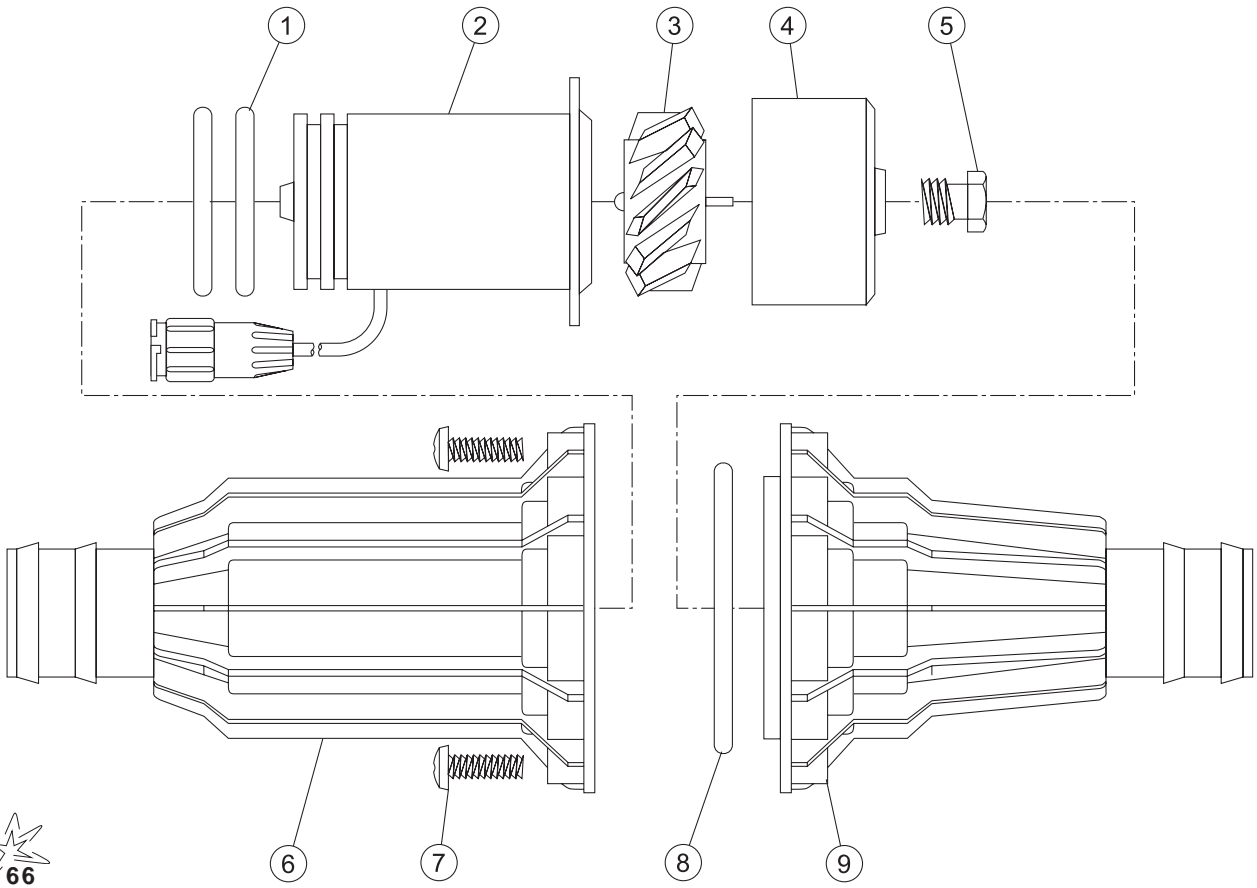

Accessories

## 16-524 AND 16-995 MOTORIZED CONTROL VALVE PARTS LIST

REF#	PART#	DESCRIPTION	QUANTITY
1	16-870	Valve Cover	1
2*	16-524-01	#6 Self Tapping Screw 3/4" Long	6
3	16-897	Seal Tetraseal	1
4	16-875	Motor Assembly (For 16-524 on Spray Star 3002)	1
4	16-866-01	Motor Assembly (For 16-866 on Spray Star 3004)	1
5*	16-957	Woodruff Key	1
6*	16-524-04	Isolation Flange Assembly	1
7*	16-524-02	Coupler Shaft	1
8*	16-956	Butterfly	1
9*	16-524-03	Valve Body Assembly (for 16-524)	1
	16-995-01	Valve Body Assembly (for 16-995)	1
10	16-995-01		
*	16-524-05	1" Valve ISO-Body Kit (for 15-524)	
	16-955-02	1" Valve ISO-Body Kit (for 16-995)	

### WHEN SERVICING VALVE:

Replace valve body with ISO-Body Kit if valve has been leaking internally.

Replace motor assembly if the motor will not run or if the printed circuit board is corroded.

Before reassembling valve, remove the coupler shaft from the valve body. Apply Loctite to coupler shaft and woodruff key. Place the coupler shaft (Ref 7) and the woodruff key (Ref 5) onto the motor shaft. Plug motor into the valve connector coming from Sprayer Control Console. Check that the motor rotates in both directions. Motor must stop when coupler CAM releases printed circuit board switch button.

When reassembling valve, grease both sealing surfaces of coupler shaft. Insert coupler shaft into Iso-flange and be sure seal properly seats on shaft. Install on valve body and apply RTV 738 to mounting holes. Reassemble remaining items as shown in parts diagram on opposite side.

## 16-456 FLOWMETER PARTS LIST

REF#	PART#	DESCRIPTION	QUANTITY
1*	16-456-03	O-Ring Viton	2
2*	16-456-04	RFM55 dual O-Ring XDCR assembly	1
3	16-456-05	RFM55 turbine	1
4	16-456-06	Turbine hub/bearing assembly	1
5	16-143	Turbine stud assembly	1
6	16-456-01	Sensor housing	1
7	16-456-02	#10-32 x 3/4 stainless steel screw	12
8	16-144	O-Ring Viton	1
9	16-456-07	Hub housing with inserts	1
	16-456-08	Mounting bracket RFM 55	1
	16-456-09	Thread sealer	1
*	16-456-10	O-Ring Transducer Kit	

# 10-268 3-WAY MANUAL VALVE DRAWING

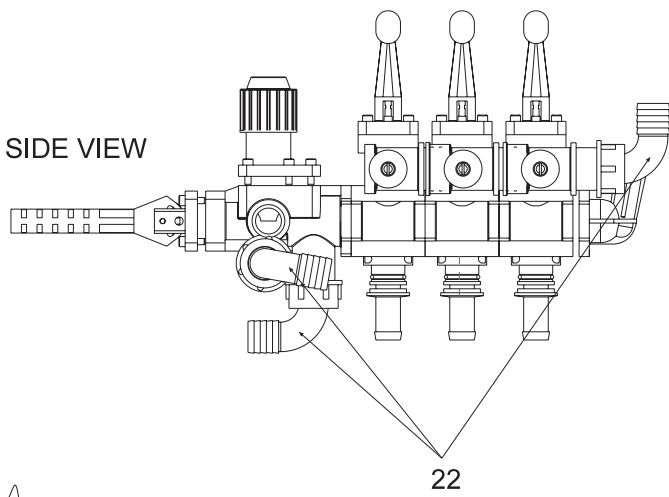
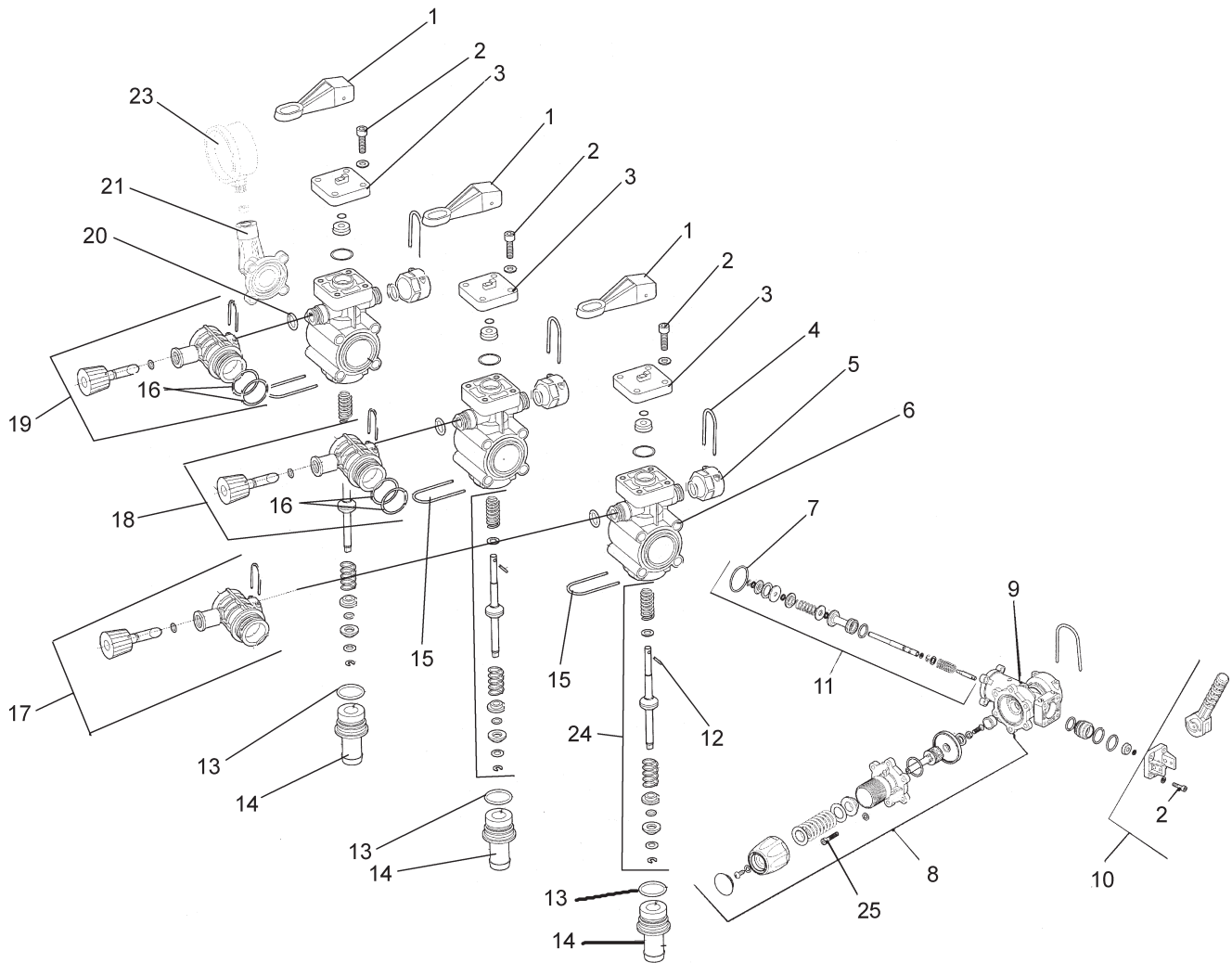

Accessories

## 10-268 3-WAY MANUAL VALVE PARTS LIST

REF#	PART#	DESCRIPTION	QUANTITY
1	10-268-07	Boom Lever	3
2	10-268-16	Bolt and Washer	18
3	10-268-17	Boom Lever Plate	3
4	10-268-06	Spring Clip <sup>5/8</sup>	6
5	10-268-05	Cap	3
	10-268-21	O-Ring(included with 10-268-19 Seal Kit)	3
6	10-268-02	Main Body	3
	10-268-19	Seal Kit	1 per body
7	10-268-24	O-Ring for Main Body	3
8	10-268-27	Main Pressure Adjust	1
9	10-268-29	Pressure Adjust Body	1
10	10-268-09	Main Boom Lever	1
11	10-268-30	Master Boom Lever Guts	1
12	10-268-25	Boom Lever Pin	3
13	10-268-22	O-Ring(included with 10-268-19 Seal Kit)	3
14	10-268-03	Hose Barb <sup>3/4</sup>	3
15	10-268-04	Spring Clip <sup>7/8</sup>	3
16	10-268-23	O-Ring(included with 10-268-12 and 10-268-14)	4
17	10-268-11	Boom Pressure Adjust(threaded end)	1
18	10-268-12	Boom Pressure Adjust(middle)	1
19	10-268-14	Boom Pressure Adjust(capped)	1
20	10-268-21	O-Ring	3
21	10-268-01	Gage Elbow	1
22	10-268-13	Elbow 90° 1" Hose Barb w/ Nut	3
23	16-281	Liquid Filled Gauge(not included with 10-268 valve)	1
24	10-268-26	Boom Lever Guts	3
25	10-268-28	Bolt & Washer	6
Not Shown	10-268-15	Tie Rod with Nuts and Washer	4

# 14-348 SOLENOID VALVE DRAWING

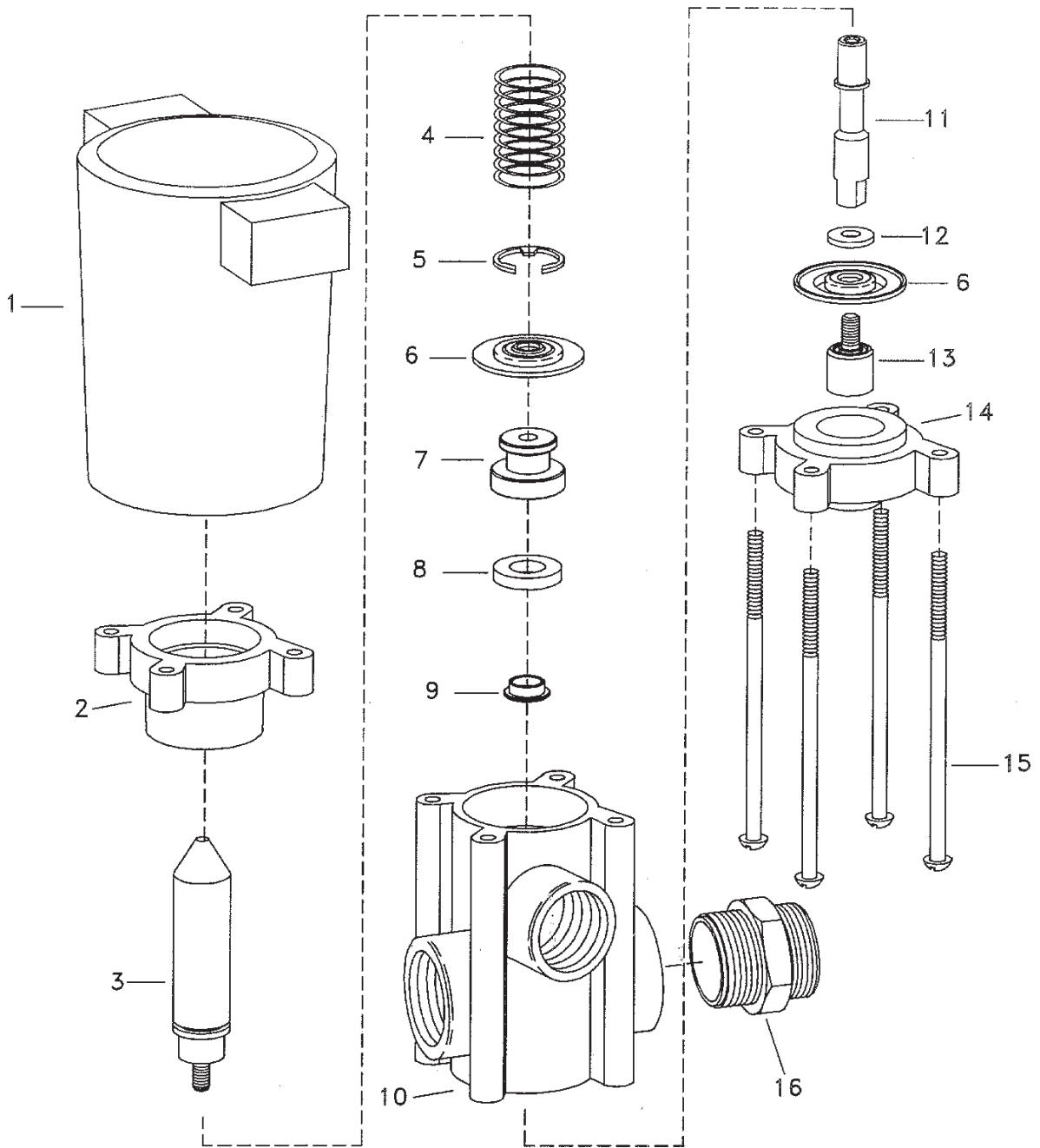

Accessories



## 14-348 SOLENOID PARTS LIST

REF#	PART#	DESCRIPTION	QUANTITY
1	14-348-02	Coil Assembly	1
2	16-879-07	Upper Diaphragm Housing	1
3	14-348-03	Armature, Type 430fr Stainless Steel	1
4*	14-348-04	Spring, Type 302 Stainless Steel	1
5	14-348-05	Retaining Ring, Steel	1
6*	16-879-11	Diaphragm, Viton Rubber	1
7	14-348-06	Seat Washer Retainer, Stainless Steel	1
8*	14-348-07	Seat Washer, Viton Rubber	2
9	14-348-08	Spacer, Stainless Steel	1
10	14-348-09	Body, Polypropylene (Black)	1
11	14-348-10	Stem, Stainless Steel	1
12	14-348-11	Washer, Stainless Steel	1
13	16-879-12	Lower Diaphragm Piston, Stainless Steel	1
14	16-879-13	Lower Diaphragm Housing	1
15	14-348-12	Screw, Stainless Steel	4
16	16-879-14	Connecting Nipple, Nylon (Black)	1
	14-348-01	Single Unit	3
*	14-348-13	Spare Parts Kit	1

# 10-300 18' TERRAIN FOLLOWING BOOM DRAWING

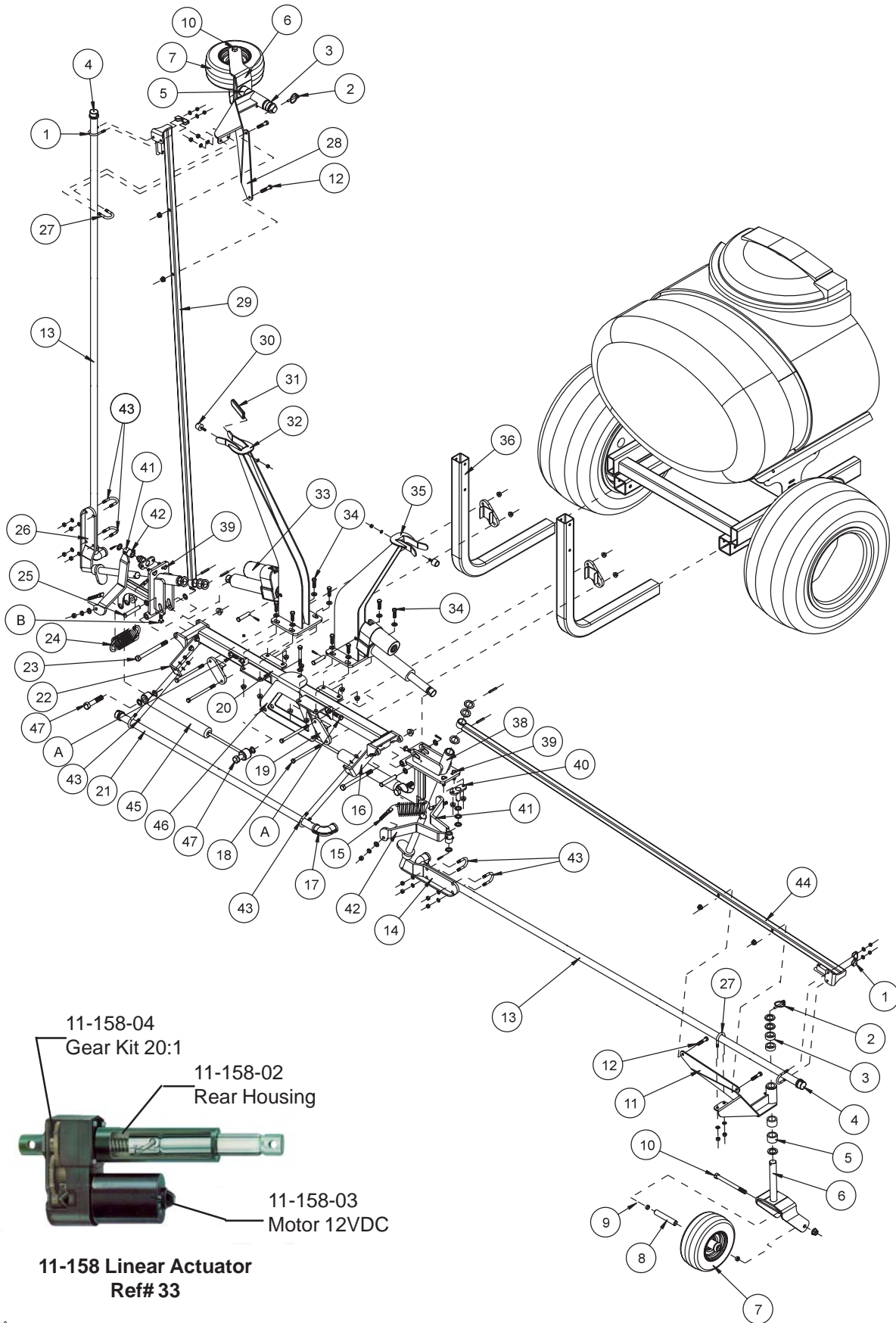

Accessories



**11-158 Linear Actuator  
Ref# 33**

## 10-300 18' TERRAIN FOLLOWING BOOM PARTS LIST

REF#	PART#	DESCRIPTION	QUANTITY
1	13-498	Muffler Clamp 1 <sup>1/8</sup>	2
	HWL-516	Lockwasher 5/16	4
	HN-516-18	Nut 5/16 - 18 (part of 13-498)	4
2	42-539	Lynch Pin 1/4	2
3	29-584	1/2" Spacer	4
4	16-926	Stainless Steel Cap	3
5	29-585	1" Spacer	4
6	10-312	Castor Fork	2
	HMB-100-10	Machine Bushing 1 x 10GA (3 per fork)	6
7	42-202	Tire and Wheel	2
	42-202-01	Tire	2
	42-202-02	Wheel	2
8	42-213	Axle Bearing	2
9	42-212	Castor Wheel Spacer	4
10	HBS-12-13-600	Stainless Steel Bolt 1/2 - 13 x 6	2
	HNTL-12-13	Lock Nut 1/2 - 13	2
11	10-310	Right Castor Wheel Bracket	1
	18-035	Bushing (part of 10-310)	2
	HG-14-28-180	Grease Fitting 1/4 - 28 x 180° (part of 10-310)	1
12	HBS-38-16-175	Stainless Steel Bolt 3/8 - 16 x 1 <sup>3/4</sup>	4
	HNTL-38-16	Lock Nut 3/8 - 16	4
13	16-928	Right and Left Tube	2
14	33-301	Right Pivot Bracket	1
	HMBS-100-10	Stainless Steel Machine Bushing 1 x 10GA	1
	HMBS-100-14	Stainless Steel Machine Bushing 1 x 14GA	2
	HRPS-14-150	Stainless Steel Roll Pin 1/4 x 1 <sup>1/2</sup>	2
	42-537	Spade Bolt 3/8 - 16	4
15	HW-38	Washer 3/8	4
	HWL-38	Lockwasher 3/8	4
	HN-38-16	Nut 3/8 - 16	4
	33-308	Right Center Tube Mount	1
16	HBS-38-16-125	Stainless Steel Bolt 3/8 - 16 x 1 <sup>1/4</sup>	2
	HWS-38	Stainless Steel Washer 3/8	2
	HNTL-38-16	Lock Nut 3/8 - 16	2
17	16-925	Stainless Steel Pipe Elbow 3/4 x 90°	3
	18-249	Barb Fitting	3
	18-040	Hose Clamp HS-12	3
18	HBS-38-16-550	Stainless Steel Bolt 3/8 - 16 x 5 <sup>1/2</sup>	4
	HNTL-38-16	Lock Nut 3/8 - 16	4
19	10-304	Boom Bracket	4
20	10-305	Center Boom Mount	1
21	16-927	Center Tube	1
A	HSSQS-38-16-150	Stainless Steel Set Screw 3/8 - 16 x 1 <sup>1/2</sup> (part of 10-305)	2
	HN-38-16	Nut 3/8 - 16 (part of 10-305)	2
22	33-309	Left Center Tube Mount	1
	HBS-38-16-125	Stainless Steel Bolt 3/8 - 16 x 1 <sup>1/4</sup>	2
	HWS-38	Stainless Steel Washer 3/8	2
	HNTL-38-16	Lock Nut 3/8 - 16	2
23	HBS-12-13-600	Stainless Steel Bolt 1/2 - 13 x 6	2
	HNTL-12-13	Lock Nut 1/2 - 13	2
24	10-313	Extension Spring	2
25	HCPS-12-275	Stainless Steel Clevis Pin 1/2 x 2 <sup>3/4</sup>	2
	HMB-12-14	Machine Bushing 1/2 x 14GA	4
	HPS-18-100	Stainless Steel Cotter Pin 1/8 x 1	2

(Continue on Next Page)

# 10-300 18' TERRAIN FOLLOWING BOOM DRAWING

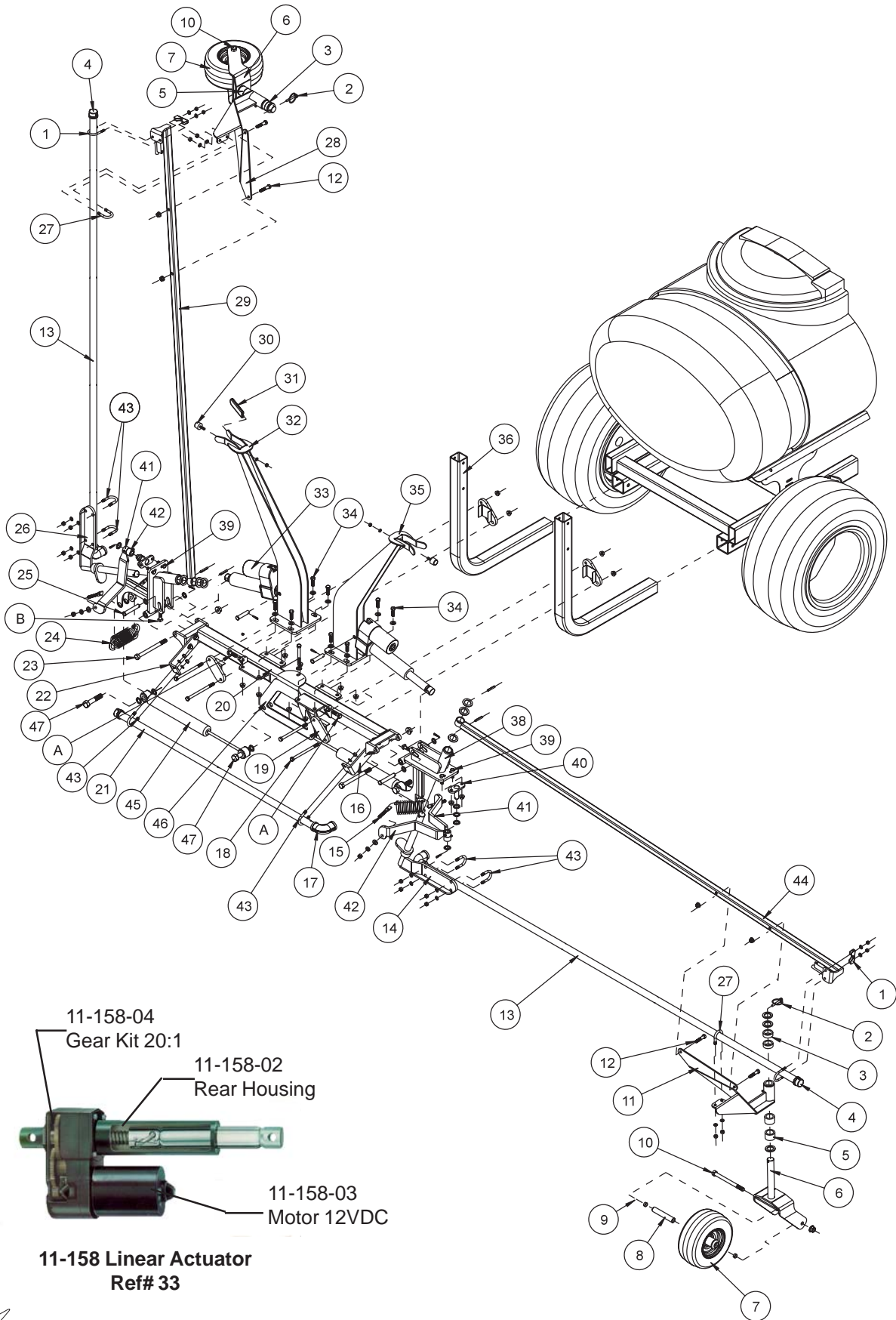

Accessories

## 10-300 18' TERRAIN FOLLOWING BOOM PARTS LIST

REF#	PART#	DESCRIPTION	QUANTITY
26	33-302	Left Pivot Bracket	1
	HMBS-100-10	Stainless Steel Machine Bushing 1 x 10GA	1
	HMBS-100-14	Stainless Steel Machine Bushing 1 x 14GA	2
	HRPS-14-150	Stainless Steel Roll Pin 1/4 x 1 1/2	2
27	16-024	U-Bolt 5/16 - 24	2
	HWLS-516	Stainless Steel Lockwasher 5/16	4
	HNS-516-24	Stainless Steel Nut 5/16 - 24	4
28	10-311	Left Castor Wheel Bracket	1
	18-035	Bushing (part of 10-311)	2
	HG-14-28-180	Grease Fitting 1/4 - 2 8 x 180° (part of 10-311)	1
29	10-307	Left Brush Guard	1
30	15-013	Rubber Bumper	2
	HWL-14	Lockwasher 1/4	2
	HN-14-20	Nut 1/4 - 20	2
31	10-318	Grip Pad	4
32	10-316	Left Boom Holder	1
33	11-158	Linear Actuator	2
	HCPS-12-200	Stainless Steel Clevis Pin 1/2 x 2	2
	HPS-18-100	Stainless Steel Cotter Pin 1/8 x 1	2
34	HBS-38-16-125	Stainless Steel Bolt 3/8 - 16 x 1 1/4	8
	HWS-38	Stainless Steel Washer 3/8	8
	HNTL-38-16	Lock Nut 3/8 - 16	8
35	10-317	Right Boom Holder	1
36		Boom Carrier (part of machine)	
38	10-330	Pivot Bracket	2
	15-494	Nylon Flange Bushing 1" ID (2 per 10-330)	4
	18-036	Oilite Bushing 1/2 ID (2 per 10-330)	4
	HG-14-28-180	Grease Fitting 1/4 - 28 x 180° (2 per 10-330)	4
	HN-38-16	Nut 3/8 - 16 (1 per 10-330)	2
B	HSSQS-38-16-150	Stainless Steel Set Screw 3/8 - 16 x 1 1/2 (1 per 10-330)	2
39	HBS-38-16-125	Stainless Steel Bolt 3/8 - 16 x 1 1/4	4
	HWS-38	Stainless Steel Washer 3/8	4
	HNTL-38-16	Lock Nut 3/8 - 16	4
40	10-303	Pivot	2
	HMBS-58-14	Stainless Steel Machine Bushing 5/8 x 14GA	8
	HPS-18-100	Stainless Steel Cotter Pin 1/8 x 1	2
41	10-309	Left Cam Stop (must also order 10-308)	2
	18-268	Oilite Bushing (part of 10-309)	2
	HG-14-28-180	Grease Fitting 1/4 - 28 x 180° (part of 10-309)	2
42	10-308	Right Cam Stop (must also order 10-309)	2
	18-268	Oilite Bushing (part of 10-308)	2
	HG-14-28-180	Grease Fitting 1/4 - 28 x 180° (part of 10-308)	2
43	16-024	U-Bolt 5/16 - 24	6
	HWLS-516	Stainless Steel Lockwasher 5/16	12
	HNS-516-24	Stainless Steel Nut 5/16 - 24	12
44	10-306	Right Brush Guard	1
45	10-332	Stabilizer	2
46	10-331	Center Stabilizer Mount	1
	HB-38-16-300	Bolt 3/8 - 16 x 3	1
	HW-38	Washer 3/8	2
	HNTL-38-16	Lock Nut 3/8 - 16	1
47	HB-58-11-300	Bolt 5/8 - 11 x 3	4
	HMB-58-14	Machine Bushing 5/8 x 14GA	8
	HNTL-58-11	Lock Nut 5/8 - 11	4

# 10-300 18' TERRAIN FOLLOWING BOOM DRAWING

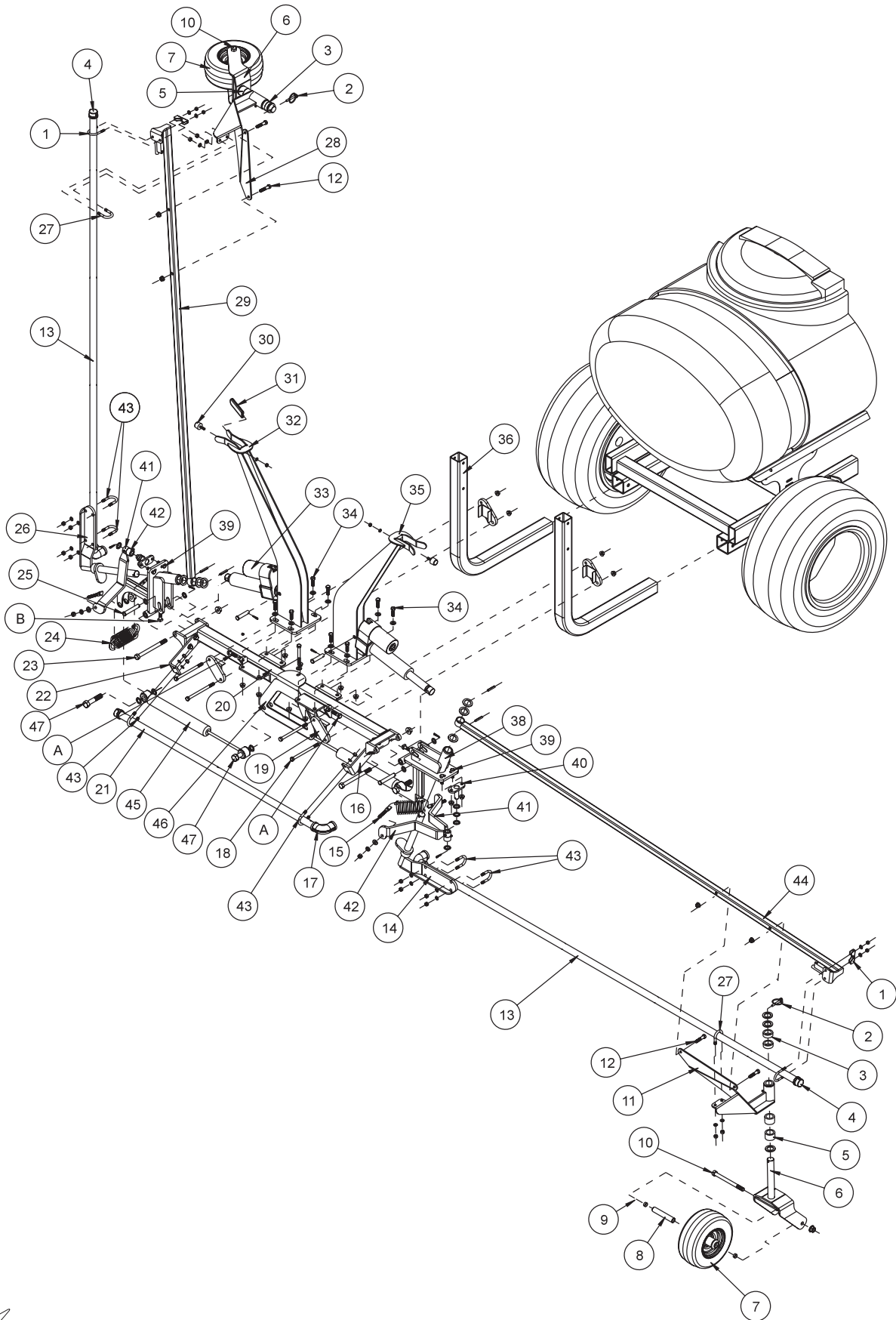

Accessories

For best results use Teflon® Tape on all fittings.

1. The three boom assemblies are not on the packing list but are in carton. You can NOT order these boom assemblies as one unit. Please refer to parts drawing for individual parts. The long boom assemblies are the right and left booms. The labels are located on right and left pivot brackets (Ref 14 and 26). The small boom assembly is the center boom. Each assembly is shipped with the nozzle bodies (16-996). The remainder parts of the nozzles need to be installed.
2. Mount small boom assembly to the boom carriers on sprayer, using the four boom brackets (Ref 19), four  $\frac{3}{8}$  - 16 x 5 $\frac{1}{2}$  bolts and lock nuts (Ref 18). One boom bracket should go on boom assembly and one on boom carrier. Do the same for right and left side. Place boom at desired level (approximately 20" (51 cm) and be sure it is centered. Tighten bolts.
3. Put the boom holders (Ref 32 and 35) on the center mount (Ref 20) using  $\frac{3}{8}$  - 16 x 1 $\frac{1}{4}$  bolts, washers and lock nuts (Ref 34), with washers next to slots. Center the bolts in the slots and tighten. The set screws (Ref A) on the center mount should be tightened to the stop. It is used to set the up and down movement of the boom at the castor wheel. **The range of the boom is approximately 32" total (16" up and 16" down).** This can be adjusted by moving the boom holders. In will increase the up range. Out will increase the down range.
4. Take right boom and slide pivot bracket (Ref 38) in the center mount (Ref 20) and hold in place with  $\frac{1}{2}$  - 13 x 6 bolt and lock nut (Ref 23). Do not over tighten, boom must be able to move up and down. Repeat for left boom. Yu may need to loosen the pivot (Ref 40) to install  $\frac{1}{2}$  - 13 x 6 bolt due to interference with the cam stops (Ref 41 and 42).
5. Mount the actuator (Ref 33) with the fixed end to the right and left boom holders (Ref 35 and 32) using  $\frac{1}{2}$  x 2 clevis pin and cotter pin. Mount the ram end to the pivot brackets (Ref 38) using  $\frac{1}{2}$  x 2 $\frac{3}{4}$  clevis pin and cotter pin (Ref 25) with the  $\frac{1}{2}$  x 14GA machine bushing on the outside of the pivot brackets.
6. Hook hoses to the respective fittings using hose clamps (18-040). The hose coming from the right side of the sprayer goes to the straight fitting on the right boom. The center hose from the sprayer goes to the straight fitting on the center boom. The left hose from the sprayer goes to the straight fitting on the left boom. Be sure all hose clamps are tight.
7. Now install the wiring harness. Refer to the wiring diagram.
8. Lower the booms so that the ends are at a height that you can work at.
9. Put the left castor wheel bracket (Ref 28) onto the left boom as shown. Using two  $\frac{3}{8}$  - 16 x 1 $\frac{3}{4}$  bolts and lock nuts (Ref 12) and one u-bolt, two  $\frac{5}{16}$  stainless steel lockwashers and stainless steel  $\frac{5}{16}$  - 24 nuts (Ref 27). Repeat for the right boom with the right castor wheel bracket (Ref 11) using the same hardware.
10. Put the assembled castor forks into the castor wheel brackets, adjusting the spacers to get the boom height you desire.
11. Make certain set screws (Ref B) on both sides are completely screwed in. Raise booms with boom switches all the way up. Adjust set screws (Ref B) so they contact the stop and lock.
12. Install center stabilizer mount (Ref 45) onto center boom (Ref 20) with the  $\frac{3}{8}$  - 16 x 3 bolt, washers and lock nuts.
13. Place stabilizers (Ref 46) into pivot brackets (Ref 38) with  $\frac{5}{8}$  - 11 x 3 bolts, machine bushings and lock nuts (Ref 47). Place rod end of stabilizers into center stabilizer mount. Make sure all bolts are tight.

## NOTE:

We do not recommend putting these booms into the forward position.

# 15-493 STAINLESS STEEL 18' AUTO BOOM DRAWING

8887-55	Orange Hose (Right & Left Booms)	2
8887-40	Orange Hose Center Boom	1
18-040	Hose Clamps	6

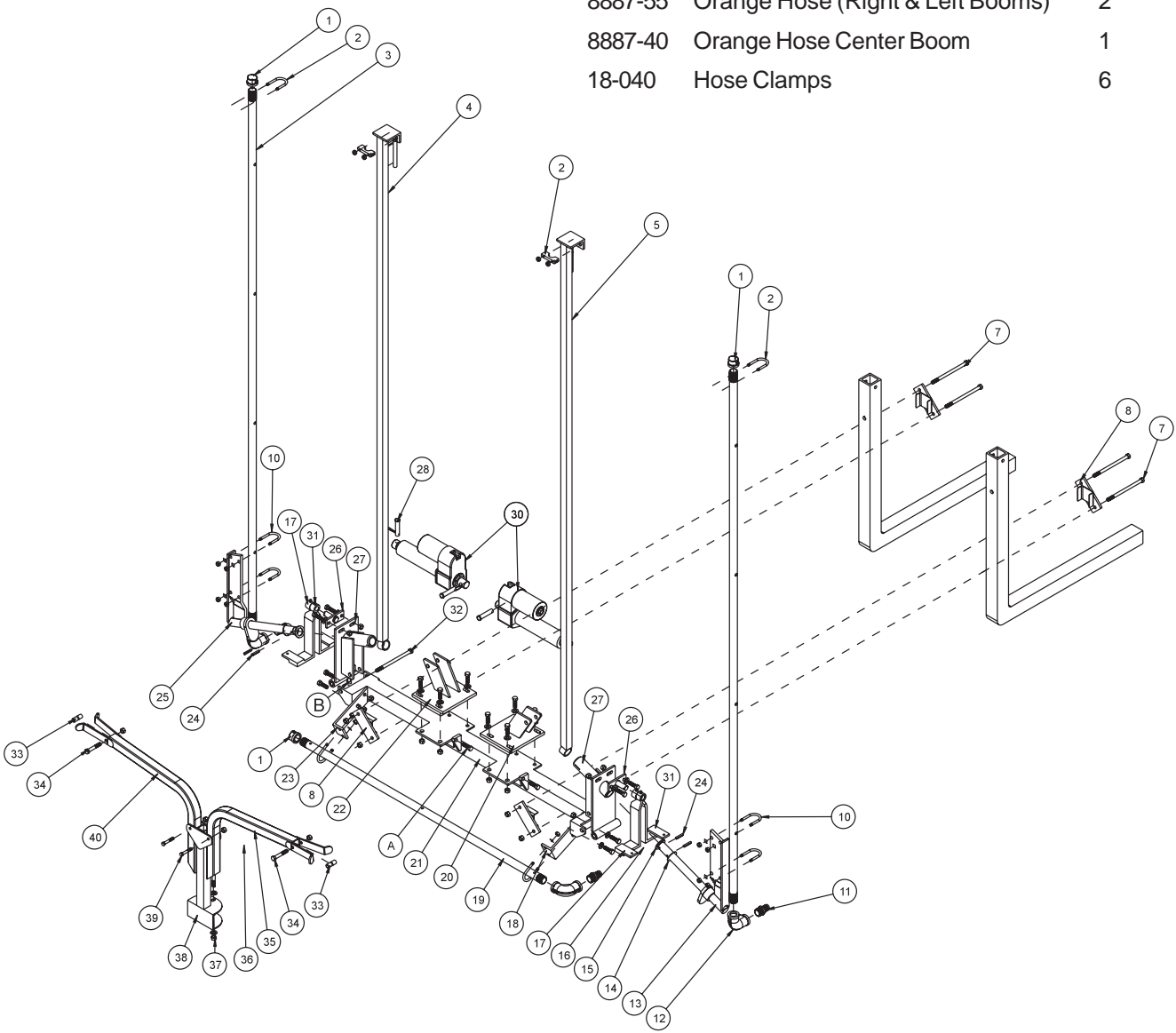

Accessories

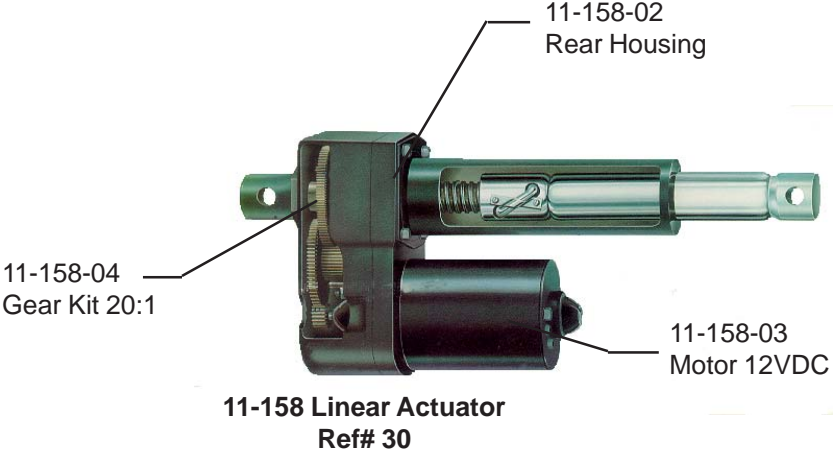



## 15-493 STAINLESS STEEL 18' AUTO BOOM PARTS LIST

REF#	PART#	DESCRIPTION	QUANTITY
1	16-926	Stainless Steel Cap <sup>3</sup> / <sub>4</sub>	3
2	13-498	U-Bolt Kit 1 <sup>1</sup> / <sub>8</sub>	2
3	16-928	Right and Left Tube	2
4	33-333	Left Brush Guard	1
5	33-332	Right Brush Guard	1
7	HBS-38-16-550	Stainless Steel Bolt <sup>3</sup> / <sub>8</sub> - 16 x 5 <sup>1</sup> / <sub>2</sub>	4
	HNTL-38-16	Lock Nut <sup>3</sup> / <sub>8</sub> - 16	4
8	16-761	Boom Brackets	4
10	16-024	U-Bolt <sup>5</sup> / <sub>16</sub> - 24	6
	HWLS-516	Stainless Steel Lockwasher <sup>5</sup> / <sub>16</sub>	12
	HNS-516-24	Stainless Steel Nut <sup>5</sup> / <sub>16</sub> - 24	6
11	18-249	Barb Fitting	3
12	16-925	Stainless Steel Pipe Elbow <sup>3</sup> / <sub>4</sub> x 90°	3
13	33-301	Right Pivot Bracket	1
14	HMB-100-14	Machine Bushing 1 x 14GA	4
15	HMB-100-10	Machine Bushing 1 x 10GA	2
16	15-495	Extension Spring	2
17	33-306	Right Cam Stop (must also order 33-307)	2
18	33-308	Right Center Tube Bracket	1
	HBS-38-16-125	Stainless Steel Bolt <sup>3</sup> / <sub>8</sub> - 16 x 1 <sup>1</sup> / <sub>4</sub>	2
	HWS-38	Stainless Steel Washer <sup>3</sup> / <sub>8</sub>	2
	HNTL-38-16	Lock Nut <sup>3</sup> / <sub>8</sub> - 16	2
19	16-927	Center Tube	1
20	33-330	Right Actuator Bracket	1
	HBS-38-16-125	Stainless Steel Bolt <sup>3</sup> / <sub>8</sub> - 16 x 1 <sup>1</sup> / <sub>4</sub>	4
	HWS-38	Stainless Steel Washer <sup>3</sup> / <sub>8</sub>	4
	HNTL-38-16	Lock Nut <sup>3</sup> / <sub>8</sub> - 16	4
21	33-329	Center Mount	1
A	HSSQS-38-16-150	Stainless Steel Set Screw <sup>3</sup> / <sub>8</sub> - 16 x 1 <sup>1</sup> / <sub>2</sub> (part of 33-329)	2
	HN-38-16	Nut <sup>3</sup> / <sub>8</sub> - 16 (part of 33-329)	2
22	33-331	Left Actuator Bracket	1
	HBS-38-16-125	Stainless Steel Bolt <sup>3</sup> / <sub>8</sub> - 16 x 1 <sup>1</sup> / <sub>4</sub>	4
	HWS-38	Stainless Steel Washer <sup>3</sup> / <sub>8</sub>	4
	HNTL-38-16	Lock Nut <sup>3</sup> / <sub>8</sub> - 16	4
23	33-309	Left Center Tube Bracket	1
	HBS-38-16-125	Stainless Steel Bolt <sup>3</sup> / <sub>8</sub> - 16 x 1 <sup>1</sup> / <sub>4</sub>	2
	HWS-38	Stainless Steel Washer <sup>3</sup> / <sub>8</sub>	2
	HNTL-38-16	Lock Nut <sup>3</sup> / <sub>8</sub> - 16	2
24	HRPS-14-150	Stainless Steel Roll Pin <sup>1</sup> / <sub>4</sub> x 1 <sup>1</sup> / <sub>2</sub>	4
25	33-302	Left Pivot Bracket	1
26	33-305	Pivot	2
	HMBS-58-14	Stainless Steel Machine Bushing <sup>5</sup> / <sub>8</sub> - 14	8
	HPS-18-100	Stainless Steel Cotter Pin <sup>1</sup> / <sub>8</sub> x 1	2
	HBS-38-16-125	Stainless Steel Bolt <sup>3</sup> / <sub>8</sub> - 16 x 1 <sup>1</sup> / <sub>4</sub>	4
	HWS-38	Stainless Steel Washer <sup>3</sup> / <sub>8</sub>	4
	HNTL-38-16	Lock Nut <sup>3</sup> / <sub>8</sub> - 16	4
27	33-295	Pivot Bracket	2
	15-494	Nylon Flange Bushing (part of 33-295)	4
	18-036	Oilite Bushing (part of 33-295)	4
B	HSSQS-38-16-150	Stainless Steel Set Screw <sup>3</sup> / <sub>8</sub> - 16 x 1 <sup>1</sup> / <sub>2</sub>	2
	HN-38-16	Nut <sup>3</sup> / <sub>8</sub> - 16	2
28	HCPS-12-225	Stainless Steel Clevis Pin <sup>1</sup> / <sub>2</sub> x 2 <sup>1</sup> / <sub>4</sub>	4
	HPS-18-100	Stainless Steel Cotter Pin <sup>1</sup> / <sub>8</sub> x 1	4

(Continued on next page)



# 15-493 STAINLESS STEEL 18' AUTO BOOM DRAWING

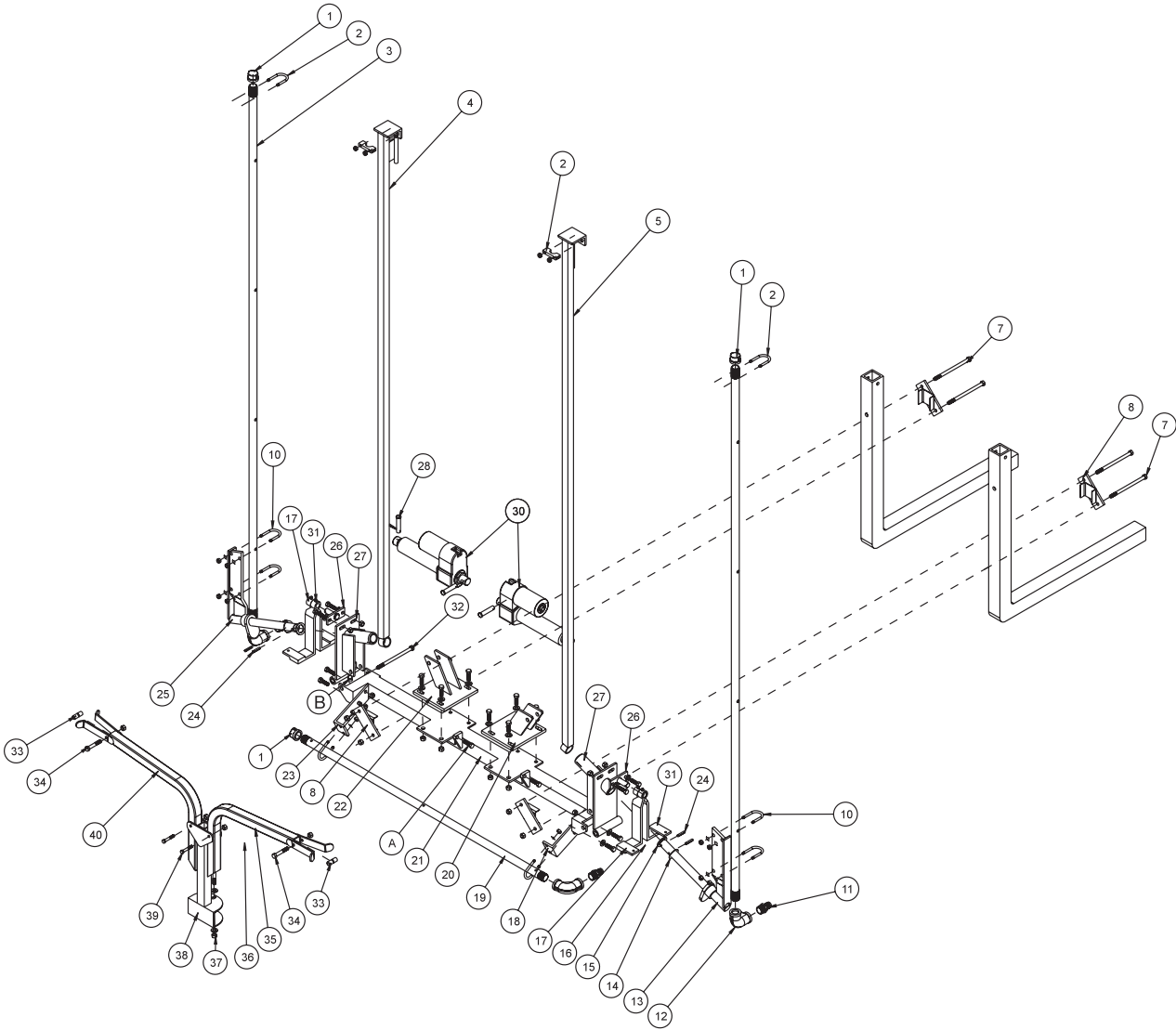

Accessories

# BOOM CARRIER DRAWING

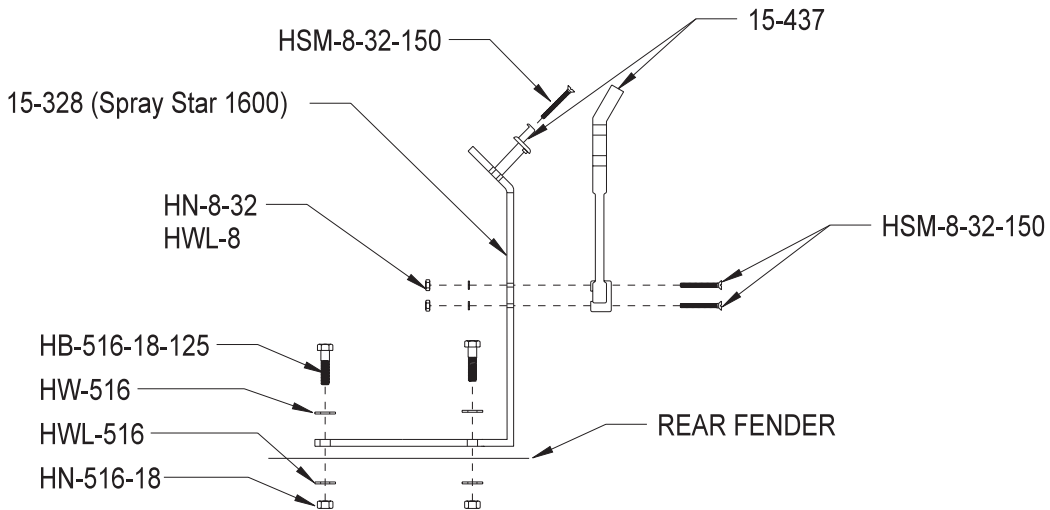

## 15-493 STAINLESS STEEL 18' AUTO BOOM PARTS LIST

REF#	PART#	DESCRIPTION	QUANTITY
30	11-158	Linear Actuator with 4" Stroke	2
31	33-307	Left Cam Stop (must also order 33-306)	2
	18-268	Oilite Bushing (part of 33-307)	2
32	HBS-12-13-550	Stainless Steel Bolt 1/2 - 13 x 5 1/2	2
	HNCL-12-13	Center Lock Nut 1/2 - 13	2
33	18-289	Bushing 3/8 ID - 1/2 OD x 5/8	4
34	HB-38-16-225	Bolt 3/8 - 16 x 2 1/4	2
	HNTL-38-16	Lock Nut 3/8 - 16	2
35	10-247	Right Boom Stabilizer	1
36	21-212	Extension Spring	1
37	HB-38-16-300	Bolt 3/8 - 16 x 3	1
	HW-38	Washer 3/8	2
	HNTL-38-16	Lock Nut 3/8 - 16	1
38	10-162	Boom Support	1
39	HB-516-18-225	Bolt 5/16 - 18 x 2 1/4	2
	HNTL-516-18	Lock Nut 5/16 - 18	2
40	10-246	Left Boom Stabilizer	1

## INSTALLATION INSTRUCTIONS

For best results use teflon tape on all fittings.

- The three boom assemblies are not on the packing list but are in carton. The long boom assemblies are the right and left booms. The labels are located on right and left pivot brackets (Ref 13 and 25). The small boom assembly is the center boom. You can NOT order these boom assemblies as one unit. Please refer to parts drawing for individual parts.
- Mount small boom assembly to rear upright support on sprayer using four boom brackets (Ref 8), four bolts, 3/8 - 16 x 5 1/2 and four lock nuts, 3/8 - 16 (Ref 7). One boom bracket should go on boom assembly and one on upright support of sprayer. Do the same for right and left side. Place boom at desired level (approximately 20" (51cm) nozzle height) and center. Tighten bolts.
- Put the actuator brackets (Ref 20 and 22) on the center mount (Ref 21) using 3/8 - 16 x 1 1/4 bolts, washers and lock nuts, with washers over the slots. Snug up the bolts so that you can adjust actuator brackets with the set screws (Ref A) on the center mount after booms have been mounted.
- Take right boom and slide pivot bracket (Ref 27) in center mount (Ref 21) and hold in place with 1/2 - 13 x 5 1/2 bolt and 1/2 - 13 center lock nut (Ref 32). Do not over tighten, boom must be able to move up and down.
- Mount actuator (Ref 30) fixed end to actuator bracket and ram end to pivot bracket using 1/2 x 2 1/4 clevis pins and 1/8 x 1 cotter pins (Ref 28). It may be necessary to lift boom slightly for proper fit. Repeat process for other boom.
- Hook hoses to respective fittings using hose clamps (18-040). The hose coming from right side of sprayer goes to straight fitting on right boom. Center hose from sprayer goes to straight fitting on center boom. The left hose from sprayer goes to straight fitting on left boom. Be sure all clamps are tight.
- Connect wire harness to actuator. Use two nylon ties (22-075) to hold wire to fixed end of actuators.
- Use boom switches to completely extend actuator and lower booms.
- Using set screws (Ref A) adjust actuator brackets so nozzles of booms are at same height with nozzles of center section. Tighten bolts holding actuator brackets to center mount and locknuts on set screws.
- Make certain set screws (B) on both sides are completely screwed in. Raise booms with boom switches all the way up, adjust set screws (A) so they contact the stop.
- To install boom carriers (15-328) and latch (15-437) see diagram. The boom holders should point upward and latch pointing outward. Use 8 - 32 x 1 1/2 machine screws, nuts and washers to install latch to boom carriers.
- To put booms into boom carriers, booms must be down. Push booms towards front of machine and lift boom slightly to clear fenders. Disconnect latch and put it over brush guard and reconnect.

# 15-577 STAINLESS STEEL 18' MANUAL BOOM DRAWING

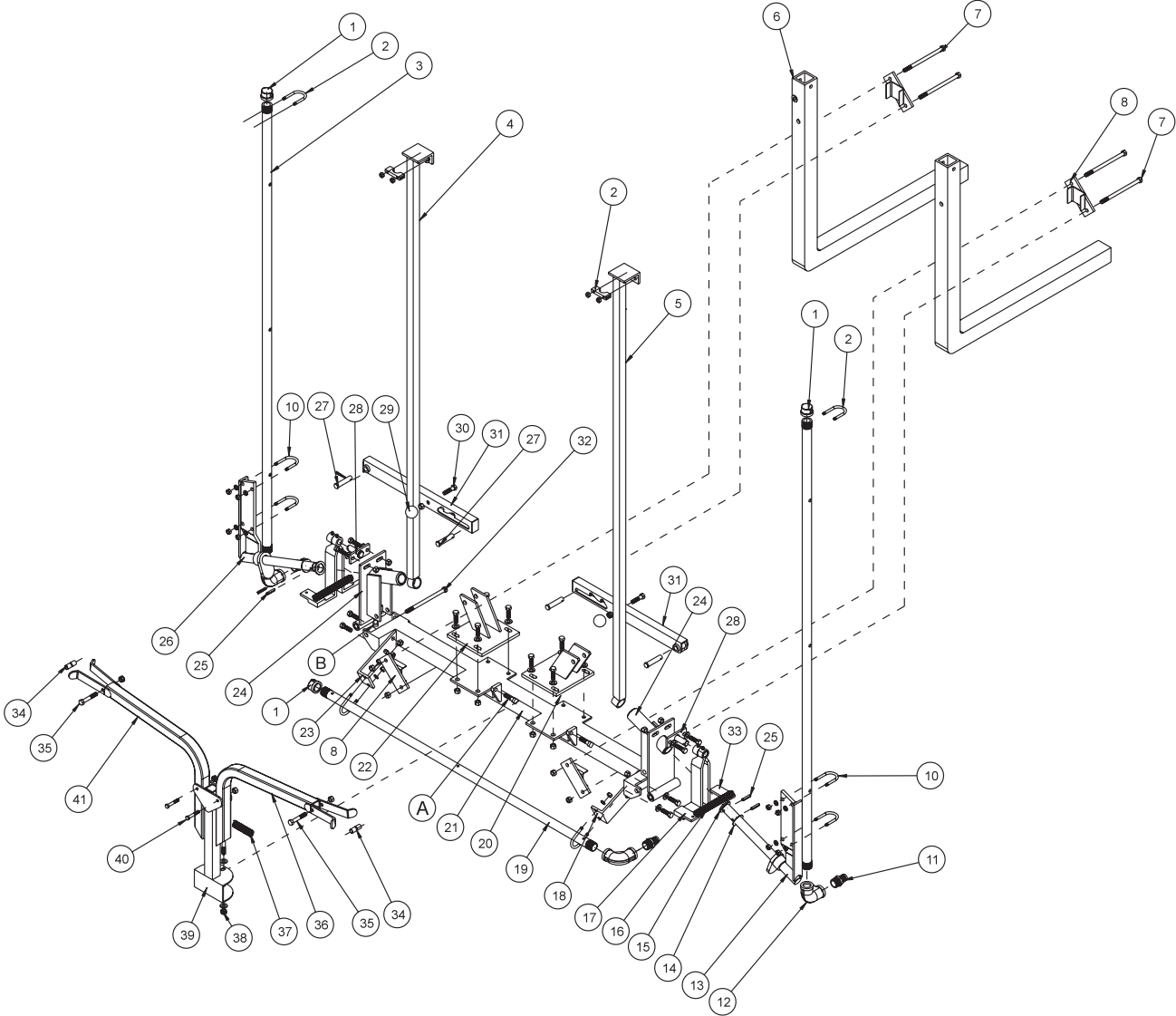

Accessories

# 15-577 STAINLESS STEEL 18' MANUAL BOOM PARTS LIST

REF#	PART#	DESCRIPTION	QUANTITY
1	16-926	Stainless Steel Cap $\frac{3}{4}$	3
2	13-498	U-Bolt Kit $1\frac{1}{8}$	2
3	16-928	Right and Left Boom Tube	2
4	33-333	Left Brush Guard	1
5	33-332	Right Brush Guard	1
6		Boom Carrier (part of the truck)	
7	HBS-38-16-550	Stainless Steel Bolt $\frac{3}{8}$ - 16 x $5\frac{1}{2}$	4
	HNTL-38-16	Lock Nut $\frac{3}{8}$ - 16	4
8	16-761	Boom Brackets	4
10	16-024	U-Bolt $\frac{5}{16}$ - 24	6
	HWLS-516	Stainless Steel Lockwasher $\frac{5}{16}$	12
	HNS-516-24	Stainless Steel Nut $\frac{5}{16}$ - 24	12
11	18-249	Barb Fitting	3
	18-040	Hose Clamp	3
12	16-925	Stainless Steel Pipe Elbow $\frac{3}{4}$ x $90^\circ$	3
13	33-301	Right Pivot Bracket	1
14	HMB-100-14	Machine Bushing 1 x 14GA	4
15	HMB-100-10	Machine Bushing 1 x 10GA	2
16	15-495	Extension Spring	2
17	33-306	Right Cam Stop (must also order 33-307)	2
	18-268	Oilite Bushing (part of 33-306)	2
18	33-308	Right, Center Tube Bracket	1
	HBS-38-16-125	Stainless Steel Bolt $\frac{3}{8}$ - 16 x $1\frac{1}{4}$	2
	HWS-38	Stainless Steel Washer $\frac{3}{8}$	2
	HNTL-38-16	Lock Nut $\frac{3}{8}$ - 16	2
19	16-927	Center Tube	1
20	33-330	Right Actuator Bracket	1
	HBS-38-16-125	Stainless Steel Bolt $\frac{3}{8}$ - 16 x $1\frac{1}{4}$	4
	HWS-38	Stainless Steel Washer $\frac{3}{8}$	4
	HNTL-38-16	Lock Nut $\frac{3}{8}$ - 16	4
21	33-329	Center Mount	1
A	HSSQS-38-16-150	Stainless Steel Set Screw $\frac{3}{8}$ - 16 x $1\frac{1}{2}$ (part of 33-329)	2
	HN-38-16	Nut $\frac{3}{8}$ - 16 (part of 33-329)	2
22	33-331	Left Actuator Bracket	1
	HBS-38-16-125	Stainless Steel Bolt $\frac{3}{8}$ - 16 x $1\frac{1}{4}$	4
	HWS-38	Stainless Steel Washer $\frac{3}{8}$	4
	HNTL-38-16	Lock Nut $\frac{3}{8}$ - 16	4
23	33-309	Left Center Tube Bracket	1
	HBS-38-16-125	Stainless Steel Bolt $\frac{3}{8}$ - 16 x $1\frac{1}{4}$	2
	HWS-38	Stainless Steel Washer $\frac{3}{8}$	2
	HNTL-38-16	Lock Nut $\frac{3}{8}$ - 16	2
24	33-295	Pivot Bracket	2
	15-494	Nylon Flange Bushing (part of 33-295)	4
	18-036	Oilite Bushing (part of 33-295)	4
B	HSSQS-38-16-150	Stainless Steel Set Screw $\frac{3}{8}$ - 16 x $1\frac{1}{2}$	2
	HN-38-16	Nut $\frac{3}{8}$ - 16	2
25	HRPS-14-150	Stainless Steel Roll Pin $\frac{1}{4}$ x $1\frac{1}{2}$	4
26	33-302	Left Pivot Bracket	1
27	HCPS-12-225	Stainless Steel Clevis Pin $\frac{1}{2}$ x $2\frac{1}{4}$	4
	HPS-18-100	Stainless Steel Cotter Pin $\frac{1}{8}$ x 1	4
28	33-305	Pivot	2
	HMB-58-14	Machine Bushing $\frac{5}{8}$ x 14GA	8
	HPS-18-100	Stainless Steel Cotter Pin $\frac{1}{8}$ x 1	2
	HBS-38-16-125	Stainless Steel Bolt $\frac{3}{8}$ - 16 x $1\frac{1}{4}$	4
	HWS-38	Stainless Steel Washer $\frac{3}{8}$	4
	HNTL-38-16	Lock Nut $\frac{3}{8}$ - 16	4

(Continued on next page)

# 15-577 STAINLESS STEEL 18' MANUAL BOOM DRAWING

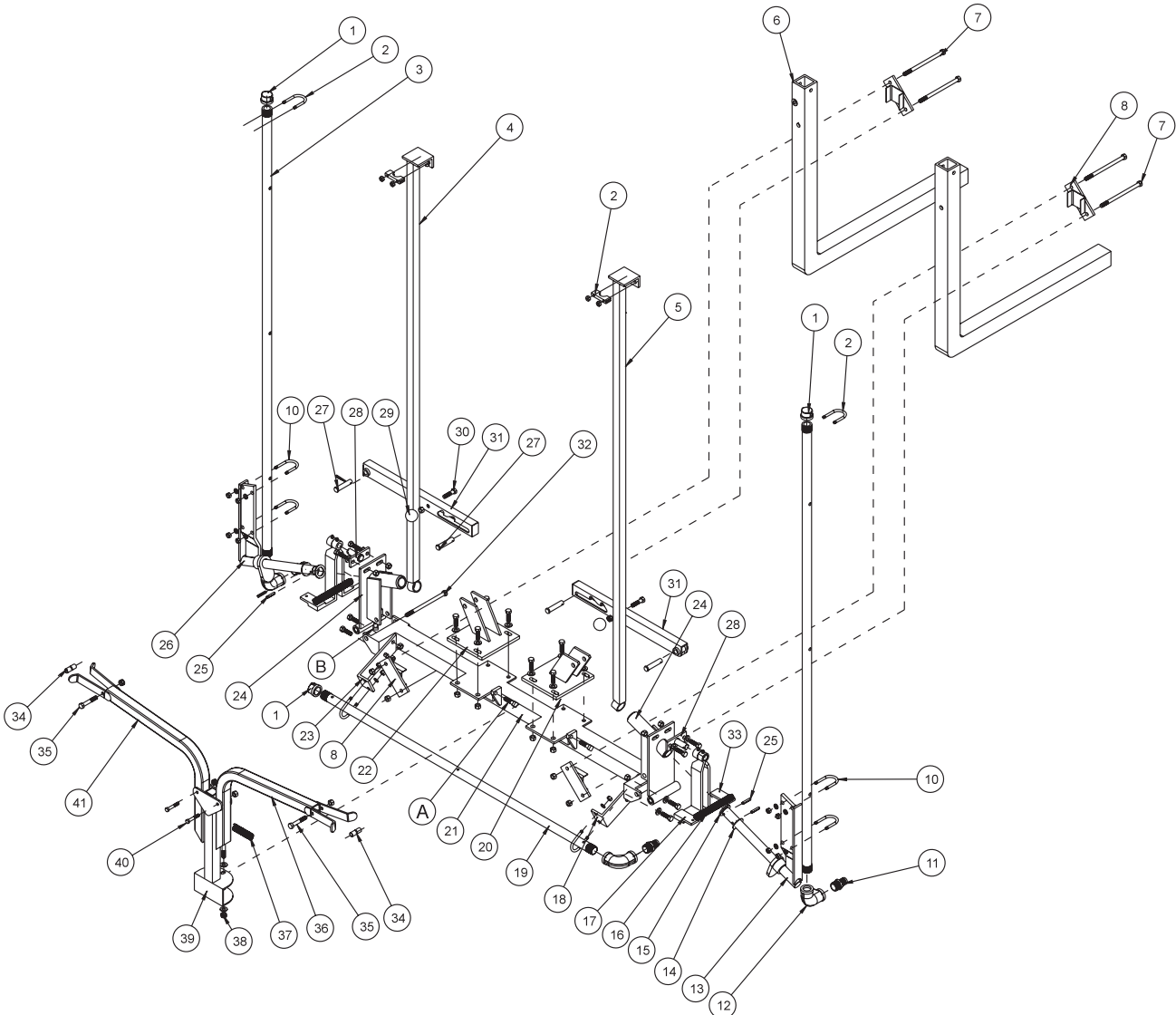

Accessories

## 15-577 STAINLESS STEEL 18' MANUAL BOOM PARTS LIST

REF#	PART#	DESCRIPTION	QUANTITY
29	15-014	Shift Knob	2
30	HB-38-16-175	Bolt $\frac{3}{8}$ - 16 x $1\frac{3}{4}$	2
	HN-38-16	Nut $\frac{3}{8}$ - 16	2
31	15-561	Boom Lift	2
32	HBS-12-13-550	Stainless Steel Bolt $\frac{1}{2}$ - 13 x $5\frac{1}{2}$	2
	HNCL-12-13	Center Lock Nut $\frac{1}{2}$ - 13	2
33	33-307	Left Cam Stop (must also order 33-306)	2
	18-268	Oilite Bushing (part of 33-307)	2
34	18-289	Bushing $\frac{3}{8}$ ID - $\frac{1}{2}$ OD x $\frac{5}{8}$	4
35	HB-38-16-225	Bolt $\frac{3}{8}$ - 16 x $2\frac{1}{4}$	2
	HNTL-38-16	Lock Nut $\frac{3}{8}$ - 16	2
36	10-247	Right Boom Stabilizer	1
37	21-212	Extension Spring	1
38	HB-38-16-300	Bolt $\frac{3}{8}$ - 16 x 3	1
	HW-38	Washer $\frac{3}{8}$	2
	HNTL-38-16	Lock Nut $\frac{3}{8}$ - 16	1
39	10-162	Boom Support	1
40	HB-516-18-225	Bolt $\frac{5}{16}$ - 18 x $2\frac{1}{4}$	2
	HNTL-516-18	Lock Nut $\frac{5}{16}$ - 18	2
41	10-246	Left Boom Stabilizer	1

## INSTALLATION INSTRUCTIONS

For best result use Teflon<sup>®</sup> tape on all fittings.

- The three boom assemblies are not on the packing list but are in the carton. The long boom assemblies are the right and left booms. The labels are located on the pivot brackets (Ref 13 and 26). The small boom assembly is the center boom. Each assembly is shipped with the nozzle bodies (16-996) attached. The remainder part of the nozzles need to be installed. You can NOT order these boom assemblies as one unit. Please refer to parts drawing for individual parts.
- Mount small boom assembly to the boom carriers on sprayer using four boom brackets (Ref 8), four bolts,  $\frac{3}{8}$  - 16 x  $5\frac{1}{2}$  and four lock nuts,  $\frac{3}{8}$  - 16 (Ref 7). One boom bracket should go on boom assembly and one on boom carrier. Do the same for right and left side. Place boom at desired level (approximately 20" (51 cm) nozzle height) and center. Tighten bolts.
- Put the actuator brackets (Ref 20 and 22) on the center mount (Ref 21) using  $\frac{3}{8}$  - 16 x  $1\frac{1}{4}$  bolts, washers and lock nuts, with washers over the slots. Snug up the bolts so that you can adjust actuator brackets with the set screws (Ref A) on the center mount after booms have been mounted.
- Take right boom and slide pivot bracket (Ref 24) in center mount (Ref 21) and hold in place with  $\frac{1}{2}$  - 13 x  $5\frac{1}{2}$  bolt and  $\frac{1}{2}$  - 13 center lock nut (Ref 32). Do not over tighten, boom must be able to move up and down. Repeat for left boom.
- Install boom lifts (Ref 31) using clevis pin and cotter pin (Ref 27) so the bushing end hooks to the pivot bracket (Ref 24) and the slotted end hooks to the actuator bracket (Ref 20 and 22).
- Hook hoses to respective fittings using hose clamps (18-040). The hose coming from right side of sprayer goes to straight fitting on right boom. Center hose from sprayer goes to straight fitting on center boom. The left hose from sprayer goes to straight fitting on left boom. Be sure all clamps are tight.
- Use the adjustment slots on the boom lifts to completely lift and lower booms.
- Using set screws (Ref A) adjust actuator brackets so nozzles of booms are at same height with nozzles of center section. Tighten bolts holding actuator brackets to center mount and locknuts on set screws.
- To install boom carriers (15-328) and latch (15-437) see drawing. The boom holders should point upward and latch pointing outward. Use 8 - 32 x  $1\frac{1}{2}$  machine screws, nuts and washers to install latch to boom carriers.
- To put booms into boom carriers, booms must be down. Push booms towards front of machine and lift boom slightly to clear fenders. Disconnect latch and put it over brush guard and reconnect.
- Put the viton gaskets (16-800), Raindrop tips (16-805) and quick TeeJet caps (16-921) on the nozzle bodies (16-996) on the three boom sections.
- Make certain set screws (B) on both sides are completely screwed in and locked with the lock nut.

## BOOM WIRING DIAGRAM (for 10-300/15-493 Booms)

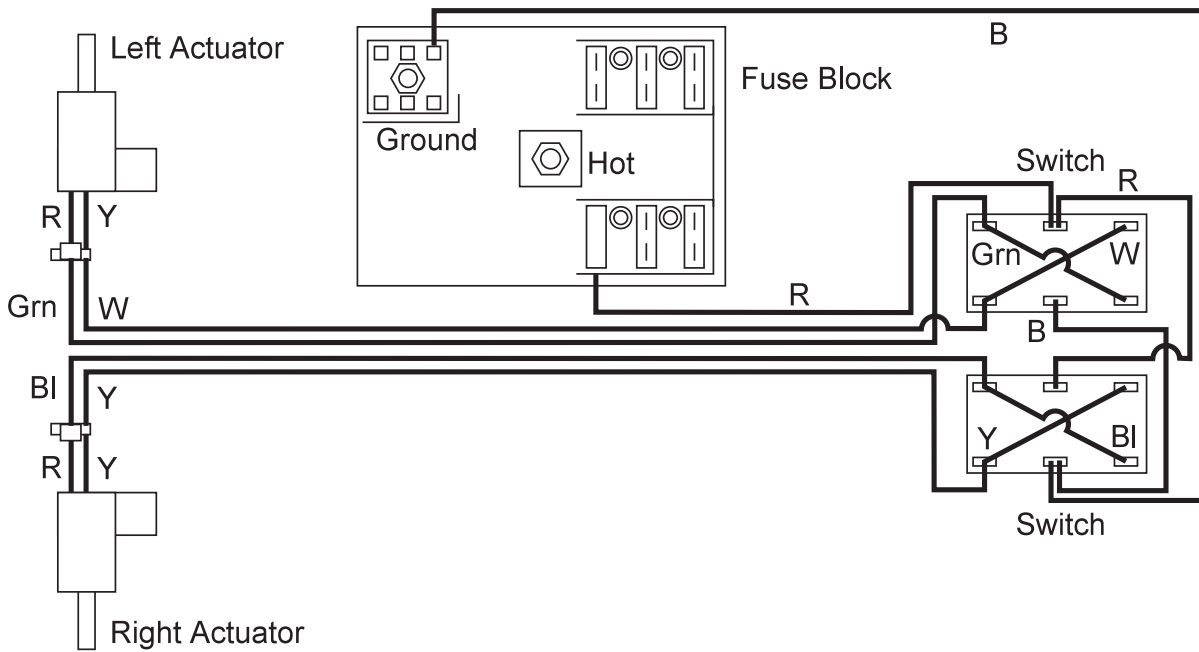

## NOZZLE ASSEMBLY DRAWING

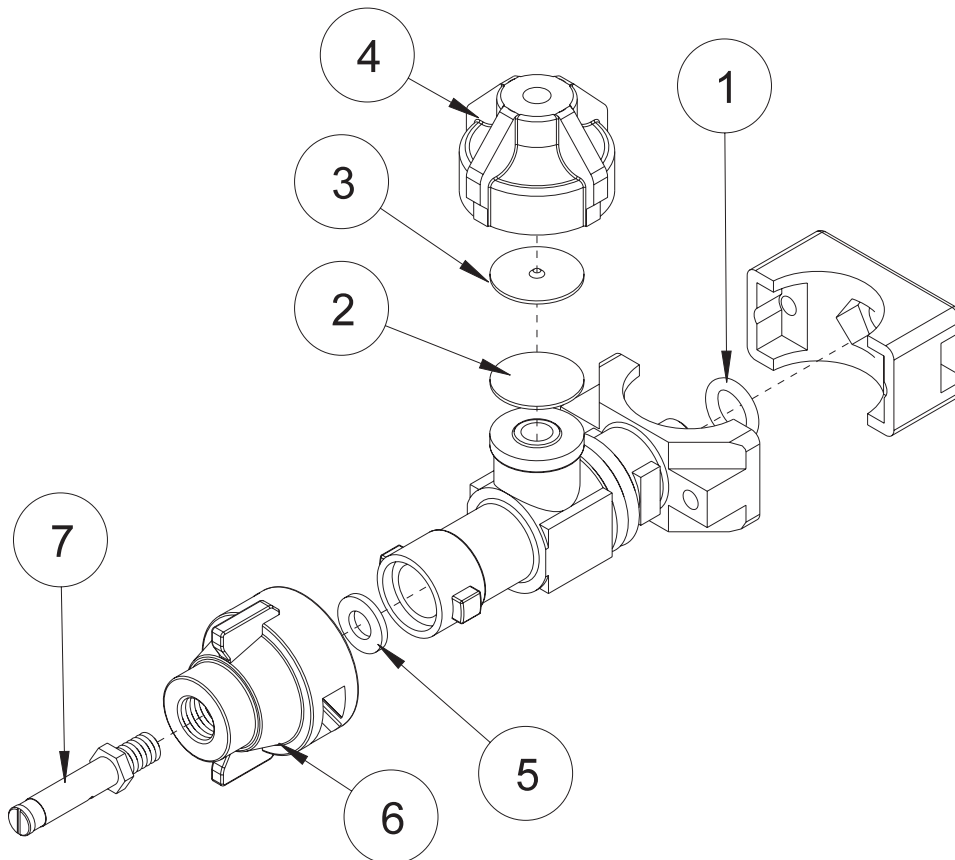



## (for 10-300/15-493 Booms) **BOOM WIRING PARTS LIST**

PART#	DESCRIPTION	QUANTITY
8853	Female Spade Connectors	2
15-472	Switch Boot	2
11-158	Linear Actuator with 4" stroke	2
16-755	Switch	2
16-810	Wiring Harness (for Spray Star 1600)	1
33-190	Wiring Harness (for Spray Star 3000)	1
22-075	Nylon Tie	10
33-273	Fuse 30 amp	1

*Use Dielectric Grease On All Electrical Connections*

## **NOZZLE ASSEMBLY PARTS LIST**

REF#	PART#	DESCRIPTION	QUANTITY
1*	16-920-03	O-Ring	1
2*	16-920-05	Diaphragm Teflon (Optional)	1
3*	16-920-06	Diaphragm EPDM Rubber (Standard)	1
4*	16-798	Chemsaver End Cap	1
5	16-800	Gasket Viton	1
6	16-921	Cap	1
7	15-588	Turbo Turf Jet Tip #8	1
*	16-996	Body	1

**NOTE:**

When the 16-920-05 Teflon Diaphragm is used, it is placed in the assembly in front of the 16-920-06 EPDM Rubber Diaphragm. Nozzles are located 20" (51 cm) apart on the right, left, and center tubes. There are predrilled holes in all tubes. The Nozzle should be at a 45° angle to the ground for proper application.

**NOTE:**

**For all 18' Booms:** The eleven 16-996 bodies are installed on the boom sections. The eleven 16-800 viton gasket, 15-588 Turbo Turf Jet Tip #8 and 16-921 cap are in the small parts bag.

**NOTE:**

**For all 15' Booms:** The nine 16-996 bodies are installed on the boom sections. The nine 16-800 viton gasket, 15-588 Turbo Turf Jet Tip #8 and 16-921 cap are in the small parts bag.

# 14-100 BOOM DRAWING

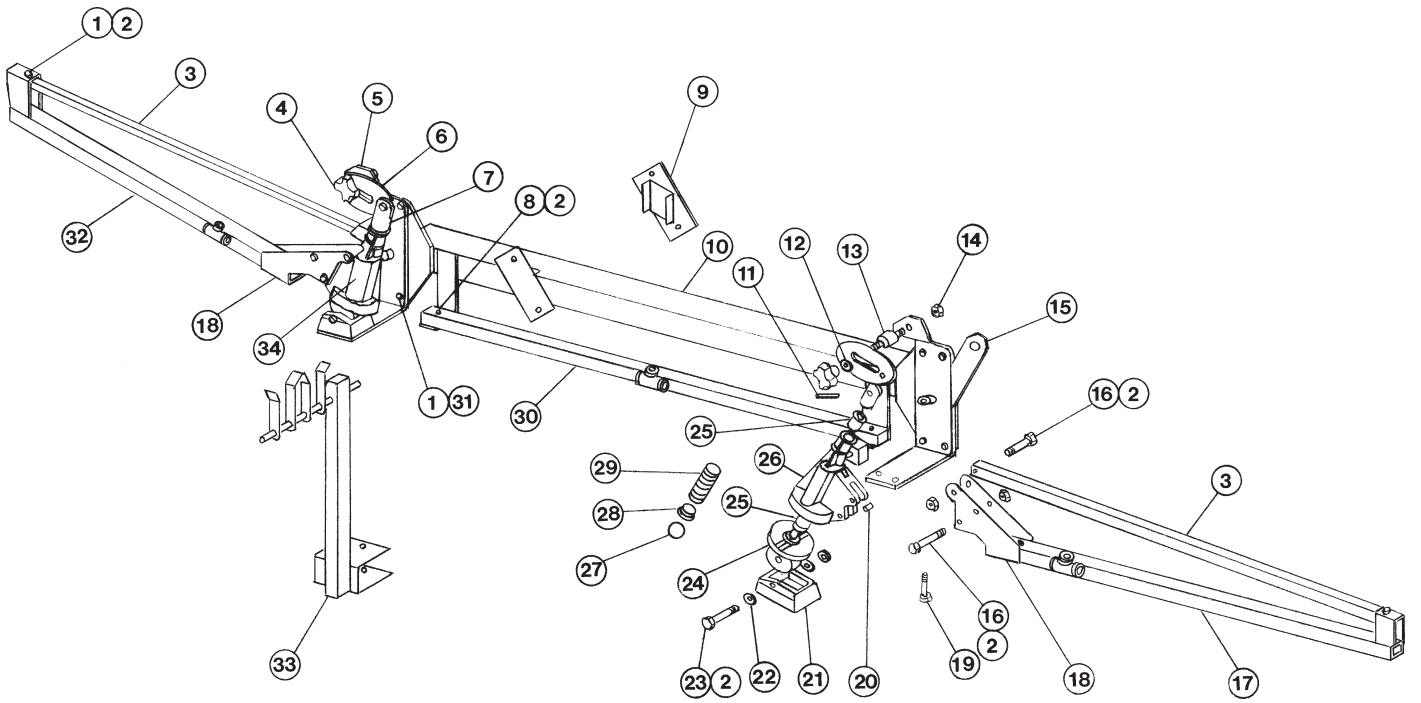

Accessories

## 14-100 BOOM PARTS LIST

REF#	PART#	DESCRIPTION	QUANTITY
1	HBM-8-25	Bolt M8 x 25	10
2	HNM-8	Nut M8	18
3	16-770	Arm Tie Bar	2
4	16-775	Knob	2
5	16-790	Left Hinge Bracket	1
	10-025	Flange Bushing <sup>3</sup> / <sub>4</sub>	1
6	16-774	Plate	2
7	16-782	Yoke	2
8	HBM-8-45	Bolt M8 x 45	2
9	16-761	Boom Bracket	4
	HB-38-16-550	Bolt <sup>3</sup> / <sub>8</sub> - 16 x 5 <sup>1</sup> / <sub>2</sub>	4
	HWL-38	Lockwasher <sup>3</sup> / <sub>8</sub>	4
	HN-38-16	Nut <sup>3</sup> / <sub>8</sub> - 16	4
10	16-791	Boom Frame	1
11	16-784	Pin D10 x 35	2
12	HW-12	Flat Washer, <sup>1</sup> / <sub>2</sub>	4
13	16-773	Stud M12	2
14	HNTLM-1 2	Top Lock Nut M12	2
15	16-789	Right Hinge Bracket	1
	10-025	Flange Bushing, <sup>3</sup> / <sub>4</sub>	1
16	HBM-8-50	Bolt M8 x 50	12
17	16-793	Right Side Boom	1
18	16-788	Boom Arm Yoke	2
19	HBM-10-25	Bolt M10 x 25	4
20	16-787	Spacer	2
21	16-786	Hinge Base	4
22	HW-516	Flat Washer <sup>5</sup> / <sub>16</sub>	8
23	HBM-8-60	Bolt M8 x 60	2
24	16-785	Aluminum Ball Bearing	2
25	16-781	Boom Washer	4
26	16-783	Yoke Support	2
27	16-780	1" Hinge Ball D 25.4	2
28	16-779	Spring/Ball Retainer	2
29	16-778	Spring	2
30	16-792	Center Boom	1
31	HNTLM-8	Top Lock Nut M8	8
32	16-794	Left Side Boom	1
33	16-212	Boom Arm Support Bracket	1
	HB-38-16-350	Bolt <sup>3</sup> / <sub>8</sub> - 16 x 3 <sup>1</sup> / <sub>2</sub>	1
	HNCL-38-16	Center Lock Nut <sup>3</sup> / <sub>8</sub> - 16	1
34	16-914	Hinge Assembly	2

14-100 6 Meter Boom includes the 16-807 Nozzle Kit (Raindrop Tips)

14-101 6 Meter Boom includes the 16-806 Nozzle Kit (TeeJet Tips)

# 14-100 PLUMBING & 709-422 NOZZLE KIT DRAWING (TURBO TURFJET TIPS)

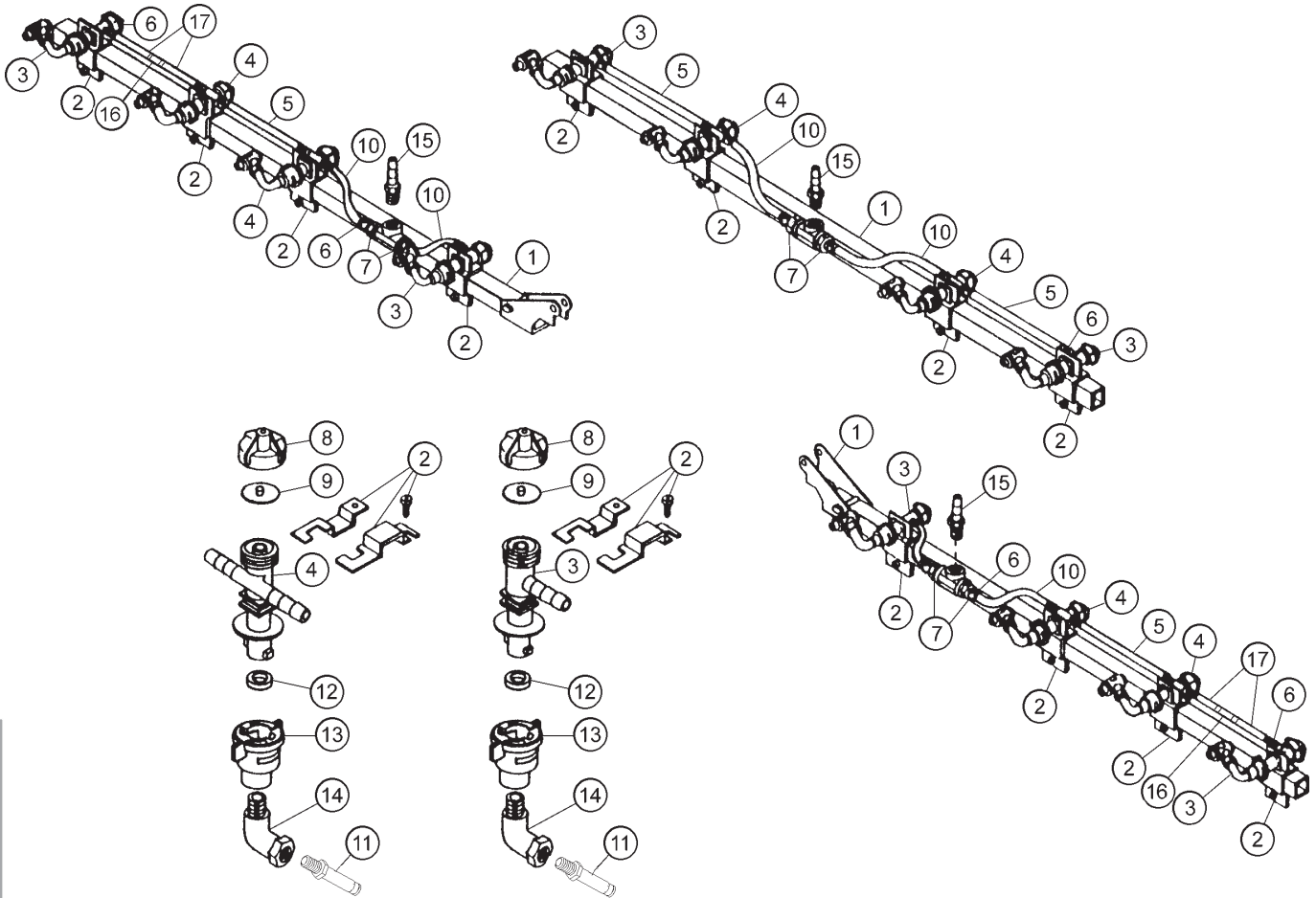

Accessories

- |         |                                  |   |
|---------|----------------------------------|---|
| 8887-92 | Orange Hose (Right & Left Booms) | 2 |
| 8887-14 | Orange Hose (Center Boom)        | 1 |
| 18-040  | Hose Clamps                      | 6 |

## 14-100 PLUMBING & 16-807 NOZZLE KIT PARTS LIST (TURBO TURFJET TIPS)

REF#	PART#	DESCRIPTION	QUANTITY
1	14-100	Boom	1
2	16-795	Square clamp 1	12
3	16-796	Diaphragm Check Valve Single (complete with 8 & 9)	6
4	16-797	Diaphragm Check Valve Double (complete with 8 & 9)	6
5	8888-19	Orange PVC Hose 1/2"	4
6	18-224	Hose Clamp 1/2"	28
7	16-137	Fitting 1/2 MPT x 1/2 HB	6
8	16-798	End Cap	12
9	16-920-06	Diaphragm	12
10	8888-8	Orange PVC Hose 1/2"	6
11*	15-558	Raindrop Tip 1/4" RA8 (all sizes available)	12
12*	16-800	Gasket	12
13*	16-921	Quick TeeJet Cap 1/4" FPT	12
14*	16-199	45° Street Elbow 1/4" PT	12
15	18-133	Fitting 1/2 MPT x 3/4 HB	3
	18-077	Hose Clamp	3
16	16-200	Ball Valve 1/4 FPT	2
	16-136	Fitting 1/4 MPT x 1/2 HB	4
17	8888-9	Orange PVC Hose 1/2"	4
*	16-807	Nozzle Kit	12 each

## PLUMBING & NOZZLE KIT INSTALLATION (RAINDROP TIPS)

All measurements are done from the fitting on center boom with booms in-line. Nozzles are exactly 20" apart.

1. Install check valves (A and B) above the square tubing and pointing to the rear.

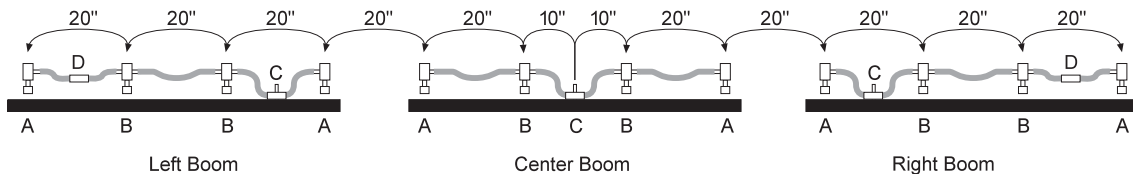

- A. Single Ended Check Valve (Ref# 3) and Clamp (Ref# 2), install with fitting toward middle of boom.
- B. Double Ended Check Valve (Ref# 4) and Clamp (Ref# 2).
- C. Fitting (Ref# 17)
- D. Ball Valve and Fitting (Ref# 15)

2. Place ball valve (D) between the outer check valves on both right and left booms. Connect the check valves together using the 1/2" hose and hose clamps.

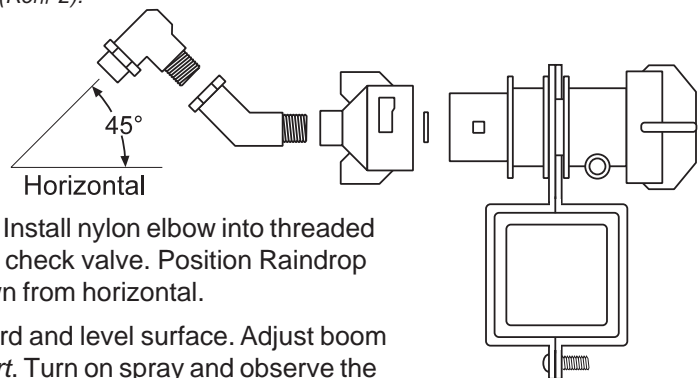

3. Install Raindrop nozzles into nylon 45° elbow. Install nylon elbow into threaded quickjet caps. Attach caps and gaskets to the check valve. Position Raindrop nozzles so they point to the rear, and 45° down from horizontal.
4. Fill the tank 1/2 full of water. Place unit on a hard and level surface. Adjust boom height according to the *Nozzle Selection Chart*. Turn on spray and observe the amount of overlapping spray between adjoining nozzles. There should be 100% overlap. The edge of the spray from one nozzle should reach to the center of the adjoining nozzle. If required, adjust boom height until the correct overlap is achieved.

Strainers are not supplied with Raindrop nozzles. Use 50 mesh slotted strainers (16-802) on nozzle tips smaller than standard.

# 14-101 PLUMBING & 709-420 NOZZLE KIT PARTS DRAWING (TEEJET TIPS)

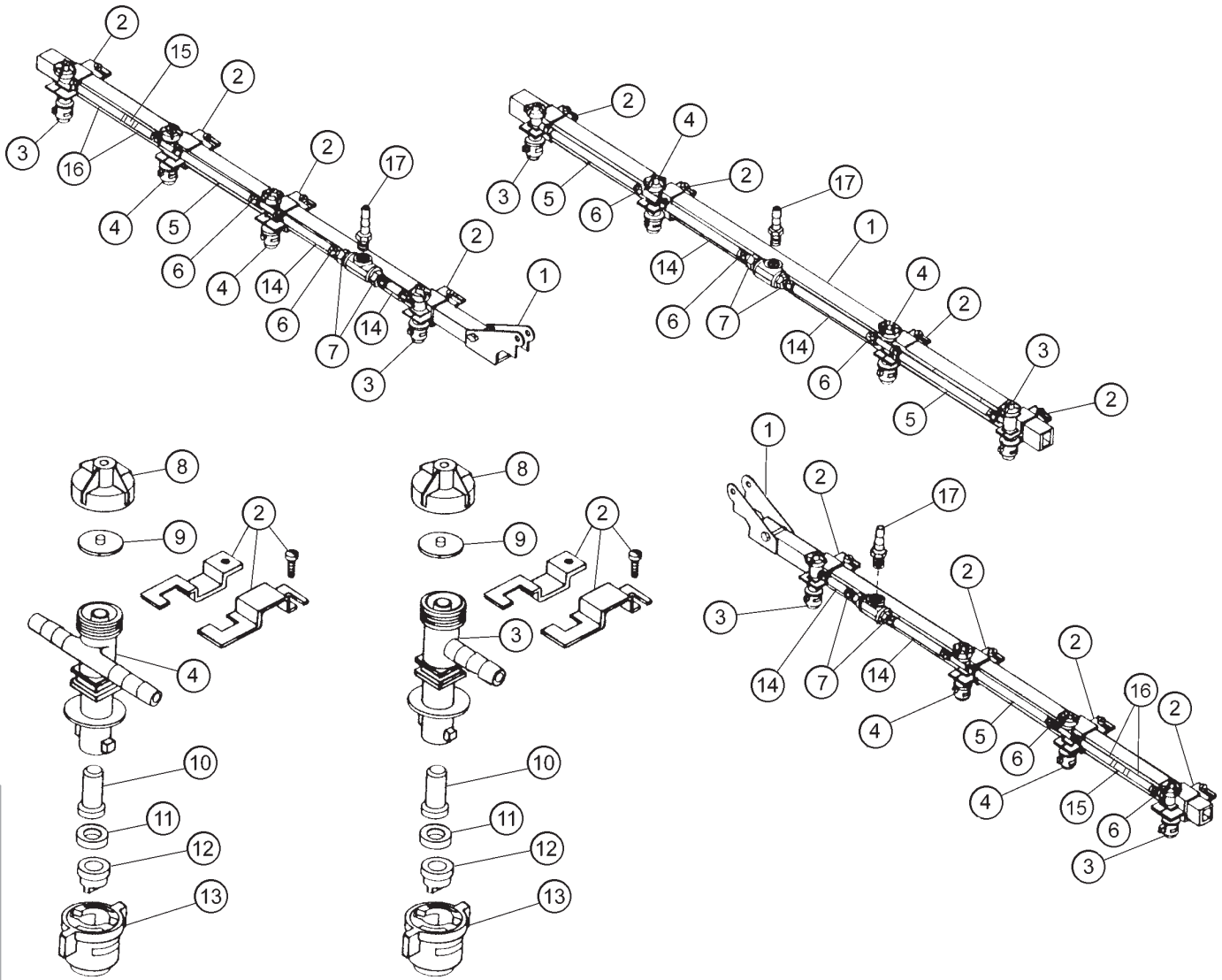

8887-92	Orange Hose (Right & Left Booms)	2
8887-14	Orange Hose (Center Boom)	1
18-040	Hose Clamps	6

Accessories

## 14-101 PLUMBING & 709-420 NOZZLE KIT PARTS LIST (TEEJET TIPS)

REF#	PART#	DESCRIPTION	QUANTITY
1	14-101	Boom	1
2	16-795	Square Clamp 1	12
3	16-796	Diaphragm Check Valve Single (includes 8 & 9)	6
4	16-797	Diaphragm Check Valve Double (includes 8 & 9)	6
5	8888-19	Orange PVC Hose 1/2"	4
6	18-224	Hose Clamp	28
7	16-137	Fitting 1/2 MPT x 1/2 HB	6
8	16-798	End Cap	12
9	16-920-06	Diaphragm	12
10*	16-802	Strainer	12
11*	16-800	Gasket	12
12*	16-803	TeeJet Tip XR8004, Standard (all sizes available)	12
13*	16-804	Quick TeeJet Cap (white)	12
14	8888-8	Orange PVC hose, 1/2"	6
15	16-200	Ball Valve 1/4 FPT	2
	16-136	Fitting 1/4 MPT x 1/2 HB	4
16	8888-9	Orange PVC Hose 1/2"	4
17	16-135	Fitting 1/2 MPT x 3/4 HB	3
	18-077	Hose Clamp	3
*	709-420	Nozzle Kit	12 each

## PLUMBING & NOZZLE KIT INSTALLATION (TEEJET TIPS)

All measurements are done from the fitting on center boom with booms in-line. Nozzles are exactly 20" apart.

1. Install check valves (A and B) behind the square tubing and pointing down.

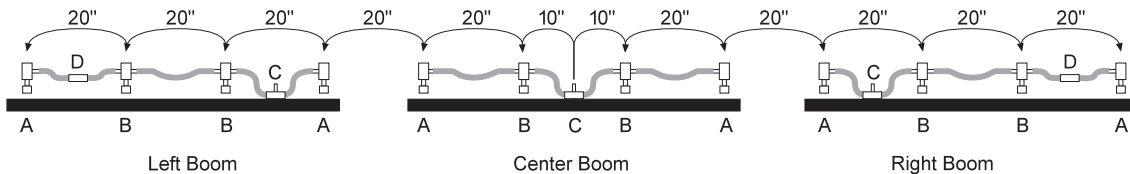

- A. Single Ended Check Valve (Ref# 3) and Clamp (Ref# 2), install with fitting toward middle of boom.
- B. Double Ended Check Valve (Ref# 4) and Clamp (Ref# 2).
- C. Fitting (Ref# 17)
- D. Ball Valve and Fitting (Ref# 15)

2. Install strainer, gasket, nozzles into cap and connect to the check valve. Strainers may be omitted if #XR8008, 8010, 8015 or 8020 nozzle tips are used.
3. Place ball valve (D) between the outer check valves on both right and left booms. Connect the check valves together using the 1/2" hose and hose clamps.
4. Fill the tank 1/2 full of water. Place unit on a hard and level surface. Adjust boom height according to the *Nozzle Selection Chart*. Turn on spray and observe the amount of overlapping spray between adjoining nozzles. There should be 30% overlap. The edge of the spray from one nozzle should reach approximate 1/3 of the way to the next nozzle. If required, adjust boom height until the correct overlap is achieved.

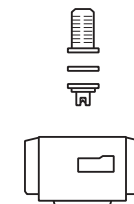
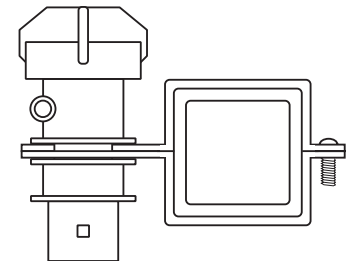

## TURBO TURFJET TIPS

This is a wide-angle (110°), hollow-cone, drift-reduction nozzle. Replaces conventional flooding nozzles in broadcast applications.

### FEATURES:

- Color-coding makes it easy to match nozzle flow rates for easy identification.
- Color-coding is available in sizes 1/4 TTJ02-VS through 1/4 TTJ15-VS.
- Uniform spray distribution.
- A large orifice opening and passages minimize clogging.
- The Turbo TurfJet nozzle's patented design element, a secondary swirl chamber in the nozzle cap, alters the swirling action of the liquid so that the fewer driftable lines are discharged from the secondary orifice.
- Spraying Pressure 25-75 PSI (1.5-5 bar).

### NOZZLE TILT

Delavan's extensive research on spray patterns has proven that a tilt of about 45° for flood Nozzles or tips will significantly improve the spray pattern uniformity.

The nozzle tilt reduces the effect of boom height variation and allows the spray nozzle to maintain a more fully developed pattern even when the nozzle outlet is below the recommended height for the best spray pattern uniformity.

### RECOMMENDED OVERLAP AND NOZZLE HEIGHT

Adjust spray height in the field to overlap a minimum of 30% of each edge of pattern. Adjust nozzle height until this is achieved. If a decision to tilt the nozzle is made, do it before measuring the width of the spray on the ground and adjusting nozzle height. See example below.

### DRIFTABLE FINES PRODUCED

(0.5 gpm at 40 psi)

Nozzle (.5 gpm Output)	Percent of Spray Volume less than 200 microns
Turbo TurfJet	< 1%



This is an extended range flat spray tip. It is excellent for Contact Pesticides and Growth Regulators and good for Systemic Pesticides.

**Contact Pesticides and Growth Regulators** - At medium pressures (20-30 psi) provides medium size droplets for good surface coverage and less drift. At higher pressures (30-60 psi) produces smaller droplets for better coverage. Wide angle 110° tips produce slightly smaller droplets than 80° tips at equal pressures.

**Systemic Pesticides** - At lower pressures (15-20 psi) produces larger spray droplets and reduces drift while still providing uniform coverage along the boom.

### **FEATURES:**

- Excellent spray distribution over a wide range of pressures (15-60 psi).
- Ideal for rigs equipped with sprayer controllers.
- Reduces drift at lower pressures, better coverage at higher pressures.
- Available in stainless steel and hardened stainless steel in 80° and 110° tip spray angles with VisiFlo color coding.

### **RECOMMENDED OVERLAP**

Adjust nozzle spray height to overlap 30% of each edge of pattern.

### **NOZZLE HEIGHT**

Suggested spray nozzle height with 20" spacing, tip spray angle of 80° should be 17-19", tip spray angle of 110° should be 12-14".

# 16-906 ELECTRIC HOSE REEL DRAWING

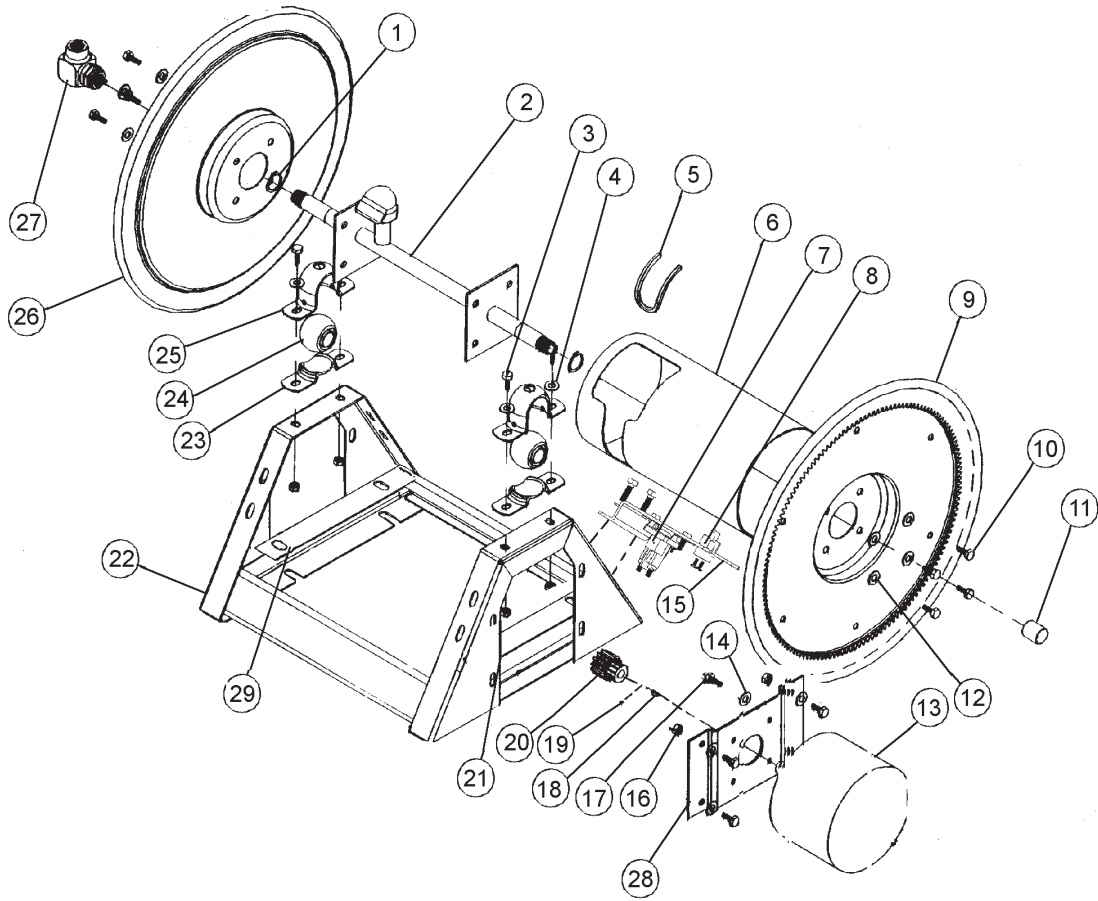

Accessories

## 16-906 ELECTRIC HOSE REEL PARTS LIST

REF#	PART#	DESCRIPTION	QUANTITY
1	16-906-25	Retaining Ring	2
2	16-906-22	Axle Assembly	1
3	HB-38-16-100	Bolt $\frac{3}{8}$ - 16 x 1	4
4	HW-38	Washer $\frac{3}{8}$	4
5	16-906-27	Trim, Drum Edge	1
6	16-906-21	Drum Center	1
7	12-015	Solenoid	1
	HB-14-20-075	Bolt $\frac{1}{4}$ - 20 x $\frac{3}{4}$	2
	HWL-14	Lockwasher $\frac{1}{4}$	2
	HN-14-20	Nut $\frac{1}{4}$ - 20	2
8	33-251	Switch	1
9	16-906-19	Disc and Gear Assembly	1
10	HB-516-18-075	Bolt $\frac{5}{16}$ - 18 x $\frac{3}{4}$	8
11	16-906-26	Pipe Cap $\frac{3}{4}$	1
12	HWL-516	Lockwasher $\frac{5}{16}$	8
13		Motor 12VDC	1
14	HW-516	Washer $\frac{5}{16}$	4
15	33-252	Switch and Solenoid Brkt	1
	HB-516-18-075	Bolt $\frac{5}{16}$ - 18 x $\frac{3}{4}$	2
	HW-516	Washer $\frac{5}{16}$	2
	HWL-516	Lockwasher $\frac{5}{16}$	2
	HN-516-18	Nut $\frac{5}{16}$ - 18	2
16	HNTL-516-18	Lock Nut $\frac{5}{16}$ - 18	4
17	HB-516-18-100	Bolt $\frac{5}{16}$ -18 x 1	4
18	16-906-17	Key	1
19		Set Screw	2
20	16-906-29	Pinion	1
21	HNTL-38-16	Lock Nut $\frac{3}{8}$ - 16	4
22	16-906-18	Frame Assembly	1
23	16-906-08	Mounting Pillow Block (Bottom)	2
24	16-906-24	Bearing	2
25	16-906-07	Mounting Pillow Block (Top)	2
26	16-906-20	Disc 17 $\frac{1}{2}$	1
27	16-906-23	Swivel Assembly $\frac{3}{4}$	1
	16-906-30	Seal Kit (For 16-906-23)	1
28	16-906-28	Bracket 12VDC	1
29	16-980	Mount Bracket	2
	HB-516-18-175	Bolt $\frac{5}{16}$ - 18 x 1 $\frac{3}{4}$	4
	HW-516	Washer $\frac{5}{16}$	4
	HNTL-516-18	Lock Nut $\frac{5}{16}$ - 18	4
	16-982	Electric Hose Reel (only)	1

# 16-129 HOSE REEL DRAWING

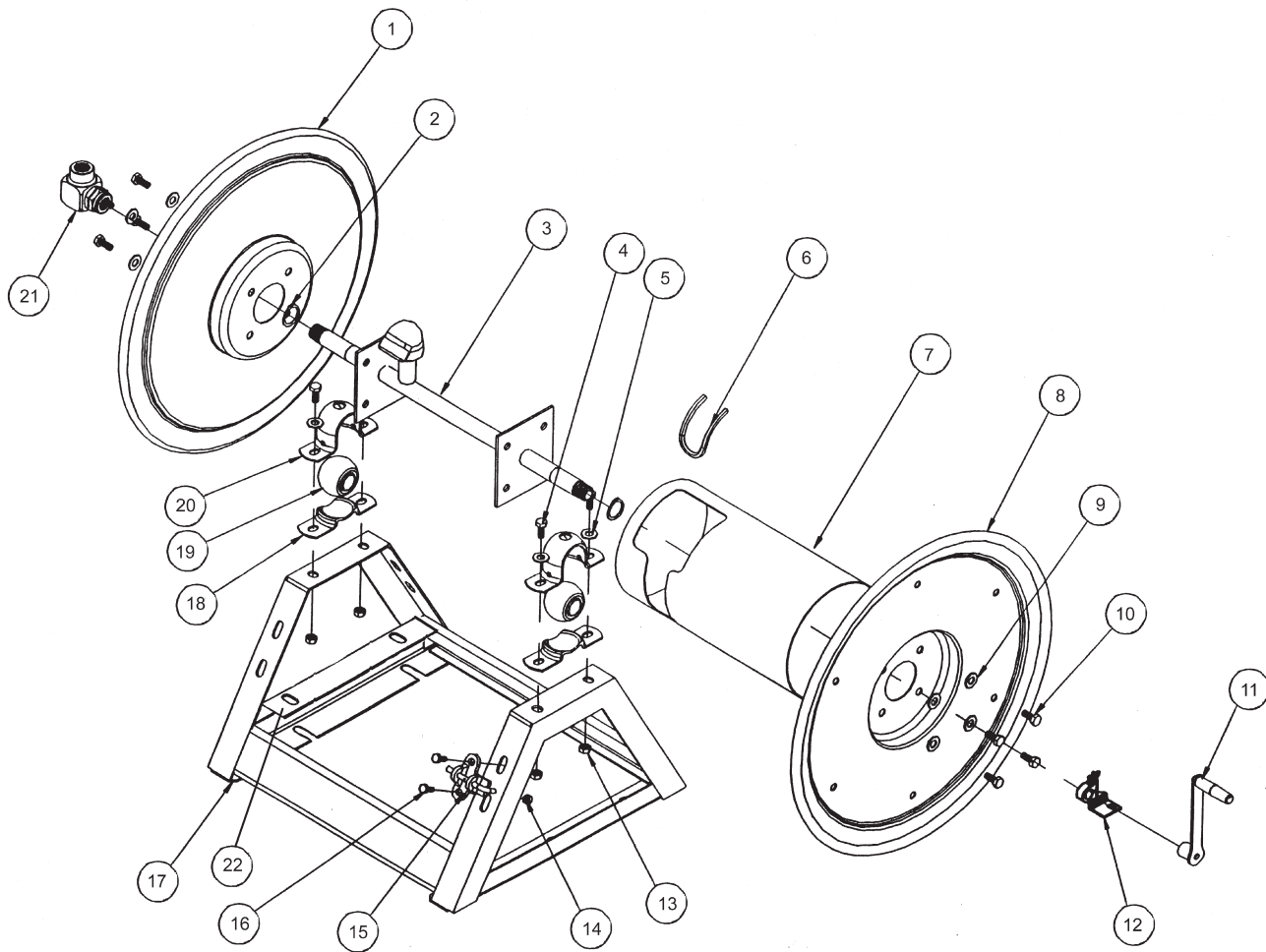

Accessories

## 16-129 HOSE REEL PARTS LIST

REF#	PART#	DESCRIPTION	QUANTITY
1	16-129-11	Disc 17 <sup>1</sup> / <sub>2</sub>	1
2	16-906-25	Retaining Ring	2
3	16-906-22	Axle Assembly <sup>3</sup> / <sub>4</sub>	1
4	HB-38-16-100	Bolt <sup>3</sup> / <sub>8</sub> - 16 x 1	4
5	HW-38	Washer <sup>3</sup> / <sub>8</sub>	4
6	16-906-27	Trim, Drum Edge	1
7	16-906-21	Drum Center	1
8	16-906-20	Disc 17 <sup>1</sup> / <sub>2</sub> , Crank Side	1
9	HWL-516	Lockwasher <sup>5</sup> / <sub>16</sub>	8
10	HB-516-18-075	Bolt <sup>5</sup> / <sub>16</sub> - 18 x <sup>3</sup> / <sub>4</sub>	8
11	16-129-09	Crank Assembly <sup>3</sup> / <sub>4</sub>	1
12	16-129-10	Brake Assembly <sup>3</sup> / <sub>4</sub>	1
13	HNTL-38-16	Lock Nut <sup>3</sup> / <sub>8</sub> - 16	4
14	HNTL-516-18	Lock Nut <sup>5</sup> / <sub>16</sub> - 18	2
15	16-129-08	Lock Pin Assembly	1
16	HB-516-18-075	Bolt <sup>5</sup> / <sub>16</sub> - 18 x <sup>3</sup> / <sub>4</sub>	2
	HW-516	Washer <sup>5</sup> / <sub>16</sub>	2
17	16-129-07	Frame Assembly	1
18	16-906-08	Mounting Pillow Block (Bottom)	2
19	16-906-24	Bearing	2
20	16-906-07	Mounting Pillow Block (Top)	2
21	16-906-23	Swivel Assembly <sup>3</sup> / <sub>4</sub>	1
	16-906-30	Seal Kit ( For 16-906-23 )	1
22	16-980	Mount Bracket	2
	HB-516-18-175	Bolt <sup>5</sup> / <sub>16</sub> - 18 x 1 <sup>3</sup> / <sub>4</sub>	4
	HW-516	Washer <sup>5</sup> / <sub>16</sub>	4
	HNTL-516-18	Lock Nut <sup>5</sup> / <sub>16</sub> - 18	4

**14-311 HOSE REEL MOUNT AND 1610 PLUMBING DRAWING**

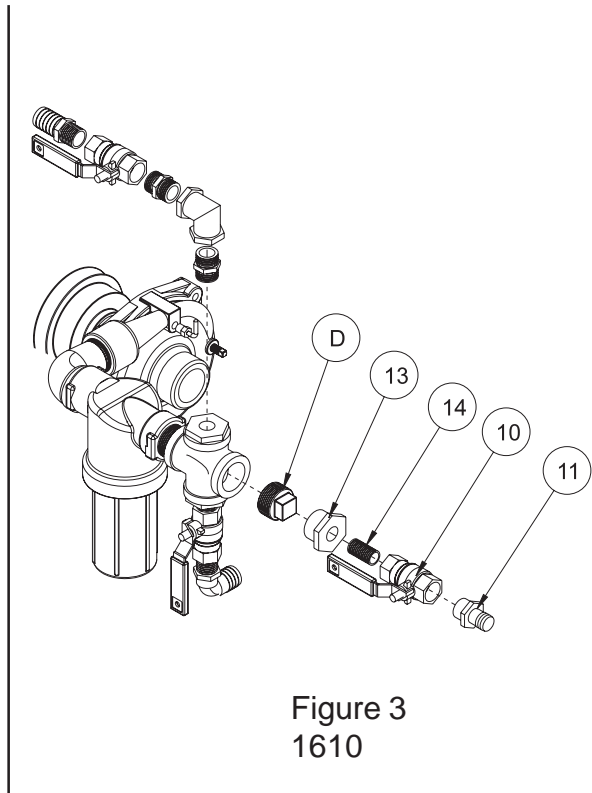
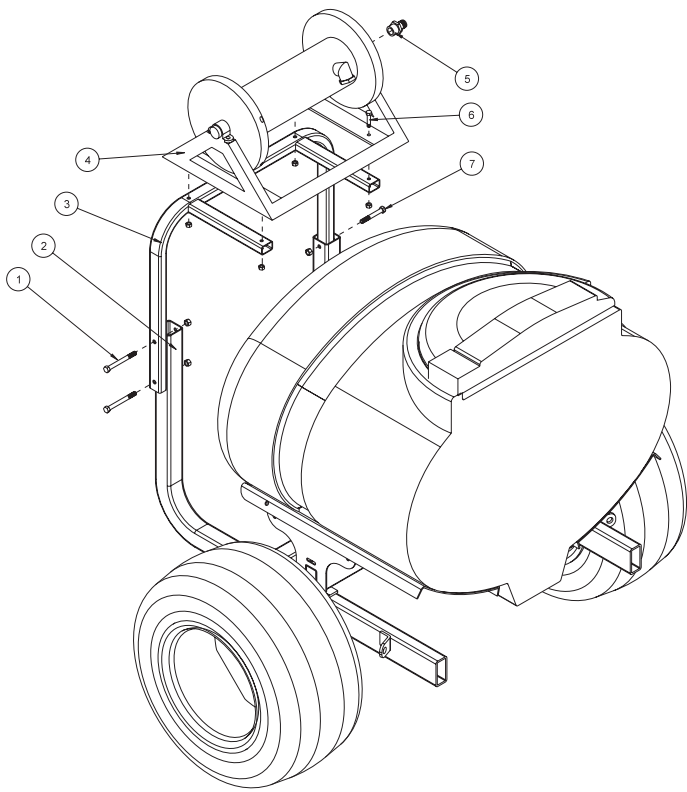

Figure 3  
1610

**HOSE REEL PLUMBING**

Accessories

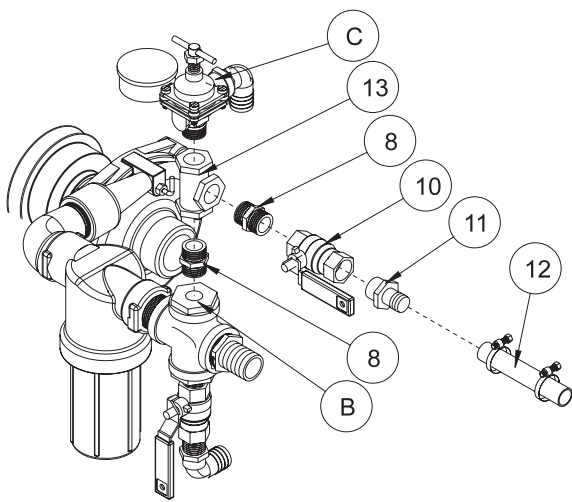

Figure 1  
1607, 1602

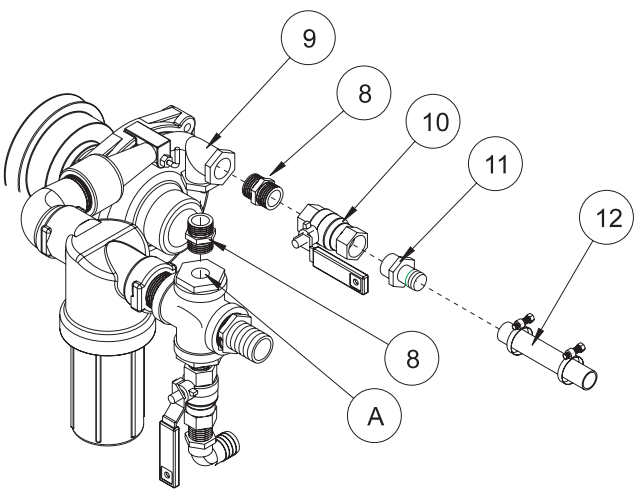

Figure 2  
1604

## 14-311 HOSE REEL PARTS LIST

REF#	PART#	DESCRIPTION	QUANTITY
1	HB-38-16-350	Bolt $\frac{3}{8}$ - 16 x $3\frac{1}{2}$	2
	HNTL-38-16	Lock Nut $\frac{3}{8}$ - 16	2
2	14-325	Boom Carrier (part of machine)	2
3	10-221	Hose Reel Mount	1
4	16-906	Electric Hose Reel	1
	16-129	Manual Hose Reel	1
5	18-249	Brass Fitting $\frac{3}{4}$ MPT x $\frac{3}{4}$ HB	1
6	HB-516-18-150	Bolt $\frac{5}{16}$ - 18 x $1\frac{1}{2}$	4
	HNTL-516-18	Lock Nut $\frac{5}{16}$ - 18	4
7	HB-38-16-250	Bolt $\frac{3}{8}$ - 16 x $2\frac{1}{2}$	2
	HNTL-38-16	Lock Nut $\frac{3}{8}$ - 16	2
8	16-158	Close Nipple $\frac{3}{4}$	2
9	16-151	Elbow F.P.T. $\frac{3}{4}$ x $\frac{3}{4}$	1
10	16-859	Ball Valve $\frac{3}{4}$ Brass	1
11	16-154	Fitting $\frac{3}{4}$ MPT x $\frac{3}{4}$ HB	1
12	8887-90	Orange PVC Hose $\frac{3}{4}$	1
	18-040	Hose Clamp	2
13	18-260	Bushing $1\frac{1}{4}$ x $\frac{3}{4}$	1
14	18-073	Pipe Nipple $\frac{3}{4}$	1

## INSTALLATION INSTRUCTIONS

1. Wear protective clothing when draining the tank and taking apart the lines.
2. Drain tank and spray system in a safe and approved method insuring that no chemical or water remain in tank as you will be taking apart lines.
3. Remove key from ignition, set park brake and block wheels.
4. Remove square rubber covers on boom carriers.
5. Place hose reel bracket inside the boom carrier tube on left side and outside on right side with arms pointing toward front of machine.
6. Lower bracket until top hole in bracket lines up with hole in upright. Bolt as shown.
7. Put hose reel on hose reel bracket with fitting on left side of machine. Use four bolts  $\frac{5}{16}$  - 18 x  $1\frac{1}{2}$  and four  $\frac{5}{16}$  - 18 lock nuts to hold in place. Tighten bolts.
8. Put 18-249 barb fitting into hose reels side.
9. Use 8887- 90 hose to connect reel to ball valve, clamp with 18-040 hose clamps.
10. Use 22-075 nylon ties to tie hose to main feed hose.
11. **For 1610P:** Remove pipe plug "D." Insert the bushing, pipe nipple, and ball valve. Place the hose barb fitting into the ball valve and connect the hose. See Figure 3.
12. **For 1602P and 1607P:** Remove hose from elbow on throttling valve. Remove throttling valve, gauge and elbow. Re-assemble as shown in Figure 1, using parts "C". Assemble throttling valve with gauge and elbow into top of tee and reconnect the hose.
135. **For 1604P:** Remove hex plug from "A" and assemble as shown in Figure 2.

(Continued on next page)

## ELECTRIC HOSE REEL WIRING DIAGRAM

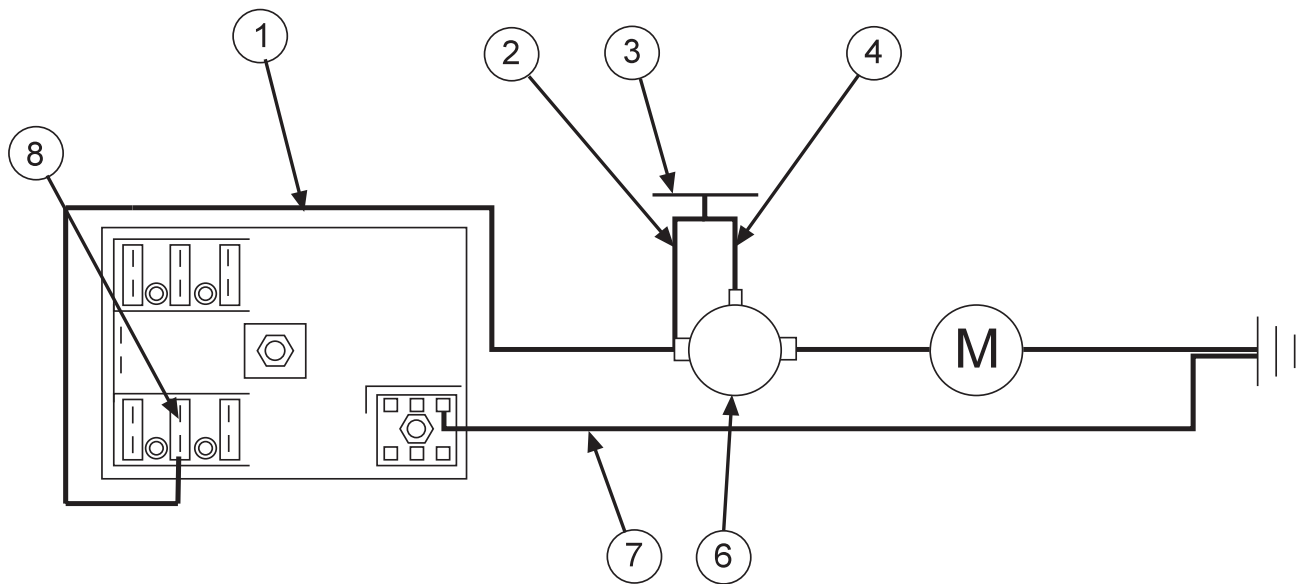

## HOSE REEL ADJUSTMENTS

### OPERATIONAL CHECK:

1. Pull hose off drum at least one full revolution. A clicking noise should be heard from locking mechanism.
2. Let the hose retract.
3. Pull the hose off until the first click is heard. Drum should lock when the hose tension is removed.
4. Continue pulling the hose, no more than one revolution, until no clicking is heard. Hose should rewind when tension is removed.

### SPRING TENSION ADJUSTMENT:

Reels are shipped with three winds of tension adequate for most application. However, if your usage requires either more or less initial tension, perform the following:

1. Make sure spring is locked.
2. Disconnect inlet hose to permit the hose to go around the drum.
3. To adjust the spring tension, add or remove the wraps of the hose from the drum, one wrap at a time, until the desired tension is obtained.

### ROLLER BRACKET ADJUSTMENT:

All hose reels are shipped with the roller bracket in the ceiling mount position. For either floor or wall mount, simply remove the guide arm that is attached to the support frame and rotate it 90°, then reinstall.

### HOSE REPLACEMENT PROCEDURE:

1. Facing swivel, turn the hose drum clockwise until all of the hose is removed from the drum and the drum is held by locking mechanism. Make sure spring is locked.
2. Remove hose clamps and disconnect hose from swivel. Remove old hose.
3. Insert new hose through roller guide, connect to swivel and reinstall hose clamps. Use spring guard over hose to protect the hose from being cut by the drum.
4. Remove check ball from old hose and install on replacement hose.
5. Carefully, keeping the tension on the hose, pull the hose to release the locking mechanism. Let the hose wind on the drum.



## ELECTRIC HOSE REEL WIRING PARTS LIST

REF#	PART#	DESCRIPTION	QUANTITY
	8843-132	Flexguard $\frac{3}{8}$ ID	1
1	8919-144	10GA Red Wire 144"	1
	8901	Slide-On Connector	1
2	16-979	Wire, Switch to Solenoid Hot Terminal	1
3	33-251	Push Button Switch	1
4	16-978	Wire, Switch to Solenoid Start Terminal	1
6	12-015	Solenoid	1
<b>SOLENOID TERMINALS</b>			
	HN -516-24	$\frac{5}{16}$ - 24 Hex Nut	2
	HN -10-32	10 - 32 Hex Nut	1
7	8931-144	10GA White Wire 144"	1
	8901	Slide-On Connector	1
8	33-273	Auto Blade Type Fuse 30Amp	1

### CONNECTION INSTRUCTIONS

Route wire harness along side of tank and over to fuse block taking care to stay clear of moving parts or hot engine components. Cut off excess wire and strip back  $\frac{3}{8}$ ". Place one 8963 heat shrink ( $\frac{1}{4}$  x  $1\frac{1}{4}$ ) on each wire before crimping 8901 slide on connectors to the red and white wires. Connect the two wires to the fuse block first the red to the (+) positive and the white to the (-) negative. Put the 33-273 auto blade type fuse (30 amp) into fuse block.



**Make certain you are connecting positive (+) to positive; negative (-) to negative while attaching power leads. If you do not observe polarity, damage will result to electrical components.**

*Use Dielectric Grease On All Electrical Connections*

# 14-283 FOAM MARKER FOR 1600P DRAWING

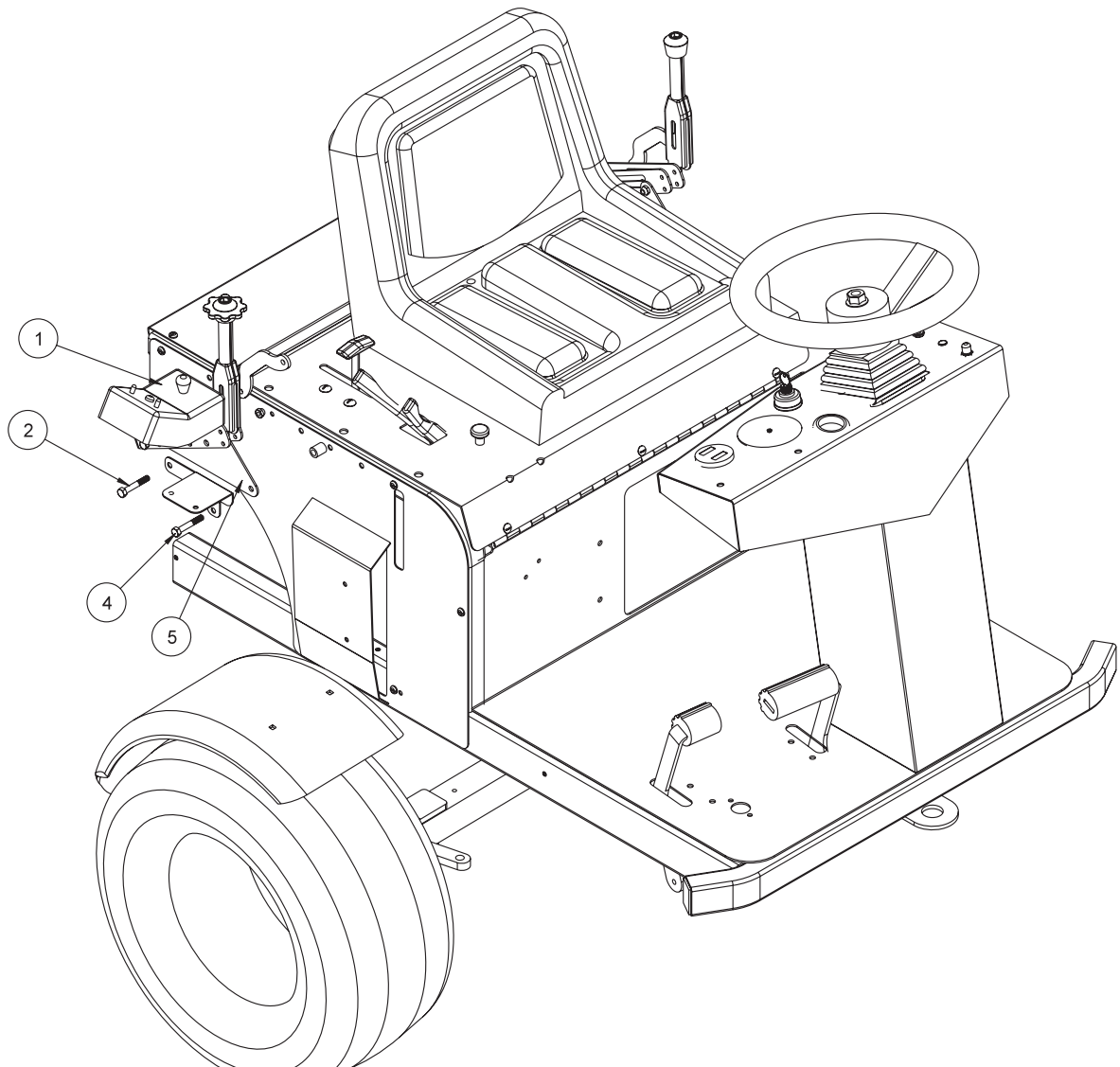

## WIRING DRAWING

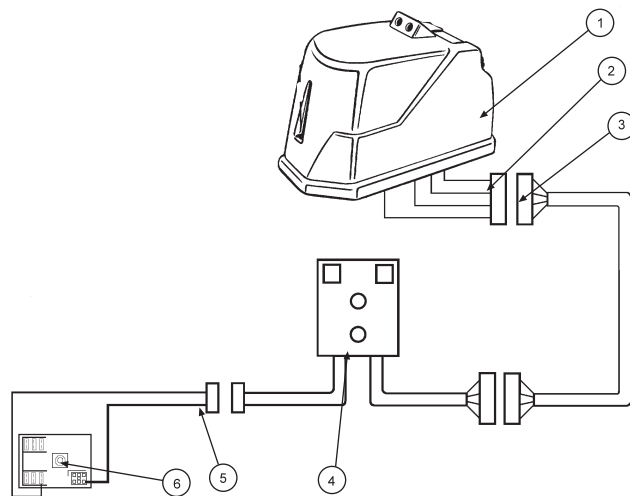

Accessories

## 14-283 FOAM MARKER FOR 1600P PARTS LIST

REF#	PART#	DESCRIPTION	QUANTITY
1*	14-284-06	Switch Box	1
	15-506-01	Fuse (F10A 250V)	1
	15-506-02	Switch	1
2	HB-516-18-175	Bolt $\frac{5}{16}$ - 18 x $1\frac{3}{4}$ (part of machine)	1
	HNTL-516-18	Lock Nut $\frac{5}{16}$ - 18 (part of machine)	1
4	HB-516-18-400	Bolt $\frac{5}{16}$ - 18 x 4 (part of machine)	1
	HNCL-516-18	Center Lock Nut $\frac{5}{16}$ - 18 (part of machine)	1
5	14-393	Park Brake Bracket (part of machine)	1
*	14-284	Foamer	1

## INSTALLATION INSTRUCTIONS

**Safety:** Before working on machine stop engine, set park brake, remove key from ignition and block wheels. Disconnect negative (-) battery terminal.

1. Remove original mounting bracket from switch box and discard.
2. To mount the switch box (Ref 1) you will have to remove the 4" bolt (Ref 4) and the  $1\frac{3}{4}$ " Bolt (Ref 2) holding the park brake bracket (Ref 5) to the side seat frame. Place the switch box bracket next to the park brake bracket and replace the 4" and  $1\frac{3}{4}$ " bolts.
3. Mount the switch box on the bracket facing towards the seat using the two wing nuts that came with the switch box.
4. Use the extension wire (10-222) to connect the compressor to the switch box.

### WIRING

Use dielectric grease on all electrical connections. Connect extension wire to the pig tail on the switch box and compressor. Connect power cable (15-509) to the switch box. Turn the switch off. Route the power wire to the fuse block (on the inside of the engine cover) out of the way of any heat or moving parts. Use nylon ties as needed. Cut the power wire with enough length to connect the fuse block. Put the slide on terminal with heat shrink onto the wire ends and connect to fuse block. Red to positive(+), black to negative(-). Insert 10 amp fuse into slot which has red wire attached to it.

## FOAM MARKER WIRING PARTS LIST

REF#	PART#	DESCRIPTION	QUANTITY
1	14-284-03	Compressor	1
2	15-504-04	Wiring Harness	1
3	10-222	Extension Wire	1
4	14-284-06	Switch Box	1
	15-506-01	Fuse (F10A 250V)	1
	15-506-02	Switch	1
5	15-509	Power Cable	1
6	33-271	Fuse Block (part of machine)	1
	33-507	Auto Blade Type Fuse 10 amp	1

**14-283 FOAM MARKER FOR 1600 DRAWING**

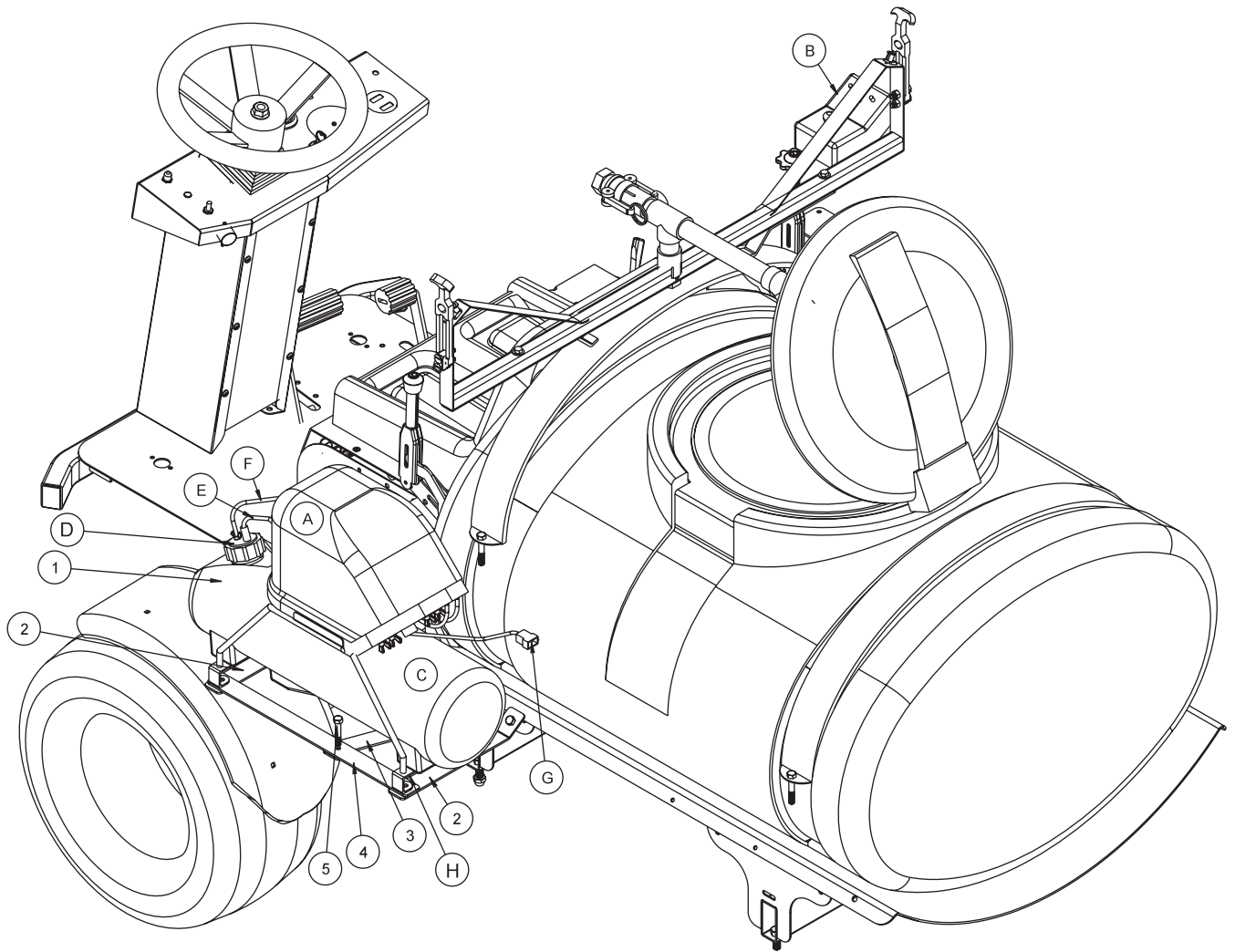

Accessories

## 14-283 FOAM MARKER FOR 1600 PARTSLIST

REF#	PART#	DESCRIPTION	QUANTITY
1	14-284	Foamer (includes all * items)	1
2	14-286	Foamer End Bracket	2
3	14-287	Foamer Center Bracket	1
4	14-288	Foamer Cross Bar	1
5	HB-516-18-100	Bolt $\frac{5}{16}$ - 18 x 1	8
	HNFL-516-18	Flange Whiz Lock Nut $\frac{5}{16}$ - 18	8
A*	14-284-03	Compressor Only	1
	14-284-01	Black Cover	1
B*	14-284-06	Switch Box	1
C*	14-284-07	Foamer Tank	1
D*	14-284-02	Cap Assembly	1
E*		Blue Tube	1
F*		Clear Tube	1
G*	10-222	Extension Wire	1
H*	14-284-04	Tank Carrier	1

## INSTALLATION INSTRUCTIONS

1. The mount two foamer end brackets (Ref 2) to the tank carrier (Ref H) in the first and third holes on the left side. Use two  $\frac{5}{16}$  - 18 x 1 bolts and flange whiz lock nuts(Ref 5).
2. Mount the foamer center bracket (Ref 3) to the slot on the tank carrier support leg.
3. Put the cross bar (Ref 4) across the ends of the end and center brackets. Bolt center brackets to cross bar using two  $\frac{5}{16}$  - 18 x 1 bolts nad flange whiz lock nuts(Ref 5).
4. Place foamer assembly (Ref 1) on the foamer end brackets and bolt in place with four  $\frac{5}{16}$  - 18 x 1 bolts nad flange whiz lock nuts(Ref 5).
5. Make sure all bolts are tightened.

### CONNECTING THE CAP ASSEMBLY

Connect the blue tube to the tank cap connector which is also connected to the large blue tube which hangs below the cap. This is the soap outlet tube. Connect the clear tube to the other connector on the tank cap. This is the air input tube. Tighten connectors hand tight, assembly tank cap onto tank.

### HOSES

Being careful not to cut the tubing, cut the oversleeve back approximately 2" (5 cm) to expose blue and clear tubing. Remove blue wing nut from top connector of foam nozzle and slide it on the blue tube with the threads facing toward end of tube. Slide blue tube all the way over the top of the small tube on foam nozzle. Slide wing nut back to the threads and hand tighten. Follow the same steps for the clear tube and tube nut.

Route the tubing along underside of main frame using tie downs as necessary.

Install opposite ends of air-liquid tubes to compressor, again cutting back the oversleeve approximately 2" (5 cm) and inserting blue and clear tubes for the left boom section into the tubing connectors on the right side of compressor as far as possible. Follow the same steps for the right boom tubing. Notice the right boom is inserted into left side of compressor. To release tubing from compressor, hold black ring around tubing, and pull tube out.

# FOAMER NOZZLE MOUNT & HOSE GUARD MOUNT DRAWING

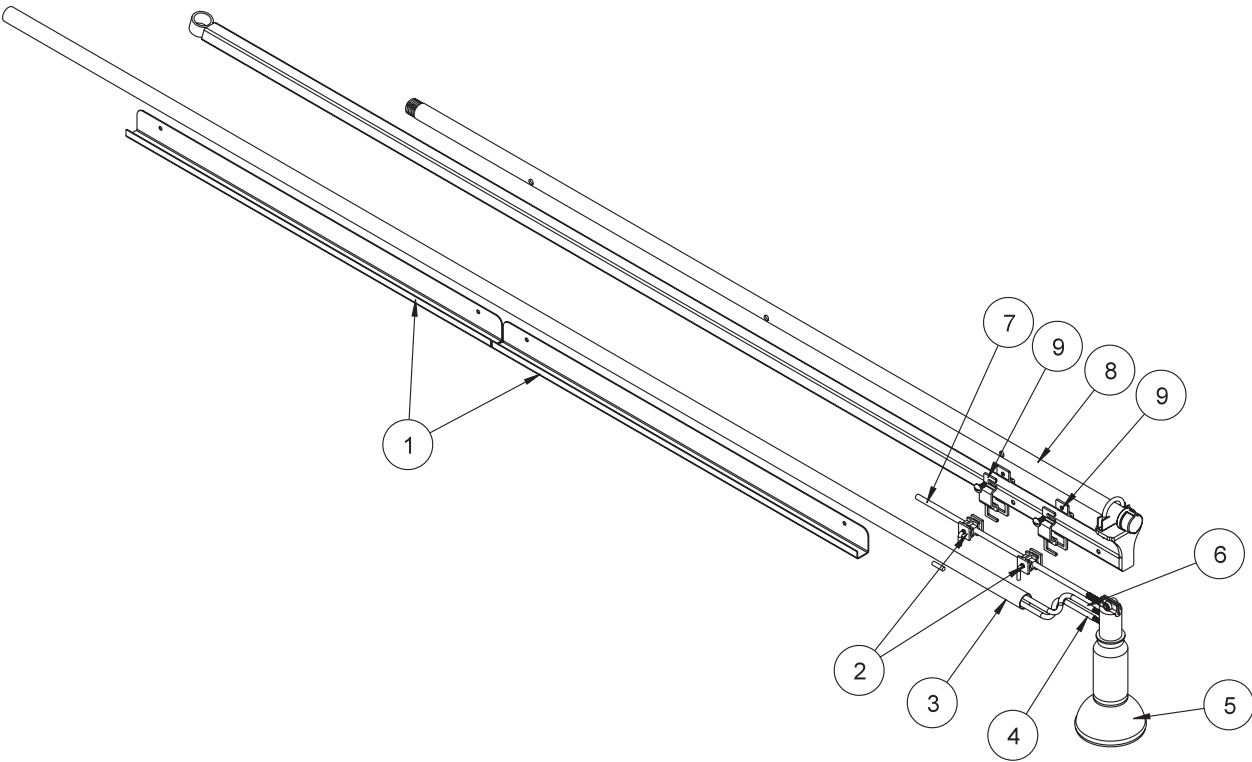

# TUBING ROUTE

Accessories

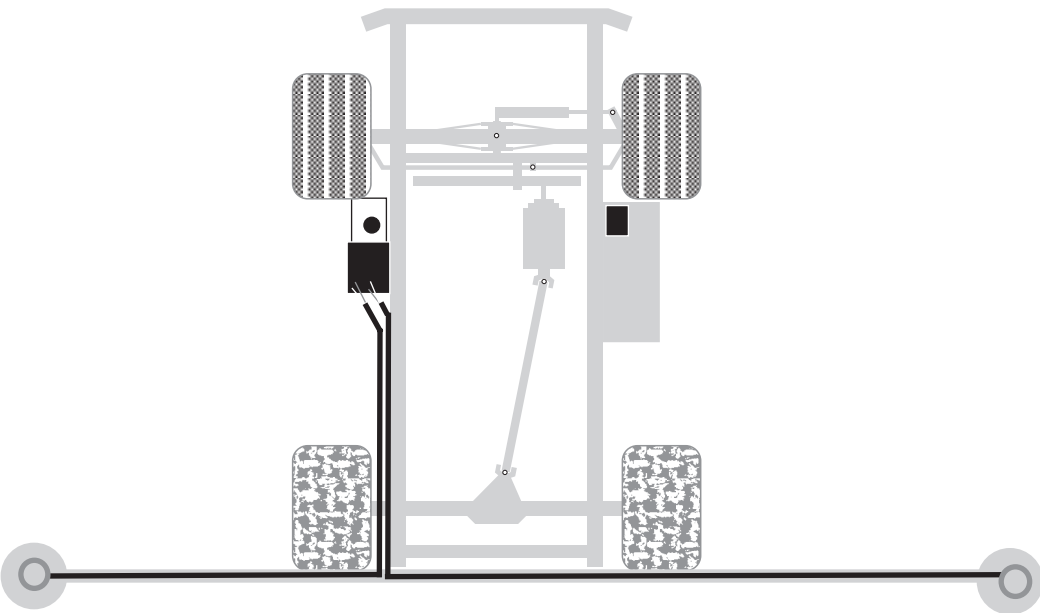

## 14-283 FOAM MARKER PARTS LIST

REF#	PART#	DESCRIPTION	QUANTITY
1	15-537	Foamer Hose Guard 31"	2
	10-256	Foamer Hose Guard 16"	2
	HSDPS-14-075	Stainless Steel Pan Head Drill Screw $\frac{1}{4} \times \frac{3}{4}$	8
2	16-987	Foam Nozzle Mounting Kit	1 per boom
3	15-507	Foamer Tubing	2
4		Clear Tubing	
5	15-511	Foam Nozzle	2
6		Blue Tubing	
7	15-510-01	Nozzle Mounting Rod	2
8		Boom	
9	16-795	Square Clamp	4

## INSTALLATION INSTRUCTIONS

- Slide hose clamp onto drop tube of foam nozzle and attach restrictor bell.
- Place splined end of Nozzle mounting rod (Ref 7) into top of foam nozzle (Ref 5). Tighten screw.
- Slide two foam nozzle mounts (Ref 2) onto the rod. Place square clamps (Ref 9) on foam nozzle mounts and mount the square clamps to the boom (Ref 8). Adjust foam nozzle mounts and clamps so nozzle assembly will clear end of boom. Tighten foam nozzle mounts and square clamps to prevent side to side movement. Do the same to the other side.
- Being careful not to cut the tubing (Ref 3), cut the oversleeve back approximately 2" (5 cm) to expose blue (Ref 6) and clear tubing (Ref 4).
- Remove blue wing nut from top connector of foam nozzle and slide it on the blue tube with the threads facing toward end of tube. Slide blue tube all the way over the top of the small tube on foam nozzle. Slide wing nut back to the threads and hand tighten. Follow the same steps for the clear tube and tube nut.
- Route the tubing along underside of main frame using tie downs as necessary.
- Install opposite ends of air-liquid tubes to compressor, again cutting back the oversleeve approximately 2" (5 cm) and inserting blue and clear tubes for the left boom section into the tubing connectors (Ref A) on the right side of compressor as far as possible.
- Follow the same steps for the right boom tubing. Notice the right boom is inserted into left side of compressor. To release tubing from compressor, hold black ring around tubing, and pull tube out.
- Hose's must be routed on bottom of the boom square tubing.
- Mark 6 inches in from inside edge of foamer nozzle mounting bracket on square boom tubing.
- Place hose guard (Ref 1) flush with top of square tubing with edge on previous mark. The channel covers hoses on the bottom of the square tubing.
- Install hose guard using 2 drill screws (you may want to drill a  $\frac{3}{16}$  pilot hole first).
- Place another hose guard against first and install in same manner.
- Repeat process for other boom side.
- Connect small plastic electrical plug under compressor to electrical extension cable.
- For *Spray Star 1600* route extension cable under engine along the mainframe cross bar, using tie downs as necessary.
- Cut cable and strip casing, allowing enough length to connect to fuse block.
- Strip and connect slide on connectors to each wire and use the heat shrink.
- Connect black negative (-) wire to the ground and connect red wire to the positive (+).
- Insert 10 amp fuse into slot which red wire was attached to.

# 14-284 FOAM MARKER RAWING



Accessories



## 14-284 FOAM MARKER PARTS LIST

REF#	PART#	DESCRIPTION	QUANTITY
1	15-507	Foamer Tubing	2
2	14-284-07	Tank	1
3	14-284-01	Black Cover	1
	14-284-03	Compressor	1
4	14-284-02	Cap Assembly	1
5	14-284-04	Tank Carrier	1
6	14-284-06	Switch Box	1
7	15-511	Foam Nozzle	1
8	15-510-01	Nozzle Mounting Rod	1
9	16-987	Foam Nozzle Mounting Kit	1

# 15-505 MOTOR SUB ASSEMBLY DRAWING

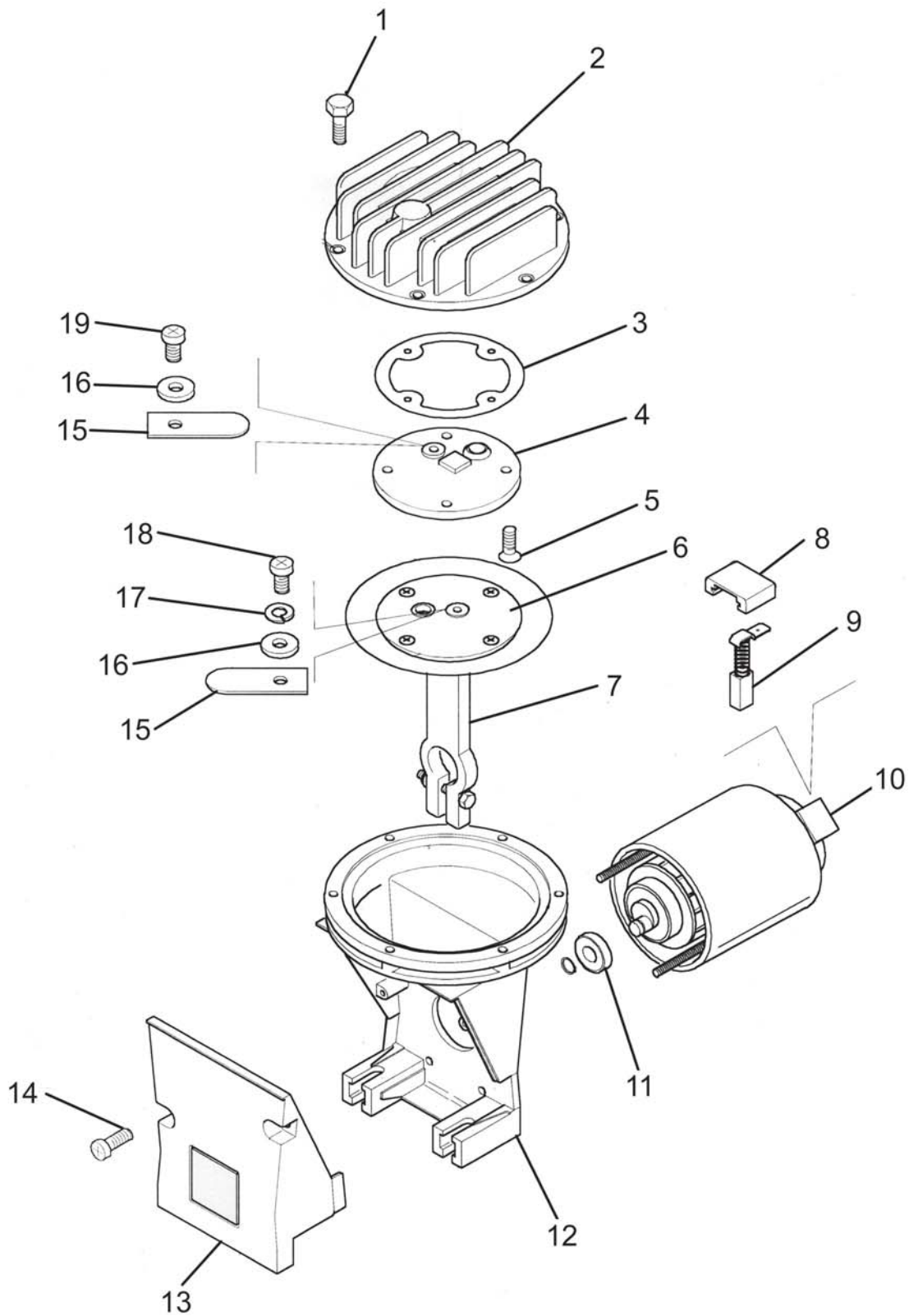

Accessories

## 15-505 MOTOR SUB ASSEMBLY PARTS LIST

REF#	PART#	DESCRIPTION	QUANTITY
1†		Bolt	6
2		Head	1
3	15-505-01	Exhaust Manifold Gasket	1
4		Exhaust Manifold	1
5†		Manifold Screw	8
6†	15-505-03	Diaphragm	1
7†		Piston	1
8		Brush Retainer	2
9	15-505-06	Brush	2
10	15-505-07	12 Volt Electric Motor	1
11	15-505-05	Stainless Steel Bearing	1
12		Block	1
13		Cover	1
14		Cover Screw	2
15*		Exhaust Reed Valve	1
16*†		Washer	2
17*†		Split Lockwasher	1
18*†		Intake Valve Screw	1
19*		Exhaust Valve Screw	1
*	15-505-02	Intake Exhaust Valve Sub Assembly	
†	15-505-04	Intake Piston Sub Assembly	

# 15-511 FOAM NOZZLE SUB ASSEMBLY DRAWING

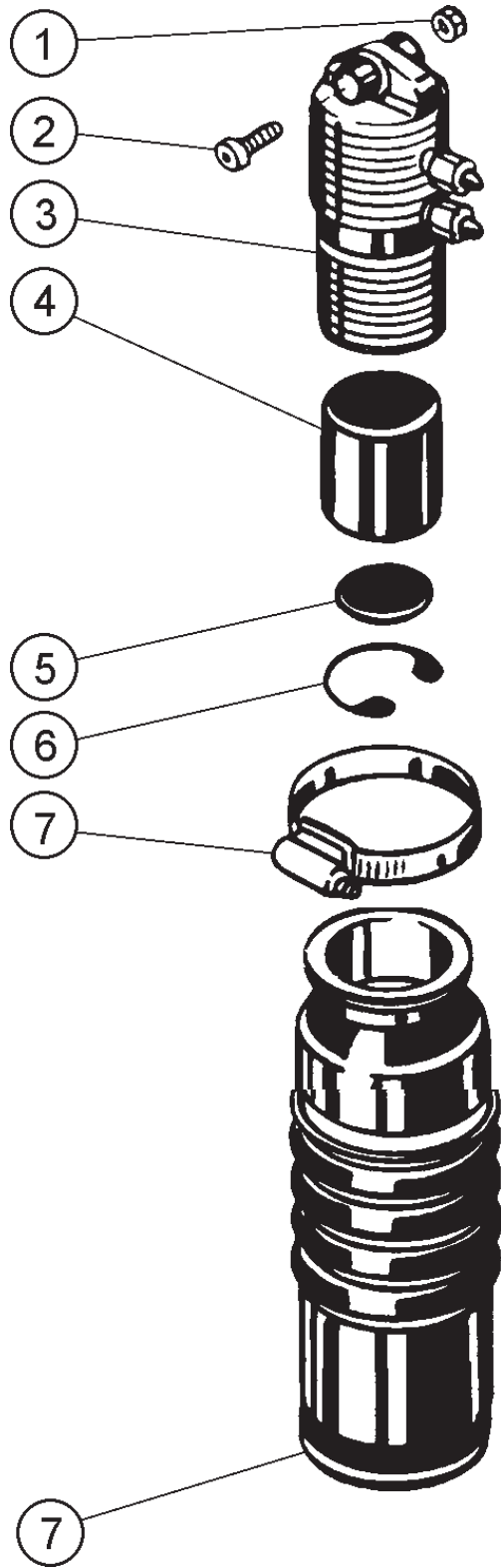

Accessories

## 15-511 FOAM NOZZLE SUB ASSEMBLY PARTS LIST

REF#	PART#	DESCRIPTION	QUANTITY
1†		Nut	1
2†		Screw	1
3†		Foam Nozzle Inlet Body	1
	15-510-01	Nozzle Mounting Rods	2
4*†	15-511-02	Foam Sponge	1
5*†		Stainless Steel Screen	1
6*†	15-511-04	Stainless Steel Snap Ring	1
7		Drop Tube	1
†	15-511-01	Foam Nozzle Inlet Sub Assembly	
*	15-511-06	Foam Kit (includes 2 each * items)	

# 15-363 FRESH WATER TANK DRAWING

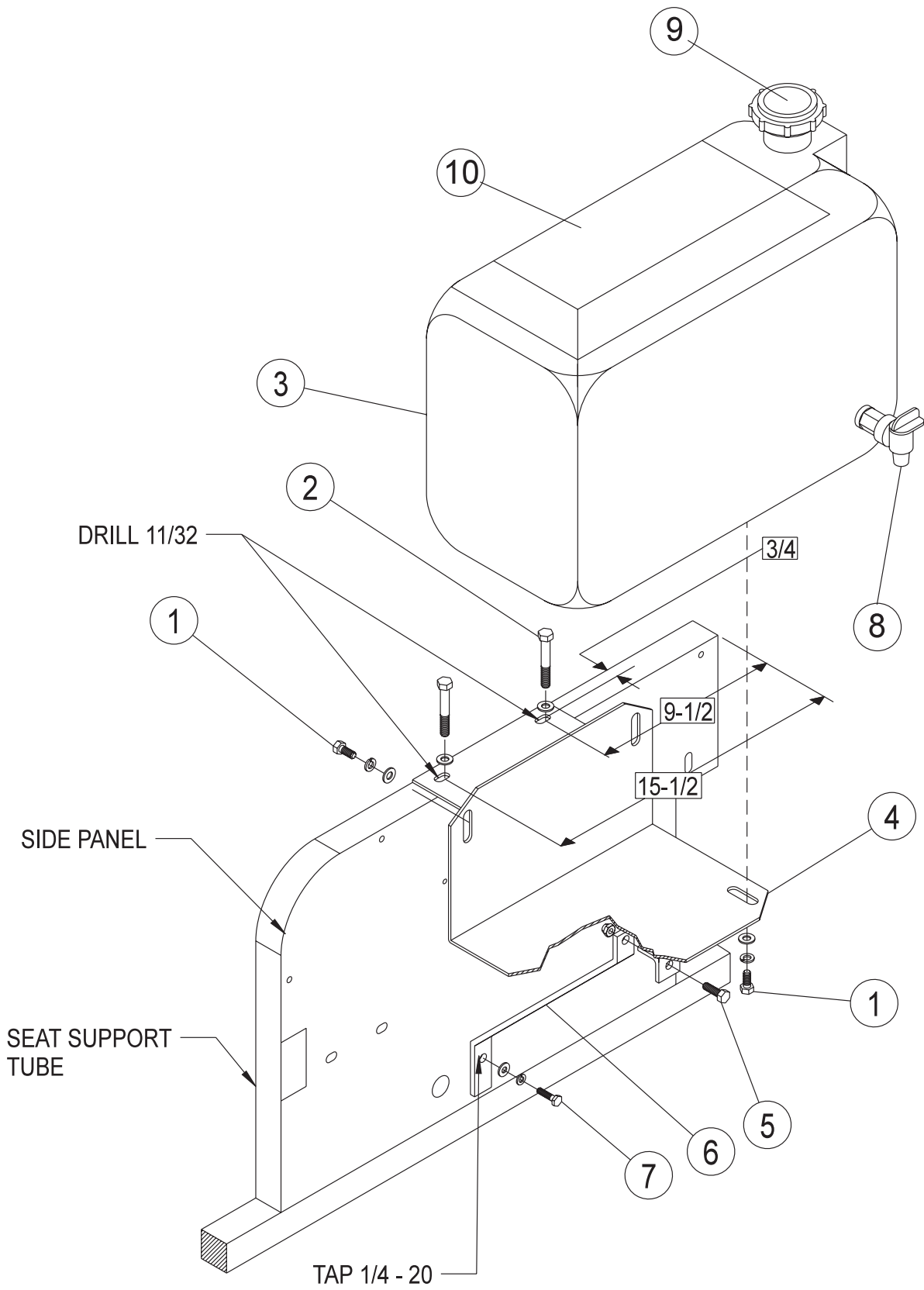

Accessories

## 15-363 FRESH WATER TANK PARTS LIST

### TO BE USED WITH 1602P, 1604P AND 1607P

REF#	PART#	DESCRIPTION	QUANTITY
1	HB-516-18-075	Bolt $\frac{5}{16}$ - 18 x $\frac{3}{4}$	4
	HWL-516	Lockwasher $\frac{5}{16}$	4
	HW-516	Washer $\frac{5}{16}$	4
2	HB-516-18-225	Bolt $\frac{5}{16}$ - 18 x $2\frac{1}{4}$	2
	HW-516	Washer $\frac{5}{16}$	2
	HNTL-516-18	Lock Nut $\frac{5}{16}$ - 18	2
3	15-488	Wash Tank (includes all * items)	1
	16-166	Hex Plug $\frac{3}{4}$	2
4	15-486	Tank Bracket	1
5	HB-14-20-100	Bolt $\frac{1}{4}$ - 20 x 1	1
	HNTL-14-20	Lock Nut $\frac{1}{4}$ - 20	1
6	15-487	Support Brace	1
7	HB-14-20-100	Bolt $\frac{1}{4}$ - 20 x 1	1
	HWL-14	Lockwasher $\frac{1}{4}$	1
	HW-14	Washer $\frac{1}{4}$	1
8*	16-960	Spigot (part of 15-488)	1
9*	15-488-01	Cap(part of 15-488)	1
10*	15-488-02	Cover Assembly (part of 15-488)	1

## INSTALLATION INSTRUCTIONS

1. Drill two  $\frac{11}{32}$  holes through both walls of left side panel and seat support tube as shown in drawing.
2. Remove drill screw from bottom edge, in middle of side panel. Run a  $\frac{1}{4}$  - 20 tap through this hole.
3. Bolt tank to tank bracket using four  $\frac{5}{16}$  - 18 x  $\frac{3}{4}$  bolts,  $\frac{5}{16}$  lockwasher and  $\frac{5}{16}$  washers.
4. Use Teflon<sup>®</sup> tape on each of the  $\frac{3}{4}$  hex plugs and install into tank.
5. Bolt tank bracket to seat support tube where you drilled the two  $\frac{11}{32}$  holes.
6. Bolt up support brace to tank bracket and side panel, as shown.

# 10-106 FRESH WATER WASH TANK DRAWING

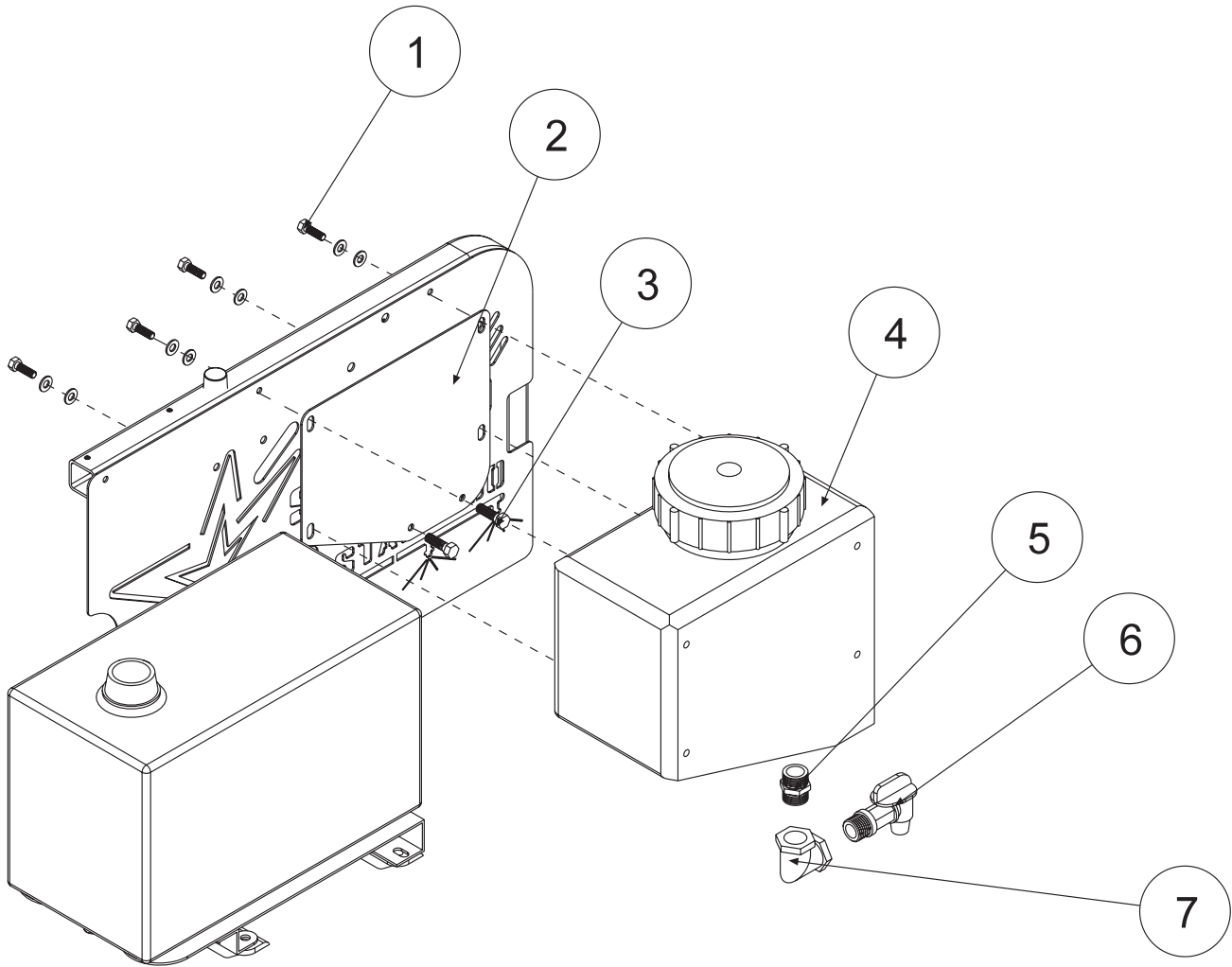

Accessories



## 10-106 FRESH WATER WASH TANK PARTS LIST

### TO BE USED WITH 1610P

REF#	PART#	DESCRIPTION	QUANTITY
1	HB-516-18-075	Bolt $\frac{5}{16}$ - 18 x $\frac{3}{4}$	4
	HWL-516	Lock Washer $\frac{5}{16}$	4
	HW-516	Washer $\frac{5}{16}$	4
2	10-216	Fresh Water Tank Bracket	1
3	HB-38-16-200	Bolt $\frac{3}{8}$ -16 x 2	2
	HNTL-38-16	Lock Nut $\frac{3}{8}$ -16	2
4	10-234	3 Gallon Rectangular Tank	1
5	16-158	Close Nipple $\frac{3}{4}$ x $\frac{3}{4}$	1
6	16-960	Spigot $\frac{3}{4}$ NPT	1
7	16-151	Elbow FPT $\frac{3}{4}$ x $\frac{3}{4}$	1

## INSTALLATION INSTRUCTIONS

1. Fresh Water Wash Tank mounts on the right side of the machine.
2. Insert the close nipple into the bottom of the tank. Then place the elbow on the close nipple so it is pointing away from the machine. Place the spigot into the elbow. For best results use plumbers tape on all fittings.
3. Place the mount bracket onto the right side panel using the two  $\frac{3}{8}$  bolts and lock nuts.
4. Line holes on the tank with holes on the mount bracket and use the  $\frac{5}{16}$  bolts to fasten tank to mount bracket.
5. Rinse tank with clear water and check for leaks around fittings.

**This tank is for fresh clear water ONLY. Do not put chemicals in this tank.**

# 14-305 OPERATOR'S PROTECTIVE ENCLOSURE DRAWING

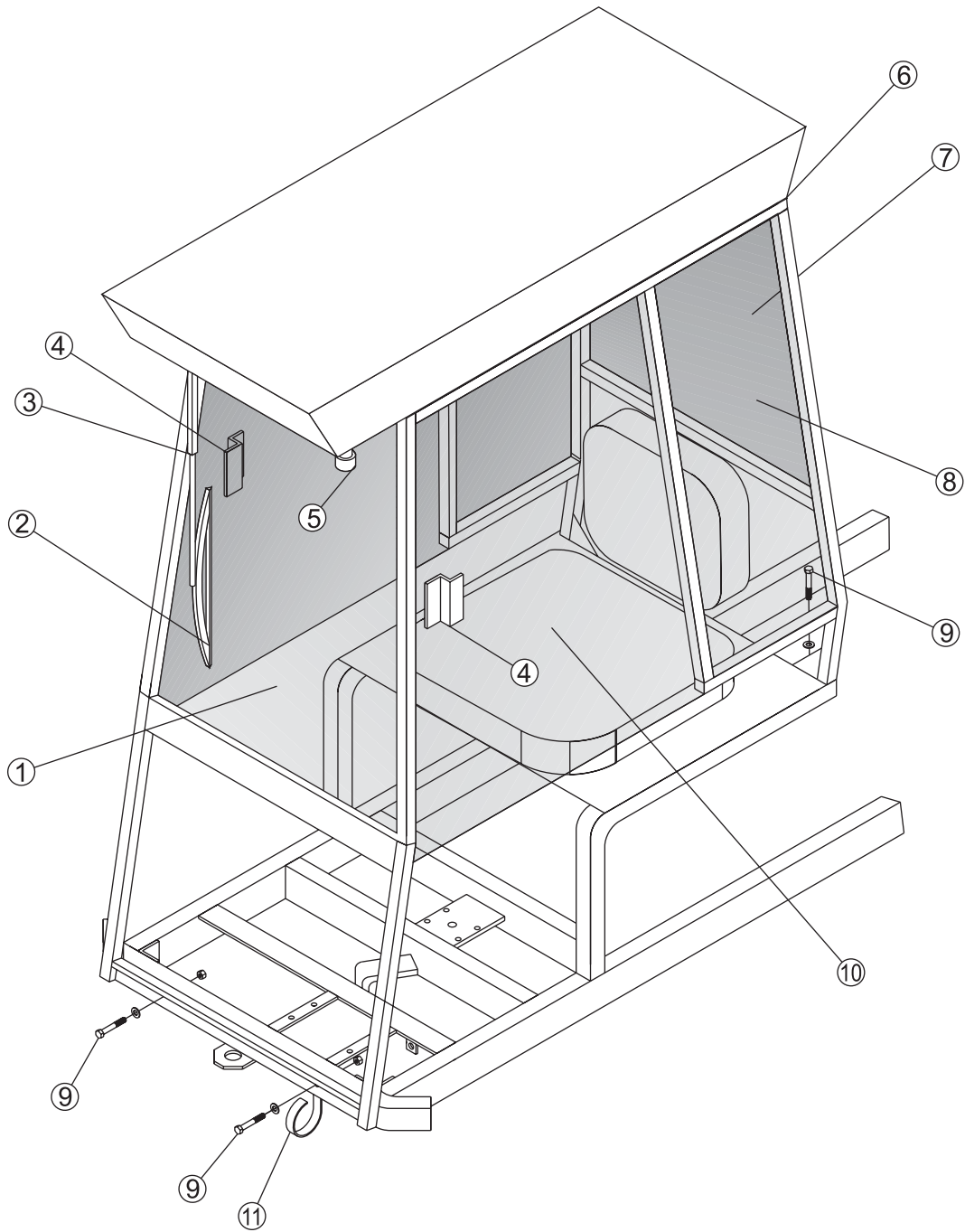

Accessories

## 14-305 OPERATOR'S PROTECTIVE ENCLOSURE PARTS LIST

REF#	PART#	DESCRIPTION	QUANTITY	
1	15-429-17	Windshield	1	
	15-429-23	Clamp	1	
2	15-429-03	Wiper Blade	1	
3	15-429-01	Wiper Motor	1	
	15-429-02	Wiper Arm	1	
4	15-429-20	Door Handle	4	
5	15-429-07	Black Plastic Knob	2	
6	15-429-24	Roof	1	
	15-429-25	Fan Panel	1	
	15-429-04	Louver	3	
	15-429-05	3-Speed Rotary Switch	1	
	15-429-06	Blower Knob	1	
	15-429-08	Inside Top 1/4" Black Poly	1	
	15-429-13	Grommet Snap Bushing	4	
	15-429-14	Filter Retainer Assembly	2	
	15-429-15	Blower	1	
	7	15-429-19	Rear Window	1
		15-429-23	Clamp	1
8	15-429-18	Rear Side Window	2	
	15-429-22	Top Rear Side Retainer	2	
9	HB-38-16-250	Bolt 3/8 - 16 x 2 1/2	4	
	HW-38	Washer 3/8	4	
	HNTL-38-16	Lock Nut 3/8-16	4	
10	15-429-16	Door	2	
	15-429-09	Self Adhesive Velcro Hook on Frame	1	
	15-429-10	Self Adhesive Velcro Loop on Door	1	
	15-429-21	Door Hinge	2	
11	HLC-A58	Loom Clamp	1	
	8857	Ring Terminal 5/16	1	
	16-909	Filter Element Complete	1	
	15-429-11	Bubble Trim Seal (19 1/4' on Edges of All Windows)	1	
	15-429-12	Channel Window Single (14' Inside of Window Channels)	1	
	33-262-05	Clip on Rubber Trim (25' on Window Sides)	1	

**FOR MACHINES SERIAL NUMBER 562 AND UP**

**Locate the end of the wire harness with the inline fuse and ring terminals. Remove fuse holder and ring terminals. Replace with the two(2) female spade connectors. Insert fuse into fuse panel and connect the lead wire from the accessories. Red to positive (+) and black too negative (-)**

**SPECIFICATIONS**

Windshield	<b>Gray Safety Glass</b>
	<b>Large Rear Window Made of Lexan</b>
Windshield Wiper	<b>12 Volt Single Speed</b>
Filter	<b>Front Intake Fresh Air Induction With Replaceable Charcoal Filter</b>
Blower	<b>3 Speed Blower, Dual Wheel 235 CFM, 12 Volt Directional Air Flow Control</b>
Doors	<b>2 Large Easy Access Doors Made Of 1/4" Lexan</b>
Frame	<b>Tubular Steel Satin Black Finish Foam Rubber Head Liner In Line Fuse Protected</b>
Overall Height	<b>78" On Machine</b>

# 14-305 OPERATOR'S PROTECTIVE ENCLOSURE DRAWING

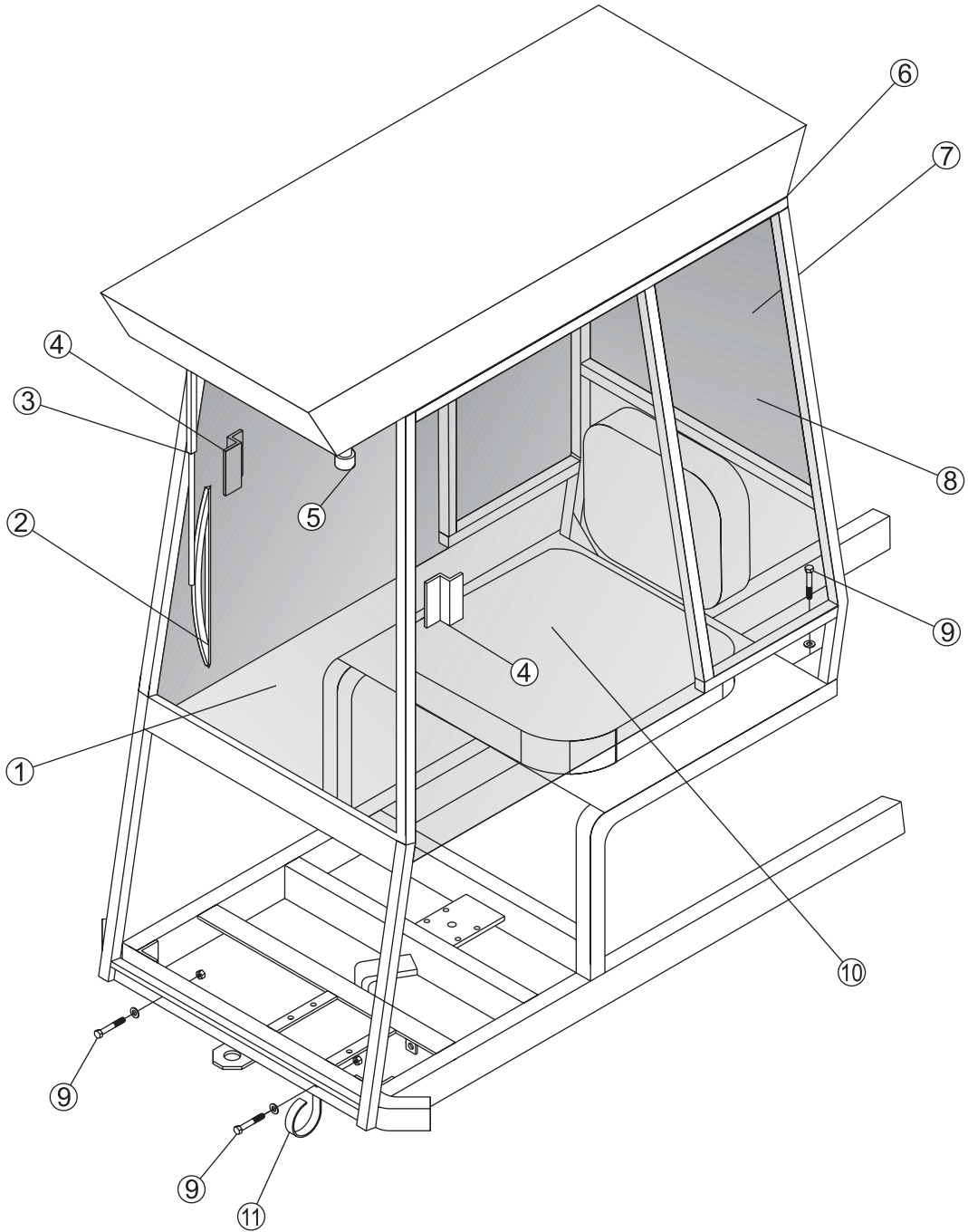

Accessories

## OPERATOR'S PROTECTIVE ENCLOSURE INSTALLATION

1. Remove cab from shipping pallet. Carefully remove band holding doors closed and save. Bands must be used to keep doors closed when in transport.
2. Park Spray Star on a level surface, set park brake and remove key.
3. Remove two screws from rear of engine cover, furthest from seat.
4. With three to four people, lift cab over front of machine and move it to rear, until lower cross member of cab comes into contact with front bumper. Lower cab until front rests on tow hook and back on the rear engine cover.
5. Center cab left to right. Clamp cab to front bumper of Spray Star. Make sure that it is still centered. Using mount holes in cab as guides drill two  $1\frac{3}{32}$ " holes through both walls of bumper.
6. Bolt cab to bumper. On left side of Spray Star place loom clamp with loop pointing down and a  $\frac{3}{8}$ " washer toward outside, put a  $\frac{3}{8}$  - 16 x  $2\frac{1}{2}$  bolt through with lock nut on inside. Do the same without loom clamp on right side.
7. Use holes in rear of cab as a guide and drill a  $1\frac{3}{32}$ " hole through rear engine cover and both walls of tubing each side. Make sure cab is still centered before drilling.
8. Put washers on top and run bolts down through with lock nuts under tubing. Tighten all four bolts.
9. Find red wire that comes out bottom of left front support tube on cab. Place a 8853 slide-on connector on the end of wire. Route wire through loom clamp, under the floorboard, in with wire harness and hoses up to the fuse block.
10. Plug wire into fuse block on an empty terminal and place a 30 Amp auto blade type fuse 33-273 into same position in fuse block.
11. Check to see that both the wiper and blower work. If not check ground and fuse.



**When handling the filter, to insure safety of yourself and others follow all accepted practices of chemicals that the filter has been exposed to.**

12. The filter element is located in front and above the driver. It is serviced from the outside of cab. To service filter, remove from cab.
13. The filter can be taken apart for cleaning and washed in soap and water.
14. To reassemble filter, place orange and white  $1\frac{1}{2}$ " dust lock pad into case first with orange side next to the screen, then place polysord carbon and retainer.
15. Place filter back into cab with polysord carbon facing up and screen down, tighten clamps.

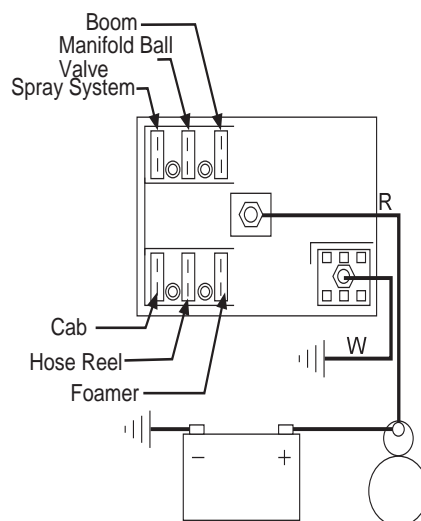

## ALTERNATOR PARTS LIST

PART#	DESCRIPTION	QUANTITY
15-473	Alternator 63Amp	1
15-475	Alternator Adjustment Bracket	1
15-344	Pump Mount Plate	1
15-478	Wire Harness (Voltmeter to Alternator)	1
15-479	Wire (Battery on Starter Solenoid to Alternator)	1
40-019	Belt	1
22-069	Nylon Ties 8"	8
HB-38-16-275	Bolt $\frac{3}{8}$ - 16 x $2\frac{3}{4}$	1
HB-516-18-125	Bolt $\frac{5}{16}$ - 18 x $1\frac{1}{4}$	2
HN-10-32	Nut 10 - 32	1
HN-516-18	Nut $\frac{5}{16}$ - 18	2
HNTL-38-16	Lock Nut $\frac{3}{8}$ - 16	1
HSM-10-32-100	Machine Screw 10 - 32 x 1	1
HW-516	Washer $\frac{5}{16}$	1
HWL-10	Lockwasher 10	1
HWL-516	Lockwasher $\frac{5}{16}$	2

## INSTALLATION INSTRUCTIONS

1. Remove key, set park brake and block rear wheels.
2. Disconnect negative (-) battery cable at battery.
3. If you jack up machine be sure to use jack stands before you go under machine.
4. On left side of machine is the spray pump. Remove guard.
5. Place a drain pan under hydraulic pump and disconnect both hydraulic hoses from pump.



### Do Not Drain Hydraulic Fluid When Hot.

#### WARNING

6. Loosen both bolts holding pump mount plate to frame. Raise pump to loosen belt and remove belt. Remove both bolts and take pump and plate out from under machine.
7. Place pump mount plate on bench. Loosen both set screws in pulley and remove pulley from pump. Be careful not to loosen the woodruff key.
8. Remove both bolts that hold pump to pump mount plate and remove plate.
9. Stand pump on end with shaft pointing up and elbow and fill plug facing you. Set new pump mount plate on pump with the both slots to the left and the slot on the end, away from you.
10. Bolt pump mount plate to pump with heads of the bolts up (against plate).
11. Put pulley on pump shaft, be sure the woodruff key is in place. With hub away from pump mount plate and  $\frac{1}{16}$  inch of clearance between pulley and heads of bolts. Tighten set screws.
12. Put  $\frac{3}{8}$  - 16 x  $2\frac{3}{4}$  bolt in hole on right side furthest from you, with head on same side of pump mount plate that the pump pulley is on. Place alternator long boss part on bolt, using  $\frac{3}{8}$  - 16 top lock nut to snug it up.
13. Place alternator adjustment bracket on pump mount plate, on same side as alternator. Use one  $\frac{5}{16}$  - 18 x  $1\frac{1}{4}$  bolt,  $\frac{5}{16}$  lockwasher and  $\frac{5}{16}$  - 18 nut with head of bolt on pump mount plate. Just snug up.
14. Use the other  $\frac{5}{16}$  - 18 x  $1\frac{1}{4}$  bolt with a  $\frac{5}{16}$  washer over slot to bolt alternator adjustment bracket to alternator with a  $\frac{5}{16}$  lockwasher and  $\frac{5}{16}$  - 18 nut. Just snug up.

## INSTALLATION INSTRUCTIONS (CONTINUED)

15. Bolt pump mount bracket with pump and alternator to back side of angle on frame that the old one came off of. Center slots and tighten.
16. Place new belt around pulleys on engine, pump, and alternator. Adjust belt tension by pivoting alternator so there is  $\frac{1}{2}$  inch deflection on belt in middle of longest span. Tighten all bolts. Check belt tension after 10 hours of use.
17. Connect both hydraulic hoses back up to pump.
18. Locate red wire coming from rectifier on lower right front of engine. Disconnect wire at coupler.
19. Remove jack stands and lower machine if you have raised it.
20. Route wire harness (voltmeter to alternator) over to steering column and under floorboard back to alternator. Be sure harness is not touching any moving or hot parts. Plug both connectors on to terminals on bottom of alternator.
21. Connect remaining wire to terminal on back of alternator and other end to battery cable terminal on starter solenoid. Be sure wires are not touching any moving or hot parts.
22. Use nylon ties to tie wiring up and out of way.
23. Put spray pump guard back on.
24. Connect negative (-) battery cable back up.

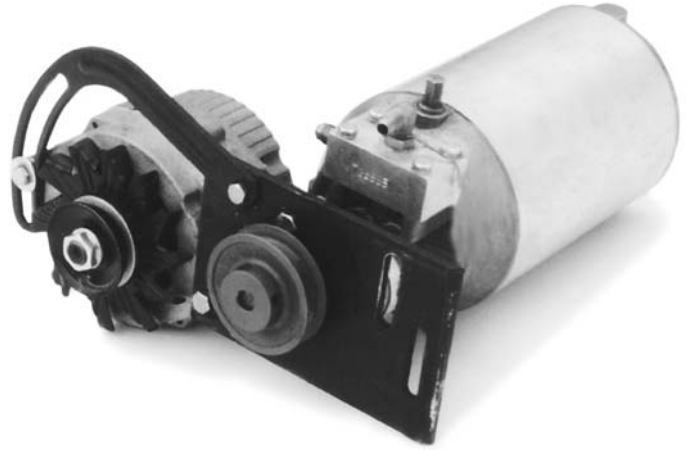

**Make absolutely certain you are connecting positive (+) to positive; negative (-) too negative while attaching power leads. If you do not observe polarity, damage will result to electrical components.**

25. Turn key on. Look at voltmeter, it should read 12 volts. Turn key to start, with engine cranking voltmeter should read 10 volts. With engine running above idle voltmeter should read around 14 volts.
26. With engine running, park brake set, and transmission in neutral, check for hydraulic fluid leaks at pump hose fittings. Correct if needed with engine off.



**Do not check for leaks with our hand. Use a narrow flat piece of wood to locate leaks. Serious injury can occur from pressurized hydraulic fluid breaking through the skin.**

27. Check oil level in hydraulic pump reservoir, remove fill plug on top and fluid level should be about  $1\frac{1}{2}$  inch from the top when fluid is cold. If fluid is needed add SAE 10W-40 API Service SJ or higher motor oil.
28. Remove blocks from wheels.

# STAR SHIELD ASSEMBLY DRAWING

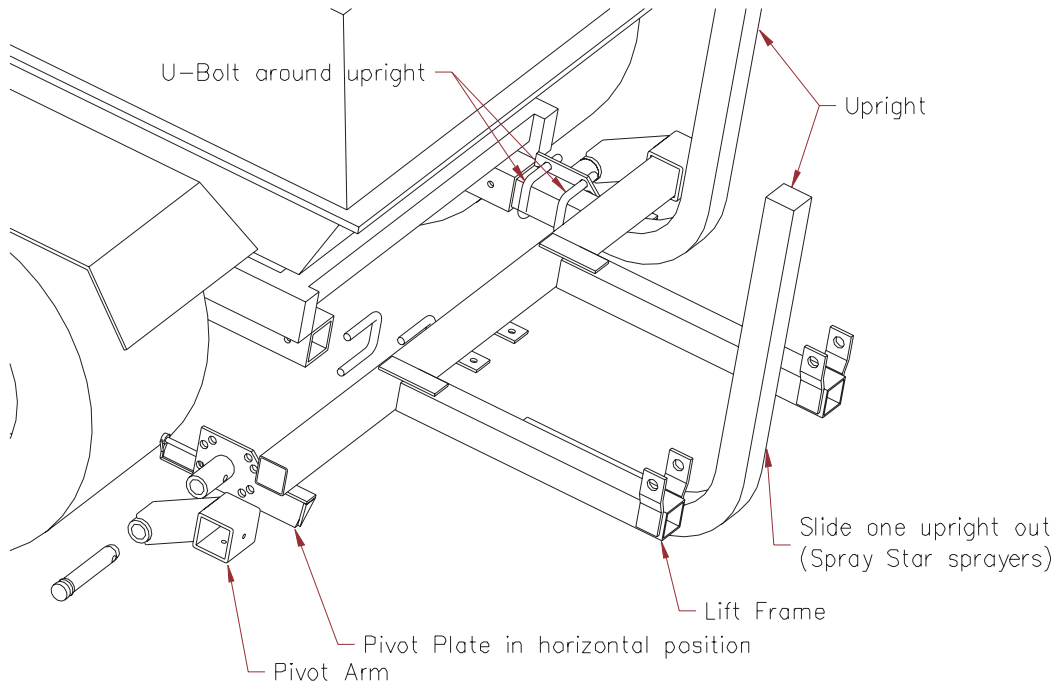

Figure 2: Lift frame attachment on Spray Star 1600 vehicle.

Accessories

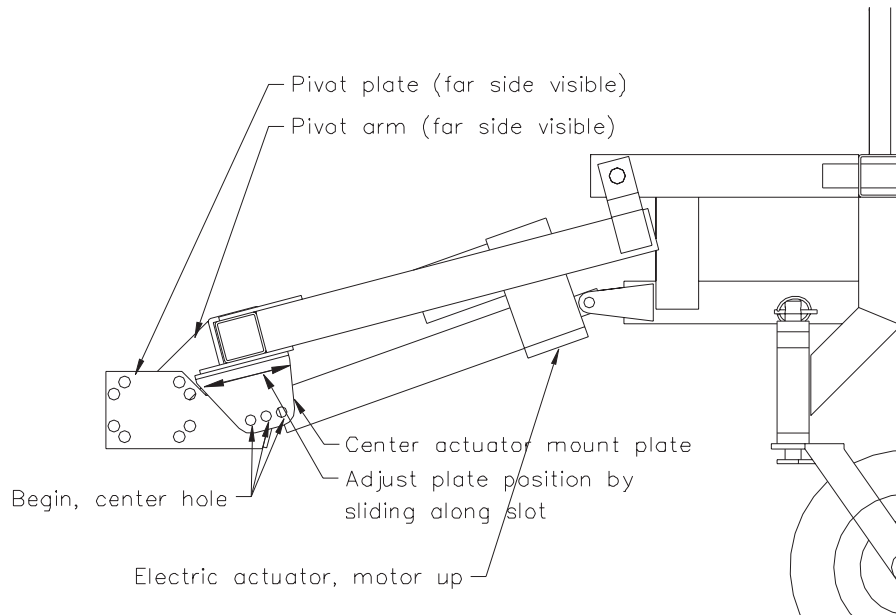

Figure 10: Center actuator position and level adjustment.



## INSTALLATION INSTRUCTIONS

1. Locate the pivot plate. The pivot plate is shipped attached with two U-bolts and is pinned to the pivot arm with a 1" top link pin.
2. The mount the plate horizontal. The center of the pin should be about **11 ½ inches** from the ground and as close to the rear wheels of the utility vehicle as possible.
3. The pivot plate may be mounted higher or lower than suggested. By mounting the pivot plate higher than suggested increases how tight the sprayer folds into the transport position. Placing the plate lower increases the amount of down float for the sprayer.
4. Locating the sprayer closer to the vehicle's rear wheels increases sprayer float but you must make sure that there is enough clearance for the sprayer to float up i.e. avoid frame, tank, solenoids or other installed attachments.
5. The plate may be mounted to the utility vehicle by U-bolting around 2 inch tubing uprights.
6. Adjust the pivot arm position by loosening the two lock bolts and sliding over the tubing of the main lift frame. Lock the pivot arm into place by tightening the bolts and locking with the jam nut.
7. Attach center actuator. For this step it will help to have someone to hold the main frame level or support the boom with blocks so the actuator can be pinned easily.
8. Begin by pinning the rod end of the actuator to the center actuator mount plates on the lift frame. Use the center hole.  
**NOTE:** Make sure there is a spacer on each side of the center actuator shaft otherwise severe damage could occur to the actuator.
9. Pin the motor end of the actuator to the main frame. Locate the motor above the rod of the actuator for clearance.

### LEVEL SPRAYER

1. When all three booms are in the spray position, adjust the booms to be level with the ground. Loosen the four nuts holding the center actuator pin plates and adjust position by sliding plates on slot and tighten securely.  
**NOTE:** Center actuator should be fully retracted while adjusting.
2. If you require more range than sliding the plates can give use the next hole in the plate. If further adjustment is required the right and left plates may be swapped giving further range.

### PLUMBING

1. Attach flow meter columns.
2. The center column assembly attaches on the solenoid bar at the rear the vehicle. (The center flow indicator has the necessary nut and bolt in the backing plate.)

### WING FLOW METERS

1. The flow indicator for each wing attaches to the wing lift frame for that wing. On the back of each wing lift frame will be two ¼" bolts and lock washers to mount the columns with.
2. Attach and route the ¾" hose from the flow monitor to the appropriate sprayer solenoid. Secure hoses with the plastic quick clamps. Tie the hose in place along the lift frame with the supplied cable ties to avoid pinching or getting caught during folding.
3. Attach and route ½" hose from flow monitor to spray nozzle. Take care to ensure that each column is routed to the appropriate spray nozzle.
4. Test folding of all sections of the sprayer for possible problems in the routing of the sprayer hose.

*(Continued on next page)*

# INSTALLATION INSTRUCTIONS

## ELECTRICAL LIFT OPTION

1. Attach electric actuators.
2. If the spray vehicle has the appropriate electric controls you may use these otherwise continue from step number 4. Hook these control up so that each switch moves the appropriate section and up and down in the direction indicated by the switch.
3. If a boom section moves in the wrong direction, the electrical connector for that section will require swapping the incoming wires.
4. Mount the control box in an accessible spot near the operators seat.
5. Route the wires with the fuse link to the battery of the vehicle. Place the red wire on the positive terminal and the blue wire on the negative battery terminal. Tie wires securely in place away from excessive sources of heat or pinch points.
6. Route the three sets of wire from the control box to the electric actuators.
7. The red and black pair of wires go to the right wing. The green and black wires go to the center actuator. The Yellow and black wires go to the left wing.

## CURTAIN INSTALLATION

1. Attach curtains to booms while in the transport position. Use generous amounts of lubricant on the rope end, or top of the curtain. (Spray silicone recommended.)
2. Start by placing one end of the curtain into the slot at the middle rear of the shield. Slide the curtain through the slot. Take care to keep feeding curtain into the slot from the start point otherwise the curtain will come out at the start point.
3. Pull curtain until the start of the curtain meets and overlaps with the end of the curtain by 1-2".
4. If the curtain has excess length double check that the curtain has not been pulled too tight and is putting extreme stress on the curtain and shield. If the curtain is too tight keep feeding curtain either forwards or backwards to release tension so the curtain hangs straight.
5. Turn curtain support straps on underside of boom down so they are pointing at the ground. These give the curtain extra support in the event of severe wind conditions.
6. Repeat for the remaining boom sections.

This is a list of decals located on the Spray Star 1600P. Part number, description and location will help in re-ordering decals.

13-063	Multiple Warning	Right Side of Seat in Front of Controls Facing Operator
14-346	Sprayer Dash	Dashboard
14-366	Control Panel	Control Panel
15-462	Hang Tag	Hang From Steering Wheel
15-463	Spray Pump	Seat Panel
14-454	Spray Star 1600	Tank Sides
16-011	Shift Knob	Shift Knob
16-088	Moving Parts Hot	Pump Guard
16-090	Bowl & Screen	Strainer Bracket
16-227	Tank Flush	Left Front Tank
16-228	Not a Motor Vehicle	In Front of seat Left Side
16-858	Caution Steering	Dashboard by Steering Column
25-279	Safety Warning	Under Seat Cover
25-286	Pinch Point	Left and Right Side Panel
25-298	Warning Hot	Right Exhaust Guard/ Right Side of Frame Next to Muffler
25-307	Gas Refuel	Below Gas Tank
25-308	Engine Speed	Engine Side
25-355	Tire Pressure 18PSI	Front Tires
25-356	Tire Pressure 20PSI	Rear Tires
25-358	Smithco	Front Nose Cone
25-361	Technical Assistance	Main Frame
27-077	Smithco - Round	Steering Wheel
27-093	Hydraulic Oil	Left Exhaust Guard by Dipstick/ Left Side Frame by Oil Reservoir

## QUICK REFERENCE REPLACEMENT PARTS

### REPLACEMENT FILTERS

78-090	Oil Filter	Kohler # 12 050 01
78-088	Air Cleaner	Kohler # 47 083 03
78-089	Pre-Cleaner	Kohler # 24 083 02
50-403	Fuel Filter	
13-288	Key Switch	Kohler # 25 099 04
76-310	Key Set	

### REPLACEMENT BELTS

16-827	Foot Clutch Belt
16-869	Spray Pump Belt
15-320	Hydraulic Pump Belt

### SEAL KITS

15-315	Hydraulic Power Unit
15-315-01	Repair Kit
15-301	Power Steering Orbital Motor
15-301-01	Seal Kit
50-456	Hydraulic Cylinder
14-267	Seal Kit
11-158 and 16-754	Linear Actuators
11-158-01	Seal Kit
50-123	Brake Master Cylinder
50-123-02	Brake Master Cylinder Repair Kit

### FLUIDS

Brake Fluid	Dot 3
Engine Oil	SAE 10W-40 API Service SJ or higher Motor Oil
Hydraulic Fluid	SAE 10W-40 API Service SJ or higher Motor Oil
Rear Axle Fluid	SAE 80W-90 Gear Lube API Service GL-5, GL-4

### OTHER PARTS

16-953	Hinged Cover On Tank with Gasket	
16-953-01	Gasket For Cover	
	Spark Plugs	Champion type RC12YC (Gap 0.040 inch (1.02mm))

## LIMITED WARRANTY

SMITHCO warrants this product to be free from defects in material and workmanship under normal use for one year from the date of purchase by the original user. (60 days if product is used for rental purposes.) All warranty claims must be handled through a SMITHCO authorized dealer or by SMITHCO, INC. All transportation charges must be paid by the purchaser.

There is no further express warranty. All implied warranties, including those of merchantability and fitness for a particular purpose, are limited to one year, (60 days if product is used for rental purposes) from the date of purchase by the original user, and to the extent permitted by law any and all implied warranties are excluded and disclaimed after the expiration of such period.

All incidental and consequential damages, including pickup and delivery of the unit, communication, mileage charges and/or rental of a replacement unit during repair, are not covered under this warranty, nor is any loss of income and/or other loss resulting from the failure of the product to function due to a warranty defect.

The following items are not covered under the SMITHCO warranty, and are warranted by their respective manufacturer.

- (a) Engine and engine parts, including starters, generators, alternators and filters.
- (b) Transaxle, differentials, gear boxes and mechanical pumps.
- (c) Hydrostatic transmissions, hydraulic pumps and motors.
- (d) Batteries.
- (e) Wheels and tires.

A copy of the warranty for the above items is furnished if necessary with each SMITHCO product.

Some states do not allow limitations on how long an implied warranty lasts, or the exclusion or limitations of incidental or consequential damages, so the above limitations or exclusions may not apply to you. This warranty gives you specific legal rights and you may also have other rights, which may vary from state to state.

Federal law now requires disclosure of the warranty which applies to this product prior to the sale to a customer. Please leave this statement attached to the product and allow the buyer to remove it after purchase.

**SMITHCO**

Wayne, Pennsylvania 19087

