



## *Owner's Manual*

# **SUPER LINER**

**44-801**

**SN: SLN224**

**Revised March, 2009**

**Product Support: 1020 Hwy 224; Humboldt, KS 66748  
1-888-422-5173 [humbindustries@sbcglobal.net](mailto:humbindustries@sbcglobal.net)**

## **TABLE OF CONTENTS**

<b>TITLE</b>	<b>PAGE</b>
Introduction	1
Safe Practices	2
Specifications	3
Mixing Instructions	4
Athletic Field Painting Pointers	4
Setting Line Width	4
Maintenance Instructions	5
Operating Instructions	5
Troubleshooting	6
44-801 Main Frame Drawing	7
44-801 Main Frame Parts List	8-9
Axle Drawing	10
Axle Parts List	11
44-801 Plumbing Drawing	12
44-801 Plumbing Parts List	13-14
40-610 Transaxle Drawing	15-16
40-610 Transaxle Parts List	17-18
40-610 Transaxle (Drawing I)	19
40-610 Transaxle (Drawing II)	20
44-801 Wiring Diagram	21
44-801 Wiring Parts List	22
49-027 Gun & Hose Kit	23
Boom Drawing	24
Boom Parts List	25

# INTRODUCTION

Thank you for purchasing a **SMITHCO** #44-801 Super Liner.

Carefully read this manual and the engine manual as they include safety, operating, assembly and maintenance instructions. Failure to do so could result in personal injury or equipment damage.

Keep manuals in a safe place after operator and maintenance personnel have read them. Right and left sides are from the operator's seat, facing forward.

All **SMITHCO** machines have a Serial Number and Model Number. Both numbers are needed when ordering parts. The serial number plate on the #44-801 Super Liner is located under the manifold console, on the left side wall of the liner.

For easy access, record your Serial and Model numbers here.

<b>SMITHCO</b>		DATE OF MFG.
WAYNE, PENNSYLVANIA 19087 USA		<input type="text"/>
610-688-4009 FAX 610-688-6069		
SERIAL NO.	kw/hp	
<input type="text"/>	<input type="text"/>	
MODEL NO.	kg/lb	
<input type="text"/>	<input type="text"/>	

Information needed when ordering replacement parts:

1. Model Number of machine.
2. Serial Number of machine.
3. Name and Part Number of part.
4. Quantity of parts.
5. Ship Via

## **SAFE PRACTICES**

1. **It is your responsibility to read this manual and all publications associated with this machine (engine and accessories).**
2. Never allow anyone to operate or service the machine or its accessories without proper training and instructions. Never allow minors to operate any equipment.
3. Learn the proper use of the machine, the locations and purpose of all the controls before you operate the equipment. Working with unfamiliar equipment can lead to accidents.
4. Wear all the necessary protective clothing and personal safety devices to protect your head, eyes, ears, hands and feet. Operate the machine only in daylight or in good artificial light.
5. Inspect the area where the equipment will be used. Pick up all debris you can find before operating. Beware of overhead obstructions and underground obstacles. Stay alert for hidden hazards.
6. Never operate equipment that is not in perfect working order or without decals, guards, shields, or other protective devices in place.
7. **Never disconnect or bypass any switch.**
8. Carbon monoxide in the exhaust fumes can be fatal when inhaled, never operate a machine without proper ventilation.
9. Fuel is highly flammable, handle with care.
10. Keep engine clean. Allow the engine to cool before storing and always remove the ignition key.
11. After engine has started machine must not move. If movement is evident, the neutral mechanism is not adjusted correctly. Shut engine off and readjust so the machine does not move when in neutral position.
12. Never use your hands to search for oil leaks. Hydraulic fluid under pressure can penetrate the skin and cause serious injury.
13. This machine demands your attention. To prevent loss of control or tipping of the vehicle:  
Use extra caution in backing up the vehicle. Make sure area is clear. Do not stop or start suddenly on any slope. Avoid driving sideways on hills as much as possible.  
Reduce speed on slopes and in sharp turns. Use caution when changing directions on slopes.  
Stay alert for holes in the terrain and other hidden hazards.
14. Before leaving operator's position for any reason:  
Disengage all drives.  
Shut engine off and remove the ignition key.
15. Keep hands, feet and clothing away from moving parts. Wait for all movement to stop before you clean, adjust or service the machine.
16. Keep the area of operation clear of all bystanders.
17. Never carry passengers.
18. Stop engine before making repairs/adjustments or to check or add oil to the crankcase.
19. **Use parts and materials supplied by SMITHCO only. Do not modify any function or part.**

These machines are intended for professional maintenance on flat grass athletic fields. Other use will void the warranty.

## **SPECIFICATIONS**

### **SUPERLINER SPECIFICATIONS**

#### **MODEL #44-801**

#### **Weight and Measurements**

Length 74" overall (without boom)  
Width 44" overall (without boom)  
Ground Clearance 7"  
Weight 610 lbs; Crated - 1090 lbs

#### **Tires**

2 front wheels - 16 x 6.50 x 8; 2 ply; wide track; 2 rear wheels - 20 x 10 x 8; 2 ply; wide track

#### **Wheel Base**

45" (Turning Radius 10')

#### **Drive**

Hydrostatic drive; Eaton 851 transaxle.

#### **Controls**

Advanced Quadro Z-Gate

#### **Brakes**

Dynamic braking, through hydrostatic transaxle with parking brake

#### **Seat**

One piece, back support, adjustable.

#### **Body**

Heavy, strong steel.

#### **Ground Speed**

0- mph (0 to 11 khp)

#### **Compressor**

12 V air compressor

#### **Engine**

16 hp Briggs & Stratton

#### **Tilt Steering**

Chain and sprocket system

#### **Paint Tank**

35 gallon stainless steel compressed air tank

#### **Two Spray Boxes**

Front-mounted and side-mounted; paint line widths 2" to 5"; easy adjustment with double spray nozzles for water based paint only

### **ACCESSORIES**

#### **Line Guide**

Line-up guide rod extends forward to guide operator when painting lines.

#### **Hose and Gun Kit**

Model 49-027 – pistol-grip spray gun with 24" extension pipe and 12 ft. hose; for painting numbers and designs; and weed control spraying

## **MIXING INSTRUCTIONS**

USE ONLY TOP QUALITY WATER-BASED LATEX ATHLETIC FIELD PAINT. CHOOSE WATER BASED, NON-TOXIC, NON-PHYTOTOXIC PAINT. **INFERIOR PAINT VOIDS SMITHCO WARRANTY.**

NOTE: The operator must familiarize himself with the procedures below before starting the unit. The Super Liner should be run in a practice area using water only until the operator is fully familiar with its operation.

- A. Completely follow mixing instructions on painting container.
- B. Never use mixed paint without straining.
- C. The depth of the color of the line will be determined by the percentage of water added to the paint. Because of the variation in paints, the user must determine the consistency for himself. In most cases, the mix should be at least two parts water to one part paint. NEVER use more than 50% paint.
- D. Use spraying nozzle TeeJet 8004EVS tip only. These tips have been tested and work the best with the SMITHCO pumping system.
- E. Fill tank with desired amount of water.
- F. Pour strained paint into tank slowly to properly mix.
- G. Always drain and flush the entire paint system with water after each use for at least 5 minutes or until water runs clear.
- H. The nozzle tips should be removed for cleaning.
- I. Do not leave paint mixture in tank overnight.
- J. If possible, check with you local environmental and hazardous waste office for proper disposal of paint waste material.

**WARNING: NEVER OPEN TANK LID WHEN UNDER PRESSURE.**

## **ATHLETIC FIELD PAINTING POINTERS**

- H. To achieve the best results, and minimize turf damage, use an athletic field marking paint. Choose water based, non-toxic, non-phytotoxic paint.
- I. Mix paint thoroughly with the proper amounts of water to maintain uniform coverage and color throughout the job. Dilution ratios will vary; changes are usually determined from experience. When using TOP QUALITY SPORTS TURF PAINT, for new lines, a lower dilution ratio will be more effective of 2 parts water to 1 part paint. For relining a higher percentage of water may be suitable.
- J. Preset the lines to be painted using a strong nylon string.
- K. Turf Growth Regulators (TGR) or Plant Growth Regulators (PGR) may be used to reduce turf growth when added to paint.

## **SETTING LINE WIDTH**

1. The line width desired can be set by loosening the thumb screw on spray box and moving the spray tips up and down or adjusting boom flap.
2. Locate the line guide squarely in the middle of the line intended. The line guide can be adjusted by sliding the rod to the desired position and then locking with the thumb screws provided.

## **MAINTENANCE INSTRUCTIONS**

**NOTE: IF MACHINE IS TO BE LEFT MORE THAN ONE HOUR, SYSTEM SHOULD BE FLUSHED. DO NOT LEAVE PAINT IN SYSTEM OVER NIGHT.**

1. After each day's use, follow instructions below.
  - A. Open drain valve, located at the bottom of paint tank, draining remaining paint into clean sealable container. (**NOTE: NEVER OPEN DRAIN WHEN TANK IS UNDER FULL PRESSURE.**)
  - B. Flush paint tank with fresh water for five minutes with drain valve open, until all paint residue is out of the tank. (This can be done with the flush hose kit.)
  - C. Close drain valve and fill paint tank with clean water.
  - D. Turn selector valve to flush position.
  - E. Turn on pump switch.
  - F. Turn on paint switch; flush tips until water flows clear.
  - G. Turn paint switch to off. Allow pump to agitate water in paint tank.
  - H. Open drain valve at bottom of paint tank once again, drain water to just below agitators and the BE SURE to turn off pump. Allow tank to drain completely and close drain valve.
  - I. Remove spray tips from both booms. Clean thoroughly with a soft bristle brush and soapy water.
  - J. Leave at least 5 gallons of water in tank after cleaning. This will prevent any paint from drying in the system.
2. Lubricate the following:
  - A. Steering shaft bearings. (Located on pg. , Steering and Tank Drawing, )
  - B. Hub bearings (Front). (Located on pg. , 44-701 Drive Train Drawing, # )
  - C. Boom arms (Both). (Located on pg. , Main Boom Assembly, # )
  - D. Front axles (Left and Right). (Located on pg. , Drive Train Drawing, # )
3. See engine manual for maintenance instructions on engine.
4. When storing unit after the painting season, the battery should be disconnected.
5. For winter storage, the unit and nozzle tips must be thoroughly cleaned and flushed.

**WARNING: NEVER OPEN TANK LID WHEN UNDER PRESSURE.**

The Transaxle requires 10W40 Oil.

## **OPERATING INSTRUCTIONS**

- A. Set speed control lever to neutral position. **NOTE: IF UNIT DOES NOT START, CHECK TO ENSURE NEUTRAL IS SET.**
- B. Turn key switch to start unit, allow unit to warm up for 3 minutes.
- C. Select front or side boom by using selector valve on side of unit.
- D. Engage pump switch to "ON" position to begin agitation.
- E. Lower desired boom by using one of the switches located on the left side of the steering column.
- F. **DO NOT PAINT** until unit is moving in the desired line of travel.
- G. Depress foot switch to start or stop painting.
- H. Increase and decrease paint flow to desired pressure by using the valve on left hand side. ±

## **TROUBLESHOOTING**

There are a number of variables affecting the line density if it is not satisfactory.

- A. Paint may be inferior: Paint mixture may be too thick or too thin.
- B. Hoses or tips may be clogged: Tips must be clean. System may need to be flushed, or paint may need to be restrained.
- C. Nozzle tips may be worn out: Replace with TeeJet 8004EVS stainless steel.
- D. Reducing speed increases paint applied. Increasing speed decreases paint applied.
- E. Proper lining color should be ascertained in the field, because of variations in marking paint and the percentage of water added. Never use more than 50% paint.
- F. Unit will not start if speed control lever is NOT IN NEUTRAL.
- G. If unit is not building pressure, then check to make sure that the compressor switch is on.
- H. If switch is on and compressor is still not building pressure then remove cover on the compressor and check reset.

**NOTE:** If you have any further questions, please contact our **SMITHCO** Technical Consultant at 1-888-422-5173.



# 44-801 MAIN FRAME DRAWING

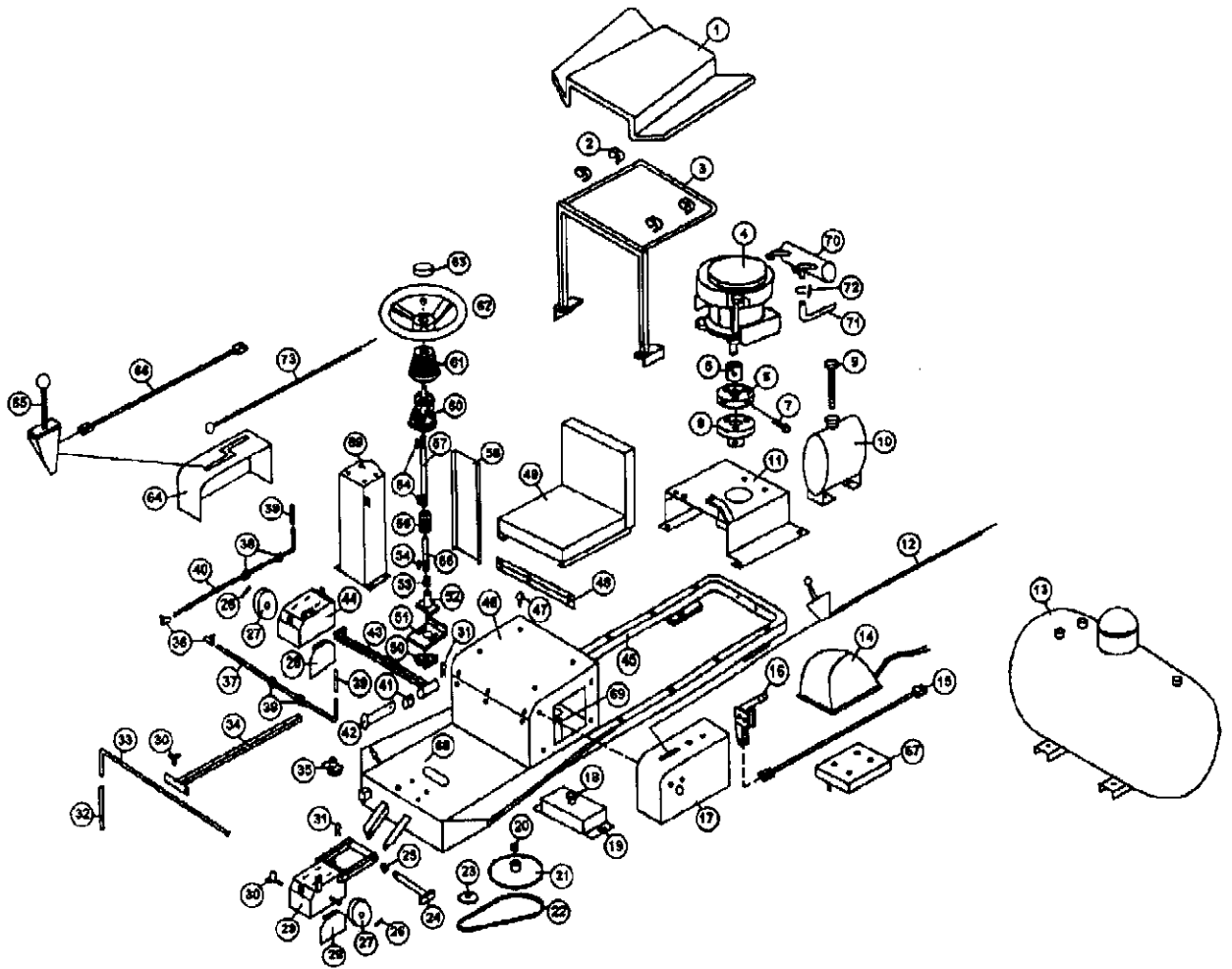

## 44-801 MAIN FRAME PARTS LIST

REF.#	PART#	DESCRIPTION	QTY.
1	44-751	Engine Cover	1
2	44-748	Cover Latch	4
3	44-752	Engine Cover Bracket	1
4	44-825	Vanguard Vertical Shaft Engine	1
5	740-020	1" Coupler (Engine)	1
6	740-022	Rubber Element	1
7	740-022-1	Bolt Hub Set	1 Set
8	740-021-17	Hub 17 mm	1
9	41-104	Gas Cap w/Gauge	1
10	44-853	Gas Tank Assy	1
11	44-732	Engine Base	1
12	750-715	Throttle Cable	1
13	44-810	Paint Tank	1
14	44-815-1	1.3 CFM Compressor	1
15	44-719	Shift Cable	1
16	44-763	Parking Brake Lever	1
17	44-737	Throttle Control Box	1
18	750-118-1	Oil Tank Cap	1
19	750-118	Oil Tank	1
20	2110	Pivot Post Bearing 3/4" ID	1
21	41-198	Steering Sprocket	1
22	41-251	Chain #40 x 108 Pitch	1
23	1075	#40 Sprocket 11T	1
24	41-243-1	Mounting Pin	1
25	2110	Pivot Post Bearing 3/4" ID	2
26	40-168	Cotter Pin 1/8" x 1"	3
27	49-017	Caster Wheel 8"	3
28	44-305-1	Boom Flapper	4
29	41-310-1	Double Tip Front Boom Box	1
30	400-060	5/16" - 18 x 1" Thumb Screw	4
31	2050	Snap Pin	2
32	8802	1/2" Clear Vinyl Hose	10"
33	40-151	Line Guide Rod	1
34	40-189	Line Guide Arm	1
35	44-722	Paint Switch	1
36	44-822	Connecting Rod	4
37	44-818	Side Boom Lift Rod	1
38	44-821	3/8" Steel Shaft Collar	4
39	40-038	Round Grip	2
40	44-817	Front Boom Lift Rod	1
41	2110	Pivot Post Bearing 3/4" ID	1
42	44-757	Side Boom Mounting Pin	1
43	44-756	Side Boom Lift Arm	1

**44-801 MAIN FRAME PARTS LIST (Continued)**

<u>REF.#</u>	<u>PART#</u>	<u>DESCRIPTION</u>	<u>QTY.</u>
44	44-727	Side Mount Boom	1
45	44-823	Main Frame	1
46	44-743	Seat Plate	1
47	41-143	Protective Bumper	2
48	44-744	Hinge	1
49	832-123	Low-Back "SMITHCO" Seat	1
50	1036	Jackshaft Bearing	1
51	41-194	Chain Adjuster Bracket	1
52	750-195	Steering Tube	1
53	2110	Pivot Post Bearing ¾" ID	1
54	1088	3/16" x 1" Key	3
55	41-193	Steering Sprocket Shaft	1
56	41-120	U-Joint ¾" x ¾"	1
57	44-770	Steering Shaft	1
58	750-107	Steering Column Cover	1
59	44-731	Steering Column	1
60	832-028	Tilt Steering	1
61	832-029	Boot	1
62	730-046	Steering Wheel	1
63	730-046-1	Steering Wheel Cap	1
64	44-736	Shift Control Box	1
65	44-718	Shift Lever	1
66	44-719	Shift Cable	1
67	44-828	Pump Plate	1
68	750-153	Rubber Mat	1
69	720-074	Battery Box	1
70	943-115	Muffler	1
71	943-145	Tailpipe	1
72	943-146	Muffler Clamp	1
73	943-126	Choke Cable	1

# AXLE ASSEMBLIES DRAWING

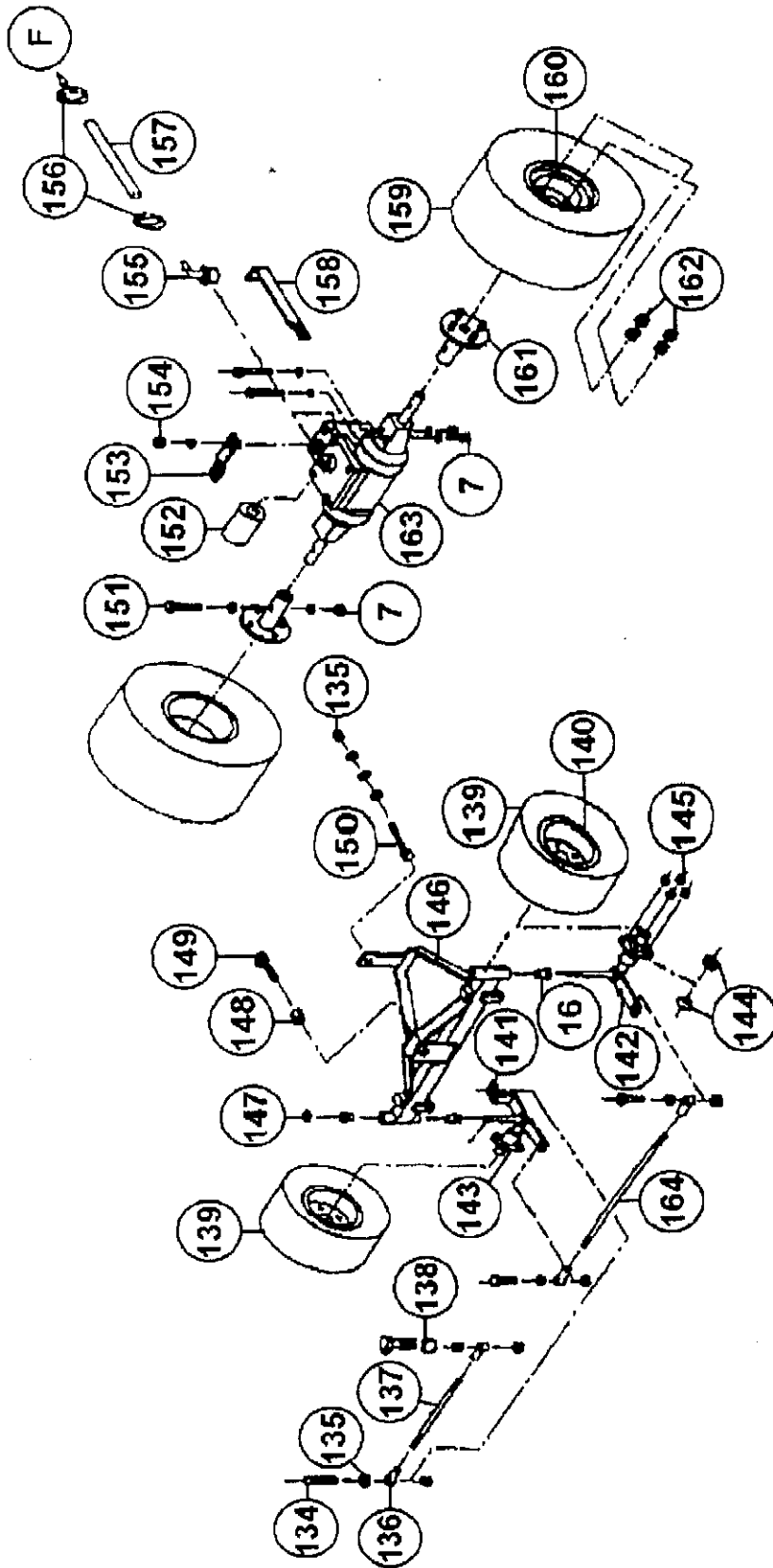

## AXLE ASSEMBLIES PARTS LIST

REF.#	PART#	DESCRIPTION	QTY.
1	44-745	Wheel & Tire	2
2	40-615	Oil Filter	1
3	44-721	Transaxle Bar	1
4	400-116	3/8" - 16 x 3 1/2" Lock Nut	1
5	400-020	3/8" - 16 x 3 1/2" Bolt	4
6	400-027	1/2" - 13 x 1 1/2" Bolt	1
7	44-740	Support Arm	1
8	41-196	Rear Hub	2
9	40-610	Transaxle	1
10	44-746	Rear Tire 22 x 11 x 8	2
11	44-747	Rear Wheel	2
12	1187	Rear Lug Nut	8
13	41-218	Bearing	4
14	44-733	Front Axle Crossmember	1
15	44-734	Front Axle Left	1
16	2775	Front Wheel	2
17	2780	Front Tire	2
18	1187	Front Lug Nuts	8
19	2027H	Hub Only	2
20	709-171	Front Seal	2
21	41-218	Front Bearing	4
22	400-056	1/2" x 2 1/2" Bolt	4
23	400-112	1/2" Lock Nut	8
24	713-806	Ball Joint	4
25	44-723	Steering Rod	1
26	44-725	Steering Tie Rod	1
27	2027	Hub Assy.	2
28	44-735	Front Axle Right	1
29	2774	Front Wheel & Tire	2
30	2024	Grease Cap	2
31	41-222	Seal	4

**44-801 PLUMBING DRAWING**

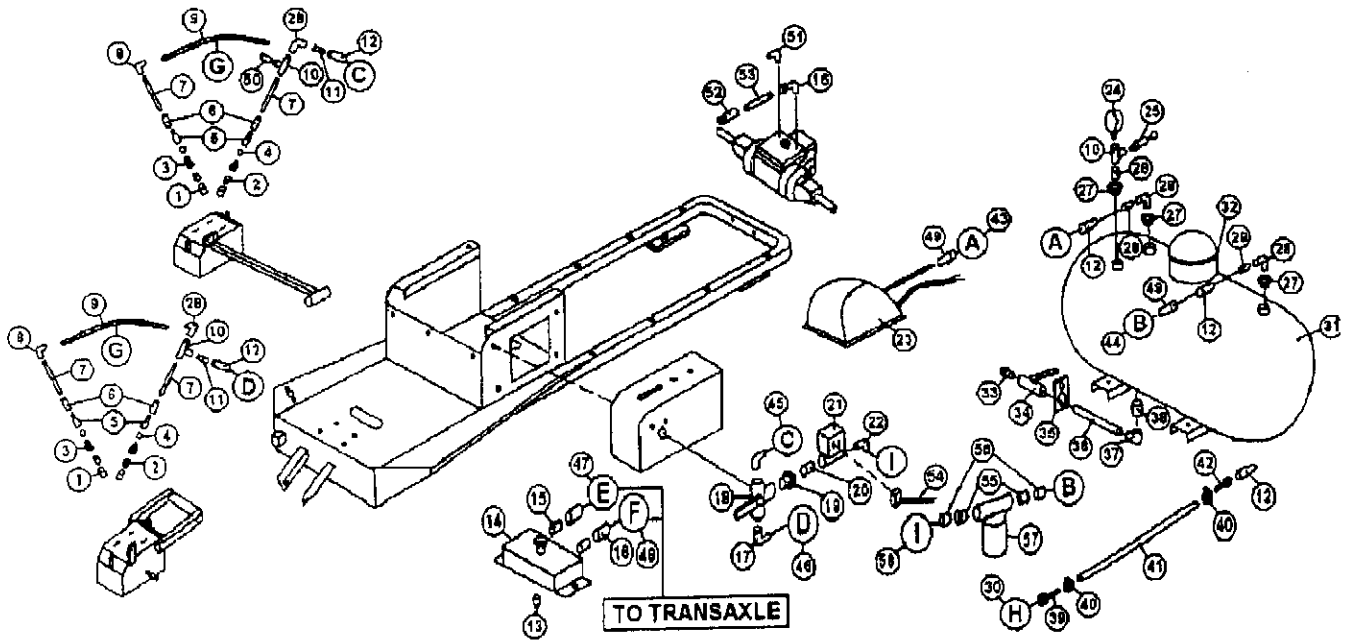

**44-801 PLUMBING PARTS LIST**

<b>REF.#</b>	<b>PART#</b>	<b>DESCRIPTION</b>	<b>QTY.</b>
1	19-680	Brass Nozzle Cap	4
2	709-053-8004EVS	Nozzle Tip	4
3	19-699	Spring	4
4	19-698	Ball	4
5	19-697	Nozzle Body, Brass	4
6	500-314	¼" Black Coupler	4
7	500-243	¼" x 4" Nipple	4
8	500-400	¼" Elbow Gal.	2
9	44-888	¼" x 13" Boom Box Hose (G)	2
10	18-012	¼" Brass Tee	3
11	18-011	¼" Close Nipple	1
12	44-008	Plug	4
13	500-603	3/8" Plug Gal	1
14	750-118	Oil Tank	1
15	44-877	3/8" x #8 Oil Tank Fitting	2
17	44-876	90° Street Elbow	2
18	44-811	½" 3-Way Ball Valve	1
19	500-111	¼" x ½" Bushing	1
20	18-011	¼" Close Nipple	1
21	41-118	Electric Valve	1
22	44-876	¼" Street Elbow	1
23	44-815-1	1.3 CFM Compressor	1
24	706-079	100 PSI Gauge	1
25	40-385	Relief Valve	1
26	18-011	¼" Close Nipple	1
27	500-111	½" x ¼" Bushing	2
28	18-007	¼" Brass Street Elbow	4
29	18-011	¼" Close Nipple	1
30	44-850	½" Clean Out Hose (H)	1
31	44-810	Tank	1
32	44-851	O-Ring	1
33	707-050	½" x ¾" GHT Fitting	1
34	709-257	½" Ball Valve	1
35	601-180	Suction Line Support	1
36	500-556	½" x 12" Nipple	1
37	500-401	½" x 90 Elbow	1
38	500-508	½" x 4" Nipple	1
39	709-337	½" Femal Hose Fitting	1
40	709-312	½" Hose Clamp	2
41	642	½" Hose	60"
42	709-303	¼" NPT x ½" Barb	1

## 44-801 PLUMBING PARTS LIST (Continued)

REF.#	PART#	DESCRIPTION	QTY.
43	44-852	¼" Clear Compressor Hose (A) 30"	1
44	44-885	3/8" x 34" Hose Tank to Strainer (B)	1
45	44-883	3/8" x 49" Boom Hose (C)	1
46	44-883	3/8" x 49" Boom Hose (D)	1
47	44-887	½" x 27" Hose Oil Tank to Transaxle (E)	1
48	44-886	½" x 33" Hose Oil Tank to Transaxle (F)	1
49	44-007	Socket	4
50	44-879	¼" x #4 Fitting	2
51	750-207	Fitting (Right Hand Side Axle) 90° Fitt.	2
54	44-119	Electric Valve Wiring	1
55	500-103	¾" x ½" Bushing	2
56	44-875	Strainer Fitting	2
57*	44-865	Strainer	1
58	44-884	3/8" x 24" Hose Strainer to Electric Valve (I)	1

\*NOTE: THE 44-865 Strainer is made up of the following:

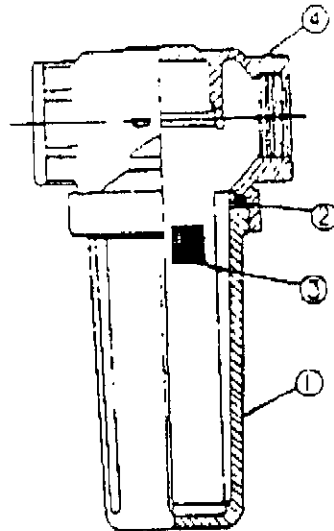

REF.#	PART#	DESCRIPTION	QTY.
1	44-865-3	Bowl	1
2	44-865-4	Screen	1
3	44-865-1	O-Ring	1
4	44-865-2	Head	1



# 40-610 TRANSAXLE DRAWING

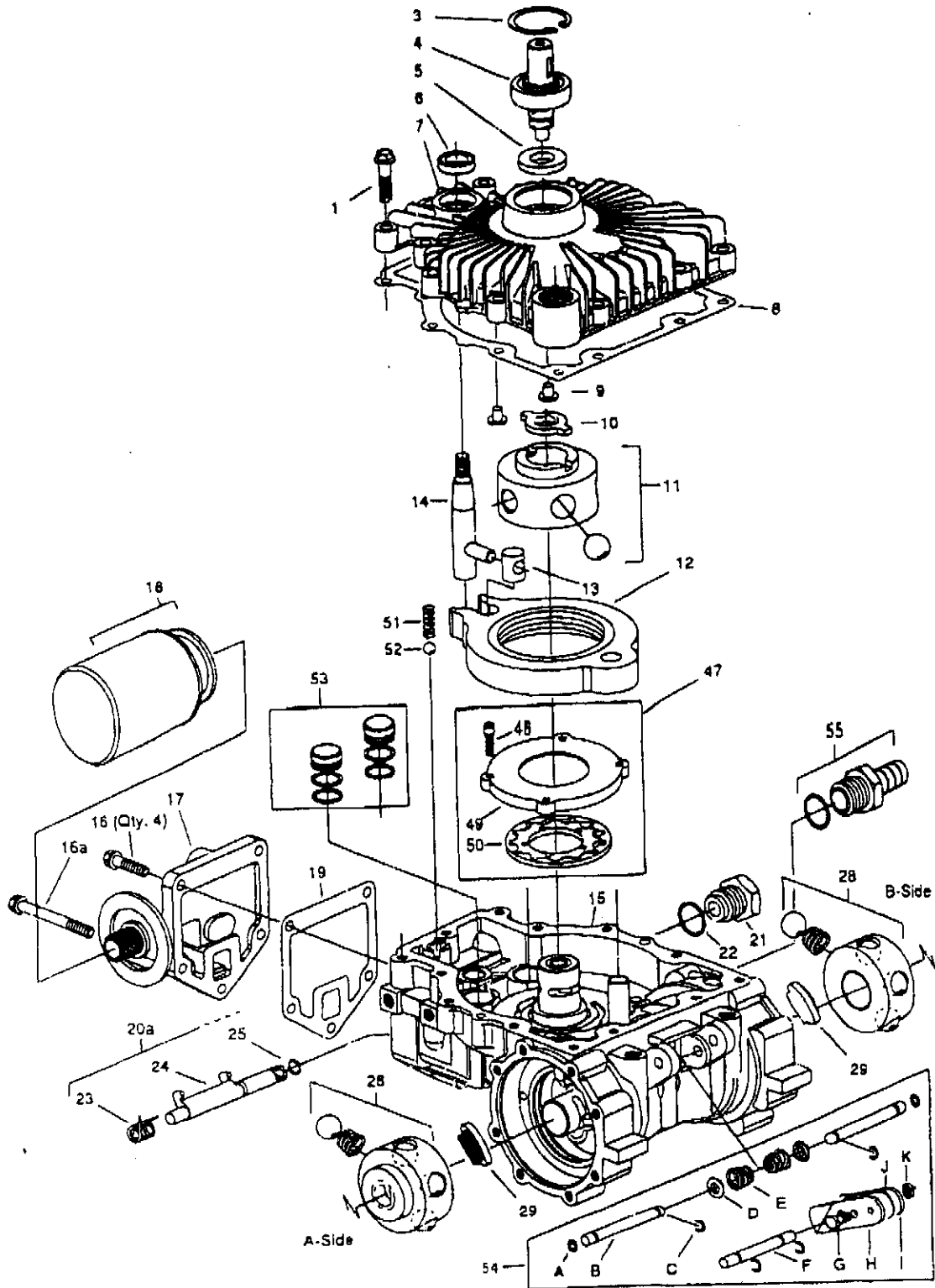

# 40-610 TRANSAXLE DRAWING

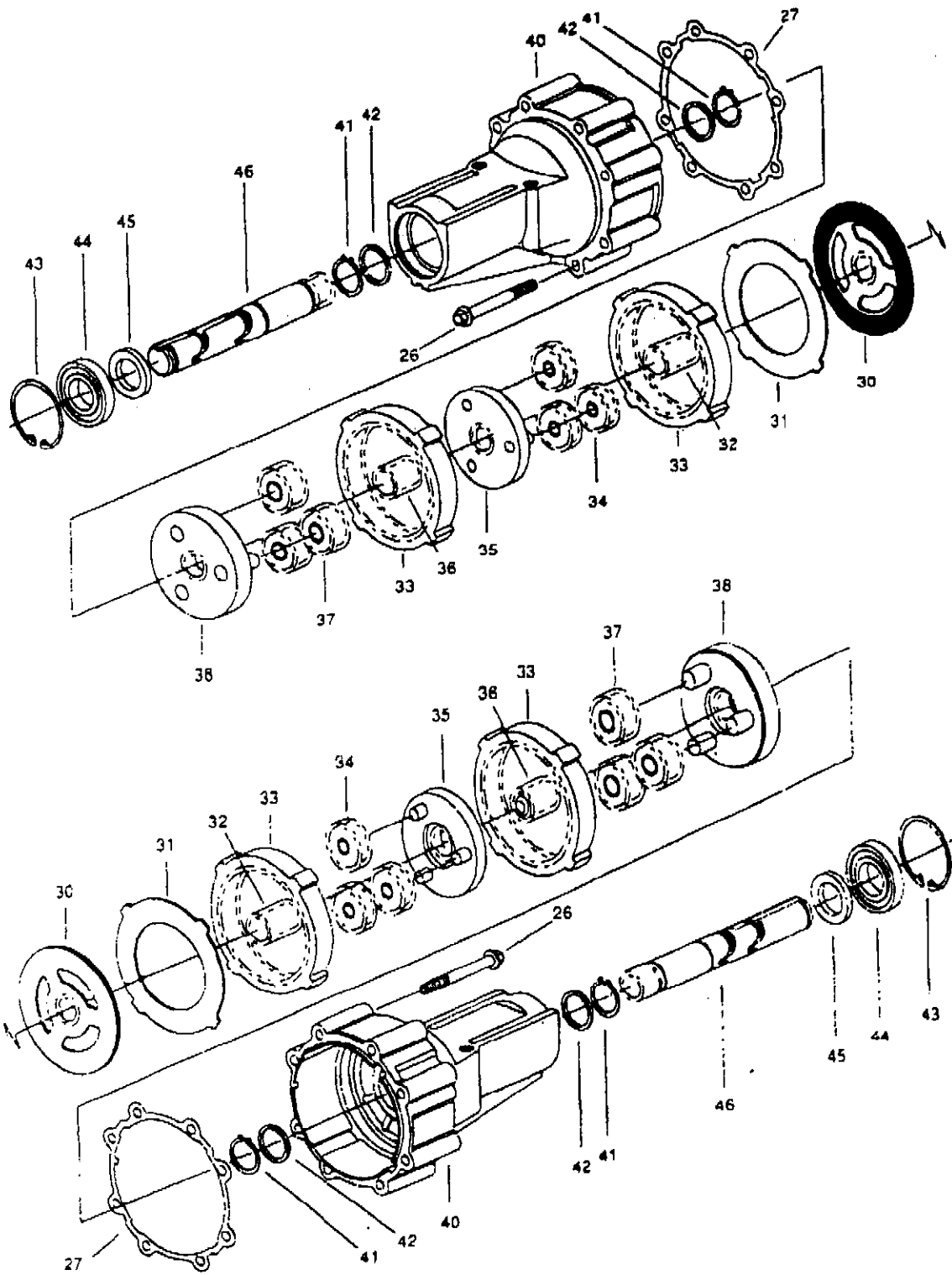

## 40-610 TRANSAXLE PARTS LIST

REF#	PART#	DESCRIPTION	QTY.
1	40-610-1	Screw, ¼" – 20 Self Tap	13
2	40-610-5	Cover	1
3	40-610-3	Retaining Ring	1
4	40-610-4	Input Shaft	1
5	40-633	Input Shaft Seal	1
6	40-610-6	Control Shaft Seal	1
7	40-610-7	Cover	1
8	40-610-8	Cover Gasket	1
9	40-610-9	Button	2
10	40-610-10	Drive	1
11	40-610-2	Pump Rotor / Ball / Pin	1
12	40-610-12	Cam Ring	1
13	40-610-13	Insert	1
14	40-610-14	Control Shaft, External Thrd.	1
15	40-610-15	Housing	1
16	40-610-16	Screw, ¼ - 20 Hex Flange	4
16A	40-610-16A	Screw, ½ - 20 Hex Flange	1
17	40-610-17	Filter Base "L"	1
18	40-610-18	Filter	1
19	40-610-19	Gasket	1
21	40-610-21	Nut, Dump Valve Fitting	1
22	40-610-22	O-Ring Seal	1
23	40-610-23	Dump Valve Spring	1
24	40-610-24	Dump Valve Bracket	1
25	40-610-25	O-Ring Seal	1
26	40-610-26	Screw 5/16 Hex Flange	16
27	40-626	Axle Housing Gasket	2
28	40-610-28	15T Motor Rotor / Ball	2
29	40-610-29	Friction Pad	2
29A	40-610-29A	Spacer	2
30	40-610-30	Reaction Plate	2
31	40-610-31	Backup Plate	2
32	40-610-32	First 15T Sun Gear	2
33	40-610-33	Ring 57T Gear	4
34	40-610-34	21T Planet Gear First	6
35	40-610-35	15T Primary Carrier	2
36	40-610-36	Second 15T Sun Gear	2
37	40-610-37	Second 21T Pint Gear	6
38	40-610-38	Secondary Carrier	2
40	40-610-40	Axle Housing	2

**40-610 TRANSAXLE PARTS LIST (Continued)**

<b>REF#</b>	<b>PART#</b>	<b>DESCRIPTION</b>	<b>QTY.</b>
41	40-627	External Retaining Ring	4
42	40-610-42	Thrust Washer	4
43	40-630	Internal Retaining Ring	2
44	40-629	Ball Bearing	2
45	40-628	Radial Lip Seal	2
46	40-625	Axle Shaft – A-Side	1
47	40-610-47	Charge Pump	1
48	40-610-48	Socket Cap Screw	4
49	40-610-49	Pump Plate	1
50	40-610-50	Gerotor	1
51	40-610-51	Spring	1
52	40-610-52	Ball	1
53	40-610-53	Dampening Piston	2
54	40-610-54	Brake Lever Parts Kit	1
54A	40-610-54A	Quad Seal	2
54B	40-610-54B	Push Rod	2
54C	40-610-54C	E-Ring	4
54D	40-610-54D	Spring Base	2
54E	40-610-54E	Conical Spring	2
54F	40-610-54F	Brake Shaft	1
54G	40-610-54G	Hex Cap Screw	1
54H	40-610-54H	RH Brake Lever	1
54I	40-610-54I	LH Brake Lever	1
54J	40-610-54J	Shim	2
54K	40-610-54K	Hex Lock Nut	1
55	40-610-55	.625 Str. Fitting / O-ring	1

**40-610 TRANSAXLE ( Drawing I )**

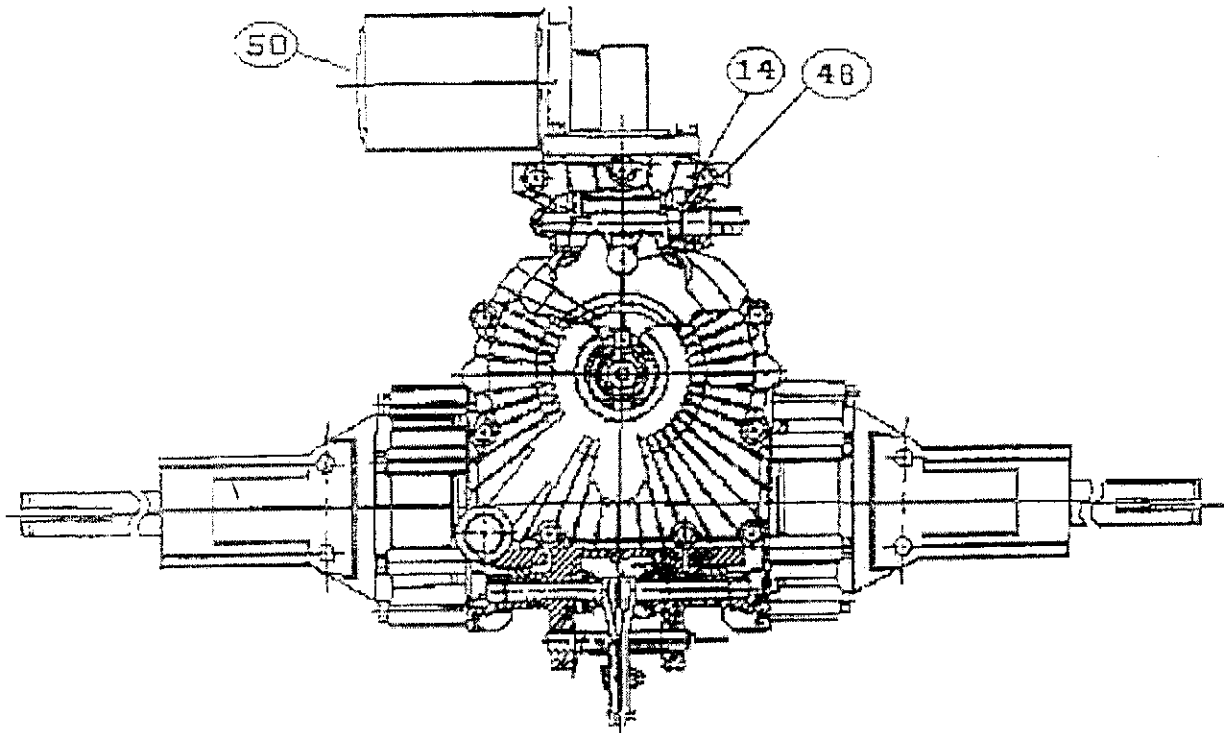

REF.#	PART#	DESCRIPTION	QTY.
14	40-616	O-Ring	1
48	40-417	Tube Fitting O-Ring	1
50	40-615	Oil Filter	1

**40-610 TRANSAXLE ( Drawing II )**

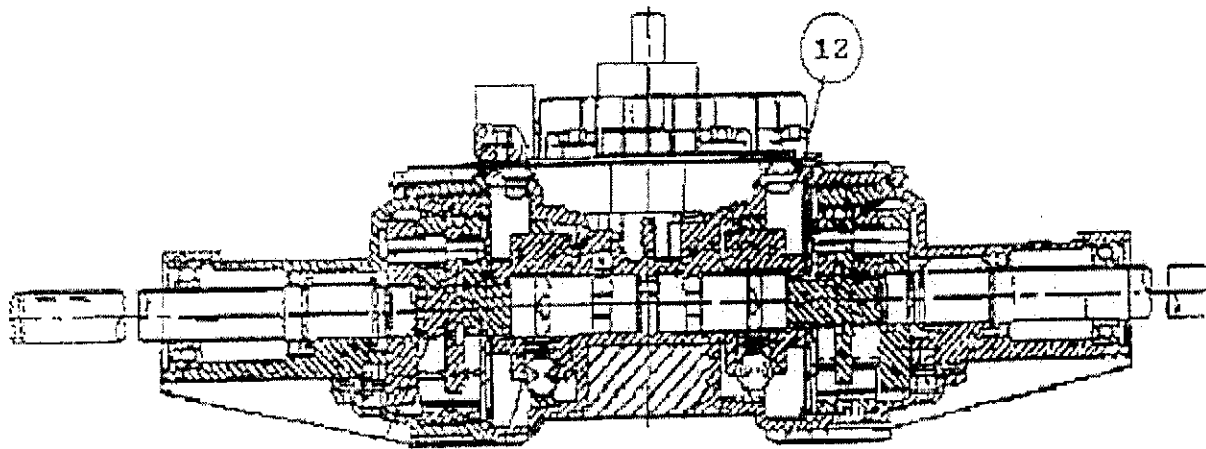
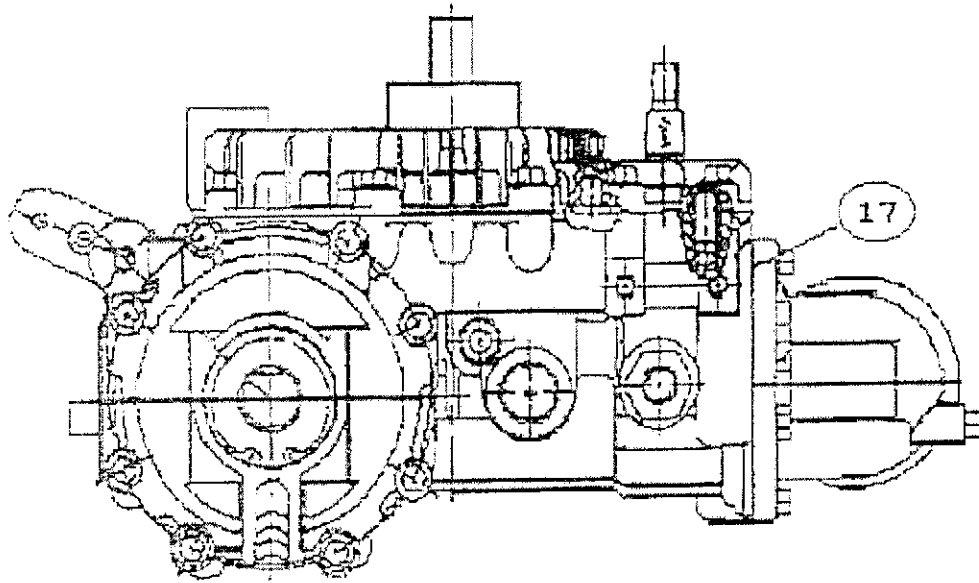

REF.#	PART#	DESCRIPTION	QTY.
17	40-618	Gasket, Filter Base	1
12	40-619	Cover Gasket	1



## **SUPER LINER WIRING PARTS LIST**

<b>REF.#</b>	<b>PART#</b>	<b>DESCRIPTION</b>	<b>QTY.</b>
1	932-071	Key Switch	1
2	W094	3-Way Connector	1
3	2070	Ignition Switch 2-Post	1
4	41-119	Electric Valve Wiring	1
5	41-118	Electric Valve	1
6	44-722	Paint Switch	1
7	2082	Solenoid	1
8	44-864	Engine 6ga Wire	1
9	44-861	Positive Battery Wire	1
10	44-862	Ground Wire	1
11	720-076	Battery	1
12	44-718	Shift Lever	1
13	44-815-1	1.3 CFM Compressor	1
14	44-825	Vanguard Vertical Shaft	1
15	44-863-1	Wiring Harness	1
16	44-873	Hour Meter	1



# 49-027 GUN & HOSE KIT

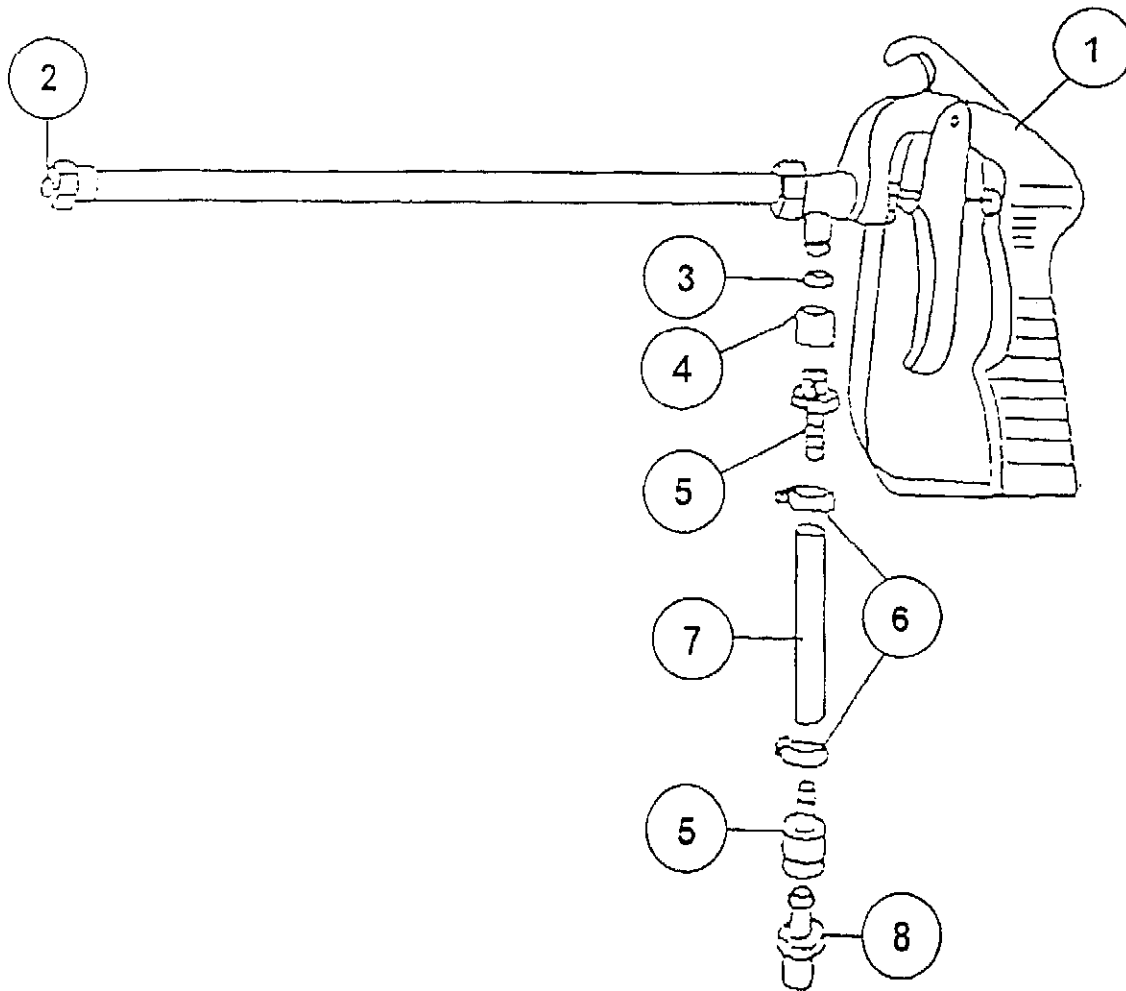

REF.#	PART#	DESCRIPTION	QTY.
1	4085	Spray Gun	1
2	709-053-6503	Nozzle Tip	1
3	19-725	Nylon Gasket	1
4	707-040	Adapter	1
5	19-658	1/4" Hose Barb	2
6	18-003	Hose Clamp	2
7	8800-12	1/4" Clear Hose (12')	1
8	44-008	Quick Coupler Plug	1

# BOOM DRAWING

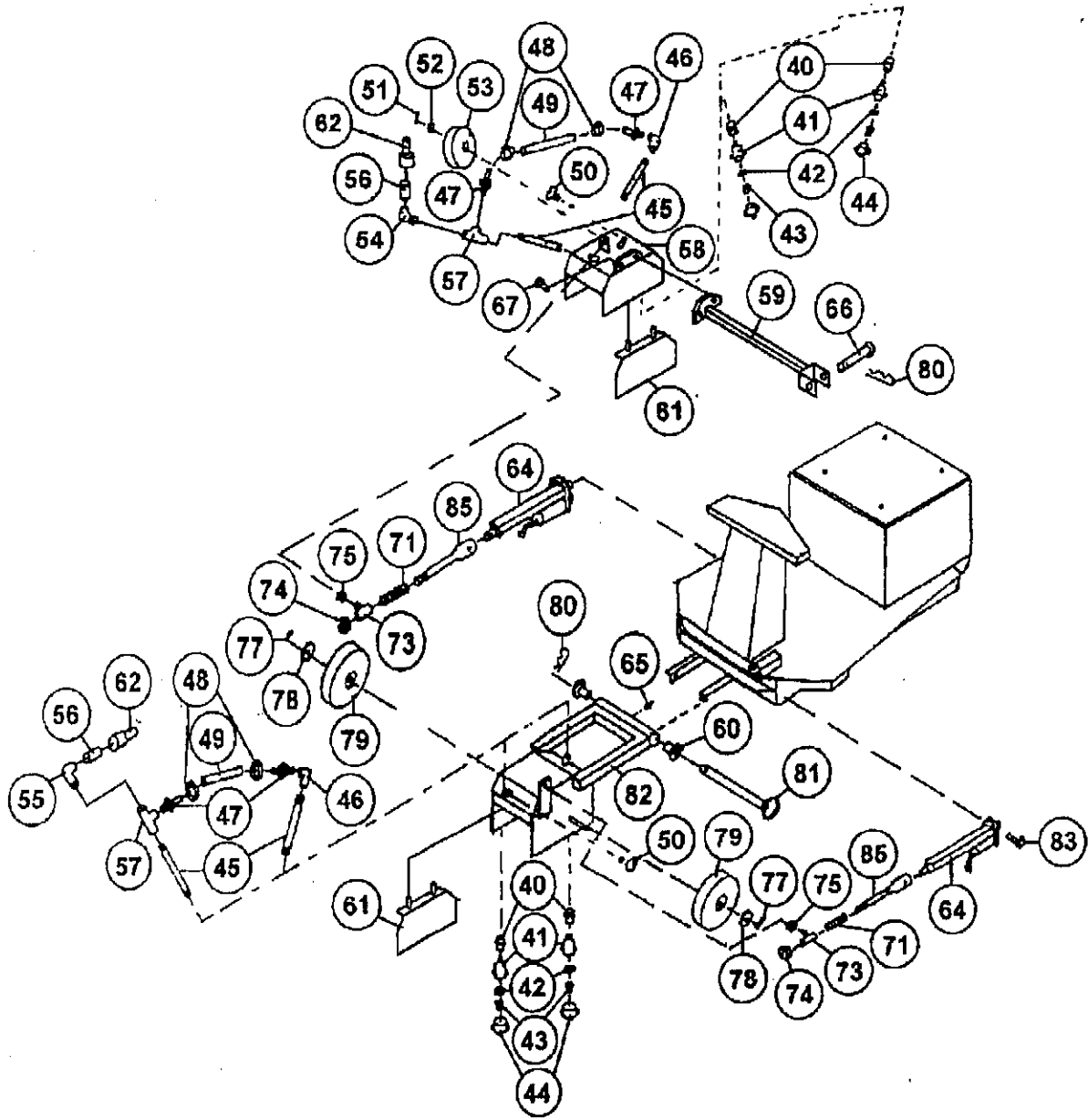

**49-028 BOOM PARTS LIST**

<b>REF.#</b>	<b>PART#</b>	<b>DESCRIPTION</b>	<b>QTY.</b>
40	500-314	¼" Coupling	4
41	19-697	Nozzle Body, Brass	4
42	19-698	Ball	4
43	709-053-8004EVS	Nozzle Tip	4
44	19-680	Brass Nozzle Cap	4
45	500-243	¼" x 4" Nipple Gal.	4
46	500-400	¼" Gal. Elbow	2
47	19-658	¼" Hose Barb	4
48	18-003	¼" Hose Clamp	4
49	638	¼" Black Hose	10"
50	400-060	5/16" x 1" Thumb Screw	4
51	41-168	1/8" x 1" Cotter Pin	1
52	40-128-1	½" ID x 7/8" OD Machine Bushing	3
53	49-017	8" Caster Wheel	1
54	18-007	¼" Brass 90° St Elbow	1
55	18-037	¼" 45° Brass St Elbow	1
56	18-011	¼" Close Nipple	2
57	18-012	¼" Brass Tee	2
58	44-727	Side Mount Boom	1
59	44-756	Side Boom Lift Arm	1
60	2110	Pivot Post Bearing	2
61	44-305-1	Boom Flapper	4
62	44-007	Socket	2
64	730-160	12 V. Actuator	2
65	709-382	¼" Grease Zerk	1
66	44-757	Side Boom Mounting Pin	1
71	19-674	Spring	2
73	41-255	Actuator Connecting Rod	2
74	400-112	½" Locknut	2
75	400-116	3/8" Locknut	2
77	40-168	1/8" x 1" Cotter Pin	2
78	40-128-1	½" ID x 7/8" OD Machine Bushing	6
79	49-017	8" Caster Wheel	2
80	2050	Snap Pin	2
81	41-243-1	Mounting Pin	1
82	41-310-1	Front Boom	1
85	41-254	Actuator Adjustment Rod	2
NI	19-699	Spring	4

## The Smithco Commercial Products Two-Year Limited Warranty

Smithco, Inc. (Smithco) warrants your 2007 or newer Smithco Commercial Product ("Product") purchased after January 1, 2007, to be free from defects in materials or workmanship for the period of time listed below. Where a warrantable condition exists, Smithco will repair the Product at no cost to you including diagnosis, labor (at the Smithco standard labor rate, subject to the Smithco flat rate schedule), and parts.

### Warranty Duration Is:

1. Two years, 1500 operational hours\* from the date of delivery to the original purchaser or three years from the date of original manufacturer of the product, whichever occurs first. (\*Products equipped with hour meter).
2. Products used in rental situations are covered for 90 days from date of delivery to original user/renter.

### Owner responsibilities:

As the Product owner, you are responsible for required maintenance and adjustments stated in your Owner's Manual. Failure to perform required maintenance and adjustments can be grounds for disallowing a warranty claim. You are particularly responsible to train all present and future operators of this product on the safe operation of this product at your location.

### Instructions for Obtaining Warranty Service:

You are responsible for notifying the Authorized Smithco Products Distributor from whom you purchased the Product as soon as you believe a warrantable condition exists and not later than 30 days from discovery of the condition.

If you need help locating an Authorized Smithco Distributor, or if you have questions regarding your warranty rights or responsibilities, you may contact us at:

Smithco Product Support Department  
Highway 55 @ Poplar St.  
Cameron, Wisconsin 54822  
Telephone: 715-458-4192 E-Mail: [ProductSupport@Smithco.com](mailto:ProductSupport@Smithco.com)

### Maintenance Parts:

Parts scheduled for replacement as required maintenance ("Maintenance Parts"), are warranted for the period of time up to the scheduled replacement time for that part.

### Items/Conditions Not Covered:

Not all product failures or malfunctions that occur during the warranty period are defects in materials or workmanship. The items/conditions listed below are not covered by this warranty.



Product failures which result from the use of non-Smithco replacement parts, or from installation and use of add-on, modified, or unapproved accessories are not covered.



Product failures which result from failure to perform required maintenance and/or adjustments are not covered.



Product failures that result from operating the Product in an abusive, negligent or reckless manner are not covered.



This warranty does not apply to parts subject to consumption through use, unless found to be defective. Examples of parts which are consumed, or used up during normal Product operation include, but are not limited to: blades, tines, teeth, scarifiers, rakes, plates, wear plates, castor wheels, tires, batteries, filters, belts, nozzles, etc.



This warranty does not apply to failures caused by outside influence. Items considered to be outside influence include, but are not limited to, weather, storage practices, contamination, use of unapproved coolants, lubricants, additives, or chemicals, etc.



This warranty does not apply to normal "wear and tear" items. Normal "Wear and Tear" includes, but is not limited to, damage to seats due to wear or abrasion, worn painted surfaces, scratched decals or windows, etc.



Smithco may require the return of failed parts or components in order determine the validity of any warranty claim.



Smithco will not be obligated to replace components of other manufacturers if inspection by the original component manufacturer indicates that failure was due to normal wear and tear, expected consumption through use or improper care or service.

#### **Other Legal Disclaimers:**

The above remedy for product defects through repair or replacement by an authorized Smithco distributor or dealer is the purchaser's sole remedy for any defect. This warranty gives you specific legal rights, and you may also have other rights which vary from state to state.

**THERE ARE NO OTHER EXPRESS WARRANTIES OTHER THAN THOSE SET FORTH ABOVE. ALL IMPLIED WARRANTIES OF MERCHANTABILITY AND FITNESS FOR USE ARE LIMITED TO THE DURATION OF THE LIMITED WARRANTIES CONTAINED HEREIN.**

Some States may not allow limitations on how long an implied warranty lasts, so the above limitation may not apply to you.

**THE SMITHCO COMPANY IS NOT LIABLE FOR INDIRECT, INCIDENTAL OR CONSEQUENTIAL DAMAGES IN CONNECTION WITH THE USE OF THE PRODUCT, INCLUDING ANY COST OR EXPENSE OF PROVIDING A SUBSTITUTE PRODUCT OR SERVICE DURING PERIODS OF MALFUNCTION OR NON-USE.**

Some states may not allow the exclusion of indirect, incidental or consequential damages, so the above exclusion may not apply to you.

**Smithco neither assumes, nor authorizes any person to assume for it, any other liability in connection with the sale or use of this product.**

**SMITHCO, INC.  
WANYE, PA 19087**

