



Parts Manual

TOURNAMENT ULTRA XXL GREENS ROLLER 70"

7000
SN: T8315

Revised July 2019

Product Support: 1020 Hawaii Rd; Humboldt, KS 66748
1-888-422-5173 wj@smithco.com

TABLE OF CONTENTS

TITLE	PAGE
Frame Drawing	1
Frame Parts List	2-3
Roller Housing Drawing	4
Roller Housing Parts List	5
Steering Drawing	6
Steering Parts List	7
Wiring Drawing & Parts List	8
Engine Drawing & Parts List	9
Wheel Motor Drawing	10
Wheel Motor Parts List	11
Hydraulic Plumbing Drawing	12
Hydraulic Plumbing Parts List	13
750-846 Pump Drawing	14
750-846 Pump Parts List	15
Pump Linkage Drawing	16
Pump Linkage Parts List	17
Performance Chart	18-19
750-341 Light Kit Parts List & Installation	20-21
7520 Trailer Drawing	22
7520 Trailer Parts List	23
Guide Rail & Roller Stop Installation	24
7525 Trailer Drawing	25
7525 Trailer Parts List	26
Trailer Springs	27
SMITHCO Warranty	28-29

7000 FRAME DRAWING

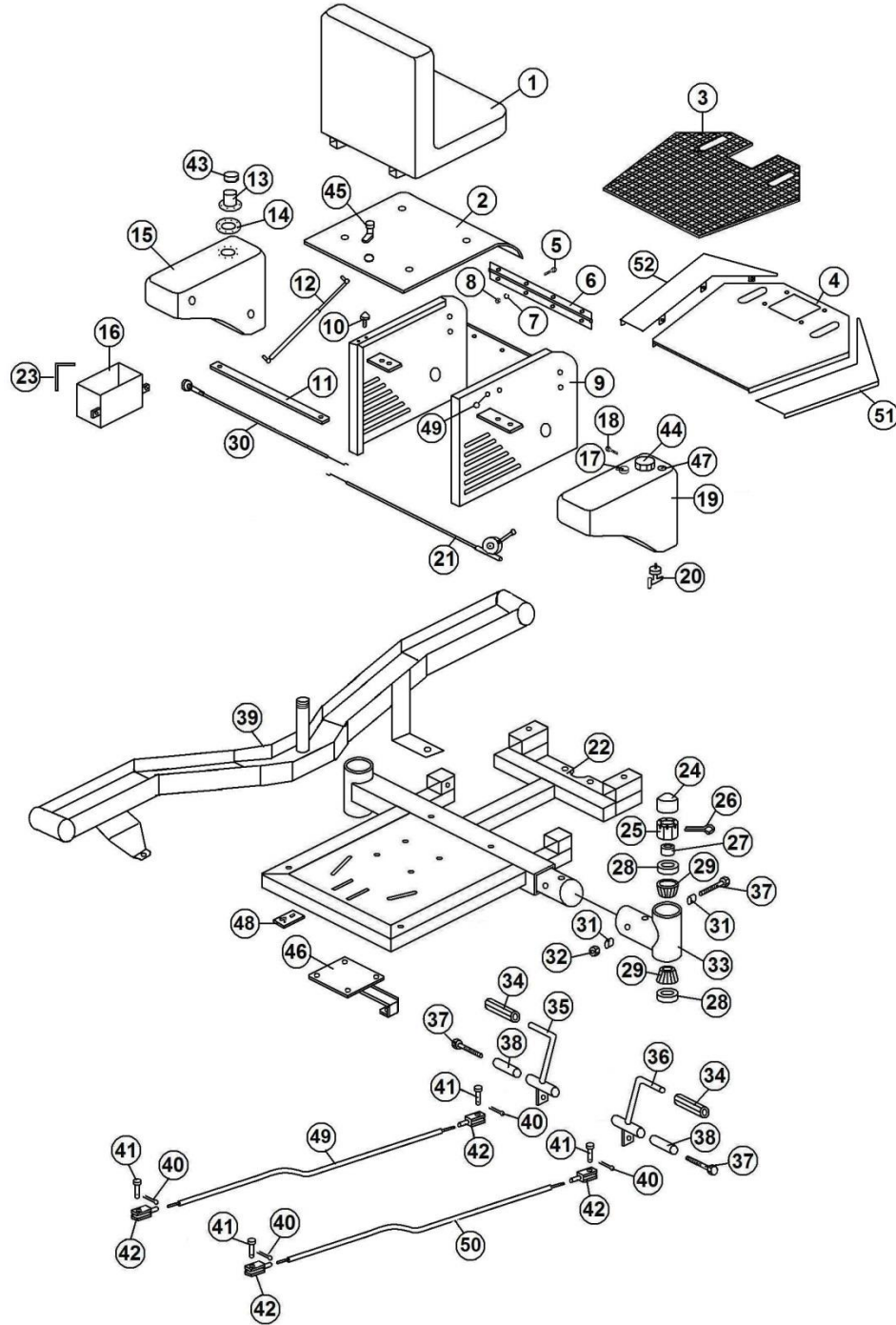

7000 FRAME PARTS LIST

REF#	PART#	DESCRIPTION	QTY.
1	832-123	Low-Back "Smithco" Seat	1
2	750-253-1	Seat Plate	1
3	750-278	Rubber Mat	1
4	750-241	Deck Plate	1
5	400-002	5/16" x 1" HHCS	10
6	750-254	Seat Plate Hinge	1
7	400-207	5/16" Lockwasher	10
8	400-102	5/16" – 18 Hex Nut	10
9	750-262	Engine Cover	1
10	41-143	Protective Bumper	2
11	750-290	Cover Brace	1
12	750-891	Gas Shock Assembly	1
13	750-293	Oil Tank Neck	1
14	750-292-1	Oil Cap Gasket	1
15	943-111	Oil Tank	1
16	750-402	Battery Box	1
17	943-110-4	Vent Valve	1
18	400-043	1/4" – 20 x 3/4" HHCS	10
19	943-110	Gas Tank	1
20	943-110-2	Gas Valve	1
21	750-715	Throttle Cable	1
22	750-570	Main Frame	1
23	750-977	Battery Hold Down Assembly	1
24	750-192	1 1/8" Poly Hex Nut & Cap	4
25	932-042	Thick Slotted Nut 1 1/4"	2
26	709-143	Cotter Pin 1/8" x 2"	2
27	932-024	Spacer	2
28	932-022	Seal	8
29	932-023	Bearing	8
30	943-126	Choke Cable	1
31	750-186	1/2" ID x 3/4" OD x 1/2" Spacer	2
32	400-112	1/2" – 13 Locknut 2-Way	1
33	750-166	Swivel Axle Bracket	1
34	943-127	Accelerator Pedal Pad	2
35	750-893	Left Foot Pedal	1
36	750-892	Right Foot Pedal	1
37	400-061-1	1/2" – 13 x 3 1/2" All Thread / Tap Bolt	2
38	10-007	Oilite Bushing	4
39	750-571	Left Roller Housing Frame	1
40	720-079	Cotter Pin 3/32 x 3/4"	4
41	720-078-1	5/16" x 1" Clevis Pin	4
42	11-101-1	Linkage Yoke	4
43	750-292	Oil Filler Breather	1
44	943-110-5	Gas Cap	1
45	843-172	Cover Latch	1

7000 FRAME PARTS LIST (Continued)

REF#	PART#	DESCRIPTION	QTY.
46	750-588	Power Steering Bracket	1
47	943-110-6	Gas Gauge	1
48	750-250	Speed Boss Bracket	1
49	750-005-1	Left Foot Rod Assembly	1
50	750-004-1	Right Foot Rod Assembly	1
51	750-591	Right Foot Guard (CE Only)	1
52	750-592	Left Foot Guard (CE Only)	1

7000 ROLLER HOUSING DRAWING

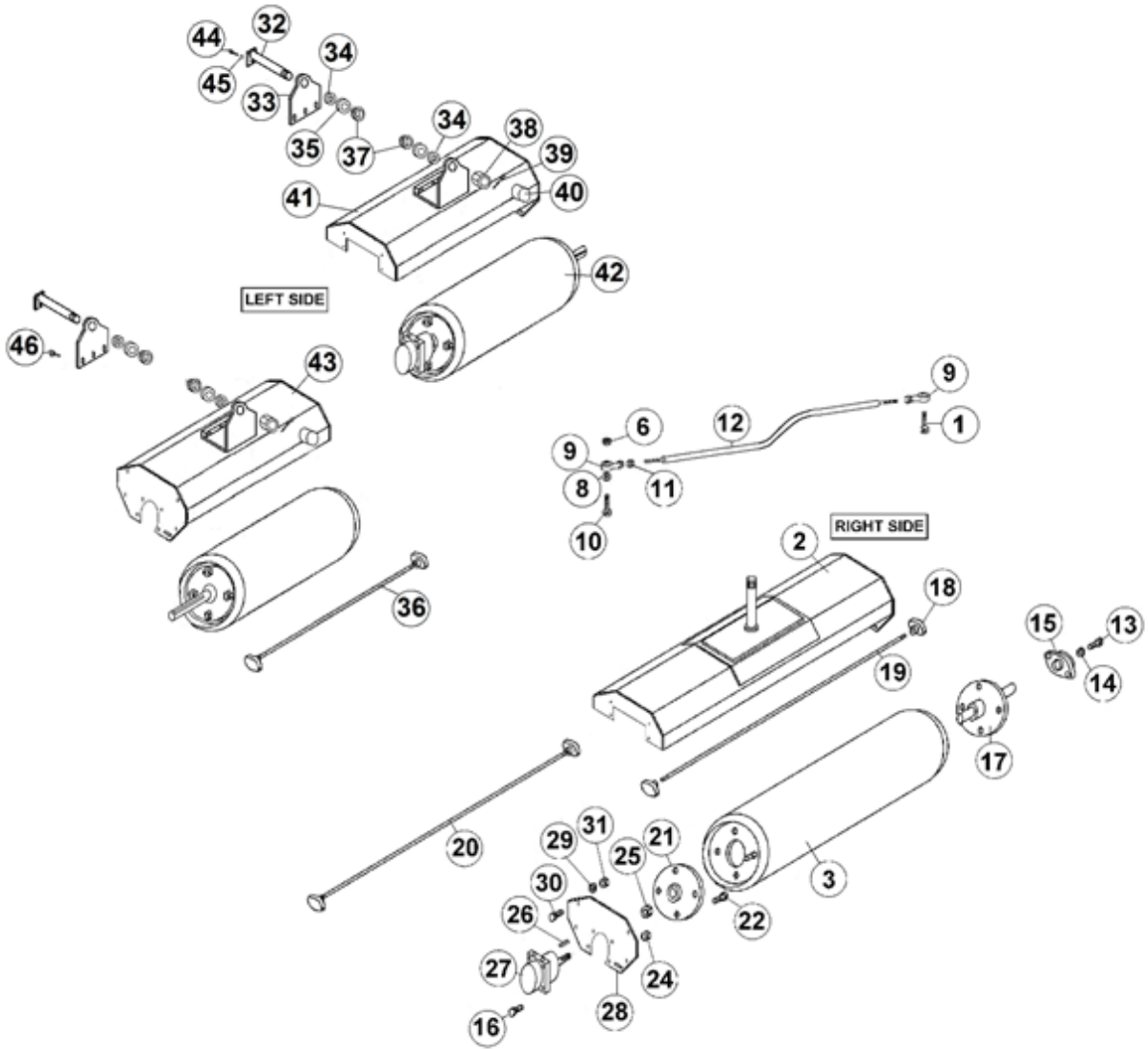

7000 ROLLER HOUSING PARTS LIST

REF#	PART#	DESCRIPTION	QTY.
1	400-099	½" x 1 ¾" Bolt	1
2	750-826	Right Roller Housing	1
3	750-821	Roller Cylinder	2
6	400-112	½" -13 Slotted Lock Nut	2
8	400-286	½" – 13 Hex Nut	2
9	713-806	Ball Joint	2
10	400-027	½" – 13 X 1 ½" HHCS	1
11	400-334	½" Flanged Lock Nut	2
12	750-578	Tie Rod	1
13	400-090	¾" – 16 x 1 ¼" HHCS	4
14	400-116	¾" Lock Nut	4
15	720-004	Flange Bearing	2
16	400-346	¾" Flange Bolt	8
17	750-220-2	Hub Shaft	2
18	750-210-2	Scraper Knob	6
19	750-210-1	Scraper Rod	1
20	750-210	Scraper Assembly	1
21	750-802	Hub 4 Bolt	3
22	1188	Lug Bolt	8
24	400-119	7/16" Lock Nut	8
25	750-801-1	Nut	2
26	740-023	3/16" x ¾" Woodruff Key	3
27	750-801	Wheel Motor	3
28	750-827	Bolted End Plate f/Housing	3
29	400-202	5/16" Flat Washer	8
30	400-014	¾" x 1" HHCS	8
31	400-116	¾" Lock Nut	8
32	750-572	Spindle Shaft	2
33	750-573	Spindle Shaft Plate	2
34	932-024	Spacer	6
35	932-022	Seal	4
36	750-577	Scraper Rod Assembly w/Knobs	2
37	932-023	Bearing	4
38	932-042	Thick Slotted Hex Nut 1 ¼" – 12	4
39	709-143-1	Cotter Pin 1/8" x 2 ½"	2
40	750-192	1 1/8" Poly Hex Nut & Bolt Cap	2
41	750-574	Roller Housing Left – Front	1
42	750-557	Roller Assembly	2
43	750-576	Roller Housing Left – Rear	1
44	400-014	¾" – 16 x 1" HHCS	2
45	400-209	¾" Lock Washer	2
46	400-345	½" x 1 ¼" Bolt	6

7000 STEERING DRAWING

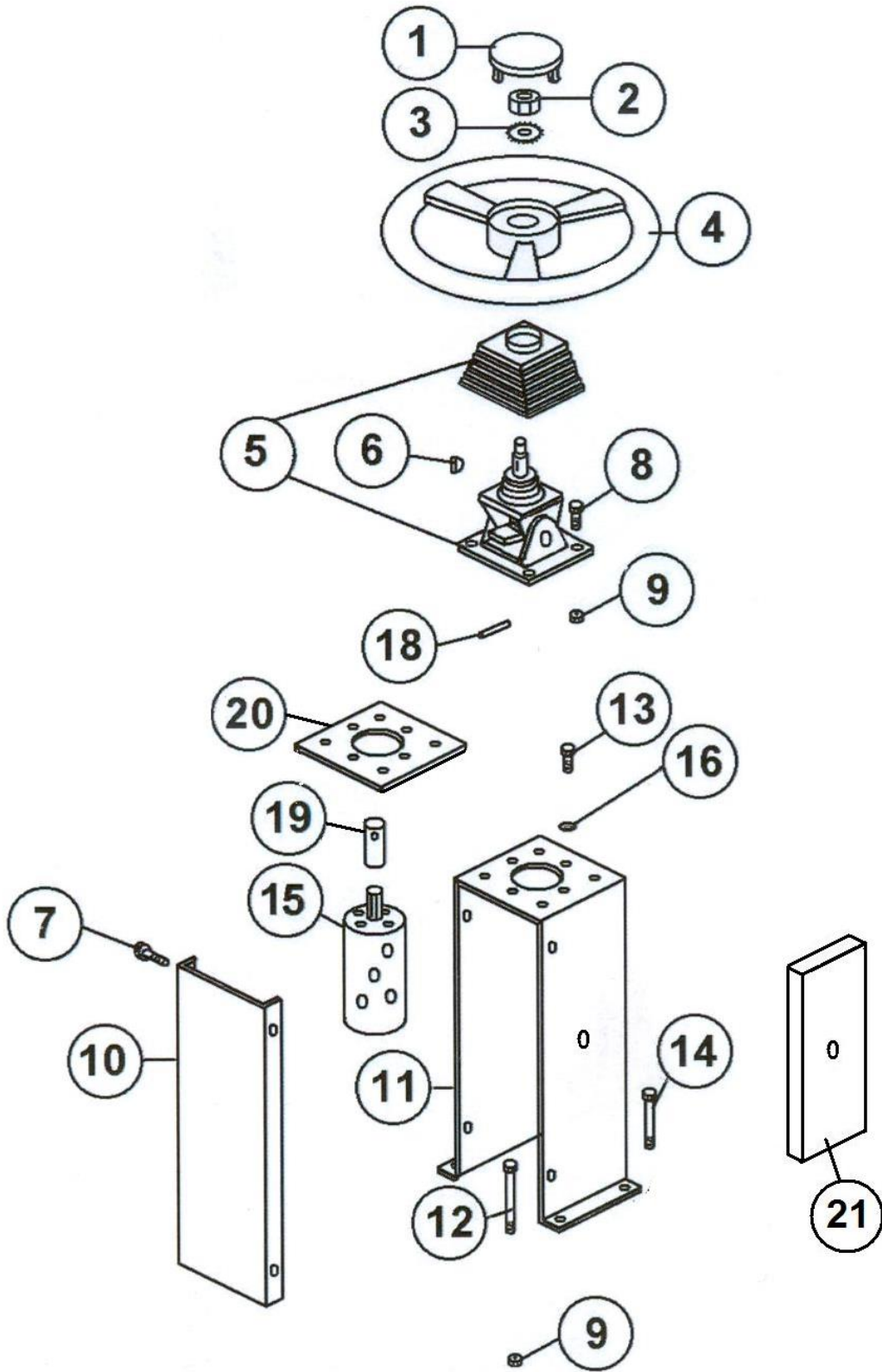

7000 STEERING PARTS LIST

REF#	PART#	DESCRIPTION	QTY.
1	730-046-2	Steering Wheel Cap	1
2	932-122	5/8" – 18 Hex Jam Nut	1
3	400-143	5/8" Lock Washer	1
4	730-046	Steering Wheel w/Cap	1
5	832-028	Tilt Steering Mechanism & Boot	1
6	740-023	3/16" x 3/4" Key	1
7	400-073-1	1/4" x 3/4" Screw	4
8	400-001	5/16" – 18 x 3/4" HHCS	4
9	400-281	5/16" Flanged Lock Nut	8
10	750-107	Steering Column Cover	1
11	750-106	Steering Column	1
12	400-339	5/16" – 18 x 7" HHCS	2
13	400-337	#6 x 3/4" Bolt	4
14	400-010	5/16" x 5" Bolt	2
15	750-804	Orbital	1
16	400-208	1/4" Lock Washer	4
18	832-031	Double Roll Pin	2
19	750-806	Stub Shaft	1
20	750-845	Orbital Pump Plate	1
21	750-185-1	Weight Plate	1

7000 WIRING DRAWING

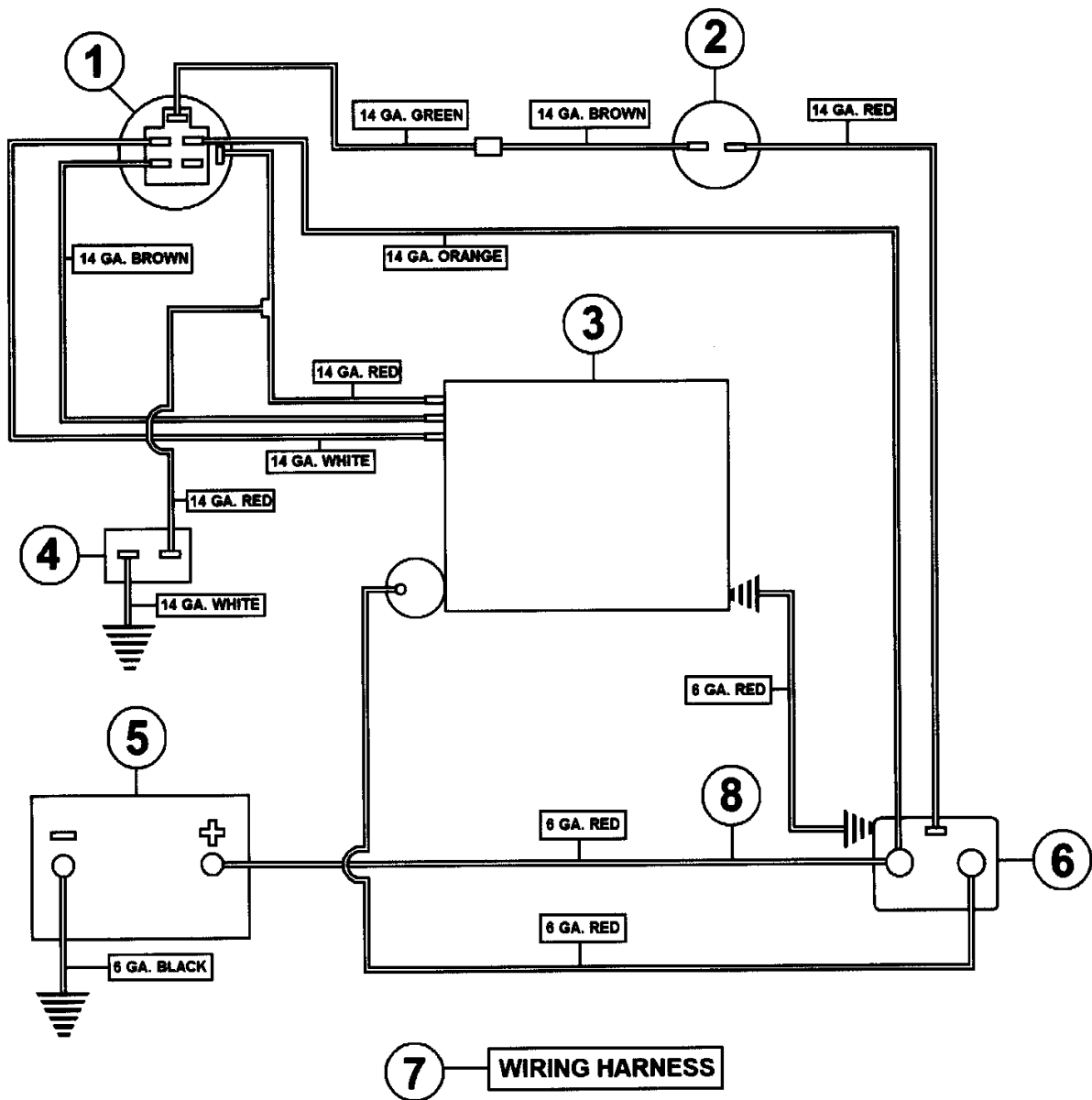

WIRING PARTS LIST

REF#	PART#	DESCRIPTION	QTY.
1	932-071	Key Switch	1
2	932-119-1	Safety Seat Switch	1
3	943-100	16 HP Vanguard Twin Engine	1
4	44-873	Hour Meter	1
5		Battery	1
6	932-072	Solenoid	1
7	750-265	Wiring Harness	1
8	750-401	Battery Wire 6GA Red 33"	1

7000 ENGINE DRAWING

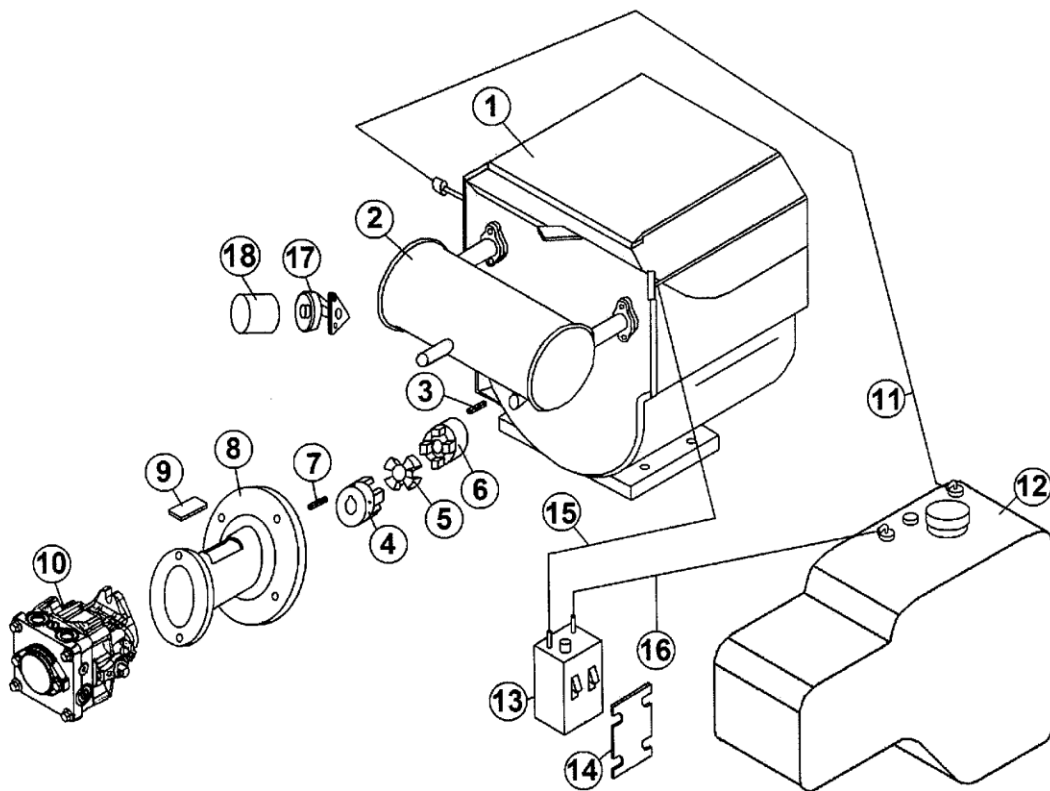

7000 ENGINE PARTS LIST

REF#	PART#	DESCRIPTION	QTY.
1	943-100	16 HP Engine (Model# 303447 Type 1131-E1)	1
2	943-115	Muffler	1
3	1517	¼" x 1" Key	1
4	750-851	Pump Hub	1
5	720-027	Element	1
6	41-147	Engine Coupling 1"	1
7	750-201	#5 x 1" Key	1
8	750-255	Bell Housing	1
9	750-127-1	Bell Housing Cover	1
10	750-846	16cc w/Aux Charge Pump	1
11	638	¼" Gas Hose 35"	1
12	943-110	Gas Tank	1
13	943-241	Carbon Canister	1
14	943-240	Carbon Canister Mount	1
15	638	¼" Gas Hose 40"	1
16	638	¼" Gas Hose 17"	1
17	943-159	Oil Filter Adapter	1
18	943-104	Oil Filter	1

750-801 WHEEL MOTOR DRAWING

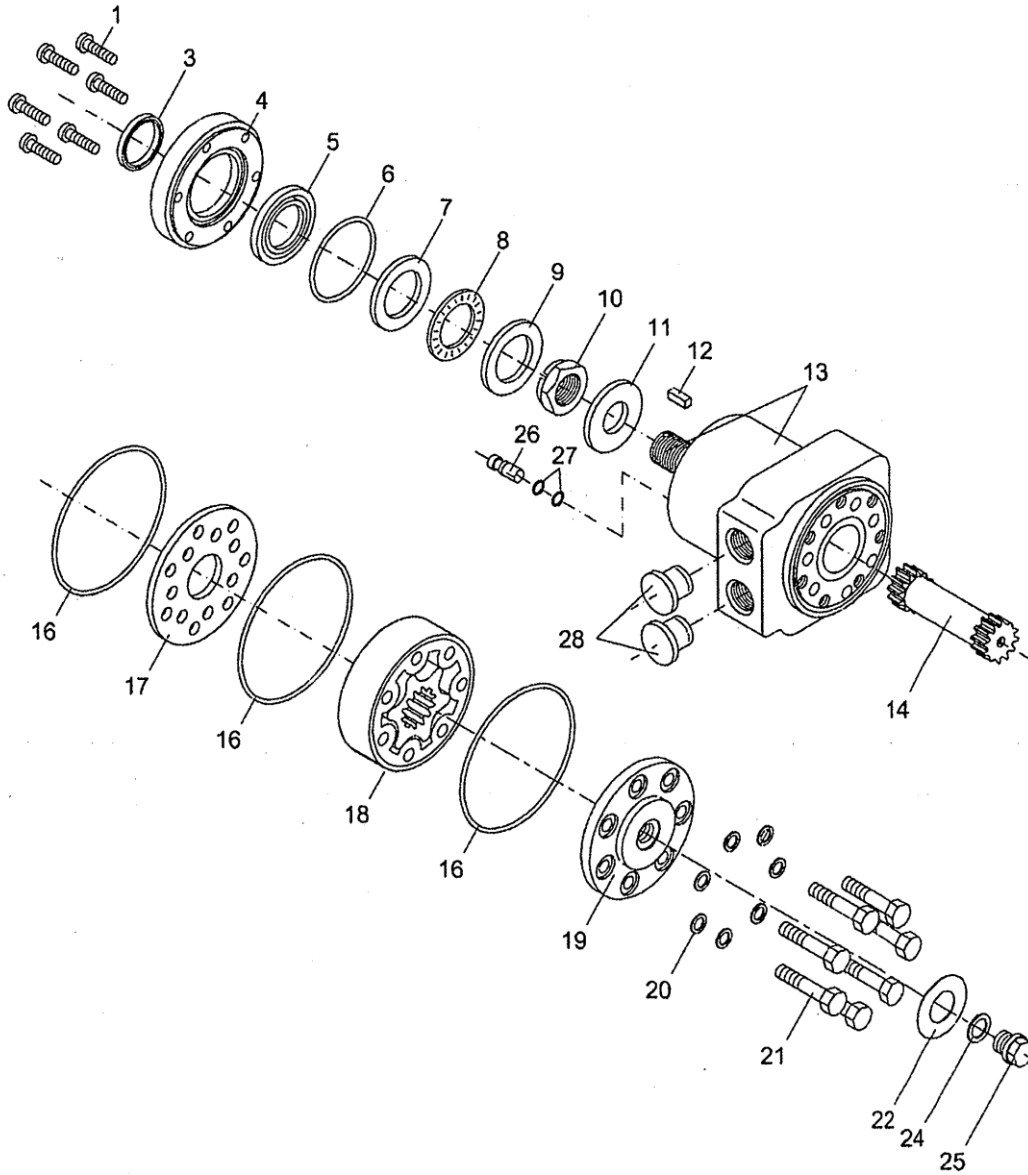

151-1379.10

750-801 WHEEL MOTOR PARTS LIST

REF#	PART#	DESCRIPTION	QTY.
1	750-801-6	Screw	6
3	750-801-5	Dust Seal Ring	1
4	750-801-7	Spigot Flange	1
5	750-801-5	Shaft Seal	1
6	750-801-5	O-Ring	1
7	750-801-8	Bearing Race	1
8	750-801-9	Axle Needle Bearing	1
9	750-801-10	Bearing Race	1
10	750-801-11	Castellated Nut	1
11	750-801-12	Washer	1
12	740-023	Woodruff Key, 3/16" x 3/4"	1
14	750-801-14	Cardan Shaft	1
16	750-801-5	O-Ring	3
17	750-801-15	Distributor Plate	1
18	750-801-16	Gear Wheel Set	1
19	750-801-17	End Cover	1
20	750-801-18	Washer	7
21	750-801-19	Screw	7
24	750-801-20	Washer	1
26	750-801-21	Check Valve	2

Note: Reference #'s 3, 5, 6 & 16 are part of the 750-801-5 Seal Kit

HYDRAULIC PLUMBING DRAWING

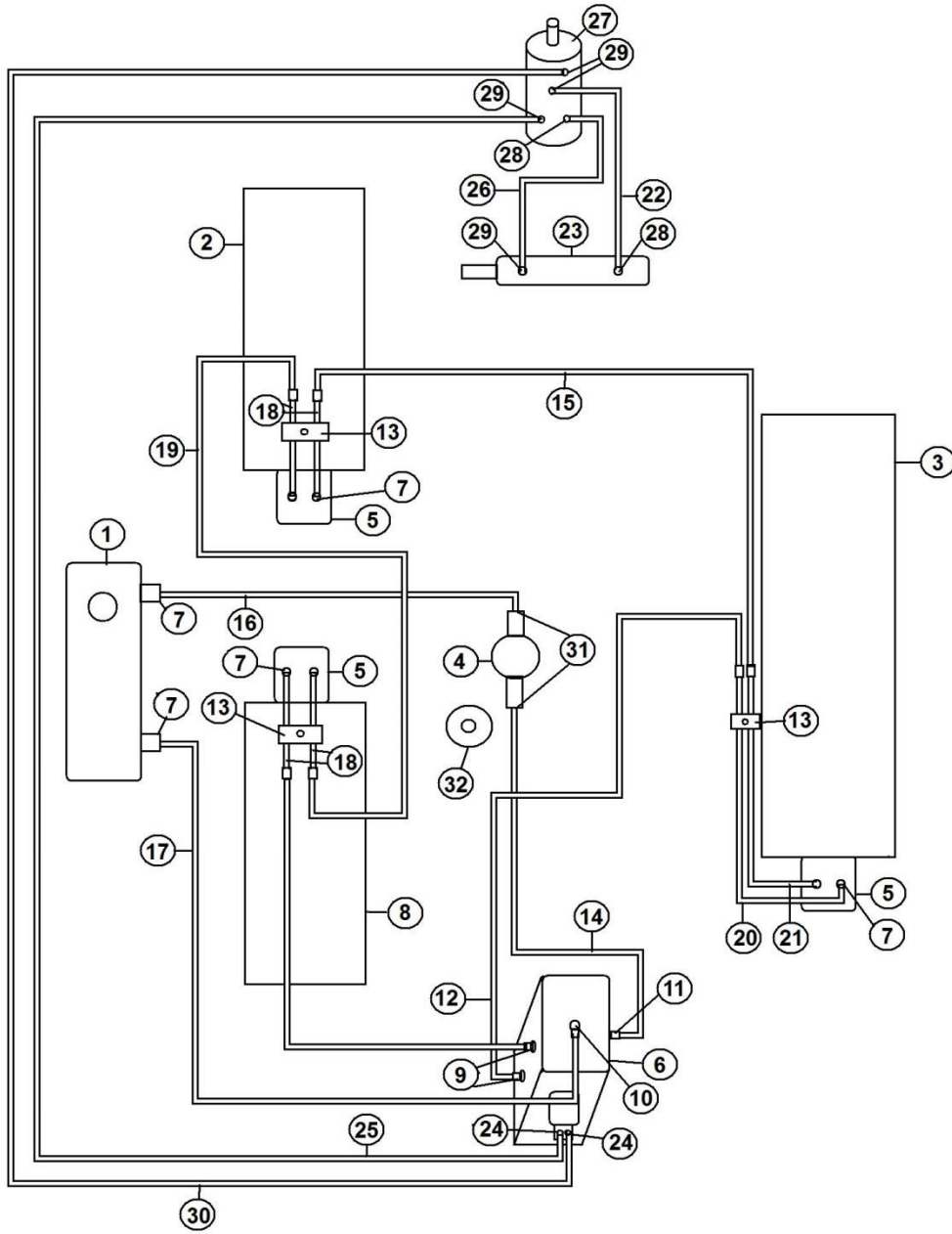

HYDRAULIC PLUMBING PARTS LIST

REF#	PART#	DESCRIPTION	QTY.
1	943-111	Oil Tank	1
2	750-574	Roller Housing Left Front	1
3	750-826	Right Roller Housing	1
4	750-302	Filter Head	1
5	750-801	Wheel Motor	3
6	750-846	16 cc w/Aux Charge Pump	1
7	750-326	Wheel Motor Fitting	8
8	750-576	Roller Housing Left Rear	1
9	750-322	Pump Fitting 45°	2
10	750-324	8 – 6 90° Pump Fitting Top	1
11	750-848	8 – 8 Side Pump Fitting	1
12	750-511	Hyd Hose 62"	1
13	750-502	Hard Line Clamp	3
14	750-310	Hydraulic Hose – Pump to Filter 15"	1
15	750-562	Hydraulic Hose w/ 45° 66"	1
16	750-306	Hydraulic Hose – Filter to Tank 7 ¼"	1
17	750-305	Hydraulic Hose – Oil Tank to Pump 10 ¼"	1
18	750-561	Short Hard Line	4
19	750-563	Hydraulic Hose 78"	1
20	750-506	Hard Line Long Right Side	1
21	750-507	Hard Line Short Right Side	1
22	750-833	Hydraulic Hose 36"	1
23	943-504	Hydraulic Cylinder	1
24	750-834	Hydraulic Fitting ¼" 45°	2
25	750-835	Hydraulic Hose 65"	1
26	750-836	Hydraulic Hose 33 ½"	1
27	750-804	Power Steering Pump	1
28	750-837	Hydraulic Fitting 90° Flare	2
29	750-838	Hydraulic Fitting Str. Flare	4
30	750-835	Hydraulic Hose 65"	1
31	750-825	8 – 12 Filter Head Fitting	2
32	750-300	Oil Filter	1

750-846 PUMP DRAWING

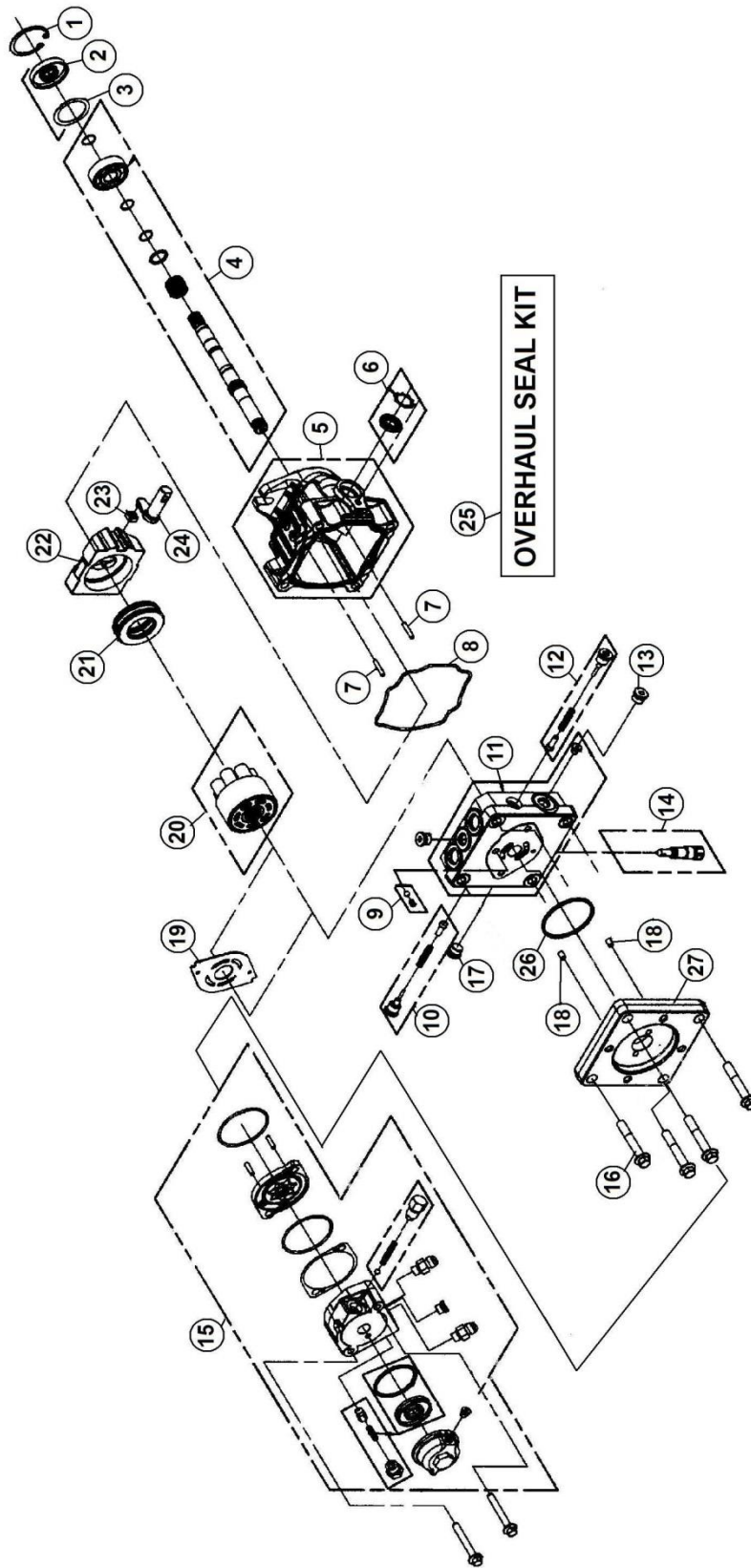

750-846 PUMP PARTS LIST

REF#	PART#	DESCRIPTION	QTY.
1	750-847-3	Retaining Ring	1
2	750-847-4	Lip Seal	1
3	750-847-5	Spacer	1
4	750-847-6	Shaft Kit	1
5	750-847-7	Housing	1
6	750-847-8	Trunnion Seal Kit	1
7	750-228-15	Pin	2
8	750-847-9	O-Ring	1
9	750-847-10	Charge Relief	1
10	750-847-11	Shock Valve Kit	1
11	750-847-12	End Cap	1
12	750-847-11	Shock Valve Kit	1
13	750-847-13	Plug	1
14	750-228-7	Bypass Kit	1
15	750-846-1	Charge Pump	1
16	750-846-2	Screw	4
17	750-847-13	Plug	1
18	758-846-3	Screw	2
19	750-847-17	Valve Plate	1
20	750-847-18	Cylinder Block	1
21	750-847-19	Thrust Bearing	1
22	750-847-20	Swash Plate	1
23	750-128-38	Slot Guide	1
24	750-847-21	Trunnion Arm	1
25	750-849	Seal Kit	1
26	750-846-4	O-Ring	1
27	750-846-5	Plate	1

PUMP LINKAGE DRAWING

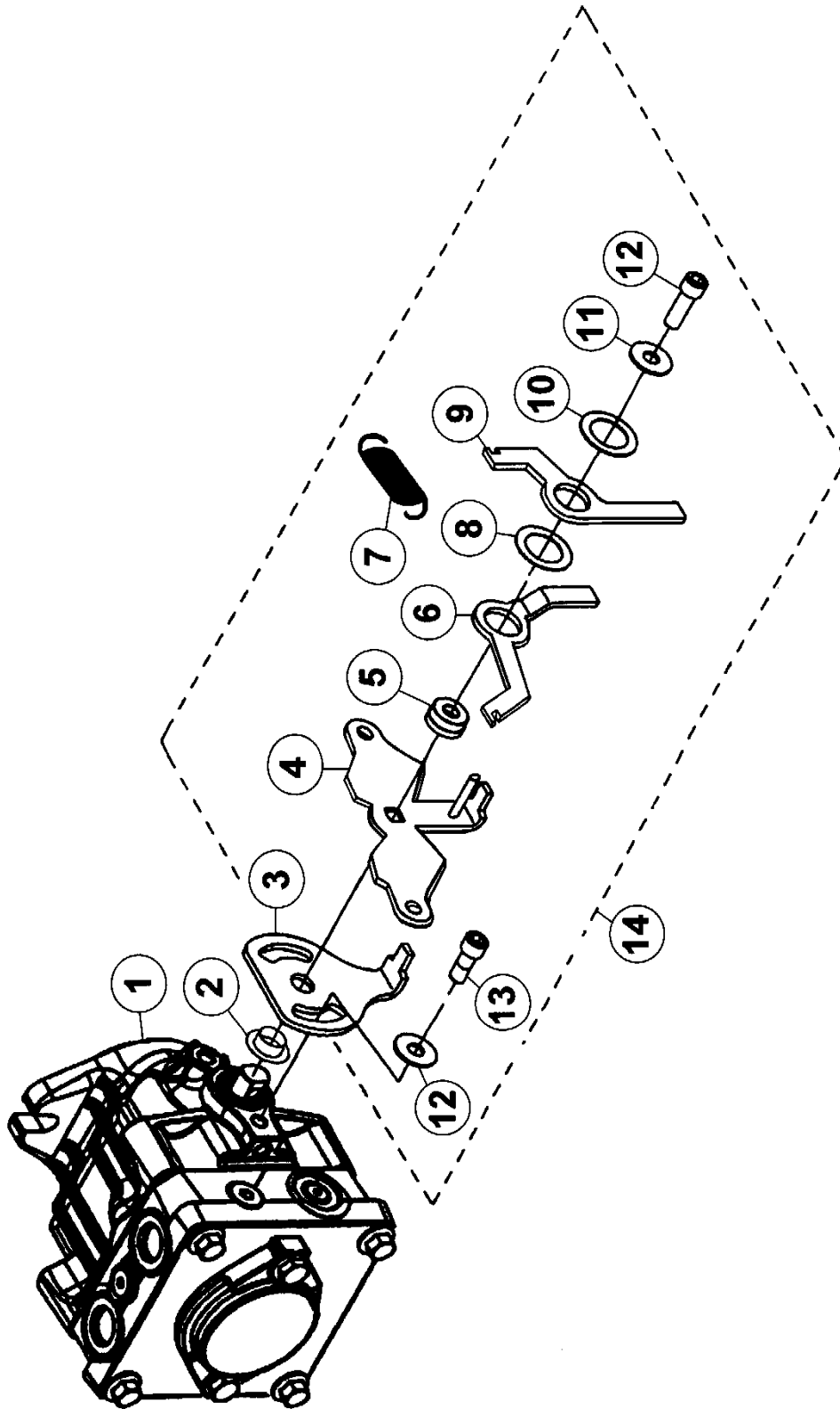

PUMP LINKAGE PARTS LIST

REF.#	PART#	DESCRIPTION	QTY.
1	750-846	16cc w/Aux Charge Pump	1
2	750-228-30	Bushing	1
3	750-343-1	Shift Lever Top (New)	1
3	750-343	Shift Lever Top (Old)	1
4	750-344-1	Shift Lever Bottom (Sq. Hole .470)	1
4	750-344	Shift Lever Bottom (Sq. Hole .350)	1
5	750-228-31	Bushing	1
6	750-345	Shift lever Right	1
7	750-229-1	Spring	1
8	750-228-32	Washer	1
9	750-346	Shift Lever Left	1
10	750-228-33	Washer	1
11	750-228-34	5/16" Flat Washer	2
12	750-228-35	Allen Head Bolt	1
13	750-228-36	Allen Head Bolt	1
14	750-228-37	Parts Kit	1

PERFORMANCE CHART

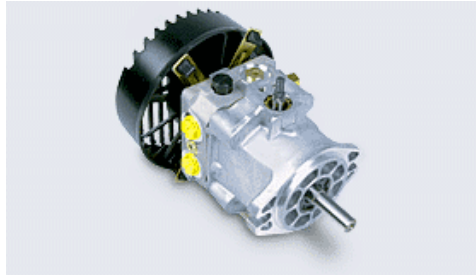

Product Type		PC	PG	PJ	PR	PW
Displacement	in ³ /rev [cc/rev]	0.37 [6.1]	0.62 [10.2]	0.73 [12]	0.97 [16]	1.33 [21.8]
Input Speed						
Maximum Unloaded	rpm	3600	3600	3600	3600	3600
Minimum Loaded	rpm	1800	1800	1800	1800	1800
System Operating Pressure						
Continuous	psi [bar]	750 [51]	1000 [70]	1000 [70]	1250 [86]	1250 [86]
Intermittent	psi [bar]	1750 [120]	2100 [145]	2100 [145]	2500 [172]	2500 [172]
Peak	psi [bar]	2500 [172]	3500 [240]	3500 [240]	3750 [260]	3750 [260]
Pump Performance						
@ 2400 rpm/1000 psi	gpm [l/min]	3.6 [13.6]	6.1 [23.1]	7.1 [26.8]	9.6 [36.3]	13.1 [49.6]
@ 3000 rpm/1000 psi	gpm [l/min]	4.5 [17.0]	7.6 [28.8]	8.9 [33.6]	12 [45.4]	16.4 [62.1]
@ 3600 rpm/1000 psi	gpm [l/min]	5.4 [20.4]	9.2 [34.8]	10.8 [40.8]	14.4 [54.5]	19.6 [74.2]
Case Pressure						
Maximum @ Cold Start	psi [bar]	10 [0.7]	10 [0.7]	10 [0.7]	25 [1.7]	25 [1.7]
Continuous - Max.	psi [bar]	4 [0.3]	4 [0.3]	4 [0.3]	10 [0.7]	10 [0.7]
Inlet Vacuum						
Maximum Continuous Inches Mercury		4	4	4	4	4
Charge Pump Displacement(s)	in ³ /rev [cc/rev]	.13 [2.1]	0.11/0.13 [1.9/2.1]	0.19 [3.2]	0.13/0.19 [2.1/3.2]	0.13/0.19 [2.1/3.2]
Auxiliary Pump Displacement	in ³ /rev [cc/rev]	0.19 [3.2]	0.19 [3.2]	0.19 [3.2]	0.19 [3.2]	0.19 [3.2]
Auxiliary Pump Relief Setting	psi [bar]	650 [45]	650 [45]	650 [45]	650 [45]	650 [45]
Auxiliary Pump Performance						
@3200 rpm, 500 psi, 70 SUS [13 Cst] oil, & 180°F	gpm [l/min]	1.8 - 2.0 [6.8 - 7.6]	1.8 - 2.0 [6.8 - 7.6]	1.8 - 2.0 [6.8 - 7.6]	1.8 - 2.0 [6.8 - 7.6]	1.8 - 2.0 [6.8 - 7.6]

**Control Torque Required
to Stroke Pump**
[Approximate - 20° External Stroke Angle]

	lb-in / 1000 psi [N-m / 70 bar]	75 [8.5]	85 [9.6]	85 [9.6]	95 [10.7]	105 [11.9]
	lb-in / 500 psi [N-m / 35 bar]	55 [6.2]	60 [6.8]	60 [6.8]	75 [8.5]	85 [9.6]
Pump Oil Temperature						
Maximum Intermittent (hottest point)	°F [°C]	230 [110]	230 [110]	230 [110]	230 [110]	230 [110]
Normal Operating Range	°F [°C]	-10 to 200 [-23 to 93]	-10 to 200 [-23 to 93]	-10 to 200 [-23 to 93]	-10 to 200 [-23 to 93]	-10 to 200 [-23 to 93]
Fluid Viscosity Limits @ 230°F [110°C]						
Optimum	SUS[cSt]	70 [13]	70 [13]	70 [13]	70 [13]	70 [13]
Minimum	SUS[cSt]	55 [9]	55 [9]	55 [9]	55 [9]	55 [9]
Weight of Unit						
	lbs [kg]	7 [3.2]	8 [3.6]	12.65 [5.7]	12 [5.4]	14 [6.3]
Inlet Filtration Requirement						
Nominal	micron	25	25	25	25	25

750-341 LIGHT KIT (Optional Accessory)

PART#	DESCRIPTION	QTY.
750-341-2	Wiring Harness	1
750-341-4	Switch Tab	1
750-341-3	Light Brackets	2
750-555-1	Light Bulbs	2
W095	Bullet Terminal (Included in wiring harness)	4
2070	Ignition Switch (Included in wiring harness)	1
709-255-1	Boot (Included in wiring harness)	1
	Zip Ties	4
	Loom	8"

LIGHT KIT INSTALLATION

1. Bolt the light brackets under the gas and oil tanks.

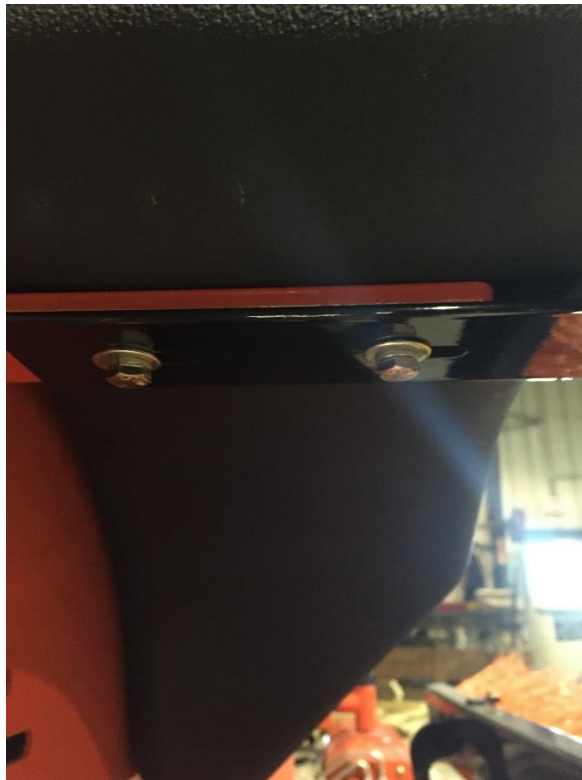

2. Bolt the lights to the light brackets. Bolt switch tab under the light over the battery for the toggle switch.
3. Connect wiring to lights. Wiring can run in back of the machine at the top. Zip tie the wiring to the bar at the back of the machine. The toggle switch goes to the left of the machine. Put the toggle switch in the switch tab.

4. Slip the excess loom over the wires on the right light. Use the 8" loom to cover wires on the left light.



5. Fasten the fuse to the positive on the battery and black to the negative on the battery.



7520 TRAILER DRAWING

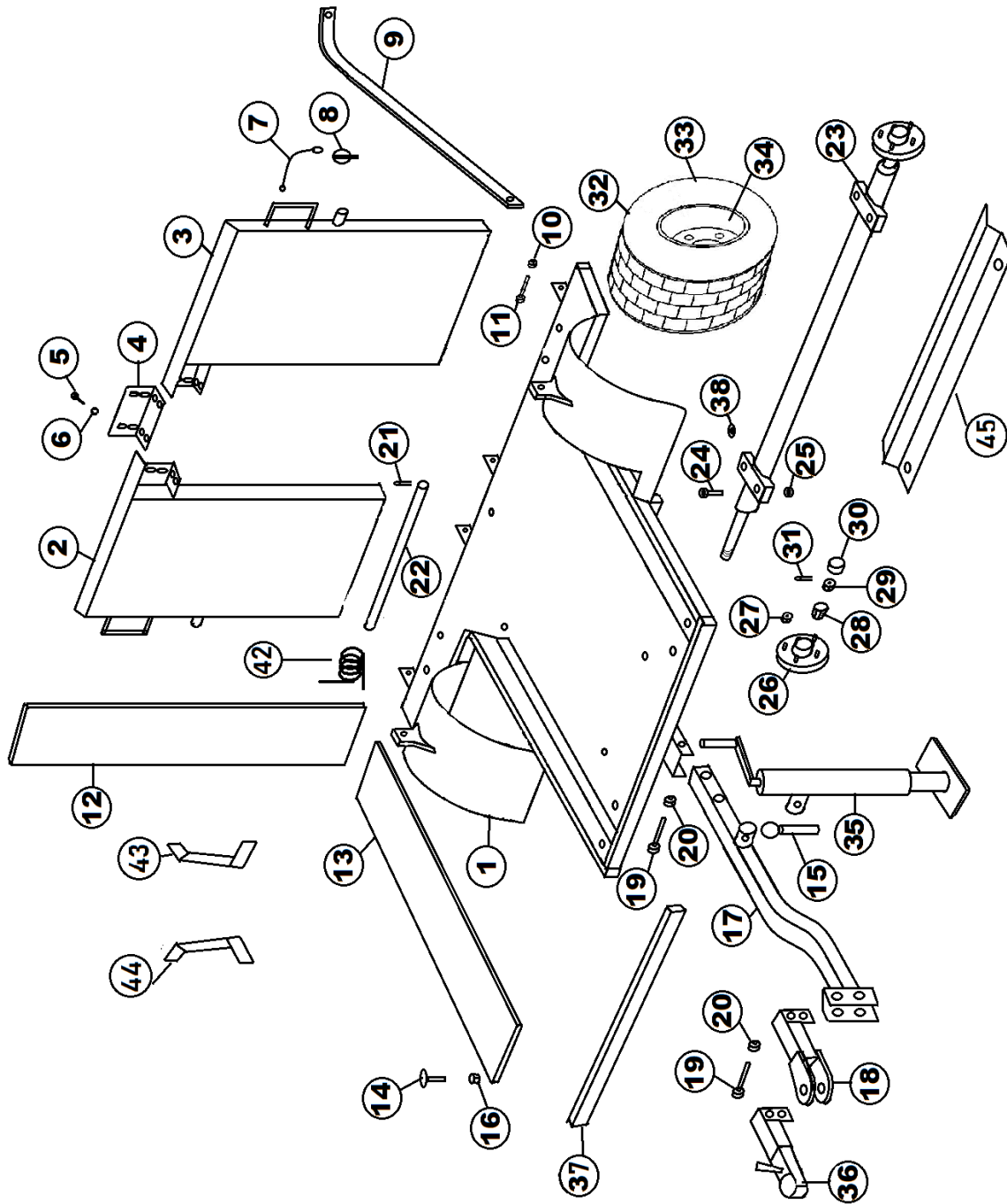

7520 TRAILER PARTS LIST

REF#	PART#	DESCRIPTION	QTY.
1	750-430	Trailer Bed	1
2	750-432	Right Side Ramp	1
3	750-431	Left Side Ramp	1
4	750-433	Ramp Plate	1
5	400-321	1/4" X 3/4" X 20 Truss Head Bolt	8
6	400-342	1/4" Flanged Locknut	8
7	750-422	3/64 x 6 Lanyard	2
8	750-421	Snap Pin 3/16 x 1 1/4"	2
9	750-437	Ramp Latch	2
10	400-112	1/2" - 13 Locknut	2
11	400-027	1/2" - 13 x 1 1/2" HHCS	2
12	750-164-7	Rubber Matting f/7520 Ramp 55" x 7"	4
13	750-438	Rubber Matting f/Bed 47" x 7"	2
14	400-255	Elevator Bolt	12
15	750-961-1	Jack Pin	1
16	400-281	5/16" Flanged Locknut	12
17	750-434	Drawbar	1
18	750-435	Drawbar Hitch	1
19	400-061	1/2" - 13 x 3 1/2" HHCS	4
20	400-112	1/2" - 13 Locknut	4
21	40-168	Cotter Pin 1/8 x 1"	4
22	750-436	Ramp Pin	2
23	750-960	Axle	1
24	400-015	3/8" - 16 x 1 1/2" HHCS	4
25	400-116	3/8" Locknut	4
26	2027-1	Hub Only	2
27	1187	Lug Nut	8
28	2028-1	Bearing	4
29	709-126	Spindle Nut	2
30	2024	Dust Cap	2
31	720-043	Cotter Pin	2
32	750-967	Wheel & Tire	2
33	750-967-1	Tire	2
34	2026	Wheel	2
35	750-961	Jackstand	1
36	750-435-1	Ball Hitch	1
37	750-440	Roller Stop	1
38	400-202	5/16" Flat Washer	8
39	400-014	3/8" - 16 x 1" HHCS	2
40	400-202	5/16" Flat Washer	12
41	400-116	3/8" Locknut	2
42	750-444	Spring	8
43	750-976	Left Guide	1
44	750-975	Right Guide	1
45	750-406-1	Roller Stop	1

7520 ROLLER GUIDE INSTALLATION



ROLLER STOP INSTALLATION



7525 TRAILER DRAWING F/7000 ROLLER

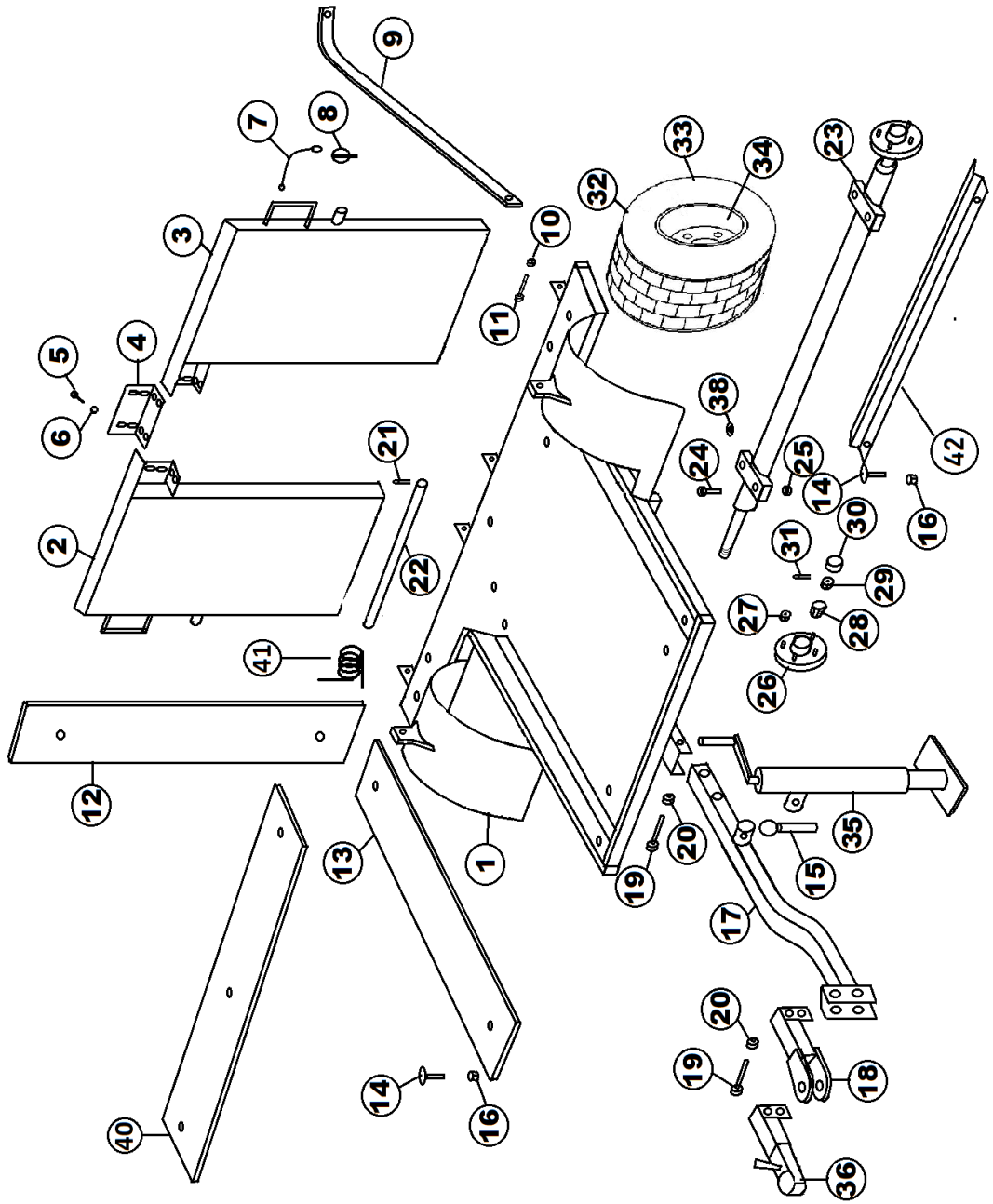

7525 TRAILER PARTS LIST F/7000 ROLLER

REF#	PART#	DESCRIPTION	QTY.
1	750-430	Trailer Bed	1
2	750-432	Right Side Ramp	1
3	750-431	Left Side Ramp	1
4	750-433	Ramp Plate	1
5	400-321	1/4" X 3/4" X 20 Truss Head Bolt	8
6	400-342	1/4" Flanged Locknut	8
7	750-422	3/64 x 6 Lanyard	2
8	750-421	Snap Pin 3/16 x 1 1/4"	2
9	750-441	Ramp Latch	2
10	400-112	1/2" - 13 Locknut	2
11	400-027	1/2" - 13 x 1 1/2" HHCS	2
12	750-439	Rubber Matting f/7525 Ramp 55" x 18"	2
13	750-438	Rubber Matting f/Bed 47" x 7"	2
14	400-255	Elevator Bolt	7
15	750-961-1	Jack Pin	1
16	400-281	5/16" Flanged Locknut	12
17	750-434	Drawbar	1
18	750-435	Drawbar Hitch	1
19	400-061	1/2" - 13 x 3 1/2" HHCS	4
20	400-112	1/2" - 13 Locknut	4
21	40-168	Cotter Pin 1/8 x 1"	4
22	750-436	Ramp Pin	2
23	750-960	Axle	1
24	400-015	3/8" - 16 x 1 1/2" HHCS	4
25	400-116	3/8" Locknut	4
26	2027-1	Hub Only	2
27	1187	Lug Nut	8
28	2028-1	Bearing	4
29	709-126	Spindle Nut	2
30	2024	Dust Cap	2
31	720-043	Cotter Pin	2
32	750-967	Wheel & Tire	2
33	750-967-1	Tire	2
34	2026	Wheel	2
35	750-961	Jackstand	1
36	750-435-1	Ball Hitch	1
38	400-202	5/16" Flat Washer	10
40	750-164-8	Rubber Matting f/Bed 63" x 7"	1
41	750-444	Spring	8
42	750-406-1	Roller Stop	1
*	400-207	Lock Washer 5/16"	
*	400-102	5/16" Nut	

*Part of bolt bag

TRAILER SPRING PLACEMENT



The Smithco Commercial Products Two-Year Limited Warranty

Smithco, Inc. (Smithco) warrants your 2016 or newer Smithco Commercial Product (“Product”) purchased after October 1, 2016 to be free from defects in materials or workmanship for the period of time listed below. Where a warrantable condition exists, Smithco will repair the Product at no cost to you including diagnosis, labor (at the Smithco standard labor rate, subject to the Smithco flat rate schedule), and parts.

Warranty Duration Is:

1. **Two years, 1500 operational hours* from the date of delivery to the original purchaser or five years from the date of original manufacturer of the product, whichever occurs first. (*Products equipped with hour meter).**
2. **Products used in rental situations are covered for 90 days from date of delivery to original user/renter.**

Owner responsibilities:

As the Product owner, you are responsible for required maintenance and adjustments stated in your Owner’s Manual. Failure to perform required maintenance and adjustments can be grounds for disallowing a warranty claim. **You are particularly responsible to train all present and future operators of this product on the safe operation of this product at your location.**

Instructions for Obtaining Warranty Service:

You are responsible for notifying the Authorized Smithco Products Distributor from whom you purchased the Product as soon as you believe a warrantable condition exists and not later than 30 days from discovery of the condition.

If you need help locating an Authorized Smithco Distributor, or if you have questions regarding your warranty rights or responsibilities, you may contact us at:

Smithco Product Support Department
Highway SS @ Poplar St.
Cameron, Wisconsin 54822
Telephone: 715-458-4192 E-Mail: ProductSupport@Smithco.com

Maintenance Parts:

Parts scheduled for replacement as required maintenance (“Maintenance Parts”), are warranted for the period of time up to the scheduled replacement time for that part.

Items/Conditions Not Covered:

Not all product failures or malfunctions that occur during the warranty period are defects in materials or workmanship. The items/conditions listed below are not covered by this warranty.



Product failures which result from the use of non-Smithco replacement parts, or from installation and use of add-on, modified, or unapproved accessories are not covered.



Product failures which result from failure to perform required maintenance and/or adjustments are not covered.



Product failures that result from operating the Product in an abusive, negligent or reckless manner are not covered.



This warranty does not apply to parts subject to consumption through use, unless found to be defective. Examples of parts which are consumed, or used up during normal Product operation include, but are not limited to: blades, tines, teeth, scarifiers, rakes, plates, wear plates, castor wheels, tires, batteries, filters, belts, nozzles, etc.



This warranty does not apply to failures caused by outside influence. Items considered to be outside influence include, but are not limited to, weather, storage practices, contamination, use of unapproved coolants, lubricants, additives, or chemicals, etc.



This warranty does not apply to normal "wear and tear" items. Normal "Wear and Tear" includes, but is not limited to, damage to seats due to wear or abrasion, worn painted surfaces, scratched decals or windows, etc.



Smithco may require the return of failed parts or components in order determine the validity of any warranty claim.



Smithco will not be obligated to replace components of other manufacturers if inspection by the original component manufacturer indicates that failure was due to normal wear and tear, expected consumption through use or improper care or service.

Other Legal Disclaimers:

The above remedy for product defects through repair or replacement by an authorized Smithco distributor or dealer is the purchaser's sole remedy for any defect. This warranty gives you specific legal rights, and you may also have other rights which vary from state to state.

THERE ARE NO OTHER EXPRESS WARRANTIES OTHER THAN THOSE SET FORTH ABOVE. ALL IMPLIED WARRANTIES OF MERCHANTABILITY AND FITNESS FOR USE ARE LIMITED TO THE DURATION OF THE LIMITED WARRANTIES CONTAINED HEREIN.

Some States may not allow limitations on how long an implied warranty lasts, so the above limitation may not apply to you.

THE SMITHCO COMPANY IS NOT LIABLE FOR INDIRECT, INCIDENTAL OR CONSEQUENTIAL DAMAGES IN CONNECTION WITH THE USE OF THE PRODUCT, INCLUDING ANY COST OR EXPENSE OF PROVIDING A SUBSTITUTE PRODUCT OR SERVICE DURING PERIODS OF MALFUNCTION OR NON-USE.

Some states may not allow the exclusion of indirect, incidental or consequential damages, so the above exclusion may not apply to you.

Smithco neither assumes, nor authorizes any person to assume for it, any other liability in connection with the sale or use of this product.

**SMITHCO, INC.
WANYE, PA 19087**

