



Parts Manual

TOURNAMENT ULTRA LITE CE

7576
SN: T8083

Revised December 2018

Product Support: 1020 Hawaii Rd; Humboldt, KS 66748
1-888-422-5173 wj@smithco.com

TABLE OF CONTENTS

TITLE	PAGE
Frame Drawing	1
Frame Parts List	2
Roller Housing Drawing	3
Roller Housing Parts List	4
Steering Drawing	5
Steering Parts List	6
Engine Drawing & Parts List	7
Wiring Drawing & Parts List	8
Hydraulic Plumbing Drawing	9
Hydraulic Plumbing Parts List	10
750-847 Pump Drawing	11
750-847 Pump Parts List	12
Pump Linkage Drawing	13
Pump Linkage Parts List	14
Performance Chart	15-16
7520 Trailer Drawing	17
7520 Trailer Parts List	18
Guide Rail & Roller Stop Installation	19
7525 Trailer Drawing f/7000	20
7525 Trailer Parts List f/7000	21
CE	22-24
SMITHCO Warranty	25-26

7576 FRAME DRAWING

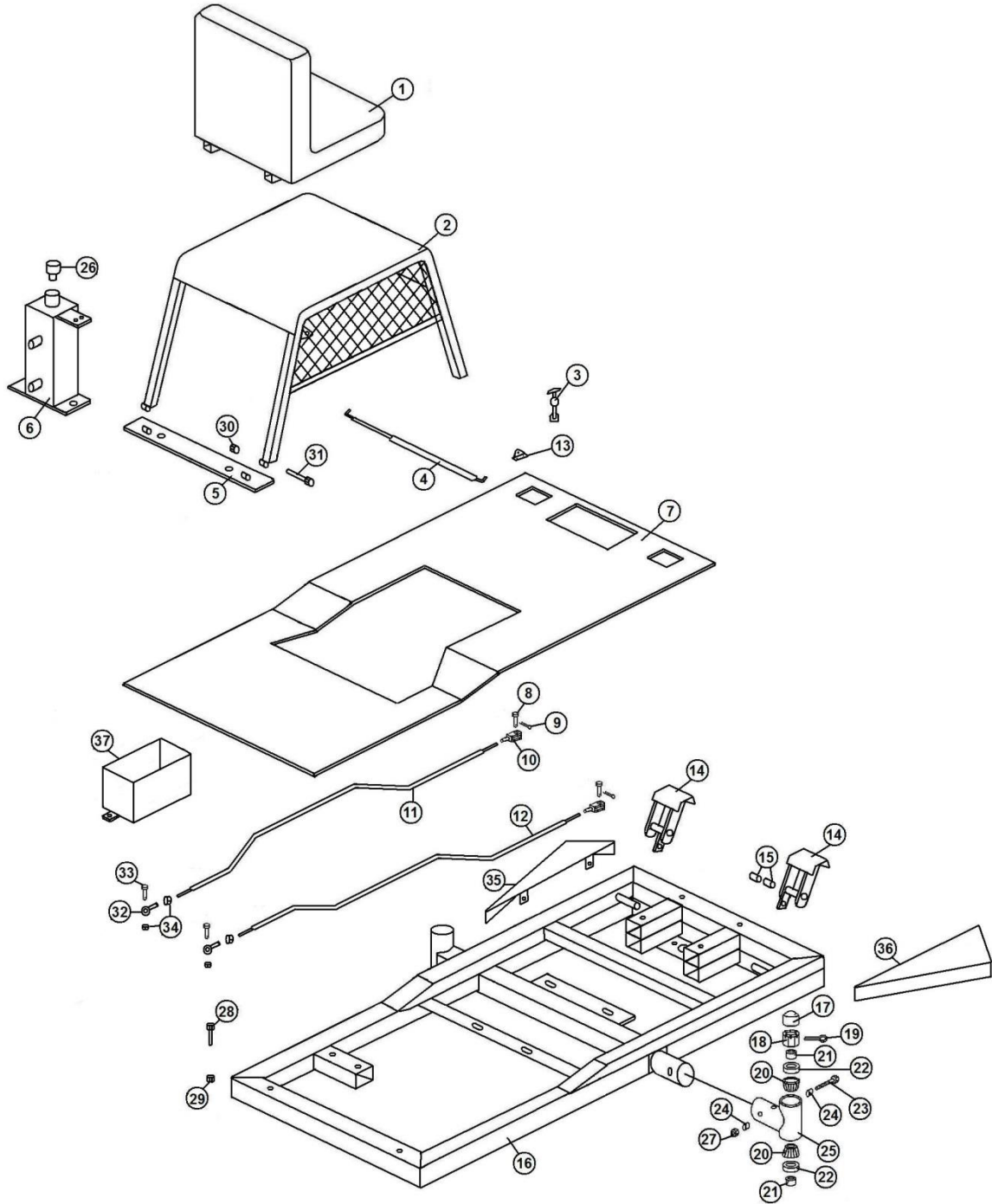

7576 FRAME PARTS LIST

REF#	PART#	DESCRIPTION	QTY.
1	832-123-2	Low-Back "Smithco" Seat Assembly	1
2	750-913	Engine Cover	1
3	750-917	Engine Cover Hold Down 4 7/8"	2
4	750-891	Gas Shock Assembly w/Ball Stud	1
5	750-911	Seat Hinge	1
6	750-916	Oil Tank	1
7	750-908	Deck Plate	1
8	720-078-1	5/16" x 1" Clevis Pin	2
9	720-079	Cotter Pin 3/32" x 3/4"	2
10	11-101-1	1/4" Fine Thread Yoke	2
11	750-915	Left Foot Pedal Rod	1
12	750-914	Right Foot Pedal Rod	1
14	750-912	Foot Pedal	2
15	10-007	Bushing	4
16	750-906	Main Frame	1
17	750-192	1 1/8" Poly Hex Nut & Cap	2
18	932-042	Thick Slotted Hex Nut 1 1/4" – 12	2
19	709-143-1	1/8" x 2 1/2" Cotter Pin	2
20	932-023	Bearing	4
21	932-024	Spacer	2
22	932-022	Seal	4
23	400-061	1/2" x 3 1/2" Bolt	1
24	750-186	Spacer 1/2" ID x 3/4" OD x 1/2"	2
25	750-907	Swivel Axle Bracket	1
26	750-118-1	Oil Tank Cap	1
27	400-112	1/2" Lock Nut	1
28	400-008	5/16" x 2 1/2" Bolt	2
29	400-109	5/16" Lock Nut	2
30	400-116	3/8" Lock Nut	2
31	400-018	3/8" x 2 1/2" Bolt	2
32	44-967	5/16" FT Tie Rod End	2
33	400-002	5/16" x 1" HHCS	2
34	400-281	5/16" Flange Locknut	2
35	750-942	Left Outer Step (CE Only)	1
36	750-943	Right Outer Step (CE Only)	1
37	750-269	Battery Box	1

7576 ROLLER HOUSING DRAWING

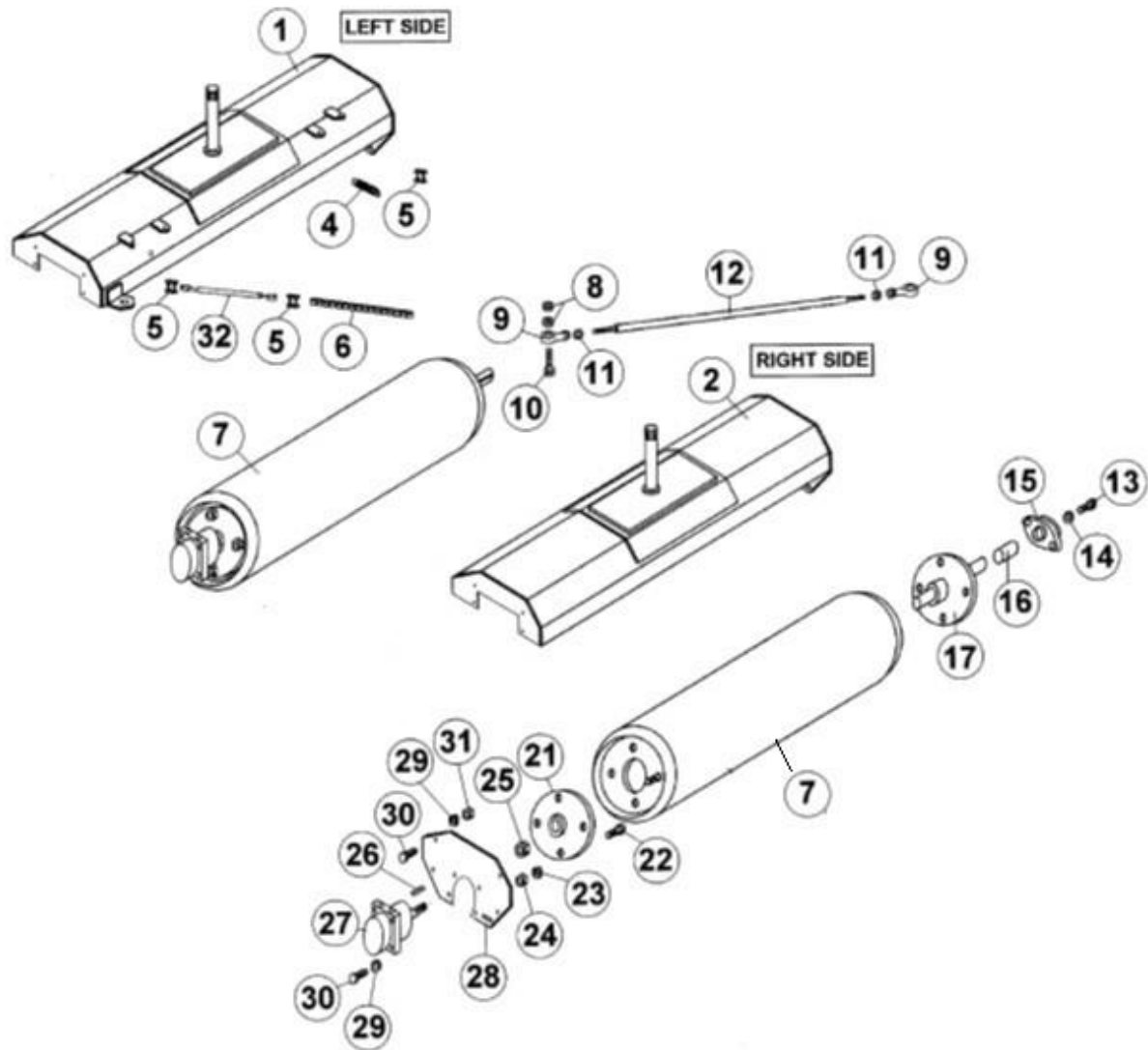

7576 ROLLER HOUSING PARTS LIST

REF#	PART#	DESCRIPTION	QTY.
1	750-825	Left Roller Housing	1
2	750-826	Right Roller Housing	1
4	40-199	Idler Spring	1
5	1083	#50 Master Link	3
6	750-415	#50 Chain 50 pitch w/3 Connecting Links	1
7	750-821	Roller Cylinder	2
8	400-105	1/2" – 13 Hex Nut	5
9	713-806	Ball Joint	2
10	400-056	1/2" – 13 X 2 1/2" HHCS	2
11	400-136	1/2" – 20 Fine Thread Hex Nut	2
12	750-411	Tie Rod	1
13	400-044	1/4" – 20 x 1" Bolt	2
14	400-208	1/4" Lock Washer	2
15	720-004	Flange Bearing	2
16	750-721	Spacer 1 1/4"	2
17	750-220-2	Hub w/Plate, Bushing & Shaft	2
21	750-802	Hub 4 Bolt	2
22	1189	Lug Bolt	8
23	400-210	1/2" Lock Washer	8
24	400-105	1/2" – 13 Hex Nut	8
25	750-801-3	Castle Nut	2
26	740-023	3/16" x 3/4" Key	2
27	750-801	Hydro Gear Motor	2
28	750-827	Bolted End Plate f/Housing	2
29	400-209	3/8" Lock Washer	16
30	400-090	3/8" x 1 1/4" Bolt	16
31	400-103	3/8" Hex Nut	8
32	750-873	Steering Chain Adjuster – Turnbuckle	1

7576 STEERING DRAWING

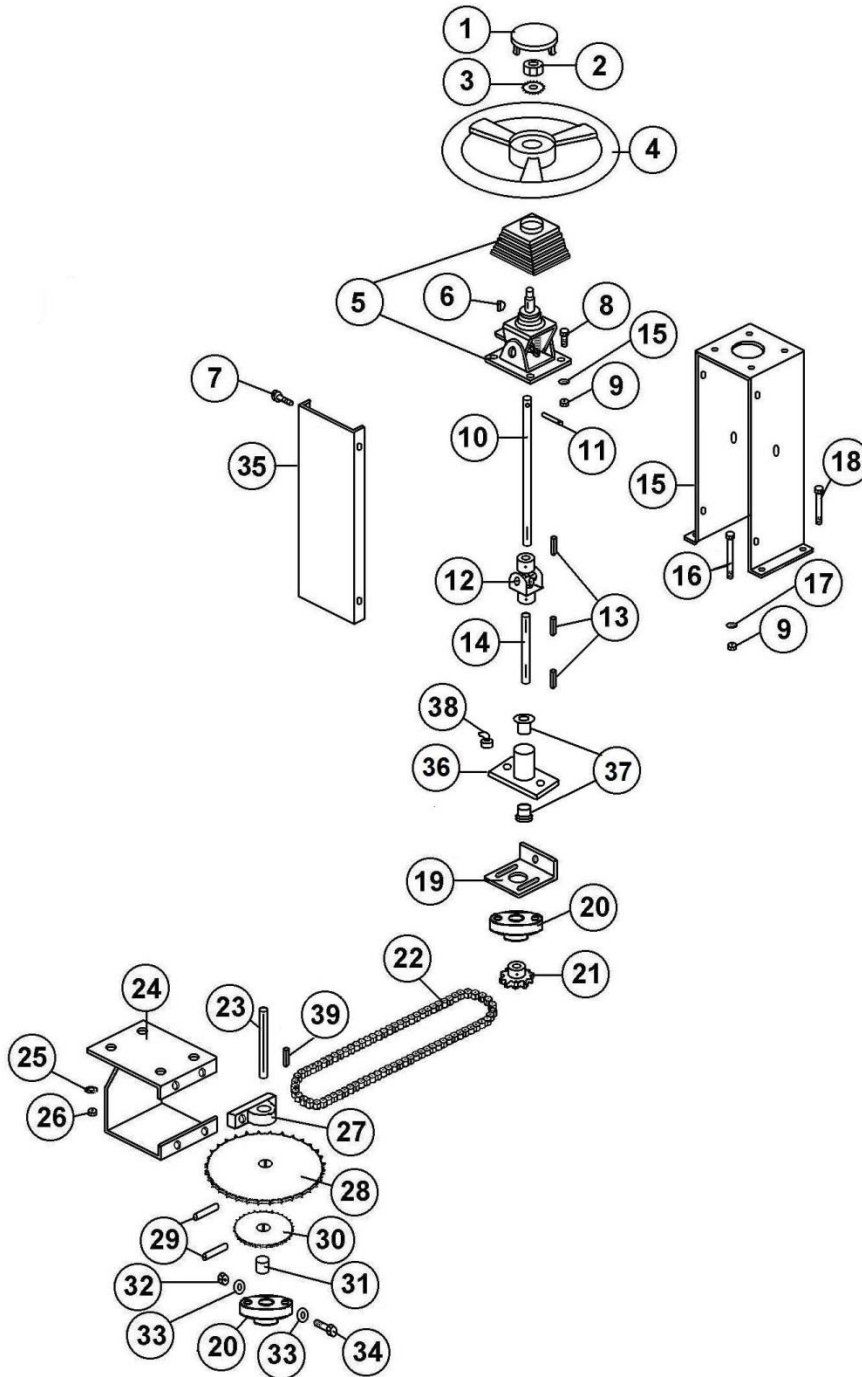

7576 STEERING PARTS LIST

REF#	PART#	DESCRIPTION	QTY.
1	730-046-2	Steering Wheel Cap	1
2	932-122	5/8" – 18 Hex Jam Nut	1
3	400-143	5/8" Lock Washer	1
4	730-046	Steering Wheel	1
5	832-028-1	Tilt Steering Mechanism & Boot w/Pin	1
6	740-023	3/16" x 3/4" Key	1
7	400-073	1/4" x 1" Self Tap Screw	4
8	400-003	5/16" – 18 x 1 1/4" HHCS	4
9	400-102	5/16" – 18 Hex Nut	8
10	750-286	Upper Steering Shaft	1
11	832-030	7/32" x 1 1/4" Spring Pin	1
12	41-120	U-Joint 3/4" x 3/4"	1
13	1088	3/16" x 1" Key	3
14	750-266	Steering Sprocket Shaft	1
15	750-909	Steering Column	1
16	400-010	5/16" – 18 x 5" HHCS	2
17	400-207	5/16" Lock Washer	8
18	400-314	5/16" x 4 1/4" Bolt	2
19	41-194	Chain Adjuster Bracket	1
20	1036	Jackshaft Bearing	2
21	1075	#40 Jackshaft Sprocket 11T	1
22	41-251	#40 Chain x 108 Pitch w/Connecting Link	1
23	750-148-1	Sprocket & Bearing Shaft 5 1/2"	1
24	750-894	Bearing & Sprocket Bracket	1
25	400-103	3/8" – 16 Hex Nut	4
26	400-209	3/8" Lock Washer	4
27	1040	Front Axle Bearing	1
28	750-234	Steering Sprocket 60T 40BS60 x 3/4"	1
29	750-315	1/4" x 2 1/2" Spring Pin	2
30	750-133-1	50BS 19 x 3/4" Sprocket	1
31	750-722	1" Spacer (3/4" ID)	1
32	400-116	3/8" – 16 Locknut	4
33	400-202	5/16" Flat Washer	4
34	400-015	3/8" – 16 x 1 1/2" HHCS	4
35	750-107	Steering Column Cover	1
36	750-195	Steering Shaft Bracket	1
37	520-007	Bronze Bushing	2
38	709-382	1/4" 90° Grease Zert	1
39	1088-1	3/16" x 1 1/2" Key	1

7576 ENGINE DRAWING

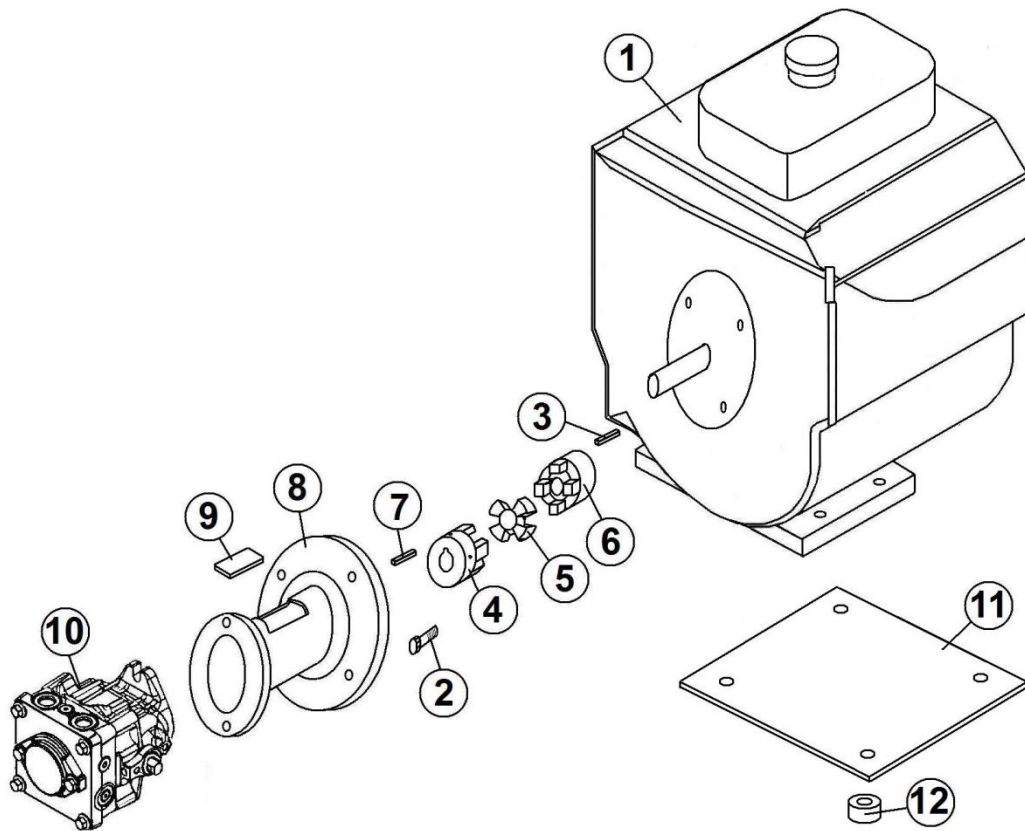

7576 ENGINE PARTS LIST

REF#	PART#	DESCRIPTION	QTY.
1	750-935	8 HP Engine (Model# GX240UT2 -QAR2)	1
2	400-090	3/8" x 1 1/4" Bolt	8
3	1517	1/4" x 1" Key	1
4	750-851	Pump Hub 17mm w / #5 Key	1
5	720-027	Element	1
6	41-147	Engine Coupling 1"	1
7	750-201	3/16" x 1" Key	1
8	750-127	Bell Housing 6"	1
9	750-127-1	Bell Housing Cover	1
10	750-847	16cc without Aux Charge Pump	1
11	750-211	Engine Base	1
12	750-927	Engine Spacer	4

WIRING DRAWING

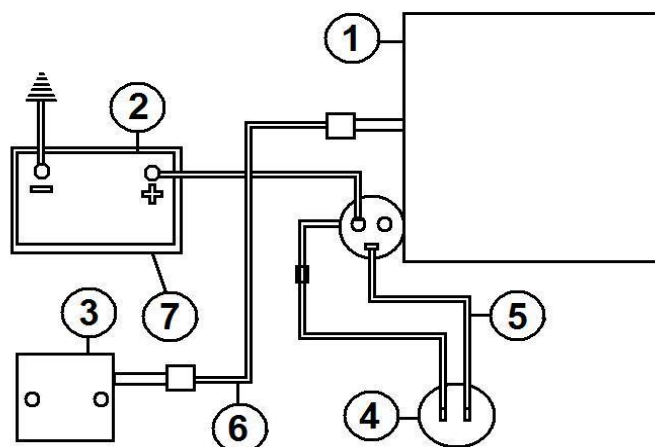

WIRING PARTS LIST

REF#	PART#	DESCRIPTION	QTY.
1	750-935	8 HP Engine (Model# GX240UT2-QAR2)	1
2	750-555-7	PS1230 Battery	1
3	750-555-5	Rectifier	1
4	932-119-1	Safety Seat Switch	1
5	942-049	Wiring Harness f/Seat Switch	1
6	750-555-6	Wiring Harness	1
7	750-555-2	Light Kit Battery Box	1

HYDRAULIC PLUMBING DRAWING

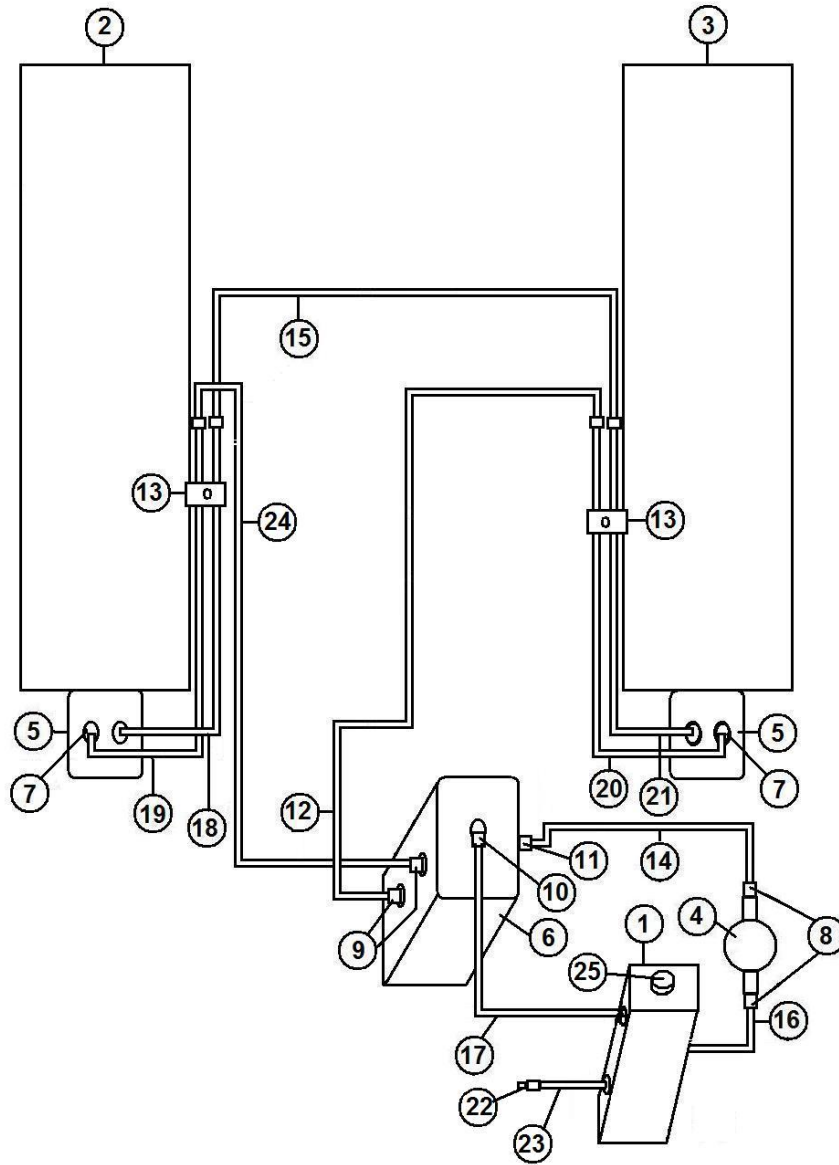

HYDRAULIC PLUMBING PARTS LIST

REF#	PART#	DESCRIPTION	QTY.
1	750-916	Oil Tank	1
2	750-825	Left Roller Housing	1
3	750-826	Right Roller Housing	1
4	750-302	Filter Head	1
5	750-801	Wheel Motor	2
6	750-847	16cc without Aug Charge Pump	1
7	750-326	Wheel Motor Fitting	4
8	750-325	Oil Filter Head Fitting	2
9	750-322	Pump Fitting	2
10	750-324	Pump Fitting Top	1
11	750-295	Pump Fitting	1
12	750-920-1	Hyd Hose 57" x 1/2" (w/o 90° to Straight)	1
13	750-502	Hard Line Clamp	2
14	750-920-2	Hydraulic Hose 14" – Pump to Filter	1
15	750-920-3	Hydraulic Hose 35"	2
16	750-920-4	Hydraulic Hose 11" – Oil Tank to Filter Head	1
17	750-920-5	Hydraulic Hose 7" – Oil Tank to Pump	1
18	750-519	Hard Line Long Left Side	1
19	750-520	Hard Line Short Left Side	1
20	750-506	Hard Line Long Right Side	1
21	750-507	Hard Line Short Right Side	1
22	750-923	Drain Cap	1
23	750-920-6	Drain Hose	1
24	750-920-7	Hydraulic Hose 52"	1

NOTE: OIL FILTER IS A PART# 750-300

COMPLETE HOSE KIT IS A PART# 750-920

750-847 PUMP DRAWING

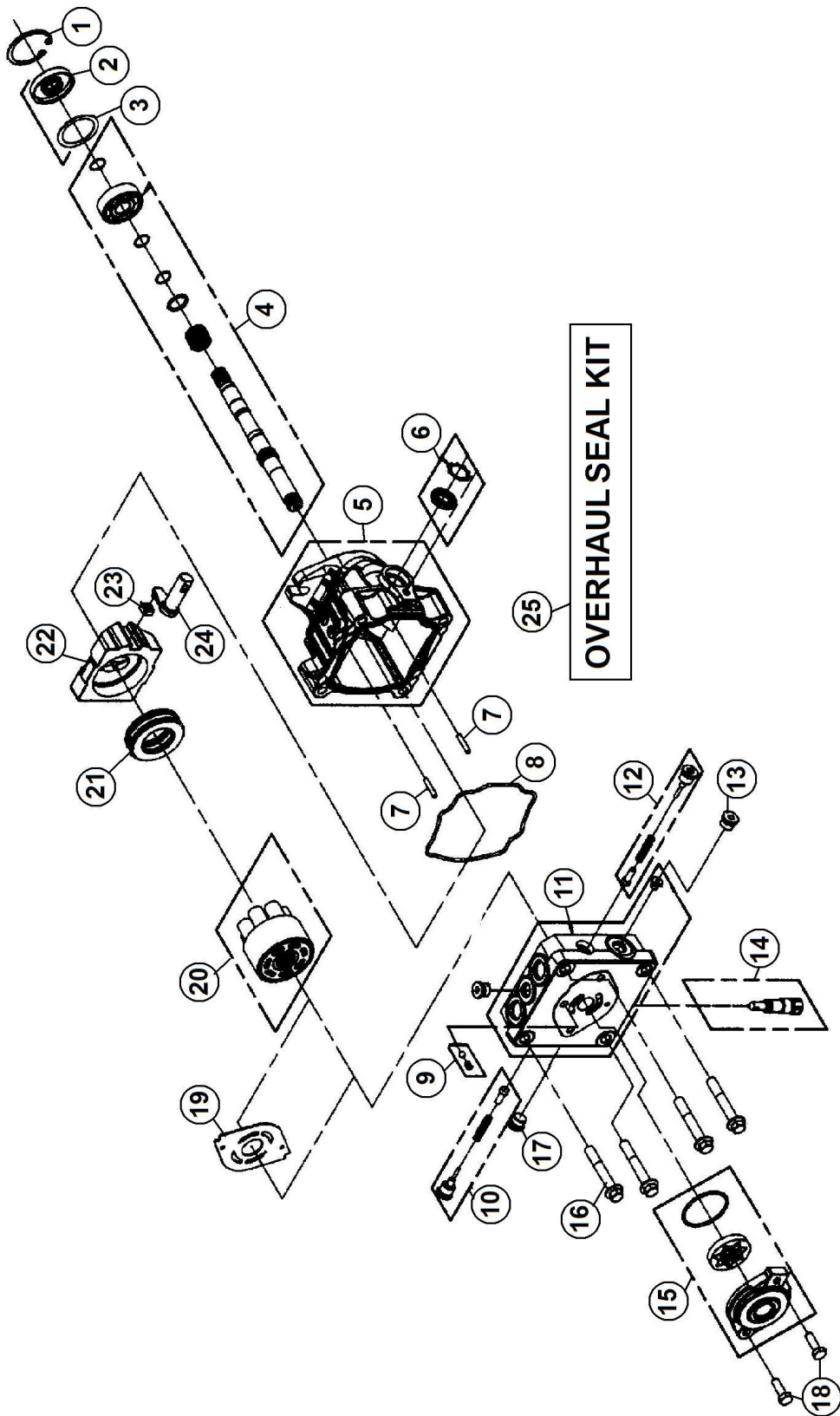

750-847 PUMP PARTS LIST

REF#	PART#	DESCRIPTION	QTY.
1	750-847-3	Retaining Ring	1
2	750-847-4	Lip Seal	1
3	750-847-5	Spacer	1
4	750-847-6	Shaft Kit	1
5	750-847-7	Housing	1
6	750-847-8	Trunnion Seal Kit	1
7	750-228-15	Pin	2
8	750-847-9	O-Ring	1
9	750-847-10	Charge Relief	1
10	750-847-11	Shock Valve Kit	1
11	750-847-12	End Cap	1
12	750-847-11	Shock Valve Kit	1
13	750-847-13	Plug	1
14	750-228-7	Bypass Kit	1
15	750-847-14	Charge Pump	1
16	750-847-15	Screw	4
17	750-847-13	Plug	1
18	750-847-16	Screw	2
19	750-847-17	Valve Plate	1
20	750-847-18	Cylinder Block	1
21	750-847-19	Thrust Bearing	1
22	750-847-20	Swash Plate	1
23	750-128-38	Slot Guide	1
24	750-847-21	Trunnion Arm	1
25	750-849	Seal Kit	1

PUMP LINKAGE DRAWING

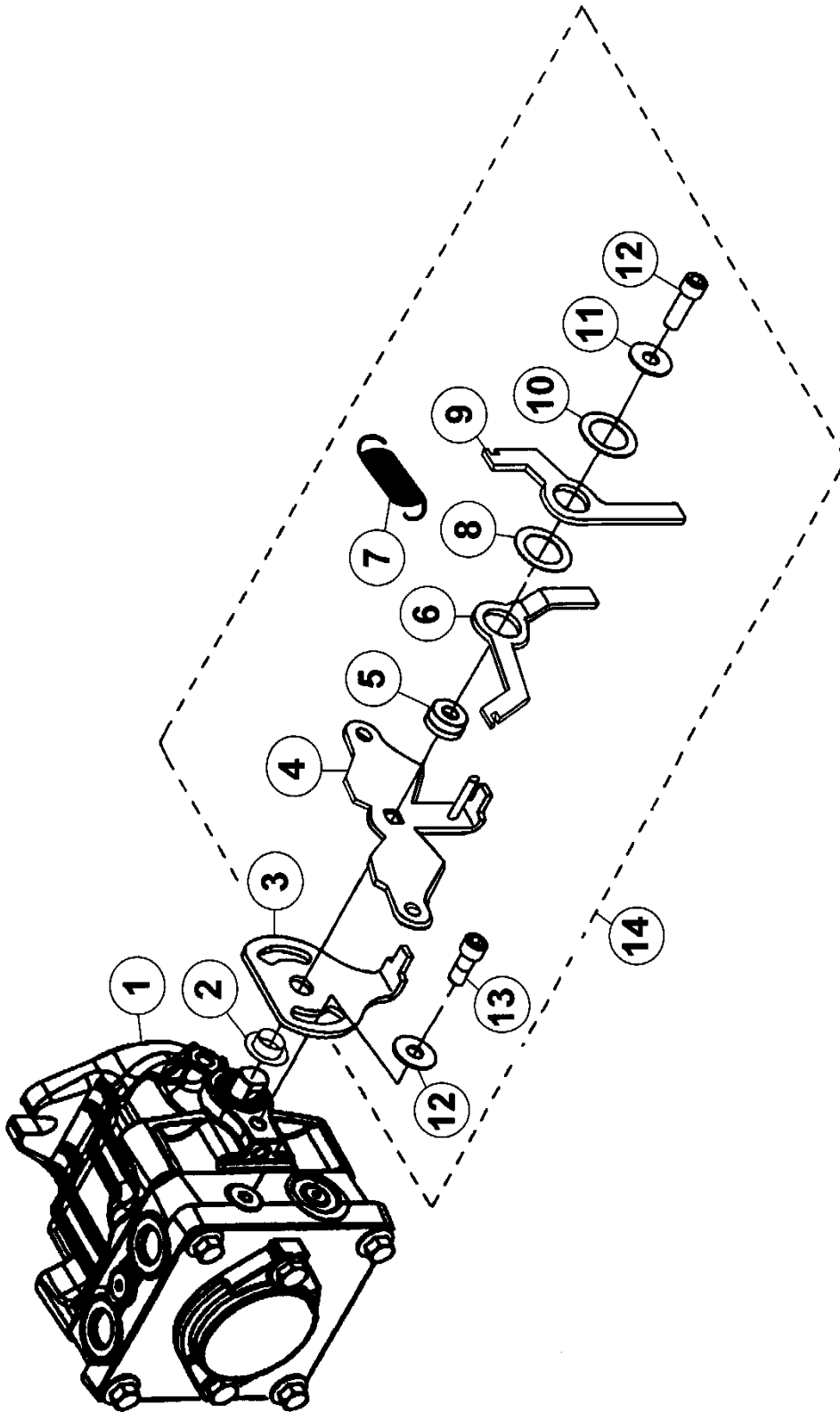

PUMP LINKAGE PARTS LIST

REF.#	PART#	DESCRIPTION	QTY.
1	750-847	16cc without Aug Charge Pump	1
2	750-228-30	Bushing	1
3	750-343-1	Shift Lever Top (New)	1
3	750-343	Shift Lever Top (Old)	1
4	750-344-1	Shift Lever Bottom w/Bolt (Sq. Hole .470)	1
4	750-344	Shift Lever Bottom (Sq. Hole .350)	1
5	750-228-31	Bushing	1
6	750-345	Shift lever Right (Bent)	1
7	750-229-1	Gold Spring	1
8	750-228-32	Nylon Washer	1
9	750-346	Shift Lever Left (Straight)	1
10	750-228-33	Nylon Washer	1
11	750-228-34	5/16" Flat Washer	2
12	750-228-35	Allen Head Bolt	1
13	750-228-36	Allen Head Bolt	1
14	750-228-37	Pump Bracket Kit	1

PERFORMANCE CHART

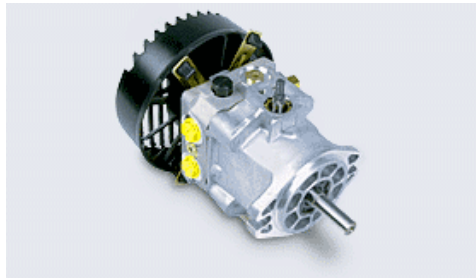

Product Type		PC	PG	PJ	PR	PW
Displacement	in ³ /rev [cc/rev]	0.37 [6.1]	0.62 [10.2]	0.73 [12]	0.97 [16]	1.33 [21.8]
Input Speed						
Maximum Unloaded	rpm	3600	3600	3600	3600	3600
Minimum Loaded	rpm	1800	1800	1800	1800	1800
System Operating Pressure						
Continuous	psi [bar]	750 [51]	1000 [70]	1000 [70]	1250 [86]	1250 [86]
Intermittent	psi [bar]	1750 [120]	2100 [145]	2100 [145]	2500 [172]	2500 [172]
Peak	psi [bar]	2500 [172]	3500 [240]	3500 [240]	3750 [260]	3750 [260]
Pump Performance						
@ 2400 rpm/1000 psi	gpm [l/min]	3.6 [13.6]	6.1 [23.1]	7.1 [26.8]	9.6 [36.3]	13.1 [49.6]
@ 3000 rpm/1000 psi	gpm [l/min]	4.5 [17.0]	7.6 [28.8]	8.9 [33.6]	12 [45.4]	16.4 [62.1]
@ 3600 rpm/1000 psi	gpm [l/min]	5.4 [20.4]	9.2 [34.8]	10.8 [40.8]	14.4 [54.5]	19.6 [74.2]
Case Pressure						
Maximum @ Cold Start	psi [bar]	10 [0.7]	10 [0.7]	10 [0.7]	25 [1.7]	25 [1.7]
Continuous - Max.	psi [bar]	4 [0.3]	4 [0.3]	4 [0.3]	10 [0.7]	10 [0.7]
Inlet Vacuum						
Maximum Continuous Inches Mercury		4	4	4	4	4
Charge Pump Displacement(s)	in ³ /rev [cc/rev]	.13 [2.1]	0.11/0.13 [1.9/2.1]	0.19 [3.2]	0.13/0.19 [2.1/3.2]	0.13/0.19 [2.1/3.2]
Auxiliary Pump Displacement	in ³ /rev [cc/rev]	0.19 [3.2]	0.19 [3.2]	0.19 [3.2]	0.19 [3.2]	0.19 [3.2]
Auxiliary Pump Relief Setting	psi [bar]	650 [45]	650 [45]	650 [45]	650 [45]	650 [45]
Auxiliary Pump Performance @3200 rpm, 500 psi, 70 SUS [13 Cst] oil, & 180°F	gpm [l/min]	1.8 - 2.0 [6.8 - 7.6]	1.8 - 2.0 [6.8 - 7.6]	1.8 - 2.0 [6.8 - 7.6]	1.8 - 2.0 [6.8 - 7.6]	1.8 - 2.0 [6.8 - 7.6]
Control Torque Required to Stroke Pump [Approximate - 20° External Stroke Angle]		75	85	85	95	105

lb-in / 1000 psi	[8.5]	[9.6]	[9.6]	[10.7]	[11.9]
[N-m / 70 bar]	55	60	60	75	85
lb-in / 500 psi	[6.2]	[6.8]	[6.8]	[8.5]	[9.6]
[N-m / 35 bar]					

Pump Oil Temperature						
Maximum Intermittent (hottest point)	°F	230	230	230	230	230
	[°C]	[110]	[110]	[110]	[110]	[110]
Normal Operating Range	°F	-10 to 200	-10 to 200	-10 to 200	-10 to 200	-10 to 200
	[°C]	[-23 to 93]	[-23 to 93]	[-23 to 93]	[-23 to 93]	[-23 to 93]

Fluid Viscosity Limits @ 230°F [110°C]

Optimum	SUS[cSt]	70 [13]	70 [13]	70 [13]	70 [13]	70 [13]
Minimum	SUS[cSt]	55 [9]	55 [9]	55 [9]	55 [9]	55 [9]

Weight of Unit

lbs [kg]	7 [3.2]	8 [3.6]	12.65 [5.7]	12 [5.4]	14 [6.3]
----------	---------	---------	-------------	----------	----------

Inlet Filtration Requirement

Nominal	micron	25	25	25	25	25
---------	--------	----	----	----	----	----

7520 TRAILER DRAWING

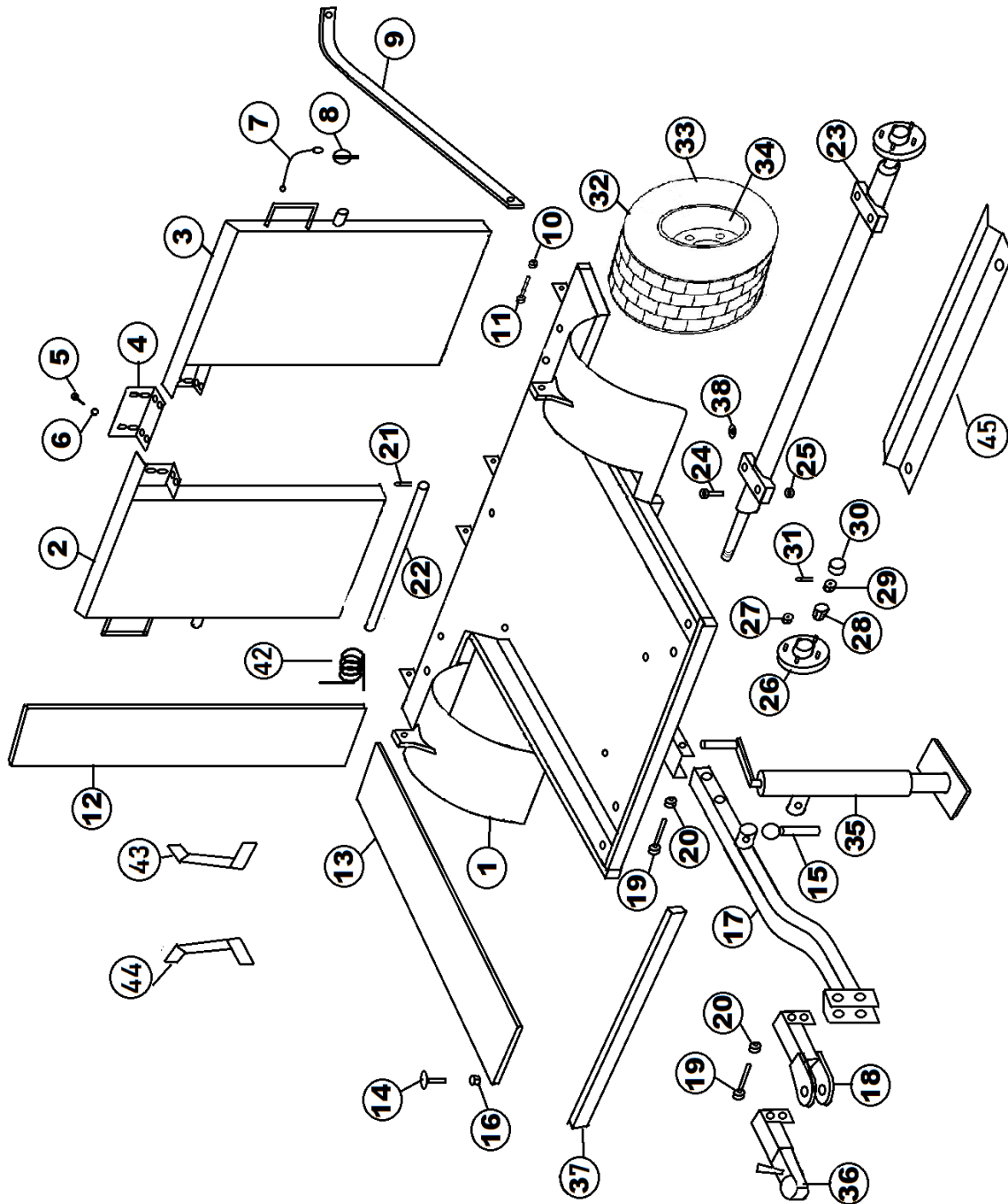

7520 TRAILER PARTS LIST

REF#	PART#	DESCRIPTION	QTY.
1	750-430	Trailer Bed	1
2	750-432	Right Side Ramp	1
3	750-431	Left Side Ramp	1
4	750-433	Ramp Plate	1
5	400-321	1/4" X 3/4" X 20 Truss Head Bolt	8
6	400-342	1/4" Flanged Locknut	8
7	750-422	3/64 x 6 Lanyard	2
8	750-421	Snap Pin 3/16 x 1 1/4"	2
9	750-437	Ramp Latch	2
10	400-112	1/2" - 13 Locknut	2
11	400-027	1/2" - 13 x 1 1/2" HHCS	2
12	750-164-7	Rubber Matting f/7520 Ramp 55" x 7"	4
13	750-438	Rubber Matting f/Bed 47" x 7"	2
14	400-255	Elevator Bolt	12
15	750-961-1	Jack Pin	1
16	400-281	5/16" Flanged Locknut	12
17	750-434	Drawbar	1
18	750-435	Drawbar Hitch	1
19	400-061	1/2" - 13 x 3 1/2" HHCS	4
20	400-112	1/2" - 13 Locknut	4
21	40-168	Cotter Pin 1/8 x 1"	4
22	750-436	Ramp Pin	2
23	750-960	Axle	1
24	400-015	3/8" - 16 x 1 1/2" HHCS	4
25	400-116	3/8" Locknut	4
26	2027-1	Hub Only	2
27	1187	Lug Nut	8
28	2028-1	Bearing	4
29	709-126	Spindle Nut	2
30	2024	Dust Cap	2
31	720-043	Cotter Pin	2
32	750-967	Wheel & Tire	2
33	750-967-1	Tire	2
34	2026	Wheel	2
35	750-961	Jackstand	1
36	750-435-1	Ball Hitch	1
37	750-440	Roller Stop	1
38	400-202	5/16" Flat Washer	8
39	400-014	3/8" - 16 x 1" HHCS	2
40	400-202	5/16" Flat Washer	12
41	400-116	3/8" Locknut	2
42	750-444	Spring	8
43	750-976	Left Guide	1
44	750-975	Right Guide	1
45	750-406-1	Roller Stop	1

7520 ROLLER GUIDE INSTALLATION



ROLLER STOP INSTALLATION



7525 TRAILER DRAWING F/7000 ROLLER

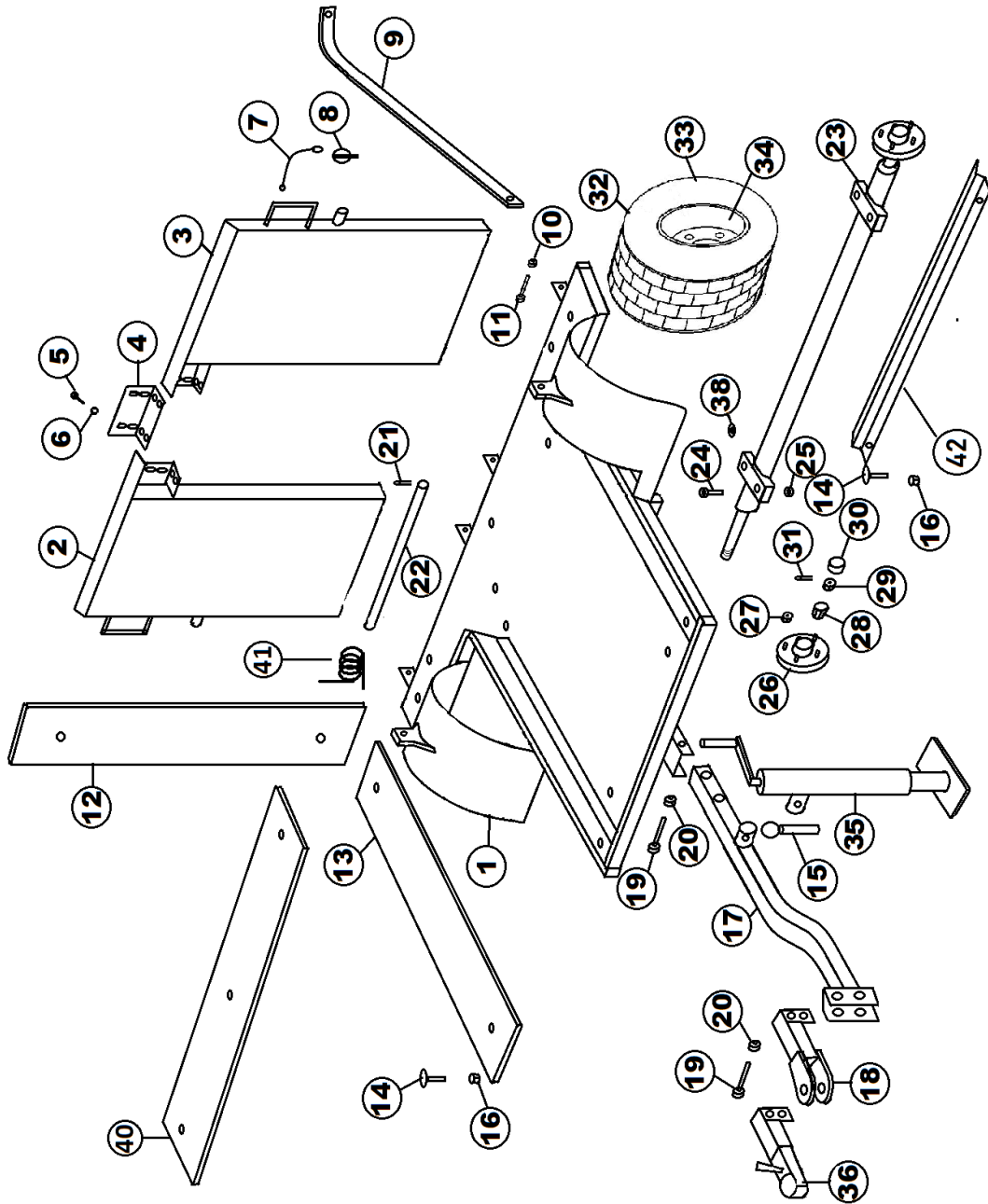

7525 TRAILER PARTS LIST F/7000 ROLLER

REF#	PART#	DESCRIPTION	QTY.
1	750-430	Trailer Bed	1
2	750-432	Right Side Ramp	1
3	750-431	Left Side Ramp	1
4	750-433	Ramp Plate	1
5	400-321	1/4" X 3/4" X 20 Truss Head Bolt	8
6	400-342	1/4" Flanged Locknut	8
7	750-422	3/64 x 6 Lanyard	2
8	750-421	Snap Pin 3/16 x 1 1/4"	2
9	750-441	Ramp Latch	2
10	400-112	1/2" - 13 Locknut	2
11	400-027	1/2" - 13 x 1 1/2" HHCS	2
12	750-439	Rubber Matting f/7525 Ramp 55" x 18"	2
13	750-438	Rubber Matting f/Bed 47" x 7"	2
14	400-255	Elevator Bolt	7
15	750-961-1	Jack Pin	1
16	400-281	5/16" Flanged Locknut	12
17	750-434	Drawbar	1
18	750-435	Drawbar Hitch	1
19	400-061	1/2" - 13 x 3 1/2" HHCS	4
20	400-112	1/2" - 13 Locknut	4
21	40-168	Cotter Pin 1/8 x 1"	4
22	750-436	Ramp Pin	2
23	750-960	Axle	1
24	400-015	3/8" - 16 x 1 1/2" HHCS	4
25	400-116	3/8" Locknut	4
26	2027-1	Hub Only	2
27	1187	Lug Nut	8
28	2028-1	Bearing	4
29	709-126	Spindle Nut	2
30	2024	Dust Cap	2
31	720-043	Cotter Pin	2
32	750-967	Wheel & Tire	2
33	750-967-1	Tire	2
34	2026	Wheel	2
35	750-961	Jackstand	1
36	750-435-1	Ball Hitch	1
38	400-202	5/16" Flat Washer	10
40	750-164-8	Rubber Matting f/Bed 63" x 7"	1
41	750-444	Spring	8
42	750-406-1	Roller Stop	1
*	400-207	Lock Washer 5/16"	
*	400-102	5/16" Nut	

*Part of bolt bag

**DECLARATION OF CONFORMITY • ДЕКЛАРАЦИЯ ЗА СЪОТВЕТСТВИЕ • PROHLÁŠENÍ O SHODĚ •
OVERENSSTEMMELSESERKLÆRING • CONFORMITEITSVERKLARING • VASTAVUSDEKLARATSIOON •
VAATIMUSTENMUKAISUUSVAKUUTUS • DECLARATION DE CONFORMITE •
KONFORMITÄTSEKTLÄRUNG • ΔΗΛΩΣΗ ΣΥΜΜΟΡΦΩΣΗΣ • MEGFELELŐSÉGI NYILATKOZAT •
DICHIAZIONE DI CONFORMITÀ • ATBILSTĪBAS DEKLARĀCIJA • ATITIKTIES DEKLARACIJA •
DIKJARAZZJONI TAL-KONFORMITÀ • DEKLARACJA ZGODNOŚCI • DECLARAÇÃO DE CONFORMIDADE •
DECLARAȚIE DE CONFORMITATE • VYHLÁŠENIE O ZHODE • IZJAVA O SKLADNOSTI • DECLARACIÓN
DE CONFORMIDAD • DEKLARATION OM ÖVERENSTÄMMELSE**

<p>Business name and full address of the manufacturer • Търговско име и пълен адрес на производителя • Obchodní jméno a plná adresa výrobce • Producentens firmanavn og fulde adresse • Bedrijfsnaam en volledig adres van de fabrikant • Tootja ärinimi ja täielik address • Valmistajan toiminimi ja täydellinen osoite • Nom commercial et adresse complète du fabricant • Firmenname und vollständige Adresse des Herstellers • Επωνυμία και ταχυδρομική διεύθυνση κατασκευαστή • A gyártó üzleti neve és teljes címe • Ragione sociale e indirizzo completo del fabbricante • Uzņēmuma nosaukums un pilna ražotāja adrese • Verslo pavadinimas ir pilnas gamintojo adresas • Isem kummerčjali u indirizz sħiħ tal-fabbrikant • Nazwa firmy i pelny adres producenta • Nome da empresa e endereço completo do fabricante • Denumirea comercială și adresa completă a producătorului • Obchodný názov a úplná adresa výrobcu • Naziv podjetja in polni naslov proizvajalca • Nombre de la empresa y dirección completa del fabricante • Tillverkarens företagsnamn och kompletta adress</p>	<p align="center">Smithco Inc. 34 West Avenue Wayne PA USA 19087-3311</p>
<p>Product Code • Код на продукта • Kód výrobku • Produktkode • Productcode • Toote kood • Tuotekoodi • Code produit • Produktcode • Κωδικός προϊόντος • Termékkód • Codice prodotto • Produkta kods • Produkto kodas • Kodići tal-Prodott • Kod produktu • Código do Produto • Cod produs • Kód výrobku • Oznaka proizvoda • Código de producto • Produktkod</p>	<p align="center">7576</p>
<p>Machine Name • Наименование на машината • Název stroje • Maskinnavn • Machinenaam • Masina nimi • Laitteen nimi • Nom de la machine • Maschinenbezeichnung • Ονομασία μηχανήματος • Gépnév • Denominazione della macchina • Iekārtas nosaukums • Mašinos pavadinimas • Isem tal-Magna • Nazwa urządzenia • Nome da Máquina • Numele echipamentului • Názov stroja • Naziv stroja • Nombre de la máquina • Maskinens namn</p>	<p align="center">Tournament Ultra Lite</p>
<p>Designation • Предназначение • Označení • Betegnelse • Benaming • Nimetus • Tyyppimerkintä • Pažymėjimas • Bezeichnung • Χαρακτηρισμός • Megnevezés • Funzione • Apzīmējums • Lithuanian • Denominazzjoni • Oznaczenie • Designação • Specificație • Označenie • Namen stroja • Descripción • Beteckning</p>	<p align="center">Greens Roller</p>
<p>Serial Number • Сериен номер • Sériové číslo • Seriennummer • Seriennummer • Seerianumber • Valmistusnumero • Numéro de série • Seriennummer • Σειριακός αριθμός • Sorozatszám • Numero di serie • Sērijas numurs • Serijos numeris • Numru Serjali • Numer seryjny • Número de Série • Număr de serie • Sériové číslo • Serijska številka • Número de serie • Seriennummer</p>	<p align="center">T7903</p>
<p>Engine • Двигател • Motor • Motor • Motor • Mootor • Moottori • Moteur • Motor • Μηχανή • Modulnėv • Motore • Dzinējs • Variklis • Saħħa Netta Installata • Silnik • Motor • Motor • Motor • Motor • Motor • Motor</p>	<p align="center">Honda GX240</p>
<p>Net Installed Power • Нетна инсталирана мощност • Čistý instalovaný výkon • Installeret nettoeffekt • Netto geïnstalleerd vermogen • Installeeritud netovõimsus • Asennettu nettoteho • Puissance nominale nette • Installierte Nettoleistung • Καθαρή εγκατεστημένη ισχύς • Nettó beépített teljesítmény • Potenza netta installata • Paredzētā tīkla jauda • Grynoji galia • Wisa' tal-Qtugh • Moc zainstalowana netto • Potência instalada • Puterea instalată netă • Čistý inštalovaný výkon • Neto vgrajena moč • Potencia instalada neta • Nettoeffekt</p>	<p align="center">6 KW</p>
<p>Conforms to Directives • В съответствие с директивите • Splňuje podmínky směrníc • Er i overensstemmelse med direktiver • Voldoet aan de richtlijnen • Vastab direktiividele • Direktiivien mukainen • Conforme aux directives • Entspricht Richtlinien • Ακολουθήστε πιστά τις Οδηγίες • Megfelel az irányelveknek • Conforme alle Direttive • Atbilst direktīvām • Atitinka direktyvų reikalavimus • Valutazzjoni tal-Konformità • Dyrektywy związane • Cumple as Directivas • Respectă Directivele • Je v súlade so smernicami • Skladnost z direktivami • Cumple con las Directivas • Uppfyller direktiv</p>	<p align="center">2006/42/EC; 2000/14/EC Annex VI . Part 1</p>
<p>Conformity Assessment • Оценка за съответствие • Hodnocení plnění podmínek • Overensstemmelsesvurdering • Conformiteitsbeoordeling • Vastavushindamine • Vaatimustenmukaisuuden arviointi • Evaluation de conformité • Konformitätsbeurteilung • Διαπίστωση Συμμόρφωσης • Megfelelőség-értékelés • Valutazione della conformità • Atbilstības novērtējums • Atitikties įvertinimas • Livell tal-Qawwa tal-Foss Imkejjel • Ocena zgodności • Avaliação de Conformidade • Evaluarea conformității • Vyhodnotenie zhodnosti • Ocena skladnosti • Evaluación de conformidad • Bedömning av överensstämmelse</p>	<p align="center">2006/42/EC Annex VIII</p>
<p>Measured Sound Power Level • Измерено ниво на звукова мощност • Naměřený akustický výkon • Målte lydstyrkeniveau • Gemeten geluidsniveau • Mõõdetud helivõimsuse tase • Mitattu äänitehotaso • Niveau de puissance sonore mesuré • Gemessener Schalldruckpegel • Σταθμισμένο επίπεδο ηχητικής ισχύος • Mért hangteljesítményszint • Livello di potenza sonora misurato • Izmēritais skaņas jaudas līmenis • Išmatuotas garso stiprumo lygis • Livell tal-Qawwa tal-Foss Iggarranti • Moc akustyczna mierzona • Nivel sonoro medido • Nivelul măsurat al puterii acustice • Nameraná hladina akustického výkonu • Izmerjena raven vzočne moči • Nivel de potencia sonora medido • Uppmätt ljudeffektsnivå</p>	<p align="center">77 db(A)Lwa</p>

<p>Guaranteed Sound Power Level • Гарантирано ниво на звукова мощност • Garantovaný akustický výkon • Garanteret lydstyrkeniveau • Gegarandeerd geluidsniveau • Garanteeritud helivõimsuse tase • Taattu äänitehotaso • Niveau de puissance sonore garanti • Garantierter Schalldruckpegel • Εγγυημένο επίπεδο ηχητικής ισχύος • Szavatolt hangteljesítményszint • Livello di potenza sonora garantito • Garantētais skaņas jaudas līmenis • Garantuotas garso stiprumo lygis • Livell tal-Qawwa tal-Foss • Iggarantit • Moc akustyczna gwarantowana • Nível sonoro farantido • Nivelul garantat al puterii acustice • Garantovaná hladina akustického výkonu • Zajamčena raven zvočne moči • Nivel de potencia sonora garantizado • Garanterad ljudeffektsnivå</p>	<p>88 db(A)Lwa</p>
<p>Conformity Assessment Procedure (Noise) • Оценка за съответствие на процедурата (Шум) • Postup hodnocení plnění podmínek (hluk) • Procedure for overensstemmelsesvurdering (Støj) • Procedure van de conformiteitsbeoordeling (geluid) • Vastavushindamismenetlus (müra) • Vaatimustenmukaisuuden arviointimenettely (Melu) • Procédure d'évaluation de conformité (bruit) • Konformitätsbeurteilungsverfahren (Geräusch) • Διαδικασία Αξιολόγησης Συμμόρφωσης (Θόρυβος) • Megfelelőség-értékelési eljárás (Zaj) • Procedura di valutazione della conformità (rumore) • Atbilstības novērtējuma procedūra (troksnis) • Atitikties įvertinimo procedūra (garsas) • Procedura tal-Valutazzjoni tal-Konformità (Foss) • Procedura oceny zgodności (poziom hałas) • Processo de avaliação de conformidade (nível sonoro) • Procedura de evaluare a conformității (zgomot) • Postup vyhodnocovania zhodnosti (hluk) • Postopek za ugotavljanje skladnosti (hrup) • Procedimiento de evaluación de conformidad (ruido) • Procedur för bedömning av överensstämmelse (buller)</p>	<p>2000/14/EC Annex VI Part 1</p>
<p>UK Notified Body for 2000/14/EC • Нотифициран орган в Обединеното кралство за 2000/14/EO • Úřad certifikovaný podle směrnice č. 2000/14/EC • Det britiske bemyndigede organ for 2001/14/EF • Engels adviesorgaan voor 2000/14/EG • Ühendkuningriigi teavitatud asutus direktiivi 2000/14/EÜ mõistes • Direktiivin 2000/14/EY mukainen ilmoitettu tarkastuslaitos Isonsa-Britanniassa • Organisme notifié concernant la directive 2000/14/CE • Britische benannte Stelle für 2000/14/EG • Κοινοποιημένος Οργανισμός Ηνωμένου Βασιλείου για 2000/14/ΕΚ • 2000/14/EK – egyesült királyságbeli bejelentett szervezet • Organismo Notificato in GB per 2000/14/CE • 2000/14/EK AK reģistrētā organizācija • JK notifikuotosios įstaigos 2000/14/EC • Korp Notifikat tar-Renju Unit għal 2000/14/KE • Dopuszczona jednostka badawcza w Wielkiej Brytanii wg 2000/14/WE • Entidade notificada no Reino Unido para 2000/14/CE • Organism notificat în Marea Britanie pentru 2000/14/CE • Notifikovaný orgán Spojeného královstva pro směrnici 2000/14/ES • Britanski priglašeni organ za 2000/14/ES • Cuerpo notificado en el Reino Unido para 2000/14/CE • Anmält organ för 2000/14/EG i Storbritannien</p>	<p>Smithco / Humboldt 1020 Hawaii Rd. Humboldt Ks 66748 USA</p>
<p>Operator Ear Noise Level • Оператор на нивото на доловим от ухото шум • Hladina hluku v oblasti uší operátora • Støjniveau i førers ørehøjde • Geluidsniveau oor bestuurder • Műratase operaatori kõrvas • Melutaso käyttäjän korvan kohdalla • Niveau de bruit à hauteur des oreilles de l'opérateur • Schallpegel am Bedienerohr • Επίπεδο θορύβου σε λειτουργία • A kezelő fülénél mért zajszint • Livello di potenza sonora all'orecchio dell'operatore • Trokšņa līmenis pie operatora auss • Dirbančiojo su mašina patiriamas triukšmo lygis • Livell tal-Foss fil-Widna tal-Operatur • Dopuszczalny poziom hałasu dla operatora • Nível sonoro nos ouvidos do operador • Nivelul zgomotului la urechea operatorului • Hladina hluku pôsobiaci na sluch operátora • Raven hrupa pri ušesu upravljavca • Nivel sonoro en el oído del operador • Ljudnivå vid förarens öra</p>	<p>88 db(A)Lwa (2006/42/EC)</p>
<p>Harmonised standards used • Използвани хармонизирани стандарти • Použité harmonizované normy • Brugte harmoniserede standarder • Gebruikte geharmoniseerde standaards • Kasutatud ühtlustatud standardid • Käytetyt yhdenmukaistetut standardit • Normes harmonisées utilisées • Angewandte harmonisierte Normen • Εναρμονισμένα πρότυπα που χρησιμοποιήθηκαν • Harmonizált szabványok • Standard armonizzati applicati • Izmantotie saskaņotie standarti • Panaudoti suderinti standarta i • Standards armonizzati usati • Normy spójne powiązane • Normas harmonizadas usadas • Standardele armonizate utilizate • Použité harmonizované normy • Uporabljeni usklajeni standardi • Estándares armonizados utilizados • Harmoniserade standarder som används</p>	<p>BS EN ISO 12100-1 BS EN ISO 13857 BS EN 349</p>
<p>Technical standards and specifications used • Използвани технически стандарти и спецификации • Použité technické normy a specifikace • Brugte tekniske standarder og specifikationer • Gebruikte technische standaards en specificaties • Kasutatud tehnilised standardid ja spetsifikatsioonid • Käytetyt tekniset standardit ja eritelmät • Spécifications et normes techniques utilisées • Angewandte technische Normen und Spezifikationen • Τεχνικά πρότυπα και προδιαγραφές που χρησιμοποιήθηκαν • Műszaki szabványok és specifikációk • Standard tecnici e specifiche applicati • Izmantotie tehnikie standarti un specifikācijas • Panaudoti techniniai standarta ir techninė informacija • Standards u specifikacijonijiet technici užati • Normy i specyfikacje techniczne powiązane • Normas técnicas e especificações usadas • Standardele tehnice și specificațiile utilizate • Použité technické normy a špecifikácie • Uporabljeni tehnični standardi in specifikacije • Estándares y especificaciones técnicas utilizadas • Tekniska standarder och specifikationer som används</p>	<p>BS EN ISO 3549-1 BS EN ISO 3549-2</p>
<p>The place and date of the declaration • Място и дата на декларацията • Místo a datum prohlášení • Sted og dato for erklæringen • Plaats en datum van de verklaring • Deklaratsiooni väljastamise koht ja kuupäev • Vakuutuksen paikka ja päivämäärä • Lieu et date de la déclaration • Ort und Datum der Erklärung • Τόπος και ημερομηνία δήλωσης • A nyilatkozat kelte (hely és idő) • Luogo e data della dichiarazione • Deklarācijas vieta un datums • Deklaracijos vieta ir data • Il-post u d-data tad-dikjarazzjoni • Miejsce i data wystawienia deklaracji • Local e data da declaração • Locul și data declarației • Miesto a dátum vyhlásenia • Kraj in datum izjave • Lugar y fecha de la declaración • Plats och datum för deklarationen</p>	<p>Smithco / Humboldt 1020 Hawaii Rd. Humboldt Ks. 66748 USA Feb 1, 2018</p>

Signature of the person empowered to draw up the declaration on behalf of the manufacturer, holds the technical documentation and is authorised to compile the technical file, and who is established in the Community. Подпис на човека, упълномощен да състави декларацията от името на производителя, който поддържа техническата документация и е оторизиран да изготви техническия файл и е регистриран в общността. Podpis osoby oprávněné sestavit prohlášení jménem výrobce, držet technickou dokumentaci a osoby oprávněné sestavit technické soubory a založené v rámci Evropského společenství. Underskrift af personen, der har fuldmagt til at udarbejde erklæringen på vegne af producenten, der er indehaver af dokumentationen og er bemyndiget til at udarbejde den tekniske journal, og som er baseret i nærområdet. Handtekening van de persoon die bevoegd is de verklaring namens de fabrikant te tekenen, de technische documentatie bewaart en bevoegd is om het technische bestand samen te stellen, en die is gevestigd in het Woongebied. Ühenduse registrisse kantud isiku allkiri, kes on volitatud tootja nimel deklaratsiooni koostama, kes omab tehnilisdokumentatsiooni ja kellel on õigus koostada tehniline toimik. Sen henkilöön allekirjoitus, jolla on valmistajan valtuutus vakuutuksen laadintaan, jolla on hallussaan teknisetasiakirjat, joka on valtuutettu laatimaan tekniset asiakirjat ja joka on sijoittautunut yhteisöön. Signature de la personne habilitée à rédiger la déclaration au nom du fabricant, à détenir la documentation technique, à compiler les fichiers techniques et qui est implantée dans la Communauté. Unterschrift der Person, die berechtigt ist, die Erklärung im Namen des Herstellers abzugeben, die die technischen Unterlagen aufbewahrt und berechtigt ist, die technischen Unterlagen zusammenzustellen, und die in der Gemeinschaft niedergelassen ist. Υπογραφή ατόμου εξουσιοδοτημένου για την σύνταξη της δήλωσης εκ μέρους του κατασκευαστή, ο οποίος κατέχει την τεχνική έκθεση και έχει την εξουσιοδότηση να ταξινομήσει τον τεχνικό φάκελο και ο οποίος είναι ιδιορισμένος στην Κοινότητα. A gyártó nevében meghatalmazott személy, akinek jogában áll módosítani a nyilatkozatot, a műszaki dokumentációt őrizi, engedéllyel rendelkezik a műszaki fájl összeállításához, és aki a közösségben letelepedett személy. Firma della persona autorizzata a redigere la dichiarazione a nome del fabbricante, in possesso della documentazione tecnica ed autorizzata a costituire il fascicolo tecnico, che deve essere stabilita nella Comunità. Tās personas paraksts, kura ir pilnvarota deklarācijas sastādīšanai ražotāja vērdā, kurai ir tehniskā dokumentācija, kura ir pilnvarota sagatavot tehnisko reģistru un kura ir apstiprināta Kopienā. Asmuo, kuris yra gana žinomas, kuriam gamintojas suteikė įgaliojimus sudaryti šią deklaraciją, ir kuris įpasisaršė, turi visą techninę informaciją ir yra įgaliojotas sudaryti techninės informacijos dokumentą. Il-firma tal-persuna awtorizzata li tfassal id-dikjarazzjoni fisem il-fabbrikant, għandha d-dokumentazzjoniteknika u hija awtorizzata li tikkompila l-fajl tekniku u li hija stabbilita fil-Komunità. Podpis osoby upoważnionej do sporządzenia deklaracji w imieniu producenta, przechowującej dokumentację techniczną, upoważnionej do stworzenia dokumentacji technicznej oraz wyznaczonej ds. wspólnotowych. Assinatura da pessoa com poderes para emitir a declaração em nome do fabricante, que possui a documentação técnica, que está autorizada a compilar o processo técnico e que está estabelecida na Comunidade. Semnatūra persoanei împuternicite să elaboreze declarația în numele producătorului, care deține documentația tehnică, este autorizată să compileze dosarul tehnic și este stabilită în Comunitate. Podpis osoby poverenej vystavením vyhlásenia v mene výrobcu, ktorá má technickú dokumentáciu a je oprávnená spracovať technické podklady a ktorá je umiestnená v Spoločenstve. Podpis osebe, pooblaščená za izdelavo izjave v imenu proizvajalca, ki ima tehnično dokumentacijo in lahko sestavlja spis tehnične dokumentacije, ter ima sedež v Skupnosti. Firma de la persona responsable de la declaración en nombre del fabricante, que posee la documentación técnica y está autorizada para recopilar el archivo técnico y que está establecido en la Comunidad. Undertecknas av den som bemyndigad att upprätta deklarationen å tillverkarens vägnar, innehar den tekniskadokumentationen och är bemyndigad att sammanställa den tekniska informationen och som är etablerad i gemenskapen.

2006/42/EC/Annex II
1A:10
Wayne Johnson
Technical Director
Smitcho Inc.
34 West Avenue
Wayne, PA 19087-3311
Feb 1, 2018

Certificate Number • Номер на сертификат • Číslo osvědčení • Certifikatnummer • Certificaatnummer • Sertifikaadi number • Hyväksyntänumero • Numéro de certificat • Bescheinigungsnummer • Αριθμός Πιστοποιητικού • Hitelesítési szám • Numero del certificato • Sertifikata numurs • Sertifikato numeris • Numru tač • Certificat • Numer certyfikatu • Número do Certificado • Număr certificat • Číslo osvedčenia • Številka certifikata • Número de certificado • Certifikatsnummer

75062015



The Smithco Commercial Products Two-Year Limited Warranty

Smithco, Inc. (Smithco) warrants your 2016 or newer Smithco Commercial Product (“Product”) purchased after October 1, 2016 to be free from defects in materials or workmanship for the period of time listed below. Where a warrantable condition exists, Smithco will repair the Product at no cost to you including diagnosis, labor (at the Smithco standard labor rate, subject to the Smithco flat rate schedule), and parts.

Warranty Duration Is:

1. **Two years, 1500 operational hours* from the date of delivery to the original purchaser or five years from the date of original manufacturer of the product, whichever occurs first. (*Products equipped with hour meter).**
2. **Products used in rental situations are covered for 90 days from date of delivery to original user/renter.**

Owner responsibilities:

As the Product owner, you are responsible for required maintenance and adjustments stated in your Owner's Manual. Failure to perform required maintenance and adjustments can be grounds for disallowing a warranty claim. **You are particularly responsible to train all present and future operators of this product on the safe operation of this product at your location.**

Instructions for Obtaining Warranty Service:

You are responsible for notifying the Authorized Smithco Products Distributor from whom you purchased the Product as soon as you believe a warrantable condition exists and not later than 30 days from discovery of the condition.

If you need help locating an Authorized Smithco Distributor, or if you have questions regarding your warranty rights or responsibilities, you may contact us at:

Smithco Product Support Department
Highway SS @ Poplar St.
Cameron, Wisconsin 54822
Telephone: 715-458-4192 E-Mail: ProductSupport@Smithco.com

Maintenance Parts:

Parts scheduled for replacement as required maintenance (“Maintenance Parts”), are warranted for the period of time up to the scheduled replacement time for that part.

Items/Conditions Not Covered:

Not all product failures or malfunctions that occur during the warranty period are defects in materials or workmanship. The items/conditions listed below are not covered by this warranty.



Product failures which result from the use of non-Smithco replacement parts, or from installation and use of add-on, modified, or unapproved accessories are not covered.



Product failures which result from failure to perform required maintenance and/or adjustments are not covered.



Product failures that result from operating the Product in an abusive, negligent or reckless manner are not covered.



This warranty does not apply to parts subject to consumption through use, unless found to be defective. Examples of parts which are consumed, or used up during normal Product operation include, but are not limited to: blades, tines, teeth, scarifiers, rakes, plates, wear plates, castor wheels, tires, batteries, filters, belts, nozzles, etc.



This warranty does not apply to failures caused by outside influence. Items considered to be outside influence include, but are not limited to, weather, storage practices, contamination, use of unapproved coolants, lubricants, additives, or chemicals, etc.



This warranty does not apply to normal "wear and tear" items. Normal "Wear and Tear" includes, but is not limited to, damage to seats due to wear or abrasion, worn painted surfaces, scratched decals or windows, etc.



Smithco may require the return of failed parts or components in order determine the validity of any warranty claim.



Smithco will not be obligated to replace components of other manufacturers if inspection by the original component manufacturer indicates that failure was due to normal wear and tear, expected consumption through use or improper care or service.

Other Legal Disclaimers:

The above remedy for product defects through repair or replacement by an authorized Smithco distributor or dealer is the purchaser's sole remedy for any defect. This warranty gives you specific legal rights, and you may also have other rights which vary from state to state.

THERE ARE NO OTHER EXPRESS WARRANTIES OTHER THAN THOSE SET FORTH ABOVE. ALL IMPLIED WARRANTIES OF MERCHANTABILITY AND FITNESS FOR USE ARE LIMITED TO THE DURATION OF THE LIMITED WARRANTIES CONTAINED HEREIN.

Some States may not allow limitations on how long an implied warranty lasts, so the above limitation may not apply to you.

THE SMITHCO COMPANY IS NOT LIABLE FOR INDIRECT, INCIDENTAL OR CONSEQUENTIAL DAMAGES IN CONNECTION WITH THE USE OF THE PRODUCT, INCLUDING ANY COST OR EXPENSE OF PROVIDING A SUBSTITUTE PRODUCT OR SERVICE DURING PERIODS OF MALFUNCTION OR NON-USE.

Some states may not allow the exclusion of indirect, incidental or consequential damages, so the above exclusion may not apply to you.

Smithco neither assumes, nor authorizes any person to assume for it, any other liability in connection with the sale or use of this product.

**SMITHCO, INC.
WANYE, PA 19087**

