



## *Operator's Manual*

Wayne, PA 19087

[www.smithco.com](http://www.smithco.com)

# **Super Star "E" 48V**

## **8440 & 8450**

**SN: EM770**

**Revised May, 2013**

*Product Support:*

1020 Hwy 224; Humboldt, KS 66748  
1-888-422-5173 [lj@smithco.com](mailto:lj@smithco.com)

# **TABLE OF CONTENTS**

<b><i>TITLE</i></b>	<b><i>PAGE</i></b>
Introduction	1
Safe Practices	2
Symbols	3-5
8440 & 8450 Specifications	6
Setup	7
Section 1: General	8-11
Section 2: Servicing – Safety Procedures	12
Section 3: Servicing the Brakes	13-18
Section 4: Installation and Servicing the Batteries	19-21
Section 5: Battery Charger	22-27
Section 6: Electric Motor	28-36
Fault Finding	37-38

## INTRODUCTION

Thank you for purchasing a **SMITHCO** product.

Read this manual and all other manuals pertaining to the Super Star 48V carefully as they have safety, operating, assembly and maintenance instructions. Failure to do so could result in personal injury or equipment damage.

Keep manuals in a safe place after operator and maintenance personnel have read them. Right and left sides are from the operator's seat, facing forward.

All **SMITHCO** machines have a Serial Number and Model Number. Both numbers are needed when ordering parts. The serial number plate on the Super Star E 48V is located on the left, rear main frame.

For easy access record your Serial and Model numbers here.

<b>SMITHCO</b>		DATE OF MFG.	
WAYNE, PENNSYLVANIA 19087 USA 610-688-4009 Fax 610-688-6069		<input type="text"/>	
SERIAL NO.	<input type="text"/>	kW/hp	<input type="text"/>
MODEL NO.	<input type="text"/>	kg/lb	<input type="text"/>

This Operation and Service Manual has been designed to enable you to maintain and service this vehicle.

Proper service, repair and maintenance are important for safe, reliable operation. If part replacement is necessary, please **NOTE** the use of all non-SMITHCO parts will void your warranty.

This Manual contains various **NOTES**, **CAUTIONS**, and **WARNINGS** that must be carefully observed in order to reduce the risk of personal injury during operation or repair.

Information needed when ordering replacement parts:

1. Model Number of machine
2. Serial Number of machine
3. Name and Part Number of part
4. Quantity of parts

## **SAFE PRACTICES**

1. It is your responsibility to read this manual and all publications associated with this machine (accessories and attachments).
2. Never allow anyone to operate or service the machine or its attachments without proper training and instructions. Never allow minors to operate any equipment.
3. Learn the proper use of the machine, as well as the location and purpose of all the controls and gauges before you operate the equipment. Working with unfamiliar equipment can lead to accidents.
4. Wear all the necessary protective clothing and personal safety devices to protect your head, eyes, ears, hands and feet. Operate the machine only in daylight or in good artificial light.
5. Inspect the area where the equipment will be used. Pick up all debris you can find before operating. Beware of overhead obstructions and underground obstacles. Stay alert for hidden hazards.
6. Never operate equipment that is not in perfect working order or that does not have decals, guards, shields, or other protective devices in place.
7. Never disconnect or bypass any switch.
8. This machine demands your attention. To prevent loss of control or tipping of the vehicle:
  - A. Use extra caution in backing up the vehicle. Make sure area is clear.
  - B. Do not stop or start suddenly on any slope.
  - C. Reduce speed on slopes and during sharp turns. Use caution when changing directions on slopes.
  - D. Stay alert for holes in the terrain and other hidden hazards.
9. Before leaving operator's position for any reason:
  - A. Disengage all drives.
  - B. Lower all attachments to the ground.
  - C. Set park brake.
  - D. Shut off unit and remove the ignition key.
10. Keep hands, feet and clothing away from moving parts. Wait for all movement to stop before you clean, adjust or service the machine.
11. Never carry passengers.
12. Shut unit off before making repairs/adjustments or checking/adding oil to the rear axle.
13. Use parts and materials supplied by SMITHCO only. Do not modify any function or part.
14. When running the machine downhill with your foot on the accelerator pedal, the machine will reach a maximum of 10 mph (16 kph). However, if you remove your foot from the accelerator pedal when going downhill, the machine will only travel at a maximum of 5 mph (8kph). This is called "Plug Braking."

These machines are intended for professional maintenance on golf courses and baseball fields. Other use is forbidden.

**SYMBOLS**

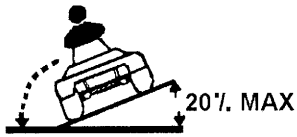

**GRADE**



**NO RIDER**

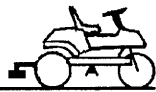

**RAKE  
UP / RAISE**

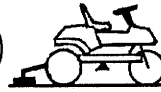

**RAKE  
DOWN / LOWER**



**ELECTRICAL  
POWER**



**NO ELECTRICAL  
POWER**



**PINCH POINT**



**WARNING  
DANGER  
CAUTION**



**CULTIVATOR  
SCARIFIER  
UP / RAISE**



**CULTIVATOR  
SCARIFIER  
DOWN / LOWER**

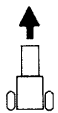

**FOWARD**

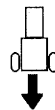









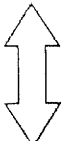
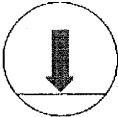
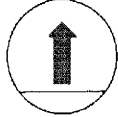

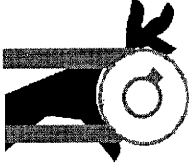
**REVERSE**

# SYMBOLS

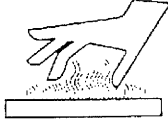
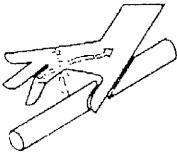
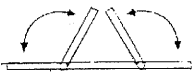
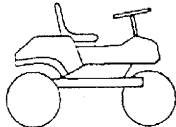
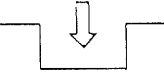
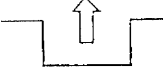
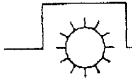
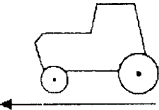
	Read Operator's Manual		Electrical Power		No Electrical Power
	Engine - Stop		Engine - Start		Engine - Run
	Engine Oil		Temperature Light		Water Temperature
	RPM 1000/mi		Gasoline		Diesel
	Glow Plug - On		Glow Plug - Off		Glow Plug
	Hour Meter		Hour Meter		Fuse
	Hand Throttle		Choke - Closed		Choke - Open
	Park Brake		Park Brake Release		Hydraulic Oil Level

# SYMBOLS

	Up/Down Arrow		Down/Lower		Up/Raise
	No Smoking		Moving Parts		Manual Operation
	Pinch Point		Step		Hot Surface
	Hydraulic Fluid Penetration		Lift Arm		Tractor
	Engage		Disengage		PTO
	Ground Speed		Fast		Slow
<b>H</b>	High	<b>L</b>	Low	<b>F</b>	Forward
<b>R</b>	Reverse	<b>N</b>	Neutral		Warning Danger Caution

## **8440 & 8450 E-STAR 48V SPECIFICATIONS**

### **WEIGHTS AND DIMENSIONS**

Length 65" (165cm)  
Width 56" (142cm)  
Height 49" (124cm)  
Weight 925 lbs. (420kg)

### **SOUND LEVEL**

At ear level 50 dB  
At 3 ft. (0.914m) 40dB  
At 30 ft. (9.14m) 20dB

### **MOTOR (DC SEPARATELY EXCITED)**

48 Volt  
S2-60 minute EE Rating  
10.0 ft / lbs  
2400 rpm  
84 amps (Armature)  
10 amps (Field)  
4.5 hp (3.375)  
Class H insulation (180 degree Celsius)

### **TIRES AND WHEELS**

(3) 21 x 11.00 x 8 NHS 5 psi (.35 bar)

### **SPEED**

Forward Speed 0-10 mph (0-16 kph)  
Reverse Speed 0-5 mph (0-8 kph)

### **BATTERIES**

J185H – AC 12 volt  
225 AH  
20 HR  
185 AH@5 HR  
Length 15" (38cm)  
Width 7" (17.78cm)  
Height 14.5" (36.83cm)  
Weight 125lbs (56.81 kg)



## SETUP

The Bunker Rakes arrive from SMITHCO with some assembly required before service.

1. Remove banding holding unit down. Set Park Brake.
2. To mount wheels block front wheel and jack up the rear of machine being careful not to damage underside of machine. Place wheel on hub, lining up bolt holes. Use the eight lug nuts provided. Then torque to 64-74 ft/lb (87-100 nm) using a cross pattern. Retorque after first 10 hours and every 200 hours thereafter. Lower machine to ground and remove blocks and jack.
3. Check tire pressure. The tire pressure should be 5 psi (0.49 Bar)
4. Place Key (Ref #2) into steering shaft (Ref #1).
5. Install Steering Wheel (Ref #3) onto the steering shaft (Ref #1) and secure using nut (Ref #4). Cover with cap (Ref #5).
6. Install seat.

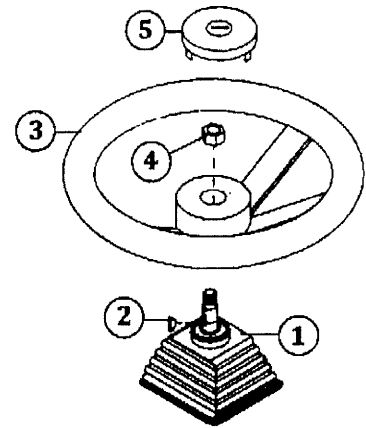

### WARNING

**Connecting battery cables to the wrong post could result in personal injury and/or damage to the electrical system. Make sure battery and cables do not interfere with or rub on any moving part. Connect black and white negative (-) cables to the battery first. Then positive (+) cables can be connected.**

7. Check oil level in axle on SUPER STAR 48V. The level can be checked by jacking up right side of unit, until tire is five inches off floor. Then remove plug from oil pan on rear axle. The oil should run out. If there is no sign of oil, then add oil until it begins to run out. Use 10W40 motor oil. A new axle takes 20 oz. of oil. Oil should be changed in rear axle once a year.
8. Machine should be greased before using.
9. Read operating instructions before using machine.

## **SECTION 1: GENERAL**

### **CONTROLS**

The controls of the vehicle consist of a Key Switch, Forward-Reverse Switch, Accelerator Pedal, Service Brake and Parking Brake.

### **KEY AND RUN SWITCH**

This switch enables the basic electrical system of the vehicle to be turned on or off by turning the key. Use Key Switch to turn off system when working on unit or when storing unit. Regenerative brake system does not work when switch is turned off.

For added security, when the vehicle is left unattended the key must be removed to prevent inadvertent operation of the vehicle.

### **NOTE**

To avoid damage, the vehicle must be brought to a complete stop before moving the forward-reverse switch.

### **ACCELERATOR PEDAL**

Release the Parking Brake before depressing the accelerator. If this procedure is not followed, the brakes will burn out.

Depressing the vehicle Accelerator Pedal starts the motor. Each time the pedal is released, the motor will stop.

## HOW TO RAKE A SAND TRAP

View bunker to determine the most efficient pattern to follow so that rake pattern and configuration of bunker will flow in same general direction and look attractive.

Enter bunker at its lowest point. Perhaps drain area or another point where the "lip" of the trap is minimal.

Operate at 2 - 4 mph (3 - 6.5 kph) for best raking results. Control speed with hydraulic pedal.

Once fully inside bunker, lower rear rake and proceed forward as described above.

First pass should be directly down center of trap. This helps avoid extremely sharp turns that will spoil sands' appearance. Once at far end, turn machine and drive down one side of trap and come back up other side.

Grass or other material may build up on rake tines as machine passes "enter/exit" point in Figure 1. Lift rake briefly while still moving forward.

Do not rake closer than 6" (15 cm) to edge of trap.

Do not rake slopes in trap. The weight of machine will pull sand down.

Use cultivator or other center mounted accessories only as necessary for compacted sand. Frequent use will leave sand too soft and objectionable to some golfers.

Use front mounted plow to push sand to desired locations within trap.

After exiting trap, secure machines in accordance with practices described in this manual. Rake trap edges, slopes and "enter/exit" area with a hand rake.

After returning to maintenance area, thoroughly clean machine, check fluids, and lubricate as advised in this manual.

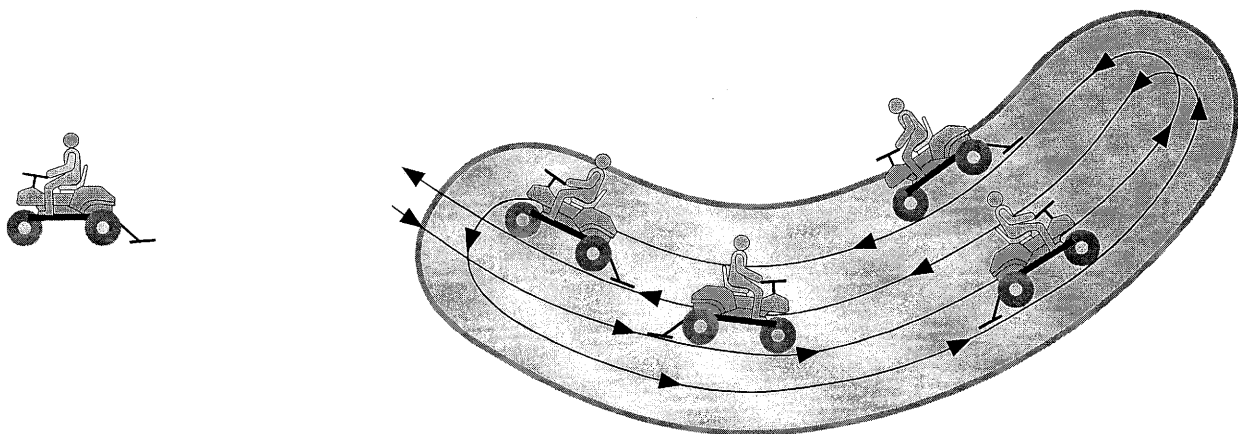

## **BEFORE STARTING**

Be sure you understand the vehicle, its equipment, and how to use it safely. Although this vehicle has been designed to be safe and reliable, maintaining its good performance depends to a large extent on the operator.

### **!!! CAUTION !!!**

**IMPROPER USE OR OPERATION OF THE VEHICLE OR THE LACK OF PROPER MAINTENANCE WILL RESULT IN DECREASED PERFORMANCE OR DAMAGE TO THE VEHICLE.**

### **!!! WARNING !!!**

**WHEN THE VEHICLE IS TO BE LEFT UNATTENDED, TURN KEY TO "OFF" POSITION, REMOVE KEY AND ENGAGE PARKING BRAKE.**

**DRIVE THE VEHICLE ONLY AS FAST AS TERRAIN AND SAFETY CONSIDERATIONS ALLOW. CONSIDER THE TERRAIN AND EXISTING TRAFFIC CONDITIONS. ALSO, CONSIDER THE ENVIRONMENTAL FACTORS WHICH AFFECT THE TERRAIN AND YOUR ABILITY TO HANDLE THE VEHICLE.**

**AVOID DRIVING FAST DOWNHILL. SUDDEN STOPS OR CHANGE OF DIRECTION MAY RESULT IN A LOSS OF CONTROL. USE BRAKE TO CONTROL SPEED WHEN TRAVELING DOWN AN INCLINE.**

**USE EXTRA CARE WHEN DRIVING THE VEHICLE ACROSS AN INCLINE.**

**MAKE SURE THAT FORWARD- REVERSE SWITCH IS IN CORRECT POSITION BEFORE ATTEMPTING TO START VEHICLE.**

**SLOW DOWN BEFORE AND DURING TURNS. ALL TURNS SHOULD BE EXECUTED AT REDUCED SPEED.**

## **STARTING**

To start the electric vehicle; apply the Parking Brake; place the key in the ignition switch and turn to the "ON" position; move Forward-Reverse Switch to the direction desired; release Parking Brake and depress the Accelerator Pedal to start the motor.

### **NOTE**

**When the Accelerator Pedal is released, the motor stops. To stop the vehicle more quickly, depress *THE BRAKE PEDAL*.**

**When leaving the vehicle unattended, engage the Parking Brake.**

# **GENERAL MAINTENANCE PROCEDURES**

## **DAILY**

1. Examine vehicle for damage or anything unusual to normal wear and tear.
  - Be sure that the engaged Parking Brake will hold on a hill and that when disengaged, does not drag or prevent the vehicle from rolling freely.
  - Tire condition should be inspected on a daily basis. Recommended pressure is 5lbs. For all tires and is listed in the Specifications Section. Inflation pressures should be checked on a weekly basis when the tires are cool.
  - Assure that all switches are operating normally.
  - Listen for any noises, such as rattles due to loose hardware; scraping sounds, brakes dragging, or unusual motor noises. Be sensitive to abnormal performance.
  - Inspect all lubrication areas around pedal shafts, chassis parts, etc.
2. Wash accumulated dirt **daily** from motor compartment and under-body.

## **50 HOUR MAINTENANCE**

- **STEERING:** Assure that all mounting bolts are securely in place. Inspect for abnormal play in steering shaft and/or steering wheel.
- **BRAKES:** Inspect for wear or unusual scratches on brake shoes and brake drums and linkages
- **WHEELS AND TIRES:** Inspect for proper tire pressure, abnormal wear, cracks or damage to tread area, tightness of lug nuts, dented or damaged wheels.
- **BATTERIES:** Check for low electrolyte and corrosion build-up.
- **WIRING:** Inspect all wiring for loose connections or cracked and/or worn insulation.
- **FORWARD-REVERSE SWITCH:** Check for wear.
- **ACCELERATOR SWITCH:** Check for wear and lubricate.
  
- **SOLID STATE SPEED CONTROL:** Check for dirt and corrosion and clean terminals.
  
- **MOTOR BRUSHES:** Check with gauge.

## **100 HOURS MAINTENANCE**

- Perform **50 Hour Maintenance**.
- Check the differential oil level.
- Lubricate all moving linkages.

**NOTE: If these instructions are not followed, the warranty will be denied.**

## **SECTION 2: SERVICING - SAFETY PROCEDURES**

### **WHEN SERVICING**

**!!! WARNING !!!**

SET THE PARKING BRAKE.

DO NOT WORK ON THE MOTOR WHILE CONNECTED TO BATTERIES.

KEEP SMOKING MATERIALS, FLAME OR SPARKS AWAY FROM THE BATTERIES.

NEVER CONNECT OR DISCONNECT EITHER THE BATTERIES OR ANY ELECTRICAL COMPONENT WHILE THE KEY IS IN THE SWITCH.

WHEN CONNECTING THE BATTERY CABLES, PAY PARTICULAR ATTENTION TO THEIR POLARITIES. NEVER CONFUSE THE POSITIVE POSTS WITH THE NEGATIVE POSTS.

**!!! WARNING !!!**

USE INSULATED WRENCHES AND BE CAREFUL NOT TO ALLOW WRENCHES TO CONTACT METAL AREAS OF VEHICLE WHILE WORKING ON BATTERY TERMINALS, OBSERVE BATTERY POLARITY WHEN REINSTALLING CABLES.

**Using an insulated wrench, remove all wires from the vehicle batteries. Wrapping a wrench with electrical tape will work, making sure no bare metal is showing. (Figure 1)**

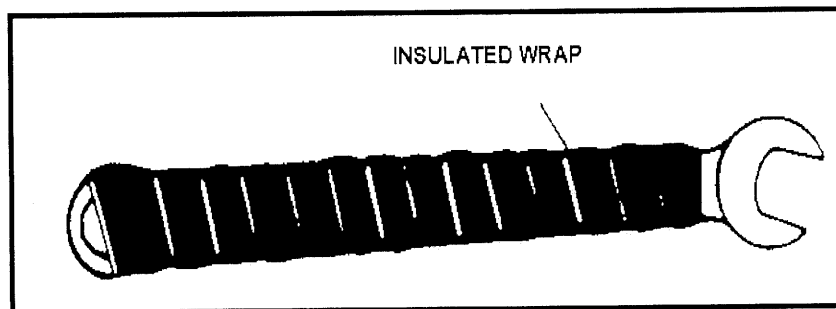

**FIGURE 1 INSULATED WRAP**

**Remove the batteries using a battery carrying tool.**

**!!! WARNING !!!**

BATTERIES ARE HEAVY AND CARE SHOULD BE TAKEN WHEN REMOVING THEM. BE CAREFUL TO LIFT BATTERIES WITHOUT TIPPING THEM; ELECTROLYTE MAY BE SPILLED WHICH COULD CAUSE BURNS OR DAMAGE TO VEHICLE AND CLOTHING. SHOULD ANY ELECTROLYTE BE SPILLED FLUSH THOROUGHLY WITH WATER. BE SURE TO WEAR EYE PROTECTION.

## **SECTION 3: SERVICING THE BRAKES**

### **NOTE**

To assure proper braking performance, all periodic maintenance inspections and procedures should be performed as indicated in SECTION 1.

### **GENERAL**

The overall brake system consists of:

- (a) Self-adjusting wheel brake units normally do not require adjustment until internal components have worn to a point of needing replacement.
- (b) Actuating linkages requiring periodic adjustment to compensate for normal wear of system components and/or their replacement.

### **NOTE**

A complete brake system adjustment procedure must be performed whenever any part of the brake system has been replaced.

### **DAILY BRAKING PERFORMANCE TEST**

To determine the adequacy of the vehicle's brake system, the following test should be performed daily:

### **!!! WARNING !!!**

**ALL DRIVING BRAKE TESTS MUST BE DONE IN A SAFE LOCATION WITH REGARD FOR THE SAFETY OF ALL PERSONNEL.**

The recommended way of performing the daily brake test and determining any vehicle that has unacceptable braking performance is to have personnel handling the vehicle, latch the brake at a common point on a paved surface, while traveling at maximum governed speed. The vehicle stopping location must be observed, and the vehicle that stops in a significantly greater distance than another acceptable vehicle should immediately be removed from service and inspected by a qualified mechanic.

The mechanic should perform a "Panic" stop on the suspect vehicle by applying maximum force and travel to the Brake Pedal while traveling at full speed. He should observe if either of the rear wheels fails to "Lock up." If one wheel fails to lock, it is reasonable to expect that a problem exists with the service brake system and the 50 Hour Maintenance must be performed in its entirety. If both wheels lock, the Parking Brake must be adjusted and the vehicle retested per the Daily Brake Test.

## INSPECTION OF BRAKE SHOES

!!! WARNING !!!

WEAR PROTECTIVE GOGGLES AND MASK WHEN CLEANING BRAKE COMPONENTS. LUBRICATE AREA INDICATED (FIGURE 4) WITH COMMERCIALLY AVAILABLE BRAKE COMPONENT LUBRICANT (available from any auto parts outlet).

The pattern of normal brake shoe wear is shown (Figure 3) in quadrants A, B, C and D with Quadrant 'A' showing the most wear; 'B' will show the second most wear. Quadrants B and D will always be to the rear of the vehicle.

Inspect brake shoes. Brake shoes **MUST** be replaced as a set when either shoe has a lining thickness less than .040 in. thick **AT ANY POINT ON THE SHOE**.

After lubricating the backing plate and adjuster mechanism at the lubrication points shown in the Illustration (Figure 4), reassemble and adjust the complete brake system according to the procedures outlined later in this Section.

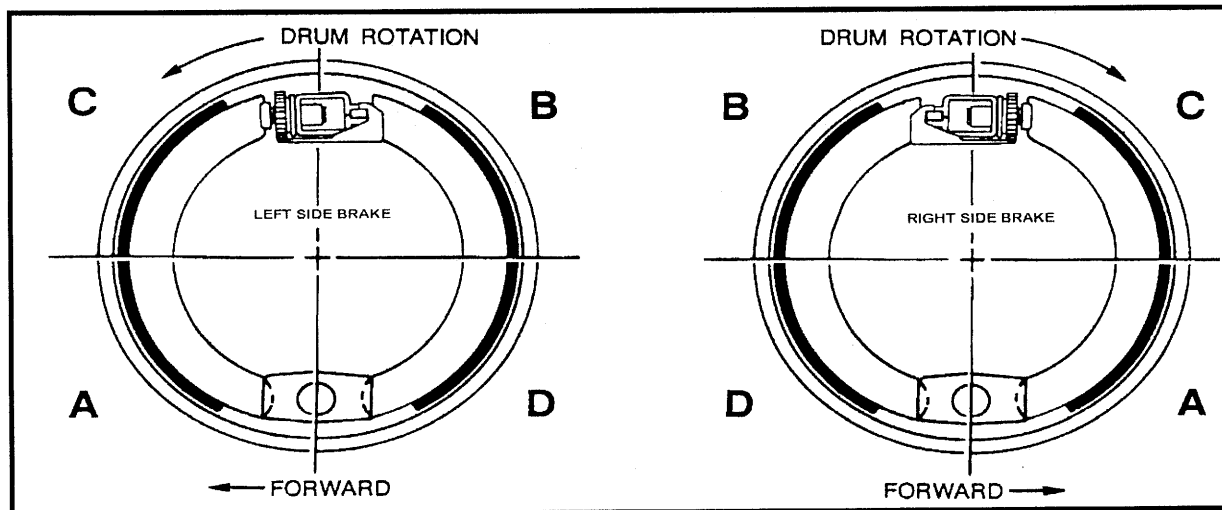

FIGURE 3 BRAKE WEAR

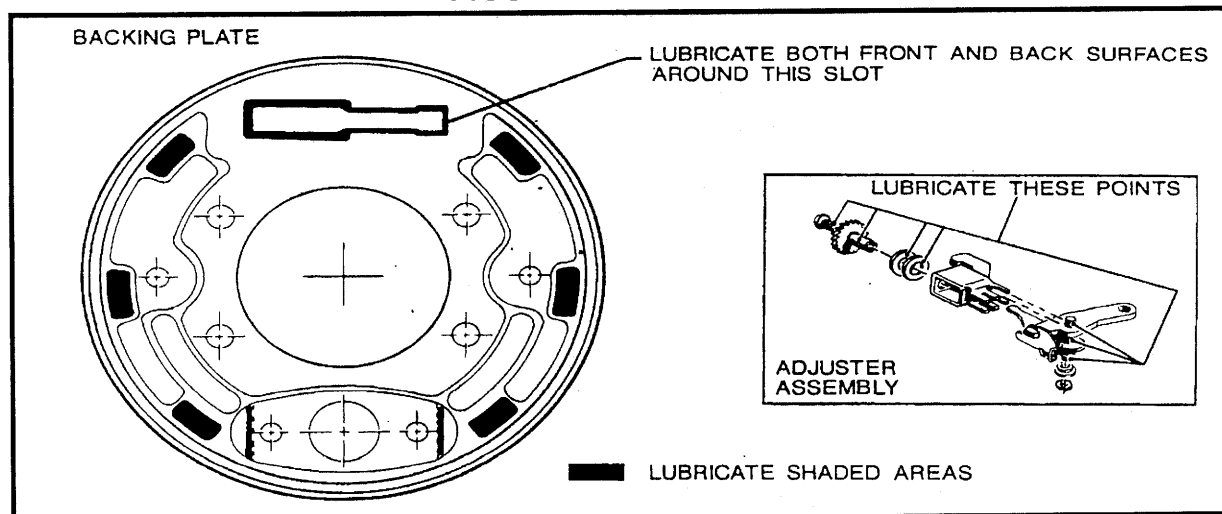

FIGURE 4 BRAKE LUBRICATIONS AREAS



## **BRAKE SHOE REMOVAL**

Using a pair of pliers (see Figure 5, page 14) compress the brake shoe retainer springs (1) at the open end of the spring.

While holding the tension pin (2) with a second set of pliers, turn the retainer spring 1/4 turn to align the slot in the spring retainer with the flats in the tension pin. Remove the brake shoe retainer springs.

Grasp the brake shoes (3) in the center and tilt them outwards and away from the back mounting plate. This will release the tension in the brake springs (4). Remove the brake springs and remove the brake shoes.

Inspect brake shoes. If a brake shoe has less than .040 in. lining material thickness AT ANY POINT on either shoe then both shoes MUST be replaced.

Check for free lateral (front and back) movement of the adjusting mechanism and for free movement of the 'star' wheel 2 (Figure 4A, page 13). Remove the boot on the brake lever (Figure 6, page 14). Clean any accumulated brake dust from the backing plate and adjuster mechanism using a brush or air hose (Figure 6, page 14).

If the brake is being removed for an axle bearing and seal replacement, the four bolts and nuts securing the brake backing plate assembly to the rear axle must be removed. When reinstalling the brake mounting bolts, tighten to 23-35 ft. lb. torque.

### **REPLACING BRAKE SHOES (See Figure 6, page 14)**

#### **NOTE**

The metal portion of the brake shoes differs between front and rear shoes. The identical ends of the shoes fit against the fixed anchor at the top of the brake. The shoe with the straight end engages in the slot in the adjusting screw, while the triangular ended shoe engages in the rear of the adjusting mechanism.

The springs must be inserted with the light spring at the top. The long hook is installed down through the rear brake shoe. The heavier bottom spring is installed with the spring hooks facing up.

Install the brake shoes using the reverse order of disassembly and secure with the brake shoe retainer springs and brake shoe return springs.

Clean the axle shaft to remove grease, dirt and all foreign matter. Apply a small amount of lubricant (Neverseize) to the spline.

Insert a straight blade screwdriver between the adjusting lever and the adjusting mechanism. Rotate the star wheel counter-clockwise until the shoes have retracted sufficiently to permit the brake drum to be installed. Install washer (5), brake drum (4), washer (3), and tighten the axle nut (2) to 70 ft. lb. torque minimum.

If the slot in the axle nut and the hole in the axle are not in alignment, continue to tighten the axle nut until the alignment is achieved.

## **BRAKE SHOE REMOVAL (Continued)**

### **NOTE**

Minimum torque is 70 ft. lb. Torque readings of up to 140 ft. lb. are satisfactory.

Install new cotter pin (1).

Move the brake lever forward and release fully; repeat until the travel of the lever is approximately 1/8 inch. Install brake cables using clevis pin (13) and a new cotter pin (14).

### **COMPENSATING BRAKE LINKAGE ADJUSTMENT (FIGURE 4B, PAGE 15)**

1. Raise the vehicle axle off the ground and engage the Parking Brake.
2. Check the position of the equalizer (1) as shown in Detail A.
3. Remove wheel and tire from side needing adjusting.
4. Disengage Parking Brake. Loosen Rod Nut (5), then loosen tension on Yoke, (2).
5. Disconnect compensating Linkage from equalizer by removing Cotter Pin (3) from Clevis Pin (4). Then remove Clevis Pin (4) from equalizer (1).
6. Next remove Cotter Pin (5) and Clevis Pin (6) from brake lever of side to be adjusted.
7. Using a suitable tool, (a hammer handle works well), push the brake lever forward and release fully, as shown in Figure 4A, Page 13, Detail B. Repeat as needed until the lever travel is approximately 1/8 inch.
8. Reconnect everything by reversing disconnecting procedures.

### **NOTE**

Always use new Cotter Pins, when reconnecting Clevis Pins.

**FIGURE 4A**

**ILLUSTRATIONS SHOW LEFT SIDE BRAKE ONLY. RIGHT SIDE IS MIRROR IMAGE.**

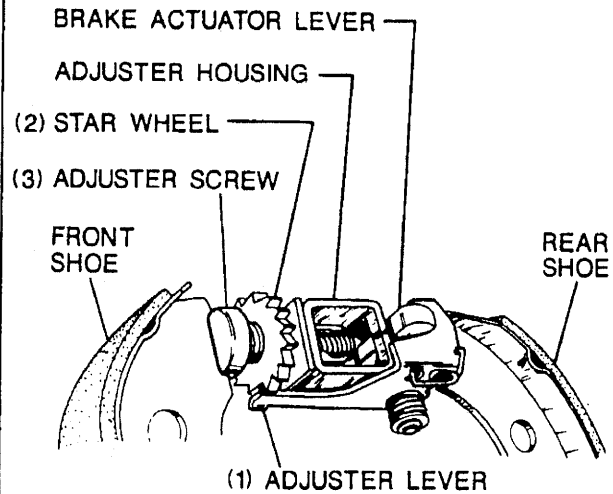
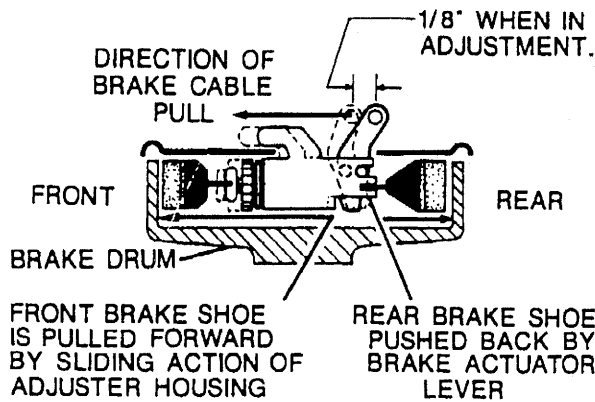

**NOTE: TEETH ARE NUMBERED IN ILLUSTRATION TO CLARIFY THEIR POSITIONS.**

THE DISTANCE OF THE ADJUSTER LEVER TRAVEL IS REGULATED BY THE AMOUNT OF BRAKE SHOE WEAR.(A)

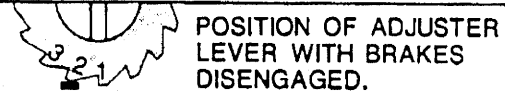

**A**

WHEN BRAKE SHOE WEAR IS MINIMAL, THE DISTANCE OF ADJUSTER LEVER TRAVEL IS TOO SHORT TO FULLY RE-ADJUST BRAKES.(B)

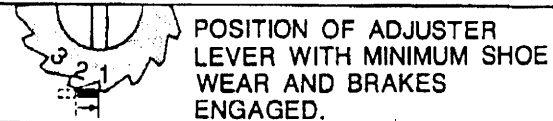

**B**

AS SHOE WEAR INCREASES, ADJUSTER LEVER TRAVEL INCREASES, THUS TURNING THE STAR WHEEL.(C)

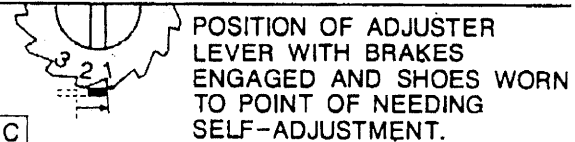

**C**

WHEN BRAKE SHOES HAVE WORN SUFFICIENTLY TO REQUIRE RE-ADJUSTMENT, THE ADJUSTER LEVER ADVANCES AND RATCHETS TO THE NEXT TOOTH WHEN BRAKES ARE RELEASED.(D)

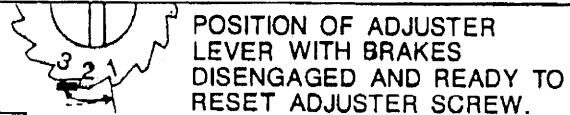

**D**

WHEN BRAKE IS NEXT ENGAGED, THE ADJUSTER LEVER WILL ROTATE THE STAR WHEEL FAR ENOUGH TO EXTEND THE ADJUSTER SCREW, THUS RE-SETTING THE PROPER SHOE/DRUM CLEARANCE.(E)

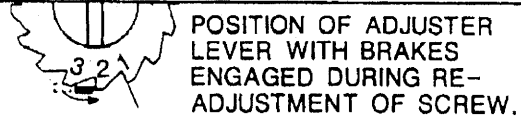

**E**

WHEN THE SHOE/DRUM CLEARANCE IS RESET, LESS EFFORT IS REQUIRED TO ENGAGE THE BRAKES, THUS THE ADJUSTER LEVER TRAVEL IS ONCE AGAIN REDUCED.(F,A)

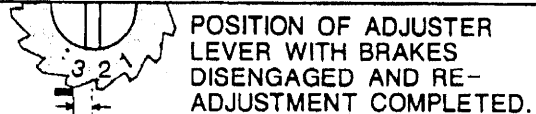

**F**

**NOTE NEW POSITIONS OF TEETH.**

**HOW THE BRAKE ADJUSTER WORKS**

# COMPENSATING BRAKE LINKAGE ADJUSTMENT

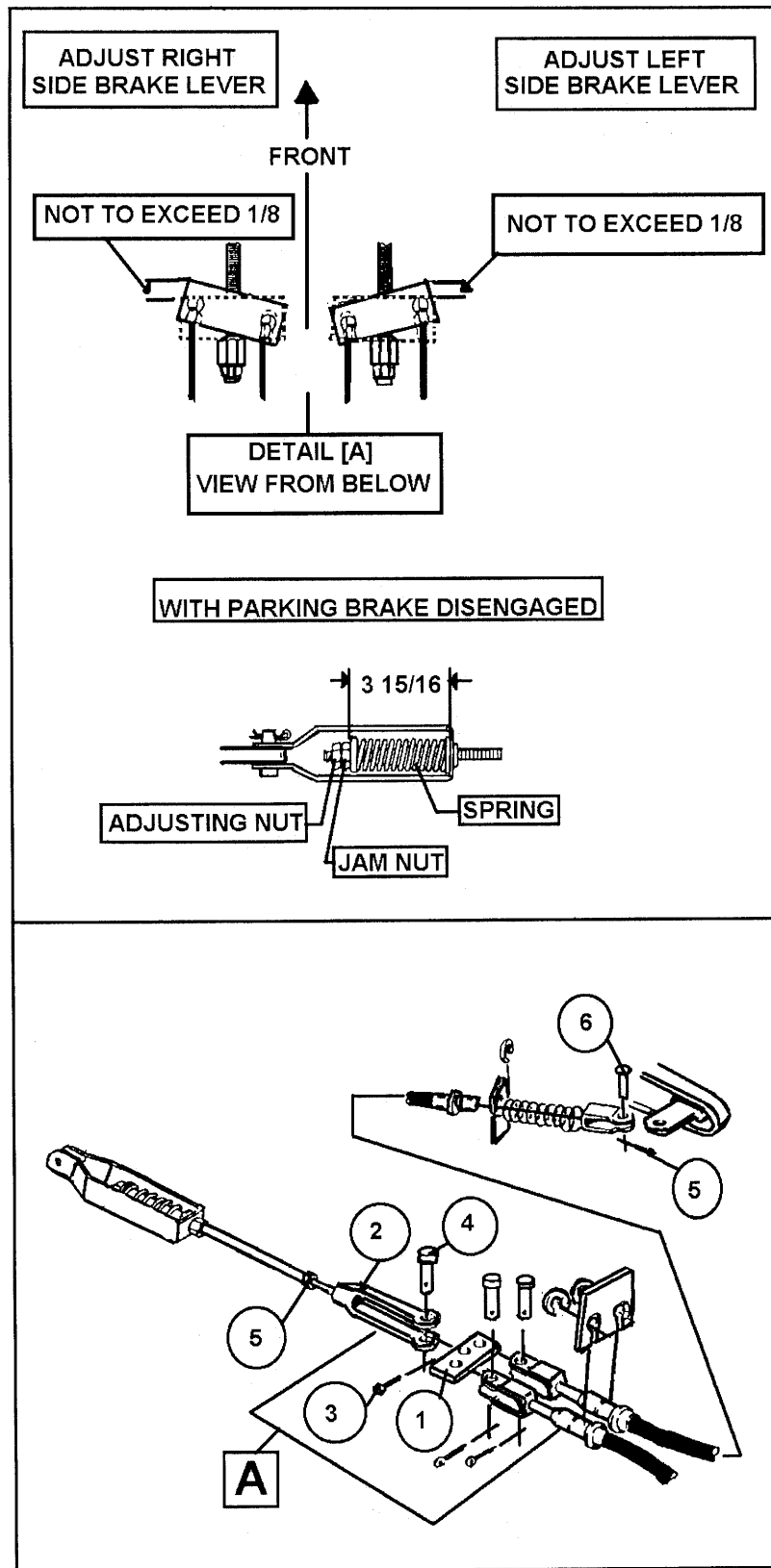

FIGURE 4 B

## **SECTION 4: INSTALLATION AND SERVICING THE BATTERIES**

Electric vehicle batteries require CAREFUL maintenance to maximize their useful service life.

### **!!! CAUTION !!!**

**OVERFILLING BATTERIES WILL VOID THE WARRANTY. WE SUGGEST THE USE OF AN AUTOMATIC WATERING DEVICE THAT IS AVAILABLE FROM YOUR BATTERY DISTRIBUTOR.**

### **!!! WARNING !!!**

**HYDROGEN GAS IS FORMED WHEN CHARGING BATTERIES. DO NOT CHARGE BATTERIES WITHOUT ADEQUATE VENTILATION. DO NOT SMOKE IN AN AREA BEING USED FOR CHARGING BATTERIES. CONCENTRATIONS OF 4% HYDROGEN GAS OR MORE IS EXPLOSIVE.**

## **PREVENTIVE MAINTENANCE**

- Batteries must be recharged after each day's use. See battery charging, page 19.
- Check the electrolyte level at LEAST once a week.
- Inspect all wiring for breaks or deterioration of the insulation.
- Before charging batteries, inspect all terminals for frayed conductors and loose or damaged connectors.
- Before charging batteries, inspect all terminals to assure that they are both clean (corrosion free) and securely fastened to battery posts.
- Batteries should be checked frequently to be sure that they are in a good state of charge. Full charge for a new battery should yield a hydrometer reading of 1.260-1.280 specific gravity while an older battery may give a reading of 1.250 specific gravity and still be fully charged.
- When adding water, do not overfill. Overfilling will cause a loss of acid from the electrolyte. Use distilled water when adding water to batteries. We recommend that other water sources NOT be used since impurities can reduce the useful life of the batteries.
- To prevent unnecessary drag on the vehicle, which will result in poor performance and a higher amperage draw, inspect for improperly adjusted wheel bearings, dragging brakes, and under-inflated tires.
- In the "off season," the batteries should be FULLY CHARGED and stored in an unheated, covered area. Check the batteries during the "off season" at thirty-day intervals and recharge if a hydrometer shows a reading of less than 1.220 specific gravity.

**!!! CAUTION !!!**

**DO NOT SEND A VEHICLE OUT UNLESS ITS BATTERIES ARE IN A GOOD STATE OF CHARGE. DISCHARGING A BATTERY COMPLETELY BEFORE RECHARGING (DEEP CYCLING) IS DETRIMENTAL TO BATTERY LIFE.**

**!!! WARNING !!!**

**WEAR GLOVES AND EYE PROTECTION WHEN WORKING WITH BATTERIES. ACID IN THE ELECTROLYTE CAN CAUSE BURNS TO THE EYES, SKIN AND CLOTHING.**

**BATTERY INSTALLATION: NEW OR REPLACEMENT**

**!!! WARNING !!!**

**BEFORE PROCEEDING, REMOVE ALL JEWELRY, RINGS, WATCHES, ETC., AND WRAP ALL WRENCHES IN VINYL INSULATING TAPE (FIGURE 1, PAGE 5) TO ELIMINATE THE POSSIBILITY OF A SHORT CIRCUIT SHOULD THE OPPOSING TERMINALS BE "SHORTENED OUT" OR CONTACTED TO THE FRAME. A SHORT CIRCUIT COULD RESULT IN AN EXPLOSION AND SEVERE PERSONAL INJURY. BE SURE THAT THE KEY AND RUN, TOW/MAINTENANCE SWITCH IS "OFF."**

See Safety Procedures in Section 2, page 8. When replacing batteries carefully note the manner in which the old set of batteries were installed. Pay particular attention to the polarity of the wiring.

Remove the wiring from each battery using an *INSULATED WRENCH* (Figure 1, page 8).

**!!! WARNING !!!**

**BATTERIES ARE HEAVY AND CARE SHOULD BE TAKEN WHEN REMOVING THEM. BE CAREFUL TO LIFT BATTERIES WITHOUT TIPPING THEM, ELECTROLYTE MAY BE SPILLED WHICH COULD CAUSE BURNS OR DAMAGE TO VEHICLE AND CLOTHING. SHOULD ANY ELECTROLYTE BE SPILLED, FLUSH THOROUGHLY WITH WATER.**

Inspect the battery racks for corrosion and clean if required using a putty knife and a wire brush. Remove ALL corrosion before priming and painting with a corrosion resistant paint.

Inspect all batteries visually for damaged containers, covers or terminals that may have been damaged or broken during transit. Inspect each cell (a dry cell could indicate a possible crack in the battery case).

Inspect all cables and terminals for any defects and replace as required. If they are to be reused, clean in a solution of water and bicarbonate of soda (1 bucket water to 1 cup of bicarbonate of soda). Rinse thoroughly and clean and dry. Remove any remaining corrosion from the wire terminals using a wire brush. Clean battery terminals with a wire brush until all corrosion is removed.

Use an insulated wrench to install the battery wiring and tighten nuts to provide a tight connection between the wire terminals and the battery posts.

Apply a coat of petroleum jelly to the outside of the connection to retard corrosion of the joint.

Before the vehicle is put into service for the first time with new batteries, a 12-hour charge is required to charge all batteries to a common level of charge.

**NOTE**

**When vehicles are used for a long period of time, the batteries can become deeply discharged, Batteries in this state of discharge require longer charge cycles to restore their full capacity.**

If this lengthy charge time is prematurely terminated because the vehicle is returned to service, the balance of the charge should be made up. This make up or catch up charge should be accomplished at the earliest possible time. If the recharge is not made up, the batteries become more and more discharged as they are used.

## **SECTION 5: BATTERY CHARGING**

It is most important to follow the following steps when charging batteries.

- Check that electrolyte covers the plates in ALL cells.
- Charging must be performed in a well ventilated area.
- Inspect the charger DC plug for loose, bent, arced or dirty contacts.
- Inspect the vehicle receptacle for loose wires or damage.
- Insert plug fully into receptacle and check that the connection is tight.
- Be careful not to pull on the D. C. cord or place it in a position where it can be driven over or present a hazard to personnel working the area.

### **!!! WARNING !!!**

**WHEN CONNECTING OR DISCONNECTING THE CHARGER TO A VEHICLE, ALWAYS MAKE SURE THAT THE TIMER, ELAPSED TIME INDICATOR, OR POWER SWITCH IS SET IN THE OFF POSITION. IF IT IS NOT, AN ELECTRICAL ARC WILL OCCUR AND MAY CAUSE AN EXPLOSION OR FIRE.**

Observe the ambient temperature in the charging area. A battery requires a longer charge time than normal when the ambient temperature falls below 60° F. The time required increases as the ambient temperature decreases.

### **AC LINE VOLTAGE**

The battery charger's initial output is directly proportional to the input voltage. If a problem is encountered with several vehicles that indicates an insufficient initial (start) charge, it is suggested that the batteries be tested, and if found satisfactory, then the input AC voltage should be checked by the power company and their recommendations be followed. For additional information pertaining to the battery charger, see the 'Battery Charger Section' in this Manual.

### **ADDING WATER (FIGURE 8, PAGE 20)**

The electrolyte in the vehicle's batteries is a solution of sulfuric acid and water. Some of the water portion of this solution evaporates or is lost in the charging cycle but the acid is retained. In the life of a battery, it is only necessary to replenish water and not the acid.

In the life of an average battery, the water usage will be approximately 2-1/2 times the original electrolyte quantity, or approximately 16 quarts.

### **!!! WARNING !!!**

**IF A CONSIDERABLE AMOUNT OF BATTERY ELECTROLYTE IS SPILLED, IT MAY BE REPLACED. BE SURE TO OBSERVE ALL PROCEDURES, CAUTIONS, AND WARNINGS PROVIDED BY THE ELECTROLYTE MANUFACTURER.**



**!!! CAUTION !!!**

**OVERFILLING OF THE BATTERIES WILL VOID THE WARRANTY. SMITHCO SUGGESTS THE USE OF AN AUTOMATIC WATERING DEVICE THAT IS AVAILABLE FROM YOUR BATTERY DISTRIBUTOR.**

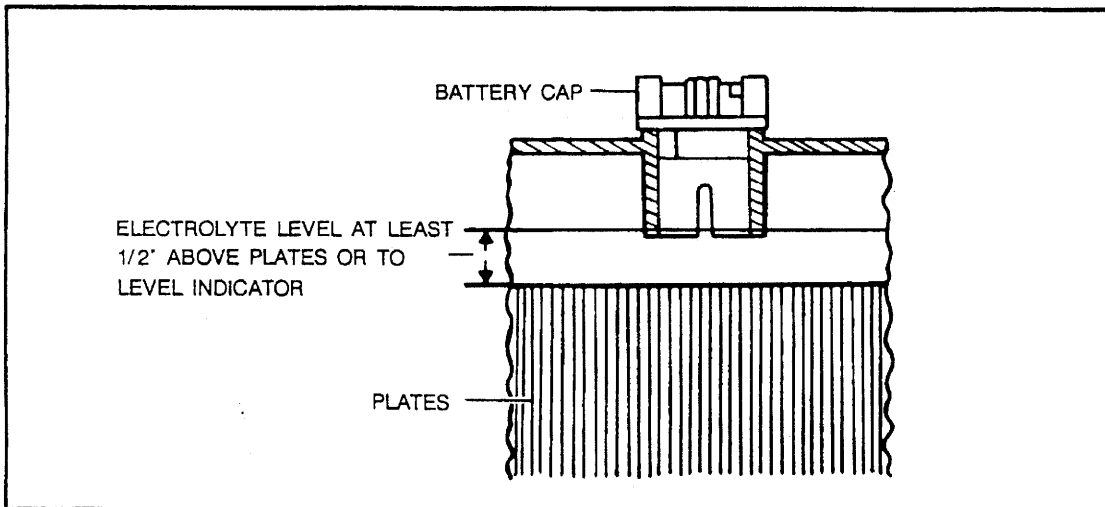

**FIGURE 8 BATTERY ELECTROLYTE LEVEL**

Add water to the indicator ring if equipped or to 1/2" above the top of the separators. Filling above this level will cause the loss of electrolyte during the charging cycle. The charging cycle causes bubbles to occur which will cause the electrolyte to fill the cavity above the plates. If the electrolyte is overfilled the gassing will force a portion of the electrolyte out through the vent holes in the vent caps. The result of this electrolyte loss will additionally result in corrosion of the wire and connections.

**!!! CAUTION !!!**

**BEFORE CHARGING, BE SURE THAT ELECTROLYTE IS ABOVE THE SEPARATORS. NEVER ALLOW THE ELECTROLYTE TO FALL BELOW THE TOP OF THE PLATES SINCE PERMANENT DAMAGE CAN RESULT TO THE UNCOVERED PORTION OF THE PLATES.**

## NOTE

It is recommended that any additional water required be added at the end of the charging cycle.

We recommend that all vent caps be removed and immersed in a clean container of water while watering the batteries. This will prevent loss of the caps and dilute any acid residue that could result in burned fingers. After replacing vent caps, rinse off batteries with a hose to eliminate any spilled electrolyte that may have been splashed during the watering operation.

## CLEANING

A coating of acid impregnated dirt on the top surface of a battery will create an electrical path between the terminals of the battery. This electrical path will cause a "current leakage" which will both reduce the operating efficiency of the battery and reduce its useful life.

### !!! CAUTION !!!

**BE SURE ALL VENT CAPS ARE SECURELY IN PLACE BEFORE CLEANING BATTERIES. THIS WILL PREVENT CONTAMINANTS FROM ENTERING BATTERIES.**

### !!! WARNING !!!

**USE EYE PROTECTION AND GLOVES DURING THE FOLLOWING CLEANING OPERATION.**

Wash with a hose and remove any remaining foreign matter using a stiff bristle brush and a solution of water and bicarbonate of soda (1 cup of bicarbonate of soda to 1 bucket, approximately 8 quarts of water). Hose off batteries after cleaning.

## TESTING BATTERIES

**WHAT TO CHECK:** If a vehicle fails to perform satisfactorily and it is suspected there is a battery failure, each battery should first be checked individually and then all batteries in the vehicle should be checked as a set.

**TEST WITH HYDROMETER:** Using a battery hydrometer, test each battery individually, comparing the three cell readings of each battery. If the variation between the highest and lowest cell readings in any one battery is .050 (50 gravity points) or more, there is reason to suspect a weak or failing cell. This test is best accomplished with the batteries in a PARTIALLY discharged state.

## INSTRUCTIONS FOR USING HYDROMETER (See Figure 9, page 22)

1. Draw the minimum of electrolyte into the test tube to permit the float to move freely without contacting the top or bottom of the test tube.
2. Hold hydrometer in a vertical position and take a reading at your eye level.

3. Always correct hydrometer Specific Gravity reading to 80° F. For each ten degrees temperature above 80° F, add 4 points to reading. Example: 90° F 1.250 Sp. Gr. = 1.254. For each ten degrees below 80° F, subtract 4 points from reading. Example 70° F 1.250 Sp. Gr. = 1.246.
4. Test each cell, record readings (corrected to 80° F). A variation of 50 points between any two cell readings (example 1.250 - 1.200) indicates a defect in the low reading cells.

### VOLTMETER CHECK

If the voltage of EACH cell cannot be measured, test the terminal voltage of each battery (if a set of batteries is being checked). Compare the voltage of the batteries against one another. If the battery voltage readings vary by 0.5 volts or more, there is probably a weak or failing battery. As stated under "Hydrometer Check" the voltmeter check is more effective if the batteries are partially charged.

If the batteries in the vehicle have been on charge and are to be tested with a voltmeter, drive the vehicle around for approximately 30 seconds, then let it stand idle for three or more minutes before testing. This stabilizes the voltage. In this instance, it removes a "surface charge" from the plates which would give a false high voltage reading.

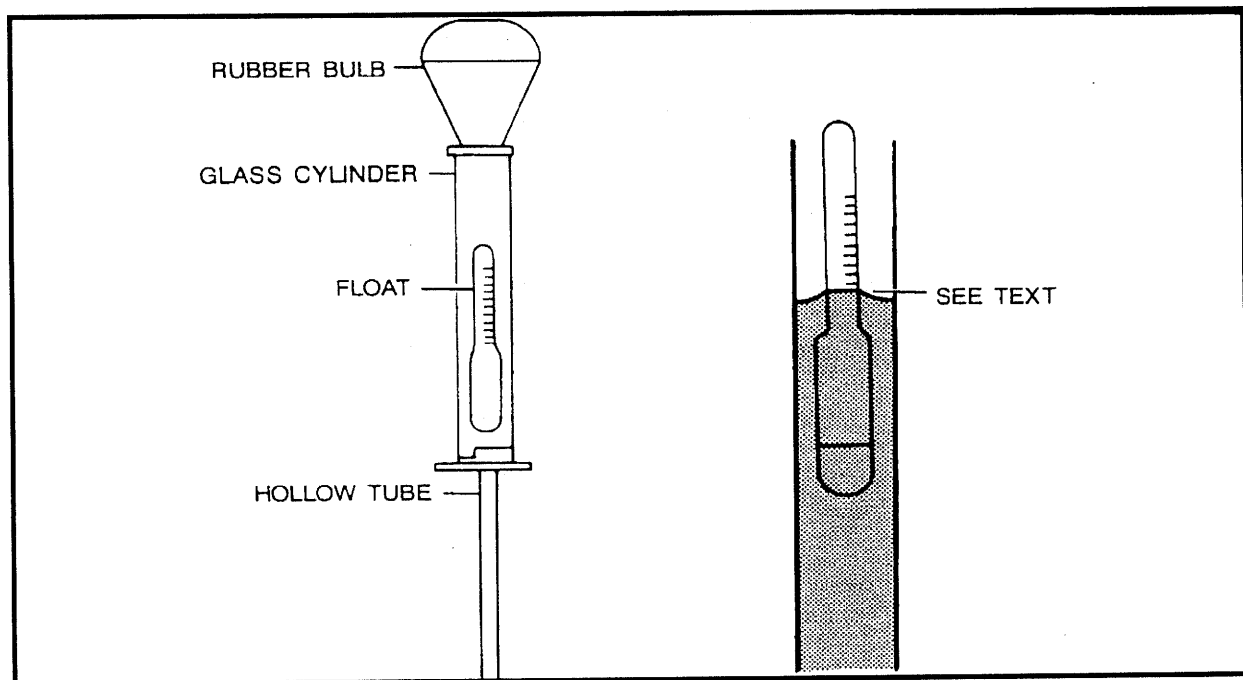

FIGURE 9 USING HYDROMETER

## **LOAD TEST**

This test is designed to simulate the demands imposed on batteries supplying power to electric vehicles.

Batteries fully charged and with the electrolyte temperature at  $80^{\circ}\text{F} \pm 5^{\circ}\text{F}$  ( $26.7^{\circ}\text{C} \pm 3^{\circ}\text{C}$ ) are discharged at the constant rate specified for the type battery being tested to a terminal voltage equivalent of 1.75 volts per cells. The discharge time in minutes is the battery capacity. The full charge electrolyte specific gravity is to be the same as specified gravity is to be the same as specified by the battery manufacturer.

Batteries should be tested as indicated above at a rate of  $75 \pm 1$  ampere. There are load testers on the market that are capable of testing batteries in the vehicle.

If the hydrometer or voltmeter check indicates a battery, or one battery in a set of batteries, is failing, fully charge it and conduct the above load test. Record the discharge time in minutes for the battery voltage to reach 5.25 volts. A battery which delivers 50% or less of its rated capacity in minutes should be replaced.

## **BATTERY LIFE**

The life of an electric vehicle battery is determined not only by the number of cycles (a discharge and a recharge) it receives but also by the 'depth' of each cycle. Continued "deep" discharging will reduce the life span at least one third.

# **BATTERY CHARGER**

## **DESCRIPTION**

Type of charger: Lestronic II (Smithco model number 832-016)

The battery charger is semi-automatic and is designed specifically for charging electric vehicle batteries.

The charger type is known as a ferroresonant. The term ferroresonant is applied to a charge that starts the charge at a relatively high rate of charge and continuously reduces the rate as the battery or batteries become nearer the full charge condition. When batteries are fully charged the charger will automatically shut off.

If charger does not start charging after being plugged in: Note these check points.

1. Connection may be loose. Check all connections making sure they are clean and secure.
2. Charge on batteries too low. If charge on batteries are below 2 volts, they will need to be charged individually to bring total charge of all batteries to total at least 15 volts. This should allow the charger to pickup and charge. Note: If (3) batteries have 5 volts charge and (1) battery has 1 volt charge. The charger may not charge.

## **CHARGER INSTALLATION**

Each charger requires an input of a dedicated 110-120 Volt AC 60 cycle 15 Amp circuit.

### **!!! WARNING !!!**

**PORTABLE CHARGERS SHOULD BE MOUNTED ON A PLATFORM ABOVE THE GROUND, OR IN SUCH A MANNER AS TO PERMIT THE MAXIMUM AIR FLOW UNDERNEATH AND AROUND THE CHARGER. IF THE CHARGER IS MOUNTED IN SUCH A MANNER THAT SUFFICIENT AIR FLOW IS PREVENTED FROM ENTERING THE LOUVERS, OVERHEATING MAY RESULT WHICH COULD CAUSE SERIOUS DAMAGE TO THE CHARGER AND THE POTENTIAL FOR FIRE.**

If the charger is operated in an outdoor location, rain and sun protection must be provided.

The charging (DC) cord is equipped with a polarized connector which fits into a matching receptacle on the vehicle.

The power (AC) cord is equipped with a standard three prong UL listed grounded type plug. Electrical outlet receptacles installed for use at the battery charging locations must be of the three prong grounded type (NEMA 15-5R), which will ground the charger to eliminate any electrical hazard,

## **SECTION 6: ELECTRIC MOTOR**

### **MOTOR REMOVAL AND DISASSEMBLY**

Disconnect battery wires

Remove all wires from motor. Mark the motor/axle housing at one of the bolts to ensure correct alignment when reinstalling the motor. Remove the 3 bolts and washers that secure the motor to the axle housing. Slide the motor out from the axle housing.

Loosen the nuts that attach terminals S1 and S2. Remove the two clamp bolts that secure the commutator end shield to the motor frame.

Slide the commutator end shield and the armature out of the motor frame. Remove the brushes. Reassemble in reverse order of disassembly and tighten end shield hardware to 100-120 in. lbs. torque.

**!!! CAUTION !!!**

**CARE MUST BE TAKEN IN HANDLING THE MOTOR TO PREVENT DAMAGE TO AXLE AND MOTOR SPLINES.**

### **ELECTRIC MOTOR REPAIR**

MAJOR motor repair should NOT be attempted by non-specialized staff. There are some maintenance and repair procedures that do not require specialized tools and knowledge that may be attempted. Replacement of brushes and field coils may be attempted; however, major repairs, such as armature turning or bearing replacement, should only be attempted by a qualified motor technician.

### **VOLTAGE AND RESISTANCE MEASUREMENT**

The following tests may be performed with an ohm meter or test light.

**!!! WARNING !!!**

**REMOVE BATTERY (+) CONNECTIONS BEFORE CONTINUING WITH THIS TEST. SHORTING OF MOTOR WIRES COULD RESULT IN AN EXPLOSION.**

Remove wires from motor terminals A1 and A2. Set the ohm meter to the RX1 scale. Using the ohm meter, place probes on motor terminals S1 and S2. A meter reading of "0" indicates a satisfactory condition at the field coils. No needle deflection indicates an "open" condition that will require the motor to be repaired or replaced.

Place the probes on motor terminals A1 and A2. A meter reading of "0" indicates a satisfactory condition at the brushes and rigging. No needle deflection indicates a condition that will require the motor to be repaired or replaced.

Check for continuity between each of the motor terminals and the motor shell. Continuity between terminals S1 and S2 to the motor shell indicates a short circuit between the field coils and the case. Continuity between terminals A1 and A2 to the motor shell indicates a short circuit in the armature. Both of the preceding conditions will require the motor to be repaired or replaced.

Tighten all motor terminal connections to 35-40 in. lb. Torque.

**ROUTINE EXAMINATION AND BRUSH REPLACEMENT (Figure 12)**

- 1. The motor is totally enclosed and brush wear is determined by use of a gauge inserted in a hole in the end shield as shown.

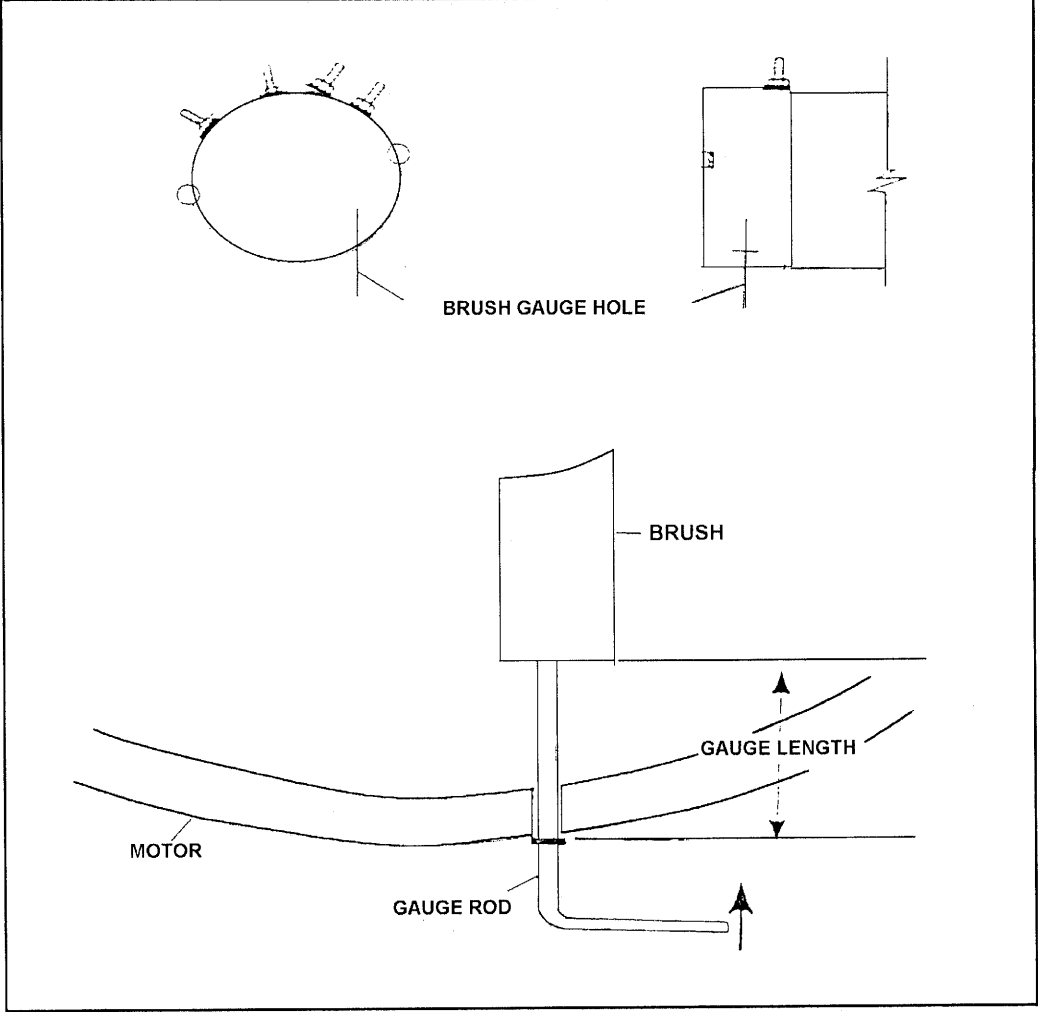

**FIGURE 12 BRUSH WEAR MEASUREMENT**

## NOTE

With new brushes, the gauge rod can be inserted approximately .78" into the brush measurement holes. Brushes should be replaced when rod can be inserted 1.56" into hole.

This leaves approximately 1/8" allowable wear remaining.

- a) If a brush is worn to a condition requiring replacement, the motor must be disassembled. [See Disassembly (After Removal From Rear Axle Assembly, page 29)].
- b) Check each brush for free movement in its holder and examine it for wear and general condition. If brush is broken, cracked, severely chipped, or worn to a length of less than 5/8 inch measured on the short side of the brush, replace it (Figure 13). Whenever any brushes are replaced, it is good practice to replace all of them. Keep extra brushes on hand.
- c) Examine the condition of the brush springs. Make sure the spring coils are uniform and the springs do not appear discolored which could indicate loss of spring quality. If these or other signs of spring damage are evident, replace the spring or use a small spring scale (Figure 14) to see if the spring requires one pound or more force to lift it at the point of contact with the worn brush.
- d) Observe the condition of the commutator and the armature coils which may be visible. Refer to Armature/Commutator Test procedures for details to look for during this inspection.

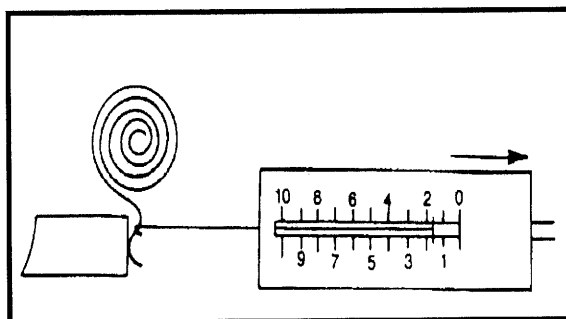
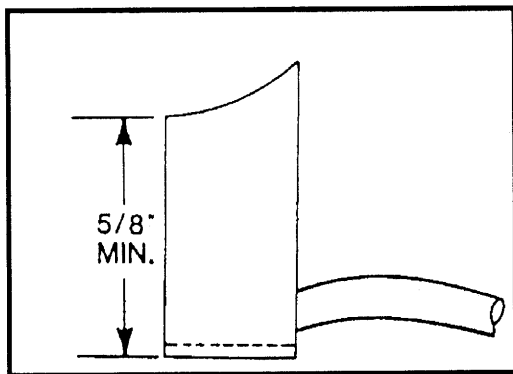

FIGURE 13 MINIMUM BRUSH LENGTH      FIGURE 14 BRUSH SPRING TENSION



## ELECTRIC MOTOR DISASSEMBLY (AFTER MOTOR REMOVAL FROM REAR AXLE)

1. Smooth away any signs of roughness or burrs from the shaft.
2. Mark the exact relationship between the motor housing and end shield with a chisel or marker.
3. Remove the clamp screws at the commutator end of the motor which hold the close fit rabbeted end shield to the motor housing.
4. If upon inspection, the armature or field coils appear oily, a faulty oil seal or "O" ring in the rear axle is suspected, allowing the rear axle lubricant to pass into the motor. Oil on a commutator will cause sparking, resulting in both rapid commutator and brush wear.
5. Disassemble the motor (See Motor Removal and Disassembly, Page 27). Clean armature and/or field coils by wiping with a clean cloth and contact cleaner or alcohol.
6. Remove the three screws (7) that retain the bearing retainer (8). Remove the bearing retainer and inspect the bearing (9) for wear or damage.
7. Lightly lubricate the bearing with motor oil and press into place. Reinstall bearing retainer. Reinstall retaining screws and "snug" into place.
8. Remove the motor housing assembly. When necessary, the field coils can be removed by removing the terminal screws, nuts, and the pole piece screws from the motor housing.
  - A. Remove the armature.
  - B. When necessary, the commutator end shield may be further disassembled to change brushes, brush rigging, and cross-over leads by removing the appropriate and obvious screws. This should be done if the brush holders or insulation plate appear burned, warped or have loosened rivets.

## INSPECTION OF ARMATURE

### NOTE

Replacement is suggested as the best means for maintaining the integrity of these heavy duty motors.

1. If deep burned sections are evident on the commutator bars, this is a symptom of an open circuit in the armature winding. If such evidence is noted, measure the armature resistance by selecting at random any two bars of the commutator with a bar span given in the Motor Reference Data. If this measurement does not meet the value given, the armature should not be used.

### NOTE

This condition could be caused by an undetected fault of manufacture appearing early in normal field service conditions, or it could be caused by overloading of the motor causing high temperature failure of connections. The resulting high resistance in a joint could cause this symptom appearance. Evidence of general overheating accompanying flat spots would tend to indicate overworking of the motor.

2. If one or more armature conductors are abnormally black or appear burned compared with the other armature conductors, this is an indication of shorted armature winding. If such evidence is detected, a dirty armature should first be blown off to clean it and then checked with a growler. If the short circuit is not confirmed by these indications, check resistances and apply a high potential test not exceeding 600 volts AC for 1 minute. If the armature does not pass these tests, it should not be used.

### MOTOR REFERENCE DATA

Horsepower - 60 min.	2
Speed in RPM (nominal)	2800
Volts DC	36
Amperes at Full Load (nominal)	55
Winding	Series
Enclosure	Totally Enclosed
Winding Resistance at 25 degrees C (77 degrees F) Armature (Between 1-17 Bar Span	.00193 plus or minus .0019 ohm
Series Field (S <sub>1</sub> - S <sub>2</sub> )	.0086 plus or minus .0009 ohm

### HIGH POTENTIAL LAMP TEST ARMATURE AND FIELD.

Construct a test fixture as per Figure 15.

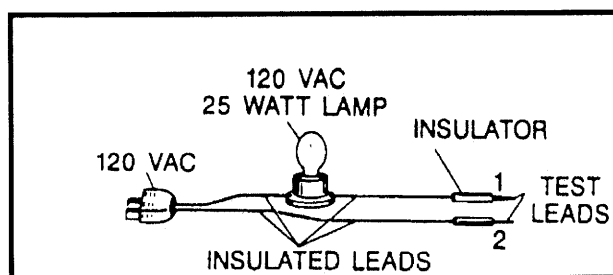

FIGURE 15 HIGH POTENTIAL LAMP TEST FIXTURE

### WARNING

TEST FIXTURE TO BE CONSTRUCTED AND OPERATED ONLY BY QUALIFIED ELECTRICAL SERVICE PERSONNEL. SEVERE ELECTRICAL SHOCK OR ELECTROCUTION MAY RESULT.

## **ARMATURE/COMMUTATOR TESTING**

1. Grounded Commutator Segment to Armature Test
  - a) Attach test lamp lead #1 to armature shaft.
  - b) Touch test lamp lead #2 to each segment of the commutator.
  - c) If test lamp illuminates, a short is present between armature shaft and the commutator segment
  - d) If test lamp does not illuminate, the test is satisfactory.
2. Open Commutator Segments Test
  - a) Touch test lamp leads #1 and #2 between opposite segments of the commutator.
  - b) If test lamp illuminates, the segment is satisfactory.
  - c) If test lamp does not illuminate, the segment is open.
3. Shorted Commutator Segments Test
  - a) Touch test lamp lead #1 to A segment.
  - b) Touch test lamp lead #2 to each segment in turn.
  - c) If test lamp lights at other than the opposite segment of commutator, the commutator winding is shorted.

## **FIELD COILS**

1. Grounded Field Coils Test
  - a) Attach test lamp lead #1 to motor housing.
  - b) Touch test lamp lead #2 to terminals S1 and S2 on housing.
  - c) Test lamp should not illuminate. If test lamp illuminates, the field coils are shorted to motor housing.
2. Open Field Coil Test
  - a) Attach test lamp lead #1 to terminal.
  - b) Attach test lamp lead #2 to terminal.
  - c) Test lamp should illuminate. If test lamp does not illuminate, the field coils are open.

**THE FOLLOWING TESTS ARE TO BE COMPLETED AFTER MOTOR REPAIR AND BEFORE INSTALLATION IN VEHICLE. (AFTER MOTOR REASSEMBLED SEE WIRING DIAGRAM)**

1. Armature To Field Coil Short Test

- a) Attach test lead #1 to terminal A1.
- b) Attach test lead #2 to terminal F1.
- c) Test lamp should not illuminate. If test lamp illuminates, motor should be disassembled to locate source of problem.

2. Armature To Motor Case Short Test

- a) Attach test lamp #1 to terminal A1.
- b) Attach test lead #2 to terminal A1 (lamp should light), then A2.
- c) Test lamp should not illuminate. If test lamp illuminates, the motor should be disassembled to locate source of problem.

3. Field Coil To Case Test

**NOTE**

Short circuited coils can be caused by several things, as well as an undetected manufacturing fault which most likely would show up early in normal service.

- a) If a generally heat discolored appearance uniformly over the commutator or windings is observed, it is usually a sign of overloading of the vehicle or motor. This should be corrected or the symptoms will be repetitive and motors will be burned out frequently.
- b) Bubbled insulation and individual brush burn marks on the commutator is a typical example of a motor armature which has been loaded to stall with power applied, overheating and its elements boiled to failure.

**COMMUTATOR INSPECTION AND CARE**

**NOTE**

The following operations should only be performed by an experienced and competent electric motor shop.

1. Inspect the commutator during each brush inspection.
2. Commutator bars should not be pitted, burned or grooved in the brush track. If found in this condition, the surface should be refinished in a lathe, limiting the depth of cut to .005 inch or less on a side and repeat until smooth.
3. Before a final cut, the mica insulation between commutator bars should be undercut, 0.32 inch and no mica slivers should be left along the side of the bars above the undercut.

4. Next, dynamic balance the armature to within .0015 inch amplitude at 3000 RPM. After this, the final finish cut should be made with a diamond tool to obtain a surface finish of 8 to 16 micro inch. The armature should not be put back in service with a diameter of less than 2.625 inches.
5. After refinishing a commutator, check it for eccentricity. It should not exceed .001 inch total indicator reading for the entire diameter and with a .002 inch maximum bat-to-bar difference.

### **INSPECTION OF FIELD WINDINGS**

If upon inspection, the insulation on the field coils appears blackened or charred, the serviceability of the coils is questionable. Burned or scorched coil insulation is a symptom of coil overheating due to overloads, grounded or short circuited windings.

To check the windings electrically for grounds or open circuits, a continuity tester, ground tester, and ohm meter are required.

To check for a grounded field connect the tester between terminal studs S1 to ground and S2 to ground.

To check for an open or shorted winding; connect the ohm meter between S2 and S1 on the motor.

### **BEARING INSPECTION AND CARE**

1. The bearing is prelubricated with Chevron SR1-2 high temperature grease or equivalent, sufficient for the life of the bearing.

**NOTE**

Do not use silicone grease in a DC motor.

2. Check the bearing by turning it with your fingers. Feel for bindings or gritty effects and for excessive looseness or wobble. If any defect is apparent or if there is any doubt at all as to serviceability of the bearing, replace it with a new one.
3. Remove the old bearing by using a suitable bearing puller. Press new bearing into place by means of an arbor press that exerts pressure on the inner ring.

**!!! CAUTION !!!**

**DO NOT USE A HAMMER FOR BEARING REPLACEMENT. IT WILL DAMAGE THE BEARING.**

## REASSEMBLY

1. Install the bearing and retainer in the end shield.
2. Set commutator end shield in place on bench with the brush rigging facing upward. Push each brush back up into brush holder until its end would permit commutator to pass under without hitting. Adjust end of spring so that it is against side of brush and holds brush in "cocked" position.
3. Set armature into place in the end shield.
4. Push on end of each brush to release onto the commutator. Observe that all brushes seat on commutator properly and that end of springs ride on brush tops in line with brush holder grooves. Make sure that the brush spring will travel down the holder slot as the brush wears.
5. Position the motor housing over the armature and position it exactly with mark on end shield. Gently seat on rabbet.
6. Gently fit the motor over the rear axle input spline. Line up marks and secure the motor to the rear axle with the existing hardware.
7. Be sure the end shield is a snug fit in the stator rabbet, then replace the clamp screws. Check to determine that armature is free to turn. If it will not turn, check the assembly.
8. Make a high potential test (up to a maximum of 600 volts AC for 1 minute) to assure motor has been properly reassembled.

## PARTS IDENTIFICATION

1. The motor model number identifies every part of the motor.
2. When ordering, always describe the particular part and refer to the motor model number.

### ADVANCED D.C. MOTOR WARRANTY

All motors are guaranteed against defects in materials and workmanship for a period of one year from date of purchase from SMITHCO. All motors returned are subject to manufacturers inspection. Excluded from warranty are motors damaged due to (1) Stalling the armature, (2) Operating the motor under low voltage conditions, (3) Exceeding the r.p.m. limit of the motor.

### !!! MOTOR WARNING !!!

1. **Do not** jack-up the rear of the unit and fully depress the accelerator. By doing so, the motor can reach speeds in excess of 10,000 r.p.m., in five seconds or less, exceeding the r.p.m. limit of the motor. When testing the motor, just slightly depress the accelerator to check the operation of the unit. Then let the unit down and drive under normal conditions to check the performance.
2. Do not drive the unit down hill faster than it will go on a level surface.

## FAULT FINDING

The MillipaK controller includes a number of features designed to help the user track down operational faults, wiring faults or internal controller faults.

The Diagnostic LED mounted next to the calibrator connectors on the front of the controller serves as a simple diagnostic tool as explained below:

ON	No fault, normal condition
OFF	Internal controller fault
1 flash	Personality out of range
2 flashes	Illegal start condition (Traction)
3 flashes	MOSFET Short Circuit
4 flashes	Contactora fault, Motor Open Circuit or Field Open Circuit
5 flashes	Not used
6 flashes	Accelerator wire off fault
7 flashes	Low or High battery voltage, High Capacitor voltage
8 flashes	Over temperature or 12T cutback

### FLASH FAULT DESCRIPTIONS

In addition to the LED indication a more detailed description of any faults detected may be found by using the calibrator. Menu item number 13.01 gives a code which corresponds to the following detected faults.

ID	FAULT	DESCRIPTION	FLASH FAULT
0	System OK		On
1	Thermal Cutback	Maximum power available to the motor has been reduced due to excessive heat sink temperature.	8
2	12t Current Limit Cutback	Maximum power available to the motor has been reduced by the 12t current limit cutback function.	8
3	Accelerator Wire Off	Input wire from accelerator has been disconnected.	6
4	Accelerator Pressed at Power Up	Accelerator pedal pressed at power up	6
5	Belly Fault	The belly switch function has occurred	2
6	Seat Fault	Drive selected and no seat switch closed	2
7	FSI Recycle Fault	FSI switch needs to be recycled after a direction change	2
8	SRO Fault	Direction switch selected for greater than 2 seconds with FSI open.	2
9	Two Direction Fault	Two directions selected together	2
10	Sequence Fault	Direction or FSI switch closed at power up.	2
11	Low Battery Fault	Battery voltage is too low.	7
12	High Battery Fault	Battery voltage is too high.	7

13	High Battery Fault with Line Contactor Open	Battery voltage is too high before the line contactor is closed.	7
14	Configuration Range Fault	A personality is out of range.	1
15	Configuration CRC Fault	The personality CRC is incorrect.	1
16	Line Contactor Welded Fault	Line contactor is welded.	4
17	Line Contactor did not close fault	Line contactor is open circuit.	4
18	No Fault		On
19	Field Open Circuit	Field Open Circuit detected.	4
20	MOSFET Short Circuit	Short circuit Armature MOSEFTs detected.	3
21	VA Detect Fail	12V supply failure	0
22	MOSFET Off	MOSFETs did not pulse during power on failsafe checks (failsafe circuit enabled.)	0
23	MOSFET On	MOSFETs pulsed during power on failsafe checks (failsafe circuit disabled).	0
24	MOSFET Short Circuit during Power Up	Short circuit armature MOSFETs detected during power on failsafe checks.	3
25	Drive 2 Off	Contactator 2 did not pulse during power on failsafe checks (failsafe circuit enabled.)	0
26	Drive 2 On	Contactator 2 pulsed during power on failsafe checks (failsafe circuit disabled.)	0
27	Drive 1 Off	Contactator 1 did not pulse during power on failsafe checks (failsafe circuit enabled.)	0
28	Drive 1 On	Contactator 1 pulsed during power on failsafe circuit disabled.)	0



# The Smithco Commercial Products Two-Year Limited Warranty

Smithco, Inc. (Smithco) warrants your 2007 or newer Smithco Commercial Product ("Product") purchased after January 1, 2007, to be free from defects in materials or workmanship for the period of time listed below. Where a warrantable condition exists, Smithco will repair the Product at no cost to you including diagnosis, labor (at the Smithco standard labor rate, subject to the Smithco flat rate schedule), and parts.

## Warranty Duration Is:

1. Two years, 1500 operational hours\* from the date of delivery to the original purchaser or three years from the date of original manufacturer of the product, whichever occurs first. (\*Products equipped with hour meter).
2. Products used in rental situations are covered for 90 days from date of delivery to original user/renter.

## Owner responsibilities:

As the Product owner, you are responsible for required maintenance and adjustments stated in your Owner's Manual. Failure to perform required maintenance and adjustments can be grounds for disallowing a warranty claim. **You are particularly responsible to train all present and future operators of this product on the safe operation of this product at your location.**

## Instructions for Obtaining Warranty Service:

You are responsible for notifying the Authorized Smithco Products Distributor from whom you purchased the Product as soon as you believe a warrantable condition exists and not later than 30 days from discovery of the condition.

If you need help locating an Authorized Smithco Distributor, or if you have questions regarding your warranty rights or responsibilities, you may contact us at:

Smithco Product Support Department  
Highway 55 @ Poplar St.  
Cameron, Wisconsin 54822  
Telephone: 715-458-4192      E-Mail: [ProductSupport@Smithco.com](mailto:ProductSupport@Smithco.com)

## Maintenance Parts:

Parts scheduled for replacement as required maintenance ("Maintenance Parts"), are warranted for the period of time up to the scheduled replacement time for that part.

## Items/Conditions Not Covered:

Not all product failures or malfunctions that occur during the warranty period are defects in materials or workmanship. The items/conditions listed below are not covered by this warranty.



Product failures which result from the use of non-Smithco replacement parts, or from installation and use of add-on, modified, or unapproved accessories are not covered.



Product failures which result from failure to perform required maintenance and/or adjustments are not covered.



Product failures that result from operating the Product in an abusive, negligent or reckless

manner are not covered.



This warranty does not apply to parts subject to consumption through use, unless found to be defective. Examples of parts which are consumed, or used up during normal Product operation include, but are not limited to: blades, tines, teeth, scarifiers, rakes, plates, wear plates, castor wheels, tires, batteries, filters, belts, nozzles, etc.



This warranty does not apply to failures caused by outside influence. Items considered to be outside influence include, but are not limited to, weather, storage practices, contamination, use of unapproved coolants, lubricants, additives, or chemicals, etc.



This warranty does not apply to normal "wear and tear" items. Normal "Wear and Tear" includes, but is not limited to, damage to seats due to wear or abrasion, worn painted surfaces, scratched decals or windows, etc.



Smithco may require the return of failed parts or components in order determine the validity of any warranty claim.



Smithco will not be obligated to replace components of other manufacturers if inspection by the original component manufacturer indicates that failure was due to normal wear and tear, expected consumption through use or improper care or service.

#### **Other Legal Disclaimers:**

The above remedy for product defects through repair or replacement by an authorized Smithco distributor or dealer is the purchaser's sole remedy for any defect. This warranty gives you specific legal rights, and you may also have other rights which vary from state to state.

**THERE ARE NO OTHER EXPRESS WARRANTIES OTHER THAN THOSE SET FORTH ABOVE. ALL IMPLIED WARRANTIES OF MERCHANTABILITY AND FITNESS FOR USE ARE LIMITED TO THE DURATION OF THE LIMITED WARRANTIES CONTAINED HEREIN.**

Some States may not allow limitations on how long an implied warranty lasts, so the above limitation may not apply to you.

**THE SMITHCO COMPANY IS NOT LIABLE FOR INDIRECT, INCIDENTAL OR CONSEQUENTIAL DAMAGES IN CONNECTION WITH THE USE OF THE PRODUCT, INCLUDING ANY COST OR EXPENSE OF PROVIDING A SUBSTITUTE PRODUCT OR SERVICE DURING PERIODS OF MALFUNCTION OR NON-USE.**

Some states may not allow the exclusion of indirect, incidental or consequential damages, so the above exclusion may not apply to you.

**Smithco neither assumes, nor authorizes any person to assume for it, any other liability in connection with the sale or use of this product.**

**SMITHCO, INC.  
WANYE, PA 19087**

