

Parts Manual



SUPER STAR "E" 48V
8440 & 8450
SN: EM835

Revised April, 2012

Product Support: 1020 Hwy 224; Humboldt, KS 66748
1-888-422-5173 lj@smithco.com

TABLE OF CONTENTS

<i>TITLE</i>	<i>PAGE</i>
Main Frame Drawing & Parts List	3-4
Body Assembly Drawing & Parts List	5-6
Brake Linkage Drawing & Parts List	7-8
Accelerator Pedal Assembly Drawing & Parts List	9-10
Steering Group Assembly Drawing & Parts List	11-12
Rear Axle Assembly Drawing & Parts List	13-14
Brake Shoe Drawing & Parts List	15
Motor Assembly Drawing & Parts List	16
Wiring Diagram & Parts List	17-18
Battery Installation Instructions	19-22

ACCESSORIES

42-401 Manual Lift Drawing & Parts List	23-25
42-011 Sand Plow Drawing & Parts List	26-27
42-136 Sand Plow Drawing & Parts List	28-29
42-223 Adjustable Disc Edger Drawing & Parts List	30-31
42-750 Cart Path & Sidewalk Edger Drawing & Parts List	32-33
42-008 Sand Cultivator Drawing & Parts List	34-35
42-010 Leveling Blade Drawing & Parts List	36-37
42-210 Grader Blade Drawing & Parts List	38-39
42-178 Infield Scarifier w/Vertical Blades Drawing & Parts List	40-41
42-178 Mounting Drawing & Parts List	42-43
42-179 Infield Scarifier w/Chisel Blades Drawing & Parts List	44-45
42-179 Scarifier Mounting Drawing & Parts List	46-47
42-285 Scarifier w/Vertical Blades Drawing & Parts List	48-49
42-285 Scarifer Mounting Drawing & Parts List	50-51
42-026 Stainless Steel Tournament Rake Drawing & Parts List	52-54
42-128 Stainless Steel Tournament Rake Drawing & Parts List	55-57
13-438 Rake Assembly w/Finish Blades Drawing & Parts List	58-59
13-606 Rake Assembly w/Lexan Blades Drawing & Parts List	60-61
13-684 Sand Rake Brush Kit Drawing & Parts List	62-63
13-298 Fan Rake Attachment Drawing	64
13-319 Fan Rake Kit Drawing	64
13-298 Fan Rake Attachment Parts List	65
13-319 Fan Rake Kit Parts List	65
26-007 Infield Finisher Drawing	66
42-185 Drag Mat Kit Drawing	66
26-007 & 42-185 Parts List	67
43-002 Flex Action Field Finisher w/Brush Drawing & Parts List	68-71
26-008 Flex Action Field Finisher Drawing & Parts List	72-74
43-043 Finishing Brush Kit Drawing & Parts List	75-76
42-582 Green Star RBS Drawing & Parts List	77-78
42-586 Green Star RBS Main Frame Drawing & Parts List	79-80
42-800 ROPS Drawing, Parts List & Installation Instructions	81-82

8440 MAIN FRAME DRAWING

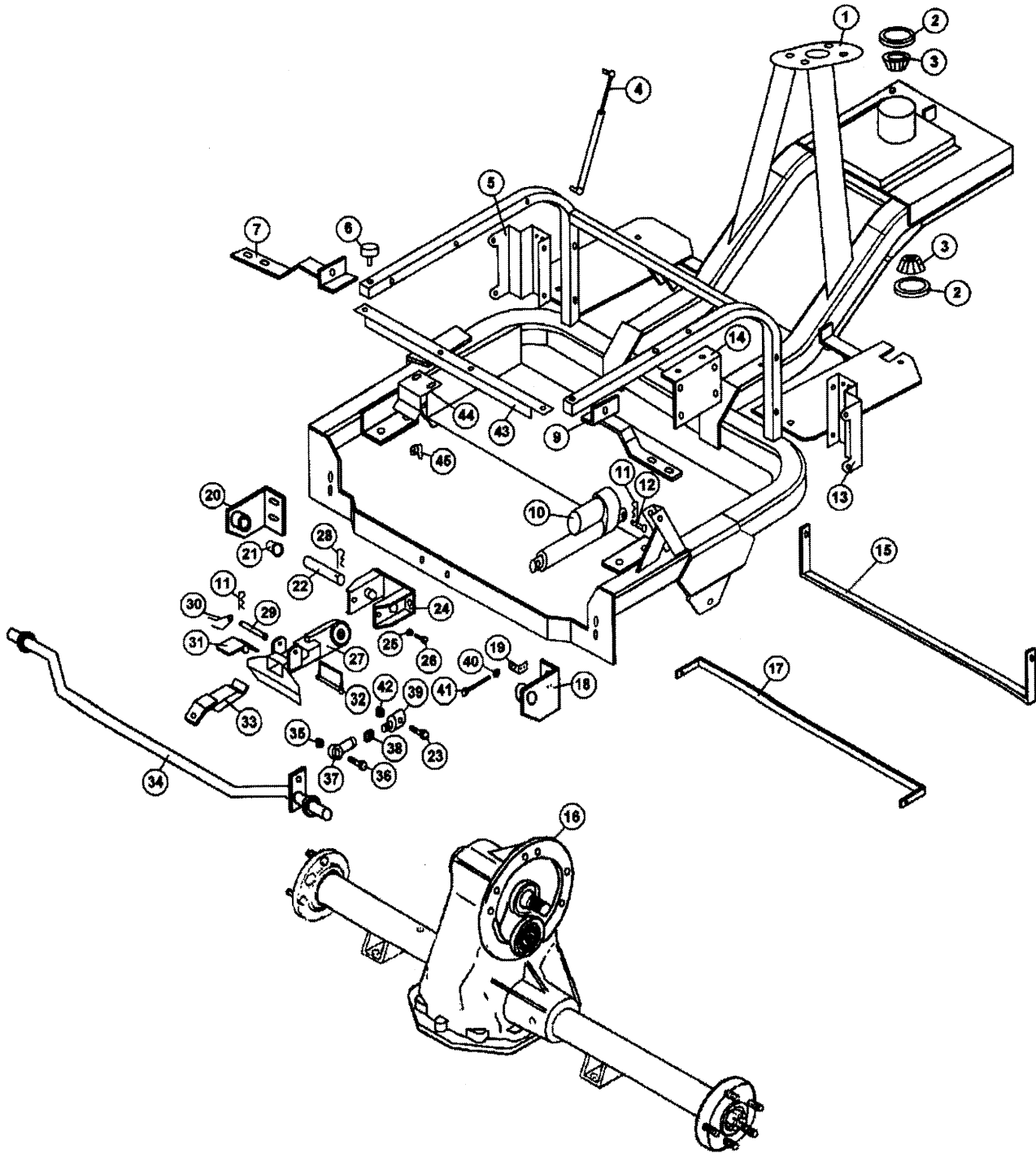

8440 MAIN FRAME PARTS LIST

REF#	PART#	DESCRIPTION	QTY.
1	843-107	Main Frame	1
2	932-022	Seal	2
3	932-023	Bearing	2
4	41-128	Shock	1
5	943-114	Front Tank Mount Left	1
6	730-038	Rubber Mount	2
7	943-123	Rear Tank Mount Left	1
8	943-140	Rake Lift Assy.	1
9	843-112	Rear Tank Mount Right	1
10	832-002-1	Actuator 24 Volt 1000#/4" Stroke	2
11	400-307	Hair Pin	3
12	40-396	½" Pin	2
13	943-112	Front Tank Mount Right	1
14	843-109	Controller Plate	1
15	843-111	Battery Hold Down	1
16	843-108	Axle	1
17	843-194	Battery Stop	1
18	943-191	Pivot Bracket Right	1
19	943-192	Switch Bracket	1
20	943-193	Pivot Bracket Left	1
21	720-064	Bronze Bushing	2
22	943-181	Clevis Pin 7/8" x 3 ½"	1
23	400-028	½" – 13 x 2" HHCS	1
24	943-194	Frame Mount	1
25	400-105	½" Nut	2
26	400-027	½" x 1 ½" HHCS	2
27	943-183	Lift Arm	1
28	2050	Snap Pin	1
29	943-178	Clevis Pin ½" x 3 ½"	1
30	943-180	Torsion Spring	1
31	943-179	Lock	1
32	943-190	Wire Lock Pin	1
33	943-182	Towing Hitch	1
34	943-196	Lift Bar	1
35	400-106	5/8" Hex Nut	1
36	400-319	5/8" – 11 x 2 ½" Bolt	1
37	932-121	5/8" Ball Joint	1
38	932-122	5/8" Nut	1
39	943-175	Actuator Adjusting Rod	1
40	400-102	5/16" Nut	1
41	400-055	5/16" – 18 x 3" HHCS	1
42	400-112	½" Locknut	1
43	843-193	Cover Bracket Brace	1
44	843-192	Cover Bracket	1
45	843-172	Cover Latch	1

8440 BODY ASSEMBLY DRAWING

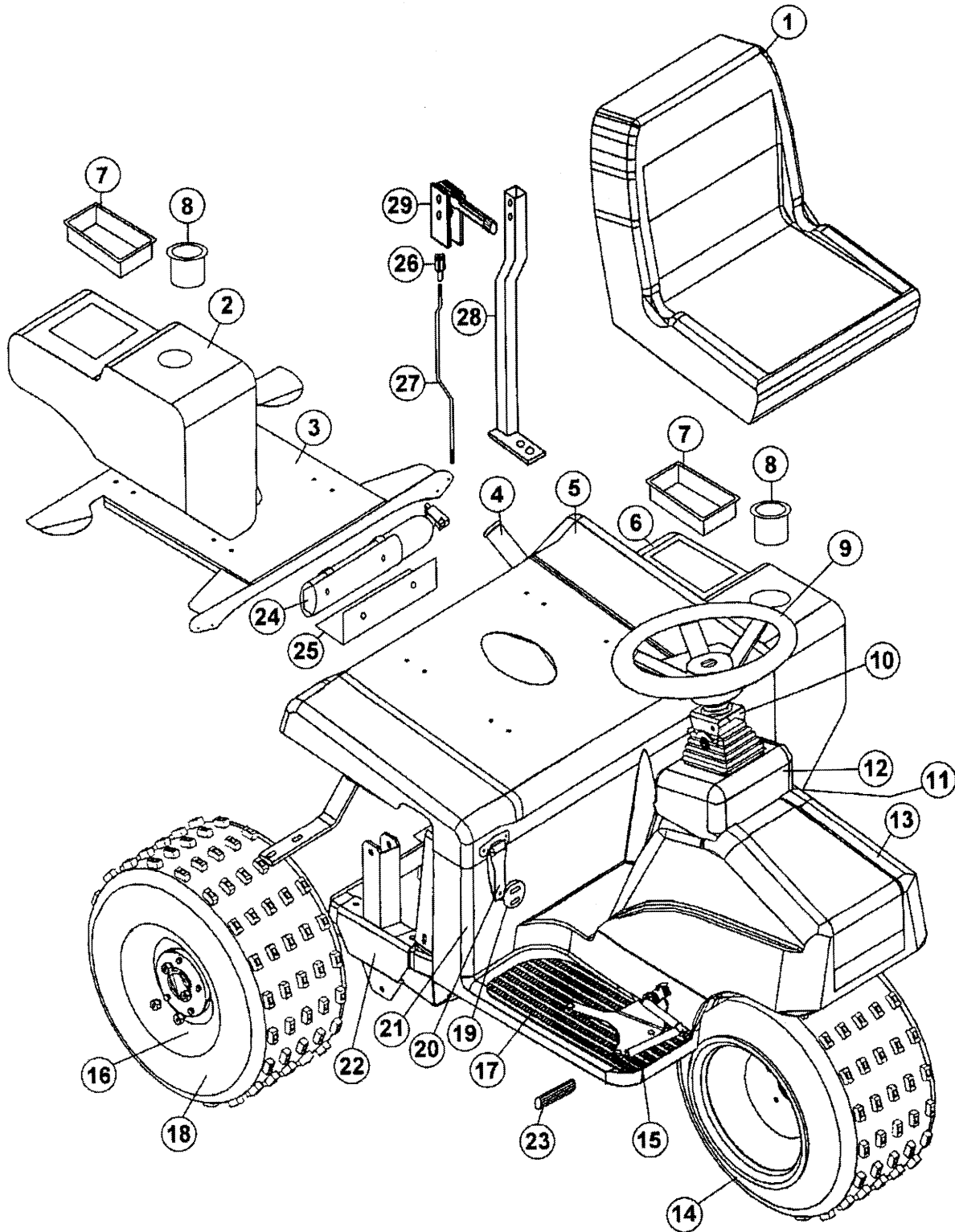

8440 BODY ASSEMBLY PARTS LIST

REF#	PART#	DESCRIPTION	QTY.
1	832-123	Low-Back "SMITHCO" Seat	1
2	943-110-1	Gas Tank	1
3	943-105	Seat Plate	1
4	943-132	Rake Holder	1
5	843-009	Rear Cover	1
6	943-111	Tool Box	1
7	943-117	Tray	1
8	943-116	Cup Holder	1
9	730-046	Steering Wheel	1
10	832-028	Tilt Steering & Boot	1
11	943-129	Left Floor Mat	1
12	943-108	Console	1
13	943-107	Nose Cone	1
14	932-090	Wheel & Tire	3
15	943-124	Accelerator Pedal	1
16	932-090-2	Wheel	3
17	943-128	Right Floor Mat	1
18	932-090-1	Tire	3
19	732-017	Charger Receptacle	1
20	730-058	Hinge	2
21	943-106	Floorboard	1
22	843-107	Frame	1
23	943-127	Accelerator Pedal Pad	1
24	843-113	Fire Extinguisher	1
25	843-114	Fire Extinguisher Bracket	1
26	11-101-1	Yoke	1
27	843-155	Brake Rod	1
28	843-156	Brake Bracket	1
29	44-763	Brake Lever	1

8440 BRAKE LINKAGE DRAWING

BRAKE LINKAGE

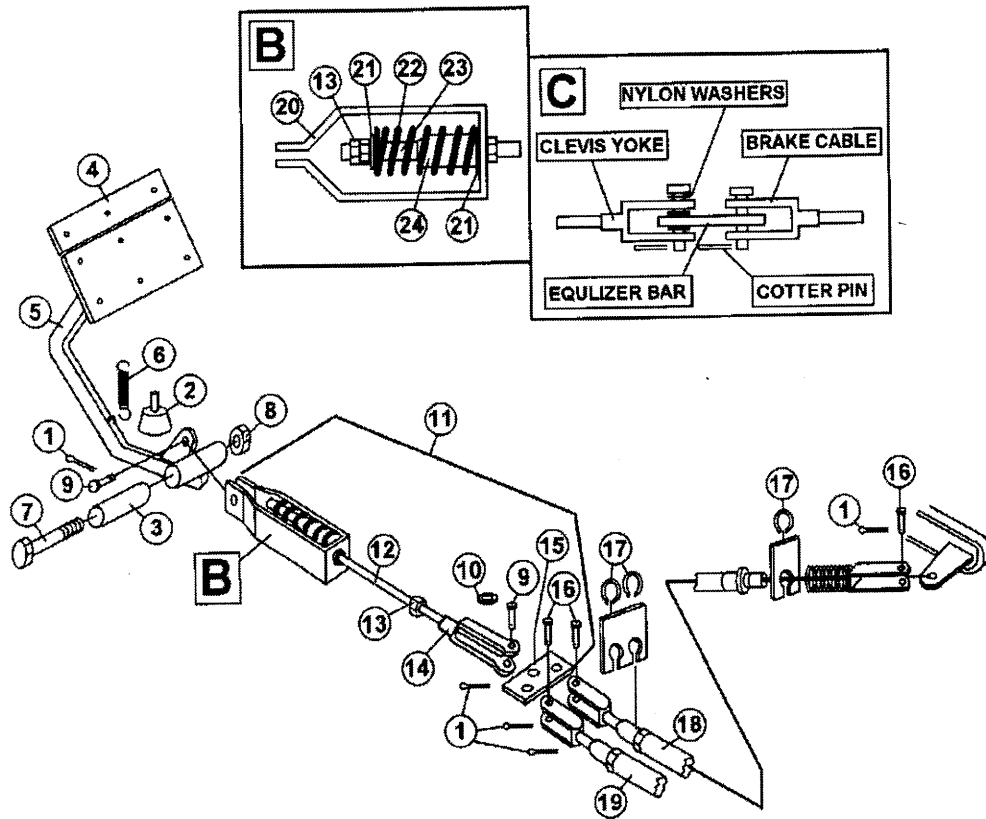

8440 BRAKE LINKAGE PARTS LIST

REF#	PART#	DESCRIPTION	QTY.
1	720-079	Cotter Pin 3/32" x 3/4"	5
2	732-008	Rubber Stud Bumper	1
3	720-009	Bronze Bushing 1/2" ID x 1 1/16" OD x 2	1
4	732-024	Brake Pad Set	1
5	943-154	Brake Assembly	1
6	40-199	Idler Spring	1
7	400-029	1/2" - 13 x 3 " Bolt	1
8	400-112	1/2" - 13 Locknut 2-Way	1
9	720-078	Clevis Pin 5/16" x 1"	2
10	732-053	Nylon Washer	3
11	732-020	Compensating Link Assembly	1
12	732-047	Adjusting Rod	1
13	400-118	5/16" Hex Nut x 24 Thread	3
14	11-101-1	Linkage Yoke 24 Thread	1
15	732-052	Equalizer Bar	1
16	720-087	Clevis Pin 5/16" x 3/4"	3
17	730-240	Brake Cable Retaining Clip 1/2"	4
18	843-120	Brake Cable Right (Long)	1
19	730-029	Brake Cable Left (Short)	1
20	732-048	Brake Yoke Housing	1
21	400-202	5/16" Flat Washer	2
22	732-050	Compression Spring	1
23	732-049	Brake Tube	1
24	732-051	Nylon Bushing	1

8440 ACCELERATOR PEDAL ASSEMBLY DRAWING

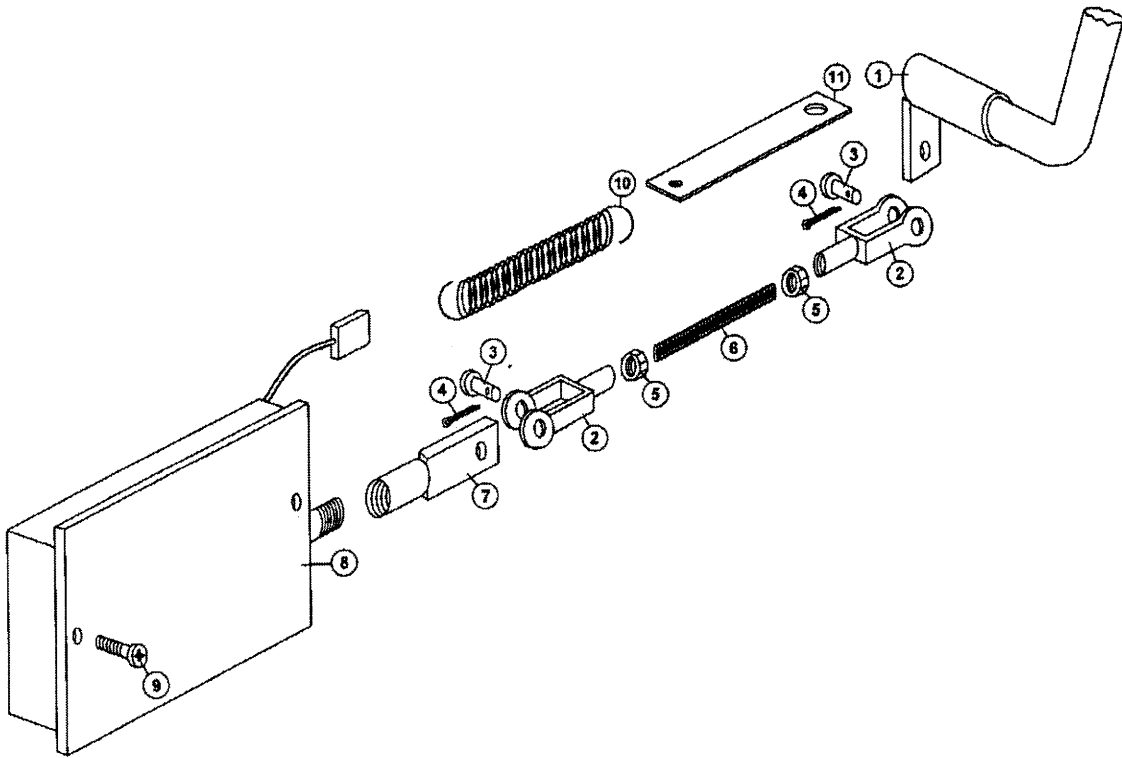

8440 ACCELERATOR PEDAL ASSEMBLY PARTS LIST

REF#	PART#	DESCRIPTION	QTY.
1	943-124	Foot Pedal Assembly	1
2	11-101-1	Linkage Yoke	2
3	720-078	Clevis Pin 5/16" x 1"	2
4	720-079	Cotter Pin 3/32" x 3/4"	2
5	400-118	5/16" - 24 Hex Nut	2
6	843-153	5/16" Accelerator Rod	1
7	750-649	Accelerator Clevis	1
8	750-607	Accelerator	1
9	400-320	5/16" x 1" - 18 Pan Head Bolt	2
10	1071	Spring	1
11	943-155	Spring Bracket	1

8440 STEERING GROUP ASSEMBLY DRAWING

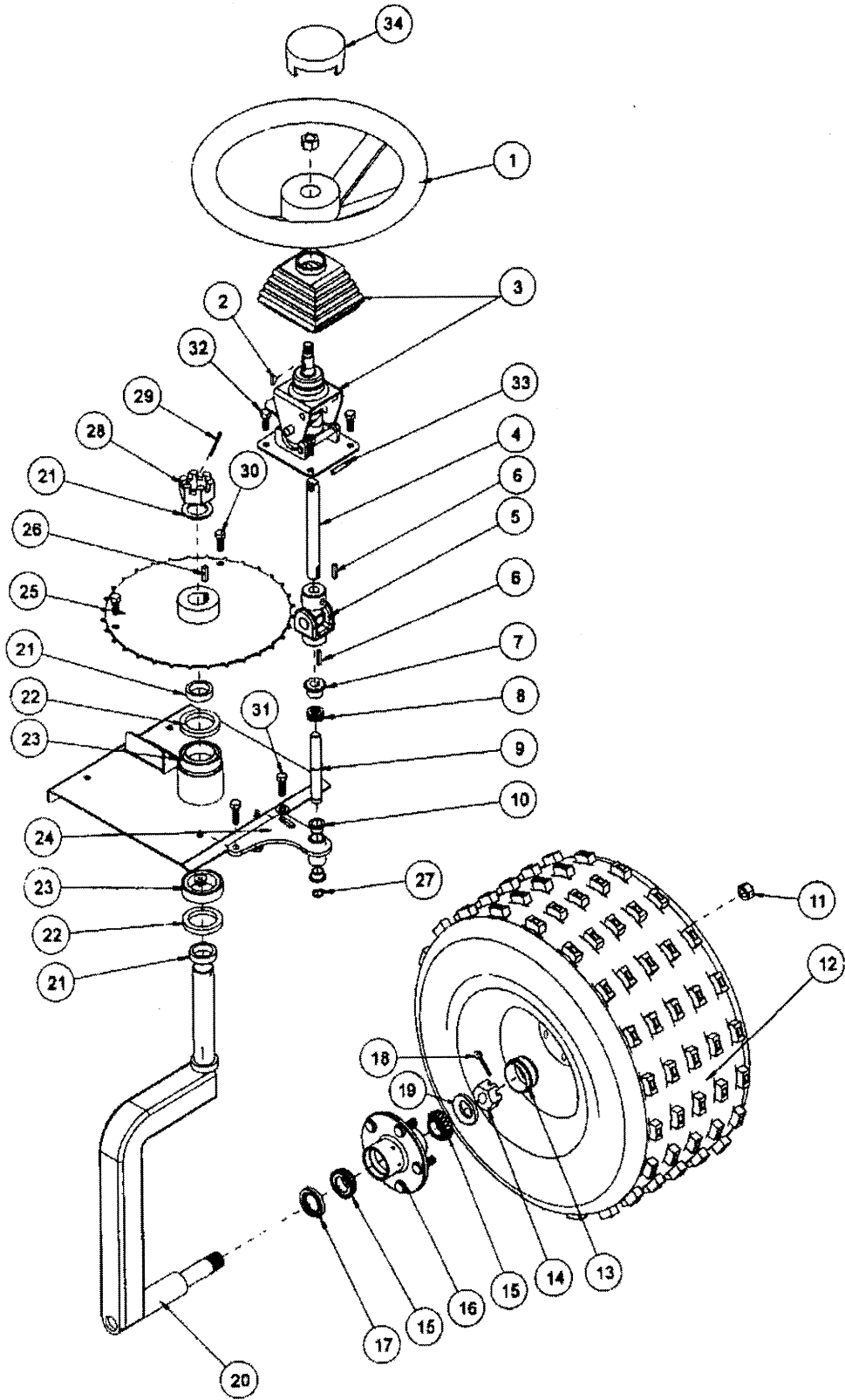

8440 STEERING GROUP ASSEMBLY PARTS LIST

REF.#	PART#	DESCRIPTION	QTY.
1	730-046	Steering Wheel	1
2	740-023	Woodruff Key 3/16" x 3/4"	1
3	832-028	Tilt Steering	1
4	943-021	Upper Steering Shaft	1
5	932-035	U-Joint	1
6	1088	3/16" x 1" Key	2
7	932-030	Steering Sprocket 10T	1
8	40-166	Machine Bushing 5/8 x 14GA	3
9	932-034	Bottom Steering Shaft	1
10	932-051	Oilite Bushing 5/8" ID x 3/4" OD	2
11	1187	Lug Nut	4
12	932-020	Wheel & Tire	1
13	2024	Grease Cap	1
14	709-126	Spindle Nut	1
15	2028	Tapered Bearing	2
16	2027-1	Hub Only	1
17	709-171	Seal	1
18	720-043	Cotter Pin 1/8" x 1 1/2"	1
19	2013	Spindle Washer	1
20	932-021	Front Fork	1
21	932-024	Spacer	3
22	932-022	Seal	2
23	932-023	Bearing	2
24	943-030	Chain Adjuster Bracket	1
25	932-031	Steering Sprocket 96T	1
26	1517	1/4" Key	1
27	932-050	Retainer Ring 9/16" External	2
28	932-042	Thick Slotted Hex Nut 1 1/4 - 12	1
29	720-043	Cotter Pin 1/8" x 1 1/2"	1
30	400-090	3/8" x 1 1/4" Bolt	2
31	932-032	Steering Chain #35 x 100 Pitch	1
32	400-003	5/16" x 1 1/4" Bolt	4
33	832-030	1/4" Drive Pin	1
34	730-046-1	Steering Wheel Cap	1

REAR AXLE ASSEMBLY

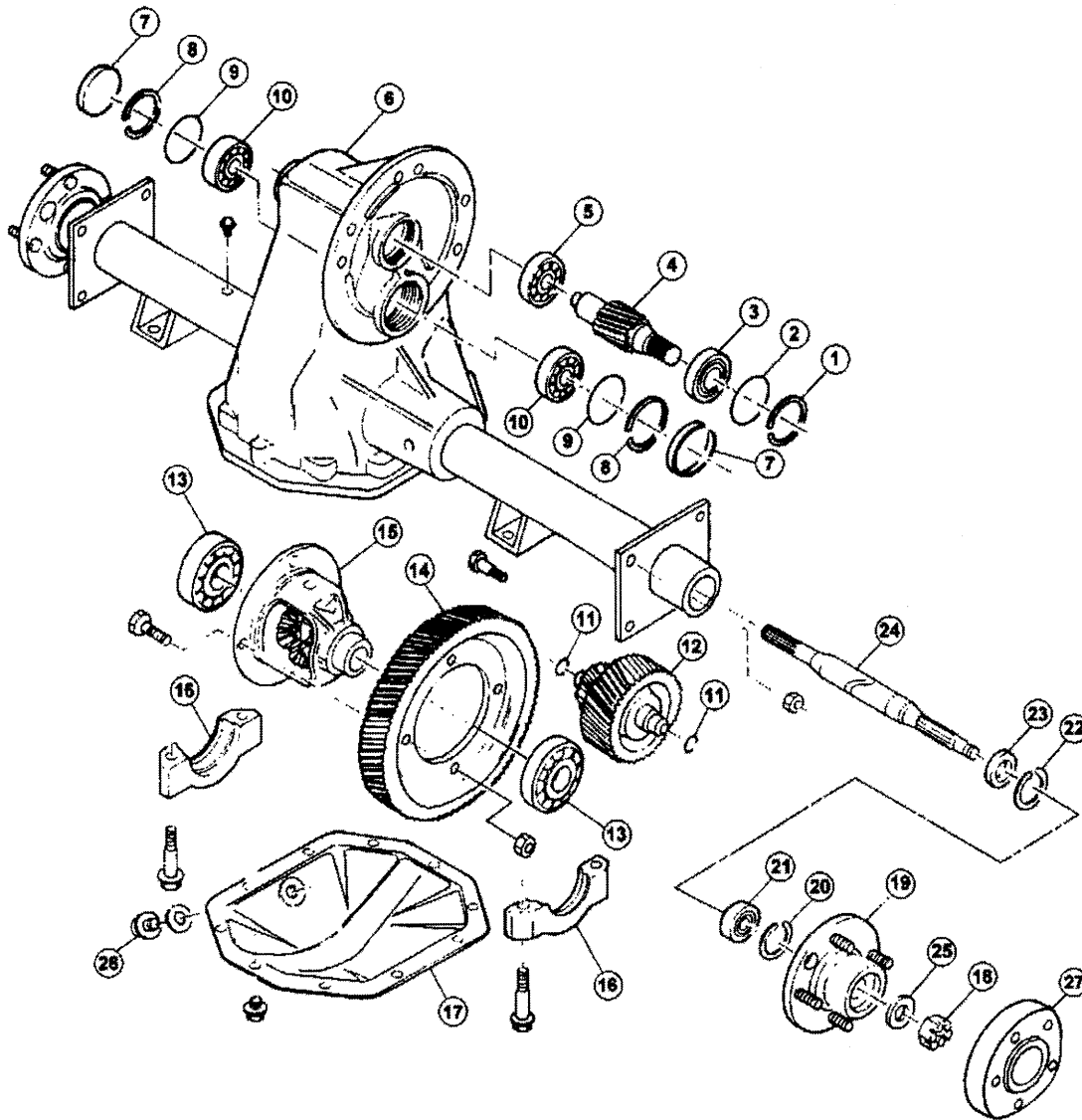

8440 REAR AXLE PARTS LIST

REF#	PART#	DESCRIPTION	QTY.
1	730-089	Snap Ring	1
2	730-087	O-Ring	1
3	730-088	Bearing Ball	1
4*		Input Shaft	1
5	730-086	Bearing Ball	1
6	730-075	Carrier Sub – Assembly	1
7	730-090	Plug, Cup	2
8	730-089	Snap Ring	2
9	730-087	O-Ring	2
10	730-084	Bearing – Ball	2
11	730-083	O-Ring	2
12*		Intermediate Shaft & Gear Assembly	1
13	730-082	Bearing – Ball	2
14*		Gear Output	1
15	730-078	Differential Case Assembly	1
16	730-076	Bearing Cap	2
17	730-093-1	Cover & Plug Assembly	1
18	730-141	Nut Axle Shaft	2
19	730-143-1	Hub	2
20	730-102	Snap Ring	2
21	730-101	Bearing	4
22	730-102	Snap Ring	2
23	730-103	Oil Seal	2
24	730-096	Axle Shaft	2
25	730-142	Axle Washer	2
26	730-093	Plug – Fill	1
27	730-143	Drum	2

*Note: Order as part# 732-006 Gear Kit.

Note: Part# 843-108 is the complete axle.

BRAKE SHOE DRAWING

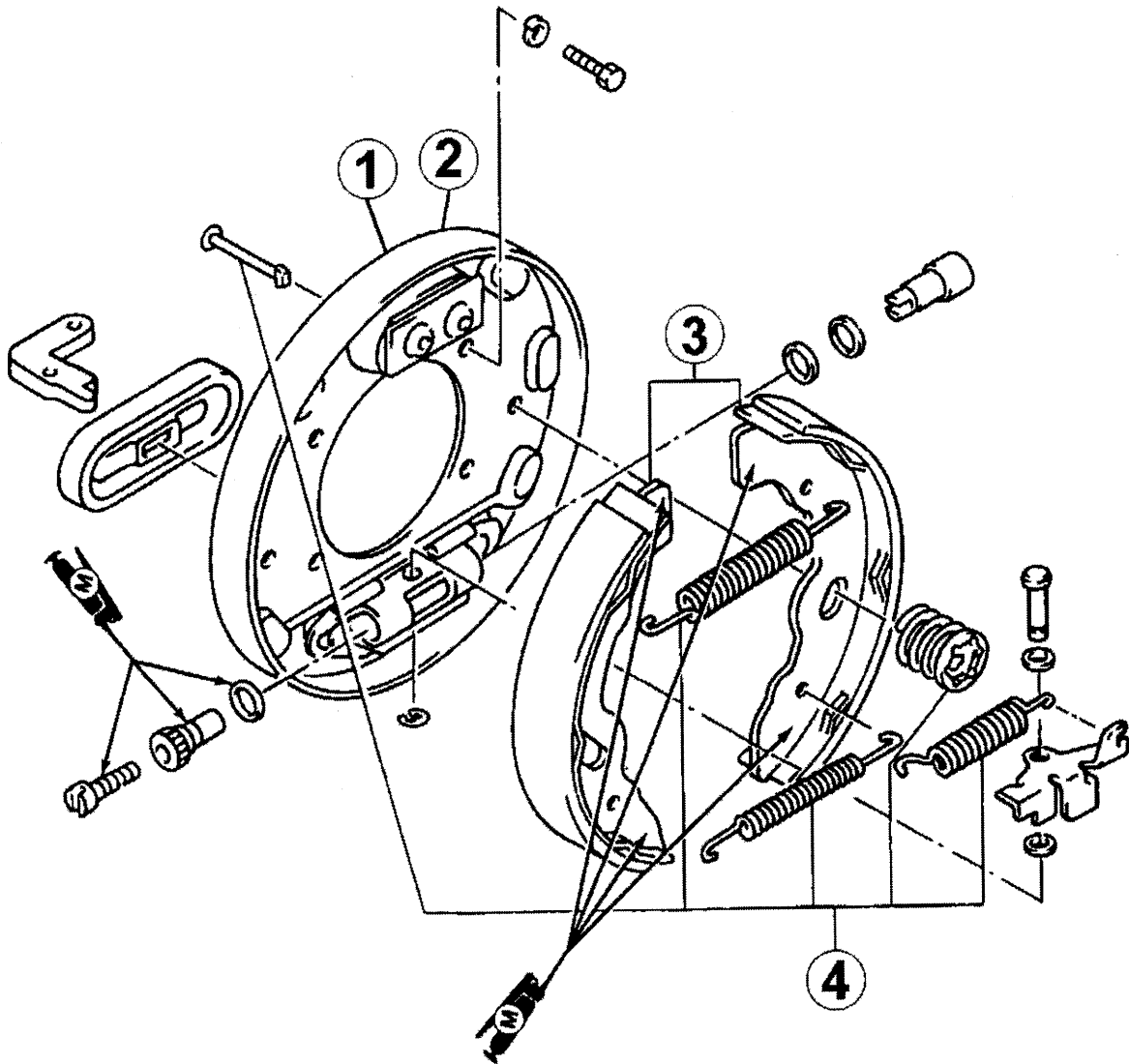

BRAKE SHOE PARTS LIST

REF#	PART#	DESCRIPTION	QTY.
1	730-151	Backing Plate Right	1
2	730-152	Backing Plate Left	1
3	730-147	Brake Shoe Set	1
4	730-146	Spring Kit	1

8440 MOTOR ASSEMBLY DRAWING

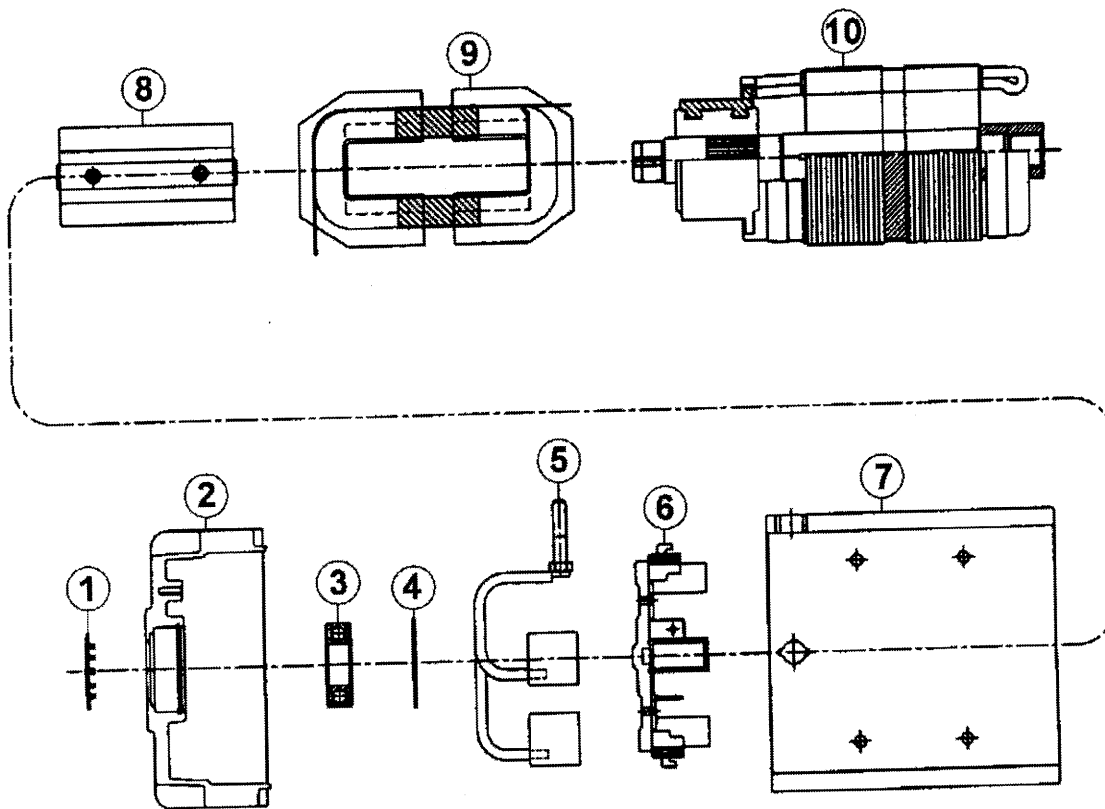

8440 MOTOR ASSEMBLY PARTS LIST

REF#	PART#	DESCRIPTION	QTY.
1	843-132-1	Hole Plug	1
2	843-132-2	Commutator End Head	1
3	843-132-3	Bearing	1
4	843-132-4	Retaining Ring	1
5	843-132-5	Terminal Brush Lead Assembly	1
6	843-132-6	Brush Box Assembly	1
7	843-132-7	Motor Frame	1
8	843-132-8	Pole Shoe Assembly	1
9	843-132-9	Shunt Coil Assembly	1
10	843-132-10	Armature Assembly	1
11	843-132	Electric Motor 48V	1

SAND STAR E 48V WIRING DIAGRAM

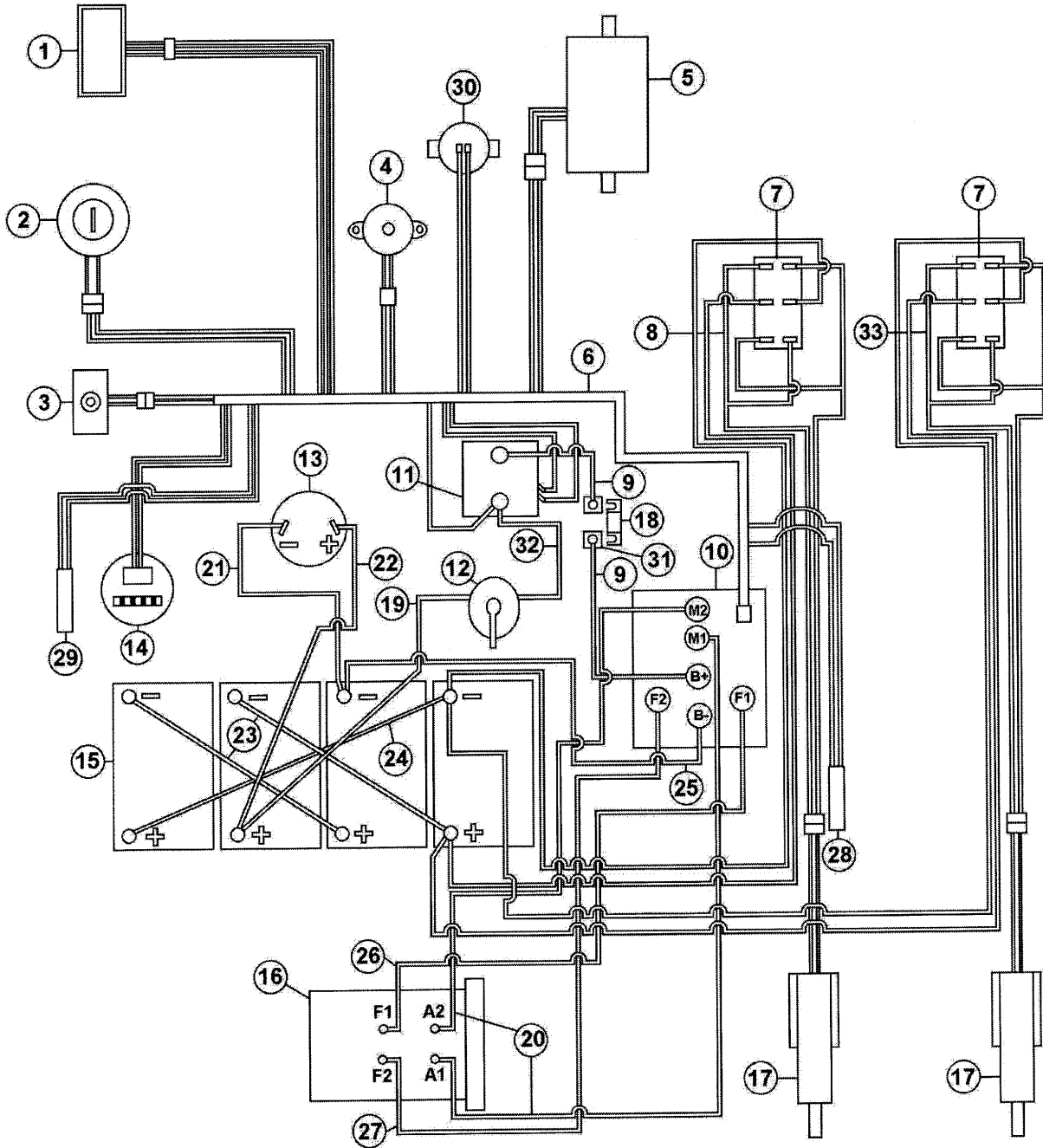

WIRING DIAGRAM PARTS LIST

REF#	PART#	DESCRIPTION	QTY.
1	832-511	Forward/Reverse Switch	1
2	832-514	Key Switch	1
3	2070	Ignition Switch	1
4	832-515	Reverse Beeper	1
5	750-607	Accelerator Switch	1
6	843-134	Main Wiring Harness	1
7	730-220	Actuator Switch	1
8	843-103	Actuator Wiring	1
9	750-622	Battery Cable 2ga 8"	2
10	843-133	Controller	1
11	750-605	Contactora	1
12	750-683	Gray Connector 2ga	2
13	732-017	Charge Plug	1
14	750-609	Battery Gauge	1
15	842-001	US185HC Battery	4
16	843-132	48V Motor	1
17	706-075	Actuator 12V	2
18	750-610	Fuse	1
19	750-690	Wire 2 GA 13" Red	1
20	843-138	Wire 2 GA 23"	2
21	750-687	Wire 8 GA 10" Black	1
22	843-140	Wire 8 GA 24"	1
23	843-141	Battery Cable 2 GA 20" Red	2
24	843-142	Wire 2 GA 28" Red	1
25	750-689	Wire 2 GA 19" Black	1
26	843-136	Wire 6 GA 26" Black	1
27	843-137	Wire 6 GA 23" Black	1
28	843-144	Speed Boss Switch	1
29	843-173	Brake Switch	1
30	932-119-1	Safety Seat Switch	1
31	750-611	Fuse Holder	2
32	750-688	Wire 2ga 8" Black	1
33	750-623	Battery Cable 2ga 11"	1
34	843-104	Actuator Wiring Harness	1

8440 BATTERY INSTALLATION INSTRUCTIONS

1. Loosen the nut on the right rubber bumper, then remove the left rubber bumper. Move the lock bar out of the way.

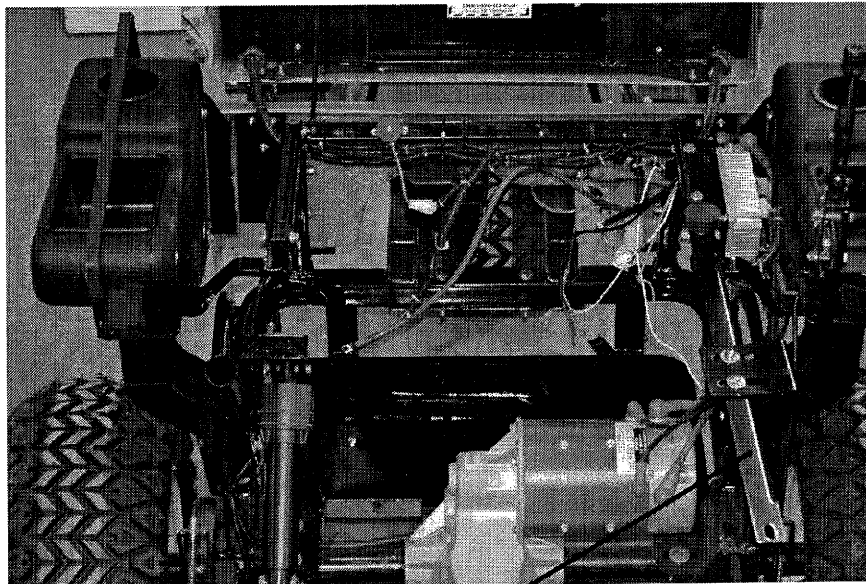

LOOSEN LOCKBAR AND MOVE OVER

2. Remove the battery hold downs.

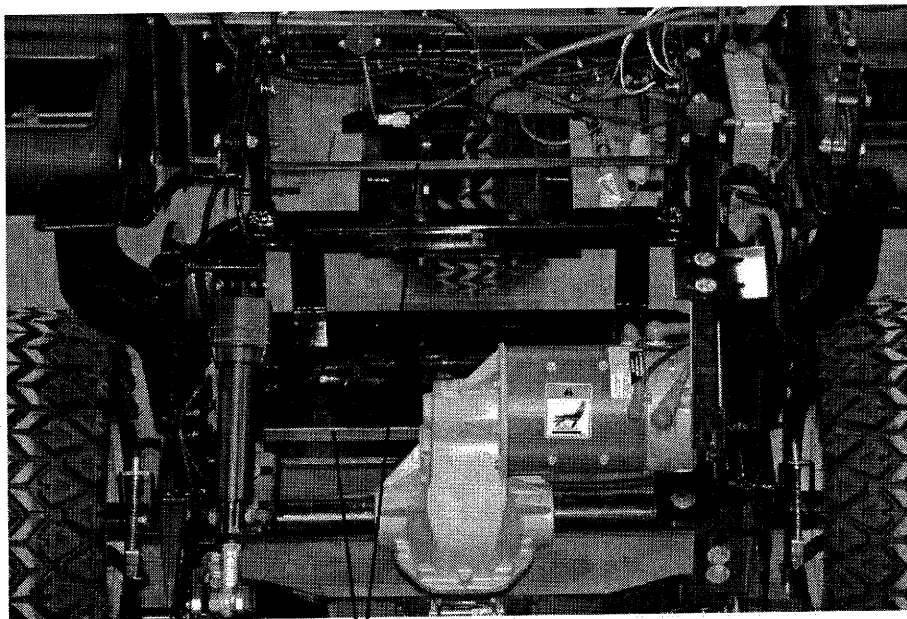

REMOVE BATTERY HOLD DOWNS

3. Before installing the batteries, make sure the cables from the master switch, charge plug, controller and wires from both actuators are moved to a position that allows easy access after the batteries are installed.
4. Install batteries as shown in the diagram.
 1. Battery #1
 2. Battery #2
 3. Battery #4
 4. Battery #3

BATTERY LAY OUT

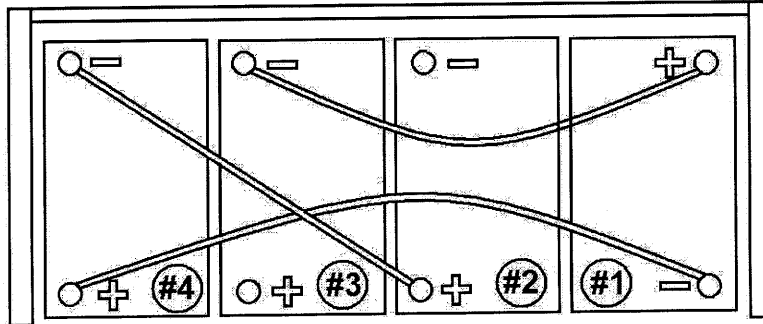

BACK OF UNIT

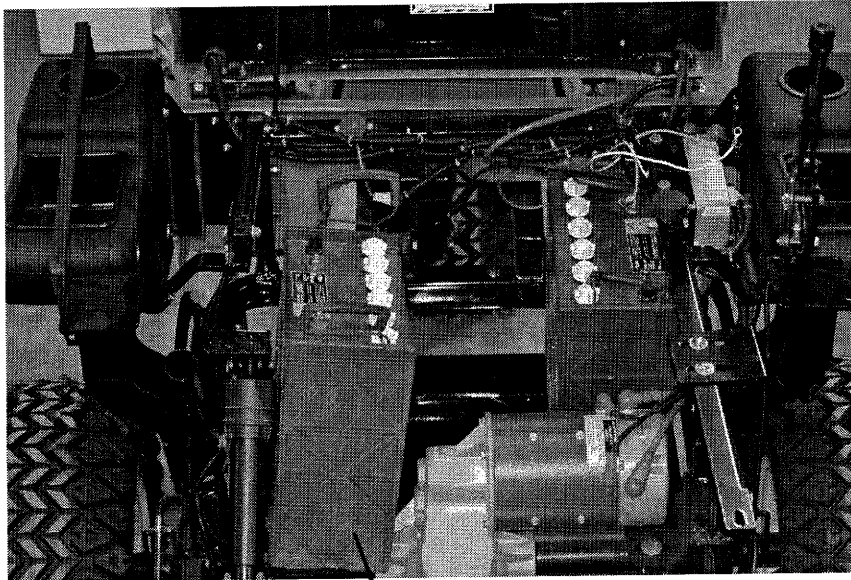

SLIDE BATTERY IN AS SHOWN

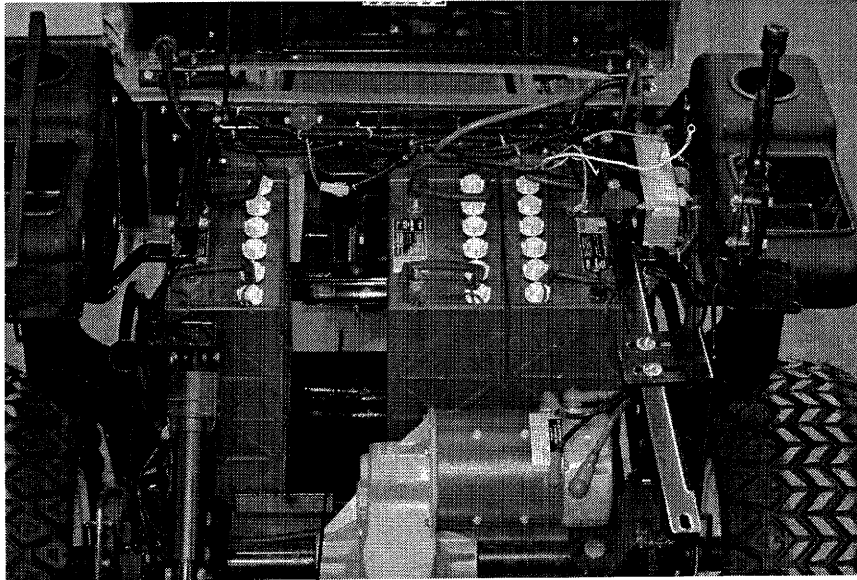

PLACE BATTERIES AS SHOWN TO INSTALL LAST BATTERY

5. Install the battery hold downs.

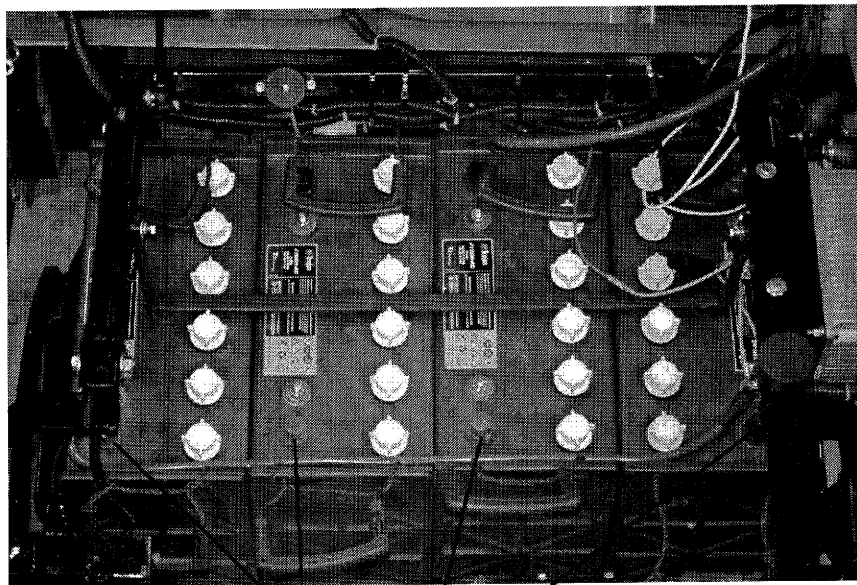

BATTERY PLACEMENT

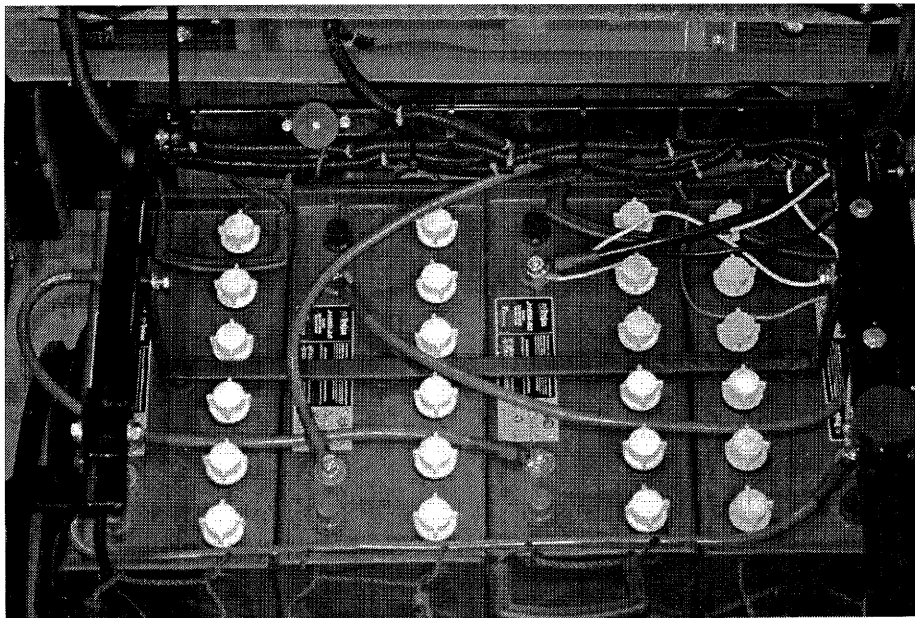

WIRING DIAGRAM

6. Connect the 30" cable from Positive #4 battery to the negative Battery #1, both are fused. Actuator wires connect to the negative Battery #1.
7. Connect (1) of the (2) 25" cables from the negative battery #4 to the positive battery #2.
8. Connect the second 25" cable from the negative battery #3 to the positive battery #1.
9. Connect the white wires from both actuators, ground cables from the charge plug and the controller to the negative battery #2.
10. Connect cable from the master switch to positive #3 battery.
11. Return the lock bar to the correct position. Install rubber bumpers and tighten both bumpers.
12. Turn the master switch to the "ON" position. Turn on the ignition switch and the contactor should click.

42-401 MANUAL LIFT DRAWING

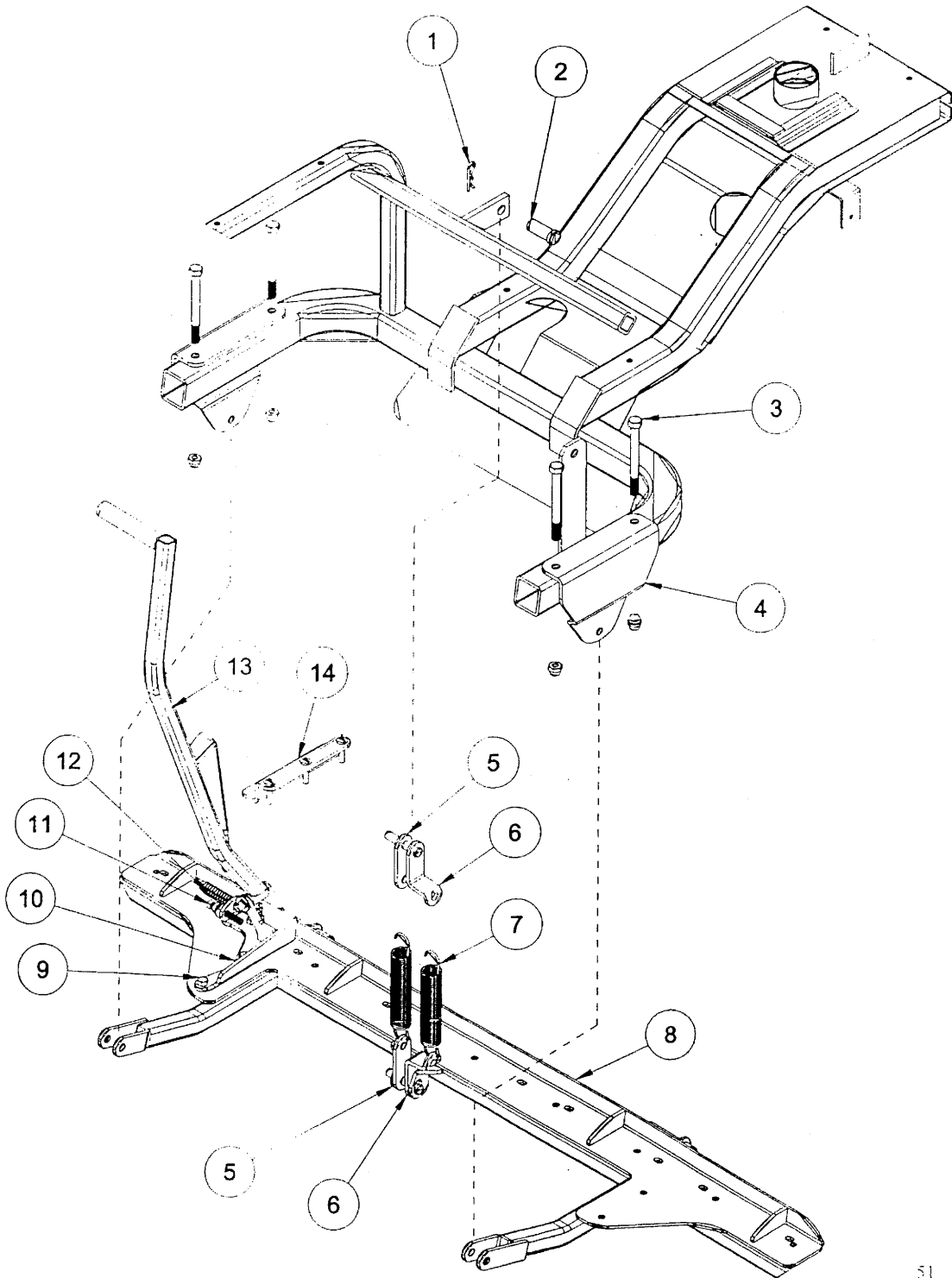

51

42-401 MANUAL LIFT PARTS LIST

REF#	PART#	DESCRIPTION	QTY.
1	HP-18-100	Cotter Pin 1/8" x 1"	3
2	HCP-12-250	Clevis Pin 1/2" x 2 1/2"	3
	HW-12	Washer 1/2"	8
3		Bolt 1/2" – 13 x 5	4
		Lock Nut 1/2 - 13	4
4		Attachment Mount	2
5	42-383	Flat Spring Bracket	2
6	42-384	Offset Spring Bracket	2
7	21-445	Spring	2
8		Attachment Lift	1
9	HB-38-16-125	Bolt 3/8" – 16 x 1 1/4"	3
	HNTL-38-16	Lock Nut 3/8" – 16	3
10	42-382	Lift Handle Mount	1
11	HSSQ-38-16-250	Square Head Set Screw 3/8" – 16 x 2 1/2"	1
12	HB-516-18-400	Bolt 5/16" – 18 x 4"	1
	HW-516	Washer 5/16"	2
	11-055	Die Spring	1
	HNFL-516-18	Flange Whiz Lock Nut 5/16" – 18	1
13	42-381	Attachment Lift Handle	1
	15-019	Round Grip	1
14	42-385	Handle Lock Bracket (Bolts to LH Floorboard)	1
	HSTP-516-18-150	Phillips Machine Screw 5/16" – 18 x 1 1/2"	3
	HW-516	Washer 5/16"	3
	HNTL-516-18	Lock nut 5/16" – 18	3

41-401 MANUAL LIFT PACKING LIST

<u>PART#</u>	<u>DESCRIPTION</u>	<u>QTY.</u>
42-381	Attachment Lift Handle	1
42-382	Lift Handle Mount	1
42-385	Handle Lock Bracket	1

SMALL PARTS BAG

<u>PART#</u>	<u>DESCRIPTION</u>	<u>QTY.</u>
11-055	Die Spring	1
15-019	Round Grip	1
21-445	Spring	2
42-383	Flat Spring Bracket	2
42-384	Offset Spring Bracket	2
HB-38-16-125	Bolt 3/8" – 16 x 1 1/4"	3
HB-516-18-400	Bolt 5/16" – 18 x 4"	1
HCP-12-250	Clevis Pin 1/2" x 2 1/2"	3
HNFL-516-18	Flange Whiz Lock Nut 5/16" – 18	1
HNTL-38-16	Lock Nut 3/8" – 16	3
HNTL-516-18	Lock Nut 5/16" – 18	3
HP-18-100	Cotter Pin 1/8" x 1"	3
HSSQ-38-16-250	Square Head Set Screw 3/8" – 16 x 2 1/2"	1
HSTP-516-18-150	Phillips Machine Screw 5/16" – 18 x 1 1/2"	3
HW-12	Washer 1/2"	8
HW-516	Washer 5/16"	5

42-011 – AB ALUMINUM SAND PLOW DRAWING

42-011 – SB STEEL SAND PLOW DRAWING

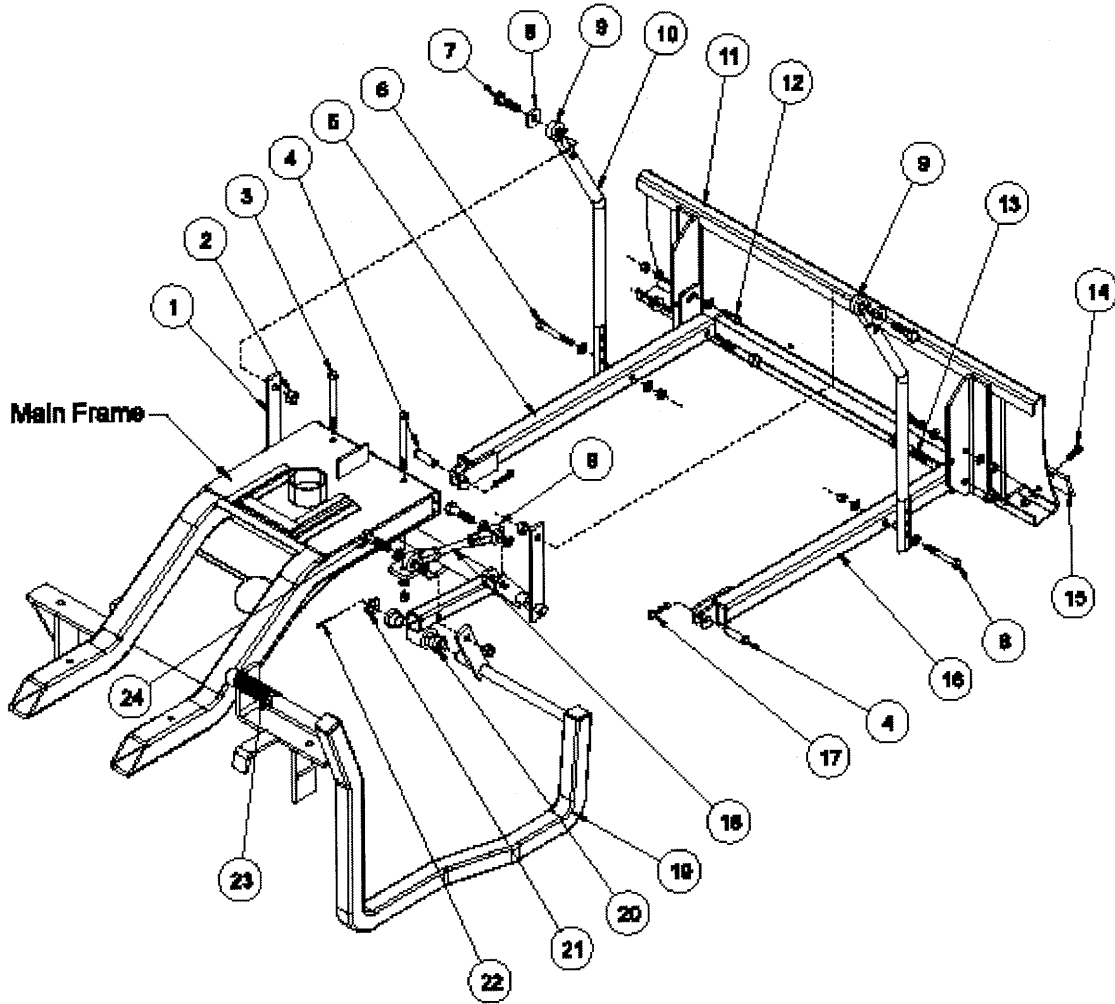

42-011 SAND PLOW PARTS LIST

REF#	PART#	DESCRIPTION	QUANTITY
1	42-092	Lift Assembly (includes Ref# 20)	1
2	HNTL-12-13	Lock Nut 1/2- 13	2
3	HB-38-16-350	Bolt 3/8- 16 x 3 1/2 (part of main frame)	2
	HWL-38	Lock Washer 3/8	2
	HN-38-16	Nut 3/8- 16	2
4	HCP-12-150	Clevis Pin 1/2 x 1 1/2	2
5	27-049	Left Pusher Bar	1
6	HB-38-16-300	Bolt 3/8- 16 x 3	2
	HW-38	Washer 3/8	4
	HNTL-38-16	Lock Nut 3/8- 16	2
7	HB-12-13-200	Bolt 1/2- 13 x 2	2
8	HMB-12-14	Machine Bushing 1/2 x 14GA	8
9	80-006	Rod End	4
	HNJ-12-20	Jam Nut 1/2- 20	4
10	27-073	Lift Rod	2
11	27-017	Aluminum Sand Plow Blade	1
	13-352	Steel Sand Plow Blade	1
12	HB-38-16-100	Bolt 3/8- 16 x 1	2
	HW-38	Washer 3/8	2
	HWL-38	Lock Washer 3/8	2
	HN-38-16	Nut 3/8- 16	2
13	HB-12-13-300	Bolt 1/2- 13 x 3	2
	HNTL-12-13	Lock Nut 1/2- 13	2
14	HB-38-16-100	Bolt 3/8- 16 x 1	4
	HWL-38	Lock Washer 3/8	4
	HN-38-16	Nut 3/8- 16	4
15	13-167	Wear Blade	1
16	27-050	Right Pusher Bar	1
17	HHP-18	Bridge Pin 1/8	2
18	42-094	Rod	1
19	42-093	Lift Handle	1
20	18-221	Flange Bushing	2
21	HMB-34-14	Machine Bushing 3/4- 14GA	1
22	HP-18-150	Cotter Pin 1/8 x 1 1/2	1
23	15-019	Grip	1
24	HB-12-13-200	Bolt 1/2- 13 x 2	2

INSTALLATION INSTRUCTIONS

- Assemble the pusher bars (Ref 5 and 16) to the plow (Ref 11) using hardware (Ref 12 & 13). There are 2 holes to bolt the hardware in. Using hole closest to the blade will result in a shallow cut, whereas using the hole furthest from the blade will result in a deeper cut. The slot on the pusher bar is for fine tuned adjustment.
- Assemble the lift assembly (Ref 1) to the main frame using the two studs that are under the frame and below the front of the console.
- Attach the lift handle (Ref 19) to the lift assembly using cotter pin and machine bushing (Ref 21 & 22). Using rod and yoke (Ref 18 & 9) attach the handle to the lift assembly.
- Put rod ends (Ref 9) onto lift rods (Ref 10) with jam nut first. Adjust to equal lengths. Bolt lift rods to lift arms with ball joints to the outside. Bolt from outside with the 1/2" machine bushing between rod end and lift arm and the 1/2-13 nylon lock nut on the inside. Use (Ref 7) hardware.
- Slide Plow under machine and connect to machine. Use clevis pin and bridge pin (Ref 4 & 17).
- Lift up the plow. Using the top hole in the lift rod as a starting point hook on the pusher bars. Use (Ref 6) hardware. The three holes in the lift rods are for adjusting the hand lever. The top hole moves the lever forward and holds the blade with the most clearance. Each hole down moves the lever to the rear of the machine and decreases blade clearance by approximately one inch.
- For fine tuning of blade height off ground twist rod end (Ref 9) on rod (Ref 18). Twisting the rod end out will increase down pressure. Twisting the rod end onto the rod will decrease down pressure.



42-136 60" SAND PLOW DRAWING

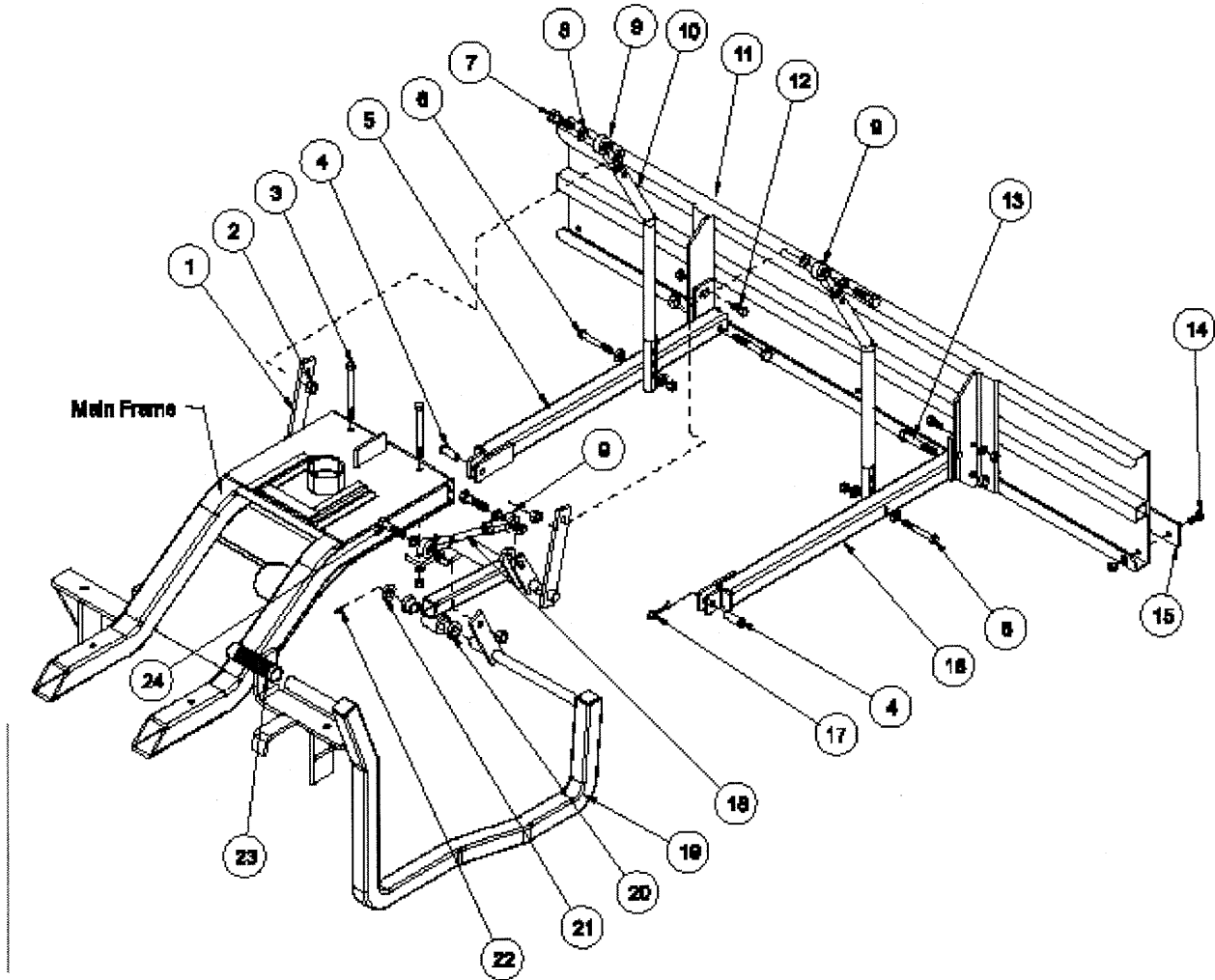

42-136 60" PLOW PARTS LIST

REF#	PART#	DESCRIPTION	QUANTITY
1	42-092	Lift Assembly (includes Ref# 20)	1
2	HNTL-12-13	Lock Nut 1/2 - 13	4
3	HB-38-16-350	Bolt 3/8 - 16 x 3 1/2 (part of main frame)	2
	HWL-38	Lock Washer 3/8	2
	HN-38-16	Nut 3/8 - 16	2
4	HCP-12-150	Clevis Pin 1/2 x 1 1/2	2
5	27-049	Left Pusher Bar	1
6	HB-38-16-300	Bolt 3/8 - 16 x 3	2
	HW-38	Washer 3/8	4
	HNTL-38-16	Lock Nut 3/8 - 16	2
7	HB-12-13-200	Bolt 1/2 - 13 x 2	2
8	HMB-12-14	Machine Bushing 1/2 x 14GA	8
9	80-006	Rod End	4
	HNJ-12-20	Jam Nut 1/2 - 20	4
10	27-073	Lift Rod	2
11	35-011	Aluminum Plow Blade 60"	1
12	HB-38-16-100	Bolt 3/8 - 16 x 1	2
	HW-38	Washer 3/8	2
	HWL-38	Lock Washer 3/8	2
	HN-38-16	Nut 3/8 - 16	2
13	HB-12-13-300	Bolt 1/2 - 13 x 3	2
	HNTL-12-13	Lock Nut 1/2 - 13	2
14	HB-38-16-100	Bolt 3/8 - 16 x 1	5
	HWL-38	Lock Washer 3/8	5
	HN-38-16	Nut 3/8 - 16	5
15	35-012	Wear Blade	1
16	27-050	Right Pusher Bar	1
17	HHP-18	Bridge Pin 1/8	2
18	42-094	Rod	1
19	42-093	Lift Handle	1
20	18-221	Flange Bushing	2
21	HMB-34-14	Machine Bushing 3/4 - 14GA	1
22	HP-18-150	Cotter Pin 1/8 x 1 1/2	1
23	15-019	Grip	1
24	HB-12-13-200	Bolt 1/2 - 13 x 2	2

INSTALLATION INSTRUCTIONS

- Assemble pusher bars (Ref 5 and 16) to plow (Ref 11) using hardware (Ref 12 & 13). There are 2 holes to bolt the hardware in. Using hole closest to the blade will result in a shallow cut, whereas using the hole furthest from the blade will result in a deeper cut. The slot on the pusher bar is for fine tuned adjustment.
- Assemble the lift assembly (Ref 1) to the main frame using the two studs that are under the frame and below the front of the console.
- Attach the lift handle (Ref 19) to the lift assembly using cotter pin and machine bushing (Ref 21 & 22). Using rod and yoke (Ref 18 & 9) attach the handle to the lift assembly.
- Put rod ends (Ref 9) onto lift rods (Ref 10) with jam nut first. Adjust to equal lengths. Bolt lift rods to lift arms with ball joints to the outside. Bolt from outside with the 1/2" machine bushing between rod end and lift arm and the 1/2-13 nylon lock nut on the inside. Use (Ref 7) hardware.
- Slide plow under machine and connect to machine. Use clevis pin and bridge pin (Ref 4 & 17).
- Lift up the plow. Using the top hole in the lift rod as a starting point hook on the pusher bars. Use (Ref 6) hardware. The three holes in the lift rods are for adjusting the hand lever. The top hole moves the lever forward and holds the blade with the most clearance. Each hole down moves the lever to the rear of the machine and decreases blade clearance by approximately one inch.
- For fine tuning of blade height off ground twist rod end (Ref 9) on rod (Ref 18). Twisting the rod end out will increase down pressure. Twisting the rod end onto the rod will decrease down pressure.

42-223 ADJUSTABLE DISC EDGER DRAWING

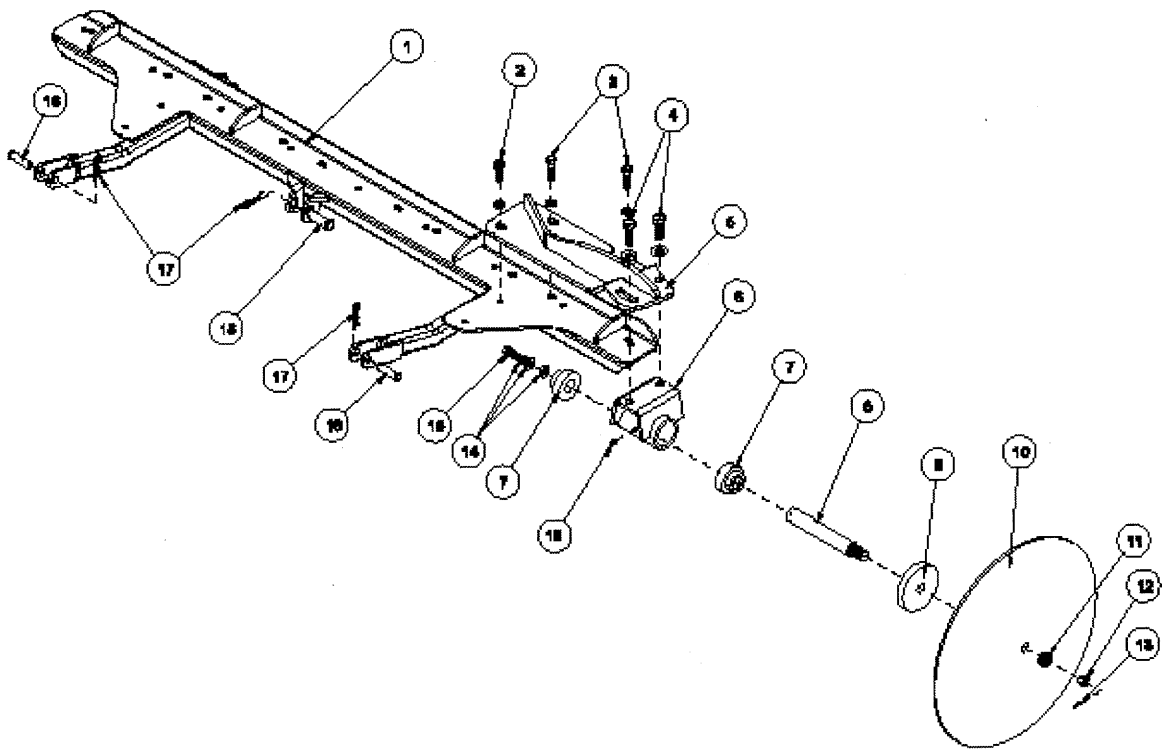

42-223 ADJUSTABLE DISC EDGER PARTS LIST

REF#	PART#	DESCRIPTION	QUANTITY
1	42-203	Attachment Lift Assembly	1
2	HB-38-16-125	Bolt $\frac{3}{8}$ - 16 x $1\frac{1}{4}$	1
	HW-38	Washer $\frac{3}{8}$	1
	HNTL-38-16	Lock Nut $\frac{3}{8}$ - 16	1
3	HB-38-16-150	Bolt $\frac{3}{8}$ - 16 x $1\frac{1}{2}$	2
	HW-38	Washer $\frac{3}{8}$	2
	HNTL-38-16	Lock Nut $\frac{3}{8}$ - 16	2
4	HB-12-13-150	Bolt $\frac{1}{2}$ - 13 x $1\frac{1}{2}$	2
	HW-12	Washer $\frac{1}{2}$	2
	HNTL-12-13	Lock Nut $\frac{1}{2}$ - 13	2
5	42-224	Edger Mount	1
6	13-203	Spindle	1
7	21-169	Bearing and Collar	2
8	13-206	Spindle Shaft	1
9	13-205	$\frac{1}{2}$ Disc Flange	1
10	13-204	Disc	1
11	HMB-34-10	Machine Bushing $\frac{3}{4}$ x 10GA	4
12	HNA-34-16	Axle Nut $\frac{3}{4}$ - 16	1
13	HP-18-150	Cotter Pin $\frac{1}{8}$ x $1\frac{1}{2}$	1
14	HWL-38	Washer $\frac{3}{8}$	1
	HW-516	Washer $\frac{5}{16}$	1
	HW-716	Washer $\frac{7}{16}$	1
15	HB-38-16-100	Bolt $\frac{3}{8}$ - 16 x 1	1
16	HCP-12-200	Clevis Pin $\frac{1}{2}$ x 2	2
17	HHP-18	Bridge Pin $\frac{1}{8}$	3
18	HCP-58-250	Clevis Pin $\frac{5}{8}$ x $2\frac{1}{2}$	1
19	HG-14-28-180	Grease Fitting $\frac{1}{4}$ - 28 x 180	1

INSTALLATION INSTRUCTIONS

- For initial assembly, bolt spindle assembly (Ref 6) to the edger mount (Ref 5). Use the $\frac{1}{2}$ - 13 bolts, washers and lock nuts (Ref 4) to hold in place.
- Make sure the $\frac{1}{2}$ " disc flange (Ref 9) is on the spindle shaft (Ref 8) up to the shoulder. Then place the disc (Ref 10) onto the shaft, curved towards the spindle housing, followed by four machine bushings (Ref 11), and the axle nut (Ref 12).
- Tighten axle nut and slide in the cotter pin (Ref 13).
- The edger mount mounts onto the attachment lift assembly (Ref 1). Use the $\frac{3}{8}$ bolts, washers and lock nuts (Ref 2 and 3) with the $1\frac{1}{4}$ " bolt going into the last hole on the mount plate.
- The Edger mounts under the center of the trap rake.
- Place the handle and linkage onto the empty linkage port of the two bank valve on the machine.
- Start the engine and lower the cylinder for the attachment lift FULLY. Stop engine.
- Slide Edger under the trap rake from the right side.
- Position the lift arms on the attachment lift assembly to the lift brackets on the machine. Hold in place with $\frac{1}{2}$ x 2 clevis pin and bridge pins (Ref 16 and 17).
- Attach the cylinder to the center tab on the attachment lift assembly using the $\frac{5}{8}$ x $2\frac{1}{2}$ clevis pin and bridge pin (Ref 17 and 18).
- Start engine and test lift and Edger to make sure all works well.

42-750 CART PATH AND SIDEWALK EDGER DRAWING

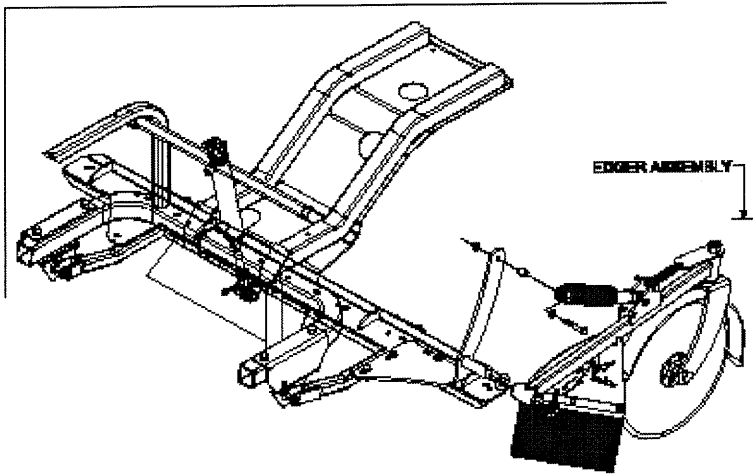
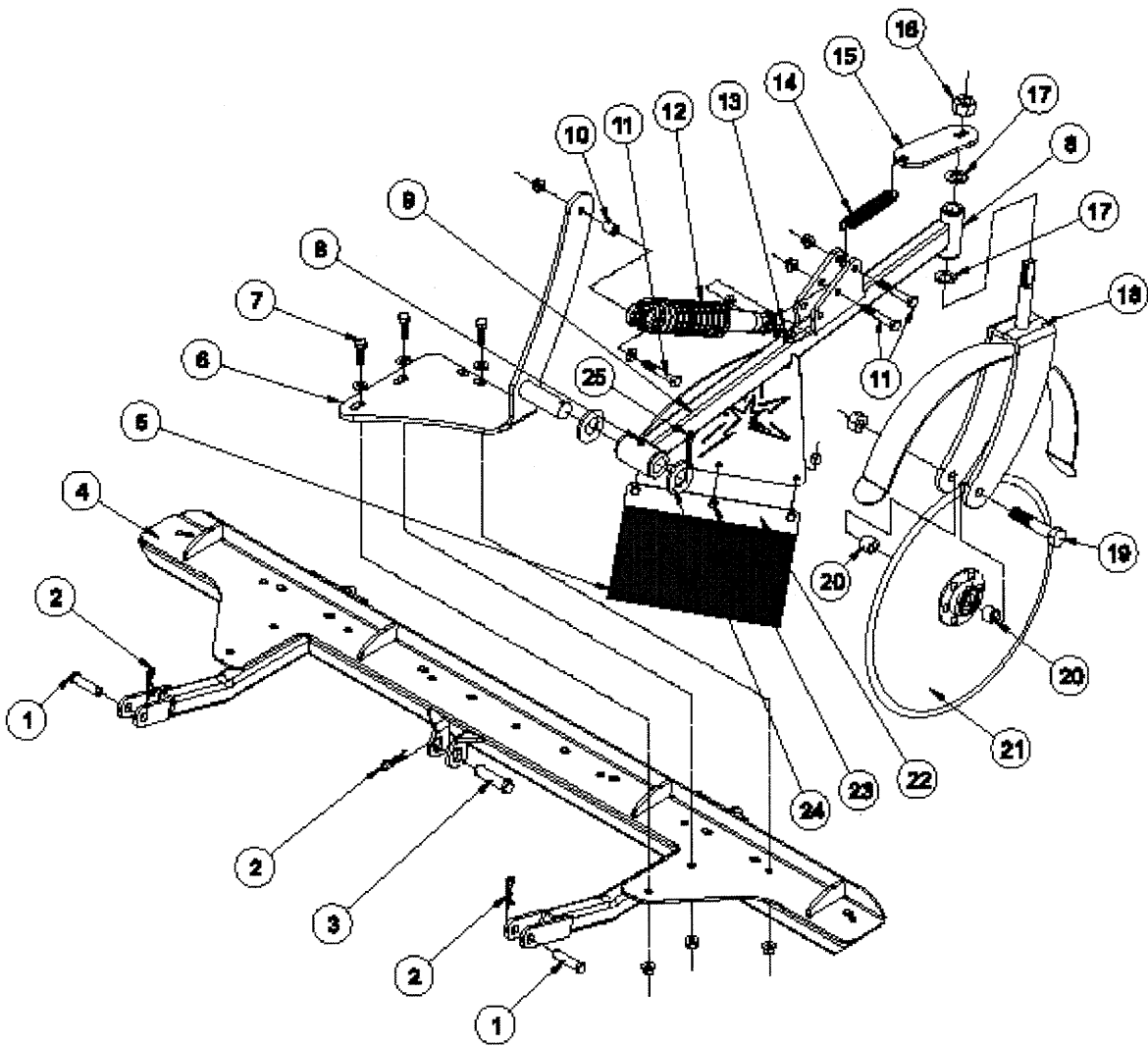

42-750 CART PATH AND SIDEWALK EDGER PARTS LIST

REF#	PART#	DESCRIPTION	QUANTITY
1	HCP-12-200	Clevis Pin, 1/2 x 2	2
2	HHP-18-100	Bridge Pin, 1/8 x 1	4
3	HCP-58-250	Clevis Pin, 3/8 x 2 1/2	1
4	42-203	Attachment Lift Assembly	1
5	42-758	Brush	1
6	42-754	Edger Mount	1
7	HB-38-16-125	Bolt, 3/8 - 16 x 1 1/4	3
	HNFL-38-16	Flange Whiz-Lock Nut, 3/8 - 16	3
	HW-38	Flat Washer, 3/8	3
8	HG-14-28-180	Grease Fitting, 1/4 - 28 x 180*(Part of 42-755)	1
9	42-755	Edger Arm	1
10	10-134	Spacer	1
11	HB-38-16-250	Bolt, 3/8 - 16 x 2 1/2	3
	HNFL-38-16	Flange Whiz-Lock Nut, 3/8 - 16	3
	HW-38	Flat Washer, 3/8	1
12	60-123	Shock Absorber	1
13	HW-38	Flat Washer, 3/8	4
14	48-109	Spring	1
15	42-757	Spring Mount	1
16	HNTL-34-16	Lock Nut, 3/4 - 16	1
17	HMB-34-10	Machine Bushing, 3/4 x 10GA	2
18	42-756	Edger Fork	1
19	HB-58-11-325	Bolt, 5/8 - 11 x 3 1/4	1
	HNCL-58-11	Center Lock Nut, 5/8 - 11	1
20	76-298	Spacer	2
21	42-752	Edger Blade	1
22	42-759	Brush Holder	1
23	HB-14-20-075	Bolt, 1/4 - 20 x 3/4	3
	HNFL-14-20	Flange Whiz-Lock Nut, 1/4 - 20	3
24	HMB-100-14	Machine Bushing, 1 x 14GA	2

INSTALLATION INSTRUCTIONS

For your convenience and ease of installation, a major set of components are pre-assembled at the factory. This is the "Edger Assembly" and includes Reference #'s 11 thru 23.

- Slide attachment lift assembly (Ref 4) under machine and attach using (2) 1/2 x 2" clevis pins and 1/8" bridge pins (Ref 1 and 2). Connect the free end of the hydraulic cylinder to the attachment lift assembly (Ref 4) as illustrated using the 3/8 x 2 1/2 clevis pin and 1/8" bridge pin (Ref 3 and 2).
- Attach the edger mount (Ref 6) to the attachment lift assembly (Ref 4) using (3) 3/8 - 16 x 1 1/4 bolts, 3/8 flat washers & 3/8 - 16 whiz-lock nuts (Ref 7).
- Now slide (1) 1" machine bushing (Ref 24) on the edger mount's (Ref 6) pin. Next install the "Edger Assembly" (see sidebar) onto the pin. Place the second 1" machine bushing (Ref 24) on the pin. Secure with a 1/8" ridge pin (Ref 2).
- Slide (1) 3/8" flat washer onto (1) 3/8 - 16 x 2 1/2 bolt & insert this in the free end of the shock absorber (Ref 12). Next, slide the spacer (Ref 10) onto the bolt and use (1) 3/8 - 16 whiz-lock nut to secure the shock absorber (Ref 12) to the edger mount (Ref 6) as illustrated.
- Grease all grease fittings (Ref 8) and check all fasteners for proper installation.

42-008 SAND CULTIVATOR DRAWING

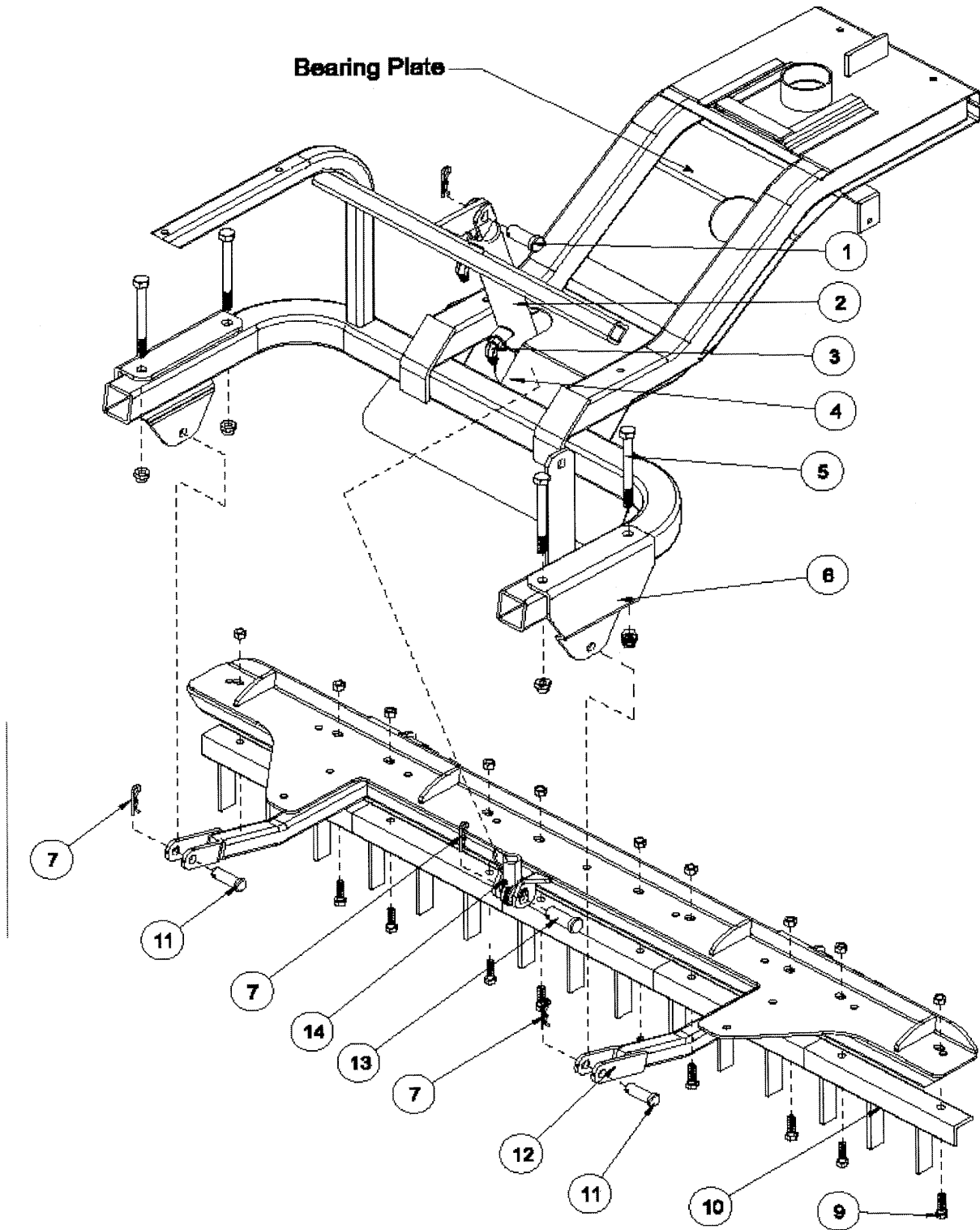

42-008 SAND CULTIVATOR PARTS LIST

REF#	PART#	DESCRIPTION	QTY
1	HCP-58-175	Clevis Pin $\frac{5}{8}$ - $1\frac{3}{4}$	1
2	10-135	Hydraulic Cylinder	1
3	18-168	90° Elbow	2
4	42-217	Cylinder Mount	1
5	HB-12-13-500	Bolt $\frac{1}{2}$ - 13 x 5	4
	HNTL-12-13	Lock Nut $\frac{1}{2}$ - 13	4
6	42-015	Attachment Mount	2
*7	HHP-18	Bridge Pin $\frac{1}{8}$	3
*9	HB-38-16-125	Bolt $\frac{3}{8}$ - 16 x $1\frac{1}{4}$	10
	HNTL-38-16	Lock Nut $\frac{3}{8}$ - 16	10
*10	42-038	Tine Segment	5
*11	HCP-12-200	Clevis Pin $\frac{1}{2}$ x 2	2
*12	42-203	Attachment Lift	1
*13	HCP-58-250	Clevis Pin $\frac{5}{8}$ x $2\frac{1}{2}$	1
14	18-154	Rod End	1
*	42-008	Sand Cultivator (all other parts reference only)	

INSTALLATION INSTRUCTIONS

1. Install valve handle with linkage (13-672) onto valve.
2. Remove the cylinder mount (Ref 4) from the machine.
3. Tine Segments (Ref 10) should be bolted to the attachment lift (Ref 12). Attach the attachment lift to (Ref 12) attachment mount using (Ref 11 & 7) clevis pin and bridge pin.
4. Lift attachment lift up or extend cylinder so rod end (Ref 14) lines up with the holes on the center of the attachment lift. Use clevis pin and bridge pin (Ref 7 and 13) to fasten cylinder to sand cultivator.
6. Turn machine on and test for proper operation.

42-010 CONSTRUCTION LEVELING BLADE DRAWING

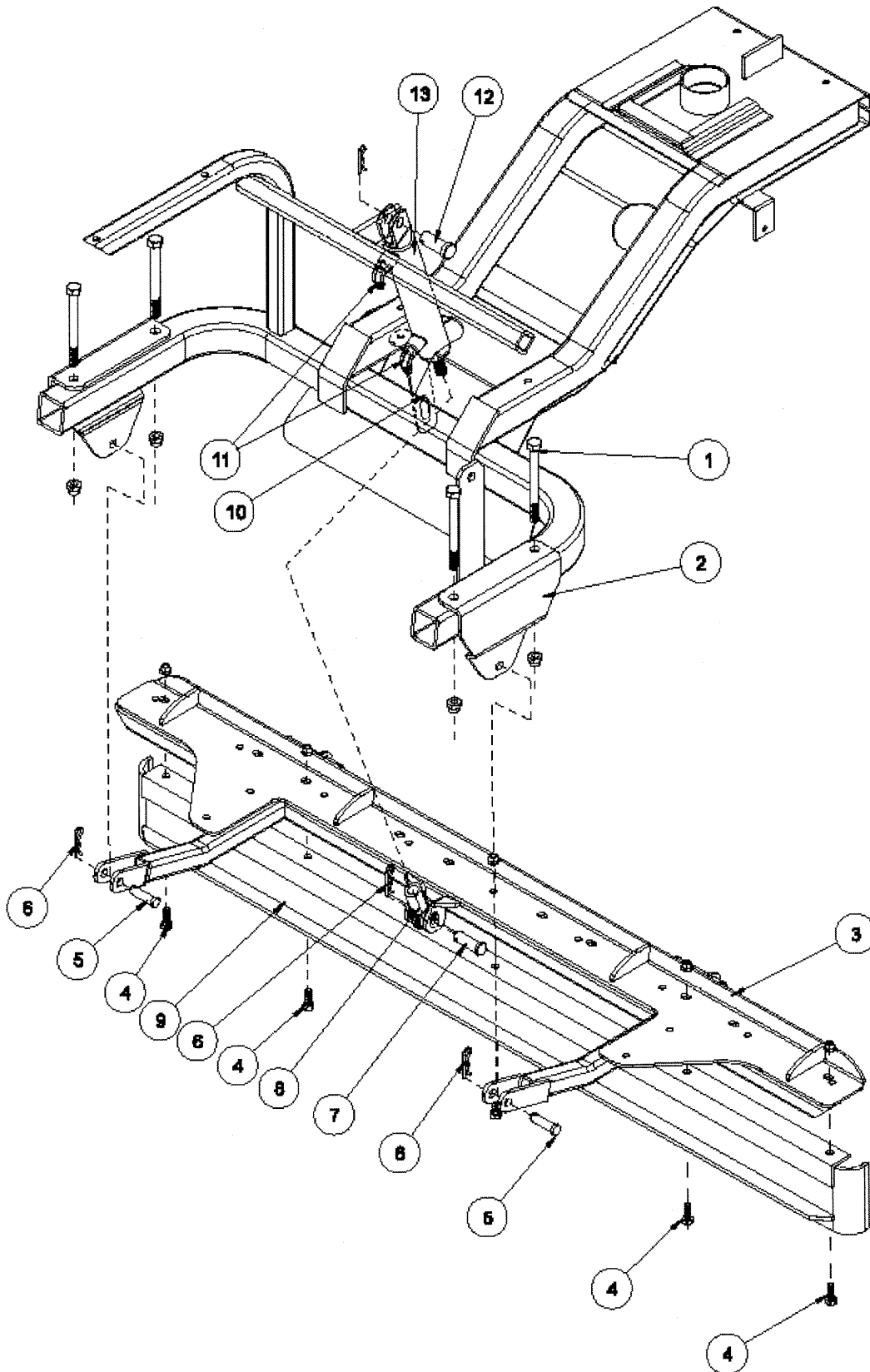

42-010 CONSTRUCTION LEVELING BLADE PARTS LIST

REF#	PART#	DESCRIPTION	QUANTITY
1	HB-12-13-500	Bolt 1/2 - 13 x 5	4
	HNTL-12-13	Lock Nut 1/2 - 13	4
2	42-015	Attachment Mount	2
*3	42-203	Attachment Lift	1
*4	HB-38-16-100	Bolt 3/8 - 16 x 1	5
	HNTL-38-16	Lock Nut 3/8 - 16	5
*5	HCP-12-200	Clevis Pin 1/2 x 2	2
*6	HHP-18	Bridge Pin 1/8	3
*7	HCP-58-250	Clevis Pin 5/8 x 2 1/2	1
8	18-154	Rod End	1
*9	42-097	Leveling Blade	1
10	42-217	Cylinder Mount	1
11	18-168	90° Elbow	2
12	HCP-34-175	Clevis Pin 3/4 - 1 3/4	1
13	10-135	Hydraulic Cylinder	1
*	42-010	Construction Leveling Blade (all other parts are reference only)	

INSTALLATION INSTRUCTIONS

1. Remove the cylinder mount (Ref 10) from the machine.
2. Bolt leveling blade (Ref 9) to attachment lift (Ref 3) using five 3/8 - 16 x 1 bolts and five 3/8 - 16 lock nuts as shown on drawing.
3. Attach the attachment lift to attachment mount (Ref 3) using clevis pin and bridge pin (Ref 5 and 6).
4. Lift attachment lift up or extend cylinder so rod end (Ref 8) lines up with the holes on the center of the attachment lift. Use 5/8 x 2 1/2 clevis pin and bridge pin (Ref 6 & 7) to fasten cylinder to cultivator.
5. Turn machine on and test for proper operation.

42-210 GRADER BLADE DRAWING

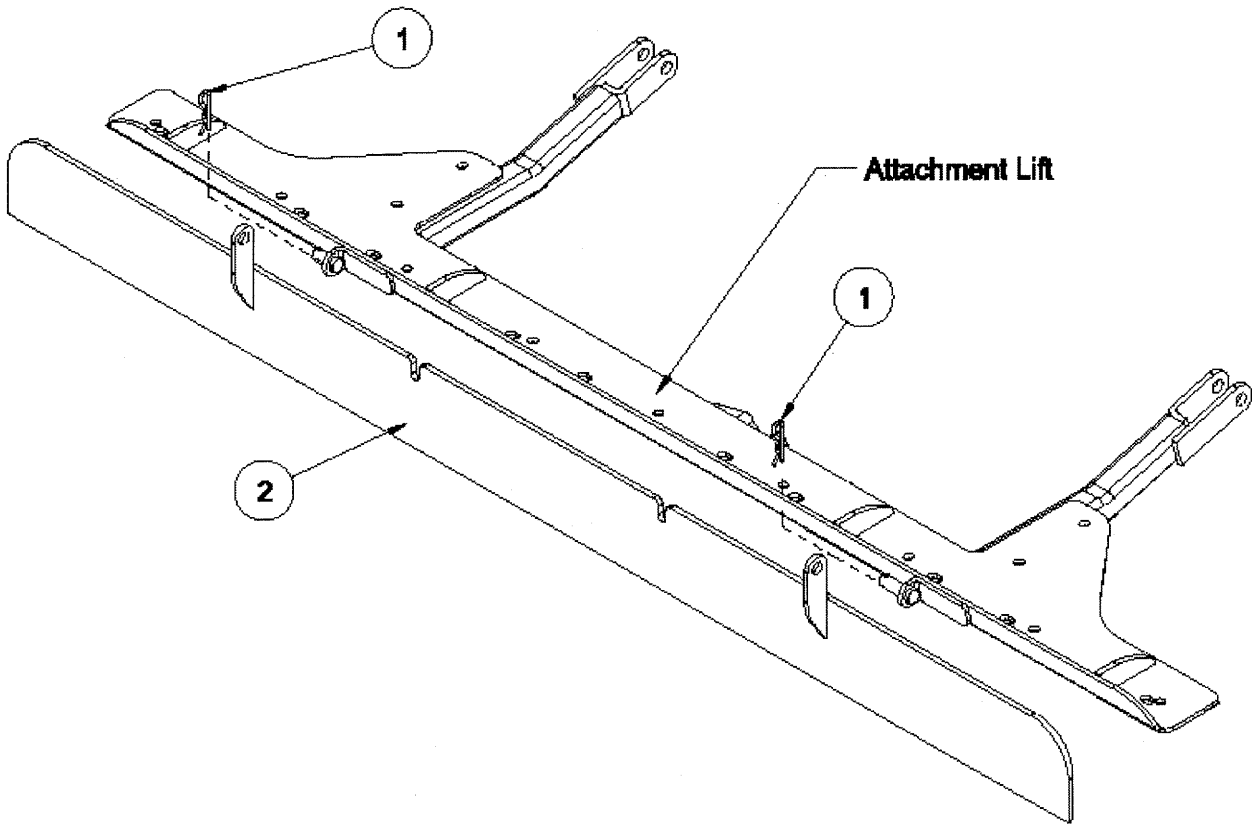

BLADE CLIP DRAWING

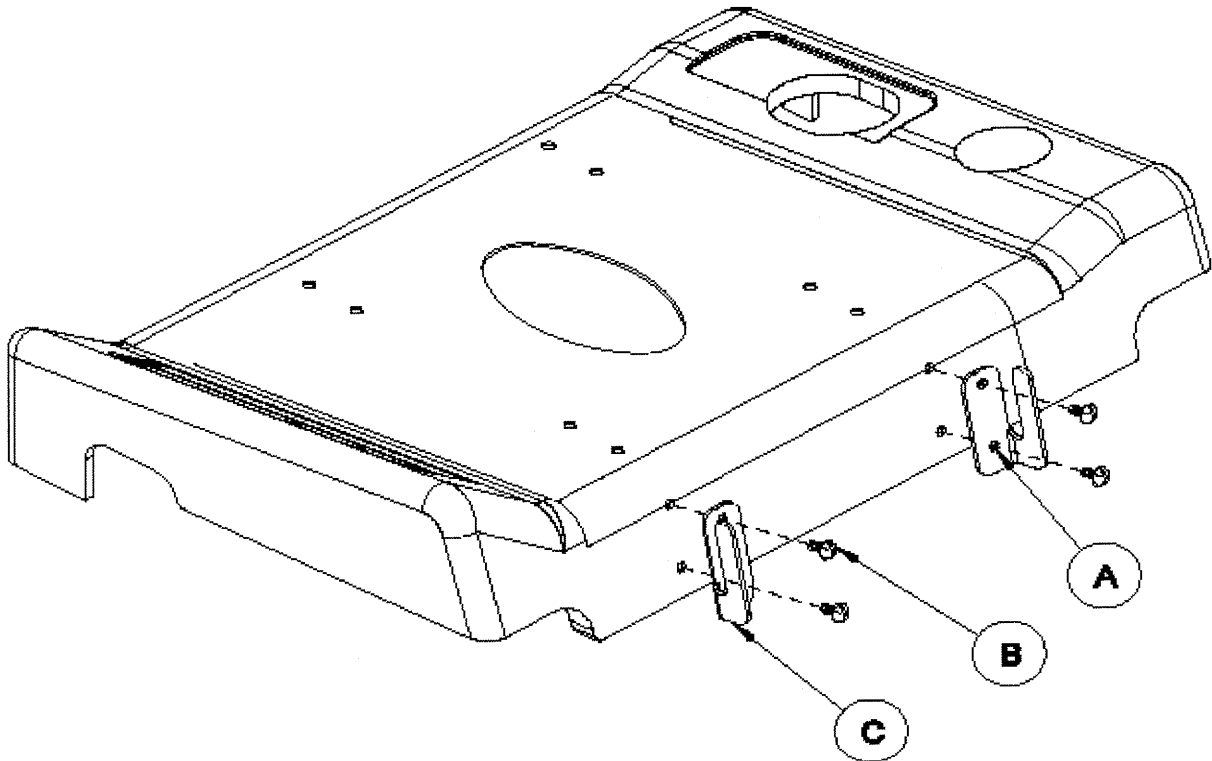

42-210 GRADER BLADE PARTS LIST

REF#	PART#	DESCRIPTION	QTY
1	HHP-18	Bridge Pin $\frac{1}{8}$	2
2	42-207	Grader Blade	1
A	42-211	Right Blade Clip	1
B	HST-516-18-075	Truss Head Screw $\frac{5}{16}$ - 18 x $\frac{3}{4}$	4
	HWL-516	Lock Washer $\frac{5}{16}$	4
	HN-516-18	Nut $\frac{5}{16}$ - 18	4
C	42-216	Left Blade Clip	1

INSTALLATION INSTRUCTIONS

1. Install Grader Blade to Attachment Lift by sliding tabs onto clevis pins and secure with bridge pins.
2. Install right and left blade clips (Ref A and C) on seat panel. If holes need to be drilled, drill (4) $\frac{11}{32}$ holes 5.75" off each side of center back and 1" and $3\frac{1}{2}$ " up from the bottom. Blade clips are for grader blade (Ref 8) storage when not in use. Place notches on the top of the grader blade into slots on blade clips.
3. Turn machine on and test for proper operation.

42-178 INFIELD SCARIFIER WITH VERTICAL BLADES DRAWING

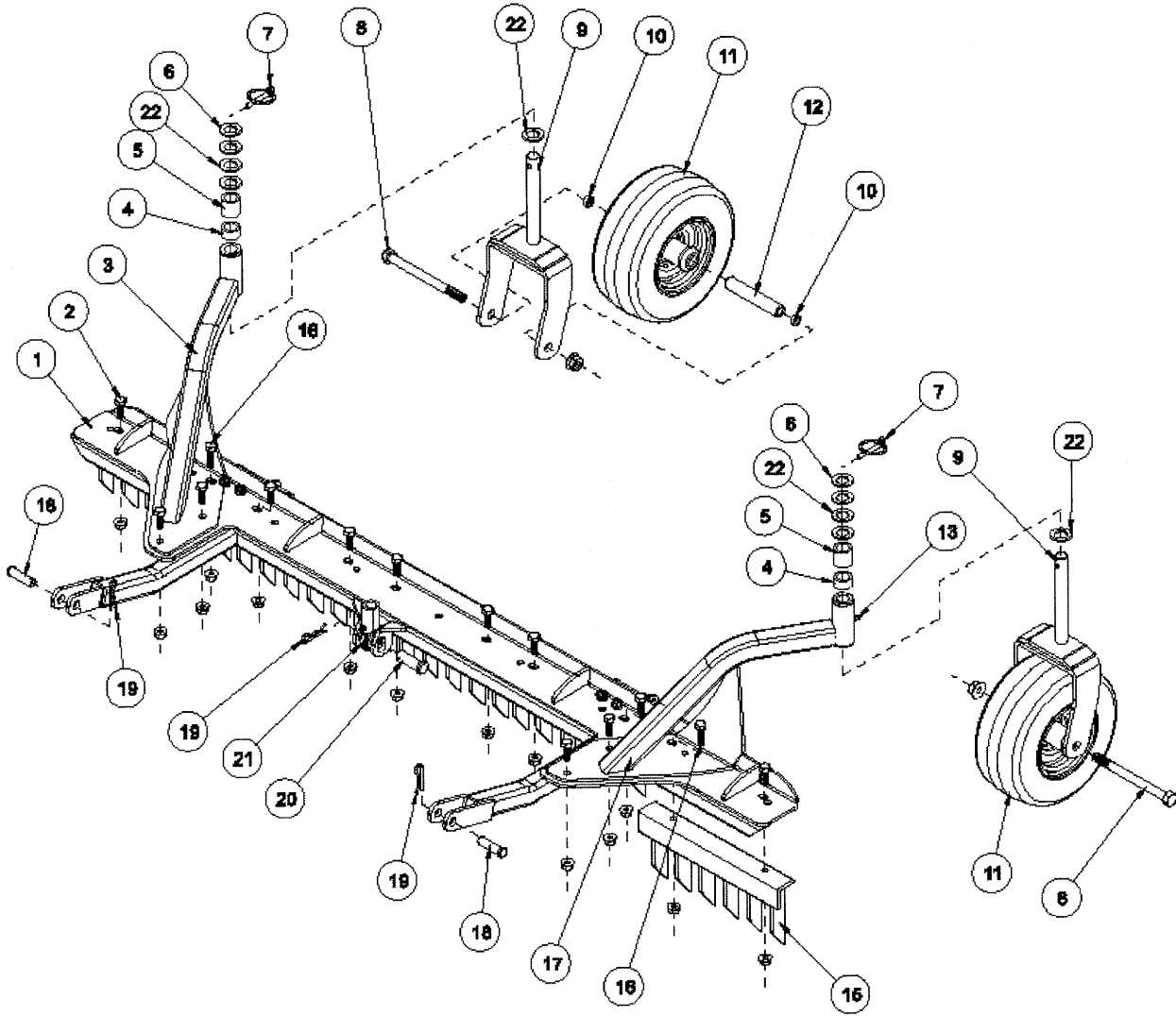

42-178 INFIELD SCARIFIER WITH VERTICAL BLADES PARTS LIST

REF#	PART#	DESCRIPTION	QUANTITY
1	42-203	Attachment Lift Assembly	1
2	HB-38-16-100	Bolt $\frac{3}{8}$ - 16 x 1	12
	HNTL-38-16	Lock Nut $\frac{3}{8}$ - 16	12
3	42-205	Left Castor Wheel Bracket	1
	10-025	Bushing (part of 42-205)	2
4	42-215	Short Spacer	2
5	42-214	Long Spacer	2
6	HMB-34-14	Machine Bushing $\frac{3}{4}$ x 14GA	2
7	42-539	Lynch Pin $\frac{5}{16}$	2
8	HB-12-13-600	Bolt $\frac{1}{2}$ -13 x 6	2
	HNTL-12-13	Lock Nut $\frac{1}{2}$ - 13	2
9	42-204	Castor Fork	2
10	42-212	Castor Wheel Spacer	4
11	42-202	Tire and Wheel	2
	42-202-01	Tire 9 x 3.5 x 4 Ply	2
	42-202-02	Wheel	2
	42-202-03	Cap	2
	42-202-04	Bearing	2
	42-202-05	Seal	2
12	42-213	Axle Bearing	2
13	HG-14-28-180	Grease Fitting $\frac{1}{4}$ - 28 x 180° (part of 42-205 and 42-206)	2
15	26-042	Tine Segment	5
16	HB-38-16-125	Bolt $\frac{3}{8}$ - 16 x $1\frac{1}{4}$	2
	HNTL-38-16	Lock Nut $\frac{3}{8}$ - 16	2
17	42-206	Right Castor Wheel Bracket	1
	10-025	Bushing (part of 42-205)	2
18	HCP-12-200	Clevis Pin $\frac{1}{2}$ x 2	2
19	HHP-18	Bridge Pin $\frac{1}{8}$	3
20	HCP-58-250	Clevis Pin $\frac{5}{8}$ x $2\frac{1}{2}$	1
21	18-154	Rod End (part of machine)	1
22	HMB-34-10	Machine Bushing $\frac{3}{4}$ x 10GA	8

42-178 SCARIFIER MOUNTING DRAWING

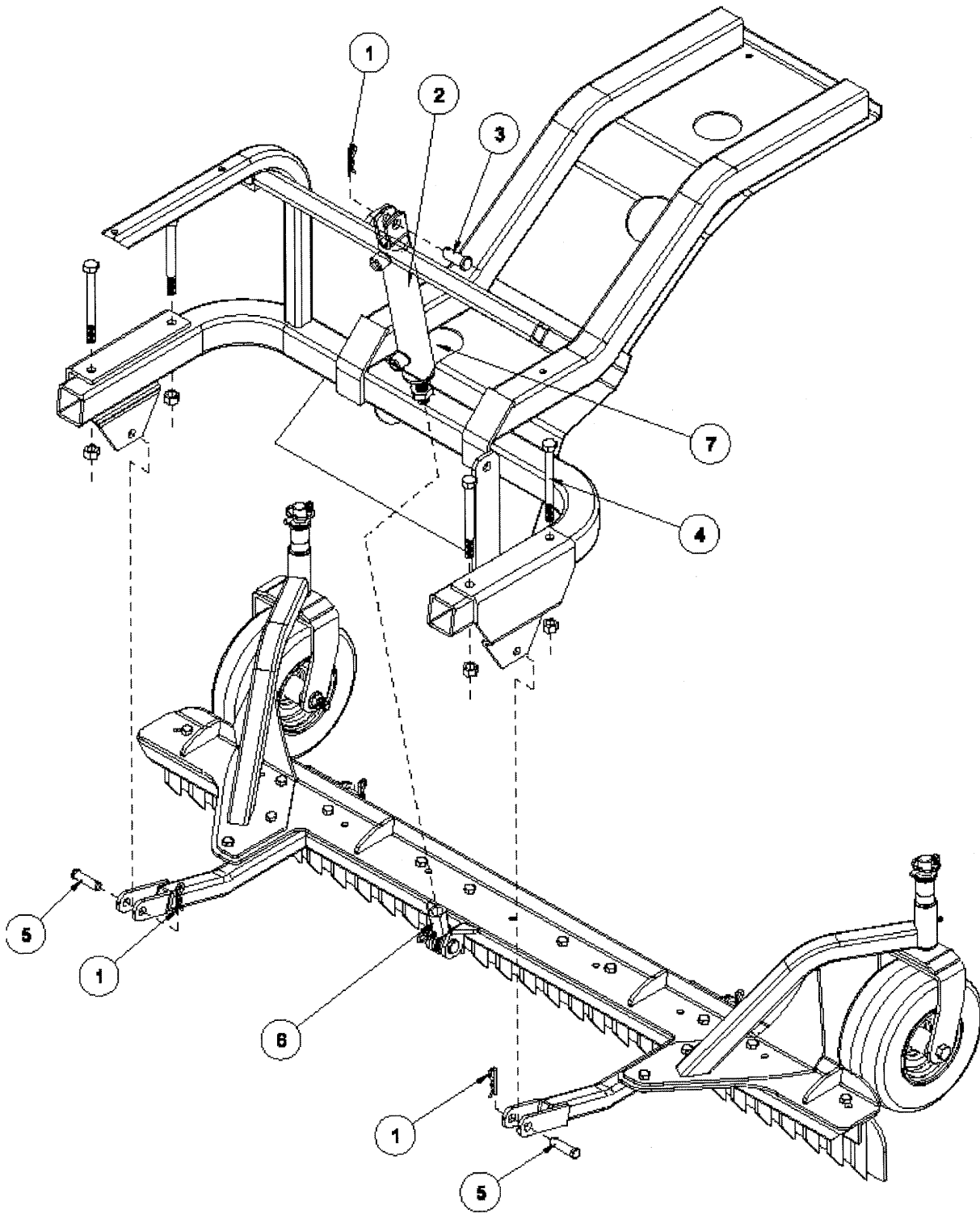

42-178 SCARIFER MOUNTING PARTS LIST

REF#	PART#	DESCRIPTION	QUANTITY
1	HHP-18	Bridge Pin $\frac{1}{8}$	3
2	10-135	Hydraulic Cylinder (part of machine)	1
3	HCP-58-175	Clevis Pin $\frac{5}{8} \times 1\frac{3}{4}$	1
4	HB-12-13-500	Bolt $\frac{1}{2}$ - 13 x 5	4
	HNTL-12-13	Lock Nut $\frac{1}{2}$ - 13	4
5	HCP-12-200	Clevis Pin $\frac{1}{2}$ - 2	2
6	18-154	Rod End (part of machine)	1
7	42-217	Cylinder Mount (part of machine)	1

INSTALLATION INSTRUCTIONS

1. Assemble the Scarifier as shown on previous page.
2. Remove the rod end (Ref 6) on the hydraulic cylinder (Ref 2) from the cylinder mount (Ref 7). Remove the cylinder mount (Ref 7) from the machine.
- *3. Place the handle and linkage onto the empty linkage port of the two bank valve on the machine.
4. Slide the Scarifier under the machine lining up the hydraulic cylinder and the center of the attachment lift assembly.
5. Extend hydraulic cylinder all the way down by pushing the lever forward.
6. Mount the rod end of the cylinder onto the attachment lift assembly and secure with a clevis pin and bridge pin.
7. Attach the arms on the attachment lift to the attachment mount on the machine and secure with clevis pin and bridge pin.
8. Turn machine on and test for proper operation.
9. Adjust castor wheels by placing the short or long spacer on the castor wheel fork before placing the castor wheel assembly into the castor wheel brackets. Be sure both castor wheels are adjusted to the same height.

* For machines prior to serial numbers 4500 (3WD) and 12500 (2WD).

42-179 INFIELD SCARIFIER WITH CHISEL BLADES DRAWING

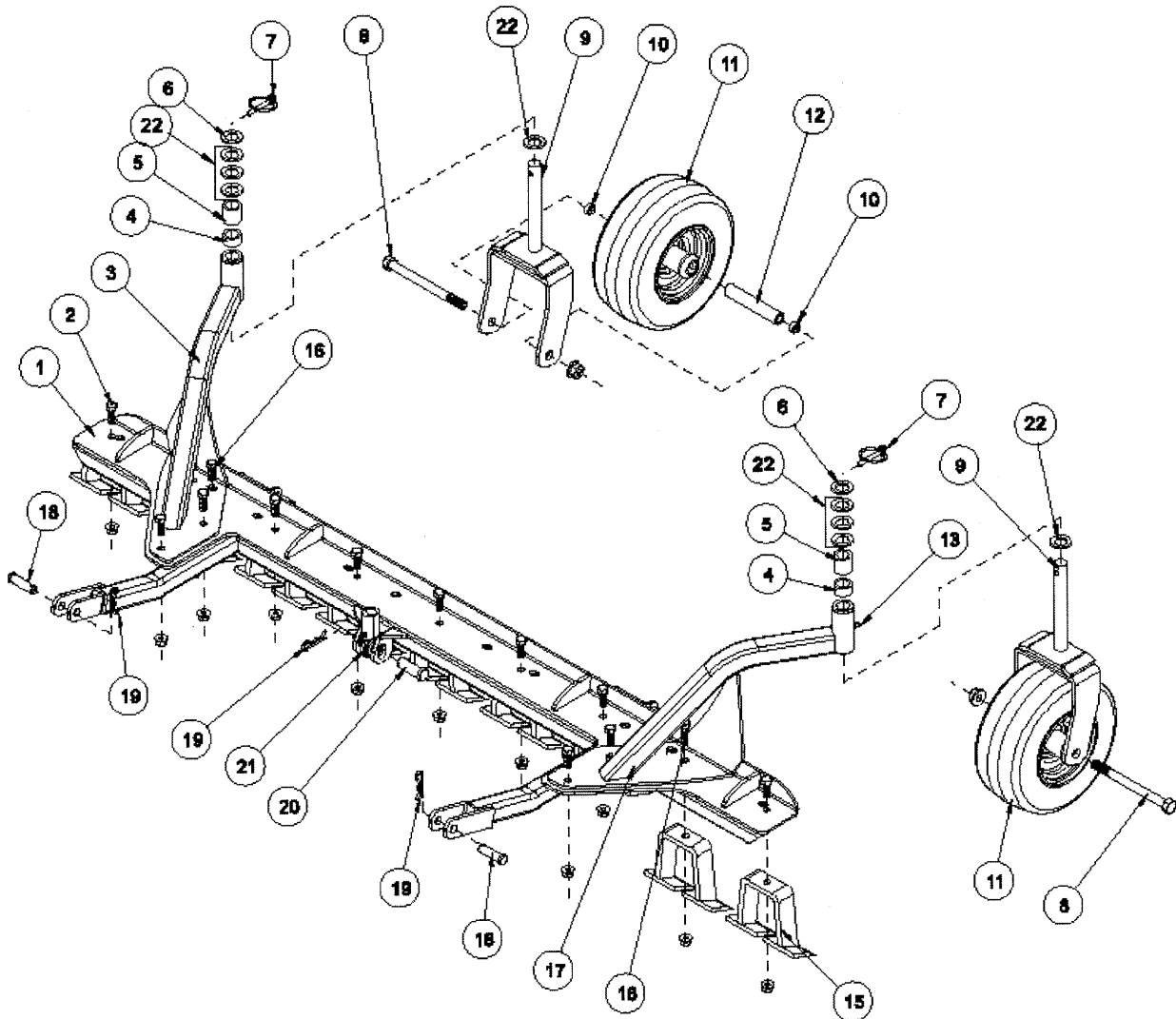

42-179 INFIELD SCARIFIER WITH CHISEL BLADES PARTS LIST

REF#	PART#	DESCRIPTION	QUANTITY
1	42-203	Attachment Lift Assembly	1
2	HB-38-16-125	Bolt $\frac{3}{8}$ - 16 x 1 $\frac{1}{4}$	11
	HNTL-38-16	Lock Nut $\frac{3}{8}$ - 16	11
3	42-205	Left Castor Wheel Bracket	1
	10-025	Bushing (part of 42-205)	2
4	42-215	Short Spacer	2
5	42-214	Long Spacer	2
6	HMB-34-14	Machine Bushing $\frac{3}{4}$ x 14GA	2
7	42-539	Lynch Pin $\frac{5}{16}$	2
8	HB-12-13-600	Bolt $\frac{1}{2}$ -13 x 6	2
	HNTL-12-13	Lock Nut $\frac{1}{2}$ - 13	2
9	42-204	Castor Fork	2
10	42-212	Castor Wheel Spacer	4
11	42-202	Tire and Wheel	2
	42-202-01	Tire 9 x 3.5 x 4 Ply	2
	42-202-02	Wheel	2
	42-202-03	Cap	2
	42-202-04	Bearing	2
	42-202-05	Seal	2
12	42-213	Axle Bearing	2
13	HG-14-28-180	Grease Fitting $\frac{1}{4}$ - 28 x 180° (part of 42-205 and 42-206)	2
15	13-114	Digger Blade	9
16	HB-38-16-150	Bolt $\frac{3}{8}$ - 16 x 1 $\frac{1}{2}$	2
	HNTL-38-16	Lock Nut $\frac{3}{8}$ - 16	2
17	42-206	Right Castor Wheel Bracket	1
	10-025	Bushing (part of 42-205)	2
18	HCP-12-200	Clevis Pin $\frac{1}{2}$ x 2	2
19	HHP-18	Bridge Pin $\frac{1}{8}$	3
20	HCP-58-250	Clevis Pin $\frac{5}{8}$ x 2 $\frac{1}{2}$	1
21	18-154	Rod End (part of machine)	1
22	HMB-34-10	Machine Bushing $\frac{3}{4}$ x 10GA	8

42-179 SCARIFIER MOUNTING DRAWING

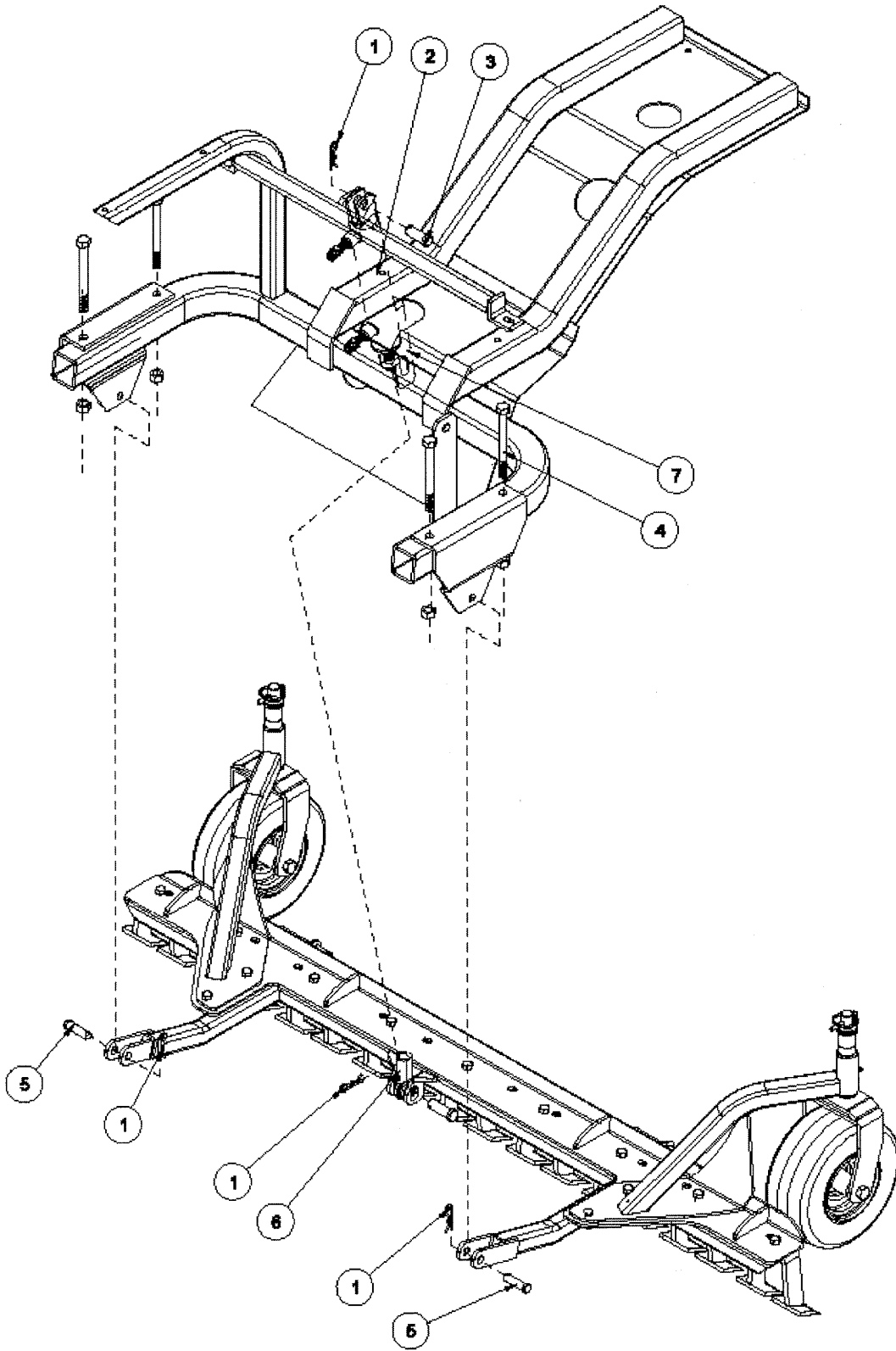

42-179 SCARIFER MOUNTING PARTS LIST

REF#	PART#	DESCRIPTION	QUANTITY
1	HHP-18	Bridge Pin $\frac{1}{8}$	3
2	10-135	Hydraulic Cylinder (part of machine)	1
3	HCP-58-175	Clevis Pin $\frac{5}{8} \times 1\frac{3}{4}$	1
4	HB-12-13-500	Bolt $\frac{1}{2}$ - 13 x 5	4
	HNTL-12-13	Lock Nut $\frac{1}{2}$ - 13	4
5	HCP-12-200	Clevis Pin $\frac{1}{2}$ - 2	2
6	18-154	Rod End (part of machine)	1
7	42-217	Cylinder Mount (part of machine)	1

INSTALLATION INSTRUCTIONS

1. Assemble the Scarifier as shown on previous page.
2. Remove the rod end (Ref 6) on the hydraulic cylinder (Ref 2) from the cylinder mount (Ref 7). Remove the cylinder mount (Ref 7) from the machine.
- *3. Place the handle and linkage onto the empty linkage port of the two bank valve on the machine.
4. Slide the Scarifier under the machine lining up the hydraulic cylinder and the center of the attachment lift assembly.
5. Extend hydraulic cylinder all the way down by pushing the lever forward.
6. Mount the rod end of the cylinder onto the attachment lift assembly and secure with a clevis pin and bridge pin.
7. Attach the arms on the attachment lift to the attachment mount on the machine and secure with clevis pin and bridge pin.
8. Turn machine on and test for proper operation.
9. Adjust castor wheels by placing the short or long spacer on the castor wheel fork before placing the castor wheel assembly into the castor wheel brackets. Be sure both castor wheels are adjusted to the same height.

* For machines prior to serial numbers 4500 (3WD) and 12500 (2WD).

42-285 SCARIFER WITH VERTICAL BLADES

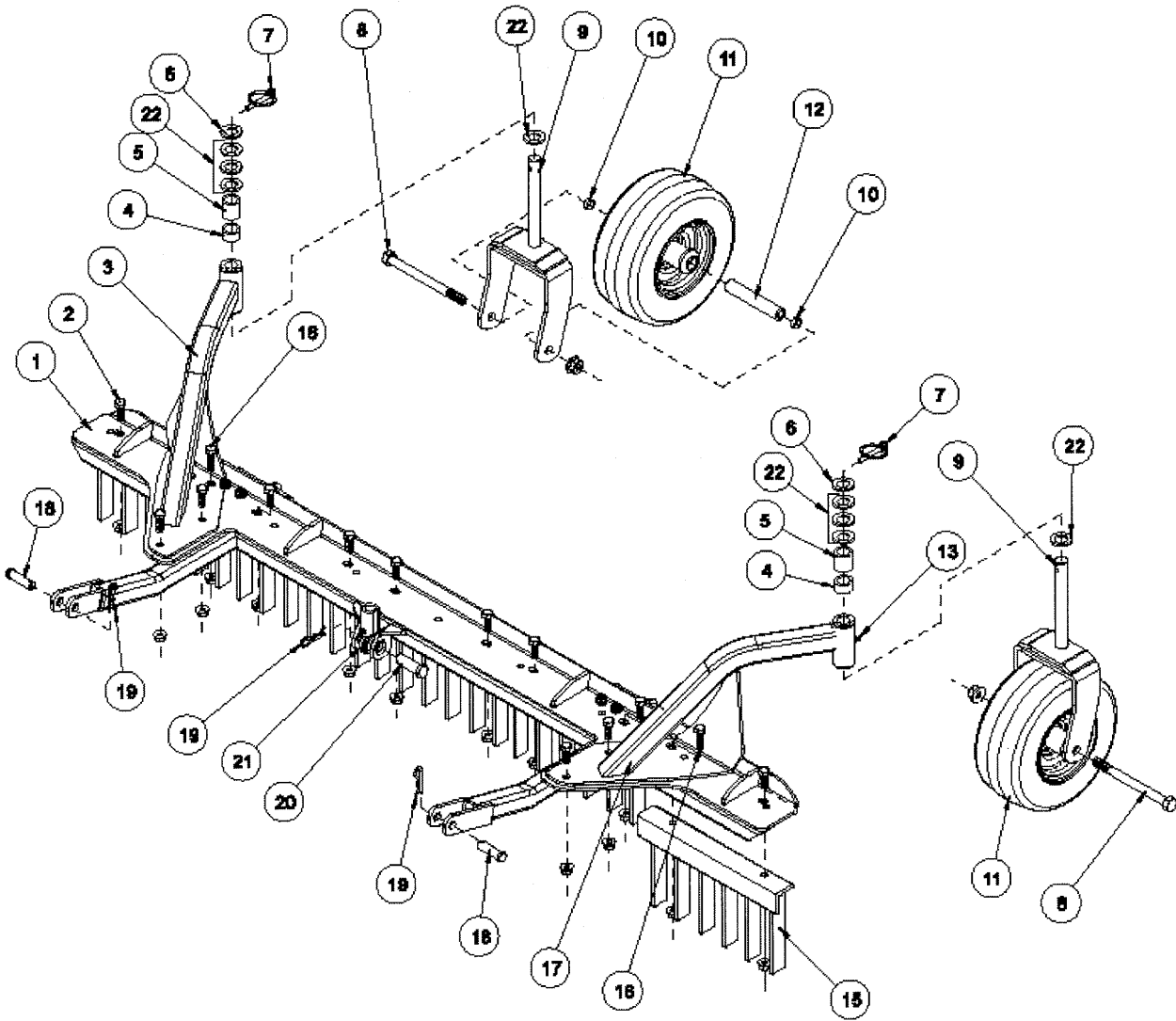

42-285 SCARIFIER WITH VERTICAL BLADES PARTS LIST

REF#	PART#	DESCRIPTION	QUANTITY
1	42-203	Attachment Lift Assembly	1
2	HB-38-16-100	Bolt $\frac{3}{8}$ - 16 x 1	12
	HNTL-38-16	Lock Nut $\frac{3}{8}$ - 16	12
3	42-288	Left Castor Wheel Bracket	1
	10-025	Bushing (part of 42-288)	2
4	42-215	Short Spacer	2
5	42-214	Long Spacer	2
6	HMB-34-14	Machine Bushing $\frac{3}{4}$ x 14GA	2
7	42-539	Lynch Pin $\frac{5}{16}$	2
8	HB-12-13-600	Bolt $\frac{1}{2}$ -13 x 6	2
	HNTL-12-13	Lock Nut $\frac{1}{2}$ - 13	2
9	42-204	Castor Fork	2
10	42-212	Castor Wheel Spacer	4
11	42-202	Tire and Wheel	2
	42-202-01	Tire 9 x 3.5 x 4 Ply	2
	42-202-02	Wheel	2
	42-202-03	Cap	4
	42-202-04	Bearing	4
	42-202-05	Seal	4
12	42-213	Axle Bearing	2
13	HG-14-28-180	Grease Fitting $\frac{1}{4}$ - 28 x 180° (part of 42-288 and 42-289)	2
15	42-241	Tine Segment	5
16	HB-38-16-125	Bolt $\frac{3}{8}$ - 16 x 1 $\frac{1}{4}$	2
	HNTL-38-16	Lock Nut $\frac{3}{8}$ - 16	2
17	42-289	Right Castor Wheel Bracket	1
	10-025	Bushing (part of 42-289)	2
18	HCP-12-175	Clevis Pin $\frac{1}{2}$ x 1 $\frac{3}{4}$	2
19	HHP-18	Bridge Pin $\frac{1}{8}$	3
20	HCP-58-250	Clevis Pin $\frac{5}{8}$ x 2 $\frac{1}{2}$	1
21	18-154	Rod End (part of machine)	1
22	HMB-34-10	Machine Bushing $\frac{3}{4}$ x 10GA	8

42-285 SCARIFER WITH VERTICAL BLADES MOUNTING DRAWING

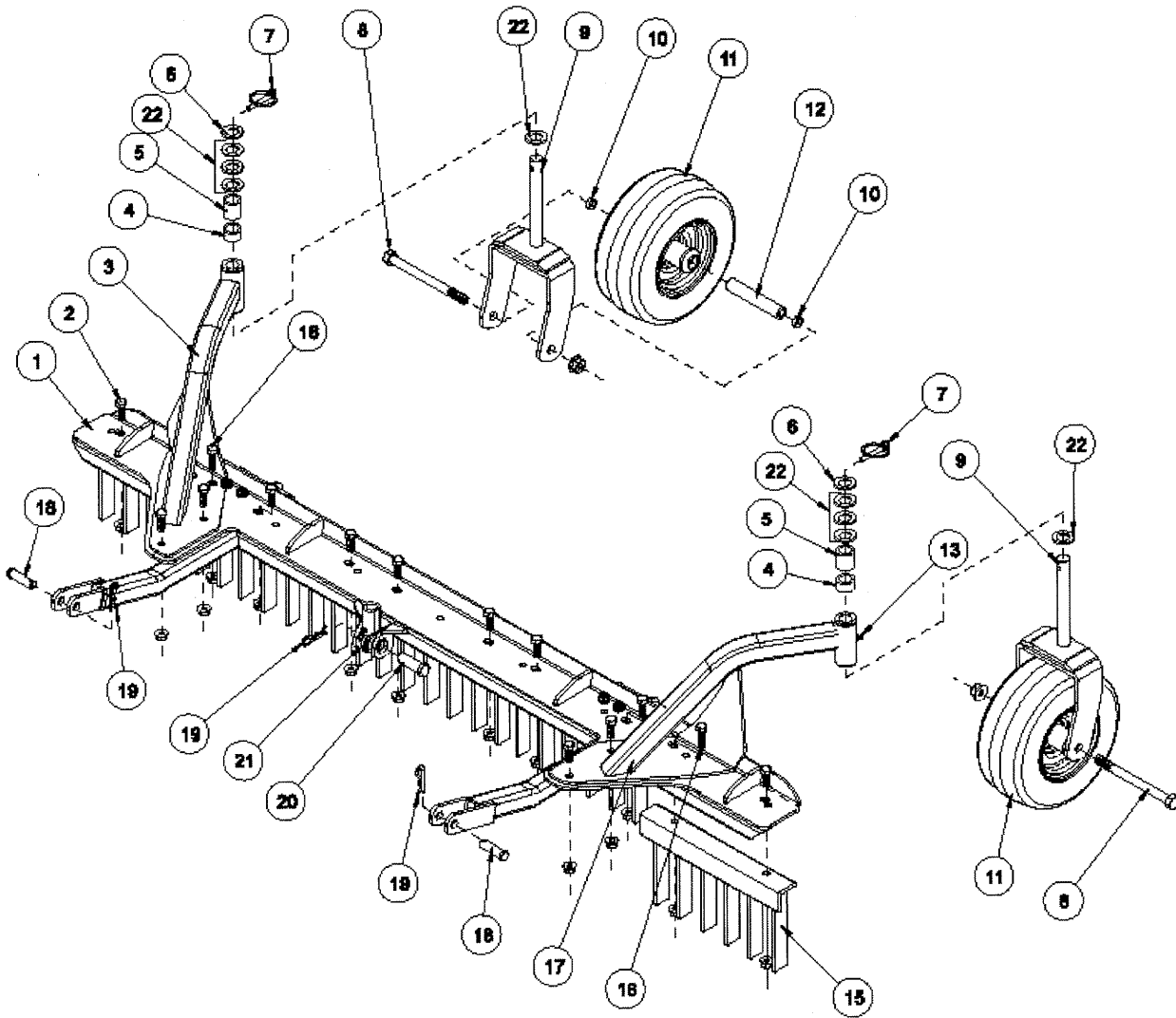

42-285 SCARIFIER WITH VERTICAL BLADES MOUNTING PARTS LIST

REF#	PART#	DESCRIPTION	QUANTITY
1	HHP-18	Bridge Pin $\frac{1}{8}$	3
2		Hydraulic Cylinder (part of machine)	1
3	HCP-58-175	Clevis Pin $\frac{5}{8} \times 1\frac{3}{4}$	1
4	HB-12-13-500	Bolt $\frac{1}{2}$ - 13 x 5 (part of machine)	4
	HNTL-12-13	Lock Nut $\frac{1}{2}$ - 13 (part of machine)	4
5	HCP-12-175	Clevis Pin $\frac{1}{2}$ - $1\frac{3}{4}$	2
6	18-154	Rod End (part of machine)	1
7	42-217	Cylinder Mount (temporary part of machine)	1

INSTALLATION INSTRUCTIONS

1. Assemble the Scarifier as shown on previous page.
2. Disconnect the rod end (Ref 6) on the hydraulic cylinder (Ref 2) from the cylinder mount (Ref 7). Remove the cylinder mount (Ref 7) from the machine.
3. Place the handle and linkage onto the empty linkage port of the two bank valve on the machine.
4. Slide the Scarifier under the machine lining up the hydraulic cylinder and the center of the attachment lift assembly.
5. Extend hydraulic cylinder all the way down by pushing the lever forward.
6. Mount the rod end of the cylinder onto the attachment lift assembly and secure with a clevis pin and bridge pin.
7. Attach the arms on the attachment lift to the attachment mount on the machine and secure with clevis pin and bridge pin.
8. Turn machine on and test for proper operation.
9. Adjust castor wheels by placing the short or long spacer on the castor wheel fork before placing the castor wheel assembly into the castor wheel brackets. Be sure both castor wheels are adjusted to the same height.

42-026 84" (213CM) STAINLESS STEEL TOURNAMENT RAKE DRAWING

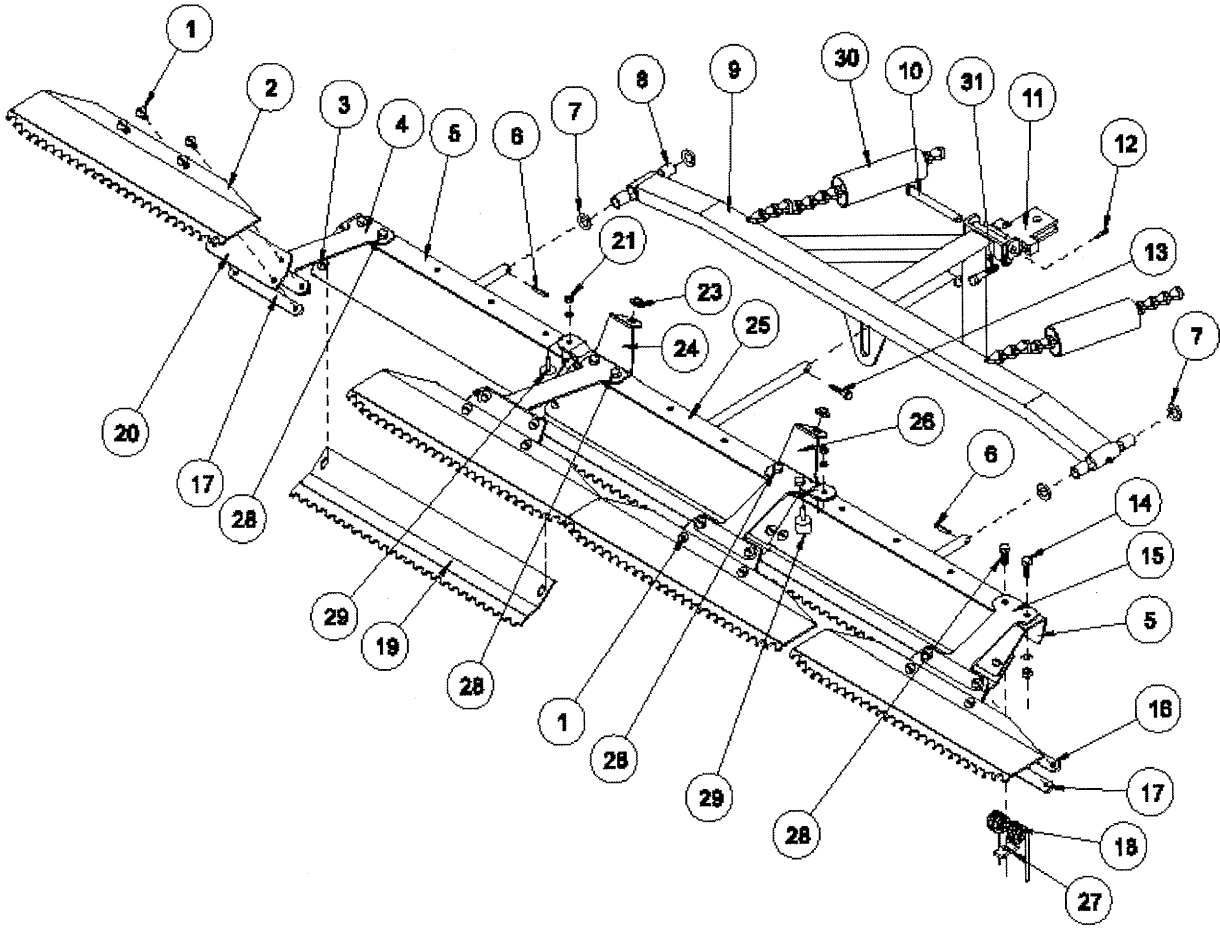

42-026 84" (213CM) STAINLESS STEEL TOURNAMENT RAKE PARTS LIST

REF#	PART#	DESCRIPTION	QUANTITY
1	HSTS-516-18-100	Stainless Truss Head Screw $\frac{5}{16}$ - 18 x 1	16
	HWL-516	Lockwasher $\frac{5}{16}$	16
	HN-516-18	Nut $\frac{5}{16}$ - 18	16
2	42-104	Finishing Blades	4
3	HSTS-516-18-100	Stainless Truss Head Screw $\frac{5}{16}$ - 18 x 1	6
	HW-516	Washer $\frac{5}{16}$	6
	HWL-516	Lockwasher $\frac{5}{16}$	6
	HN-516-18	Nut $\frac{5}{16}$ - 18	6
4	42-111	Left Outside Mount	1
5	42-102	Outside Rake	2
6	HRP-14-100	Roll Pin $\frac{1}{4}$ x 1	2
7	HMB-58-14	Machine Bushing $\frac{5}{8}$ x 14GA	4
8	20-018	Oillite Bushing (comes with drawbar)	4
9	42-100	Draw Bar	1
	25-338	Decal, Speed Boss	1
10	HCP-12-450	Clevis Pin $\frac{1}{2}$ x $4\frac{1}{2}$	1
11	13-647	Hitch	1
	HCP-12-150	Clevis Pin $\frac{1}{2}$ x $1\frac{1}{2}$	1
	HHP-18	Bridge Pin $\frac{1}{8}$	1
12	HP-18-100	Cotter Pin $\frac{1}{8}$ x 1	1
13	HB-14-20-175	Bolt $\frac{1}{4}$ - 20 x $1\frac{3}{4}$	1
	HNTL-14-20	Lock Nut $\frac{1}{4}$ - 20	1
14	HSTPS-38-16-125	Stainless Steel Phillips Truss Head Screw $\frac{3}{8}$ - 16 x $1\frac{1}{4}$	4
	HWL-38	Lockwasher $\frac{3}{8}$	4
	HN-38-16	Nut $\frac{3}{8}$ - 16	4
15	42-109	Right Outside Mount	1
16	42-105	Top Strap	4
17	42-106	Bottom Strap	4
18	42-122	Rake Spring	12
19	42-103	Groomer Blades	3
20	42-107	Matting	4
21	HNC-14-20	Cap Nut $\frac{1}{4}$ - 20	2
	HWL-14	Lockwasher $\frac{1}{4}$	2
23	42-116	Rubber insert	2
24	42-110	Left Inside Mount	1
25	42-101	Center Rake	1
26	42-108	Right Inside Mount	1
27	42-177	Spring Holder	12
28	HSTPS-38-16-125	Stainless Steel Phillips Truss Head Screw $\frac{3}{8}$ - 16 x $1\frac{1}{4}$	12
	HWL-38	Lockwasher $\frac{3}{8}$	12
	HN-38-16	Nut $\frac{3}{8}$ - 16	12
29	15-013	Rubber Bumper	2
30	8892-6	Hose Wrap $\frac{1}{4}$ "	2
31	HSSQ-38-16-200	Square Head Set Screw $\frac{3}{8}$ - 16 x 2 (comes with 13-647)	2
	HN-38-16	Nut $\frac{3}{8}$ - 16 (comes with 13-647)	2

42-026 INSTALLATION INSTRUCTIONS

1. Attach drawbar (Ref 9) to hitch (Ref 11) using clevis pin (Ref 10) and cotter pin (Ref 12).
2. Attach rubber bumper (Ref 29) using cap nut and lock washer (Ref 21). Attach the rubber inserts (Ref 23) to the inside mounts (Ref 24 and 26).
3. Attach the left outside mount (Ref 4), the left inside mount (Ref 24), the outside trowel mount (Ref 15), and the inside trowel mount (Ref 26) to the outside and center rakes (Ref 5 and 25) as shown. Use the 1 $\frac{1}{4}$ " stainless steel truss head screws (Ref 14) on the outside hole of each rake.
4. Use the spring holder (Ref 27) and the 1 $\frac{1}{4}$ " stainless steel truss head screws (Ref 28) to attach rake springs (Ref 18) to the rakes.
5. Slide a machine bushing onto outside rake frames then slide the outside rake frames (Ref 5) into the tubing on the end of the drawbar. Hold in place with another machine bushing and a roll pin (Ref 6).
6. Attach center rake (Ref 25) to draw bar (Ref 9) as shown, using the $\frac{1}{4}$ - 20 - 1 $\frac{3}{4}$ bolt and lock nut (Ref 13) with the shaft of the center rake between the tabs on the bottom of the drawbar.
7. Attach the matting (Ref 20) and the top strap (Ref 16) to the inside and outside mounts using stainless steel truss head screw $\frac{5}{16}$ - 18 x 1 (Ref 1). Attach four finishing blades (Ref 2) to the matting on the inside and outside mounts with the stainless steel truss head screw $\frac{5}{16}$ - 18 x 1 (Ref 1) going through the finishing blade, matting, and bottom strap (Ref 17).
8. Place the three groomer blades (Ref 19) under the three rake assemblies as shown, using (Ref 3).
9. Attach the rake hitch (Ref 11) to the trap rake hitch.
10. The end links of chain on the drawbar are to be hooked to the hooks of the trap rake lift.
11. With the rake on the ground pull the rake to the right side until it is 2-3 inches from the tire.
12. Using the adjustment screw (Ref 31) on the right side of hitch, adjust the screw until it hits the trap rake hitch, located on rear axle. Lock nut so adjustment will not change.
13. Repeat steps 8 and 9 on left side.
14. Turn machine on and test for operation of rake assembly by raising and lowering the rake assembly. Also with rake down, turn sharp corners to check that rake does not touch wheels.

NOTE: Test rake in sand to assure tire tracks are covered by the rake when turning sharp corners in either direction. If there are tire tracks, readjust using the adjusting screws on the hitch, so the rake comes closer to the tire.

42-128 72" (183CM) STAINLESS STEEL TOURNAMENT RAKE DRAWING

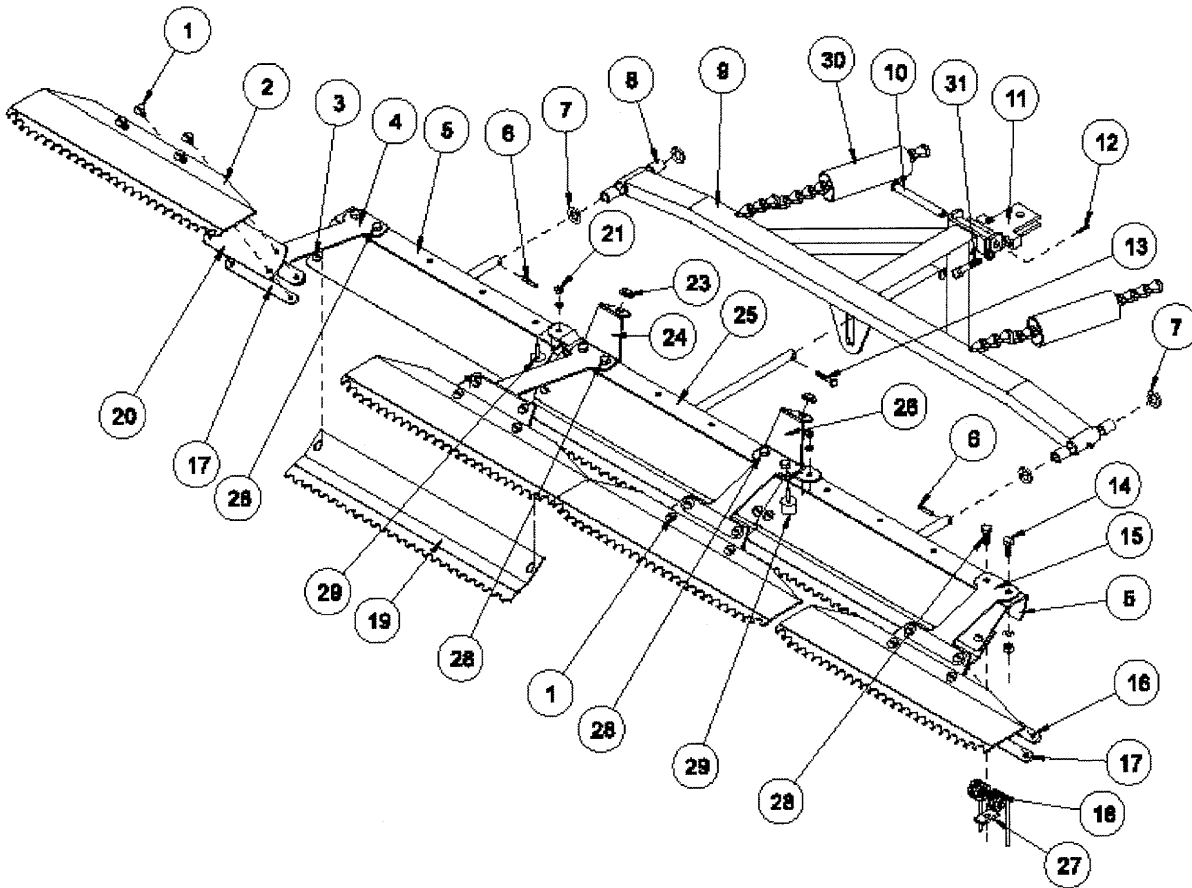

42-128 72" (183 CM) STAINLESS STEEL TOURNAMENT RAKE PARTS LIST

REF#	PART#	DESCRIPTION	QUANTITY
1	HSTS-516-18-100	Stainless Steel Truss Head Screw ⁵ / ₁₆ - 18 x 1	16
	HWL-516	Lock Washer ⁵ / ₁₆	16
	HN-516-18	Nut ⁵ / ₁₆ - 18	16
2	42-137	Finishing Blades	4
3	HSTS-516-18-100	Stainless Steel Truss Head Screw ⁵ / ₁₆ - 18 x 1	6
	HW-516	Washer ⁵ / ₁₆	6
	HWL-516	Lock Washer ⁵ / ₁₆	6
	HN-516-18	Nut ⁵ / ₁₆ - 18	6
4	42-111	Left Outside Mount	1
5	42-140	Outside Rake	2
6	HRP-14-100	Roll Pin 1/4 x 1	2
7	HMB-58-14	Machine Bushing ⁵ / ₈ x 14GA	4
8	20-018	Oilite Bushing (comes with 42-141)	4
9	42-141	Draw Bar	1
10	HCP-12-450	Clevis Pin 1/2 x 4 1/2	1
11	13-647	Hitch	1
	HCP-12-150	Clevis Pin 1/2 x 1 1/2	1
	HHP-18	Bridge Pin 1/8	1
12	HP-18-100	Cotter Pin 1/8 x 1	1
13	HB-14-20-175	Bolt 1/4 - 20 x 1 3/4	1
	HNTL-14-20	Lock Nut 1/4 - 20	1
14	HSTPS-38-16-125	Stainless Steel Phillips Truss Head Screw ³ / ₈ - 16 x 1 1/4	4
	HWL-38	Lock Washer ³ / ₈	4
	HN-38-16	Nut ³ / ₈ - 16	4
15	42-109	Outside Trowel Mount	1
16	42-105	Top Strap	4
17	42-106	Bottom Strap	4
18	42-122	Rake Spring	12
19	42-138	Groomer Blades	3
20	42-107	Matting	4
21	HNC-14-20	Cap Nut 1/4 - 20	2
	HWL-14	Lock Washer 1/4	2
23	42-116	Rubber Insert	2
24	42-110	Left Inside Mount	1
25	42-139	Center Rake	1
26	42-108	Inside Trowel Mount	1
27	42-177	Spring Holder	12
28	HSTPS-38-16-125	Stainless Steel Phillips Truss Head Screw ³ / ₈ - 16 x 1 1/4	12
	HWL-38	Lock Washer ³ / ₈	12
	HN-38-16	Nut ³ / ₈ - 16	12
29	15-013	Rubber Bumper	2
30	8892-6	Hose Wrap	2
31	HSSQ-38-16-200	Square Head Set Screw ³ / ₈ - 16 x 2 (comes with 13-647)	2
	HN-38-16	Nut ³ / ₈ - 16 (comes with 13-647)	2

42-128 INSTALLATION INSTRUCTIONS

1. Attach drawbar (Ref 9) to hitch (Ref 11) using clevis pin (Ref 10) and cotter pin (Ref 12).
2. Attach rubber bumper (Ref 29) using cap nut and lock washer (Ref 21). Attach the rubber inserts (Ref 23) to the inside mounts (Ref 24 and 26).
3. Attach the left outside mount (Ref 4), the left inside mount (Ref 24), the outside trowel mount (Ref 15), and the inside trowel mount (Ref 26) to the outside and center rakes (Ref 5 and 25) as shown. Use the 1¹/₄" stainless steel truss head screws (Ref 14) on the outside hole of each rake.
4. Use the spring holder (Ref 27) and the 1¹/₄" stainless steel truss head screws (Ref 28) to attach rake springs (Ref 18) to the rakes.
5. Slide a machine bushing onto outside rake frames then slide the outside rake frames (Ref 5) into the tubing on the end of the drawbar. Hold in place with another machine bushing and a roll pin (Ref 6).
6. Attach center rake (Ref 25) to draw bar (Ref 9) as shown, using the 1/4 - 20 - 1³/₄ bolt and lock nut (Ref 13) with the shaft of the center rake between the tabs on the bottom of the drawbar.
7. Attach the matting (Ref 20) and the top strap (Ref 16) to the inside and outside mounts using stainless steel truss head screw ⁵/₁₆- 18 x 1 (Ref 1). Attach four finishing blades (Ref 2) to the matting on the inside and outside mounts with the stainless steel truss head screw ⁵/₁₆- 18 x 1 (Ref 1) going through the finishing blade, matting, and bottom strap (Ref 17).
8. Place the three groomer blades (Ref 19) under the three rake assemblies as shown, using (Ref 3).
9. Attach the rake hitch (Ref 11) to the trap rake hitch.
10. The end links of chain on the drawbar are to be hooked to the hooks of the trap rake lift.
11. With the rake on the ground pull the rake to the right side until it is 2-3 inches from the tire.
12. Using the adjustment screw (Ref 31) on the right side of hitch, adjust the screw until it hits the trap rake hitch, located on rear axle. Lock nut so adjustment will not change.
13. Repeat steps 8 and 9 on left side.
14. Turn machine on and test for operation of rake assembly by raising and lowering the rake assembly. Also with rake down, turn sharp corners to check that rake does not touch wheels.

NOTE: Test rake in sand to assure tire tracks are covered by the rake when turning sharp corners in either direction. If there are tire tracks, readjust using the adjusting screws on the hitch, so the rake comes closer to the tire.

13-438 RAKE ASSEMBLY WITH FINISHING BLADES DRAWING

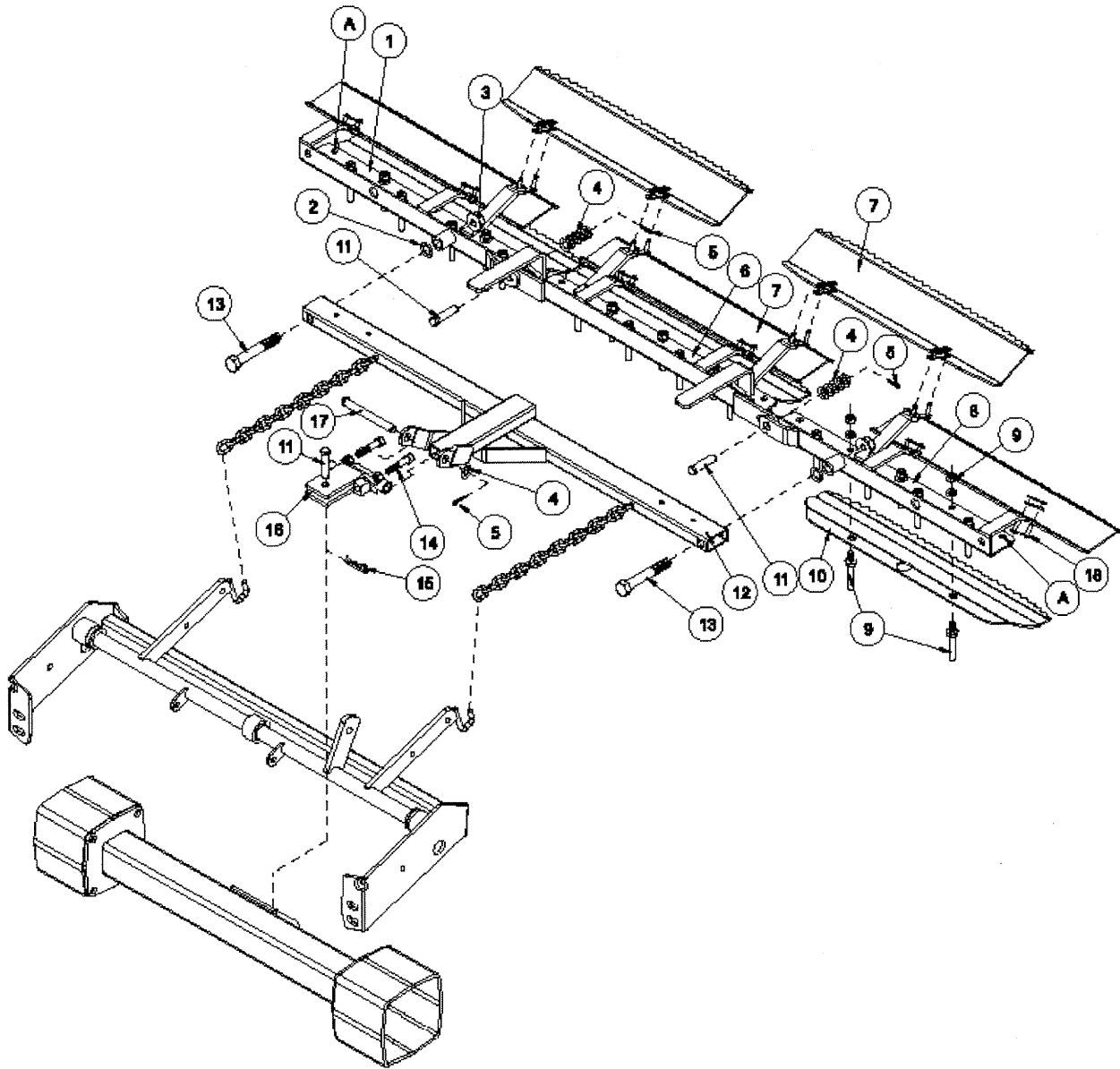

13-438 RAKE ASSEMBLY WITH FINISHING BLADES PARTS LIST

REF#	PART#	DESCRIPTION	QUANTITY
1	13-441	Right Rake	1
2	HMB-58-14	Machine Bushing $\frac{5}{8}$ x 14GA	2
3	HNCL-58-11	Lock Nut $\frac{5}{8}$ - 11	2
4	HMB-12-14	Machine Bushing $\frac{1}{2}$ x 14GA	11
5	HP-18-100	Cotter Pin $\frac{1}{8}$ x 1	3
6	13-440	Center Rake	1
7	13-443	Finishing Blade	5
8	13-439	Left Rake	1
9*	19-106	Rake teeth	25
10	13-442	Groomer Blade	3
11	HCP-12-150	Clevis Pin $\frac{1}{2}$ - $1\frac{1}{2}$	3
12	13-365	Drawbar	1
13	HB-58-11-400	Bolt $\frac{5}{8}$ - 11 x 4	2
14	HSSQS-38-16-200	SS Square Head Set Screw $\frac{3}{8}$ - 16 x 2 (comes with 13-647)	2
	HN-38-16	Nut $\frac{3}{8}$ - 16 (comes with 13-647)	2
15	HHP-18	Bridge Pin $\frac{1}{8}$	1
16	13-647	Hitch (includes Ref 14)	1
17	HCP-12-450	Clevis Pin $\frac{1}{2}$ - $4\frac{1}{2}$	1
18	13-417	Connector Link	10
*	13-445	Rake Teeth Kit (25 Studs and Hardware)	1

INSTALLATION INSTRUCTIONS

1. Attach drawbar (Ref 12) to hitch (Ref 16) using clevis pin, machine bushing and cotter pin (Ref 17, 4 and 5).
2. Bolt rake teeth (Ref 9) to frames, keeping all the same length. Leave the two outside holes on right and left rake open (Ref A).
3. Lay out rake frames (Ref 1, 6 and 8). Connect them using clevis pin, machine bushing and cotter pin (Ref 11, 4 and 5).
4. Attach drawbar to left and right frames using bolt, machine bushing, and nut (Ref 13, 2 and 3).
5. Attach five finishing blades (Ref 7) to the tabs of the rake frames using master link (Ref 18). Blades may be mounted with saw tooth up or down, depending on the desired finish of the sand trap.
6. Attach the rake hitch (Ref 16) to trap rake hitch on the rear axle using a clevis pin and bridge pin (Ref 11 and 15).
7. The end links of chain on the drawbar are to be hooked to the hooks of the trap rake lift.
8. With the rake on the ground pull the rake to the right side until it is 2-3 inches from the tire.
9. Using the adjustment screw (Ref 14) on the right, adjust the screw until it hits the trap rake hitch, located on rear axle. Lock jam nut so adjustment will not change.
10. Repeat steps 8 and 9 on left side.
11. Turn machine on and test for operation of rake assembly by raising and lowering the rake assembly. Also with rake down, turn sharp corners to check that rake does not touch wheels.
12. **NOTE:** Test rake in sand to assure tire tracks are covered by the rake when turning sharp corners in either direction. If there are tire tracks, readjust using the adjusting screws on the hitch, so the rake comes closer to the tire.

GROOMER BLADES - GOLF COURSE USE ONLY.

1. Place the three groomer blades (Ref 10) under the three rake assemblies (Ref 1, 6 and 8).
2. Center blades below rear most row of rake teeth. The blade is designed to miss the outside two "teeth" and fit around the center "tooth".
3. Remove the two "teeth" that line up with slots of each groomer blade. Move blade up and into position and reattach "teeth". Blade thickness should be accounted for by shortening the "teeth" an equal length.

13-606 RAKE ASSEMBLY WITH LEXAN BLADES DRAWING

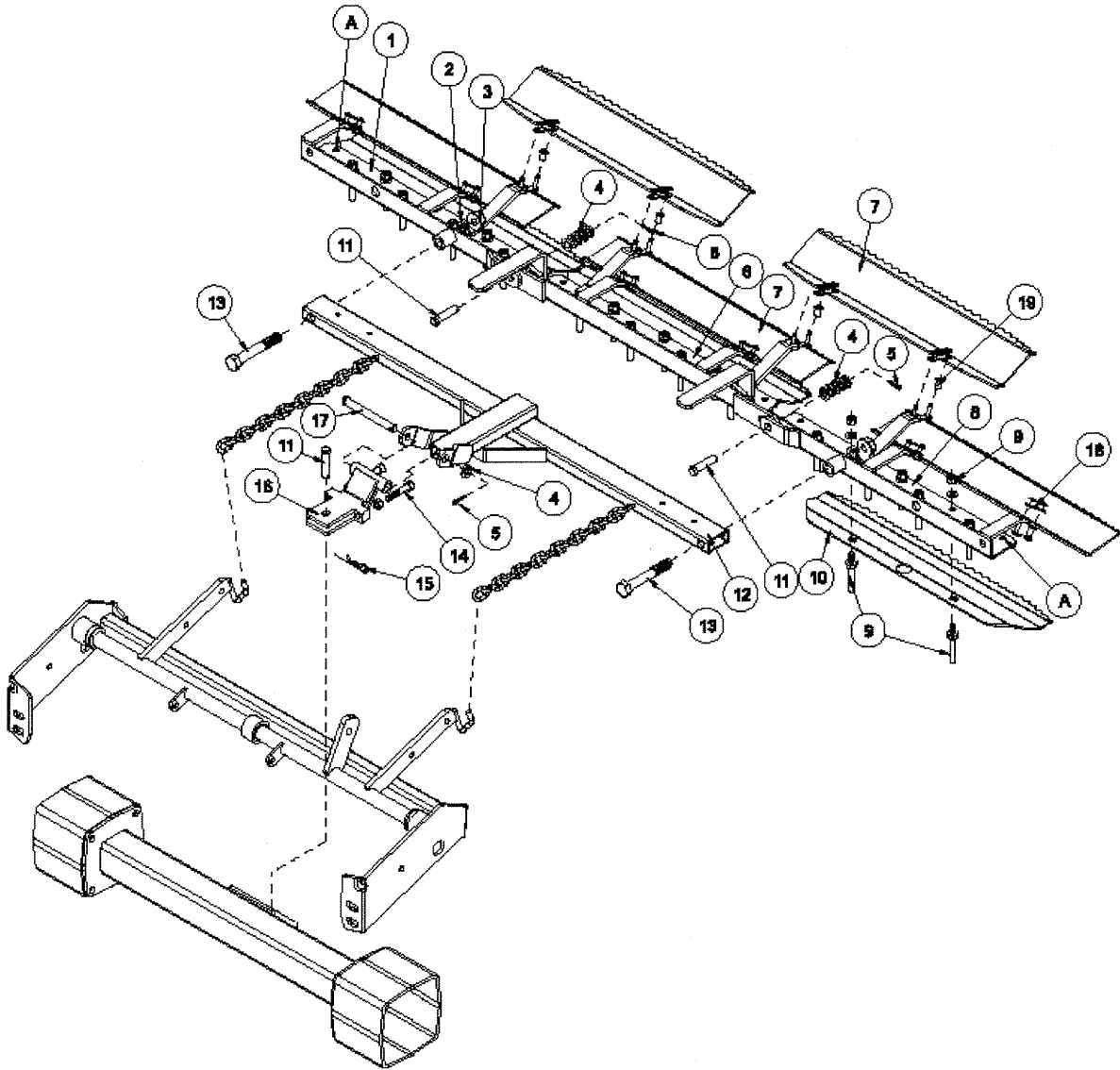

13-606 RAKE ASSEMBLY WITH LEXAN BLADES PARTS LIST

REF#	PART#	DESCRIPTION	QUANTITY
1	13-441	Right Rake	1
2	HMB-58-14	Machine Bushing $\frac{5}{8}$ x 14GA	2
3	HNCL-58-11	Lock Nut $\frac{5}{8}$ - 11	2
4	HMB-12-14	Machine Bushing $\frac{1}{2}$ x 14GA	11
5	HP-18-100	Cotter Pin $\frac{1}{8}$ x 1	3
6	13-440	Center Rake	1
7	13-805	Lexan Blade (with weight & rivets)	5
8	13-439	Left Rake	1
9*	19-106	Rake teeth	25
10	13-442	Groomer Blade	3
11	HCP-12-150	Clevis Pin $\frac{1}{2}$ - $1\frac{1}{2}$	3
12	13-365	Drawbar	1
13	HB-58-11-400	Bolt $\frac{5}{8}$ - 11 x 4	2
14	HSSQS-38-16-200	SS Square Head Set Screw $\frac{3}{8}$ -16 x 2 (comes with 13-647)	2
	HN-38-16	Nut $\frac{3}{8}$ - 16 (comes with 13-647)	2
15	HHP-18	Bridge Pin $\frac{1}{8}$	1
16	13-647	Hitch (includes Ref 14)	1
17	HCP-12-450	Clevis Pin $\frac{1}{2}$ - $4\frac{1}{2}$	1
18	13-417	Connector Link	10
19	18-272	Nylon Bushing	10
*	13-445	Rake Teeth Kit (25 Studs and Hardware)	1

INSTALLATION INSTRUCTIONS

1. Attach drawbar (Ref 12) to hitch (Ref 16) using clevis pin, machine bushing and cotter pin (Ref 17, 4 and 5).
2. Bolt rake teeth (Ref 9) to frames, keeping all the same length. Leave the two outside holes on right and left rake open (Ref A).
3. Lay out rake frames (Ref 1, 6 and 8). Connect them using clevis pin, machine bushing and cotter pin (Ref 11, 4 and 5).
4. Attach drawbar to left and right frames using bolt, machine bushing, and nut (Ref 13, 2 and 3).
5. Attach five lexan blades (Ref 7) to the tabs of the rake frames using master link (Ref 18) and nylon bushings (Ref 19). Blades may be mounted with saw tooth up or down, depending on the desired finish of the sand trap.
6. Attach the rake hitch (Ref 16) to trap rake hitch on the rear axle using a clevis pin and bridge pin (Ref 11 and 15).
7. The end links of chain on the drawbar are to be hooked to the hooks of the trap rake lift.
8. With the rake on the ground pull the rake to the right side until it is 2-3 inches from the tire.
9. Using the adjustment screw (Ref 14) on the right, adjust the screw until it hits the trap rake hitch, located on rear axle. Lock jam nut so adjustment will not change.
10. Repeat steps 8 and 9 on left side.
11. Turn machine on and test for operation of rake assembly by raising and lowering the rake assembly. Also with rake down, turn sharp corners to check that rake does not touch wheels.
12. **NOTE:** Test rake in sand to assure tire tracks are covered by the rake when turning sharp corners in either direction. If there are tire tracks, readjust using the adjusting screws on the hitch, so the rake comes closer to the tire.

GROOMER BLADES - GOLF COURSE USE ONLY.

1. Place the three groomer blades (Ref 10) under the three rake assemblies (Ref 1, 6 and 8).
2. Center blades below rear most row of rake teeth. The blade is designed to miss the outside two "teeth" and fit around the center "tooth".
3. Remove the two "teeth" that line up with slots of each groomer blade. Move blade up and into position and reattach "teeth". Blade thickness should be accounted for by shortening the "teeth" an equal length.

13-684 SAND RAKE BRUSH KIT DRAWING

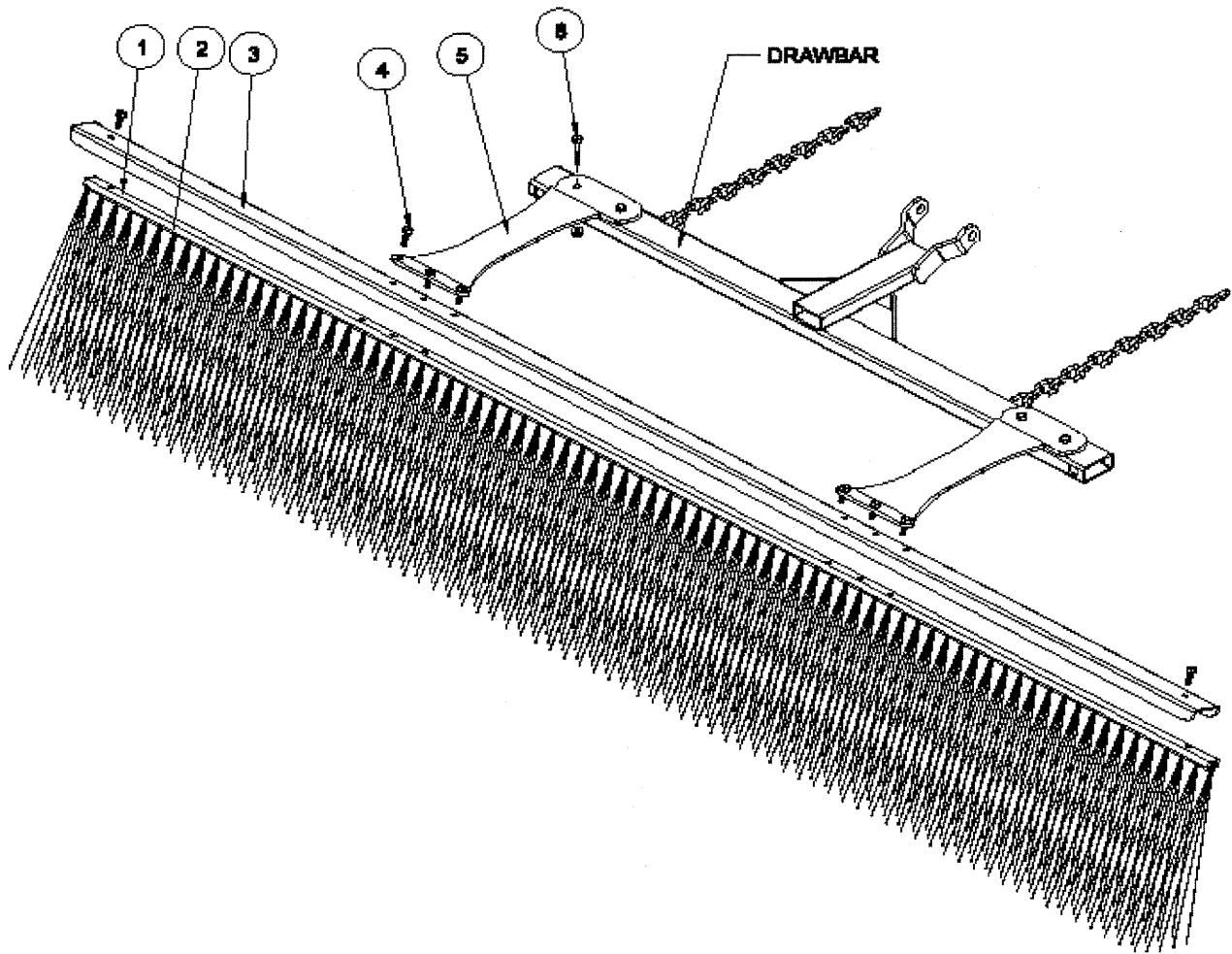

HOLE LOCATION

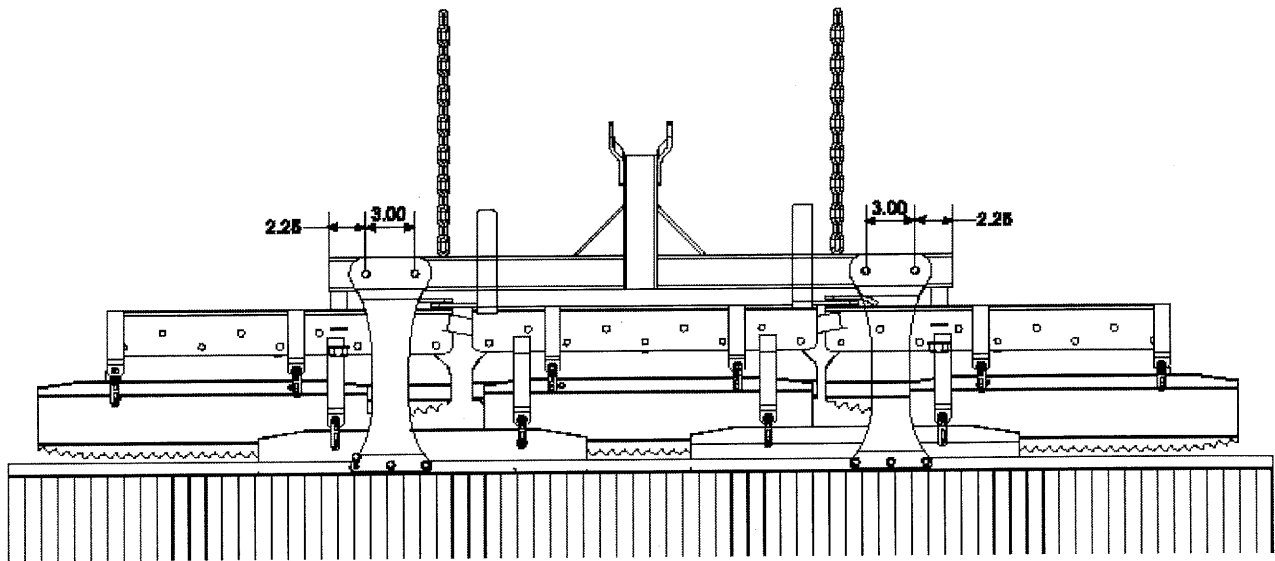

13-684 SAND RAKE BRUSH KIT PARTS LIST

REF#	PART#	DESCRIPTION	QUANTITY
1	13-683	Brush Track	1
2	13-682	Brush 77 x 11	1
3	13-688	Brush Channel	1
4	HB-14-20-075	Bolt $\frac{1}{4}$ - 20 x $\frac{3}{4}$	6
	HNFL-14-20	Flange Whiz-Lock Nut $\frac{1}{4}$ - 20	6
5	13-681	Mounting Brackets	2
6	HB-14-20-150	Bolt $\frac{1}{4}$ - 20 x $1\frac{1}{2}$	4
	HNFL-14-20	Flange Whiz-Lock Nuts $\frac{1}{4}$ - 20	4

INSTALLATION INSTRUCTIONS

1. Place the brush (Ref 2) into the brush track (Ref 1). Place the brush channel (Ref 3) between the brush track and the mounting brackets. Now bolt the mounting brackets (Ref 5) to the brush track using the $\frac{3}{4}$ " bolts and flange whiz-lock nuts (Ref 3).
2. Two holes need to be drilled into the drawbar of the rake to install the brush. Drill two .281 holes $2\frac{1}{4}$ " in from each end and 3" apart (see drawing).
3. Mount the brush assembly to the drawbar using four $\frac{3}{4}$ " bolts and flange whiz-lock nuts (Ref 5).

13-298 FAN RAKE ATTACHMENT DRAWING

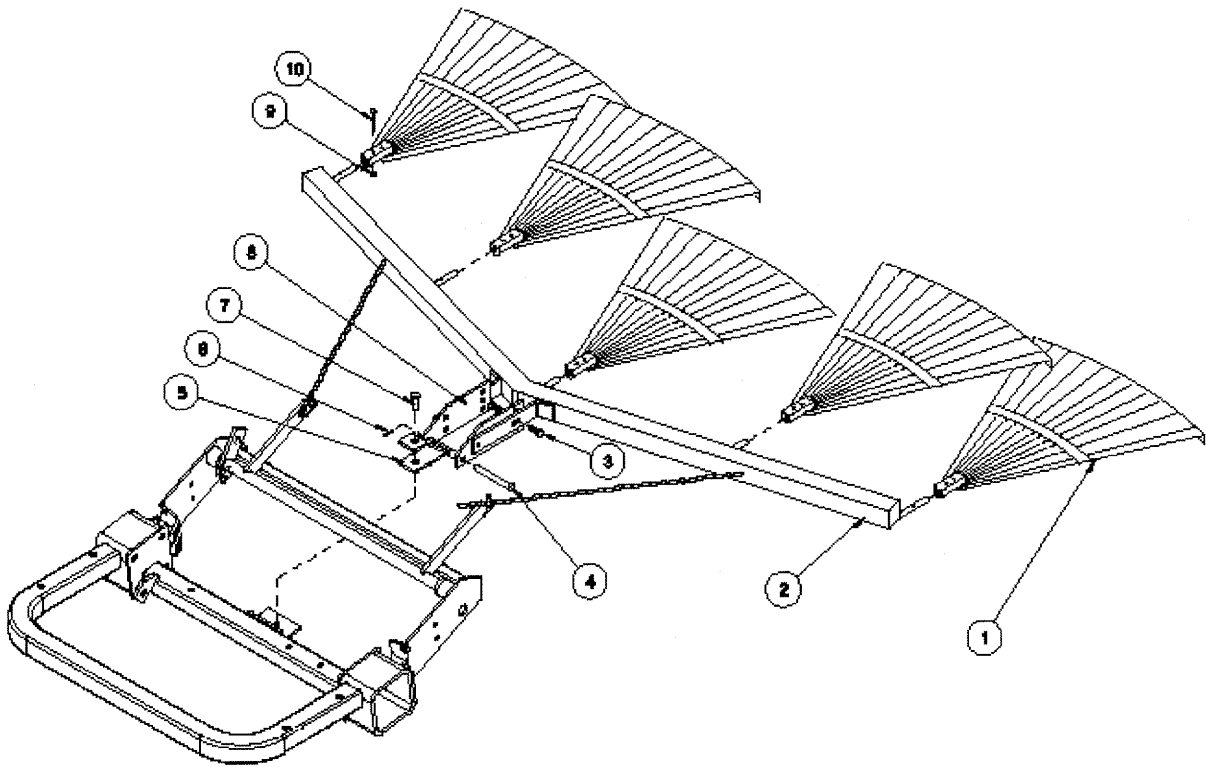

13-319 FAN RAKE KIT

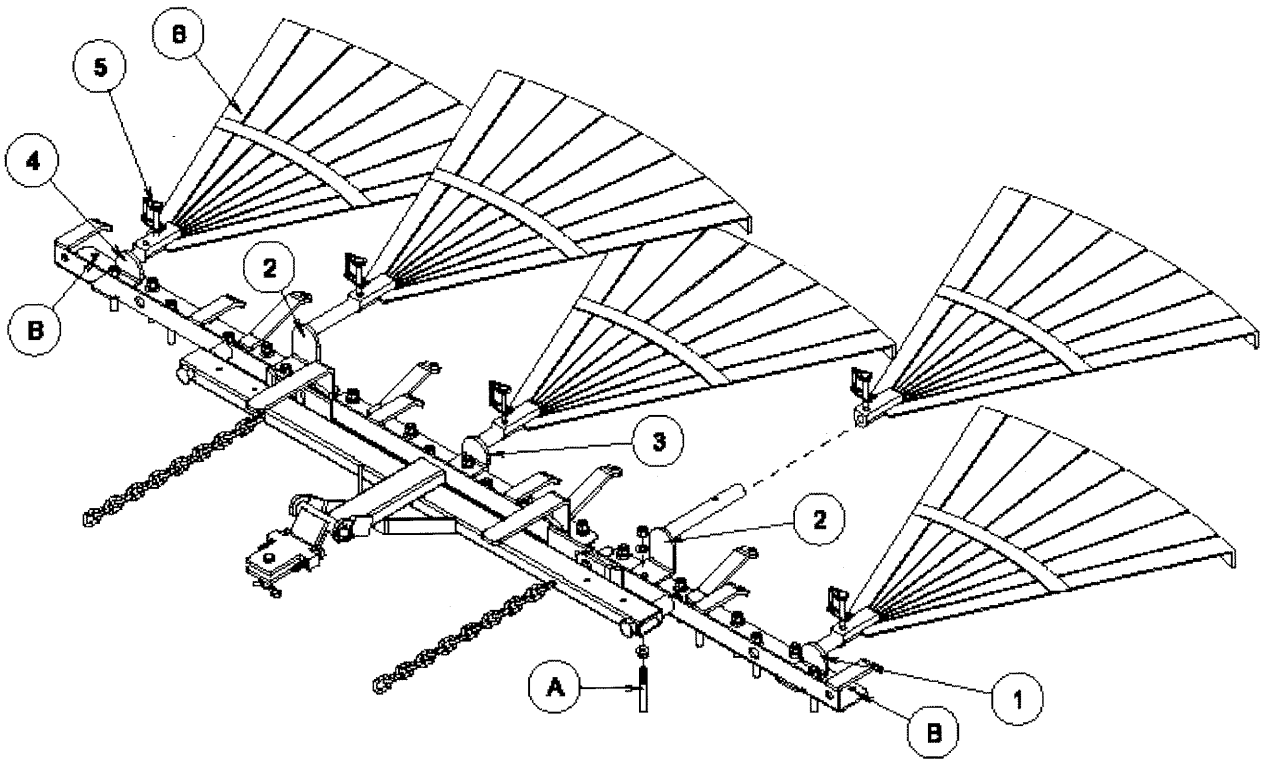

13-298 FAN RAKE ATTACHMENT PARTS LIST

REF#	PART#	DESCRIPTION	QUANTITY
1	13-310	Rake	5
2	13-306	Frame	1
3	HB-38-16-100	Bolt $\frac{3}{8}$ - 16 x 1	4
	HN-38-16	Nut $\frac{3}{8}$ - 16	4
	HWL-38	Lockwasher $\frac{3}{8}$	4
4	HCP-12-450	Clevis Pin $\frac{1}{2}$ x $4\frac{1}{2}$	1
5	19-107	Drawbar	1
6	HP-18-100	Cotter Pin $\frac{1}{8}$ x 1	1
7	HCP-12-150	Clevis Pin $\frac{1}{2}$ x $1\frac{1}{2}$	1
	HHP-18	Bridge Pin $\frac{1}{8}$	1
8	13-307	Hitch	2
9	HNCL-14-20	Center Lock Nut $\frac{1}{4}$ - 20	5
10	HB-14-20-200	Bolt $\frac{1}{4}$ - 20 x 2	5

INSTALLATION INSTRUCTIONS

1. Remove the complete rake assembly from the trap rake. Replace the clevis pin and bridge pin in the hitch for future use with the rake.
2. Assemble hitch (Ref 8) to frame (Ref 2) using hardware (Ref 3). Assemble drawbar (Ref 5) to the hitch using clevis pin (Ref 4) and cotter pin (Ref 6), as shown. The different holes in the hitch are for adjusting the angle of the rakes.
3. Assemble the five rakes (Ref 1) to the frame using the bolt and center lock nuts (Ref 9 and 10). Slide the fan rake assembly under the rear of the trap rake to the hitch. Attach the drawbar to the hitch using the clevis pin and the bridge pin (Ref 7).
4. Hook the chains from the frame to the hooks on the rake lift.

13-319 FAN RAKE PARTS LIST

REF#	PART#	DESCRIPTION	QUANTITY
1	13-326	Left Holder	1
2	13-329	Long Holder	2
3	13-327	Center Holder	1
4	13-328	Right Holder	1
5	29-541	Lock Pin	5
6	13-310	Rake	5

FAN RAKE KIT INSTRUCTIONS

1. Remove connector links that hold rake blades to rake frame if desired.
2. Remove groomer blades from rake frame that are held on with rake teeth studs (Ref A). Replace rake teeth studs, if desired.
3. Place left holder (Ref 1), angle side up, to the second rake tooth hole from the end and install rake tooth stud. The first rake tooth hole from each end (Ref B) have no rake teeth in them.
4. Remove the 8th rake tooth stud from the end of right and left rake frame and place long holders (Ref 2) on top, reinstall rake teeth studs.
5. Remove rake tooth in direct center of rake and install the center holder (Ref 3). Reinstall rake teeth studs.
6. Place right holder (Ref 4), angle side up, to the second rake tooth hole from the end and install rake tooth stud. The first rake tooth hole from each end (Ref B) have no rake teeth in them.
7. Slide fan rake (Ref 6) onto holders and pin with lock pin (Ref 5).

26-007 PROFESSIONAL INFIELD FINISHER DRAWING

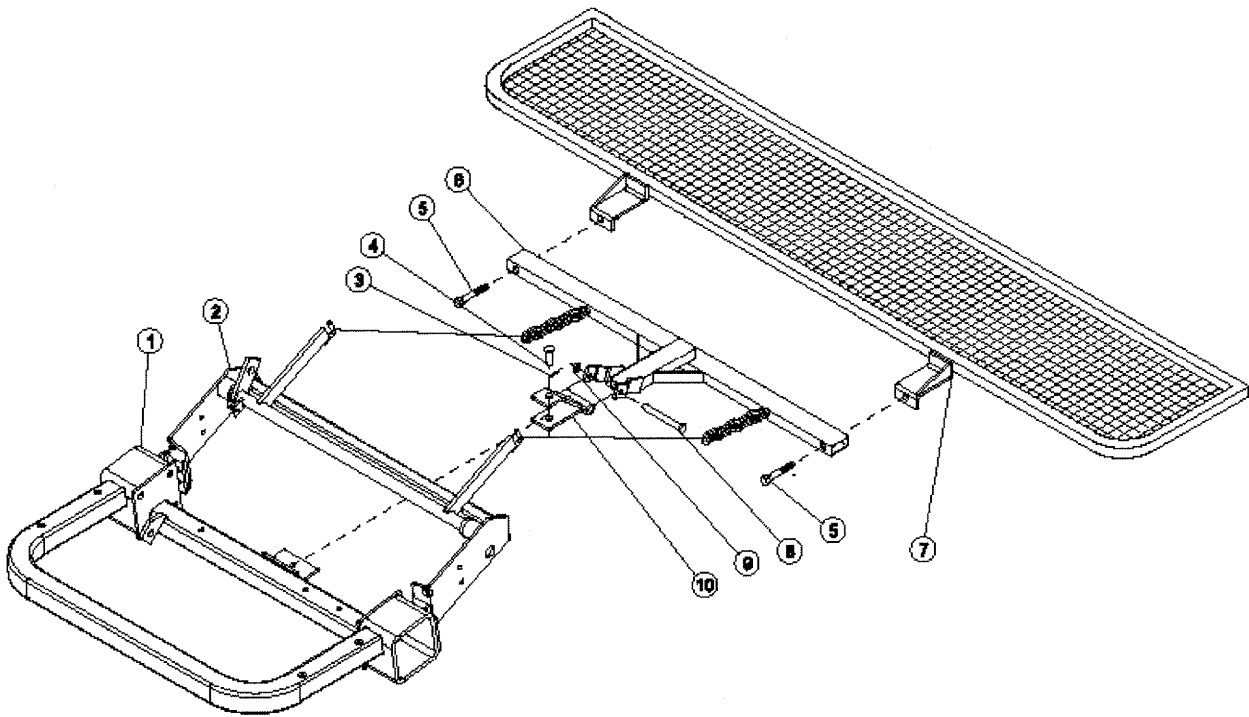

42-185 DRAG MAT KIT DRAWING

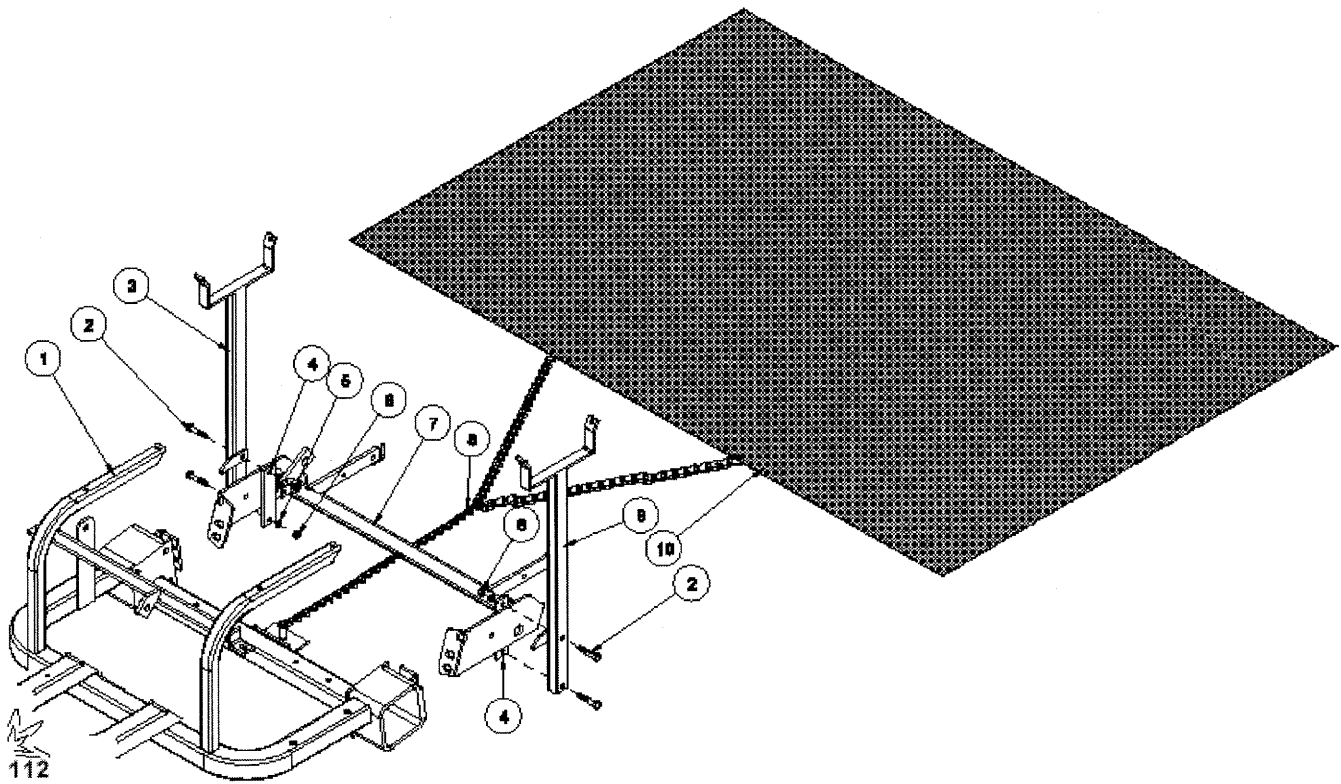

26-007 PROFESSIONAL INFIELD FINISHER PARTS LIST

REF#	PART#	DESCRIPTION	QUANTITY
1		Rear Axle (part of main frame)	1
2	42-024	Rake Lift	1
3	HP-18-100	Cotter Pin 1/8 x 1	1
4	HCP-12-150	Clevis Pin 1/2 x 1 1/2	1
5	HB-58-11-300	Bolt 5/8 - 11 x 3	2
	HNCL-58-11	Center Lock Nut 5/8 - 11	2
6	13-365	Drawbar	1
7	26-045	Leveling Screen	1
8	HCP-12-450	Clevis Pin 1/2 x 4 1/2	1
9	HMB-12-14	Machine Bushing 1/2 x 14GA	1
10	19-107	Hitch	1
11	HHP-18	Bridge Pin 1/8	1

INSTALLATION INSTRUCTIONS

The Professional Field Finisher is used for smoothing and leveling fields to professional standards.

1. Attach leveling screen (Ref 7) to drawbar (Ref 6) using two bolts (Ref 5) and center lock nuts.
2. Attach hitch (Ref 10) to drawbar (Ref 6) using clevis pin (Ref 8), machine bushing (Ref 9) and a cotter pin (Ref 3).
3. Mount Professional Field Finisher to the hitch on the trap rake with a clevis pin (Ref 4) and bridge pin (Ref 11).
4. Hook chains from finisher to rake lift arms.
5. **NOTE:** When assembled properly, rake will angle down from front to back. If front of finisher is not higher than the back, damage will result to infield.

42-185 DRAG MAT KIT PARTS LIST

REF#	PART#	DESCRIPTION	QUANTITY
1		Main Frame	1
2	HB-38-16-225	Bolt 3/8 - 16 x 2 1/4	4
3	42-186	Right Mat Carrier	1
4	13-157	Strap	2
5	HWL-38	Lock Washer 3/8	4
6	HN-38-16	Nut 3/8 - 16	4
7	42-024	Rake Lift (part of machine)	1
8	19-605	Drag Mat Chain	1
	HHP-18	Bridge Pin 1/8	1
9	42-187	Left Mat Carrier	1
10	19-601	Steel Mat	1

INSTALLATION INSTRUCTIONS

1. Looking from the rear of the Super Star, mount the mat carrier posts (Ref 3 & 9) outside the rear corner of the rake lift with the straps (Ref 4) on the inside of the rake lift side plate. Bolt into place with 3/8 - 16 x 2 1/4 bolts, lockwasher and nuts.
2. To carry the Drag Mat, roll it up and place it in the brackets of the mat carriers.
3. To use the Drag Mat, unroll the mat flat and hook it up to the Super Star hitch with the clevis pin in the chain and the bridge pin provided.

43-002 FLEX ACTION FIELD FINISHER WITH BRUSH DRAWING

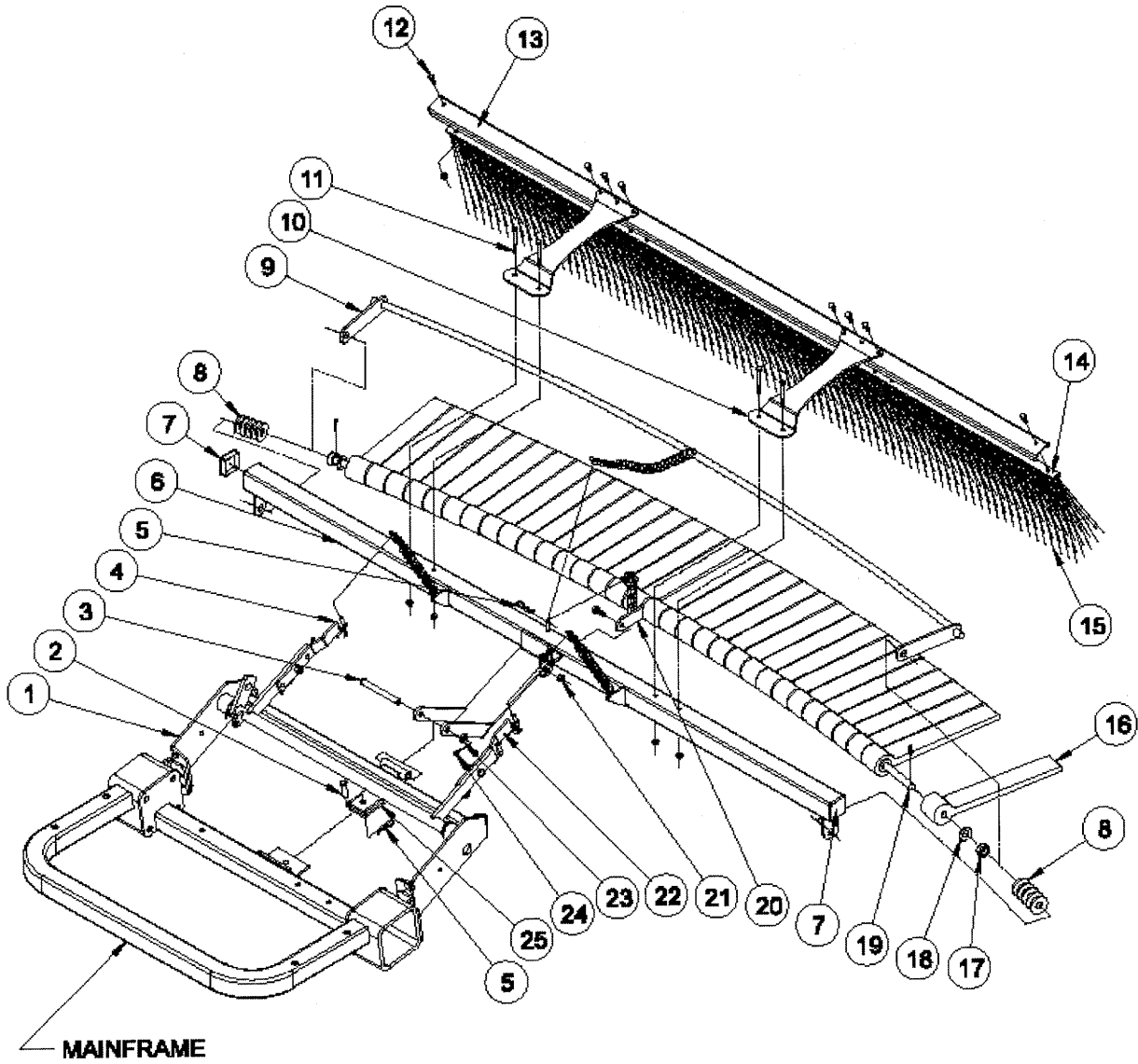

43-002 FLEX ACTION FIELD FINISHER WITH BRUSH PARTS LIST

REF#	PART#	DESCRIPTION	QUANTITY
1		Rake Lift (comes with machine)	1
2	HCP-12-150	Clevis Pin $1\frac{1}{2} \times 1\frac{1}{2}$	1
3	HCP-12-450	Clevis Pin, $1\frac{1}{2} \times 4\frac{1}{2}$	1
4	26-116	Right Extension Arm	1
	HB-38-16-125	Bolt $\frac{3}{8}$ - 16 x $1\frac{1}{4}$	1
	HNTL-38-16	Lock Nut $\frac{3}{8}$ - 16	1
5	HHP-18	Bridge Pin, $\frac{1}{8}$	2
6	26-046	Frame	1
7	18-297	Cap Plug	2
8	HMB-58-14	Machine Bushing $\frac{5}{8} \times 14$ GA	10
9	26-047	Leveler Bar	1
10	43-041	Mount Bracket	2
11	HB-14-20-250	Bolt, $\frac{1}{4}$ -20 x $2\frac{1}{2}$	4
	HNFL-14-20	Flange Whiz-Lock Nut, $\frac{1}{4}$ -20	4
12	HB-14-20-075	Bolt, $\frac{1}{4}$ -20 x $\frac{3}{4}$	8
	HNFL-14-20	Flange Whiz-Lock Nut, $\frac{1}{4}$ -20	8
13	13-688	Brush Channel	1
14	13-683	Brush Track	1
15	13-682	Brush, 77 x 11	1
16	26-041	Rasp Flail	32
17	11-040	Spacer, $\frac{3}{4}$ "	2
18	HW-58	Washer, $\frac{5}{8}$	32
19	26-049	Mounting Bar	1
	HP-18-100	Cotter Pin, $\frac{1}{8} \times 1$	2
20	26-048	Flail Bar Strap	1
21	HB-38-16-100	Bolt, $\frac{3}{8}$ - 16 x 1	1
	HNCL-38-16	Center Lock Nut, $\frac{3}{8}$ - 16	1
22	26-117	Left Extension Arm	1
	HB-38-16-125	Bolt $\frac{3}{8}$ - 16 x $1\frac{1}{4}$	1
	HNTL-38-16	Lock Nut $\frac{3}{8}$ - 16	1
23	HMB-12-14	Machine Bushing, $\frac{1}{2}$ - 14GA	1
24	HP-18-100	Cotter Pin, $\frac{1}{8} \times 1$	1
25	19-107	Draw Bar Assembly	1

RAKE LIFT ARM HOLE PLACEMENT

If the Lift Arms on the Rake Lift are not drilled, use the following dimensions to drill $\varnothing 13/32$ holes to mount the extension arms to.

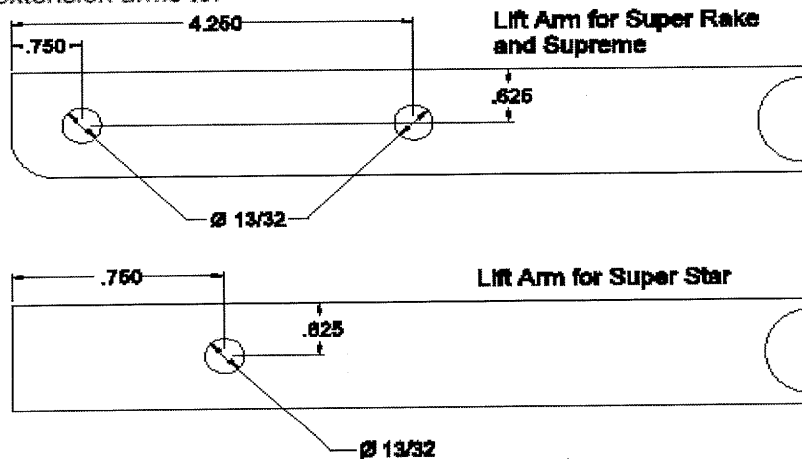

43-002 FLEX ACTION FIELD FINISHER WITH BRUSH DRAWING

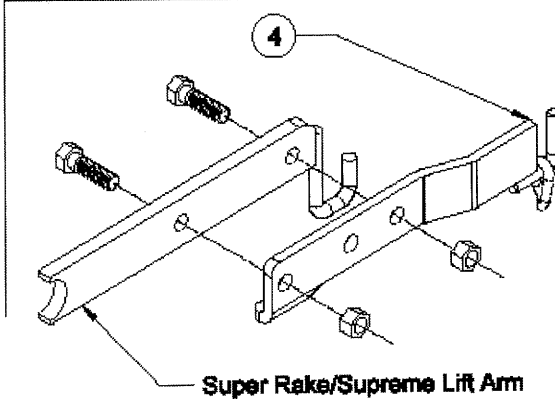
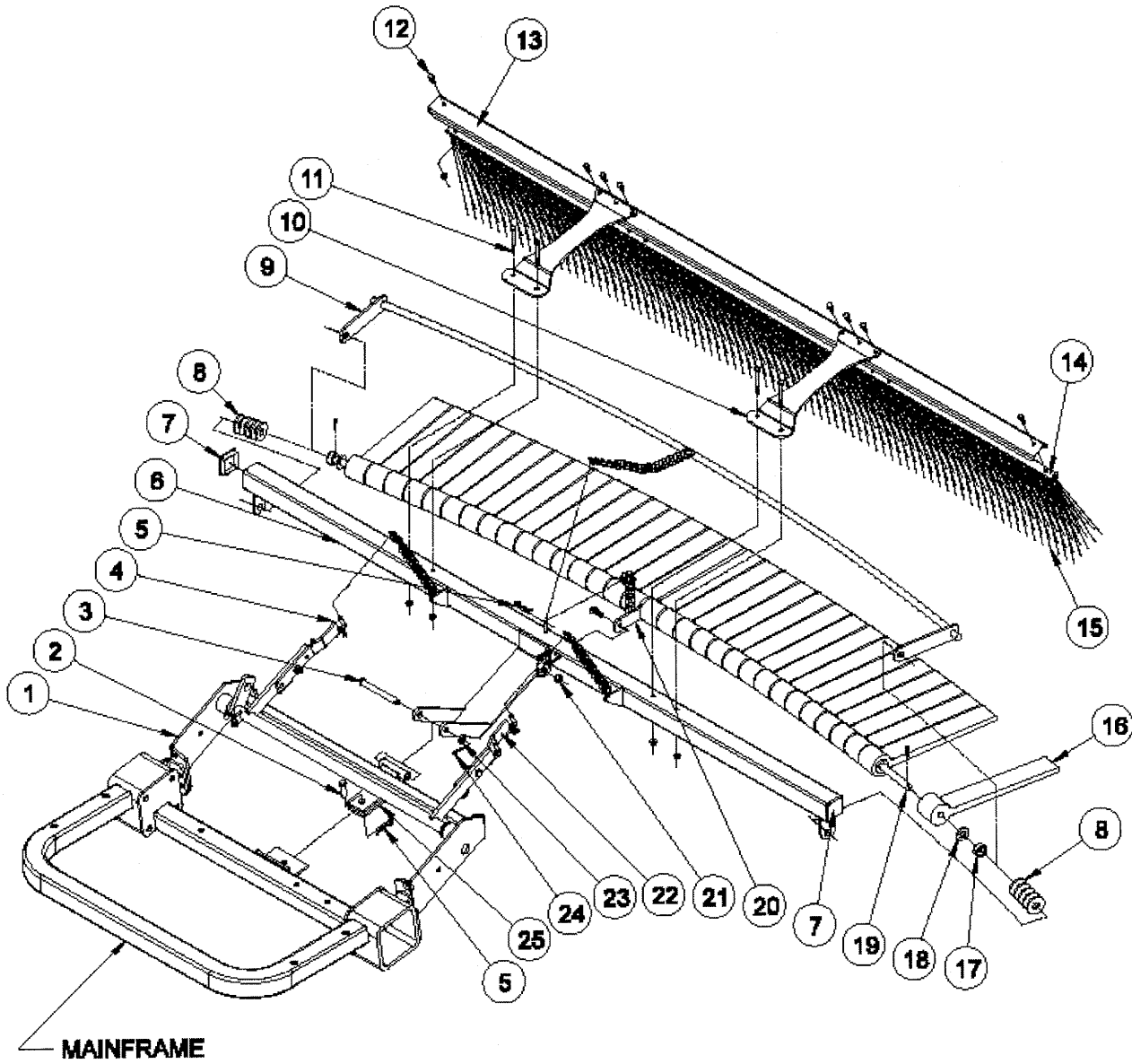

AS

43-002 FLEX ACTION FIELD FINISHER WITH BRUSH INSTRUCTIONS

ASSEMBLY INSTRUCTIONS

1. Install flail bar strap (Ref 20) to center of mounting bar (Ref 19) with chain on top of flail bar strap and mounting bar bent away from you. Apply a light coat of lubricant to overall length of mounting bar.
2. Install one rasp flail (Ref 16) with knobby side down adjacent to sides of flail bar strap (Ref 20). Now install a flat washer (Ref 18) so it sits adjacent with the outside of the rasp flail. Continue to install flails with knobby sides down with washers between until you have 16 flails and washers on each side of bar strap. Force all flails tightly toward bar strap.
3. After all 32 flails have been installed, place one spacer (Ref 17) to each end of mounting bar adjacent to washer.
4. Install leveler bar (Ref 9) to mounting bar, with curved leveler bar resting on top on the smooth sides of flails. If all flails and washers do not fit snugly at this time, remove leveler bar and install enough machine bushings to ensure a snug fit. Then reinstall leveler bar.
5. Lay the frame (Ref 6) on the floor or bench with welded tabs facing up. Install ends of assembled mounting bar, with knobby sides of flails up, into welded tabs on each end of frame and secure with $\frac{1}{8}$ x 1 cotter pin.
6. Install flail bar strap (Ref 20) to center tab on frame with $\frac{3}{8}$ -16 x 1 bolt and $\frac{3}{8}$ -16 center lock nut. Loose fit is required. Do not over tighten.
7. Flip assembly over so knobby sides of flails are now facing down. Install hitch (Ref 25) to frame with clevis pin (Ref 3) and cotter pin (Ref 24). The hitch should be attached to the frame as shown.
8. Install bar strap chain over welded pin on frame. Install leveler bar chain on to pin and secure in place with bridge pin. Use last bridge pin and clevis pin to hitch field finisher to your machine.
9. Add extension arms (Refs 4 & 22) to rake lift. **Super Star** - use the center hole and only (1) $\frac{3}{8}$ -16 x $1\frac{1}{4}$ bolt per arm. **Supreme & Super Rake(see sidebar)** - use the two outside holes on the extension arms and (2) $\frac{3}{8}$ -16 x $1\frac{1}{4}$ bolts per arm. Hook lift chains to extension arms (Refs 4 & 22).

OPERATING INSTRUCTIONS

Running attachment with all flails down, flat on the surface, will provide a leveling function. Running attachment partially raised and flails at a 20° - 40° angle in relation to the level surface, will provide a finishing function. The flails increase down pressure for desired finish. Drive in wide circular patterns and increase or decrease ground speed to achieve desired finish.

BRUSH ASSEMBLY

1. Place the brush (Ref 15) into the brush track (Ref 14). Place the brush channel (Ref 13) between the brush track and the mounting brackets. Now bolt the mounting brackets (Ref 10) to the brush track using the $\frac{1}{4}$ -20 x $\frac{3}{4}$ bolts and $\frac{1}{4}$ -20 flange whiz-lock nuts (Ref 12).
2. Mount the brush assembly to the frame using the (4) $\frac{1}{4}$ -20 x $2\frac{1}{2}$ bolts and $\frac{1}{4}$ -20 flange whiz-lock nuts (Ref 11).

26-008 FLEX ACTION FIELD FINISHER DRAWING

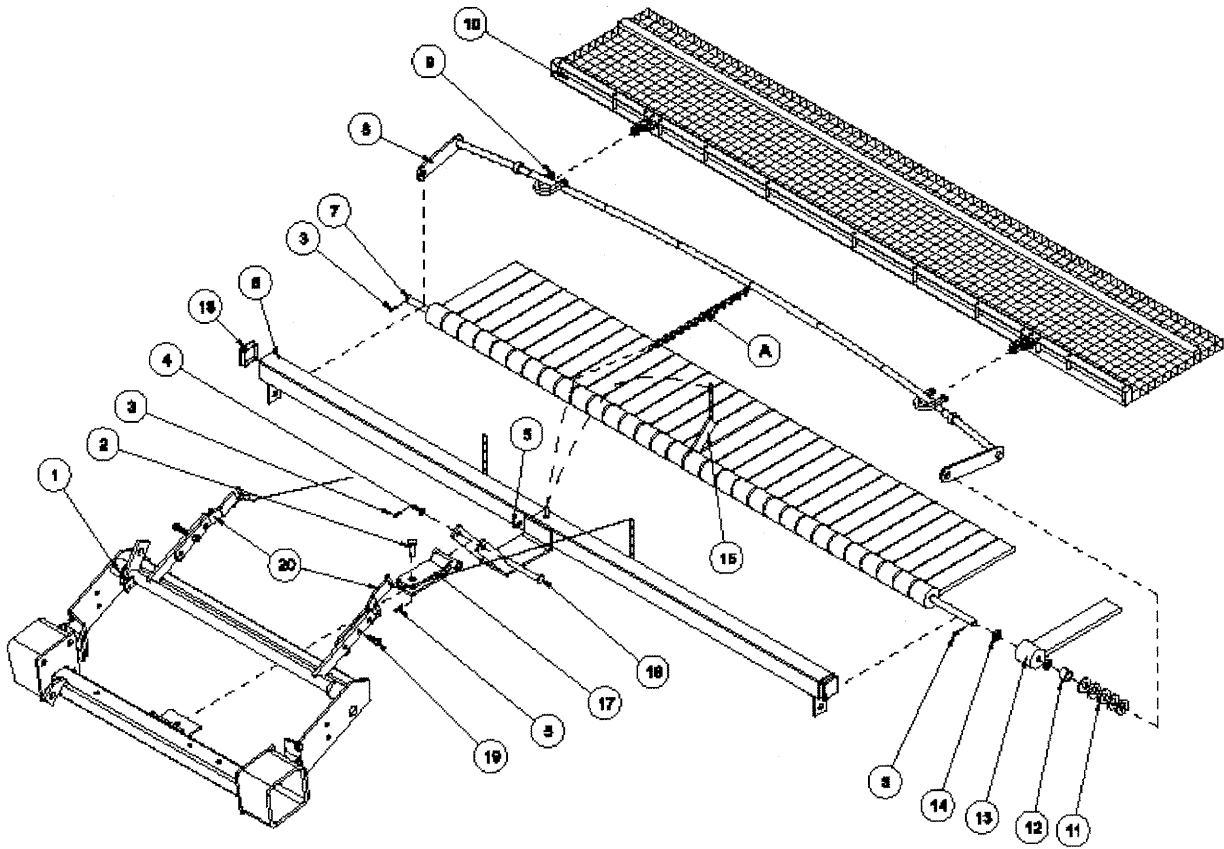

26-008 FLEX ACTION FIELD FINISHER PARTS LIST

REF#	PART#	DESCRIPTION	QUANTITY
1	42-024	Rake Lift (comes with machine)	1
2	HCP-12-150	Clevis Pin $\frac{1}{2}$ x $1\frac{1}{2}$	1
3	HP-18-100	Cotter Pin $\frac{1}{8}$ x 1	3
4	HMB-12-14	Machine Bushing $\frac{1}{2}$ - 14GA	1
5	HHP-18	Bridge Pin $\frac{1}{8}$	2
6	26-046	Frame	1
7	26-049	Mounting Bar	1
8	26-047	Leveler Bar	1
9	21-260	$\frac{3}{8}$ Chain Clevis	2
10	26-115	Mesh Finisher	1
11	HMB-58-14	Machine Bushing $\frac{5}{8}$ x 14GA	10
12	11-040	Spacer $\frac{3}{4}$ "	2
13	26-041	Rasp Flail	32
14	HW-58	Washer $\frac{5}{8}$	32
15	26-048	Flail Bar Strap	1
	HB-38-16-100	Bolt $\frac{3}{8}$ - 16 x 1	1
	HNCL-38-16	Center Lock Nut $\frac{3}{8}$ - 16	1
16	HCP-12-450	Clevis $\frac{1}{2}$ x $4\frac{1}{2}$	1
17	19-107	Hitch	1
18	18-297	Cap Plug	2
19	HB-38-16-125	Bolt $\frac{3}{8}$ - 16 x $1\frac{1}{4}$	4
	HNTL-38-16	Lock Nut $\frac{3}{8}$ - 16	4
20	26-116	Right Extension Arm	1
	26-117	Left Extension Arm	1

26-008 INSTALLATION INSTRUCTIONS

1. Install flail bar (Ref 15) strap to center of mounting bar (Ref 7) with chain on top of flail bar strap and mounting bar bent away from you. Apply a light coat of lubricant to overall length of mounting bar.
2. Install one rasp flail (Ref 13) with knobby side down adjacent to sides of flail bar strap (Ref 15). Now install a flat washer (Ref 14) so it sits adjacent with the outside of the rasp flail. Continue to install flails with knobby sides down with washers between until you have 16 flails and washers on each side of bar strap. Force all flails tightly toward bar strap.
3. After all 32 flails have been installed, place one spacer (Ref 12) to each end of mounting bar adjacent to washer.
4. Install leveler bar (Ref 8) to mounting bar, with curved leveler bar resting on top on the smooth sides of flails. If all flails and washers do not fit snugly at this time, remove leveler bar and install enough machine bushings to ensure a snug fit. Then reinstall leveler bar.
5. Lay the frame (Ref 6) on the floor or bench with weld tabs facing up. Install ends of assembled mounting bar, with knobby sides of flails up, into welded tabs on each end of frame and secure with cotter pin (Ref 3).
6. Install flail bar strap (Ref 15) to center tab on frame with $\frac{3}{8}$ -16 x 1 bolt and $\frac{3}{8}$ -16 center lock nut. Loose fit is required. Do not over tighten
7. Flip assembly over so knobby sides of flails are now facing down. Install hitch (Ref 17) to frame with clevis pin (Ref 16) and cotter pin (Ref 3) . The hitch should be attached to the frame as shown.
8. Install bar strap chain over welded pin on frame. Install leveler bar chain on to pin and secure in place with bridge pin. Use last bridge pin and clevis pin to hitch field finisher to your machine.
9. Add extension arms (Ref 20) to rake lift. **Super Star** - use the center hole and only (2) $1\frac{1}{4}$ bolts (Ref 19). **Supreme & Super Rake** - use the two outside holes on the extension arms and (4) $1\frac{1}{4}$ bolts. Hook lift chains to extension arms (Ref 20).

OPERATING INSTRUCTIONS

Running attachment with all flails down, flat on the surface, will provide a leveling function. Running attachment partially raised and flails at a 20° - 40° angle in relation to the level surface, will provide a finishing function. The flails increase down pressure for desired finish. Drive in wide circular patterns and increase or decrease ground speed to achieve desired finish.

MESH FINISHER

To get a smoother finish, Install a Mesh Finisher onto your Flex Action Field Finisher.

1. If the 26-008 flex action field finisher is on your machine, lower it to the ground. You may have to pull machine ahead slightly so the field finisher is lying flat on the ground or floor.
2. Lay mesh finisher behind field finisher with weight bar facing up and chain hooks towards field finisher.
3. Take the two chain clevis' and hook onto leveler bar and then thorough the chain hooks on mesh finisher. The clevis pin that comes with the chain clevis should go through the chain clevis, first link on chain hook (on the mesh finisher) and then through other side of the chain clevis. Insert the cotter pin.
4. Center mesh finisher with flex action field finisher.
5. Raise lift on your machine to insure proper ground clearance before driving your machine.
6. (Ref A) Chain length is to control amount of mesh trailing behind flails for wet or dry conditions. For wet conditions: Shorten chains. For dry conditions: May use maximum amount of chain to make desired finish.

43-043 FINISHING BRUSH KIT DRAWING

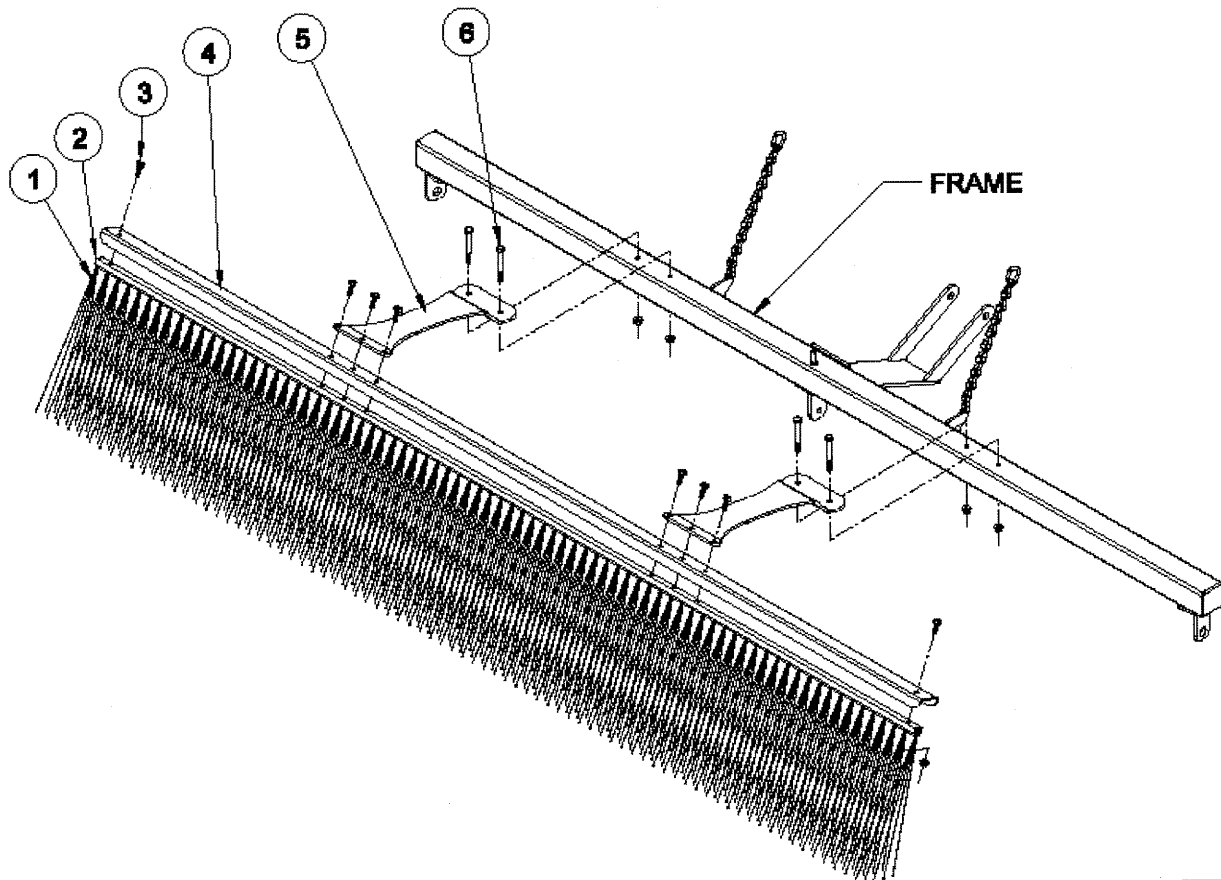

HOLE LOCATION

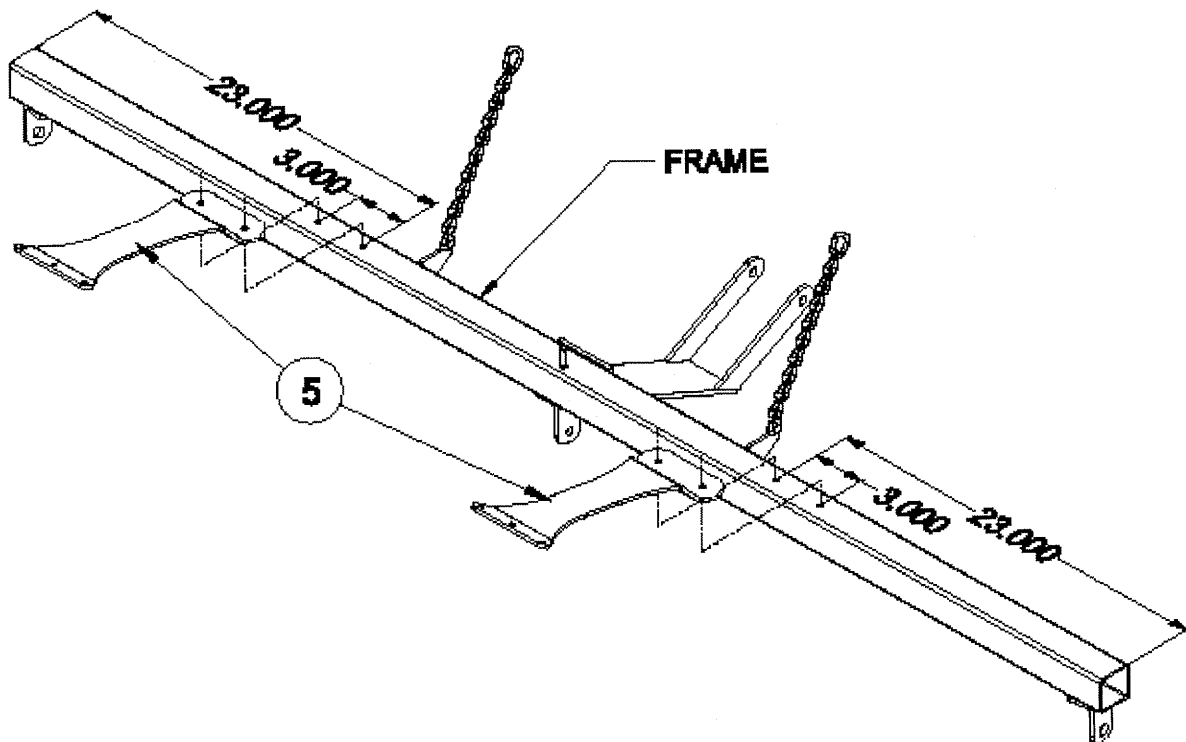

43-043 FINISHING BRUSH KIT PARTS LIST

REF#	PART#	DESCRIPTION	QUANTITY
1	13-682	Brush, 77 x 11	1
2	13-683	Brush Track	1
3	HB-14-20-075	Bolt, 1/4 - 20 x 3/4	8
	HNFL-14-20	Flange Whiz-Lock Nut, 1/4 - 20	8
4	13-688	Brush Channel	1
5	43-041	Mount Bracket	2
6	HB-14-20-250	Bolt, 1/4 - 20 x 2 1/2	4
	HNFL-14-20	Flange Whiz-Lock Nut, 1/4 - 20	4

INSTALLATION INSTRUCTIONS

1. Remove the mesh finisher from your unit, it will not be used with the brush.
2. Place the brush (Ref 1) into the brush track (Ref 2). Place the brush channel (Ref 4) between the brush track and the mounting brackets (Ref 5). Now bolt the mounting brackets (Ref 5) to the brush track using the 1/4 - 20 x 3/4" bolts and 1/4 - 20 flange whiz-lock nuts (Ref 3).
3. Four holes need to be drilled into the frame of the Flex Action Finisher to mount the brush. Drill two $\text{Ø}^{9/32}$ holes 23" in from each end and 3" apart (see Reference drawing).
4. Mount the brush assembly to the frame using the four 1/4 - 20 x 2 1/2" bolts and 1/4 - 20 flange whiz-lock nuts (Ref 5).

42-582 GREEN STAR RBS SPIKER SET (3) DRAWING

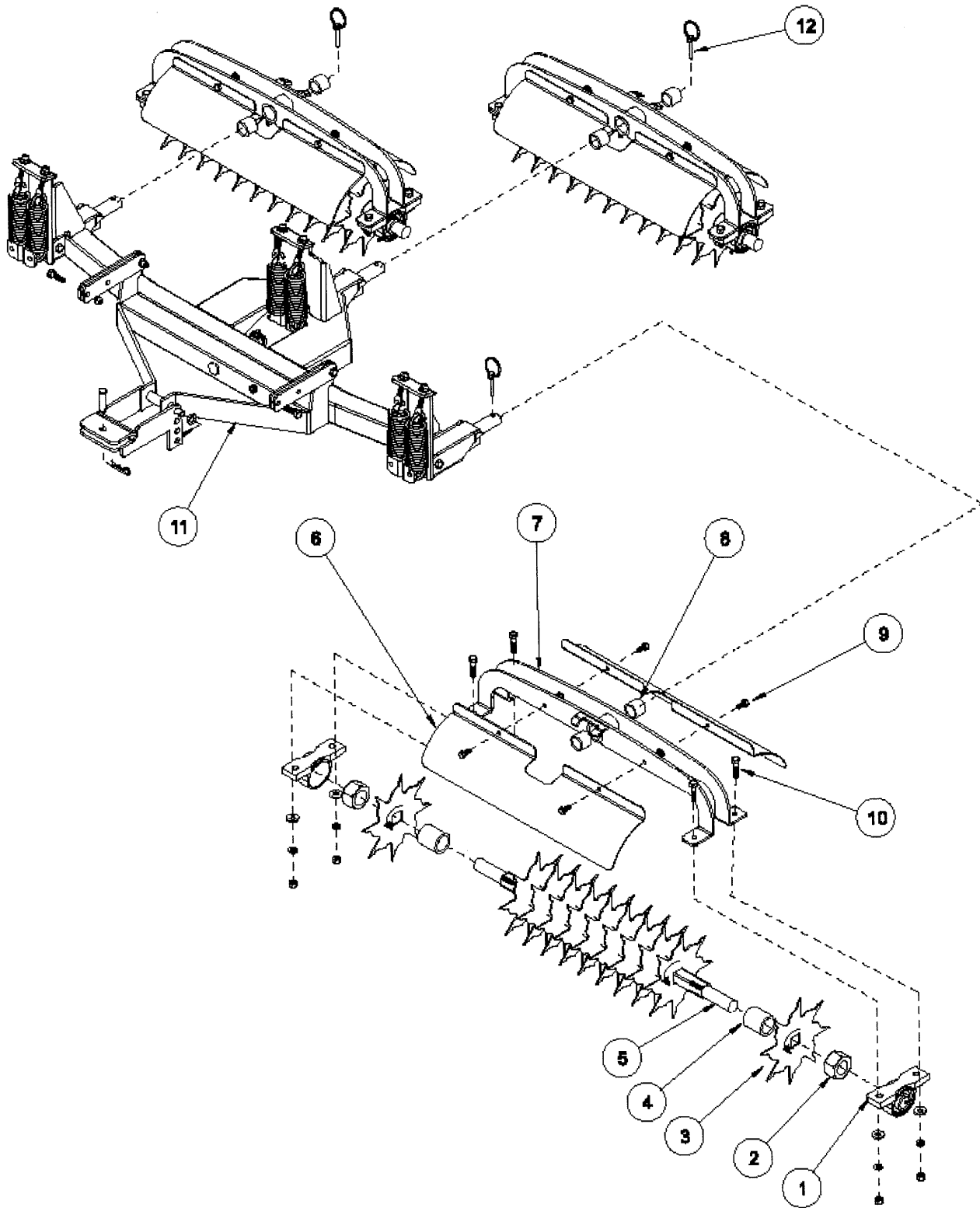

42-582 GREEN STAR RBS SPIKER SET (3) PARTS LIST

REF#	PART#	DESCRIPTION	QUANTITY
1	11-094	Pillow Block	6
2	HNJ-114-12	Jam Nut 1 ¹ / ₄ - 12	6
3	42-583	Spiker Blade	33
4	8965-1.875	Spiker Blade Spacer (1.875")	30
5	42-554	Spiker Shaft	3
6	42-578	Spiker Cover	6
7	42-574	Fork	3
8	18-295	Oilite Bushing (part of 42-574)	6
9	HB-516-18-075	Bolt ⁵ / ₁₆ - 18 x ³ / ₄	12
	HNTL-516-18	Lock Nut ⁵ / ₁₆ - 18	12
10	HB-38-16-150	Bolt ³ / ₈ - 16 x 1 ¹ / ₂	12
	HWL-38	Lock Washer ³ / ₈	12
	HW-38	Washer ³ / ₈	24
	HN-38-16	Nut ³ / ₈ - 16	12
11	42-586	Green Star RBS Main Frame	1
12	42-539	Lynch Pin ⁵ / ₁₆ (part of main frame)	3

ADJUSTMENTS AND OPERATION INSTRUCTIONS

ADJUSTMENT

The springs are preset for maximum down pressure, and should not need to be adjusted. If you feel the need to adjust the springs please call for further instructions. The unit comes pre-adjusted for most models. When installing spiker system use lower mounting holes on hitch.

Tire pressure should be 4 psi in the front and 7 psi in the rear tire for best traction.

OPERATION

Make sure the spiker system has been installed and adjusted properly for your model of bunker rake. Always transport in fully raised position. Always remove flag pole before spiking green. Do not stop on green while spiking. Do not spike up steep slopes or loss of traction may result. Do not turn while spiking.

To begin spiking, lower unit all the way down as you come across collar and continue straight across green until reaching other collar and raise as you come off of green. Overlap stripes the same as if you were mowing.

INSTALLATION

Spiker blades must be installed so that the jagged side of the tooth cuts into the turf first. This allows only a piercing of the turf, whereas if the straight edge of the spiker blades enters first it will act more as a cutting effect.

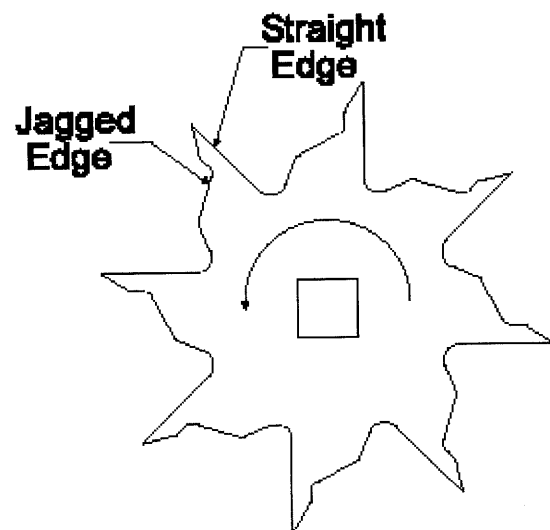

42-586 GREEN STAR RBS MAIN FRAME DRAWING

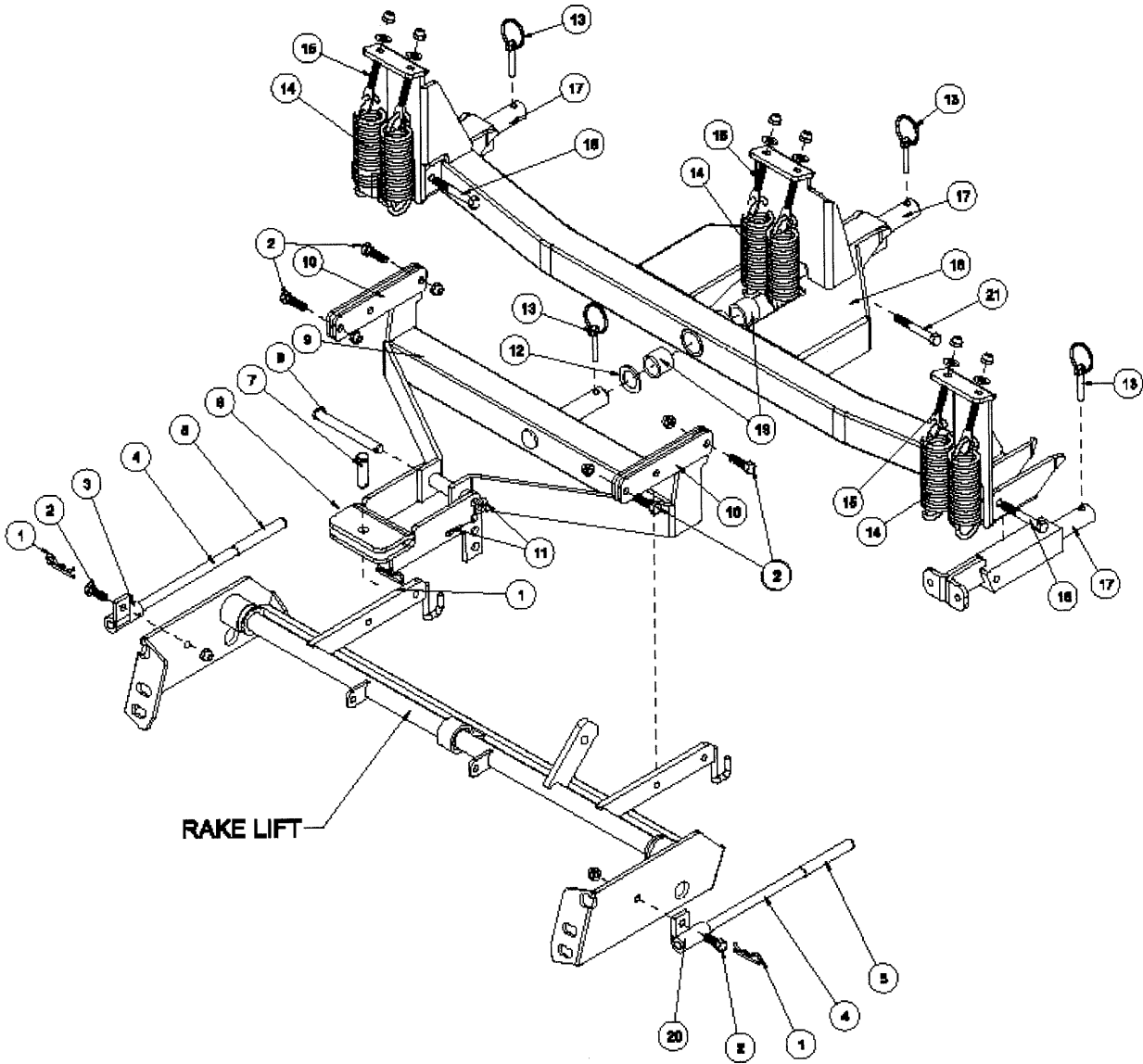

42-586 GREEN STAR RBS MAIN FRAME PARTS LIST

REF#	PART#	DESCRIPTION	QUANTITY
1	HHP-18	Bridge Pin $\frac{1}{8}$	3
2	HB-38-16-125	Bolt $\frac{3}{8}$ - 16 x $1\frac{1}{4}$	6
	HNTL-38-16	Lock Nut $\frac{3}{8}$ - 16	6
3	42-525	Right Rod Holder	1
4	42-580	Stabilizer Rods	2
5	13-499	Grip	2
6	42-565	Hitch	1
7	HCP-12-175	Clevis Pin $\frac{1}{2}$ - $1\frac{3}{4}$	1
8	HCP-12-450	Clevis Pin $\frac{1}{2}$ - $4\frac{1}{2}$	1
9	42-575	Three Point Hitch	1
10	42-566	Lift Strap	4
11	HMB-12-14	Machine Bushing $\frac{1}{2}$ x 14GA	1
	HP-18-100	Cotter Pin $\frac{1}{8}$ x 1	1
12	HMB-100-14	Machine Bushing 1 x 14GA	1
13	42-539	Lynch Pin $\frac{5}{16}$	4
14	42-536	Spring	6
15	42-537	Spade Bolt	6
	HNTL-38-16	Lock Nut $\frac{3}{8}$ - 16	6
16	42-577	Frame	1
17	42-576	Spring Tower	3
18	HB-38-16-275	Bolt $\frac{3}{8}$ - 16 x $2\frac{3}{4}$	2
	HNTL-38-16	Lock Nut $\frac{3}{8}$ - 16	2
19	18-295	Oilite Bushing (part of 42-577)	2
20	42-524	Left Rod Holder	1
21	HB-38-16-250	Bolt $\frac{3}{8}$ - 16 x $2\frac{1}{2}$	1
	HNCL-38-16	Center Lock Nut $\frac{3}{8}$ - 16	1

GREEN STAR RBS MOUNT FOR SMITHCO SUPER STAR E 48V

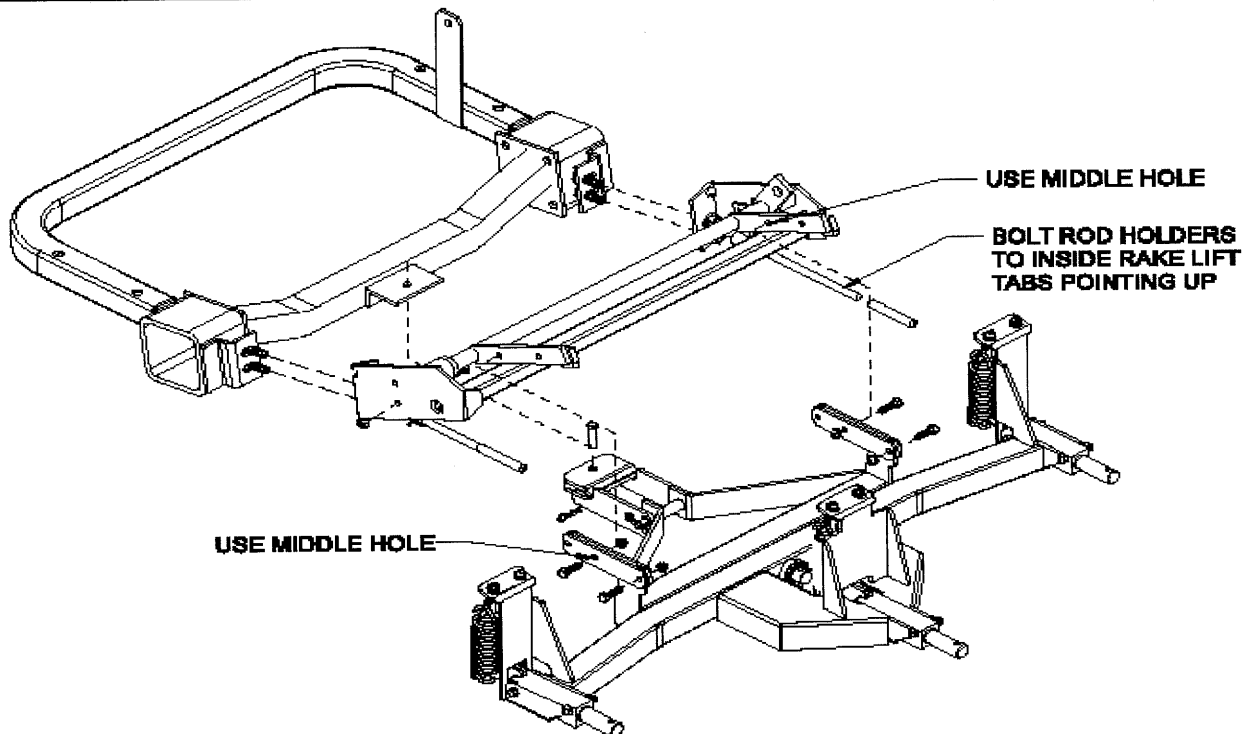

42-800 ROLL OVER PROTECTION DRAWING

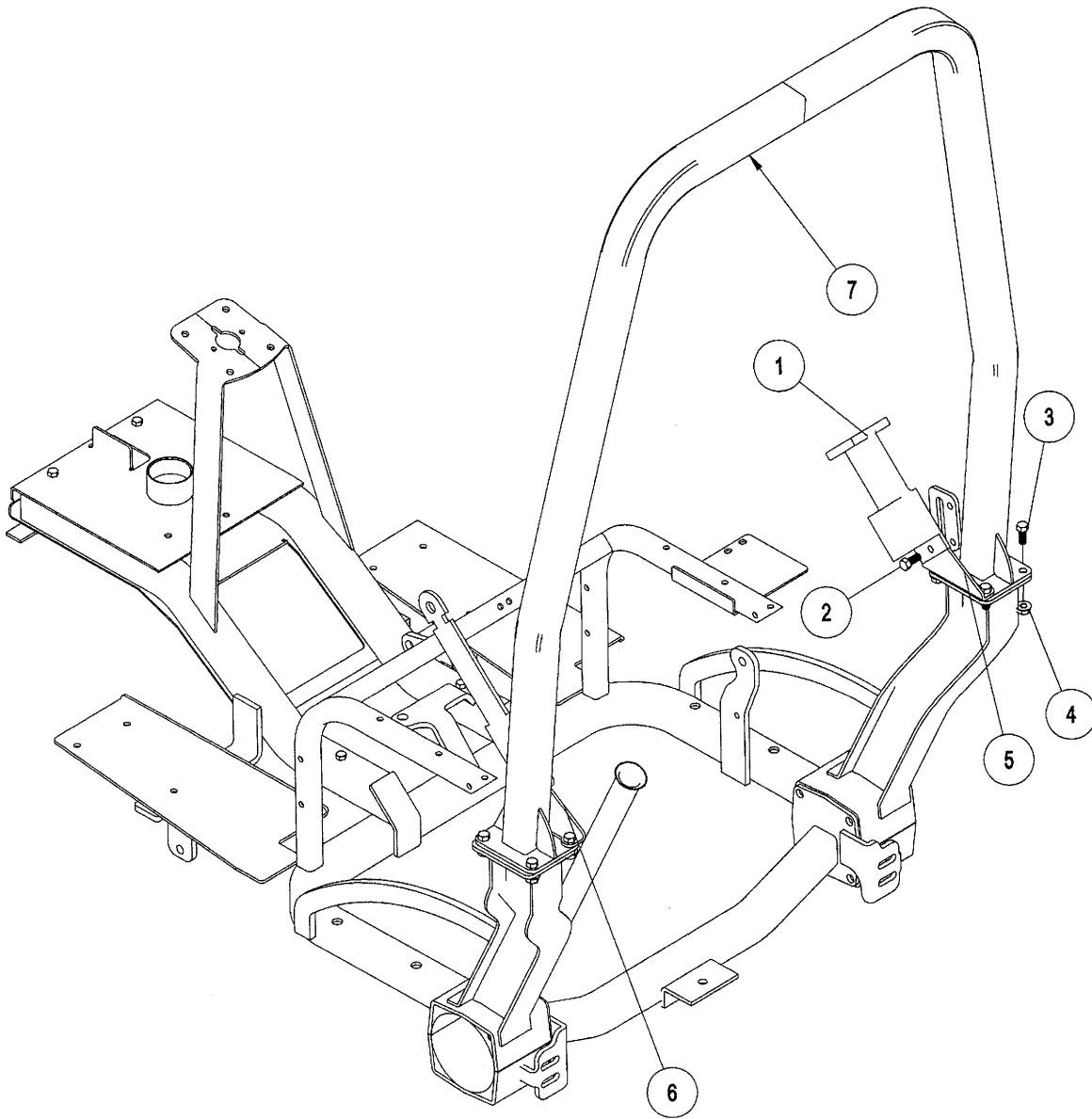

42-800 ROP PARTS LIST

REF#	PART#	DESCRIPTION	QTY.
1	76-198-03	Seat Belt	1
2	HB-716-14-100	Bolt 7/16-14 x 1"	2
3	HB-716-14-125	Bolt 7/16 - 14 x 1 1/4"	8
4	HNTL-716-14	Lock Nut 7/16 - 14	10
5	42-802	Right Seat Belt Bracket	1
6	42-803	Left Seat Belt Bracket	1
7	42-801	ROPS Bar	1

42-800 INSTALLATION INSTRUCTIONS

The following ROP instructions apply to all Super Star Machines.

After wheels are mounted and machine is all set up.

1. Line up the mount plate on the ROPS to the square mounting plate by the seat, with the bend in the ROP bar toward the rear of the machine.
2. Place four bolts in the outside mount plate holes and tighten.
3. Place the seat belt brackets over the inside mount holes and bolt in place with the remaining four bolts. The seat belt brackets are mounted with the bends to the outside and the holes to the front.
4. Mount seat belts onto seat belt bracket. The strap goes on the left side and the lock goes on the right side.
5. Tighten all hardware.

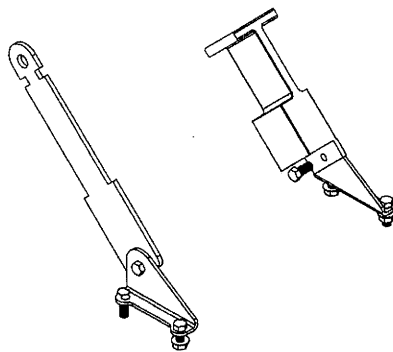

ROPS have been certified to meet OSHA 1928.52 and seat belts are certified to OSHA 1928.51. ROPS come standard on Diesel Super Star 43-000-B starting serial number 14068.

42-800 PACKING LIST

PART#	DESCRIPTION	QTY.
76-198-03	Seat Belt	1
HB-716-14-100	Bolt 7/16 – 14 x 1”	2
HB-716-14-125	Bolt 7/16 – 14 x 1 ¼”	8
HNTL-716-14	Lock Nut 7/16 – 14	10
42-802	Right Seat Belt Bracket	1
42-803	Left Seat Belt Bracket	1
42-801	ROPS Bar	1

The Smithco Commercial Products Two-Year Limited Warranty

Smithco, Inc. (Smithco) warrants your 2007 or newer Smithco Commercial Product ("Product") purchased after January 1, 2007, to be free from defects in materials or workmanship for the period of time listed below. Where a warrantable condition exists, Smithco will repair the Product at no cost to you including diagnosis, labor (at the Smithco standard labor rate, subject to the Smithco flat rate schedule), and parts.

Warranty Duration Is:

1. Two years, 1500 operational hours* from the date of delivery to the original purchaser or three years from the date of original manufacturer of the product, whichever occurs first. (*Products equipped with hour meter).
2. Products used in rental situations are covered for 90 days from date of delivery to original user/renter.

Owner responsibilities:

As the Product owner, you are responsible for required maintenance and adjustments stated in your Owner's Manual. Failure to perform required maintenance and adjustments can be grounds for disallowing a warranty claim. **You are particularly responsible to train all present and future operators of this product on the safe operation of this product at your location.**

Instructions for Obtaining Warranty Service:

You are responsible for notifying the Authorized Smithco Products Distributor from whom you purchased the Product as soon as you believe a warrantable condition exists and not later than 30 days from discovery of the condition.

If you need help locating an Authorized Smithco Distributor, or if you have questions regarding your warranty rights or responsibilities, you may contact us at:

Smithco Product Support Department
Highway SS @ Poplar St.
Cameron, Wisconsin 54822
Telephone: 715-458-4192 E-Mail: ProductSupport@Smithco.com

Maintenance Parts:

Parts scheduled for replacement as required maintenance ("Maintenance Parts"), are warranted for the period of time up to the scheduled replacement time for that part.

Items/Conditions Not Covered:

Not all product failures or malfunctions that occur during the warranty period are defects in materials or workmanship. The items/conditions listed below are not covered by this warranty.



Product failures which result from the use of non-Smithco replacement parts, or from installation and use of add-on, modified, or unapproved accessories are not covered.



Product failures which result from failure to perform required maintenance and/or adjustments are not covered.



Product failures that result from operating the Product in an abusive, negligent or reckless manner are not covered.



This warranty does not apply to parts subject to consumption through use, unless found to be defective. Examples of parts which are consumed, or used up during normal Product operation include, but are not limited to: blades, tines, teeth, scarifiers, rakes, plates, wear plates, castor wheels, tires, batteries, filters, belts, nozzles, etc.



This warranty does not apply to failures caused by outside influence. Items considered to be outside influence include, but are not limited to, weather, storage practices, contamination, use of unapproved coolants, lubricants, additives, or chemicals, etc.



This warranty does not apply to normal "wear and tear" items. Normal "Wear and Tear" includes, but is not limited to, damage to seats due to wear or abrasion, worn painted surfaces, scratched decals or windows, etc.



Smithco may require the return of failed parts or components in order determine the validity of any warranty claim.



Smithco will not be obligated to replace components of other manufacturers if inspection by the original component manufacturer indicates that failure was due to normal wear and tear, expected consumption through use or improper care or service.

Other Legal Disclaimers:

The above remedy for product defects through repair or replacement by an authorized Smithco distributor or dealer is the purchaser's sole remedy for any defect. This warranty gives you specific legal rights, and you may also have other rights which vary from state to state.

THERE ARE NO OTHER EXPRESS WARRANTIES OTHER THAN THOSE SET FORTH ABOVE. ALL IMPLIED WARRANTIES OF MERCHANTABILITY AND FITNESS FOR USE ARE LIMITED TO THE DURATION OF THE LIMITED WARRANTIES CONTAINED HEREIN.

Some States may not allow limitations on how long an implied warranty lasts, so the above limitation may not apply to you.

THE SMITHCO COMPANY IS NOT LIABLE FOR INDIRECT, INCIDENTAL OR CONSEQUENTIAL DAMAGES IN CONNECTION WITH THE USE OF THE PRODUCT, INCLUDING ANY COST OR EXPENSE OF PROVIDING A SUBSTITUTE PRODUCT OR SERVICE DURING PERIODS OF MALFUNCTION OR NON-USE.

Some states may not allow the exclusion of indirect, incidental or consequential damages, so the above exclusion may not apply to you.

Smithco neither assumes, nor authorizes any person to assume for it, any other liability in connection with the sale or use of this product.

**SMITHCO, INC.
WANYE, PA 19087**

