

Parts & Service  
Operators



# 60" & 78" AER 8 Aerifier

Serial#: AER60-005  
AER78-005

July 2012

**Product Support:**

**Hwy 55 & Poplar Ave; Cameron WI 54822  
1-800-891-9435    productsupport@smithco.com**

# CONTENTS

Introduction

|                           |            |
|---------------------------|------------|
| <b>Introduction .....</b> | <b>1-7</b> |
| Introduction .....        | 1          |
| Safe Practices .....      | 2          |
| Specifications .....      | 3          |
| Accessories .....         | 3          |
| Setup .....               | 4-6        |
| Operation .....           | 7          |

Service

|                      |             |
|----------------------|-------------|
| <b>Service .....</b> | <b>8-11</b> |
| Maintenance .....    | 8-10        |
| Storage .....        | 11          |

Diagrams

|   |              |
|---|--------------|
| <b>Parts .....</b>                            | <b>12-33</b> |
| AER8-001 Hydraulic Transport Frame .....      | 12           |
| AER8-003 Hydraulic Hose Kit .....             | 13           |
| AER8-002 Electric/Hydraulic Lift System ..... | 14-15        |
| AER8 Charging Harness .....                   | 16           |
| 3-Point Hitch .....                           | 17           |
| Turf Quake Tine 5" Spacing .....              | 18-19        |
| Turf Quake Tine 7.5" Spacing .....            | 20-21        |
| All-Star Tine 5" Spacing .....                | 22-23        |
| All-Star Tine 7.5" Spacing .....              | 24-25        |
| AerFine Tine 3" Spacing .....                 | 26-27        |
| AerFine Tine 5" Spacing .....                 | 28-29        |
| Coring Tine .....                             | 30-31        |
| Rear Roller .....                             | 32-33        |

Parts

|   |           |
|---|-----------|
| <b>Reference .....</b>                  | <b>34</b> |
| Decal List .....                        | 34        |
| Quick Reference Replacement Parts ..... | 34        |

Accessories

Reference

Thank you for purchasing a **Smithco** product.

Read this manual and all other manuals pertaining to the Aer-8 Aerifier carefully as they contain safety, operating, assembly and maintenance instructions. Failure to do so could result in personal injury or equipment damage.

Keep manuals in a safe place after operator and maintenance personnel have read them. Right and left sides are from the operator's seat, facing forward.

All **Smithco** machines have a Serial Number and Model Number. Both numbers are needed when ordering parts. The serial number plate on the Aer-8 is located on the left top main frame.

For easy access record your Serial and Model numbers here.

|  |                      |                      |
|--|----------------------|----------------------|
| <b>SMITHCO</b>   |                      | DATE OF MFG.         |
| WAYNE, PENNSYLVANIA 19087 USA<br>610-688-4009 Fax 610-688-6069 |                      | <input type="text"/> |
| SERIAL NO.   | kW/hp                |                      |
| <input type="text"/>   | <input type="text"/> |                      |
| MODEL NO.  | kg/lb                |                      |
| <input type="text"/>   | <input type="text"/> |                      |

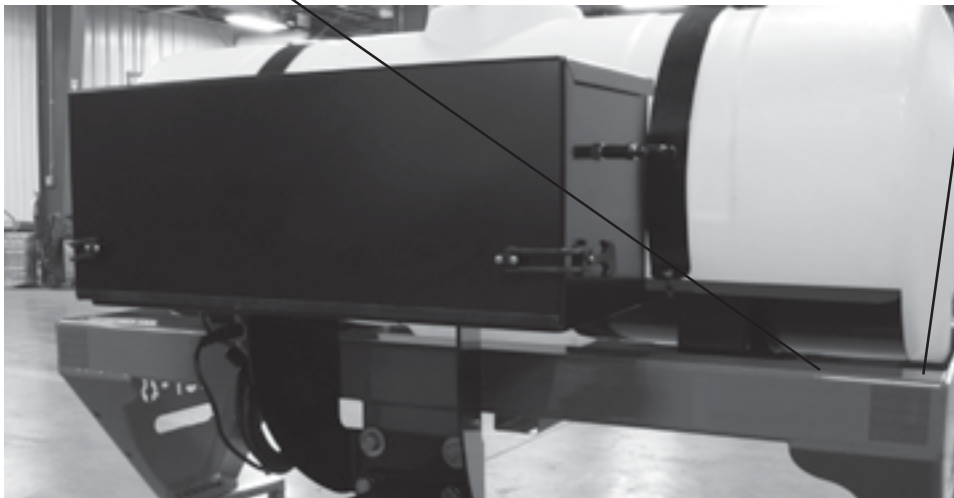

Information needed when ordering replacement parts:

1. Model Number of machine
2. Serial Number of machine
3. Name and Part Number of part
4. Quantity of parts

## SAFE PRACTICES

1. It is your responsibility to read this manual and all publications associated with this machine.
2. Never allow anyone to operate or service the machine or its attachments without proper training and instructions. Never allow minors to operate any equipment.
3. Learn the proper use of the machine, the location and purpose of all the controls before you operate the equipment. Working with unfamiliar equipment can lead to accidents.
4. Wear all the necessary Personal Protective Equipment (PPE) to protect our head, eyes, ears, hands and feet. Operate the machine only in daylight or in good artificial light.
5. Inspect the area where the equipment will be used. Beware of overhead obstructions and underground obstacles. Stay alert for hidden hazards.
6. Never operate equipment that is not in perfect working order or without decals, guards, shields, or other protective devices in place.
7. Never disconnect or bypass any switch.
8. When working around the tines, frame **must be** supported.
9. Never use your hands to search for oil leaks. Hydraulic fluid under pressure can penetrate the skin and cause serious injury.
10. This machine demands your attention. To prevent loss of control or tipping of the vehicle:
  - A. Use extra caution in backing up the vehicle. Ensure area is clear.
  - B. Do not stop or start suddenly on any slope.
  - C. Reduce speed on slopes and in sharp turns. Use caution when changing directions on slopes.
  - D. Stay alert for holes in the terrain and other hidden hazards.
  - E. Operate equipment up and down slopes, never across the face.
  - F. Before unhitching, lower jack stands and secure pins.
11. Before leaving operator's position for any reason:
  - A. Disengage all drives.
  - B. Lower all attachments to the ground.
  - C. Shut engine off and remove the ignition key.
12. Keep hands, feet and clothing away from moving parts. Wait for all movement to stop before you clean, adjust or service the machine.
13. Keep the area of operation clear of all bystanders.
14. Never carry passengers.
15. Use parts and materials supplied by **Smithco** only. Do not modify any function or part.
16. Avoid sharp turns. Watch the tires of the tractor while turning to make sure they do not contact the tongue of the Aer-8.
17. Shut down power source before attempting to unclog any part of the machine.
18. Know where and how deep all gas, water and electrical lines are buried.

***These machines are intended for professional maintenance on golf courses, sports turf, and any other area maintained turf and related trails, paths and lots. No guaranty as to the suitability for any task is expressed or implied.***

## SPECIFICATIONS FOR AER-8

|                               |  |                                       |
|-------------------------------|--|---------------------------------------|
| WEIGHTS AND DIMENSIONS        | 60"  | 78"                                   |
| Length                        | 46" (117 cm)   |                                       |
| Width                         | 63" (1637 cm)  | 81" (205 cm)                          |
| Height                        | 55" (140 cm)   |                                       |
| Weight                        | 790 lb (358 kg)  |                                       |
| Weight (with transport frame) | Empty - 1225 lb (556 kg)<br>Full - 2085 lb (946 kg)        | 1475 lb (668 kg)<br>2330 lb (1056 kg) |
| TIRES & WHEELS                | Two 18 x 9.5 x 8 ( 20 psi (1.4 bar))                       |                                       |
| BATTERY <b>(Not Included)</b> | Automotive type 24F-12 Volt                                |                                       |
| BCI Group                     | Size 24  |                                       |
| Cold Cranking Amps            | 900 minimum  |                                       |
| Ground Terminal Polarity      | Negative (-)   |                                       |
| Maximum Length                | 10.25" (26 cm)   |                                       |
| Maximum Width                 | 6.88" (17 cm)  |                                       |
| Maximum Height                | 10" (25 cm)  |                                       |
| FLUID CAPACITY                |  |                                       |
| Hydraulic Fluid               | 1.25 Gal (4.3 liter)                                       |                                       |
| TOW VEHICLE                   |  |                                       |
|                               | For 3-Point on 60" must be able to support 1350lb (613 kg) |                                       |
|                               | For 3-Point on 78" must be able to support 1850lb (839 kg) |                                       |
|                               | Minimum drawbar power of 20 HP (15 kW)                     |                                       |
|                               | Heavy Duty Vehicle with 4 wheel brakes                     |                                       |
|                               | Capable of 825 lb (374 kg) tongue weight.                  |                                       |

## ACCESSORIES

### TINE REEL ASSEMBLIES FOR REPLACING ENTIRE TINE REEL ASSEMBLY

| 60"         | 78"         |  |
|-------------|-------------|--|
| AER8-60R601 | AER8-78R781 | Turf Quake Fracture Tine Reel Assembly 5" Spacing    |
| AER8-60R602 | AER8-78R782 | Turf Quake Fracture Tine Reel Assembly 7.5" Spacing  |
| AER8-60R603 | AER8-78R783 | All Star Sport Field Tine Reel Assembly 5" Spacing   |
| AER8-60R604 | AER8-78R784 | All Star Sport Field Tine Reel Assembly 7.5" Spacing |
| AER8-60R605 | AER8-78R785 | Aerfine Thin Blade Tine Reel Assembly 3" Spacing     |
| AER8-60R606 | AER8-78R786 | Aerfine Thin Blade Tine Reel Assembly 5" Spacing     |
| AER8-60R607 | AER8-78R787 | Coring Tine Reel Assembly                            |
| AER8-610    | AER8-710    | Rear Roller Assembly                                 |

### COMMON ACCESSORIES

|          |   |
|----------|---|
| AER8-001 | Transport Frame Assembly (must also select Aer8-002 or Aer8-003)      |
| AER8-002 | Electric/ Hydraulic Lift Assembly for Aer8-001 (Battery not included) |
| AER8-003 | Hydraulic Hose Kit for Aer8-001                                       |



## SETUP

The Aerifier arrives from **Smithco** banded on a pallet.

1. Tow vehicle with 3-point hitch will be needed to transport the Aerifier.
2. If transport package is ordered the tongue hitch will need to be installed.
3. Remove tongue from pallet. Install the tongue and place jack in upright position.
4. Crank the jack up so you can hook to tow vehicle.
5. Check the tire pressure. 20 psi (1.4 bar).
6. Check hydraulic fluid level in tank on tow vehicle or the electric/hydraulic lift system if purchased.
7. Machine should be greased before starting. See Maintenance part of manual.
8. Read operating instructions before starting.
9. If using electrical /hydraulic lift system, battery must be installed. (Battery not included)

Use Automotive type 24F-12 Volt

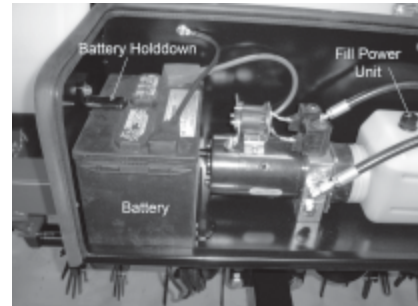
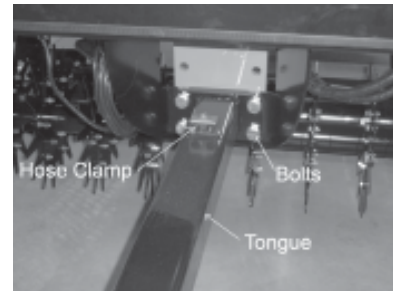

### 3-POINT HITCH ATTACHMENT



**WARNING**

**Excessive weight in the ballast tank on the 3-point hitch models will result in the loss of tow vehicle stability and steering capability. If this occurs front counter balancing on the tow vehicle or Aer8-001 Transport Frame Assembly must be installed. Maximum ballast weight is 200 lbs. per ft. of machine width.**

1. The Aer-8 must be able to "float". The tractor must be equipped with a "float" position on the lower link arms. The "float" position will allow the tines to "float" upwards when an obstruction such as a rock is contacted. This will reduce tine damage.
2. The Aer-8 must be held in an upright and level position by the jack legs prior to hitching to a tractor.
3. Back up the tractor until the lower arm ball joints are inside the frame lift brackets.
4. Install the proper class link pins and quick pins to hold both arms to the frame.
5. Attach the upper 3-point arm between the center tabs on the frame and hold in place with the proper class link pin and lynch pin.
6. Once attached to the 3-point, adjust the lower arms so there is no excessive sway.

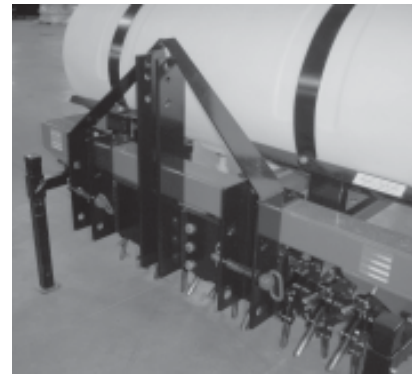

**DANGER**

**Tines are sharp. Keep hands and feet away from reel.**

7. Lift the Aer-8 hydraulically and then retract the jack legs.
8. Lower the Aer-8 hydraulically to the ground and adjust the upper 3-point arm until the Aer-8 column is perpendicular to the ground.
9. From the rear of the aerifier, add water to the ballast tank until the full depth of the tine penetration is reached. The amount of water used is determined by soil type, moisture content and amount of compaction present.





If the combined weight of the Aer-8 and full ballast exceeds the hydraulic lift capacity of the tow vehicles 3-point hitch, then an Aer8-001 Transport Frame Assembly must be installed.

#### TRANSPORT ASSEMBLY ATTACHMENT

**NOTE:** If you purchased a Aer8-001 Transport frame Assembly with your base Aer-8 Aerator it will come installed with the exception of the tongue.

1. Use the supplied bolts to install the tongue to the frame. There are 6 holes to bolt the tongue to. Use 4 holes that best support your tow vehicle.
2. Install tongue with hose clamp on the top. Place swivel jack in the upright position to supply support to the tongue until you have hooked it up to you tow vehicle.
3. Check tire pressure of the tires (20 psi (1.4 bar)).
4. Hook the rear cylinder if not already done. There is a cylinder lockout attached to the rear pivot arm. This is a security guard used when the cylinder needs to be extended for a long period of time, such as maintenance. Placed over the cylinder rod when it is fully extended and pin in place. When not in use return to rear pivot arm.

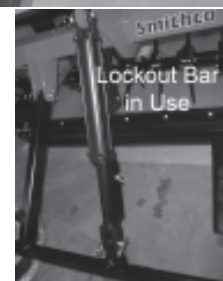
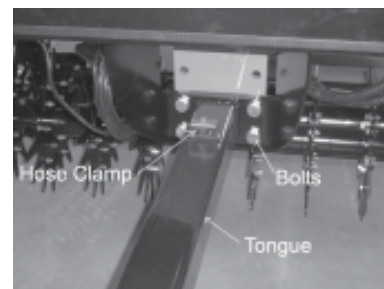

#### ELECTRIC/HYDRAULIC LIFT SYSTEM

**NOTE:** If you purchased a Aer8-002 Electric/hydraulic Lift System with your base Aer-8 Aerator it will come installed. Battery not included.

1. Install an Automotive type 24F-12 Volt battery into the Motor Box and secure with the battery hold-down.
2. Fill the power unit with approximately 1.25 gallons (4,73 l) of Universal Trans-Draulic Oil.
3. Hydraulic fittings and hoses should be attached to the cylinder. If not, short hose to the top port and long hose goes to the bottom port.
4. Route the hoses through the trough below the ballast tank, secure in the hose clamps on the top of the tongue.

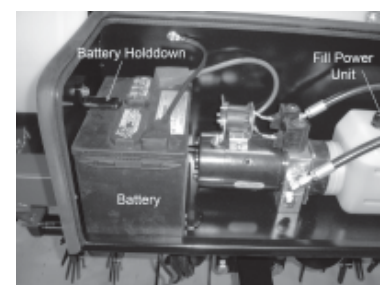

## SET UP

### HYDRAULIC HOSE KIT

**NOTE:** If you purchased a Aer8-003 Hose Kit with your base Aer-8 Aerator it will come un-installed. Quick Couplers from hose to tow vehicle are not included.

1. You will have to supply your own quick couplers to attach hydraulic hoses to your tow vehicle.
2. Hydraulic fittings and hoses should be attached to the cylinder. If not, connect one end of hoses to the cylinder.
3. Route the hoses through the trough below the ballast tank, secure in the hose clamp on the top of the tongue.
4. Connect opposite end to the tow vehicle with quick couplers (not provided).







In excessive stony conditions reduce operating speed.

1. Attach Aer-8 to tow vehicle.
2. Fill ballast tank.
3. Check for any leaks before heading to turf.
4. Lower Aer-8 into the ground so tine penetrate the soil to desired depth.
5. Drive the tow vehicle at speeds that are safe.
6. **Do Not** make sharp turns with the tines in the ground. Lift Aer-8 out of the ground when making sharp turns.
7. Compacted areas may have to be aerated more than once.
8. When Aer-8 is not in use, remove jack pins, extend legs to maximum extension, replace jack pins.



#### CYLINDER LOCKOUT BAR

There is a cylinder lockout attached to the rear pivot arm. This is a security guard used when the cylinder needs to be extended for a long period of time, such as for maintenance. Placed over the cylinder rod when it is fully extended and pin in place. When not in use return to rear pivot arm for storage.

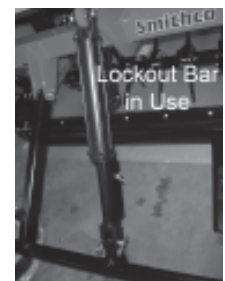

## MAINTENANCE



Before servicing or making adjustments to machine, stop engine on tow vehicle and remove key from ignition. Securely prop Aer-8 on jack stands.

### NOTE:

Use all procedures and parts prescribed by the manufacturer.

Before operating this machine, become familiar with all controls and functions of this unit and the tow vehicle. Also complete all maintenance requirements and read all safety warnings. By knowing both machines thoroughly, how it operates and by doing the prescribed maintenance steps, you can expect relatively trouble-free operation for years to come.

#### TOW VEHICLE

You will need a heavy duty vehicle with 4 wheel brakes and 3-point hitch. 3-point is standard on Aer-8 Aerifier.

**Transport Frame Assembly** requires a clevis hitch and a  $\frac{3}{4}$  diameter by 4" pin with some type of lock. Tow vehicle must be capable of 825 lb tongue weight.

#### DAILY CHECKLIST

1. Check engine oil level in tow vehicle. Add as needed. **DO NOT OVERFILL.**
2. Check aerifier for loose or missing nuts, bolts, screws, etc., and tighten or replace as needed..
3. Check that all tines are in good condition.
4. Grease bearings daily after each use.

If transport frame assembly is installed:

5. Check hydraulic hoses for any leaks or loose connections.
6. Check tire pressure. 20 psi (1.4 bar)
7. Check electrical system for loose connections or frayed wiring, including battery cables. Replace any faulty equipment or tighten if loose.

#### OPERATION SAFETY

1. Before operation check to see that reel is rotating properly.
2. 3-point lift arms of tow vehicle must **not be** locked, but in floating position.
3. Always lift tines completely out of the soil before making sharp turns.
4. Do not aerate during extended periods of dry periods without irrigation.
5. When not in use, remove the jack pin and extend the legs to maximum extension, reinsert the jack pin and secure with a clip. Always use jack stands for safe storage.

#### LUBRICATION

Use No. 2 General Purpose Lithium Base Grease and lubricate **DAILY.** The Aerifier has 2 grease fittings, one on each pillow block on each side of the reel. When inserting grease, be careful not to ruin the seal, if this happens, replace the seal at once. Be sure to wipe grease fitting clean before injecting grease. Give only one or two pumps of grease at each lubrication.

## WHEEL MOUNTING PROCEDURE

1. Set park brake on tow vehicle. Turn machine off and remove key.
2. Block one of the other wheels.
3. Loosen nuts slightly on wheel to be removed.
4. Jack up machine being careful not to damage underside of machine.
5. Remove nuts, remove wheel.
5. Place new wheel on hub lining up bolt holes.
6. Torque nuts to 64-74 ft/lb (87-100Nm) using a cross pattern. Retorque after first 10 hours and every 200 hours thereafter.
7. Lower machine to ground and remove blocks and jack.

## TIRE PRESSURE

Caution must be used when inflating a low tire to recommended pressure. Over inflating can cause tires to explode. Tires on the machine should be 20 psi (1.4 bar). Improper inflation will reduce tire life considerably.

## SERVICE INTERVALS

### Before each Use:

Lubricate all bearings on reel. Use No. 2 General Purpose Lithium Base Grease.

Check tow vehicle fluid levels.

Check fluid level in power unit. Use Universal Trans-Draulic Oil.

### After Each Use:

Check all tines for any cracks or breakage..

Inspect hydraulic system for leaks or damage.

Check for loose or missing hardware.

### After 10 hours:

Check tines for wear.

Retorque tine bolts to 80ft lbs.

Lubricate all grease fittings

### After 50 hours:

Check wheel lug nuts torque to 64-74 ft/lb (87-100Nm).

Inspect tires - Check air pressure 20 psi

Retorque tine bolts to 80ft lbs.

### After 125 hours:

Lubricate wheel bearings.

### After 250 Hours:

Drain oil and fill power unit with approximately 1.25 gallons (4,73 l) Universal Trans-Draulic Oil.

Tire - Torque nuts to 64-74 ft/lb (87-100Nm) using a cross pattern.



## MAINTENANCE

### HILLSIDE OPERATION

Do NOT stop or start suddenly on any slope. Be especially cautious when changing direction. Do NOT operate on slopes greater than 20°.

### BATTERY

Batteries normally produce explosive gases which can cause personal injury. Do not allow flames, sparks or any ignited object to come near the battery. When charging or working near battery, always shield your eyes and always provide proper ventilation.

Battery cable should be disconnected before using "Fast Charge".

Charge battery at 15 amps for 10 minutes or 7 amps for 30 minutes. Do not exceed the recommended charging rate. If electrolyte starts boiling over, decrease charging.

Always remove grounded (-) battery clamp first and replace it last. Avoid hazards by:

1. Filling batteries in well-ventilated areas.
2. Wear eye protection and rubber gloves.
3. Avoid breathing fumes when electrolyte is added.
4. Avoid spilling or dripping electrolyte.



**WARNING**

**Battery Electrolyte is an acidic solution and should be handled with care. If electrolyte is splashed on any part of your body, flush all contact areas immediately with liberal amounts of water. Get medical attention immediately.**

1. Before storing clean machine thoroughly.
2. Check bolts and nuts, tighten as necessary.
3. Make all repairs that are needed and remove any debris.
4. Store in a clean and dry area.
5. Make sure reel is on level ground.
6. Lower all 4 jack stands if Transport Assembly is not installed. Secure pins.
7. If transport Assembly is installed lower front jack stands and the trailer hitch on the tongue. Secure pins.
8. If roller is installed, it will act as the rear jacks. Lower roller to the lowest position then lower front jacks. Secure pins.
8. Only after Aer-8 is securely placed on a level surface should you remove from the tow vehicle.

# AER8-001 HYDRAULIC TRANSPORT FRAME

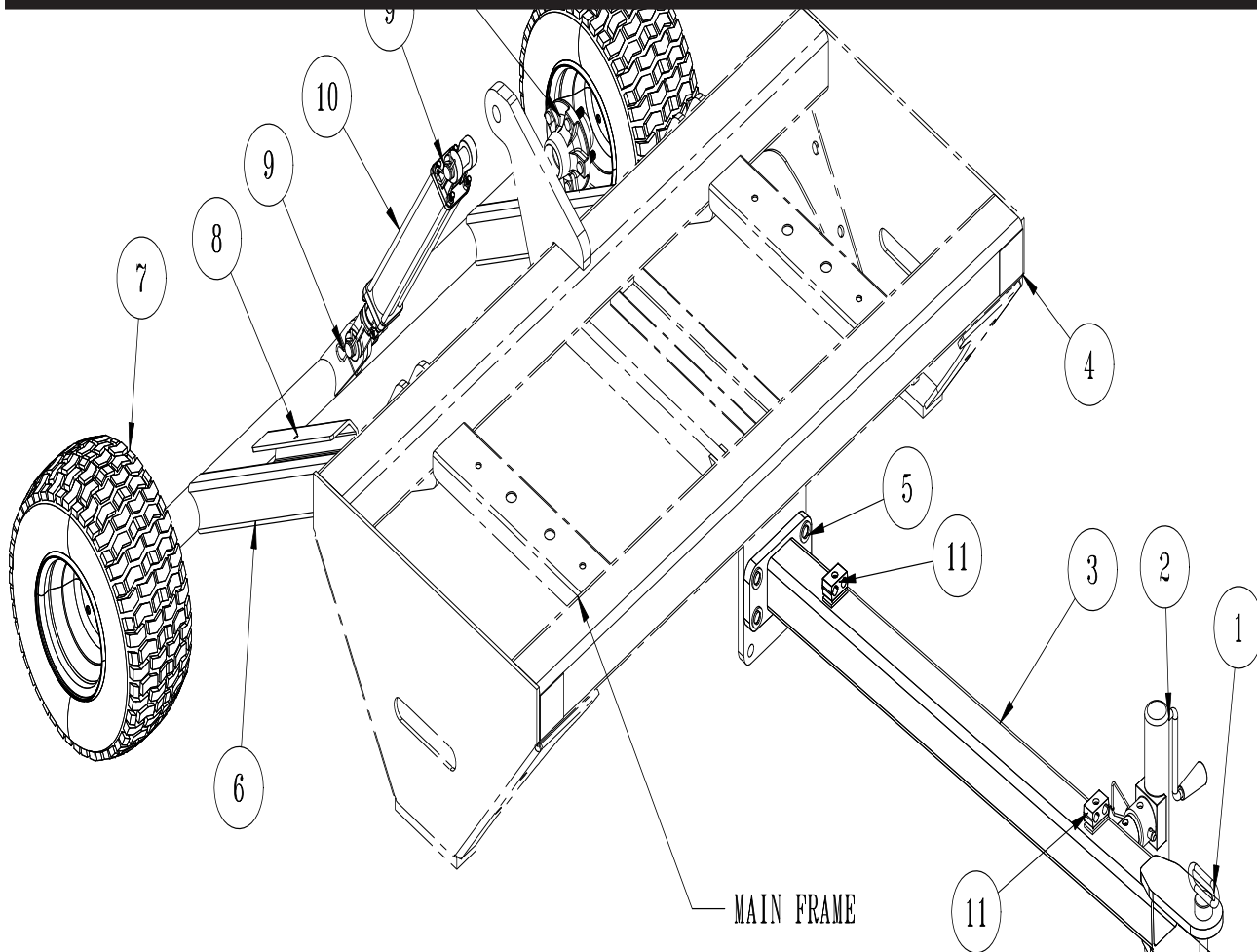

# AER8-001 HYDRAULIC TRANSPORT FRAME

| REF# | PART#        | DESCRIPTION                 | QUANTITY |
|------|--------------|-----------------------------|----------|
| 1    | 74-257       | Hitch Pin                   | 1        |
| 2    | 78-240       | Trailer Jack                | 1        |
| 3    | 74-241       | Tongue                      | 1        |
| 4    | 74-156       | Decal, reflector            | 4        |
| 5    | HB-34-10-300 | Bolt 3/4 -10 x 3            | 4        |
|      | HMB-34-10    | Machine Bushing 3/4 x 10GA  | 4        |
|      | HNTL-34-10   | Lock Nut 3/4-10             | 4        |
| 6    | 74-244       | Axle                        | 1        |
| 7    | 60-130       | Tire and Wheel              | 2        |
|      | 60-130-01    | Tire, 18 x 9.5 x 8          | 2        |
|      | 60-130-02    | Wheel                       | 2        |
| 8    | 74-254       | Cylinder Stop               | 1        |
|      | HB-38-16-275 | Bolt 3/8 -16 x 2-3/4        | 1        |
|      | HNW-38-16    | Wing nut 3/8-16             | 1        |
| 9    | HCP-100-400  | Clevis pin 1 x 4            | 2        |
|      | HP-316-200   | Cotter pin 3/16 x 2         | 2        |
| 10   | 78-225       | Hydraulic Cylinder          | 1        |
|      | 18-168       | 3/8 Straight Thread Elbow   | 2        |
| 11   | 13-652       | Hose Clamp (part of tongue) | 2        |

Must use AER8-002 Electric/Hydraulic Lift or AER8-003 Hydraulic Hose kit

**AER8-003 HYDRAULIC HOSE KIT**

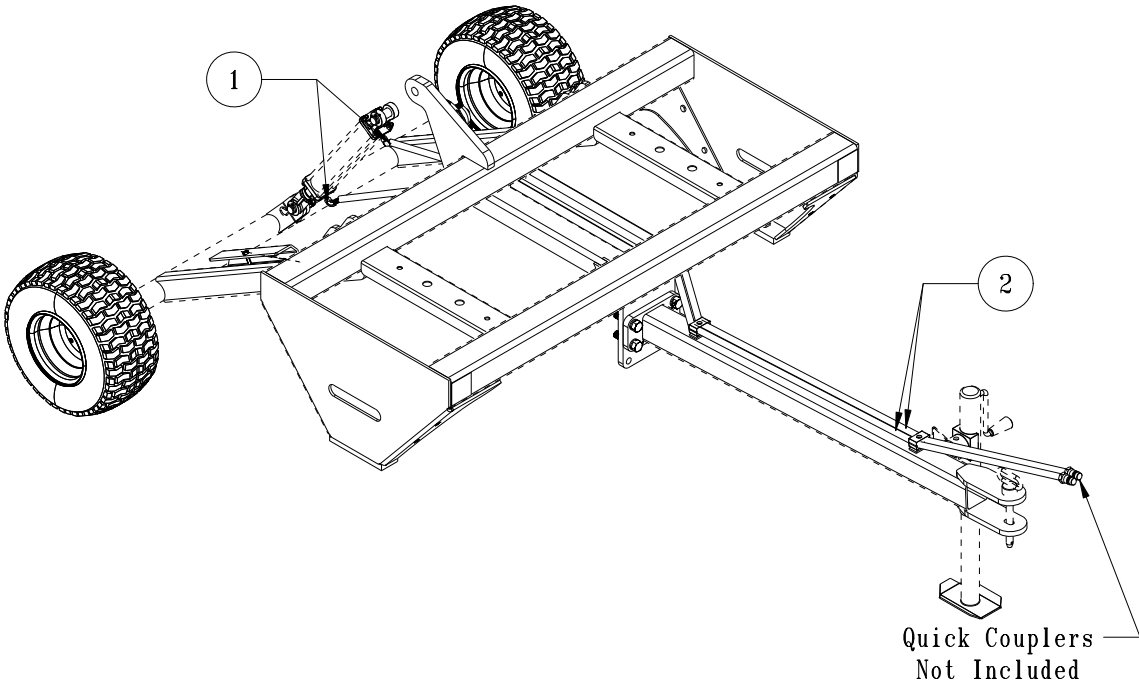

**AER8-003 HYDRAULIC HOSE KIT**

| REF# | PART#  | DESCRIPTION                                    | QUANTITY |
|------|--------|--|----------|
| 1    | 18-168 | 3/8 Straight Thread Elbow (come with AER8-001) | 2        |
| 2    | 74-246 | Hydraulic Hose - 22'                           | 2        |

**Quick Couplers are not included.  
AER-001 Hydraulic Transport Kit Required.**

Parts

# AER8-002 ELECTRIC/HYDRAULIC LIFT SYSTEM

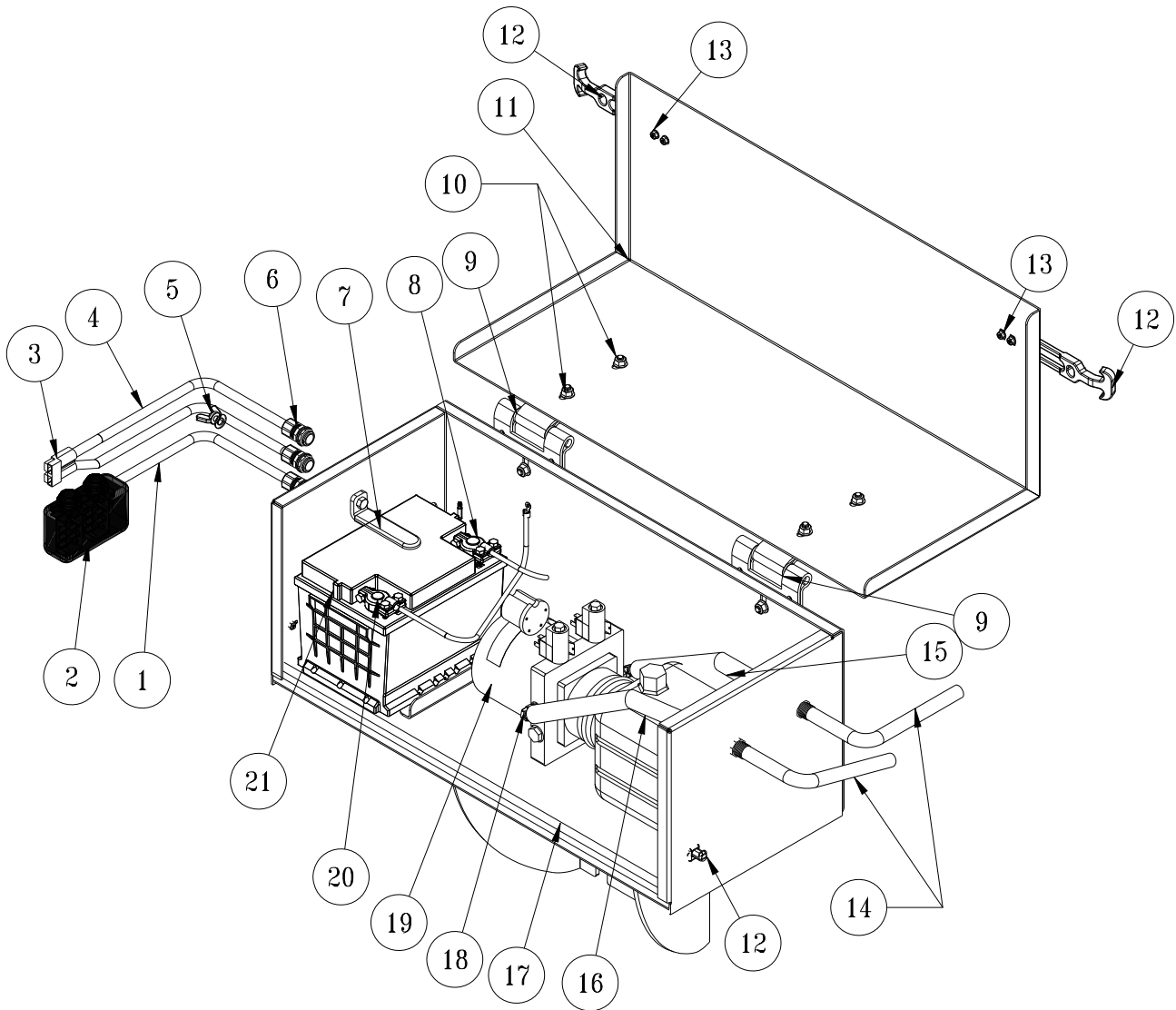

Parts



# AER8-002 ELECTRIC/HYDRAULIC LIFT SYSTEM

| REF# | PART#         | DESCRIPTION                              | QUANTITY |
|------|---------------|--|----------|
| 1    | 74-274        | 15' Parallel Cable System                | 1        |
| 2    | 18-446-01     | Remote Switch                            | 1        |
| 3    | 74-271        | Multi-Pole Power Connector               | 1        |
| 4    | 74-275        | 8' Parallel Cable System                 | 1        |
| 5    | HNW-38-16     | Wing Nut $\frac{3}{8}$ - 16              | 1        |
|      | HW-38         | Washer $\frac{3}{8}$                     | 1        |
|      | HWL-38        | Lock Washer $\frac{3}{8}$                | 1        |
| 6    | 18-445        | Cord Connectors                          | 1        |
| 7    | 74-234        | Battery Hold Down                        | 1        |
|      | 15-020        | Grip                                     | 1        |
|      | HB-38-16-100  | Bolt $\frac{3}{8}$ - 16 x 1              | 1        |
| 8    | 22-055        | Battery Cable Red                        | 1        |
| 9    | 74-231        | Hinge                                    | 2        |
| 10   | HB-516-18-075 | Bolt $\frac{5}{16}$ - 18 x $\frac{3}{4}$ | 6        |
|      | HNFL-516-18   | Flange Lock Nut $\frac{5}{16}$ - 18      | 6        |
| 11   | 74-248        | Motor Box Cover                          | 1        |
|      | 8947-31       | Trim Seal 31"                            | 2        |
|      | 25-277        | Decal, Warning                           | 1        |
|      | 25-373        | Decal, 7" Smithco Star                   | 1        |
| 12   | 15-437        | Latch                                    | 2        |
| 13   | HSM-10-32-112 | Machine Screw #10-32 x 1 $\frac{1}{8}$   | 6        |
|      | HNFL-10-32    | Flange Lock Nut # 10 - 32                | 6        |
| 14   | 74-232        | Hose - 72"                               | 2        |
| 15   | 74-230        | Hose - 17"                               | 1        |
| 16   | 74-229        | Hose - 16"                               | 1        |
|      | 8947-74       | Trim Seal 74"                            | 1        |
| 17   | 74-233        | Motor Box                                | 1        |
| 18   | 18-168        | $\frac{3}{8}$ Straight Thread Elbow      | 2        |
| 19   | 18-446        | Power Unit                               | 1        |
| 20   | 76-327        | Battery Cable - Black                    | 1        |
| 21   | Not Included  | Battery - Automotive type 24F-12 Volt    | 1        |

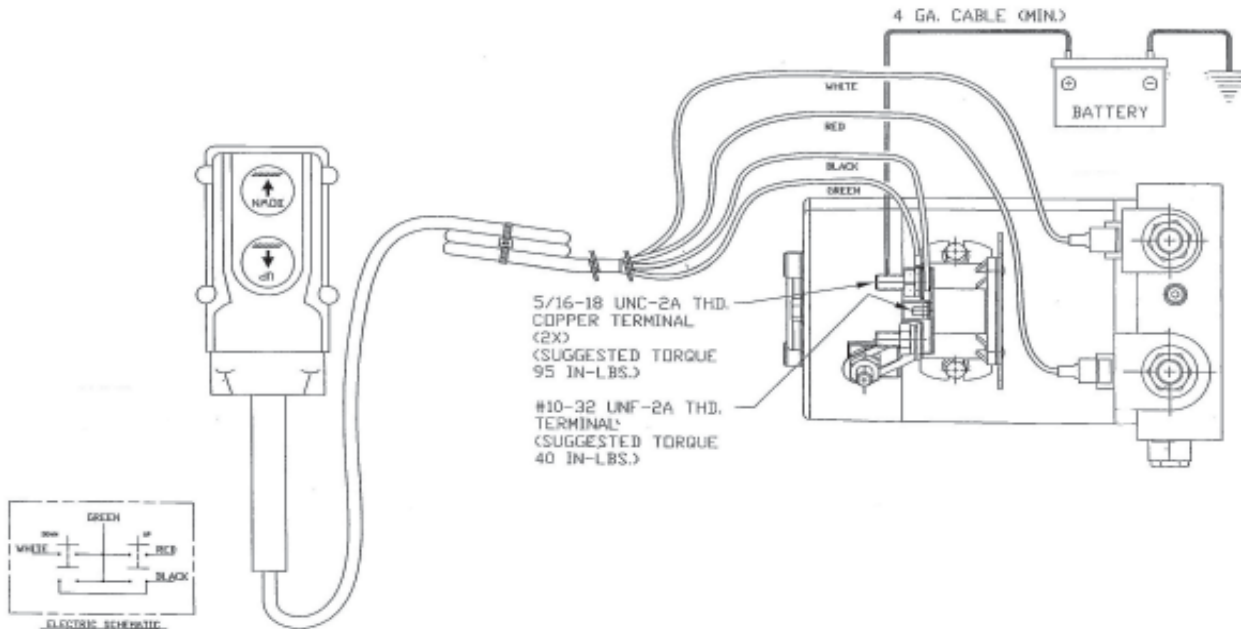

## AER 8 Charging Harness

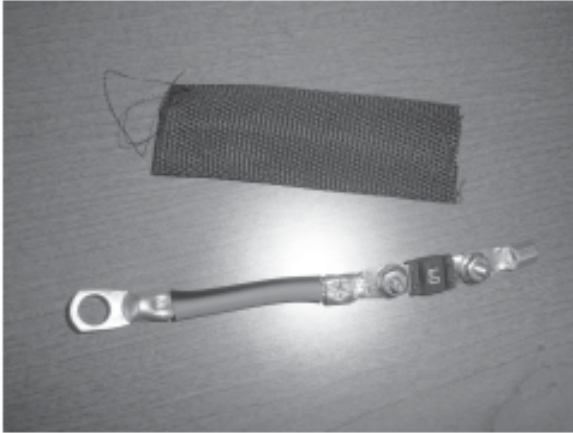

Use a 3" piece of red/black power wire. Add 2 standard eyelets to each end. Place a MIDI High AMP Fuse 60A on one end, then add another eyelet.

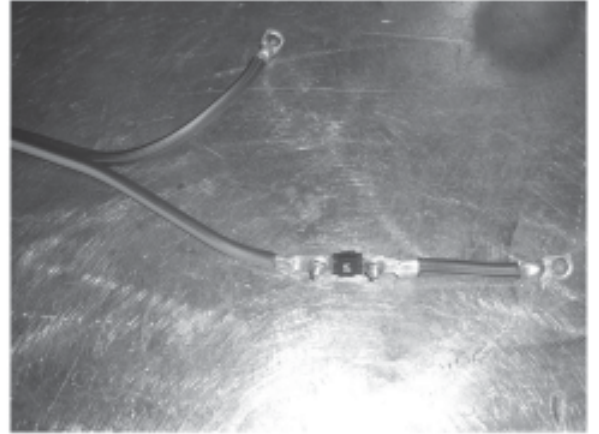

Hook the "open" eyelet onto the red/ black part of the 8' Parallel cable. Add another eyelet to the black part of the Parallel cable.

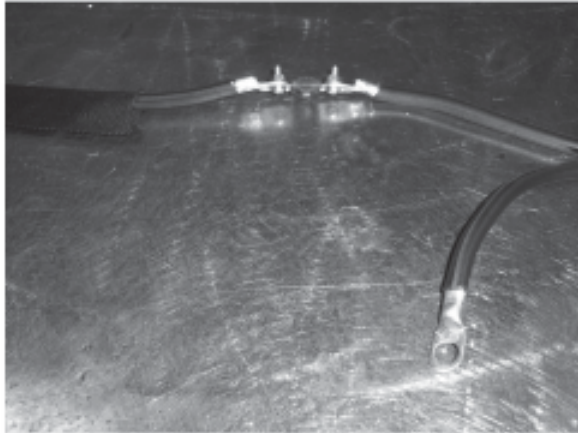

Slide a 5" piece of heat shrink over the fuse connection.

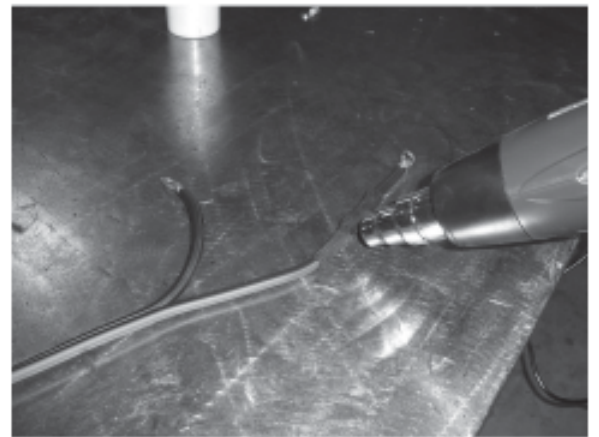

Using a heat gun, heat the heat shrink on.

1. Route charging wire from hitch to battery. Leave enough wire at the hitch so it won't pull while turning.
2. Zip tie wire out of the way of moving parts, pinch points and hot areas.
3. Cut cable to length and crimp ring terminal to black wire and fuse link assembly to red/black wire.
4. Cover with heat shrink.
5. Connect black wire to Negative (-) battery terminal and red/black wire to positive (+) battery terminal.

## 3-POINT HITCH DRAWING

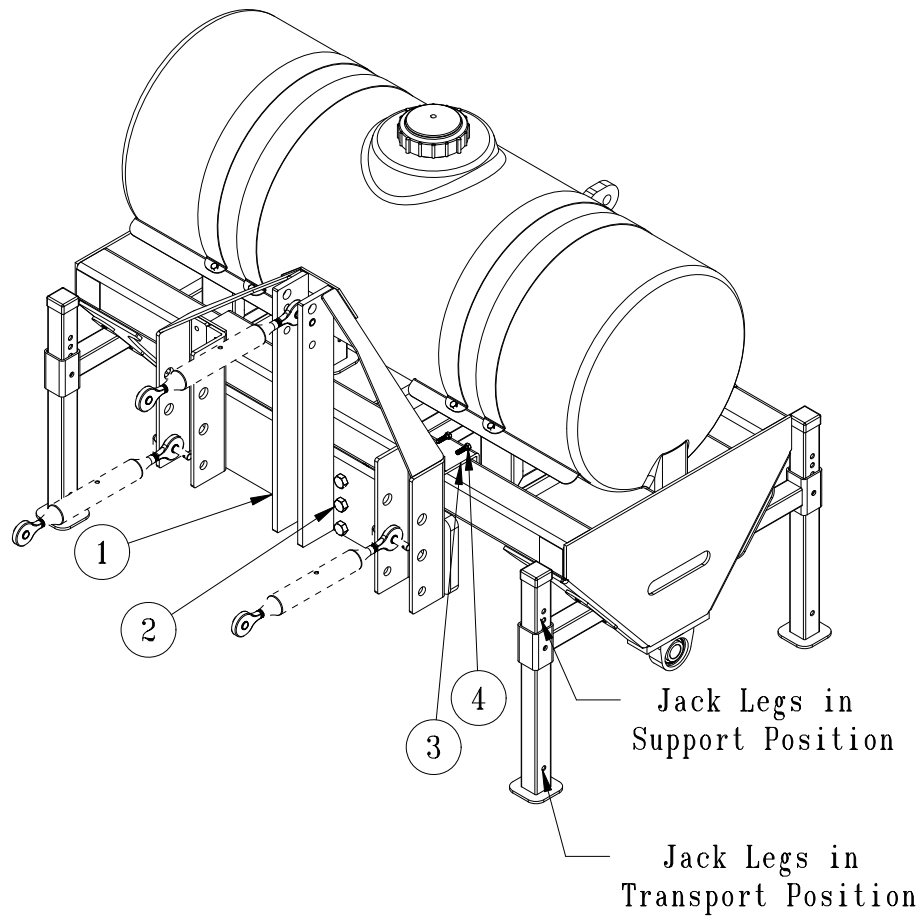

Parts

## 3-POINT HITCH PARTS LIST

| REF# | PART#        | DESCRIPTION                              | QUANTITY |
|------|--------------|--|----------|
| 1    | 74-279       | 3-Point Hitch Frame                      | 1        |
| 2    | HB-34-10-300 | Bolt $\frac{3}{4}$ - 10 x 3              | 6        |
|      | HMB-34-10    | Machine Bushing $\frac{3}{4}$ x 10GA     | 6        |
|      | HNTL-34-10   | Lock Nut $\frac{3}{4}$ - 10              | 6        |
| 3    | 74-282       | Mount Brackets                           | 2        |
| 4    | HB-38-16-125 | Bolt $\frac{3}{8}$ - 16 x $1\frac{1}{4}$ | 4        |
|      | HNTL-38-16   | Lock Nut $\frac{3}{8}$ - 16              | 4        |

# AER-8 "TURFQUAKE" 5" SPACING DRAWING

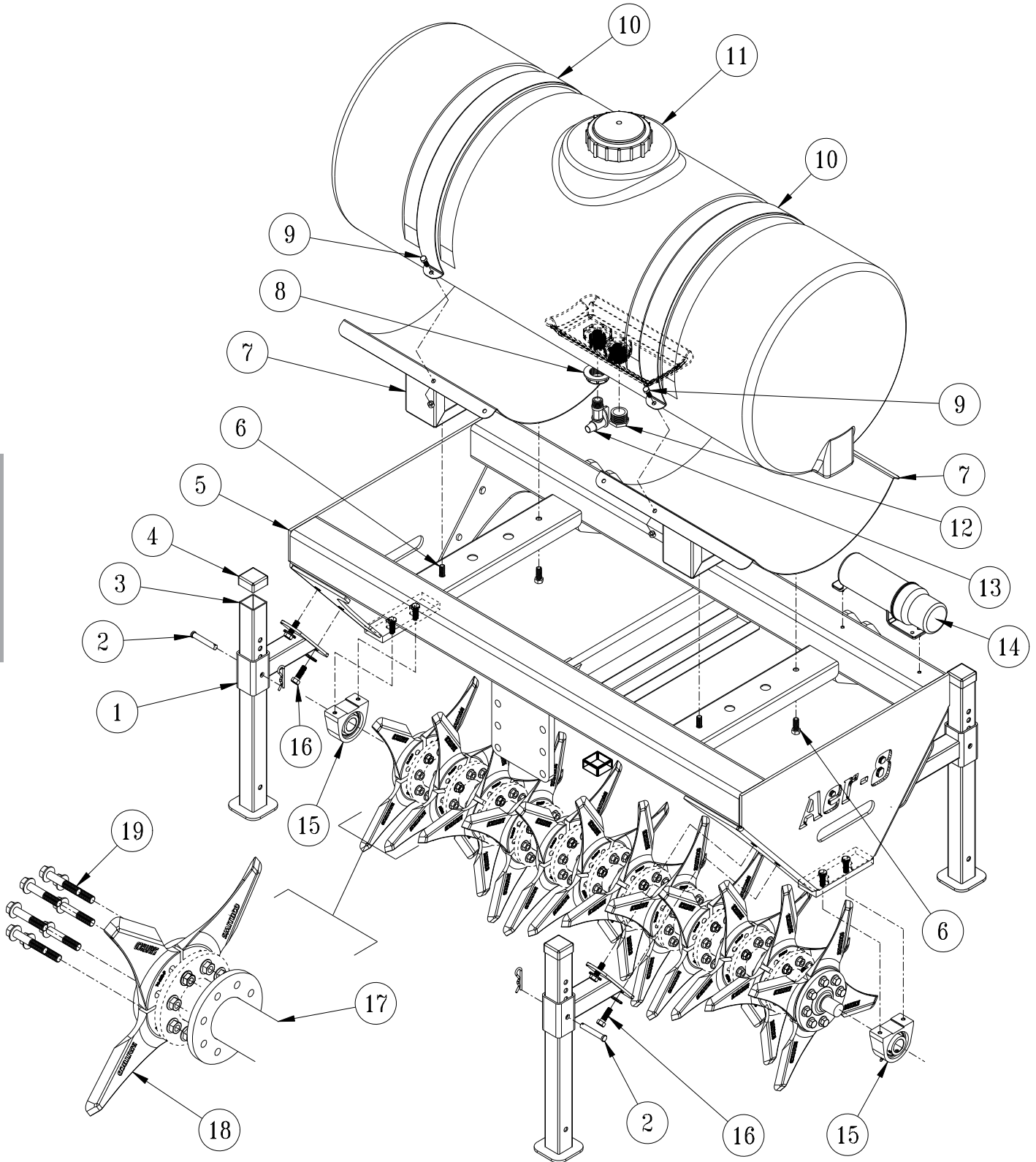

## AER-8 "TURF QUAKE" 5" SPACING PARTS LIST

| REF#                | PART#        | DESCRIPTION                     | QUANTITY |
|---------------------|--------------|---------------------------------|----------|
| 1                   | 74-228       | Kick Stand Mount                | 4        |
| 2                   | HCP-12-300   | Clevis Pin, 1/2 x 3             | 4        |
|                     | HHP-177      | Bridge Pin, .177 x 3 3/4        | 4        |
| 3                   | 74-227       | Kickstand Leg                   | 4        |
| 4                   | 16-557       | Square Cap                      | 4        |
| 5                   | 74-245       | Mainframe, 60"                  | 1        |
|                     | 74-280       | Mainframe, 78"                  | 1        |
|                     | 74-157       | Decal, Aer-8                    | 2        |
| 6                   | HB-12-13-125 | Hex Bolt, 1/2 - 13 x 1 1/4      | 4        |
|                     | HNFL-12-13   | Flange Lock Nut, 1/2 - 13       | 4        |
| 7                   | 74-243       | Tank Carrier                    | 2        |
| 8                   | 16-150       | Double Thread Fitting           | 1        |
| 9                   | HB-38-16-275 | Hex Bolt, 3/8 - 13 x 2 1/4      | 4        |
|                     | HNTL-38-16   | Lock Nut, 3/8 - 16              | 4        |
| 10                  | 74-242       | Tank Strap                      | 2        |
| 11                  | 74-211       | 100 Gal. Tank                   | 1        |
| 12                  | 10-389       | Plug, 1 1/4                     | 1        |
| 13                  | 16-960       | Spigot                          | 1        |
| 14                  | 74-213       | Bearing                         | 2        |
|                     | HB-12-13-175 | Hex Bolt, 1/2 - 13 x 1 3/4      | 4        |
|                     | HW-12        | Flat Washer, 1/2                | 4        |
|                     | HWL-12       | Lock Washer, 1/2                | 4        |
| 15                  | HB-12-13-125 | Hex Bolt, 1/2 - 13 x 1 1/4      | 8        |
|                     | HNFL-12-13   | Flange Lock Nut, 1/2 - 13       | 8        |
| <b>60" AER8-601</b> |              |                                 |          |
| 16*                 | 74-277       | 60" Knife Reel, 5" Spacing      | 1        |
| 17*                 | 74-259       | "Turf Quake" Fracture Tine      | 48       |
| 18*                 | 74-266       | UNF Flange Bolt                 | 96       |
|                     | 74-267       | UNF Flange Nut                  | 96       |
| *                   | AER8-60R601  | 60" Turf Quake 5" Reel Assembly |          |
| <b>78" AER8-781</b> |              |                                 |          |
| 16**                | 74-288       | 78" Knife Reel, 5" Spacing      | 1        |
| 17**                | 74-259       | "Turf Quake" Fracture Tine      | 60       |
| 18**                | 74-266       | UNF Flange Bolt                 | 120      |
|                     | 74-267       | UNF Flange Nut                  | 120      |
| **                  | AER8-78R781  | 78" Turf Quake 5" Reel Assembly |          |

# AER-8 "TURF QUAKE" 7½" SPACING DRAWING

Parts

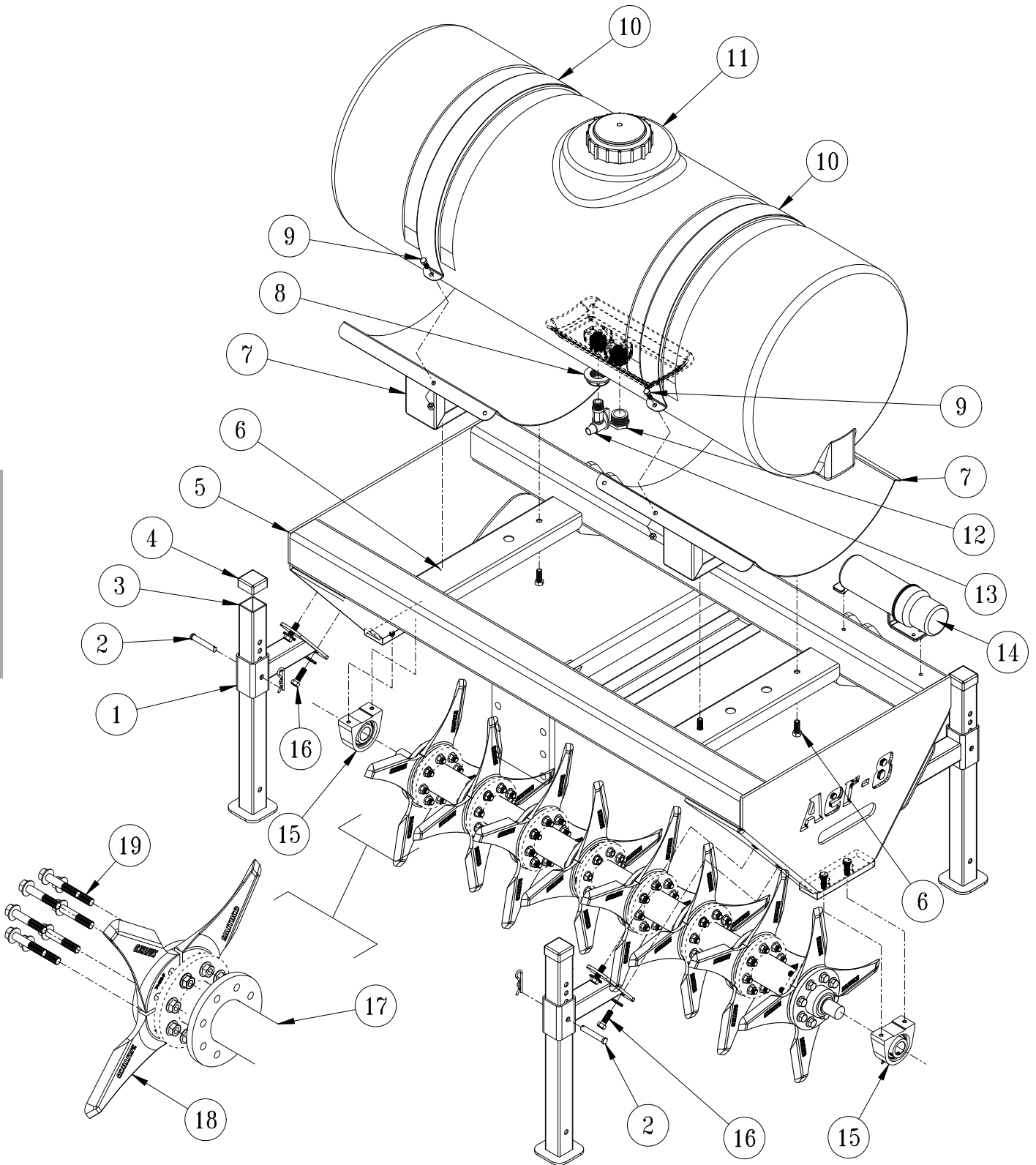

## AER-8 "TURF QUAKE" 7½" SPACING PARTS LIST

| REF#                | PART#        | DESCRIPTION                       | QUANTITY |
|---------------------|--------------|-----------------------------------|----------|
| 1                   | 74-228       | Kickstand Mount                   | 4        |
| 2                   | HCP-12-300   | Clevis Pin, ½ x 3                 | 4        |
|                     | HHP-177      | Bridge Pin, .177 x 3¾             | 4        |
| 3                   | 74-227       | Kickstand Leg                     | 4        |
| 4                   | 16-557       | Square Cap                        | 4        |
| 5                   | 74-245       | Mainframe, 60"                    | 1        |
|                     | 74-280       | Mainframe, 78"                    | 1        |
|                     | 74-157       | Decal, Aer-8                      | 2        |
| 6                   | HB-12-13-125 | Hex Bolt, ½ - 13 x 1¼             | 4        |
|                     | HNFL-12-13   | Flange Lock Nut, ½ - 13           | 4        |
| 7                   | 74-243       | Tank Carrier                      | 2        |
| 8                   | 16-150       | Double Thread Fitting             | 1        |
| 9                   | HB-38-16-275 | Hex Bolt, ¾ - 13 x 2¾             | 4        |
|                     | HNTL-38-16   | Lock Nut, ¾ - 16                  | 4        |
| 10                  | 74-242       | Tank Strap                        | 2        |
| 11                  | 74-211       | 100 Gal. Tank                     | 1        |
| 12                  | 10-389       | Plug, 1¼                          | 1        |
| 13                  | 16-960       | Spigot                            | 1        |
| 14                  | 74-213       | Bearing                           | 2        |
|                     | HB-12-13-175 | Hex Bolt, ½ - 13 x 1¾             | 4        |
|                     | HW-12        | Flat Washer, ½                    | 4        |
|                     | HWL-12       | Lock Washer, ½                    | 4        |
| 15                  | HB-12-13-125 | Hex Bolt, ½ - 13 x 1¼             | 8        |
|                     | HNFL-12-13   | Flange Lock Nut, ½ - 13           | 8        |
| <b>60" AER8-602</b> |              |                                   |          |
| 16*                 | 74-263       | 60" Knife Reel, 7½" Spacing       | 1        |
| 17*                 | 74-259       | "Turf Quake" Fracture Tine        | 32       |
| 18*                 | 74-266       | UNF Flange Bolt                   | 64       |
|                     | 74-267       | UNF Flange Nut                    | 64       |
| *                   | AER8-60R602  | 60" Turf Quake 7.5" Reel Assembly |          |
| <b>78" AER8-782</b> |              |                                   |          |
| 16**                | 74-289       | 78" Knife Reel, 7½" Spacing       | 1        |
| 17**                | 74-259       | "Turf Quake" Fracture Tine        | 40       |
| 18**                | 74-266       | UNF Flange Bolt                   | 80       |
|                     | 74-267       | UNF Flange Nut                    | 80       |
| **                  | AER8-78R782  | 78" Turf Quake 7.5" Reel Assembly |          |





## AER-8 "ALL STAR" 5" SPACING PARTS LIST

| REF#                | PART#        | DESCRIPTION                   | QUANTITY |
|---------------------|--------------|-------------------------------|----------|
| 1                   | 74-228       | Kickstand Mount               | 4        |
| 2                   | HCP-12-300   | Clevis Pin, 1/2 x 3           | 4        |
|                     | HHP-177      | Bridge Pin, .177 x 3 3/4      | 4        |
| 3                   | 74-227       | Kickstand Leg                 | 4        |
| 4                   | 16-557       | Square Cap                    | 4        |
| 5                   | 74-245       | Mainframe, 60"                | 1        |
|                     | 74-280       | Mainframe, 78"                | 1        |
|                     | 74-157       | Decal, Aer-8                  | 2        |
| 6                   | HB-12-13-125 | Hex Bolt, 1/2 - 13 x 1 1/4    | 4        |
|                     | HNFL-12-13   | Flange Lock Nut, 1/2 - 13     | 4        |
| 7                   | 74-243       | Tank Carrier                  | 2        |
| 8                   | 16-150       | Double Thread Fitting         | 1        |
| 9                   | HB-38-16-275 | Hex Bolt, 3/8 - 13 x 2 1/4    | 4        |
|                     | HNTL-38-16   | Lock Nut, 3/8 - 16            | 4        |
| 10                  | 74-242       | Tank Strap                    | 2        |
| 11                  | 74-211       | 100 Gal. Tank                 | 1        |
| 12                  | 10-389       | Plug, 1 1/4                   | 1        |
| 13                  | 16-960       | Spigot                        | 1        |
| 14                  | 74-213       | Bearing                       | 2        |
|                     | HB-12-13-175 | Hex Bolt, 1/2 - 13 x 1 3/4    | 4        |
|                     | HW-12        | Flat Washer, 1/2              | 4        |
|                     | HWL-12       | Lock Washer, 1/2              | 4        |
| 15                  | HB-12-13-125 | Hex Bolt, 1/2 - 13 x 1 1/4    | 8        |
|                     | HNFL-12-13   | Flange Lock Nut, 1/2 - 13     | 8        |
| <b>60" AER8-603</b> |              |                               |          |
| 16*                 | 74-277       | 60" Knife Reel, 5" Spacing    | 1        |
| 17*                 | 74-258       | "All Star" Sport Tine         | 48       |
| 18*                 | 74-266       | UNF Flange Bolt               | 96       |
|                     | 74-267       | UNF Flange Nut                | 96       |
| *                   | AER8-60R603  | 60" All Star 5" Reel Assembly |          |
| <b>78" AER8-783</b> |              |                               |          |
| 16**                | 74-288       | 78" Knife Reel, 5" Spacing    | 1        |
| 17**                | 74-258       | "All Star" Sport Tine         | 60       |
| 18**                | 74-266       | UNF Flange Bolt               | 120      |
|                     | 74-267       | UNF Flange Nut                | 120      |
| **                  | AER8-78R783  | 78" All Star 5" Reel Assembly |          |



# AER-8 "ALL STAR" 7½" SPACING DRAWING

Parts

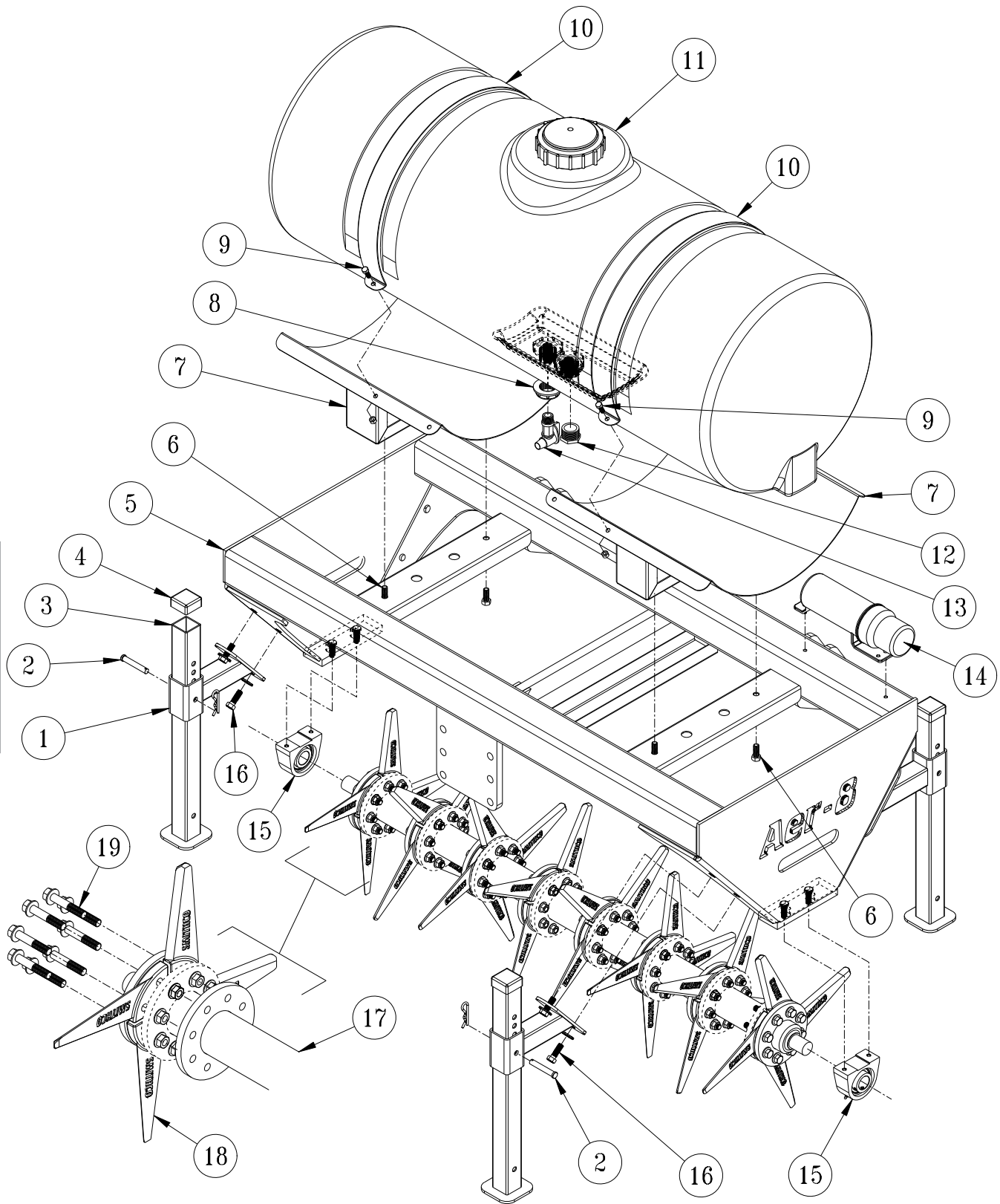

## AER-8 "ALL STAR" 7½" SPACING PARTS LIST

| REF#                | PART#        | DESCRIPTION                     | QUANTITY |
|---------------------|--------------|---------------------------------|----------|
| 1                   | 74-228       | Kickstand Mount                 | 4        |
| 2                   | HCP-12-300   | Clevis Pin, ½ x 3               | 4        |
|                     | HHP-177      | Bridge Pin, .177 x 3¾           | 4        |
| 3                   | 74-227       | Kickstand Leg                   | 4        |
| 4                   | 16-557       | Square Cap                      | 4        |
| 5                   | 74-245       | Mainframe, 60"                  | 1        |
|                     | 74-280       | Mainframe, 78"                  | 1        |
|                     | 74-157       | Decal, Aer-8                    | 2        |
| 6                   | HB-12-13-125 | Hex Bolt, ½ - 13 x 1¼           | 4        |
|                     | HNFL-12-13   | Flange Lock Nut, ½ - 13         | 4        |
| 7                   | 74-243       | Tank Carrier                    | 2        |
| 8                   | 16-150       | Double Thread Fitting           | 1        |
| 9                   | HB-38-16-275 | Hex Bolt, ¾ - 13 x 2¾           | 4        |
|                     | HNTL-38-16   | Lock Nut, ¾ - 16                | 4        |
| 10                  | 74-242       | Tank Strap                      | 2        |
| 11                  | 74-211       | 100 Gal. Tank                   | 1        |
| 12                  | 10-389       | Plug, 1¼                        | 1        |
| 13                  | 16-960       | Spigot                          | 1        |
| 14                  | 74-213       | Bearing                         | 2        |
|                     | HB-12-13-175 | Hex Bolt, ½ - 13 x 1¾           | 4        |
|                     | HW-12        | Flat Washer, ½                  | 4        |
|                     | HWL-12       | Lock Washer, ½                  | 4        |
| 15                  | HB-12-13-125 | Hex Bolt, ½ - 13 x 1¼           | 8        |
|                     | HNFL-12-13   | Flange Lock Nut, ½ - 13         | 8        |
| <b>60" AER8-604</b> |              |                                 |          |
| 16*                 | 74-277       | 60" Knife Reel, 5" Spacing      | 1        |
| 17*                 | 74-258       | "All Star" Sport Tine           | 32       |
| 18*                 | 74-266       | UNF Flange Bolt                 | 64       |
|                     | 74-267       | UNF Flange Nut                  | 64       |
| *                   | AER8-60R604  | 60" All Star 7.5" Reel Assembly |          |
| <b>78" AER8-784</b> |              |                                 |          |
| 16**                | 74-289       | 78" Knife Reel, 5" Spacing      | 1        |
| 17**                | 74-258       | "All Star" Sport Tine           | 40       |
| 18**                | 74-266       | UNF Flange Bolt                 | 80       |
|                     | 74-267       | UNF Flange Nut                  | 80       |
| **                  | AER8-78R784  | 78" All Star 7.5" Reel Assembly |          |

# AER-8 "AERFINE" 3" SPACING DRAWING

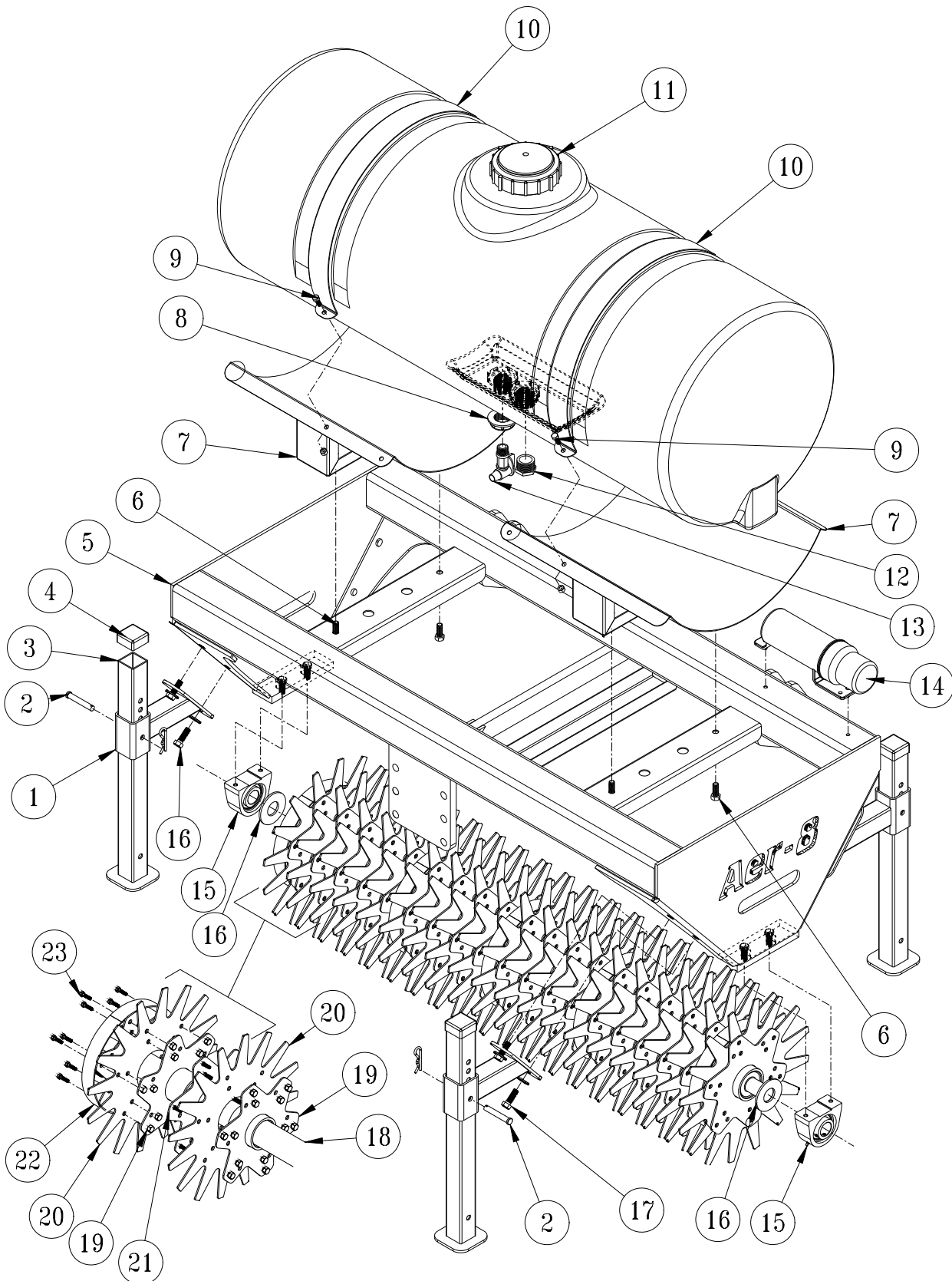

Parts

## AER-8 "AERFINE" 3" SPACING PARTS LIST

| REF#                | PART#        | DESCRIPTION                  | QUANTITY |
|---------------------|--------------|------------------------------|----------|
| 1                   | 74-228       | Kickstand Mount              | 4        |
| 2                   | HCP-12-300   | Clevis Pin, 1/2 x 3          | 4        |
|                     | HHP-177      | Bridge Pin, .177 x 3 3/4     | 4        |
| 3                   | 74-227       | Kickstand Leg                | 4        |
| 4                   | 16-557       | Square Cap                   | 4        |
| 5                   | 74-245       | Mainframe, 60"               | 1        |
|                     | 74-280       | Mainframe, 78"               | 1        |
|                     | 74-157       | Decal, Aer-8                 | 2        |
| 6                   | HB-12-13-125 | Hex Bolt, 1/2 - 13 x 1 1/4   | 4        |
|                     | HNFL-12-13   | Flange Lock Nut, 1/2 - 13    | 4        |
| 7                   | 74-243       | Tank Carrier                 | 2        |
| 8                   | 16-150       | Double Thread Fitting        | 1        |
| 9                   | HB-38-16-275 | Hex Bolt, 3/8 - 16 x 2 1/4   | 4        |
|                     | HNTL-38-16   | Lock Nut, 3/8 - 16           | 4        |
| 10                  | 74-242       | Tank Strap                   | 2        |
| 11                  | 74-211       | 100 Gal. Tank                | 1        |
| 12                  | 10-389       | Plug, 1 1/4                  | 1        |
| 13                  | 16-960       | Spigot                       | 1        |
| 14                  | 74-213       | Bearing                      | 2        |
|                     | HB-12-13-175 | Hex Bolt, 1/2 - 13 x 1 3/4   | 4        |
|                     | HW-12        | Flat Washer, 1/2             | 4        |
|                     | HWL-12       | Lock Washer, 1/2             | 4        |
| 15                  | HB-12-13-125 | Hex Bolt, 1/2 - 13 x 1 1/4   | 8        |
|                     | HNFL-12-13   | Flange Lock Nut, 1/2 - 13    | 8        |
| 22                  | 74-215       | Shaft Flange                 | 2        |
| <b>60" AER8-605</b> |              |                              |          |
| 16*                 | 74-239       | 60" Core/Fine Shaft          | 1        |
| 17*                 | 74-251       | Core Tine Wheel              | 19       |
| 18*                 | 74-265       | "Aerfine" Ultra-Fine Blade   | 19       |
| 19*                 | 74-264       | Plate                        | 14       |
| 20*                 | 74-269       | Depth Spacer                 | 5        |
| 21*                 | HB-38-16-100 | Bolt, 3/8 - 16 x 1           | 228      |
|                     | HNFL-38-16   | Flange Lock Nut, 3/8 - 16    | 228      |
| *                   | AER8-60R605  | 60" Aerfine 3" Reel Assembly |          |
| <b>78" AER8-785</b> |              |                              |          |
| 16**                | 74-262       | 78" Core/Fine Shaft          | 1        |
| 17**                | 74-251       | Core Tine Wheel              | 25       |
| 18**                | 74-265       | "Aerfine" Ultra-Fine Blade   | 25       |
| 19**                | 74-264       | Plate                        | 19       |
| 20**                | 74-269       | Depth Spacer                 | 6        |
| 21**                | HB-38-16-100 | Bolt, 3/8 - 16 x 1           | 300      |
|                     | HNFL-38-16   | Flange Lock Nut, 3/8 - 16    | 300      |
| **                  | AER8-78R785  | 78" Aerfine 3" Reel Assembly |          |

# AER-8 "AERFINE" 5" SPACING DRAWING

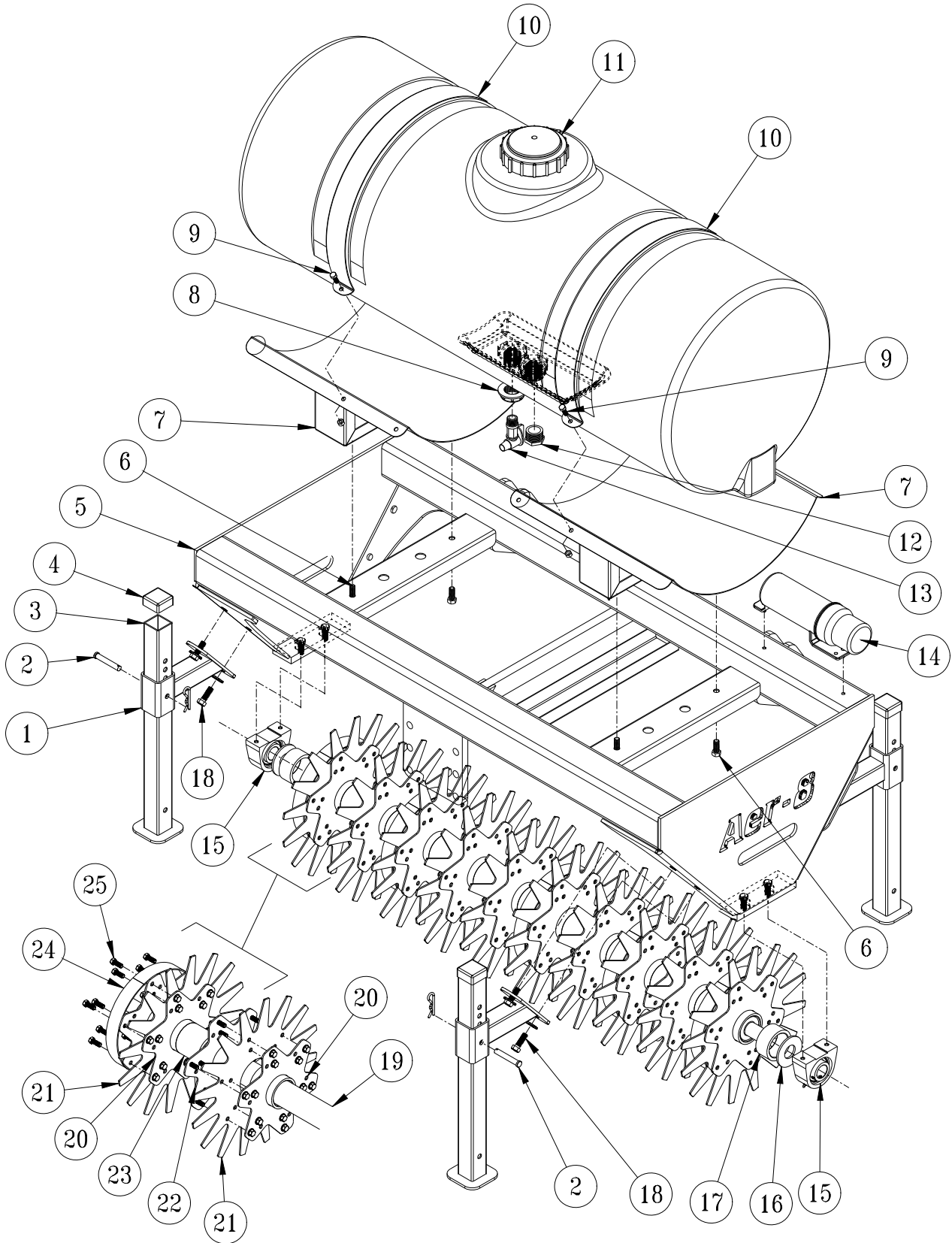

Parts

## AER-8 "AERFINE" 5" SPACING PARTS LIST

| REF#                | PART#        | DESCRIPTION                  | QUANTITY |
|---------------------|--------------|------------------------------|----------|
| 1                   | 74-228       | Kickstand Mount              | 4        |
| 2                   | HCP-12-300   | Clevis Pin, 1/2 x 3          | 4        |
|                     | HHP-177      | Bridge Pin, .177 x 3 3/4     | 4        |
| 3                   | 74-227       | Kickstand Leg                | 4        |
| 4                   | 16-557       | Square Cap                   | 4        |
| 5                   | 74-245       | Mainframe, 60"               | 1        |
|                     | 74-280       | Mainframe, 78"               | 1        |
|                     | 74-157       | Decal, Aer-8                 | 2        |
| 6                   | HB-12-13-125 | Hex Bolt, 1/2 - 13 x 1 1/4   | 4        |
|                     | HNFL-12-13   | Flange Lock Nut, 1/2 - 13    | 4        |
| 7                   | 74-243       | Tank Carrier                 | 2        |
| 8                   | 16-150       | Double Thread Fitting        | 1        |
| 9                   | HB-38-16-275 | Hex Bolt, 3/8 - 16 x 2 1/4   | 4        |
|                     | HNTL-38-16   | Lock Nut, 3/8 - 16           | 4        |
| 10                  | 74-242       | Tank Strap                   | 2        |
| 11                  | 74-211       | 100 Gal. Tank                | 1        |
| 12                  | 10-389       | Plug, 1 1/4                  | 1        |
| 13                  | 16-960       | Spigot                       | 1        |
| 14                  | 74-213       | Bearing                      | 2        |
|                     | HB-12-13-175 | Hex Bolt, 1/2 - 13 x 1 3/4   | 4        |
|                     | HW-12        | Flat Washer, 1/2             | 4        |
|                     | HWL-12       | Lock Washer, 1/2             | 4        |
| 15                  | HB-12-13-125 | Hex Bolt, 1/2 - 13 x 1 1/4   | 8        |
|                     | HNFL-12-13   | Flange Lock Nut, 1/2 - 13    | 8        |
| <b>60" AER8-606</b> |              |                              |          |
| 16*                 | 74-239       | 60" Core/Fine Shaft          | 1        |
| 17*                 | 74-251       | Core Tine Wheel              | 10       |
| 18*                 | 74-265       | "Aerfine" Ultra-Fine Blade   | 10       |
| 19*                 | 74-264       | Plate                        | 5        |
| 20*                 | 74-240       | Spacer Tube                  | 9        |
| 21*                 | 74-269       | Depth Spacer                 | 5        |
| 22*                 | HB-38-16-100 | Bolt, 3/8 - 16 x 1           | 120      |
|                     | HNFL-38-16   | Flange Lock Nut, 3/8 - 16    | 120      |
| 23                  | 74-215       | Shaft Flange                 | 2        |
| 24                  | 74-281       | 1 1/2" Spacer                | 2        |
| *                   | AER8-60R606  | 60" Aerfine 5" Reel Assembly |          |
| <b>78" AER8-786</b> |              |                              |          |
| 16**                | 74-262       | 78" Core/Fine Shaft          | 1        |
| 17**                | 74-251       | Core Tine Wheel              | 15       |
| 18**                | 74-265       | "Aerfine" Ultra-Fine Blade   | 15       |
| 19**                | 74-264       | Plate                        | 9        |
| 20**                | 74-240       | Spacer Tube                  | 14       |
| 21**                | 74-269       | Depth Spacer                 | 6        |
| 22**                | HB-38-16-100 | Bolt, 3/8 - 16 x 1           | 270      |
|                     | HNFL-38-16   | Flange Lock Nut, 3/8 - 16    | 270      |
| 23                  | 74-215       | Shaft Flange                 | 2        |
| 24                  | 74-283       | 1/2" Spacer                  | 2        |
| **                  | AER8-78R786  | 78" Aerfine 5" Reel Assembly |          |

# AER-8 CORING TINES DRAWING

Parts

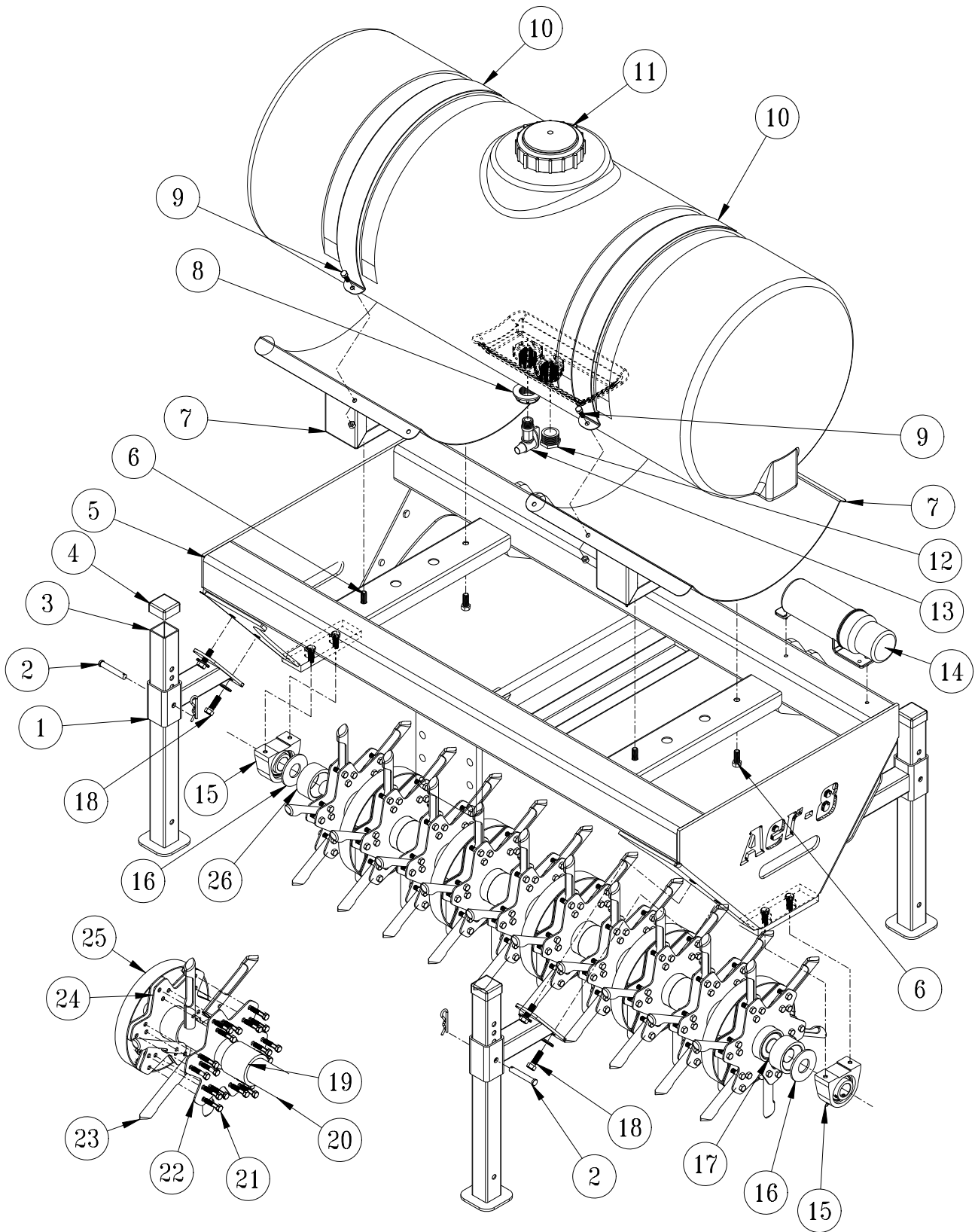



## AER-8 CORING TINES PARTSLIST

| REF#                | PART#        | DESCRIPTION                   | QUANTITY |
|---------------------|--------------|-------------------------------|----------|
| 1                   | 74-228       | Kickstand Mount               | 4        |
| 2                   | HCP-12-300   | Clevis Pin, 1/2 x 3           | 4        |
|                     | HHP-177      | Bridge Pin, .177 x 3 3/4      | 4        |
| 3                   | 74-227       | Kickstand Leg                 | 4        |
| 4                   | 16-557       | Square Cap                    | 4        |
| 5                   | 74-245       | Mainframe, 60"                | 1        |
|                     | 74-280       | Mainframe, 78"                | 1        |
|                     | 74-157       | Decal, Aer-8                  | 2        |
| 6                   | HB-12-13-125 | Hex Bolt, 1/2 - 13 x 1 1/4    | 4        |
|                     | HNFL-12-13   | Flange Lock Nut, 1/2 - 13     | 4        |
| 7                   | 74-243       | Tank Carrier                  | 2        |
| 8                   | 16-150       | Double Thread Fitting         | 1        |
| 9                   | HB-38-16-275 | Hex Bolt, 3/8 - 16 x 2 2/4    | 4        |
|                     | HNTL-38-16   | Lock Nut, 3/8 - 16            | 4        |
| 10                  | 74-242       | Tank Strap                    | 2        |
| 11                  | 74-211       | 100 Gal. Tank                 | 1        |
| 12                  | 10-389       | Plug, 1 1/4                   | 1        |
| 13                  | 16-960       | Spigot                        | 1        |
| 14                  | 74-213       | Bearing                       | 2        |
|                     | HB-12-13-175 | Hex Bolt, 1/2 - 13 x 1 3/4    | 4        |
|                     | HW-12        | Flat Washer, 1/2              | 4        |
|                     | HWL-12       | Lock Washer, 1/2              | 4        |
| 15                  | 74-215       | Shaft Flange                  | 2        |
| 16                  | HB-12-13-125 | Hex Bolt, 1/2 - 13 x 1 1/4    | 8        |
|                     | HNFL-12-13   | Flange Lock Nut, 1/2 - 13     | 8        |
| <b>60" AER8-607</b> |              |                               |          |
| 17*                 | 74-239       | 60" Core/Fine Shaft           | 1        |
| 18*                 | 74-240       | Spacer Tube                   | 9        |
| 19*                 | HB-38-16-175 | Bolt, 3/8 - 16 x 1 3/4        | 180      |
|                     | HNFL-38-16   | Flange Lock Nut, 3/8 - 16     | 180      |
| 20*                 | 74-264       | Plate                         | 10       |
| 21*                 | 74-225       | Coring Tine                   | 60       |
| 22*                 | 74-251       | Core Tine Wheel               | 10       |
| 23                  | 74-281       | 1 1/2" Spacer                 | 2        |
| 24*                 | 74-269       | Depth Spacer                  | 5        |
| *                   | AER8-60R607  | 60" Coring Tine Reel Assembly |          |
| <b>78" AER8-787</b> |              |                               |          |
| 17**                | 74-262       | 78" Core/Fine Shaft           | 1        |
| 18**                | 74-240       | Spacer Tube                   | 14       |
| 19**                | HB-38-16-175 | Bolt, 3/8 - 16 x 1 3/4        | 270      |
|                     | HNFL-38-16   | Flange Lock Nut, 3/8 - 16     | 270      |
| 20**                | 74-264       | Plate                         | 9        |
| 21**                | 74-225       | Coring Tine                   | 90       |
| 22**                | 74-251       | Core Tine Wheel               | 15       |
| 23                  | 74-283       | 1/2" Spacer                   | 2        |
| 24**                | 74-269       | Depth Spacer                  | 6        |
| **                  | AER8-78R787  | 78" Coring Tine Reel Assembly |          |

# REAR ROLLER DRAWING

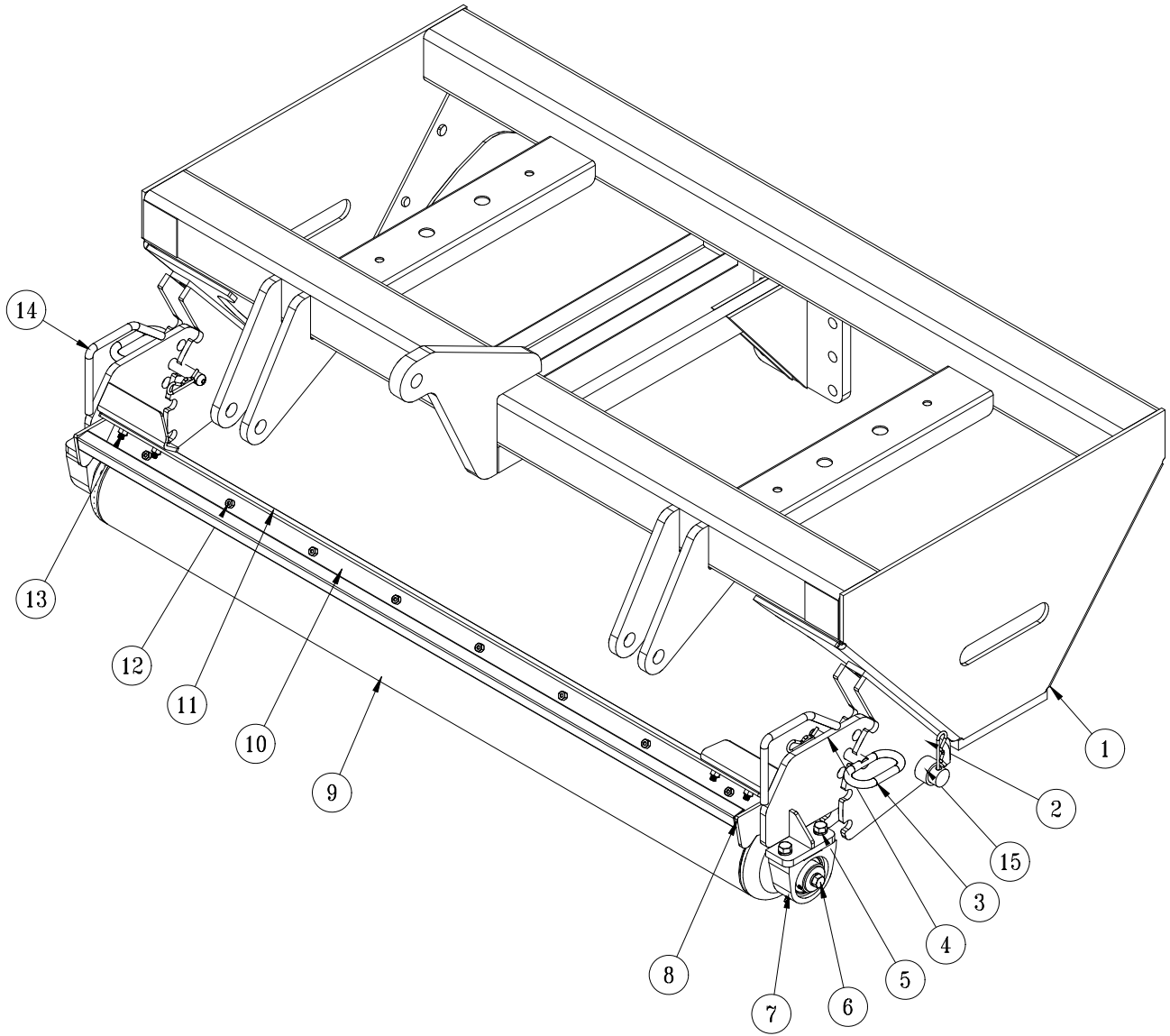

Parts

## REAR ROLLER PARTSLIST

| REF#                | PART#          | DESCRIPTION                                   | QUANTITY |
|---------------------|----------------|---|----------|
| 1                   | 74-245         | Mainframe, 60"                                | 1        |
|                     | 74-280         | Mainframe, 78"                                | 1        |
| 2                   | 74-247         | Adjustment Bracket                            | 2        |
|                     | HB-12-13-125   | Hex Bolt, $\frac{1}{2}$ - 13 x $1\frac{1}{4}$ | 8        |
|                     | HNFL-12-13     | Flange Lock Nut, $\frac{1}{2}$ - 13           | 8        |
| 3                   | 7-029          | Hitch Pin                                     | 2        |
| 4                   | 74-249         | RH Roller Bracket                             | 1        |
|                     | HG-14-28-180   | Grease Fitting                                | 1        |
| 5                   | HB-12-13-175   | Bolt, $\frac{1}{2}$ - 13 x $1\frac{3}{4}$     | 4        |
| 6                   | HB-12-13-125   | Bolt, $\frac{1}{2}$ -13 x $1\frac{1}{4}$      | 2        |
|                     | HW-58          | Washer, $\frac{5}{8}$                         | 2        |
| 7                   | 74-213         | Bearing                                       | 2        |
| 13                  | HB-38-16-125   | Bolt, $\frac{3}{8}$ - 16 x $1\frac{1}{4}$     | 4        |
|                     | HNTL-38-16     | Lock Nut, $\frac{3}{8}$ - 16                  | 4        |
| 14                  | 74-250         | LH Roller Bracket                             | 1        |
|                     | HG-14-28-180   | Grease Fitting                                | 1        |
| 15                  | 74-278         | Spacer  | 2        |
| <b>60" AER8-610</b> |                |   |          |
| 8                   | 74-261         | 60" Scraper Bar                               | 1        |
| 9                   | 74-260         | 60" Roller                                    | 1        |
| 10                  | 74-256         | 60" Scraper                                   | 1        |
| 11                  | 74-255         | 60" Scraper Strap                             | 1        |
| 12                  | HBC-516-18-100 | Carriage Bolt, $\frac{5}{16}$ -18 x 1         | 8        |
|                     | HNTL-516-18    | Lock Nut, $\frac{5}{16}$ - 18                 | 8        |
| <b>78" AER8-710</b> |                |   |          |
| 8                   | 74-286         | 78" Scraper Bar                               | 1        |
| 9                   | 74-287         | 78" Roller                                    | 1        |
| 10                  | 74-285         | 78" Scraper                                   | 1        |
| 11                  | 74-284         | 78" Scraper Strap                             | 1        |
| 12                  | HBC-516-18-100 | Carriage Bolt, $\frac{5}{16}$ -18 x 1         | 10       |
|                     | HNTL-516-18    | Lock Nut, $\frac{5}{16}$ - 18                 | 10       |

## *DECAL LIST*

|        |                       |                         |
|--------|-----------------------|-------------------------|
| 74-156 | Decal, Reflector      | 4 corners of main frame |
| 74-157 | Decal, Aer-8          | Main Frame Sides        |
| 74-210 | Decal Hang Tag        | Aer 8-002               |
| 76-305 | Decal, Rotating Parts | Reel Housing            |

## *QUICK REFERENCE*

|                               |   |
|-------------------------------|---|
| <b>BATTERY (NOT SUPPLIED)</b> | <b>AUTOMOTIVE TYPE 24F-12 VOLT</b>          |
| <b>HYDRAULIC FLUID</b>        | <b>HYDRAULIC FLUID 1.25 GAL (4.3 LITER)</b> |

# The Smithco Commercial Products Two-Year Limited Warranty

Smithco, Inc. (Smithco) warrants your 2007 or newer Smithco Commercial Product ("Product") purchased after January 1, 2007, to be free from defects in materials or workmanship for the period of time listed below. Where a warrantable condition exists, Smithco will repair the Product at no cost to you including diagnosis, labor (at the Smithco standard labor rate, subject to the Smithco flat rate schedule), and parts.

## Warranty Duration is:

- (1) Two years, 1500 operational hours\* from the date of delivery to the original purchaser or three years from the date of original manufacturer of the product, whichever occurs first. (\*Products equipped with hour meter).
- (2) Products used in rental situations are covered for 90 days from date of delivery to original user/ renter.

## Owner Responsibilities:

As the Product owner, you are responsible for required maintenance and adjustments stated in your Owner's Manual. Failure to perform required maintenance and adjustments can be grounds for disallowing a warranty claim. **You are particularly responsible to train all present and future operators of this product on the safe operation of this product at your location.**

## Instructions for Obtaining Warranty Service:

You are responsible for notifying the Authorized Smithco Products Distributor from whom you purchased the Product as soon as you believe a warrantable condition exists and not later than 30 days from discovery of the condition.

If you need help locating an Authorized Smithco Distributor, or if you have questions regarding your warranty rights or responsibilities, you may contact us at:

Smithco Product Support Department  
200 W Poplar PO Box 487  
Cameron, Wisconsin 54822

Telephone: 1-800-891-9435      E-Mail: [ProductSupport@smithco.com](mailto:ProductSupport@smithco.com)

## Maintenance Parts:

Parts scheduled for replacement as required maintenance ("Maintenance Parts"), are warranted for the period of time up to the scheduled replacement time for that part.

### Items/Conditions Not Covered:



Not all product failures or malfunctions that occur during the warranty period are defects in materials or workmanship. The items/conditions listed below are not covered by this warranty:



Product failures which result from the use of non-Smithco replacement parts, or from installation and use of add-on, modified, or unapproved accessories are not covered.



Product failures which result from failure to perform required maintenance and/or adjustments are not covered.



Product failures that result from operating the Product in an abusive, negligent or reckless manner are not covered.



This warranty does not apply to parts subject to consumption through use, unless found to be defective. Examples of parts which are consumed, or used up, during normal Product operation include, but are not limited to: blades, tines, teeth, scarifiers, rakes, plates, wear plates, castor wheels, tires, batteries, filters, belts, nozzles, etc.



This warranty does not apply to failures caused by outside influence. Items considered to be outside influence include, but are not limited to, weather, storage practices, contamination, use of unapproved coolants, lubricants, additives, or chemicals, etc.



This warranty does not apply to normal “wear and tear” items. Normal “Wear and Tear” includes, but is not limited to, damage to seats due to wear or abrasion, worn painted surfaces, scratched decals or windows, etc.



Smithco may require the return of failed parts or components in order to determine the validity of any warranty claim.



Smithco will not be obligated to replace components of other manufacturers if inspection by the original component manufacturer indicates that failure was due to normal wear and tear, expected consumption through use or improper care or service.

#### **Other Legal Disclaimers:**

The above remedy for product defects through repair or replacement by an authorized Smithco distributor or dealer is the purchaser’s sole remedy for any defect. This warranty gives you specific legal rights, and you may also have other rights which vary from state to state.

**THERE ARE NO OTHER EXPRESS WARRANTIES OTHER THAN THOSE SET FORTH ABOVE. ALL IMPLIED WARRANTIES OF MERCHANTABILITY AND FITNESS FOR USE ARE LIMITED TO THE DURATION OF THE LIMITED WARRANTIES CONTAINED HEREIN.**

Some states may not allow limitations on how long an implied warranty lasts, so the above limitation may not apply to you.

**THE SMITHCO COMPANY IS NOT LIABLE FOR INDIRECT, INCIDENTAL OR CONSEQUENTIAL DAMAGES IN CONNECTION WITH THE USE OF THE PRODUCT, INCLUDING ANY COST OR EXPENSE OF PROVIDING A SUBSTITUTE PRODUCT OR SERVICE DURING PERIODS OF MALFUNCTION OR NON-USE.**

Some states may not allow the exclusion of indirect, incidental or consequential damages, so the above exclusion may not apply to you.

**Smithco neither assumes, nor authorizes any person to assume for it, any other liability in connection with the sale or use of this product.**

**SMITHCO, INC.**

**Wayne, PA 19087**

