

SMITHCO

Wayne, Pennsylvania 19087

PARTS & SERVICE MANUAL

SUPER RAKE 2 WHEEL DRIVE Model 13-551-D Bunker Rake

SUPER RAKE 3 WHEEL DRIVE Model 13-550-D Bunker Rake

Starting Serial #1200 (2WD)
Starting Serial #6450 (3WD)

March, 2002

Updated October 2005

SMITHCO PRODUCT SUPPORT
1-800-891-9435
Hwy SS and Poplar Avenue, Cameron WI 54822
E-mail: productsupport@smithco.com

CONTENTS

Introduction

Introduction 1-4

Introduction	1
Safe Practices	2
Specifications	3
Optional Equipment	4

Service

Service 5-11

Maintenance	5-7
Service Chart	8
End User's Service Chart	9
Adjustments	10-11
Storage	11

Diagrams

Diagrams 12-17

Wiring Diagram	12-13
Hydraulic Diagram	14-15
Wiring Schematic	16
Hydraulic Schematic	17

Parts

Parts 18-51

Main Frame	18-21
Accelerator Linkage	22-23
Right Fender and Engine	24-27
Left Fender and Tank	28-29
Two Wheel Drive Front Fork	30-31
Three Wheel Drive Front Fork	32-33
Engine and Pump	34-35
Rear Axle	36-37
Hydraulic Oil Filter	38-39
Hydraulic Oil Tank	38-39
Rear Rake Lift	40-41
On-Off Valve (3WD only)	42-43
13-729 2-Bank Hydraulic Valve	44-45
13-110 Variable Pump	46-47
13-032 Front Wheel Motor (4.9 C.I.)	48-49
13-615 Rear Wheel Motor (7.5 C.I.)	50-51

Accessories

Accessories 52-105

13-505 Lift Assembly	52-53
13-680 Hydraulic Plow with Lift	54-57
13-679 Hydraulic Plow with Lift	54-57
13-730 3-Bank Hydraulic Valve	58-59
13-644 Manual Plow	60-63
13-678 Castor Wheel Kit	64-65
13-107 Scarifier with Chisel Blades	66-67
13-577 Scarifier Vertical Blades	68-69
13-116 Sand Cultivator	70-71
13-199 Edger Kit	72-73
13-111 Drag Mat Kit	74-75
42-026 84" SS Tournament Rake	76-79
42-128 72" SS Tournament Rake	80-83
13-438 Rake Assembly	84-85
13-606 Rake Assembly (Lexan)	86-87
13-684 Brush Kit for 13-438 and 13-606 ...	88-89
13-298 Fan Rake Attachment	90-91
26-007 Professional Infield Finisher	92-93
26-008 Flex Action Field Finisher	94-97
34-191 Box Grader	98-101
42-586 Spiker	102-103
42-586 Spiker Main Frame	104-105

Reference 107-108

Decal List	107
Quick Reference Replacement Parts	108
Warranty	Inside Back Cover

Reference

Thank you for purchasing a **SMITHCO** product.

Read this manual and all other manuals pertaining to the Super Rake carefully as they have safety, operating, assembly and maintenance instructions. Failure to do so could result in personal injury or equipment damage.

Keep manuals in a safe place after operator and maintenance personnel have read them. Right and left sides are from the operator's seat, facing forward.

All **SMITHCO** machines have a Serial Number and Model Number. Both numbers are needed when ordering parts. The serial number plate on the Super Rake is located on the right side main frame. Refer to engine manual for placement of engine serial number.

For easy access record your Serial and Model numbers here.

SMITHCO		DATE OF MFG.
WAYNE, PENNSYLVANIA 19087 USA 610-688-4009 Fax 610-688-6069		<input type="text"/>
SERIAL NO.	<input type="text"/>	kW/hp <input type="text"/>
MODEL NO.	<input type="text"/>	kg/lb <input type="text"/>



Information needed when ordering replacement parts:

1. Model Number of machine
2. Serial Number of machine
3. Name and Part Number of part
4. Quantity of parts

SAFE PRACTICES

1. It is your responsibility to read this manual and all publications associated with this machine (engine, accessories and attachments).
2. Never allow anyone to operate or service the machine or its attachments without proper training and instructions. Never allow minors to operate any equipment.
3. Learn the proper use of the machine, the location and purpose of all the controls and gauges before you operate the equipment. Working with unfamiliar equipment can lead to accidents.
4. Wear all the necessary protective clothing and personal safety devices to protect your head, eyes, ears, hands and feet. Operate the machine only in daylight or in good artificial light.
5. Inspect the area where the equipment will be used. Pick up all debris you can find before operating. Beware of overhead obstructions and underground obstacles. Stay alert for hidden hazards.
6. Never operate equipment that is not in perfect working order or without decals, guards, shields, or other protective devices in place.
7. Never disconnect or bypass any switch.
8. Carbon monoxide in the exhaust fumes can be fatal when inhaled, never operate a machine without proper ventilation.
9. Fuel is highly flammable, handle with care.
10. Keep engine clean. Allow the engine to cool before storing and always remove the ignition key.
11. After engine has started, machine must not move. If movement is evident, the neutral mechanism is not adjusted correctly. Shut engine off and readjust so the machine does not move when in neutral position.
13. Never use your hands to search for oil leaks. Hydraulic fluid under pressure can penetrate the skin and cause serious injury.
14. This machine demands your attention. To prevent loss of control or tipping of the vehicle:
 - A. Use extra caution in backing up the vehicle. Ensure area is clear.
 - B. Do not stop or start suddenly on any slope.
 - C. Reduce speed on slopes and in sharp turns. Use caution when changing directions on slopes.
 - D. Stay alert for holes in the terrain and other hidden hazards.
15. Before leaving operator's position for any reason:
 - A. Disengage all drives.
 - B. Lower all attachments to the ground.
 - C. Set park brake.
 - D. Shut engine off and remove the ignition key.
16. Keep hands, feet and clothing away from moving parts. Wait for all movement to stop before you clean, adjust or service the machine.
17. Keep the area of operation clear of all bystanders.
18. Never carry passengers.
19. Stop engine before making repairs/adjustments or checking/adding oil to the crankcase.
20. Use parts and materials supplied by SMITHCO only. Do not modify any function or part.

These machines are intended for professional maintenance on golf courses, sports turf, and any other area maintained turf and related trails, paths and lots. No guaranty as to the suitability for any task is expressed or implied.

WEIGHTS AND DIMENSIONS

Length with Rake	85" (2.16 m)
Width with Rake	73.5" (1.87 m)
Width without Rake	70" (1.77 m)
Height	44" (1.12 m)
Wheel Base	47" (1.19 m)
Weight	990 lbs (449 kg)

SOUND LEVEL AT 3200 RPM

At ear level -	88 dB
At 3 ft (0.914 m)	94 dB
At 30 ft (9.14 m)	83 dB

ENGINE

Make	Briggs and Stratton Vanguard
Model#	303447
Type / Spec#	1018A2
Horsepower	16 Hp (12 kW)
Fuel	Unleaded 85 Octane Gasoline Minimum
Cooling System	Air Cooled
Lubrication System	Pressure type
Alternator	16 amp

WHEELS & TIRE

(3) 21 x 11.00 x 8 NHS 5 psi (0.35 bar)
 Front tire fluid filled to 60lbs. total; 34.5 pints of windshield washer fluid or equivalent.

SPEED

Forward Speed	0 to 10 mph (0-16 kph)
Reverse Speed	0 to 4 mph (0-6 kph)

BATTERY (Not Included)

Automotive type	45-12 volt
BCI Group	Size 45
Cold Cranking Amps	480
Ground Terminal Polarity	Negative (-)
Maximum Length	9" (23 cm)
Maximum Width	5.38" (14 cm)
Maximum Height	9" (23 cm)

FLUID CAPACITY

Crankcase Oil	Approximately 1.5 quart (1.4 liters) without filter Approximately 1.75 quart (1.7 liters) with filter
Fuel	15.6 quart (14.8 liters)
Hydraulic Fluid	12.9 quart (12.2 liters)
Grade of Hydraulic Fluid	SAE 10W-40 API Service SJ or higher

OPTIONAL EQUIPMENT

13-680	Hydraulic Plow (Dealer Installed)	13-678	Castor Wheel Kit
13-644	Manual Plow, Aluminum Blade	13-298	Fan Rake Attachment
13-679	Hydraulic Plow (Factory Installed)	34-191	Box Grader
13-505	Attachment Lift (13-551 Only)	42-582	Spiker with 42-586 Main Frame
13-107	Infield Scarifier, Chisel Blades	26-007	Professional Infield Finisher
13-577	Infield Scarifier, Vertical Blades	26-008	Flex Action Field Finisher
13-116	Sand Cultivator	13-111	Drag Mat Kit
13-199	Edger Kit	42-550	Green Star Total RBS System
13-438	Rake Assembly	42-503	RBS Mount for Smithco Super Rake
13-606	Rake Assembly with Lexan Blades	42-586	Green Star RBS Main Frame Only
13-684	Brush Kit for 13-438 and 13-606	42-282	Green Star Spiker Set
42-026	84" Stainless Steel Tournament Rake	42-531	22-11.00 x 8 Custom Smooth Tread Tire
42-128	72" Stainless Steel Tournament Rake	42-530	22-11.00 x 8 Turf Track R/S Tire
42-794	Trap Rake Ball Mount Kit	43-002	Flex Action Field Finisher with Brush
43-043	Brush Only for 43-002		



Before servicing or making adjustments to machine, stop engine and remove key from ignition.

CAUTION

NOTE:

Use all procedures and parts prescribed by the manufacturer's. Read the engine manual before operation.

The suggested maintenance checklist is not offered as a replacement for the manufacturer's but as a supplement. You must adhere to guidelines established by manufacturer for warranty coverage. In adverse conditions such as dirt, mud or extreme temperatures, maintenance should be more frequent.

LUBRICATION

Use No. 2 General purpose Lithium Base Grease and lubricate every 100 hours. The Super Rake has two grease fittings. One is located in bearing on steering shaft and the other is on the rake lift assembly.

AIR CLEANER ON ENGINE

1. Unhook clips on both sides of cover and remove cover.
2. Carefully slide pre-cleaner off cartridge.

To service pre-cleaner, wash in liquid detergent and water. Squeeze dry in a clean cloth. Saturate in engine oil. Squeeze in clean, absorbent cloth to remove all excess oil. Replace if very dirty or damaged.

3. Remove knob and plate. Carefully remove cartridge to prevent debris from entering carburetor. To service cartridge, clean by tapping gently on flat surface. Do not oil cartridge. Replace if very dirty or damaged.

NOTE: Do not use petroleum solvents, e.g., kerosene, which will cause cartridge to deteriorate. Do not use pressurized air to clean cartridge. Pressurized air can damage cartridge.

4. Reinstall cartridge, plate and knob.
5. Reassemble pre-cleaner on cartridge.
6. Replace cover and reattach clips to body.

AIR CLEANER ON FENDER

1. Remove end cap and filter element, clean by tapping gently on flat surface. Do not oil cartridge. Replace if very dirty or damaged.
2. Remove air cleaner cap and clean. Cap can be washed in solvent, make sure its dry before reinstalling.

HYDRAULIC OIL

1. Use SAE 10W-40 API Service SJ or higher motor oil.
2. For proper warranty, change oil every 500 hours or annually, which ever is first and change filter after the first 20 hours, then at 100 hours, then every 250 hours thereafter.
3. The oil level should be 2" to 2 1/2" from top of tank when fluid is cold. Do not overfill.
4. After changing oil and/or filter, run the machine for a few minutes. Check oil level and for leaks.
5. Always use caution when filling hydraulic oil tank or checking level to keep system free of contaminants. Check and service more frequently when operating in extremely cold, hot or dusty conditions.
6. If natural color of fluid is now black or smells burnt, it is possible that an overheating problem exists.
7. If fluid becomes milky, water contamination may be a problem.
8. If either of the above conditions happen, change oil and filter immediately after fluid is cool and find cause. Take fluid level readings when system is cold.
9. In extreme temperatures you can use straight weight oil. We recommend SAE 30W API Service SJ or higher when hot (above 90°F (33°C)) and SAE 10W API Service SJ or higher when cold (below 32°F (0°C) ambient temperature. Use either motor oil or hydraulic oil, but do not mix.
10. Oil being added to the system must be the same as what is already in the tank. Mark tank fill area as to which type you put in.



MAINTENANCE

TIRE PRESSURE

Caution must be used when inflating a low tire to recommended pressure. Over inflating can cause tires to explode. Tires should be 5 psi (0.35 bar). Improper inflation will reduce tire life considerably.

ENGINE OIL

Change and add oil according to chart below. Do not overfill. Use a high quality detergent oil classified "For Service SJ or higher" SAE 30 oil. Use no special additives with recommended oils. Do not mix oil with gasoline.

SAE Viscosity Grades

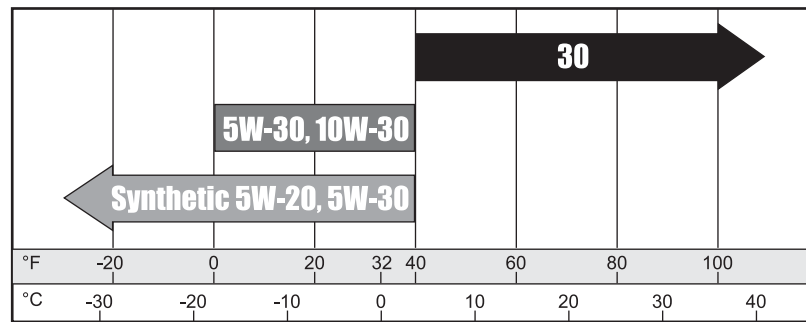

Starting Temperature Range Anticipated Before Next Oil Change

Air cooled engine run hotter than automotive engines. Use of multi-viscosity oils (10W-30, etc.) above 40° F (4° C) will result in high oil consumption and possible engine damage. Check oil level more frequently if using these types of oils.

SAE 30 oil, if used below 40° F (4° C), will result in hard starting and possible engine bore damage due to inadequate lubrication.

TOWING

When it is necessary to move the Super Rake without engine running, bypass valve built into hydrostatic pump must be "open" by turning it counterclockwise. The valve is located on bottom left of pump. An "open" valve allows fluid to pass through the wheels freely. When normal, driven, operation is desired, valve should be "closed" by turning it clockwise. Failure to "close" the valve with engine running means no power to wheels. The machine can be moved for a short distance with the engine off, but we **do not** recommend this as a standard procedure. When towing **do not** tow the machine faster than 2-3 MPH (3-5 km/h) because the drive system may be damaged. The tires may lock up if the machine is towed too fast. If this occurs, stop towing the machine. If the machine must be moved a considerable distance, transport it on a truck or trailer.

WHEEL MOUNTING PROCEDURE

1. Set park brake. Turn machine off and remove key.
2. Block one of the other wheels.
3. Loosen nuts slightly on wheel to be removed.
4. Jack up machine being careful not to damage underside of machine.
5. Remove nuts, remove Wheel.
5. Place new wheel on hub lining up bolt holes.
6. Torque nuts to 64-74 ft/lb (87-100 Nm) using a cross pattern. Retorque after first 10 hours and every 200 hours thereafter.
7. Lower machine to ground and remove blocks and jack.

BATTERY

Batteries normally produce explosive gases which can cause personal injury. Do not allow flames, sparks or any ignited object to come near the battery. When charging or working near battery, always shield your eyes and always provide proper ventilation.

Battery cable should be disconnected before using "Fast Charge".

Charge battery at 15 amps for 10 minutes or 7 amps for 30 minutes. Do not exceed the recommended charging rate. If electrolyte starts boiling over, decrease charging.

Always remove grounded (-) battery clamp first and replace it last. Avoid hazards by:

1. Filling batteries in well-ventilated areas.
2. Wear eye protection and rubber gloves.
3. Avoid breathing fumes when electrolyte is added.
4. Avoid spilling or dripping electrolyte.



Battery Electrolyte is an acidic solution and should be handled with care. If electrolyte is splashed on any part of your body, flush all contact areas immediately with liberal amounts of water. Get medical attention immediately.

JUMP STARTING



Use of booster battery and jumper cables. Particular care should be used when connecting a booster battery. Use proper polarity in order to prevent sparks.

To jump start (negative grounded battery):

1. Shield eyes.
2. Connect ends of one cable to positive (+) terminals of each battery, first (A) then (B).
3. Connect one end of other cable to negative (-) terminal of "good" battery (C).
4. Connect other end of cable (D) to engine block on unit being started (NOT to negative (-) terminal of battery)

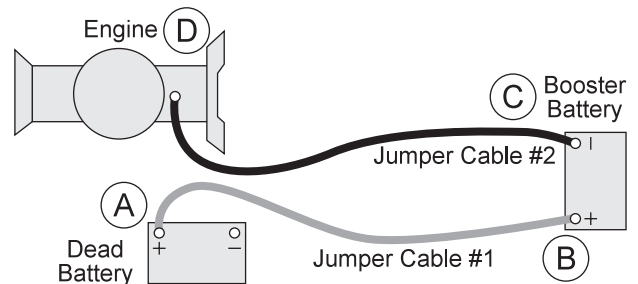

To prevent damage to other electrical components on unit being started, make certain that engine is at idle speed before disconnecting jumper cables.

SERVICE CHART



Before servicing or making adjustments to the machine, stop engine, set park break, block wheels and remove key from ignition.



Follow all procedures and ONLY use parts prescribed by the manufacturer. Read the engine manual before maintenance.

	Daily	As Required	100 Hours	200 Hours	250 Hours	300 Hours	400 Hours	Every 500 Hours/Yearly
⌘ Engine Oil (Change every 50 hours)	C	R	R	R	R	R	R	R
⌘ Engine Oil Filter			R	R		R	R	R
Engine for Leaks and Loose Parts	C		C	C		C	C	C
‡ Air Cleaner, Engine and Fender Mounted		R	C	C		C	C	R
‡ Air Cleaner Pre-Cleaner		R	C	C		C	C	R
Spark Plugs							C	R
Valve Clearance								C
Idle Speed		C						C
Air Cooling System	C		C	C		C	C	C
Hoses	C				C			C
* Tire Pressure	C		C	C		C	C	C
Visual Inspection of Tires	C		C	C		C	C	C
Fuel Level	C	C						
Fuel Filter		R						R
Hydraulic Oil	C		C	C		C	C	R
† Hydraulic Oil Filter					R			R
Hydraulic System for Leaks and Loose Parts	C		C	C		C	C	C
Battery Electrolyte Level			C	C		C	C	C
Clean Battery Terminals					C			C
§ Torque Lug Nuts				C			C	C
Lubricate			C	C		C	C	C

C=Check or Clean at specified intervals

R=Replace at specified intervals

* Tire pressure: 5 psi (0.35 bar)

† Replace hydraulic filters after the first 20, 100, and every 250 there after.

§ Torque tire nuts after the first 10 hours and every 200 hours there after (64 to 74 ft/lb (87-100 Nm))

⌘ Change Oil and Filter after first 8 hours.

£ Change oil every 25 hours when operating under heavy load or in high ambient temperatures.

‡ Clean more often under dusty conditions or when airborne debris is present, replace air cleaner parts, if very dirty.

The suggested maintenance checklist is not offered as a replacement for the manufacturer's engine manual but as a supplement. You must adhere to the guidelines established by the manufacturer for warranty coverage. In adverse conditions such as dirt, mud or extreme temperatures, maintenance should be more frequent.

END USER'S SERVICE CHART

	Daily	As Required	100 Hours	200 Hours	250 Hours	300 Hours	400 Hours	Every 500 Hours/Yearly
⌘ Engine Oil								
⌘ Engine Oil Filter								
Engine for Leaks and Loose Parts								
‡ Air Cleaner (Paper Element)								
‡ Pre-Cleaner (Every 25 hours)								
Spark Plugs								
Valve Clearance								
Idle Speed								
Air Cooling System								
Hoses								
* Tire Pressure								
Visual Inspection of Tires								
Fuel Level								
Fuel Filter								
Hydraulic Oil								
† Hydraulic Oil Filter								
Hydraulic System for Leaks and Loose Parts								
Battery Electrolyte Level								
Clean Battery Terminals								
§ Torque Lug Nuts								
Lubricate								

Service

C=Check or Clean at specified intervals

R=Replace at specified intervals

*** Tire pressure: 5 psi (0.35 bar)**

† Replace hydraulic filters after the first 20, 100, and every 250 there after.

§ Torque tire nuts after the first 10 hours and every 200 hours there after (64 to 74 ft/lb (87-100 Nm))

⌘ Change Oil and Filter after first 8 hours.

£ Change oil every 25 hours when operating under heavy load or in high ambient temperatures.

‡ Clean more often under dusty conditions or when airborne debris is present , replace air cleaner parts, if very dirty.



ADJUSTMENTS

RAKE LIFT CYLINDER

Completely lower Rake Lift. Remove cotter pin (A) and clevis pin (B). Place attachment lift arms (C) at $\frac{1}{16}$ " above cross member (D) on Rake Lift. Loosen jam nut (E). Twist cylinder extension (F) so clevis pin end of cylinder extension lines up with holes in attachment lift arm. Replace clevis and cotter pins. Tighten jam nut. Raise and lower Rake Lift to check for proper clearance.

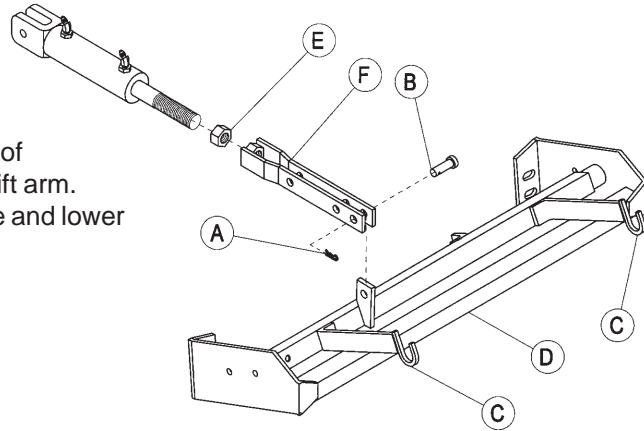

PARK BRAKE

By turning knob on end of lever you can tighten or loosen brake a small amount. Make all adjustments on knob. Adjusting yokes will result in cable kinking.

STEERING CHAIN

Steering sprockets (K) should be level with each other, check with straight edge. Make any adjustments. Slide idler pulley (J) so that it is snug onto the chain. Tighten all nuts and bolts in place.

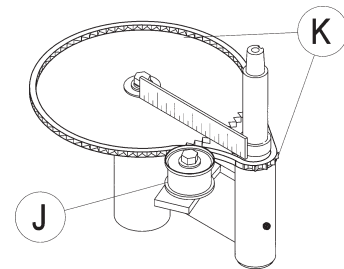

LIFT ASSEMBLY

When it is necessary to have attachment lift dig deeper or lower into ground, relocate cylinder rod of hydraulic cylinder which controls the lift distances, into lower set of holes in attachment lift swing arm. This new position forces attachment farther down.

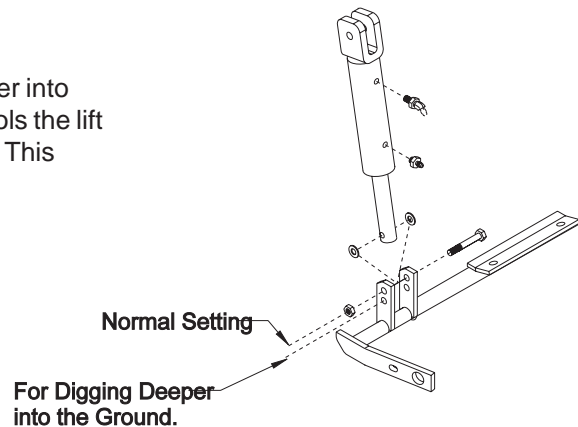

WHEEL 'CREEP' ADJUSTMENT

'Creep' is when engine is running and hydrostatic transmission is in neutral, but due to inadequate alignment wheels still move. Do the following procedures to stop this motion.

1. Lift up and support machine so all wheels are off the ground and can turn freely.
2. At rear of machine, on the bottom of the hydrostatic transmission is the shift arm (A). Loosen bolts (B).
3. With engine running move stop (C) so it moves shift arm (A) to center and wheel creep stops.
4. Tighten all fasteners and test by using foot pedal linkage to see that the "creep" is removed.
5. Turn engine off and lower machine.

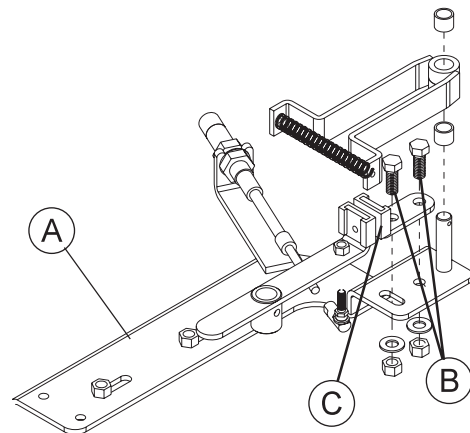

SPEED BOSS

Speed Boss allows the machine to operate at a proper speed while raking bunkers on golf courses. This speed has been factory set at an average speed of 3-4 MPH (5-6.5 kph). The Speed Boss will only limit the speed while the rake is in lowered into the operating position. The speed setting may be adjusted by removing the ball joint (A) from the linkage rod (B). Then loosen nut (C). Turn ball joint clockwise to make the machine operate faster or turn counter clockwise to go slower. Tighten jam nut. Connect ball joint to limiting arm. Check to make sure nothing is binding and test drive to check desired speed.

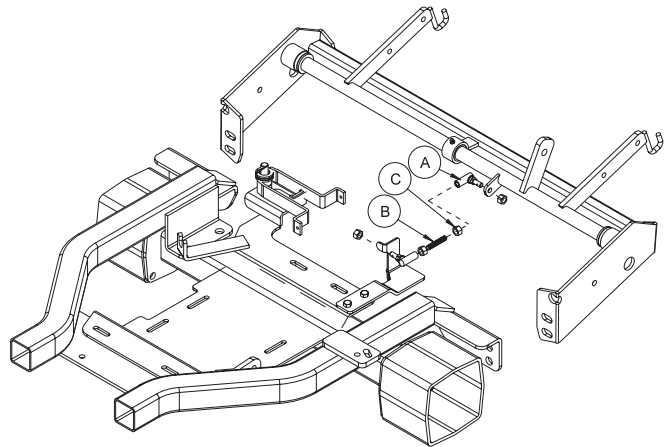

When the rear rake attachment is lowered while the machine is in forward position, the forward speed of the machine will slow drastically. Operator should be prepared for rapid change in speed.

STORAGE

Engines stored over 30 days need to be protected or drained of fuel to prevent gum from forming in a fuel system or on essential carburetor parts.

1. For engine protection, we recommend use of Briggs and Stratton Gasoline Additive, Part Number 5041, or a comparable gasoline additive. Mix Additive with fuel in fuel tank or storage container. Run engine for a short time to circulate additive through carburetor. Engine and fuel can be store up to 24 months. Your Service Dealer has single-use pouches of Gasoline Additive available.
2. If engine is still warm, drain oil from crankcase. Refill with fresh oil of recommended grade.
3. Remove spark plugs and pour about 1 oz. (3 ml) of engine oil into cylinders. Replace spark plugs and crank slowly to distribute oil.
4. Clean dirt and chaff from cylinders, cylinder head fins, blower housing, rotating screen and muffler area.
5. Store in a clean and dry area, but NOT near a stove, furnace or water heater which uses a pilot light or any device that can create a spark.

WIRING DIAGRAM

Color Code Chart

Bl	Blue
Br	Brown
Y	Yellow
Grn	Green
O	Orange
R	Red
B	Black
P	Purple
W	White

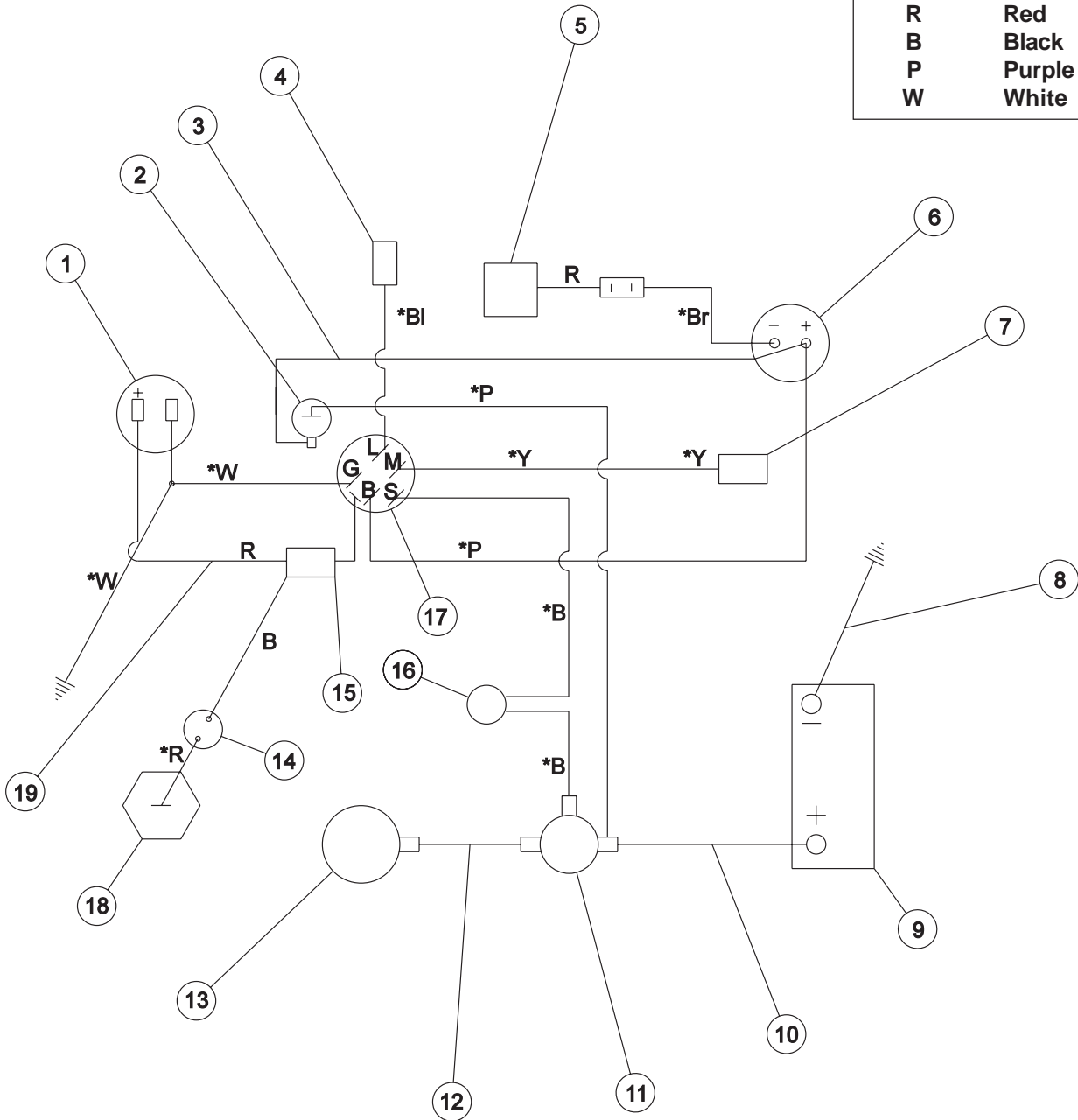

WIRING DIAGRAM

REF#	PART#	DESCRIPTION	QUANTITY
1	12-017	Hour Meter	1
2	50-360	Fuse Holder	1
	22-071	Fuse 30 AMP	1
3	13-050	Purple Wire (fuse to ammeter)	1
4		After Fire Solenoid (on engine)	1
5		Rectifier (on engine)	1
6	22-003	Ammeter	1
7		Stop Switch Terminal (on engine)	1
8	22-054	Battery Cable, Black	1
9		Battery, automotive type 45-12V; 480 cold cranking AMPS minimum (5 ³ / ₈ " wide x 9" high x 9" long)	1
10	22-055	Battery Cable, Red	1
	12-031	Battery Boot (comes with red battery cable)	1
11	13-492	Solenoid (B & S# 807829)	1
12	13-215	Starter Cable	1
13		Starter (on engine)	1
14	50-359	Oil Pressure Light	1
15	8862	Coupler	1
16	14-292	Seat Switch	1
17	13-488	Ignition Switch (B & S# 496603)	1
18	13-491	Oil Sender (on engine) (B & S# 692318)	1
19	13-641	Red Wire (ignition to hour meter)	1
	22-017	Ground Cable from Engine to Solenoid Mount	1
*	13-697	Wire Harness	

HYDRAULIC DIAGRAM

Diagrams

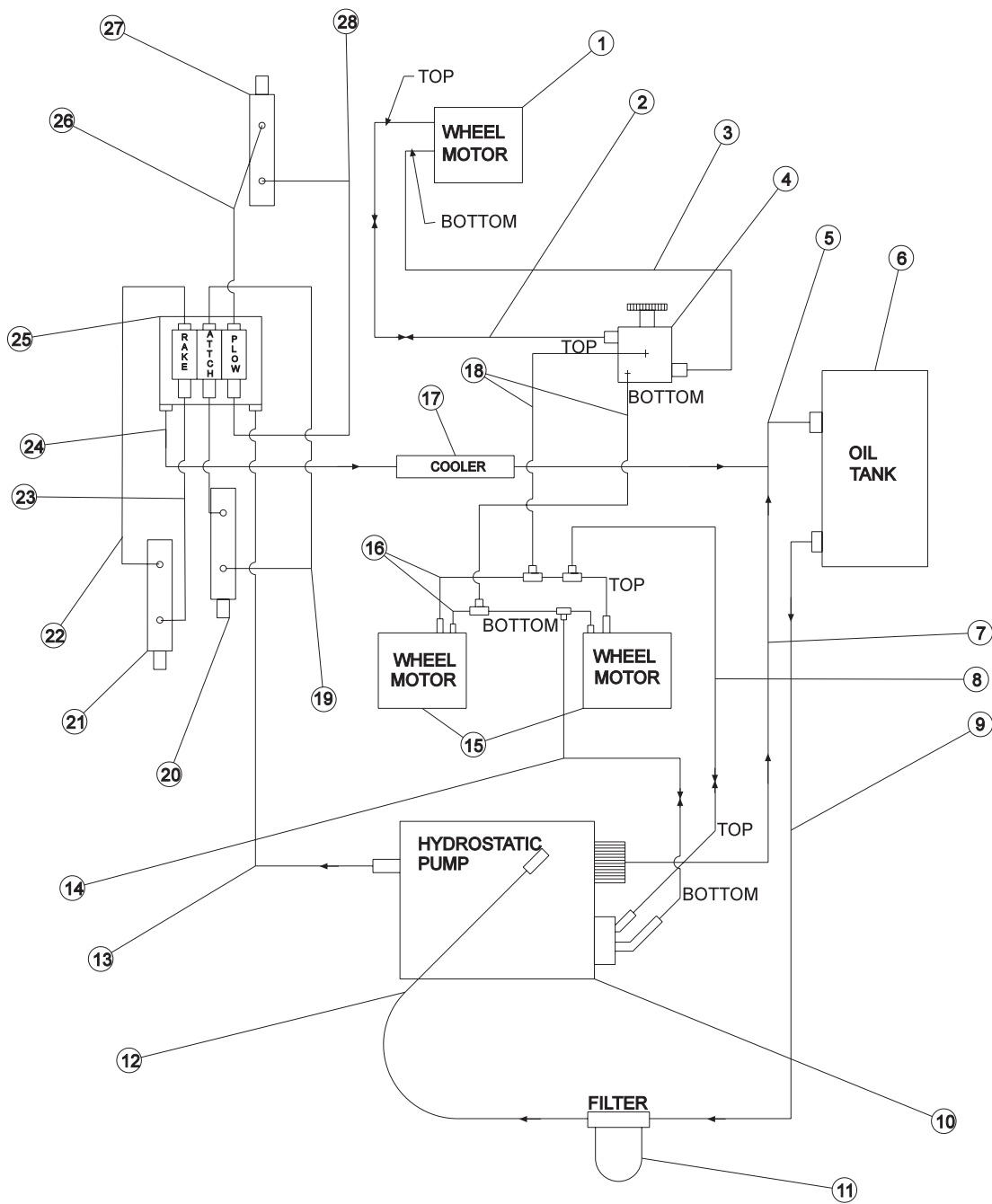

HYDRAULIC PRESSURES

Pump Displacement	.913 in. ³ / rev
Pump Input Speed (up to)	3600 rpm
Max. Operating Pressure	3500 psi, 4500 Peek psi
Charge Pump Displacement	.33 in. ³ / rev
Max. Inlet Vacuum	5 in. Hg
Max. Case Pressure	25 psi
Relief Valve Pressure (set at)	3600 psi
13-729 Hydraulic Valve (2 bank)	1500 psi
13-730 Hydraulic Valve (3 bank)	1500 psi

HYDRAULIC DIAGRAM

REF#	PART#	DESCRIPTION	QUANTITY
1	13-032	Wheel Motor (3WD only)	1
2	13-424	Hydraulic Hose (63 ¹ / ₄ long)(3WD only)	1
	8840-62	Flex Guard Loom (3WD only)	1
3	13-425	Hydraulic Hose (70 ¹ / ₄ long)(3WD only)	1
	8840-69	Flex Guard Loom (3WD only)	
4	13-409	On - Off Valve (3WD only)	1
	18-174	Elbow 1/2 Straight Thread	2
	18-228	Hollow Hex Plug	2
	18-266	Elbow 45°	2
5	13-587	Hydraulic Hose (16" long)	1
6	13-584	Oil Tank	1
	13-586	Filler Breather	1
7	8917-14.5	Suction Hose 5/8	1
	18-040	Hose Clamp	2
8	13-616	Hydraulic Hose (29" long)	1
9	8917-38	Suction Hose 5/8	1
	18-040	Hose Clamp	2
10	13-110	Hydrostatic Pump	1
11	23-006	Oil Filter	1
	23-031	Replacement Filter Only	
12	8917-10	Suction Hose 5/8	1
	18-040	Hose Clamp	2
13	13-698	Hydraulic Hose (39" long)	1
14	13-617	Hydraulic Hose (25" long)	1
15	13-615	Wheel Motor	2
16	13-612	Hydraulic Tube	2
17	23-172	Oil Cooler	1
18	13-633	Hydraulic Hose (19 ¹ / ₂ " long) (3WD only)	2
	18-264	Cap (2 WD only)	2
19	18-164	Hydraulic Hose (16" long)	2
20	13-292	Hydraulic Cylinder	1
21	13-357	Hydraulic Cylinder	1
22	13-552	Hydraulic Hose (21 ¹ / ₄ long)	1
23	13-549	Hydraulic Hose (24 ¹ / ₈ long)	1
24	76-105	Hydraulic Hose (17 ¹ / ₂ long)	1
25	13-729	2-Bank Hydraulic Valve	1
	78-418	Bent Handle	1 per bank
	13-730	3-Bank Hydraulic Valve	
26	60-368	Hydraulic Hose (59 ¹ / ₄ long)	1
27	13-406	Hydraulic Cylinder	1
28	13-444	Hydraulic Hose (50 long)	1

WIRING SCHEMATIC

Diagrams

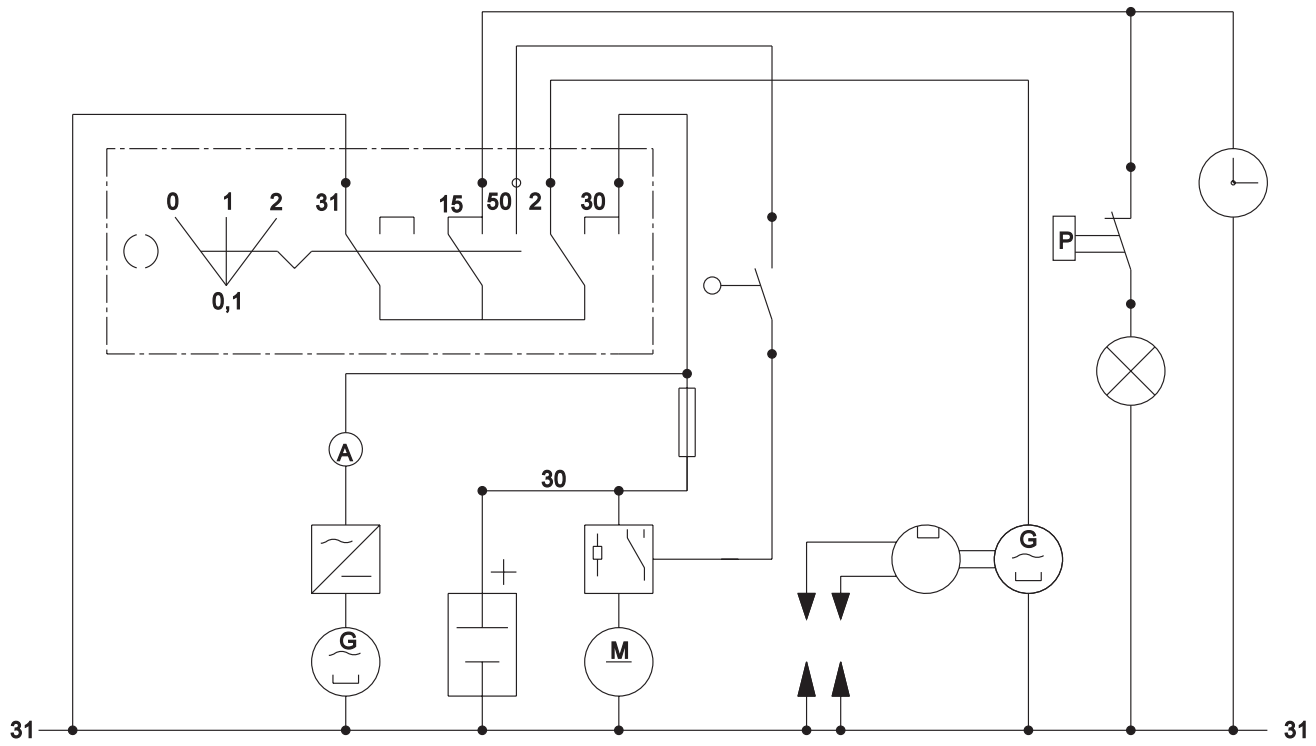

0		31	15	2
1			15	30
2			50	30

HYDRAULIC SCHEMATIC 2 WHEEL DRIVE

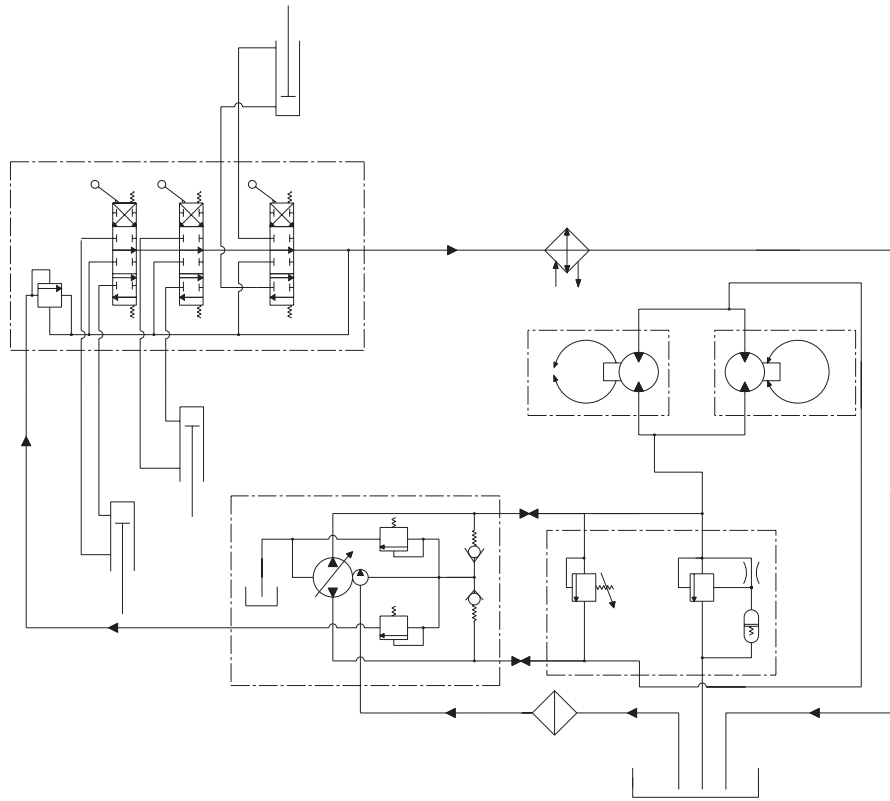

HYDRAULIC SCHEMATIC 3 WHEEL DRIVE

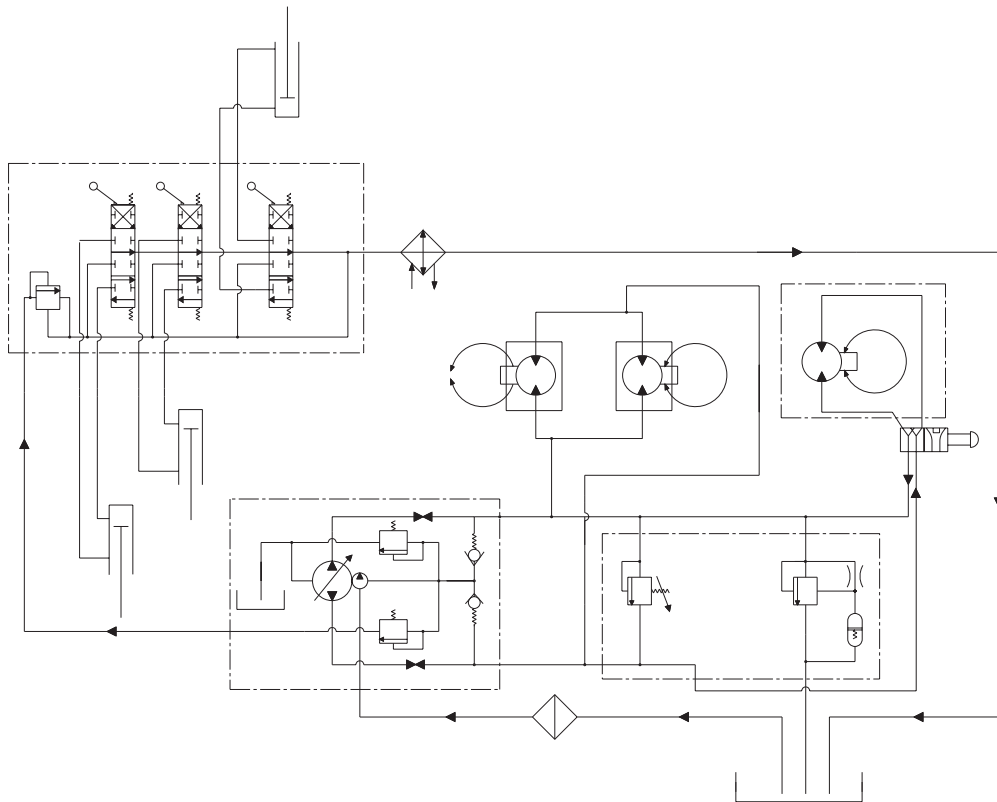

MAINFRAME DRAWING

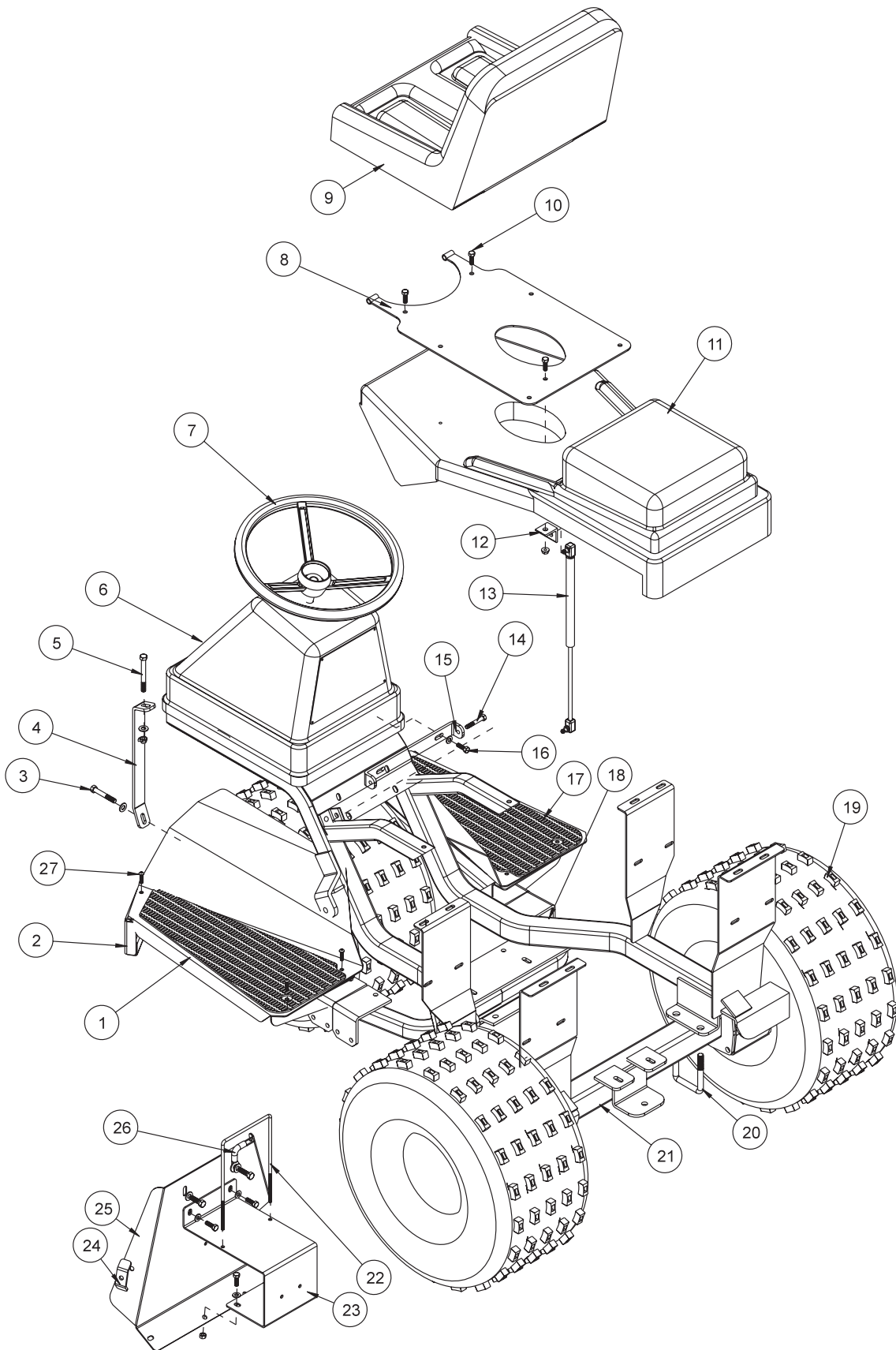

Parts

MAINFRAME PARTSLIST

REF#	PART#	DESCRIPTION	QUANTITY
1	13-712	Left Floor Board	1
	13-717	Left Rubber Mat	1
2	13-713	Front Bumper	1
3	HB-38-16-250	Bolt $\frac{3}{8}$ - 16 x 2 $\frac{1}{2}$	2
	HW-38	Washer $\frac{3}{8}$	2
	HNTL-38-16	Lock Nut $\frac{3}{8}$ - 16	2
4	13-208	Bumper Brace	2
5	HB-38-16-350	Bolt $\frac{3}{8}$ - 16 x 3 $\frac{1}{2}$	2
	HW-38	Washer $\frac{3}{8}$	2
	HNTL-38-16	Lock Nut $\frac{3}{8}$ - 16	2
6	13-692	Console	1
	HSDPS-14-100	SS Pan Head Drill Screw $\frac{1}{4}$ x 1	4
7	20-057	Steering Wheel	1
	20-129	Center Cap	1
8	13-703	Seat Bracket	1
9	14-269	Adjustable Seat	1
	13-398	Adjuster Set with 9" Handle	1
	HNFL-516-18	Flange Whiz-Lock Nut $\frac{5}{16}$ - 18	4
10	HB-516-18-100	Bolt $\frac{5}{16}$ - 18 x 1	3
	HNFL-516-18	Whiz Lock Nut $\frac{5}{16}$ - 18	3
11	13-693	Rear Hood	1
	78-384	Latch	2
	HRS-316-1125	Pop Rivet $\frac{3}{16}$ x 1 $\frac{1}{8}$	6
12	13-570	Bracket	1
13	13-569	Gas Spring 60#	1
	26-034	Ball Stud	2
	HWL-516	Lockwasher $\frac{5}{16}$	2
	HN-516-18	Nut $\frac{5}{16}$ - 18	2
14	HB-516-18-200	Bolt $\frac{5}{16}$ - 18 x 2	2
	HNTL-516-18	Lock Nut $\frac{5}{16}$ x 18	2
15	13-016	Seat Hinge	1
16	HB-516-18-100	Bolt $\frac{5}{16}$ - 18 x 1	2
	HN-516-18	Nut $\frac{5}{16}$ - 18	2
	HW-516	Washer $\frac{5}{16}$	4
	HWL-516	Lockwasher $\frac{5}{16}$	2
17	13-711	Right Floor Board	1
	13-716	Right Rubber Mat	1
18	13-708	Main Frame	1
19	13-611	Tire and Wheel	2
	13-611-01	Tire 22 x 11.00 x 8 Turf Tamer	2
	13-610-02	Wheel	2
	60-268	Lug Bolt $\frac{1}{2}$ - 20 x 1 $\frac{5}{16}$	10
20	13-118	U-Bolt	2
21	13-705	Axle	1
	HWL-12	Lockwasher $\frac{1}{2}$	4
	HN-12-20	Nut $\frac{1}{2}$ - 20	4

(Continued on next page)

MAINFRAME DRAWING

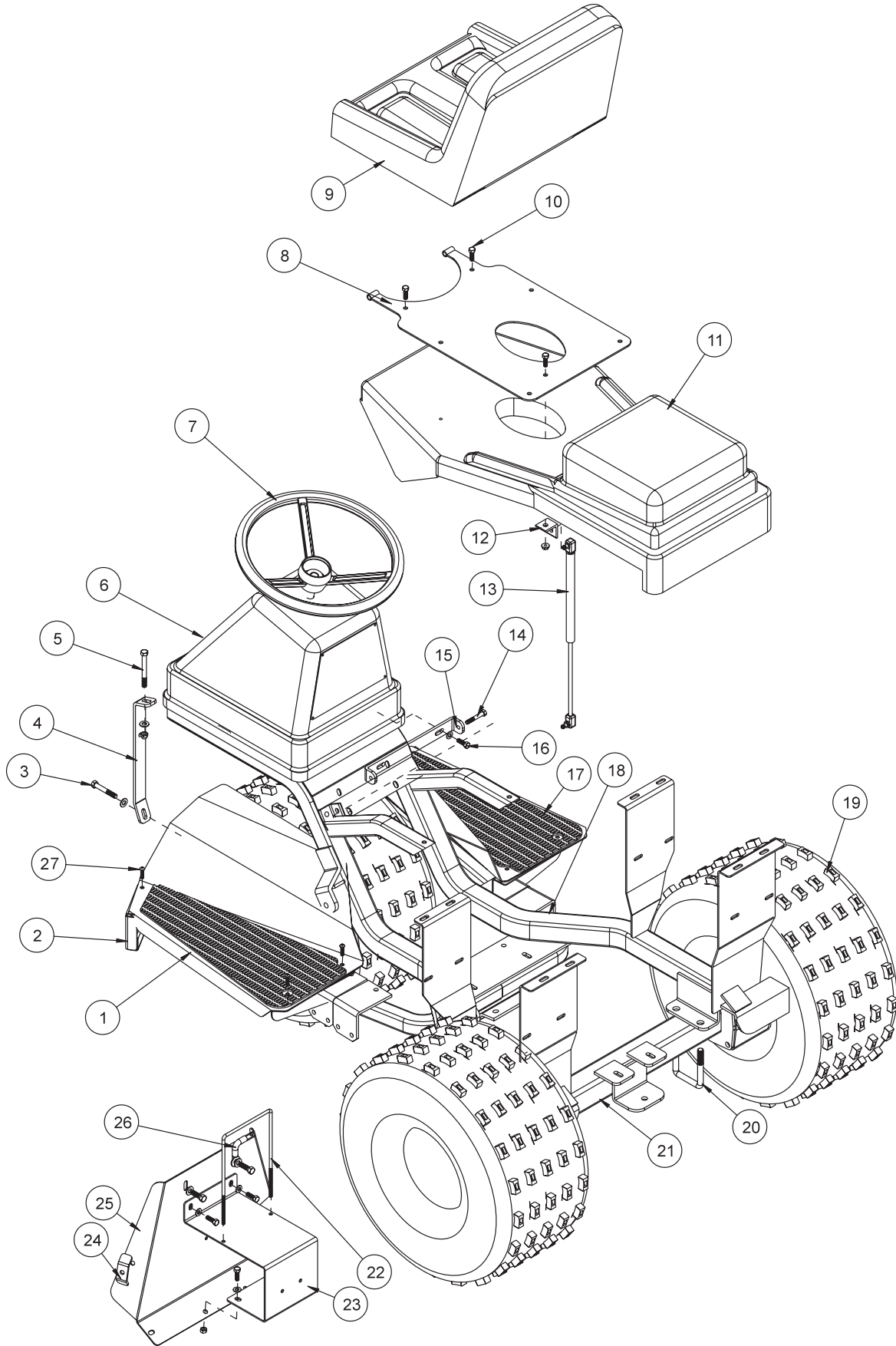

Parts

MAINFRAME PARTSLIST

REF#	PART#	DESCRIPTION	QUANTITY
22	13-214	Battery Hold Down	1
	8900-6	Flex Guard Loom $1/4$	1
	HWL-14	Lockwasher $1/4$	2
	HNW-14-20	Wing Nut $1/4$ - 20	2
23	13-213	Battery Box	1
	HB-516-18-100	Bolt $5/16$ - 18 x 1	4
	HW-516	Washer $5/16$	6
	HNTL-516-18	Lock Nut $5/16$ - 18	4
24	13-099	Hose Clamp (3WD Only)	1
	HB-38-16-175	Bolt $3/8$ - 16 x $1\ 3/4$	1
	HNTL-38-16	Lock Nut $3/8$ - 16	1
25	13-218	Mud Guard	1
	HB-38-16-125	Bolt $3/8$ - 16 x $1\ 1/4$	3
	HW-38	Washer $3/8$	4
	HNTL-38-16	Lock Nut $3/8$ - 16	3
26	22-054	Battery Cable	1
	HB-38-16-125	Bolt $3/8$ - 16 x $1\ 1/4$	1
	HW-38	Washer $3/8$	1
	HWL-38	Lock Washer $3/8$	1
	HN-38-16	Nut $3/8$ - 16	1
	HST-516-18-100	Truss Head Screw $5/16$ - 18 x 1	3
27	HW-516	Washer $5/16$	3
	HNTL-516-18	Lock Nut $5/16$ - 18	3

ACCELERATOR LINKAGE DRAWING

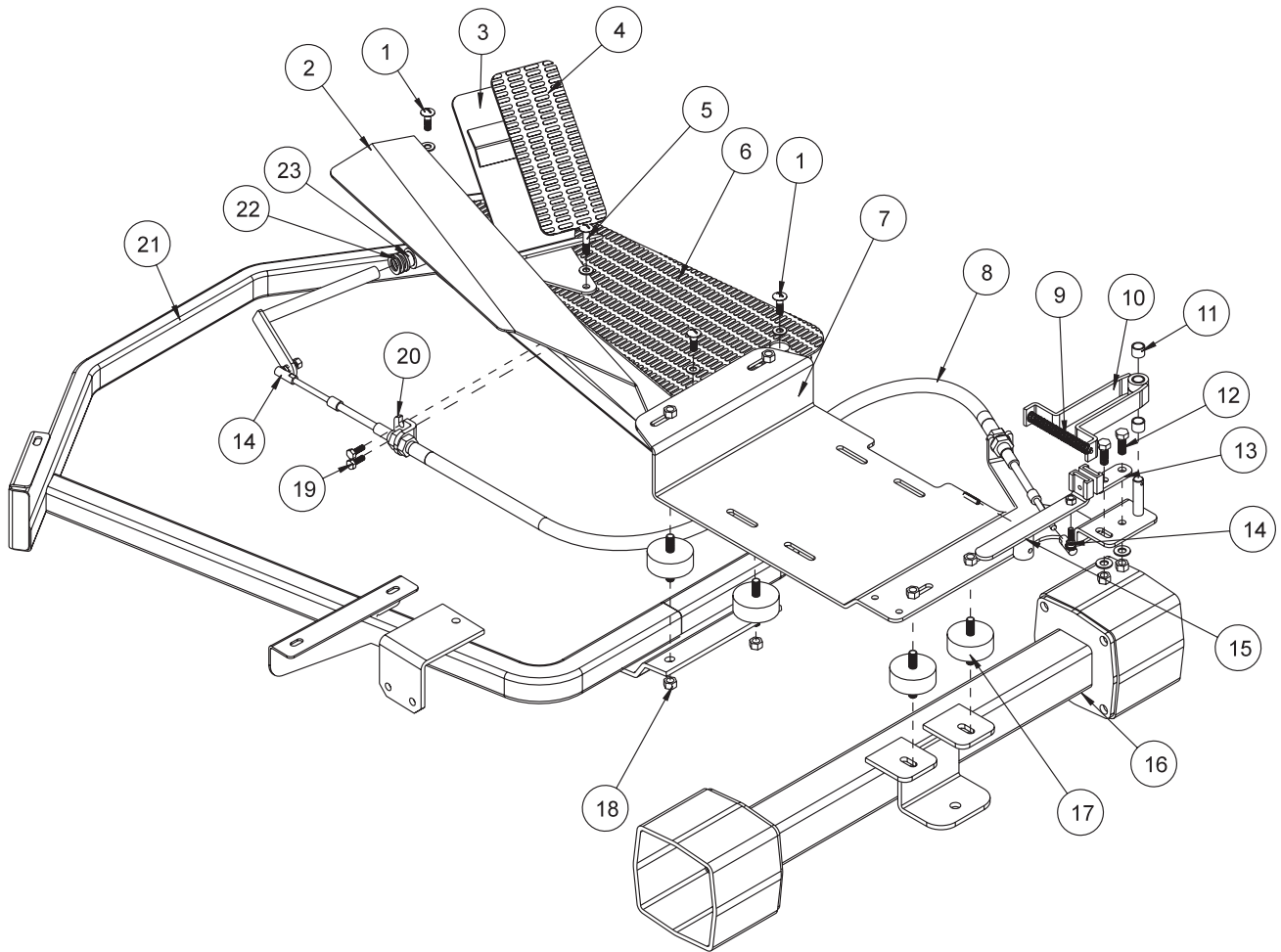

Parts

ACCELERATOR LINKAGE PARTS LIST

REF#	PART#	DESCRIPTION	QUANTITY
1	HST-516-18-100	Truss Head Screw ⁵ / ₁₆ - 18 x 1	3
	HW-516	Washer ⁵ / ₁₆	3
	HNTL-516-18	Lock Nut ⁵ / ₁₆ -18	3
2	13-711	Right Floor Board	1
3	13-709	Foot Pedal	1
4	13-715	Rubber Mat (part of 13-709)	1
5	HST-516-18-150	Truss Head Screw ⁵ / ₁₆ - 18 x 1 ¹ / ₂	3
	HW-516	Washer ⁵ / ₁₆	3
	HNTL-516-18	Lock Nut ⁵ / ₁₆ -18	3
6	13-716	Right Rubber Mat	1
7	13-706	Engine Frame	1
8	13-632	Push Pull Cable	1
9	11-050	Extension Spring	1
10	34-038	Centering Arm with Bushing	2
11	18-234	Bushing (part of 34-038)	2
12	HB-38-16-100	Bolt ³ / ₈ - 16 x 1	2
	HW-38	Washer ³ / ₈	2
	HNTL-38-16	Lock Nut ³ / ₈ - 16	2
13	13-624	Stop with Plastic Wear Strip	1
	8946-1	Wear Strip (part of 13-624)	1
	HRS-316-050	Steel Rivet ³ / ₁₆ x ¹ / ₂ (part of 13-624)	1
14	18-115	Ball Joint ¹ / ₄ - 28	2
	HWL-14	Lockwasher ¹ / ₄	2
	HN-14-28	Nut ¹ / ₄ - 28	4
15	13-704	Shift Arm with Plastic Wear Strip	1
	8946-1.5	Wear Strip (part of 13-704)	1
	HRS-316-050	Rivet ³ / ₁₆ x ¹ / ₂ (part of 13-704)	1
16	13-705	Axle Assembly	1
17	11-021	Rubber Engine Mount	4
	HWL-38	Lockwasher ³ / ₈	8
18	HN-38-24	Nut ³ / ₈ - 24	8
19	HB-14-20-075	Bolt ¹ / ₂ -20 x ³ / ₄	2
	HNTL-14-20	Lock Nut ¹ / ₄ - 20	2
20	13-674	Cable Bracket	1
21	13-713	Front Bumper	1
22	HMB-58-14	Machine Bushing 14 GA x ⁵ / ₈ (part of 13-709)	3
23	76-128	Flange Bushing (part of 13-709)	2

RIGHT FENDER AND ENGINE DRAWING

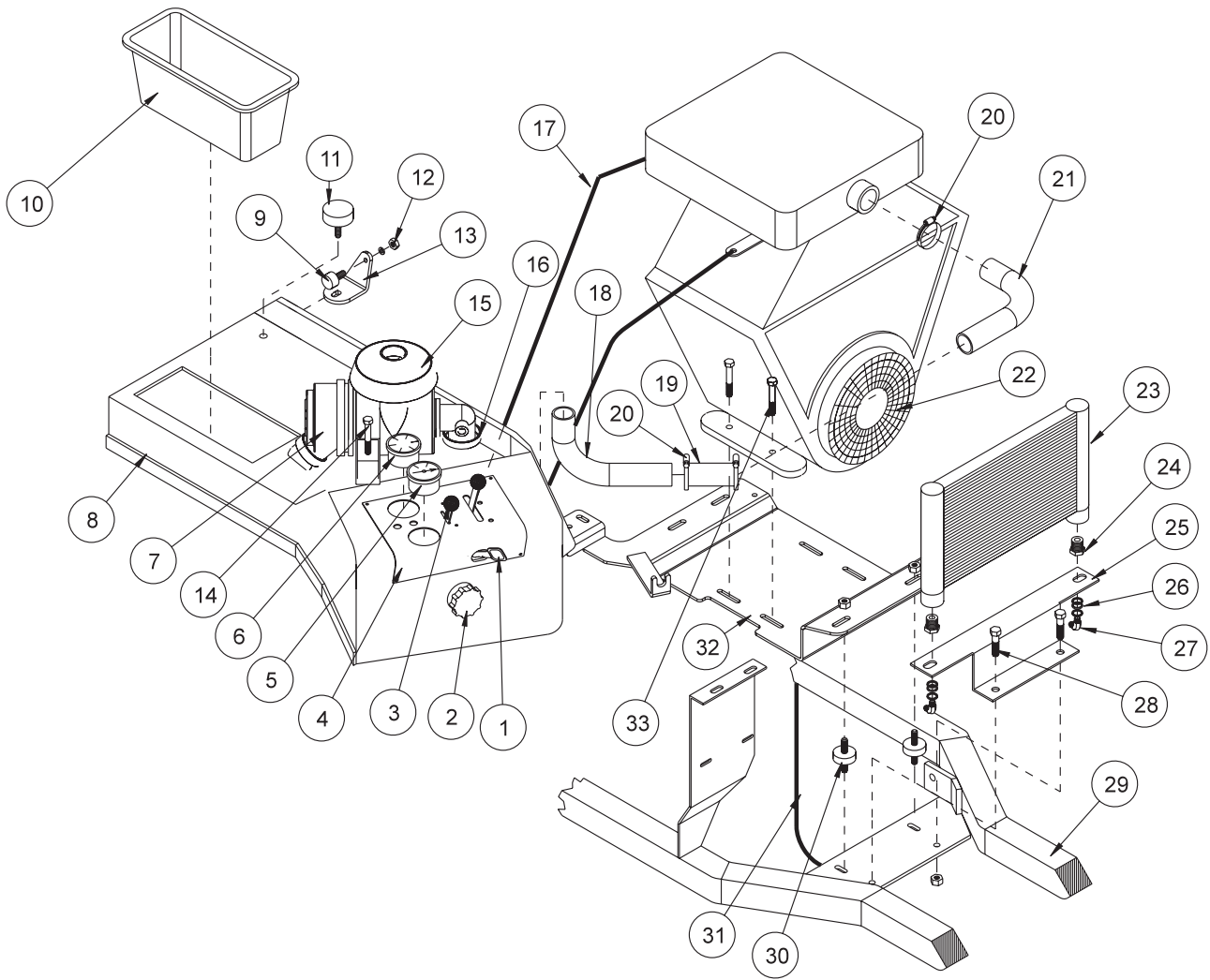

Parts

RIGHT FENDER AND ENGINE PARTS LIST

REF#	PART#	DESCRIPTION	QUANTITY
1	13-488	Ignition Key with Switch	1
2	13-409	On-Off Valve 3WD to 2WD (3WD only)	1
3	13-290	Choke Control with Cable	1
4	13-566	Instrument Panel	1
	13-640	Instrument Panel Decal	1
	HSA-8-075	Tapping Screw #8 x 3/4	4
5	22-003	Ammeter	1
	HN-10-32	Nut #10 - 32	1
	HWL-10	Lockwasher #10	1
6	12-017	Hour Meter	1
	HN-10-32	Nut #10 - 32	1
	HWL-10	Lockwasher #10	1
7	42-076	Air Cleaner with Element	1
	42-076-03	Filter Element (Replacement-part of 42-076)	1
8	13-593	Right Fender	1
9	15-013	Rubber Bumper	1
10	13-583	Trash Bucket	1
11	50-081	Rubber Insulator	1
12	HWL-14	Lockwasher 1/4	1
	HN-14-20	Nut 1/4 - 20	1
13	13-724	Right Hood Support	1
14	42-076-01	Mounting Band	1
	HB-14-20-175	Bolt 1/4 - 20 x 1 3/4	2
	HW-14	Washer 1/4	2
	HNTL-14-20	Lock Nut 1/4 - 20	2
15	42-076-02	Air Inlet Cap	1
16	18-123	Hose Clamp #32 1 9/16 - 2 1/2	1
17	34-160	Throttle Control with Cable	1
	34-162	Throttle Bracket	1
	HSM-10-32-063	Machine Screw #10 - 32 x 5/8	4
	HWL-10	Lockwasher #10	4
	HN-10-32	Nut #10 - 32	4
	HSTP-14-20-075	Phillips Truss Machine Screw 1/4 - 20 x 3/4	2
	HWL-14	Lockwasher 1/4	2
	HN-14-20	Nut 1/4 - 20	2
	34-163	Cable Bracket	1
	HN-38-24	Nut 3/8 - 24	2
18	27-113	Rubber Elbow	1
19	42-776	Air Tube	1
20	18-116	Hose Clamp #24 1 1/16 - 2	3
21	13-609	Rubber Hose	1
22	15-165	Engine Briggs and Stratton 16 HP	1
	15-165-01	Air Filter Element with Pre-Cleaner	1
	13-531	Engine Oil Filter	1
	13-518	Carburetor to Air Cleaner Gasket	1
	13-491	Oil Switch	1
	13-524	Blow Plug	1

(Continued on next page)

RIGHT FENDER AND ENGINE DRAWING

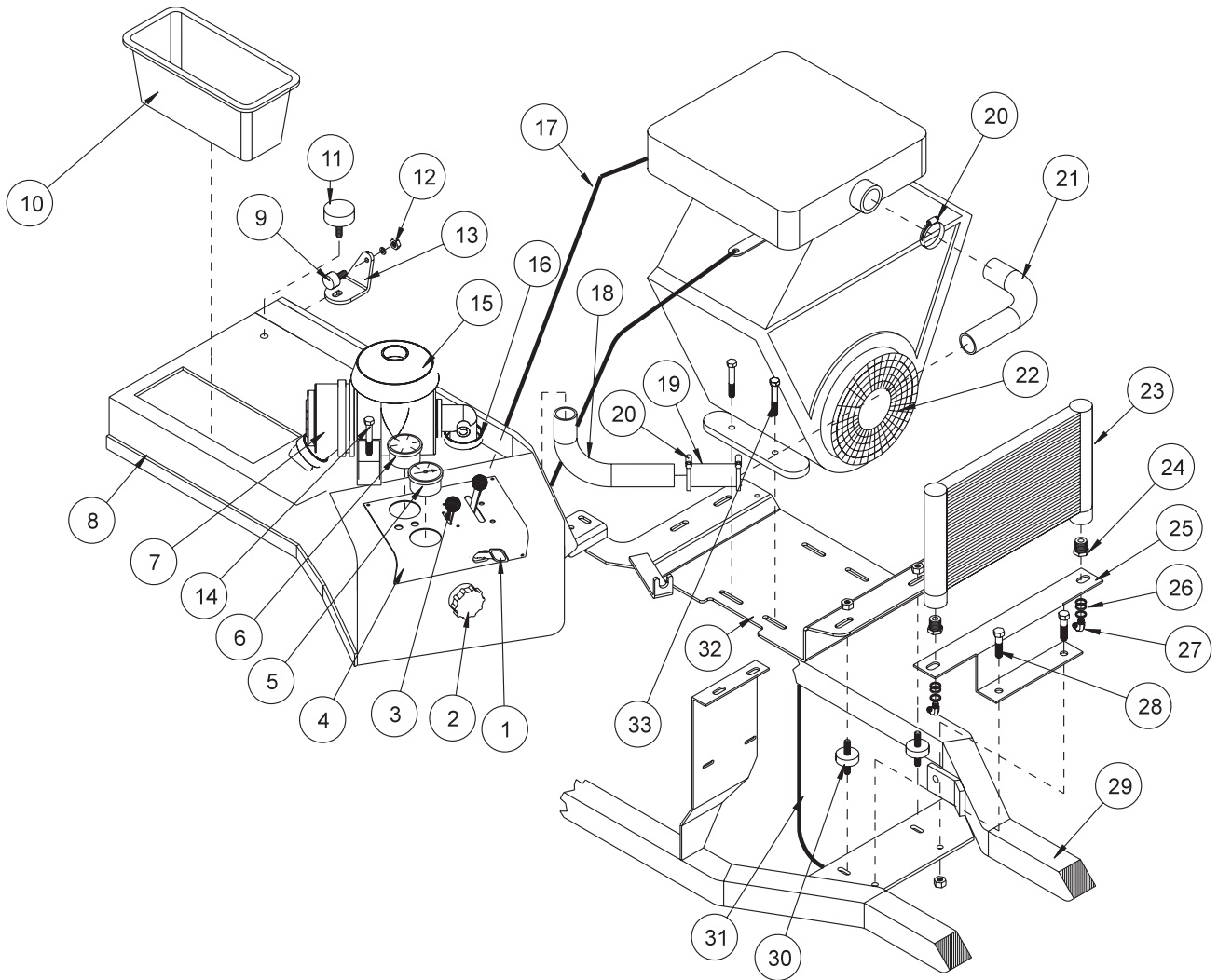

Parts

RIGHT FENDER AND ENGINE PARTS LIST

REF#	PART#	DESCRIPTION	QUANTITY
23	23-172	Oil Cooler	1
24	18-015	Pipe Thread Reducer $1/2 \times 1/4$	2
25	13-004	Cooler Bracket	1
26	HMB-916-14	Machine Bushing $9/16 \times 14GA$	6
27	23-140	Elbow	2
28	HB-716-14-150	Bolt $7/16 - 14 \times 1 1/2$	2
	HNTL-716-14	Top Lock Nut $7/16 - 14$	2
29		Main Frame	1
30	11-021	Rubber Engine Mount	2
	HW-38	Washer $3/8$	2
	HWL-38	Lockwasher $3/8$	4
	HN-38-24	Nut $3/8 - 24$	4
31	22-017	Ground Cable	1
32	13-706	Engine Frame	1
33	HB-516-18-175	Bolt $5/16 - 18 \times 1 3/4$	4
	HNTL-516-18	Lock Nut $5/16 - 18$	4
NS	13-603	Air Cleaner Base	1

LEFT FENDER AND TANK DRAWING

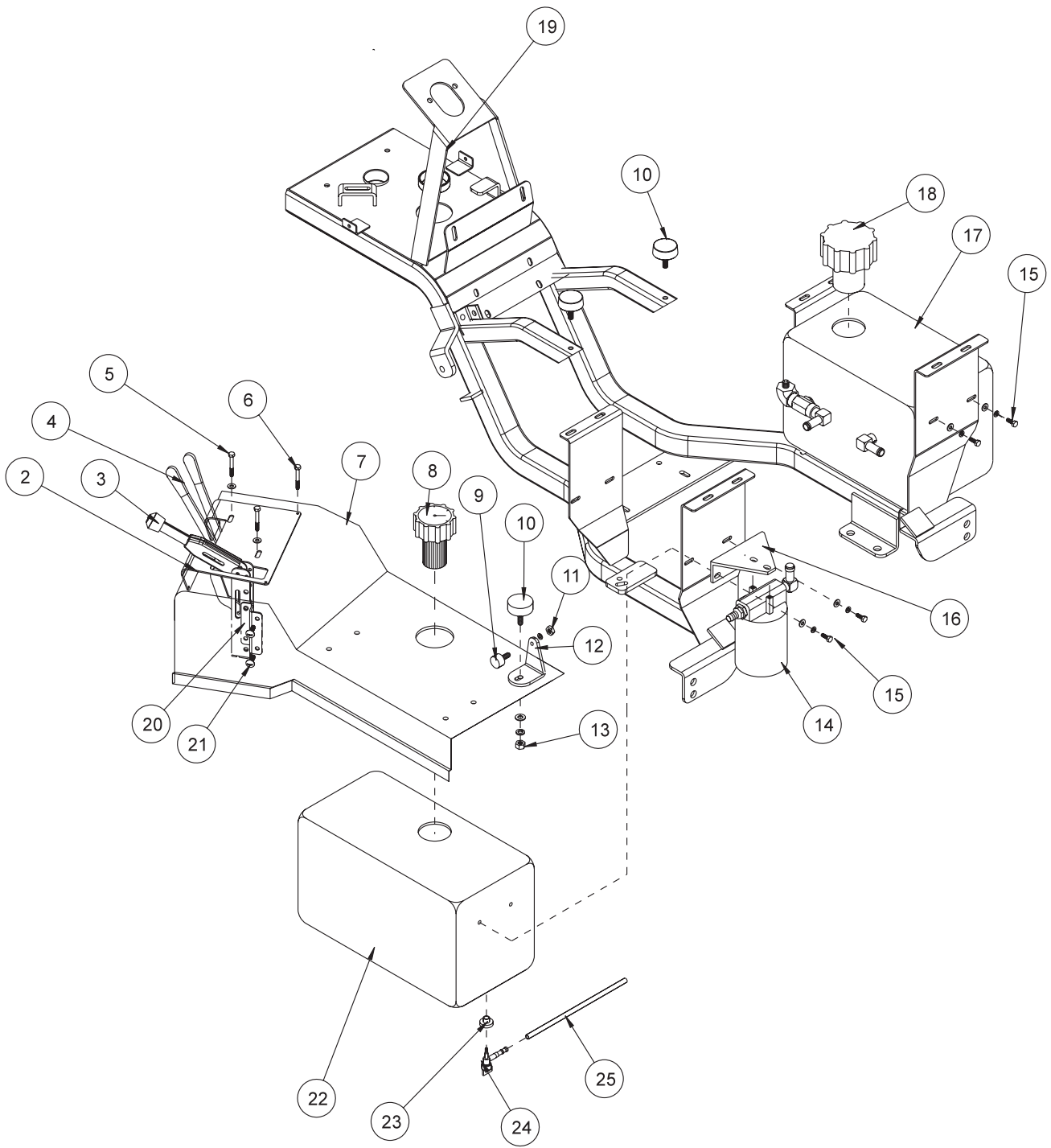

Parts

LEFT FENDER AND TANK PARTS LIST

REF#	PART#	DESCRIPTION	QUANTITY
2	13-694	Valve Cover	1
	13-695	Valve Cover Decal	1
3	10-120	Park Brake	1
4	13-729	Hydraulic Valve	1
	78-418	Valve Handle	2
5	HB-14-20-200	Bolt $\frac{1}{4}$ - 20 x 2	2
	HW-14	Washer $\frac{1}{4}$	2
	HWL-14	Lockwasher $\frac{1}{4}$	2
	HN-14-20	Nut $\frac{1}{4}$ - 20	2
6	HSA-8-075	Tapping Screw #8 x $\frac{3}{4}$	4
7	13-594	Left Fender	1
8	13-588	Gas Gauge and Cap (comes with tank)	1
9	15-013	Rubber Bumper	1
10	50-081	Rubber Insulator	3
11	HW-14	Lockwasher $\frac{1}{4}$	1
	HN-14-20	Nut $\frac{1}{4}$ - 20	1
12	13-725	Left Hood Support	1
13	HW-38	Washer $\frac{3}{8}$	3
	HWL-38	Lockwasher $\frac{3}{8}$	3
	HN-38-16	Nut $\frac{3}{8}$ - 16	3
14	23-006	Hydraulic Oil Filter	1
	23-031	Hydraulic Filter Element	1
15	HB-14-20-075	Bolt $\frac{1}{4}$ - 20 x $\frac{3}{4}$	4
	HWL-14	Lockwasher $\frac{1}{4}$	4
	HW-14	Washer $\frac{1}{4}$	4
16	13-217	Oil Filter Bracket	1
17	13-584	Oil Tank	1
18	13-586	Filler Breather	1
	13-586-01	Cap Gasket	1
	13-586-02	Bottom Gasket	2
19	13-708	Main Frame	1
20	13-702	Park Brake Mount	1
	HB-516-18-150	Bolt $\frac{5}{16}$ - 18 x $1\frac{1}{2}$	2
	HNTL-516-18	Lock Nut $\frac{5}{16}$ - 18	2
21	HST-516-18-100	Truss Head Screw $\frac{5}{16}$ - 18 x 1	2
	HNTL-516-18	Lock Nut $\frac{5}{16}$ - 18	2
22	13-585	Gas Tank with Cap	1
23	26-054	Bushing Insert	1
24	26-055	Shut Off Valve	1
25	8800-12	Fuel Hose $\frac{1}{4}$ x $11\frac{1}{2}$	1
	18-186	Hose Clamp	2

TWO WHEEL DRIVE FRONT FORK DRAWING

Parts

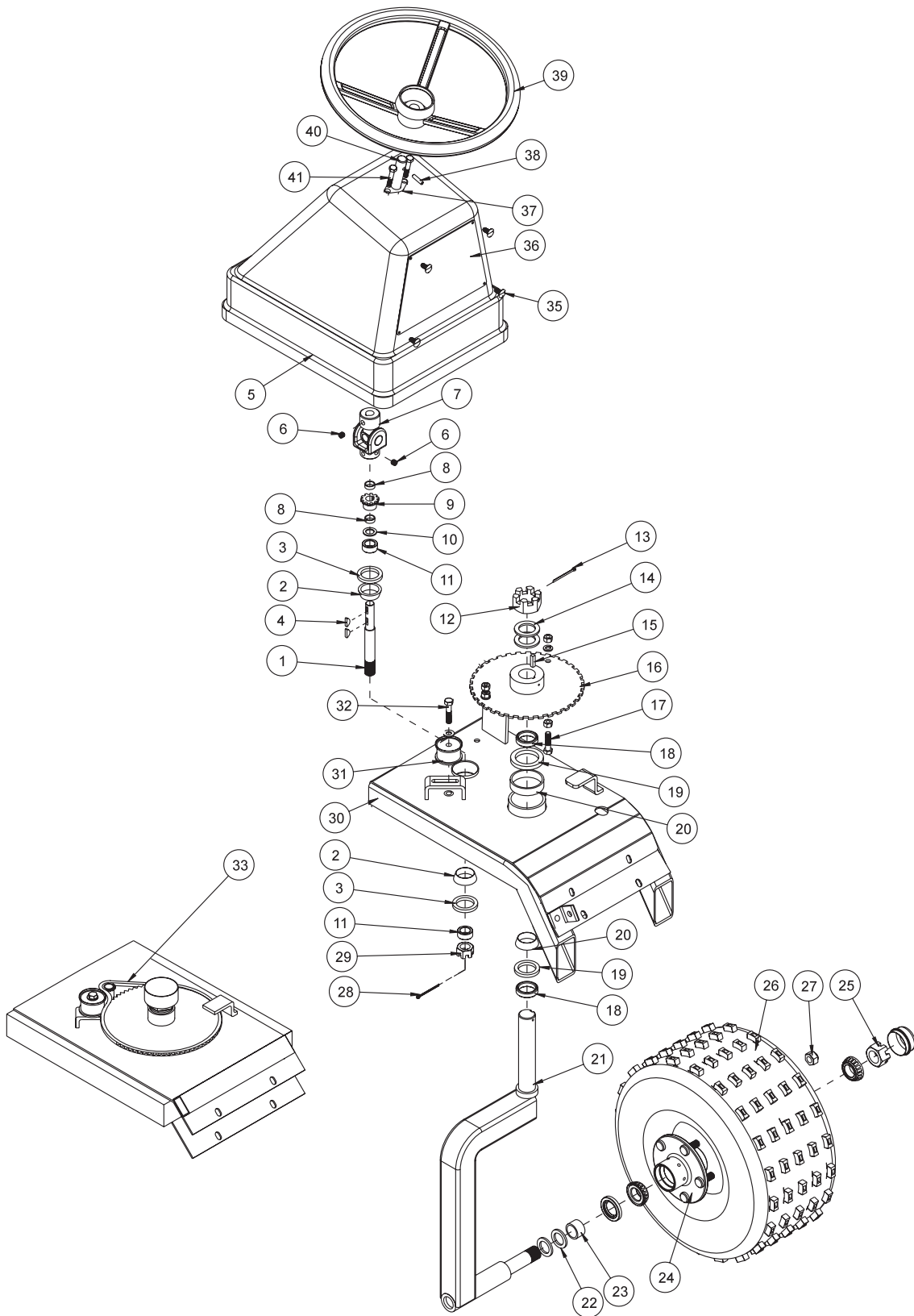

TWO WHEEL DRIVE FRONT FORK PARTSLIST

REF#	PART#	DESCRIPTION	QUANTITY
1	13-005	Bottom Steering Shaft	1
2	11-038	Bearing	2
3	11-039	Oil Seal	2
4	HWK-316-063	Woodruff Key $3/16 \times 5/8$	2
5	13-692	Console	1
6	HSSHS-516-18-038	Set Screw $5/16 - 18 \times 3/8$	4
7	60-300	U-Joint	1
8	60-325	Spacer	2
9	60-298	Sprocket	1
10	HMB-58-14	Machine Bushing $5/8 \times 14GA$	1
11	11-040	Spacer	3
12	HNAJ-114-12	Slotted Jam Nut $1 1/4 - 12$	1
13	HP-18-200	Cotter Pin $1/8 \times 2$	1
14	HMB-114-10	Machine Bushing	2
15	HKSQ-14-100	Machine Key $1/4 \times 1/4 \times 1$	1
16	13-039	Steering Sprocket	1
17	HB-38-16-150	Bolt $3/8 - 16 \times 1 1/2$	2
	HWL-38	Lockwasher $3/8$	2
	HN-38-16	Nut $3/8 - 16$	4
18	20-141	Spacer	2
19	20-142	Oil Seal	2
20	20-143	Bearing	2
21	13-448	Front Fork	1
23	11-042	Spacer	1
24	80-019	Hub (Includes Bearings, Seal, Dust Cap and Lug Nuts)	1
	11-041	Seal (part of 80-019)	1
	80-167	Dust Cap (part of 80-019)	1
25	HNA-100-14	Jam Nut 1 - 14	1
	HP-18-150	Cotter Pin $1/8 \times 1 1/2$	1
26	11-175	Tire and Wheel (front tire fluid filled to 60lbs. total)	1
	13-611-01	Tire 22 x 11.00 x 8 Turf Tamer	1
	11-005-02	Wheel	1
	8839	Windshield Washer Fluid or Equivalent	34.5 pints
27	HNL-12-20	Lug Nut $1/2 - 20$ (part of 80-019)	5
28	HP-18-150	Cotter Pin $1/8 \times 1 1/2$	1
29	HNAT-34-16	Slotted Nut	1
30		Part of Main Frame	
31	26-060	Idler Pulley	1
32	HB-38-16-175	Bolt $3/8 - 16 \times 1 3/4$	1
	HW-38	Washer $3/8$	As Required
	HWL-38	Lockwasher $3/8$	1
	HN-38-16	Nut $3/8 - 16$	1
33	13-040	Roller Chain #35	1
	18-114	Connecting Link #35	1
	18-143	Offset Link #35	As Required
35	HSA-8-075	Tapping Screw #8 x $3/4$	4
36	13-714	Console Cover	1
	13-063	Warning Decal	1
37	40-009	Flange Bearing	1
38	HRP-14-200	Roll Pin	1
39	20-057	Steering Wheel	1
	HSSHS-516-18-050	Set Screw $5/16 - 18 \times 1/2$	1
	20-129	Center Cap	1
40	13-707	Top Steering Shaft	1
	HWK-316-075	Woodruff Key $3/16 \times 3/4$	1
41	HB-516-18-175	Bolt $5/16 - 18 \times 1 3/4$	2
	HNTL-516-18	Lock Nut $5/16 \times 18$	2

THREE WHEEL DRIVE FRONT FORK DRAWING

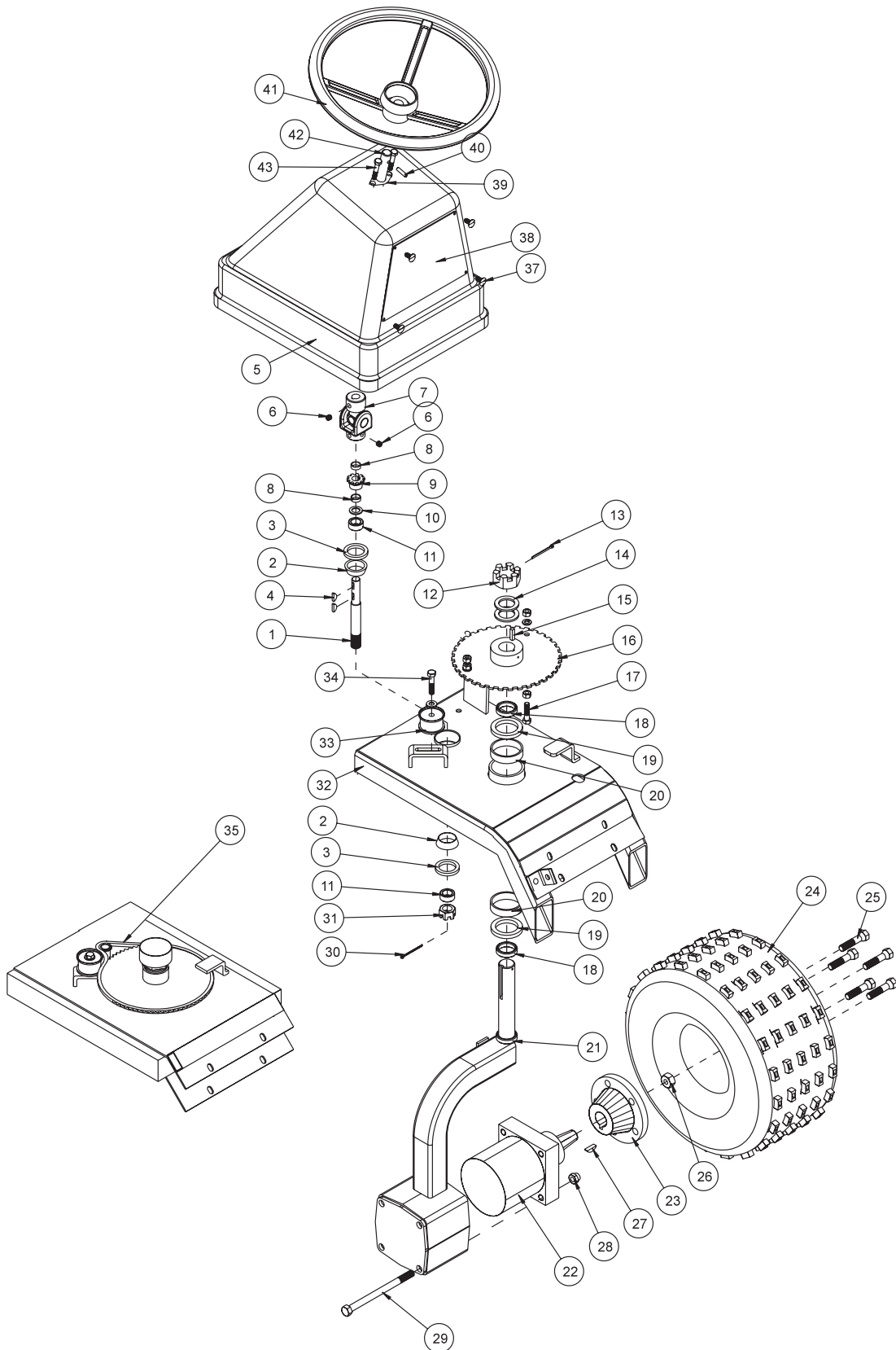

Parts

THREE WHEEL DRIVE FRONT FORK PARTS LIST

REF#	PART#	DESCRIPTION	QUANTITY
1	13-005	Bottom Steering Shaft	1
2	11-038	Bearing	2
3	11-039	Oil Seal	2
4	HWK-316-063	Woodruff Key $\frac{3}{16} \times \frac{5}{8}$	2
5	13-692	Console	1
6	HSSHS-516-18-038	Set Screw $\frac{5}{16} - 18 \times \frac{3}{8}$	4
7	60-300	U-Joint	1
8	60-325	Spacer	2
9	60-298	Sprocket	1
10	HMB-58-14	Machine Bushing $\frac{5}{8} \times 14GA$	1
11	11-040	Spacer	3
12	HNAT-114-12	Thick Slotted Jam Nut $1\frac{1}{4} - 12$	1
13	HP-18-200	Cotter Pin $\frac{1}{8} \times 2$	1
14	HBM-114-10	Machine Bushing	2
15	HKSQ-14-100	Machine Key $\frac{1}{4} \times \frac{1}{4} \times 1$	1
16	13-039	Steering Sprocket	1
17	HB-38-16-150	Bolt $\frac{3}{8} - 16 \times 1\frac{1}{2}$	2
	HWL-38	Lockwasher $\frac{3}{8} - 16$	2
	HN-38-16	Nut $\frac{3}{8} - 16$	4
18	20-141	Spacer	2
19	20-142	Oil Seal	2
20	20-143	Bearing	2
21	13-130	Front Fork	1
	13-652	Hose Clamp (part of 13-130)	1
22	13-032	Wheel Motor	1
	18-350	Seal Loc 90° Elbow	2
23	13-033	Hub	1
24	11-175	Tire and Wheel (front tire fluid filled to 60lbs. total)	1
	13-611-01	Tire 22 x 11.00 x 8 Turf Tamer	1
	11-005-02	Wheel	1
	8839	Windshield Washer Fluid or Equivalent	34.5 pints
25	60-268	Lug Bolt $\frac{1}{2} - 20 \times 1\frac{5}{16}$	5
26	14-265	Nut 1 - 20 (part of 13-032)	1
27	HWK-516-100	Woodruff Key $\frac{5}{16} \times 1$ (part of 13-032)	1
28	HNTL-12-13	Lock Nut $\frac{1}{2} - 13$	4
29	HB-12-13-700	Bolt $\frac{1}{2} - 13 \times 7$	4
30	HP-18-150	Cotter Pin $\frac{1}{8} \times 1\frac{1}{2}$	1
31	HNAT-34-16	Slotted Nut $\frac{3}{4} - 16$	1
32		Part of Main Frame	
33	26-060	Idler Pulley	1
34	HB-38-16-175	Bolt $\frac{3}{8} - 16 \times 1\frac{3}{4}$	1
	HW-38	Washer $\frac{3}{8}$	As Required
	HWL-38	Lockwasher $\frac{3}{8}$	1
	HN-38-16	Nut $\frac{3}{8} - 16$	1
35	8834-30	Roller Chain #35	1
	18-114	Connecting Link #35	1
	18-143	Offset Link #35	As Required
37	HSA-8-075	Tapping Screw #8 x $\frac{3}{4}$	4
38	13-714	Console Cover	1
	13-063	Warning Decal	1
39	40-009	Flange Bearing	1
40	HRP-14-200	Roll Pin	1
41	20-057	Steering Wheel	1
	HSSHS-516-18-050	Set Screw $\frac{5}{16} - 18 \times \frac{1}{2}$	1
	20-129	Center Cap	1
42	13-707	Top Steering Shaft	1
	HWK-316-075	Woodruff Key $\frac{3}{16} \times \frac{3}{4}$	1
43	HB-516-18-175	Bolt $\frac{5}{16} - 18 \times 1\frac{3}{4}$	2
	HNTL-516-18	Lock Nut $\frac{5}{16} \times 18$	2

ENGINE AND PUMP DRAWING

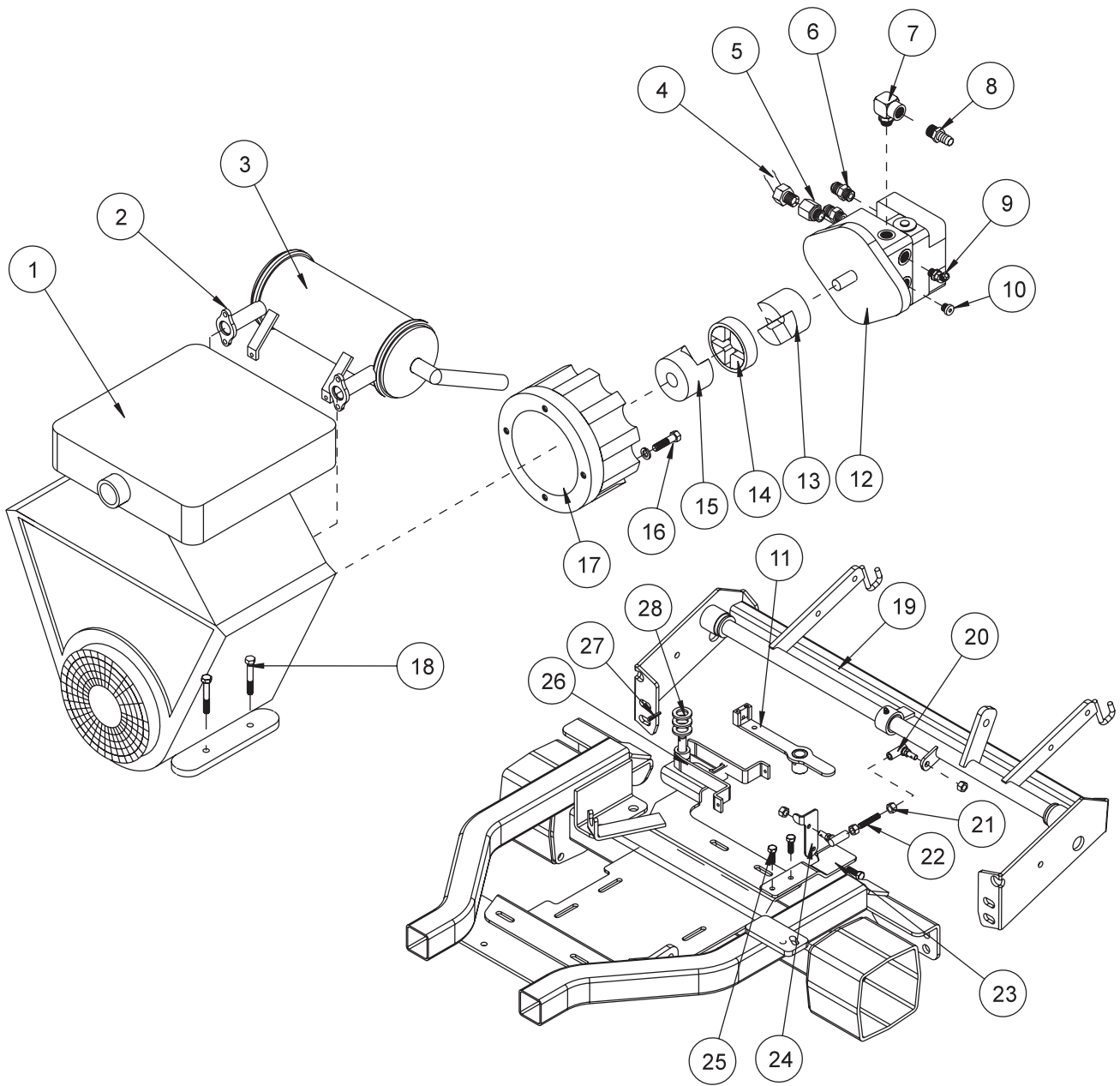

Parts

ENGINE AND PUMP PARTS LIST

REF#	PART#	DESCRIPTION	QUANTITY
1	15-165	Engine Briggs and Stratton 16 HP	1
2	13-532	Exhaust Port to Muffler Gasket	2
	HSSH-8-1.25-25	Socket Head Set Screw M8 x 1.25 x 25	4
	HWLM-8	Metric Lockwasher M8	4
3	27-123	Muffler	1
4	23-076	O-Ring Adapter	1
5	23-143	Connector	1
6	18-267	Straight Thread Connector	2
7	23-130	Elbow	1
8	23-139	Barb Fitting	1
9	18-188	Elbow 45°	1
10	23-126	O-ring Plug	1
11	13-704	Shift Arm	1
	HRP-14-100	Roll Pin 1/4 x 1	1
12	13-110	Variable Pump (Right Rotation)	1
	HHP-18	Bridge Pin 1/8	1
	HSSH-12-13-175	Socket Screw 1/2 - 13 x 1 3/4	2
	HWL-12	Lockwasher 1/2	2
13*	13-665	Steel Coupler Half #4 3/4" Bore	1
	HSSH-716-14-075	Socket Head Set Screw 7/16 - 14 x 3/4	1
	HSSH-38-16-038	Socket Head Set Screw 3/8 - 16 x 3/8	1
	14-131	Woodruff Key	1
14*	13-666	Steel Coupler Insert #4	1
15*	13-667	Steel Coupler Half #4 1" Bore	1
	HSSH-716-14-075	Socket Head Set Screw 7/16 - 14 x 3/4	1
	HSSH-38-16-038	Socket Head Set Screw 3/8 - 16 x 3/8	1
	HKSQ-14-100	Machine Key 1/4 x 1/4 x 1	1
16	HB-716-14-125	Bolt 7/16 - 14 x 1 1/4	4
	HWL-716	Lockwasher 7/16	4
17	60-212	Adapter Pump Mount	1
	60-212-01	Cap	1
18	HB-516-18-225	Bolt 5/16 - 18 x 2 1/4	4
	HNCL-516-18	Center Lock Nut 5/16 - 18	4
19	13-710	Rake Lift Assembly	1
20	21-462	Ball Joint 5/16 - 18	2
21	HN-516-18	Nut 5/16 - 18	4
22	13-701	Linkage Rod	1
	HWL-516	Lockwasher 5/16	2
23	13-700	Speed Boss Mount Base	1
24	13-699	Speed Boss Limit Arm	1
	HB-516-18-100	Bolt 5/16 - 18 x 1	1
	HW-516	Washer 5/16	1
	HNTL-516-18	Lock Nut 5/16 - 18	1
25	HB-516-18-100	Bolt 5/16 - 18 x 1	1
	HNTL-516-18	Lock Nut 5/16 - 18	1
26	34-038	Centering Arm	2
27	HP-18-100	Cotter Pin 1/8 x 1	1
28	HMB-12-14	Machine Bushing 14GA x 1/2	3
*	13-664	Coupler Kit	1

REAR AXLE DRAWING

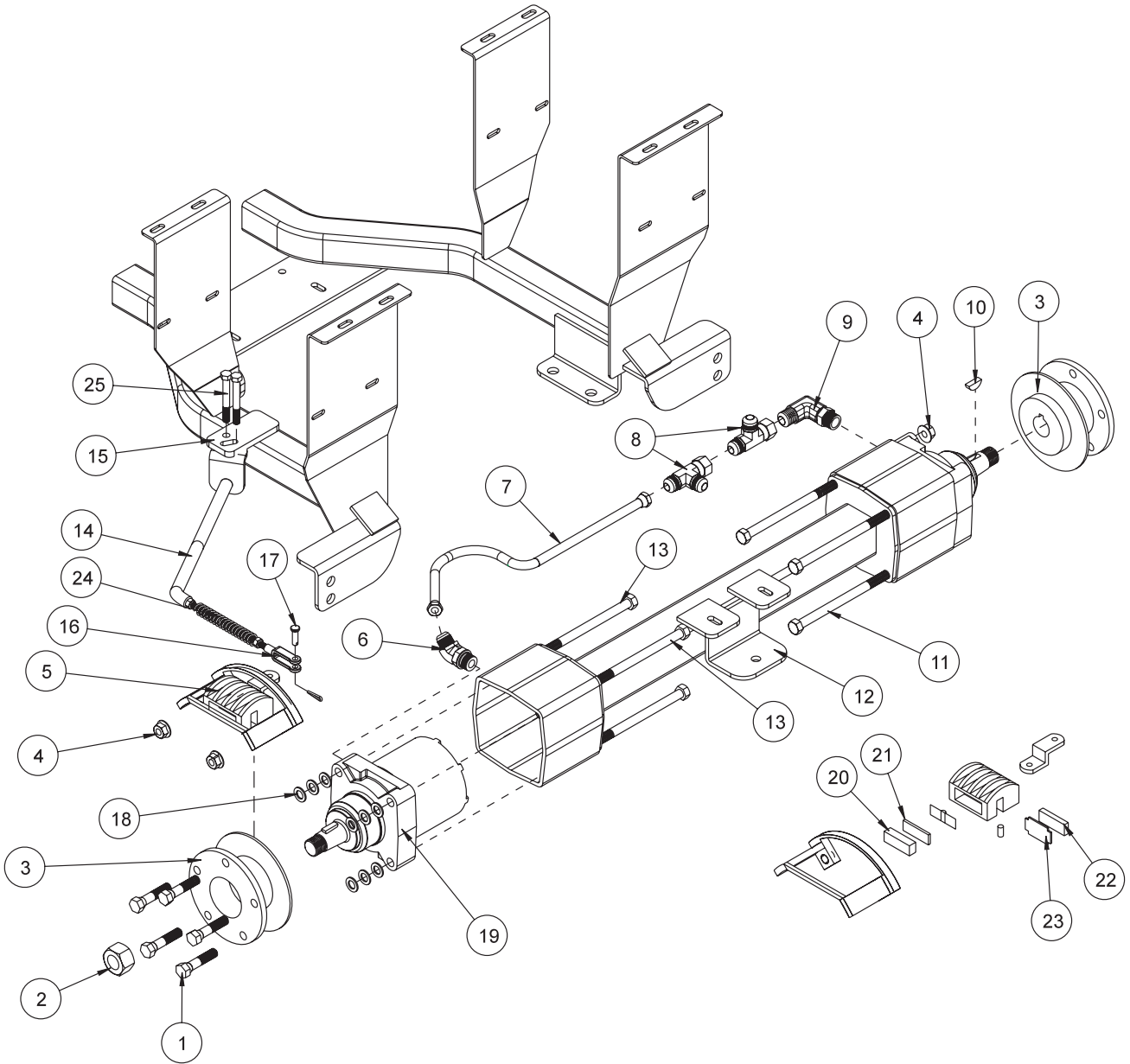

Parts

REAR AXLE PARTSLIST

REF#	PART#	DESCRIPTION	QUANTITY
1	60-268	Lug Bolt $\frac{1}{2}$ - 20 x $1\frac{5}{16}$	10
2	14-265	Nut 1 - 20 (comes with 13-615)	2
3	34-100	Hub and Disc	2
4	HNTL-12-13	Lock Nut $\frac{1}{2}$ - 13	8
5	34-101	Complete Brake	1
6	18-265	45° Elbow	2
7	13-612	Hydraulic Tube Assembly	2
8	34-058	Swivel Tee	4
9	34-122	Elbow	2
10	HWK-516-100	Woodruff Key $\frac{5}{16}$ x 1 (comes with 13-615)	2
11	HB-12-13-700	Bolt $\frac{1}{2}$ - 13 x 7	6
12	13-705	Axle Assembly	1
13	HB-12-13-750	Bolt $\frac{1}{2}$ - 13 x $7\frac{1}{2}$	2
14	14-403	Brake Cable with Nuts	1
	11-100	Linkage Yoke	1
	HN-516-24	Nut $\frac{5}{16}$ - 24	1
15	13-655	Cable Bracket	1
16	11-100	Linkage Yoke	1
	HN-516-24	Nut $\frac{5}{16}$ - 24	1
17	HCP-516-100	Clevis Pin $\frac{5}{16}$ x 1	1
	HP-18-100	Cotter Pin $\frac{1}{8}$ x 1	1
18	HMB-12-14	Machine Bushing $\frac{1}{2}$ x 14GA	6
19	13-615	Wheel Motor	2
20*		Cam Side Pad	1
21*		Cam Side Pad Support	1
22*		Carrier Side Pad	1
23*		Carrier Side Pad Support	1
24	19-205	Compression Spring	1
	HN-516-24	Nut $\frac{5}{16}$ - 24	1
25	HB-38-16-300	Bolt $\frac{3}{8}$ - 16 x 3	2
	HW-38	Washer $\frac{3}{8}$	2
	HNTL-38-16	Lock Nut $\frac{3}{8}$ - 16	2
*	34-101-01	Pad Kit with 2 Pads	1
	34-101-02	Pad Kit with 2 Pads and Steel Backing Hydraulic Oil Filter	

HYDRAULIC OIL FILTER DRAWING

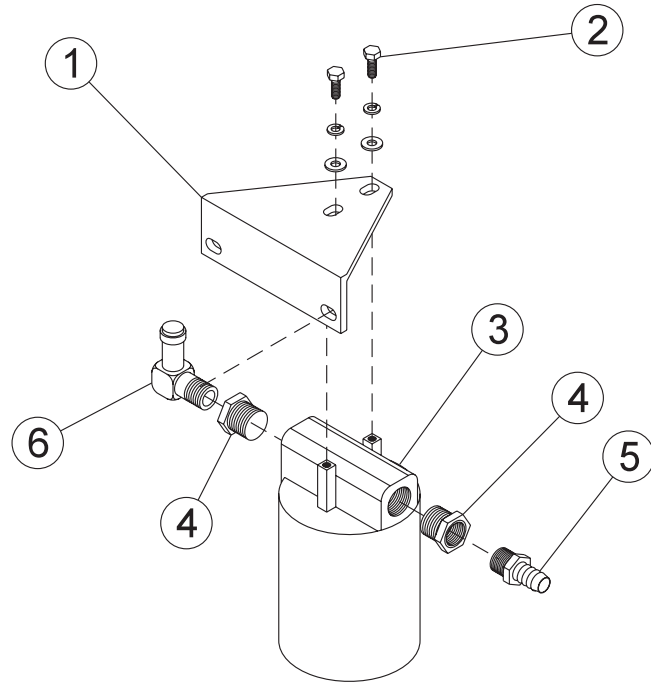

HYDRAULIC OIL TANK DRAWING

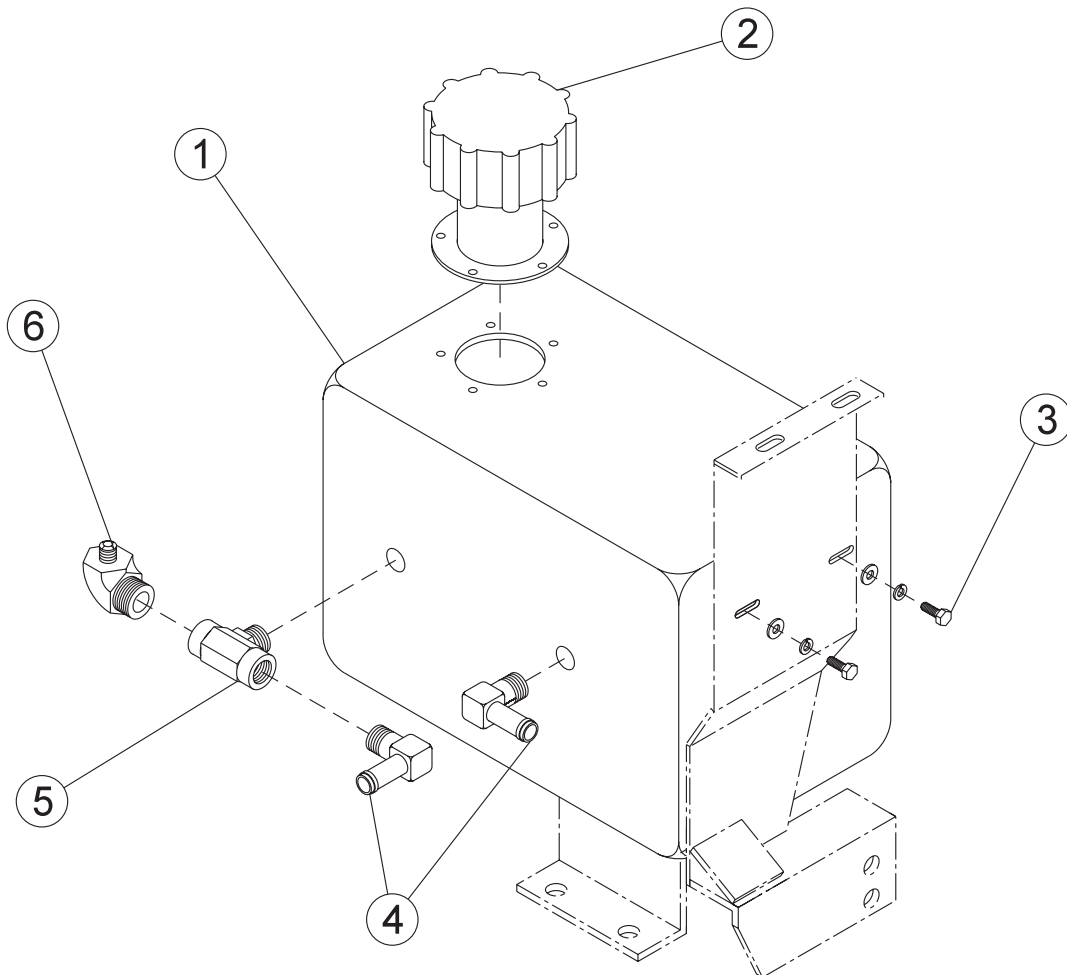

Parts

HYDRAULIC OIL FILTER PARTS LIST

REF#	PART#	DESCRIPTION	QUANTITY
1	13-217	Oil Filter Bracket	1
2	HB-14-20-075	Bolt $\frac{1}{4}$ - 20 x $\frac{3}{4}$	2
	HWL-14	Lock washer $\frac{1}{4}$	2
	HW-10	Washer #10	2
3	23-006	Hydraulic Oil Filter	1
	23-031	Hydraulic Oil Filter Element	1
4	18-008	Reducer Bushing	2
5	23-139	Barb Fitting	1
6	23-142	Elbow	1

HYDRAULIC OIL TANK PARTS LIST

REF#	PART#	DESCRIPTION	QUANTITY
1	13-584	Oil Tank	1
	18-118	Pipe Plug $\frac{1}{8}$	1
2	13-586	Filler Breather	1
	HSM-8-32-050	Machine Screw #8 - 32 x $\frac{1}{2}$	6
	HWL-8	Lockwasher #8	6
3	HB-14-20-075	Bolt $\frac{1}{4}$ - 20 x $\frac{3}{4}$	4
	HWL-14	Lockwasher $\frac{1}{4}$	4
	HW-14	Washer $\frac{1}{4}$	4
4	23-142	Connector	2
5	17-018	Male Branch Tee	1
6	17-019	Male Elbow	1

REAR RAKE LIFT DRAWING

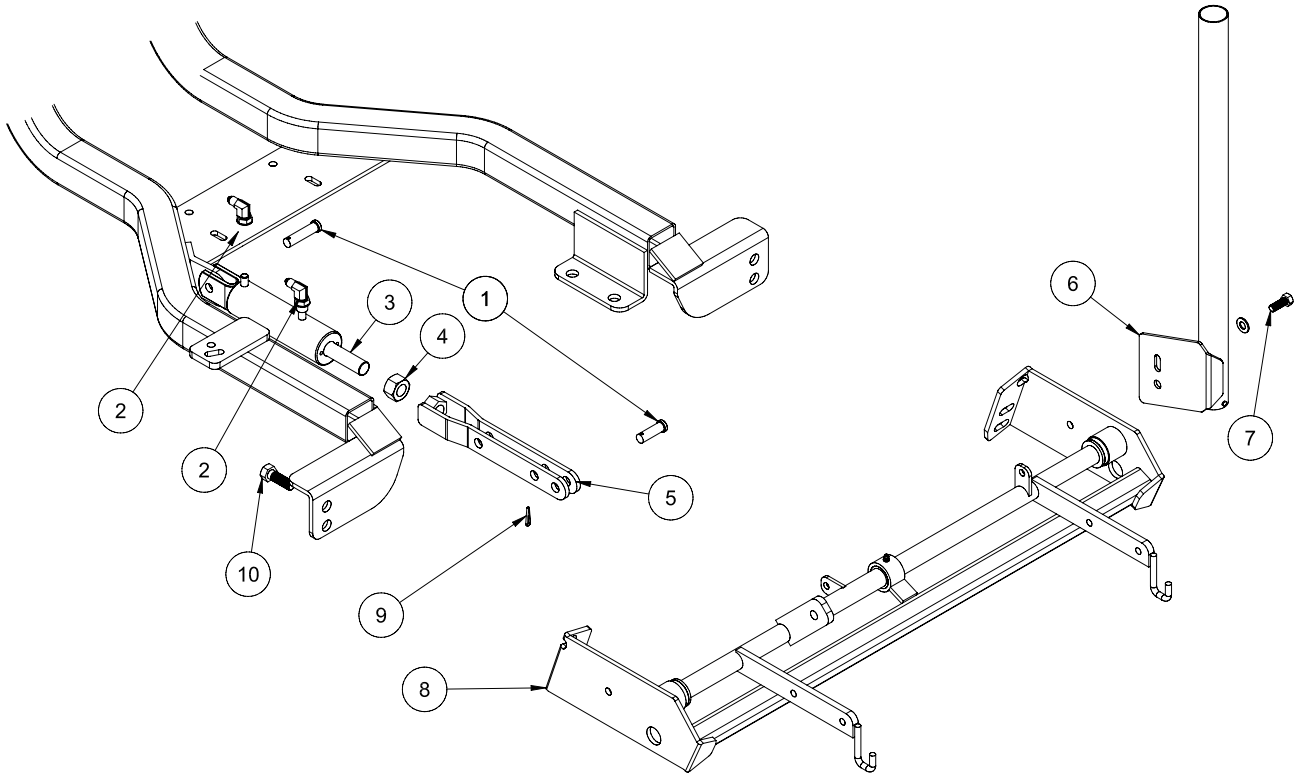

Parts

REAR RAKE LIFT PARTS LIST

REF#	PART#	DESCRIPTION	QUANTITY
1	HCP-12-150	Clevis Pin $\frac{1}{2}$ x $1\frac{1}{2}$	2
2	18-208	Elbow	2
3	13-357	Cylinder	1
	14-253	Seal Kit	1
4	HNJ-34-16	Jam Nut $\frac{3}{4}$ - 16	1
5	13-366	Cylinder Extension	1
6	13-194	Rake Holder	1
7	HB-38-16-100	Bolt $\frac{3}{8}$ - 16 x 1	1
	HW-38	Washer $\frac{3}{8}$	1
	HNTL-38-16	Lock Nut $\frac{3}{8}$ - 16	1
8	13-710	Rake Lift Assembly	1
	HG-14-28-180	Grease Fitting $\frac{1}{4}$ - 28 x 180°	1
9	HP-18-150	Cotter Pin $\frac{1}{8}$ x $1\frac{1}{2}$	2
10	HB-12-13-150	Bolt $\frac{1}{2}$ - 13 x $1\frac{1}{2}$	4
	HW-12	Washer $\frac{1}{2}$	4
	HNTL-12-13	Lock Nut $\frac{1}{2}$ - 13	4

ON-OFF VALVE DRAWING (3WD ONLY)

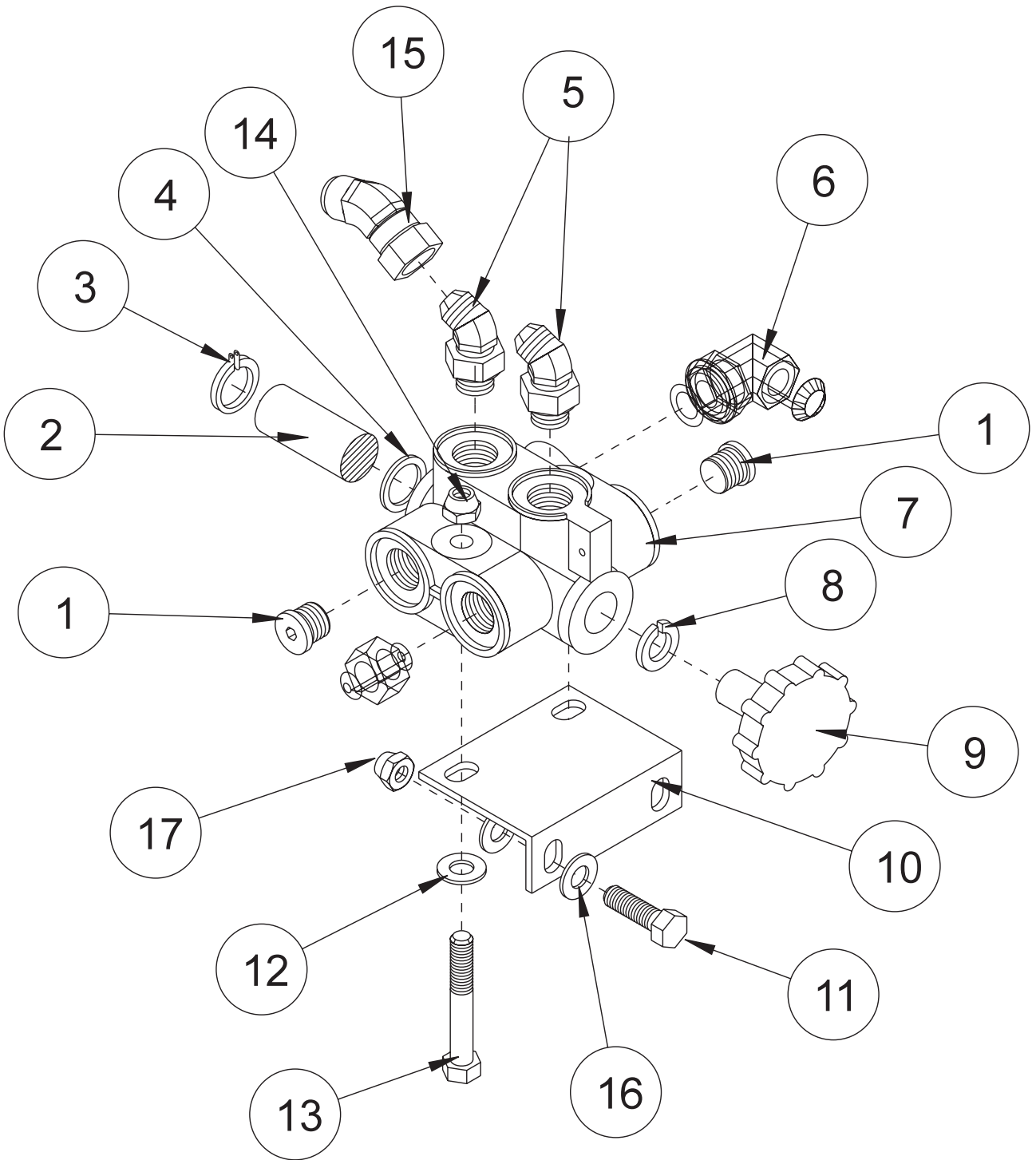

Parts

ON-OFF VALVE PARTS LIST (3WD ONLY)

REF#	PART#	DESCRIPTION	QUANTITY
1	18-228	Hollow Hex Plug	2
2*	14-243	Spool	1
3*	14-242	Snap Ring	2
4*	14-244	Quad Seal	2
5	18-174	Elbow 1/2 - 45°	2
6	18-266	Elbow 45°	2
7*		Valve Body	1
8*	14-245	Lockwasher	1
9*	14-246	Knob	1
	34-224	Decal, 2W/3W Drive	1
10	13-427	Valve Bracket	1
11	HST-516-18-100	Bolt 5/16 - 18 x 1	2
12	HW-38	Washer 3/8	2
13	HB-38-16-250	Bolt 3/8 - 16 x 2 1/2	2
14	HNTL-38-16	Lock Nut 3/8 - 16	2
15	34-044	45° Elbow	1
16	HW-51	Washer 5/16	2
17	HNTL-516-18	Lock Nut 5/16 - 18	2
*	13-409	On-Off Valve	

13-729 2-BANK HYDRAULIC VALVE DRAWING

Parts

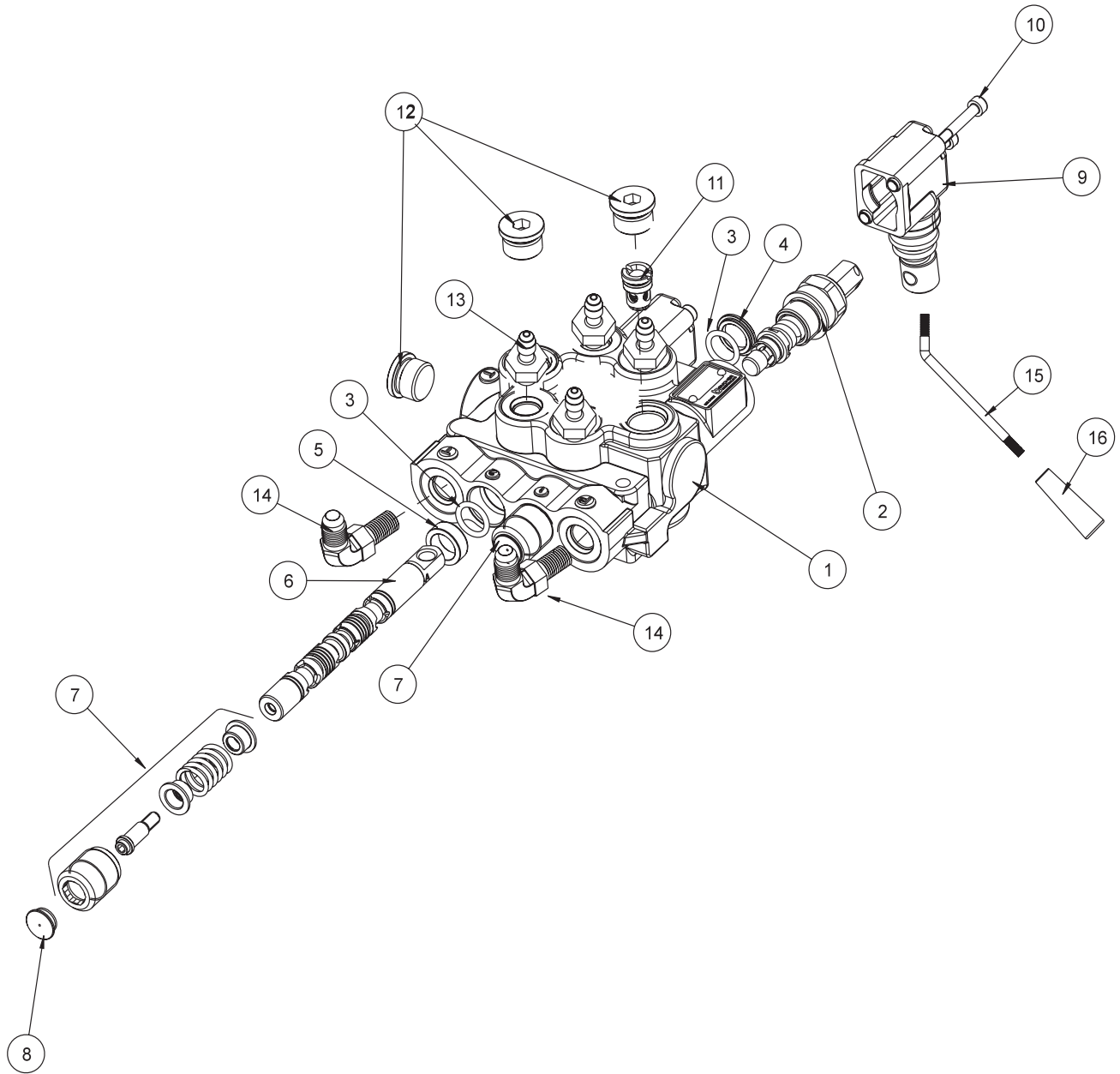

13-729 2-BANK HYDRAULIC VALVE PARTSLIST

REF#	PART#	DESCRIPTION	QUANTITY
1*	78-415-01	Body (complete with spacer and check valve)	1
2*	78-415-02	Spool HDM10	1
3*	78-415-03	O-Ring Seal	6
4*	78-415-04	Flanged Washer HDM10	3
5*	78-415-05	Spacer	3
6*	78-415-06	A Type Spool HDS11	3
7*	78-415-11	Positioner	2
8*	78-415-08	Plug	3
9*	78-415-09	Lever Group HDS11	3
10*	78-415-10	Metric Socket Screw M5 x .8 x 45	6
11*	78-415-12	Check Valve Assembly HDM12	1
12*	78-415-13	$\frac{3}{4}$ - 16 SAE 8 Screw Plug	3
13	18-166	Adapter $\frac{1}{4}$ - $\frac{3}{8}$ SAE	4
14	18-168	Elbow $\frac{3}{8}$ Straight Thread	2
15	78-418	Bent Handle	2
16		Tapered Knob	3
* 13-729		2 – Bank Hydraulic Valve (includes all * items)	

NOTE:

Two wheel drive will only have one handle and two ports will be plugged with 23-126 O-ring Plugs.

13-110 VARIABLE PUMP DRAWING

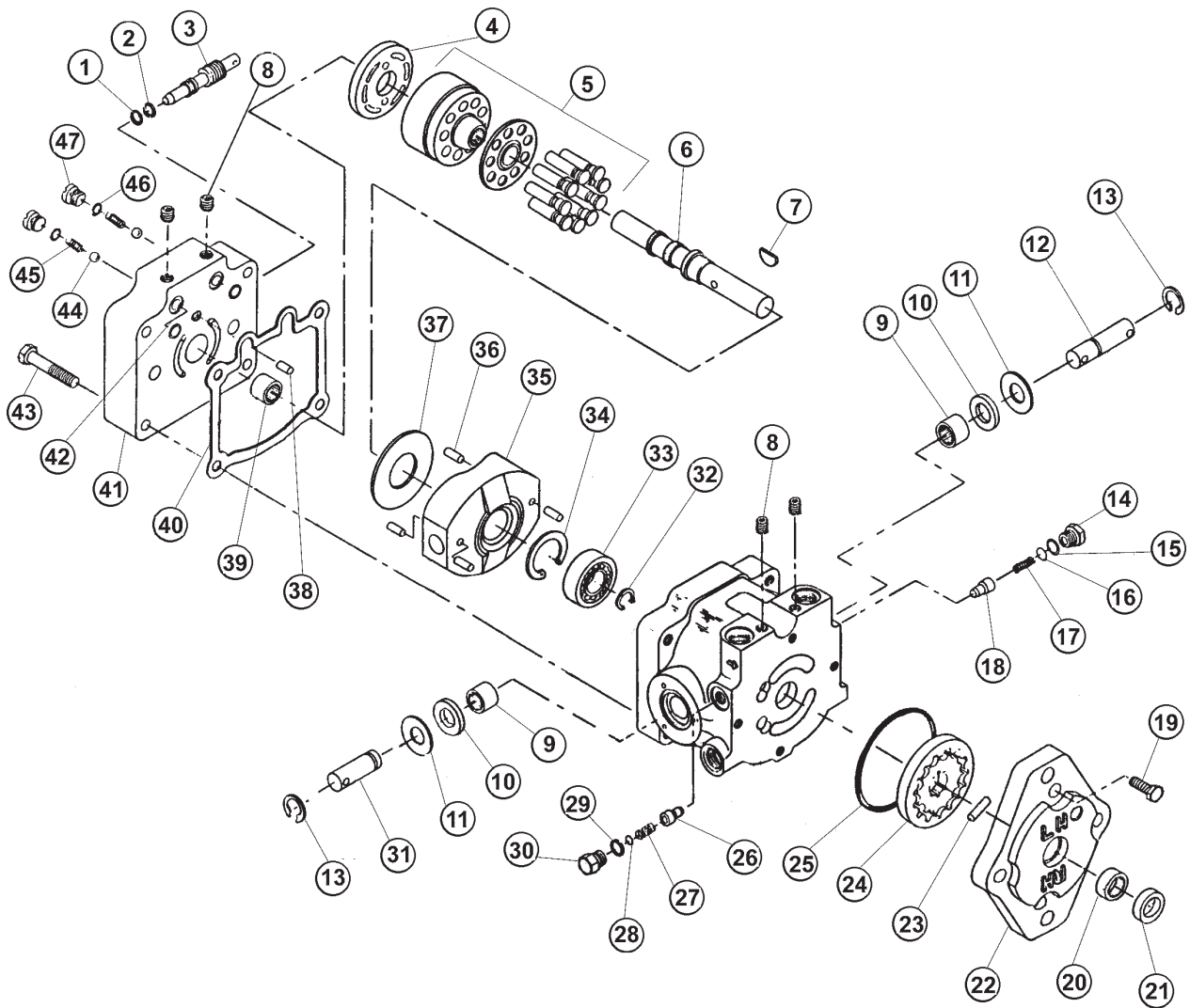

Parts

13-110 VARIABLE PUMP PARTS LIST

REF#	PART#	DESCRIPTION	QUANTITY
1	14-222	O-Ring	1
2	14-130	Ring	1
3	13-110-01	By-Pass Valve	1
4	14-115	Valve Plate	1
5†		Cylinder Block	1
6	14-084	Pump Shaft	1
7	14-131	Woodruff Key	1
8	13-110-05	Pipe Plug	4
9	14-069	Needle Bearing	2
10*	14-014	Lip Seal	2
11	14-113	Washer	2
12	14-220	Truncated Shaft (long 2 holes)	1
13	14-105	Retaining Ring	2
14‡	13-110-10	Plug	1
15*‡		O-Ring	1
16‡	14-219	Shim Pack Kit	1
17‡	14-234	Release Valve Spring	1
18‡	14-235	Release Valve Cone	1
19§	13-110-14	Hex Head Screw	4
20§	14-129	Needle Bearing	1
21*§	14-054	Lip Seal	1
22§	13-110-13	Charge Pump Housing	1
23§	14-135	Straight Pin	1
24§	14-136	Gerotor Assembly	1
25*§		O-Ring	1
26£	14-235	Release Valve Cone	1
27£	14-234	Check Release Valve Spring	1
28£	14-219	Shim Pack Kit	1
29*£		O-Ring	1
30£	13-110-10	Plug	1
31	14-212	Truncated Shaft (short 1 hole)	1
32	14-133	Retaining Ring	1
33	14-128	Ball Bearing	1
34	14-132	Retaining Ring	1
35	14-221	Variable Swash Plate	1
36	14-216	Spring Pin	3
37	14-114	Thrust Plate	1
38	14-215	Pin	1
39	14-217	Roller Bearing	1
40*	14-107	Gasket	1
41†		Pump End Cap	1
42*		O-Ring	2
43	13-110-04	Hex Head Screw	4
44▣	13-110-09	Ball	2
45▣	13-110-08	Check Valve Spring	2
46*▣		O-Ring	2
47▣	13-110-07	Check Valve Plug	2

*	14-098	Seal Kit
†	Parts are not available. Replace with new unit.	
§	13-110-15	Charge Pump
▣	13-110-16	Check Valve Kit
£	14-214	Relief Valve Kit
‡	13-110-17	Relief Valve Kit

13-032 FRONT WHEEL MOTOR (4.9 C.I.) DRAWING

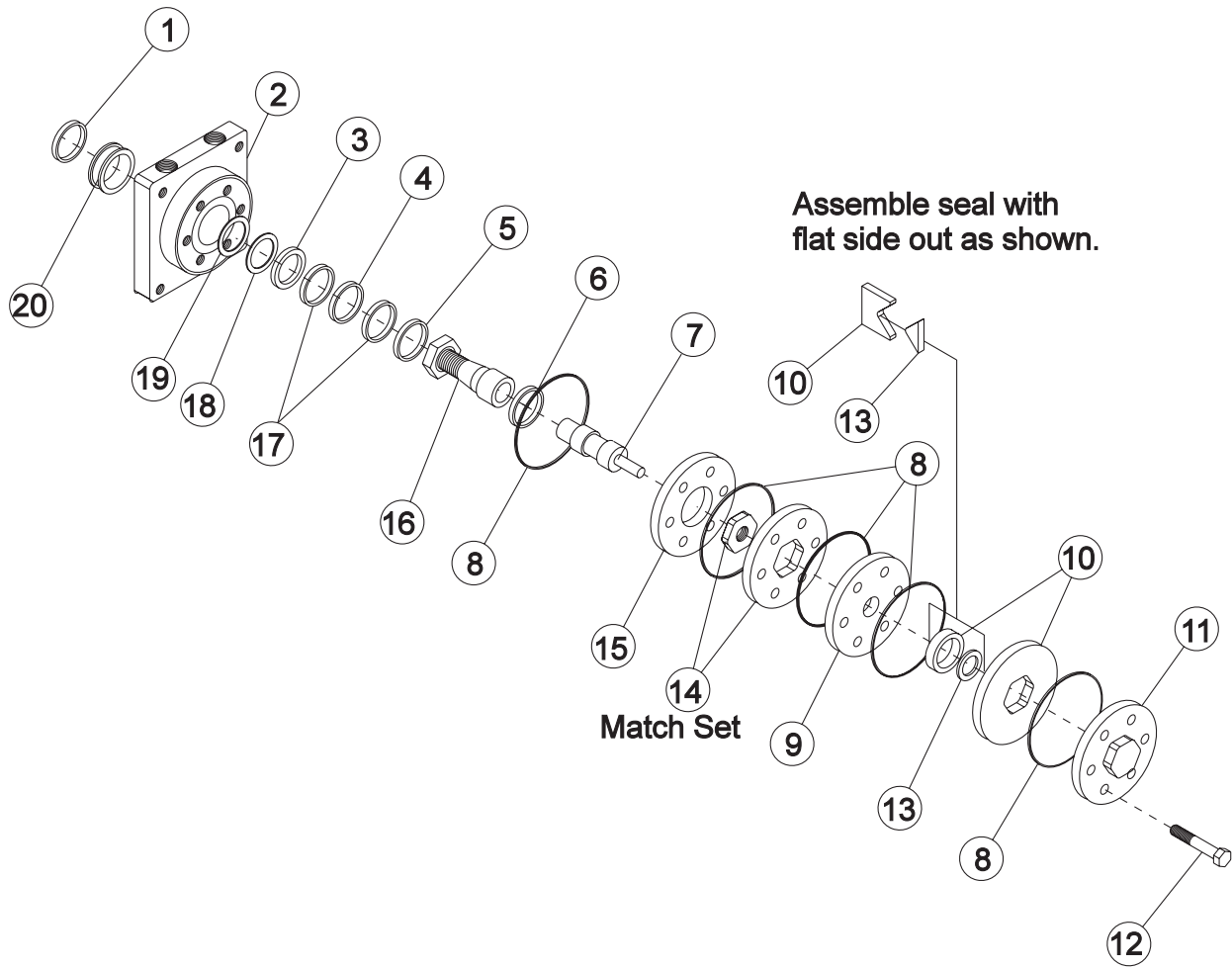

13-032 FRONT WHEEL MOTOR (4.9 C.I.) PARTSLIST

REF#	PART#	DESCRIPTION	QUANTITY
1*		Water & Dirt Seal	1
2		Service Housing Assembly	1
3*		Inner Seal	1
4	13-032-27	Thrust Bearing	1
5	13-032-28	Inner Bearing	1
6	13-032-29	Thrust Bearing	1
7	13-032-30	Drive Link	1
8*		Ring Seal	5
9	13-032-31	Manifold	1
10	13-032-32	Commutator Assembly (matched set)	1
11	13-032-33	End Cover	1
12	14-134	Bolt	7
13*		Commutator Seal (matches with #10)	1
14	13-032-34	Rotor Set (matched set)	1
15	13-032-35	Plate Wear	1
16	13-032-36	Coupling Shaft	1
	HWK-516-100	Woodruff Key ⁵ / ₁₆ x 1	1
	14-265	Nut 1 - 20	1
17	13-032-37	Thrust Washer	2
18*		Backup Washer	1
19*		Backup Washer	1
20	13-032-38	Outer Bearing	1
*	14-080	Seal Kit	1

13-615 REAR WHEEL MOTOR (7.5 C.I.) DRAWING

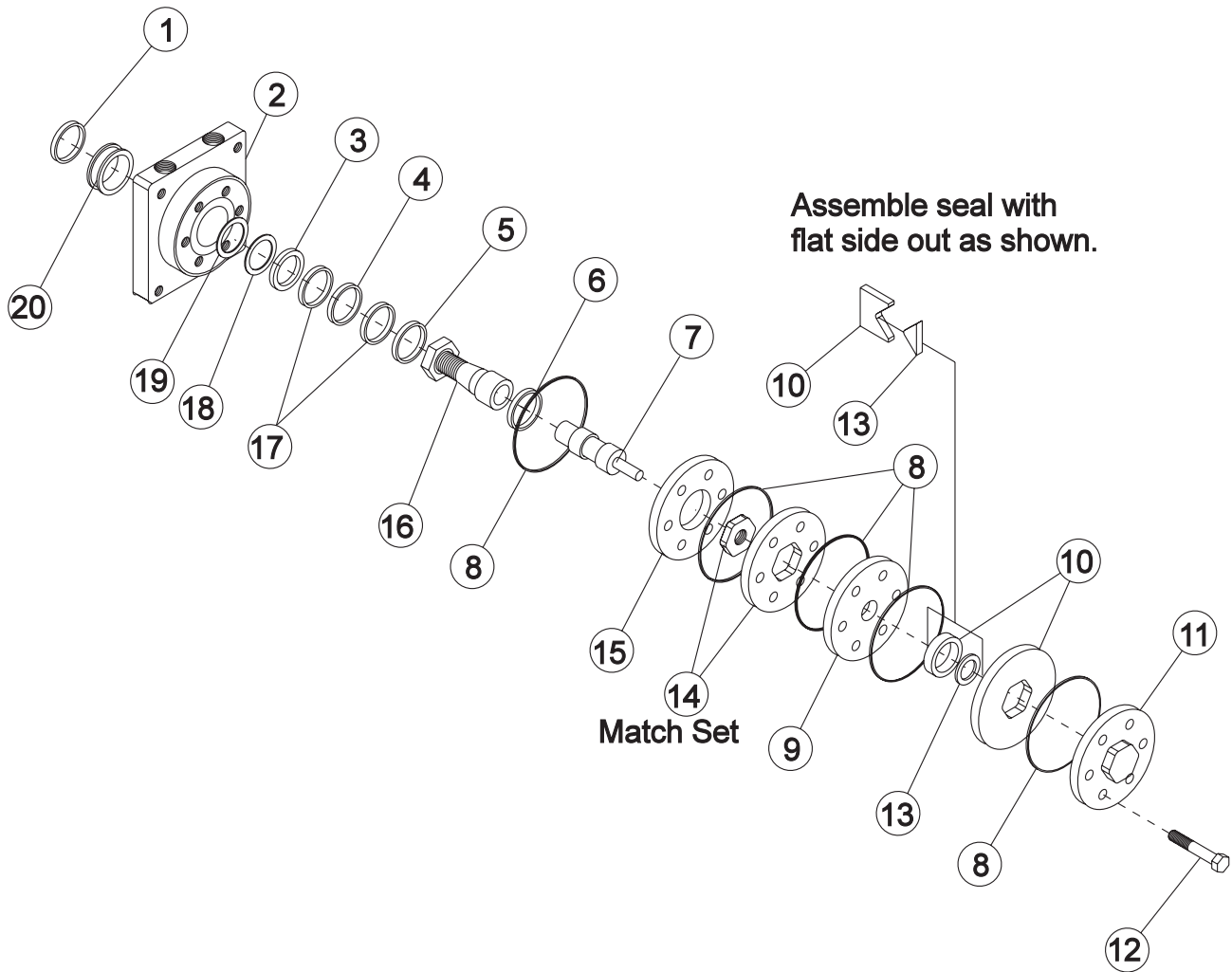

13-615 REAR WHEEL MOTOR (7.5 C.I.) PARTSLIST

REF#	PART#	DESCRIPTION	QUANTITY
1*		Water & Dirt Seal	1
2	13-615-05	Service Housing Assembly (Includes Ref 4, 5, 17(2 req'd) and 20)	1
3*		Inner Seal	1
4	13-032-27	Thrust Bearing	1
5	13-032-28	Inner Bearing	1
6	13-032-29	Thrust Bearing	1
7	13-615-03	Drive Link	1
8*		Ring Seal	5
9	13-032-31	Manifold	1
10	13-032-32	Commutator Assembly (matched set)	1
11	13-032-33	End Cover	1
12	13-615-01	Bolt	7
13*		Commutator Seal (matches with #10)	1
14	13-615-02	Rotor Set (matched set)	1
15	13-032-35	Plate Wear	1
16	13-615-04	Coupling Shaft	1
	HWK-516-100	Woodruff Key ⁵ / ₁₆ X 1	1
	14-265	Nut 1 - 20	1
17	13-032-37	Thrust Washer	2
18*		Backup Washer	1
19*		Backup Washer	1
20	13-032-38	Outer Bearing	1
*	14-080	Seal Kit	1

13-505 LIFT ASSEMBLY DRAWING

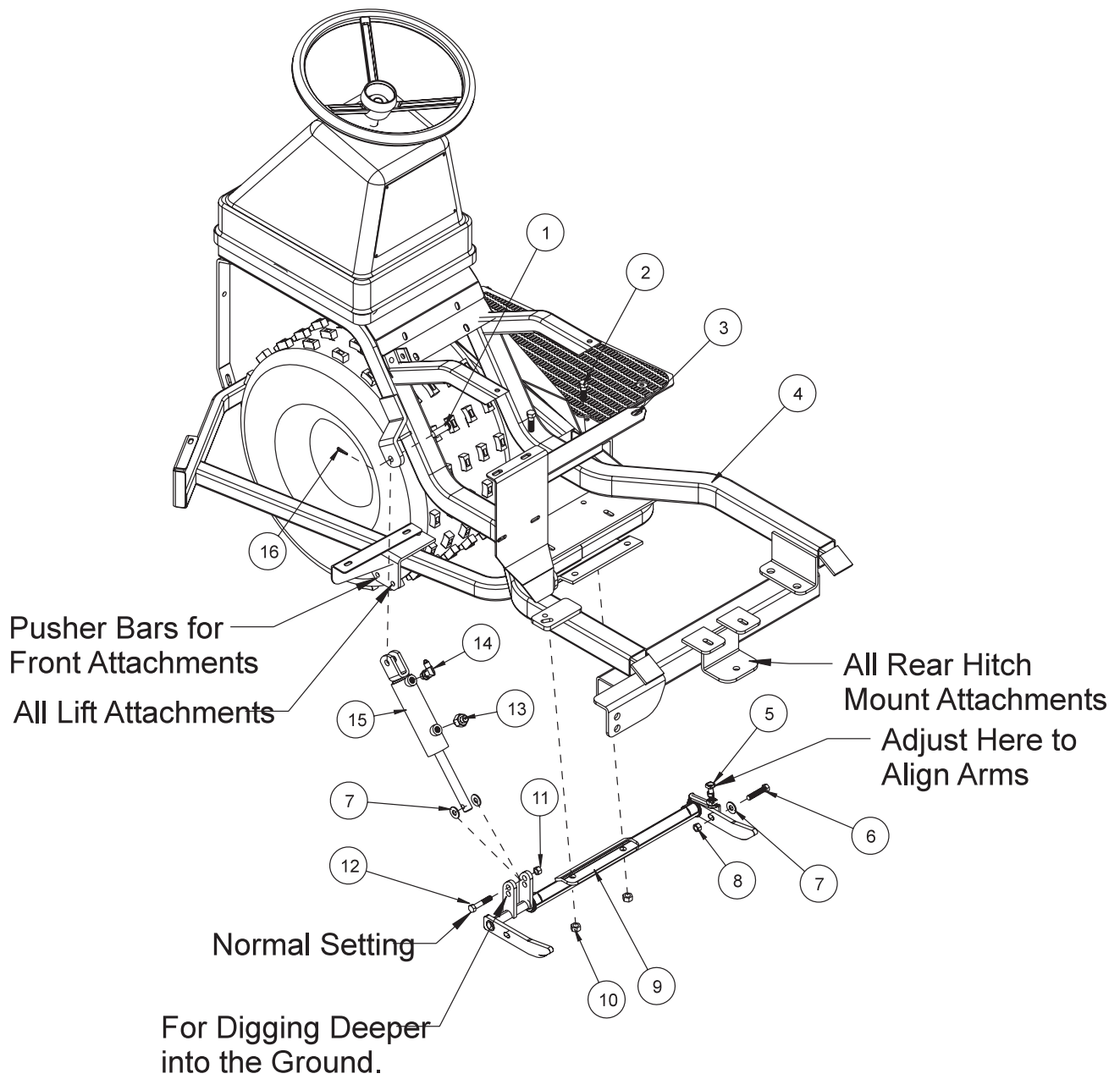

Accessories

13-505 LIFT ASSEMBLY PARTS LIST

REF#	PART#	DESCRIPTION	QUANTITY
1	HCP-12-150	Clevis Pin 1/2 x 1 1/2	1
2	HB-716-14-150	Bolt 7/16 -14 x 1 1/2	2
3	13-004	Cooler Bracket	1
4		Main Frame (Part of Trap Rake)	
5	HSSQ-38-16-200	Square Head Set Screw 3/8 - 16 x 2	1
	HN-38-16	Nut 3/8 - 16	1
6	HB-38-16-125	Bolt 3/8 -16 x 1 1/4	1
7	HW-38	Washer 3/8	3
8	HNTL-38-16	Lock Nut 3/8 -16	1
9	13-146	Attachment Lift	1
10	HNTL-716-14	Lock Nut 7/16 -14	2
11	HNTL-38-16	Lock Nut 3/8	1
12	HB-38-16-200	Bolt 3/8 -16 x 2	1
13	18-166	Adapter	3
14	18-292	Elbow with Orifice	1
15	13-292	Hydraulic Cylinder	1
16	HP-18-150	Cotter Pin 1/8 x 1 1/2	1
	18-164	Hydraulic Hose	2
	14-253	Seal Kit for 13-292	

INSTALLATION INSTRUCTIONS

13-505 Lift Assembly comes standard on 13-550 Super Rake optional on 13-551 Super 2.

1. Raise and block machine so you can get under it safely.
2. Replace bolts (Ref 2) located toward rear of machine with two new 7/16 - 14 x 1 1/2 bolts. Place attachment lift (Ref 9) under frame with cylinder tabs on left side of machine and the arms pointing to rear. Use two 7/16 - 14 lock nuts to hold in place.
3. Lower machine to ground.
4. Connect cylinder (Ref 15) to frame (Ref 4) using clevis pin (Ref 1) and cotter pin (Ref 16) with cylinder ports pointing up.
5. Bolt rod end of cylinder in top hole of attachment lift (Ref 9) using bolt (Ref 12), two washers (Ref 7) (one on each side of cylinder rod) and locknut (Ref 11). Bolt head should be to the outside.
6. Before making the attachment adjustment, be sure tire pressure in all tires is the same. On a level surface, lower attachment to ground until one side touches. On the right side of the attachment lift there is an adjustment bolt and screw (Ref 5 and 6) to level the arms.
7. If adjustable side is high, adjust square head set screw (Ref 5) to lower attachment so that it is level with the ground. If adjustable side is low, adjust the square head set screw to raise attachment level to the ground. Tighten lock nut.
8. Put bolts (Ref 6) with one 3/8 washer through arm and bracket. The bolt head should be to the outside of machine, with lock nut on inside.
9. Put elbow (Ref 14) with orifice into port on clevis end of cylinder (pointing to rod end) and tighten. Put one adapter (Ref 13) in other port and tighten.
10. Remove two plugs from valve and replace with two adapters. Tighten both adapters.
11. To connect hoses, first connect tube end of hose to adapter on rod end of cylinder. Leave it loose. Route hose to bottom port of valve. Tighten both ends of hose. Then connect other hose (hose end) to elbow in cylinder and tube end to top port of valve. Tighten both ends of the hose.
12. Assemble valve handle to valve.
13. Sit on seat and start machine. Work the valve so lift will raise and lower. Do this until air works out and cylinder operates smoothly. At same time check for hydraulic leaks. Shut engine off.
14. Check hydraulic oil tank level. The level should be about 2" to 2 1/2" from top of the tank when fluid is cold. Use SAE 10W-40 API Service SJ or higher motor oil.

13-680 HYDRAULIC PLOW WITH LIFT DRAWING (Dealer Installed)

13-679 HYDRAULIC PLOW WITH LIFT DRAWING (Factory Installed)

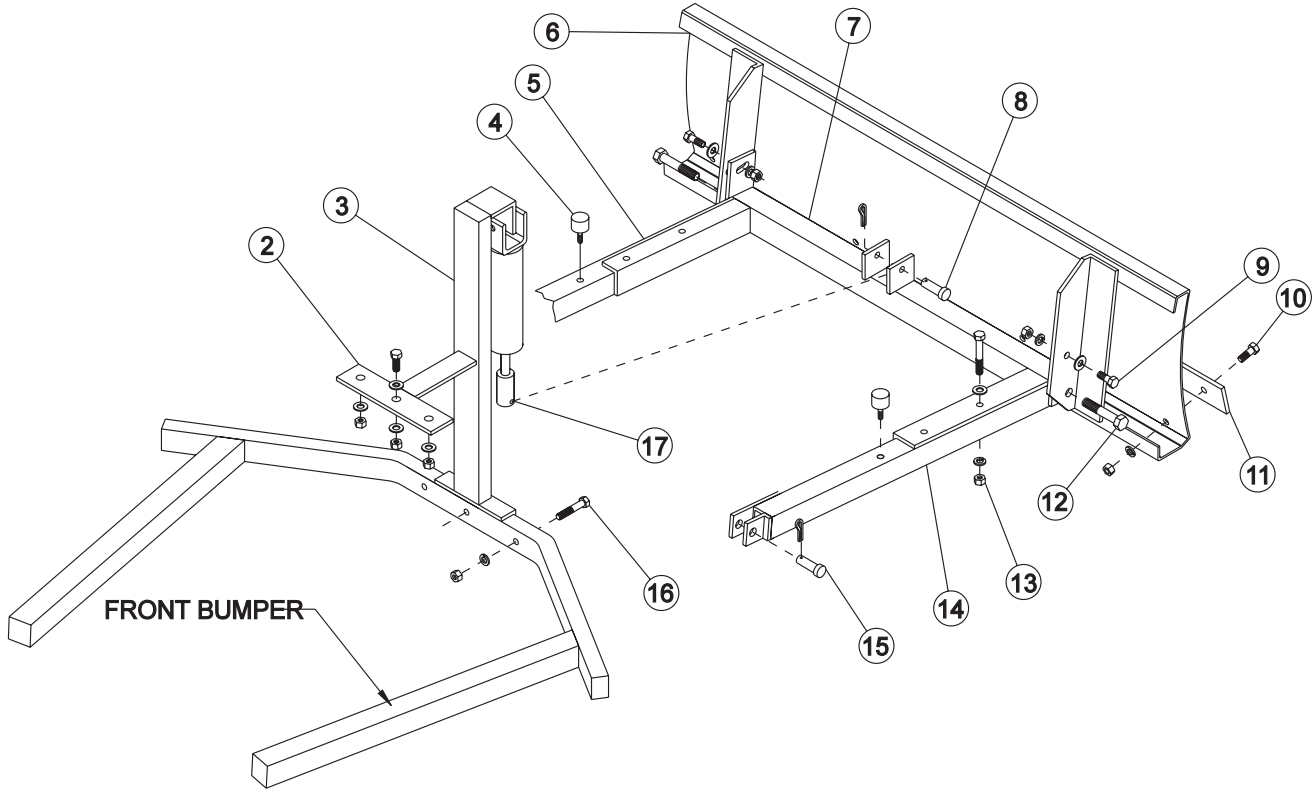

HYDRAULIC VALVE PLUMBING

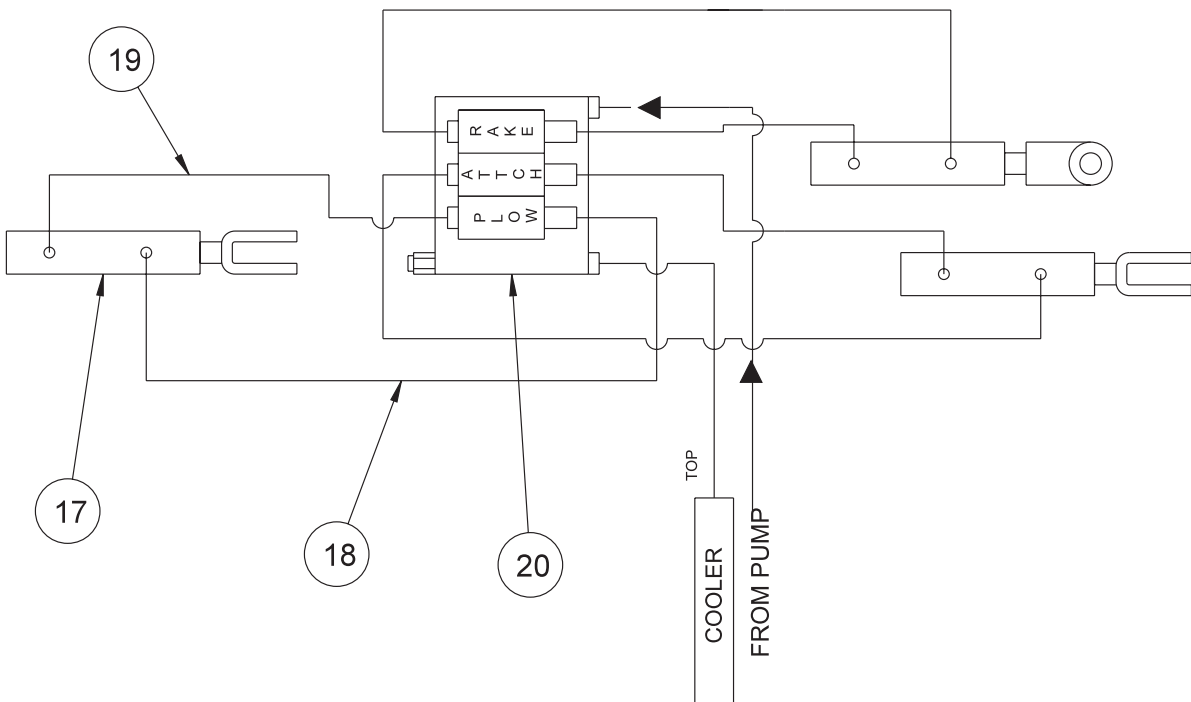

Accessories

13-680 HYDRAULIC PLOW WITH LIFT PARTS LIST (Dealer Installed)

13-679 HYDRAULIC PLOW WITH LIFT PART LIST (Factory Installed)

REF#	PART#	DESCRIPTION	QUANTITY
2	13-325	Brace	1
	HB-38-16-100	Bolt $\frac{3}{8}$ - 16 x 1	1
	HW-38	Washer $\frac{3}{8}$	4
	HNCL-38-16	Center Lock Nut $\frac{3}{8}$ -16	3
3	13-407	Cylinder Bracket	1
4	15-013	Rubber Bumper	2
	HWL-14	Lockwasher $\frac{1}{4}$	2
5	13-168	Left Pusher Bar	1
6	13-352	Hydraulic Sand Plow	1
7	13-322	Lift Bar	1
8	HCP-12-200	Clevis Pin $\frac{1}{2}$ x 2	1
	HHP-18	Bridge Pin $\frac{1}{8}$	1
9	HB-38-16-125	Bolt $\frac{3}{8}$ -16 x $1\frac{1}{4}$	2
	HW-38	Washer $\frac{3}{8}$	2
	HWL-38	Lockwasher $\frac{3}{8}$	2
	HN-38-16	Nut $\frac{3}{8}$ -16	2
10	HB-38-16-100	Bolt $\frac{3}{8}$ -16 x 1	4
	HWL-38	Lockwasher $\frac{3}{8}$	4
	HN-38-16	Nut $\frac{3}{8}$ -16	4
11	13-167	Wear Blade	1
12	HB-12-13-300	Bolt $\frac{1}{2}$ -13 x 3	2
	HWL-12	Lockwasher $\frac{1}{2}$	2
	HN-12-13	Nut $\frac{1}{2}$ - 13	2
13	HB-38-16-225	Bolt $\frac{3}{8}$ -16 x $2\frac{1}{4}$	4
	HW-38	Washer $\frac{3}{8}$	4
	HNCL-38-16	Center Lock Nut $\frac{3}{8}$ - 16	4
14	13-169	Right Pusher Bar	1
15	HCP-12-150	Clevis Pin $\frac{1}{2}$ x $1\frac{1}{2}$	2
	HHP-18	Bridge Pin $\frac{1}{8}$	2
16	HB-38-16-250	Bolt $\frac{3}{8}$ -16 x $2\frac{1}{2}$ (part of Trap Rake)	2
	HWL-38	Lockwasher $\frac{3}{8}$ (part of Trap Rake)	2
	HN-38-16	Nut $\frac{3}{8}$ -16 (part of Trap Rake)	2
17	13-406	Hydraulic Cylinder	1
	14-267	Seal Kit	1
	23-141	Union Adapter	1
	HNJ-58-18	Jam Nut $\frac{5}{8}$ - 18	1
	23-018	O-ring Elbow	1
	13-324	Ram Extension	1
	HCP-58-175	Clevis Pin $\frac{5}{8}$ x $1\frac{1}{4}$	1
	HHP-18	Bridge Pin $\frac{1}{8}$	1
18	13-687	Hydraulic Hose 55"	1
19	13-686	Hydraulic Hose 64"	1
20	13-730	3 Bank Hydraulic Valve	1

13-680 HYDRAULIC PLOW WITH LIFT DRAWING (Dealer Installed)

13-679 HYDRAULIC PLOW WITH LIFT DRAWING (Factory Installed)

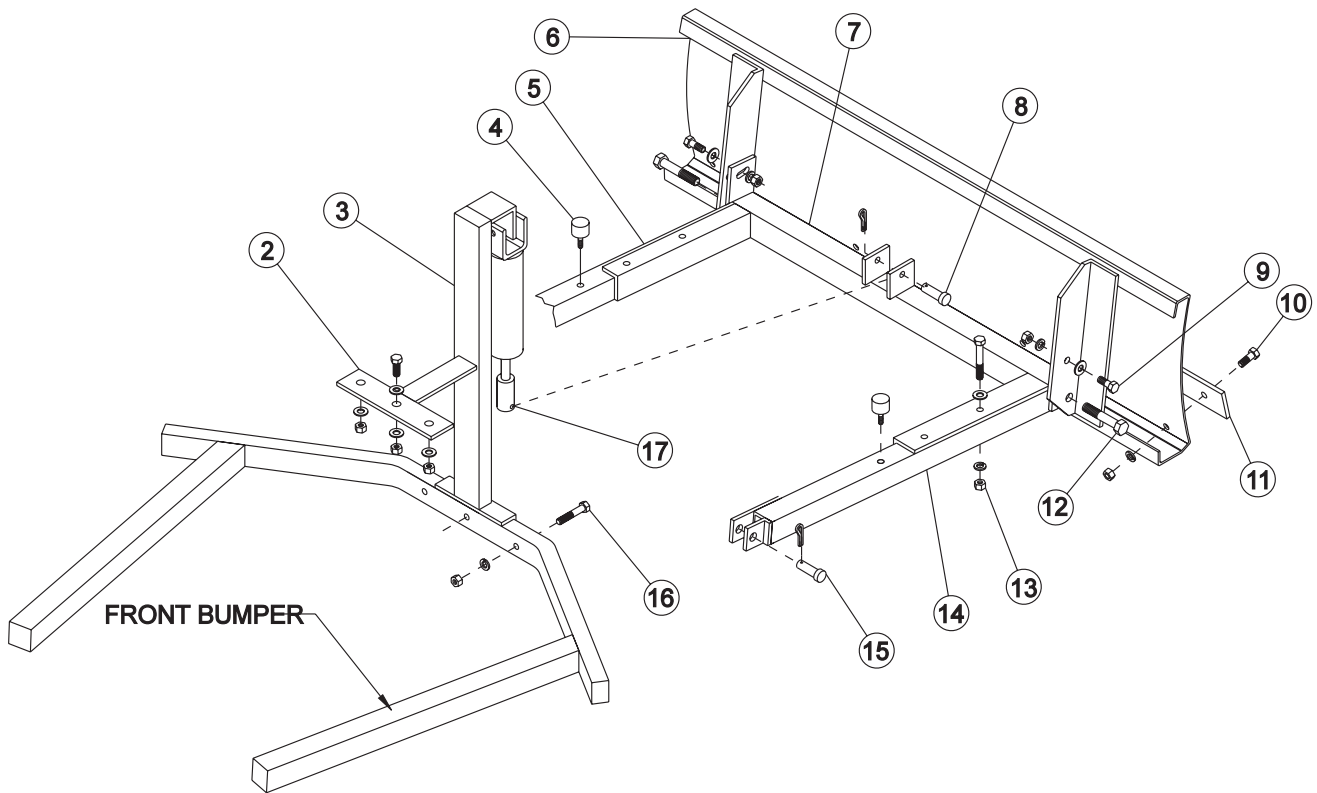

Accessories

INSTALLATION INSTRUCTIONS

1. Loosely bolt brace (Ref 2), to cylinder bracket (Ref 3) with the brace on top. The bolt and washer are on top; the washer and nut are on the bottom.
2. Remove two bolts that go through the bumper and bumper brace. Use these to bolt the cylinder bracket to the bumper.
3. Place the cylinder bracket to the bumper so that the brace will fit over the ends of the bolt (ones holding the top ends of the bumper brace). Fasten it to the bolts with a washer and a center lock nut on each side. Bolt the bottom of the Cylinder Bracket to the bumper with the bolts from above. Tighten all fasteners.
4. Fasten pusher bars (Ref 5 and 14) to the sand plow (Ref 6), as shown. Leave loose.
5. Fasten lift bar (Ref 7) to the pusher bars as shown. Leave loose.
6. Put the Plow in front of the Trap Rake and slide it back so that the Pusher Bars can be connected to the tabs on the frame with clevis pin and bridge pin (Ref 15).
7. Tighten the bolts and nuts holding the left bar to the pusher bars.
8. Set the plow at the desired angle and tighten the bolts and nuts holding it to the pusher bars.
9. Attach the hydraulic cylinder to the cylinder bracket with the $\frac{5}{8} \times 1\frac{3}{4}$ clevis pin and one $\frac{1}{8}$ bridge pin. The ports on the cylinder must point to the left side of the machine.
10. Thread the jam nut and the ram extension onto the cylinder rod end and leave them loose to find the required length.
11. Either extend the rod or raise the plow up and fasten them together with the $\frac{1}{2} \times 2$ clevis pin and $\frac{1}{8}$ bridge pin.
12. Put the handles on the 3-bank valve with the straight one in the middle and the bent ones pointing to the outside.
13. Mark the hoses on the 2-bank valve that is on the machine so that they can be put in the same position on the 3-bank valve.
14. Disconnect the negative (-) ground battery cable from the battery. Place a drain pan under the valve in the machine. Be sure engine is cool before disconnecting the hoses. Remove the 2-bank valve.
15. Remove the fittings from the 2-bank valve and put them into the 3-bank valve (with the inside bank for the sand plow). Put the two adapters (23-011), into the ports for the gas trap rake.
16. Put the 3-bank valve into the machine and reconnect the hoses. The outside bank is the rake lift; middle bank is the attachment lift; the inside bank is for the sand plow.
17. Drill a $\frac{3}{8}$ diameter hole in the left floorboard, 12 inches forward from the rear edge and $3\frac{1}{2}$ inches down from the edge.
18. Put the o-ring elbow into the top port of the cylinder and the union adapter into the bottom port. Both fittings should point down and towards the rear of the machine. Do not tighten fittings at this time.
19. Connect the two hoses to the cylinder using the ridge end first. Connect hose (55" long) (13-687) to the bottom of the cylinder and the bottom of the valve. Connect hose (64" long) (13-686) to the top of the cylinder to the top of the valve. Route the hose along the left side floorboard and up to the valve being careful to leave clearance by moving parts. Tighten all fittings.
20. Secure the two hoses to the inside of the left floorboard using hose strap (60-501). Place the $\frac{5}{16}$ - 18 x $1\frac{1}{2}$ truss machine screw through the hole you drilled with one hose on each side of the screw. Place the hose strap over the screw and hoses, tighten $\frac{5}{16}$ - 18 center locknut. Use one nylon tie about half way to the cylinder and the other about half way to the valve.
21. Reconnect the negative (-) ground battery cable to battery.
22. Make sure that everything is clear of the machine. Start the machine, work the valve so that the plow will both raise and lower. Also, do this with both the attachment lift and the rake lift. Work the lift a number of times until all air works out of the plow circuit and the cylinder works smoothly. At this time look for hydraulic leaks. If there are leaks, turn engine off and repair, start up and check again.
23. Double check all fasteners and fittings, be sure they are tight.
24. Check the hydraulic oil level. The level should be 2" to $2\frac{1}{2}$ " from the top of the tank. If more is needed, use SAE 10W-40 API service SJ or higher motor oil.

13-730 3-BANK HYDRAULIC VALVE DRAWING

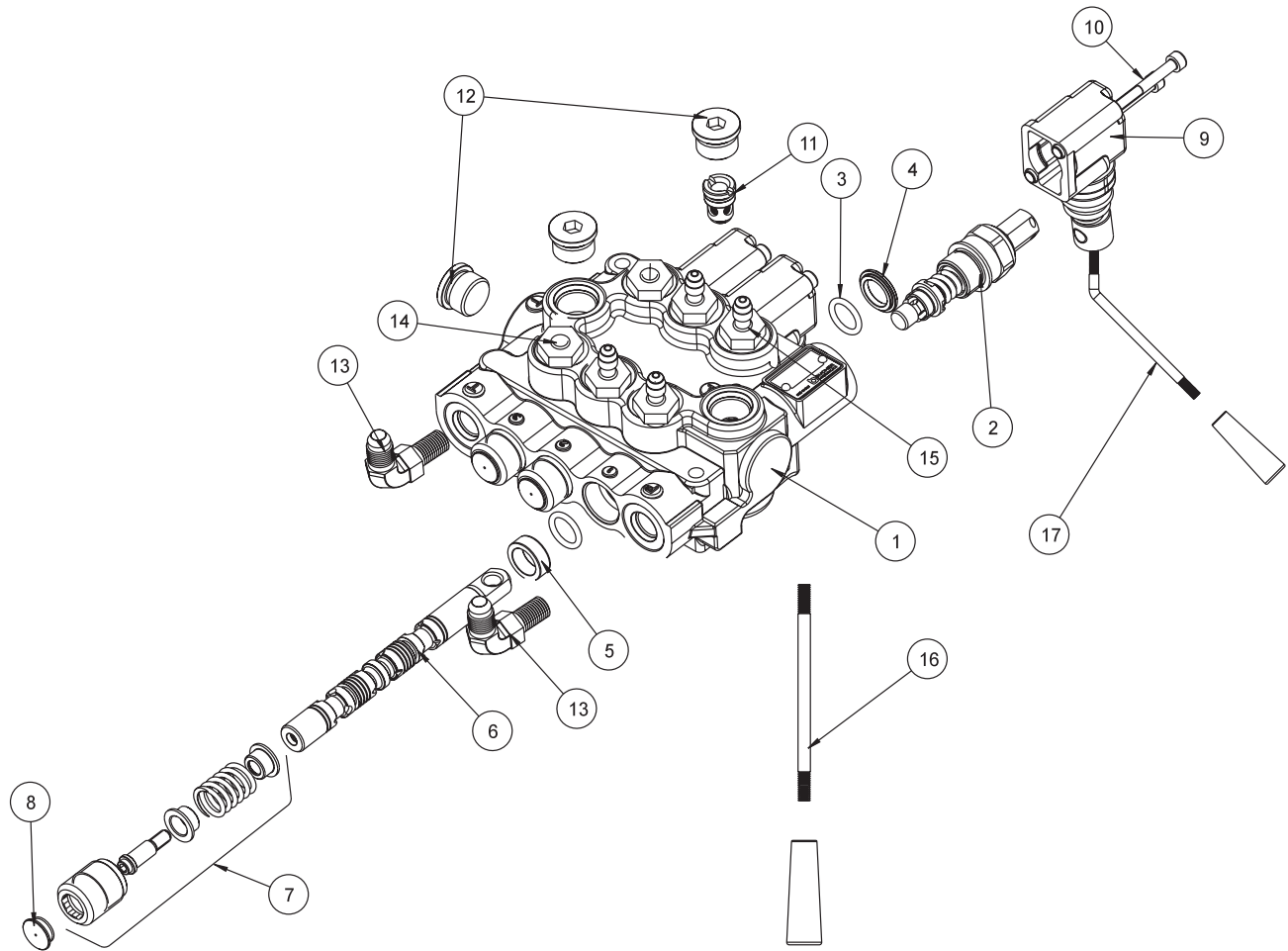

Accessories

13-730 3-BANK HYDRAULIC VALVE PARTSLIST

REF#	PART#	DESCRIPTION	QUANTITY
1*	78-416-01	Body (complete with spacer and check valve)	1
2*	13-730-01	Spool HDM10	1
3*	78-415-03	O-Ring Seal	6
4*	78-415-04	Flanged Washer HDM10	3
5*	78-415-05	Spacer	3
6*	78-415-06	A Type Spool HDS11	3
7*	78-415-11	Positioner	2
8*	78-415-08	Plug	3
9*	78-415-09	Lever Group HDS11	3
10*	78-415-10	Metric Socket Screw M5 x .8 x 45	6
11*	78-415-12	Check Valve Assembly HDM12	1
12*	78-415-13	$\frac{3}{4}$ - 16 SAE 8 Screw Plug	3
13	18-168	Elbow $\frac{3}{8}$ Straight Thread	2
14	23-011	Adapter	2
15	18-166	Adapter $\frac{1}{4}$ - $\frac{3}{8}$ SAE	4
16	78-417	Straight Handle	1
17	78-418	Bent Handle	2

* 13-730 3 – Bank Hydraulic Valve (includes all * items)

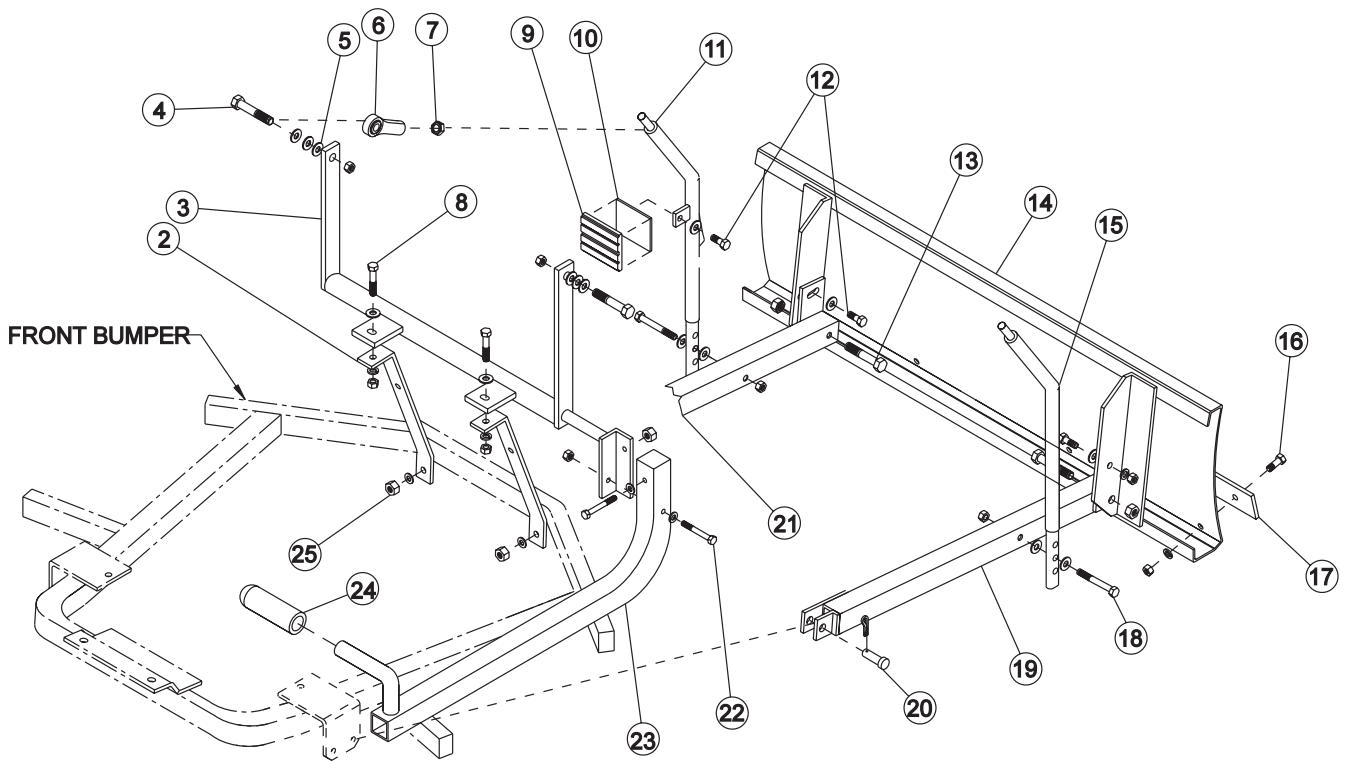

Accessories

13-644 MANUAL PLOW PARTSLIST

REF#	PART#	DESCRIPTION	QUANTITY
2	13-208	Bumper Brace	2
3	13-642	Lift Handle	1
4	HB-12-13-200	Bolt $\frac{1}{2}$ - 13 x 2	2
	HNCL-12-13	Center Lock Nut $\frac{1}{2}$ - 13	2
5	HMB-12-14	Machine Bushing $\frac{1}{2}$ x 14GA	6
6	80-006	Rod End	2
7	HNJ-12-20	Jam Nut $\frac{1}{2}$ - 20	2
8	HB-38-16-350	Bolt $\frac{3}{8}$ - 16 x $3\frac{1}{2}$	2
	HW-38	Washer $\frac{3}{8}$	2
	HNTL-38-16	Top Lock Nut $\frac{3}{8}$ - 16	2
9	15-015	Pedal Pad	1
10	16-062	Pedal Pad Plate	1
11	13-643	Left Lift Rod	1
12	HB-38-16-100	Bolt $\frac{3}{8}$ - 16 x 1	2
	HW-38	Washer $\frac{3}{8}$	2
	HWL-38	Lock Washer $\frac{3}{8}$	2
	HN-38-16	Nut $\frac{3}{8}$ - 16	2
13	HB-12-13-275	Bolt $\frac{1}{2}$ - 13 x $2\frac{3}{4}$	2
	HNCL-12-13	Center Lock Nut $\frac{1}{2}$ - 13	2
14	27-017	Sand Plow Blade	1
15	27-073	Right Lift Rod	1
16	HB-38-16-100	Bolt $\frac{3}{8}$ - 16 x 1	4
	HNFL-38-16	Flange Whiz Lock Nut $\frac{3}{8}$ - 16	4
17	13-167	Wear Blade	1
18	HB-38-16-300	Bolt $\frac{3}{8}$ - 16 x 3	2
	HW-38	Washer $\frac{3}{8}$	4
	HNTL-38-16	Lock Nut $\frac{3}{8}$ - 16	2
19	13-169	Right Pusher Bar	1
20	HCP-12-150	Clevis Pin	2
	HHP-18	Bridge Pin $\frac{1}{8}$	2
21	13-168	Left Pusher Bar	1
22	HB-516-18-225	Bolt $\frac{5}{16}$ - 18 x $2\frac{1}{4}$	2
	HW-516	Washer $\frac{5}{16}$	2
	HNTL-516-18	Lock Nut $\frac{5}{16}$ - 18	2
23	13-645	Handle	1
24	15-019	Hand Grip	1
25	HB-38-16-250	Bolt $\frac{3}{8}$ - 16 x $2\frac{1}{2}$	2
	HW-38	Washer $\frac{3}{8}$	2
	HNTL-38-16	Top Lock Nut $\frac{3}{8}$ - 16	2



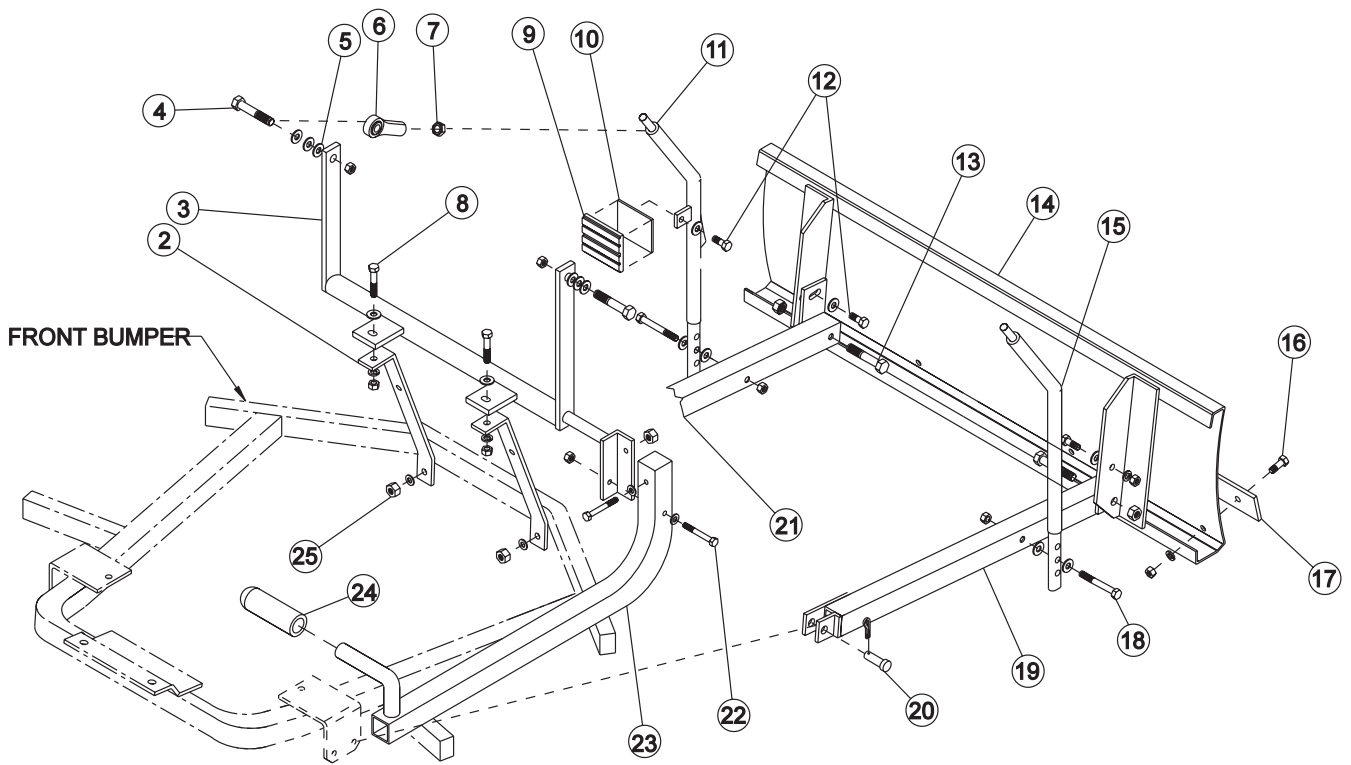

Accessories

1. Disconnect the negative (-) ground battery cable from the battery.
2. Remove the four tapping screws holding the console cover to the console and remove the cover.
3. Remove the nuts from bolts (Ref 8). To hold the bolts you will have to go through the opening in the console. Remove hardware and bumper brace (Ref 25 and 2).
4. Place the tabs on lift handle (Ref 3) over the bolts (Ref 8) and the angle on the lift handle to the right side of the machine. Next put bumper brace over the bolts with a washer and a center lock nut. Leave hardware loose at this time. Put Hardware (Ref 25) back through the bumper and bumper brace. Tighten all four bolts at this time.
5. Replace the console cover.
6. Bolt handle (Ref 23) to lift handle (Ref 3) using bolts, washers and lock nuts (Ref 22).
7. Put hand grip (Ref 24) onto the handle.
8. Assemble pusher bars (Ref 19 and 21) to plow (Ref 13) using hardware (Ref 14 and 15). There are two holes to bolt hardware (Ref 15) in. Using hole closest to the blade will result in a shallow cut, whereas using the hole furthest from the blade will result in a deeper cut. The slot on the pusher bar is for a more fine tuned adjustment.
9. Put pedal pad and pedal pad plate (Ref 9 and 10) into left lift rod (Ref 11) using hardware (Ref 15).
10. Put rod ends (Ref 6) onto lift rods (Ref 11 and 12) with jam nuts (Ref 7) first. Adjust to equal lengths. Bolt lift rods (the one with the pedal to the left side of the machine) to lift arms with the ball joints to the outside. Bolt from the outside with hardware (Ref 4) with 3 1/2" machine bushing between each rod end and lift arm.
11. Check to make sure level to hard surface after final assembly.
12. Slide plow under machine and connect to machine as shown. Use clevis pin and cotter pin (Ref 20).
13. Connect lift rods (Ref 11 and 12) to pusher bars (Ref 19 and 21) using hardware (Ref 18) as shown. The three holes in the lift rods are for adjusting the position of the hand lever. The top hole moves the lever forward and holds the blade with the most clearance. Each hole down moves the lever to the rear of the machine and decreases blade clearance by approximately one inch.
14. Reconnect the negative (-) ground battery cable to the battery.

13-678 CASTOR WHEEL KIT DRAWING

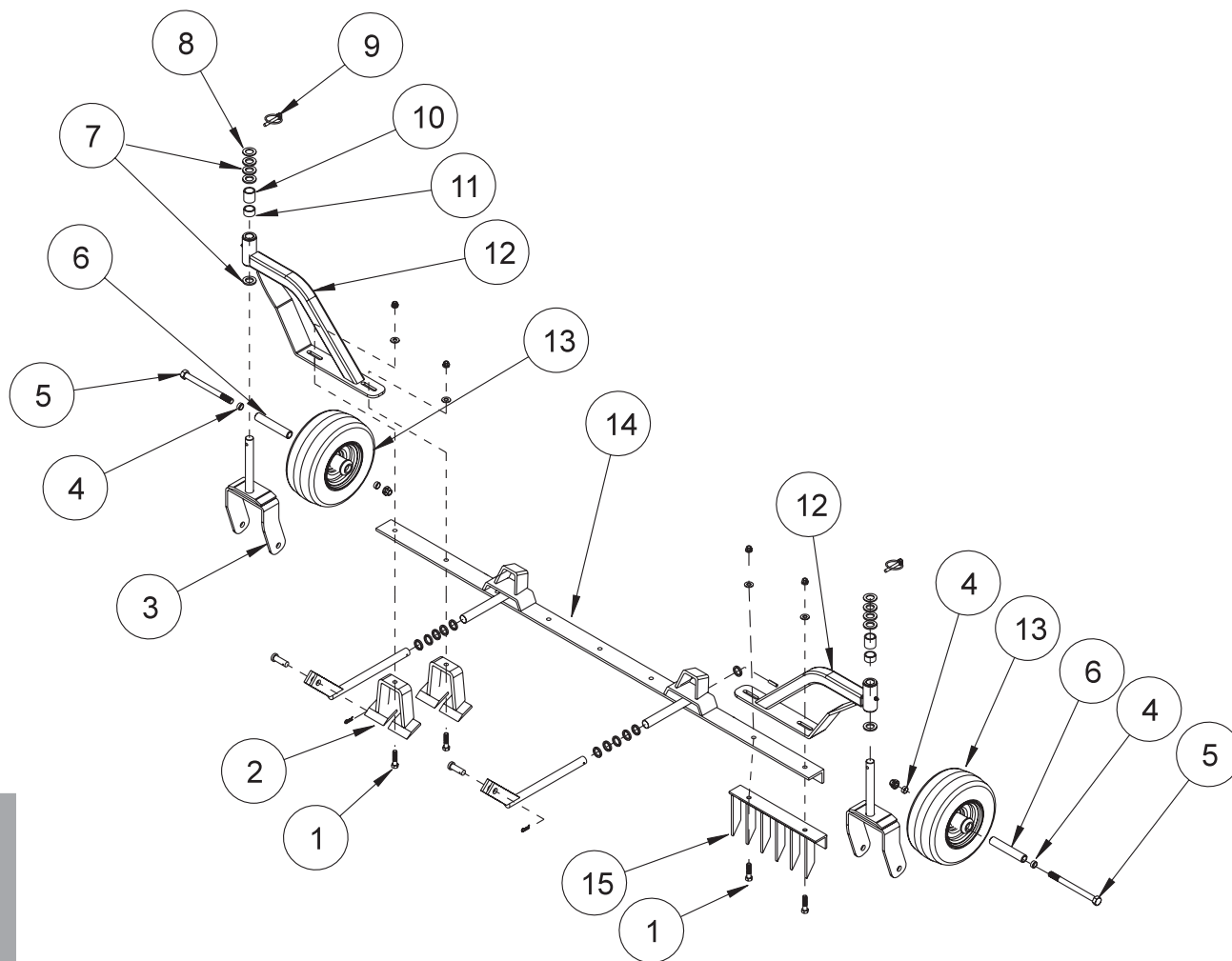

Accessories

13-678 CASTOR WHEEL KIT PARTSLIST

REF#	PART#	DESCRIPTION	QUANTITY
1	HB-38-16-150	Bolt $\frac{3}{8}$ -16 x $1\frac{1}{2}$	4
	HW-38	Washer $\frac{3}{8}$	4
	HNTL-38-16	Lock Nut $\frac{3}{8}$ -16	4
2	13-114	Digger Blade (part of 13-107)	
3	42-204	Castor Fork	2
4	42-212	Castor Wheel Spacer	4
5	HB-12-13-600	Bolt $\frac{1}{2}$ -13 x 6	2
	HNTL-12-13	Lock Nut $\frac{1}{2}$ - 13	2
6	42-213	Axle Bearing	2
7	HMB-34-10	Machine Bushing $\frac{3}{4}$ x 10 GA	8
8	HMB-34-14	Machine Bushing $\frac{3}{4}$ x 14 GA	2
9	42-539	Lynch Pin $\frac{5}{16}$	2
10	42-214	Long Spacer	2
11	42-215	Short Spacer	2
12	13-675	Castor Wheel Bracket	2
	18-221	Flange Bushing (part of 13-675)	4
	HG-14-28-180	Grease Fitting (part of 13-675)	2
13	42-202	Tire & Wheel	2
14	13-113	Frame (part of 13-107)	
	13-578	Frame (part of 13-577)	
15	26-042	Tine Segment (part of 13-577)	

INSTALLATION INSTRUCTIONS

1. Remove the two outside bolts from each end and replace with $\frac{3}{8}$ -16 x $1\frac{1}{2}$ bolts (Ref 1) with the castor wheel bracket (Ref 12) on top of the frame (Ref 14) and a washer $\frac{3}{8}$ and lock nut $\frac{3}{8}$ -16 tighten.
2. Place a $\frac{3}{4}$ x 10 GA machine bushing (Ref 7) onto the caster fork shaft (Ref 3) first. Adjust castor wheels by placing the short (Ref 11) or long (Ref 10) spacers on the castor wheel fork before placing the castor wheel assembly into the castor wheel brackets. Slide the shaft up through the castor wheel bracket sleeve. Place spacer(s) not used on the bottom, on the top then add three $\frac{3}{4}$ x 10 GA machine bushings and one $\frac{3}{4}$ x 14 GA machine bushing (Ref 8) onto the castor fork shaft. Hold in place with a lynch pin (Ref 9). You may use any combination of spacers and machine bushings, as long as you start and end with a machine bushing. Be sure both castor wheels are adjusted to the same height.
3. Grease the fittings on the castor wheel bracket sleeves.
4. Turn the machine on and test for proper operation.

13-107 SCARIFIER WITH CHISEL BLADES DRAWING

To be used with 13-107 Scarifier with Chisel Blades and 13-577 Scarifier with Vertical Blades

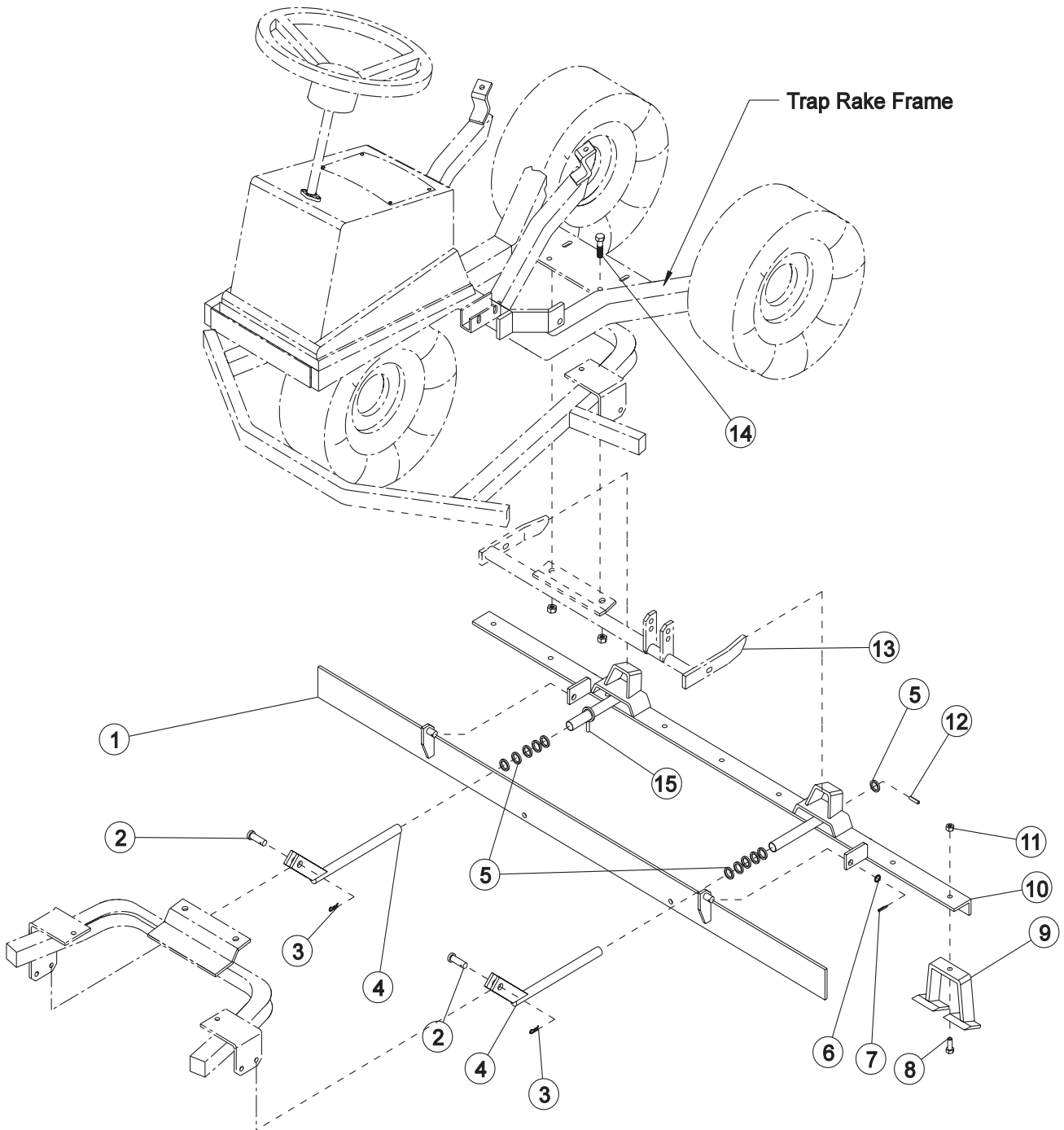

Accessories

13-107 SCARIFIER WITH CHISEL BLADES PARTS LIST

To be used with 13-107 Scarifier with Chisel Blades and 13-577 Scarifier with Vertical Blades

REF#	PART#	DESCRIPTION	QUANTITY
1	13-117	Grader Blade	1
2	HCP-12-150	Clevis Pin $\frac{1}{2}$ x $1\frac{1}{2}$	2
3	HHP-18	Bridge Pin $\frac{1}{8}$	3
4	13-115	Hitch (Pistols)	2
5	HMB-34-10	Machine Bushing $\frac{3}{4}$ x 10GA	12
6	HMB-12-14	Machine Bushing $\frac{1}{2}$ x 14GA	4
7	HP-18-100	Cotter Pin $\frac{1}{8}$ x 1	1
8	HB-38-16-100	Bolt $\frac{3}{8}$ - 16 x 1	9
9	13-114	Digger Blade	9
10	13-113	Frame	1
11	HNCL-38-16	Center Lock Nut $\frac{3}{8}$ - 16	9
12	HRP-14-100	Roll Pin $\frac{1}{4}$ x 1	2
13	Attachment Lift (part of Lift Assembly)		
14	HB-716-14-150	Bolt $\frac{7}{16}$ - 14 x $1\frac{1}{2}$	2
	HNTL-716-14	Lock Nut $\frac{7}{16}$ -14	2
15	19-217	Transportation Hook	1

INSTALLATION INSTRUCTIONS

Optional Lift Assembly 13-505 must be installed before installing this unit on Super 2.

- Slide the transportation hook over the right tube of the frame (Ref 2). Insert bridge pin (Ref 12) in hook for use when required later.
- Using nine bolts (Ref 10) and nuts (Ref 7) attach digger blades (Ref 8) to frame.
- Insert hitch (pistols) (Ref 13) into tubes of frame with up to five machine bushings (Ref 5) in front and one bushing in the rear of tube. Secure pistols with roll pins (Ref 6). Check spacing before driving in roll pin all the way. For more tire clearance, machine bushings may be moved from front to rear.
- Attach grader blade (Ref 1) to frame (Ref 2) as shown using machine bushing (Ref 9) and cotter pin (Ref 11).
- Lift grader blade/frame unit (Ref 1 and 2) and hook pockets over the arms of attachment lift (Ref 4).
- Attach pistols to the tabs of the trap rake frame undercarriage in the rear holes using clevis pins (Ref 14), machine bushings (Ref 12) and bridge pins (Ref 14).
- Turn machine on and test for proper operation.

13-577 SCARIFIER VERTICAL BLADES DRAWING

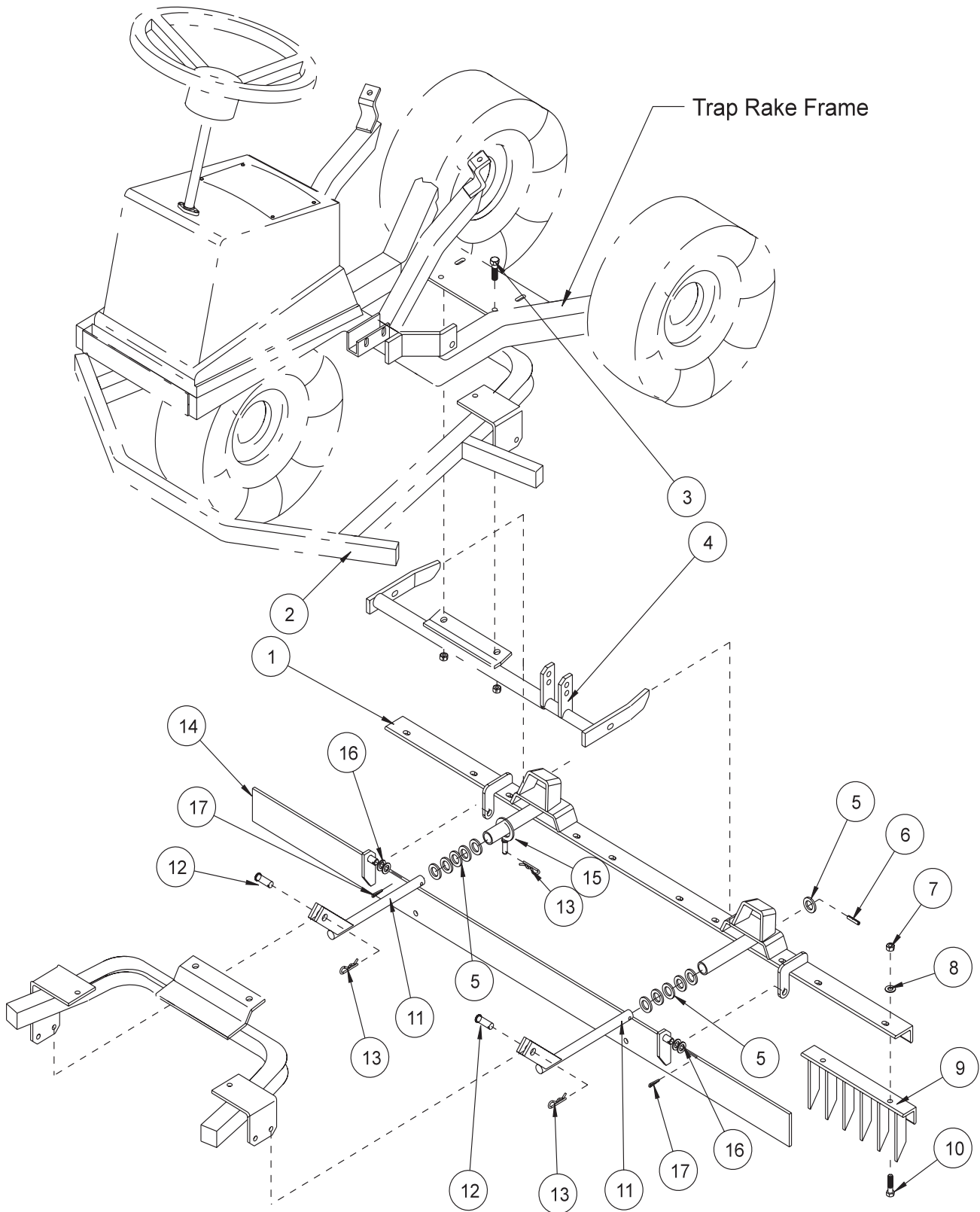

Accessories

13-577 SCARIFIER VERTICAL BLADES PARTS LIST

REF#	PART#	DESCRIPTION	QUANTITY
1	13-578	Frame	1
2		Main Frame (Part of Trap Rake)	
3	HB-716-14-150	Bolt $7/16$ -14 x $1\frac{1}{2}$	2
	HNTL-716-14	Lock Nut $7/16$ -14	2
4		Attachment Lift (part of Lift Assembly)	1
5	HMB-34-10	Machine Bushing $3/4$ x 10GA	12
6	HRP-14-100	Roll Pin $1/4$ x 1	2
7	HN-38-16	Nut $3/8$ - 16	10
8	HWL-38	Lockwasher $3/8$	10
9	26-042	Tine Segment	5
10	HB-38-16-100	Bolt $3/8$ - 16 x 1	10
11	13-115	Hitch (Pistols)	2
12	HCP-12-150	Clevis Pin $1/2$ x $1\frac{1}{2}$	2
13	HHP-18	Bridge Pin $1/8$	3
14	13-117	Grader Blade	1
15	19-217	Hook	1
16	HMB-12-14	Machine Bushing $1/2$ x 14GA	4
17	HP-18-100	Cotter Pin $1/8$ x 1	2

INSTALLATION INSTRUCTIONS

Optional Lift Assembly 13-505 must be installed before installing this unit on Super 2

1. Bolt five tine segments (Ref 9) to frame (Ref 1) using ten bolts, lockwashers and nuts (Ref 7, 8 and 10) as shown on drawing.
2. Put hook (Ref 15) over right hand tube on frame (Ref 1). Hook is to used to hold grader blade up when not in use.
3. Insert hitch (pistols) (Ref 11) into tubes of main frame with up to five machine bushings (Ref# 5) in front and one bushing in rear of the tube. Secure pistols with roll pins (Ref# 6). Check the spacing before driving roll pin in all the way. For more tire clearance, machine bushings may be moved from front to rear.
4. Put the grader blade (Ref 14) on as shown using two bridge pins (Ref 13).
5. Lift up frame (Ref 1) and hook pockets over the arms of attachment lift (Ref 4).
6. Attach pistols to the tabs of the trap rake frame undercarriage in the rear holes using clevis pins (Ref 12) and bridge pins (Ref 13).
7. Turn machine on and test for proper operation.

13-116 SAND CULTIVATOR DRAWING

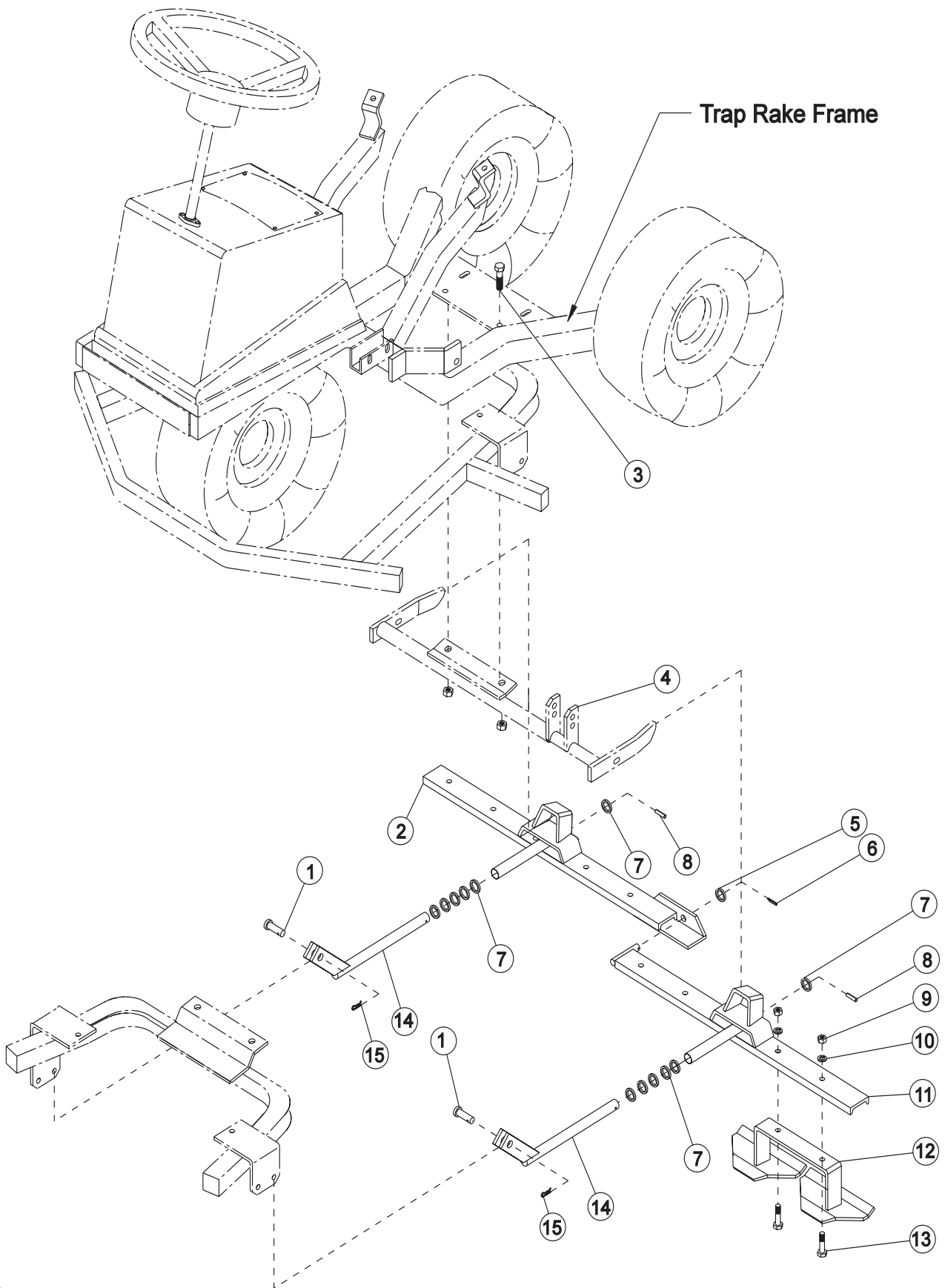

Accessories

13-116 SAND CULTIVATOR PARTSLIST

REF#	PART#	DESCRIPTION	QUANTITY
1	HCP-12-150	Clevis Pin $\frac{1}{2}$ x $1\frac{1}{2}$	2
2	13-121	Right Frame Cultivator	1
3	HB-716-14-150	Bolt $\frac{7}{16}$ - 14 x $1\frac{1}{2}$ (Part of Trap Rake)	2
	HNTL-716-14	Lock Nut $\frac{7}{16}$ - 14 (Part of Trap Rake)	2
4		Attachment Lift (part of Lift Assembly)	1
	HSSQ-38-16-200	Square Head Set Screw $\frac{3}{8}$ -16 x 2	1
	HN-38-16	Nut $\frac{3}{8}$ - 16	1
	HB-38-16-125	Bolt $\frac{3}{8}$ - 16 x $1\frac{1}{4}$	1
	HW-38	Washer $\frac{3}{8}$	1
	HNTL-38-16	Lock Nut $\frac{3}{8}$ - 16	1
5	HMB-12-14	Machine Bushing $\frac{1}{2}$ x 14GA	1
6	HP-18-100	Cotter Pin $\frac{1}{8}$ x 1	1
7	HMB-34-10	Machine Bushing $\frac{3}{4}$ x 10GA	12
8	HRP-14-100	Roll Pin $\frac{1}{4}$ x 1	2
9	HN-38-16	Nut $\frac{3}{8}$ - 16	8
10	HWL-38	Lockwasher $\frac{3}{8}$	8
11	13-120	Left Frame Cultivator	1
12	13-096	Blade	4
13	HB-38-16-125	Bolt $\frac{3}{8}$ - 16 x $1\frac{1}{4}$	8
14	13-115	Hitch (Pistols)	2
15	HHP-18	Bridge Pin $\frac{1}{8}$	2

INSTALLATION INSTRUCTIONS

Optional Lift Assembly 13-505 must be installed before installing this unit on Super 2

1. Attach (Ref 11 and 2) cultivator frames together at center pin using (Ref 5) machine bushings and (Ref 6) cotter pin.
2. Bolt four (Ref 12) blade assemblies to frames using eight (Ref 13) bolts, (Ref 10) lockwashers and (Ref 9) nuts. The blade points should angle down and forward.
3. Insert (Ref 14) hitch, (pistols) into tubes of frames ((Ref 11 and 2) with up to five (Ref 7) bushings in front and one bushing in the rear of tube. Secure pistols with (Ref 8) roll pins. Check spacing before driving roll pin in all the way. For more tire clearance, the machine bushing may be moved from front to rear.
4. Slide pockets of cultivator frames over arms of (Ref 4) attachment lift.
5. Hook pistols up to tabs under trap rake frame by using rear holes with (Ref 1) clevis pins and (Ref 15) bridge pin.
6. Start engine to test operation of cultivator. Raise and lower attachment checking for leaks and to see whether they are fairly level.

13-199 EDGER KIT DRAWING

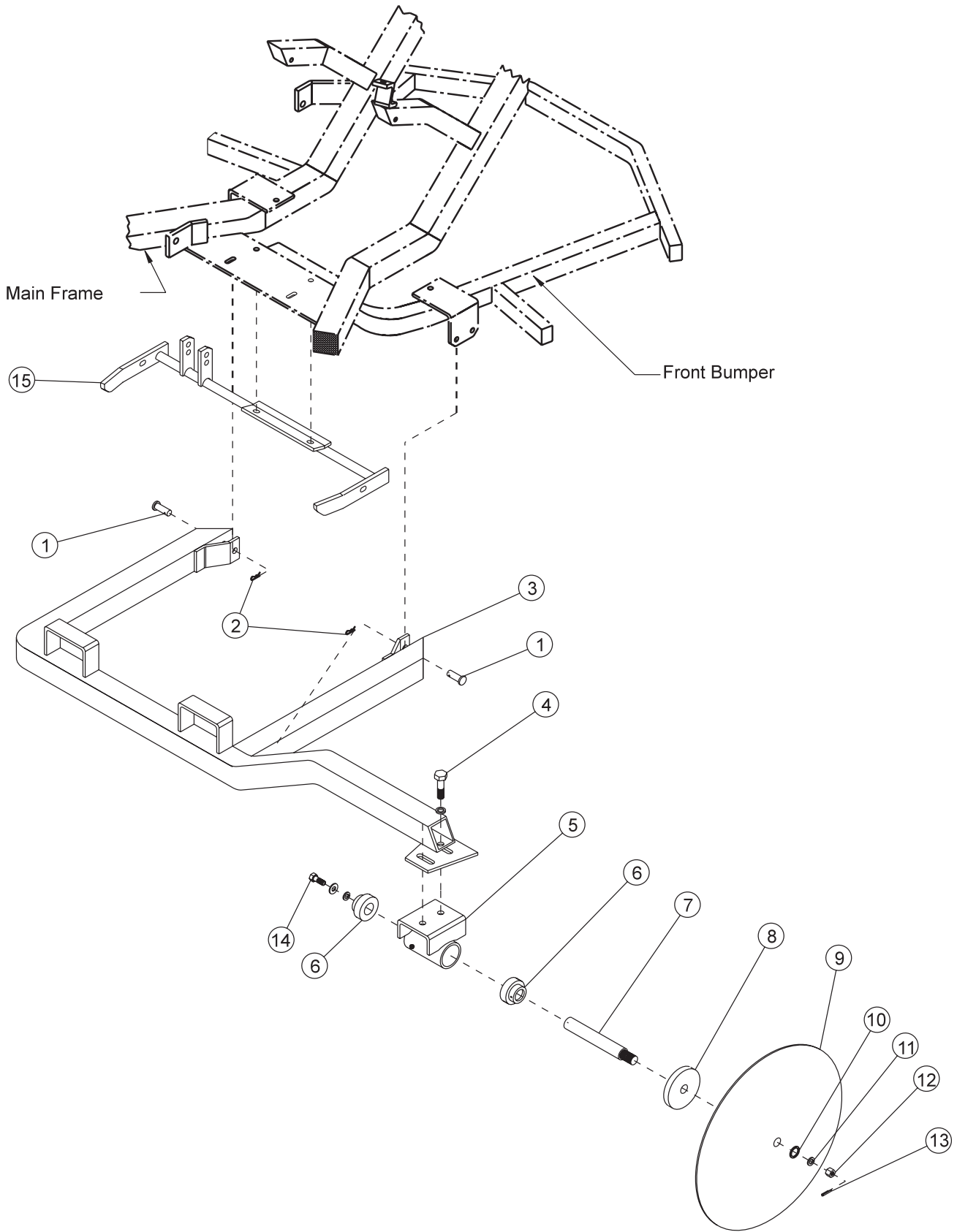

Accessories

13-199 EDGER KIT PARTS LIST

REF#	PART#	DESCRIPTION	QUANTITY
1	HCP-12-150	Clevis Pin, $\frac{1}{2} \times 1\frac{1}{2}$	2
2	HHP-18	Bridge Pin, $\frac{1}{8}$	2
3	13-200	Edger Frame	1
4	HB-12-13-150	Bolt $\frac{1}{2}$ - 13 x $1\frac{1}{2}$	2
	HW-12	Washer $\frac{1}{2}$	2
	HWL-12	Lockwasher $\frac{1}{2}$	2
	HN-12-13	Nut $\frac{1}{2}$ - 13	2
5	13-203	Spindle Tube	1
	HG-14-28-180	Grease Fitting $\frac{1}{4}$ - 28 x 180°	1
6	21-169	Bearing & Collar	2
7	13-206	Spindle Shaft	1
8	13-205	$\frac{1}{2}$ Disc Flange	1
9	13-204	Disc	1
10	HMB-34-14	Machine Bushing $\frac{3}{4} \times 14$ GA	2
11	HWL-34	Lockwasher $\frac{3}{4}$	1
12	HNA-34-16	Axle nut $\frac{3}{4}$ - 16	1
13	HP-18-150	Cotter Pin $\frac{1}{8} \times 1\frac{1}{2}$	1
14	HB-38-16-100	Bolt $\frac{3}{8}$ - 16 x 1	1
	HWL-38	Lockwasher $\frac{3}{8}$	1
	HW-516	Washer $\frac{5}{16}$	1
	HW-716	Washer $\frac{7}{16}$	1
15		Attachment Lift (Part of Lift Assembly)	
16		Main Frame (Part of Trap Rake)	

INSTALLATION INSTRUCTIONS

Optional Lift Assembly 13-505 must be installed before installing this unit on Super 2

- For initial assembly, bolt spindle tube (Ref 5) to edger frame (Ref 3) at a 60° to 70° angle. Use bolts, washers and nuts (Ref 4).
- Next, make sure $\frac{1}{2}$ " thick by $3\frac{1}{2}$ " round spacer (Ref 8) is on spindle shaft up to shoulder. Then place disc (Ref 9) onto the shaft followed by two $\frac{3}{4}$ machine bushings (Ref 10), one $\frac{3}{4}$ lockwasher and one $\frac{3}{4}$ - 16 axle nut (Ref 12). Tighten nut and use $\frac{1}{8} \times 1\frac{1}{2}$ cotter pin (Ref 13) to lock it.
- The edger unit mounts under the center of trap rake, fastening to attachment lift assembly, 13-146.
- Start engine and lower attachment lift FULLY. Stop engine.
- Slide edger unit under trap rake from right side.
- Position lift brackets (pockets) of edger on lift bars, both sides at once or one side at a time if only one person is working on this.
- Start engine again and raise lift bars until horizontal with ground. Stop engine.
- Slide edger frame arms forward until holes of arms match rear holes of attachment bracket on main frame of trap rake. Secure them with two each; $\frac{1}{2} \times 1\frac{1}{2}$ clevis pins and $\frac{1}{8}$ bridge pins.
- Start engine and test lift and edger to make sure that all works well.
- To remove edger, lower lift until horizontal, undo the clevis and bridge pins, and slide edger off lift arms. Use CAUTION when releasing unit so it will not come down too fast on anyone's toes, fingers or legs.

13-111 DRAG MAT KIT DRAWING

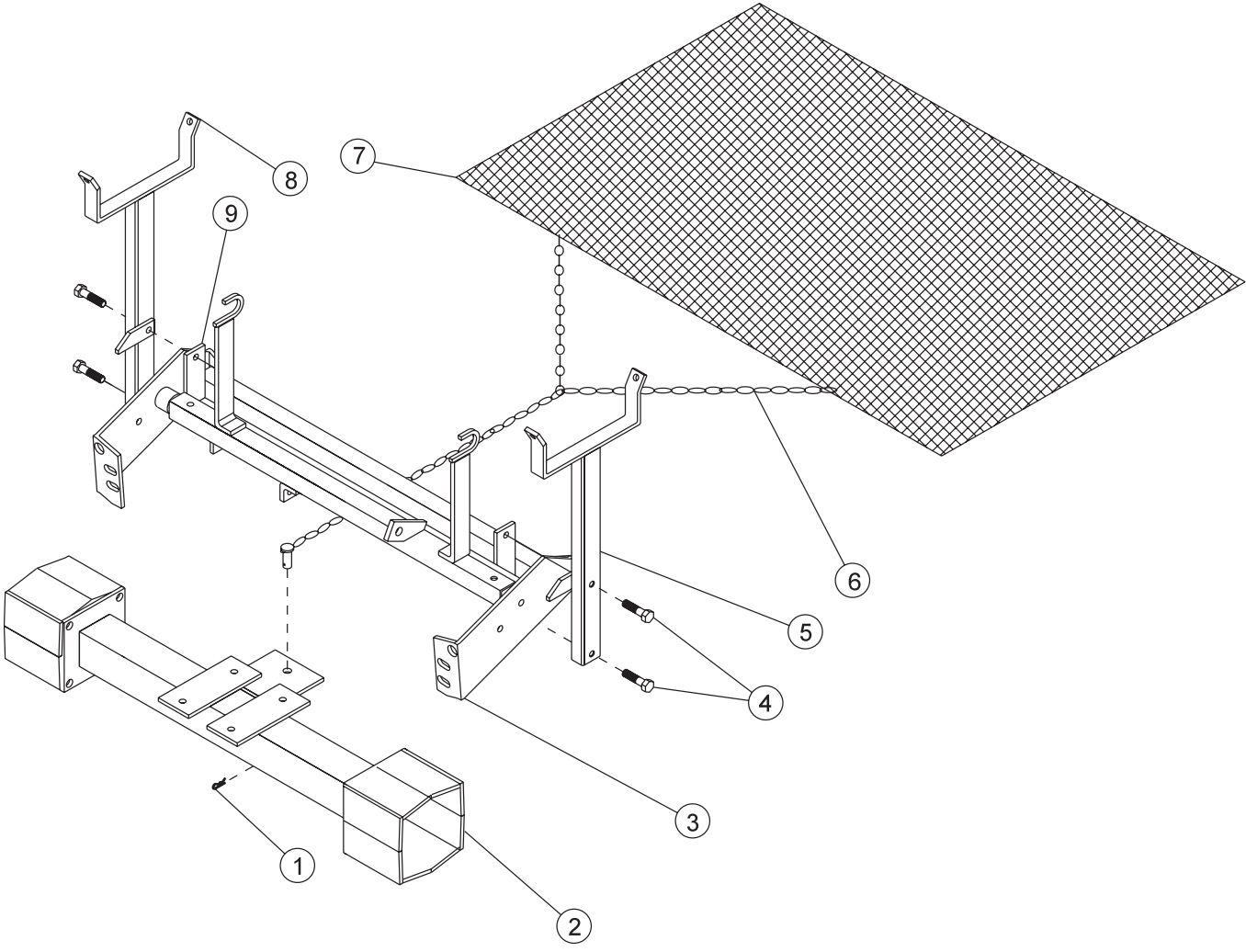

Accessories

13-111 DRAG MAT KIT DRAWING

REF#	PART#	DESCRIPTION	QUANTITY
1	HHP-18	Bridge Pin 1/8	1
2		Hitch (Part of Trap Rake)	1
3		Rake Lift (Part of Trap Rake)	1
4*	HB-38-16-225	Bolt 3/8 - 16 x 2 1/4	4
	HWL-38	Lockwasher 3/8	4
	HN-38-16	Nut 3/8 - 16	4
5*	13-195	Left Mat Carrier Post	1
6	19-605	Drag Mat Chain	1
7	19-601	Drag Mat	1
8*	13-156	Right Mat Carrier Post	1
9*	13-157	Carrier Lock Strap	2
*	13-112	Carrier Kit, posts with hardware (includes all * items)	1

INSTALLATION INSTRUCTIONS

1. Looking from the rear of the trap rake, mount the mat carrier post (Ref 8) outside the right rear corner of the rake lift with the lock strap (Ref 9) on the inside of the rake lift side plate. Bolt into place with two bolts, nuts and lockwashers (Ref 4).
2. Mount the left mat carrier (Ref 5) outside the left corner similar to the right side with the lock strap (Ref 9) to the inside.
3. To carry the mat, roll it up and place it in the brackets of the carrier posts.
4. To use the mat, unroll it flat and hook it up to the trap rake hitch with the clevis pin and bridge pin.

42-026 84" (213 CM) STAINLESS STEEL TOURNAMENT RAKE DRAWING

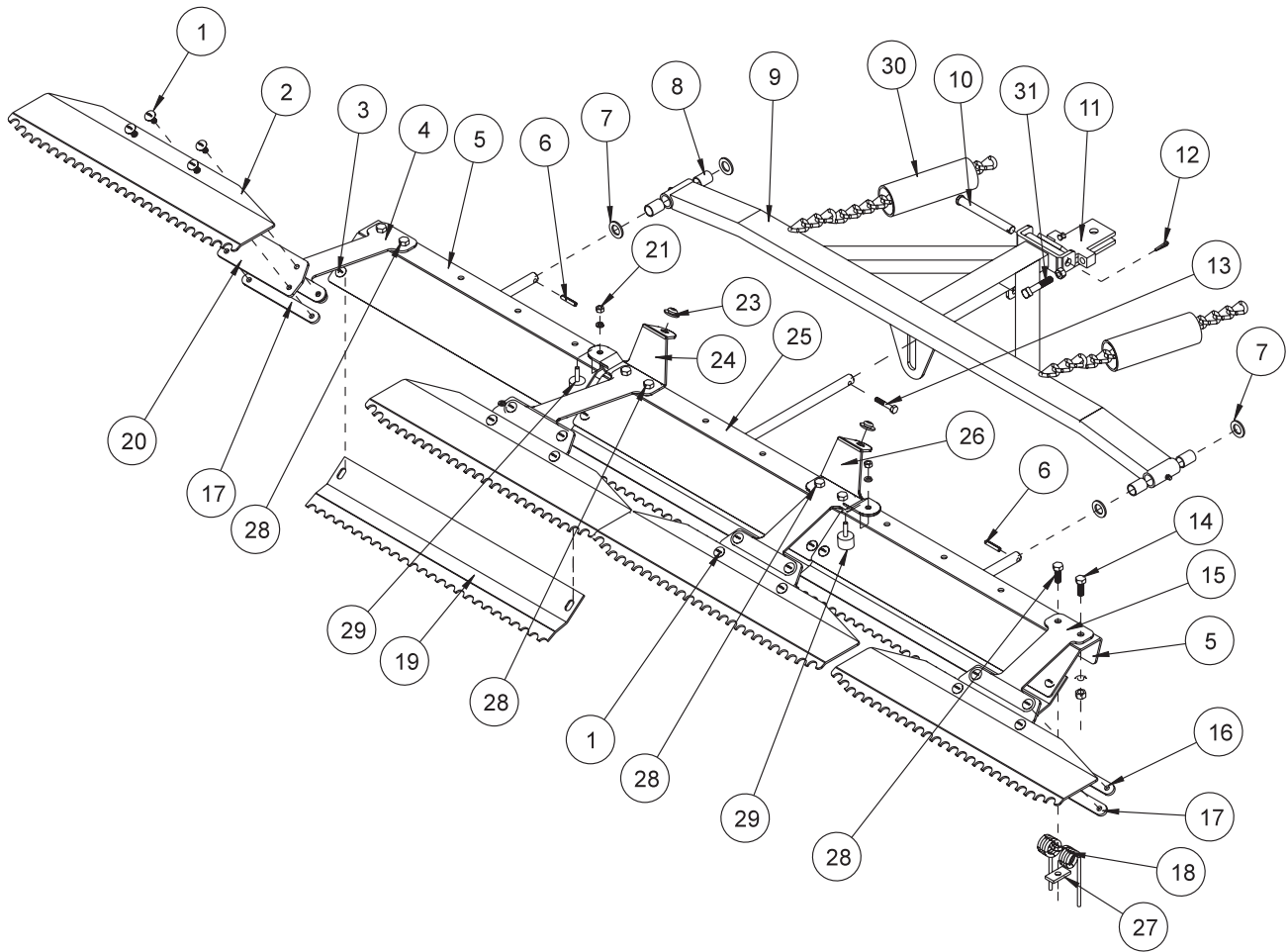

Accessories

42-02684"(213 CM) STAINLESS STEEL TOURNAMENT RAKE PARTSLIST

REF#	PART#	DESCRIPTION	QUANTITY
1	HSTPS-516-18-100	Stainless Phillip Head Screw $5/16$ - 18 x 1	16
	HWL-516	Lockwasher $5/16$	16
	HN-516-18	Nut $5/16$ - 18	16
2	42-104	Finishing Blades	4
3	HSTPS-516-18-100	Stainless Phillip Head Screw $5/16$ - 18 x 1	6
	HW-516	Washer $5/16$	6
	HWL-516	Lockwasher $5/16$	6
	HN-516-18	Nut $5/16$ - 18	6
4	42-111	Left Outside Mount	1
5	42-102	Outside Rake	2
6	HRP-14-100	Roll Pin $1/4$ x 1	2
7	HMB-58-14	Machine Bushing $5/8$ x 14GA	4
8	20-018	Oilite Bushing (comes with drawbar)	4
9	42-100	Draw Bar	1
10	HCP-12-450	Clevis Pin $1/2$ x $4 1/2$	1
11	13-647	Hitch	1
	HCP-12-150	Clevis Pin $1/2$ x $1 1/2$	1
	HHP-18	Bridge Pin $1/8$	1
12	HP-18-100	Cotter Pin $1/8$ x 1	1
13	HB-14-20-175	Bolt $1/4$ - 20 x $1 3/4$	1
	HNTL-14-20	Lock Nut $1/4$ - 20	1
14	HSTPS-516-18-125	Stainless Steel Phillips Truss Head Screw $5/16$ - 18 x $1 1/4$	4
	HWL-516	Lockwasher $5/16$	4
	HN-516-18	Nut $5/16$ - 18	4
15	42-109	Right Outside Mount	1
16	42-105	Top Strap	4
17	42-106	Bottom Strap	4
18	42-122	Rake Spring	12
19	42-103	Groomer Blades	3
20	42-107	Matting	4
21	HNC-14-20	Cap Nut $1/4$ - 20	2
	HWL-14	Lockwasher $1/4$	2
23	42-116	Rubber insert	2
24	42-110	Left Inside Mount	1
25	42-101	Center Rake	1
26	42-108	Right Inside Mount	1
27	42-177	Spring Holder	12
28	HSTPS-516-18-125	Stainless Steel Phillips Truss Head Screw $5/16$ - 18 x $1 1/4$	12
	HWL-516	Lockwasher $5/16$	12
	HN-516-18	Nut $5/16$ - 18	12
29	15-013	Rubber Bumper	2
30	8892-6	Hose Wrap $1/4$ "	2
31	HSSQ-38-16-200	Square Head Set Screw $3/8$ - 16 x 2 (comes with 13-647)	2
	HN-38-16	Nut $3/8$ - 16 (comes with 13-647)	2

42-026 84" (213CM) STAINLESS STEEL TOURNAMENT RAKE DRAWING

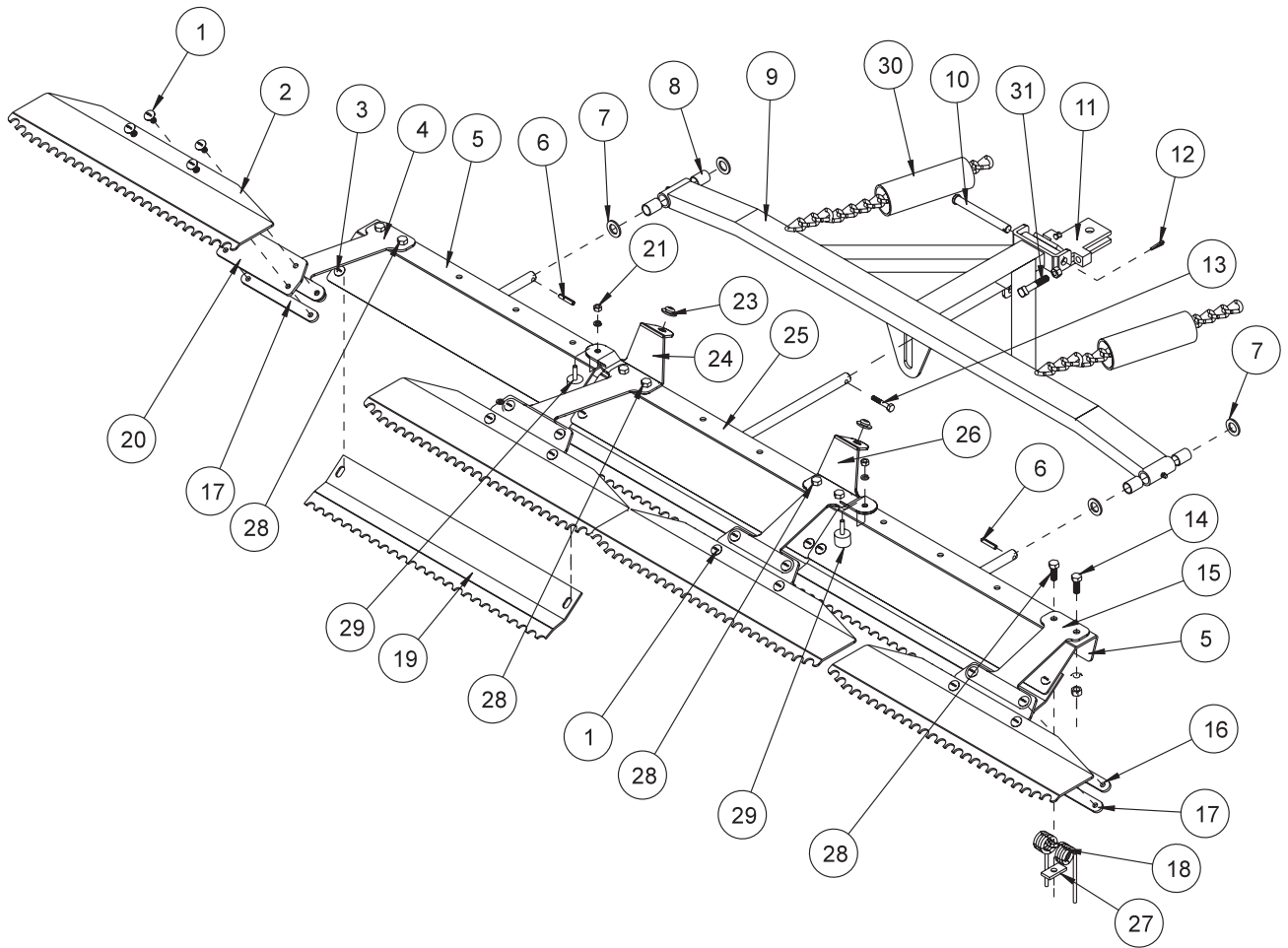

Accessories

1. Attach drawbar (Ref 9) to hitch (Ref 11) using clevis pin (Ref 10) and cotter pin (Ref 12).
2. Attach rubber bumper (Ref 29) using cap nut and lock washer (Ref 21). Attach the rubber inserts (Ref 23) to the inside mounts (Ref 24 and 26).
3. Attach the left outside mount (Ref 4), the left inside mount (Ref 24), the outside trowel mount (Ref 15), and the inside trowel mount (Ref 26) to the outside and center rakes (Ref 5 and 25) as shown. Use the 1¹/₄" stainless steel truss head screws (Ref 14) on the outside hole of each rake.
4. Use the spring holder (Ref 27) and the 1¹/₄" stainless steel truss head screws (Ref 28) to attach rake springs (Ref 18) to the rakes.
5. Slide a machine bushing onto outside rake frames then slide the outside rake frames (Ref 5) into the tubing on the end of the drawbar. Hold in place with another machine bushing and a roll pin (Ref 6).
6. Attach center rake (Ref 25) to draw bar (Ref 9) as shown, using the 1¹/₄ - 20 - 1³/₄ bolt and lock nut (Ref 13) with the shaft of the center rake between the tabs on the bottom of the drawbar.
7. Attach the matting (Ref 20) and the top strap (Ref 16) to the inside and outside mounts using stainless steel truss head screw ⁵/₁₆ - 18 x 1 (Ref 1). Attach four finishing blades (Ref 2) to the matting on the inside and outside mounts with the stainless steel truss head screw ⁵/₁₆ - 18 x 1 (Ref 1) going through the finishing blade, matting, and bottom strap (Ref 17).
8. Place the three groomer blades (Ref 19) under the three rake assemblies as shown, using (Ref 3).
9. Attach the rake hitch (Ref 11) to the trap rake hitch.
10. The end links of chain on the drawbar are to be hooked to the hooks of the trap rake lift.
11. With the rake on the ground pull the rake to the right side until it is 2-3 inches from the tire.
12. Using the adjustment screw (Ref 31) on the right side of hitch, adjust the screw until it hits the trap rake hitch, located on rear axle. Lock nut so adjustment will not change.
13. Repeat steps 8 and 9 on left side.
14. Turn machine on and test for operation of rake assembly by raising and lowering the rake assembly. Also with rake down, turn sharp corners to check that rake does not touch wheels.

NOTE: Test rake in sand to assure tire tracks are covered by the rake when turning sharp corners in either direction. If there are tire tracks, readjust using the adjusting screws on the hitch, so the rake comes closer to the tire.

42-128 72" (183CM) STAINLESS STEEL TOURNAMENT RAKE DRAWING

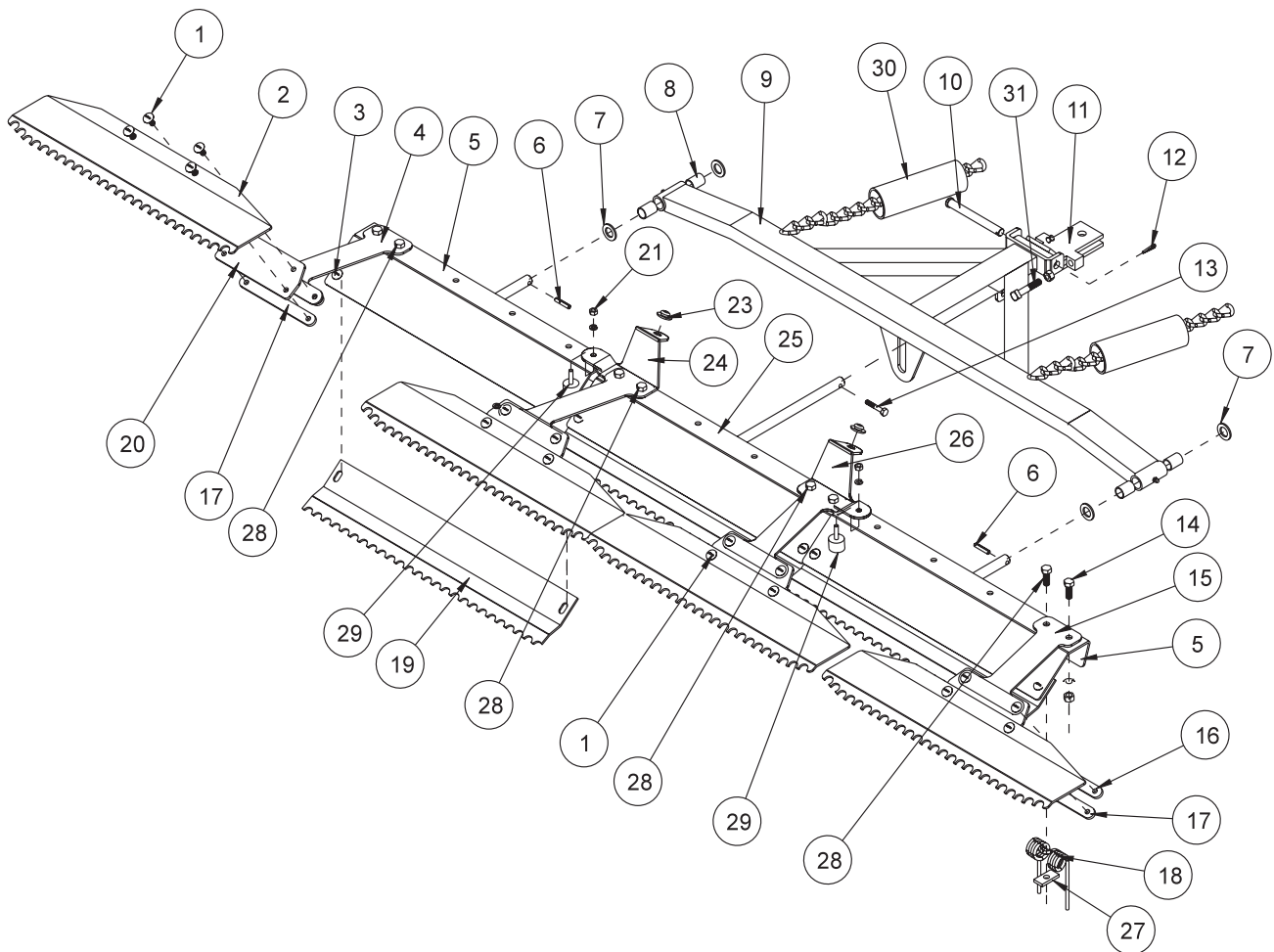

Accessories

42-128 72" (183CM) STAINLESS STEEL TOURNAMENT RAKE PARTS LIST

REF#	PART#	DESCRIPTION	QUANTITY
1	HSTS-516-18-100	Stainless Steel Truss Head Screw $5/16$ - 18 x 1	16
	HWL-516	Lock Washer $5/16$	16
	HN-516-18	Nut $5/16$ - 18	16
2	42-137	Finishing Blades	4
3	HSTPS-516-18-100	Stainless Phillip Head Screw $5/16$ - 18 x 1	6
	HW-516	Washer $5/16$	6
	HWL-516	Lock Washer $5/16$	6
	HN-516-18	Nut $5/16$ - 18	6
4	42-111	Left Outside Mount	1
5	42-140	Outside Rake	2
6	HRP-14-100	Roll Pin $1/4$ x 1	2
7	HMB-58-14	Machine Bushing $5/8$ x 14GA	4
8	20-018	Oilite Bushing (comes with 42-141)	4
9	42-141	Draw Bar	1
10	HCP-12-450	Clevis Pin $1/2$ x $4 1/2$	1
11	13-647	Hitch	1
	HCP-12-150	Clevis Pin $1/2$ x $1 1/2$	1
	HHP-18	Bridge Pin $1/8$	1
12	HP-18-100	Cotter Pin $1/8$ x 1	1
13	HB-14-20-175	Bolt $1/4$ - 20 x $1 3/4$	1
	HNTL-14-20	Lock Nut $1/4$ - 20	1
14	HSTPS-516-18-125	Stainless Steel Phillips Truss Head Screw $5/16$ - 18 x $1 1/4$	4
	HWL-516	Lock Washer $5/16$	4
	HN-516-18	Nut $5/16$ - 18	4
15	42-109	Outside Trowel Mount	1
16	42-105	Top Strap	4
17	42-106	Bottom Strap	4
18	42-122	Rake Spring	12
19	42-138	Groomer Blades	3
20	42-107	Matting	4
21	HNC-14-20	Cap Nut $1/4$ - 20	2
	HWL-14	Lock Washer $1/4$	2
23	42-116	Rubber Insert	2
24	42-110	Left Inside Mount	1
25	42-139	Center Rake	1
26	42-108	Inside Trowel Mount	1
27	42-177	Spring Holder	12
28	HSTPS-516-18-125	Stainless Steel Phillips Truss Head Screw $5/16$ - 18 x $1 1/4$	12
	HWL-516	Lock Washer $5/16$	12
	HN-516-18	Nut $5/16$ - 18	12
29	15-013	Rubber Bumper	2
30	8892-6	Hose Wrap	2
31	HSSQ-38-16-200	Square Head Set Screw $3/8$ - 16 x 2 (comes with 13-647)	2
	HN-38-16	Nut $3/8$ - 16 (comes with 13-647)	2

42-128 72" (183CM) STAINLESS STEEL TOURNAMENT RAKE DRAWING

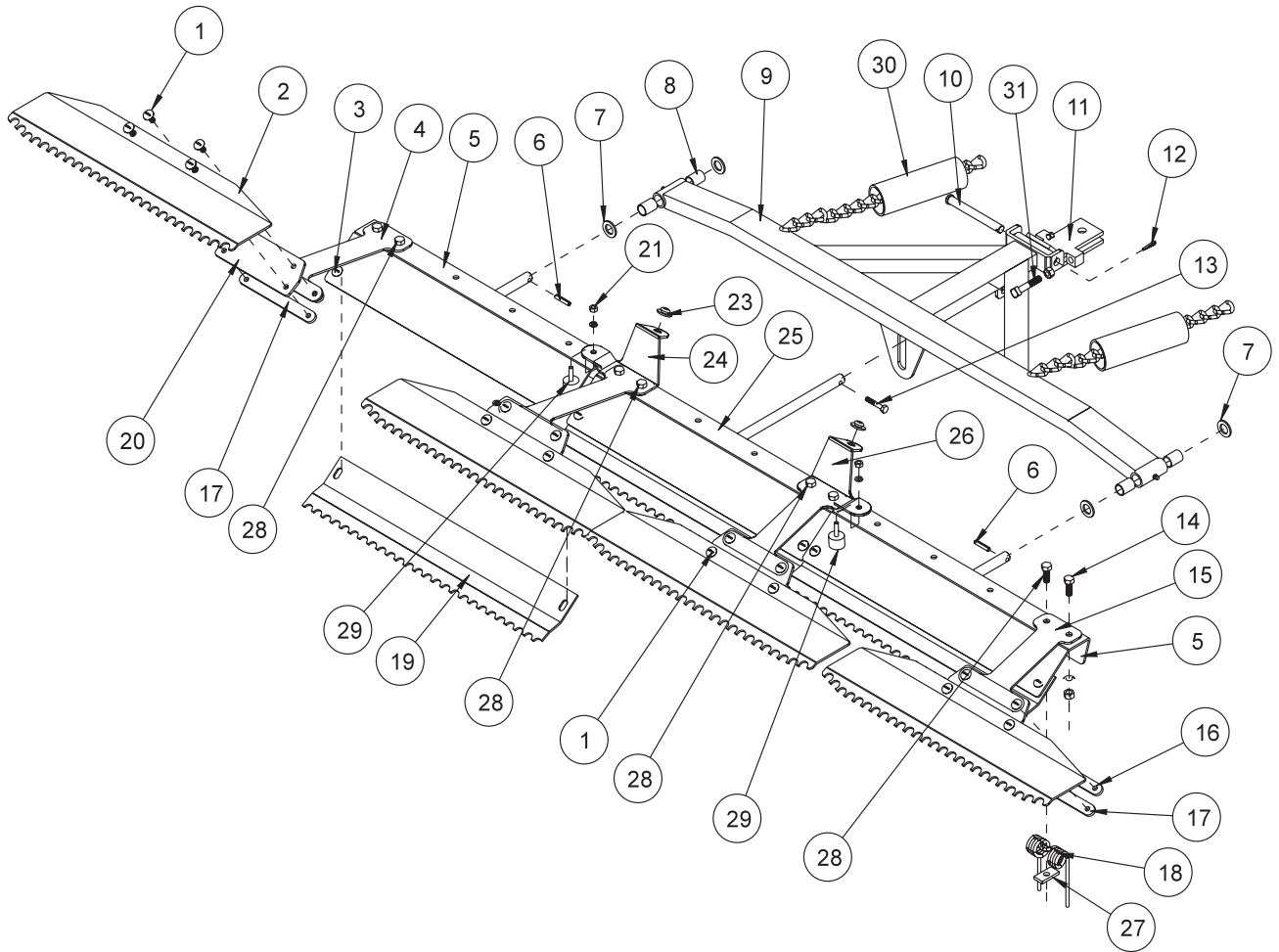

Accessories

INSTALLATION INSTRUCTIONS

1. Attach drawbar (Ref 9) to hitch (Ref 11) using clevis pin (Ref 10) and cotter pin (Ref 12).
 2. Attach rubber bumper (Ref 29) using cap nut and lock washer (Ref 21). Attach the rubber inserts (Ref 23) to the inside mounts (Ref 24 and 26).
 3. Attach the left outside mount (Ref 4), the left inside mount (Ref 24), the outside trowel mount (Ref 15), and the inside trowel mount (Ref 26) to the outside and center rakes (Ref 5 and 25) as shown. Use the 1¹/₄" stainless steel truss head screws (Ref 14) on the outside hole of each rake.
 4. Use the spring holder (Ref 27) and the 1¹/₄" stainless steel truss head screws (Ref 28) to attach rake springs (Ref 18) to the rakes.
 5. Slide a machine bushing onto outside rake frames then slide the outside rake frames (Ref 5) into the tubing on the end of the drawbar. Hold in place with another machine bushing and a roll pin (Ref 6).
 6. Attach center rake (Ref 25) to draw bar (Ref 9) as shown, using the 1¹/₄ - 20 - 1³/₄ bolt and lock nut (Ref 13) with the shaft of the center rake between the tabs on the bottom of the drawbar.
 7. Attach the matting (Ref 20) and the top strap (Ref 16) to the inside and outside mounts using stainless steel truss head screw ⁵/₁₆ - 18 x 1 (Ref 1). Attach four finishing blades (Ref 2) to the matting on the inside and outside mounts with the stainless steel truss head screw ⁵/₁₆ - 18 x 1 (Ref 1) going through the finishing blade, matting, and bottom strap (Ref 17).
 8. Place the three groomer blades (Ref 19) under the three rake assemblies as shown, using (Ref 3).
 9. Attach the rake hitch (Ref 11) to the trap rake hitch.
 10. The end links of chain on the drawbar are to be hooked to the hooks of the trap rake lift.
 11. With the rake on the ground pull the rake to the right side until it is 2-3 inches from the tire.
 12. Using the adjustment screw (Ref 31) on the right side of hitch, adjust the screw until it hits the trap rake hitch, located on rear axle. Lock nut so adjustment will not change.
 13. Repeat steps 8 and 9 on left side.
 14. Turn machine on and test for operation of rake assembly by raising and lowering the rake assembly. Also with rake down, turn sharp corners to check that rake does not touch wheels.
- NOTE:** Test rake in sand to assure tire tracks are covered by the rake when turning sharp corners in either direction. If there are tire tracks, readjust using the adjusting screws on the hitch, so the rake comes closer to the tire.

13-438 RAKE ASSEMBLY WITH FINISHING BLADES DRAWING

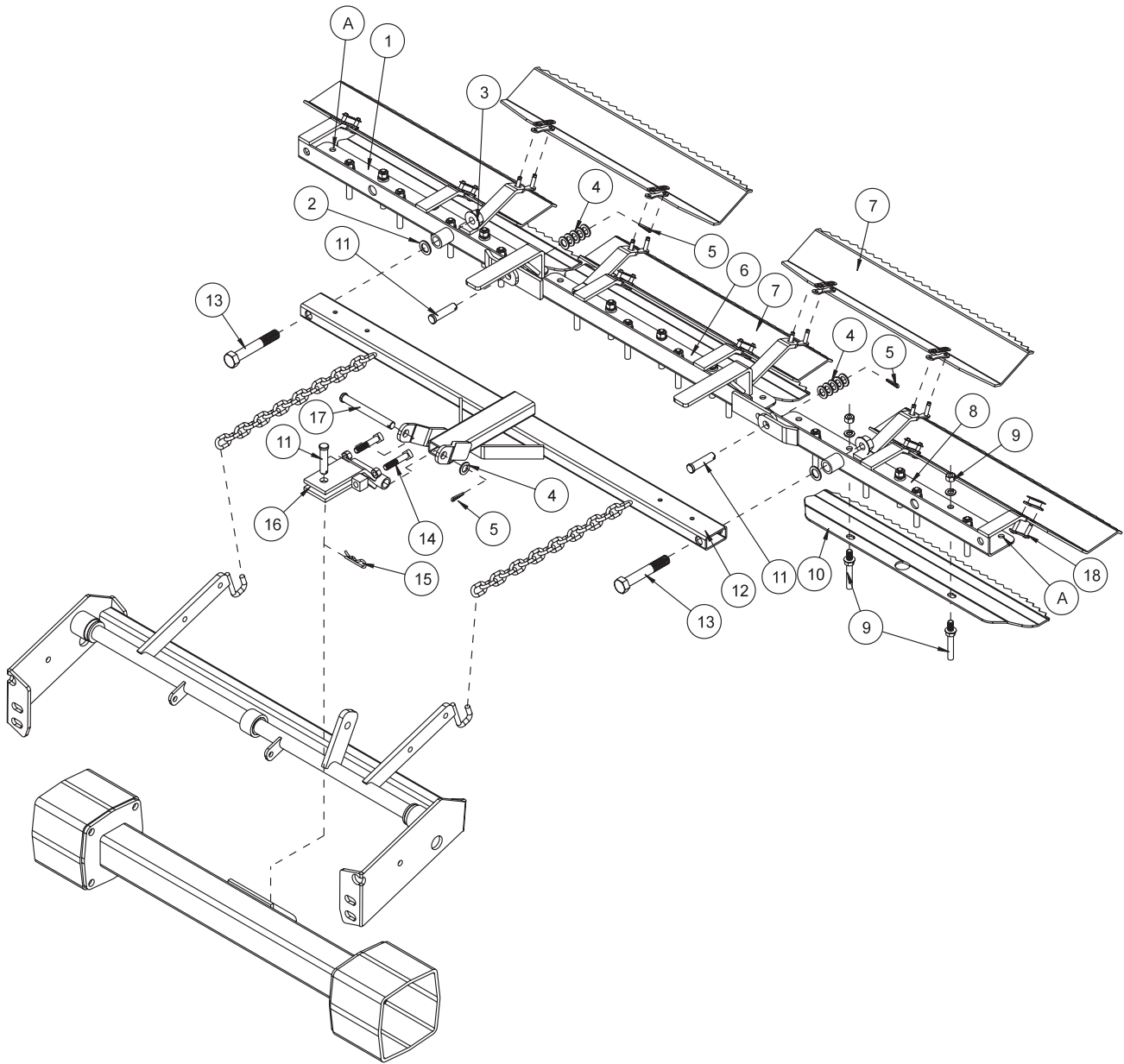

Accessories

13-438 RAKE ASSEMBLY WITH FINISHING BLADES PARTS LIST

REF#	PART#	DESCRIPTION	QUANTITY
1	13-441	Right Rake	1
2	HMB-58-14	Machine Bushing $\frac{5}{8}$ x 14GA	2
3	HNCL-58-11	Lock Nut $\frac{5}{8}$ - 11	2
4	HMB-12-14	Machine Bushing $\frac{1}{2}$ x 14GA	11
5	HP-18-100	Cotter Pin $\frac{1}{8}$ x 1	3
6	13-440	Center Rake	1
7	13-443	Finishing Blade	5
8	13-439	Left Rake	1
9*		Rake teeth	25
10	13-442	Groomer Blade	3
11	HCP-12-150	Clevis Pin $\frac{1}{2}$ - $1\frac{1}{2}$	3
12	13-365	Drawbar	1
13	HB-58-11-400	Bolt $\frac{5}{8}$ - 11 x 4	2
14	HSSQS-38-16-200	Stainless Steel Square Head Set Screw $\frac{3}{8}$ -16 x 2	2
	HN-38-16	Nut $\frac{3}{8}$ - 16	2
15	HHP-18	Bridge Pin $\frac{1}{8}$	1
16	13-647	Hitch (includes Ref 14)	1
17	HCP-12-450	Clevis Pin $\frac{1}{2}$ - $4\frac{1}{2}$	1
18	13-417	Connector Link	10
*	13-090	Rake Teeth Kit (Studs and Hardware)	1

INSTALLATION INSTRUCTIONS

- Attach drawbar (Ref 12) to hitch (Ref 16) using clevis pin, machine bushing and cotter pin (Ref 17, 4 and 5).
- Bolt rake teeth (Ref 9) to frames, keeping all the same length. Leave the two outside holes on right and left rake open (Ref A).
- Lay out rake frames (Ref 1,6 and 8). Connect them using clevis pin, machine bushing and cotter pin (Ref 11, 4 and 5).
- Attach drawbar to left and right frames using bolt, machine bushing, and nut (Ref 13, 2 and 3).
- Attach five finishing blades (Ref 7) to the tabs of the rake frames using master link (Ref 18). Blades may be mounted with saw tooth up or down, depending on the desired finish of the sand trap.
- Attach the rake hitch (Ref 16) to trap rake hitch on the rear axle using a clevis pin and bridge pin (Ref 11 and 15).
- The end links of chain on the drawbar are to be hooked to the hooks of the trap rake lift.
- With the rake on the ground pull the rake to the right side until it is 2-3 inches from the tire.
- Using the adjustment screw (Ref 14) on the right, adjust the screw until it hits the trap rake hitch, located on rear axle. Lock jam nut so adjustment will not change.
- Repeat steps 8 and 9 on left side.
- Turn machine on and test for operation of rake assembly by raising and lowering the rake assembly. Also with rake down, turn sharp corners to check that rake does not touch wheels.
- NOTE:** Test rake in sand to assure tire tracks are covered by the rake when turning sharp corners in either direction. If there are tire tracks, readjust using the adjusting screws on the hitch, so the rake comes closer to the tire.

GROOMER BLADES - GOLF COURSE USE ONLY.

- Place the three groomer blades (Ref 10) under the three rake assemblies (Ref 1, 6 and 8).
- Center blades below rear most row of rake teeth. The blade is designed to miss the outside two "teeth" and fit around the center "tooth".
- Remove the two "teeth" that line up with slots of each groomer blade. Move blade up and into position and reattach "teeth". Blade thickness should be accounted for by shortening the "teeth" an equal length.

13-606 RAKE ASSEMBLY WITH LEXAN BLADES DRAWING

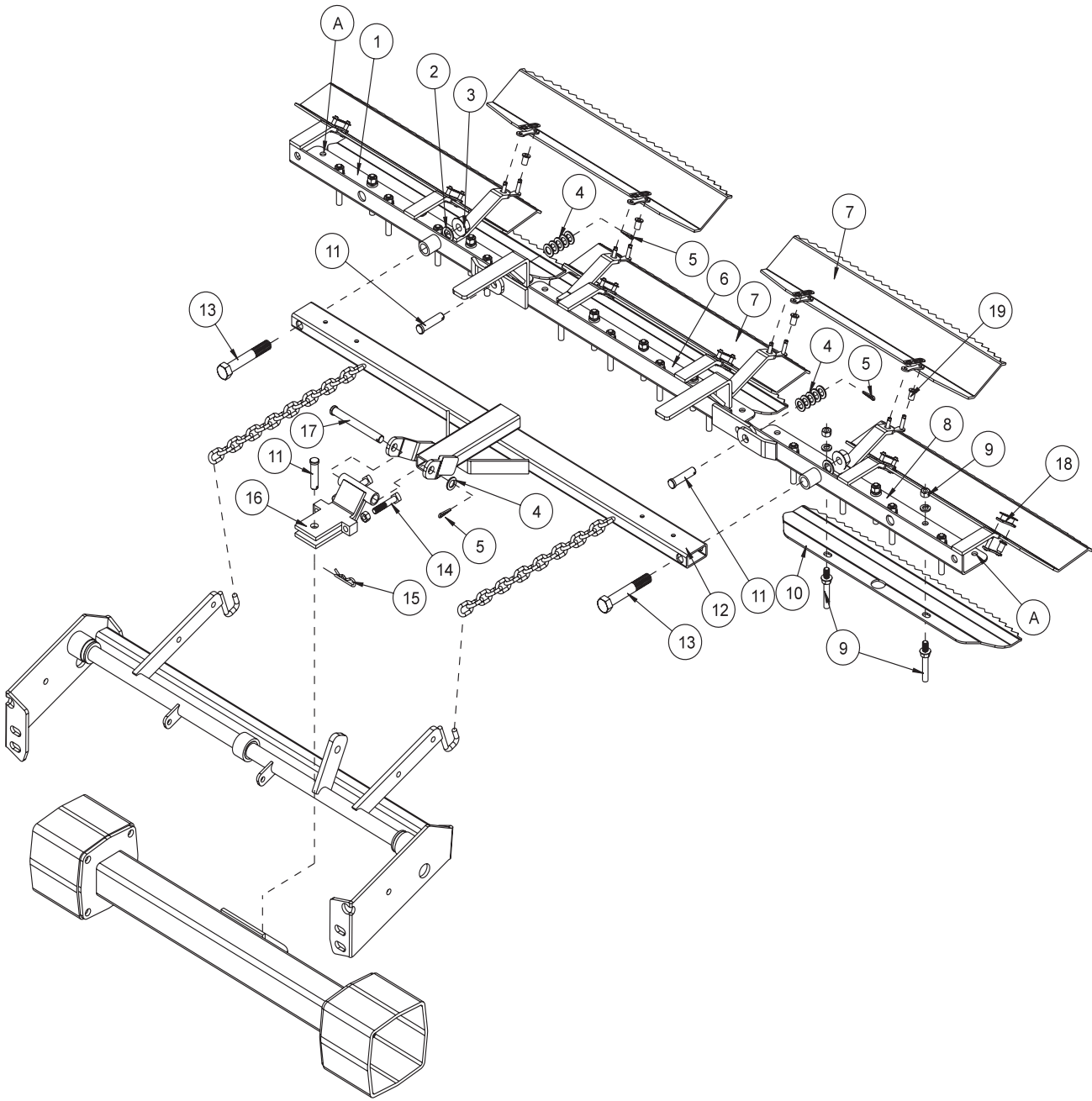

Accessories

13-606 RAKE ASSEMBLY WITH LEXAN BLADES PARTS LIST

REF#	PART#	DESCRIPTION	QUANTITY
1	13-441	Right Rake	1
2	HMB-58-14	Machine Bushing $\frac{5}{8}$ x 14GA	2
3	HNCL-58-11	Lock Nut $\frac{5}{8}$ - 11	2
4	HMB-12-14	Machine Bushing $\frac{1}{2}$ x 14GA	11
5	HP-18-100	Cotter Pin $\frac{1}{8}$ x 1	3
6	13-440	Center Rake	1
7	13-605	Lexan Blade (with weight & hardware)	5
8	13-439	Left Rake	1
9*		Rake teeth	25
10	13-442	Groomer Blade	3
11	HCP-12-150	Clevis Pin $\frac{1}{2}$ - 1 $\frac{1}{2}$	3
12	13-365	Drawbar	1
13	HB-58-11-400	Bolt $\frac{5}{8}$ - 11 x 4	2
14	HSSQS-38-16-200	Stainless Steel Square Head Set Screw $\frac{3}{8}$ -16 x 2	2
	HN-38-16	Nut $\frac{3}{8}$ - 16	2
15	HHP-18	Bridge Pin $\frac{1}{8}$	1
16	13-647	Hitch (includes Ref 14)	1
17	HCP-12-450	Clevis Pin $\frac{1}{2}$ - 4 $\frac{1}{2}$	1
18	13-417	Connector Link	10
19	18-272	Nylon Bushing	10
*	13-090	Rake Teeth Kit (Studs and Hardware)	1

INSTALLATION INSTRUCTIONS

1. Attach drawbar (Ref 12) to hitch (Ref 16) using clevis pin, machine bushing and cotter pin (Ref 17, 4 and 5).
 2. Bolt rake teeth (Ref 9) to frames, keeping all the same length. Leave the two outside holes on right and left rake open (Ref A).
 3. Lay out rake frames (Ref 1,6 and 8). Connect them using clevis pin, machine bushing and cotter pin (Ref 11, 4 and 5).
 4. Attach drawbar to left and right frames using bolt, machine bushing, and nut (Ref 13, 2 and 3).
 5. Attach five lexan blades (Ref 7) to the tabs of the rake frames using master link (Ref 18) and nylon bushings (Ref 19). Blades may be mounted with saw tooth up or down, depending on the desired finish of the sand trap.
 6. Attach the rake hitch (Ref 16) to trap rake hitch on the rear axle using a clevis pin and bridge pin (Ref 11 and 15).
 7. The end links of chain on the drawbar are to be hooked to the hooks of the trap rake lift.
 8. With the rake on the ground pull the rake to the right side until it is 2-3 inches from the tire.
 9. Using the adjustment screw (Ref 14) on the right, adjust the screw until it hits the trap rake hitch, located on rear axle. Lock jam nut so adjustment will not change.
 10. Repeat steps 8 and 9 on left side.
 11. Turn machine on and test for operation of rake assembly by raising and lowering the rake assembly. Also with rake down, turn sharp corners to check that rake does not touch wheels.
 12. **NOTE:** Test rake in sand to assure tire tracks are covered by the rake when turning sharp corners in either direction. If there are tire tracks, readjust using the adjusting screws on the hitch, so the rake comes closer to the tire.
- GROOMER BLADES - GOLF COURSE USE ONLY.
1. Place the three groomer blades (Ref 10) under the three rake assemblies (Ref 1, 6 and 8) .
 2. Center blades below rear most row of rake teeth. The blade is designed to miss the outside two "teeth" and fit around the center "tooth".
 3. Remove the two "teeth" that line up with slots of each groomer blade. Move blade up and into position and reattach "teeth". Blade thickness should be accounted for by shortening the "teeth" an equal length.

13-684 SANDRAKE BRUSH KIT DRAWING

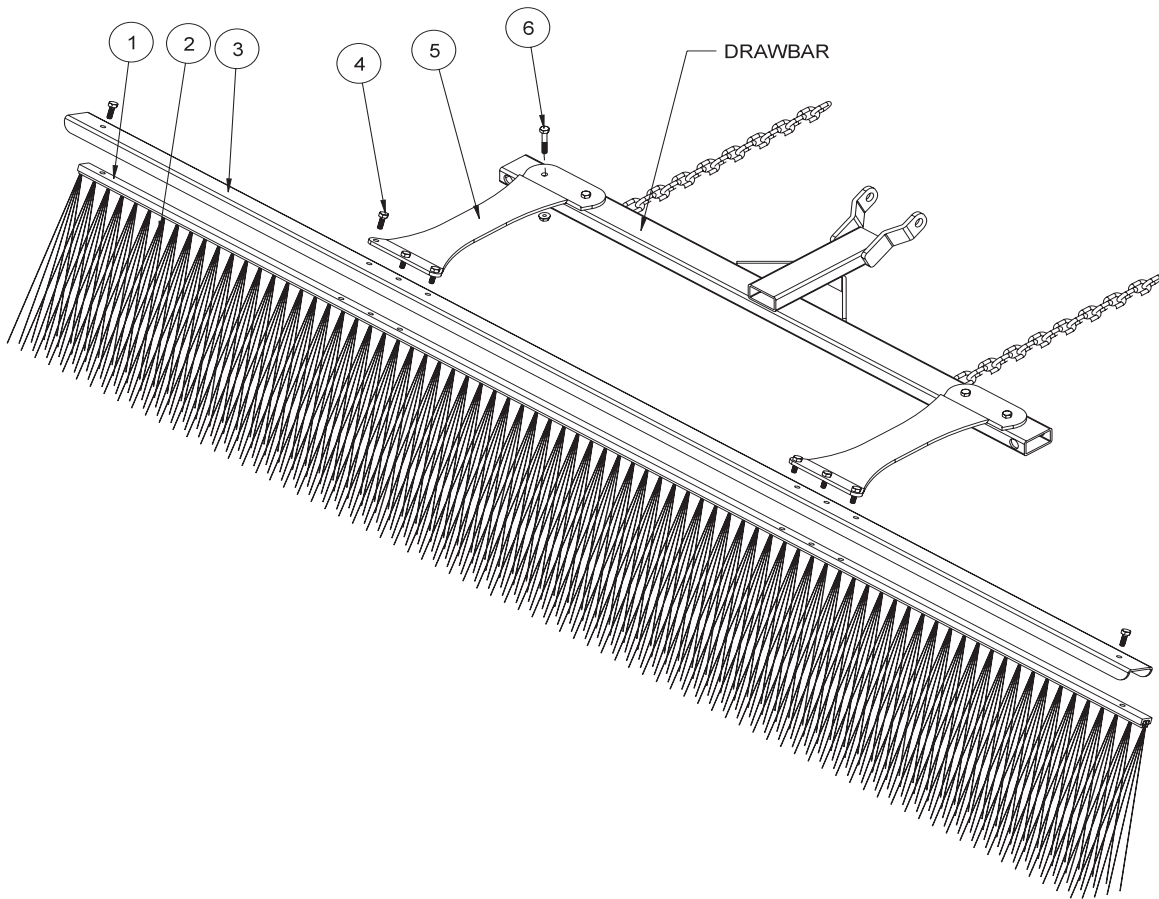

HOLE LOCATION

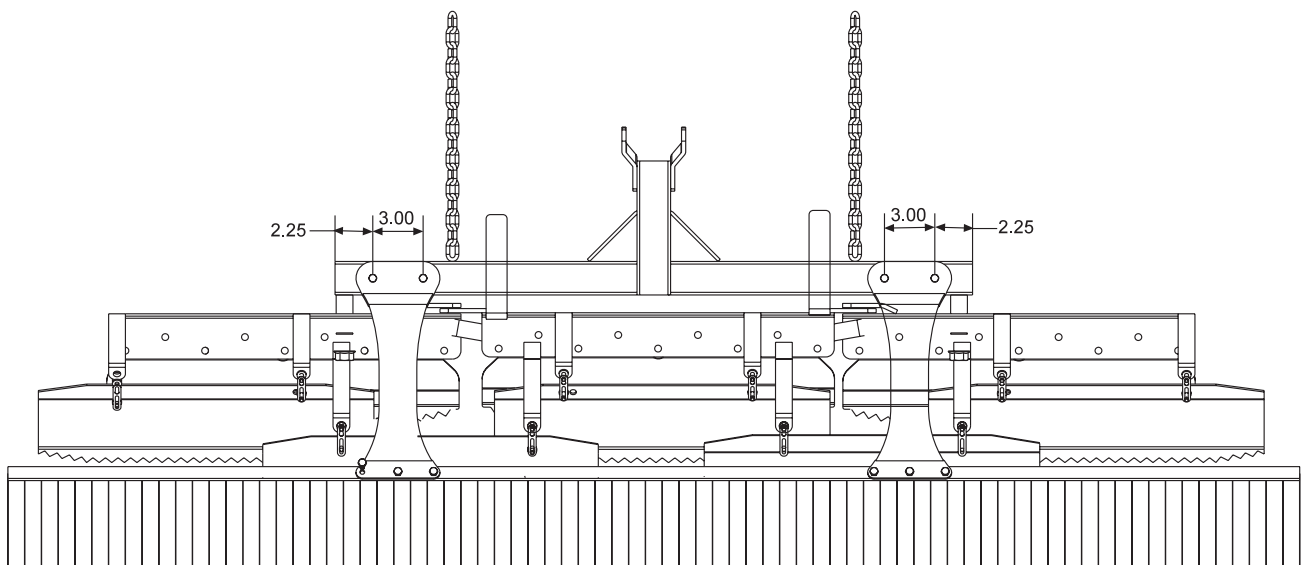

13-684 SAND RAKE BRUSH KIT PARTS LIST

REF#	PART#	DESCRIPTION	QUANTITY
1	13-683	Brush Track	1
2	13-682	Brush 77 x 11	1
3	13-688	Brush Channel	1
4	HB-14-20-075	Bolt $\frac{1}{4}$ - 20 x $\frac{3}{4}$	8
	HNFL-14-20	Flange Whiz-Lock Nut $\frac{1}{4}$ - 20	8
5	13-681	Mounting Brackets	2
6	HB-14-20-150	Bolt $\frac{1}{4}$ - 20 x $1\frac{1}{2}$	4
	HNFL-14-20	Flange Whiz-Lock Nuts $\frac{1}{4}$ - 20	4

INSTALLATION INSTRUCTIONS

To be used with 13-438 and 13-606 Rakes.

1. Place the brush (Ref 2) into the brush track (Ref 1). Place the brush channel (Ref 3) between the brush track and the mounting brackets. Now bolt the mounting brackets (Ref 5) to the brush track using the $\frac{3}{4}$ " bolts and flange whiz-lock nuts (Ref 3).
2. Two holes need to be drilled into the drawbar of the rake to install the brush. Drill two .281 holes $2\frac{1}{4}$ " in from each end and 3" apart (see drawing).
3. Mount the brush assembly to the drawbar using four $\frac{3}{4}$ " bolts and flange whiz-lock nuts (Ref 5).

13-298 FAN RAKE ATTACHMENT DRAWING

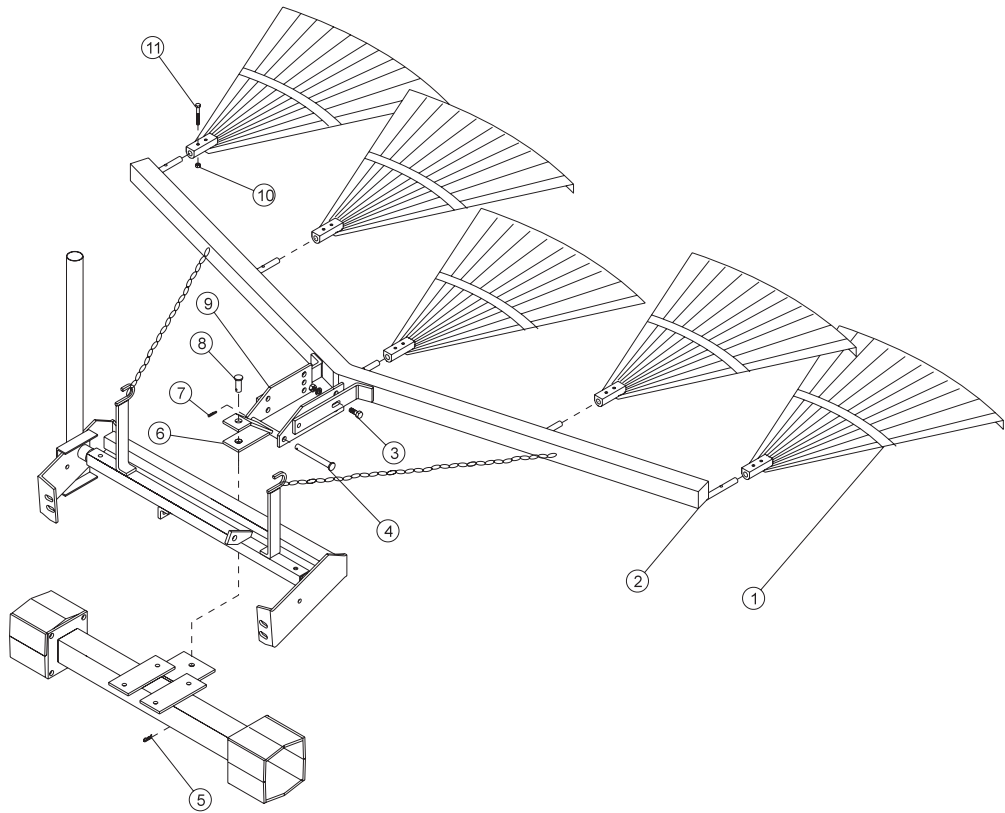

13-319 FAN RAKE KIT

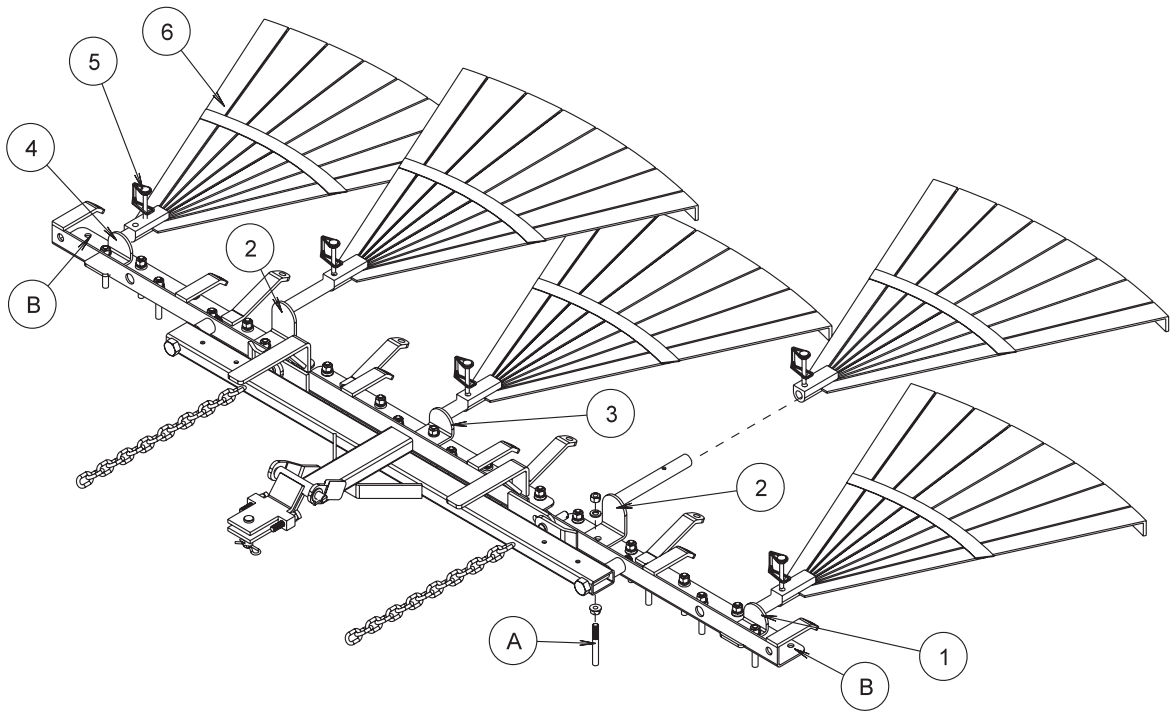

Accessories

13-298 FAN RAKE ATTACHMENT PARTS LIST

REF#	PART#	DESCRIPTION	QUANTITY
1	13-310	Rake	5
2	13-306	Frame	1
3	HB-38-16-100	Bolt $\frac{3}{8}$ - 16 x 1	4
	HN-38-16	Nut $\frac{3}{8}$ - 16	4
	HWL-38	Lockwasher $\frac{3}{8}$	4
4	HCP-12-450	Clevis Pin $\frac{1}{2}$ x $4\frac{1}{2}$	1
5	HHP-18	Bridge Pin $\frac{1}{8}$	1
6	19-107	Drawbar	1
7	HP-18-100	Cotter Pin $\frac{1}{8}$ x 1	1
8	HCP-12-150	Clevis Pin $\frac{1}{2}$ x $1\frac{1}{2}$	1
9	13-307	Hitch	2
10	HNCL-14-20	Center Lock Nut $\frac{1}{4}$ - 20	5
11	HB-14-20-200	Bolt $\frac{1}{4}$ - 20 x 2	5

INSTALLATION INSTRUCTIONS

1. Remove the complete rake assembly from the trap rake. Replace the clevis pin and bridge pin in the hitch for future use with the rake.
2. Assemble hitch (Ref 9) to frame (Ref 2) using hardware (Ref 3). Assemble drawbar (Ref 6) to the hitch using clevis pin (Ref 4) and cotter pin (Ref 7), as shown. The different holes in the hitch are for adjusting the angle of the rakes.
3. Assemble the five rakes (Ref 1) to the frame (Ref 2) using $\frac{1}{4}$ - 20 x 2 bolt and center lock nuts (Ref 10 and 11). Slide the fan rake assembly under the rear of the trap rake to the hitch. Attach the drawbar (Ref 6) to the hitch using the clevis pin (Ref 8) and the bridge pin (Ref 5).
4. Hook the chains from the frame to the hooks on the rake lift.

13-319 FAN RAKE KIT PARTS LIST

REF#	PART#	DESCRIPTION	QUANTITY
1	13-326	Left Holder	1
2	13-329	Long Holder	2
3	13-327	Center Holder	1
4	13-328	Right Holder	1
5	29-541	Lock Pin	5
6	13-310	Rake	5

FAN RAKE KIT INSTRUCTIONS

1. Remove connector links that hold rake blades to rake frame if desired.
2. Remove groomer blades from rake frame that are held on with rake teeth studs (Ref A). Replace rake teeth studs, if desired.
3. Place left holder (Ref 1), angle side up, to the second rake tooth hole from the end and install rake tooth stud. The first rake tooth hole from each end (Ref B) have no rake teeth in them.
4. Remove the 8th rake tooth stud from the end of right and left rake frame and place long holders (Ref 2) on top, reinstall rake teeth studs.
5. Remove rake tooth in direct center of rake and install the center holder (Ref 3). Reinstall rake teeth studs.
6. Place right holder (Ref 4), angle side up, to the second rake tooth hole from the end and install rake tooth stud. The first rake tooth hole from each end (Ref B) have no rake teeth in them.
7. Slide fan rake (Ref 6) onto holders and pin with lock pin (Ref 5).



26-007 PROFESSIONAL INFIELD FINISHER DRAWING

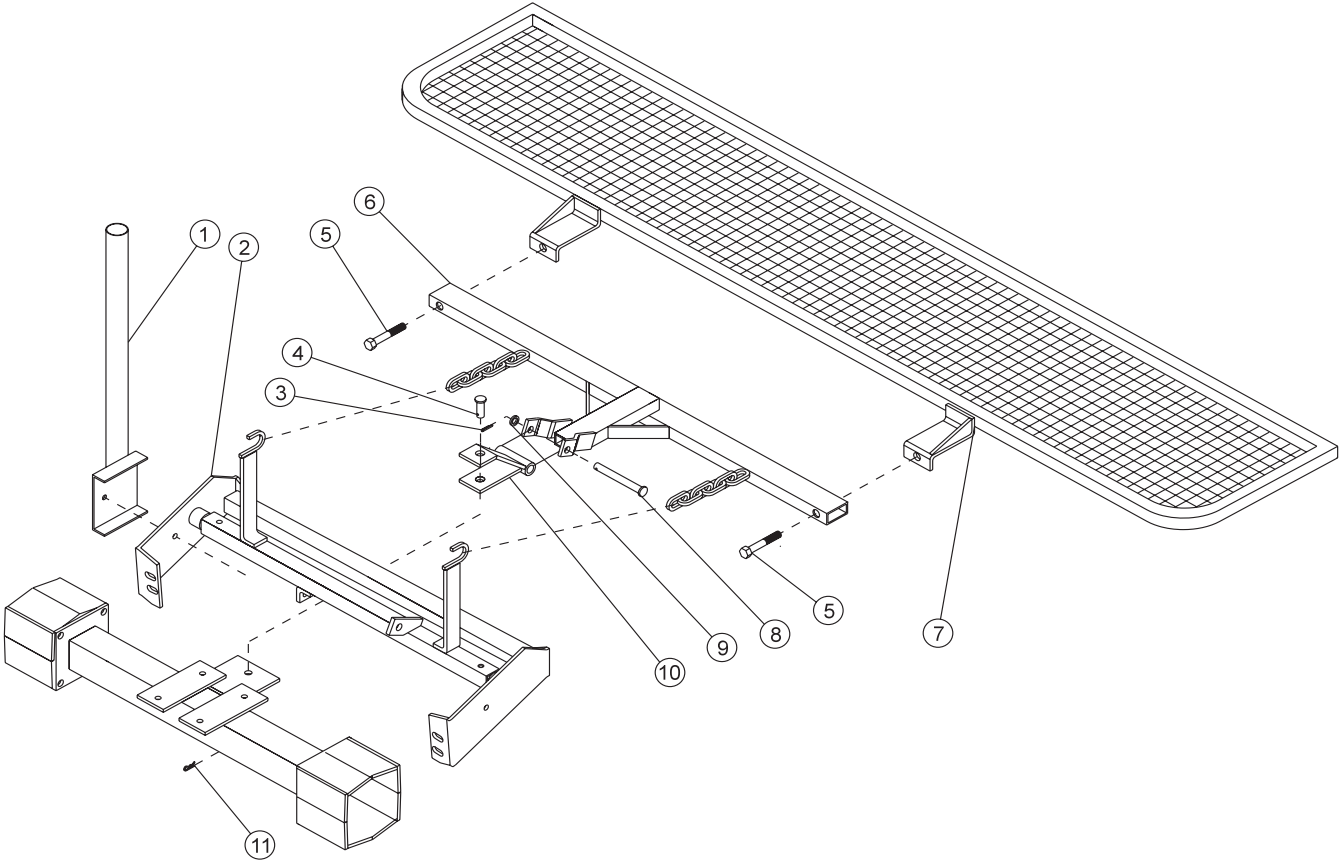

Accessories

26-007 PROFESSIONAL INFIELD FINISHER PARTS LIST

REF#	PART#	DESCRIPTION	QUANTITY
1		Rake Holder (Part of Trap Rake)	1
2		Rake Lift (Part of Trap Rake)	1
3	HP-18-100	Cotter Pin $\frac{1}{8}$ x 1	1
4	HCP-12-150	Clevis Pin $\frac{1}{2}$ x $1\frac{1}{2}$	1
5	HB-58-11-300	Bolt $\frac{5}{8}$ - 11 x 3	2
	HNCL-58-11	Center Lock Nut $\frac{5}{8}$ - 11	2
6	13-365	Drawbar	1
7	26-045	Leveling Screen	1
8	HCP-12-450	Clevis Pin $\frac{1}{2}$ x $4\frac{1}{2}$	1
9	HMB-12-14	Machine Bushing $\frac{1}{2}$ x 14GA	1
10	19-107	Hitch	1
11	HHP-18	Bridge Pin $\frac{1}{8}$	1

INSTALLATION INSTRUCTIONS

The Professional Field Finisher is used for smoothing and leveling fields to professional standards.

1. Attach leveling screen (Ref 7) to drawbar (Ref 6) using two bolts and center lock nuts (Ref 5).
2. Attach hitch (Ref 10) to drawbar (Ref 6) using $\frac{1}{2}$ x $4\frac{1}{2}$ clevis pin (Ref 8), $\frac{1}{2}$ x 14GA machine bushing (Ref 9) and a $\frac{1}{8}$ x 1 cotter pin (Ref 3).
3. Mount Professional Field Finisher to the hitch on the trap rake with a $\frac{1}{2}$ x $1\frac{1}{2}$ clevis pin (Ref 4) and $\frac{1}{8}$ " bridge pin (Ref 11).
4. Hook chains from finisher to rake lift arms.
5. **NOTE:** When assembled properly, rake will angle down from front to back. If front of finisher is not higher than the back, damage will result to infield.

26-008 FLEX ACTION FIELD FINISHER DRAWING

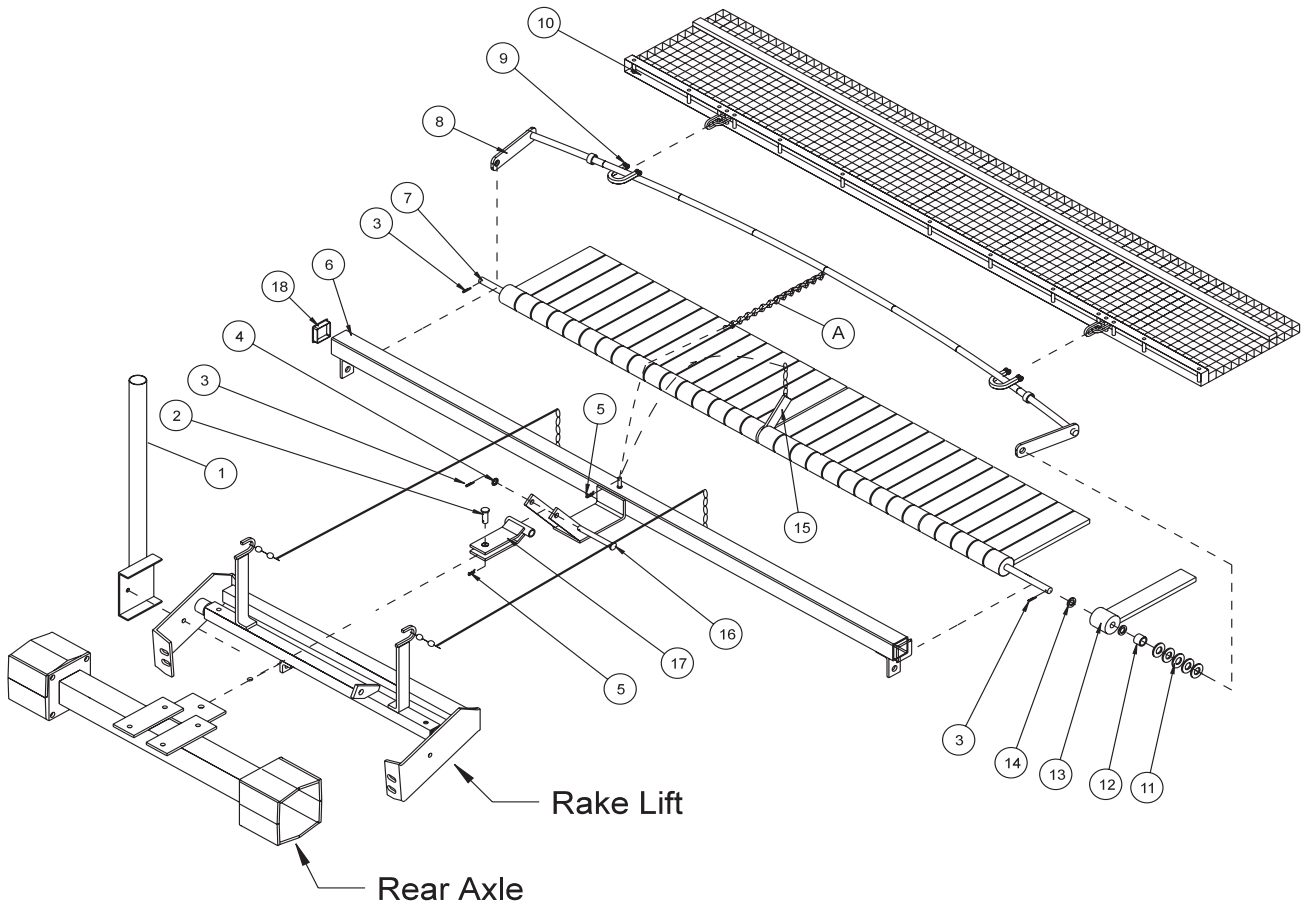

Accessories

26-008 FLEX ACTION FIELD FINISHER PARTS LIST

REF#	PART#	DESCRIPTION	QUANTITY
1		Rake Lift	1
2	HCP-12-150	Clevis Pin $1\frac{1}{2}$ x $1\frac{1}{2}$	1
3	HP-18-100	Cotter Pin $1\frac{1}{8}$ x 1	3
4	HMB-12-14	Machine Bushing $1\frac{1}{2}$ - 14GA	1
5	HHP-18	Bridge Pin $1\frac{1}{8}$	2
6	26-046	Frame	1
7	26-049	Mounting Bar	1
8	26-047	Leveler Bar	1
9	21-060	$\frac{3}{8}$ Chain Clevis	2
10	26-115	Mesh Finisher	1
11	HMB-58-14	Machine Bushing $\frac{5}{8}$ x 14GA	10
12	11-040	Spacer $\frac{3}{4}$ "	2
13	26-041	Rasp Flail	32
14	HW-58	Washer $\frac{5}{8}$	32
15	26-048	Flail Bar Strap	1
16	HCP-12-450	Clevis $1\frac{1}{2}$ x $4\frac{1}{2}$	1
17	19-107	Hitch	1
18	18-297	Cap Plug	2
19	HB-38-16-125	Bolt $\frac{3}{8}$ - 16 x $1\frac{1}{4}$	4
	HN-38-16	Nut $\frac{3}{8}$ - 16	4
20	26-116	Right Extension Arm	1
	26-117	Left Extension Arm	1

26-008 FLEXACTION FIELD FINISHER DRAWING

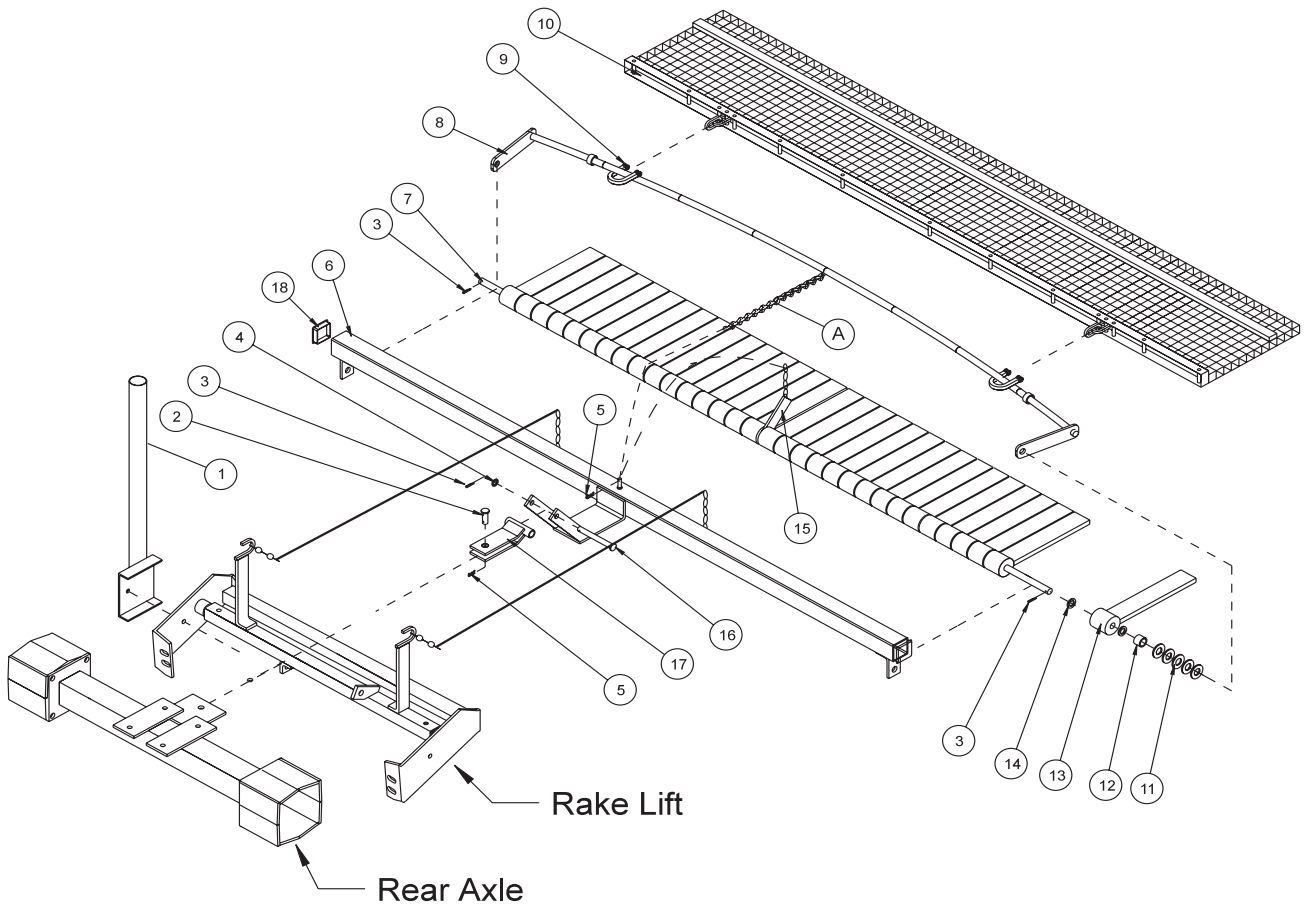

Accessories

INSTALLATION INSTRUCTIONS

1. Install flail bar strap (Ref 15) to center of mounting bar (Ref 7) with chain on top of flail bar strap and mounting bar bent away from you. Apply a light coat of lubricant to overall length of mounting bar.
2. Install one rasp flail (Ref 13) with knobby side down adjacent to sides of flail bar strap (Ref 15). Now install a flat washer (Ref 14) so it sits adjacent with the outside of the rasp flail. Continue to install flails with knobby sides down with Washers between until you have 16 flails and washers on each side of bar strap. Force all flails tightly toward bar strap.
3. After all 32 flails have been installed, place one spacer (Ref 12) to each end of mounting bar adjacent to washer.
4. Install leveler bar (Ref 8) to mounting bar, with curved leveler bar resting on top on the smooth sides of flails. If all flails and washers do not fit snugly at this time, remove leveler bar and install enough machine bushings to ensure a snug fit. Then reinstall leveler bar.
5. Lay the frame (Ref 6) on the floor or bench with weld tabs facing up. Install ends of assembled mounting bar, with knobby sides of flails up, into welded tabs on each end of frame and secure with cotter pin (Ref 3).
6. Install flail bar strap (Ref 15) to center tab on frame with $\frac{3}{8}$ -16 x 1 bolt and $\frac{3}{8}$ -16 center lock nut. Loose fit is required. No not over tighten
7. Flip assembly over so knobby sides of flails are now facing down. Install hitch (Ref# 17) to frame with clevis pin (Ref 16) and cotter pin (Ref 3). The hitch should be attached to the frame as shown.
8. Install bar strap chain over welded pin on frame. Install leveler bar chain on to pin and secure in place with bridge pin. Use last bridge pin and clevis pin to hitch field finisher to your machine.
9. Add extension arms (Ref 20) to rake lift. Use the center hole and only (2) $1\frac{1}{4}$ bolts (Ref 19). Hook lift chains to extension arms (Ref 20).

OPERATING INSTRUCTIONS

Running attachment with all flails down, flat on the surface, will provide a leveling function. Running attachment partially raised and flails at a 20° - 40° angle in relation to the level surface, will provide a finishing function. The flails increase down pressure for desired finish. Drive in wide circular patterns and increase or decrease ground speed to achieve desired finish.

MESH FINISHER

To get a smoother finish, Install a Mesh Finisher onto your Flex Action Field Finisher.

1. If the 26-008 Flex Action Field Finisher is on your machine, lower it to the ground. You may have to pull machine ahead slightly so the Field Finisher is lying flat on the ground or floor.
2. Lay mesh finisher behind field finisher with weight bar facing up and chain hooks towards field finisher.
3. Take the two chain clevis' and hook onto leveler bar and then thorough the chain hooks on mesh finisher. The clevis pin that comes with the chain clevis should go through the chain clevis, first link on chain hook (on the mesh finisher) and then through other side of the chain clevis. Insert the cotter pin.
4. Center Mesh Finisher with Flex Action Field Finisher.
5. Raise lift on your machine to insure proper ground clearance before driving your machine.
6. Chain length (Ref A) is to control amount of mesh trailing behind flails for wet or dry conditions. For wet conditions: Shorten chains (Ref A). For dry conditions: May use maximum amount of chain (Ref A) to make desired finish.

34-191 BOX GRADER DRAWING

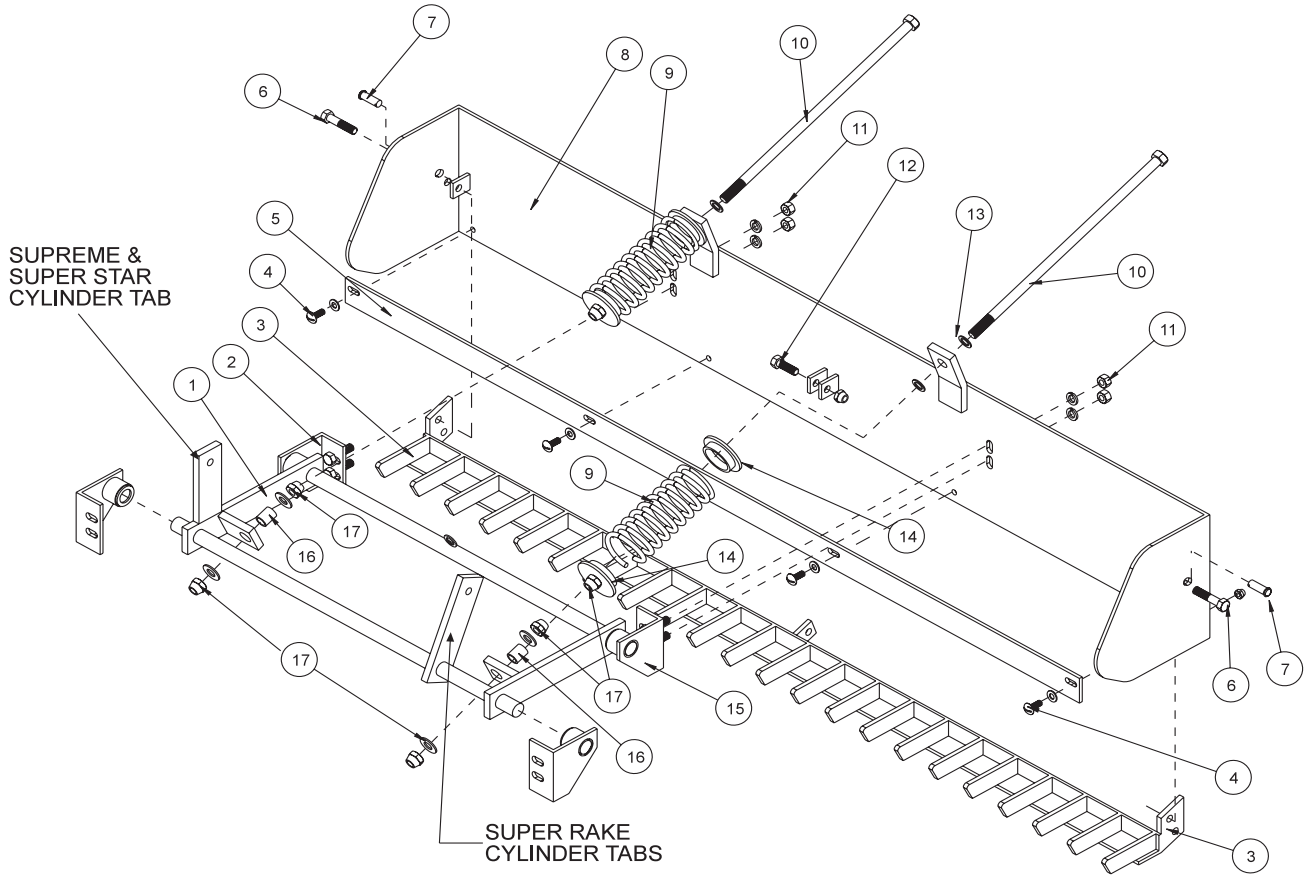

Accessories

34-191 BOX GRADER PARTS LIST

REF#	PART#	DESCRIPTION	QUANTITY
1	34-221	Lift Assembly	1
2	34-220	Right Pivot Bracket	2
3	34-217	Break Up Bar	1
4	HST-38-16-100	Truss Head Machine Screw $\frac{3}{8}$ - 16 x 1	4
	HW-38	Washer $\frac{3}{8}$	4
	HNCL-38-16	Center Lock Nut $\frac{3}{8}$ - 16	4
5	34-218	Cutter Blade	1
6	HB-12-13-250	Bolt $\frac{1}{2}$ - 13 x 2 $\frac{1}{2}$	2
	HNCL-12-13	Center Lock Nut $\frac{1}{2}$ - 13	2
7	HCP-12-150	Clevis Pin $\frac{1}{2}$ x 1 $\frac{1}{2}$	2
	HHP-18	Bridge Pin $\frac{1}{8}$	2
8	34-216	Blade Assembly	1
9	13-276	Compression Spring	2
10	34-214	Spring Rod	2
11	HB-12-13-125	Bolt $\frac{1}{2}$ - 13 x 1 $\frac{1}{4}$	4
	HW-12	Washer $\frac{1}{2}$	4
	HWL-12	Lockwasher $\frac{1}{2}$	4
	HN-12-13	Nut $\frac{1}{2}$ -13	4
12	HB-12-13-150	Bolt $\frac{1}{2}$ - 13 x 1 $\frac{1}{2}$	1
	HNCL-12-13	Center Lock Nut $\frac{1}{2}$ - 13	1
13	HMB-58-14	Machine Bushing $\frac{5}{8}$ - 14GA	4
14	13-277	Spring Pad	4
15	34-219	Left Pivot Bracket	2
16	34-215	Spacer	2
17	HNCL-58-11	Center Lock Nut $\frac{5}{8}$ - 11	4
	HW-58	Washer $\frac{5}{8}$	2

BOX GRADER LIFT ASSEMBLY

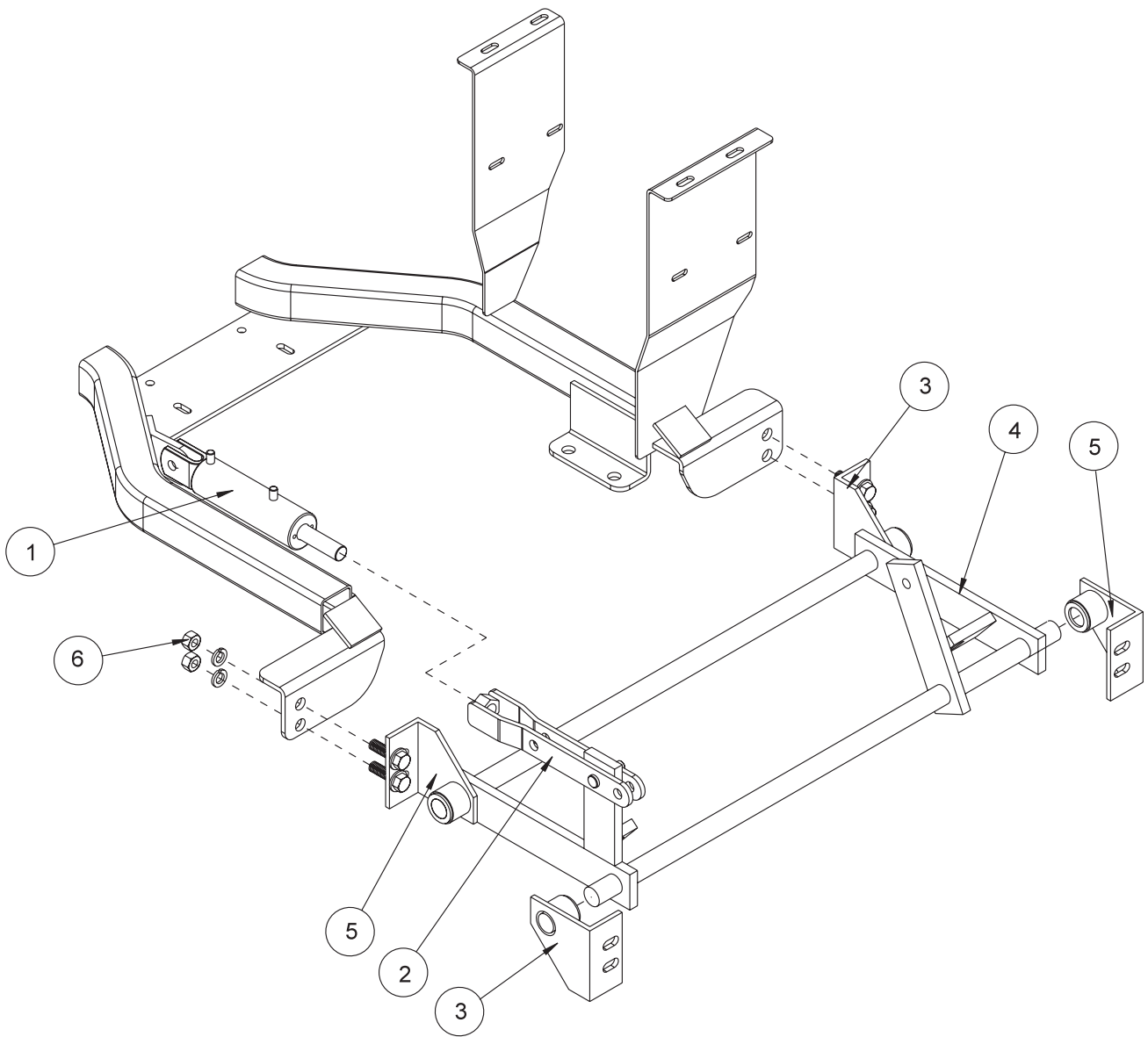

Accessories

BOX GRADER PARTS LIST

REF#	PART#	DESCRIPTION	QUANTITY
1	13-357	Hydraulic Cylinder (comes with machine)	1
	HNJ-34-16	Jam Nut $\frac{3}{4}$ - 16	1
2	13-366	Cylinder Extension (comes with machine)	1
3	34-219	Left Pivot Assembly	2
4	34-221	Lift Assembly	1
5	34-220	Right Pivot Bracket	2
6	HB-12-13-150	Bolt $\frac{1}{2}$ - 13 x $1\frac{1}{2}$ (comes with machine)	4
	HW-12	Washer $\frac{1}{2}$	4
	HWL-12	Lockwasher $\frac{1}{2}$	4
	HN-12-13	Nut $\frac{1}{2}$ - 13	4

INSTALLATION INSTRUCTIONS

1. To mount Box Grader to Super Rake you must remove the rake lift.
2. On all Super Rakes unhook the speed boss arm before removing the rake lift. Completely remove the rod speed limiter and ball joint from machine. The speed boss does not need to function when using the Box Grader.
3. Position the Box Grader unit at the rear of the trap rake, using the bolts (Ref 6) that held the rake lift on, bolt pivot brackets (Ref 3 & 5) to the frame. **Please note** the way the pivot brackets mount to the machine. Trim cuts point up and tabs bend out.
4. Loosen jam nut on cylinder and turn the cylinder extension (Ref 2) within a $\frac{1}{4}$ " of the end of the cylinder shaft.
5. Attach the cylinder extension to the Box Grader using the second hole from the end.
6. Turn the trap rake on and test the operation of the cylinder lift several times to make sure the grader blade travels all the way up. To adjust, turn cylinder extension counterclockwise to lower and clockwise to raise.
7. Springs should be adjusted to a length of 7". Adjust tension to your preference. Tighten to increase trip pressure.
8. To lower break up bar, remove the two clevis pins from the sides of the Box Grader. The break up bar will tilt forward.

The speed boss is not used with Box Grader. Leave unhooked.

NOTE:

42-582 GREEN STAR SPIKER REEL SET (3) DRAWING

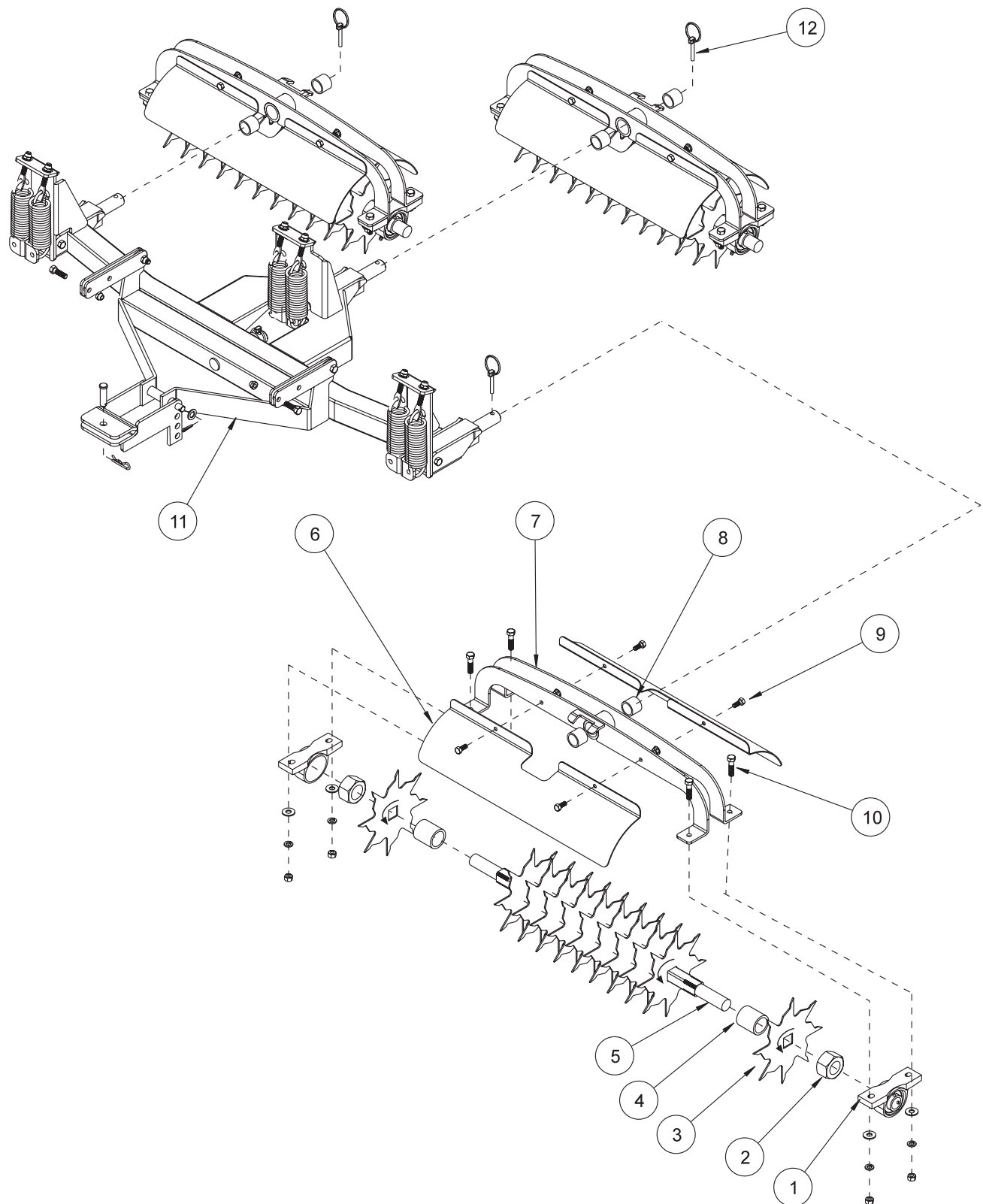

Accessories

42-582 GREEN STAR SPIKER REEL SET (3) DRAWING

REF#	PART#	DESCRIPTION	QUANTITY
1	11-094	Pillow Block	6
2	HNJ-114-12	Jam Nut 1 ¹ / ₄ - 12	6
3	42-583	Spiker Blade	33
4	8965-1.875	Spiker Blade Spacer (1.875")	30
5	42-554	Spiker Shaft	3
6	42-578	Spiker Cover	6
7	42-574	Fork	3
8	18-295	Oilite Bushing (part of 42-574)	6
9	HB-516-18-075	Bolt ⁵ / ₁₆ - 18 x ³ / ₄	12
	HNTL-516-18	Lock Nut ⁵ / ₁₆ - 18	12
10	HB-38-16-150	Bolt ³ / ₈ - 16 x 1 ¹ / ₂	12
	HWL-38	Lock Washer ³ / ₈	12
	HW-38	Washer ³ / ₈	12
	HN-38-16	Nut ³ / ₈ - 16	12
11	42-586	Green Star RBS Main Frame	1
12	42-539	Lynch Pin ⁵ / ₁₆ (part of main frame)	3

ADJUSTMENTS AND OPERATION INSTRUCTIONS

ADJUSTMENT

The springs are preset for maximum down pressure, and should not need to be adjusted. If you feel the need to adjust the springs please call for further instructions. The unit comes pre-adjusted for most models. When installing spiker system use lower mounting holes on hitch.

Tire pressure should be 4 psi in the front and 7 psi in the rear tire for best traction.

OPERATION

Make sure the spiker system has been installed and adjusted properly for your model of bunker rake. Always transport in fully raised position. Always remove flag pole before spiking green. Do not stop on green while spiking. Do not spike up steep slopes or loss of traction may result. Do not turn while spiking.

To begin spiking, lower unit all the way down as you come across collar and continue straight across green until reaching other collar and raise as you come off of green. Overlap stripes the same as if you were mowing.

INSTALLATION

Spiker blades must be installed so that the jagged side of the tooth cuts into the turf first. This allows only a piercing of the turf, whereas if the straight edge of the spiker blades enters first it will act more as a cutting effect.

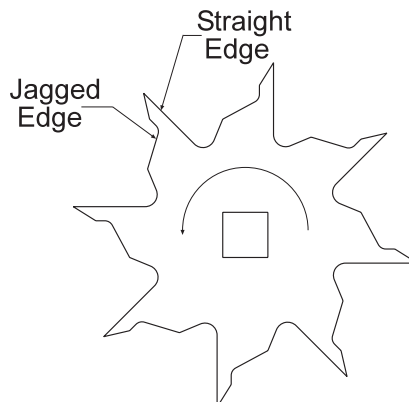

42-586 RBS MAIN FRAME DRAWING

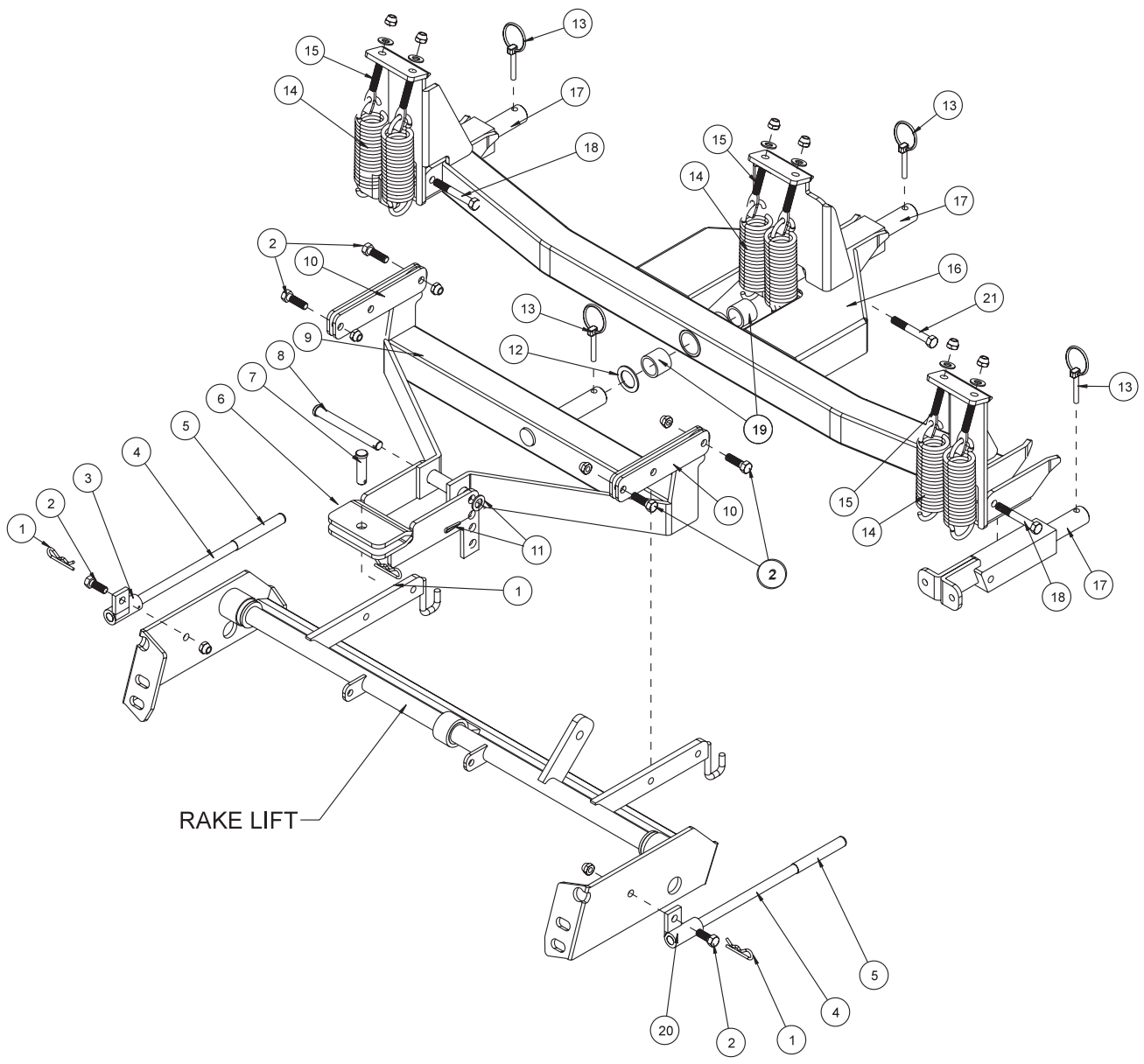

Accessories

42-586 RBS MAINFRAME PARTSLIST

REF#	PART#	DESCRIPTION	QUANTITY
1	HHP-18	Bridge Pin $\frac{1}{8}$	3
2	HB-38-16-125	Bolt $\frac{3}{8}$ - 16 x $1\frac{1}{4}$	6
	HNTL-38-16	Lock Nut $\frac{3}{8}$ - 16	6
3	42-525	Right Rod Holder	1
4	42-580	Stabilizer Rods	2
5	13-499	Grip	2
6	42-565	Hitch	1
7	HCP-12-175	Clevis Pin $\frac{1}{2}$ - $1\frac{3}{4}$	1
8	HCP-12-450	Clevis Pin $\frac{1}{2}$ - $4\frac{1}{2}$	1
9	42-575	Three Point Hitch	1
10	42-566	Lift Strap	4
11	HMB-12-14	Machine Bushing $\frac{1}{2}$ x 14GA	1
	HP-18-100	Cotter Pin $\frac{1}{8}$ x 1	1
12	HMB-100-14	Machine Bushing 1 x 14GA	1
13	42-539	Lynch Pin $\frac{5}{16}$	4
14	42-536	Spring	6
15	42-537	Spade Bolt	6
	HNTL-38-16	Lock Nut $\frac{3}{8}$ - 16	6
16	42-577	Frame	1
17	42-576	Spring Tower	3
18	HB-38-16-275	Bolt $\frac{3}{8}$ - 16 x $2\frac{3}{4}$	2
	HNTL-38-16	Lock Nut $\frac{3}{8}$ - 16	2
19	18-295	Oilite Bushing (part of 42-577)	2
20	42-524	Left Rod Holder	1
21	HB-38-16-250	Bolt $\frac{3}{8}$ - 16 x $2\frac{1}{2}$	1
	HNCL-38-16	Center Lock Nut $\frac{3}{8}$ - 16	1

This is a list of decals located on the Super Rake. Part number, description and location will help in reordering decals.

13-437	Front Wheel Drive	Lower Right Fender
13-556	Safety Warning	Console
13-598	"2"	Right and Left Outside Fender (13-551 only)
13-640	Instrument Panel	Right Fender
13-689	Super Rake	Right and Left Outside Fender
13-695	Valve Panel	Left Fender
16-088	Moving Parts Hot	Inside Rear Cowling
25-277	Alternator Battery	Above Battery On Nose Cone
25-279	Stay Clear	Rear Cowling
25-286	Pinch Points	Front Right and Left Fender - Rear Hydraulic Pump
25-298	Warning Hot	Rear Cowling
25-307	Refuel Gas	Left Fender Right Side Gas Cap
25-308	Caution Engine Idle	Engine
25-333	Briggs And Stratton	Visible From Operators Position
25-337	Speed Boss	Hang Tag
25-349	Foot Pedal	Foot Pedal
25-352	Bypass Valve	Hang Tag
25-354	Tire Pressure 5 psi	All Three Wheels
25-357	Smithco Black	Right and Left Nose Cone
25-361	Technical Assistance	Main Frame
27-077	Smithco Round	Steering Wheel
27-086	CE	Left Side of Rear Cowling Below Seat (overseas machines only)
27-087	Park Brake	Left Side Console
27-093	Hydraulic Fluid Level	Right Fender Behind Garbage Box
27-096	Plow Lift	Optional
33-245	10W40	Oil Tank Cap

QUICK REFERENCE REPLACEMENT PARTS

REPLACEMENT FILTERS

23-031	Hydraulic Oil Filter	
15-165-01	Air Filter Element with Pre-Cleaner	Briggs and Stratton# 5050
11-131	Air Filter Element Fender Mounted	
50-403	Fuel Filter	
13-531	Engine Oil Filter	Briggs and Stratton# 492932

SEAL KITS

13-110	Variable Pump	
14-098	Seal Kit	
13-032 and 13-615	Wheel Motors	
14-080	Seal Kit	
42-220	2-Bank Hydraulic Valve	
14-062	Seal Kit	
14-106	Relief Assembly Kit	
14-203	Spring Centering Assembly Kit (1 per bank)	
42-227	3-Bank Hydraulic Valve	
14-205	Seal Kit	
14-106	Relief Assembly Kit	
14-203	Spring Centered Assembly Kit (1 per bank)	
13-292	Hydraulic Cylinder (Attachment Lift Cylinder)	
13-357	Hydraulic Cylinder for Rake Lift	
13-406	Hydraulic Cylinder for Sand Plow Lift	
14-267	Seal Kit	

FLUIDS

Engine Oil	Refer to Engine Manual	
Hydraulic Fluid	SAE 10W-40 API Service SJ or higher Motor Oil	

OTHER PARTS

Spark Plugs	RC12YC (Gap 0.030 inch (0.76mm))
-------------	----------------------------------

LIMITED WARRANTY

SMITHCO warrants this product to be free from defects in material and workmanship under normal use for one year from the date of purchase by the original user. (60 days if product is used for rental purposes.) All warranty claims must be handled through a SMITHCO authorized dealer or by SMITHCO, INC. All transportation charges must be paid by the purchaser.

There is no further express warranty. All implied warranties, including those of merchantability and fitness for a particular purpose, are limited to one year, (60 days if product is used for rental purposes) from the date of purchase by the original user, and to the extent permitted by law any and all implied warranties are excluded and disclaimed after the expiration of such period.

All incidental and consequential damages, including pickup and delivery of the unit, communication, mileage charges and/or rental of a replacement unit during repair, are not covered under this warranty, nor is any loss of income and/or other loss resulting from the failure of the product to function due to a warranty defect.

The following items are not covered under the SMITHCO warranty, and are warranted by their respective manufacturer.

- (a) Engine and engine parts, including starters, generators, alternators and filters.
- (b) Transaxle, differentials, gear boxes and mechanical pumps.
- (c) Hydrostatic transmissions, hydraulic pumps and motors.
- (d) Batteries.
- (e) Wheels and tires.

A copy of the warranty for the above items is furnished if necessary with each SMITHCO product.

Some states do not allow limitations on how long an implied warranty lasts, or the exclusion or limitations of incidental or consequential damages, so the above limitations or exclusions may not apply to you. This warranty gives you specific legal rights and you may also have other rights, which may vary from state to state.

Federal law now requires disclosure of the warranty which applies to this product prior to the sale to a customer. Please leave this statement attached to the product and allow the buyer to remove it after purchase.

SMITHCO

Wayne, Pennsylvania 19087

