

Parts & Service



Super Star 3 Wheel Drive  
Quick Hitch  
42-000-E  
SN: 5584

January 2008

**Product Support:**

**Hwy 55 & Poplar Ave; Cameron WI 54822**

**1-800-891-9435 [productsupport@smithco.com](mailto:productsupport@smithco.com)**

# CONTENTS

Introduction	<b>Introduction .....</b>	<b>1-3</b>
	Introduction .....	1
	Safe Practices .....	2
Service	Specifications .....	3
	<b>Service .....</b>	<b>4-11</b>
	Maintenance .....	4-6
	Service Chart .....	7
	End User's Service Chart .....	8
	Adjustments .....	9-11
	Storage .....	11
	<b>Diagrams .....</b>	<b>12-15</b>
	Wiring Diagram .....	12-13
	Hydraulic Diagram .....	14-15
Diagrams	<b>Parts .....</b>	<b>16-45</b>
	Main Frame .....	16-17
	3 Wheel Drive Front Fork .....	18-19
	Linkage .....	20-21
	Gas Tank .....	22-23
	Oil Tank .....	24-25
	Pump and Engine .....	26-29
	Engine .....	30-31
	Rear Axle .....	32-33
	Rake Lift .....	34-35
	13-729 2-Bank Hydraulic Valve .....	36-37
	42-039 Front Wheel Motor .....	38-39
	42-002 Rear Wheel Motor .....	40-41
	42-302 Electric On-Off Valve .....	42-45
	<b>Reference .....</b>	<b>47-48</b>
Parts	Decal List .....	47
	Optional Equipment .....	47
	Quick Reference .....	48
	<b>Accessories .....</b>	<b>A-C</b>
Accessories	Plows .....	A1-A19
	Belly Attachments .....	B1-B29
	Rear Attachments (Quick Hitch) .....	C1-C37
	Warranty .....	Inside Back Cover
Reference		

Thank you for purchasing a **SMITHCO** product.

Read this manual and all other manuals pertaining to the Super Star carefully as they have safety, operating, assembly and maintenance instructions. Failure to do so could result in personal injury or equipment damage.

Keep manuals in a safe place after operator and maintenance personnel have read them. Right and left sides are from the operator's seat, facing forward.

All **SMITHCO** machines have a Serial Number and Model Number. Both numbers are needed when ordering parts. The serial number plate on the Super Star is located on the rear axle. Refer to engine manual for placement of engine serial number.

For easy access record your Serial and Model numbers here.

<b>SMITHCO</b>			<b>CE</b>
WAYNE, PENNSYLVANIA 19087 USA 610-688-4009 Fax 610-688-6069			
SERIAL NO.	kW/hp	DATE OF MFG.	
<input type="text"/>	<input type="text"/>	<input type="text"/>	
MODEL NO.	lb/kg Empty	lb/kg Full	
<input type="text"/>	<input type="text"/>	<input type="text"/>	

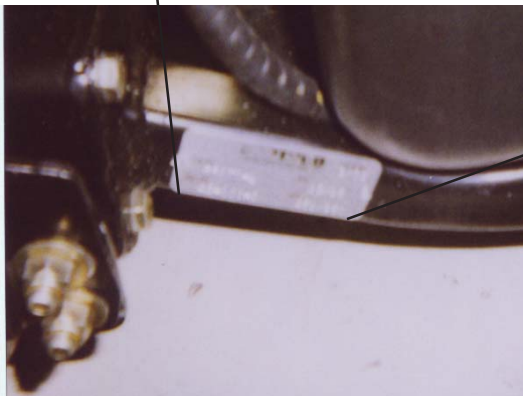

Information needed when ordering replacement parts:

1. Model Number of machine
2. Serial Number of machine
3. Name and Part Number of part
4. Quantity of parts

## SAFE PRACTICES

1. It is your responsibility to read this manual and all publications associated with this machine (engine, accessories and attachments).
2. Never allow anyone to operate or service the machine or its attachments without proper training and instructions. Never allow minors to operate any equipment.
3. Learn the proper use of the machine, the location and purpose of all the controls and gauges before you operate the equipment. Working with unfamiliar equipment can lead to accidents.
4. Wear all the necessary protective clothing and personal safety devices to protect your head, eyes, ears, hands and feet. Operate the machine only in daylight or in good artificial light.
5. Inspect the area where the equipment will be used. Beware of overhead obstructions and underground obstacles. Stay alert for hidden hazards.
6. Never operate equipment that is not in perfect working order or without decals, guards, shields, or other protective devices in place.
7. Never disconnect or bypass any switch.
8. Carbon monoxide in the exhaust fumes can be fatal when inhaled, never operate a machine without proper ventilation.
9. Fuel is highly flammable, handle with care.
10. Keep engine clean. Allow the engine to cool before storing and always remove the ignition key.
11. After engine has started, machine must not move. If movement is evident, the neutral mechanism is not adjusted correctly. Shut engine off and readjust so the machine does not move when in neutral position.
13. Never use your hands to search for oil leaks. Hydraulic fluid under pressure can penetrate the skin and cause serious injury.
14. This machine demands your attention. To prevent loss of control or tipping of the vehicle:
  - A. Use extra caution in backing up the vehicle. Ensure area is clear.
  - B. Do not stop or start suddenly on any slope.
  - C. Reduce speed on slopes and in sharp turns. Use caution when changing directions on slopes.
  - D. Stay alert for holes in the terrain and other hidden hazards.
15. Before leaving operator's position for any reason:
  - A. Disengage all drives.
  - B. Lower all attachments to the ground.
  - C. Shut engine off and remove the ignition key.
16. Keep hands, feet and clothing away from moving parts. Wait for all movement to stop before you clean, adjust or service the machine.
17. Keep the area of operation clear of all bystanders.
18. Never carry passengers.
19. Stop engine before making repairs/adjustments or checking/adding oil to the crankcase.
20. Use parts and materials supplied by SMITHCO only. Do not modify any function or part.

***These machines are intended for professional maintenance on golf courses, sports turf, and any other area maintained turf and related trails, paths and lots. No guaranty as to the suitability for any task is expressed or implied.***





## WEIGHTS AND DIMENSIONS

Length	64" (1.63 m)
Width	57" (1.45 m)
Height	47" (1.19 m)
Wheel Base	41" (1.04 m)
Weight	950 lbs. ( 451 kg)

## SOUND LEVEL

At Ear Level	87 dB
At 3ft (.914 m)	96 dB
At 30 ft (9.14 m)	84 dB

## ENGINE

Make	Briggs and Stratton Vanguard
Model#	303447
Type / Spec#	1131E1
Horsepower	16 hp (11.9 kW)
Fuel	Unleaded 87 Octane Gasoline Minimum
Cooling System	Air Cooled
Lubrication System	Full Pressure
Alternator	16 amp

## WHEELS & TIRE

Three: 22 X 11 - 10.0 Knobby Tires 5 psi (.35 bar)  
 Front tire fluid filled to 80 lbs. total 45.5 pints of windshield washer fluid or equivalent.

## Speed

Forward Speed	0 to 11 m.p.h. (0-18 kph)
Reverse Speed	0 to 5 m.p.h. (0-8 kph)

## BATTERY

Automotive Type	45-12 Volt
BCI Group	Size 45
Cold Cranking Amps	480
Ground Terminal Polarity	Negative (-)
Maximum Length	9" (23 cm)
Maximum Width	5.38" (14 cm)
Maximum Height	9" (23 cm)

## FLUID CAPACITY

Crankcase Oil	See Engine Manual
Fuel	20 quarts (18.93 liters)
Hydraulic Fluid	20 quarts (18.93 liters)
Grade of Hydraulic Fluid	SAE 10W-40 API Service SJ or higher Motor Oil

## MAINTENANCE



Before servicing or making adjustments to machine, stop engine and remove key from ignition.

**NOTE:** Use all procedures and parts prescribed by the manufacturer's. Read the engine manual.

### LUBRICATION

Use No. 2 General purpose Lithium Base Grease and lubricate every 100 hours. The Super Star has two grease fittings. One is located on the shift idler arm and one on the rod end of the attachment lift cylinder.

### AIR CLEANER ON ENGINE

1. Unhook clips on both sides of cover and remove cover.
2. Carefully slide pre-cleaner of cartridge. To service pre-cleaner, wash in liquid detergent and water. Squeeze dry in clean cloth. Saturate in engine oil. Squeeze in clean absorbent cloth to remove excess oil. Replace if very dirty or damaged.
3. Remove knob and plate. Carefully remove cartridge to prevent debris from entering carburetor. To service cartridge, clean by tapping gently on flat surface. Do not oil cartridge. Replace if very dirty or damaged.

**NOTE:** Do not use petroleum solvents, e.g., kerosene, which will cause cartridge to deteriorate. Do not use pressurized air to clean cartridge. Pressurized air can damage cartridge.

4. Reinstall cartridge, plate and knob.
5. Reassemble pre-cleaner on cartridge.
6. Replace cover and reattach clips to body.

### REMOTE AIR CLEANER

1. Unclip the two clips, remove the cover and pull out the element.
2. To service, clean by tapping gently on flat surface. Do not oil. Replace if very dirty or damaged.
3. Clean out the inside of the body and cover.
4. Place the element into the body and put the cover back on.

### TOWING

When it is necessary to move the Super Star without engine running, bypass valve built into hydrostatic pump must be "open" by turning it counterclockwise. The valve is located on the right side of the pump. An "open" valve allows fluid to pass through the wheels freely. When normal, driven, operation is desired, valve should be "closed" by turning it clockwise. Failure to "close" the valve with engine running means no power to wheels. The machine can be moved for a short distance with the engine off, but we **do not** recommend this as a standard procedure. When towing **do not** tow the machine faster than 2-3 MPH (3-5 km/h) because the drive system may be damaged. The tires may lock up if the machine is towed too fast. If this occurs, stop towing the machine. If the machine must be moved a considerable distance, transport it on a truck or trailer.

TIRE PRESSURE

Caution must be used when inflating a low tire to recommended pressure. Over inflating can cause tires to explode. Tires should be 5 psi (0.35 bar). Improper inflation will reduce tire life considerably.

ENGINE

Change and add oil according to chart below. Do not overfill. Use a high quality detergent oil classified "For Service SJ or higher" SAE 30 oil. Use no special additives with recommended oils. Do not mix oil with gasoline.

SAE VISCOSITY GRADES

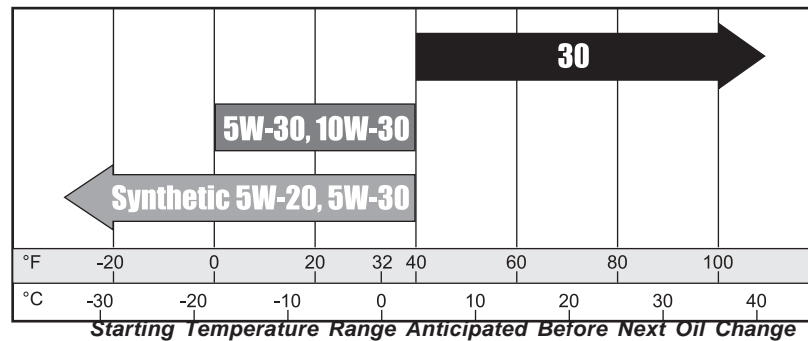

Air cooled engine run hotter than automotive engines. Use of multi-viscosity oils (10W-30, etc.) above 40° F (4° C) will result in high oil consumption and possible engine damage. Check oil level more frequently if using these types of oils.

SAE 30 oil, if used below 40° F (4° C), will result in hard starting and possible engine bore damage due to inadequate lubrication.

HYDRAULIC OIL

1. Use SAE 10W-40 API Service SJ or higher motor oil.
2. For proper warranty, change oil every 500 hours or annually, which ever is first and change filter after the first 20 hours, then at 100 hours, then every 250 hours thereafter.
3. The oil level should be 2" to 2 1/2" from top of tank when fluid is cold. Do not overfill.
4. After changing oil and/or filter, run the machine for a few minutes. Check oil level and for leaks.
5. Always use caution when filling hydraulic oil tank or checking level to keep system free of contaminants. Check and service more frequently when operating in extremely cold, hot or dusty conditions.
6. If natural color of fluid is black or smells burnt, it is possible that an overheating problem exists.
7. If fluid becomes milky, water contamination may be a problem.
8. If either of the above conditions happen, change oil and filter immediately after fluid is cool and find cause. Take fluid level readings when system is cold.
9. In extreme temperatures you can use straight weight oil. We recommend SAE 30W API Service SJ or higher when hot (above 90°F (33°C)) and SAE 10W API Service SJ or higher when cold (below 32°F (0°C) ambient temperature. Use either motor oil or hydraulic oil, but do not mix.
10. Oil being added to the system must be the same as what is already in the tank. Mark tank fill area as to which type you put in.

## MAINTENANCE

### WHEEL MOUNTING PROCEDURE

1. Turn machine off and remove key.
2. Block one of the other wheels.
3. Loosen nuts slightly on wheel to be removed.
4. Jack up machine being careful not to damage underside of machine.
5. Remove nuts. Remove wheel.
5. Place new wheel on hub lining up bolt holes.
6. Torque nuts to 64-74 ft/lb (87-100 Nm) using a cross pattern. Re-torque after first 10 hours and every 200 hours thereafter.
7. Lower machine to ground and remove blocks and jack.

### BATTERY

Batteries normally produce explosive gases which can cause personal injury. Do not allow flames, sparks or any ignited object to come near the battery. When charging or working near battery, always shield your eyes and always provide proper ventilation.

Battery cable should be disconnected before using "Fast Charge".

Charge battery at 15 amps for 10 minutes or 7 amps for 30 minutes. Do not exceed the recommended charging rate. If electrolyte starts boiling over, decrease charging.

Always remove grounded (-) battery clamp first and replace it last. Avoid hazards by:

1. Filling batteries in well-ventilated areas.
2. Wear eye protection and rubber gloves.
3. Avoid breathing fumes when electrolyte is added.
4. Avoid spilling or dripping electrolyte.



**WARNING**

**Battery Electrolyte is an acidic solution and should be handled with care. If electrolyte is splashed on any part of your body, flush all contact areas immediately with liberal amounts of water. Get medical attention immediately.**

### JUMPSTARTING



**WARNING**

**Use of booster battery and jumper cables. Particular care should be used when connecting a booster battery. Use proper polarity in order to prevent sparks.**

To jump start (negative grounded battery):

1. Shield eyes.
2. Connect ends of one cable to positive (+) terminals of each battery, first (A) then (B).
3. Connect one end of other cable to negative (-) terminal of "good" battery (C).
4. Connect other end of cable (D) to engine block on unit being started (NOT to negative (-) terminal of battery)

To prevent damage to other electrical components on unit being started, make certain that engine is at idle speed before disconnecting jumper cables.

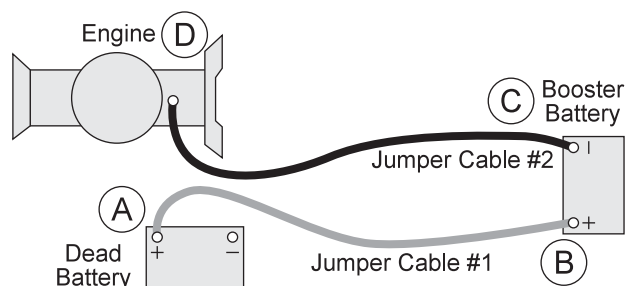



Before servicing or making adjustments to the machine, stop engine, set park break, block wheels and remove key from ignition.



Follow all procedures and **ONLY** use parts prescribed by the manufacturer. Read the engine manual before maintenance.

	Daily	As Required	100 Hours	200 Hours	250 Hours	300 Hours	400 Hours	Every 500 Hours/Yearly
⌘ Engine Oil	C	R	R	R	R	R	R	R
⌘ Engine Oil Filter			R	R		R	R	R
Engine for Leaks and Loose Parts	C		C	C		C	C	C
‡ Air Cleaner (Paper Element)		R	C	C		C	C	R
‡ Pre-Cleaner (Every 25 hours)		R	C	C		C	C	R
Spark Plugs							C	R
Valve Clearance								C
Idle Speed		C						C
Air Cooling System	C		C	C		C	C	C
Hoses	C				C			C
* Tire Pressure	C		C	C		C	C	C
Visual Inspection of Tires	C		C	C		C	C	C
Fuel Level	C	C						
Fuel Filter		R						R
Hydraulic Oil	C		C	C		C	C	R
† Hydraulic Oil Filter					R			R
Hydraulic System for Leaks and Loose Parts	C		C	C		C	C	C
Battery Electrolyte Level			C	C		C	C	C
Clean Battery Terminals					C			C
§ Torque Lug Nuts				C			C	C
Belt Tension and Visual Inspection			C	C		C	C	C
Lubricate			C	C		C	C	C

C=Check or Clean at specified intervals

R=Replace at specified intervals

\* Tire pressure: 5 psi (0.35 bar)

† Replace hydraulic filters after the first 20, 100, and every 250 there after.

§ Torque tire nuts after the first 10 hours and every 200 hours there after (64 to 74 ft/lb (87-100 Nm))

⌘ Change Oil and Filter after first 8 hours.

⌘ Change oil every 25 hours when operating under heavy load or in high ambient temperatures.

‡ Clean more often under dusty conditions or when airborne debris is present, replace air cleaner parts, if very dirty.

The suggested maintenance checklist is not offered as a replacement for the manufacturer's engine manual but as a supplement. You must adhere to the guidelines established by the manufacturer for warranty coverage. In adverse conditions such as dirt, mud or extreme temperatures, maintenance should be more frequent.



# END USER'S SERVICE CHART

Service

	Daily	As Required	25 Hours	50 Hours	100 Hours	200 Hours	250 Hours	Every 500 Hours/Yearly
£ Engine Oil (Change every 50 hours)								
¤ Engine Oil Filter								
Engine for Leaks and Loose Parts								
‡ Air Cleaner (Paper Element)								
‡ Pre-Cleaner (Every 25 hours)								
Spark Plugs								
Valve Clearance								
Idle Speed								
Belt Tension and Visual Inspection								
Air Cooling System								
Hoses								
*Tire Pressure								
Visual Inspection of Tires								
Fuel Level								
Fuel Filter								
†Hydraulic Oil								
Hydraulic System for Leaks and Loose Parts								
Battery Electrolyte Level								
Clean Battery Terminals								
§Torque Lug Nuts								
Lubricate								

C=Check or Clean at specified intervals

R=Replace at specified intervals

\* Tire pressure: 5 psi (0.35 bar)

† Replace hydraulic filters after the first 20, 100, and every 250 there after.

§ Torque tire nuts after the first 10 hours and every 200 hours there after (64 to 74 ft/lb (87-100 Nm))

¤ Change Oil and Filter after first 8 hours.

£ Change oil every 25 hours when operating under heavy load or in high ambient temperatures.

‡ Clean more often under dusty conditions or when airborne debris is present , replace air cleaner parts, if very dirty.



## RAKE LIFT CYLINDER

Completely lower Rake Lift. Remove the clevis pin (A). Twist lift linkage (C) so clevis pin end of cylinder extension lines up with holes in attachment lift arm. Replace clevis and cotter pins. Raise and lower Rake Lift to check for proper clearance.



**When the rear rake attachment is lowered while the machine is in forward motion, the forward speed of the machine will slow drastically. Operator should be prepared for a rapid change in speed.**

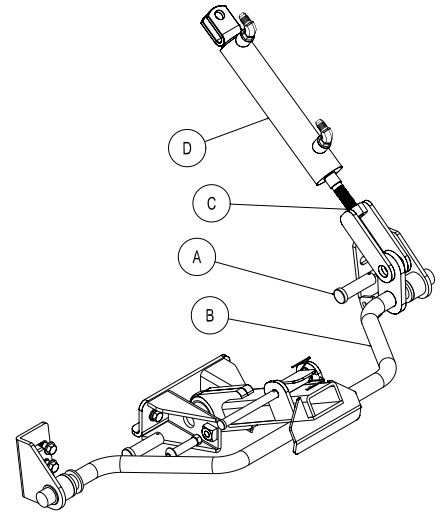

## STEERING CHAIN ADJUSTMENT

You will have to remove the nose cone assembly to get at steering sprockets. Steering Sprockets (A) should be level with each other. Check with straight edge. Make any adjustments. Adjust the chain tensioner bolt (B) so that the chain is snug. Tighten all nuts and bolts in place.

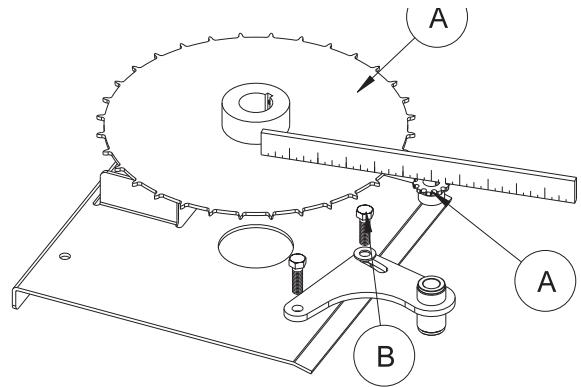

## SPEED BOSS

Speed Boss allows the machine to operate at a proper speed while raking sand traps on golf courses. This speed boss has been factory set at an average speed of 3-4 m.p.h. (5-6.5 kph). The Speed Boss will only limit the speed while the rake is lowered into the operating position. The speed setting may be adjusted by turning the Ball Joint (A) counterclockwise to make the machine operate slower or turn clockwise to go faster. Tighten jam nut. Check to make sure nothing is binding and test drive to check desired speed.

For RBS System, Spiker and Grader Box remove the speed boss arm and the speed boss rod from machine so it does not interfere with other operations.

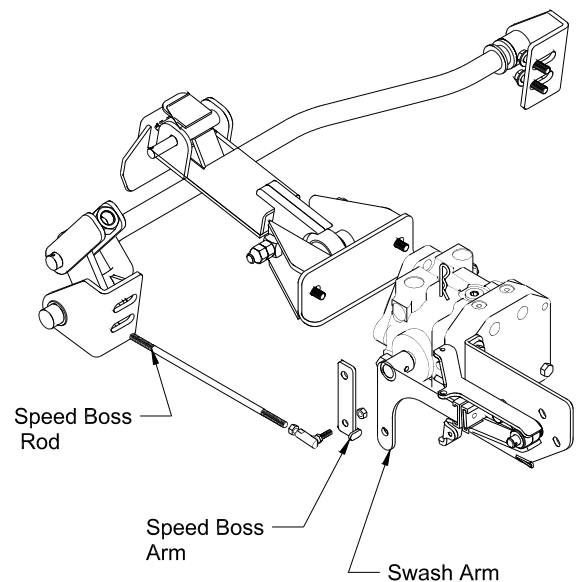

## ADJUSTMENTS (CONTINUED)

### WHEEL 'CREEP' ADJUSTMENT

'Creep' is when engine is running and hydrostatic transmission is in neutral, but due to inadequate alignment, wheels still move. Do the following procedures to stop this motion.

1. Lift up and support machine so all wheels are off the ground and can turn freely.
2. On the side of the pump there is a creep arm inside a centering arm. Loosen bolt (A).
3. With engine running adjust the creep arm up or down in slot so centering arm centers on the swash arm.
4. Tighten all fasteners and test by using foot pedal linkage to see that the "creep" is removed.
5. Turn engine off and lower machine.

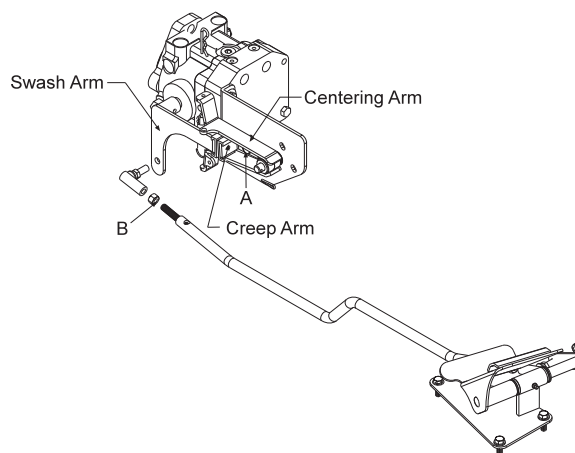

### PARK BRAKE

The park brake is located on the right hand side of the machine and operates a brake on the right rear wheel. Push lever forward to engage and pull back to disengage.

To adjust turn the knob on the end of the handle. For further adjustment you may turn the yokes (A) clockwise to tighten and counter clockwise to loosen.

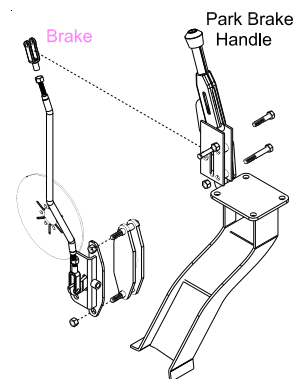

### ADJUSTMENT OF BELT TENSIONER

The belt tensioner controls the tension on the belt from the engine to the pump. The proper tension of the idler should be in the second notch on the side of the tensioner. Over tightening the belt will shorten the life of the belt and the machine may not perform to the best of its ability. To adjust belt tensioner, loosen the bolt holding the tensioner (A). Bring idler pulley tight to the belt and turn tensioner into belt to the second notch. Tighten bolt on tensioner.

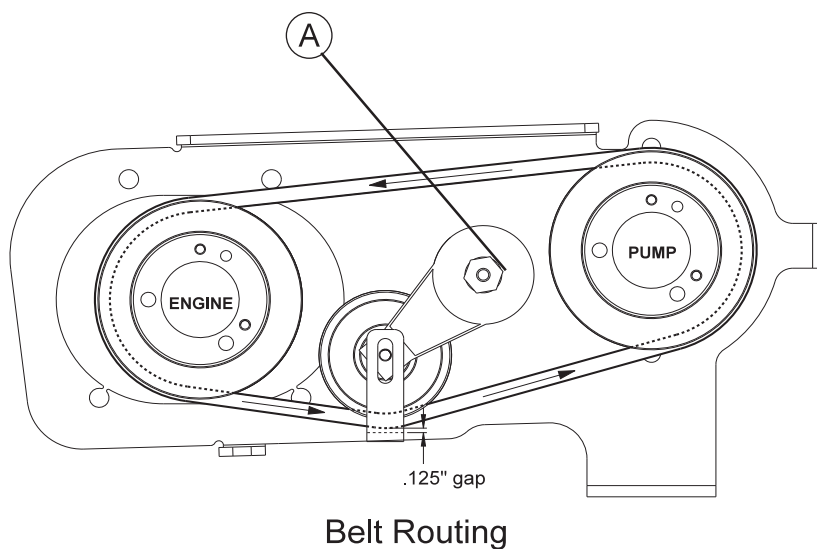



## ADJUSTMENTS (CONTINUED)

### TO ADJUST FOOT PEDAL THROTTLE CABLE

1. Jack up unit so that all drive wheel are off the ground. (Use jack stands)
2. Start the engine, make certain that the hand throttle is in the idle position (1200 engine RPM).
3. Engine speed must increase as soon as the foot pedal begins to move in either direction. At the full forward position, the engine RPM must be 3600 RPM  $\pm$  100.
4. Minor adjustment can be made by backing out (un-screwing) (Ref A) until you reach full engine RPM with the foot pedal fully depressed in the forward position. Be sure to recheck after the nuts are fully tightened.
5. Major adjustment needs to be made at (Ref B) by pulling the slack out of the cable. Loosen the screw in the wire block that is clamped onto the end of the cable and sliding it up to the cable block that is through the throttle plate. Do not let the throttle plate move to increase idle speed. Tighten the screw.
6. Test run to determine that there is no binding and that engine idle speed is 1200 RPM and that it is 3600 RPM at full forward position of the foot pedal.

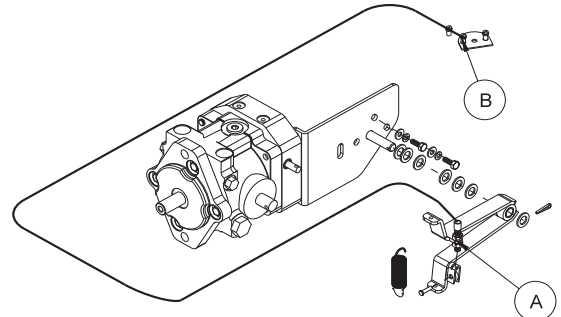

Service

## STORAGE

When storing, remove the key from the key switch to avoid unauthorized persons from operating machine.

1. Before storing clean machine thoroughly.
2. Check bolts and nuts, tighten as necessary.
3. Make all repairs that are needed and remove any debris.
4. Remove the battery, adjust the electrolyte level and recharge it. Store the battery in a dry, dark place.
5. Store in a clean and dry area, but NOT near a stove, furnace or water heater which uses a pilot light or any device that can create a spark.
6. Engines stored over 30 days need to be protected or drained of fuel to prevent gum from forming in a fuel system or on essential carburetor parts. Check the engine manual and follow the instructions for the storage of the engine.

# WIRING DRAWING

Diagrams

## Color Code Chart

Bl	Blue
Br	Brown
Y	Yellow
Grn	Green
O	Orange
R	Red
B	Black
P	Purple
W	White

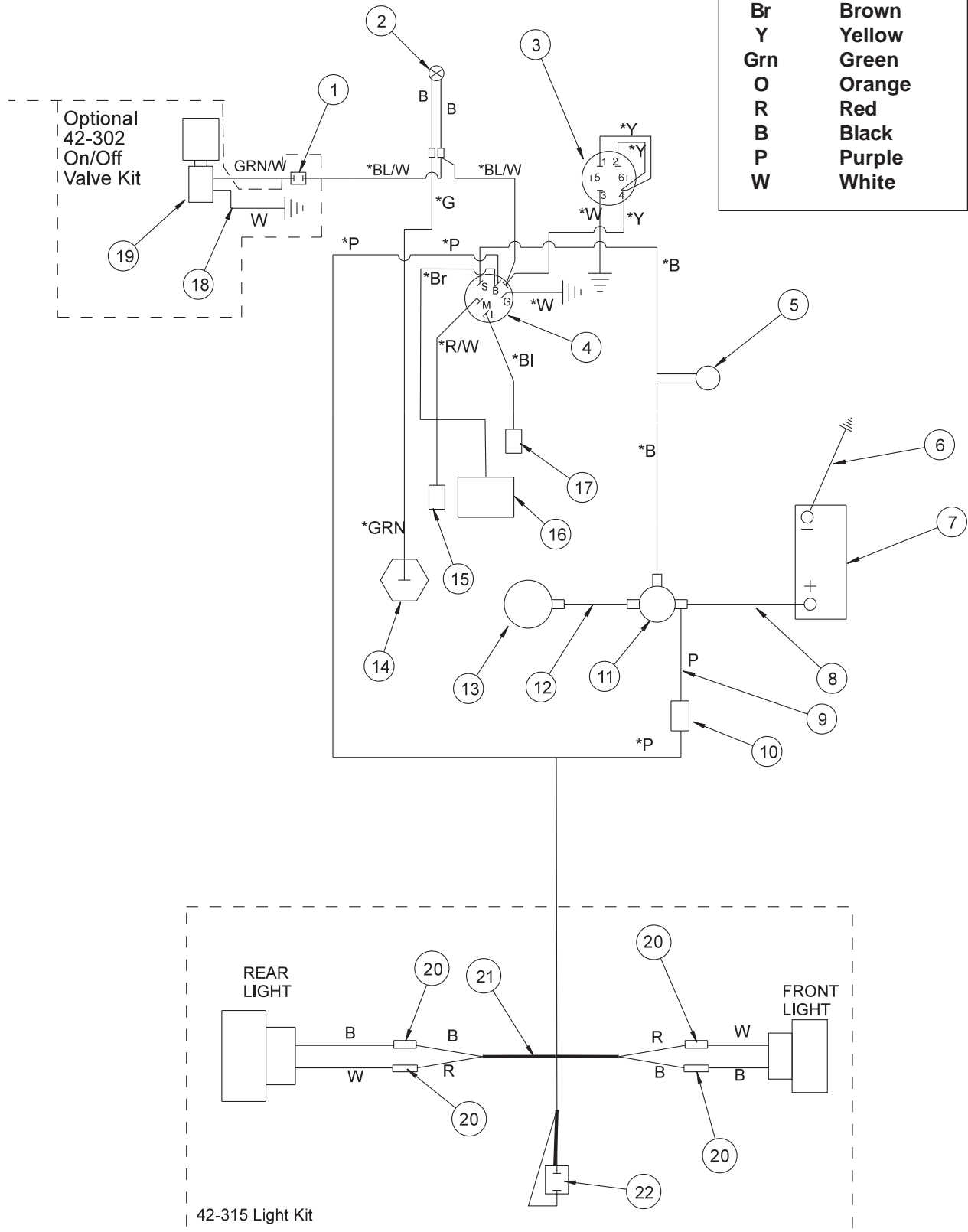

# WIRING PARTS LIST

REF #	PART #	DESCRIPTION	QUANTITY
1	12-003	Toggle Switch (part of 42-302 Kit)	1
	15-472	Switch Boot	1
2	50-359	Oil Pressure Warning Light	1
3	12-017	Hour/ Volt Meter Combo	1
4	13-488	Ignition Switch (B & S# 692318)	1
	76-310	Key Set (comes with 13-488)	1
5	14-292	Seat Switch	1
6	76-327	Ground Battery Cable	1
7		Battery (not included)	
8	75-518	Battery Cable	1
9	42-252	Wire, Circuit Breaker to Solenoid	1
10	8975	30 Amp Circuit Breaker	1
	8977	Circuit Breaker Boot	1
11	13-492	Solenoid (B & S# 807829)	1
12	22-017	Cable Black	1
13		Starter (on engine)	1
14	13-491	Oil Sender (on engine B & S# 491657)	1
15		Stop Switch Terminal (on engine)	1
16		Rectifier (on engine)	1
17		After Fire Solenoid (on engine)	1
18	76-260	Ground Wire (part of 42-302 Kit)	1
19	42-118	Electric On/Off Valve (part of 42-302 Kit)	1
	42-763	Wire Harness (includes all wire colors with *)	1
	42-387	Wire Harness Solenoid to ENgine	1

# HYDRAULIC DRAWING

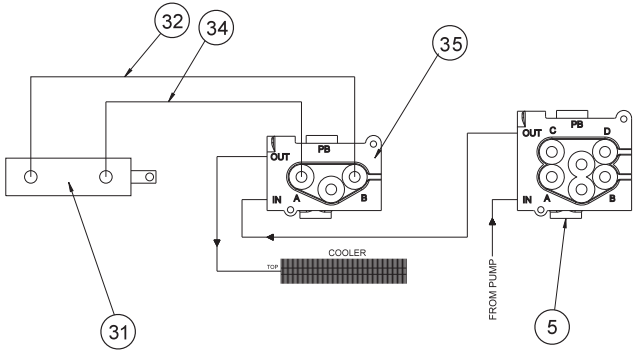
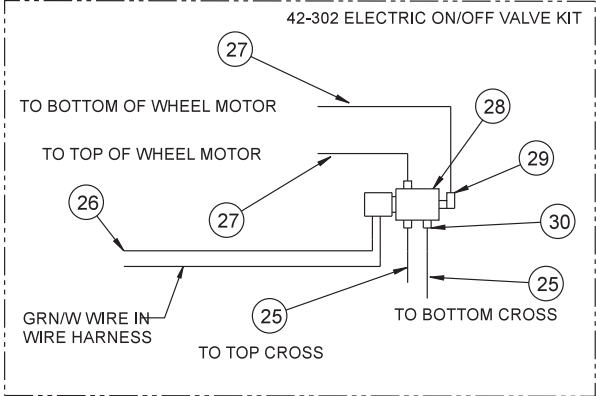

Diagrams

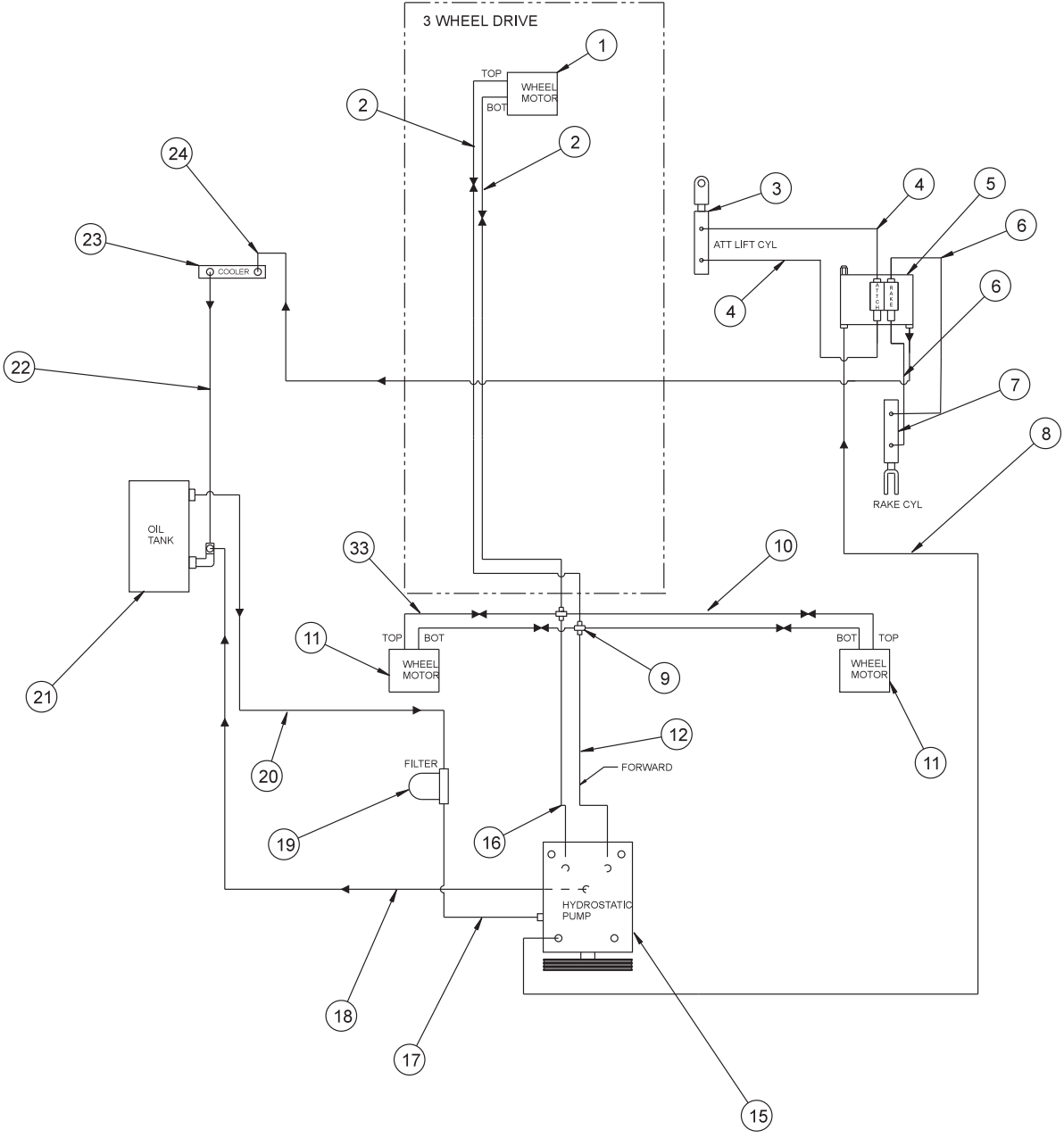

# HYDRAULIC PARTSLIST

REF #	PART #	DESCRIPTION	QUANTITY
1	42-039	Front Wheel Motor (3 wheel drive only)	1
2	42-262	Hydraulic Hose (3 wheel drive only)	2
3	10-135	Hydraulic Cylinder	1
	18-154	Rod End	1
	HNJ-58-18	Jam Nut 5/8 - 18	1
4	42-047	Hydraulic Hose	2
5	13-729	2 - Bank Hydraulic Valve	1
	78-417	Valve Handle	2
6	42-048	Hydraulic Hose	2
7	43-150	Hydraulic Cylinder	1
8	42-044	Hydraulic Hose	1
9	18-342	Cross	2
10	42-261	Hydraulic Tube	2
11	42-002	Rear Wheel Motor	2
12	42-259	Hydraulic Hose 10 <sup>3</sup> / <sub>4</sub> "	1
15	42-599	Variable Pump	1
16	42-258	Hydraulic Hose 9"	1
17	8832-45	Suction Hose	1
	18-222	Hose Clamp	2
18	42-787	Hydraulic Hose	1
19	23-006	Oil Filter	1
	23-031	Replacement Filter Only	
20	8832-24	Suction Hose	1
	18-222	Hose Clamp	2
21	42-005	Oil Tank	1
	13-747	Filler Breather	1
22	42-256	Hydraulic Hose	1
23	42-265	Aluminum Oil Cooler	1
24	42-045	Hydraulic Hose	1
33	42-304	Hydraulic Tube	2
42-302 ELECTRIC ON/OFF VALVE KIT			
25	42-263	Hydraulic Hose	2
26	76-260	Ground Wire	1
27	42-264	Hydraulic Hose	2
28	42-118	Electric On/Off Valve	1
29	18-185	Elbow 90°	1
30	18-341	Elbow 45°	3
HYDRAULIC PLOW			
31	13-292	Hydraulic Cylinder	1
32	43-049	Hydraulic Hose 18"	1
34	43-048	Hydraulic Hose 20"	1
35	13-731	Single Bank Valve	1
HYDRAULIC PRESSURES			
Pump Displacement	.913 in <sup>3</sup> /rev	Charge Pump Displacement	.33 in <sup>3</sup> /rev
Pump Input Speed (up to)	3600 rpm	Max. Inlet Vacuum	5 in. Hg
Max. Operating Pressure	2500 psi	Max. Case Pressure	25 psi
Implement Setting	700-1000 psi	Relief Valve Pressure (set at)	2500 psi
13-729 Hydraulic Valve (2 bank)	900 psi		

# MAIN FRAME COMMON DRAWING

Parts

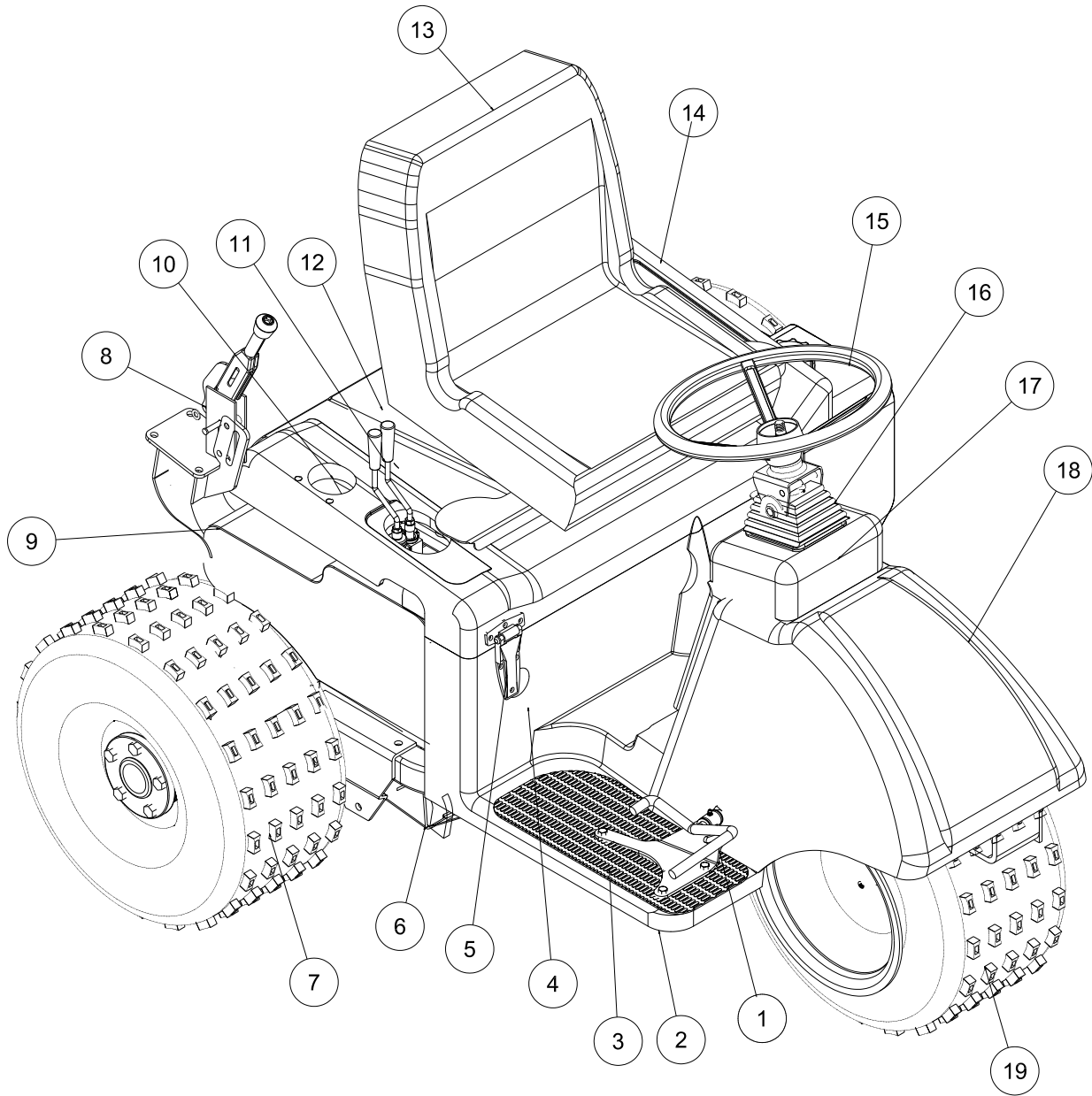

## MAIN PARTS COMMON LIST

REF#	PART#	DESCRIPTION	QUANTITY
1	42-790	Foot Pedal	1
2	42-780	Floor Panel (fiberglass)	1
3	42-767	Right Floor Mat	1
	42-768	Left Floor Mat	1
4	12-017	Hour Meter	1
5	27-055	Hinge	2
6	42-595	Main Frame (3WD)	1
7	42-161	Knobby Tire and Wheel	2
	42-161-01	Tire 22 x 11 - 10 Knobby Type	2
	42-161-02	Wheel	2
8	60-106	Park Brake Lever	1
9	42-006	Gas Tank	1
	15-492	Cap	1
10	42-786	Plastic Cup Holder	1
11	78-418	Valve Handle	2
12	42-772	Seat Panel	1
	8803-17	Trim w/ Black Lace	1
13	14-518	Adjustable Low Back Seat	1
14	42-779	Seat Panel (fiberglass)	1
15	13-718	Steering Wheel	1
16	76-364	90° Black Boot (comes with 76-362)	1
	76-362	Tilt Steering Mechanism	1
17	42-782	Console (fiberglass)	1
18	42-471	Nose Cone (fiberglass)	1
	HSTP-14-20-100	Truss Head Screw <sup>1</sup> / <sub>4</sub> - 20 x 1	6
	78-274	Cage Nuts	2
	HNTL-14-20	Lock Nut <sup>1</sup> / <sub>4</sub> - 20	4
19*	42-161	Knobby Tire and Wheel	1
	42-161-01	Tire 22 x 11 - 10 Knobby Type	1
	42-161-02	Wheel	1
* Front tire and wheel are fluid filled to 80 lbs. total.			
	8839	Windshield Washer Fluid or Equivalent	45.5 pints



# 3 WHEEL DRIVE FRONT FORK DRAWING

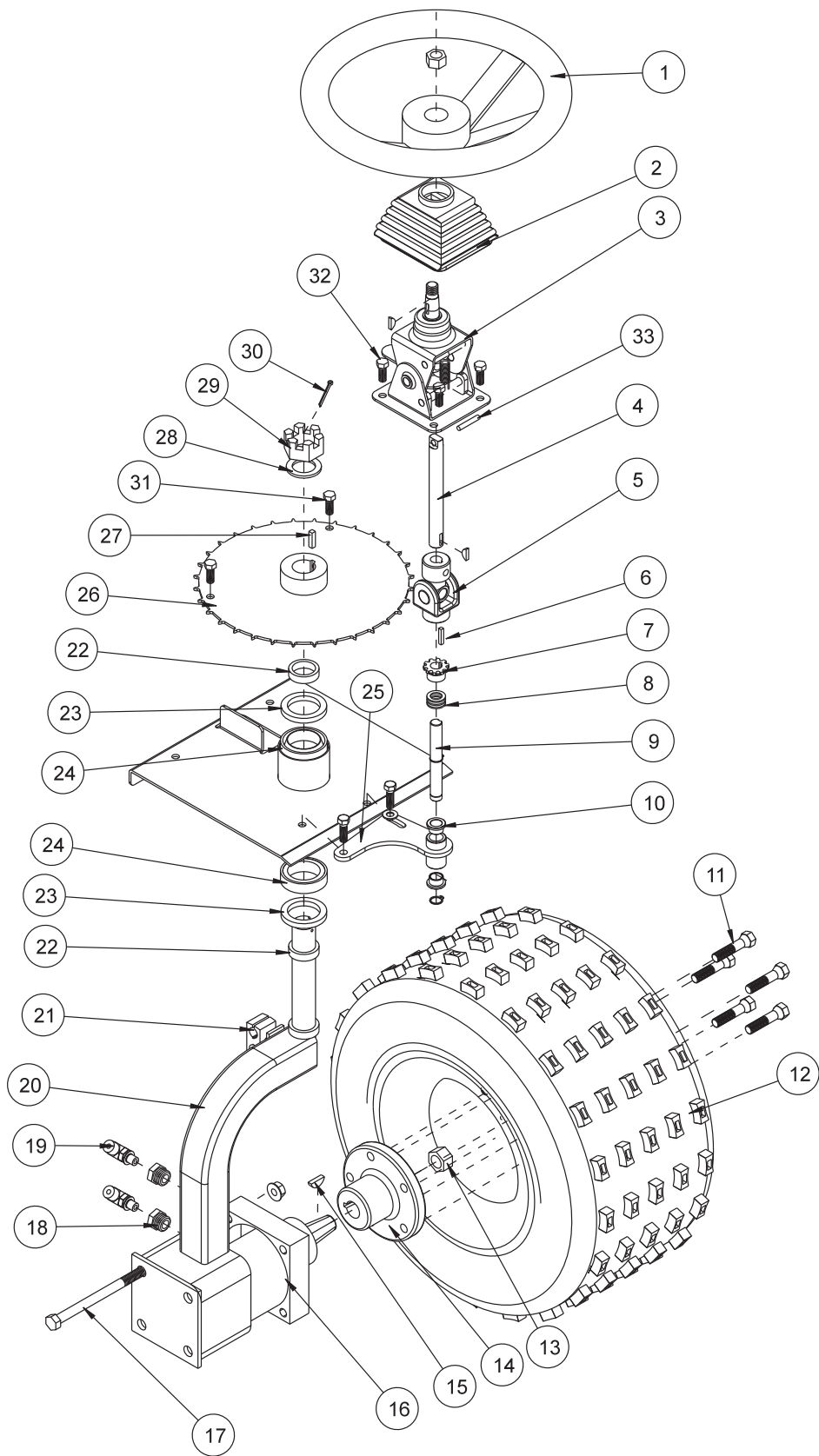

Parts



## 3 WHEEL DRIVE FRONT FORK PARTSLIST

REF#	PART#	DESCRIPTION	QUANTITY
1	13-718	Steering Wheel 13"	1
	13-726	Center Cap	1
	27-077	Decal, Smithco Round	1
	HNJ-58-11	Jam Nut <sup>5</sup> / <sub>8</sub> - 11	1
	HWK-316-075	Woodruff Key <sup>3</sup> / <sub>16</sub> X <sup>3</sup> / <sub>4</sub>	1
2	76-364	Tilt Steering Boot (comes with 76-362)	1
3	76-362	Tilt Steering Mechanism	1
4	42-760	Top Steering Shaft	1
	HWK-316-075	Woodruff Key <sup>3</sup> / <sub>16</sub> X <sup>3</sup> / <sub>4</sub>	1
5	60-300	U-Joint	1
6	HKSQ-316-100	Machine Key <sup>3</sup> / <sub>16</sub> X <sup>3</sup> / <sub>16</sub> X 1	2
7	60-298	Sprocket	1
8	HMB-58-14	Machine Bushing <sup>5</sup> / <sub>8</sub> X 14 GA	3
9	42-034	Bottom Steering Shaft	1
	HRR-58	Snap Ring <sup>5</sup> / <sub>8</sub>	2
10	18-384	Flange Bushing (part of 42-266)	2
11	60-268	Lug Bolts <sup>1</sup> / <sub>2</sub> - 20 x <sup>1</sup> / <sub>5</sub>	5
12	42-161	Knobby Tire and Wheel	1
	42-161-01	Tire 22 x 11 - 10 Knobby Type	1
	42-161-02	Wheel	1
	8839	Windshield Washer Fluid or Equivalent	43.5 pints
13	42-002-12	Nut <sup>3</sup> / <sub>4</sub> - 16 (part of 42-039)	1
14	42-007	Hub	1
15	HWK-14-100	Woodruff Key <sup>1</sup> / <sub>4</sub> - 1 (part of 42-039)	1
16	42-039	Wheel Motor	1
	18-350	90° Seal Lok Elbow	2
17	HB-12-13-650	Bolt <sup>1</sup> / <sub>2</sub> - 13 x 6 <sup>1</sup> / <sub>2</sub>	4
	HNTL-12-13	Lock Nut <sup>1</sup> / <sub>2</sub> - 13	4
18	18-172	Reducer	2
19	18-171	Seal Lock Elbow	2
20	42-022	Front Fork	1
21	13-652	Hose Clamp	1
22	20-141	Spacer	2
23	20-142	Oil Seal	2
24	20-143	Bearing	2
25	42-266	Chain Tensioner	1
	HB-38-16-125	Bolt <sup>3</sup> / <sub>8</sub> - 16 x 1 <sup>1</sup> / <sub>4</sub>	2
	HW-38	Washer <sup>3</sup> / <sub>8</sub>	1
	HNFL-38-16	Flange Whiz Lock Nut <sup>3</sup> / <sub>8</sub> - 16	2
26	42-295	Steering Sprocket	1
	8834-37.5	#35 Roller Chain	1
	18-114	Master Link	1
27	HKSQ-14-100	Square Key <sup>1</sup> / <sub>4</sub> X <sup>1</sup> / <sub>4</sub> X 1	1
28	HMB-114-10	Machine Bushing 1 <sup>1</sup> / <sub>4</sub> X 10GA	1
29	HNA-114-12	Axle Nut 1 <sup>1</sup> / <sub>4</sub> - 12	1
30	HP-18-200	Cotter Pin <sup>1</sup> / <sub>8</sub> X 2	1
31	HB-38-16-100	Bolt <sup>3</sup> / <sub>8</sub> - 16 x 1	2
	HNFL-38-16	Flange Whiz Lock Nut <sup>3</sup> / <sub>8</sub> - 16	2
32	HB-516-18-125	Bolt <sup>5</sup> / <sub>16</sub> - 18 x 1 <sup>1</sup> / <sub>4</sub>	2
	HNTL-516-18	Lock Nut <sup>5</sup> / <sub>16</sub> - 18	2
31	HRP-14-150	Roll Pin <sup>1</sup> / <sub>4</sub> X 1 <sup>1</sup> / <sub>2</sub>	1



# LINKAGE DRAWING

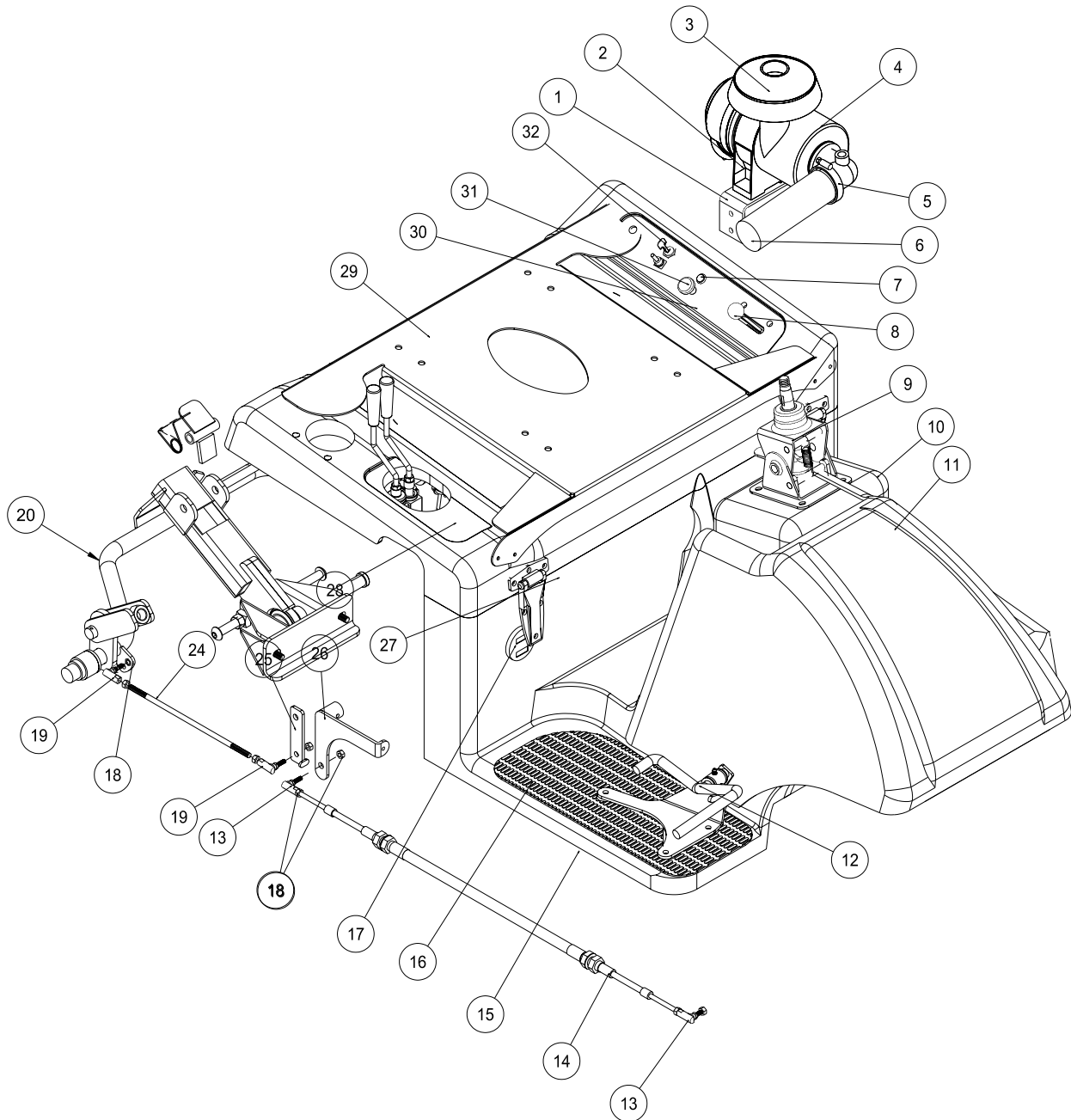

Parts

# LINKAGE PARTSLIST

REF#	PART#	DESCRIPTION	QUANTITY
1	42-769	Oil Tank Bracket	1
	HB-516-18-100	Bolt <sup>5</sup> / <sub>16</sub> - 18 x 1	2
	HNFL-516-18	Flange Whiz Lock Nut <sup>5</sup> / <sub>16</sub> - 18	2
2	42-076-01	Band	1
3	42-076-02	Hat	1
4	42-076	Air Cleaner	1
	42-076-03	Replacement Filter	
	13-603	Air Cleaner Base (comes with engine)	1
5	18-123	Hose Clamp	2
6	8959-26	Flex Hose x 26"	1
	27-113	Air Cleaner Hose Elbow	1
	42-776	Air Cleaner Hose Sleeve	1
7	50-359	Warning Light	1
8	42-789	Throttle Cable	1
	42-766	Throttle Bracket	1
	HSTP-14 -20-075	Phillips Truss Head Screw <sup>1</sup> / <sub>4</sub> - 20 x <sup>3</sup> / <sub>4</sub>	2
	HNFL-14-20	Flange Whiz Lock Nut <sup>1</sup> / <sub>4</sub> - 20	2
9	76-362	Tilt Steering	1
	76-364	Boot Black (comes with 76-362)	1
10	42-782	Console (fiberglass)	1
11	42-471	Nose Cone (fiberglass)	1
12	42-790	Foot Pedal	1
	HG-14-28-180	Grease Fitting <sup>1</sup> / <sub>4</sub> - 28 x 180° (comes with 42-790)	1
	76-299	Pedal Pad Long	1
	42-791	Pedal Pad Short	1
	HB-516-18-150	Bolt <sup>5</sup> / <sub>16</sub> - 18 x 1 <sup>1</sup> / <sub>2</sub>	2
	HW-516	Washer <sup>5</sup> / <sub>16</sub>	2
	HNFL-516-18	Flange Whiz Lock Nut <sup>5</sup> / <sub>16</sub> -18	2
13	18-115	Ball Joint <sup>1</sup> / <sub>4</sub> - 28	2
14	27-132	Cable	1
15	42-780	Floorboard (fiberglass)	1
16	42-767	Right Floor Mat	1
	42-768	Left Floor Mat	1
17	12-017	Hour Meter	1
18	HN-14-28	Nut <sup>1</sup> / <sub>4</sub> -28	4
	HWL-14	Lockwasher <sup>1</sup> / <sub>4</sub>	2
19	18-387	Spring Loaded Ball Joint <sup>5</sup> / <sub>16</sub> - 24	2
20	43-137	Lift Bar	1
24	43-147	Speed Boss Rod	1
25	42-249	Speed Boss Arm	1
26	42-308	Swash Arm	1
27	27-055	Hinge	2
	HSMFCS-10-32-100	Machine Screw #10 - 32 x 1	12
	HNFL-10-32	Flange Lock Nut #10 - 32	12
28	42-765	Decal, Lift Controls	1
29	42-779	Seat Panel	1
30	42-593	Decal, Control Panel	1
31	42-783	Choke	1
32	13-488	Key Switch (B&S 692318)	1
	76-310	Key Set	1

# GAS TANK DRAWING

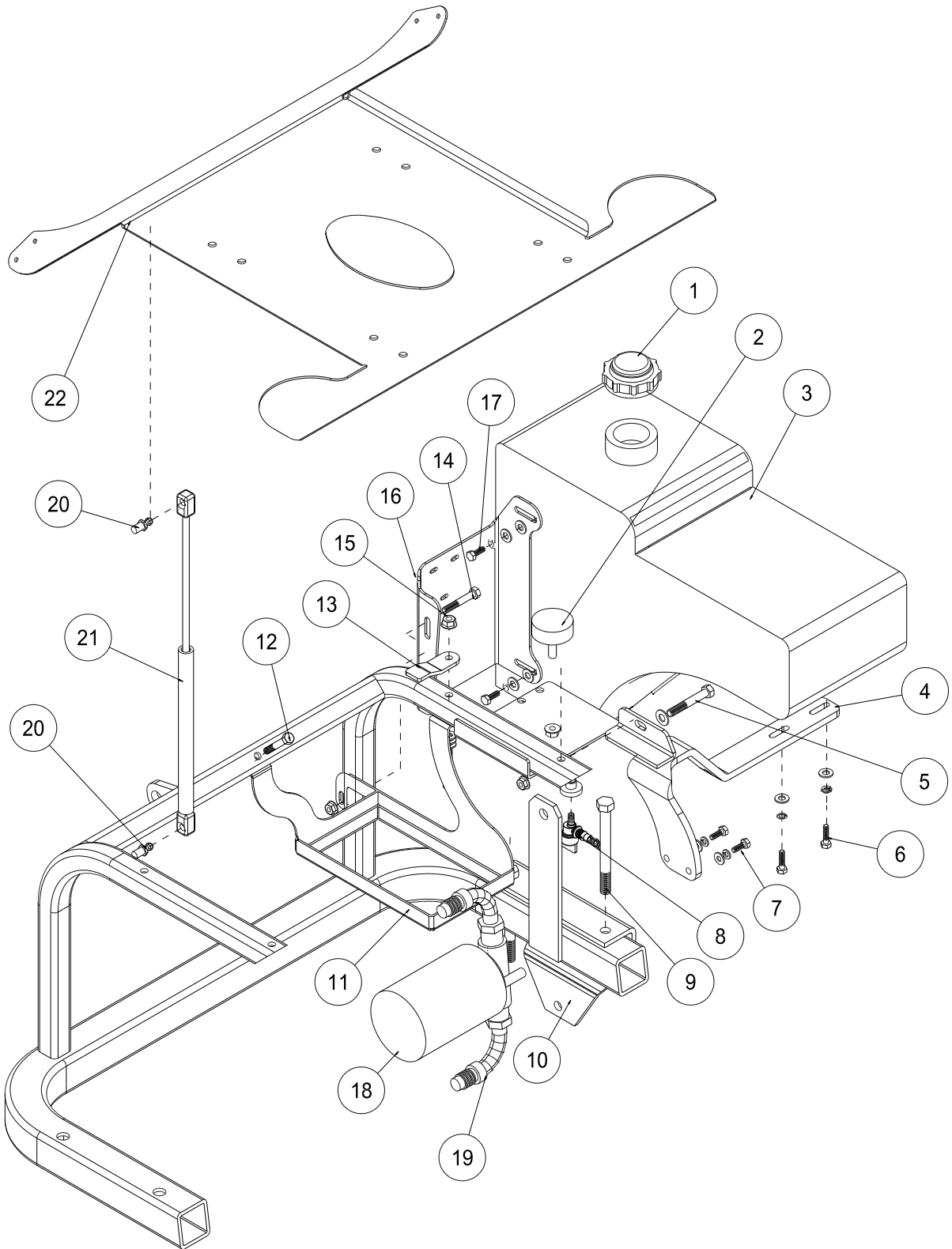

Parts

## GAS TANK PARTSLIST

REF#	PART#	DESCRIPTION	QUANTITY
1	42-014	Cap	1
2	50-081	Rubber Bumper	1
	HNFL-38-16	Flange Whiz Lock Nut $\frac{3}{8}$ - 16	1
3	42-006	Gas Tank	1
4	42-770	Right Tank Support	1
5	HB-38-16-250	Bolt $\frac{3}{8}$ - 16 x $2\frac{1}{2}$	1
	HW-38	Washer $\frac{3}{8}$	2
	HNFL-38-16	Flange Whiz Lock Nut $\frac{3}{8}$ - 16	1
6	HB-14-20-100	Bolt $\frac{1}{4}$ - 20 x 1	2
	HW-14	Washer $\frac{1}{4}$	2
	HW-516	Washer $\frac{5}{16}$	2
	HWL-14	Lock Washer $\frac{1}{4}$	2
7	HB-14-20-075	Bolt $\frac{1}{4}$ - 20 x $\frac{3}{4}$	2
	HWL-14	Lockwasher $\frac{1}{4}$	2
	HW-14	Washer $\frac{1}{4}$	2
8	26-055	Fuel Shut Off (comes with 42-006)	1
	26-054	Rubber Grommet (comes with 42-006)	1
	8800-41	Fuel Hose	1
	18-186	Hose Clamp	2
9	HB-12-13-500	Bolt $\frac{1}{2}$ - 13 x 5	2
	HNFL-12-13	Flange Whiz Lock Nut $\frac{1}{2}$ - 13	2
10	42-015	Attachment Mount	1
11	42-273	Battery Box	1
12	HB-516-18-200	Bolt $\frac{5}{16}$ - 18 x 1	1
	HNFL-516-18	Flange Whiz Lock Nut $\frac{5}{16}$ - 18	1
13	42-248	Battery Hold-down	1
	15-020	Grip	1
14	HB-516-18-225	Bolt $\frac{5}{16}$ - 18 x $2\frac{1}{4}$	2
	HNFL-516-18	Flange Whiz Lock Nut $\frac{5}{16}$ - 18	2
15	HB-516-18-225	Bolt $\frac{5}{16}$ - 18 x $2\frac{1}{4}$	1
	HW-516	Washer $\frac{5}{16}$	3
	HNFL-516-18	Flange Whiz Lock Nut $\frac{5}{16}$ - 18	1
16	42-773	Gas Tank Bracket	1
17	HB-14-20-075	Bolt $\frac{1}{4}$ - 20 x $\frac{3}{4}$	2
	HW-14	Washer $\frac{1}{4}$	2
	HWL-14	Lock Washer $\frac{1}{4}$	2
18	23-006	Oil Filter	1
	23-031	Replacement Filter	1
19	34-123	Elbow	2
20	26-034	Ball Stud	2
21	13-569	Gas Shock	1
22	42-772	Seat Panel	1



# OIL TANK DRAWING

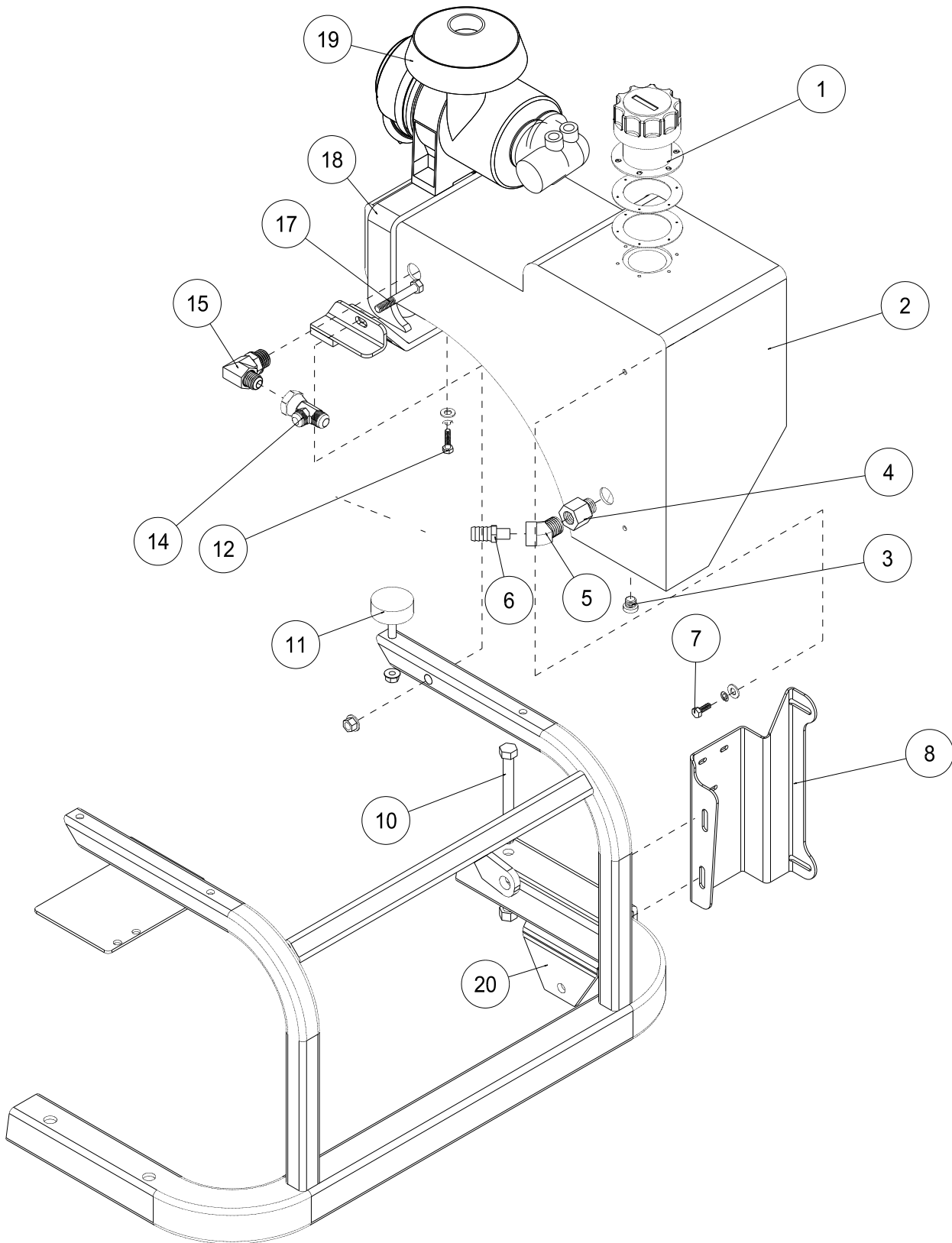

Parts

## OIL TANK PARTSLIST

REF#	PART#	DESCRIPTION	QUANTITY
1	13-747	Filler Breather	1
	13-586-03	Neck	1
	HSM-8-32-050	Machine Screw #8 - 32 x 1/2	6
	HWS-8	Star Washer #8	6
2	42-005	Oil Tank	1
3	23-126	#6 Plug	1
4	18-240	Adapter	1
5	18-072	45° Elbow	1
6	18-133	Barb Fitting	1
7	HB-14-20-075	Bolt 1/4 - 20 x 3/4	2
	HW-14	Washer 1/4	2
	HWL-14	Lock Washer 1/4	2
8	42-774	Oil Tank Bracket	1
	HB-516-18-225	Bolt 5/16 - 18 x 2 1/4	2
	HNFL-516-18	Flange Whiz Lock Nut 5/16 - 18	2
10	HB-12-13-500	Bolt 1/2 - 13 x 5	2
	HNTL-12-13	Top Lock Nut 1/2 - 13	2
11	50-081	Rubber Bumper	1
	HNFL-38-16	Flange Whiz Lock Nut 3/8 - 16	1
12	HB-14-20-100	Bolt 1/4 - 20 x 1	2
	HW-516	Washer 5/16	2
	HW-14	Washer 1/4	2
	HWL-14	Lock Washer 1/4	2
14	18-337	Tee	1
15	23-189	90° Elbow	1
17	HB-38-16-250	Bolt 3/8 - 16 x 2 1/2	1
	HW-38	Washer 3/8	1
	HNFL-38-16	Flange Whiz Lock Nut 3/8 - 16	1
18	42-769	Left Tank Bracket	1
19	42-076	Remote Air Cleaner	1
20	42-015	Attachment Mount	2

# PUMP AND ENGINE DRAWING (3WD)

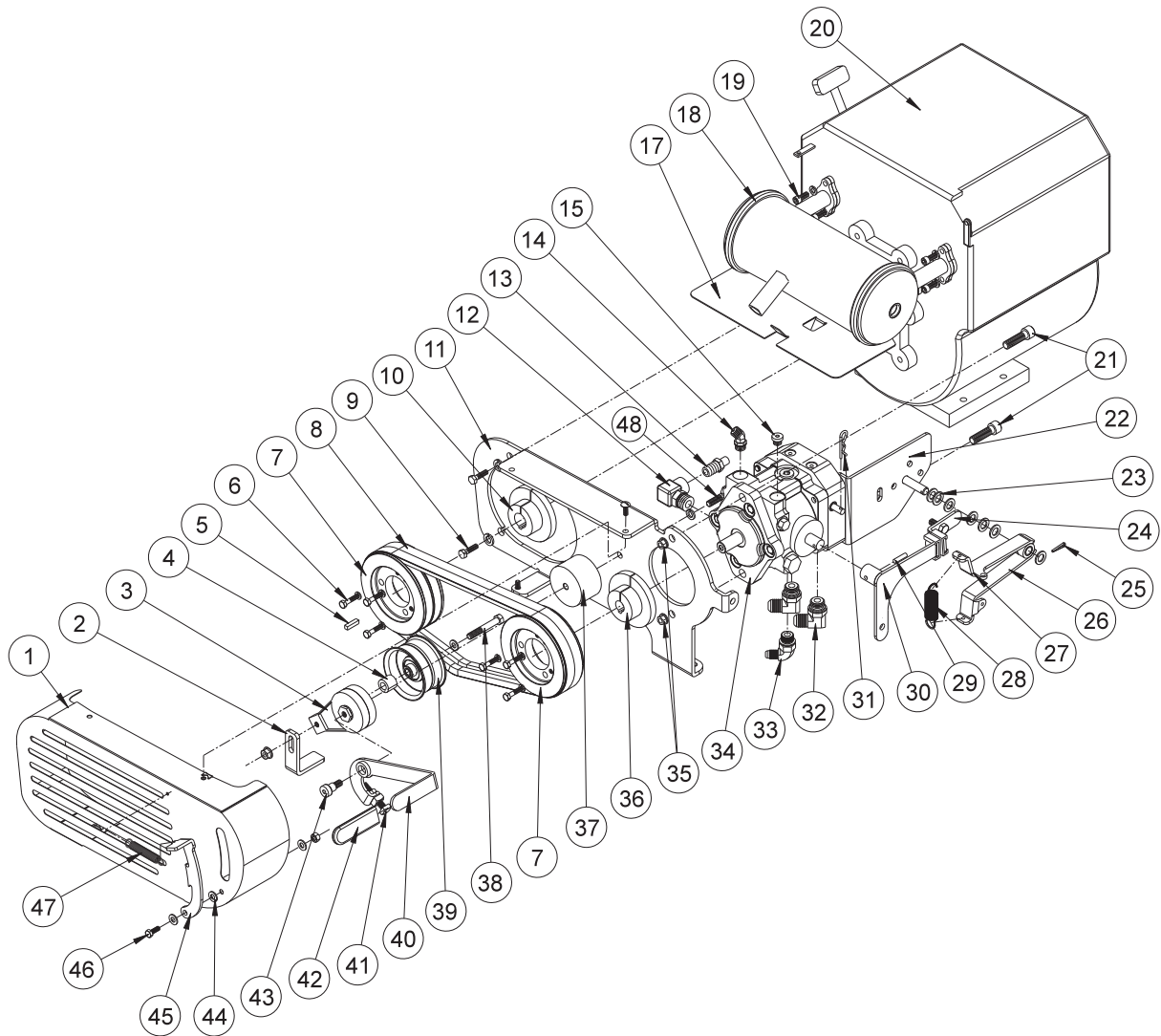

Parts

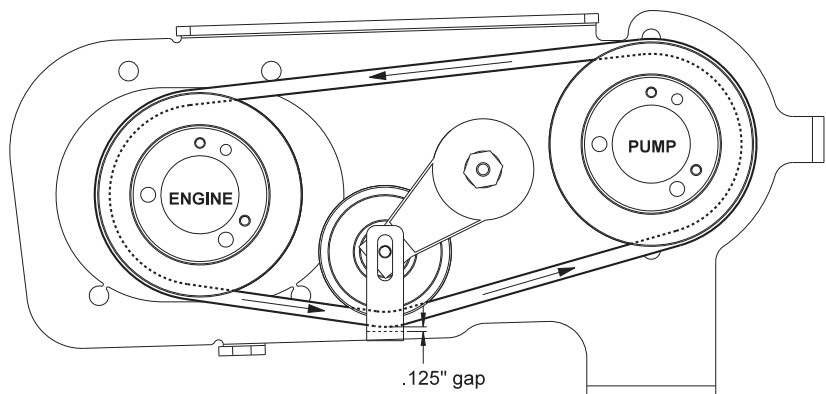

Belt Routing



## PUMP AND ENGINE PARTS LIST (3WD)

REF#	PART#	DESCRIPTION	QUANTITY
1	42-353	Belt Guard	1
	78-274	Cage Nut	2
	HB-14-20-075	Hex Bolt, $\frac{1}{4}$ - 20 x $\frac{3}{4}$	2
	HWL-14	Lock Washer, $\frac{1}{4}$	2
2	42-357	Belt Stop	1
3	42-327	Tensioner	1
4	16-990	Spacer	1
5	HKSQ-14-100	Machine Key $\frac{1}{4}$ x $\frac{1}{4}$ x 1	1
6	HB-14-20-125	Bolt $\frac{1}{4}$ - 20 x $1\frac{1}{4}$ (comes with 42-245 & 42-246)	6 (3 per hub)
	HW-14	Lockwasher (comes with 42-245 & 42-246)	6 (3 per hub)
7	42-331	Pulley	2
8	42-359	Belt	2
9	HB-716-14-100	Bolt $\frac{7}{16}$ - 14 x 1	4
	HWL-716	Lockwasher $\frac{7}{16}$	4
10	42-245	Hub 1"	1
11	42-354	Pump Mount	1
12	23-130	Elbow 90°	1
13	18-133	Barb Fitting	1
14	18-188	Elbow 45°	1
15	23-126	Plug	1
17	42-306	Heat Shield	1
	18-222	Hose Clamp	2
18	27-123	Muffler	1
19	HSSHSM-8-1.25-20	Metric Cap Screw M8 - 1.25 x 20	4
	HWLM-8	Lockwasher M8	4
20	15-165	Engine B&S 16 HP	1
	15-165-01	Air Filter Element with Pre-Cleaner (comes with engine)	1
	13-531	Engine Oil Filter (comes with engine)	1
	13-491	Oil Switch (comes with engine)	1
	13-492	Solenoid	1
21	HSSHHS-12-13-175	Socket Screw $\frac{1}{2}$ - 13 x $1\frac{3}{4}$	2
22	42-279	Filter Mount	1
	HW-38	Washer $\frac{3}{8}$	2
23	HMB-12-14	Machine Bushing $\frac{1}{2}$ x 14 GA	7
24	42-247	Creep Arm	1
	8946-1.5	Wear Strip (part of 42-247)	1
	HRS-316-050	Rivet (part of 42-247)	1
	HB-38-16-100	Bolt $\frac{3}{8}$ - 16 x 1	2
	HNFL-38-16	Flange Whiz Lock Nut $\frac{3}{8}$ - 16	2
25	HP-18-100	Cotter Pin $\frac{1}{8}$ x 1	1
26	42-312	Bottom Centering Arm	1
	18-234	Bushing (part of 42-312)	1
27	42-311	Top Centering Arm	1
	18-234	Bushing (part of 42-311)	1
28	11-050	Extension Spring	1
29	HRP-14-100	Roll Pin $\frac{1}{4}$ x 1	1
30	42-308	Swash Arm	1
	8946-1	Wear Strip (part of 42-308)	1
	HRS-316-050	Rivet (part of 42-308)	1

(Continued on next page)

# PUMP AND ENGINE DRAWING (3WD)

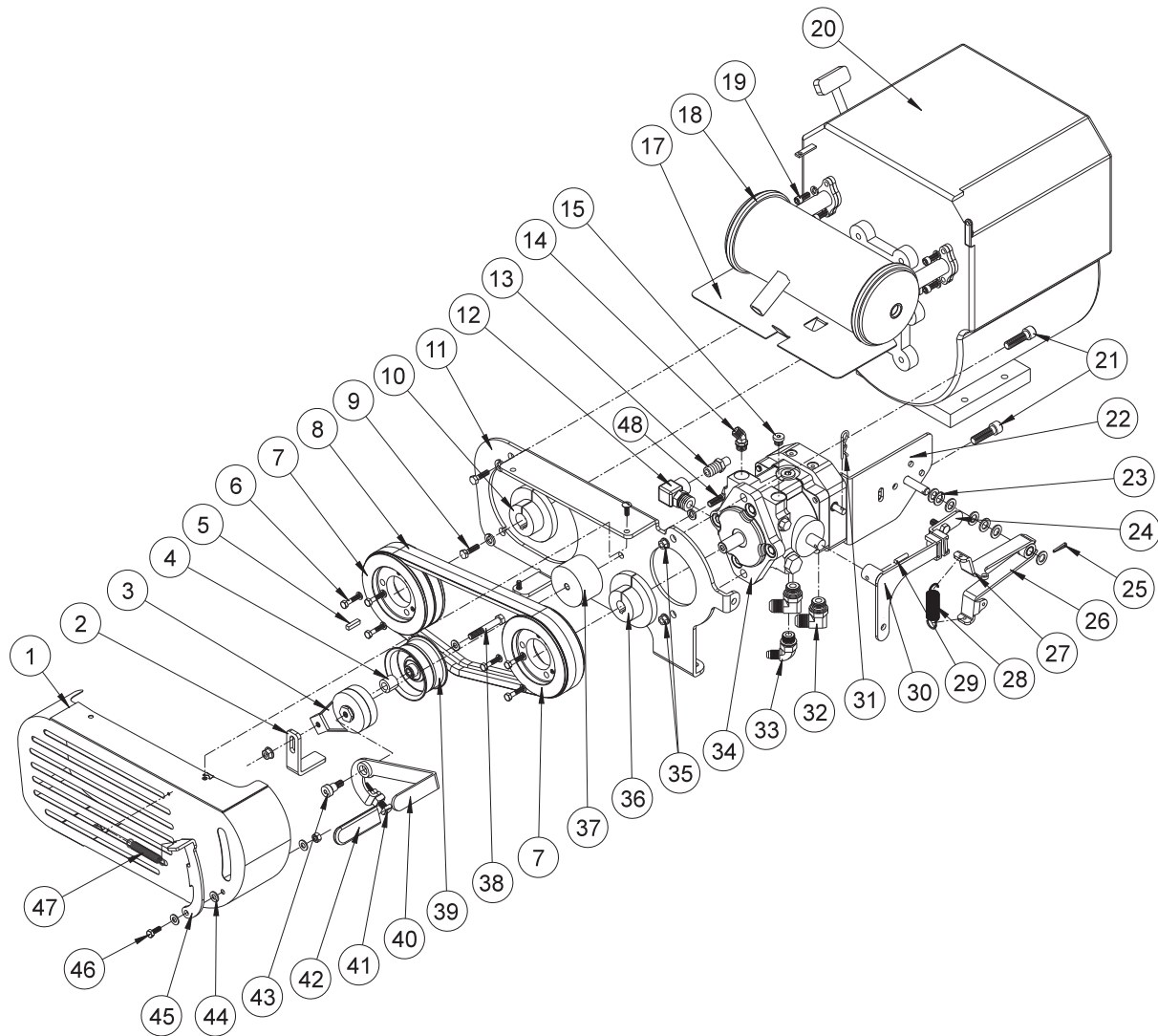

Parts

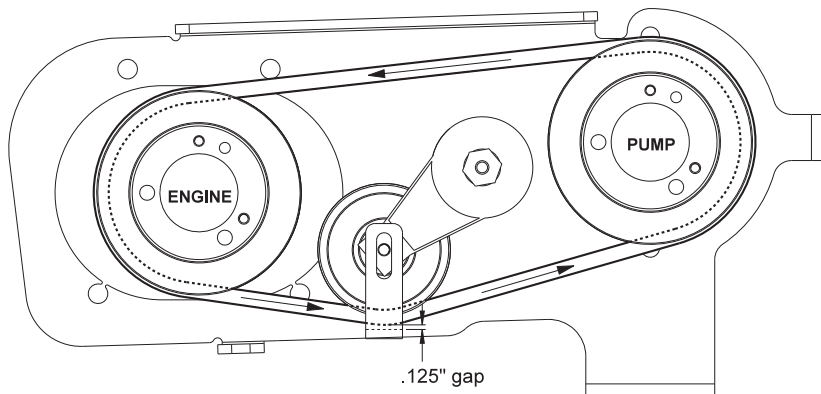

Belt Routing

## PUMP AND ENGINE PARTS LIST (3WD)

REF#	PART#	DESCRIPTION	QUANTITY
31	HHP-18	Bridge Pin $\frac{1}{8}$	1
32	18-174	Elbow 90°	2
33	18-185	Elbow	1
34	42-599	Variable Pump (3WD)	1
	34-109	variable Pump (2WD)	
35	HNTL-12-13	Lock Nut $\frac{1}{2}$ - 13	2
36	42-246	Hub $\frac{3}{4}$	1
	HWK-316-075	Woodruff Key	1
37	42-361	Tensioner Spacer	1
38	HB-38-16-275	Hex Bolt, $\frac{3}{8}$ -16 x $2\frac{3}{4}$	1
	HNFL-38-16	Flange Whiz Lock Nut, $\frac{3}{8}$ -16	1
	HW-38	Flat Washer, $\frac{3}{8}$	1
39	42-358	Idler Pulley	1
	42-338	Oilite Bushing	1
40	42-355	Clutch Handle	1
41	HSSQ-38-16-200	Socket Head Square Screw $\frac{3}{8}$ - 16 x 2	1
	HN-38-16	Hex Nut, $\frac{3}{8}$ - 16	1
42	15-020	Grip	1
43	42-352	Hex Socket Head shoulder Screw	1
44	HW-38	Flat Washer, $\frac{3}{8}$	3
45	42-356	Lock Handle	1
46	HB-516-18-075	Hex Bolt, $\frac{5}{16}$ -18 x $\frac{3}{4}$	1
	HNTL-516-18	Lock Nut, $\frac{5}{16}$ -18	1
47	16-046	Spring	1
48	HB-38-16-250	Hex Bolt, $\frac{3}{8}$ -16 x $2\frac{1}{2}$	1
	HWL-38	Lock Washer, $\frac{3}{8}$	1

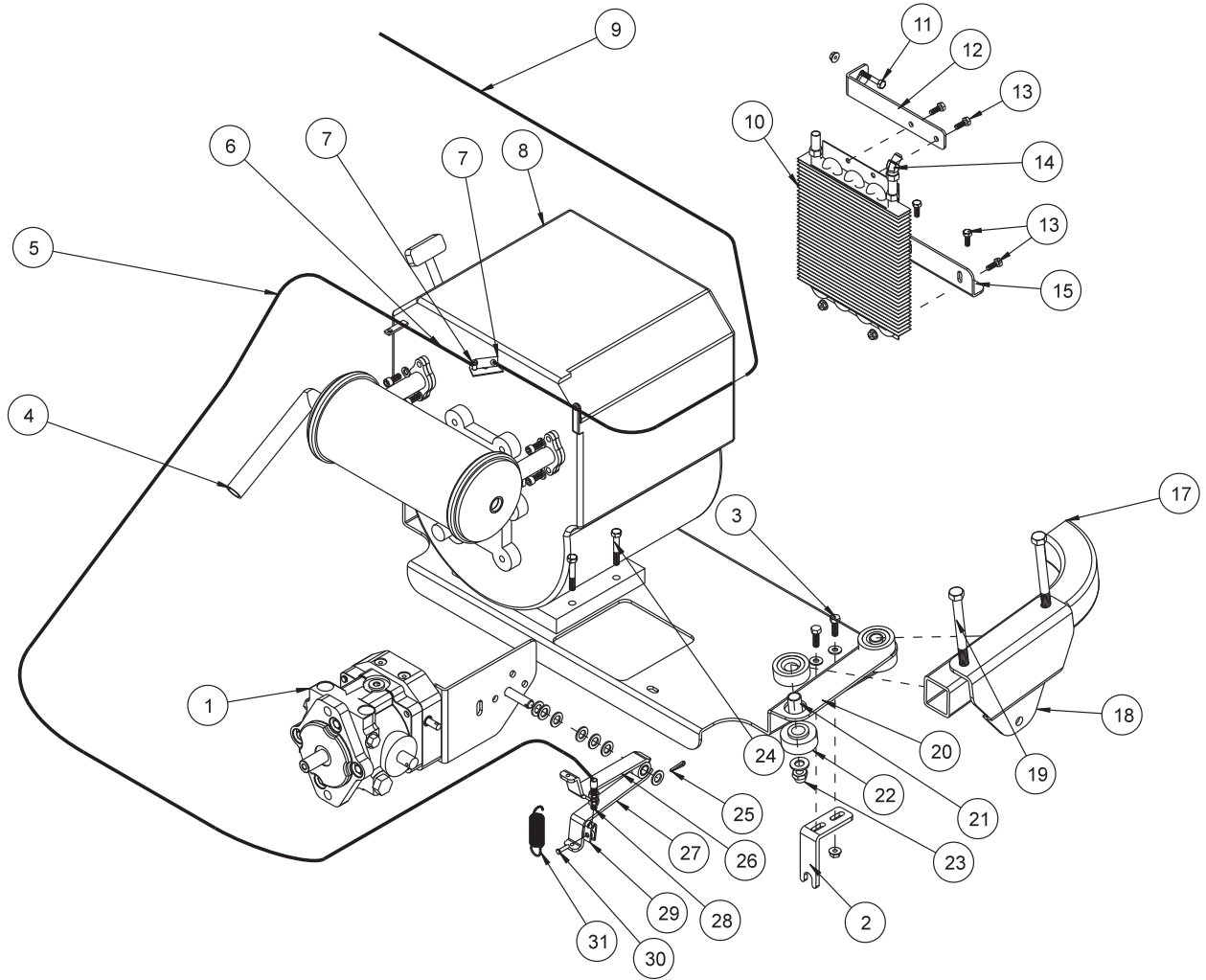

REF #	PART #	DESCRIPTION	QUANTITY
1	42-599	Variable Pump	1
2	42-307	Cable Bracket	1
3	HB-516-18-100	Bolt $\frac{5}{16}$ - 18 x 1	2
	HW-516	Washer $\frac{5}{16}$	2
	HNTL-516-18	Lock Nut $\frac{5}{16}$ - 18	2
4	27-123	Muffler	1
5	17-152	Conduit	1
6	17-151	Cable	1
7	21-161	Wire Block	4
8	15-165	Engine B&S 16 hp	1
9	42-789	Throttle (hand)	1
10	42-265	Aluminum Oil Cooler	1
11	HB-14-20-150	Bolt $\frac{1}{4}$ - 20 x $1\frac{1}{2}$	1
	HNFL-14-20	Flange Whiz Lock Nut $\frac{1}{4}$ -20	1
12	42-771	Top Cooler Bracket	1
13	HB-14-20-075	Bolt $\frac{1}{4}$ - 20 x $\frac{3}{4}$	4
	HNFL-14-20	Flange Whiz Lock Nut $\frac{1}{4}$ - 20	4
14	18-214	Elbow 45°	1
15	42-275	Bottom Cooler Bracket	1
17		Main Frame	
18	42-015	Attachment Mount	2
19	HB-12-13-500	Bolt $\frac{1}{2}$ -13 x 5	4
20	42-269	Engine Plate	1
21	60-168	Spacer	4
22	60-107	Rubber Bushing	8
23	HNTL-12-13	Lock Nut $\frac{1}{2}$ - 13	4
	HW-12	Washer $\frac{1}{2}$	4
24	HB-516-18-225	Bolt $\frac{5}{16}$ - 18 x $2\frac{1}{4}$	4
	HNFL-516-18	Flange Whiz Lock Nut $\frac{5}{16}$ - 18	4
25	HP-18-100	Cotter Pin $\frac{1}{8}$ x 1	1
	HMB-12-14	Machine Bushing $\frac{1}{2}$ x 14 GA	7
26	42-311	Top Centering Arm	1
	18-234	Bushing (part of 42-311)	1
27	42-312	Bottom Centering Arm	1
	18-234	Bushing (part of 42-312)	1
28	17-155	Retainer	1
	HN-516-24	Nut $\frac{5}{16}$ - 24	2
29	17-153	Clevis	1
30	HCP-14-075	Clevis Pin $\frac{1}{4}$ x $\frac{3}{4}$	1
	HP-332-075	Cotter Pin $\frac{3}{32}$ x $\frac{3}{4}$	1
31	11-050	Extension Spring	1

# REAR AXLE DRAWING

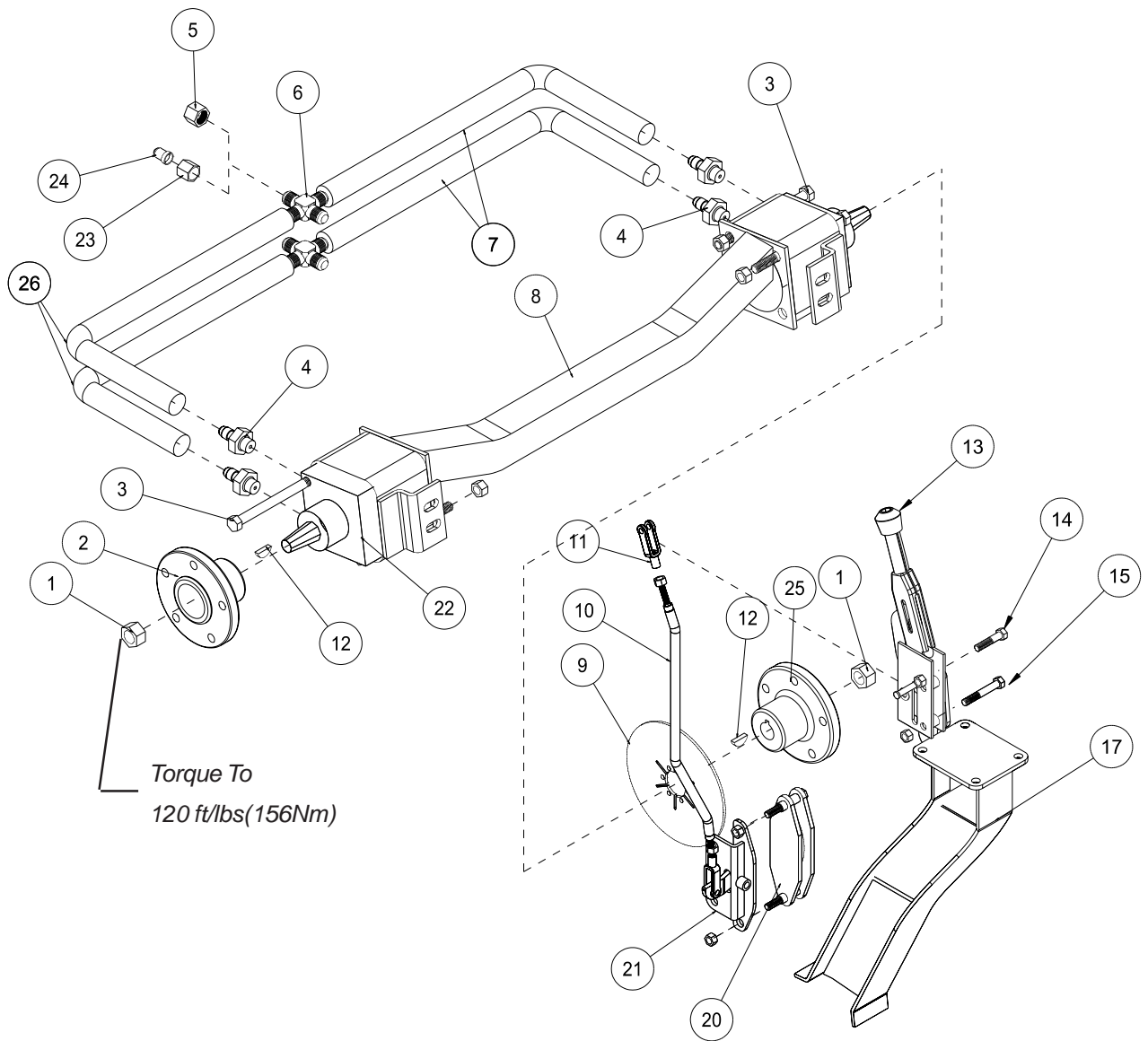

Parts

## REAR AXLE PARTSLIST

REF#	PART#	DESCRIPTION	QUANTITY
1	42-002-12	Nut $\frac{3}{4}$ - 16 (part of 42-002)	2
2	42-007	Hub	1
	42-305	Shim	1
3	HB-12-13-650	Bolt $\frac{1}{2}$ - 13 x 6 $\frac{1}{2}$	8
	HNTL-12-13	Top Lock Nut $\frac{1}{2}$ - 13	8
4	18-343	Adapters	4
5	18-344	Caps (2WD ONLY)	2
6	18-342	Cross	2
7	42-261	$\frac{1}{2}$ " Hydraulic Tube x 27 $\frac{1}{2}$ "	2
8	42-595	Main Frame	1
9	50-041	Brake Disk	1
	42-176	Low Head Cap Screw $\frac{1}{4}$ - 20 x $\frac{3}{4}$	6
10	42-804	Brake Rod	1
	HN-516-24	Nut $\frac{5}{16}$ - 24	2
11	11-100	Linkage Yoke	2
	HCP-516-100	Clevis Pin $\frac{5}{16}$ x 1	2
	HP-18-100	Cotter Pin $\frac{1}{8}$ x 1	2
12	HWK-14-100	Woodruff Key 1/4 x 1 (part of 42-002)	2
13	60-106	Brake Lever	1
14	HB-516-18-175	Bolt $\frac{5}{16}$ - 18 x 1 $\frac{3}{4}$	1
	HNFL-516-18	Flange Whiz Lock Nut $\frac{5}{16}$ - 18	1
15	HB-516-18-250	Bolt $\frac{5}{16}$ - 18 x 2 $\frac{1}{2}$	1
	HNFL-516-18	Flange Whiz Lock Nut $\frac{5}{16}$ - 18	1
17		Main Frame	1
20	50-042	Brake Caliper	1
21	42-151	Brake Bracket	1
22	42-002	Wheel Motor	2
23	23-120	$\frac{1}{2}$ " Tube Nut (3WD only)	2
24	34-128	Reducer (3WD only)	2
25	42-157	Right-hand Hub	1
	42-305	Shim	1
26	42-304	$\frac{1}{2}$ " Hydraulic Tube x 27"	2

# RAKE LIFT DRAWING

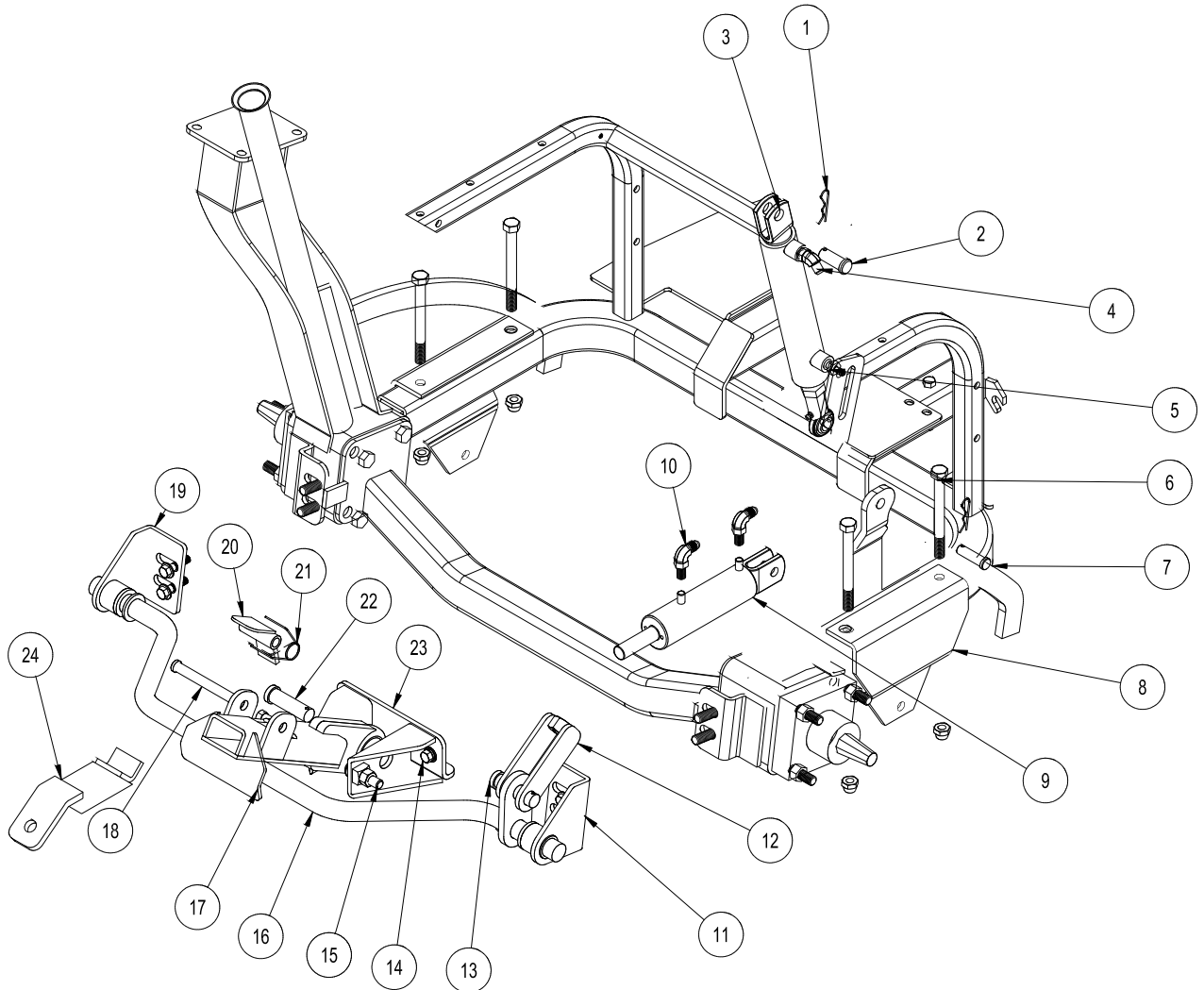

Parts



## RAKE LIFT PARTS LIST

REF#	PART#	DESCRIPTION	QUANTITY
1	HHP-18	Bridge Pin $\frac{1}{8}$	3
2	HCP-58-175	Clevis Pin $\frac{5}{8}$ - $1\frac{3}{4}$	1
3	10-135	Hydraulic Cylinder	1
	HNJ-58-18	Jam Nut $\frac{5}{8}$ - 18	1
	8-154	Rod End	1
	HG-14-28-180	Grease Fitting $\frac{1}{4}$ - 28 x 180°	1
4	18-214	45° Elbow	1
5	18-169	$\frac{3}{8}$ Adapter	1
6	HB-12-13-500	Bolt $\frac{1}{2}$ - 13 x 5	4
	HNFL-12-13	Flange Lock Nut $\frac{1}{2}$ - 13	4
7	HCP-12-300	Clevis Pin $\frac{1}{2}$ - 3	1
	HP-18-100	Cotter Pin $\frac{1}{8}$ x 1	1
8	42-015	Attachment Mount	2
9	43-150	Hydraulic Cylinder	1
10	18-168	90° Elbow	2
11	34-220	Pivot Bracket - RH	1
12	43-138	Lift Linkage	1
13	HCP-34-200	Clevis Pin $\frac{3}{4}$ x 2	1
14	HB-38-24-100	Bolt $\frac{3}{8}$ - 24 x1	2
15	HSSHB-12-13-200	Button Socket Head Cap Screw	2
	HN-12-13	Nut $\frac{1}{2}$ -13	2
	HNCL-12-13	Center Lock Nut $\frac{1}{2}$ - 13	2
16	43-137	Lift Bar	1
	15-019	rubber Grip	2
17	43-141	Lift Arm	1
18	HCP-12-450	Clevis Pin $\frac{1}{2}$ - $4\frac{1}{2}$	1
19	34-219	Pivot Bracket - LH	1
20	43-139	Lock	1
21	43-136	Torsion Spring	1
22	HCP-78-350	Clevis Pin $\frac{7}{8}$ x $3\frac{1}{2}$	1
23	43-140	Frame Mount	1

# 13-729 2-BANK HYDRAULIC VALVE DRAWING

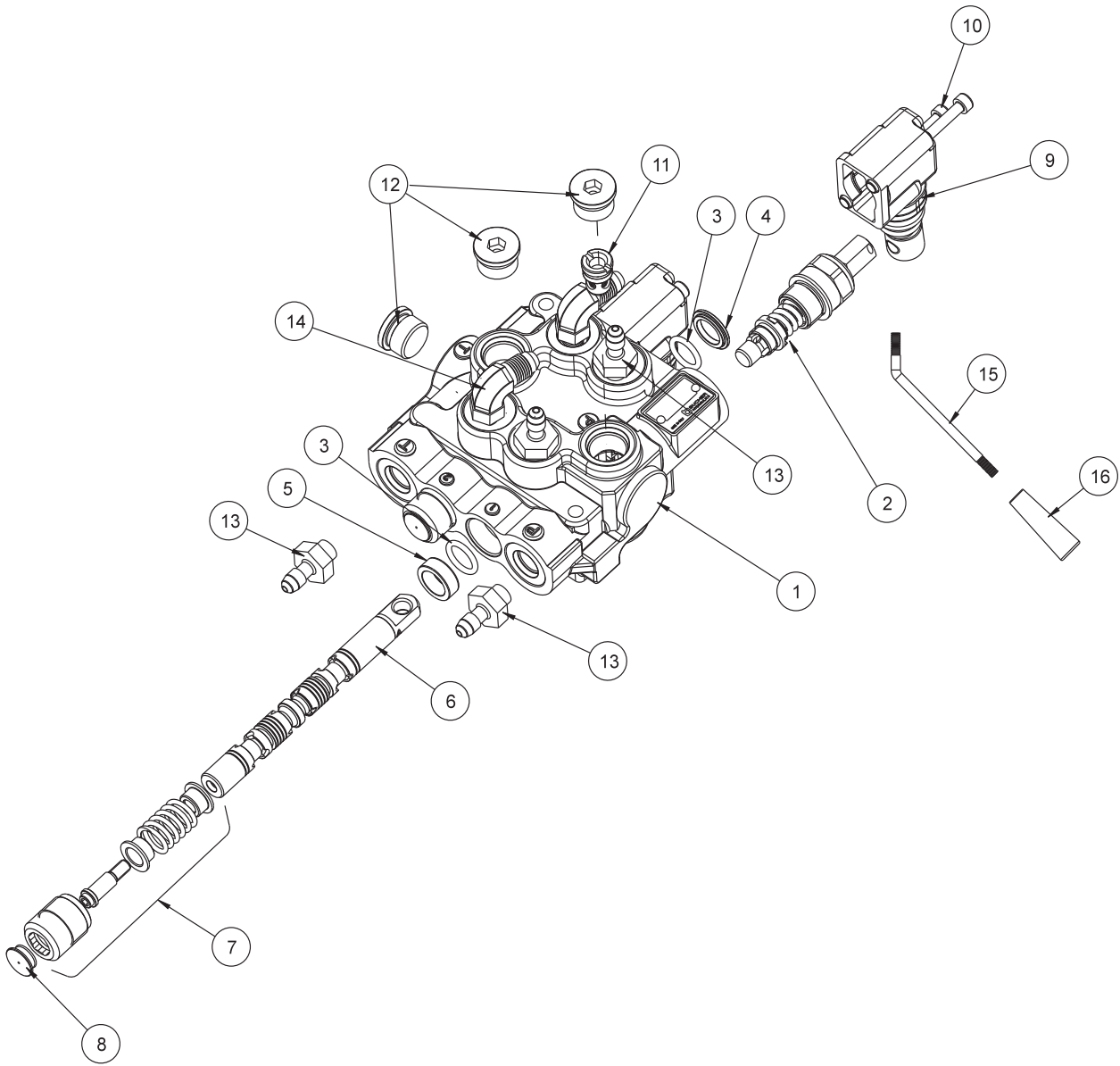

Parts

## 13-729 2-BANK HYDRAULIC VALVE PARTSLIST

REF #	PART #	DESCRIPTION	QUANTITY
1*	78-415-01	Body (complete with spacer and check valve)	1
2*	78-415-02	Spool HDM10	1
3*	78-415-03	O-Ring Seal	6
4*	78-415-04	Flanged Washer HDM10	3
5*	78-415-05	Spacer	3
6*	78-415-06	A Type Spool HDS11	3
7*	78-415-11	Positioner	2
8*	78-415-08	Plug	3
9*	78-415-09	Lever Group HDS11	3
10*	78-415-10	Metric Socket Screw M5 x .8 x 45	6
11*	78-415-12	Check Valve Assembly HDM12	1
12*	78-415-13	$\frac{3}{4}$ - 16 SAE 8 Screw Plug	3
13	18-166	Adapter $\frac{1}{4}$ - $\frac{3}{8}$ SAE	4
14	18-168	Elbow $\frac{3}{8}$ Straight Thread	2
15	78-418	Bent Handle	2
16		Tapered Knob	3
* 13-729		2 – Bank Hydraulic Valve (includes all * items)	

# 42-039 FRONT WHEEL MOTOR (4.0 C.I.) DRAWING

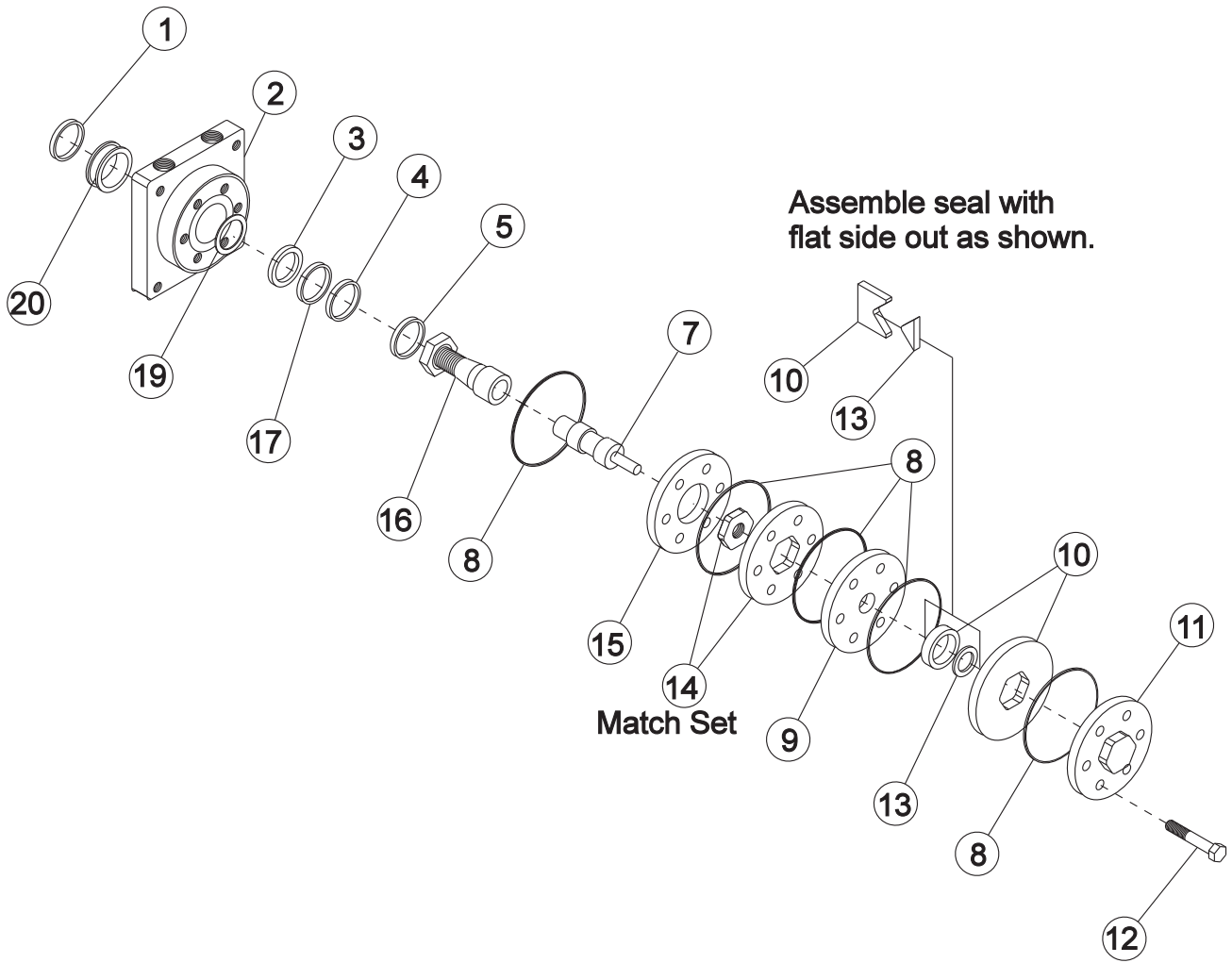

## 42-039 FRONT WHEEL MOTOR (4.0 C.I.) PARTSLIST

REF #	PART #	DESCRIPTION	QUANTITY
1*		Water & Dirt Seal	1
2	42-002-01	Service Housing Assembly	1
4	42-002-02	Thrust Bearing	1
5	42-002-03	Inner Bearing	1
7	42-039-01	Drive Link	1
8*		Ring Seal	5
9	42-002-05	Manifold	1
10	42-002-06	Commutator Assembly (matched set)	1
11	42-002-07	End Cap	1
12	42-039-02	Bolt	5
13*		Commutator Seal (matches with #10)	1
14	42-039-03	Rotor Set (matched set)	1
15	42-002-10	Wear Plate	1
16	42-002-11	Coupling Shaft	1
	HWK-14-100	Woodruff Key 1/4 x 1	1
	42-002-12	Nut 3/4 - 16	1
17	42-002-13	Thrust Washer	1
19*		Backup Ring	1
20	42-002-14	Outer Bearing	1
*	42-002-15	Seal Kit	1

# 42-002 REAR WHEEL MOTOR (8.0 C.I.) DRAWING

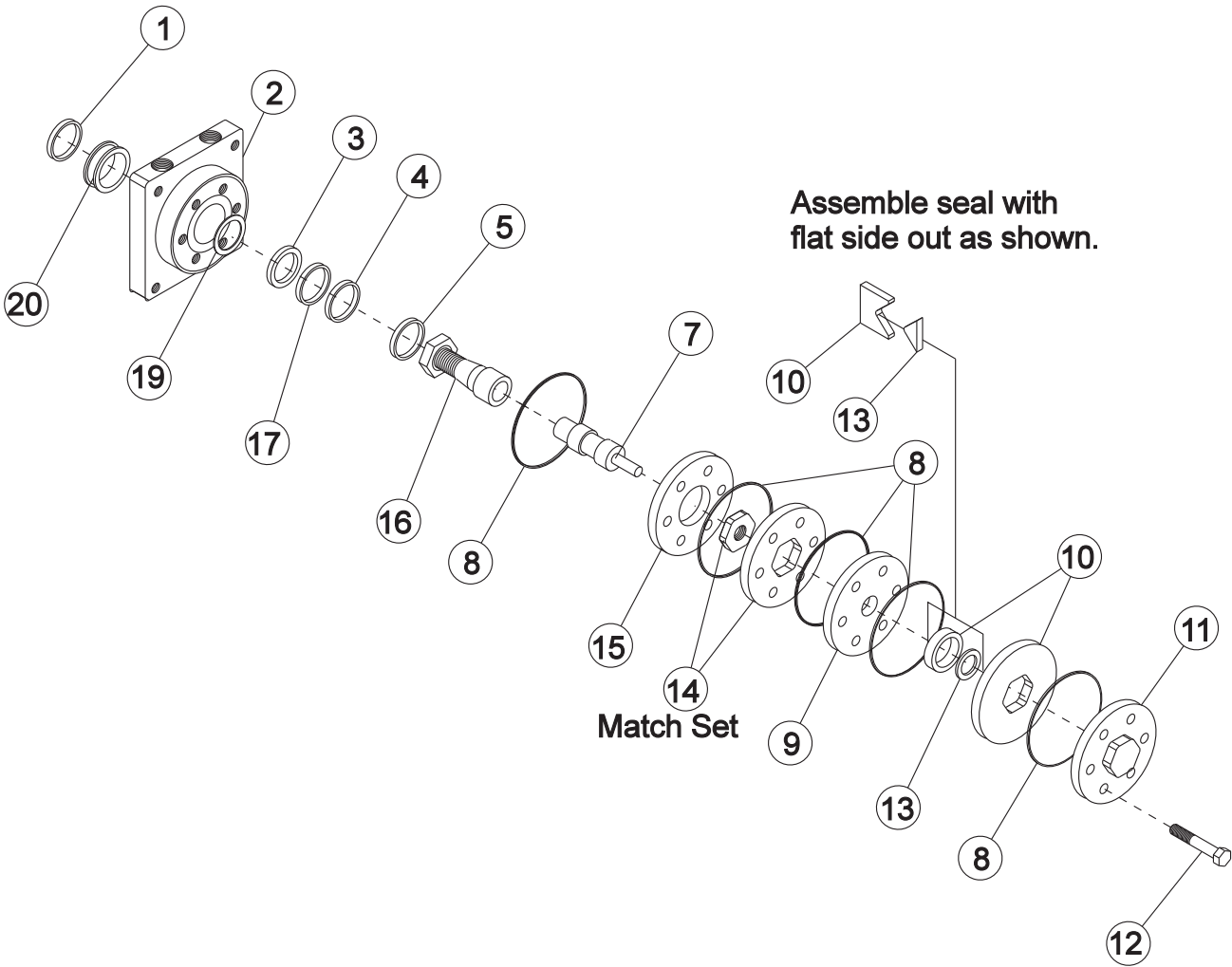

## 42-002 REAR WHEEL MOTOR (8.0 C.I.) PARTSLIST

REF #	PART #	DESCRIPTION	QUANTITY
1*		Water & Dirt Seal	1
2	42-002-01	Service Housing Assembly	1
4	42-002-02	Thrust Bearing	1
5	42-002-03	Inner Bearing	1
7	42-002-04	Drive Link	1
8*		Ring Seal	5
9	42-002-05	Manifold	1
10	42-002-06	Commutator Assembly (matched set)	1
11	42-002-07	End Cap	1
12	42-002-08	Bolt	5
13*		Commutator Seal (matches with #10)	1
14	42-002-09	Rotor Set (matched set)	1
15	42-002-10	Wear Plate	1
16	42-002-11	Coupling Shaft	1
	HWK-14-100	Woodruff Key 1/4 x 1	1
	42-002-12	Nut 3/4 - 16	1
17	42-002-13	Thrust Washer	1
19*		Backup Ring	1
20	42-002-14	Outer Bearing	1
*	42-002-15	Seal Kit	1

# 42-302 ELECTRIC ON - OFF VALVE DRAWING

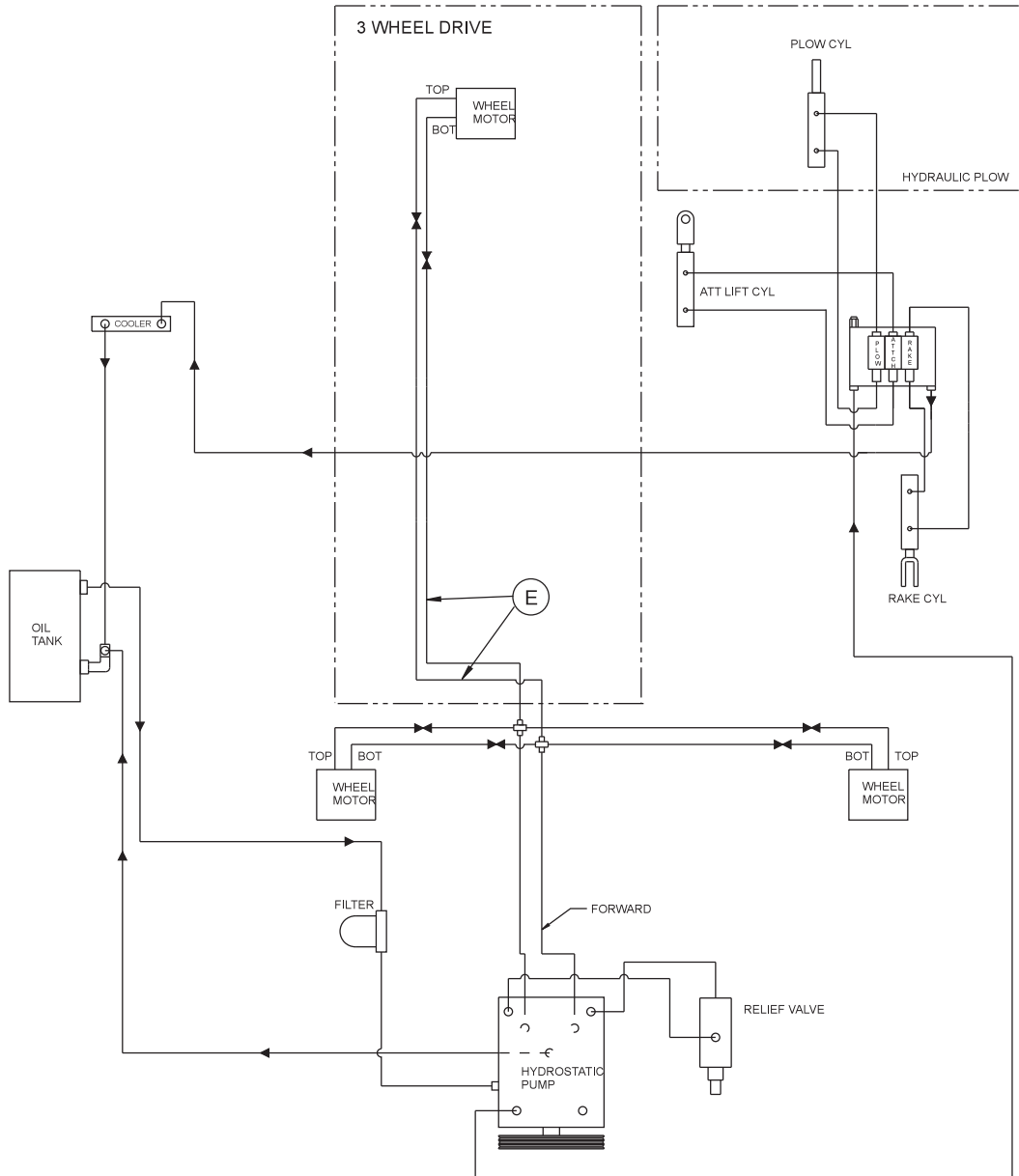
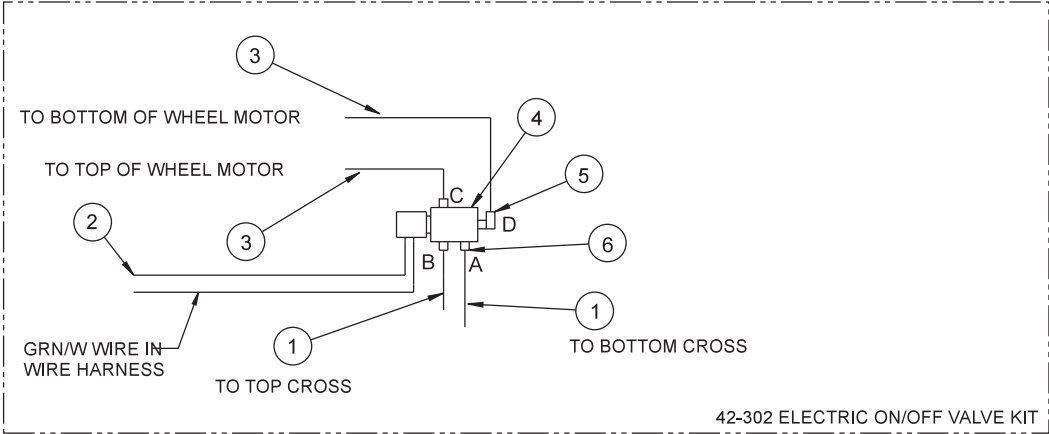

Parts



## 42-302 ELECTRIC ON - OFF VALVE PARTS LIST

REF #	PART #	DESCRIPTION	QUANTITY
1	42-263	Hydraulic Hose	2
2	76-260	Wire, Ground	1
3	42-264	Hydraulic Hose	2
4	42-118	Electric On/Off Valve	1
	HB-14-20-200	Bolt 1/4 - 20 x 2	2
	HNFL-14-20	Flange Whiz Lock Nut 1/4 - 20	2
5	18-185	Elbow 90°	1
6	18-341	Elbow 45°	3

## INSTALLATION INSTRUCTIONS

1. Shut off machine and let engine cool. Remove key, disconnect negative (-) battery cable and pull spark plug wires..
2. Assemble the fittings into the electric on/off valve. With valve lying on bench with solenoid to the left, install the three 45° elbows (Ref 6) in the two ports closest to you and one port furthest from you. Install the one 90° elbow (Ref 5) in the right hand port.
3. Install two 42-264 hydraulic hoses (Ref 3) on C and D. Tighten.
4. Install two 42-263 hydraulic hoses (Ref 1) on A and B. Be sure straight end of hose is on the valve with the fitting going backward. Tighten.
5. Remove mud guard and place a drain pan under the cross fittings that the hoses from the front wheel motor go to.
6. Disconnect the two hoses going to the front wheel motor at the cross, then at the front wheel motor and remove.
7. Remove the cover plate from the fiber glass.
8. Feed two 42-264 hydraulic hoses (Ref 3) up through bearing plate, through the 3" hole, and out to the front fork. Connect to the front wheel motor with the hose from D to the bottom of the wheel motor and C to the top.
9. Bolt valve to bearing plate with solenoid to your left side. Use the 1/4 -20 x 2 bolt and flange whiz lock nut. Be sure to fasten the ground wire on one of the mounting bolts and the other end on one terminal of the solenoid valve.
10. Connect the two 42-263 hydraulic hoses (Ref 1) from the valve to the cross with the hose from A to the bottom cross and B to the top cross.
11. Install toggle switch on control panel. Uncoil green and white stripe wire from frame and hook on end to the toggle switch and the other end to the terminal on electric on/off valve. Install the loose end of the blue/white wire to the toggle switch.
12. Route hose and secure with 22-069 nylon ties. Reinstall mud guard.
13. Reconnect the negative (-) ground battery cable to battery and spark plug wires.
14. Make sure that everything is clear of the machine. Start the machine, test on/off valve for proper operation.
15. Check for hydraulic leaks.
16. Shut off machine, double check all fastener and fittings, be sure they are tight.
17. Reinstall cover plate.
18. Check hydraulic fluid, level should be 2 to 2 1/2 inches below the top of the tank when cold. Add if necessary.

# 42-302 ELECTRIC ON - OFF VALVE WIRING

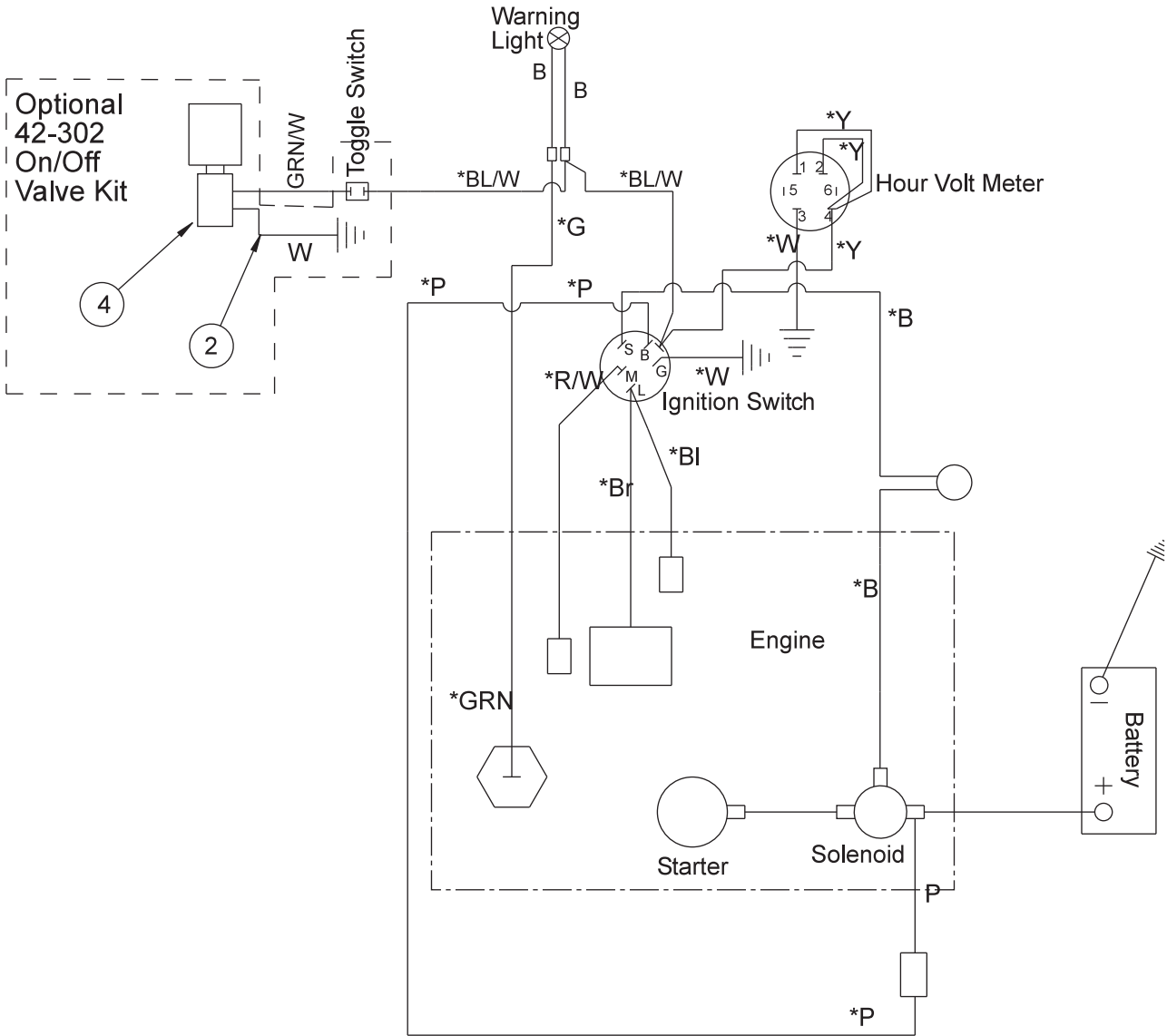

Parts

## 42-302 ELECTRIC ON - OFF VALVE PARTS LIST

REF #	PART #	DESCRIPTION	QUANTITY
1	42-263	Hydraulic Hose	2
2	76-260	Wire, Ground	1
3	42-264	Hydraulic Hose	2
4	42-118	Electric On/Off Valve	1
	HB-14-20-200	Bolt 1/4 - 20 x 2	2
	HNFL-14-20	Flange Whiz Lock Nut 1/4 - 20	2
5	18-185	Elbow 90°	1
6	18-341	Elbow 45°	3

## INSTALLATION INSTRUCTIONS

1. Shut off machine and let engine cool. Remove key, disconnect negative (-) battery cable and pull spark plug wires..
2. Assemble the fittings into the electric on/off valve. With valve lying on bench with solenoid to the left, install the three 45° elbows (Ref 6) in the two ports closest to you and one port furthest from you. Install the one 90° elbow (Ref 5) in the right hand port.
3. Install two 42-264 hydraulic hoses (Ref 3) on C and D. Tighten.
4. Install two 42-263 hydraulic hoses (Ref 1) on A and B. Be sure straight end of hose is on the valve with the fitting going backward. Tighten.
5. Remove mud guard and place a drain pan under the cross fittings that the hoses from the front wheel motor go to.
6. Disconnect the two hoses going to the front wheel motor at the cross, then at the front wheel motor and remove.
7. Remove the cover plate from the fiber glass.
8. Feed two 42-264 hydraulic hoses (Ref 3) up through bearing plate, through the 3" hole, and out to the front fork. Connect to the front wheel motor with the hose from D to the bottom of the wheel motor and C to the top.
9. Bolt valve to bearing plate with solenoid to your left side. Use the 1/4-20 x 2 bolt and flange whiz lock nut. Be sure to fasten the ground wire on one of the mounting bolts and the other end on one terminal of the solenoid valve.
10. Connect the two 42-263 hydraulic hoses (Ref 1) from the valve to the cross with the hose from A to the bottom cross and B to the top cross.
11. Install toggle switch on control panel. Uncoil green and white stripe wire from frame and hook on end to the toggle switch and the other end to the terminal on electric on/off valve. Install the loose end of the blue/white wire to the toggle switch.
12. Route hose and secure with 22-069 nylon ties. Reinstall mud guard.
13. Reconnect the negative (-) ground battery cable to battery and spark plug wires.
14. Make sure that everything is clear of the machine. Start the machine, test on/off valve for proper operation.
15. Check for hydraulic leaks.
16. Shut off machine, double check all fastener and fittings, be sure they are tight.
17. Reinstall cover plate.
18. Check hydraulic fluid, level should be 2 to 2 1/2 inches below the top of the tank when cold. Add if necessary.



## DECAL LIST

***This is a list of decals located on the Super Star. Part number, description and location will help in reordering decals.***

13-556	Decal, Warning	1	Left Side Below Seat
25-277	Decal, Battery	1	Bottom Seat
25-286	Decal, Pinch Point	1	Bottom Seat Panel
25-298	Decal, Warning Hot	2	Bottom Seat Panel. Oil Filter Bracket
25-333	Decal, Emissions	1	Engine
25-337	Decal, Speed Boss	1	Hang from Steering
25-373	Decal, Smithco Star	1	Nose Cone
25-349	Decal, Foot Pedal	1	Right Side Nose Cone
25-352	Decal, By-Pass Valve	1	Hang Tag
25-354	Decal, Tire Pressure 5psi	3	Wheels
25-372	Decal, Smithco	1	Rear
25-361	Decal, Technical Assistance	1	Main Frame
27-077	Decal, Smithco Round	1	Steering Cap
43-110	Decal, Super Star	2	Nose Cone
42-765	Decal, Lift Control	1	Right Body Top
42-764	Decal, Control Panel	1	Left of Seat

## OPTIONAL EQUIPMENT

42-011	Front Mounted Manual Plow	42-026	Stainless Steel Tournament Rake 84"
43-003	Hydraulic Sand Plow	42-128	Stainless Steel Tournament Rake 72"
42-136	Front Mounted 60" Manual Plow	42-130	Mild Steel Tournament Rake 84"
42-460	40" Adjustable Angle Plow	42-132	Mild Steel Tournament Rake 72"
42-490	60" Adjustable Angle Plow	42-391	72" Multi Brush Rake
43-130	Weed Cultivator	42-392	84" Multi Brush Rake
42-008	Sand Cultivator	13-438	Rake Assembly with Finishing Blades
42-340	Sand Cultivator w/ Spring Tine	13-684	Brush Kit (for 13-438)
42-341	Sand Cultivator w/ Castor Wheels	13-740	Brush Attachment - 84"
42-285	Scarifier w/ Vertical Blades	42-223	Edger Kit
42-010	Construction Leveling Blade	43-004	Grader Blade Kit
26-007	Professional Infield Finisher	42-794	Ball Mount Kit
26-008	Flex Action Field Finisher	42-750	Razor Edger Kit
43-043	Brush Kit (for 26-008)	13-319	Fan Rake Kit
43-002	Flex Action Field Finisher with Brush	13-298	Fan Rake Attachment
43-088	Drag Mat Kit	42-188	Drag Mat
42-315	Light Kit	42-800	ROPS
34-191	Box Grader		
42-178	Infield Scarifier (w/ Straight Blades & Castor Wheels)		
42-179	Infield Scarifier (w/ Chisel Blades & Castor Wheels)		
42-581	Green Star Roller Set (needs 42-586 main frame)		
42-582	Green Star Spiker Set (needs 42-586 main frame)		
42-585	Green Star Brush Set (needs 42-586 main frame)		
42-586	Green Star Main Frame		
42-550	Greens Star Roller, Brush, Spiker System with Main Frame		

## QUICK REFERENCE REPLACEMENT PARTS

### REPLACEMENT FILTERS

23-031	Hydraulic Oil Filter	
15-165-01	Air Filter Element with Pre-Cleaner	Briggs and Stratton# 5050
42-076-03	Air Filter Element Fender Mounted	
50-403	Fuel Filter	
13-531	Engine Oil Filter	Briggs and Stratton# 492932

### SEAL KITS

42-002 and 42-039	Wheel Motors	
42-002-15	Seal Kit	
42-220	2-Bank Hydraulic Valve	
14-062	Seal Kit	
14-106	Relief Assembly Kit	
14-203	Spring Centering Assembly Kit (1 per bank)	
42-227	3-Bank Hydraulic Valve	
14-205	Seal Kit	
14-106	Relief Assembly Kit	
14-203	Spring Centered Assembly Kit (1 per bank)	
10-135	Hydraulic Cylinder (Attachment Lift Cylinder)	
13-357	Hydraulic Cylinder for Rake Lift	
13-292	Hydraulic Cylinder for Sand Plow Lift	
14-267	Seal Kit	

### FLUIDS

Engine Oil	Refer to Engine Manual	
Hydraulic Fluid	SAE 10W-40 API Service SJ or higher Motor Oil	

### OTHER PARTS

Spark Plugs	RC12YC (Gap 0.030 inch (0.76mm))
-------------	----------------------------------

# ACCESSORIES

<b>Plows</b> .....	<b>A</b>
<b>13-731 Single Bank Valve</b> .....	<b>2</b>
<b>43-003 Hydraulic Sand Plow</b> .....	<b>4</b>
<b>42-011 Sand Plow(Steel &amp; Aluminum)</b> .....	<b>8</b>
<b>42-136 60" Sand Plow</b> .....	<b>10</b>
<b>42-460 40" Angle Plow</b> .....	<b>12</b>
<b>42-490 60" Angle Plow</b> .....	<b>14</b>
<b>42-315 Light Kit</b> .....	<b>16</b>
<b>Belly Attachments</b> .....	<b>B</b>
<b>42-223 Adjustable Disc Edger</b> .....	<b>2</b>
<b>42-750 Cart Path &amp; Sidewalk Edger</b> .....	<b>4</b>
<b>42-130 Wedd Cultivator</b> .....	<b>6</b>
<b>42-008 Sand Cultivator</b> .....	<b>8</b>
<b>42-340 Sand Cultivator w/ Spring Tine</b> .....	<b>10</b>
<b>42-341 Sand Cultivatore w/ Castor Wheels</b> .....	<b>12</b>
<b>42-010 Construction Leveling Blade</b> .....	<b>14</b>
<b>42-210 Grader Blade Kit</b> .....	<b>16</b>
<b>42-178 Infield Scarifier(vertical blades)</b> .....	<b>18</b>
<b>42-179 Infield Scarifier(chisel blades)</b> .....	<b>22</b>
<b>42-285 Scarifier w/ Vertical Blades</b> .....	<b>26</b>
<b>Rear Attachments</b> .....	<b>C</b>
<b>42-391Q 72" Pro-Brush Tournament Rake</b> .....	<b>2</b>
<b>43-392Q 84" Pro-Brush Tournament Rake</b> .....	<b>6</b>
<b>42-130Q 84" Mild Steel Rake</b> .....	<b>10</b>
<b>42-132Q 72" Mild Steel Rake</b> .....	<b>14</b>
<b>13-438Q Rake with Finishing Blades</b> .....	<b>18</b>
<b>13-298Q Fan Rake</b> .....	<b>20</b>
<b>26-007Q Professional Field Finisher</b> .....	<b>22</b>
<b>42-185 Drag Mat Kit</b> .....	<b>22</b>
<b>43-002Q Flex Action Field Finisher w/ Brush</b> .....	<b>24</b>
<b>26-008Q Flex Action Field Finisher</b> .....	<b>28</b>
<b>42-586Q Green Star RBS Main Frame</b> .....	<b>30</b>
<b>42-581 Green Star RBS Roller</b> .....	<b>32</b>
<b>42-585 Green Star RBS Brush</b> .....	<b>34</b>
<b>42-582 Green Star RBS Spiker</b> .....	<b>36</b>
<b>Warranty</b> .....	<b>Inside Back Cover</b>

Front Attachment

Center Attachment

Rear Attachment

# 13-731 SINGLE BANK HYDRAULIC VALVE DRAWING

Front Attachment

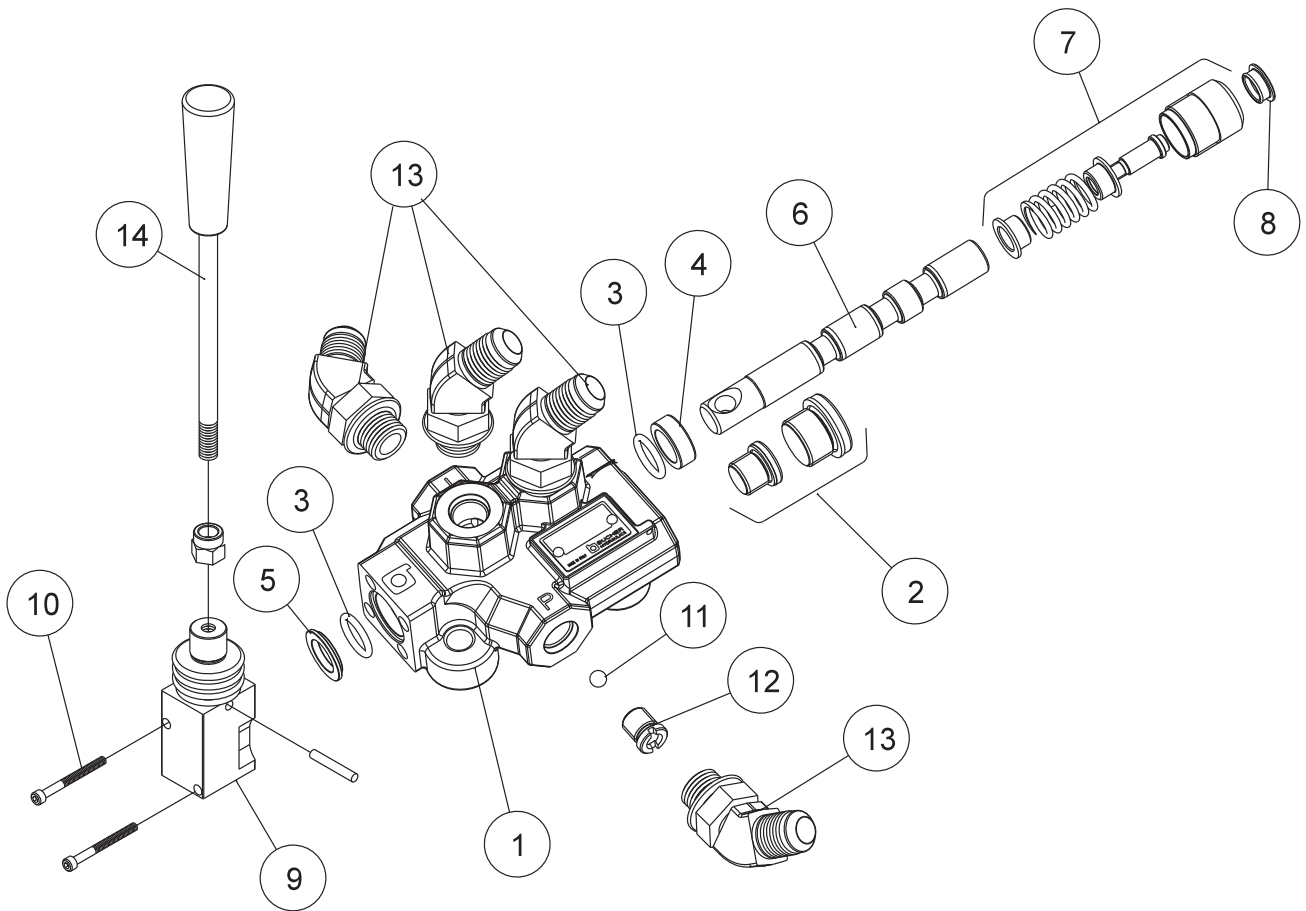



## 13-731 SINGLE BANK HYDRAULIC VALVE PARTS LIST

REF #	PART #	DESCRIPTION	QUANTITY
1*	13-731-01	Actuator Housing Assembly	1
2*	13-731-02	Valve Plug	1
3*†	78-415-03	O-Ring Seal	2
4*†	78-415-05	Spacer	3
5*	78-415-04	Flanged Washer HDM10	3
6*	13-731-03	Spool	1
7*	78-415-11	Positioner	1
8*	78-415-08	Plug	3
9*	78-415-09	Lever Group HDS11	3
10*	78-415-10	Metric Socket Screw M5 x .8 x 45	2
11*	13-731-04	1/4" Ball	1
12*†	13-731-05	Check Valve	1
13	18-188	45° ELbow	4
14	78-417	Straight Handle	1
* †	13-731 13-731-01	Single Bank Hydraulic Valve (includes all * items) Actuator Housing Assembly	1 per Bank

# 43-003 HYDRAULIC SAND PLOW DRAWING

Front Attachment

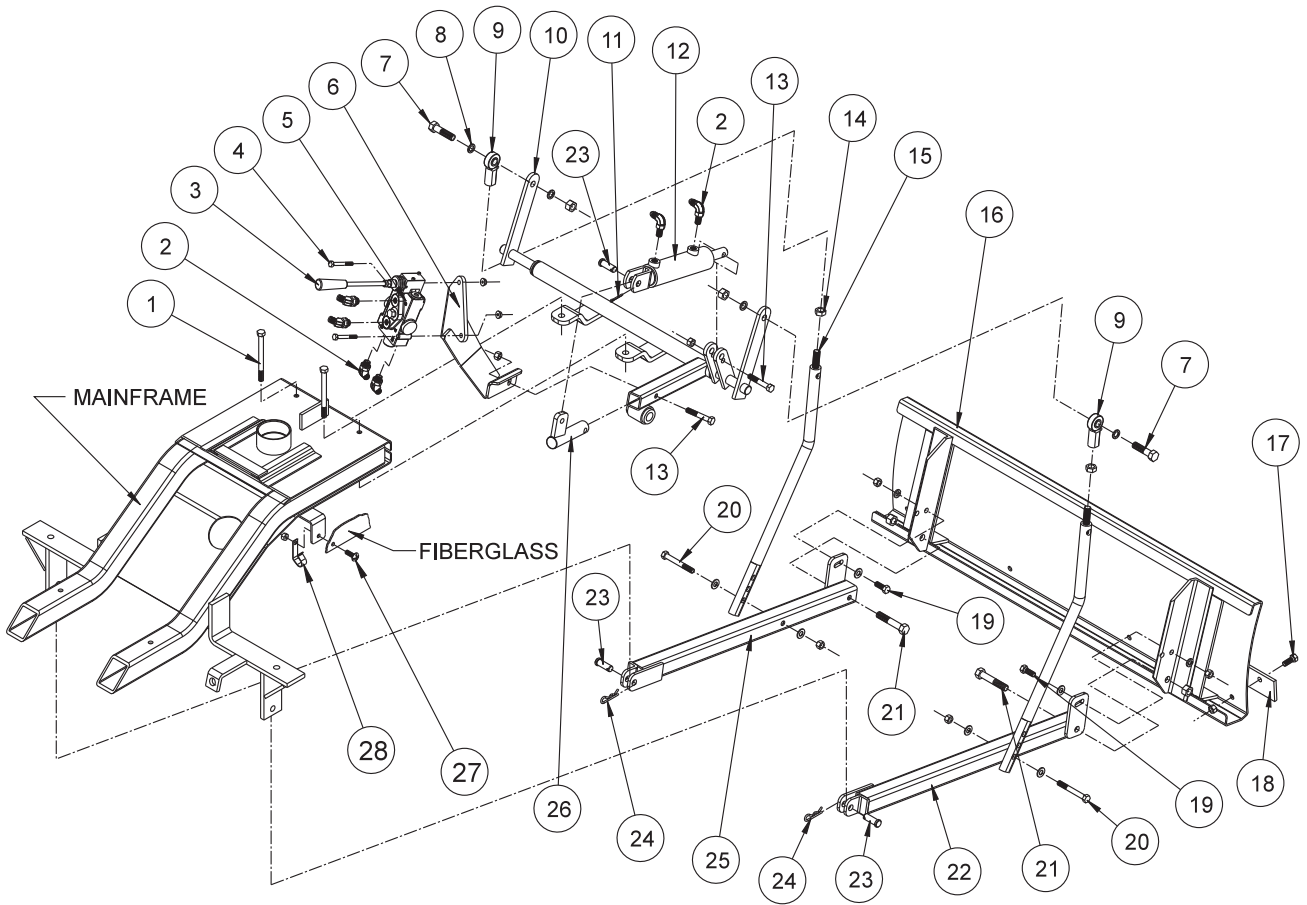

# HYDRAULIC VALVE PLUMBING DRAWING

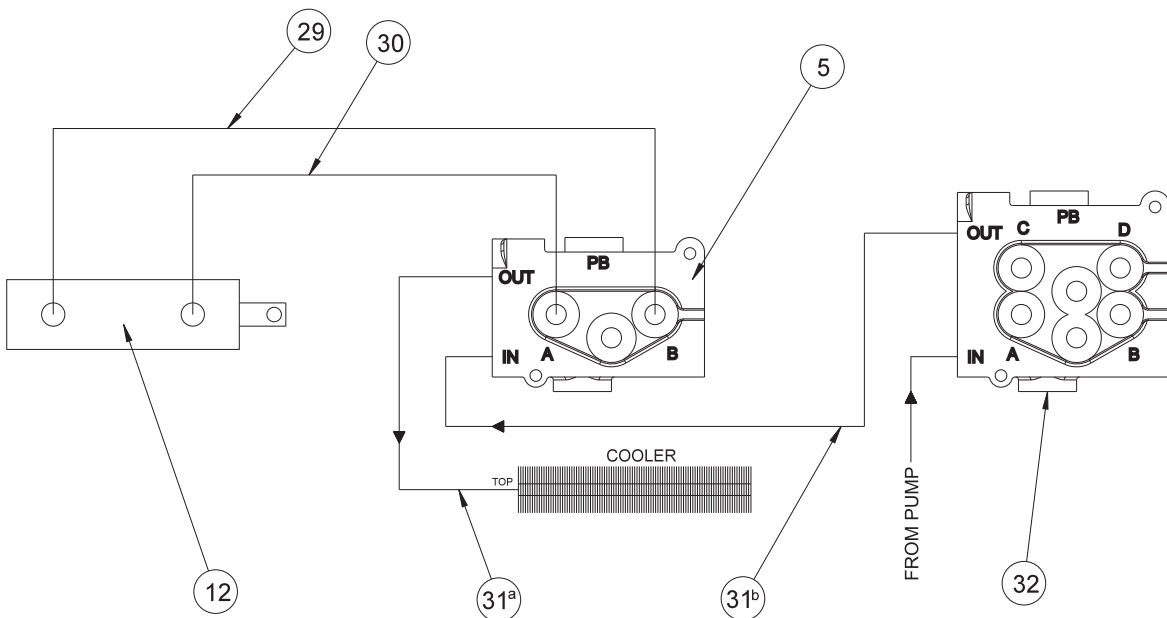

## 43-003 HYDRAULIC SAND PLOW PARTS LIST

REF#	PART#	DESCRIPTION	QUANTITY
1	HB-38-16-350	Bolt, $\frac{3}{8}$ - 16 x $3\frac{1}{2}$ (Part of machine)	2
	HW-38	Washer, $\frac{3}{8}$	2
	HNTL-38-16	Lock Nut, $\frac{3}{8}$ - 16	2
2	18-188	45° Elbow	6
3	42-225	Straight Handle Kit	1
4	HB-14-20-200	Bolt, $\frac{1}{4}$ - 20x 2	2
	HNFL-14-20	Flange Whiz-Lock Nut, $\frac{1}{4}$ - 20	2
5	43-046	Single Bank Hydraulic Valve	1
6	43-050	Valve Mount	1
7	HB-12-13-200	Bolt, $\frac{1}{2}$ - 13 x 2	2
	HNTL-12-13	Lock Nut, $\frac{1}{2}$ - 13	2
8	HMB-12-14	Machine Bushing, $\frac{1}{2}$ x 14GA	4
9	80-006	Rod End	2
10	42-346	Lift Assembly	1
11	HP-18-100	Cotter Pin, $\frac{1}{8}$ x 1	1
12	13-292	Hydraulic Cylinder	1
13	HB-38-16-200	Bolt, $\frac{3}{8}$ - 16 x 2	2
	HNTL-38-16	Lock Nut, $\frac{3}{8}$ - 16	2
14	HNJ-12-20	Jam Nut, $\frac{1}{2}$ - 20	2
15	27-073	Lift Rod	2
16	27-017	Aluminum Sand Plow Blade	1
17	HB-38-16-100	Bolt, $\frac{3}{8}$ - 16 x 1	4
	HNFL-38-16	Flange Whiz Lock Nut, $\frac{3}{8}$ - 16	4
18	13-167	Wear Blade	1
19	HB-38-16-100	Bolt, $\frac{3}{8}$ - 16 x 1	2
	HW-38	Washer, $\frac{3}{8}$	2
	HWL-38	Lockwasher, $\frac{3}{8}$	2
	HN-38-16	Nut, $\frac{3}{8}$ - 16	2
20	HB-38-16-300	Bolt, $\frac{3}{8}$ - 16 x 3	2
	HW-38	Washer, $\frac{3}{8}$	4
	HNTL-38-16	Lock Nut, $\frac{3}{8}$ - 16	2
21	HB-12-13-300	Bolt, $\frac{1}{2}$ - 13 x 3	2
	HNTL-12-13	Lock Nut, $\frac{1}{2}$ - 13	2
22	27-050	Right Pusher Bar	1
23	HCP-12-150	Clevis Pin, $\frac{1}{2}$ x $1\frac{1}{2}$	3
24	HHP-18	Bridge Pin, $\frac{1}{8}$	2
25	27-049	Left Pusher Bar	1
26	42-096	Cylinder Lift	1
27	HSTP-516-18-100	Machine Screw, $\frac{5}{16}$ - 18 x 1 (on machine)	1
28	HLC-A-58	Loom Clamp	1
29	43-049	Hose, 18"	1
30	43-048	Hose, 20"	1
31 <sup>a&amp;b</sup>	43-047	Hose, 57 $\frac{1}{2}$ "	2
32	42-220	2-Bank Valve (on machine)	

# 43-003 HYDRAULIC SAND PLOW DRAWING

Front Attachment

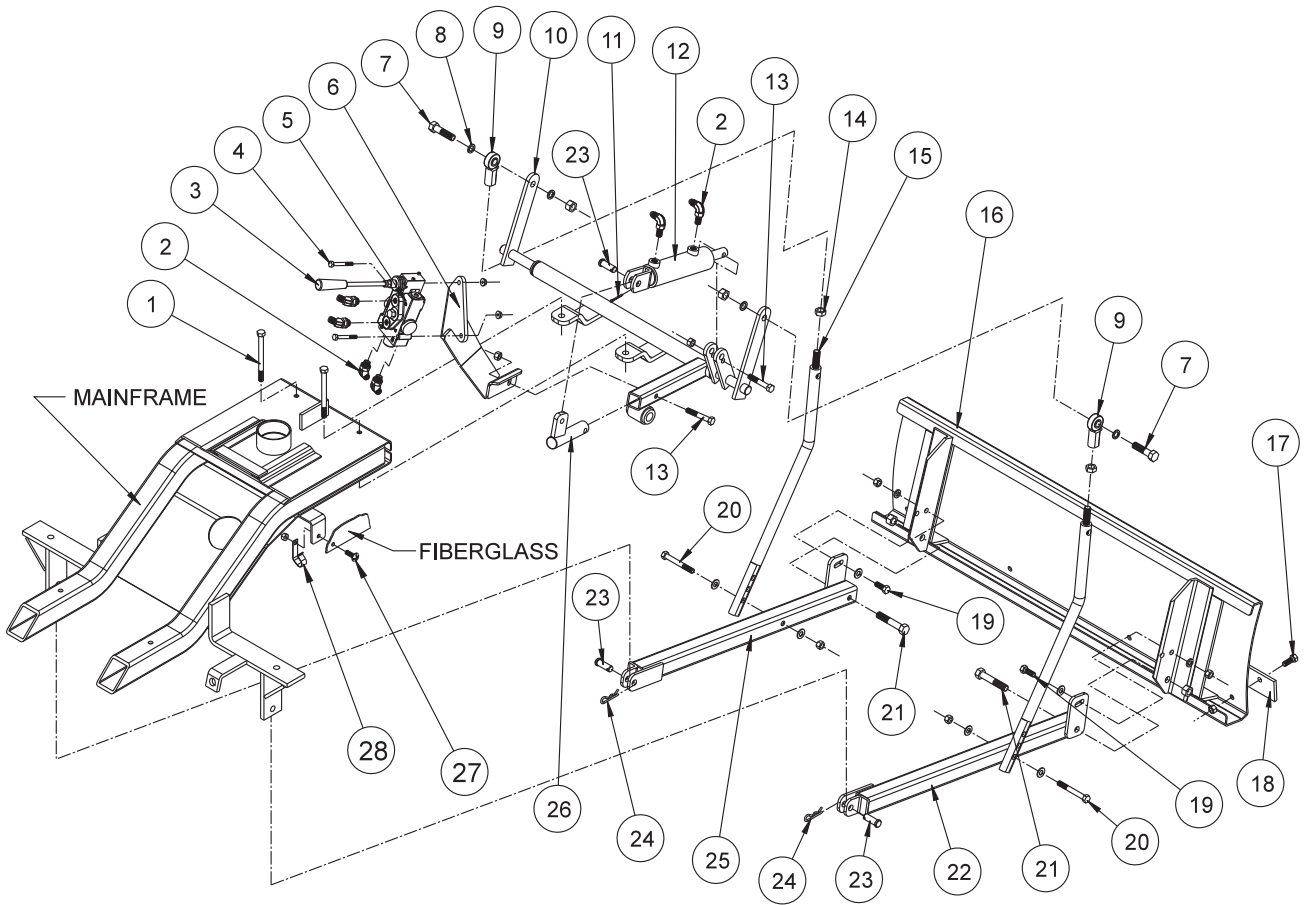

# HYDRAULIC VALVE PLUMBING DRAWING

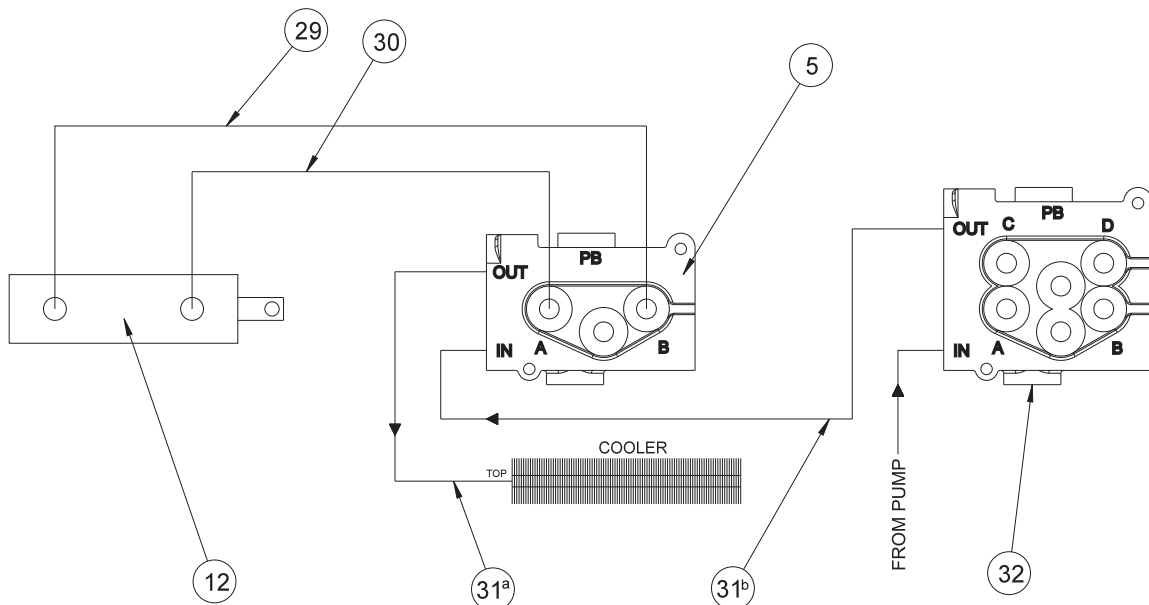

## 43-003 HYDRAULIC SAND PLOW INSTRUCTIONS

1. Assemble Pusher Bars (Ref # 22 and 25) to Plow Blade (Ref # 16) using one  $\frac{3}{8}$ -16 x 1 Bolt (Ref # 19) and one  $\frac{3}{8}$ -16 x 3 Bolt (Ref #21) per Pusher Bar. There are 2 holes to bolt (Ref # 19) hardware in. Using hole closest to the blade will result in a shallow cut, whereas using the hole furthest from the blade will result in a deeper cut. The slot on the pusher bar is for a more fine tuned adjustment.
2. Assemble the Lift Assembly (Ref # 10) to the Main Frame using the two studs that are under the frame and below the front of the console.
3. Place Cylinder Lift (Ref # 26) into the tube on Lift Assembly (Ref # 10) with the tab pointing up hold with a  $\frac{3}{8}$ -16 x 2 Bolt (Ref # 13), assemble the Valve Mount (Ref # 6) onto this bolt on the outside of the tube and secure both with one  $\frac{3}{8}$ -16 Nut. Using a  $\frac{3}{8}$ -16 x 2 Bolt mount the Hydraulic Cylinder (Ref # 12) to the Lift Assembly and secure with one  $\frac{3}{8}$ -16 Nut. Connect the other end of the Hydraulic Cylinder to the Cylinder Lift using  $\frac{1}{2}$  x  $1\frac{1}{2}$  Clevis Pin (Ref # 23) and  $\frac{1}{8}$  x 1 Cotter Pin (Ref #11).
4. Thread one  $\frac{1}{2}$  - 20 Jam Nut (Ref # 14) onto each Lift Rod (Ref # 15) followed by the Rod Ends (Ref # 9). Adjust to equal lengths. Bolt Lift Rods to Lift Arms on Lift Assembly (Ref # 10) with Rod Ends to the outside. Bolt from outside with the  $\frac{1}{2}$ " Machine Bushing (Ref # 8) between Rod End and Lift Arm and secure with  $\frac{1}{2}$  -13 Lock Nut.
5. Slide the Plow/Pusher Bar Assembly under machine and connect to machine. Secure using  $\frac{1}{2}$  x  $1\frac{1}{2}$  Clevis Pins (Ref # 23) and  $\frac{1}{8}$ " Bridge Pins (Ref # 24).
6. To connect Lift Rods (Ref # 15) to Pusher Bars start by lifting up the Plow Blade. Using one  $\frac{3}{8}$ -16 x 3 Bolt (Ref # 20) and two  $\frac{3}{8}$ " Washers assembly the Lift Rods to the Right (Ref #22) and Left (Ref # 25) Pusher Bars using the bottom hole in the Lift Rods as illustrated. Secure each with one  $\frac{3}{8}$ -16 Lock Nut.
7. To fine tune the height of the blade off ground; turn the Rod Ends (Ref # 9) on the Lift Rods (Ref # 15). Turning the Rod Ends counter-clockwise will increase down pressure. Turning them clockwise will decrease down pressure.
8. Thread four of the 45° Elbow fittings (Ref # 2) into the Single Bank Valve (Ref # 5), one each in the **A** port, **B** port, **IN** port and **OUT** port. Thread the remaining two 45° Elbow fittings into the ports on the Hydraulic Cylinder (Ref # 12). Make sure the fittings on the Hydraulic Cylinder are pointing towards the machine.
9. Connect the 57 $\frac{1}{2}$ " Hoses (Ref # 31) to the fittings on the Single Bank Hydraulic Valve (Ref #5). One to the **IN** port and one to the **OUT** port. Next connect the 18" Hose (Ref # 27) to the fitting in the **B** port and connect the 20" Hose (Ref # 28) to the fitting in the **A** port.
10. Mount the Single Bank Hydraulic Valve (Ref # 5) to the Valve Mount (Ref # 6) as illustrated using the two  $\frac{1}{4}$  - 20 x 2 Bolts (Ref # 4). Secure with the two  $\frac{1}{4}$  - 20 Flange Whiz-Lock Nuts. Connect the Straight Handle Kit (Ref # 3) to the Valve. Reference *Single Bank Hydraulic Valve Drawing* on page 6 for a detailed view of the Valve.
11. Route the 18" Hose (Ref # 29) from the **B** port on the Single Bank Hydraulic Valve (Ref # 5) to the rear port on the Hydraulic Cylinder. Route the 20" Hose (Ref # 30) from the **A** port on the Single Bank Hydraulic Valve to the front port on the Cylinder.
12. Disconnect the negative (-) ground battery cable from the battery. Place a drain pan under the valve on the machine. **ENGINE MUST BE COOL BEFORE DISCONNECTING THE HOSES.**
13. Disconnect the hose from the **OUT** port on the 2 Bank Valve (Ref # 32) and the **top** port on the Oil Cooler. Discard this hose, it will not be used. Connect the 57 $\frac{1}{2}$ " Hose (Ref # 31<sup>a</sup>) from the **OUT** port on the Single Bank Valve to the top port on the Oil Cooler. Connect the other 57 $\frac{1}{2}$ " Hose (Ref # 31<sup>b</sup>) from the **IN** port of the Single Bank Valve to the **OUT** port of the 2 Bank Valve. Tie up Hoses using  $\frac{5}{8}$  Loom Clamp (Ref # 28). Route 57 $\frac{1}{2}$ " Hoses under the body and along the frame avoiding any pinch points. Fasten to the frame using the 14 $\frac{1}{2}$ " Nylon Ties.
14. Reconnect the negative (-) ground battery cable to battery.
15. Make sure that everything is clear of the machine. Start the machine, work the valve so that the plow will both raise and lower. Also, do this with both the attachment lift and the rake lift. Work the lift a number of times until all air works out of the plow circuit and the cylinder works smoothly. At this time look for hydraulic leaks. If there are leaks, turn engine off and repair, start up and check again.
16. Check the hydraulic oil level. The level should be 2" to 2 $\frac{1}{2}$ " below the top of the tank. If more is needed, use SAE 10W-40 API service SG motor oil.

42-011 -AB ALUMINUM SAND PLOW DRAWING

42-011 -SB STEEL SAND PLOW DRAWING

Front Attachment

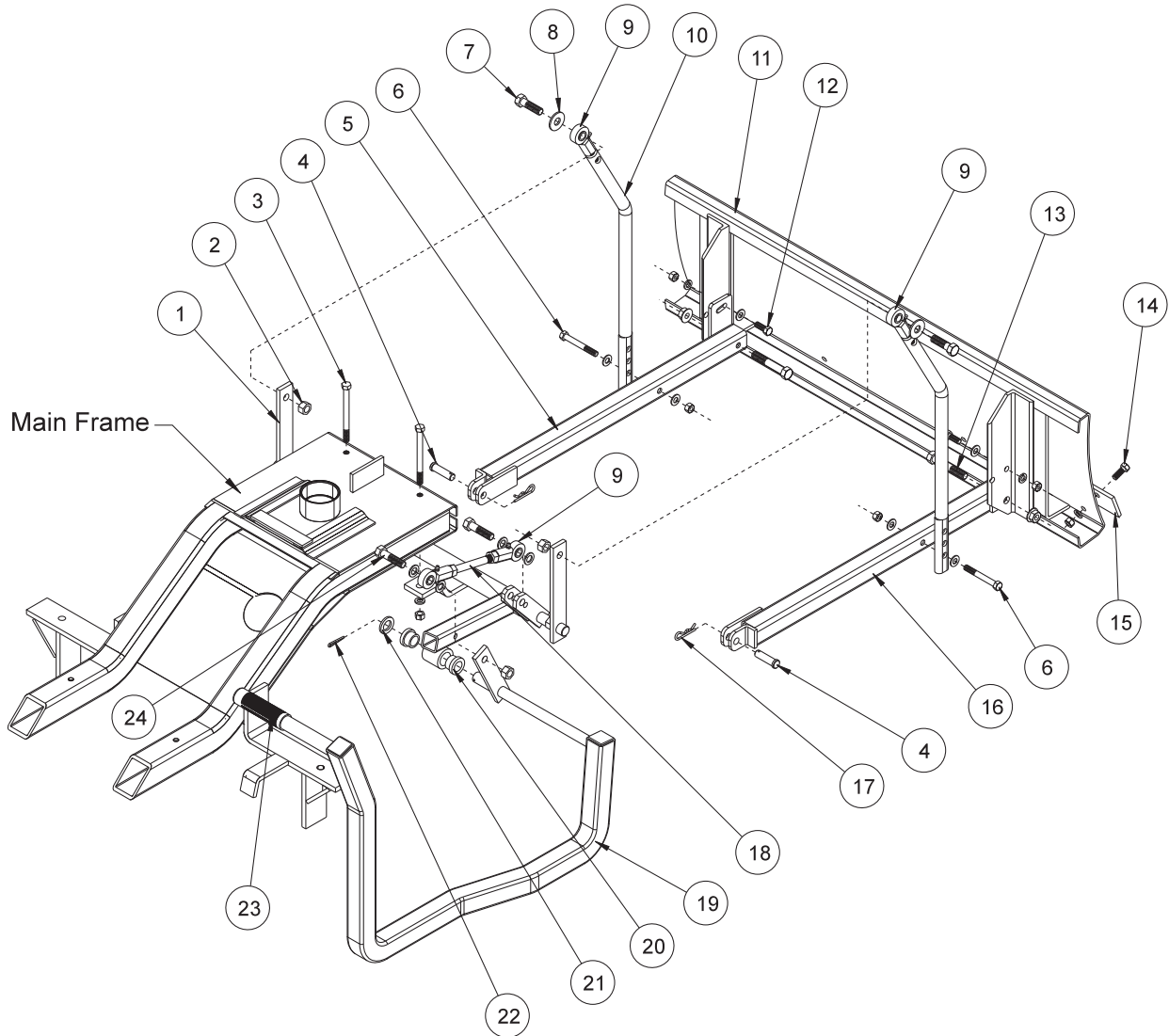

## 42-011 SAND PLOW PARTS LIST

REF#	PART#	DESCRIPTION	QUANTITY
1	42-346	Lift Assembly (includes Ref# 20)	1
2	HNTL-12-13	Lock Nut 1/2 - 13	2
3	HB-38-16-350	Bolt 3/8 - 16 x 3 1/2 (part of main frame)	2
	HWL-38	Lock Washer 3/8	2
	HN-38-16	Nut 3/8 - 16	2
4	HCP-12-150	Clevis Pin 1/2 x 1 1/2	2
5	27-049	Left Pusher Bar	1
6	HB-38-16-300	Bolt 3/8 - 16 x 3	2
	HW-38	Washer 3/8	4
	HNTL-38-16	Lock Nut 3/8 - 16	2
7	HB-12-13-200	Bolt 1/2 - 13 x 2	2
8	HMB-12-14	Machine Bushing 1/2 x 14GA	8
9	80-006	Rod End	4
	HNJ-12-20	Jam Nut 1/2 - 20	4
10	27-073	Lift Rod	2
11	27-017	Aluminum Sand Plow Blade	1
	13-352	Steel Sand Plow Blade	1
12	HB-38-16-100	Bolt 3/8 - 16 x 1	2
	HW-38	Washer 3/8	2
	HWL-38	Lock Washer 3/8	2
	HN-38-16	Nut 3/8 - 16	2
13	HB-12-13-300	Bolt 1/2 - 13 x 3	2
	HNTL-12-13	Lock Nut 1/2 - 13	2
14	HB-38-16-100	Bolt 3/8 - 16 x 1	4
	HNFL-38-16	Flange Whiz Lock Nut 3/8 - 16	4
15	13-167	Wear Blade	1
16	27-050	Right Pusher Bar	1
17	HHP-18	Bridge Pin 1/8	2
18	42-348	Rod	1
19	42-347	Lift Handle	1
20	18-221	Flange Bushing	2
21	HMB-34-14	Machine Bushing 3/4 - 14GA	1
22	HP-18-150	Cotter Pin 1/8 x 1 1/2	1
23	15-019	Grip	1
24	HB-12-13-200	Bolt 1/2 - 13 x 2	2

## INSTALLATION INSTRUCTIONS

- Assemble the pusher bars (Ref 5 and 16) to the plow (Ref 11) using hardware (Ref 12 & 13). There are 2 holes to bolt the hardware in. Using hole closest to the blade will result in a shallow cut, whereas using the hole furthest from the blade will result in a deeper cut. The slot on the pusher bar is for fine tuned adjustment.
- Assemble the lift assembly (Ref 1) to the main frame using the two studs that are under the frame and below the front of the console.
- Attach the lift handle (Ref 19) to the lift assembly using cotter pin and machine bushing (Ref 21 & 22). Using rod and yoke (Ref 18 & 9) attach the handle to the lift assembly.
- Put rod ends (Ref 9) onto lift rods (Ref 10) with jam nut first. Adjust to equal lengths. Bolt lift rods to lift arms with ball joints to the outside. Bolt from outside with the 1/2" machine bushing between rod end and lift arm and the 1/2 - 13 nylon lock nut on the inside. Use (Ref 7) hardware.
- Slide Plow under machine and connect to machine. Use clevis pin and bridge pin (Ref 4 & 17).
- Lift up the plow. Using the top hole in the lift rod as a starting point hook on the pusher bars. Use (Ref 6) hardware. The three holes in the lift rods are for adjusting the hand lever. The top hole moves the lever forward and holds the blade with the most clearance. Each hole down moves the lever to the rear of the machine and decreases blade clearance by approximately one inch.
- For fine tuning of blade height off ground twist rod end (Ref 9) on rod (Ref 18). Twisting the rod end out will increase down pressure. Twisting the rod end onto the rod will decrease down pressure.

# 42-136 60" SAND PLOW DRAWING

Front Attachment

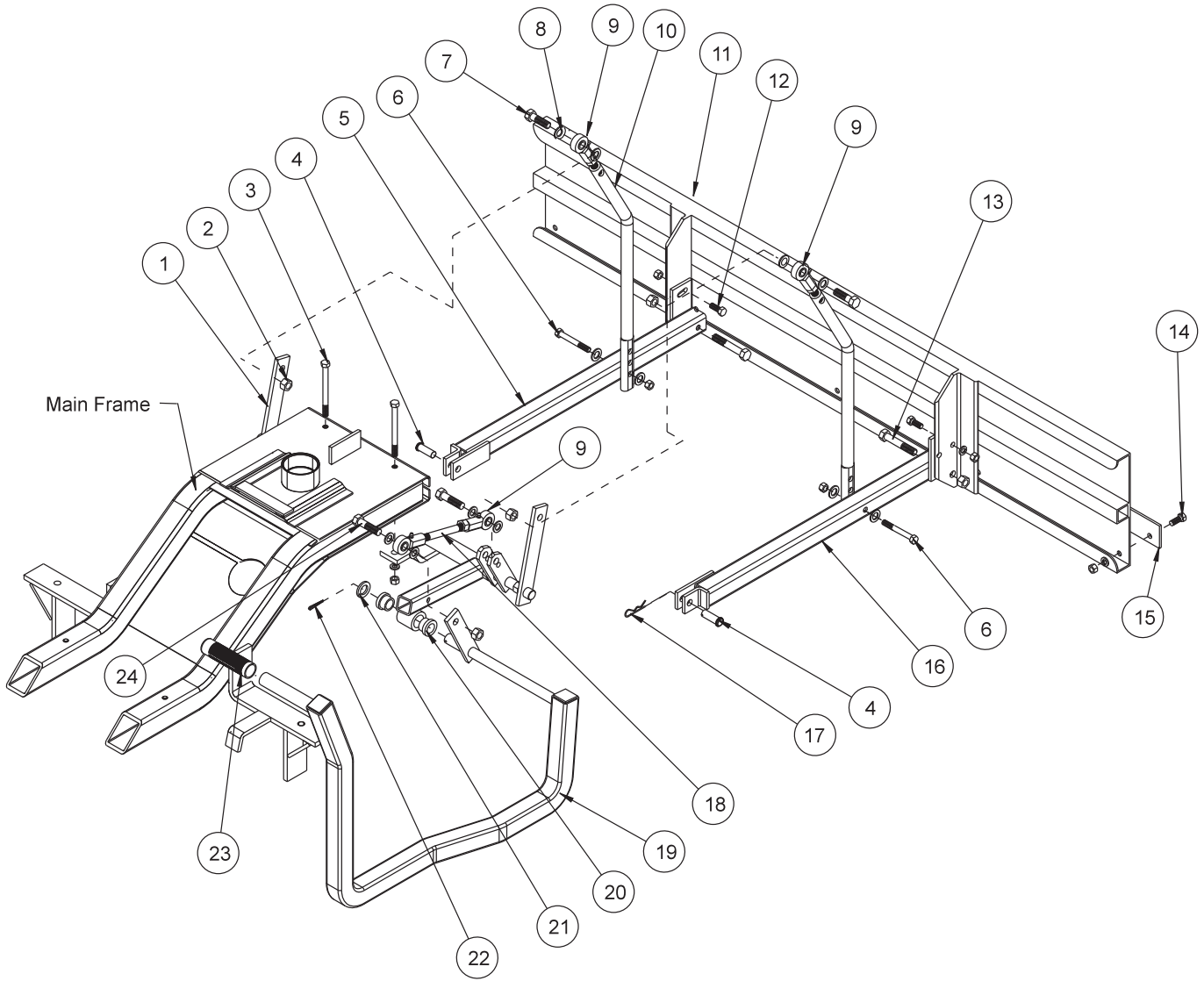



## 42-136 60" SAND PLOW PART LIST

REF#	PART#	DESCRIPTION	QUANTITY
1	42-092	Lift Assembly (includes Ref# 20)	1
2	HNTL-12-13	Lock Nut 1/2 - 13	4
3	HB-38-16-350	Bolt 3/8 - 16 x 3 1/2 (part of main frame)	2
	HWL-38	Lock Washer 3/8	2
	HN-38-16	Nut 3/8 - 16	2
4	HCP-12-150	Clevis Pin 1/2 x 1 1/2	2
5	27-049	Left Pusher Bar	1
6	HB-38-16-300	Bolt 3/8 - 16 x 3	2
	HW-38	Washer 3/8	4
	HNTL-38-16	Lock Nut 3/8 - 16	2
7	HB-12-13-200	Bolt 1/2 - 13 x 2	2
8	HMB-12-14	Machine Bushing 1/2 x 14GA	8
9	80-006	Rod End	4
	HNJ-12-20	Jam Nut 1/2 - 20	4
10	27-073	Lift Rod	2
11	35-011	Aluminum Plow Blade 60"	1
12	HB-38-16-100	Bolt 3/8 - 16 x 1	2
	HW-38	Washer 3/8	2
	HWL-38	Lock Washer 3/8	2
	HN-38-16	Nut 3/8 - 16	2
13	HB-12-13-300	Bolt 1/2 - 13 x 3	2
	HNTL-12-13	Lock Nut 1/2 - 13	2
14	HB-38-16-100	Bolt 3/8 - 16 x 1	5
	HWL-38	Lock Washer 3/8	5
	HN-38-16	Nut 3/8 - 16	5
15	35-012	Wear Blade	1
16	27-050	Right Pusher Bar	1
17	HHP-18	Bridge Pin 1/8	2
18	42-094	Rod	1
19	42-093	Lift Handle	1
20	18-221	Flange Bushing	2
21	HMB-34-14	Machine Bushing 3/4 - 14GA	1
22	HP-18-150	Cotter Pin 1/8 x 1 1/2	1
23	15-019	Grip	1
24	HB-12-13-200	Bolt 1/2 - 13 x 2	2

## INSTALLATION INSTRUCTIONS

- Assemble pusher bars (Ref 5 and 16) to plow (Ref 11) using hardware (Ref 12 & 13). There are 2 holes to bolt the hardware in. Using hole closest to the blade will result in a shallow cut, whereas using the hole furthest from the blade will result in a deeper cut. The slot on the pusher bar is for fine tuned adjustment.
- Assemble the lift assembly (Ref 1) to the main frame using the two studs that are under the frame and below the front of the console.
- Attach the lift handle (Ref 19) to the lift assembly using cotter pin and machine bushing (Ref 21 & 22). Using rod and yoke (Ref 18 & 9) attach the handle to the lift assembly.
- Put rod ends (Ref 9) onto lift rods (Ref 10) with jam nut first. Adjust to equal lengths. Bolt lift rods to lift arms with ball joints to the outside. Bolt from outside with the 1/2" machine bushing between rod end and lift arm and the 1/2 - 13 nylon lock nut on the inside. Use (Ref 7) hardware.
- Slide plow under machine and connect to machine. Use clevis pin and bridge pin (Ref 4 & 17).
- Lift up the plow. Using the top hole in the lift rod as a starting point hook on the pusher bars. Use (Ref 6) hardware. The three holes in the lift rods are for adjusting the hand lever. The top hole moves the lever forward and holds the blade with the most clearance. Each hole down moves the lever to the rear of the machine and decreases blade clearance by approximately one inch.
- For fine tuning of blade height off ground twist rod end (Ref 9) on rod (Ref 18). Twisting the rod end out will increase down pressure. Twisting the rod end onto the rod will decrease down pressure.

# 42-460 40" ANGLE PLOW

Front Attachment

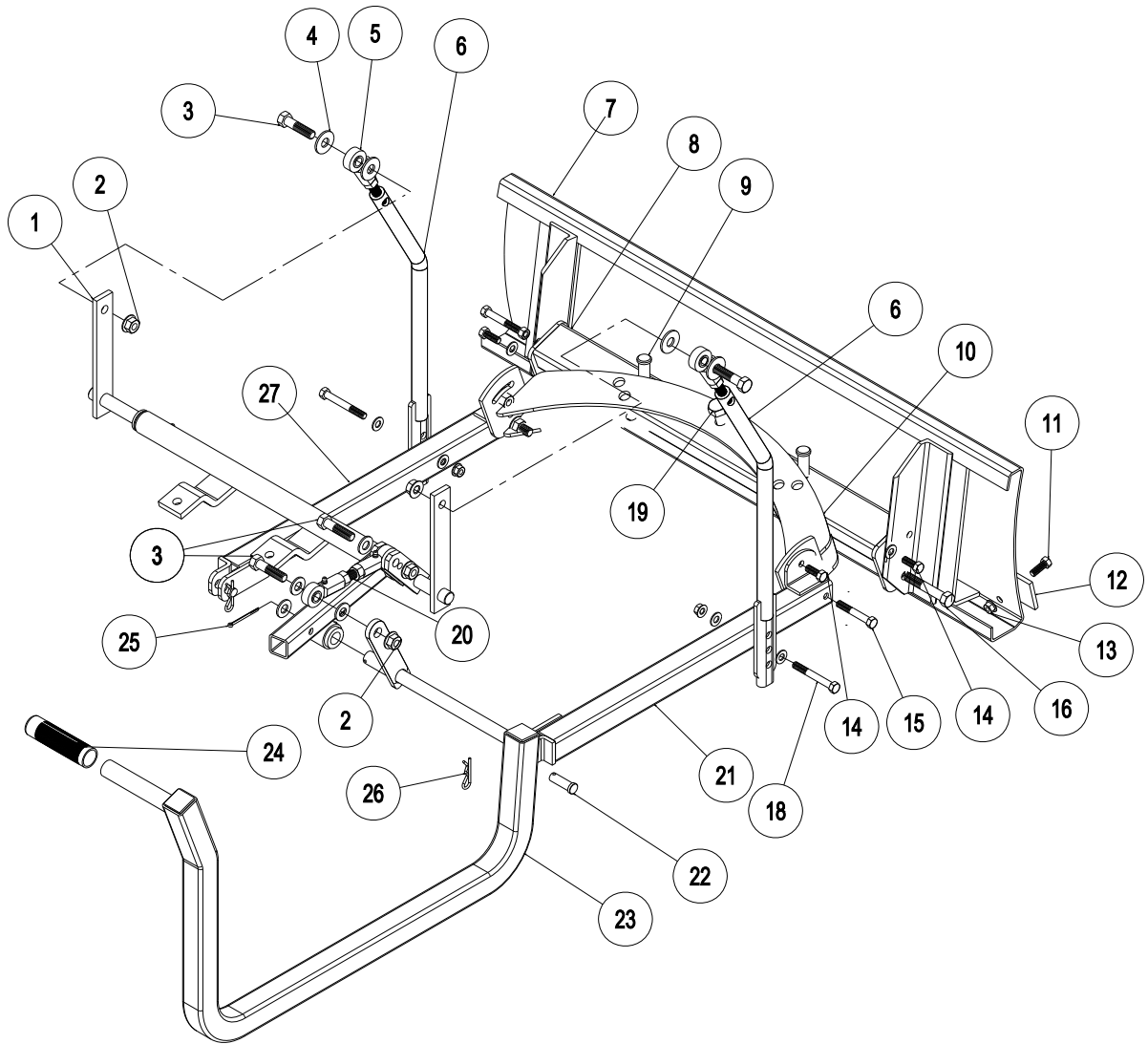

## 40" ANGLE PLOW PARTS LIST

REF#	PART#	DESCRIPTION	QUANTITY
1	42-346	Lift Assembly	1
2	HNTL-12-13	Lock Nut 1/2 - 13	4
3	HB-12-13-200	Bolt 1/2 - 13 x 2	4
4	HMB-12-14	Machine Bushing 1/2 x 14GA	10
5	80-006	Rod End	4
	HNJ-12-20	Jam Nut 1/2 - 20	4
6	27-073	Lift Rod	2
7	27-017	Aluminum Sand Plow Blade	1
8	42-495	Pivot Frame	1
9	HCP-58-250	Clevis Pin 5/8 x 2 1/2	2
	HHP-18	Bridge Pin 1/8	2
10	42-456	Plow Mount	1
11	HB-38-16-100	Bolt 3/8 - 16 x 1	4
12	13-167	Wear Blade	1
13	HNFL-38-16	Flange Whiz Lock Nut 3/8 - 16	4
14	HB-38-16-125	Bolt 3/8 - 16 x 1 1/4	4
	HW-38	Washer 3/8	4
	HWL-38	Lock Washer 3/8	4
	HN-38-16	Nut 3/8 - 16	4
15	HB-38-16-250	Bolt 3/8 - 16 x 2 1/2	2
	HNTL-38-16	Lock Nut 3/8 - 16	2
16	HB-12-13-200	Bolt 1/2 - 13 x 2	2
	HNTL-12-13	Lock Nut 1/2 - 13	2
18	HB-38-16-250	Bolt 3/8 - 16 x 2 1/2	2
	HW-38	Washer 3/8	4
	HNTL-38-16	Lock Nut 3/8 - 16	2
19	HB-58-11-300	Bolt 5/8 - 11 x 3	1
	HNTL-58-11	Lock Nut 5/8 - 11	1
20	42-348	Rod	1
21	42-458	Right Pusher Bar	1
22	HCP-12-150	Clevis Pin 1/2 x 1 1/2	2
23	42-347	Lift Handle	1
	18-221	Flange Bushing	2
24	15-019	Grip	1
25	HP-18-150	Cotter Pin 1/8 x 1 1/2	1
	HMB-34-14	Machine Bushing 3/4 - 14GA	1
26	HHP-18	Bridge Pin 1/8	2
27	42-459	Left Pusher Bar	1

# 42-490 60" ANGLE PLOW

Front Attachment

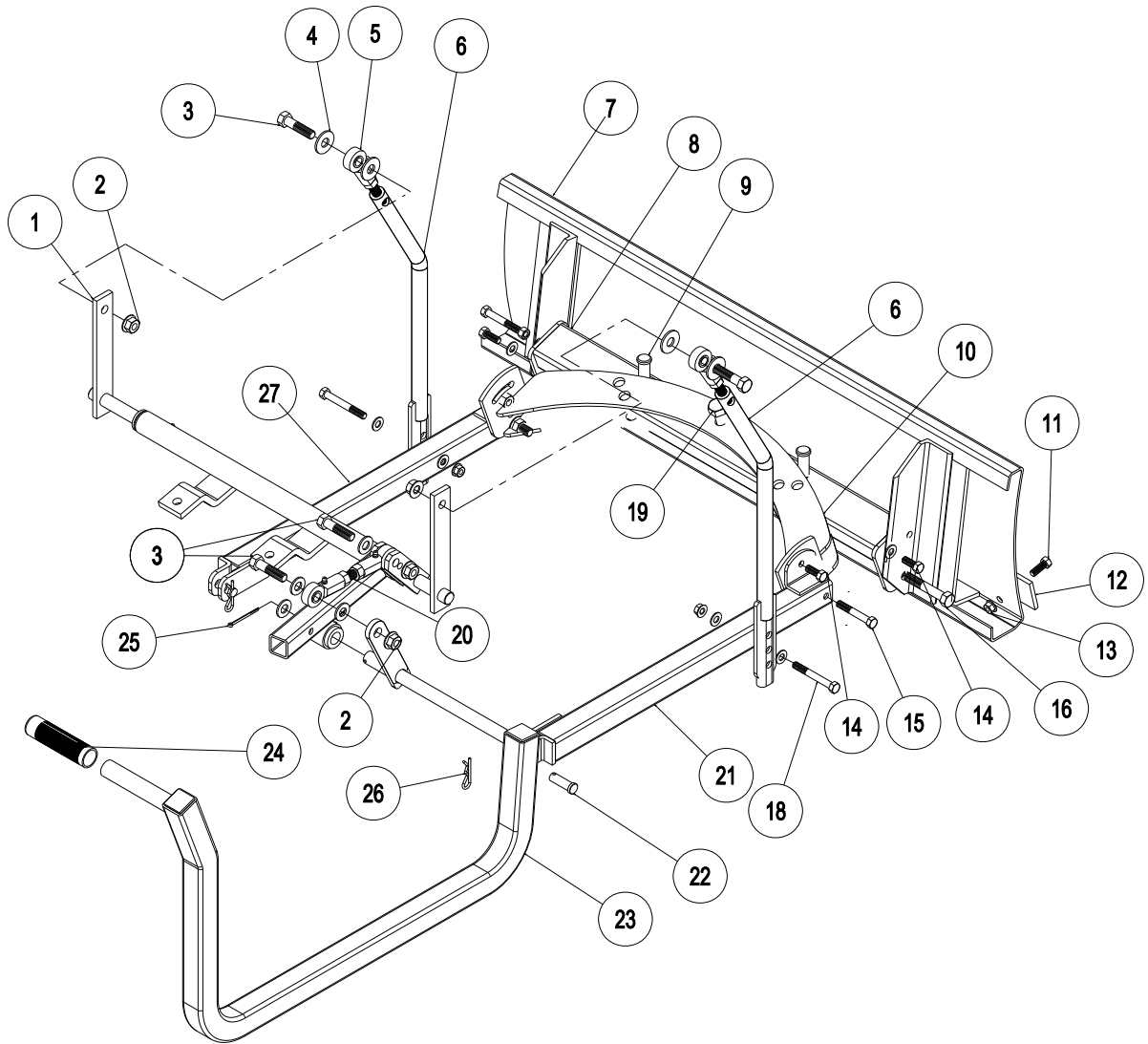

## 60" ANGLE PLOW PARTS LIST

REF#	PART#	DESCRIPTION	QUANTITY
1	42-346	Lift Assembly	1
2	HNTL-12-13	Lock Nut 1/2 - 13	4
3	HB-12-13-200	Bolt 1/2 - 13 x 2	4
4	HMB-12-14	Machine Bushing 1/2 x 14GA	10
5	80-006	Rod End	4
	HNJ-12-20	Jam Nut 1/2 - 20	4
6	27-073	Lift Rod	2
7	35-012	Aluminum Sand Plow Blade	1
8	42-495	Pivot Frame	1
9	HCP-58-250	Clevis Pin 5/8 x 2 1/2	2
	HHP-18	Bridge Pin 1/8	2
10	42-456	Plow Mount	1
11	HB-38-16-100	Bolt 3/8 - 16 x 1	5
12	35-011	Wear Blade	1
13	HNFL-38-16	Flange Whiz Lock Nut 3/8 - 16	5
14	HB-38-16-125	Bolt 3/8 - 16 x 1 1/4	4
	HW-38	Washer 3/8	4
	HWL-38	Lock Washer 3/8	4
	HN-38-16	Nut 3/8 - 16	4
15	HB-38-16-250	Bolt 3/8 - 16 x 2 1/2	2
	HNTL-38-16	Lock Nut 3/8 - 16	2
16	HB-12-13-200	Bolt 1/2 - 13 x 2	2
	HNTL-12-13	Lock Nut 1/2 - 13	2
18	HB-38-16-250	Bolt 3/8 - 16 x 2 1/2	2
	HW-38	Washer 3/8	4
	HNTL-38-16	Lock Nut 3/8 - 16	2
19	HB-58-11-300	Bolt 5/8 - 11 x 3	1
	HNTL-58-11	Lock Nut 5/8 - 11	1
20	42-348	Rod	1
21	42-458	Right Pusher Bar	1
22	HCP-12-150	Clevis Pin 1/2 x 1 1/2	2
23	42-347	Lift Handle	1
	18-221	Flange Bushing	2
24	15-019	Grip	1
25	HP-18-150	Cotter Pin 1/8 x 1 1/2	1
	HMB-34-14	Machine Bushing 3/4 - 14GA	1
26	HHP-18	Bridge Pin 1/8	2
27	42-459	Left Pusher Bar	1

# 42-315 LIGHT KIT - FRONT LIGHT MOUNT DRAWING

Front Attachment

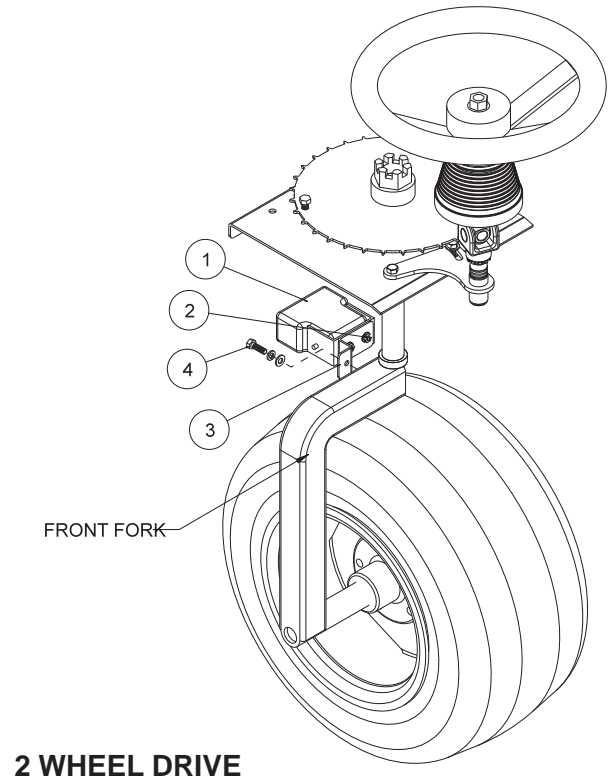
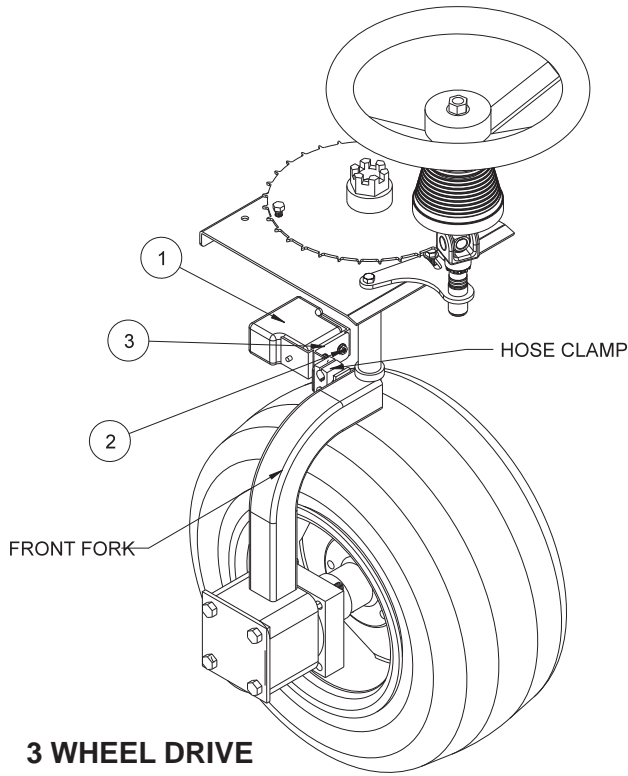

3 WHEEL DRIVE

2 WHEEL DRIVE

# WIRING DRAWING

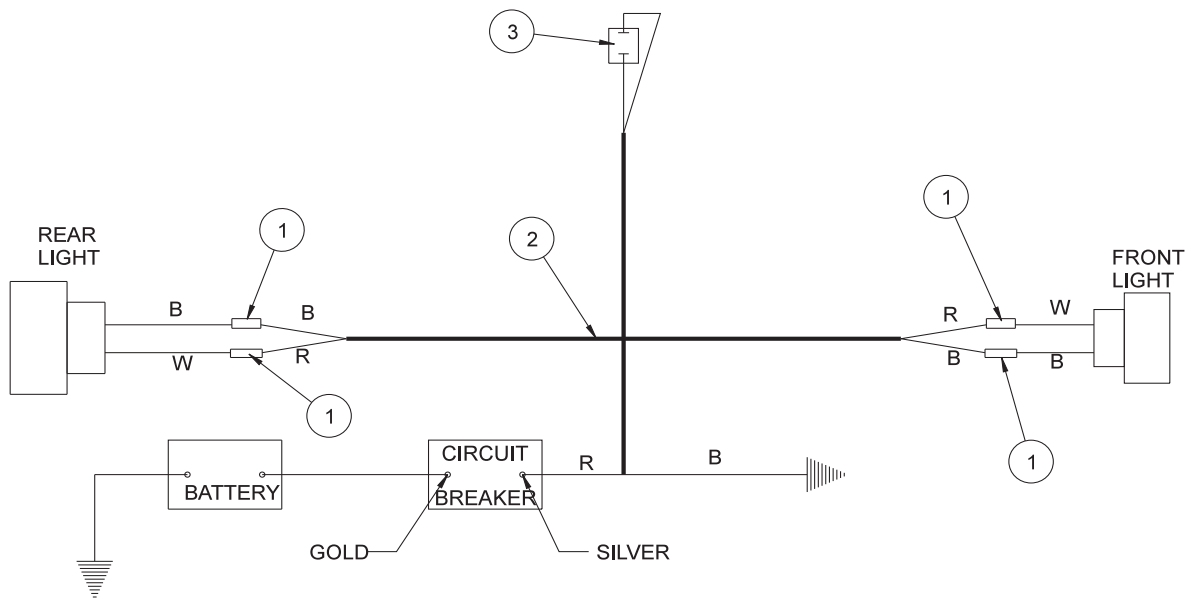

## 42-315 LIGHT KIT PART LIST

REF#	PART#	DESCRIPTION	QUANTITY
1	42-317	Front Light	1
	42-317-01	Replacement Bulb	1
2	HSTP-14-20-075	Phillips Machine Screw $\frac{1}{4}$ - 20 x $\frac{3}{4}$	2
	HNFL-14-20	Flange Whiz Lock Nut $\frac{1}{4}$ - 20	2
3	42-323	Front Light Mount	1
4	HB-516-18-100	Bolt $\frac{5}{16}$ - 18 x 1(2 WD Only)	1
	HW-516	Washer $\frac{5}{16}$ (2 WD Only)	1
	HWL-516	Lockwasher $\frac{5}{16}$ (2 WD Only)	1

## FRONT LIGHT INSTALLATION

### SUPER STAR 3 WHEEL DRIVE FRONT LIGHT INSTALLATION

1. Remove bolt and strong back from hose clamp on front of front fork. Place front light mount (Ref 3) on hose clamp and replace bolt and strong back.
2. Bolt front light (Ref 1) to front light mount, using the  $\frac{1}{4}$  - 20 machine screws and whiz lock nuts. Be sure wires are up.

### SUPER STAR 2 WHEEL DRIVE FRONT LIGHT INSTALLATION

1. You will have to drill and tap a  $\frac{5}{16}$  - 18 hole in the front fork approximately 1" from the end, and centered, where the steering shaft is welded.
2. Bolt front light mount (Ref 3) to the front fork using the  $\frac{5}{16}$  -18 bolt, lockwasher and washer (Ref 4).
3. Bolt front light (Ref 1) to front light mount, using the  $\frac{1}{4}$  - 20 machine screws and whiz lock nuts. Be sure wires are up.

## WIRING PARTS LIST

REF#	PART#	DESCRIPTION	QUANTITY
1	8875	Bullet Terminal	4
	8963	Heat Shrink $\frac{1}{4}$ "	4
2	42-319	Wire Harness	1
	HLC-58	Loom Clamp $\frac{5}{8}$ "	2
3	12-003	Toggle Switch	1
	15-472	Switch Boot	1

## WIRING INSTALLATION

1. Remove nut from left hand seat studs and place two loom clamps (HLC-58) onto seat stud. Hold in place with the nut.
2. Drill a  $\frac{1}{2}$ " hole in fiberglass control panel 1" from 2WD/3WD toggle switch. (NOTE: Use 2WD/3WD hole if not being used).
3. Hook red wire from the wire harness to toggle switch. Place toggle switch (Ref 3) into hole. Install switch boot.
4. Run wire harness (Ref 2) to the front light. Snip the factory installed ends on headlight wires and install the heat shrink and the bullet terminal (Ref 1) provided. Plug in wire harness to front head light. Do the same to the rear light.
5. Run the red wire to the silver post of the circuit breaker and the black to the ground battery wire on the engine.
6. Hook wire harness up in the loom clamps installed earlier.
7. Rotate front wheel to stop. Check for wire routing and interference. Place warning decal on lights.
8. Test headlights before putting machine into service.



**Do not touch lights. Very Hot.**



# 42-315 REAR LIGHT MOUNT DRAWING

Front Attachment

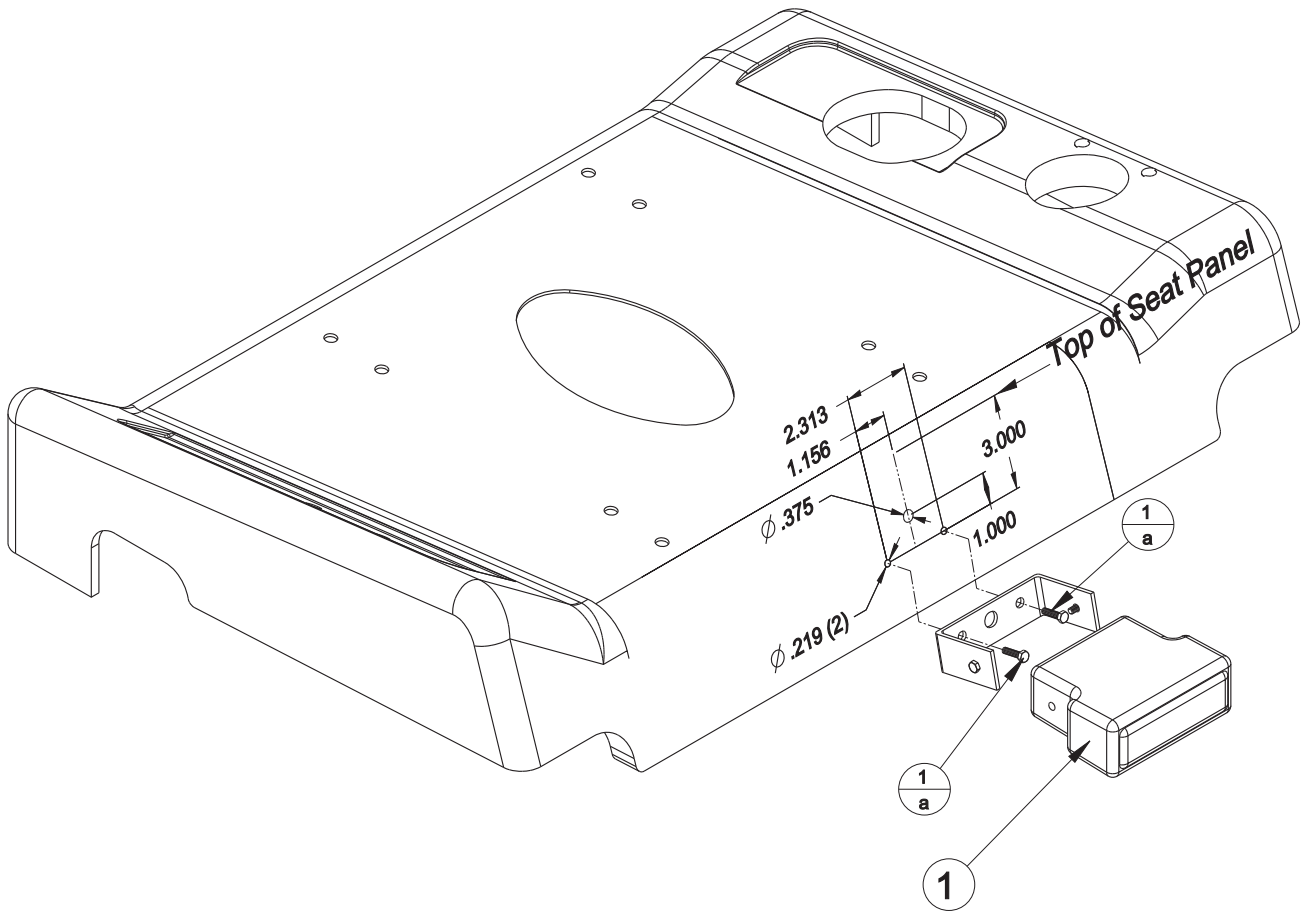



## 42-315 REAR LIGHT MOUNT PARTS LIST

REF#	PART#	DESCRIPTION	QUANTITY
1	42-317	Light	1
	42-317-01	Replacement Bulb	1
1a	HSM-10-32-075	Machine Screw 10-32 x $\frac{3}{4}$	2
1b	HNFL-10-32	Flange Whiz Lock Nut 10-32 <i>(not illustrated)</i>	2

## REAR LIGHT INSTALLATION

**NOTE:** *The rear light of this kit must be installed in the position specified to prevent interference with the 42-210 Grader Blade Kit (if installed) on your machine.*

1. Find the center of the seat panel. Measure down 3" on this center line and mark the centers for two,  $\text{Ø}\frac{7}{32}$  holes at the positions illustrated. Measure 1" above the previous two marks for the position of the  $\text{Ø}\frac{3}{8}$  hole.
2. Once the hole positions are marked proceed to drill the holes to the sizes specified.
3. Next, position Light (Ref. 1) with wires up, and using the #10 - 32 Machine Screws (Ref 1a) and #10 - 32 Whiz-Loc Nuts (Ref. 1b), mount the Light to the Seat Panel.
4. Run wires through the  $\text{Ø}\frac{3}{8}$  hole and connect according to the **Wiring Drawing** on the previous pages.

## ACCESSORIES

Plows .....	A
13-731 Single Bank Valve .....	2
43-003 Hydraulic Sand Plow .....	4
42-011 Sand Plow(Steel & Aluminum) .....	8
42-136 60" Sand Plow .....	10
42-460 40" Angle Plow .....	12
42-490 60" Angle Plow .....	14
42-315 Light Kit .....	16
<b>Belly Attachments .....</b>	<b>B</b>
42-223 Adjustable Disc Edger .....	2
42-750 Cart Path & Sidewalk Edger .....	4
42-130 Wedd Cultivator .....	6
42-008 Sand Cultivator .....	8
42-340 Sand Cultivator w/ Spring Tine .....	10
42-341 Sand Cultivatore w/ Castor Wheels .....	12
42-010 Construction Leveling Blade .....	14
42-210 Grader Blade Kit .....	16
42-178 Infield Scarifier(vertical blades) .....	18
42-179 Infield Scarifier(chisel blades) .....	22
42-285 Scarifier w/ Vertical Blades .....	26
Rear Attachments .....	C
42-391Q 72" Pro-Brush Tournament Rake .....	2
43-392Q 84" Pro-Brush Tournament Rake .....	6
42-130Q 84" Mild Steel Rake .....	10
42-132Q 72" Mild Steel Rake .....	14
13-438Q Rake with Finishing Blades .....	18
13-298Q Fan Rake .....	20
26-007Q Professional Field Finisher .....	22
42-185 Drag Mat Kit .....	22
43-002Q Flex Action Field Finisher w/ Brush .....	24
26-008Q Flex Action Field Finisher .....	28
42-586Q Green Star RBS Main Frame .....	30
42-581 Green Star RBS Roller .....	32
42-585 Green Star RBS Brush .....	34
42-582 Green Star RBS Spiker .....	36
Warranty .....	Inside Back Cover

Front Attachment

Center Attachment

Rear Attachment

# 42-223 ADJUSTABLE DISC EDGER DRAWING

Center Attachment

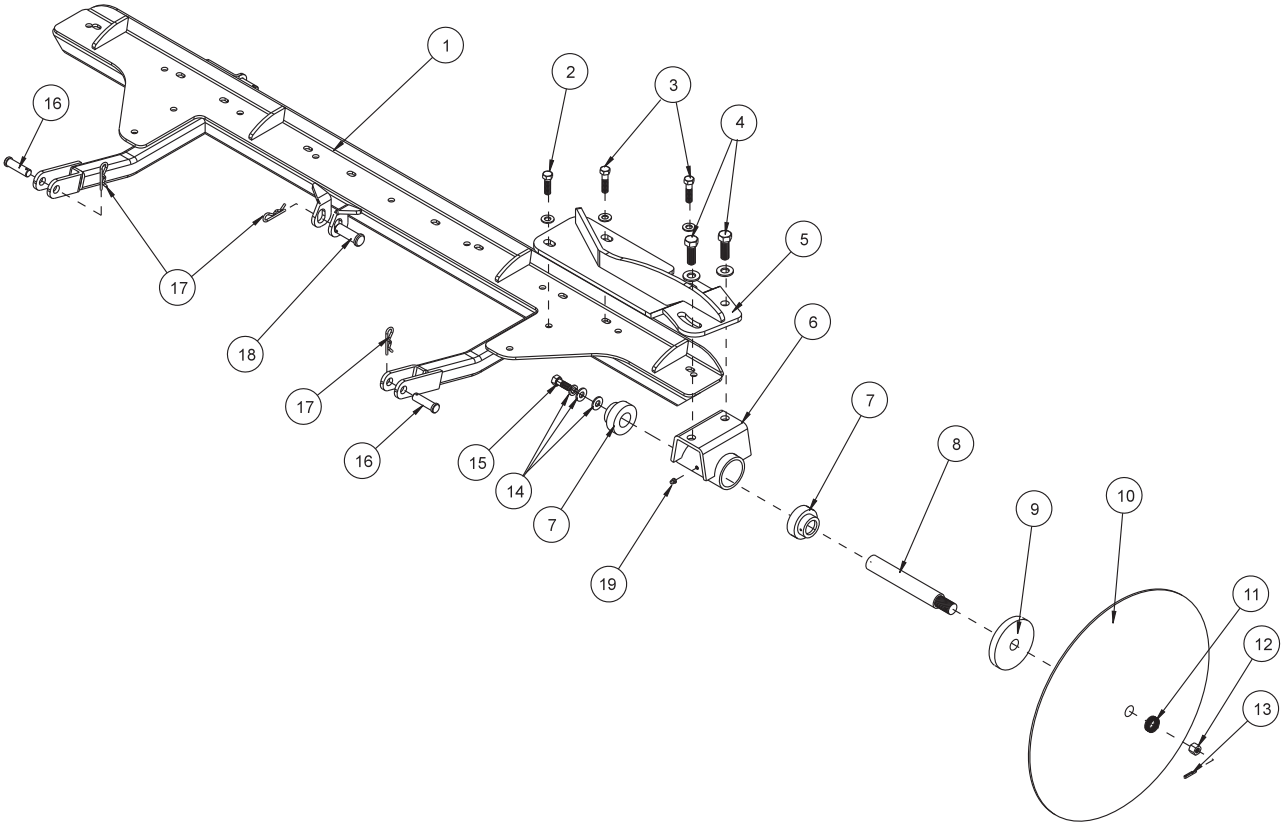

## 42-223 ADJUSTABLE DISC EDGER PARTS LIST

REF#	PART#	DESCRIPTION	QUANTITY
1	42-203	Attachment Lift Assembly	1
2	HB-38-16-125	Bolt $\frac{3}{8}$ - 16 x $1\frac{1}{4}$	1
	HW-38	Washer $\frac{3}{8}$	1
	HNTL-38-16	Lock Nut $\frac{3}{8}$ -16	1
3	HB-38-16-150	Bolt $\frac{3}{8}$ - 16 x $1\frac{1}{2}$	2
	HW-38	Washer $\frac{3}{8}$	2
	HNTL-38-16	Lock Nut $\frac{3}{8}$ - 16	2
4	HB-12-13-150	Bolt $\frac{1}{2}$ - 13 x $1\frac{1}{2}$	2
	HW-12	Washer $\frac{1}{2}$	2
	HNTL-12-13	Lock Nut $\frac{1}{2}$ - 13	2
5	42-224	Edger Mount	1
6	13-203	Spindle	1
7	13-391	Bearing and Collar	2
8	13-206	Spindle Shaft	1
9	13-205	$\frac{1}{2}$ Disc Flange	1
10	13-204	Disc	1
11	HMB-34-10	Machine Bushing $\frac{3}{4}$ x 10GA	4
12	HNA-34-16	Axle Nut $\frac{3}{4}$ - 16	1
13	HP-18-150	Cotter Pin $\frac{1}{8}$ x $1\frac{1}{2}$	1
14	HWL-38	Washer $\frac{3}{8}$	1
	HW-516	Washer $\frac{5}{16}$	1
	HW-716	Washer $\frac{7}{16}$	1
15	HB-38-16-100	Bolt $\frac{3}{8}$ -16 x 1	1
16	HCP-12-200	Clevis Pin $\frac{1}{2}$ x 2	2
17	HHP-18	Bridge Pin $\frac{1}{8}$	3
18	HCP-58-250	Clevis Pin $\frac{5}{8}$ x $2\frac{1}{2}$	1
19	HG-14-28-180	Grease Fitting $\frac{1}{4}$ - 28 x 180	1

Center Attachment

## INSTALLATION INSTRUCTIONS

1. For initial assembly, bolt spindle assembly (Ref 6) to the edger mount (Ref 5). Use the  $\frac{1}{2}$  - 13 bolts, washers and lock nuts (Ref 4) to hold in place.
2. Make sure the  $\frac{1}{2}$ " disc flange (Ref 9) is on the spindle shaft (Ref 8) up to the shoulder. Then place the disc (Ref 10) onto the shaft, curved towards the spindle housing, followed by four machine bushings (Ref 11), and the axle nut (Ref 12).
3. Tighten axle nut and slide in the cotter pin (Ref 13).
4. The edger mount mounts onto the attachment lift assembly (Ref 1). Use the  $\frac{3}{8}$  bolts, washers and lock nuts (Ref 2 and 3) with the  $1\frac{1}{4}$ " bolt going into the last hole on the mount plate.
5. The Edger mounts under the center of the trap rake.
6. Place the handle and linkage onto the empty linkage port of the two bank valve on the machine.
7. Start the engine and lower the cylinder for the attachment lift FULLY. Stop engine.
8. Slide Edger under the trap rake from the right side.
9. Position the lift arms on the attachment lift assembly to the lift brackets on the machine. Hold in place with  $\frac{1}{2}$  x 2 clevis pin and bridge pins (Ref 16 and 17).
10. Attach the cylinder to the center tab on the attachment lift assembly using the  $\frac{5}{8}$  x  $2\frac{1}{2}$  clevis pin and bridge pin (Ref 17 and 18).
11. Start engine and test lift and Edger to make sure all works well.



# 42-750 CART PATH AND SIDEWALK EDGER DRAWING

Center Attachment

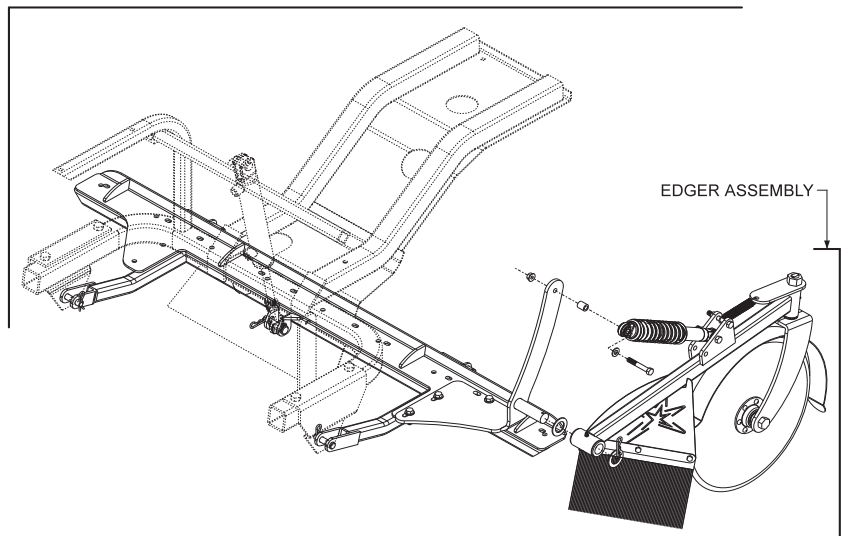
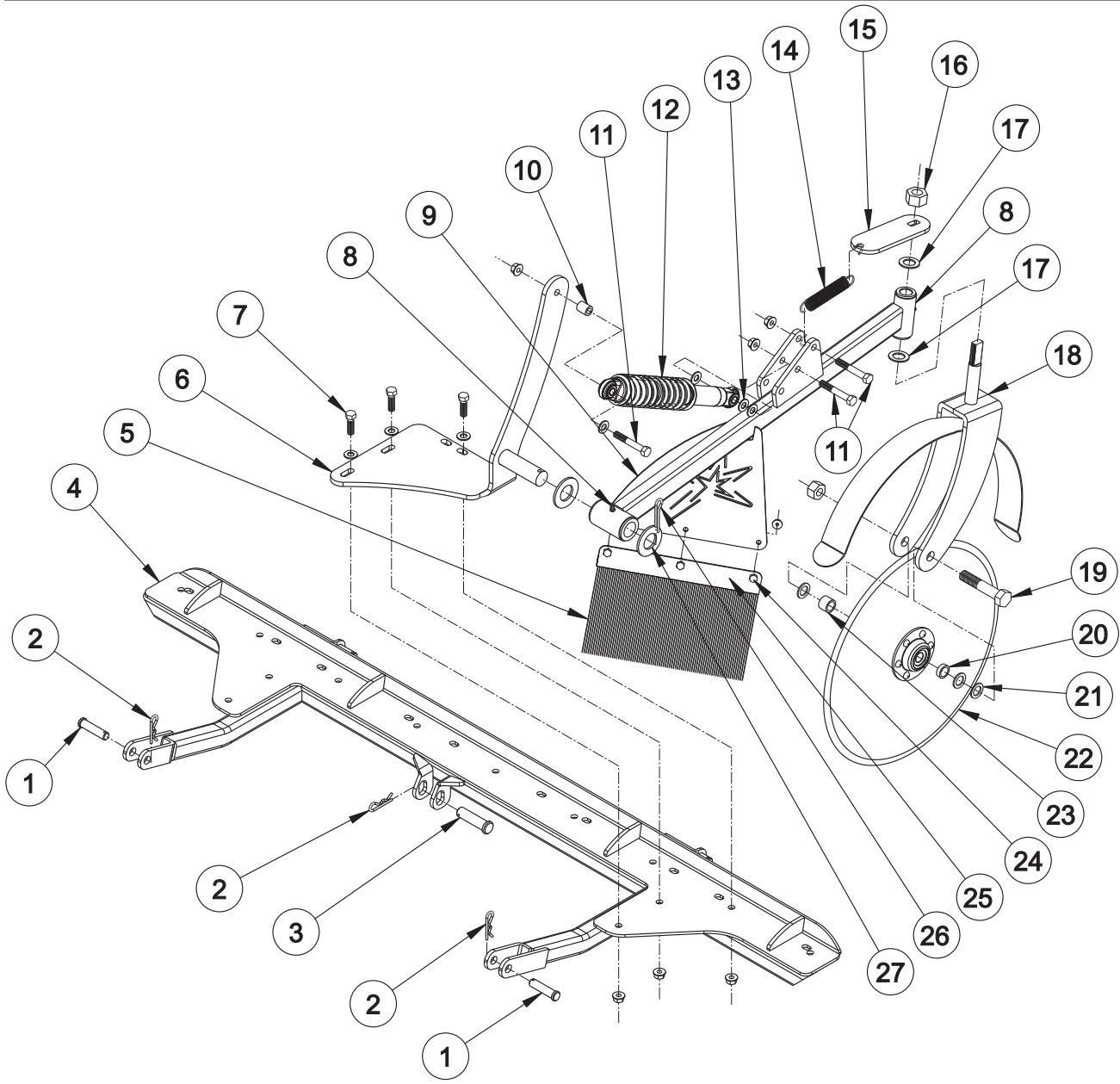

## 42-750 CART PATH AND SIDEWALK EDGER PARTS LIST

REF#	PART#	DESCRIPTION	QUANTITY
1	HCP-12-200	Clevis Pin, 1/2 x 2	2
2	HHP-18-100	Bridge Pin, 1/8 x 1	3
3	HCP-58-250	Clevis Pin, 5/8 x 2 1/2	1
4	42-203	Attachment Lift Assembly	1
5	42-758	Brush	1
6	42-754	Edger Mount	1
7	HB-38-16-125	Bolt, 3/8 - 16 x 1 1/4	3
	HNFL-38-16	Flange Whiz-Lock Nut, 3/8 - 16	3
	HW-38	Flat Washer, 3/8	3
8	HG-14-28-180	Grease Fitting, 1/4 - 28 x 180° (Part of 42-755)	2
9	42-755	Edger Arm	1
10	10-134	Spacer	1
11	HB-38-16-250	Bolt, 3/8 - 16 x 2 1/2	3
	HNFL-38-16	Flange Whiz-Lock Nut, 3/8 - 16	3
12	60-123	Shock Absorber	1
13	HW-38	Flat Washer, 3/8	3
14	48-109	Spring	1
15	42-757	Spring Mount	1
16	HNTL-34-16	Lock Nut, 3/4 - 16	1
17	HMB-34-10	Machine Bushing, 3/4 x 10GA	2
18	42-756	Edger Fork	1
19	HB-58-11-325	Bolt, 5/8 - 11 x 3 1/4	1
	HNCL-58-11	Center Lock Nut, 5/8 - 11	1
20	60-325	Spacer	1
21	HMB-58-14	Machine Bushing, 5/8 x 10GA	3
22	42-752	Edger Blade	1
23	76-298	Spacer	2
24	HB-14-20-075	Bolt, 1/4 - 20 x 3/4	3
	HNFL-14-20	Flange Whiz-Lock Nut, 1/4 - 20	3
25	42-759	Brush Holder	1
26	HP-18-150	Cotter Pin 1/8 x 1 1/2	1
27	HMB-100-14	Machine Bushing, 1 x 14GA	2

Center Attachment

## INSTALLATION INSTRUCTIONS

For your convenience and ease of installation, a major set of components are pre-assembled at the factory. This is the "Edger Assembly" and includes Reference #'s 11 thru 25.

- Slide Attachment Lift Assembly (Ref 4) under machine and attach using (2) 1/2 x 2" Clevis Pins (Ref 1) & (2) 1/8" Bridge Pins (Ref 2). Connect the free end of the hydraulic cylinder to the Attachment Lift Assembly (Ref 4) as illustrated using the 5/8 x 2 1/2 Clevis Pin (Ref 3) & (1) 1/8" Bridge Pin (Ref 2).
- Attach the Edger Mount (Ref 6) to the Attachment Lift Assembly (Ref 4) using (3) 3/8 - 16 x 1 1/4 bolts, 3/8 Flat Washers and 3/8 - 16 Whiz-Lock Nuts (Ref 7).
- Now slide (1) 1" Machine Bushing (Ref 27) on the Edger Mount's (Ref 6) pin. Next install the "Edger Assembly" (see sidebar) onto the pin. Place the second 1" Machine Bushing (Ref 27) on the pin. Secure with a 1/8 x 1 1/2 Cotter Pin (Ref 26).
- Slide (1) 3/8" Flat Washer onto (1) 3/8 - 16 x 2 1/2 bolt & insert this in the free end of the Shock Absorber (Ref 12). Next, slide the Spacer (Ref 10) onto the bolt and use (1) 3/8 - 16 Whiz-Lock Nut to secure the Shock Absorber (Ref 12) to the Edger Mount (Ref 6) as illustrated.
- Grease all Grease Fittings (Ref 8) and check all fasteners for proper installation.



# 43-130 WEED CULTIVATOR

Center Attachment

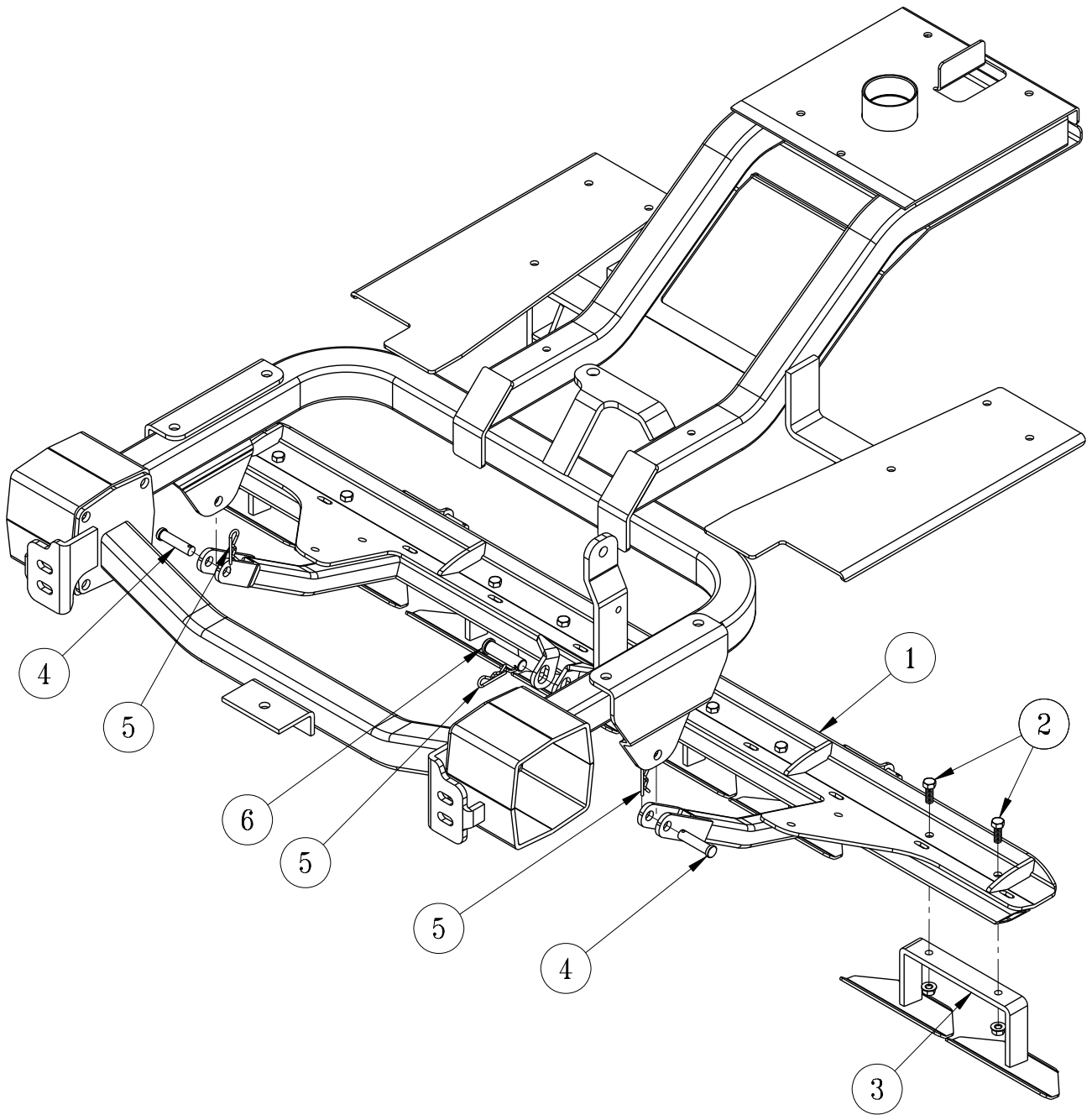

## 43-130 WEED CULTIVATOR

REF#	PART #	DESCRIPTION	QUANTITY
1	43-131	Attachment Lift Assembly	1
2	HB-38-16-125	Bolt, $\frac{3}{8}$ - 16 x $1\frac{1}{4}$	8
	HNFL-38-16	Flange Nut, $\frac{3}{8}$ - 16	8
3	13-096	Blade Assembly	4
4	HCP-12-200	Clevis Pin $\frac{1}{2}$ x 2	2
5	HHP-18	Bridge Pin $\frac{1}{8}$	3
6	HCP-58-250	Clevis Pin $\frac{5}{8}$ x $2\frac{1}{2}$	1

Center Attachment





# 42-008 SAND CULTIVATOR DRAWING

Center Attachment

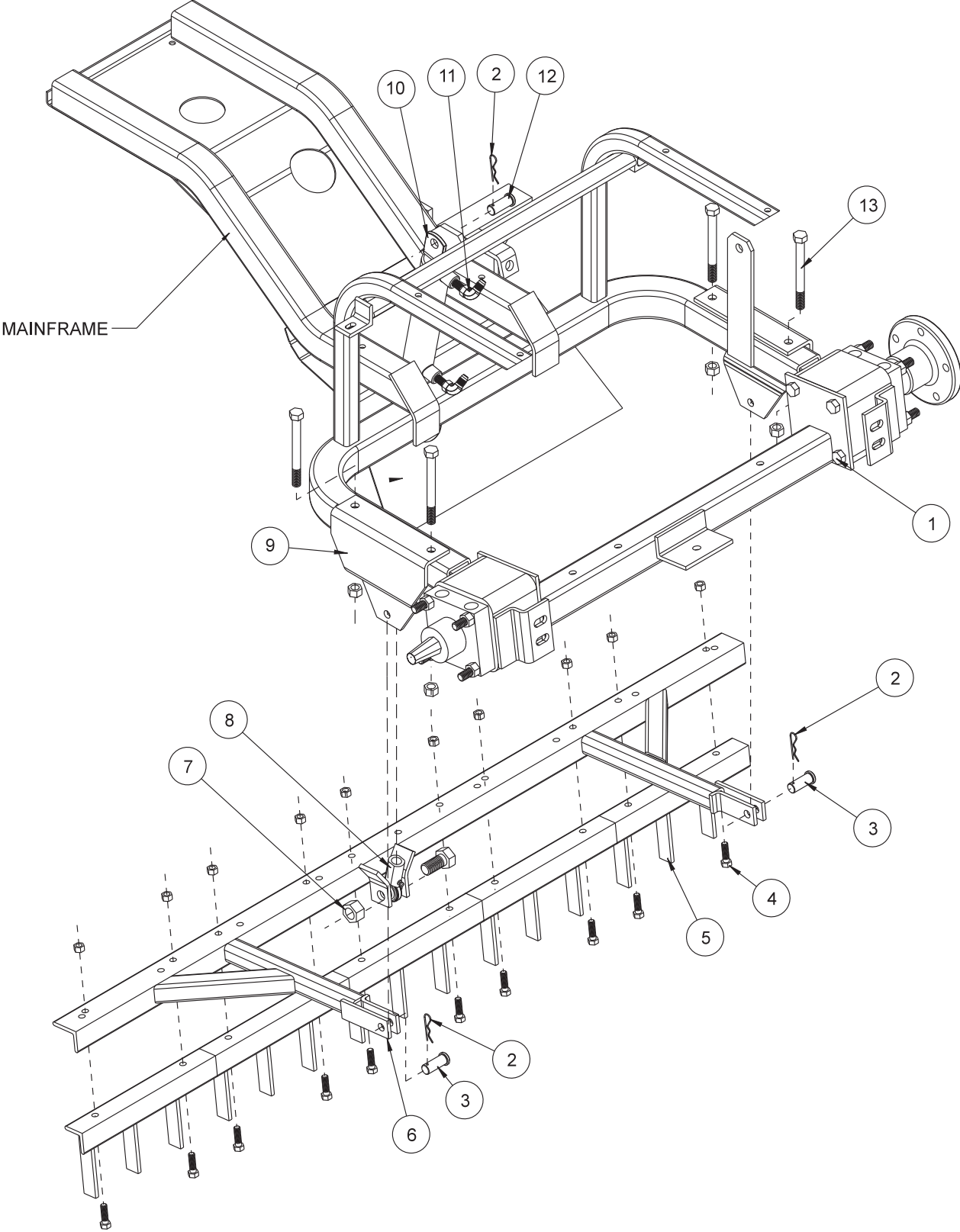

## 42-008 SAND CULTIVATOR PARTS LIST

REF#	PART#	DESCRIPTION	QTY
1	HCP-58-175	Clevis Pin $\frac{5}{8}$ - $1\frac{3}{4}$	1
2	10-135	Hydraulic Cylinder	1
3	18-168	90° Elbow	2
4	42-217	Cylinder Mount	1
5	HB-12-13-500	Bolt $\frac{1}{2}$ - 13 x 5	4
	HNTL-12-13	Lock Nut $\frac{1}{2}$ - 13	4
6	42-015	Attachment Mount	2
*7	HHP-18	Bridge Pin $\frac{1}{8}$	3
*9	HB-38-16-125	Bolt $\frac{3}{8}$ - 16 x $1\frac{1}{4}$	10
	HNTL-38-16	Lock Nut $\frac{3}{8}$ - 16	10
*10	42-038	Tine Segment	5
*11	HCP-12-200	Clevis Pin $\frac{1}{2}$ x 2	2
*12	42-203	Attachment Lift	1
*13	HCP-58-250	Clevis Pin $\frac{5}{8}$ x $2\frac{1}{2}$	1
14	18-154	Rod End	1
*	42-008	Sand Cultivator (all other parts reference only)	

## INSTALLATION INSTRUCTIONS

1. Install valve handle with linkage (13-672) onto valve.
2. Remove the cylinder mount (Ref 4) from the machine.
3. Tine Segments (Ref 10) should be bolted to the attachment lift (Ref 12). Attach the attachment lift to (Ref 12) attachment mount using (Ref 11 & 7) clevis pin and bridge pin.
4. Lift attachment lift up or extend cylinder so rod end (Ref 14) lines up with the holes on the center of the attachment lift. Use clevis pin and bridge pin (Ref 7 and 13) to fasten cylinder to sand cultivator.
6. Turn machine on and test for proper operation.

# 42-340 SAND CULTIVATOR WITH SPRING TINES DRAWING

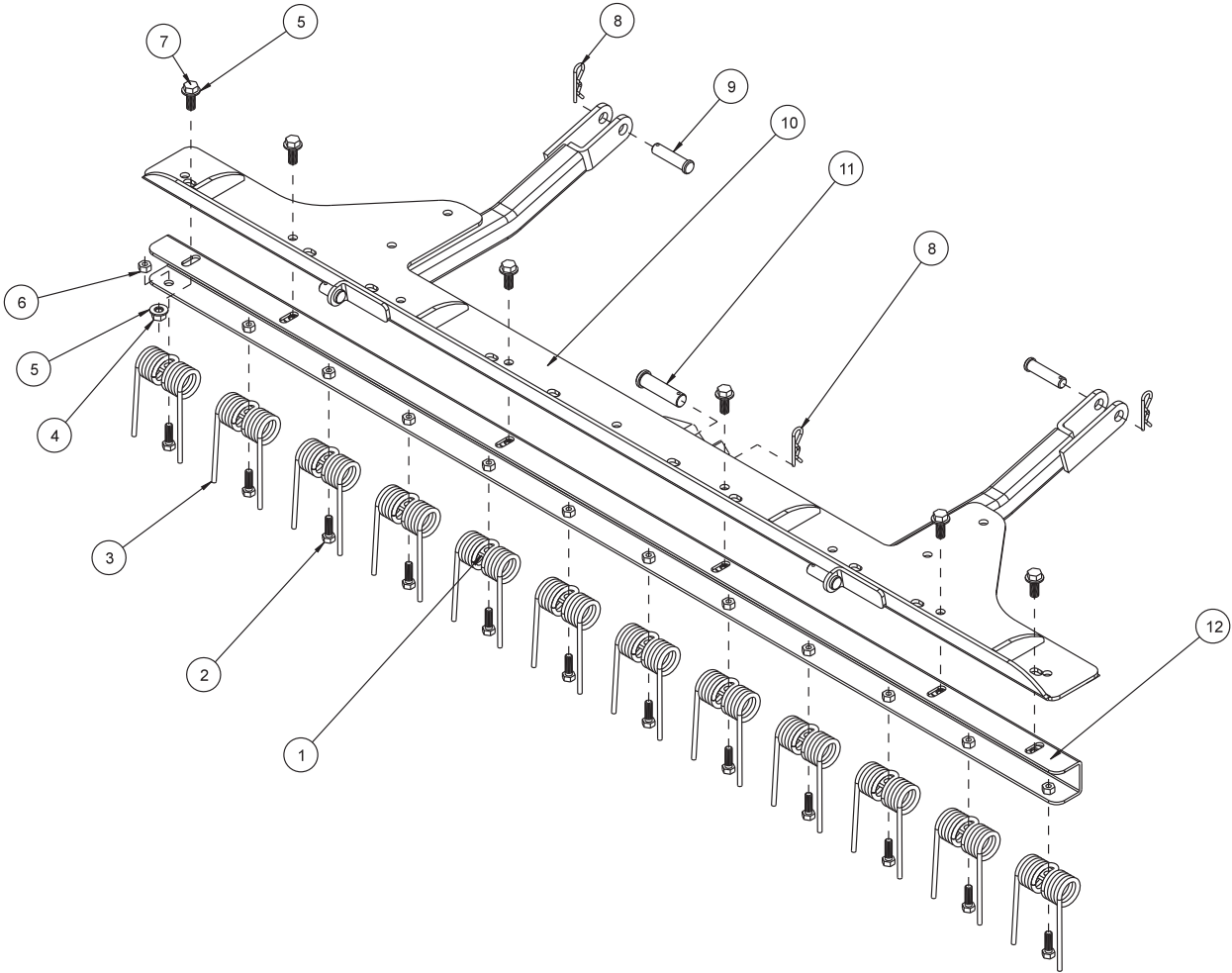

Center Attachment

## 42-340 SAND CULTIVATOR WITH SPRING TINES PARTS LIST

REF#	PART#	DESCRIPTION	QUANTITY
1	42-177	Spring Holder	12
2	HB-516-18-100	Hex Bolt $\frac{5}{16}$ - 18 x 1	12
3	42-122	Rake Spring	12
4	HNTL-38-16	Lock Nut $\frac{3}{8}$ - 16	6
5	HW-38	Flat Washer $\frac{3}{8}$	12
6	HNTL-516-18	Lock Nut $\frac{5}{16}$ - 18	12
7	HB-38-16-100	Hex Bolt $\frac{3}{8}$ - 16 x 1	6
8	HHP-18	Bridge Pin 1/8	3
9	HCP-12-200	Clevis Pin $\frac{1}{2}$ x 2	2
10	42-203	Attachment Lift Bar	1
11	HCP-58-250	Clevis Pin $\frac{5}{8}$ x 2 $\frac{1}{2}$	1
12	42-343	Spring Bar	1

# 42-341 FIELD SCARIFIER WITH TINES AND CASTOR WHEELS DRAWING

Center Attachment

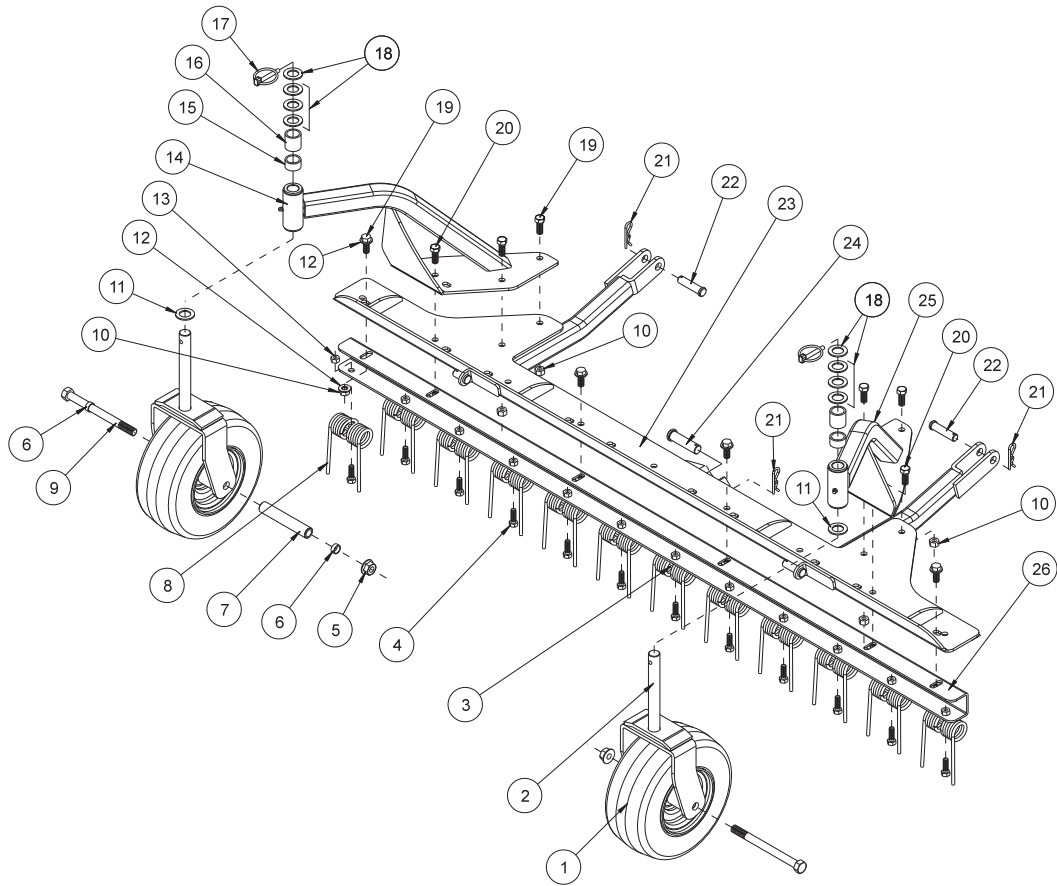

## 42-341 FIELD SCARIFIER WITH TINES AND CASTOR WHEELS PARTS LIST

REF#	PART#	DESCRIPTION	QUANTITY
1	42-202	Tire & Wheel	2
	42-202-01	Tire 9 x 3.5 x 4 PLY (Part of 42-202)	2
	42-202-02	Wheel (Part of 42-202)	2
	42-202-03	Cap (Part of 42-202)	4
	42-202-04	Bearing (Part of 42-202)	4
	42-202-05	Seal (Part of 42-202)	4
2	42-204	Castor Fork	2
3	42-177	Spring Holder	12
4	HB-516-18-100	Hex Bolt $\frac{5}{16}$ - 18 x 1	12
5	HNTL-12-13	Lock Nut $\frac{1}{2}$ - 13	2
6	42-212	Castor Wheel Spacer	4
7	42-213	Axle Bearing	2
8	42-122	Rake Spring	12
9	HB-12-13-600	Hex Bolt $\frac{1}{2}$ - 13 x 6	2
10	HNTL-38-16	Lock Nut $\frac{3}{8}$ - 16	10
11	HMB-34-14	Machine Bushing $\frac{3}{4}$ x 14GA	2
12	HW-38	Flat Washer $\frac{3}{8}$	12
13	HNTL-516-18	Lock Nut $\frac{5}{16}$ - 18	12
14	42-289	Right Castor Wheel Bracket	1
	10-025	Flange Bushing (Part of 42-289)	2
	HG-14-28-180	Grease Fitting $\frac{1}{4}$ - 28 x 180° (Part of 42-289)	1
15	42-215	Short Spacer	2
16	42-214	Long Spacer	2
17	42-539	Lynch Pin $\frac{1}{4}$ "	2
18	HMB-34-10	Machine Bushing $\frac{3}{4}$ x 10GA	8
19	HB-38-16-100	Hex Bolt $\frac{3}{8}$ - 16 x 1	8
20	HB-38-16-125	Hex Bolt $\frac{3}{8}$ - 16 x 1 $\frac{1}{4}$	2
21	HHP-18	Bridge Pin $\frac{1}{8}$	3
22	HCP-12-200	Clevis Pin $\frac{1}{2}$ x 2	2
23	42-203	Attachment Lift Bar	1
24	HCP-58-250	Clevis Pin $\frac{5}{8}$ x 2 $\frac{1}{2}$	1
25	42-288	Left Castor Wheel Bracket	1
	10-025	Flange Bushing (Part of 42-288)	2
	HG-14-28-180	Grease Fitting $\frac{1}{4}$ - 28 x 180° (Part of 42-288)	1
26	42-343	Spring Bar	1

# 42-010 CONSTRUCTION LEVELING BLADE DRAWING

Center Attachment

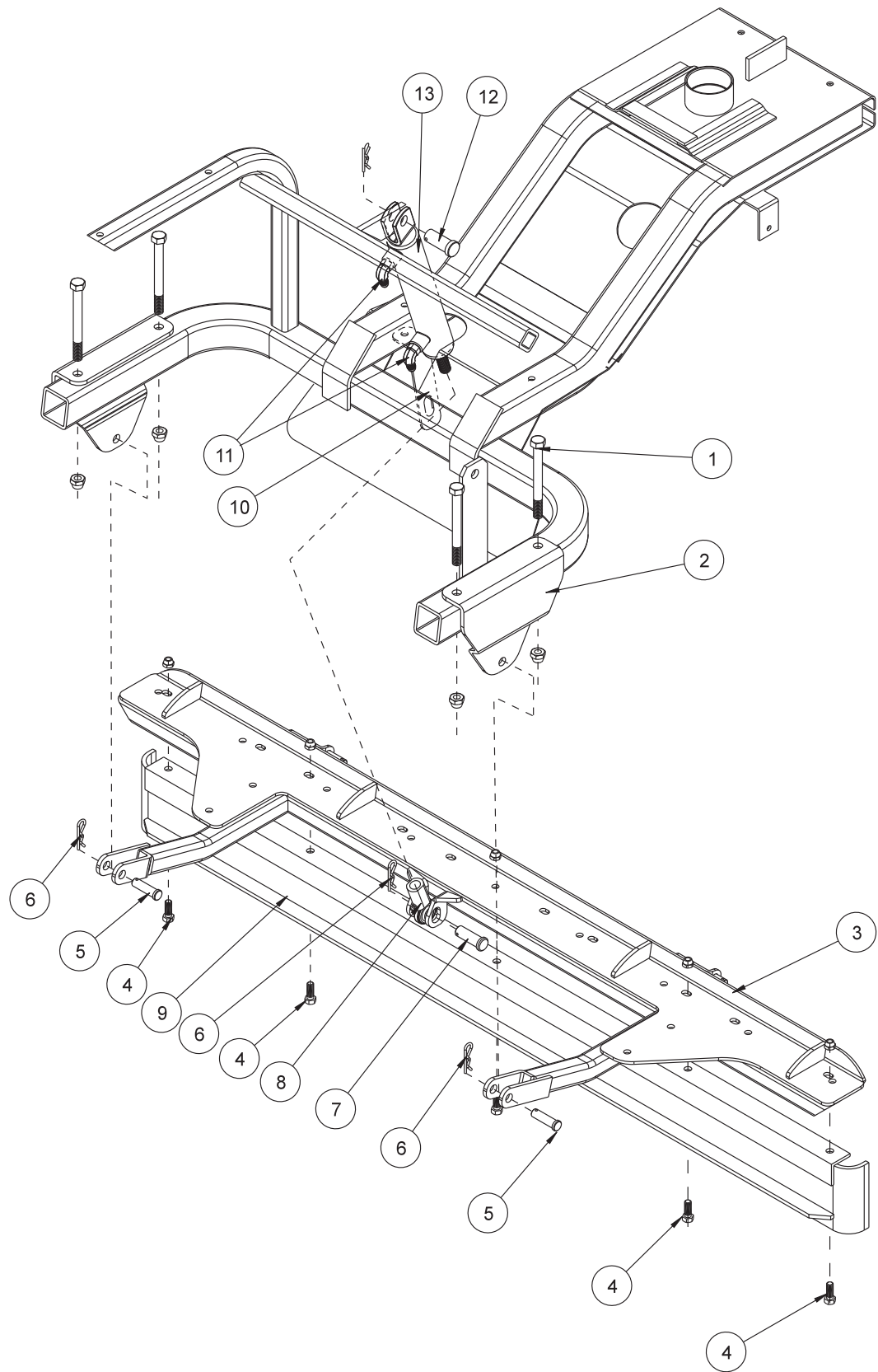

## 42-010 CONSTRUCTION LEVELING BLADE PARTS LIST

REF#	PART#	DESCRIPTION	QUANTITY
1	HB-12-13-500	Bolt $\frac{1}{2}$ - 13 x 5	4
	HNTL-12-13	Lock Nut $\frac{1}{2}$ - 13	4
2	42-015	Attachment Mount	2
*3	42-203	Attachment Lift	1
*4	HB-38-16-100	Bolt $\frac{3}{8}$ - 16 x 1	5
	HNTL-38-16	Lock Nut $\frac{3}{8}$ - 16	5
*5	HCP-12-200	Clevis Pin $\frac{1}{2}$ x 2	2
*6	HHP-18	Bridge Pin $\frac{1}{8}$	3
*7	HCP-58-250	Clevis Pin $\frac{5}{8}$ x $2\frac{1}{2}$	1
8	18-154	Rod End	1
*9	42-097	Leveling Blade	1
10	42-217	Cylinder Mount	1
11	18-168	90° Elbow	2
12	HCP-34-175	Clevis Pin $\frac{3}{4}$ - $1\frac{3}{4}$	1
13	10-135	Hydraulic Cylinder	1
*	42-010	Construction Leveling Blade (all other parts are reference only)	

## INSTALLATION INSTRUCTIONS

1. Remove the cylinder mount (Ref 10) from the machine.
2. Bolt leveling blade (Ref 9) to attachment lift (Ref 3) using five  $\frac{3}{8}$  - 16 x 1 bolts and five  $\frac{3}{8}$  - 16 lock nuts as shown on drawing.
3. Attach the attachment lift to attachment mount (Ref 3) using clevis pin and bridge pin (Ref 5 and 6).
4. Lift attachment lift up or extend cylinder so rod end (Ref 8) lines up with the holes on the center of the attachment lift. Use  $\frac{5}{8}$  x  $2\frac{1}{2}$  clevis pin and bridge pin (Ref 6 & 7) to fasten cylinder to cultivator.
5. Turn machine on and test for proper operation.



# 42-210 GRADER BLADE DRAWING

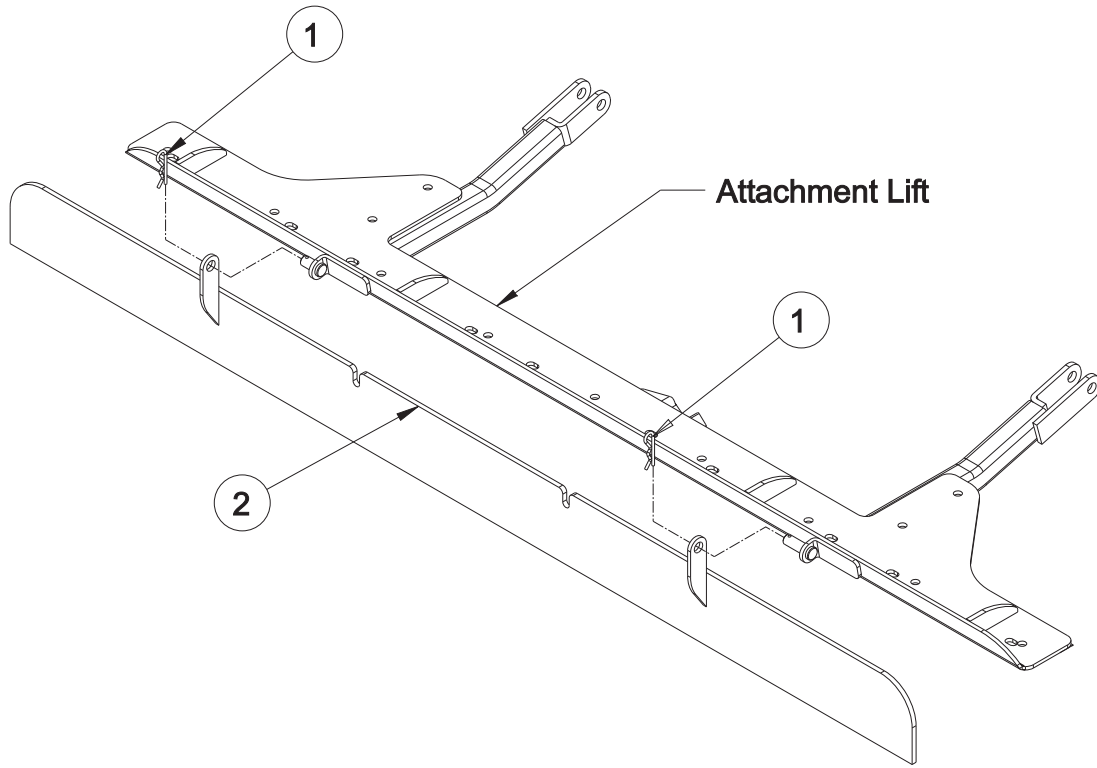

Center Attachment

# 42-210 GRADER BLADE MOUNT DRAWING

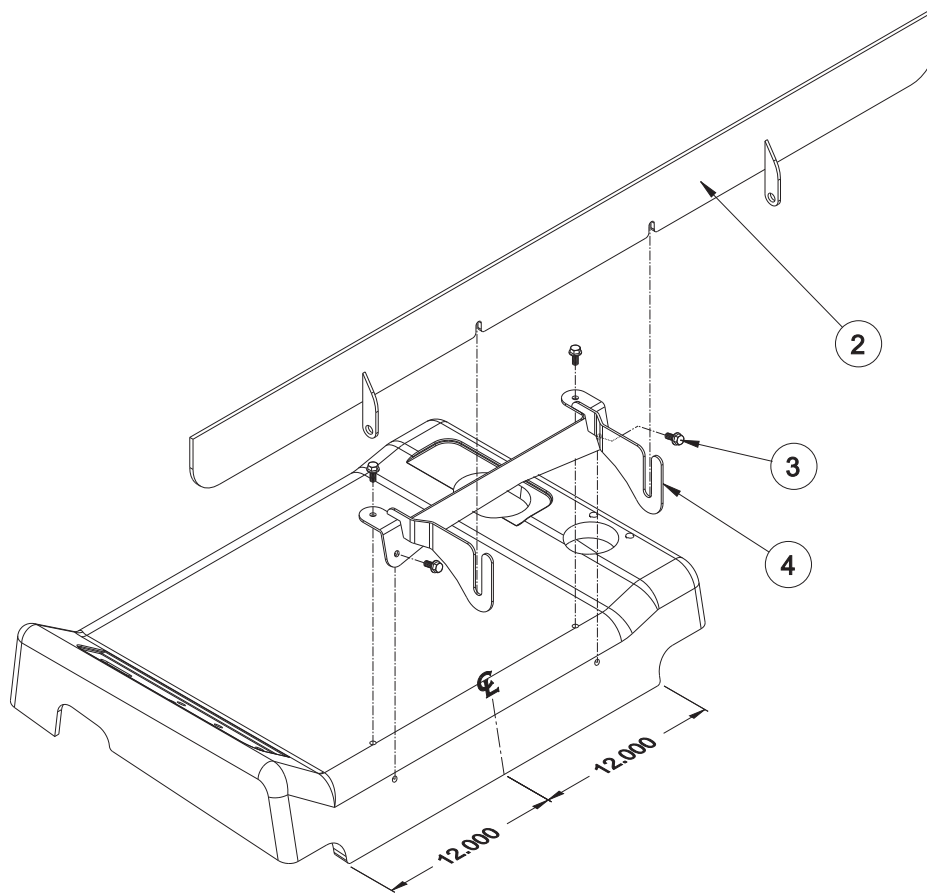

## 42-210 GRADER BLADE PARTS LIST

REF#	PART#	DESCRIPTION	QTY
1	HHP-18	Bridge Pin $\frac{1}{8}$	2
2	42-207	Grader Blade	1
3	HBFL-516-18-075	Flange Bolt, $\frac{5}{16}$ - 18 x $\frac{3}{4}$	4
	HNFL-516-18	Flange Whiz-Loc Nut, $\frac{5}{16}$ - 18 <i>(not illustrated)</i>	4
4	42-386	Grader Blade Mount	1

## 42-210 GRADER BLADE INSTALLATION INSTRUCTIONS

1. Install Grader Blade (Ref 2) onto Attachment Lift by sliding tabs onto clevis pins and secure with Bridge Pins (Ref 1).
2. Install Grader Blade Mount (Ref 4) on seat panel.
3. Position the Grader Blade Mount (Ref 4) to be centered on the rear of the Seat Panel as illustrated. Mark the hole locations on the Seat Panel. Using an  $\text{Ø}^{11/32}$  drill located the holes at the four marks made previously. The top two holes will be drilled through the fiberglass and the steel panel and the rear holes will be drilled through the fiberglass only.
4. Bolt the Grader Blade Mount (Ref 4) to the Seat Panel using the four  $\frac{5}{16}$  -18 Flange Bolts and Flange Nuts (Ref 3).
5. The Grader Blade Mount is used for the storage of the Grader Blade when not in use. To store, turn the Grader Blade to the position illustrated in the **Grader Blade Mount Drawing** and place in the Grader Blade Mount.
6. Turn machine on and test for proper operation.

# 42-178 INFIELD SCARIFIER WITH VERTICAL BLADES DRAWING

Center Attachment

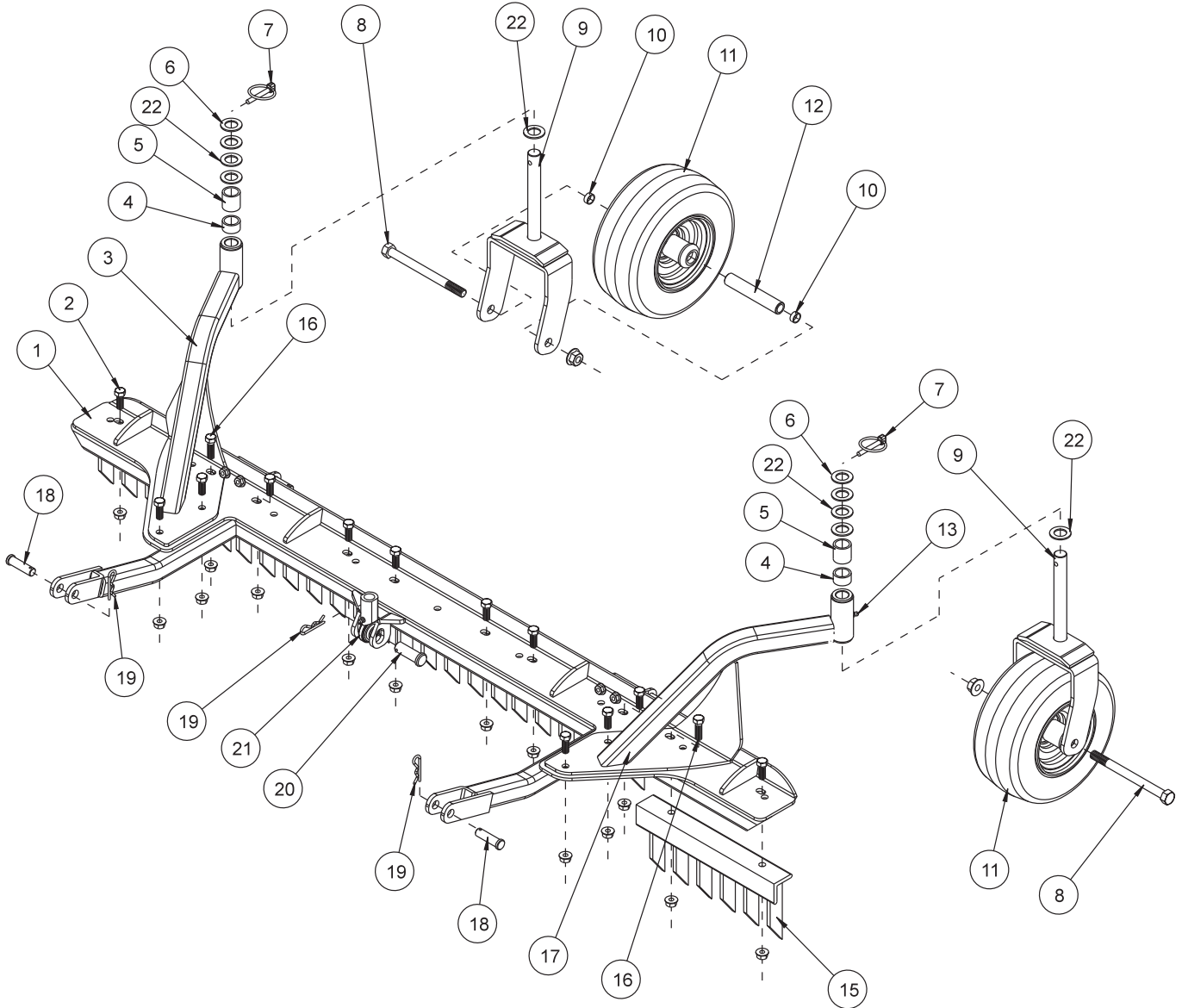

## 42-178 INFIELD SCARIFIER WITH VERTICAL BLADES PARTS LIST

REF#	PART#	DESCRIPTION	QUANTITY
1	42-203	Attachment Lift Assembly	1
2	HB-38-16-100	Bolt $\frac{3}{8}$ - 16 x 1	12
	HNTL-38-16	Lock Nut $\frac{3}{8}$ - 16	12
3	42-205	Left Castor Wheel Bracket	1
	10-025	Bushing (part of 42-205)	2
4	42-215	Short Spacer	2
5	42-214	Long Spacer	2
6	HMB-34-14	Machine Bushing $\frac{3}{4}$ x 14GA	2
7	42-539	Lynch Pin $\frac{5}{16}$	2
8	HB-12-13-600	Bolt $\frac{1}{2}$ -13 x 6	2
	HNTL-12-13	Lock Nut $\frac{1}{2}$ - 13	2
9	42-204	Castor Fork	2
10	42-212	Castor Wheel Spacer	4
11	42-202	Tire and Wheel	2
	42-202-01	Tire 9 x 3.5 x 4 Ply	2
	42-202-02	Wheel	2
	42-202-03	Cap	2
	42-202-04	Bearing	2
	42-202-05	Seal	2
12	42-213	Axle Bearing	2
13	HG-14-28-180	Grease Fitting $\frac{1}{4}$ - 28 x 180° (part of 42-205 and 42-206)	2
15	26-042	Tine Segment	5
16	HB-38-16-125	Bolt $\frac{3}{8}$ - 16 x $1\frac{1}{4}$	2
	HNTL-38-16	Lock Nut $\frac{3}{8}$ - 16	2
17	42-206	Right Castor Wheel Bracket	1
	10-025	Bushing (part of 42-205)	2
18	HCP-12-200	Clevis Pin $\frac{1}{2}$ x 2	2
19	HHP-18	Bridge Pin $\frac{1}{8}$	3
20	HCP-58-250	Clevis Pin $\frac{5}{8}$ x $2\frac{1}{2}$	1
21	18-154	Rod End (part of machine)	1
22	HMB-34-10	Machine Bushing $\frac{3}{4}$ x 10GA	8

# 42-178 SCARIFIER MOUNTING DRAWING

Center Attachment

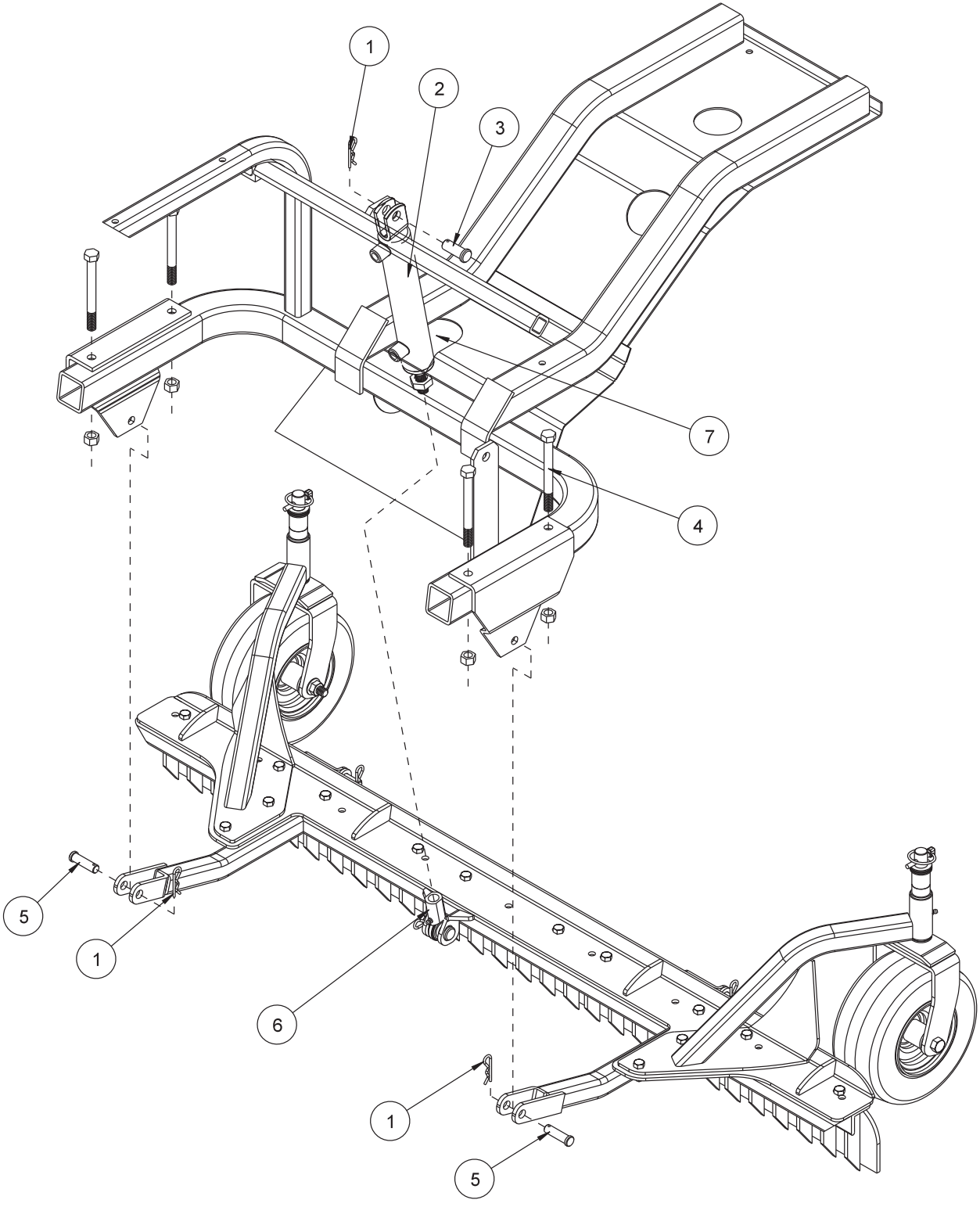

## 42-178 SCARIFIER MOUNTING PARTS LIST

REF#	PART#	DESCRIPTION	QUANTITY
1	HHP-18	Bridge Pin $\frac{1}{8}$	3
2	10-135	Hydraulic Cylinder (part of machine)	1
3	HCP-58-175	Clevis Pin $\frac{5}{8} \times 1\frac{3}{4}$	1
4	HB-12-13-500	Bolt $\frac{1}{2}$ - 13 x 5	4
	HNTL-12-13	Lock Nut $\frac{1}{2}$ - 13	4
5	HCP-12-200	Clevis Pin $\frac{1}{2}$ - 2	2
6	18-154	Rod End (part of machine)	1
7	42-217	Cylinder Mount (part of machine)	1

## INSTALLATION INSTRUCTIONS

1. Assemble the Scarifier as shown on previous page.
2. Remove the rod end (Ref 6) on the hydraulic cylinder (Ref 2) from the cylinder mount (Ref 7). Remove the cylinder mount (Ref 7) from the machine.
- \*3. Place the handle and linkage onto the empty linkage port of the two bank valve on the machine.
4. Slide the Scarifier under the machine lining up the hydraulic cylinder and the center of the attachment lift assembly.
5. Extend hydraulic cylinder all the way down by pushing the lever forward.
6. Mount the rod end of the cylinder onto the attachment lift assembly and secure with a clevis pin and bridge pin.
7. Attach the arms on the attachment lift to the attachment mount on the machine and secure with clevis pin and bridge pin.
8. Turn machine on and test for proper operation.
9. Adjust castor wheels by placing the short or long spacer on the castor wheel fork before placing the castor wheel assembly into the castor wheel brackets. Be sure both castor wheels are adjusted to the same height.

\* For machines prior to serial numbers 4500 (3WD) and 12500 (2WD).

# 42-179 INFIELD SCARIFIER WITH CHISEL BLADES DRAWING

Center Attachment

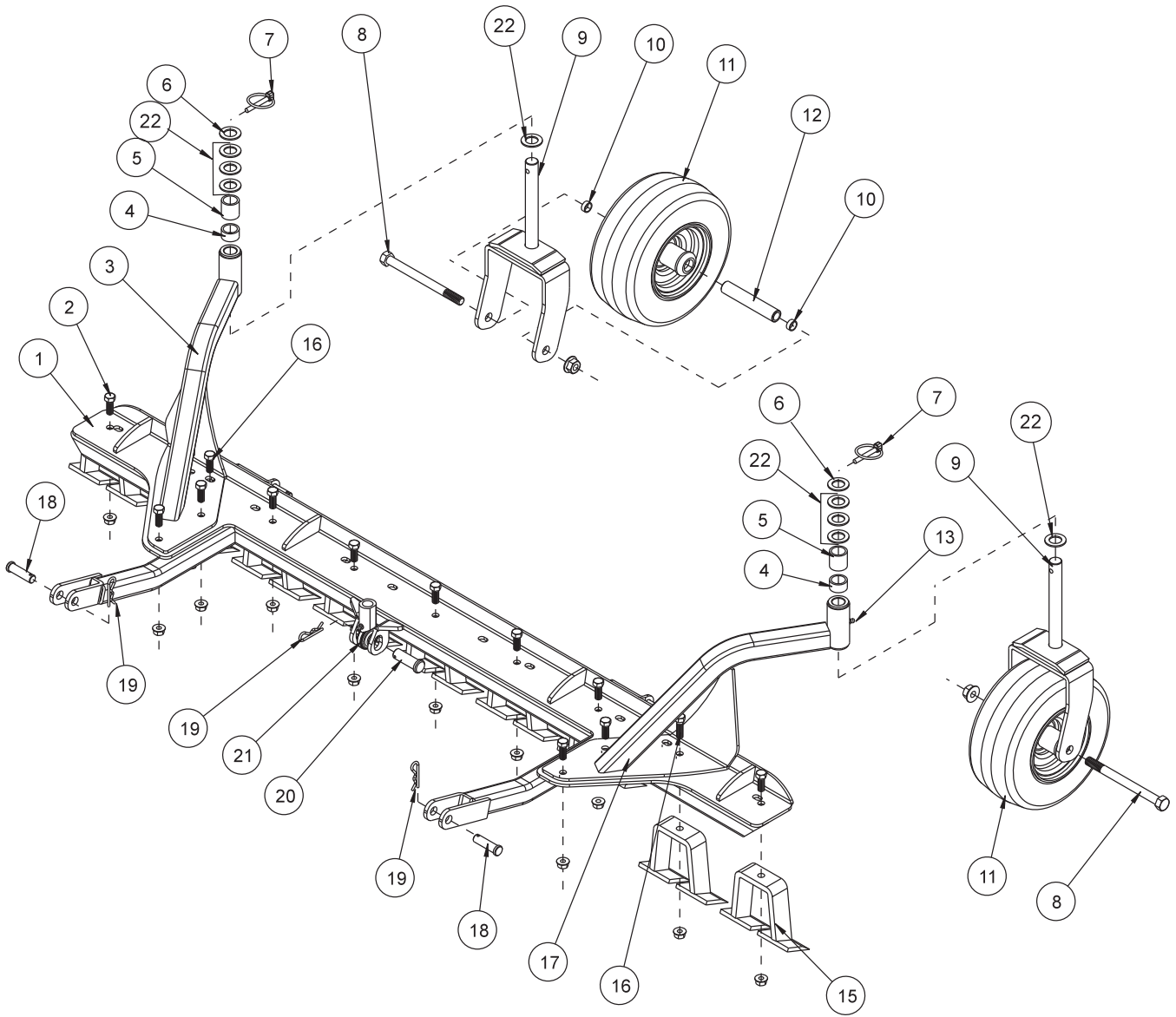

## 42-179 INFIELD SCARIFIER WITH CHISEL BLADES PARTS LIST

REF#	PART#	DESCRIPTION	QUANTITY
1	42-203	Attachment Lift Assembly	1
2	HB-38-16-125	Bolt $\frac{3}{8}$ - 16 x $1\frac{1}{4}$	11
	HNTL-38-16	Lock Nut $\frac{3}{8}$ - 16	11
3	42-205	Left Castor Wheel Bracket	1
	10-025	Bushing (part of 42-205)	2
4	42-215	Short Spacer	2
5	42-214	Long Spacer	2
6	HMB-34-14	Machine Bushing $\frac{3}{4}$ x 14GA	2
7	42-539	Lynch Pin $\frac{5}{16}$	2
8	HB-12-13-600	Bolt $\frac{1}{2}$ -13 x 6	2
	HNTL-12-13	Lock Nut $\frac{1}{2}$ - 13	2
9	42-204	Castor Fork	2
10	42-212	Castor Wheel Spacer	4
11	42-202	Tire and Wheel	2
	42-202-01	Tire 9 x 3.5 x 4 Ply	2
	42-202-02	Wheel	2
	42-202-03	Cap	2
	42-202-04	Bearing	2
	42-202-05	Seal	2
12	42-213	Axle Bearing	2
13	HG-14-28-180	Grease Fitting $\frac{1}{4}$ - 28 x 180° (part of 42-205 and 42-206)	2
15	13-114	Digger Blade	9
16	HB-38-16-150	Bolt $\frac{3}{8}$ - 16 x $1\frac{1}{2}$	2
	HNTL-38-16	Lock Nut $\frac{3}{8}$ - 16	2
17	42-206	Right Castor Wheel Bracket	1
	10-025	Bushing (part of 42-205)	2
18	HCP-12-200	Clevis Pin $\frac{1}{2}$ x 2	2
19	HHP-18	Bridge Pin $\frac{1}{8}$	3
20	HCP-58-250	Clevis Pin $\frac{5}{8}$ x $2\frac{1}{2}$	1
21	18-154	Rod End (part of machine)	1
22	HMB-34-10	Machine Bushing $\frac{3}{4}$ x 10GA	8



# 42-179 SCARIFIER MOUNTING DRAWING

Center Attachment

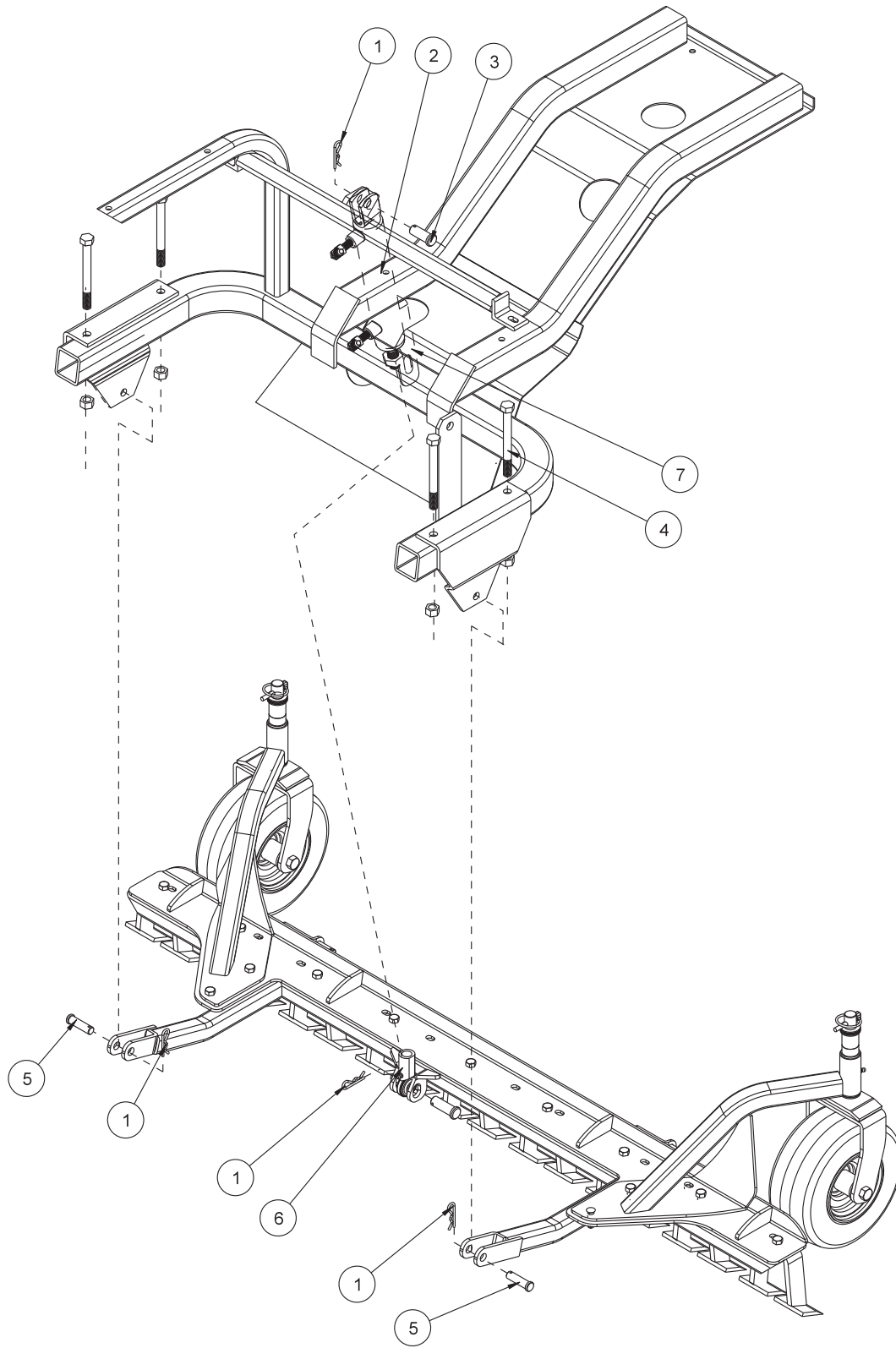

## 42-179 SCARIFIER MOUNTING PARTS LIST

REF#	PART#	DESCRIPTION	QUANTITY
1	HHP-18	Bridge Pin $\frac{1}{8}$	3
2	10-135	Hydraulic Cylinder (part of machine)	1
3	HCP-58-175	Clevis Pin $\frac{5}{8} \times 1\frac{3}{4}$	1
4	HB-12-13-500	Bolt $\frac{1}{2}$ - 13 x 5	4
	HNTL-12-13	Lock Nut $\frac{1}{2}$ - 13	4
5	HCP-12-200	Clevis Pin $\frac{1}{2}$ - 2	2
6	18-154	Rod End (part of machine)	1
7	42-217	Cylinder Mount (part of machine)	1

## INSTALLATION INSTRUCTIONS

1. Assemble the Scarifier as shown on previous page.
2. Remove the rod end (Ref 6) on the hydraulic cylinder (Ref 2) from the cylinder mount (Ref 7). Remove the cylinder mount (Ref 7) from the machine.
- \*3. Place the handle and linkage onto the empty linkage port of the two bank valve on the machine.
4. Slide the Scarifier under the machine lining up the hydraulic cylinder and the center of the attachment lift assembly.
5. Extend hydraulic cylinder all the way down by pushing the lever forward.
6. Mount the rod end of the cylinder onto the attachment lift assembly and secure with a clevis pin and bridge pin.
7. Attach the arms on the attachment lift to the attachment mount on the machine and secure with clevis pin and bridge pin.
8. Turn machine on and test for proper operation.
9. Adjust castor wheels by placing the short or long spacer on the castor wheel fork before placing the castor wheel assembly into the castor wheel brackets. Be sure both castor wheels are adjusted to the same height.

\* For machines prior to serial numbers 4500 (3WD) and 12500 (2WD).

# 42-285 SCARIFIER WITH VERTICAL BLADES

Center Attachment

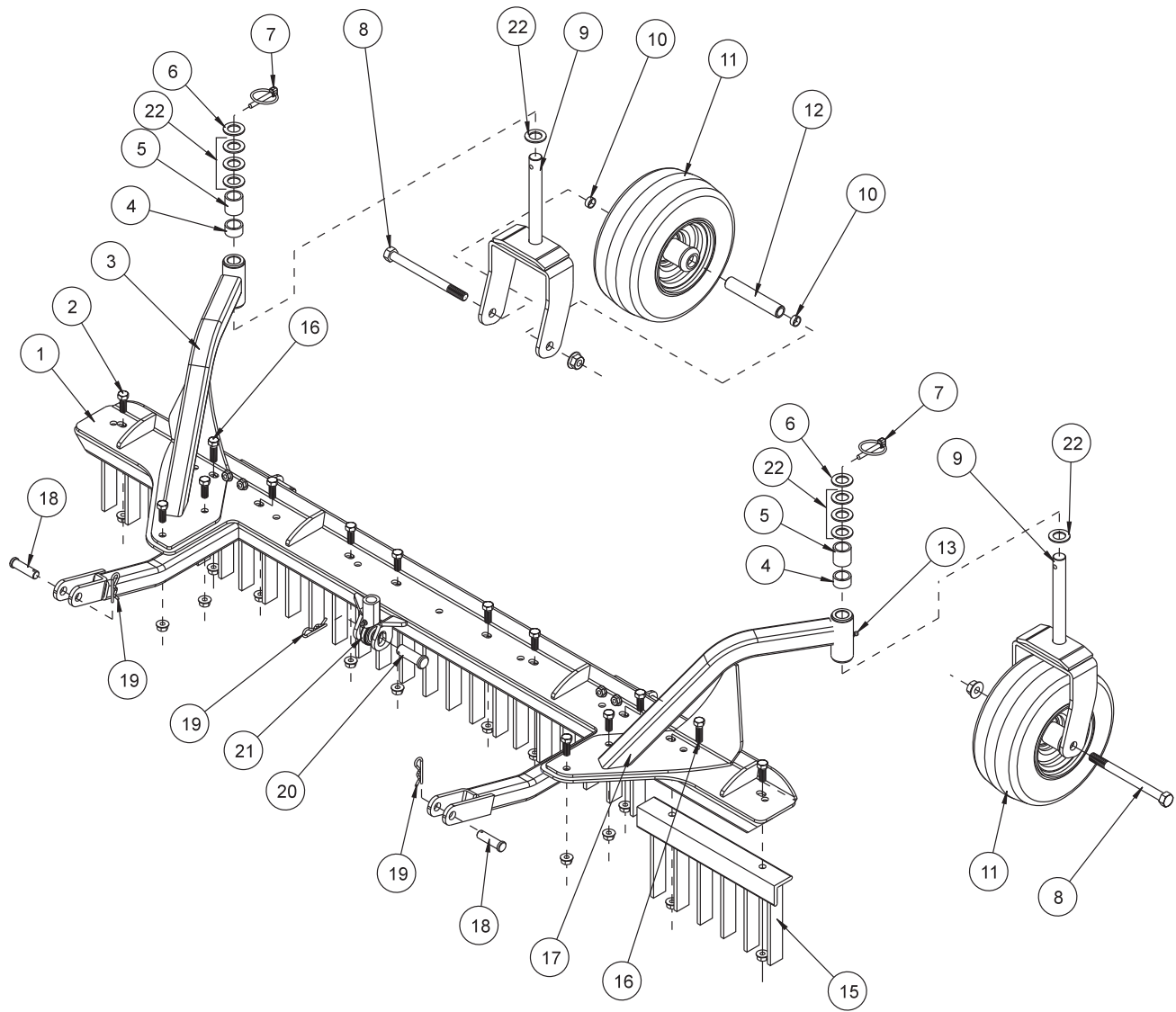

## 42-285 SCARIFIER WITH VERTICAL BLADES PARTS LIST

REF#	PART#	DESCRIPTION	QUANTITY
1	42-203	Attachment Lift Assembly	1
2	HB-38-16-100	Bolt $\frac{3}{8}$ - 16 x 1	12
	HNTL-38-16	Lock Nut $\frac{3}{8}$ - 16	12
3	42-288	Left Castor Wheel Bracket	1
	10-025	Bushing (part of 42-288)	2
4	42-215	Short Spacer	2
5	42-214	Long Spacer	2
6	HMB-34-14	Machine Bushing $\frac{3}{4}$ x 14GA	2
7	42-539	Lynch Pin $\frac{5}{16}$	2
8	HB-12-13-600	Bolt $\frac{1}{2}$ -13 x 6	2
	HNTL-12-13	Lock Nut $\frac{1}{2}$ - 13	2
9	42-204	Castor Fork	2
10	42-212	Castor Wheel Spacer	4
11	42-202	Tire and Wheel	2
	42-202-01	Tire 9 x 3.5 x 4 Ply	2
	42-202-02	Wheel	2
	42-202-03	Cap	4
	42-202-04	Bearing	4
	42-202-05	Seal	4
12	42-213	Axle Bearing	2
13	HG-14-28-180	Grease Fitting $\frac{1}{4}$ - 28 x 180° (part of 42-288 and 42-289)	2
15	42-241	Tine Segment	5
16	HB-38-16-125	Bolt $\frac{3}{8}$ - 16 x $1\frac{1}{4}$	2
	HNTL-38-16	Lock Nut $\frac{3}{8}$ - 16	2
17	42-289	Right Castor Wheel Bracket	1
	10-025	Bushing (part of 42-289)	2
18	HCP-12-175	Clevis Pin $\frac{1}{2}$ x $1\frac{3}{4}$	2
19	HHP-18	Bridge Pin $\frac{1}{8}$	3
20	HCP-58-250	Clevis Pin $\frac{5}{8}$ x $2\frac{1}{2}$	1
21	18-154	Rod End (part of machine)	1
22	HMB-34-10	Machine Bushing $\frac{3}{4}$ x 10GA	8

Center Attachment

# 42-285 SCARIFIER WITH VERTICAL BLADES MOUNTING DRAWING

Center Attachment

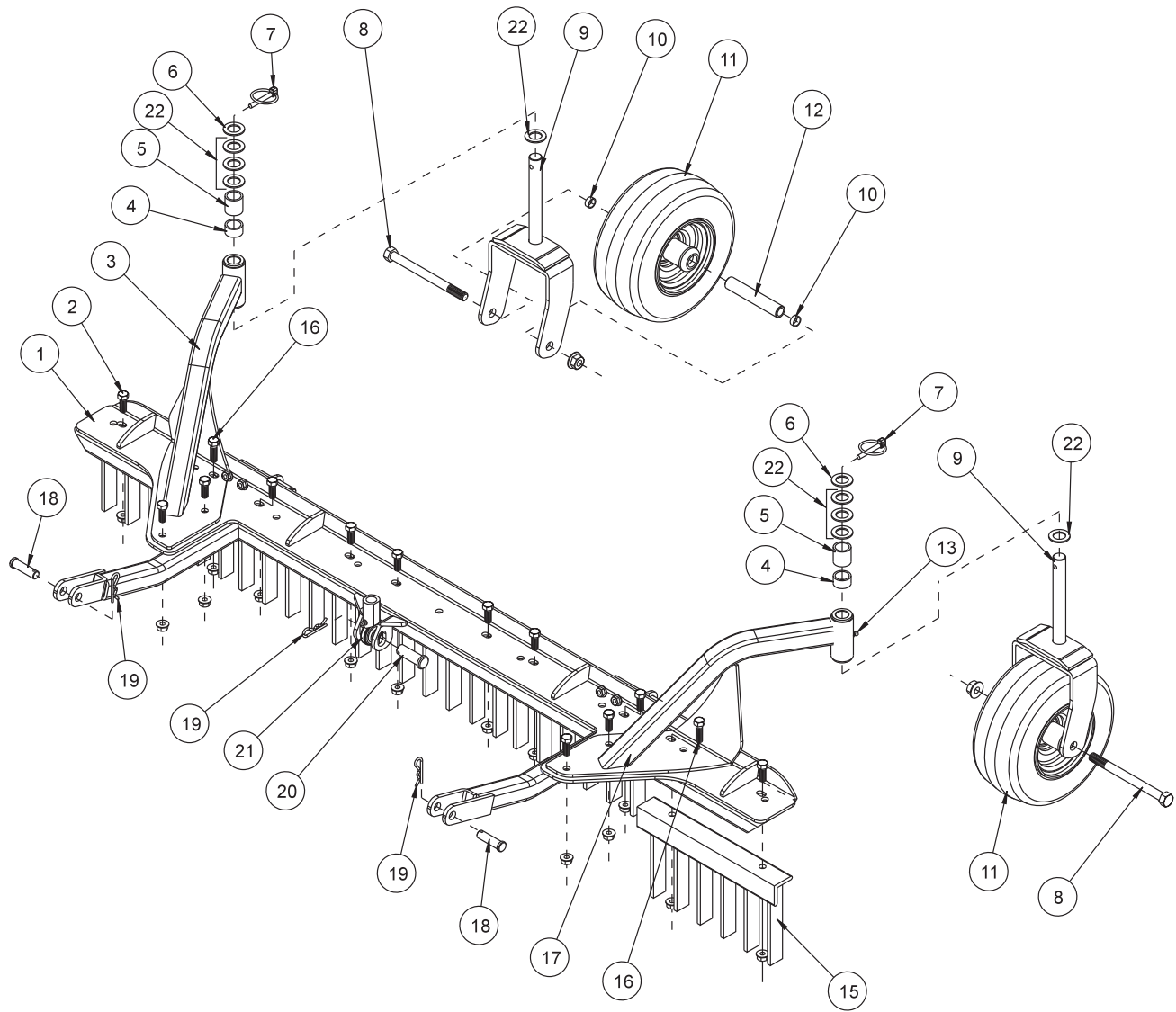

## 42-285 SCARIFIER WITH VERTICAL BLADES MOUNTING PARTS LIST

REF#	PART#	DESCRIPTION	QUANTITY
1	HHP-18	Bridge Pin $\frac{1}{8}$	3
2		Hydraulic Cylinder (part of machine)	1
3	HCP-58-175	Clevis Pin $\frac{5}{8} \times 1\frac{3}{4}$	1
4	HB-12-13-500	Bolt $\frac{1}{2}$ - 13 x 5 (part of machine)	4
	HNTL-12-13	Lock Nut $\frac{1}{2}$ - 13 (part of machine)	4
5	HCP-12-175	Clevis Pin $\frac{1}{2}$ - $1\frac{3}{4}$	2
6	18-154	Rod End (part of machine)	1
7	42-217	Cylinder Mount (temporary part of machine)	1

## INSTALLATION INSTRUCTIONS

1. Assemble the Scarifier as shown on previous page.
2. Disconnect the rod end (Ref 6) on the hydraulic cylinder (Ref 2) from the cylinder mount (Ref 7). Remove the cylinder mount (Ref 7) from the machine.
3. Place the handle and linkage onto the empty linkage port of the two bank valve on the machine.
4. Slide the Scarifier under the machine lining up the hydraulic cylinder and the center of the attachment lift assembly.
5. Extend hydraulic cylinder all the way down by pushing the lever forward.
6. Mount the rod end of the cylinder onto the attachment lift assembly and secure with a clevis pin and bridge pin.
7. Attach the arms on the attachment lift to the attachment mount on the machine and secure with clevis pin and bridge pin.
8. Turn machine on and test for proper operation.
9. Adjust castor wheels by placing the short or long spacer on the castor wheel fork before placing the castor wheel assembly into the castor wheel brackets. Be sure both castor wheels are adjusted to the same height.

# ACCESSORIES

Plows .....	A
13-731 Single Bank Valve .....	2
43-003 Hydraulic Sand Plow .....	4
42-011 Sand Plow(Steel & Aluminum) .....	8
42-136 60" Sand Plow .....	10
42-460 40" Angle Plow .....	12
42-490 60" Angle Plow .....	14
42-315 Light Kit .....	16
Belly Attachments .....	B
42-223 Adjustable Disc Edger .....	2
42-750 Cart Path & Sidewalk Edger .....	4
42-130 Wedd Cultivator .....	6
42-008 Sand Cultivator .....	8
42-340 Sand Cultivator w/ Spring Tine .....	10
42-341 Sand Cultivatore w/ Castor Wheels .....	12
42-010 Construction Leveling Blade .....	14
42-210 Grader Blade Kit .....	16
42-178 Infield Scarifier(vertical blades) .....	18
42-179 Infield Scarifier(chisel blades) .....	22
42-285 Scarifier w/ Vertical Blades .....	26
<b>Rear Attachments .....</b>	<b>C</b>
<b>42-391Q 72" Pro-Brush Tournament Rake .....</b>	<b>2</b>
<b>43-392Q 84" Pro-Brush Tournament Rake .....</b>	<b>6</b>
<b>42-130Q 84" Mild Steel Rake .....</b>	<b>10</b>
<b>42-132Q 72" Mild Steel Rake .....</b>	<b>14</b>
<b>13-438Q Rake with Finishing Blades .....</b>	<b>18</b>
<b>13-298Q Fan Rake .....</b>	<b>20</b>
<b>26-007Q Professional Field Finisher .....</b>	<b>22</b>
<b>43-002Q Flex Action Field Finisher w/ Brush .....</b>	<b>24</b>
<b>26-008Q Flex Action Field Finisher .....</b>	<b>28</b>
<b>42-586Q Green Star RBS Main Frame .....</b>	<b>30</b>
<b>42-581 Green Star RBS Roller .....</b>	<b>32</b>
<b>42-585 Green Star RBS Brush .....</b>	<b>34</b>
<b>42-582 Green Star RBS Spiker .....</b>	<b>36</b>
<b>Warranty .....</b>	<b>Inside Back Cover</b>

Front Attachment

Center Attachment

Rear Attachment

# 42-3910 72"(183CM) ProBRUSH TOURNAMENT RAKE DRAWING

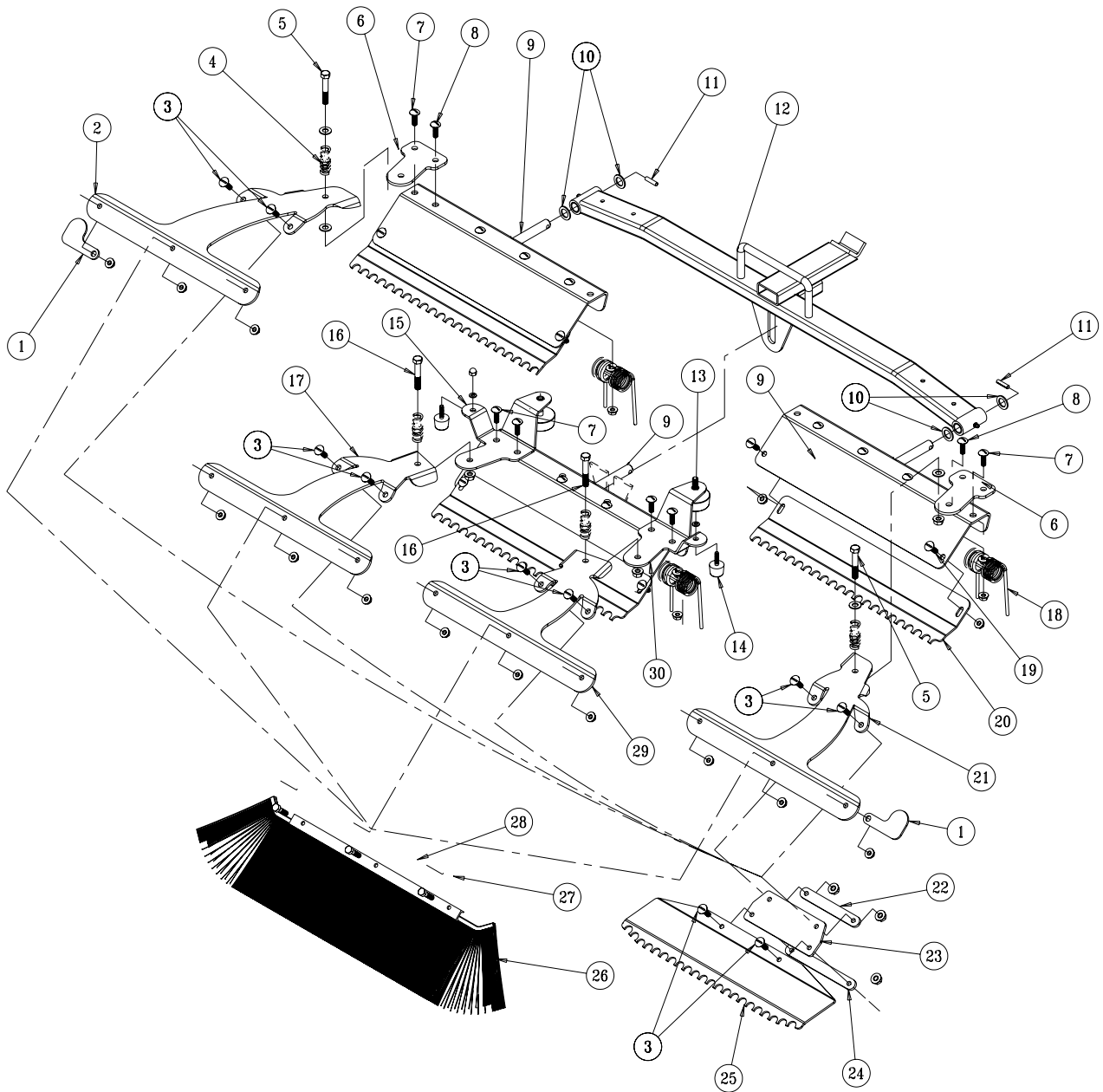

Rear Attachment





## 42-391Q 72"(183CM) PROBRUSH TOURNAMENT RAKE PARTS LIST

REF#	PART#	DESCRIPTION	QUANTITY
1	42-489	Tip Guard	2
2	42-397	Outside Brush Arm, LH	1
3	HSTP-516-18-100	Phillip Truss Head Screw, $\frac{5}{16}$ - 18 x 1	16
	HNFL-516-18	Flange Whiz-Loc Nut, $\frac{5}{16}$ - 18	16
4	11-055	Compression Spring	4
5	HB-38-16-250	Hex Bolt, $\frac{3}{8}$ - 16 x 2 $\frac{1}{2}$	2
	HW-38	Flat Washer, $\frac{3}{8}$	2
	HNTL-38-16	Lock Nut, $\frac{3}{8}$ - 16	2
6	42-396	Outside Brush Arm Mount	2
7	HSTP-516-18-100	Phillips Truss Head Screw, $\frac{5}{16}$ - 18 x 1	4
	HNFL-516-18	Flange Whiz-Loc Nut, $\frac{5}{16}$ - 18	4
8	HSTP-516-18-125	Phillips Truss Head Screw, $\frac{5}{16}$ - 18 x 1 $\frac{1}{4}$	12
	HNFL-516-18	Flange Whiz-Loc Nut, $\frac{5}{16}$ - 18	12
9	42-140	Outside Rake	3
10	HMB-58-14	Machine Bushing $\frac{5}{8}$ x 14GA	4
11	HRP-14-100	Roll Pin $\frac{1}{4}$ x 1	2
12	43-154	Draw Bar	1
13	50-081	Rubber Bumper	2
14	15-013	Rubber Bumper	2
	HNC-14-20	Cap Nut, $\frac{1}{4}$ - 20	2
	HWL-14	Lock Washer, $\frac{1}{4}$	2
15	42-399	Brush Arm Mount, LH	1
16	HB-38-16-250	Hex Bolt, $\frac{3}{8}$ - 16 x 2 $\frac{1}{2}$	2
	HNTL-38-16	Lock Nut, $\frac{3}{8}$ - 16	2
17	42-454	Inside Brush Arm, LH	1
18	42-122	Rake Spring	12
	42-177	Spring Holder	12
19	HSTP-516-18-075	Phillip Truss Head Screw, $\frac{5}{16}$ - 18 x $\frac{3}{4}$	6
	HNFL-516-18	Flange Whiz-Loc Nut $\frac{5}{16}$ - 18	6
20	42-171	Groomer Blades	3
21	42-393	Outside Brush Arm, RH	1
22	42-105	Top Strap	4
23	42-107	Matting	4
24	42-106	Bottom Strap	4
25	42-170	Finishing Blades	4
26	42-466	Brush, 21"	4
27	42-465	Brush Clamp	4
28	HB-516-18-125	Hex Bolt, $\frac{5}{16}$ - 18 x 1 $\frac{1}{4}$	12
	HNFL-516-18	Flange Whiz-Loc Nut $\frac{5}{16}$ - 18	12
29	42-453	Inside Brush Arm, RH	1
30	42-398	Brush Arm Mount, RH	1

42-3910 72"(183CM) ProBRUSH TOURNAMENT RAKE DRAWING

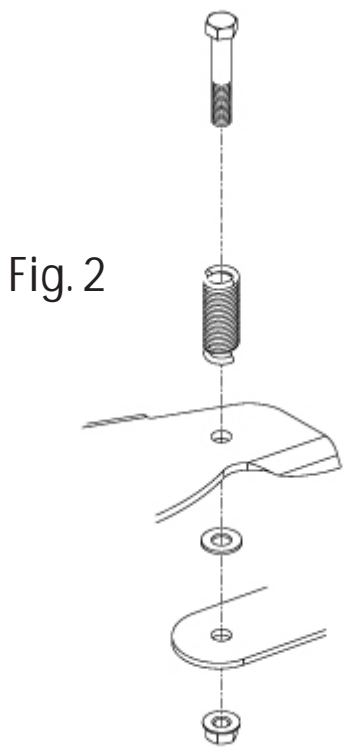
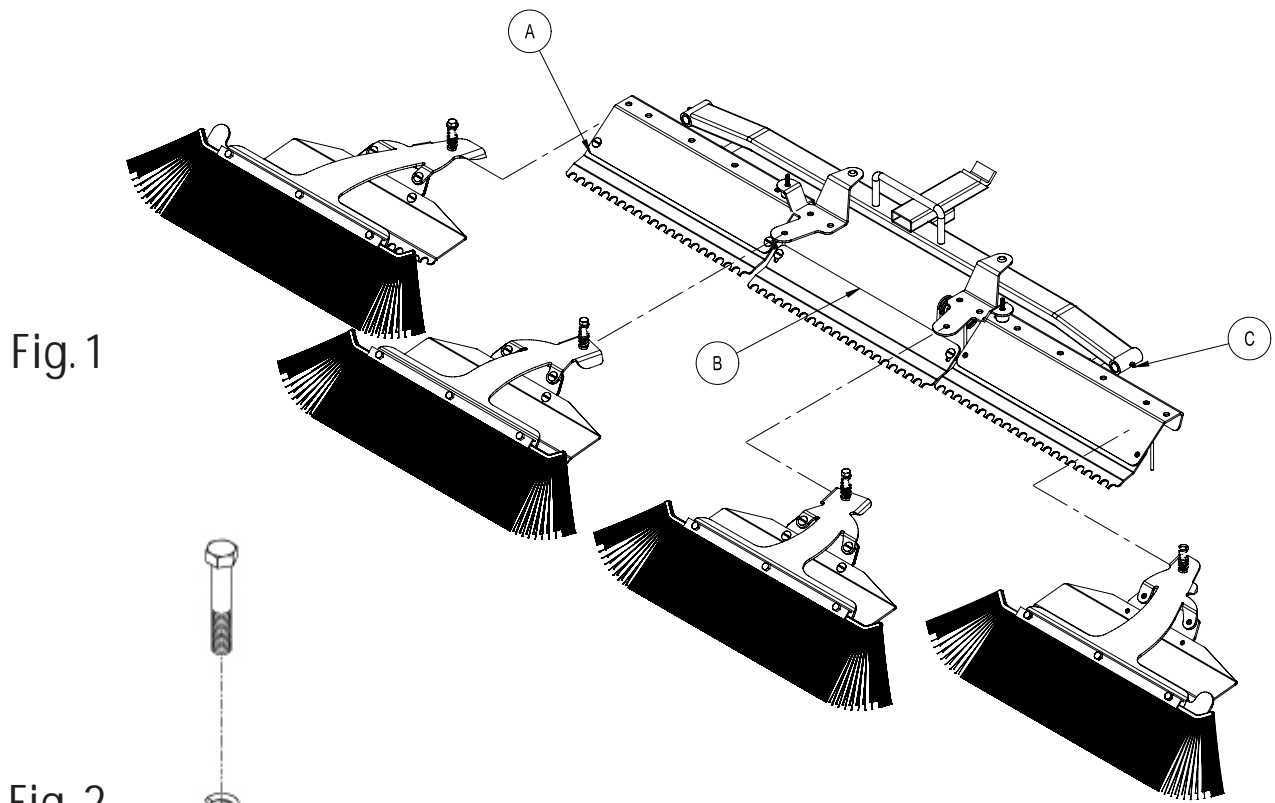

Fig. 3

Rear Attachment



## PROBRUSH TOURNAMENT RAKE ASSEMBLY INSTRUCTIONS

Your PROBRUSH TOURNAMENT RAKE comes mostly assembled.

1. Before assembly please note the two Brush/Finish Blade Assemblies (Refs A & C in Fig.1) that are mounted on the outside (RH & LH) have flat washers that are between the Brush Arms (Refs 2 & 21) and the Brush Arm Mount (Ref 6).
2. Also please note the placement of the Brush/Finish Blade Assemblies as illustrated in Fig 1. They must be mounted as illustrated to work as intended.
3. Begin assembling your PROBRUSH TOURNAMENT RAKE by inserting the Outside and Center Groomer Blade Assemblies (Refs A, B & C in Fig.1) in their locations as illustrated. Secure the Outside Assemblies with the ¼" Pin (Ref 11) and the Center Assembly with the ¼" x 1¾" Bolt and Lock Nut (Ref 13).
4. Mount the Brush/Finish Blade Assemblies to the Brush Arm Mounts (Refs 6, 30 & 15) as illustrated using the ¾" x 2½" Bolts and Lock Nuts. Assemble with the Springs (Ref 4) as shown in Fig. 2. Please note that the ¾" Flat Washers are used only on the Outside Assemblies. Secure when assembled.
5. Mount your PROBRUSH TOURNAMENT RAKE to the trap rake quick hitch. Position the Rake so it is centered and equal distance away from the right and left hand tires (2-3 inches). Fig. 4. Once positioned, set the Adjustment Screws on the Hitch so they touch the trap rake hitch. Fig. 5.
6. Run machine and test for operation of the Rake by raising and lowering the assembly and with rake down turn sharp corners in both directions to ensure rake is not contacting the tires. Test Rake in sand to ensure tire tracks are covered when turning sharp corners. If the tire tracks are not covered by the Rake, turn the Adjustment Screws on the Rake Hitch so the rake comes closer to the tires when turning. For reference see Fig. 4 and 5 below.

### NOTE:

The Outside Brush/Finish Blade Assemblies may be rotated 180° for transport and for working in narrow areas, as illustrated in Fig.3 on the facing page.

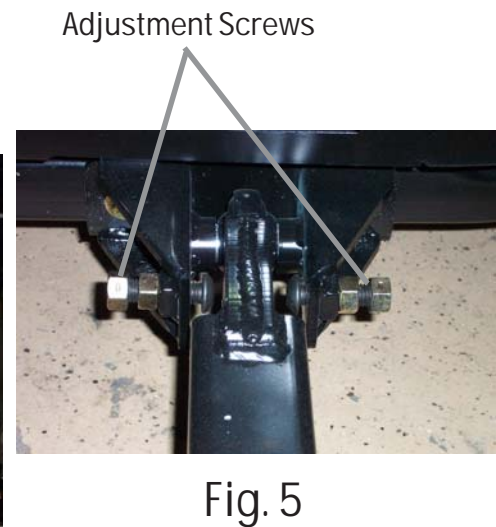

# 42-392Q 84"(213CM) PROBRUSH TOURNAMENT RAKE DRAWING

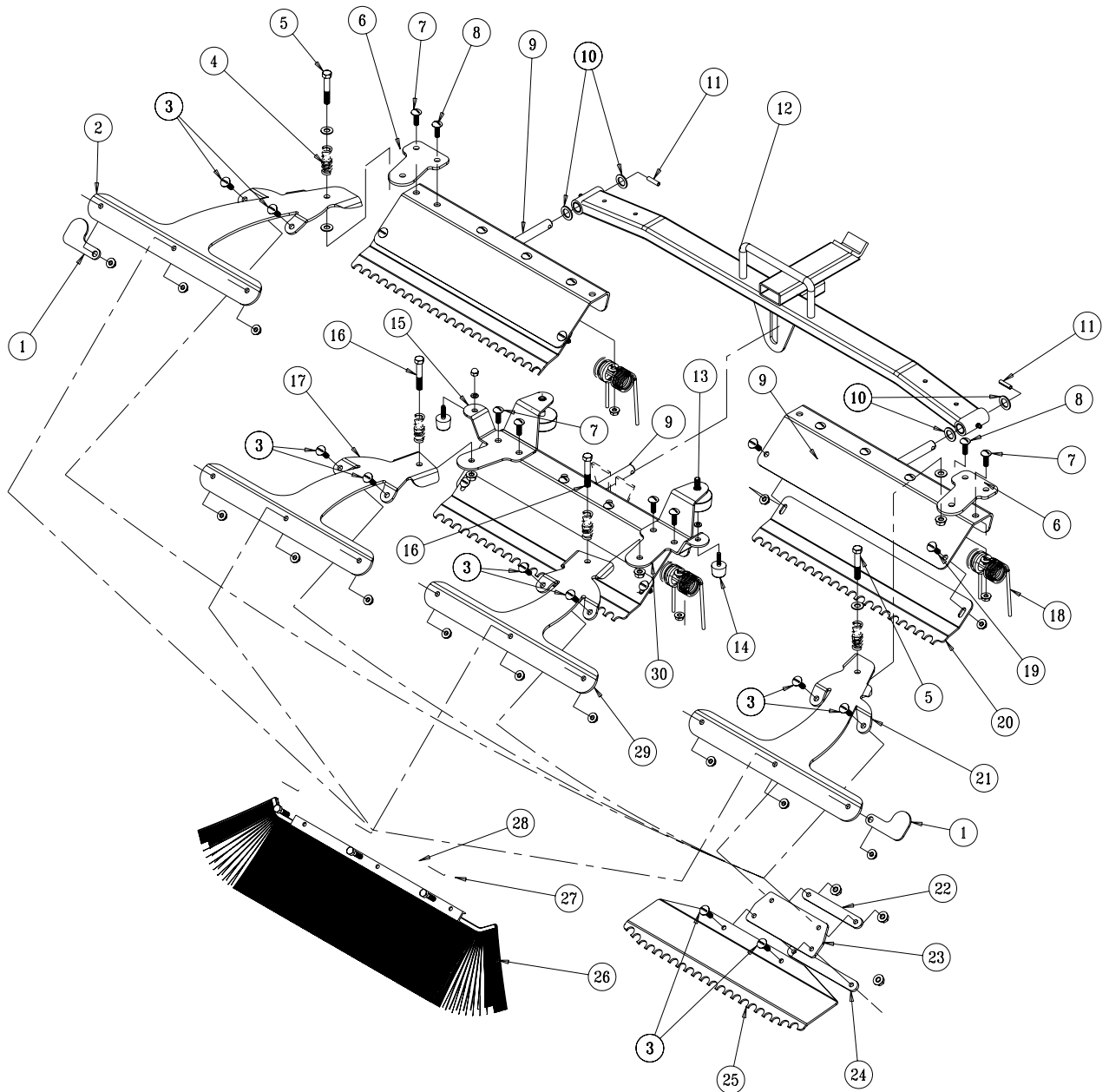

Rear Attachment



## 42-392Q 84"(213CM) PROBRUSH TOURNAMENT RAKE PARTS LIST

REF#	PART#	DESCRIPTION	QUANTITY
1	42-489	Tip Guard	2
2	42-397	Outside Brush Arm, LH	1
3	HSTP-516-18-100	Phillip Truss Head Screw, $\frac{5}{16}$ - 18 x 1	16
	HNFL-516-18	Flange Whiz-Loc Nut, $\frac{5}{16}$ - 18	16
4	11-055	Compression Spring	4
5	HB-38-16-250	Hex Bolt, $\frac{3}{8}$ - 16 x 2 $\frac{1}{2}$	2
	HW-38	Flat Washer, $\frac{3}{8}$	2
	HNTL-38-16	Lock Nut, $\frac{3}{8}$ - 16	2
6	42-396	Outside Brush Arm Mount	2
7	HSTP-516-18-100	Phillips Truss Head Screw, $\frac{5}{16}$ - 18 x 1	4
	HNFL-516-18	Flange Whiz-Loc Nut, $\frac{5}{16}$ - 18	4
8	HSTP-516-18-125	Phillips Truss Head Screw, $\frac{5}{16}$ - 18 x 1 $\frac{1}{4}$	12
	HNFL-516-18	Flange Whiz-Loc Nut, $\frac{5}{16}$ - 18	12
9	42-102	84" Outside Rake	3
10	HMB-58-14	Machine Bushing $\frac{5}{8}$ x 14GA	4
11	HRP-14-100	Roll Pin $\frac{1}{4}$ x 1	2
12	43-144	84" Draw Bar	1
13	50-081	Rubber Bumper	2
14	15-013	Rubber Bumper	2
	HNC-14-20	Cap Nut, $\frac{1}{4}$ - 20	2
	HWL-14	Lock Washer, $\frac{1}{4}$	2
15	42-399	Brush Arm Mount, LH	1
16	HB-38-16-250	Hex Bolt, $\frac{3}{8}$ - 16 x 2 $\frac{1}{2}$	2
	HNTL-38-16	Lock Nut, $\frac{3}{8}$ - 16	2
17	42-454	Inside Brush Arm, LH	1
18	42-122	Rake Spring	12
	42-177	Spring Holder	12
19	HSTP-516-18-075	Phillip Truss Head Screw, $\frac{5}{16}$ - 18 x $\frac{3}{4}$	6
	HNFL-516-18	Flange Whiz-Loc Nut $\frac{5}{16}$ - 18	6
20	42-129	Groomer Blades	3
21	42-393	Outside Brush Arm, RH	1
22	42-105	Top Strap	4
23	42-107	Matting	4
24	42-106	Bottom Strap	4
25	42-135	Finishing Blades	4
26	42-466	Brush, 21"	4
27	42-465	Brush Clamp	4
28	HB-516-18-125	Hex Bolt, $\frac{5}{16}$ - 18 x 1 $\frac{1}{4}$	12
	HNFL-516-18	Flange Whiz-Loc Nut $\frac{5}{16}$ - 18	12
29	42-453	Inside Brush Arm, RH	1
30	42-398	Brush Arm Mount, RH	1





42-3920 84"(213CM) PROBRUSH TOURNAMENT RAKE DRAWING

Fig. 1

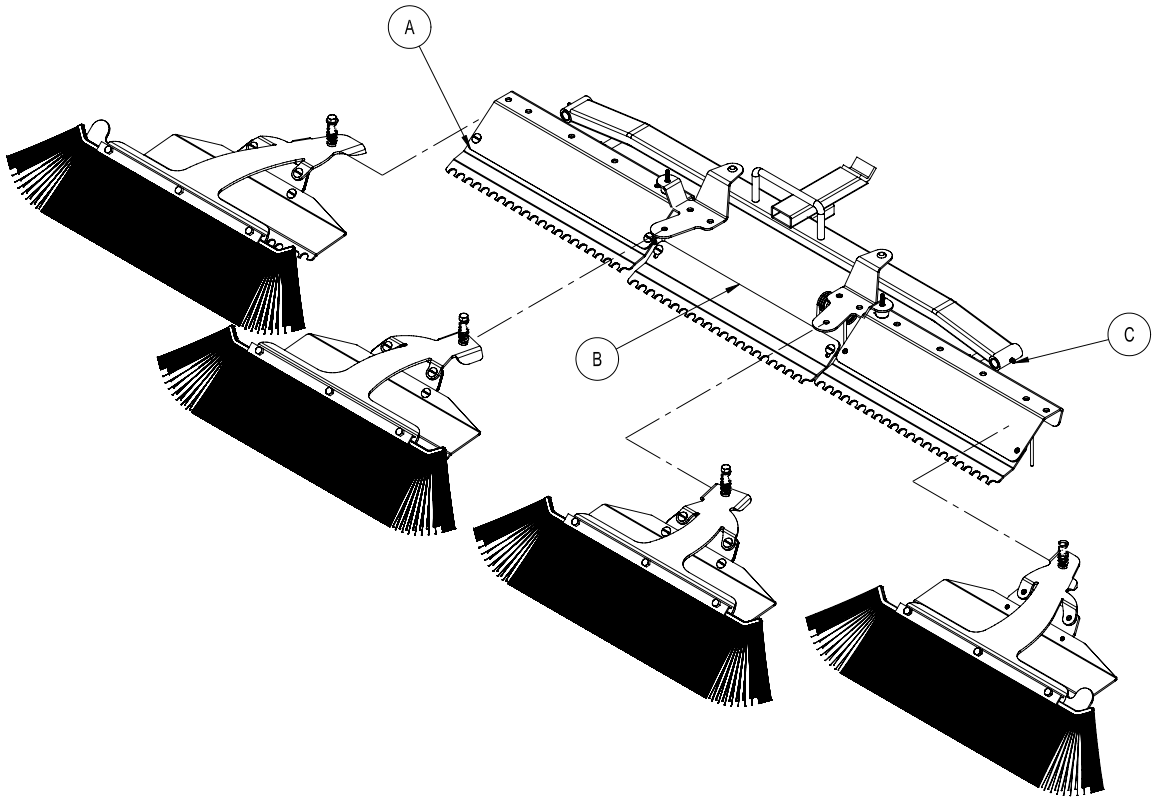

Fig. 2

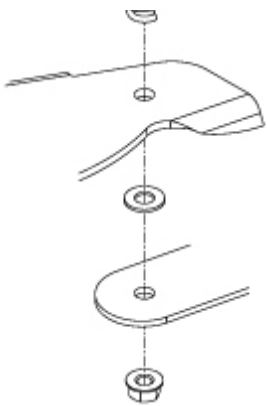

Fig. 3

Rear Attachment



## PROBRUSH TOURNAMENT RAKE ASSEMBLY INSTRUCTIONS

Your PROBRUSH TOURNAMENT RAKE comes mostly assembled.

1. Before assembly please note the two Brush/Finish Blade Assemblies (Refs A & C in Fig.1) that are mounted on the outside (RH & LH) have flat washers that are between the Brush Arms (Refs 2 & 21) and the Brush Arm Mount (Ref 6).
2. Also please note the placement of the Brush/Finish Blade Assemblies as illustrated in Fig 1. They must be mounted as illustrated to work as intended.
3. Begin assembling your PROBRUSH TOURNAMENT RAKE by inserting the Outside and Center Groomer Blade Assemblies (Refs A, B & C in Fig.1) in their locations as illustrated. Secure the Outside Assemblies with the  $\frac{1}{4}$ " Pin (Ref 11) and the Center Assembly with the  $\frac{1}{4}$ " x  $1\frac{3}{4}$ " Bolt and Lock Nut (Ref 13).
4. Mount the Brush/Finish Blade Assemblies to the Brush Arm Mounts (Refs 6, 30 & 15) as illustrated using the  $\frac{3}{8}$  x  $2\frac{1}{2}$  Bolts and Lock Nuts. Assemble with the Springs (Ref 4) as shown in Fig. 2. Please note that the  $\frac{3}{8}$ " Flat Washers are used only on the Outside Assemblies. Secure when assembled.
5. Mount your PROBRUSH TOURNAMENT RAKE to the trap rake quick hitch. Position the Rake so it is centered and equal distance away from the right and left hand tires (2-3 inches). Fig. 4. Once positioned, set the Adjustment Screws on the Hitch so they touch the trap rake hitch. Fig. 5.
6. Run machine and test for operation of the Rake by raising and lowering the assembly and with rake down turn sharp corners in both directions to ensure rake is not contacting the tires. Test Rake in sand to ensure tire tracks are covered when turning sharp corners. If the tire tracks are not covered by the Rake, turn the Adjustment Screws on the Rake Hitch so the rake comes closer to the tires when turning. For reference see Fig. 4 and 5 below.

### NOTE:

The Outside Brush/Finish Blade Assemblies may be rotated 180° for transport and for working in narrow areas, as illustrated in Fig.3 on the facing page.

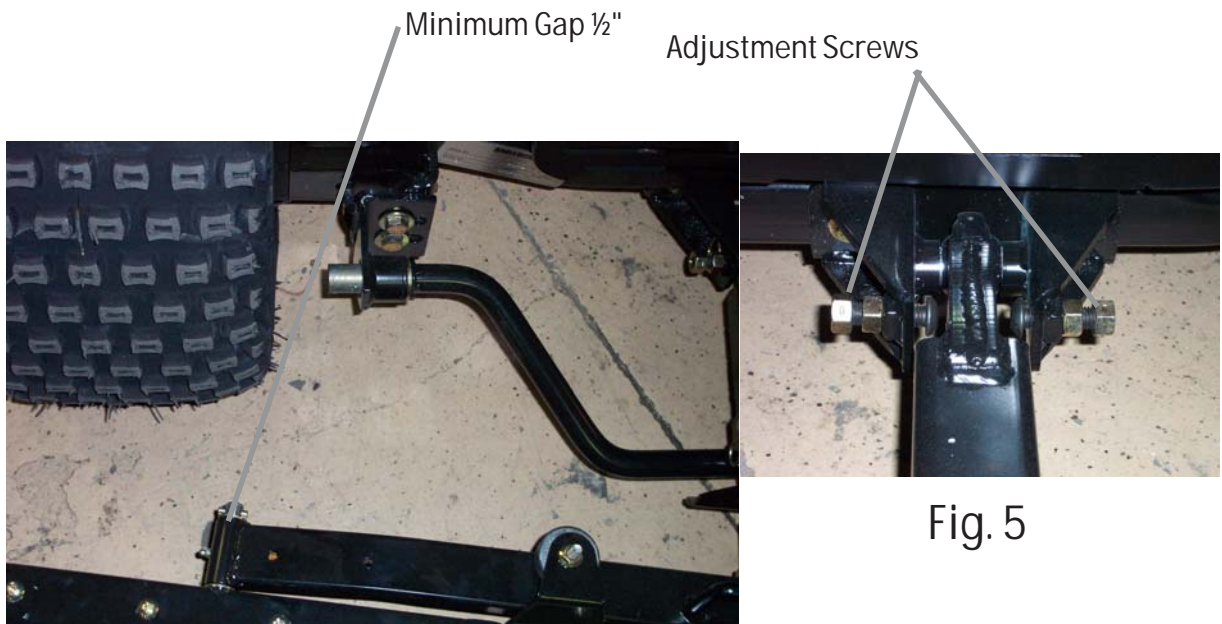

# 42-1300 84" (213CM) MILD STEEL TOURNAMENT RAKE DRAWING

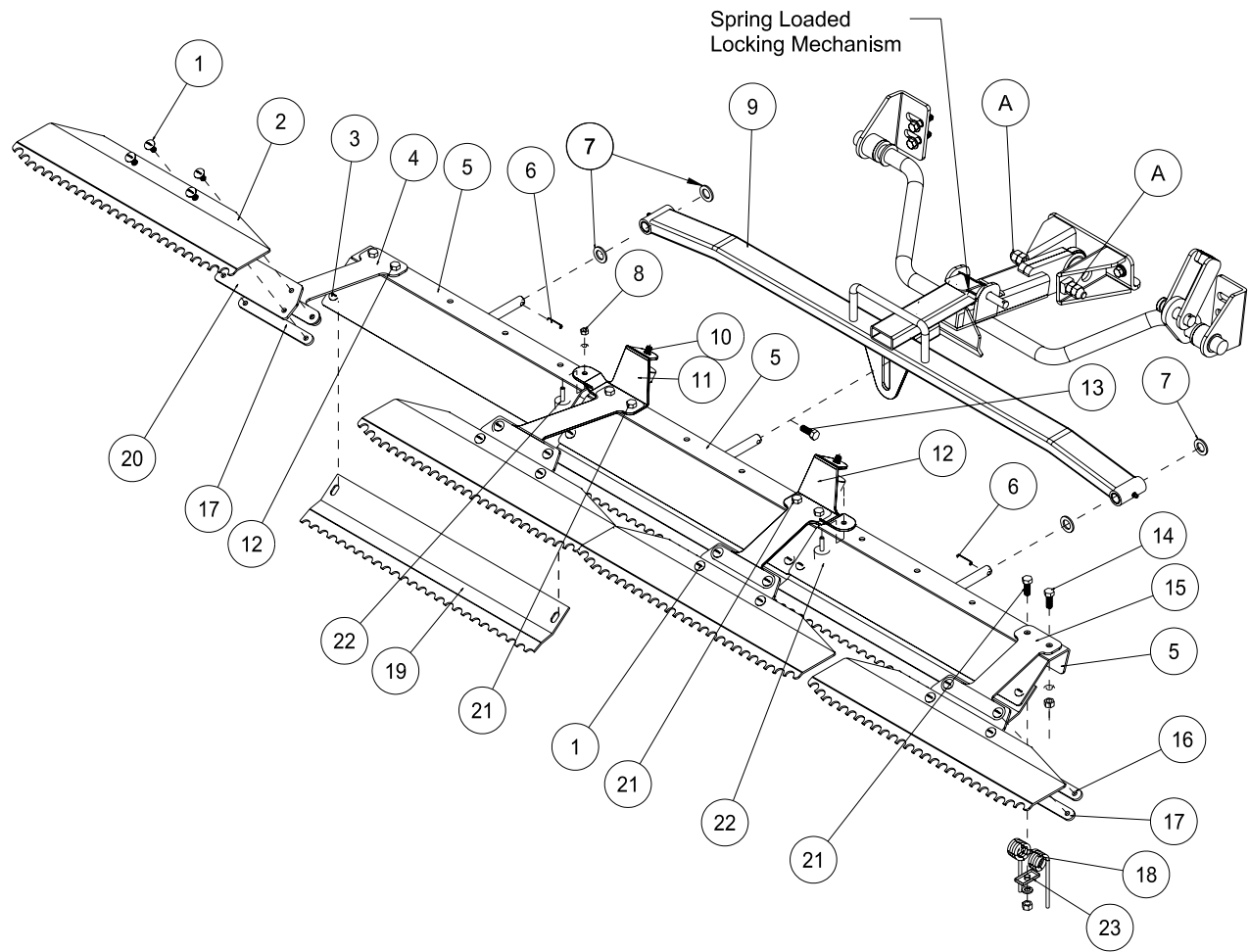

Rear Attachment





## 42-130Q 84" (213CM) MILD STEEL TOURNAMENT RAKE PARTS LIST

REF#	PART#	DESCRIPTION	QUANTITY
1	HSTP-516-18-100	Phillips Machine Screw $5/16$ - 18 x 1	16
	HNFL-516-18	Flange Loc-Nut $5/16$ - 18	16
2	42-135	Finishing Blades	4
3	HSTP-516-18-075	Phillips Machine Screw $5/16$ - 18 x $3/4$	6
	HNFL-516-18	Flange Loc-Nut $5/16$ - 18	6
4	42-111	Left Outside Mount	1
5	42-102	Outside Rake	3
6	HRP-14-100	Roll Pin $1/4$ x 1	2
7	HMB-58-14	Machine Bushing $5/8$ x 14GA	4
8	HNC-14-20	Cap Nut $1/4$ - 20	2
	HWL-14	Lock Washer $1/4$	2
9	43-144	Draw Bar	1
10	50-081	Rubber Bumper	2
11	42-110	Left Inside Mount	1
12	42-108	Inside Trowel Mount	1
13	HB-14-20-150	Bolt $1/4$ - 20 x $1\frac{1}{2}$	1
	HNTL-14-20	Lock Nut $1/4$ - 20	1
14	HSTP-516-18-125	Phillips Machine Screw $5/16$ - 18 x $1\frac{1}{4}$	12
	HNFL-516-18	Flange Loc-Nut $5/16$ - 18	12
15	42-109	Outside Towel Mount	1
16	42-105	Top Strap	4
17	42-106	Bottom Strap	4
18	42-122	Rake Spring	12
19	42-129	Groomer Blades	3
20	42-107	Matting	4
21	HSTP-38-16-125	Phillips Machine Screw $5/16$ - 18 x $1\frac{1}{4}$	4
	HNFL-516-18	Flange Loc-Nut $5/16$ - 18	4
22	15-013	Rubber Bumper	2
23	42-177	Spring Holder	12

# 42-130Q 84" (213CM) MILD STEEL TOURNAMENT RAKE DRAWING

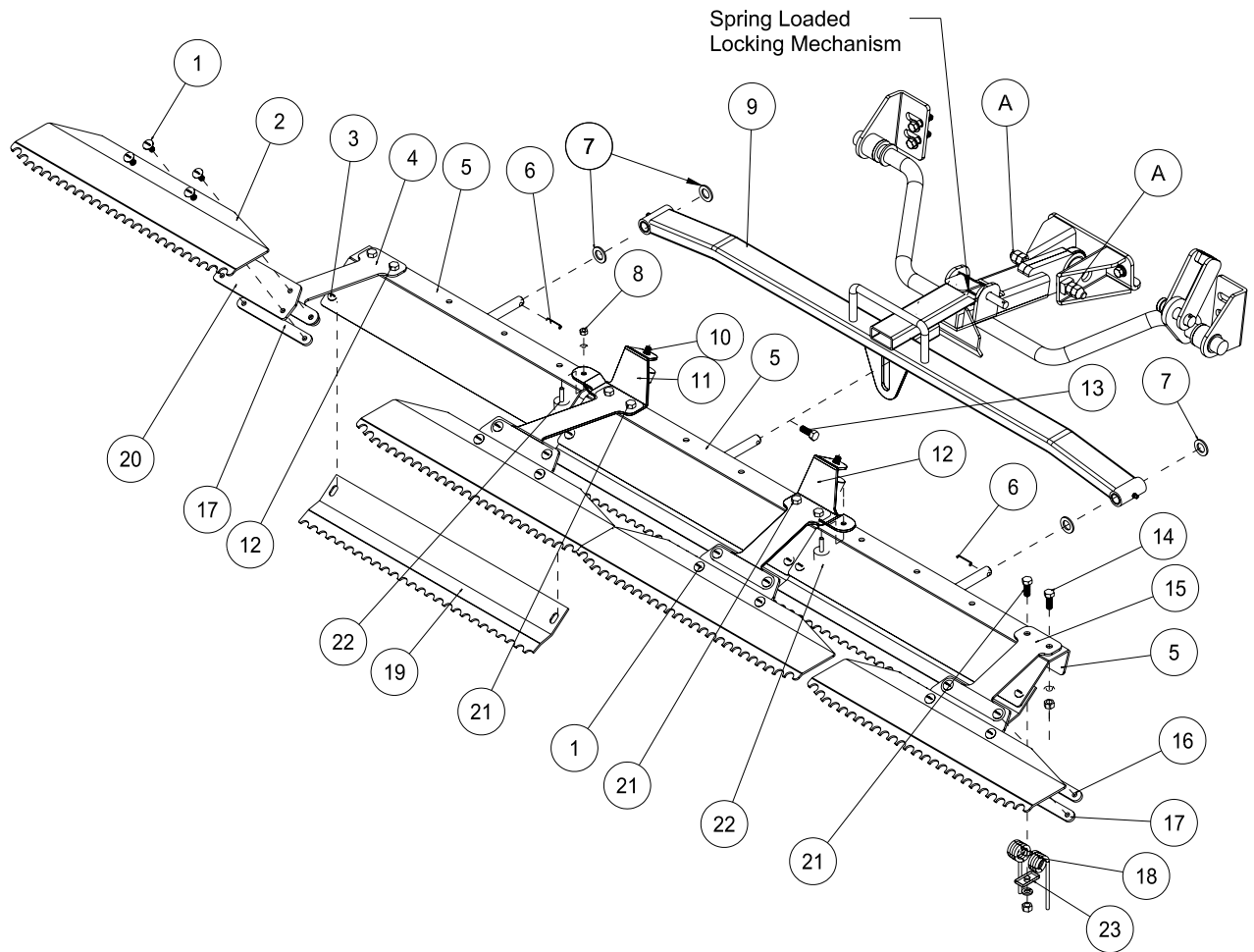

Rear Attachment



## RAKE ASSEMBLY INSTRUCTIONS

1. Bolt rake spring (Ref 18) to rake frames (Ref 5) using hardware (Ref 14). Leave the two outside holes on right, left, and center rake open.
  2. Attach rubber bumper (Ref 22) using cap nut and washer (Ref# 8). Attach rubber bumpers (Ref 10) to inside mounts (Ref 11 & 12)
  3. Attach the left outside mount (Ref 4), the left inside mount (Ref 11), the outside trowel mount (Ref 15), and the inside trowel mount (Ref 12) to the outside and center rakes (Ref 5) as shown. Use the 1<sup>1</sup>/<sub>4</sub>" truss head screws (Ref 14) on the outside hole of each rake. Use the spring holder (Ref 23) and the 1<sup>1</sup>/<sub>4</sub>" truss head screws (Ref 21) to attach rake springs (Ref 18) to the rakes under the left outside and inside mounts and the outside and inside trowel mounts.
  4. Slide a machine bushing onto outside rake frames then slide the outside rake frames (Ref 5) into the tubing on the end of the drawbar. Hold in place with another machine bushing and a roll pin (Ref 6).
  5. Attach center rake (Ref 5) to draw bar (Ref 9) as shown, using 1<sup>1</sup>/<sub>2</sub> bolts and lock nuts (Ref 13) with the shaft of the center rake in the slot on the bottom of the drawbar.
  6. Attach the matting (Ref 20) and the top strap (Ref 16) to the inside and outside mounts using the truss head screw <sup>5</sup>/<sub>16</sub> - 18 x 1 (Ref 1). Attach four finishing blades (Ref 2) to the matting on the inside and outside mounts with the truss head screw <sup>5</sup>/<sub>16</sub> - 18 x 1 (Ref 1) going through the finishing blade, matting, and bottom strap (Ref 17).
  7. Place the three groomer blades (Ref 19) under the three rake assemblies as shown, using (Ref 3).
  8. Attach the rake lift to the trap rake quick hitch, by sliding the the hitch into the spring loaded locking mechanism.
  9. With the rake on the ground pull the rake to the right side until it is 2-3 inches from the tire.
  10. Using the adjustment bolts (Ref A) on the side of hitch, adjust the bolts until it hits the trap rake hitch. Lock jam nut so adjustment will not change.
  11. Repeat steps for the left side.
  12. Turn machine on and test for operation of rake assembly by raising and lowering the rake assembly. Also with rake down, turn sharp corners to check that rake does not touch wheels.
- NOTE:** Test rake in sand to assure tire tracks are covered by the rake when turning sharp corners in either direction. If there are tire tracks, readjust using the adjusting screws on the hitch, so the rake comes closer to the tire.

# 42-132Q 72"(183CM) MILD STEEL TOURNAMENT RAKE DRAWING

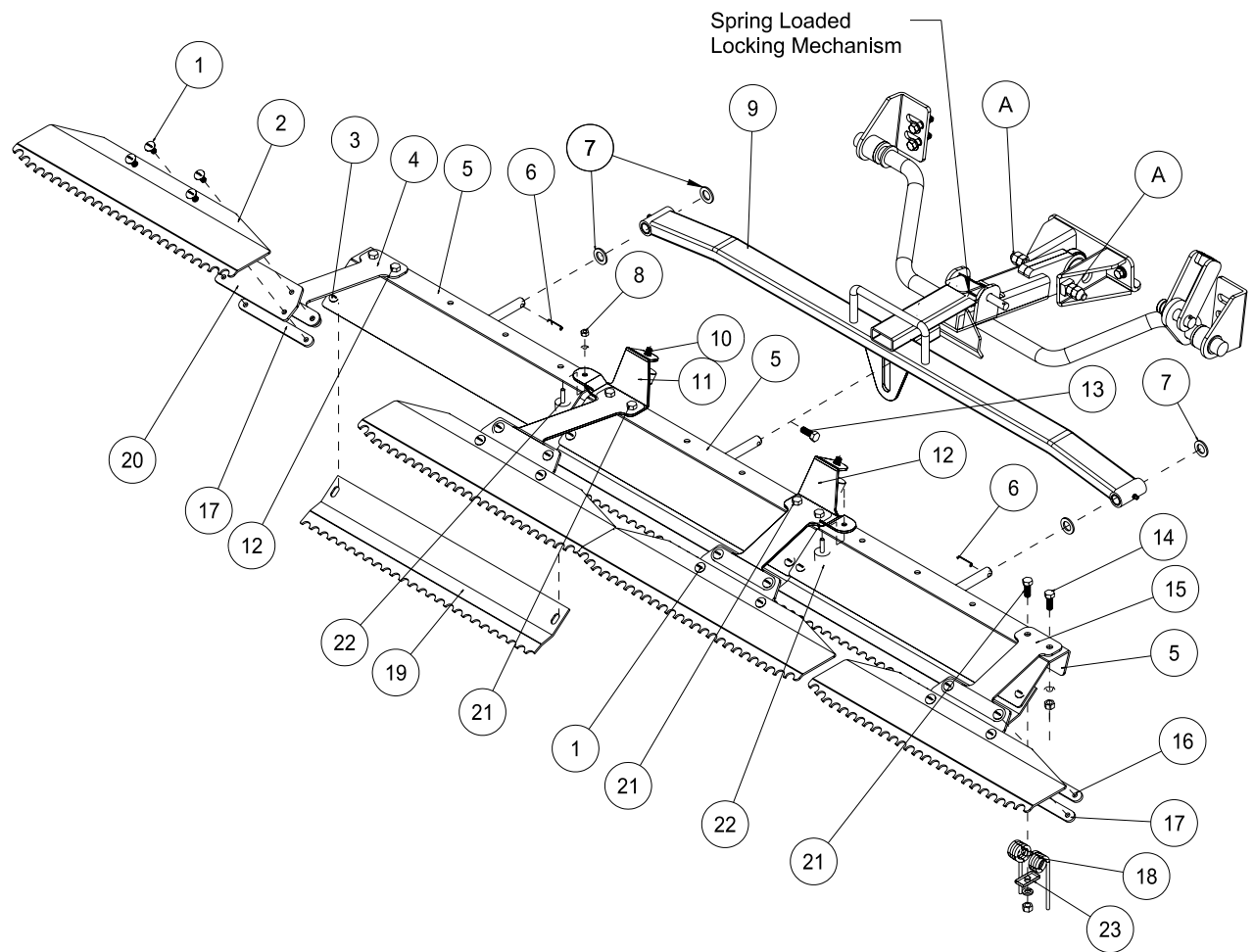

Rear Attachment

## 42-132Q 72"(183CM) MILD STEEL TOURNAMENT RAKE PARTS LIST

REF#	PART#	DESCRIPTION	QUANTITY
1	HSTP-516-18-100	Phillips Machine Screw $5/16$ - 18 x 1	16
	HNFL-516-18	Flange Loc-Nut $5/16$ - 18	16
2	42-170	Finishing Blades	4
3	HSTP-516-18-075	Phillips Machine Screw $5/16$ - 18 x $3/4$	6
	HNFL-516-18	Flange Loc-Nut $5/16$ - 18	6
4	42-111	Left Outside Mount	1
5	42-140	Outside Rake	3
6	HRP-14-100	Roll Pin $1/4$ x 1	2
7	HMB-58-14	Machine Bushing $5/8$ x 14GA	4
8	HNC-14-20	Cap Nut $1/4$ - 20	2
	HWL-14	Lock Washer $1/4$	2
9	43-154	Draw Bar	1
10	50-081	Rubber Bumper	2
11	42-110	Left Inside Mount	1
12	42-108	Inside Trowel Mount	1
13	HB-14-20-150	Bolt $1/4$ - 20 x $1\frac{1}{2}$	1
	HNTL-14-20	Lock Nut $1/4$ - 20	1
14	HSTP-516-18-125	Phillips Machine Screw $5/16$ - 18 x $1\frac{1}{4}$	12
	HNFL-516-18	Flange Loc-Nut $5/16$ - 18	12
15	42-109	Outside Towel Mount	1
16	42-105	Top Strap	4
17	42-106	Bottom Strap	4
18	42-122	Rake Spring	12
19	42-171	Groomer Blades	3
20	42-107	Matting	4
21	HSTP-38-16-125	Phillips Machine Screw $5/16$ - 18 x $1\frac{1}{4}$	4
	HNFL-516-18	Flange Loc-Nut $5/16$ - 18	4
22	15-013	Rubber Bumper	2
23	42-177	Spring Holder	12

# 42-132Q 72"(183CM) MILD STEEL TOURNAMENT RAKE DRAWING

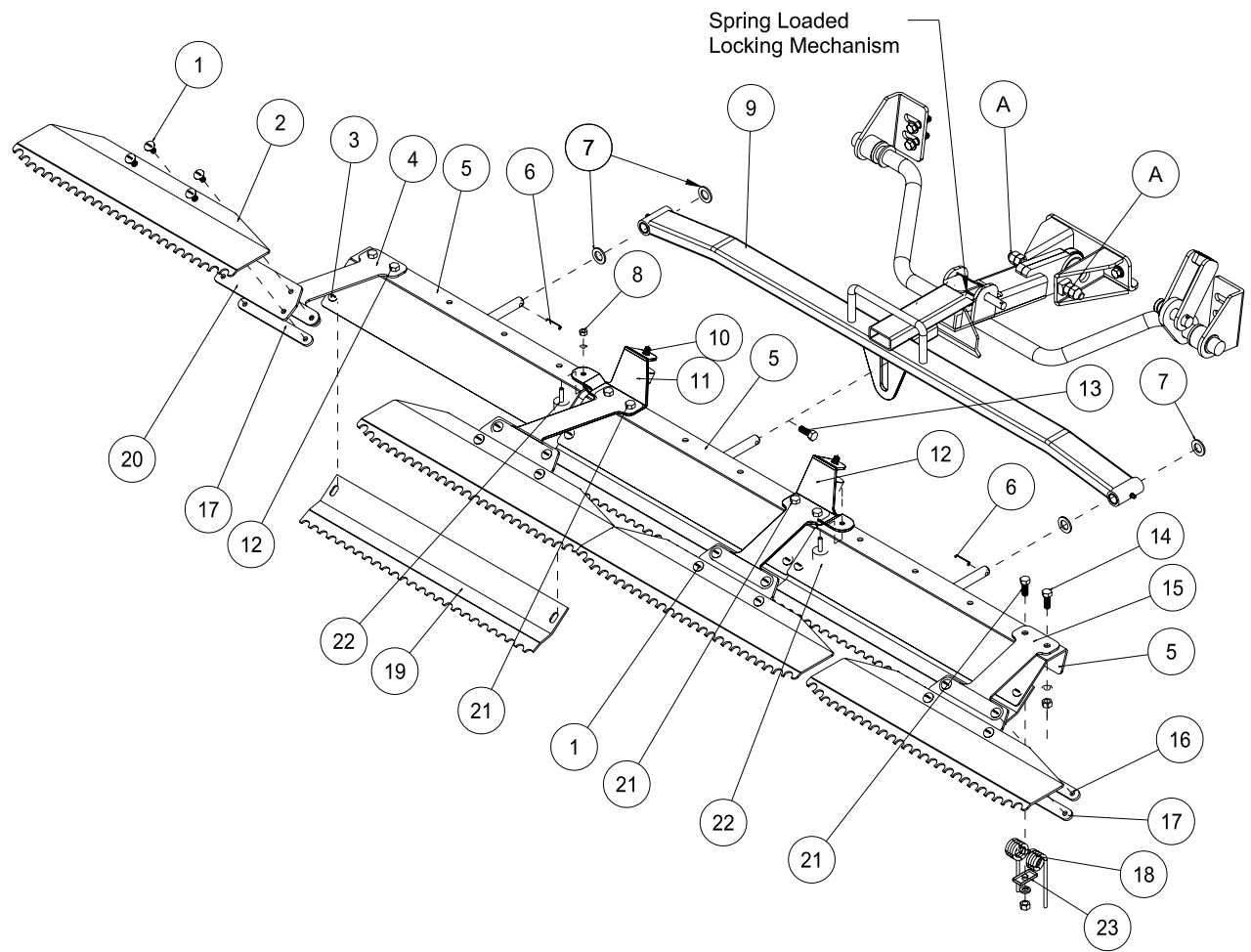

Rear Attachment

## RAKE ASSEMBLY INSTRUCTIONS

1. Bolt rake spring (Ref 18) to rake frames (Ref 5) using hardware (Ref 14). Leave the two outside holes on right, left, and center rake open.
  2. Attach rubber bumper (Ref 22) using cap nut and washer (Ref# 8). Attach rubber bumpers (Ref 10) to inside mounts (Ref 11 & 12)
  3. Attach the left outside mount (Ref 4), the left inside mount (Ref 11), the outside trowel mount (Ref 15), and the inside trowel mount (Ref 12) to the outside and center rakes (Ref 5) as shown. Use the 1<sup>1</sup>/<sub>4</sub>" truss head screws (Ref 14) on the outside hole of each rake. Use the spring holder (Ref 23) and the 1<sup>1</sup>/<sub>4</sub>" truss head screws (Ref 21) to attach rake springs (Ref 18) to the rakes under the left outside and inside mounts and the outside and inside trowel mounts.
  4. Slide a machine bushing onto outside rake frames then slide the outside rake frames (Ref 5) into the tubing on the end of the drawbar. Hold in place with another machine bushing and a roll pin (Ref 6).
  5. Attach center rake (Ref 5) to draw bar (Ref 9) as shown, using 1<sup>1</sup>/<sub>2</sub> bolts and lock nuts (Ref 13) with the shaft of the center rake in the slot on the bottom of the drawbar.
  6. Attach the matting (Ref 20) and the top strap (Ref 16) to the inside and outside mounts using the truss head screw <sup>5</sup>/<sub>16</sub> - 18 x 1 (Ref 1). Attach four finishing blades (Ref 2) to the matting on the inside and outside mounts with the truss head screw <sup>5</sup>/<sub>16</sub> - 18 x 1 (Ref 1) going through the finishing blade, matting, and bottom strap (Ref 17).
  7. Place the three groomer blades (Ref 19) under the three rake assemblies as shown, using (Ref 3).
  8. Attach the rake lift to the trap rake quick hitch, by sliding the the hitch into the spring loaded locking mechanism.
  9. With the rake on the ground pull the rake to the right side until it is 2-3 inches from the tire.
  10. Using the adjustment bolts (Ref A) on the side of hitch, adjust the bolts until it hits the trap rake hitch. Lock jam nut so adjustment will not change.
  11. Repeat steps for the left side.
  12. Turn machine on and test for operation of rake assembly by raising and lowering the rake assembly. Also with rake down, turn sharp corners to check that rake does not touch wheels.
- NOTE:** Test rake in sand to assure tire tracks are covered by the rake when turning sharp corners in either direction. If there are tire tracks, readjust using the adjusting screws on the hitch, so the rake comes closer to the tire.

# 13-4380 RAKE ASSEMBLY WITH FINISHING BLADES DRAWING

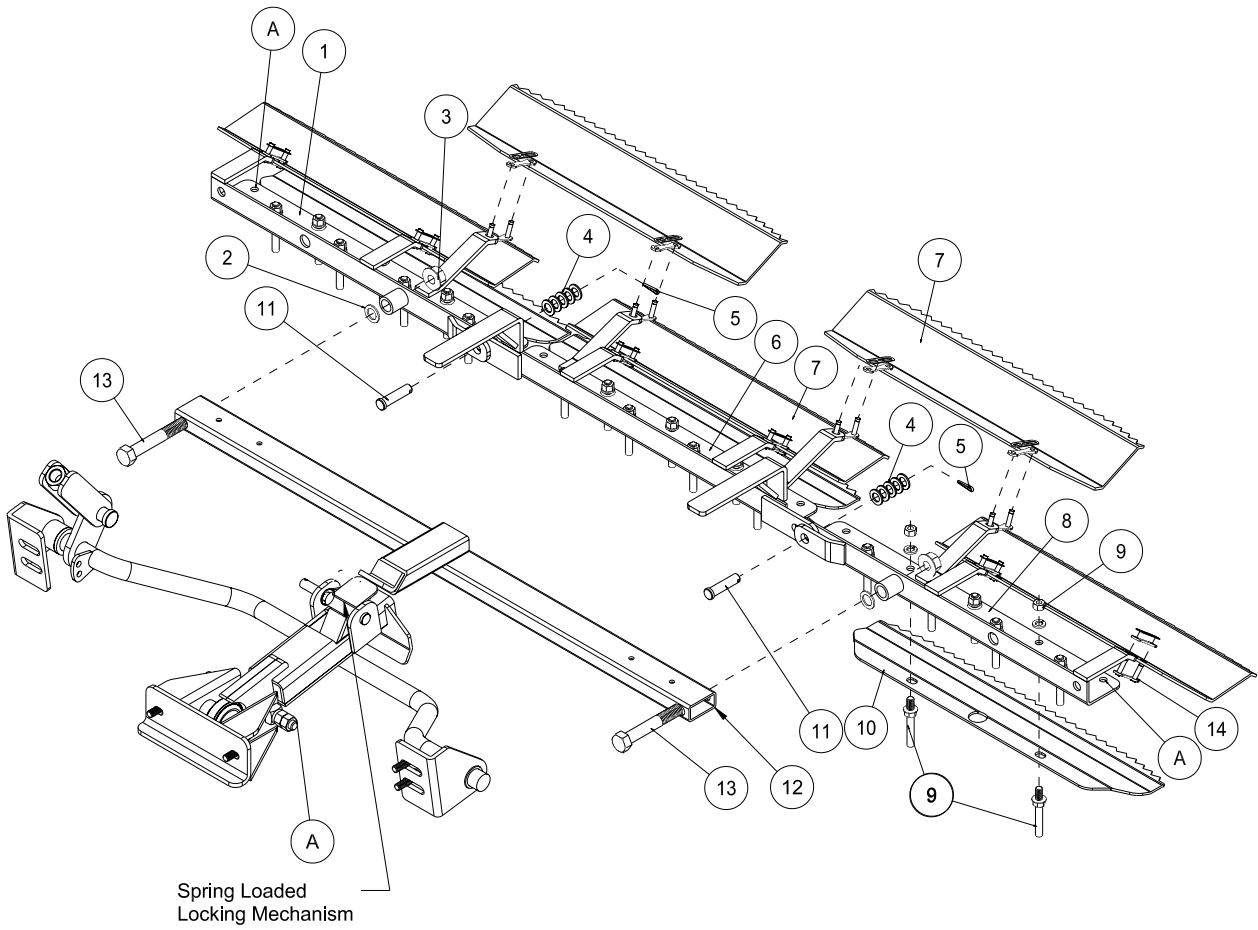

Rear Attachment



## 13-438Q RAKE ASSEMBLY WITH FINISHING BLADES PARTS LIST

REF#	PART#	DESCRIPTION	QUANTITY
1	13-441	Right Rake	1
2	HMB-58-14	Machine Bushing $\frac{5}{8}$ x 14GA	2
3	HNCL-58-11	Lock Nut $\frac{5}{8}$ - 11	2
4	HMB-12-14	Machine Bushing $\frac{1}{2}$ x 14GA	10
5	HP-18-100	Cotter Pin $\frac{1}{8}$ x 1	2
6	13-440	Center Rake	1
7	13-443	Finishing Blade	5
8	13-439	Left Rake	1
9*		Rake teeth	25
10	13-442	Groomer Blade	3
11	HCP-12-150	Clevis Pin $\frac{1}{2}$ - $1\frac{1}{2}$	2
12	43-145	Drawbar	1
13	HB-58-11-400	Bolt $\frac{5}{8}$ - 11 x 4	2
14	13-417	Connector Link	10
*	13-090	Rake Teeth Kit (Studs and Hardware)	1

## INSTALLATION INSTRUCTIONS

1. Bolt rake teeth (Ref 9) to frames, keeping all the same length. Leave the two outside holes on right and left rake open (Ref A).
2. Lay out rake frames (Ref 1,6 and 8). Connect them using clevis pin, machine bushing and cotter pin (Ref 11, 4 and 5).
3. Attach drawbar to left and right frames using bolt, machine bushing, and nut (Ref 13, 2 and 3).
4. Attach five finishing blades (Ref 7) to the tabs of the rake frames using master link (Ref 14). Blades may be mounted with saw tooth up or down, depending on the desired finish of the sand trap.
5. Attach the rake lift to the trap rake quick hitch, by sliding the the hitch into the spring loaded locking mechanism.
6. With the rake on the ground pull the rake to the right side until it is 2-3 inches from the tire.
7. Repeat steps on left side.
8. Turn machine on and test for operation of rake assembly by raising and lowering the rake assembly. Also with rake down, turn sharp corners to check that rake does not touch wheels.
9. **NOTE:** Test rake in sand to assure tire tracks are covered by the rake when turning sharp corners in either direction. If there are tire tracks, readjust using the adjusting screws on the hitch, so the rake comes closer to the tire.

### GROOMER BLADES - GOLF COURSE USE ONLY.

1. Place the three groomer blades (Ref 10) under the three rake assemblies (Ref 1, 6 and 8) .
2. Center blades below rear most row of rake teeth. The blade is designed to miss the outside two "teeth" and fit around the center 'tooth'.
3. Remove the two 'teeth' that line up with slots of each groomer blade. Move blade up and into position and reattach 'teeth'. Blade thickness should be accounted for by shortening the 'teeth' an equal length.

# 13-2980 FAN RAKE ATTACHMENT DRAWING

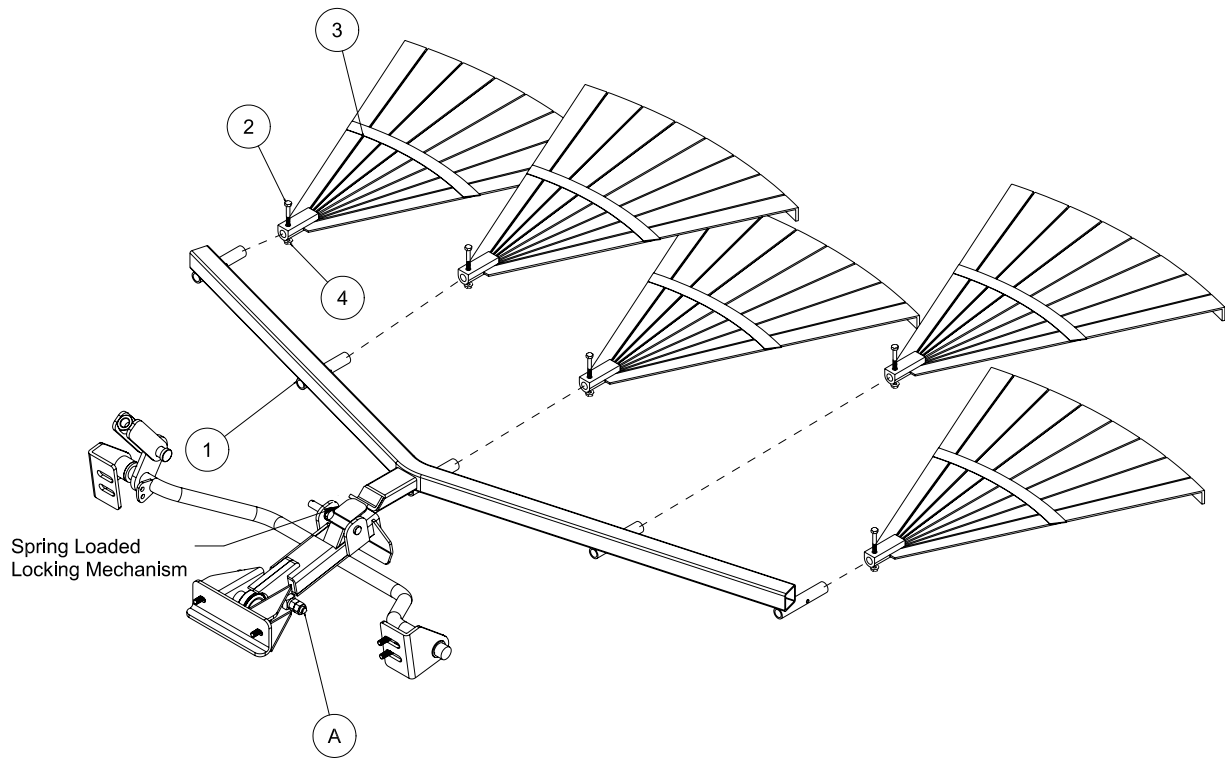

Rear Attachment

## 13-2980 FAN RAKE ATTACHMENT PARTS LIST

REF#	PART#	DESCRIPTION	QUANTITY
1	43-153	Frame	1
2	HB-14-20-200	Bolt $\frac{1}{4}$ - 20 x 2	5
3	13-310	Rake	5
4	HNCL-14-20	Center Lock Nut $\frac{1}{4}$ - 20	5

## INSTALLATION INSTRUCTIONS

1. Assemble the five rakes (Ref 3) to the frame using the bolt and center lock nuts (Ref 2 and 4). Slide the fan rake assembly under the rear of the trap rake to the hitch.
2. Attach the rake lift to the trap rake quick hitch, by sliding the the hitch into the spring loaded locking mechanism.
3. With the rake on the ground pull the rake to the right side until it is 2-3 inches from the tire.
4. Repeat steps on left side.
5. Turn machine on and test for operation of rake assembly by raising and lowering the rake assembly. Also with rake down, turn sharp corners to check that rake does not touch wheels.

26-0070 PROFESSIONAL INFIELD FINISHER DRAWING

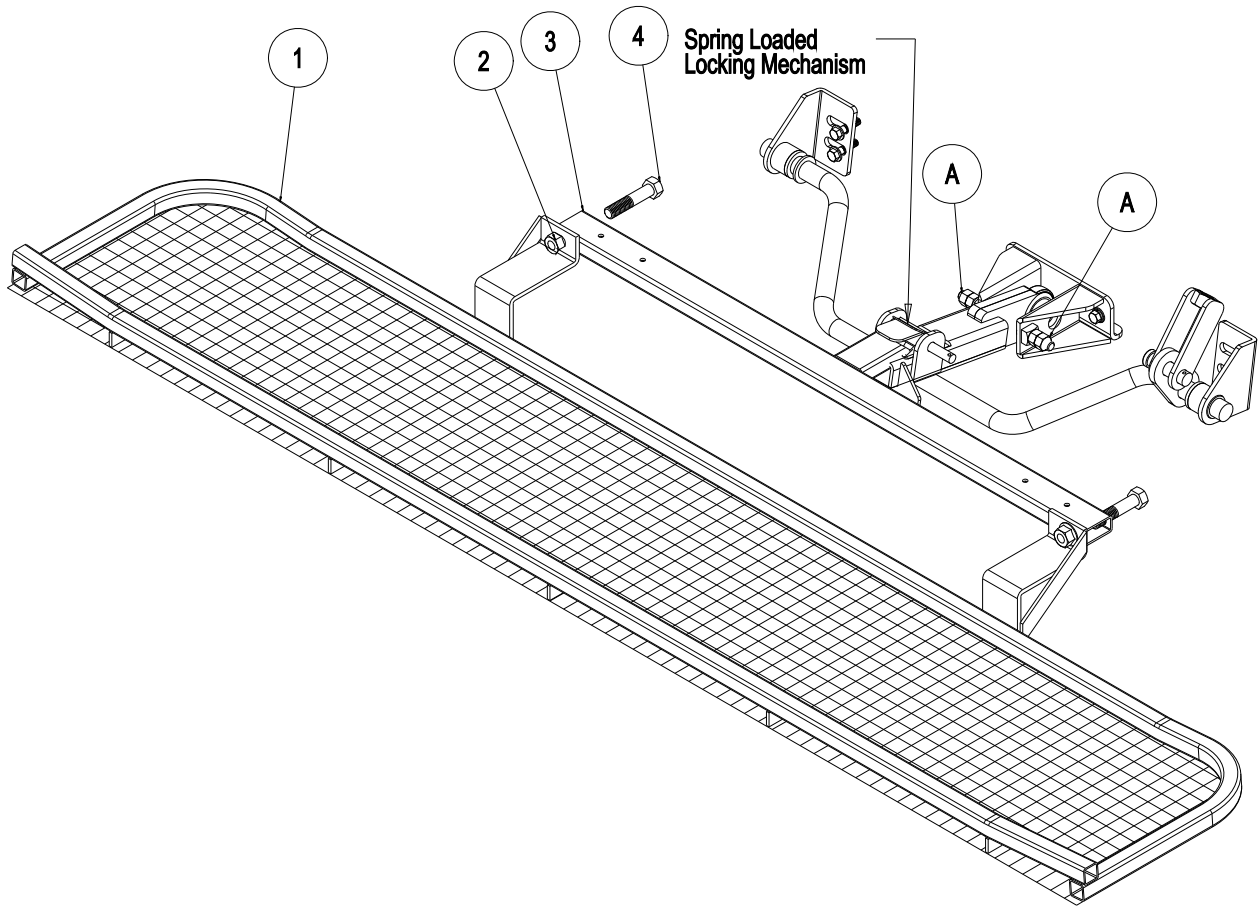

Rear Attachment

## 26-0070 PROFESSIONAL INFIELD FINISHER PARTS LIST

REF#	PART#	DESCRIPTION	QUANTITY
1	26-045	Leveling Screen	1
2	HNCL-58-11	Center Lock Nut $\frac{5}{8}$ - 11	2
3	43-152	Drawbar	1
4	HB-58-11-300	Bolt $\frac{5}{8}$ - 11 x 3	2

## INSTALLATION INSTRUCTIONS

The Professional Field Finisher is used for smoothing and leveling fields to professional standards.

1. Attach leveling screen (Ref 1) to drawbar (Ref 3) using two bolts (Ref 4) and center lock nuts (Ref 2).
2. Mount Professional Field Finisher to the hitch on the trap rake by sliding the drawbar into the quick hitch locking mechanism.
3. When Professional Field Finisher is attached, adjust bolts on hitch (Ref A) to hold Finisher in desired position.
4. **NOTE:** When assembled properly, rake will angle down from front to back. If front of finisher is not higher than the back, damage will result to infield.
5. When removing the attachment from machine. Push down on quick hitch locking mechanism and pull accessory out.

# 43-0020 FLEX ACTION FIELD FINISHER WITH BRUSH DRAWING

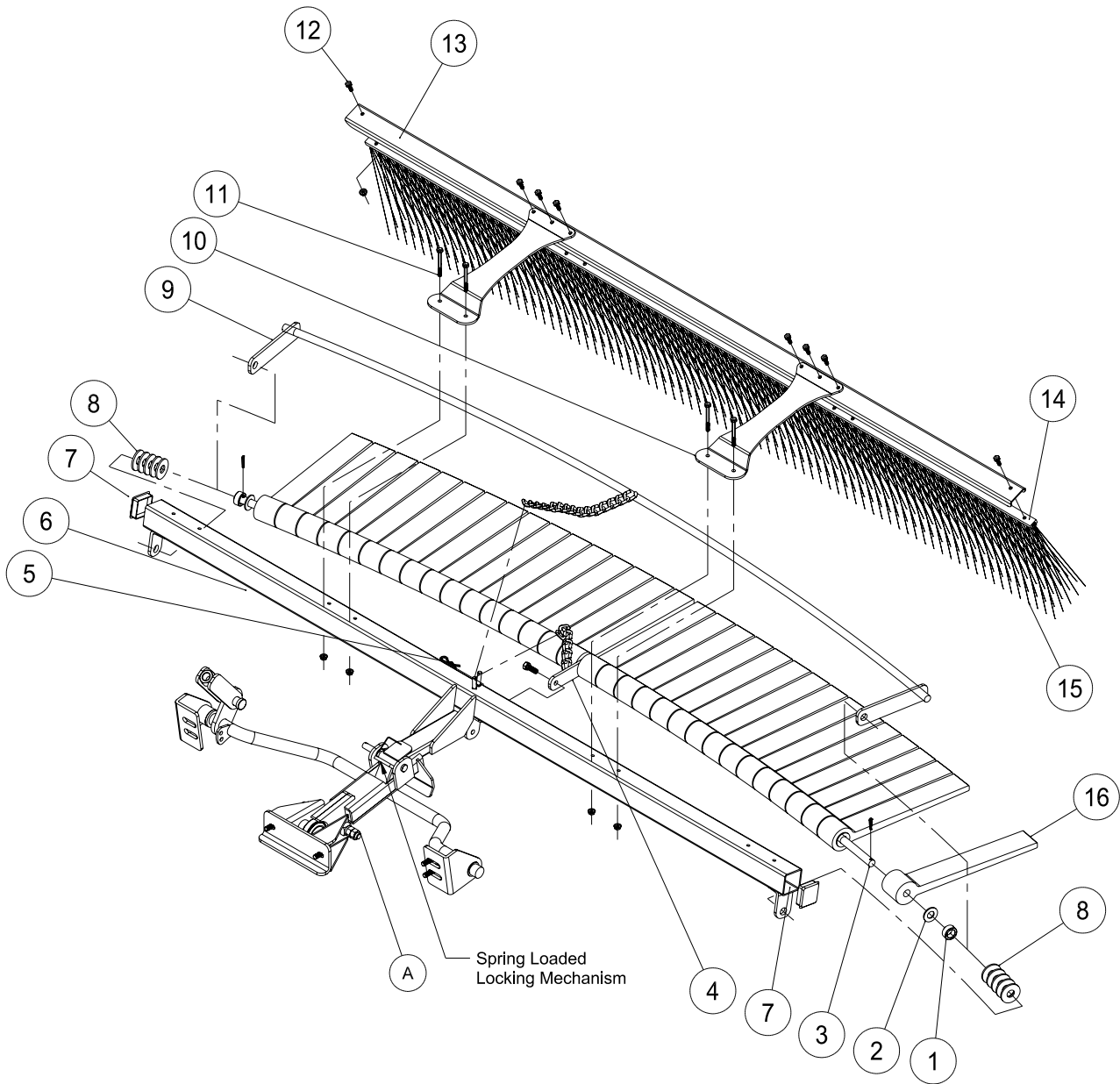

Rear Attachment

## 43-0020 FLEX ACTION FIELD FINISHER WITH BRUSH PARTS LIST

REF#	PART#	DESCRIPTION	QUANTITY
1	11-040	Spacer, 3/4"	2
2	HW-58	Washer, 5/8	32
3	26-049	Mounting Bar	1
	HP-18-100	Cotter Pin, 1/8 x 1	2
4	26-048	Flail Bar Strap	1
	HB-38-16-100	Bolt 3/8-16 x 1	1
	HNCL-38-16	Center Lock Nut 3/8-16	1
5	HHP-18	Bridge Pin, 1/8	2
6	43-146	Frame	1
7	18-297	Cap Plug	2
8	HMB-58-14	Machine Bushing 5/8 x 14GA	10
9	26-047	Leveler Bar	1
10	43-041	Mount Bracket	2
11	HB-14-20-250	Bolt, 1/4-20 x 2 1/2	4
	HNFL-14-20	Flange Whiz-Lock Nut, 1/4-20	4
12	HB-14-20-075	Bolt, 1/4-20 x 3/4	8
	HNFL-14-20	Flange Whiz-Lock Nut, 1/4-20	8
13	13-688	Brush Channel	1
14	13-683	Brush Track	1
15	13-682	Brush, 77 x 11	1
16	26-041	Rasp Flail	32

# 43-002 Q FLEX ACTION FIELD FINISHER WITH BRUSH DRAWING

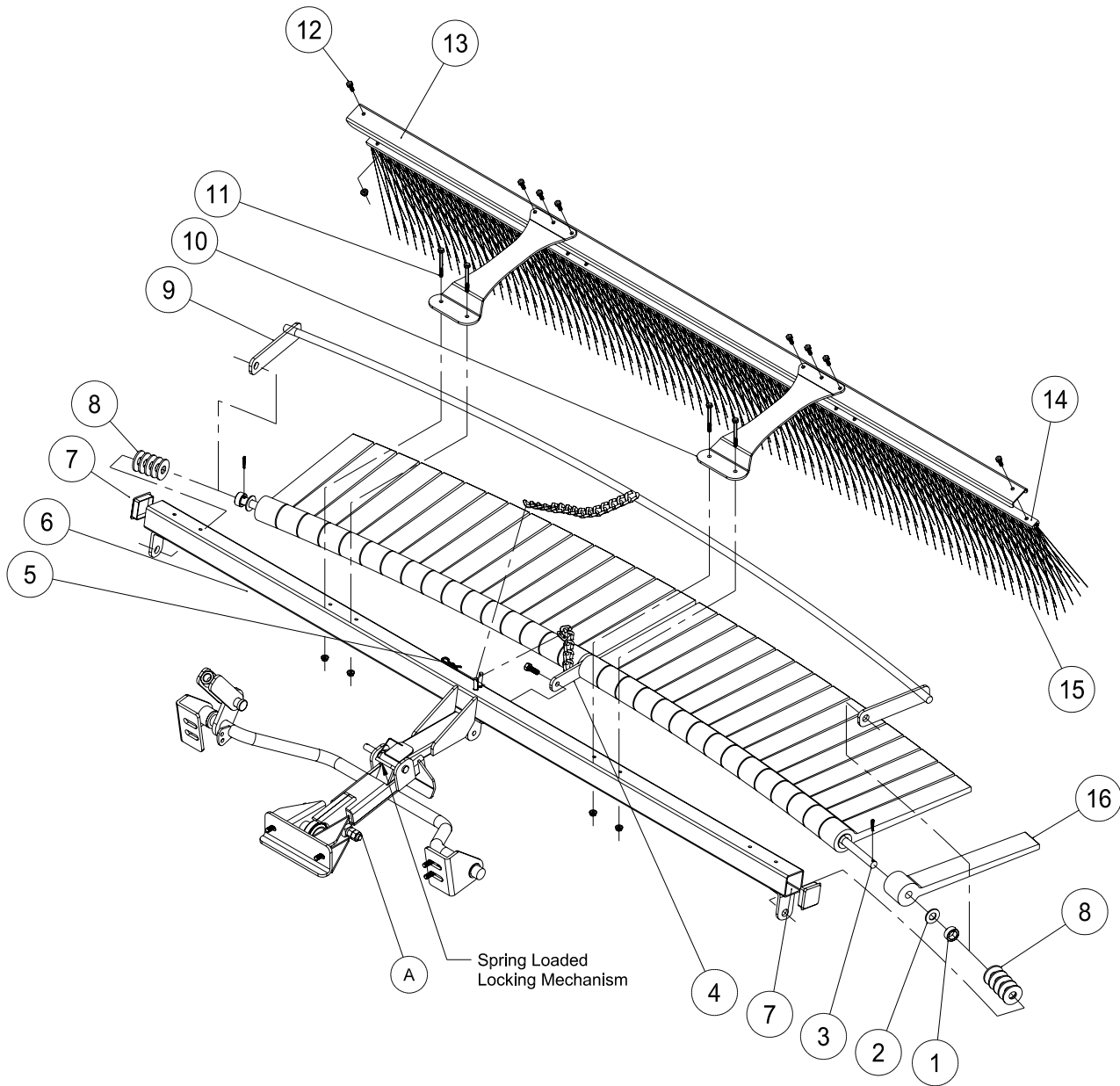

Rear Attachment



## 43-0020 FLEX ACTION FIELD FINISHER WITH BRUSH INSTRUCTIONS

### ASSEMBLY INSTRUCTIONS

1. Install flail bar strap (Ref 4) to center of mounting bar (Ref 3) with chain on top of flail bar strap and mounting bar bent away from you. Apply a light coat of lubricant to overall length of mounting bar.
2. Install one rasp flail (Ref 16) with knobby side down adjacent to sides of flail bar strap. Now install a flat washer (Ref 2) so it sits adjacent with the outside of the rasp flail. Continue to install flails with knobby sides down with washers between until you have 16 flails and washers on each side of bar strap. Force all flails tightly toward bar strap.
3. After all 32 flails have been installed, place one spacer (Ref 1) to each end of mounting bar adjacent to washer.
4. Install leveler bar (Ref 9) to mounting bar, with curved leveler bar resting on top on the smooth sides of flails. If all flails and washers do not fit snugly at this time, remove leveler bar and install enough machine bushings to ensure a snug fit. Then reinstall leveler bar.
5. Lay the frame (Ref 6) on the floor or bench with welded tabs facing up. Install ends of assembled mounting bar, with knobby sides of flails up, into welded tabs on each end of frame and secure with  $\frac{1}{8}$  x 1 cotter pin.
6. Install flail bar strap (Ref 4) to center tab on frame with  $\frac{3}{8}$  -16 x 1 bolt and  $\frac{3}{8}$  -16 center lock nut. Loose fit is required. Do not over tighten.
7. Flip assembly over so knobby sides of flails are now facing down. Install hitch to frame with clevis pin (Ref 3) and cotter pin (Ref 24). The hitch should be attached to the frame as shown.
8. Install bar strap chain over welded pin on frame. Install leveler bar chain on to pin and secure in place with bridge pin. Use last bridge pin and clevis pin to hitch field finisher to your machine.

### OPERATING INSTRUCTIONS

Running attachment with all flails down, flat on the surface, will provide a leveling function. Running attachment partially raised and flails at a 20° - 40° angle in relation to the level surface, will provide a finishing function. The flails increase down pressure for desired finish. Drive in wide circular patterns and increase or decrease ground speed to achieve desired finish.

### BRUSH ASSEMBLY

1. Place the brush (Ref 15) into the brush track (Ref 14). Place the brush channel (Ref 13) between the brush track and the mounting brackets. Now bolt the mounting brackets (Ref 10) to the brush track using the  $\frac{1}{4}$ -20 x  $\frac{3}{4}$  bolts and  $\frac{1}{4}$ -20 flange whiz-lock nuts (Ref 12).
2. Mount the brush assembly to the frame using the (4)  $\frac{1}{4}$ -20 x 2 $\frac{1}{2}$  bolts and  $\frac{1}{4}$ -20 flange whiz-lock nuts (Ref 11).

# 26-008Q FLEX ACTION FIELD FINISHER DRAWING

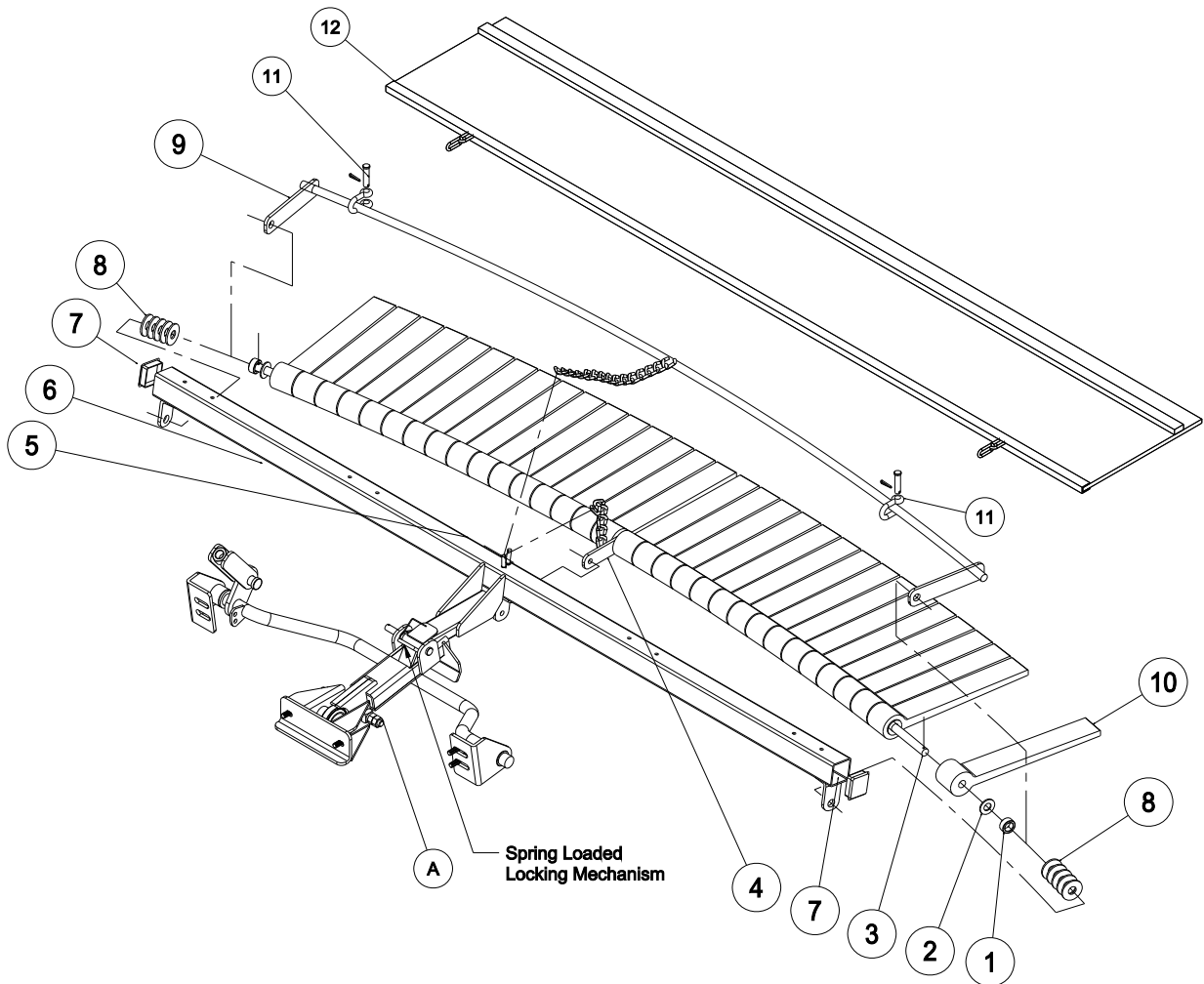

Rear Attachment

## 26-0080 FLEX ACTION FIELD FINISHER PARTS LIST

REF#	PART#	DESCRIPTION	QUANTITY
1	11-040	Spacer $\frac{3}{4}$ "	2
2	HW-58	Washer $\frac{5}{8}$	32
3	26-049	Mounting Bar	1
4	26-048	Flail Bar Strap	1
	HB-38-16-100	Bolt $\frac{3}{8}$ - 16 x 1	1
	HNCL-38-16	Center Lock Nut $\frac{3}{8}$ - 16	1
5	HHP-18	Bridge Pin $\frac{1}{8}$	2
6	43-146	Frame	1
7	18-297	Cap Plug	2
8	HMB-58-14	Machine Bushing $\frac{5}{8}$ x 14GA	10
9	26-047	Leveler Bar	1
10	26-041	Rasp Flail	32
11	21-260	Clevis	2
12	26-115	Mesh Finisher	1

## INSTALLATION INSTRUCTIONS

1. Install flail bar strap (Ref 4) to center of mounting bar (Ref 3) with chain on top of flail bar strap and mounting bar bent away from you. Apply a light coat of lubricant to overall length of mounting bar.
2. Install one rasp flail (Ref 16) with knobby side down adjacent to sides of flail bar strap. Now install a flat washer (Ref 2) so it sits adjacent with the outside of the rasp flail. Continue to install flails with knobby sides down with washers between until you have 16 flails and washers on each side of bar strap. Force all flails tightly toward bar strap.
3. After all 32 flails have been installed, place one spacer (Ref 1) to each end of mounting bar adjacent to washer.
4. Install leveler bar (Ref 9) to mounting bar, with curved leveler bar resting on top on the smooth sides of flails. If all flails and washers do not fit snugly at this time, remove leveler bar and install enough machine bushings to ensure a snug fit. Then reinstall leveler bar.
5. Lay the frame (Ref 6) on the floor or bench with welded tabs facing up. Install ends of assembled mounting bar, with knobby sides of flails up, into welded tabs on each end of frame and secure with  $\frac{1}{8}$  x 1 cotter pin.
6. Install flail bar strap (Ref 4) to center tab on frame with  $\frac{3}{8}$  -16 x 1 bolt and  $\frac{3}{8}$  -16 center lock nut. Loose fit is required. Do not over tighten.
7. Flip assembly over so knobby sides of flails are now facing down. Install hitch to frame with clevis pin (Ref 3) and cotter pin (Ref 24). The hitch should be attached to the frame as shown.
8. Install bar strap chain over welded pin on frame. Install leveler bar chain on to pin and secure in place with bridge pin. Use last bridge pin and clevis pin to hitch field finisher to your machine.

### OPERATING INSTRUCTIONS

Running attachment with all flails down, flat on the surface, will provide a leveling function. Running attachment partially raised and flails at a 20° - 40° angle in relation to the level surface, will provide a finishing function. The flails increase down pressure for desired finish. Drive in wide circular patterns and increase or decrease ground speed to achieve desired finish.

# 42-586Q GREEN STAR RBS MAIN FRAME DRAWING

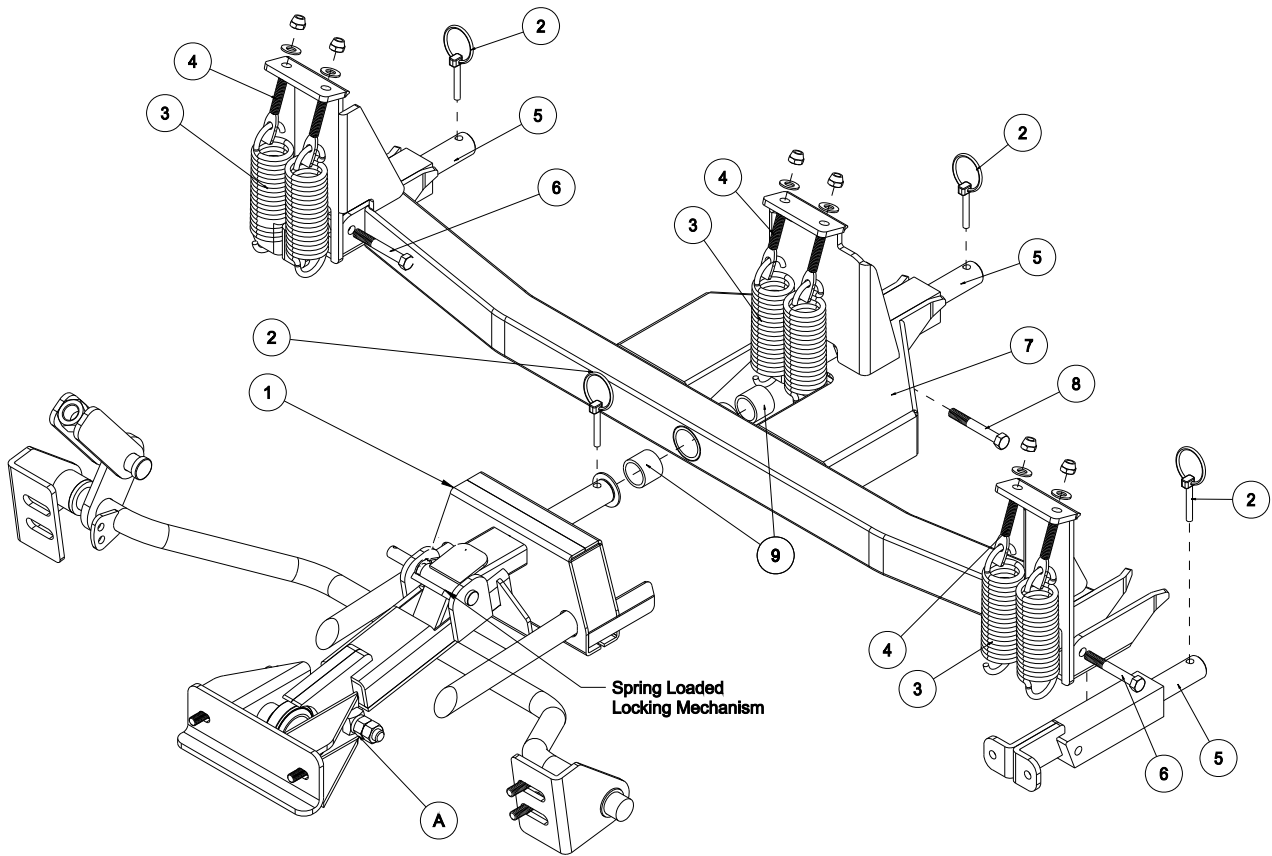

Rear Attachment

## 42-586Q GREEN STAR RBS MAIN FRAME PARTS LIST

REF#	PART#	DESCRIPTION	QUANTITY
1	43-155	Hitch	1
2	42-539	Lynch Pin <sup>5</sup> / <sub>16</sub>	4
3	42-536	Spring	6
4	42-537	Spade Bolt	6
	HNHL-38-16	Lock Nut <sup>3</sup> / <sub>8</sub> - 16	6
5	42-576	Spring Tower	3
6	HB-38-16-275	Bolt <sup>3</sup> / <sub>8</sub> - 16 x 2 <sup>3</sup> / <sub>4</sub>	2
	HNHL-38-16	Lock Nut <sup>3</sup> / <sub>8</sub> - 16	2
7	42-577	Frame	1
8	HB-38-16-250	Bolt <sup>3</sup> / <sub>8</sub> - 16 x 2 <sup>1</sup> / <sub>2</sub>	1
	HNCL-38-16	Center Lock Nut <sup>3</sup> / <sub>8</sub> - 16	1
9	18-295	Oilite Bushing (part of 42-577)	2

42-581 GREEN STAR RBS ROLLER SET (3) DRAWING

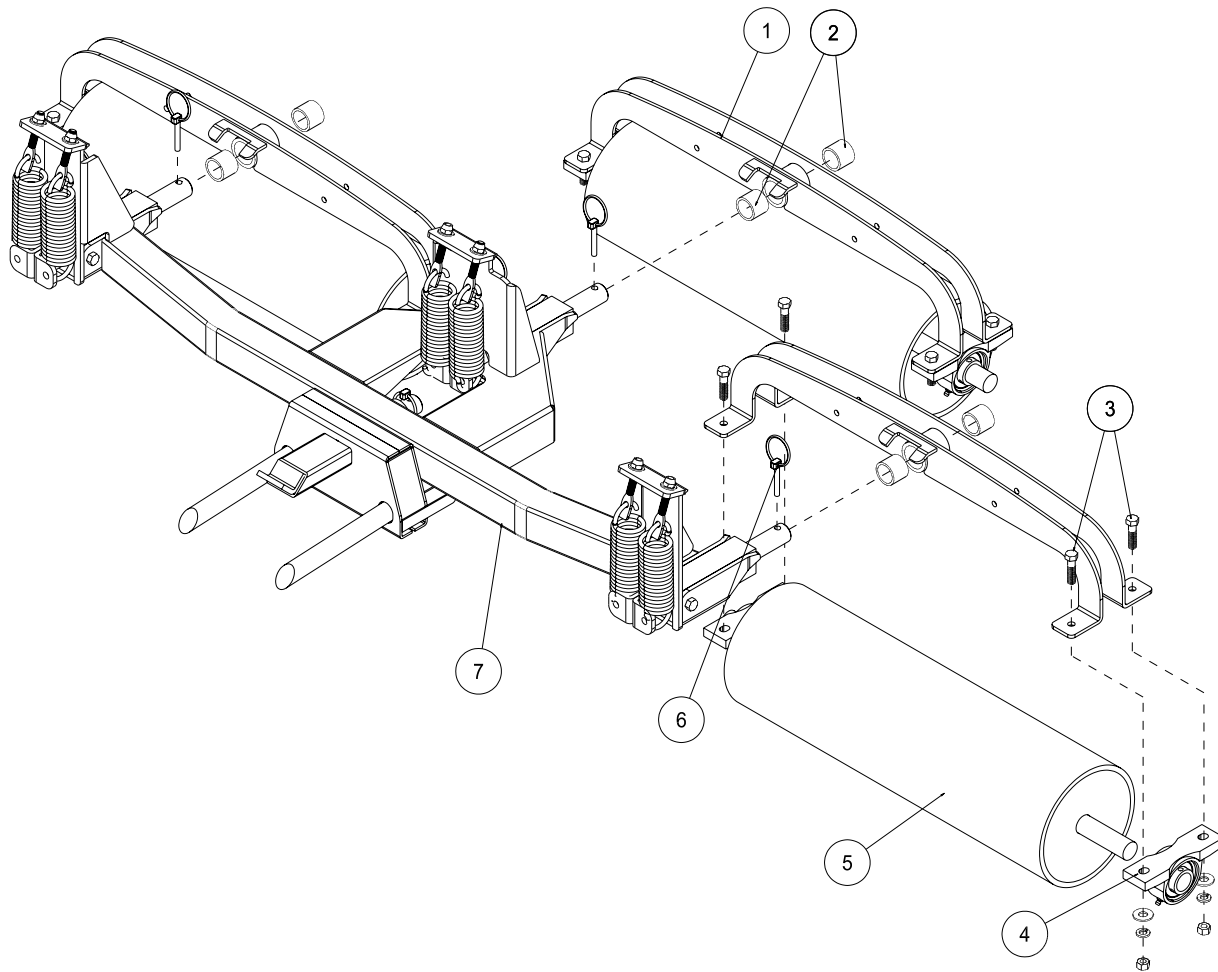

Rear Attachment

## 42-581 GREEN STAR RBS ROLLER SET (3) PARTS LIST

REF#	PART#	DESCRIPTION	QUANTITY
1	42-574	Fork	3
2	18-295	Oilite Bushing (part of 42-574)	6
3	HB-38-16-150	Bolt $\frac{3}{8}$ - 16 x 1 $\frac{1}{2}$	12
	HWL-38	Lock Washer $\frac{3}{8}$	12
	HW-38	Washer $\frac{3}{8}$	12
	HN-38-16	Nut $\frac{3}{8}$ - 16	12
4	11-094	Pillow Block	6
5	42-584	Roller	3
6	42-539	Lynch Pin $\frac{5}{16}$ (part of main frame)	3
7	42-586Q	Green Star RBS Main Frame	1

## ADJUSTMENTS AND OPERATION INSTRUCTIONS

### ADJUSTMENT

The springs are preset for maximum down pressure, and should not need to be adjusted. If you feel the need to adjust the springs please call for further instructions. The unit comes pre-adjusted for most models. The four adjustment holes on the hitch are for making sure all three rollers are touching the ground at the same pressure. When installing roller system start with the lower mounting holes on hitch.

Tire pressure should be 4 psi in the front and 7 psi in the rear tire for best traction.

### OPERATION

Make sure the rolling system has been installed and adjusted properly for your model of bunker rake. Always transport in fully raised position. Always remove flag pole before rolling green. Do not stop on green while rolling. Do not roll up steep slopes or loss of traction may result. Do not turn while rolling.

To begin rolling, lower unit all the way down as you come across collar and continue straight across green until reaching other collar and raise as you come off of green. Overlap stripes the same as if you were mowing.

42-585 GREEN STAR RBS BRUSH SET (3) DRAWING

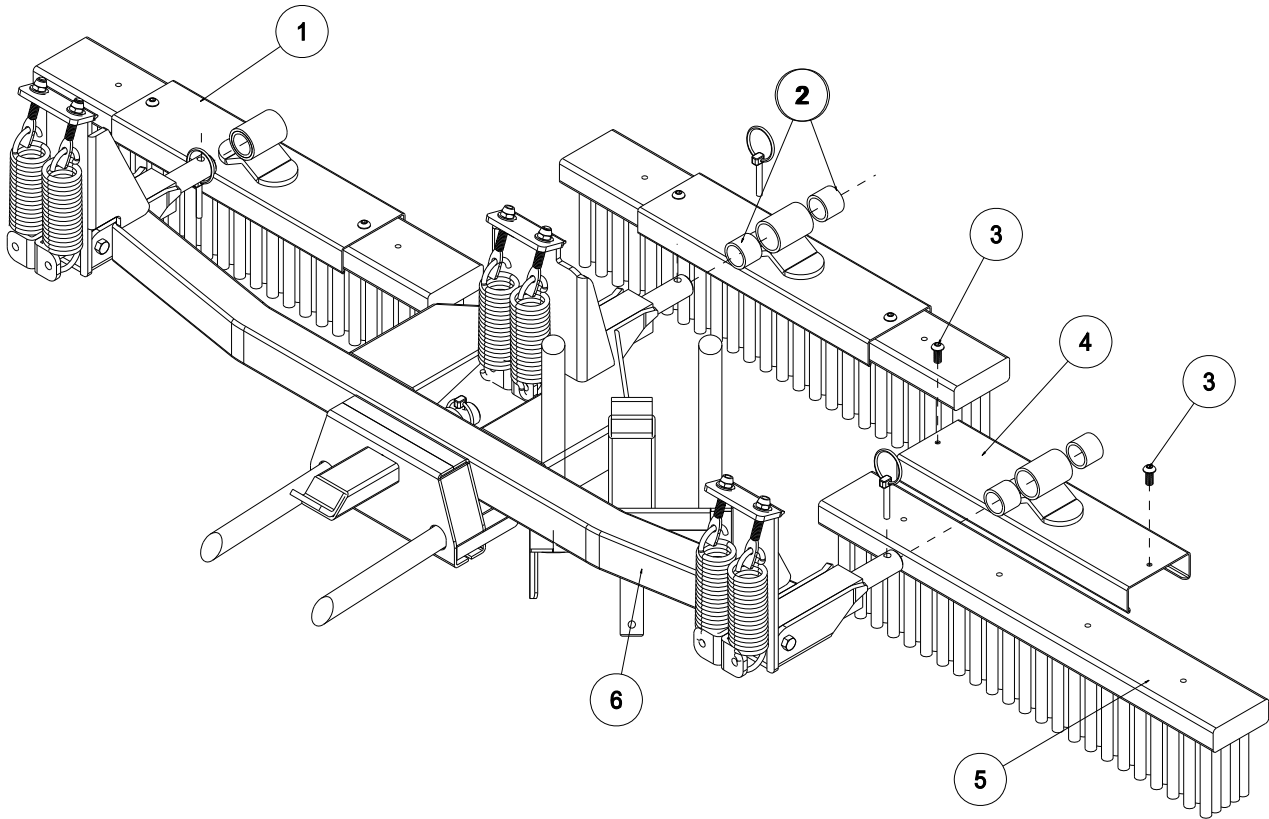

Rear Attachment



## 42-585 GREEN STAR RBS BRUSH SET (3) PARTS LIST

REF#	PART#	DESCRIPTION	QUANTITY
1	42-539	Lynch Pin $\frac{5}{16}$ (part of main frame)	4
2	18-295	Oilite Bushing (part of 42-579)	6
3	HSPP-516-18-075	Phillip Head Screw $\frac{5}{16}$ - 18 x $\frac{3}{4}$	6
4	42-579	Brush Bracket	3
5	42-545	Brush Head	3
6	42-586Q	Green Star RBS Main Frame	1

## ADJUSTMENTS AND OPERATION INSTRUCTIONS

### ADJUSTMENT

The springs are preset for maximum down pressure, and should not need to be adjusted. If you feel the need to adjust the springs please call for further instructions. The unit comes pre-adjusted for most models. The four adjustment holes on the hitch are for making sure all three brushes are touching the ground at the same pressure. When installing brush system start with the lower mounting holes on hitch.

Tire pressure should be 4 psi in the front and 7 psi in the rear tire for best traction.

### OPERATION

Make sure the brush system has been installed and adjusted properly for your model of bunker rake. Always transport in fully raised position. Always remove flag pole before brushing green. Do not stop on green while brushing. Do not brush up steep slopes or loss of traction may result. Do not turn while brushing.

For drag brushes use hydraulics to control the amount of down pressure required to move your top dressing material. We recommend reversing drag brushes after each use for even wear. To begin brushing, lower unit as you come across collar and continue straight across green until reaching other collar and raise as you come off of green. Overlap stripes the same as if you were mowing.

# 42-582 GREEN STAR RBS SPIKER SET (3) DRAWING

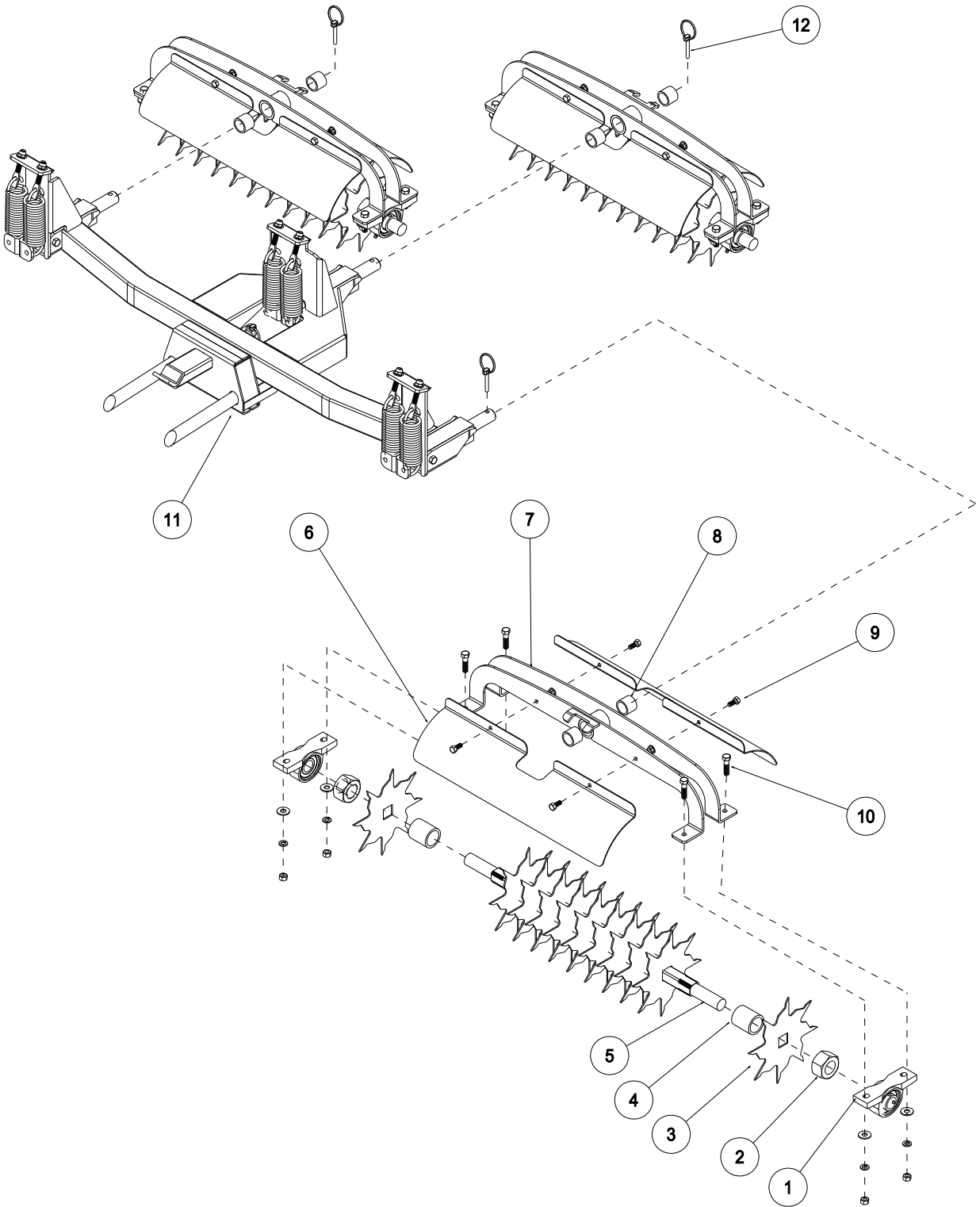

Rear Attachment

## 42-582 GREEN STAR RBS SPIKER SET (3) DRAWING

REF#	PART#	DESCRIPTION	QUANTITY
1	11-094	Pillow Block	6
2	HNJ-114-12	Jam Nut 1 <sup>1</sup> / <sub>4</sub> - 12	6
3	42-583	Spiker Blade	33
4	8965-1.875	Spiker Blade Spacer (1.875")	30
5	42-554	Spiker Shaft	3
6	42-578	Spiker Cover	6
7	42-574	Fork	3
8	18-295	Oilite Bushing (part of 42-574)	6
9	HB-516-18-075	Bolt <sup>5</sup> / <sub>16</sub> - 18 x <sup>3</sup> / <sub>4</sub>	12
	HNTL-516-18	Lock Nut <sup>5</sup> / <sub>16</sub> - 18	12
10	HB-38-16-150	Bolt <sup>3</sup> / <sub>8</sub> - 16 x 1 <sup>1</sup> / <sub>2</sub>	12
	HWL-38	Lock Washer <sup>3</sup> / <sub>8</sub>	12
	HW-38	Washer <sup>3</sup> / <sub>8</sub>	12
	HN-38-16	Nut <sup>3</sup> / <sub>8</sub> - 16	12
11	42-586Q	Green Star RBS Main Frame	1
12	42-539	Lynch Pin <sup>5</sup> / <sub>16</sub> (part of main frame)	3

## ADJUSTMENTS AND OPERATION INSTRUCTIONS

### ADJUSTMENT

The springs are preset for maximum down pressure, and should not need to be adjusted. If you feel the need to adjust the springs please call for further instructions. The unit comes pre-adjusted for most models. The four adjustment holes on the hitch are for making sure all three spikers are touching the ground at the same pressure. When installing spiker system start with the lower mounting holes on hitch.

Tire pressure should be 4 psi in the front and 7 psi in the rear tire for best traction.

### OPERATION

Make sure the spiker system has been installed and adjusted properly for your model of bunker rake. Always transport in fully raised position. Always remove flag pole before spiking green. Do not stop on green while spiking. Do not spike up steep slopes or loss of traction may result. Do not turn while spiking.

To begin spiking, lower unit all the way down as you come across collar and continue straight across green until reaching other collar and raise as you come off of green. Overlap stripes the same as if you were mowing.

### INSTALLATION

Spiker blades must be installed so that the jagged side of the tooth cuts into the turf first. This allows only a piercing of the turf, whereas if the straight edge of the spiker blades enters first it will act more as a cutting effect.

## LIMITED WARRANTY

SMITHCO warrants this product to be free from defects in material and workmanship under normal use for one year from the date of purchase by the original user. (60 days if product is used for rental purposes.) All warranty claims must be handled through a SMITHCO authorized dealer or by SMITHCO, INC. All transportation charges must be paid by the purchaser.

There is no further express warranty. All implied warranties, including those of merchantability and fitness for a particular purpose, are limited to one year, (60 days if product is used for rental purposes) from the date of purchase by the original user, and to the extent permitted by law any and all implied warranties are excluded and disclaimed after the expiration of such period.

All incidental and consequential damages, including pickup and delivery of the unit, communication, mileage charges and/or rental of a replacement unit during repair, are not covered under this warranty, nor is any loss of income and/or other loss resulting from the failure of the product to function due to a warranty defect.

The following items are not covered under the SMITHCO warranty, and are warranted by their respective manufacturer.

- (a) Engine and engine parts, including starters, generators, alternators and filters.
- (b) Transaxle, differentials, gear boxes and mechanical pumps.
- (c) Hydrostatic transmissions, hydraulic pumps and motors.
- (d) Batteries.
- (e) Wheels and tires.

A copy of the warranty for the above items is furnished if necessary with each SMITHCO product.

Some states do not allow limitations on how long an implied warranty lasts, or the exclusion or limitations of incidental or consequential damages, so the above limitations or exclusions may not apply to you. This warranty gives you specific legal rights and you may also have other rights, which may vary from state to state.

Federal law now requires disclosure of the warranty which applies to this product prior to the sale to a customer. Please leave this statement attached to the product and allow the buyer to remove it after purchase.

**SMITHCO**

Wayne, Pennsylvania 19087

