

Parts & Service



*Super Star 3 Wheel Drive
Quick Hitch
42-000-E
SN: 5999*

September 2011

Product Support:

Hwy 55 & Poplar Ave; Cameron WI 54822

1-800-891-9435 productsupport@smithco.com

CONTENTS

Introduction

Introduction	1-3
Introduction	1
Safe Practices	2
Specifications	3

Service

Service	4-11
Maintenance	4-6
Service Chart	7
End User's Service Chart	8
Adjustments	9-11
Storage	11

Diagrams

Diagrams	12-15
Wiring Diagram	12-13
Hydraulic Diagram	14-15

Parts

Parts	16-45
Main Frame	16-17
3 Wheel Drive Front Fork	18-19
Linkage	20-21
Gas Tank	22-23
Oil Tank	24-25
Pump and Engine	26-29
Engine	30-31
Rear Axle	32-33
Rake Lift	34-35
13-729 2-Bank Hydraulic Valve	36-37
42-039 Front Wheel Motor	38-39
42-002 Rear Wheel Motor	40-41
42-302 Electric On-Off Valve	42-45

Accessories

Reference	47-48
Decal List	47
Optional Equipment	47
Quick Reference	48
Warranty	Inside Back Cover

Reference

Thank you for purchasing a **SMITHCO** product.

Read this manual and all other manuals pertaining to the Super Star carefully as they have safety, operating, assembly and maintenance instructions. Failure to do so could result in personal injury or equipment damage.

Keep manuals in a safe place after operator and maintenance personnel have read them. Right and left sides are from the operator's seat, facing forward.

All **SMITHCO** machines have a Serial Number and Model Number. Both numbers are needed when ordering parts. The serial number plate on the Super Star is located on the rear axle. Refer to engine manual for placement of engine serial number.

For easy access record your Serial and Model numbers here.

SMITHCO			CE
WAYNE, PENNSYLVANIA 19087 USA 610-688-4009 Fax 610-688-6069			
SERIAL NO.	kW/hp	DATE OF MFG.	
<input type="text"/>	<input type="text"/>	<input type="text"/>	
MODEL NO.	lb/kg Empty	lb/kg Full	
<input type="text"/>	<input type="text"/>	<input type="text"/>	



Information needed when ordering replacement parts:

1. Model Number of machine
2. Serial Number of machine
3. Name and Part Number of part
4. Quantity of parts

SAFE PRACTICES

1. It is your responsibility to read this manual and all publications associated with this machine (engine, accessories and attachments).
2. Never allow anyone to operate or service the machine or its attachments without proper training and instructions. Never allow minors to operate any equipment.
3. Learn the proper use of the machine, the location and purpose of all the controls and gauges before you operate the equipment. Working with unfamiliar equipment can lead to accidents.
4. Wear all the necessary protective clothing and personal safety devices to protect your head, eyes, ears, hands and feet. Operate the machine only in daylight or in good artificial light.
5. Inspect the area where the equipment will be used. Beware of overhead obstructions and underground obstacles. Stay alert for hidden hazards.
6. Never operate equipment that is not in perfect working order or without decals, guards, shields, or other protective devices in place.
7. Never disconnect or bypass any switch.
8. Carbon monoxide in the exhaust fumes can be fatal when inhaled, never operate a machine without proper ventilation.
9. Fuel is highly flammable, handle with care.
10. Keep engine clean. Allow the engine to cool before storing and always remove the ignition key.
11. After engine has started, machine must not move. If movement is evident, the neutral mechanism is not adjusted correctly. Shut engine off and readjust so the machine does not move when in neutral position.
13. Never use your hands to search for oil leaks. Hydraulic fluid under pressure can penetrate the skin and cause serious injury.
14. This machine demands your attention. To prevent loss of control or tipping of the vehicle:
 - A. Use extra caution in backing up the vehicle. Ensure area is clear.
 - B. Do not stop or start suddenly on any slope.
 - C. Reduce speed on slopes and in sharp turns. Use caution when changing directions on slopes.
 - D. Stay alert for holes in the terrain and other hidden hazards.
15. Before leaving operator's position for any reason:
 - A. Disengage all drives.
 - B. Lower all attachments to the ground.
 - C. Shut engine off and remove the ignition key.
16. Keep hands, feet and clothing away from moving parts. Wait for all movement to stop before you clean, adjust or service the machine.
17. Keep the area of operation clear of all bystanders.
18. Never carry passengers.
19. Stop engine before making repairs/adjustments or checking/adding oil to the crankcase.
20. Use parts and materials supplied by SMITHCO only. Do not modify any function or part.

These machines are intended for professional maintenance on golf courses, sports turf, and any other area maintained turf and related trails, paths and lots. No guaranty as to the suitability for any task is expressed or implied.



WEIGHTS AND DIMENSIONS

Length	64" (1.63 m)
Width	57" (1.45 m)
Height	47" (1.19 m)
Wheel Base	41" (1.04 m)
Weight	950 lbs. (451 kg)

SOUND LEVEL

At Ear Level	84 dB
--------------	-------

ENGINE

Make	Briggs and Stratton Vanguard
Model#	305447
Type / Spec#	0230 G1
Horsepower	16 hp (12 kW)
Fuel	Unleaded 87 Octane Gasoline Minimum
Cooling System	Air Cooled
Lubrication System	Full Pressure
Alternator	16 amp

WHEELS & TIRE

Three: 22 X 11 - 10.0 Knobby Tires 8 psi (.55 bar)
 Front tire fluid filled to 80 lbs. total 45.5 pints of windshield washer fluid or equivalent.

Speed

Forward Speed	0 to 11 m.p.h. (0-18 kph)
Reverse Speed	0 to 5 m.p.h. (0-8 kph)

BATTERY

	Automotive Type 45-12 Volt
BCI Group	Size 45
Cold Cranking Amps	480
Ground Terminal Polarity	Negative (-)
Maximum Length	9" (23 cm)
Maximum Width	5.38" (14 cm)
Maximum Height	9" (23 cm)

FLUID CAPACITY

Crankcase Oil	See Engine Manual
Fuel	20 quarts (18.93 liters)
Hydraulic Fluid	20 quarts (18.93 liters)
Grade of Hydraulic Fluid	SAE 10W-40 API Service SJ or higher Motor Oil

MAINTENANCE



Before servicing or making adjustments to machine, stop engine and remove key from ignition.

NOTE:

Use all procedures and parts prescribed by the manufacturer's. Read the engine manual.

LUBRICATION

Use No. 2 General purpose Lithium Base Grease and lubricate every 100 hours. The Super Star has three grease fittings. One is located on the shift idler arm, one on the rod end of the attachment lift cylinder and one is located on the steering chain tensioner. Access to the steering chain tensioner is available through the plugs located on the right side of the nosecone..

AIR CLEANER ON ENGINE

1. Unhook clips on both sides of cover and remove cover.
2. Carefully slide pre-cleaner of cartridge. To service pre-cleaner, wash in liquid detergent and water. Squeeze dry in clean cloth. Saturate in engine oil. Squeeze in clean absorbent cloth to remove excess oil. Replace if very dirty or damaged.
3. Remove knob and plate. Carefully remove cartridge to prevent debris from entering carburetor. To service cartridge, clean by tapping gently on flat surface. Do not oil cartridge. Replace if very dirty or damaged.

NOTE:

Do not use petroleum solvents, e.g., kerosene, which will cause cartridge to deteriorate. Do not use pressurized air to clean cartridge. Pressurized air can damage cartridge.

4. Reinstall cartridge, plate and knob.
5. Reassemble pre-cleaner on cartridge.
6. Replace cover and reattach clips to body.

REMOTE AIR CLEANER

1. Unclip the two clips, remove the cover and pull out the element.
2. To service, clean by tapping gently on flat surface. Do not oil. Replace if very dirty or damaged.
3. Clean out the inside of the body and cover.
4. Place the element into the body and put the cover back on.

TOWING

When it is necessary to move the Super Star without engine running, bypass valve built into hydrostatic pump must be "open" by turning it counterclockwise. The valve is located on the right side of the pump. An "open" valve allows fluid to pass through the wheels freely. When normal, driven, operation is desired, valve should be "closed" by turning it clockwise. Failure to "close" the valve with engine running means no power to wheels. The machine can be moved for a short distance with the engine off, but we **do not** recommend this as a standard procedure. When towing **do not** tow the machine faster than 2-3 MPH (3-5 km/h) because the drive system may be damaged. The tires may lock up if the machine is towed too fast. If this occurs, stop towing the machine. If the machine must be moved a considerable distance, transport it on a truck or trailer.



TIRE PRESSURE

Caution must be used when inflating a low tire to recommended pressure. Over inflating can cause tires to explode. Tires should be 8 psi (0.55 bar). Improper inflation will reduce tire life considerably.

ENGINE

Change and add oil according to chart below. Do not overfill. Use a high quality detergent oil classified "For Service SJ or higher" SAE 30 oil. Use no special additives with recommended oils. Do not mix oil with gasoline.

SAE VISCOSITY GRADES

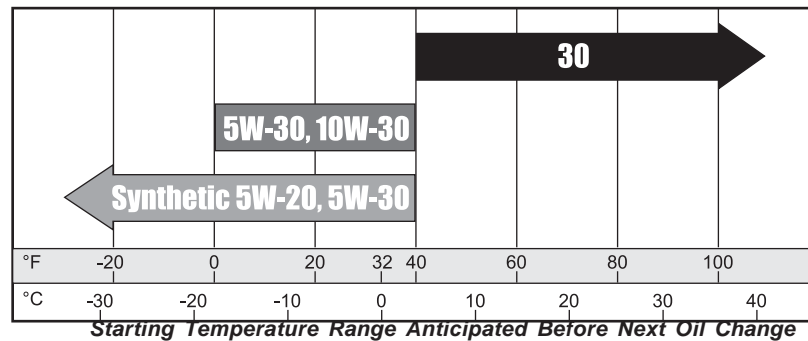

Air cooled engine run hotter than automotive engines. Use of multi-viscosity oils (10W-30, etc.) above 40° F (4° C) will result in high oil consumption and possible engine damage. Check oil level more frequently if using these types of oils.

SAE 30 oil, if used below 40° F (4° C), will result in hard starting and possible engine bore damage due to inadequate lubrication.

HYDRAULIC OIL

1. Use SAE 10W-40 API Service SJ or higher motor oil.
2. For proper warranty, change oil every 500 hours or annually, which ever is first and change filter after the first 20 hours, then at 100 hours, then every 250 hours thereafter.
3. The oil level should be 2" to 2 1/2" from top of tank when fluid is cold. Do not overfill.
4. After changing oil and/or filter, run the machine for a few minutes. Check oil level and for leaks.
5. Always use caution when filling hydraulic oil tank or checking level to keep system free of contaminants. Check and service more frequently when operating in extremely cold, hot or dusty conditions.
6. If natural color of fluid is black or smells burnt, it is possible that an overheating problem exists.
7. If fluid becomes milky, water contamination may be a problem.
8. If either of the above conditions happen, change oil and filter immediately after fluid is cool and find cause. Take fluid level readings when system is cold.
9. In extreme temperatures you can use straight weight oil. We recommend SAE 30W API Service SJ or higher when hot (above 90°F (33°C)) and SAE 10W API Service SJ or higher when cold (below 32°F (0°C) ambient temperature. Use either motor oil or hydraulic oil, but do not mix.
10. Oil being added to the system must be the same as what is already in the tank. Mark tank fill area as to which type you put in.

MAINTENANCE

WHEEL MOUNTING PROCEDURE

1. Turn machine off and remove key.
2. Block one of the other wheels.
3. Loosen nuts slightly on wheel to be removed.
4. Jack up machine being careful not to damage underside of machine.
5. Remove nuts. Remove wheel.
5. Place new wheel on hub lining up bolt holes.
6. Torque nuts to 64-74 ft/lb (87-100 Nm) using a cross pattern. Re-torque after first 10 hours and every 200 hours thereafter.
7. Lower machine to ground and remove blocks and jack.

BATTERY

Batteries normally produce explosive gases which can cause personal injury. Do not allow flames, sparks or any ignited object to come near the battery. When charging or working near battery, always shield your eyes and always provide proper ventilation.

Battery cable should be disconnected before using "Fast Charge".

Charge battery at 15 amps for 10 minutes or 7 amps for 30 minutes. Do not exceed the recommended charging rate. If electrolyte starts boiling over, decrease charging.

Always remove grounded (-) battery clamp first and replace it last. Avoid hazards by:

1. Filling batteries in well-ventilated areas.
2. Wear eye protection and rubber gloves.
3. Avoid breathing fumes when electrolyte is added.
4. Avoid spilling or dripping electrolyte.



WARNING

Battery Electrolyte is an acidic solution and should be handled with care. If electrolyte is splashed on any part of your body, flush all contact areas immediately with liberal amounts of water. Get medical attention immediately.

JUMP STARTING



WARNING

Use of booster battery and jumper cables. Particular care should be used when connecting a booster battery. Use proper polarity in order to prevent sparks.

To jump start (negative grounded battery):

1. Shield eyes.
2. Connect ends of one cable to positive (+) terminals of each battery, first (A) then (B).
3. Connect one end of other cable to negative (-) terminal of "good" battery (C).
4. Connect other end of cable (D) to engine block on unit being started (NOT to negative (-) terminal of battery)

To prevent damage to other electrical components on unit being started, make certain that engine is at idle speed before disconnecting jumper cables.

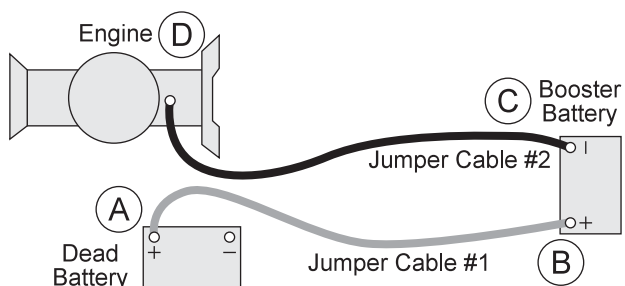



Before servicing or making adjustments to the machine, stop engine, set park break, block wheels and remove key from ignition.



Follow all procedures and **ONLY** use parts prescribed by the manufacturer. Read the engine manual before maintenance.

	Daily	As Required	100 Hours	200 Hours	250 Hours	300 Hours	400 Hours	Every 500 Hours/Yearly
⌘ Engine Oil	C	R	R	R	R	R	R	R
⌘ Engine Oil Filter			R	R		R	R	R
Engine for Leaks and Loose Parts	C		C	C		C	C	C
‡ Air Cleaner (Paper Element)		R	C	C		C	C	R
‡ Pre-Cleaner (Every 25 hours)		R	C	C		C	C	R
Spark Plugs							C	R
Valve Clearance								C
Idle Speed		C						C
Air Cooling System	C		C	C		C	C	C
Hoses	C				C			C
* Tire Pressure	C		C	C		C	C	C
Visual Inspection of Tires	C		C	C		C	C	C
Fuel Level	C	C						
Fuel Filter		R						R
Hydraulic Oil	C		C	C		C	C	R
† Hydraulic Oil Filter					R			R
Hydraulic System for Leaks and Loose Parts	C		C	C		C	C	C
Battery Electrolyte Level			C	C		C	C	C
Clean Battery Terminals					C			C
§ Torque Lug Nuts				C			C	C
Belt Tension and Visual Inspection			C	C		C	C	C
Lubricate			C	C		C	C	C

C=Check or Clean at specified intervals

R=Replace at specified intervals

* Tire pressure: 8 psi (0.55 bar)

† Replace hydraulic filters after the first 20, 100, and every 250 there after.

§ Torque tire nuts after the first 10 hours and every 200 hours there after (64 to 74 ft/lb (87-100 Nm))

⌘ Change Oil and Filter after first 8 hours.

⌘ Change oil every 25 hours when operating under heavy load or in high ambient temperatures.

‡ Clean more often under dusty conditions or when airborne debris is present, replace air cleaner parts, if very dirty.

The suggested maintenance checklist is not offered as a replacement for the manufacturer's engine manual but as a supplement. You must adhere to the guidelines established by the manufacturer for warranty coverage. In adverse conditions such as dirt, mud or extreme temperatures, maintenance should be more frequent.



END USER'S SERVICE CHART

Service

	Daily	As Required	25 Hours	50 Hours	100 Hours	200 Hours	250 Hours	Every 500 Hours/Yearly
£ Engine Oil (Change every 50 hours)								
¤ Engine Oil Filter								
Engine for Leaks and Loose Parts								
‡ Air Cleaner (Paper Element)								
‡ Pre-Cleaner (Every 25 hours)								
Spark Plugs								
Valve Clearance								
Idle Speed								
Belt Tension and Visual Inspection								
Air Cooling System								
Hoses								
*Tire Pressure								
Visual Inspection of Tires								
Fuel Level								
Fuel Filter								
†Hydraulic Oil								
Hydraulic System for Leaks and Loose Parts								
Battery Electrolyte Level								
Clean Battery Terminals								
§Torque Lug Nuts								
Lubricate								

C=Check or Clean at specified intervals

R=Replace at specified intervals

* Tire pressure: 8 psi (0.55 bar)

† Replace hydraulic filters after the first 20, 100, and every 250 there after.

§ Torque tire nuts after the first 10 hours and every 200 hours there after (64 to 74 ft/lb (87-100 Nm))

¤ Change Oil and Filter after first 8 hours.

£ Change oil every 25 hours when operating under heavy load or in high ambient temperatures.

‡ Clean more often under dusty conditions or when airborne debris is present , replace air cleaner parts, if very dirty.



RAKE LIFT CYLINDER

Completely lower Rake Lift. Remove the clevis pin (A). Twist lift linkage (C) so clevis pin end of cylinder extension lines up with holes in attachment lift arm. Replace clevis and cotter pins. Raise and lower Rake Lift to check for proper clearance.



When the rear rake attachment is lowered while the machine is in forward motion, the forward speed of the machine will slow drastically. Operator should be prepared for a rapid change in speed.

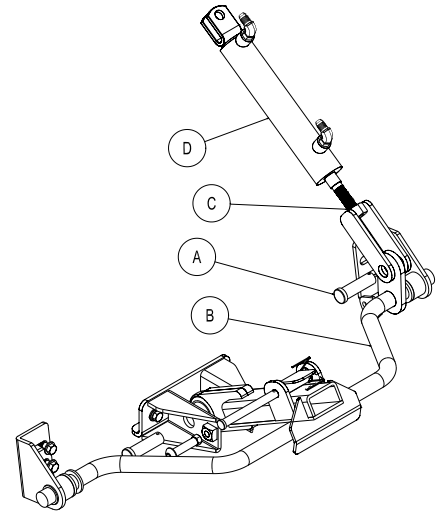

STEERING CHAIN ADJUSTMENT

You will have to remove the nose cone assembly to get at steering sprockets. Steering Sprockets (A) should be level with each other. Check with straight edge. Make any adjustments. Adjust the chain tensioner bolt (B) so that the chain is snug. Tighten all nuts and bolts in place.

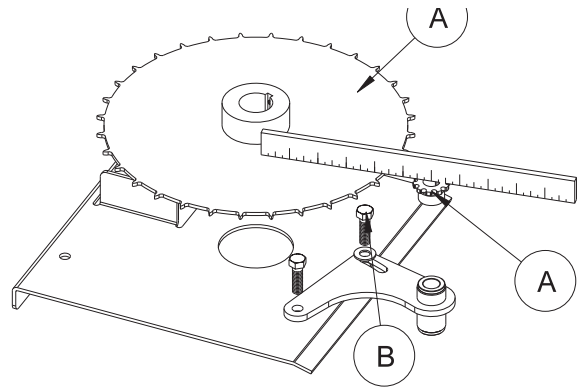

SPEED BOSS

Speed Boss allows the machine to operate at a proper speed while raking sand traps on golf courses. This speed boss has been factory set at an average speed of 3-4 m.p.h. (5-6.5 kph). The Speed Boss will only limit the speed while the rake is lowered into the operating position. The speed setting may be adjusted by turning the Ball Joint (A) counterclockwise to make the machine operate slower or turn clockwise to go faster. Tighten jam nut. Check to make sure nothing is binding and test drive to check desired speed.

For RBS System, Spiker and Grader Box remove the speed boss arm and the speed boss rod from machine so it does not interfere with other operations.

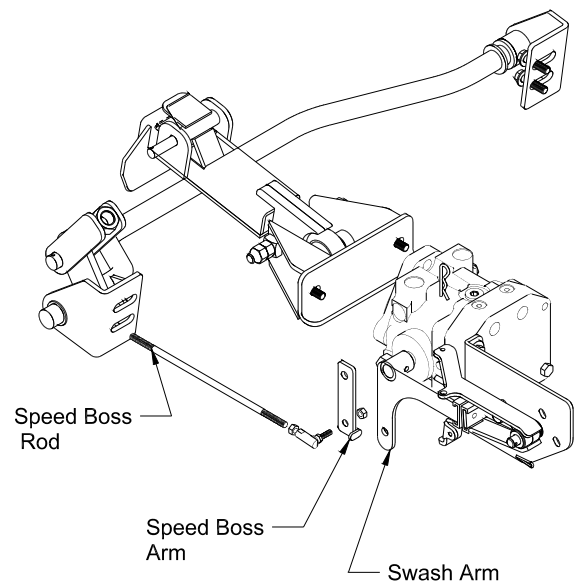

ADJUSTMENTS (CONTINUED)

WHEEL 'CREEP' ADJUSTMENT

'Creep' is when engine is running and hydrostatic transmission is in neutral, but due to inadequate alignment, wheels still move. Do the following procedures to stop this motion.

1. Lift up and support machine so all wheels are off the ground and can turn freely.
2. On the side of the pump there is a creep arm inside a centering arm. Loosen bolt (A).
3. With engine running adjust the creep arm up or down in slot so centering arm centers on the swash arm.
4. Tighten all fasteners and test by using foot pedal linkage to see that the "creep" is removed.
5. Turn engine off and lower machine.

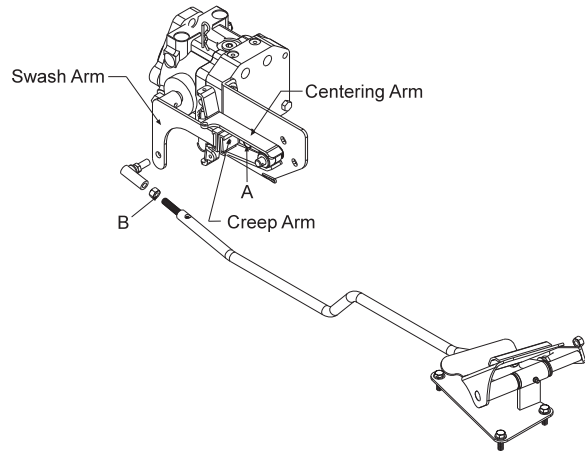

PARK BRAKE

The park brake is located on the right hand side of the machine and operates a brake on the right rear wheel. Push lever forward to engage and pull back to disengage.

To adjust turn the knob on the end of the handle. For further adjustment you may turn the yokes (A) clockwise to tighten and counter clockwise to loosen.

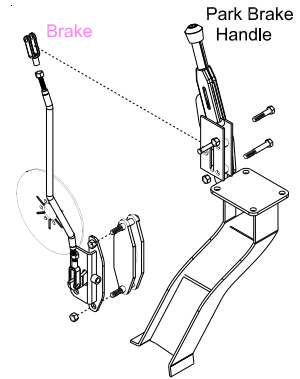

ADJUSTMENT OF BELT TENSIONER

The belt tensioner controls the tension on the belt from the engine to the pump. The proper tension of the idler should be in the second notch on the side of the tensioner. Over tightening the belt will shorten the life of the belt and the machine may not perform to the best of its ability. To adjust belt tensioner, loosen the bolt holding the tensioner (A). Bring idler pulley tight to the belt and turn tensioner into belt to the second notch. Tighten bolt on tensioner.

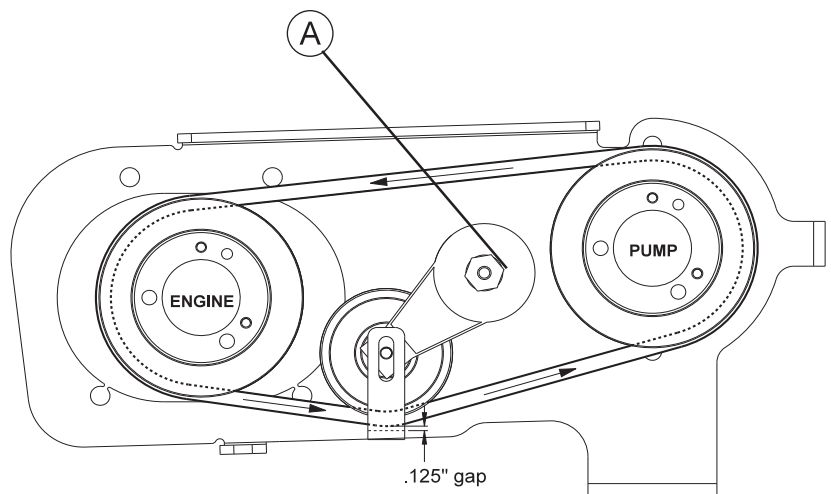

Belt Routing

ADJUSTMENTS (CONTINUED)

TO ADJUST FOOT PEDAL THROTTLE CABLE

1. Jack up unit so that all drive wheel are off the ground. (Use jack stands)
2. Start the engine, make certain that the hand throttle is in the idle position (1200 engine RPM).
3. Engine speed must increase as soon as the foot pedal begins to move in either direction. At the full forward position, the engine RPM must be 3600 RPM \pm 100.
4. Minor adjustment can be made by backing out (unscrewing) (Ref A) until you reach full engine RPM with the foot pedal fully depressed in the forward position. Be sure to recheck after the nuts are fully tightened.
5. Major adjustment needs to be made at (Ref B) by pulling the slack out of the cable. Loosen the screw in the wire block that is clamped onto the end of the cable and sliding it up to the cable block that is through the throttle plate. Do not let the throttle plate move to increase idle speed. Tighten the screw.
6. Test run to determine that there is no binding and that engine idle speed is 1200 RPM and that it is 3600 RPM at full forward position of the foot pedal.

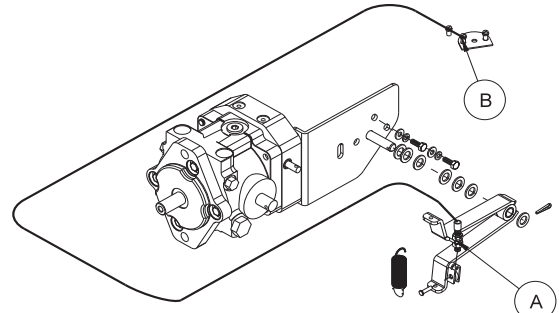

Service

STORAGE

When storing, remove the key from the key switch to avoid unauthorized persons from operating machine.

1. Before storing clean machine thoroughly.
2. Check bolts and nuts, tighten as necessary.
3. Make all repairs that are needed and remove any debris.
4. Remove the battery, adjust the electrolyte level and recharge it. Store the battery in a dry, dark place.
5. Store in a clean and dry area, but NOT near a stove, furnace or water heater which uses a pilot light or any device that can create a spark.
6. Engines stored over 30 days need to be protected or drained of fuel to prevent gum from forming in a fuel system or on essential carburetor parts. Check the engine manual and follow the instructions for the storage of the engine.

WIRING DRAWING

Color Code Chart

Bl	Blue
Br	Brown
Y	Yellow
Grn	Green
O	Orange
R	Red
B	Black
P	Purple
W	White

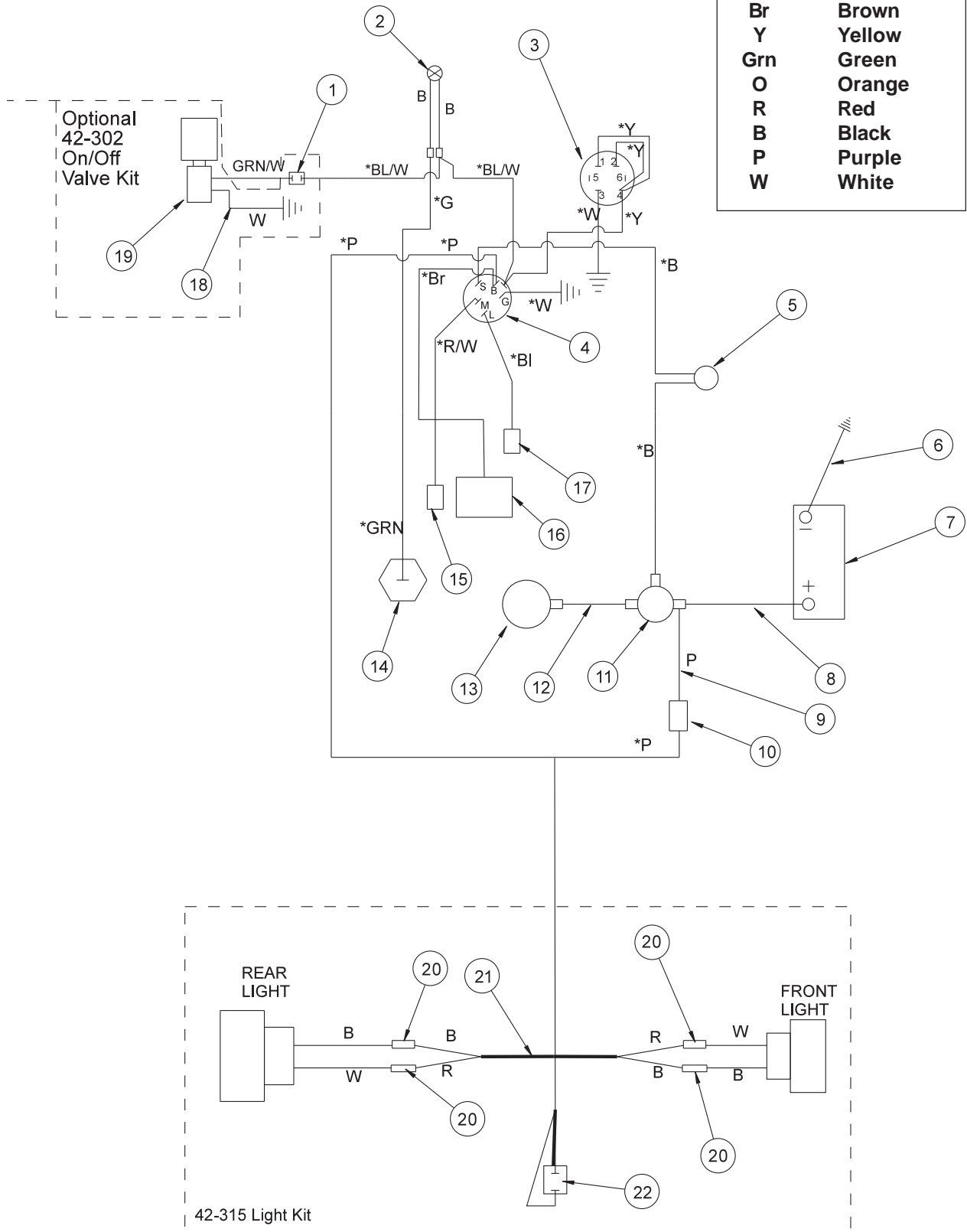

Diagrams

WIRING PARTSLIST

REF #	PART #	DESCRIPTION	QUANTITY
1	12-003	Toggle Switch (part of 42-302 Kit)	1
	15-472	Switch Boot	1
2	50-359	Oil Pressure Warning Light	1
3	12-017	Hour/ Volt Meter Combo	1
4	13-488	Ignition Switch (B & S# 692318)	1
	76-310	Key Set (comes with 13-488)	1
5	14-292	Seat Switch	1
6	76-327	Ground Battery Cable	1
7		Battery (not included)	
8	75-518	Battery Cable	1
9	42-252	Wire, Circuit Breaker to Solenoid	1
10	8975	30 Amp Circuit Breaker	1
	8977	Circuit Breaker Boot	1
11	13-748	Solenoid	1
	13-749	Push on Connector	1
12	22-017	Cable Black	1
13		Starter (on engine)	1
14	13-491	Oil Sender (on engine B & S# 491657)	1
15		Stop Switch Terminal (on engine)	1
16		Rectifier (on engine)	1
17		After Fire Solenoid (on engine)	1
18	76-260	Ground Wire (part of 42-302 Kit)	1
19	42-118	Electric On/Off Valve (part of 42-302 Kit)	1
	42-763	Wire Harness (includes all wire colors with *)	1
	42-387	Wire Harness Solenoid to ENgine	1

HYDRAULIC PARTSLIST

REF #	PART #	DESCRIPTION	QUANTITY
1	42-039	Front Wheel Motor (3 wheel drive only)	1
2	42-262	Hydraulic Hose (3 wheel drive only)	2
3	10-554	Hydraulic Cylinder	1
	18-154	Rod End	1
	HNJ-58-18	Jam Nut $\frac{5}{8}$ - 18	1
4	42-047	Hydraulic Hose	2
5	13-729	2 - Bank Hydraulic Valve	1
	78-417	Valve Handle	2
6	42-048	Hydraulic Hose	2
7	43-150	Hydraulic Cylinder	1
8	42-044	Hydraulic Hose	1
9	18-342	Cross	2
10	42-818	Hydraulic Hose	4
11	42-002	Rear Wheel Motor	2
12	42-259	Hydraulic Hose 10 $\frac{3}{4}$ "	1
15	42-599	Variable Pump	1
16	42-258	Hydraulic Hose 9"	1
17	8832-45	Suction Hose	1
	18-222	Hose Clamp	2
18	42-787	Hydraulic Hose	1
19	23-006	Oil Filter	1
	23-031	Replacement Filter Only	
20	8832-24	Suction Hose	1
	18-222	Hose Clamp	2
21	42-005	Oil Tank	1
	13-747	Filler Breather	1
22	42-256	Hydraulic Hose	1
23	42-265	Aluminum Oil Cooler	1
24	42-045	Hydraulic Hose	1
42-302 ELECTRIC ON/OFF VALVE KIT			
25	42-263	Hydraulic Hose	2
26	76-260	Ground Wire	1
27	42-264	Hydraulic Hose	2
28	42-118	Electric On/Off Valve	1
29	18-185	Elbow 90°	1
30	18-341	Elbow 45°	3
HYDRAULIC PLOW			
31	14-534	Hydraulic Cylinder	1
32	43-049	Hydraulic Hose 18"	1
34	43-048	Hydraulic Hose 20"	1
35	13-731	Single Bank Valve	1
HYDRAULIC PRESSURES			
Pump Displacement	.913 in ³ /rev	Charge Pump Displacement	.33 in ³ /rev
Pump Input Speed (up to)	3600 rpm	Max. Inlet Vacuum	5 in. Hg
Max. Operating Pressure	2500 psi	Max. Case Pressure	25 psi
Implement Setting	700-1000 psi	Relief Valve Pressure (set at)	2500 psi
13-729 Hydraulic Valve (2 bank)	900 psi		

Diagrams

MAINFRAME DRAWING

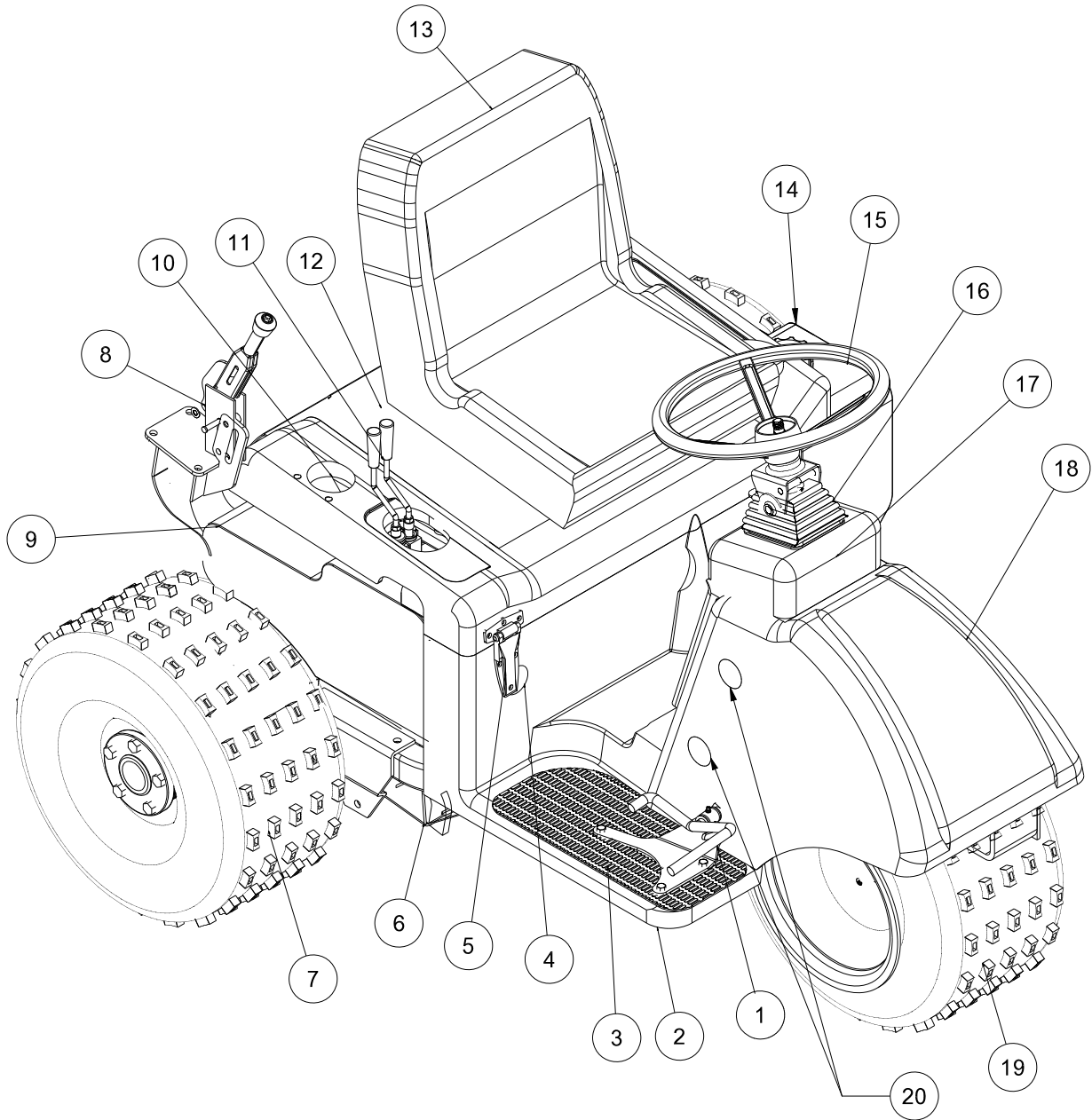

Parts

MAIN PARTS LIST

REF#	PART#	DESCRIPTION	QUANTITY
1	42-813	Foot Pedal	1
2	42-780	Floor Panel (fiberglass)	1
3	42-767	Right Floor Mat	1
	42-768	Left Floor Mat	1
4	12-017	Hour Meter	1
5	27-055	Hinge	2
6	42-605	Main Frame	1
7	42-161	Knobby Tire and Wheel	2
	42-161-01	Tire 22 x 11 - 10 Knobby Type	2
	42-161-02	Wheel	2
8	60-106	Park Brake Lever	1
9	42-814	Gas Tank	1
10	42-786	Plastic Cup Holder	1
11	78-418	Valve Handle	2
12	42-772	Seat Panel	1
	8803-17	Trim w/ Black Lace	1
13	14-269	Adjustable Low Back Seat	1
14	42-779	Seat Panel (fiberglass)	1
15	13-718	Steering Wheel	1
16	76-364	90° Black Boot (comes with 76-362)	1
	76-362	Tilt Steering Mechanism	1
17	42-782	Console (fiberglass)	1
18	42-471	Nose Cone (fiberglass)	1
	HSTP-14-20-100	Truss Head Screw 1/4 - 20 x 1	6
	78-274	Cage Nuts	2
	HNTL-14-20	Lock Nut 1/4 - 20	4
19*	42-161	Knobby Tire and Wheel	1
	42-161-01	Tire 22 x 11 - 10 Knobby Type	1
	42-161-02	Wheel	1
20	18-436	Plastic Cap Plug	2

* Front tire and wheel are fluid filled to 80 lbs. total.
 8839 Windshield Washer Fluid or Equivalent 45.5 pints

3 WHEEL DRIVE FRONT FORK DRAWING

DO NOT OVER GREASE.
 OVER GREASING WILL CAUSE
 PRE-MATURE SEAL DAMAGE THAT IS
 A NON-WARRANTABLE SITUATION.
 SEMI-ANNUAL GREASING RECOMMENDED.

11-038 BEARING W/ RACER (2)
 11-039 OIL SEAL (2)
 GREASE ZERK
 13-744
 CHAIN TENSIONER

HWK-316-063

HP-18-150

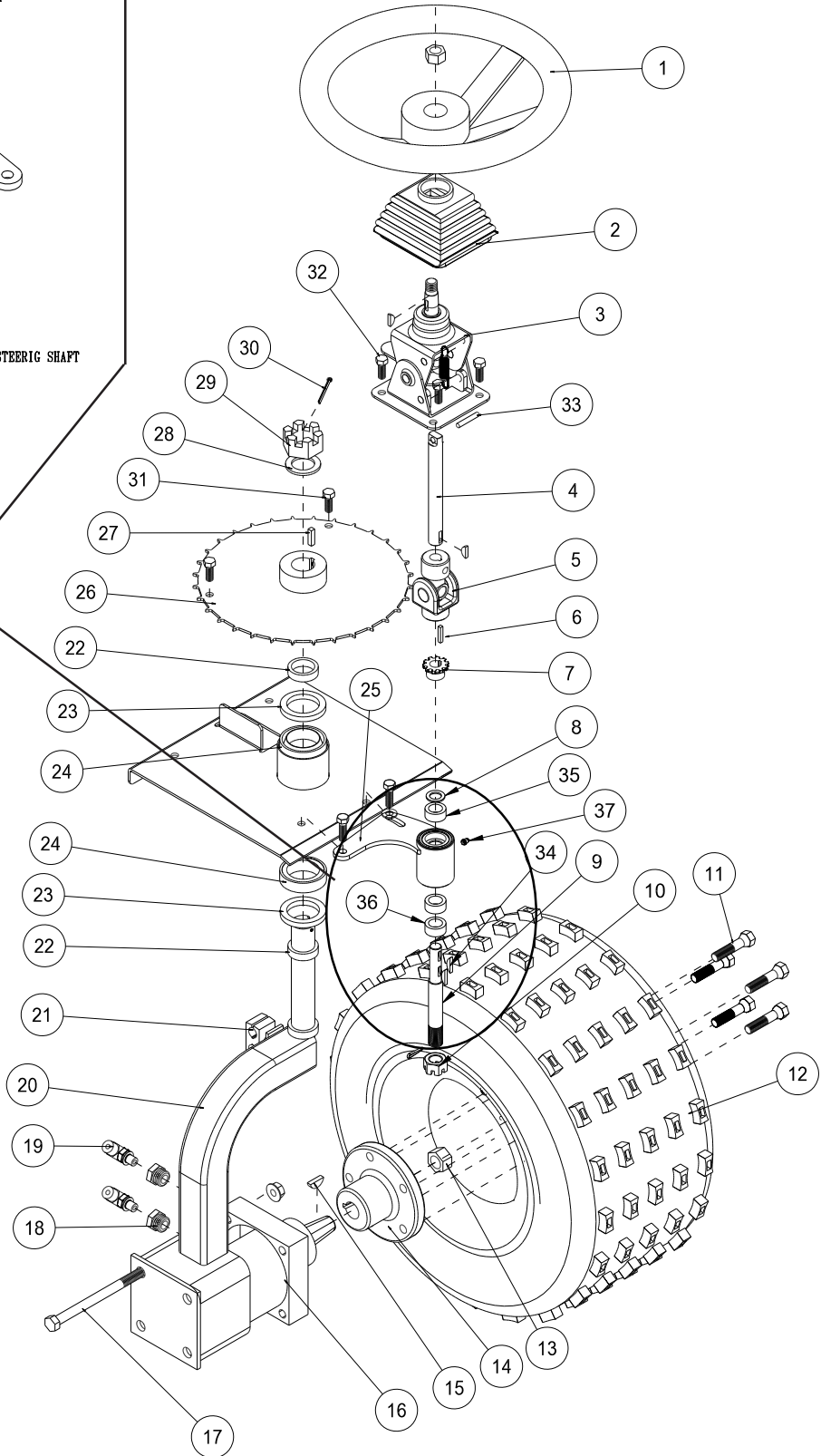
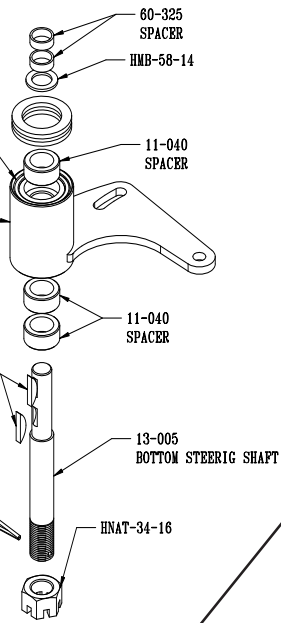

Parts

3 WHEEL DRIVE FRONT FORK PARTSLIST

REF#	PART#	DESCRIPTION	QUANTITY
1	13-718	Steering Wheel 13"	1
	13-726	Center Cap	1
	27-077	Decal, Smithco Round	1
	HNJ-58-11	Jam Nut $\frac{5}{8}$ - 11	1
	HWK-316-075	Woodruff Key $\frac{3}{16} \times \frac{3}{4}$	1
2	76-364	Tilt Steering Boot (comes with 76-362)	1
3	76-362	Tilt Steering Mechanism	1
4	42-760	Top Steering Shaft	1
	HWK-316-075	Woodruff Key $\frac{3}{16} \times \frac{3}{4}$	1
5	60-300	U-Joint	1
6	HKSQ-316-100	Machine Key $\frac{3}{16} \times \frac{3}{16} \times 1$	2
7	60-298	Sprocket	1
8	HMB-58-14	Machine Bushing $\frac{5}{8} \times 14$ GA	1
9	13-005	Bottom Steering Shaft	1
10	HNAT-34-16	Axle Nut $\frac{3}{4}$ - 16	1
	HP-18-150	Cotter Pin $\frac{1}{8} \times 1\frac{1}{2}$	1
11	60-268	Lug Bolts $\frac{1}{2}$ - 20 x $1\frac{5}{16}$	5
12	42-161	Knobby Tire and Wheel	1
	42-161-01	Tire 22 x 11 - 10 Knobby Type	1
	42-161-02	Wheel	1
	8839	Windshield Washer Fluid or Equivalent	43.5 pints
13	42-002-12	Nut $\frac{3}{4}$ - 16 (part of 42-039)	1
14	42-007	Hub	1
15	HWK-14-100	Woodruff Key $\frac{1}{4}$ - 1 (part of 42-039)	1
16	42-039	Wheel Motor	1
	18-350	90° Seal Lok Elbow	2
17	HB-12-13-650	Bolt $\frac{1}{2}$ - 13 x $6\frac{1}{2}$	4
	HNTL-12-13	Lock Nut $\frac{1}{2}$ - 13	4
18	18-172	Reducer	2
19	18-171	Seal Lock Elbow	2
20	42-022	Front Fork	1
21	13-652	Hose Clamp	1
22	20-141	Spacer	2
23	20-142	Oil Seal	2
24	20-143	Bearing	2
25	13-744	Chain Tensioner	1
	11-038	Bearing with Race	2
	11-039	Oil Seal	2
	HB-38-16-125	Bolt $\frac{3}{8}$ - 16 x $1\frac{1}{4}$	2
	HW-38	Washer $\frac{3}{8}$	1
	HNFL-38-16	Flange Whiz Lock Nut $\frac{3}{8}$ - 16	2
26	42-295	Steering Sprocket	1
	8834-37.5	#35 Roller Chain	1
	18-114	Master Link	1
27	HKSQ-14-100	Square Key $\frac{1}{4} \times \frac{1}{4} \times 1$	1
28	HMB-114-10	Machine Bushing $1\frac{1}{4} \times 10$ GA	1
29	HNA-114-12	Axle Nut $1\frac{1}{4}$ - 12	1
30	HP-18-200	Cotter Pin $\frac{1}{8} \times 2$	1
31	HB-38-16-100	Bolt $\frac{3}{8}$ - 16 x 1	2
	HNFL-38-16	Flange Whiz Lock Nut $\frac{3}{8}$ - 16	2
32	HB-516-18-125	Bolt $\frac{5}{16}$ - 18 x $1\frac{1}{4}$	2
	HNTL-516-18	Lock Nut $\frac{5}{16}$ - 18	2
33	HRP-14-150	Roll Pin $\frac{1}{4} \times 1\frac{1}{2}$	1
34	HWK-316-063	Woodruff Key $\frac{3}{16} \times \frac{5}{8}$	2
35	60-325	Spacer	1
36	11-040	Spacer	2
37	HG-14-28-180	Grease Zerk	1

LINKAGE DRAWING

Parts

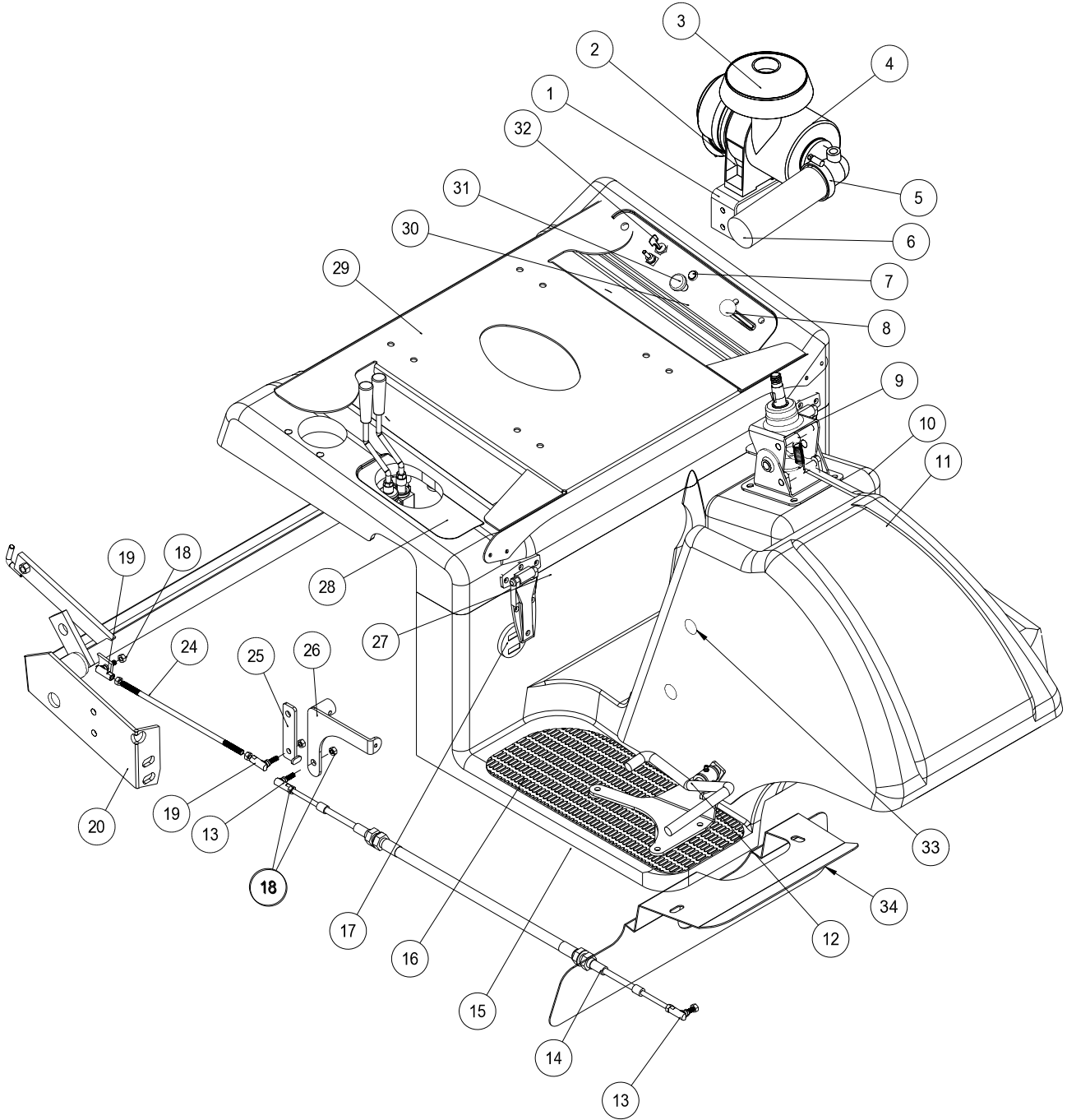

LINKAGE PARTSLIST

REF#	PART#	DESCRIPTION	QUANTITY
1	42-769	Oil Tank Bracket	1
	HB-516-18-100	Bolt ⁵ / ₁₆ - 18 x 1	2
	HNFL-516-18	Flange Whiz Lock Nut ⁵ / ₁₆ - 18	2
2	42-076-01	Band	1
3	42-076-02	Hat	1
4	42-076	Air Cleaner	1
	42-076-03	Replacement Filter	
	13-603	Air Cleaner Base (comes with engine)	1
5	18-123	Hose Clamp	2
6	8959-26	Flex Hose x 26"	1
	27-113	Air Cleaner Hose Elbow	1
	42-776	Air Cleaner Hose Sleeve	1
7	50-359	Warning Light	1
8	42-789	Throttle Cable	1
	42-766	Throttle Bracket	1
	HSTP-14 -20-075	Phillips Truss Head Screw ¹ / ₄ - 20 x ³ / ₄	2
	HNFL-14-20	Flange Whiz Lock Nut ¹ / ₄ - 20	2
9	76-362	Tilt Steering	1
	76-364	Boot Black (comes with 76-362)	1
10	42-782	Console (fiberglass)	1
11	42-471	Nose Cone (fiberglass)	1
12	42-813	Foot Pedal	1
	HG-14-28-180	Grease Fitting ¹ / ₄ - 28 x 180° (comes with 42-790)	1
	76-299	Pedal Pad Long	1
	42-791	Pedal Pad Short	1
	HB-516-18-150	Bolt ⁵ / ₁₆ - 18 x 1 ¹ / ₂	2
	HW-516	Washer ⁵ / ₁₆	2
	HNFL-516-18	Flange Whiz Lock Nut ⁵ / ₁₆ -18	2
13	8-701	Ball Joint ¹ / ₄ - 28	2
14	27-132	Cable	1
15	42-780	Floorboard (fiberglass)	1
16	42-767	Right Floor Mat	1
	42-768	Left Floor Mat	1
17	12-017	Hour Meter	1
18	HN-14-28	Nut ¹ / ₄ -28	4
	HWL-14	Lockwasher ¹ / ₄	2
19	18-387	Spring Loaded Ball Joint ⁵ / ₁₆ - 24	2
20	43-137	Lift Bar	1
24	43-147	Speed Boss Rod	1
25	42-249	Speed Boss Arm	1
26	42-308	Swash Arm	1
27	27-055	Hinge	2
	HSMFCS-10-32-100	Machine Screw #10 - 32 x 1	12
	HNFL-10-32	Flange Lock Nut #10 - 32	12
28	42-765	Decal, Lift Controls	1
29	42-779	Seat Panel	1
30	42-593	Decal, Control Panel	1
31	42-783	Choke	1
32	13-488	Key Switch (B&S 692318)	1
	76-310	Key Set	1
33	18-436	Plastic Cap Plug	2
34	42-590	Mud Guard	1

GAS TANK DRAWING

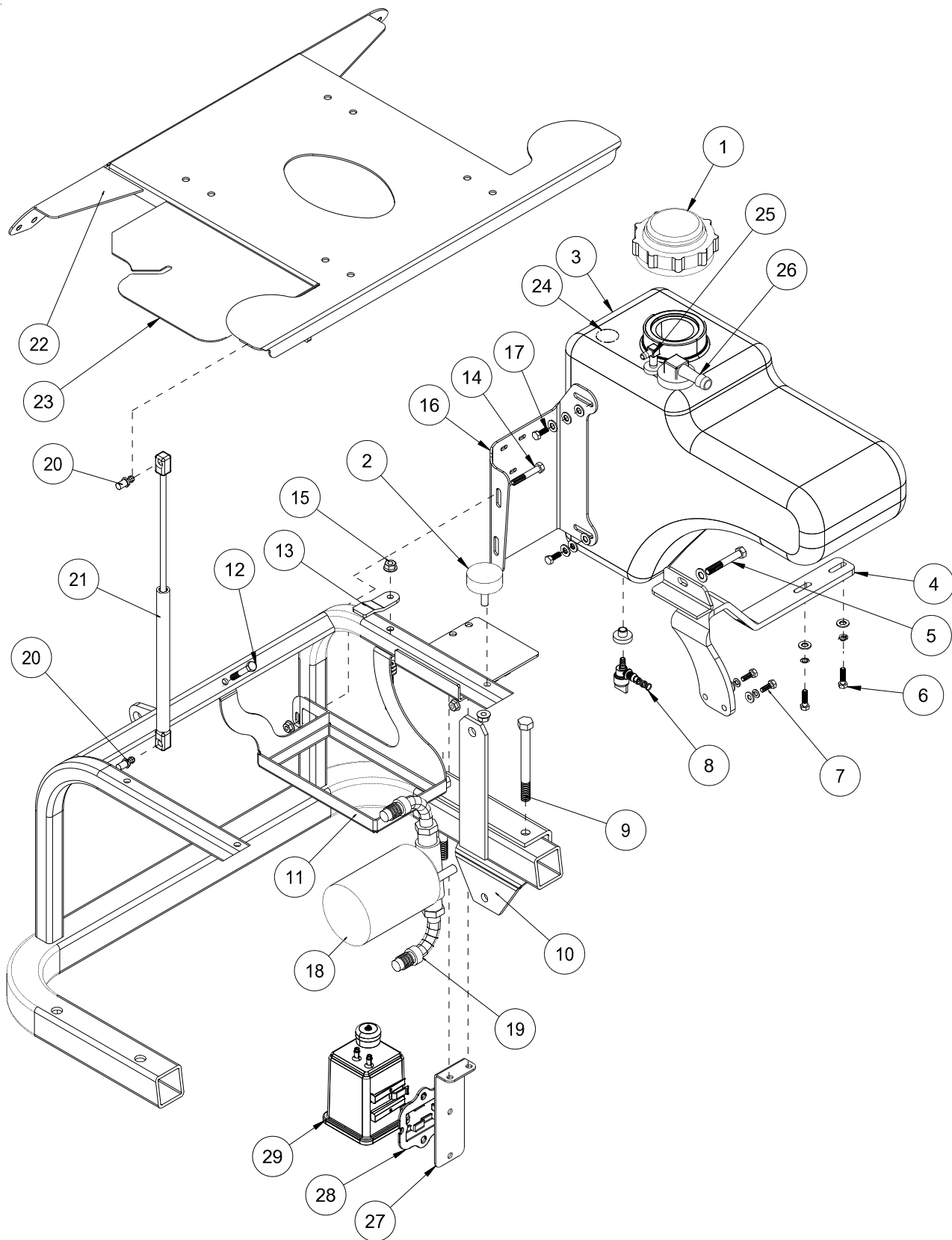

Parts

GAS TANK PARTSLIST

REF#	PART#	DESCRIPTION	QUANTITY
1*	42-814-02	Cap	1
*	42-814-01	Tether	1
2	50-081	Rubber Bumper	1
	HNFL-38-16	Flange Whiz Lock Nut $\frac{3}{8}$ - 16	1
3*	42-814	Gas Tank (includes all * items)	1
4	42-770	Right Tank Support	1
5	HB-38-16-200	Bolt $\frac{3}{8}$ - 16 x 2	1
	HW-38	Washer $\frac{3}{8}$	2
	HNFL-38-16	Flange Whiz Lock Nut $\frac{3}{8}$ - 16	1
6	HB-14-20-100	Bolt $\frac{1}{4}$ - 20 x 1	2
	HW-14	Washer $\frac{1}{4}$	2
	HW-516	Washer $\frac{5}{16}$	2
	HWL-14	Lock Washer $\frac{1}{4}$	2
7	HB-14-20-075	Bolt $\frac{1}{4}$ - 20 x $\frac{3}{4}$	2
	HWL-14	Lockwasher $\frac{1}{4}$	2
	HW-14	Washer $\frac{1}{4}$	2
8*	26-055	Fuel Tank Drain	1
*	26-054	Rubber Grommet	1
	8800-45	Fuel Hose	1
	18-186	Hose Clamp	2
9	HB-12-13-500	Bolt $\frac{1}{2}$ - 13 x 5	2
	HNFL-12-13	Flange Whiz Lock Nut $\frac{1}{2}$ - 13	2
10	42-015	Attachment Mount	1
11	42-273	Battery Box	1
12	HB-516-18-200	Bolt $\frac{5}{16}$ - 18 x 1	1
	HNFL-516-18	Flange Whiz Lock Nut $\frac{5}{16}$ - 18	1
13	42-248	Battery Hold-down	1
	15-020	Grip	1
14	HB-516-18-225	Bolt $\frac{5}{16}$ - 18 x $2\frac{1}{4}$	2
	HNFL-516-18	Flange Whiz Lock Nut $\frac{5}{16}$ - 18	2
15	HB-516-18-225	Bolt $\frac{5}{16}$ - 18 x $2\frac{1}{4}$	1
	HW-516	Washer $\frac{5}{16}$	3
	HNFL-516-18	Flange Whiz Lock Nut $\frac{5}{16}$ - 18	1
16	42-773	Gas Tank Bracket	1
17	HB-14-20-075	Bolt $\frac{1}{4}$ - 20 x $\frac{3}{4}$	2
	HW-14	Washer $\frac{1}{4}$	2
	HWL-14	Lock Washer $\frac{1}{4}$	2
18	23-006	Oil Filter	1
	23-031	Replacement Filter	1
19	34-123	Elbow	2
20	26-034	Ball Stud	2
21	13-569	Gas Shock	1
22	42-772	Seat Panel	1
23	43-157	Wire Cover	1
	HB-14-20-075	Bolt $\frac{1}{4}$ - 20 x $\frac{3}{4}$	2
	HNFL-14-20	Flange Nut $\frac{1}{4}$ - 20	2
24*	42-814-03	Fuel Level Gauge	1
25*	42-814-04	Top Draw	1
	8800-45	Fuel hose (goes to fuel pump on engine)	1
26*	42-814-05	Vent Check Valve	1
	8800-20	Hose (goes to carb canister)	1
27	42--815	Carb Canister Mount Bracket	1
28	8-688	Carb Canister Clip Mount	1
29	8-689	Carb Canister	1
	8-693	Hose Connector	1

OIL TANK DRAWING

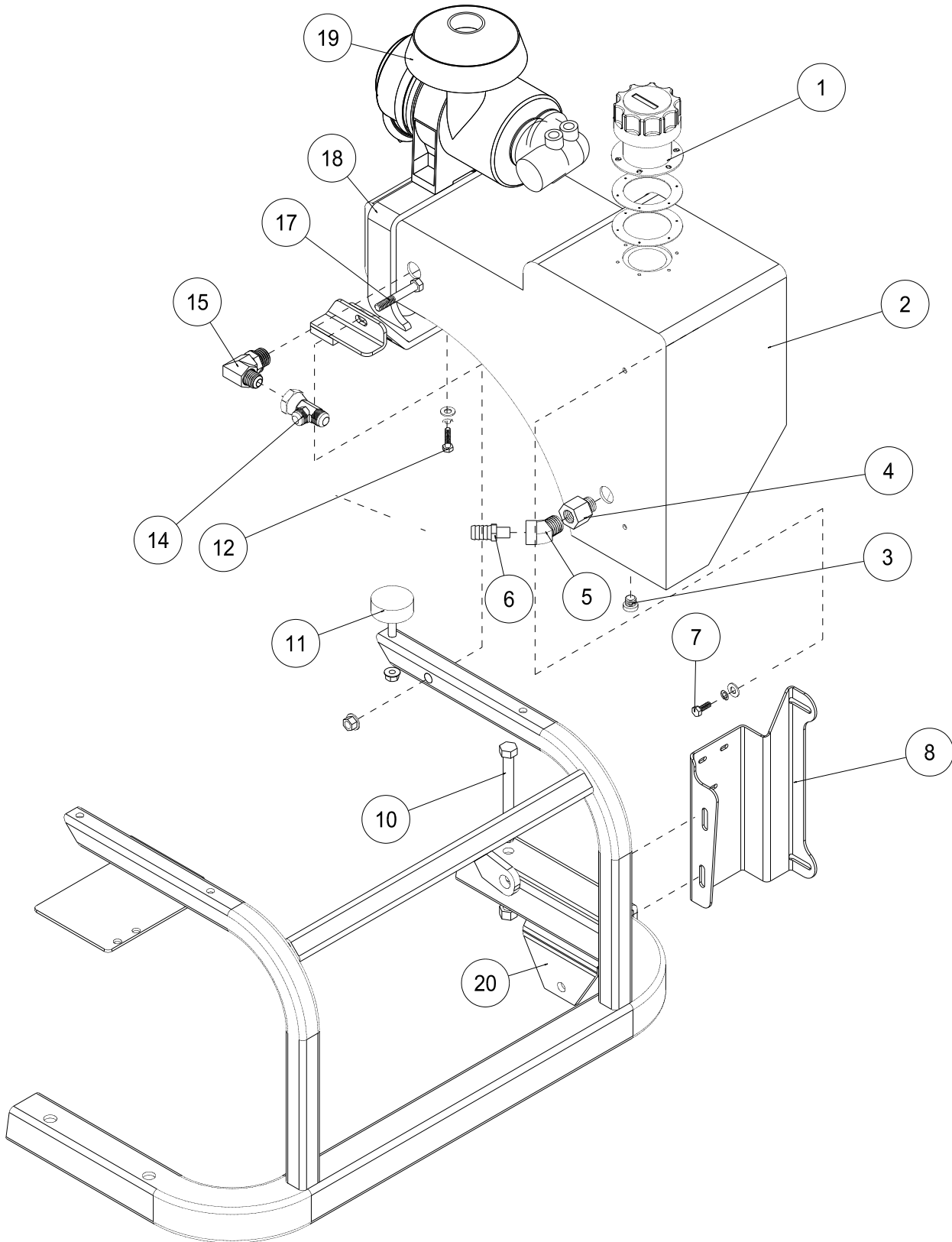

Parts

OIL TANK PARTSLIST

REF#	PART#	DESCRIPTION	QUANTITY
1	13-747	Filler Breather	1
	13-586-03	Neck	1
	HSM-8-32-063	Machine Screw #8 - 32 x 5/8	6
	HWS-8	Star Washer #8	6
2	42-005	Oil Tank	1
3	23-126	#6 Plug	1
4	18-240	Adapter	1
5	18-072	45° Elbow	1
6	18-133	Barb Fitting	1
7	HB-14-20-075	Bolt 1/4 - 20 x 3/4	2
	HW-14	Washer 1/4	2
	HWL-14	Lock Washer 1/4	2
8	42-774	Oil Tank Bracket	1
	HB-516-18-225	Bolt 5/16 - 18 x 2 1/4	2
	HNFL-516-18	Flange Whiz Lock Nut 5/16 - 18	2
10	HB-12-13-500	Bolt 1/2 - 13 x 5	2
	HNTL-12-13	Top Lock Nut 1/2 - 13	2
11	50-081	Rubber Bumper	1
	HNFL-38-16	Flange Whiz Lock Nut 3/8 - 16	1
12	HB-14-20-100	Bolt 1/4 - 20 x 1	2
	HW-516	Washer 5/16	2
	HW-14	Washer 1/4	2
	HWL-14	Lock Washer 1/4	2
14	18-337	Tee	1
15	23-189	90° Elbow	1
17	HB-38-16-250	Bolt 3/8 - 16 x 2 1/2	1
	HW-38	Washer 3/8	1
	HNFL-38-16	Flange Whiz Lock Nut 3/8 - 16	1
18	42-769	Left Tank Bracket	1
19	42-076	Remote Air Cleaner	1
20	42-015	Attachment Mount	2

PUMP AND ENGINE DRAWING

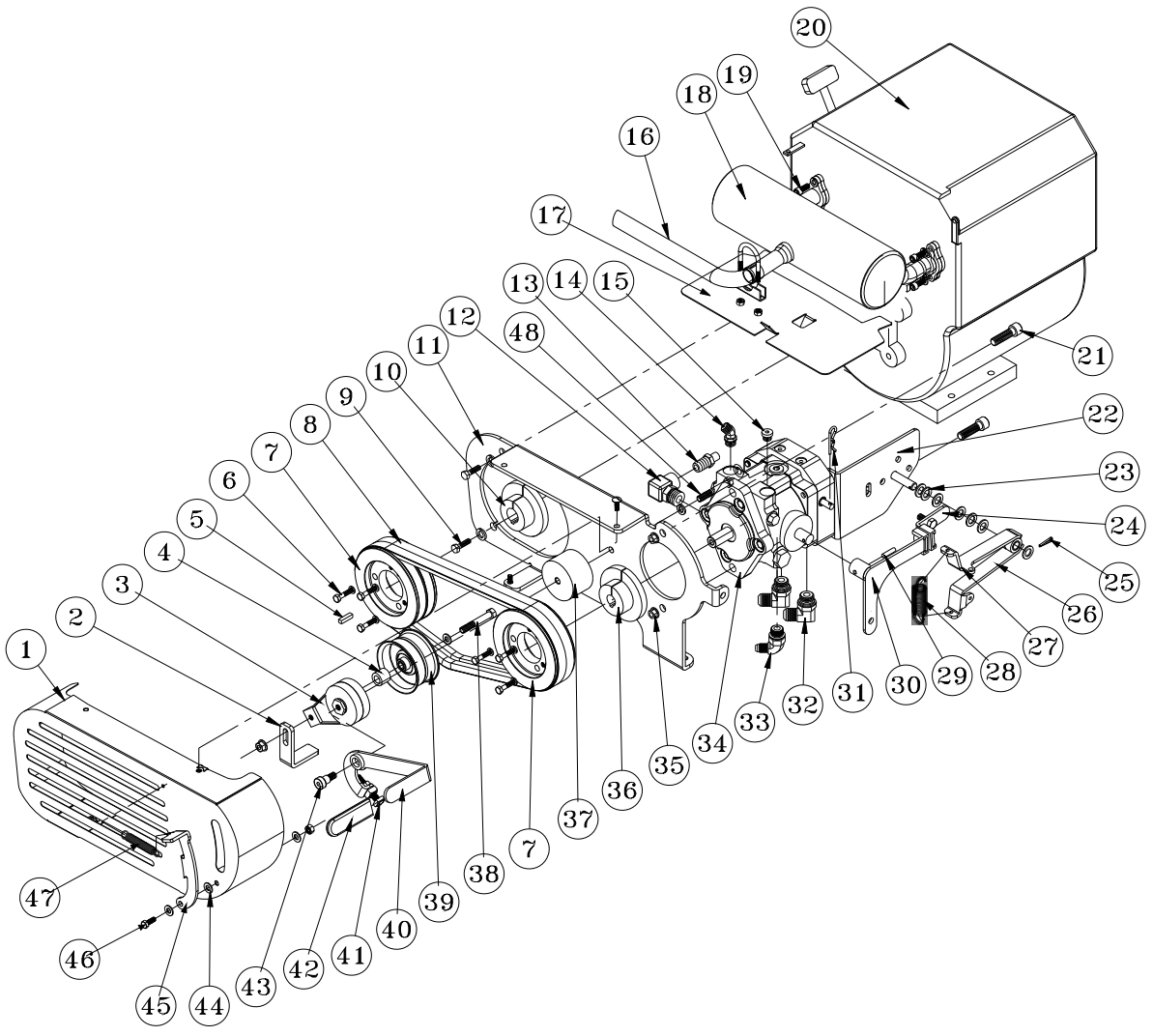

Parts

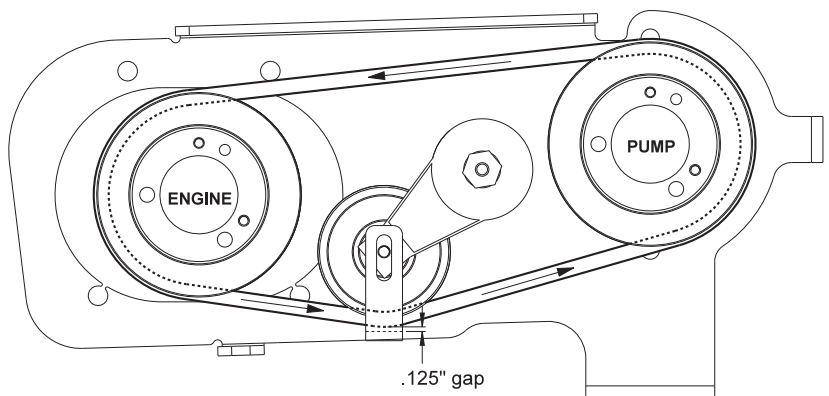

Belt Routing

PUMP AND ENGINE PARTS LIST

REF#	PART#	DESCRIPTION	QUANTITY
1	42-353	Belt Guard	1
	78-274	Cage Nut	2
	HB-14-20-075	Hex Bolt, $\frac{1}{4}$ - 20 x $\frac{3}{4}$	2
	HWL-14	Lock Washer, $\frac{1}{4}$	2
2	42-357	Belt Stop	1
3	42-327	Tensioner	1
4	16-990	Spacer	1
5	HKSQ-14-100	Machine Key $\frac{1}{4}$ x $\frac{1}{4}$ x 1	1
6	HB-14-20-125	Bolt $\frac{1}{4}$ - 20 x $1\frac{1}{4}$ (comes with 42-245 & 42-246)	6 (3 per hub)
	HW-14	Lockwasher (comes with 42-245 & 42-246)	6 (3 per hub)
7	42-331	Pulley	2
8	42-359	Belt	2
9	HB-716-14-100	Bolt $\frac{7}{16}$ - 14 x 1	4
	HWL-716	Lockwasher $\frac{7}{16}$	4
10	42-245	Hub 1"	1
11	42-354	Pump Mount	1
12	23-130	Elbow 90°	1
13	18-133	Barb Fitting	1
14	18-188	Elbow 45°	1
15	23-126	Plug	1
16	13-493	Tailpipe	1
	13-498	Muffler Clamp	1
17	42-306	Heat Shield	1
	18-222	Hose Clamp	2
18	27-123	Muffler	1
19	HSSHSM-8-1.25-20	Metric Cap Screw M8 - 1.25 x 20	4
	HWLM-8	Lockwasher M8	4
20	15-165	Engine B&S 16 HP	1
	15-165-01	Air Filter Element with Pre-Cleaner (comes with engine)	1
	13-531	Engine Oil Filter (comes with engine)	1
	13-491	Oil Switch (comes with engine)	1
	13-748	Solenoid	1
	13-749	Push on Connector	1
21	HSSHHS-12-13-175	Socket Screw $\frac{1}{2}$ - 13 x $1\frac{3}{4}$	2
22	42-279	Filter Mount	1
	HW-38	Washer $\frac{3}{8}$	2
23	HMB-12-14	Machine Bushing $\frac{1}{2}$ x 14 GA	7
24	42-247	Creep Arm	1
	8946-1.5	Wear Strip (part of 42-247)	1
	HRS-316-050	Rivet (part of 42-247)	1
	HB-38-16-100	Bolt $\frac{3}{8}$ - 16 x 1	2
	HNFL-38-16	Flange Whiz Lock Nut $\frac{3}{8}$ - 16	2
25	HP-18-100	Cotter Pin $\frac{1}{8}$ x 1	1
26	42-312	Bottom Centering Arm	1
	18-234	Bushing (part of 42-312)	1
27	42-311	Top Centering Arm	1
	18-234	Bushing (part of 42-311)	1
28	11-050	Extension Spring	1
29	HRP-14-100	Roll Pin $\frac{1}{4}$ x 1	1
30	42-308	Swash Arm	1
	8946-1	Wear Strip (part of 42-308)	1
	HRS-316-050	Rivet (part of 42-308)	1

(Continued on next page)



PUMP AND ENGINE DRAWING

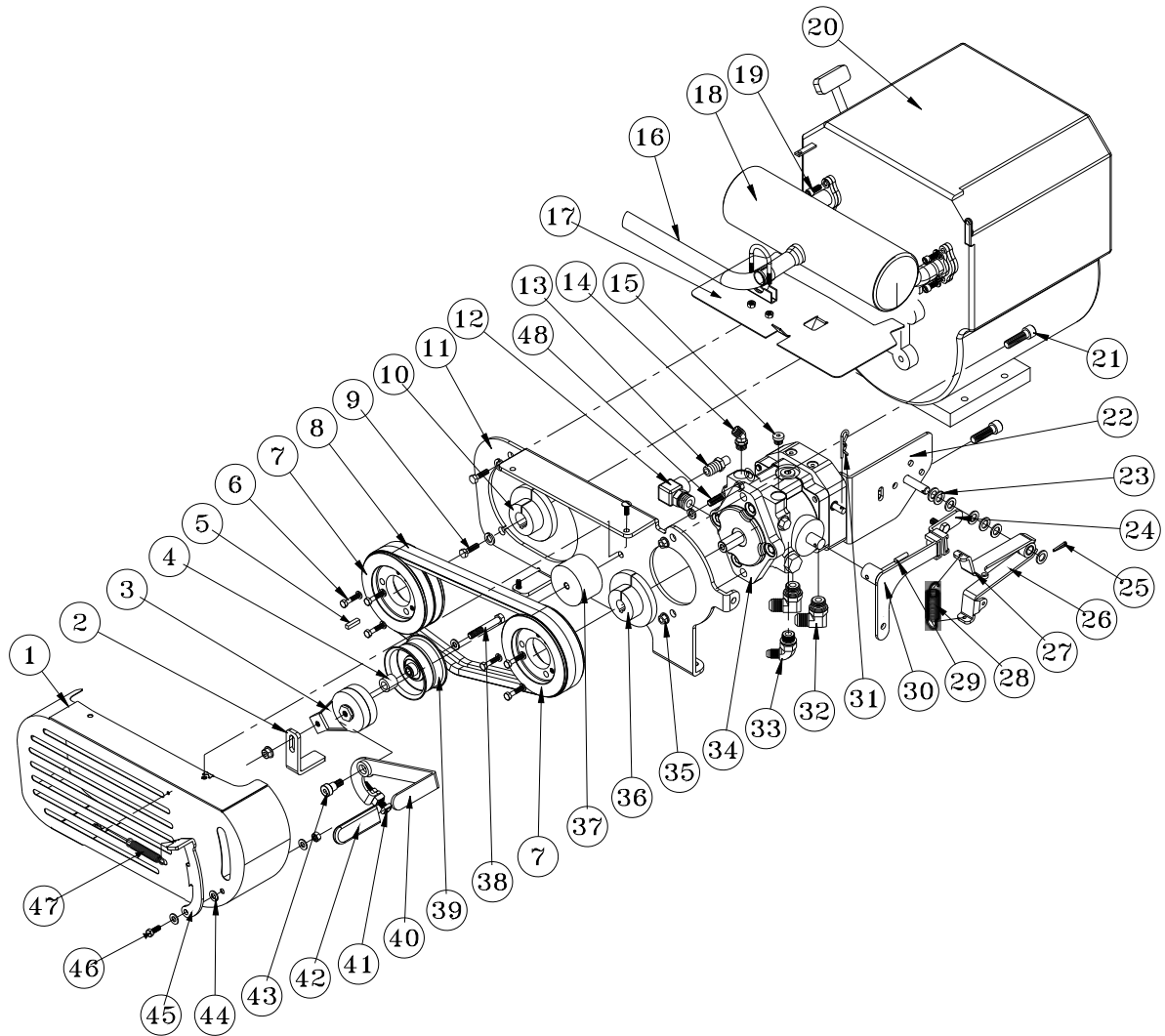

Parts

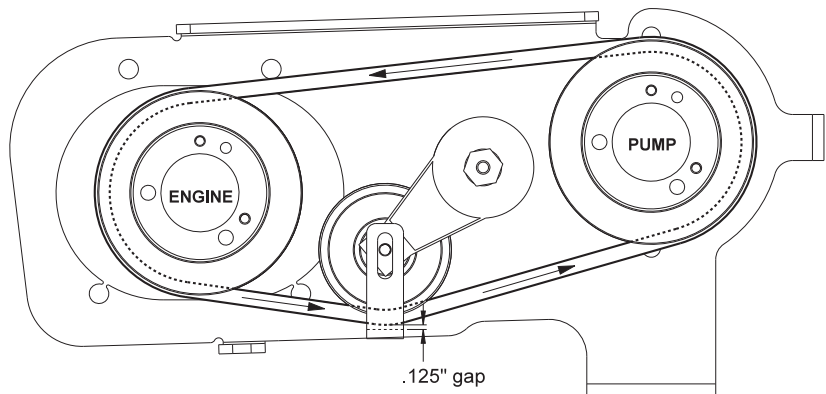

Belt Routing

PUMP AND ENGINE PARTS LIST

REF#	PART#	DESCRIPTION	QUANTITY
31	HHP-18	Bridge Pin $\frac{1}{8}$	1
32	18-174	Elbow 90°	2
33	18-185	Elbow	1
34	42-5 99	Variable Pump (3WD)	1
35	HNTL-12-13	Lock Nut $\frac{1}{2}$ - 13	2
36	42-246	Hub $\frac{3}{4}$	1
	HWK-316-075	Woodruff Key	1
37	42-361	Tensioner Spacer	1
38	HB-38-16-275	Hex Bolt, $\frac{3}{8}$ -16 x $2\frac{3}{4}$	1
	HNFL-38-16	Flange Whiz Lock Nut, $\frac{3}{8}$ -16	1
	HW-38	Flat Washer, $\frac{3}{8}$	1
39	42-358	Idler Pulley	1
	42-338	Oilite Bushing	1
40	42-355	Clutch Handle	1
41	HSSQ-38-16-200	Socket Head Square Screw $\frac{3}{8}$ - 16 x 2	1
	HN-38-16	Hex Nut, $\frac{3}{8}$ - 16	1
42	15-020	Grip	1
43	42-352	Hex Socket Head shoulder Screw	1
44	HW-38	Flat Washer, $\frac{3}{8}$	3
45	42-356	Lock Handle	1
46	HB-516-18-075	Hex Bolt, $\frac{5}{16}$ -18 x $\frac{3}{4}$	1
	HNTL-516-18	Lock Nut, $\frac{5}{16}$ -18	1
47	16-046	Spring	1
48	HB-38-16-250	Hex Bolt, $\frac{3}{8}$ -16 x $2\frac{1}{2}$	1
	HWL-38	Lock Washer, $\frac{3}{8}$	1

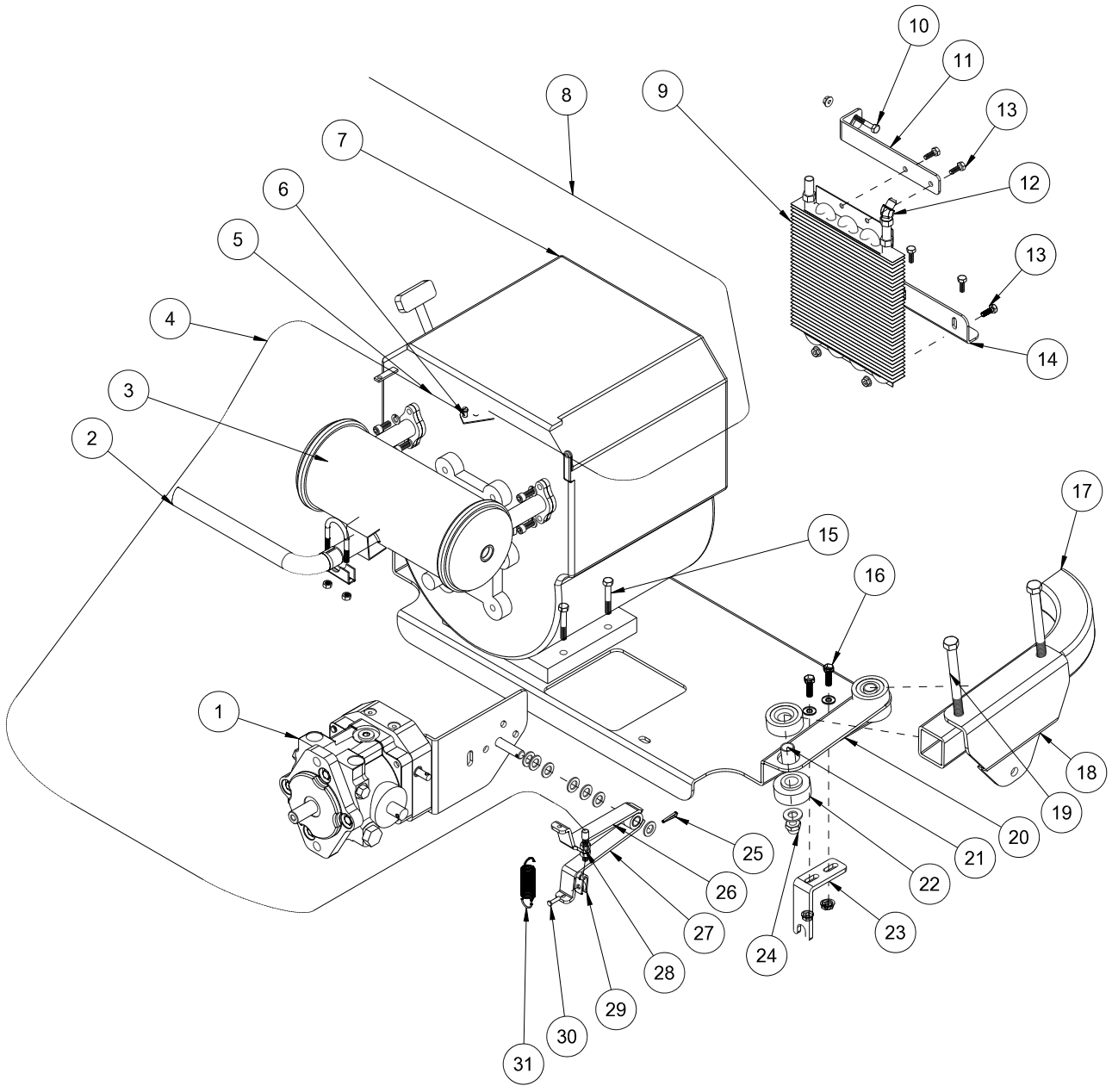

REF #	PART #	DESCRIPTION	QUANTITY
1	42-599	Variable Pump	1
2	13-493	Tailpipe	1
	13-498	Muffler Clamp	1
3	27-123	Muffler	1
4*	17-152	Conduit	1
5*	17-151	Cable	1
6	21-161	Wire Block	4
7	15-165	Engine B&S 16 hp	1
8	42-789	Throttle (hand)	1
9	42-265	Aluminum Oil Cooler	1
10	HB-14-20-150	Bolt $\frac{1}{4}$ - 20 x $1\frac{1}{2}$	1
	HNFL-14-20	Flange Whiz Lock Nut $\frac{1}{4}$ -20	1
11	42-771	Top Cooler Bracket	1
12	18-214	Elbow 45°	1
13	HB-14-20-075	Bolt $\frac{1}{4}$ - 20 x $\frac{3}{4}$	4
	HNFL-14-20	Flange Whiz Lock Nut $\frac{1}{4}$ - 20	4
14	42-275	Bottom Cooler Bracket	1
15	HB-516-18-225	Bolt $\frac{5}{16}$ - 18 x $2\frac{1}{4}$	4
	HNFL-516-18	Flange Whiz Lock Nut $\frac{5}{16}$ - 18	4
16	HB-516-18-100	Bolt $\frac{5}{16}$ - 18 x 1	2
	HW-516	Washer $\frac{5}{16}$	2
	HNTL-516-18	Lock Nut $\frac{5}{16}$ - 18	2
17		Main Frame	
18	42-015	Attachment Mount	2
19	HB-12-13-500	Bolt $\frac{1}{2}$ -13 x 5	4
20	42-269	Engine Plate	1
21	60-168	Spacer	4
22	60-107	Rubber Bushing	8
23	42-307	Cable Bracket	1
24	HNTL-12-13	Lock Nut $\frac{1}{2}$ - 13	4
	HW-12	Washer $\frac{1}{2}$	4
25	HP-18-100	Cotter Pin $\frac{1}{8}$ x 1	1
	HMB-12-14	Machine Bushing $\frac{1}{2}$ x 14 GA	7
26	42-311	Top Centering Arm	1
	18-234	Bushing (part of 42-311)	1
27	42-312	Bottom Centering Arm	1
	18-234	Bushing (part of 42-312)	1
28*	17-155	Retainer	1
	HN-516-24	Nut $\frac{5}{16}$ - 24	2
29*	17-153	Clevis	1
30	HCP-14-075	Clevis Pin $\frac{1}{4}$ x $\frac{3}{4}$	1
	HP-332-075	Cotter Pin $\frac{3}{32}$ x $\frac{3}{4}$	1
31	11-050	Extension Spring	1

* must order all parts for complete assembly

REAR AXLE DRAWING

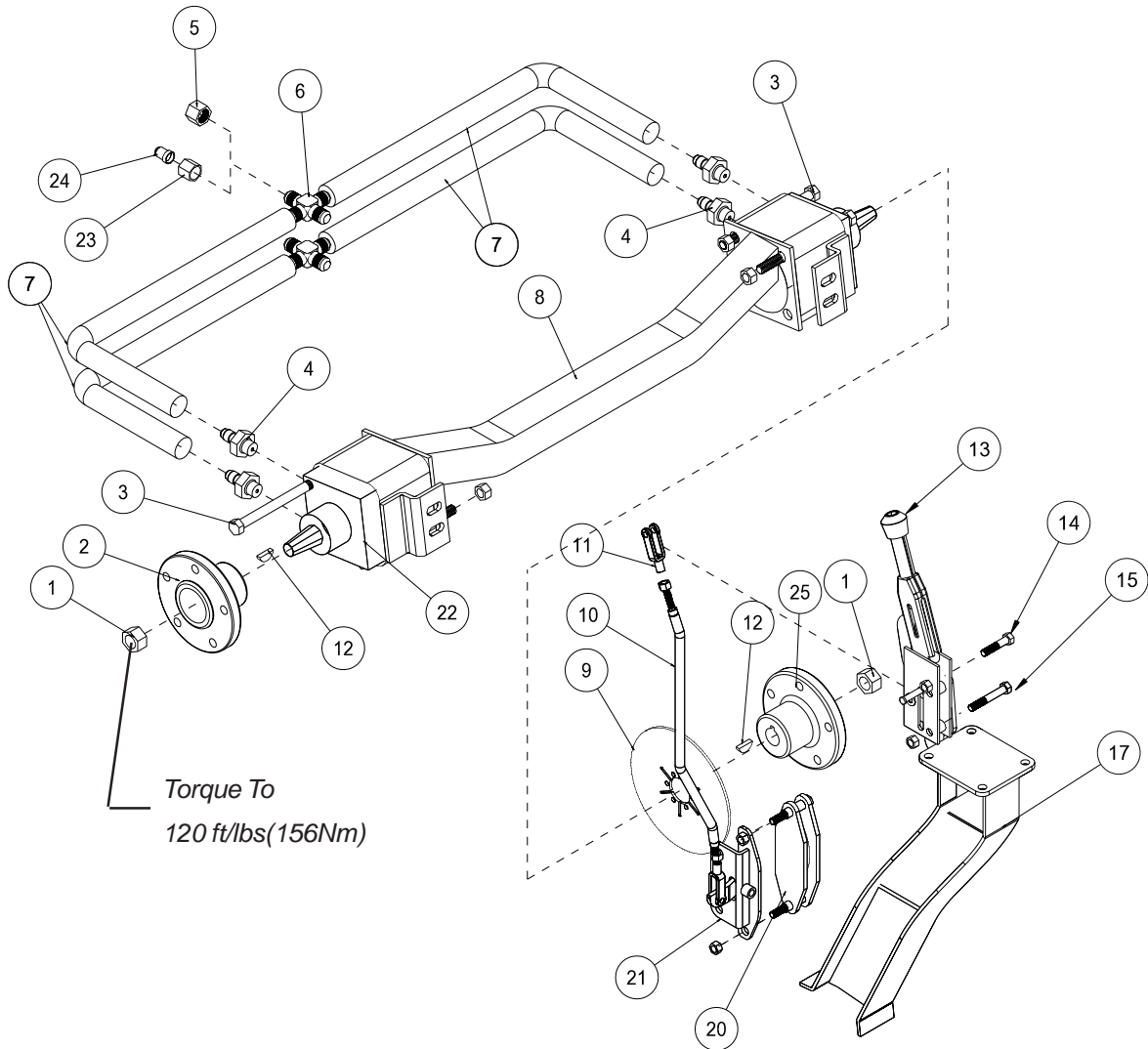

Parts

REAR AXLE PARTSLIST

REF#	PART#	DESCRIPTION	QUANTITY
1	42-002-12	Nut $\frac{3}{4}$ - 16 (part of 42-002)	2
2	42-007	Hub	1
3	HB-12-13-700	Bolt $\frac{1}{2}$ - 13 x 7	8
	HNTL-12-13	Top Lock Nut $\frac{1}{2}$ - 13	8
4	18-343	Adapters	4
5	18-344	Caps (2WD ONLY)	2
6	18-342	Cross	2
7	42-818	$\frac{1}{2}$ " Hydraulic Hose	4
8	42-605	Main Frame	1
9	50-041	Brake Disk	1
	42-176	Low Head Cap Screw $\frac{1}{4}$ - 20 x $\frac{3}{4}$	6
10	42-804	Brake Rod	1
	HN-516-24	Nut $\frac{5}{16}$ - 24	2
11	11-100	Linkage Yoke	2
	HCP-516-100	Clevis Pin $\frac{5}{16}$ x 1	2
	HP-18-100	Cotter Pin $\frac{1}{8}$ x 1	2
12	HWK-14-100	Woodruff Key $\frac{1}{4}$ x 1 (part of 42-002)	2
13	60-106	Brake Lever	1
14	HB-516-18-175	Bolt $\frac{5}{16}$ - 18 x $1\frac{3}{4}$	1
	HNFL-516-18	Flange Whiz Lock Nut $\frac{5}{16}$ - 18	1
15	HB-516-18-250	Bolt $\frac{5}{16}$ - 18 x $2\frac{1}{2}$	1
	HNFL-516-18	Flange Whiz Lock Nut $\frac{5}{16}$ - 18	1
17		Main Frame	1
20	50-042	Brake Caliper	1
	60-563	Disc Pad, Outside	1
	60-564	Disc Pad, Inside	1
21	42-151	Brake Bracket	1
22	42-002	Wheel Motor	2
23	23-120	$\frac{1}{2}$ " Tube Nut (3WD only)	2
24	34-128	Reducer (3WD only)	2
25	42-157	Right-hand Hub	1
	42-305	Shim	1
	34-101-01	Brake Pads (only)	
	34-101-02	Brake Pad Kit (pads with steel backing plate)	

RAKE LIFT DRAWING

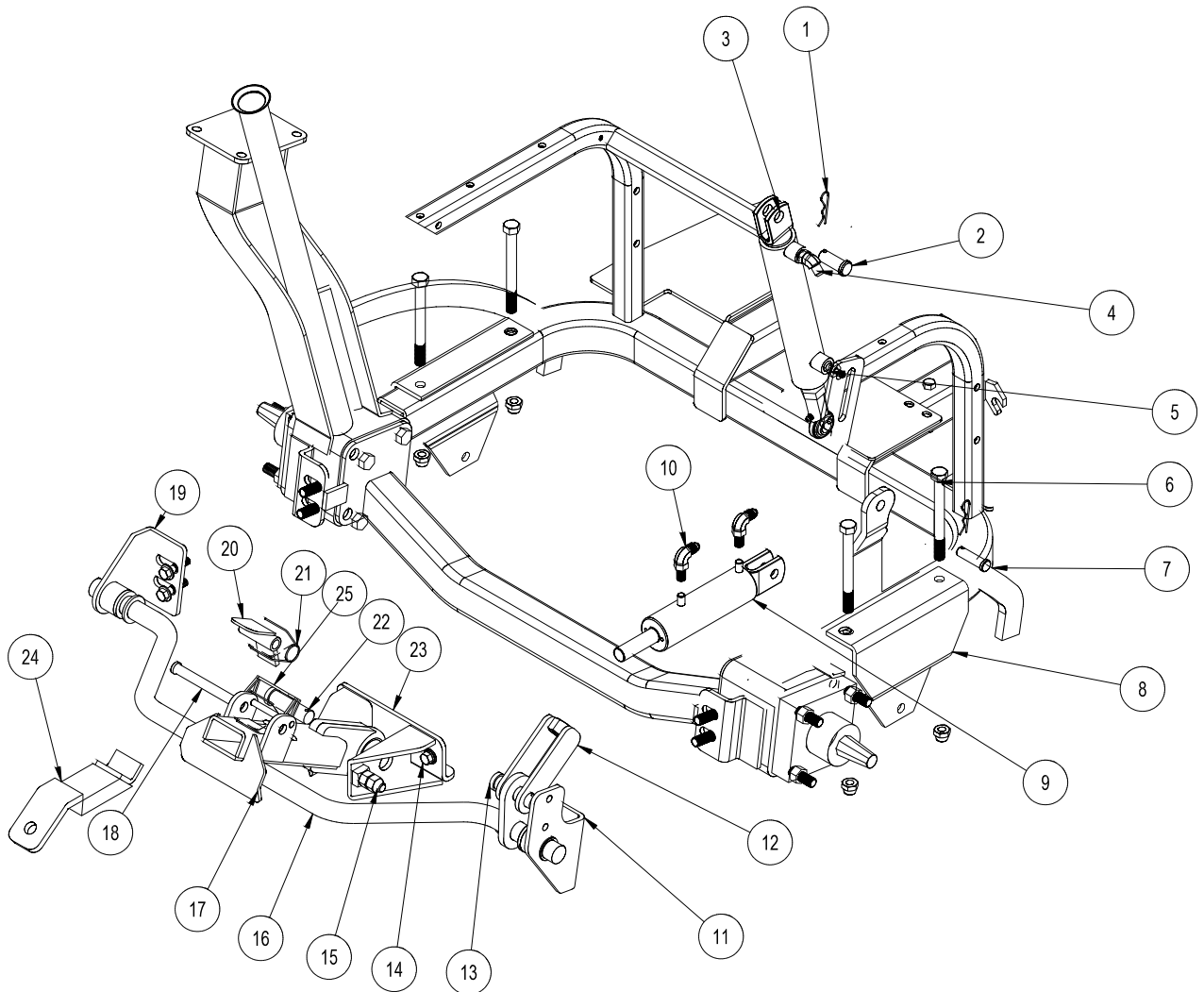

Parts

RAKE LIFT PARTS LIST

REF#	PART#	DESCRIPTION	QUANTITY
1	HHP-18	Bridge Pin $\frac{1}{8}$	3
2	HCP-58-175	Clevis Pin $\frac{5}{8}$ - $1\frac{3}{4}$	1
3	10-554	Hydraulic Cylinder	1
	HNJ-58-18	Jam Nut $\frac{5}{8}$ - 18	1
	8-154	Rod End	1
	HG-14-28-180	Grease Fitting $\frac{1}{4}$ - 28 x 180°	1
4	18-214	45° Elbow	1
5	18-169	$\frac{3}{8}$ Adapter	1
6	HB-12-13-500	Bolt $\frac{1}{2}$ - 13 x 5	4
	HNFL-12-13	Flange Lock Nut $\frac{1}{2}$ - 13	4
7	HCP-12-300	Clevis Pin $\frac{1}{2}$ - 3	1
	HP-18-100	Cotter Pin $\frac{1}{8}$ x 1	1
8	42-015	Attachment Mount	2
9	43-150	Hydraulic Cylinder	1
10	18-168	90° Elbow	2
11	34-220	Pivot Bracket - RH	1
	33-086	Flange Bushing	1
12	43-138	Lift Linkage	1
13	HCP-34-200	Clevis Pin $\frac{3}{4}$ x 2	1
14	HB-38-24-100	Bolt $\frac{3}{8}$ - 24 x 1	2
15	HSSHB-12-13-200	Button Socket Head Cap Screw	2
	HN-12-13	Nut $\frac{1}{2}$ -13	2
	HNCL-12-13	Center Lock Nut $\frac{1}{2}$ - 13	2
16	43-137	Lift Bar	1
	15-019	Rubber Grip	2
17	43-141	Lift Arm	1
18	HCP-12-450	Clevis Pin $\frac{1}{2}$ - $4\frac{1}{2}$	1
19	34-219	Pivot Bracket - LH	1
	33-086	Flange Bushing	1
20	43-139	Lock	1
21	43-136	Torsion Spring	1
22	HCP-78-350	Clevis Pin $\frac{7}{8}$ x $3\frac{1}{2}$	1
23	43-140	Frame Mount	1
24	43-143	Towing Hitch	1
25	25-382	Lock Pin	1

13-729 2-BANK HYDRAULIC VALVE DRAWING

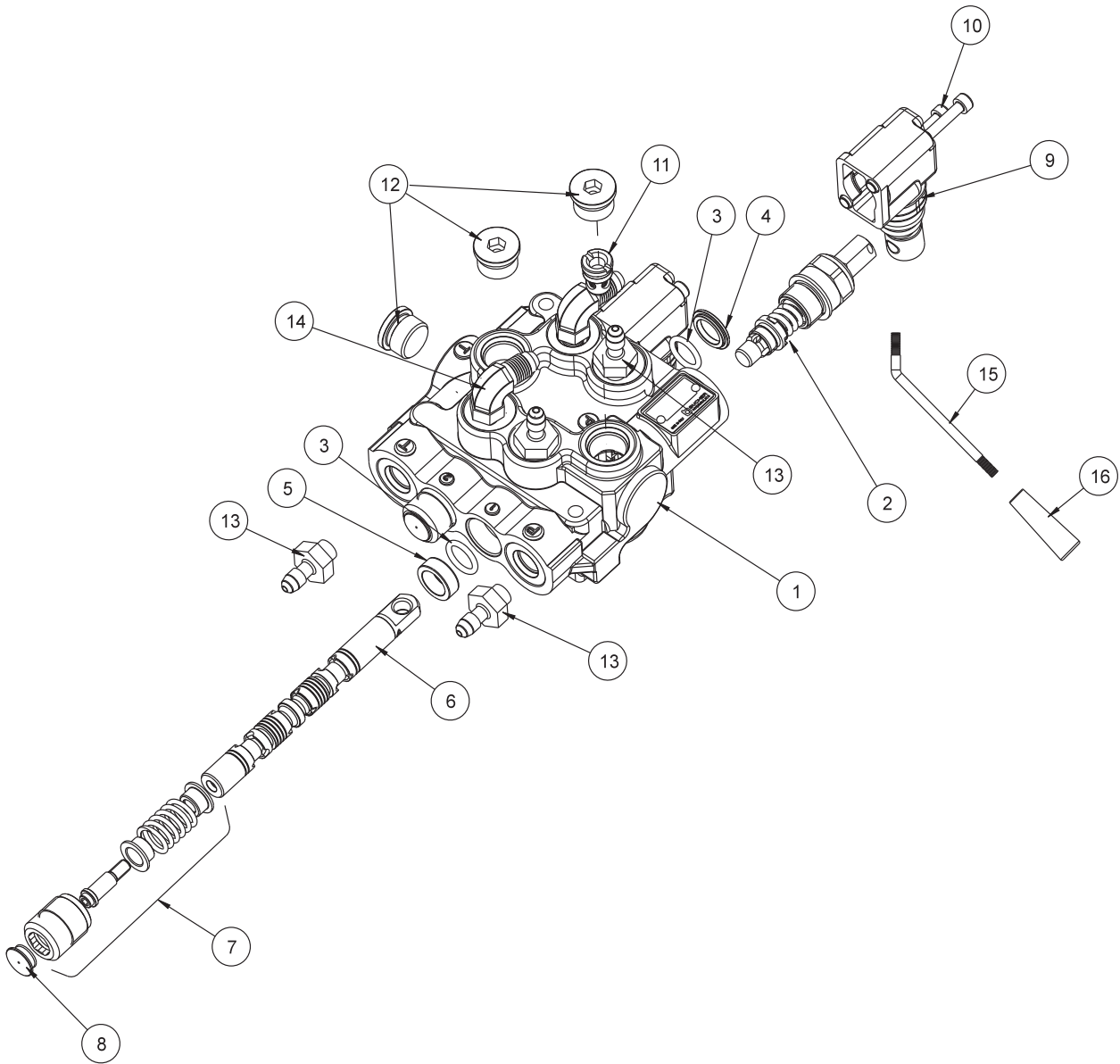

Parts

13-729 2-BANK HYDRAULIC VALVE PARTSLIST

REF #	PART #	DESCRIPTION	QUANTITY
1*	78-415-01	Body (complete with spacer and check valve)	1
2*	78-415-02	Spool HDM10	1
3*	78-415-03	O-Ring Seal	6
4*	78-415-04	Flanged Washer HDM10	3
5*	78-415-05	Spacer	3
6*	78-415-06	A Type Spool HDS11	3
7*	78-415-11	Positioner	2
8*	78-415-08	Plug	3
9*	78-415-09	Lever Group HDS11	3
10*	78-415-10	Metric Socket Screw M5 x .8 x 45	6
11*	78-415-12	Check Valve Assembly HDM12	1
12*	78-415-13	³ / ₄ - 16 SAE 8 Screw Plug	3
13	18-166	Adapter ¹ / ₄ - ³ / ₈ SAE	4
14	18-168	Elbow 3/8 Straight Thread	2
15	78-418	Bent Handle	2
16		Tapered Knob	3
* 13-729		2 – Bank Hydraulic Valve (includes all * items)	

42-039 FRONT WHEEL MOTOR (4.0 C.I.) DRAWING

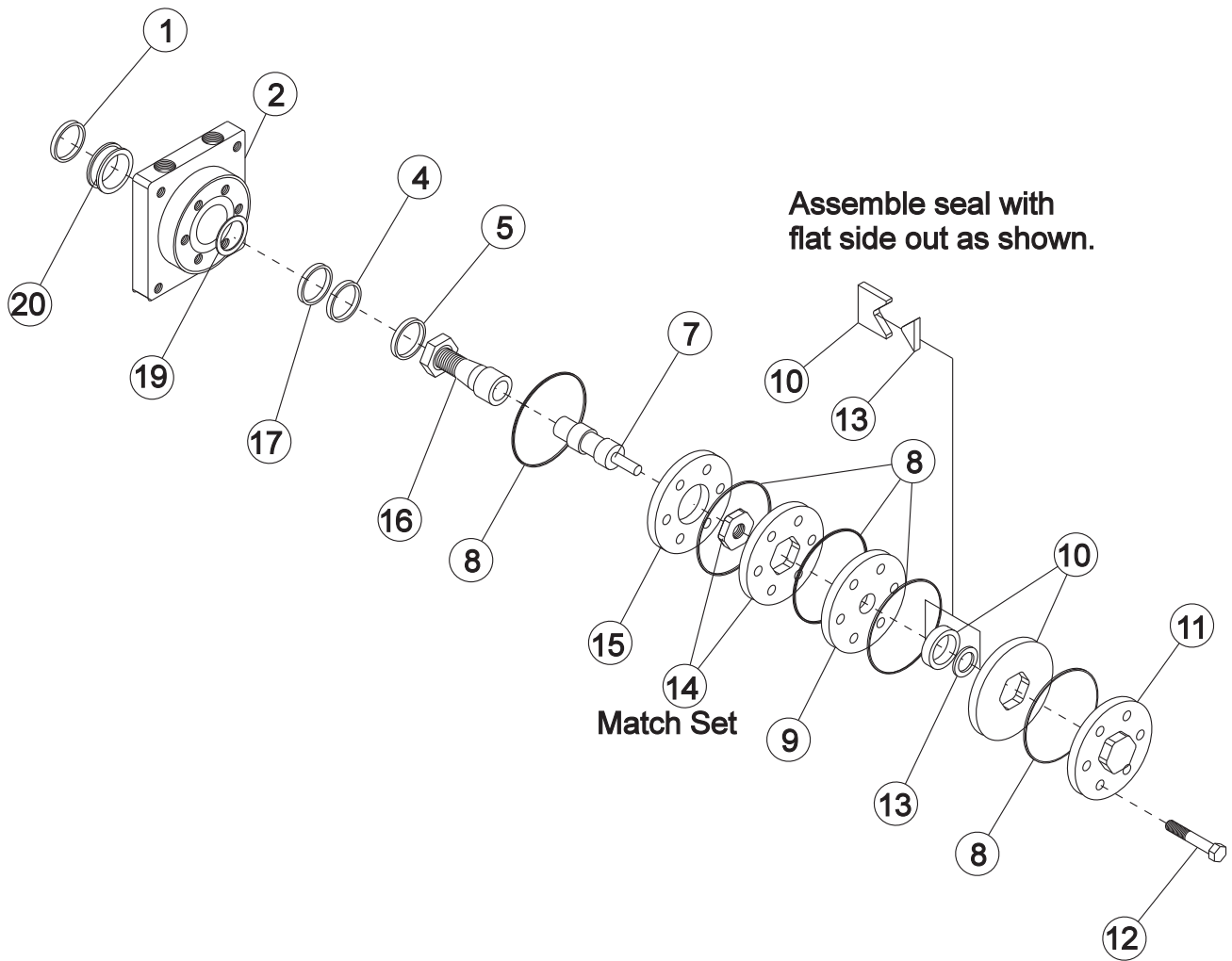

Parts

42-039 FRONT WHEEL MOTOR (4.0 C.I.) PARTSLIST

REF #	PART #	DESCRIPTION	QUANTITY
1*		Water & Dirt Seal	1
2	42-002-01	Service Housing Assembly	1
4	42-002-02	Thrust Bearing	1
5	42-002-03	Inner Bearing	1
7	42-039-01	Drive Link	1
8*		Ring Seal	5
9	42-002-05	Manifold	1
10	42-002-06	Commutator Assembly (matched set)	1
11	42-002-07	End Cap	1
12	42-039-02	Bolt	5
13*		Commutator Seal (matches with #10)	1
14	42-039-03	Rotor Set (matched set)	1
15	42-002-10	Wear Plate	1
16	42-002-11	Coupling Shaft	1
	HWK-14-100	Woodruff Key 1/4 x 1	1
	42-002-12	Nut 3/4 - 16	1
17	42-002-13	Thrust Washer	1
19*		Backup Ring	1
20	42-002-14	Outer Bearing	1
*	42-002-15	Seal Kit	1

42-002 REAR WHEEL MOTOR (8.0 C.I.) DRAWING

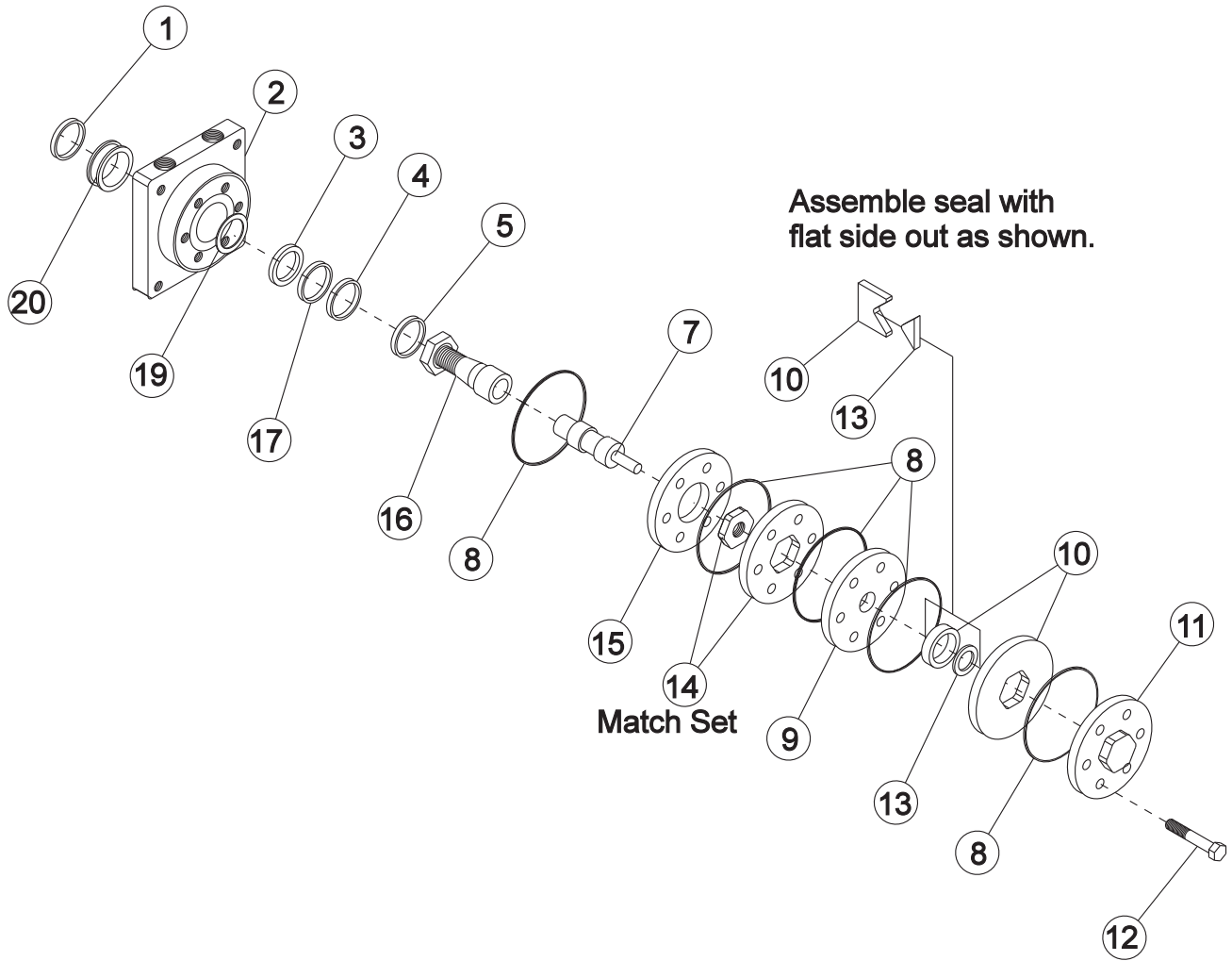

42-002 REAR WHEEL MOTOR (8.0 C.I.) PARTSLIST

REF #	PART #	DESCRIPTION	QUANTITY
1*		Water & Dirt Seal	1
2	42-002-01	Service Housing Assembly	1
4	42-002-02	Thrust Bearing	1
5	42-002-03	Inner Bearing	1
7	42-002-04	Drive Link	1
8*		Ring Seal	5
9	42-002-05	Manifold	1
10	42-002-06	Commutator Assembly (matched set)	1
11	42-002-07	End Cap	1
12	42-002-08	Bolt	5
13*		Commutator Seal (matches with #10)	1
14	42-002-09	Rotor Set (matched set)	1
15	42-002-10	Wear Plate	1
16	42-002-11	Coupling Shaft	1
	HWK-14-100	Woodruff Key 1/4 x 1	1
	42-002-12	Nut 3/4 - 16	1
17	42-002-13	Thrust Washer	1
19*		Backup Ring	1
20	42-002-14	Outer Bearing	1
*	42-002-15	Seal Kit	1

42-302 ELECTRIC ON - OFF VALVE DRAWING

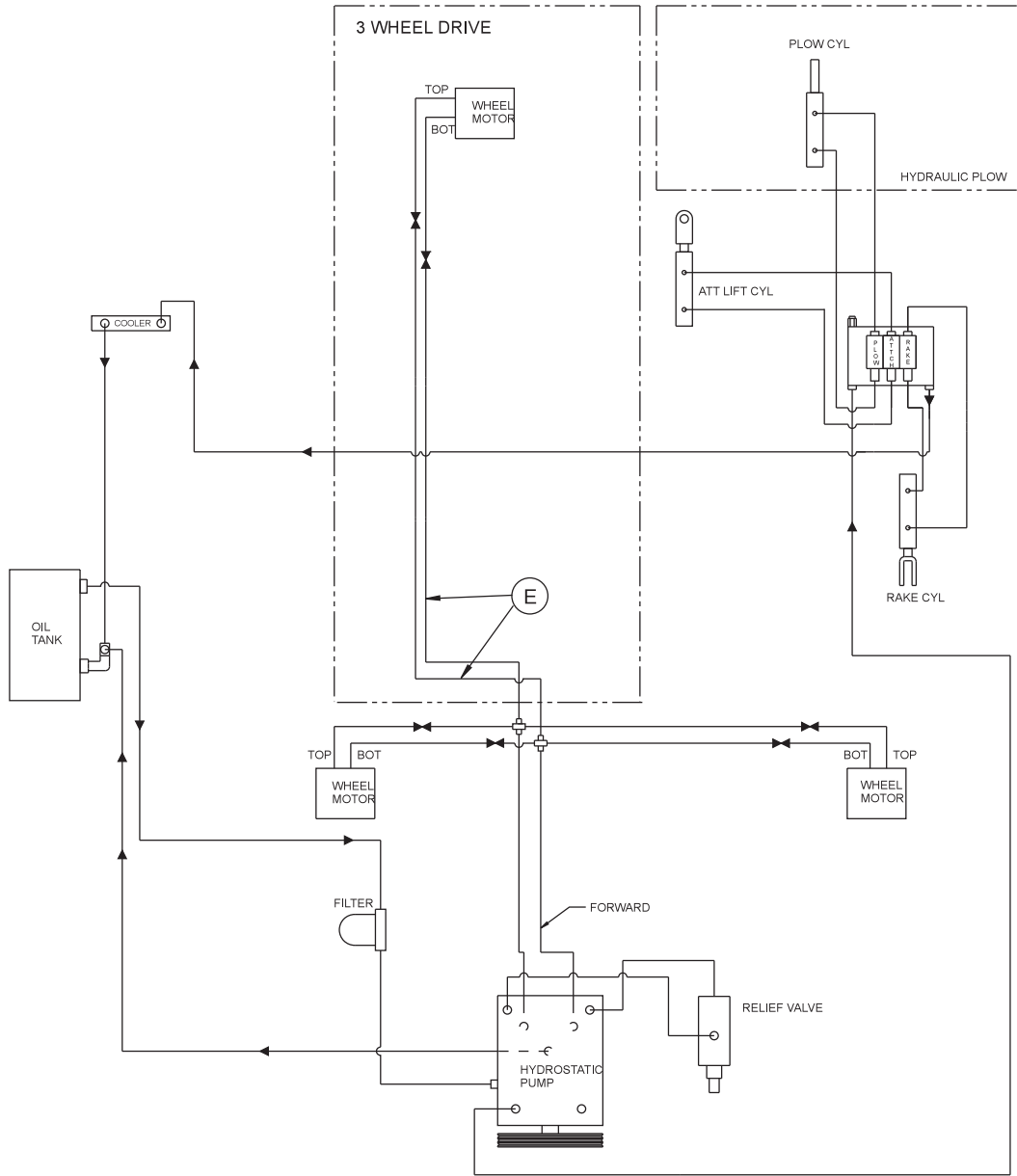
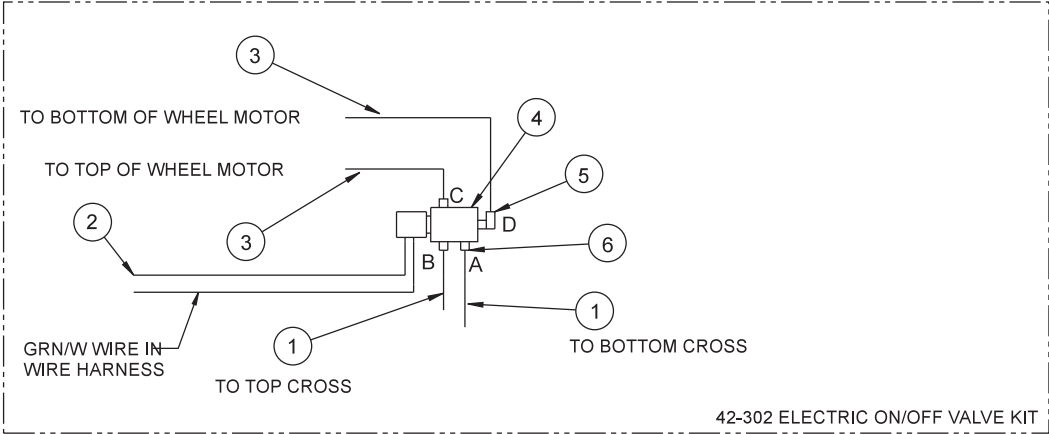

Parts

42-302 ELECTRIC ON - OFF VALVE PARTS LIST

REF #	PART #	DESCRIPTION	QUANTITY
1	42-263	Hydraulic Hose	2
2	76-260	Wire, Ground	1
3	42-264	Hydraulic Hose	2
4	42-118	Electric On/Off Valve	1
	HB-14-20-200	Bolt 1/4 - 20 x 2	2
	HNFL-14-20	Flange Whiz Lock Nut 1/4 - 20	2
5	18-185	Elbow 90°	1
6	18-341	Elbow 45°	3

INSTALLATION INSTRUCTIONS

1. Shut off machine and let engine cool. Remove key, disconnect negative (-) battery cable and pull spark plug wires..
2. Assemble the fittings into the electric on/off valve. With valve lying on bench with solenoid to the left, install the three 45° elbows (Ref 6) in the two ports closest to you and one port furthest from you. Install the one 90° elbow (Ref 5) in the right hand port.
3. Install two 42-264 hydraulic hoses (Ref 3) on C and D. Tighten.
4. Install two 42-263 hydraulic hoses (Ref 1) on A and B. Be sure straight end of hose is on the valve with the fitting going backward. Tighten.
5. Remove mud guard and place a drain pan under the cross fittings that the hoses from the front wheel motor go to.
6. Disconnect the two hoses going to the front wheel motor at the cross, then at the front wheel motor and remove.
7. Remove the cover plate from the fiber glass.
8. Feed two 42-264 hydraulic hoses (Ref 3) up through bearing plate, through the 3" hole, and out to the front fork. Connect to the front wheel motor with the hose from D to the bottom of the wheel motor and C to the top.
9. Bolt valve to bearing plate with solenoid to your left side. Use the 1/4 -20 x 2 bolt and flange whiz lock nut. Be sure to fasten the ground wire on one of the mounting bolts and the other end on one terminal of the solenoid valve.
10. Connect the two 42-263 hydraulic hoses (Ref 1) from the valve to the cross with the hose from A to the bottom cross and B to the top cross.
11. Install toggle switch on control panel. Uncoil green and white stripe wire from frame and hook on end to the toggle switch and the other end to the terminal on electric on/off valve. Install the loose end of the blue/white wire to the toggle switch.
12. Route hose and secure with 22-069 nylon ties. Reinstall mud guard.
13. Reconnect the negative (-) ground battery cable to battery and spark plug wires.
14. Make sure that everything is clear of the machine. Start the machine, test on/off valve for proper operation.
15. Check for hydraulic leaks.
16. Shut off machine, double check all fastener and fittings, be sure they are tight.
17. Reinstall cover plate.
18. Check hydraulic fluid, level should be 2 to 2 1/2 inches below the top of the tank when cold. Add if necessary.

42-302 ELECTRIC ON - OFF VALVE PARTS LIST

REF #	PART #	DESCRIPTION	QUANTITY
1	42-263	Hydraulic Hose	2
2	76-260	Wire, Ground	1
3	42-264	Hydraulic Hose	2
4	42-118	Electric On/Off Valve	1
	HB-14-20-200	Bolt 1/4 - 20 x 2	2
	HNFL-14-20	Flange Whiz Lock Nut 1/4 - 20	2
5	18-185	Elbow 90°	1
6	18-341	Elbow 45°	3

INSTALLATION INSTRUCTIONS

1. Shut off machine and let engine cool. Remove key, disconnect negative (-) battery cable and pull spark plug wires..
2. Assemble the fittings into the electric on/off valve. With valve lying on bench with solenoid to the left, install the three 45° elbows (Ref 6) in the two ports closest to you and one port furthest from you. Install the one 90° elbow (Ref 5) in the right hand port.
3. Install two 42-264 hydraulic hoses (Ref 3) on C and D. Tighten.
4. Install two 42-263 hydraulic hoses (Ref 1) on A and B. Be sure straight end of hose is on the valve with the fitting going backward. Tighten.
5. Remove mud guard and place a drain pan under the cross fittings that the hoses from the front wheel motor go to.
6. Disconnect the two hoses going to the front wheel motor at the cross, then at the front wheel motor and remove.
7. Remove the cover plate from the fiber glass.
8. Feed two 42-264 hydraulic hoses (Ref 3) up through bearing plate, through the 3" hole, and out to the front fork. Connect to the front wheel motor with the hose from D to the bottom of the wheel motor and C to the top.
9. Bolt valve to bearing plate with solenoid to your left side. Use the 1/4-20 x 2 bolt and flange whiz lock nut. Be sure to fasten the ground wire on one of the mounting bolts and the other end on one terminal of the solenoid valve.
10. Connect the two 42-263 hydraulic hoses (Ref 1) from the valve to the cross with the hose from A to the bottom cross and B to the top cross.
11. Install toggle switch on control panel. Uncoil green and white stripe wire from frame and hook on end to the toggle switch and the other end to the terminal on electric on/off valve. Install the loose end of the blue/white wire to the toggle switch.
12. Route hose and secure with 22-069 nylon ties. Reinstall mud guard.
13. Reconnect the negative (-) ground battery cable to battery and spark plug wires.
14. Make sure that everything is clear of the machine. Start the machine, test on/off valve for proper operation.
15. Check for hydraulic leaks.
16. Shut off machine, double check all fastener and fittings, be sure they are tight.
17. Reinstall cover plate.
18. Check hydraulic fluid, level should be 2 to 2 1/2 inches below the top of the tank when cold. Add if necessary.

DECAL LIST

This is a list of decals located on the Super Star. Part number, description and location will help in reordering decals.

13-556	Decal, Warning	1	Left Side Below Seat
25-277	Decal, Battery	1	Bottom Seat
25-286	Decal, Pinch Point	1	Bottom Seat Panel
25-298	Decal, Warning Hot	2	Bottom Seat Panel. Oil Filter Bracket
25-333	Decal, Emissions	1	Engine
25-337	Decal, Speed Boss	1	Hang from Steering
25-373	Decal, Smithco Star	1	Nose Cone
25-349	Decal, Foot Pedal	1	Right Side Nose Cone
25-352	Decal, By-Pass Valve	1	Hang Tag
25-384	Decal, Tire Pressure 8psi	3	Wheels
25-372	Decal, Smithco	1	Rear
25-361	Decal, Technical Assistance	1	Main Frame
27-077	Decal, Smithco Round	1	Steering Cap
43-110	Decal, Super Star	2	Nose Cone
42-765	Decal, Lift Control	1	Right Body Top
42-764	Decal, Control Panel	1	Left of Seat

OPTIONAL EQUIPMENT

42-011	Front Mounted Manual Plow	42-026	Stainless Steel Tournament Rake 84"
43-003	Hydraulic Sand Plow	42-128	Stainless Steel Tournament Rake 72"
42-136	Front Mounted 60" Manual Plow	42-130	Mild Steel Tournament Rake 84"
42-460	40" Adjustable Angle Plow	42-132	Mild Steel Tournament Rake 72"
42-490	60" Adjustable Angle Plow	42-391	72" Multi Brush Rake
43-130	Weed Cultivator	42-392	84" Multi Brush Rake
42-008	Sand Cultivator	13-438	Rake Assembly with Finishing Blades
42-340	Sand Cultivator w/ Spring Tine	13-684	Brush Kit (for 13-438)
42-341	Sand Cultivator w/ Castor Wheels	13-740	Brush Attachment - 84"
42-285	Scarifier w/ Vertical Blades	42-223	Edger Kit
42-010	Construction Leveling Blade	43-004	Grader Blade Kit
26-007	Professional Infield Finisher	42-794	Ball Mount Kit
26-008	Flex Action Field Finisher	42-750	Razor Edger Kit
43-043	Brush Kit (for 26-008)	13-319	Fan Rake Kit
43-002	Flex Action Field Finisher with Brush	13-298	Fan Rake Attachment
43-088	Drag Mat Kit	42-188	Drag Mat
42-315	Light Kit	42-800	ROPS
34-191	Box Grader		
42-178	Infield Scarifier (w/ Straight Blades & Castor Wheels)		
42-179	Infield Scarifier (w/ Chisel Blades & Castor Wheels)		
42-581	Green Star Roller Set (needs 42-586 main frame)		
42-582	Green Star Spiker Set (needs 42-586 main frame)		
42-585	Green Star Brush Set (needs 42-586 main frame)		
42-586	Green Star Main Frame		
42-550	Greens Star Roller, Brush, Spiker System with Main Frame		

QUICK REFERENCE REPLACEMENT PARTS

REPLACEMENT FILTERS

23-031	Hydraulic Oil Filter	
15-165-01	Air Filter Element with Pre-Cleaner	Briggs and Stratton# 5050
42-076-03	Air Filter Element Fender Mounted	
50-403	Fuel Filter	
13-531	Engine Oil Filter	Briggs and Stratton# 492932

SEAL KITS

42-002 and 42-039	Wheel Motors	
42-002-15	Seal Kit	
42-220	2-Bank Hydraulic Valve	
14-062	Seal Kit	
14-106	Relief Assembly Kit	
14-203	Spring Centering Assembly Kit (1 per bank)	
42-227	3-Bank Hydraulic Valve	
14-205	Seal Kit	
14-106	Relief Assembly Kit	
14-203	Spring Centered Assembly Kit (1 per bank)	
10-554	Hydraulic Cylinder (Attachment Lift Cylinder)	
14-529	Seal Kit	
14-534	Hydraulic Cylinder for Sand Plow Lift	
14-529	Seal Kit	
43-150	Hydraulic Cylinder for Rake Lift	
43-150-01	Seal Kit	

FLUIDS

Engine Oil	Refer to Engine Manual
Hydraulic Fluid	SAE 10W-40 API Service SJ or higher Motor Oil

OTHER PARTS

Spark Plugs	RC12YC (Gap 0.030 inch (0.76mm))
-------------	----------------------------------

The Smithco Commercial Products Two-Year Limited Warranty

Smithco, Inc. (Smithco) warrants your 2007 or newer Smithco Commercial Product (“Product”) purchased after January 1, 2007, to be free from defects in materials or workmanship for the period of time listed below. Where a warrantable condition exists, Smithco will repair the Product at no cost to you including diagnosis, labor (at the Smithco standard labor rate, subject to the Smithco flat rate schedule), and parts.

Warranty Duration is:

- (1) **Two years, 1500 operational hours* from the date of delivery to the original purchaser or three years from the date of original manufacturer of the product, whichever occurs first. (*Products equipped with hour meter).**
- (2) **Products used in rental situations are covered for 90 days from date of delivery to original user/renter.**

Owner Responsibilities:

As the Product owner, you are responsible for required maintenance and adjustments stated in your Owner’s Manual. Failure to perform required maintenance and adjustments can be grounds for disallowing a warranty claim. **You are particularly responsible to train all present and future operators of this product on the safe operation of this product at your location.**

Instructions for Obtaining Warranty Service:

You are responsible for notifying the Authorized Smithco Products Distributor from whom you purchased the Product as soon as you believe a warrantable condition exists and not later than 30 days from discovery of the condition.

If you need help locating an Authorized Smithco Distributor, or if you have questions regarding your warranty rights or responsibilities, you may contact us at:

Smithco Product Support Department
200 W Poplar PO Box 487
Cameron, Wisconsin 54822

Telephone: 1-800-891-9435 E-Mail: ProductSupport@smithco.com

Maintenance Parts:

Parts scheduled for replacement as required maintenance (“Maintenance Parts”), are warranted for the period of time up to the scheduled replacement time for that part.

Items/Conditions Not Covered:



Not all product failures or malfunctions that occur during the warranty period are defects in materials or workman-ship. The items/conditions listed below are not covered by this warranty:



Product failures which result from the use of non-Smithco replacement parts, or from installation and use of add-on, modified, or unapproved accessories are not cov-ered.



Product failures which result from failure to perform required maintenance and/or adjustments are not covered.



Product failures that result from operating the Product in an abusive, negligent or reckless manner are not covered.



This warranty does not apply to parts subject to con-sumption through use, unless found to be defective. Examples of parts which are consumed, or used up, during normal Product operation include, but are not limited to: blades, tines, teeth, scarifiers, rakes, plates, wear plates, castor wheels, tires, batteries, filters, belts, nozzles, etc.



This warranty does not apply to failures caused by out-side influence. Items considered to be outside influ-ence include, but are not limited to, weather, storage practices, contamination, use of unapproved coolants, lubricants, additives, or chemicals, etc.



This warranty does not apply to normal “wear and tear” items. Normal “Wear and Tear” includes, but is not limited to, damage to seats due to wear or abrasion, worn painted surfaces, scratched decals or windows, etc.



Smithco may require the return of failed parts or components in order to determine the validity of any warranty claim.



Smithco will not be obligated to replace components of other manufacturers if inspection by the original component manufacturer indicates that failure was due to normal wear and tear, expected consumption through use or improper care or service.

Other Legal Disclaimers:

The above remedy for product defects through repair or replacement by an authorized Smithco distributor or dealer is the purchaser’s sole remedy for any defect. This warranty gives you specific legal rights, and you may also have other rights which vary from state to state.

THERE ARE NO OTHER EXPRESS WARRANTIES OTHER THAN THOSE SET FORTH ABOVE. ALL IMPLIED WARRANTIES OF MERCHANTABILITY AND FITNESS FOR USE ARE LIMITED TO THE DURATION OF THE LIMITED WARRANTIES CONTAINED HEREIN.

Some states may not allow limitations on how long an implied warranty lasts, so the above limitation may not apply to you.

THE SMITHCO COMPANY IS NOT LIABLE FOR INDIRECT, INCIDENTAL OR CONSEQUENTIAL DAMAGES IN CONNECTION WITH THE USE OF THE PRODUCT, INCLUDING ANY COST OR EXPENSE OF PROVIDING A SUBSTITUTE PRODUCT OR SERVICE DURING PERIODS OF MALFUNCTION OR NON-USE.

Some states may not allow the exclusion of indirect, incidental or consequential damages, so the above exclusion may not apply to you.

Smithco neither assumes, nor authorizes any person to assume for it, any other liability in connection with the sale or use of this product.

SMITHCO, INC.

Wayne, PA 19087

