

Parts & Service



SweepStar V62
with Electric Clutch
78-200
SN: 78439

January 2009
Revised June 2010

Product Support:

Hwy 55 & Poplar Ave; Cameron WI 54822
1-800-891-9435 productsupport@smithco.com

CONTENTS

Introduction

Introduction 1-3

- Safe Practices 2
- Specifications 3
- Optional Equipment 3

Service

Service 4-11

- Maintenance 4-6
- Overloading Debris Hopper and Vacuum Housing Wear 7
- Service Chart Kawasaki 22hp 8
- End User's Service Chart 9
- Adjustments 10
- Tailgate Adjustments 11
- Storage 11

Diagrams

Diagrams 12-15

- Wiring Diagram 12-13
- Wiring Schematic 13

Parts

Parts 16-37

- Body and Frame 16-17
- Engine and Controls 18-19
- Pulley and Pump 20-21
- Blower and Vacuum Housing 22-23
- Finger Reel 24-25
- Brush Reel 26-27
- Reel and Hydraulic Pump 28-29
- Hopper 30-33
- 78-415 2-Bank Hydraulic Valve 34-35
- Rear Axle / Electric Brake 36-37

Accessories

Accessories 38-59

- 78-201 Replacement Brush Reel 38-39
- 78-202 Replacement Finger Reel 38-39
- 78-205 Remote Vacuum Hose 40-41
- 78-204 5th Wheel Hitch 42-43
- 78-206 Clevis Hitch 44-45
- 78-209 Ball Hitch 46-47
- 78-207 Hydraulic Lift Kit 48-49
- 78-416 3-Bank Hydraulic Valve 50-51
- 78-208 Filter System 52-53
- 78-210 & 78-211 Reel and Hydraulic Pump 54-55
- 78-210 Nylon Brush Head 56-57
- 78-211 Rubber Finger Head 58-59

Reference

Reference 61-62

- Decal List 61
- Quick Reference Replacement Parts 62
- Warranty Inside Back Cover

Thank you for purchasing a **SMITHCO** product.

Read this manual and all other manuals pertaining to the Sweep Star V62 carefully as they have safety, operating, assembly and maintenance instructions. Failure to do so could result in personal injury or equipment damage.

Keep manuals in a safe place after operator and maintenance personnel have read them. Right and left sides are from the operator's seat, facing forward.

All **SMITHCO** machines have a Serial Number and Model Number. Both numbers are needed when ordering parts. The serial number plate on the Sweep Star V62 is located on the left front frame. Refer to engine manual for placement of engine serial number.

For easy access record your Serial and Model numbers here.

SMITHCO			CE
WAYNE, PENNSYLVANIA 19087 USA 610-688-4009 Fax 610-688-6069			
SERIAL NO.	kW/hp	DATE OF MFG.	
<input type="text"/>	<input type="text"/>	<input type="text"/>	
MODEL NO.	lb/kg Empty	lb/kg Full	
<input type="text"/>	<input type="text"/>	<input type="text"/>	



Information needed when ordering replacement parts:

1. Model Number of machine
2. Serial Number of machine
3. Name and Part Number of part
4. Quantity of parts

1. It is your responsibility to read this manual and all publications associated with this machine (engine, accessories and attachments).
2. Never allow anyone to operate or service the machine or its attachments without proper training and instructions. Never allow minors to operate any equipment.
3. Learn the proper use of the machine, the location and purpose of all the controls and gauges before you operate the equipment. Working with unfamiliar equipment can lead to accidents.
4. Wear all the necessary protective clothing and personal safety devices to protect your head, eyes, ears, hands and feet. Operate the machine only in daylight or in good artificial light.
5. Inspect the area where the equipment will be used. Beware of overhead obstructions and underground obstacles. Stay alert for hidden hazards.
6. Never operate equipment that is not in perfect working order or without decals, guards, shields, or other protective devices in place.
7. Never disconnect or bypass any switch.
8. Carbon monoxide in the exhaust fumes can be fatal when inhaled, never operate a machine without proper ventilation.
9. Fuel is highly flammable, handle with care.
10. Keep engine clean. Allow the engine to cool before storing and always remove the ignition key.
11. Never use your hands to search for oil leaks. Hydraulic fluid under pressure can penetrate the skin and cause serious injury.
12. This machine demands your attention. To prevent loss of control or tipping of the vehicle:
 - A. Use extra caution in backing up the vehicle. Ensure area is clear.
 - B. Do not stop or start suddenly on any slope.
 - C. Reduce speed on slopes and in sharp turns. Use caution when changing directions on slopes.
 - D. Stay alert for holes in the terrain and other hidden hazards.
 - E. Run up and down slopes, never across the face.
13. Before leaving operator's position for any reason:
 - A. Disengage all drives.
 - B. Lower all attachments to the ground.
 - C. Shut engine off and remove the ignition key.
14. Keep hands, feet and clothing away from moving parts. Wait for all movement to stop before you clean, adjust or service the machine.
15. The rubber fingers, sweeper and vacuum pick up and propel debris and small objects in its path during operation. Keep the area of operation clear of all bystanders.
16. Never carry passengers.
17. Stop engine before making repairs/adjustments or checking/adding oil to the crankcase.
18. Use parts and materials supplied by SMITHCO only. Do not modify any function or part.
19. Do not remove the radiator cap when the engine is hot. When cooled, loosen cap slightly to the stop to relieve any pressure before removing the cap completely.
20. Avoid sharp turns. Watch the tires of the tractor while turning to make sure they do not contact the tongue of the Sweep Star V62.
21. Shut down power source before attempting to unclog any part of the machine.
22. If reel deck begins to vibrate abnormally, immediately shut off power and determine the cause.
23. Do not tow on public roads.

These machines are intended for professional maintenance on golf courses, sports turf, and any other area maintained turf and related trails, paths and lots. No guaranty as to the suitability for any task is expressed or implied.



SPECIFICATIONS FOR SWEEP STAR V62

WEIGHTS AND DIMENSIONS

Length	151" (384 cm)
Width	68" (172 cm)
Height	87" (221 cm)
Weight	1500 lb (680 kg)

SOUND LEVEL

At ear level	98 dBA
At 30 ft (9.14m)	92.5 dBA

ENGINE

Make	Briggs & Stratton
Model#	543477
Type/Spec	0160E1
Horsepower	31 Hp (23 kW)
Fuel	Unleaded 87 Octane Gasoline Minimum
Cooling System	Air Cooled
Lubrication System	Full Pressure
Alternator	15 Amp

TIRES & WHEELS

Two 24 x 13.00 x 12 NHS (18 psi (1.3 bar))
Castor: 9 x 3.5 x 4 (20 psi (1.4 bar))

BATTERY (optional)

Automotive type	45- 12 volt
BCI Group	Size 45
Cold Cranking Amps	480 minimum
Ground Terminal Polarity	Negative (-)
Maximum Length	9" (23 cm)
Maximum Width	5.38" (14 cm)
Maximum Height	9" (23 cm)

FLUID CAPACITY

Crankcase Oil	See Engine Manual
Fuel	5 gallon (19 liters)
Hydraulic Fluid	3.2 gallon (12.2 liters)
Cooling	2.8 quarts (2.7 liters)
Grade of Hydraulic Fluid	SAE 10W-40 API Service SJ or higher Motor Oil

OPTIONAL EQUIPMENT

78-201 Replacement Brush Reel	78-207 Hydraulic Lift System
78-202 Replacement Finger Reel	78-208 Filter System
78-203 Hard Surface Sweeper	78-209 Ball Hitch
78-204 5 th Wheel Hitch	78-210 Nylon Brush Head
78-205 Remote Vacuum Hose	78-211 Rubber Finger Head
78-206 Clevis Hitch	22-073 Battery
78-215 Electric Brake	



MAINTENANCE



Before servicing or making adjustments to machine, stop engine and remove key from ignition.

Use all procedures and parts prescribed by the manufacturer's. Read the engine manual before operation.

LUBRICATION

Use No. 2 General Purpose Lithium Base Grease and lubricate every 100 hours. The Sweep Star V62 has seventeen grease fittings. All bearings are sealed bearings. When inserting grease, be careful not to ruin the seal, if this happens, replace the bearing at once.

Be sure to wipe grease fitting clean before injecting grease. Give only one or two pumps of grease at each lubrication.

REF#	LOCATION
1	One on all four castor wheels.
2	One on right and left hopper door arms.
3	One on each mounted bearing for reel shaft.
4	One on right and left deck lift arm.
5	one on all four castor wheel mount brackets.
6	One on the jack stand.
7	Two on machine control panel that go to the blower shaft mounted bearing.

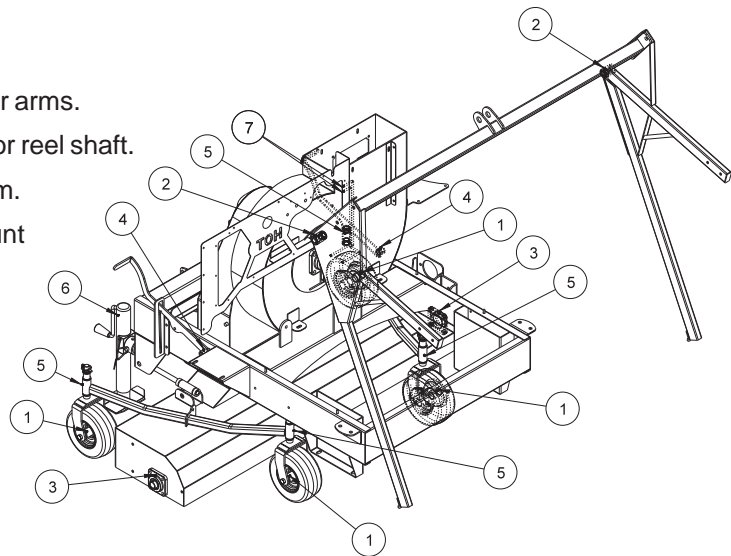

HYDRAULIC OIL

1. Use SAE 10W-40 API Service SJ or higher motor oil.
2. For proper warranty, change oil every 500 hours or annually, whichever ever is first and change the filter after the first 20 hours, then at 100 hours, then every 250 hours thereafter.
3. The oil level should be 2" to 2¹/₂" from top of the tank when fluid is cold. Do not overfill.
4. After changing oil and/or filter, run the machine for a few minutes. Check oil level and for leaks.
5. Always use caution when filling hydraulic oil tank or checking level to keep system free of contaminants. Check and service more frequently when operating in extremely cold, hot or dusty conditions.
6. If natural color of fluid is now black or smells burnt, it is possible that an overheating problem exists.
7. If fluid becomes milky, water contamination may be a problem.
8. If either of the above conditions happen, change oil and filter immediately after fluid is cool and find cause. Take fluid level readings when system is cold.
9. In extreme temperatures you can use straight weight oil. We recommend SAE 30W API Service SJ or higher when hot (above 90°F (33°C)) and SAE 10W API Service SJ or higher when cold (below 32°F (0°C)) ambient temperature. Use either motor oil or hydraulic oil, but do not mix.
10. Oil being added to the system must be the same as what is already in the tank. Mark tank fill area as to which type you put in.

TIRE PRESSURE

Caution must be used when inflating a low tire to recommended pressure. Over inflating can cause tires to explode. Tires on the machine should be 18 psi (1.3 bar), castor wheels should be 20 psi (1.4 bar). Improper inflation will reduce tire life considerably.

ENGINE OIL

Change and add oil according to charts below. Do not overfill. Use a high quality detergent oil. For Briggs engine use oil classified "For Service SJ or higher" SAE 30 oil. Use no special additives with recommended oils. Do not mix oil with gasoline.

SAE 30 oil, if used below 40° F (4° C), will result in hard starting and possible engine bore damage due to inadequate lubrication.

The use of non-synthetic multi-viscosity oils in temperatures above 40°F (4° C) will result in higher than normal oil consumption. Check oil level more frequently when using a multi-viscosity oil.

SAE VISCOSITY GRADES

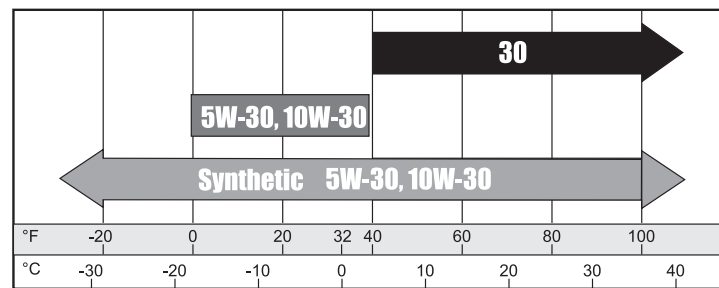

Starting Temperature Range Anticipated Before Next Oil Change

WHEEL MOUNTING PROCEDURE

MACHINE WHEELS

1. Turn machine off and remove key.
2. Be sure unit is on a level surface. Unhitch from tow vehicle if possible.
3. Block the opposite wheel then the one you are working on.
4. Loosen nuts slightly on wheel to be removed.
5. Jack up machine being careful not to damage underside of machine.
6. Remove nuts, remove wheel.
7. Place new wheel on hub lining up bolt holes.
8. Torque nuts to 64-74 ft/lb (87-100 Nm) using a cross pattern. Torque again after first 10 hours and every 200 hours thereafter.
9. Lower machine to ground and remove blocks and jack.

FILTER SYSTEM

Filter pack may be cleaned by shaking or spraying off with low pressure water. Filter will disintegrate if high pressure is used on it.

MAINTENANCE (CONTINUED)

BATTERY

Batteries normally produce explosive gases which can cause personal injury. Do not allow flames, sparks or any ignited object to come near the battery. When charging or working near battery, always shield your eyes and always provide proper ventilation.

Battery cable should be disconnected before using "Fast Charge".

Charge battery at 15 amps for 10 minutes or 7 amps for 30 minutes. Do not exceed the recommended charging rate. If electrolyte starts boiling over, decrease charging.

Always remove grounded (-) battery clamp first and replace it last. Avoid hazards by:

1. Filling batteries in well-ventilated areas.
2. Wear eye protection and rubber gloves.
3. Avoid breathing fumes when electrolyte is added.
4. Avoid spilling or dripping electrolyte.



Battery Electrolyte is an acidic solution and should be handled with care. If electrolyte is splashed on any part of your body, flush all contact areas immediately with liberal amounts of water. Get medical attention immediately.

JUMPSTARTING



Use of booster battery and jumper cables. Particular care should be used when connecting a booster battery. Use proper polarity in order to prevent sparks.

To jump start (negative grounded battery):

1. Shield eyes.
2. Connect ends of one cable to positive (+) terminals of each battery, first (A) then (B).
3. Connect one end of other cable to negative (-) terminal of "good" battery (C).
4. Connect other end of cable (D) to engine block on unit being started (NOT to negative (-) terminal of battery)

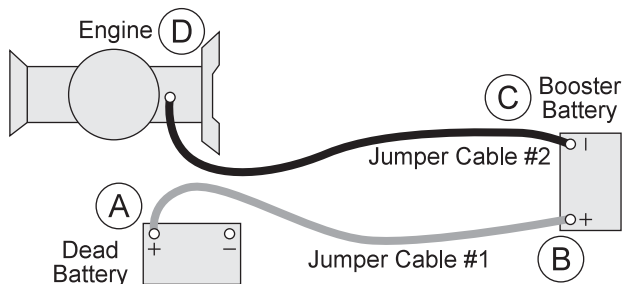

To prevent damage to other electrical components on unit being started, make certain that engine is at idle speed before disconnecting jumper cables.

OVERLOADING DEBRIS HOPPER AND WEAR ON VACUUM HOUSING

OVERLOADING DEBRIS HOPPER

Smithco Sweeper-Vacs are designed to carry the following maximum loads:

Model 72-000 Big Vac	1500 lbs. (608 kg)
Model 78-200 & 78-500 Sweep Star V62	860 lbs. (400 kg)

PLEASE NOTE THE FOLLOWING:

1. Loads heavier than that will damage the unit.
2. Such damage is not covered by warranty.
3. Overloading is particularly easy when collecting aerifier cores.
4. The hoppers on the Big Vac and V62 are large in order to hold 7 and 4 cubic yards respectively, of thatch, grass clippings, leaves and trash.
5. They will not hold 7 or 4 cubic yards of aerifier cores.
6. The maximum depth (in the debris hopper) of aerifier cores is:

Model 72-000 Big Vac	12 in. (30 cm)
Model 78-200 & 78-500 Sweep Star V62	40 in. (101 cm)

VACUUM HOUSING WEAR

The Big Vac & V62 are fitted with a wear resistant liner in the vacuum housing. This will provide additional housing life. Be sure the following points are explained to the user:

1. The vacuum housing and impeller must be cleaned each time the unit is used so the housing liner is inspected daily. Only Smithco Sweeper-Vacs provide a clean out/inspection port for easy inspection and cleaning.
2. When bare steel is visible at any point in the housing lining, the lining must be replaced. It is expected the liner will wear and be replaced. It is a vast improvement over competitive units with no liners.
3. Replacement of the liner or the vacuum housing due to wear is normal and is not covered by warranty.
4. Collection of aerifier cores causes extreme wear on the liner (and if unchecked, on the housing).
5. Caution users that, while Smithco Sweeper-Vacs do an excellent job collecting cores, the lining (and the housing) will wear quickly in such use.

RUBBERIZED BOOT

The rubberized boot between main unit and sweeper head is subject to wear and damage from debris. Unless defective, replacement of this boot is not covered by warranty.

MAXIMUM LOAD CAPACITY

There are decals on each side of the hopper to indicate the maximum depth of aeration cores. The maximum depth for aeration cores in the hopper is 40" (101 cm). The maximum depth of sand and dirt in hopper is 20" (50cm). The maximum load capacity of the Sweep Star V-62 is 860 lbs (400 kg).

Overloading will cause damage that is not covered by the warranty.



SERVICE CHART



Before servicing or making adjustments to the machine, stop engine, set park break, block wheels and remove key from ignition.



Follow all procedures and **ONLY** use parts prescribed by the manufacturer. Read the engine manual before maintenance.

The suggested maintenance checklist is not offered as a replacement for the manufacturer's engine manual but as a supplement. You must adhere to the guidelines established by the manufacturer for warranty coverage. In adverse conditions such as dirt, mud or extreme temperatures, maintenance should be more frequent.

Maintenance Service Interval	Maintenance Procedure
After the first 8 operating hours	Torque the wheel lug nuts. (64-74 ft/lb (87-100 Nm))
	Change the engine oil filter.
	Change the hydraulic filter.
After the first 20 operating hours	Change oil filter after first 20 and first 100 hours.
Before each use daily	Check the engine oil.
	Check the hydraulic fluid level.
	Check the tire pressure.
	Check condition of hydraulic hoses and fittings.
	Inspect and clean the machine.
Every 25 hours	Inspect cooling system.
	Check the battery fluid level and cable connections.
	Lubricate castor Wheels
Every 50 hours	Change oil when operating under heavy load or high
	Change the engine oil and filter.
Every 100 hours	Check engine for leaks or loose parts.
	Check air cleaner.
	Check tire pressure (5 psi (.035 bar)).
	Torque the wheel lug nuts. (64-74 ft/lb (87-100 Nm))
	Grease Machine.
Every 250 hours	Check belt tension (where needed)
	Change oil filter
	Change hydraulic filter
	Lubricate reel and blower shaft bearings
Every 400 hours	Clean battery terminals
	Check spark plugs
Every 500 hours or yearly	Lubricate machine
	Visual inspection of machine and hydraulic hoses
	Change oil.
	Torque lug nuts.
	Check battery terminals and electrolyte level.
	Change all filters.

ADJUSTMENTS

ADJUSTMENT OF BELT TENSIONER

There are two belt tensioners on the Sweep Star V62. One controls the tension on the belt from the engine to blower shaft the other controls the belt on the finger or brush reel. The proper tension of the idler should be 12 to 15 as per the gauge (A) on the side of the tightener. Over tightening the belt will shorten the life of the belt and the machine may not perform to the best of its ability. To adjust belt tensioner, loosen bolt holding tensioner. Bring idler pulley tight to belts and turn tensioner into belts to 15°. Tighten holder bolt.

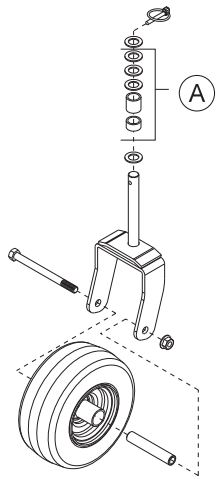
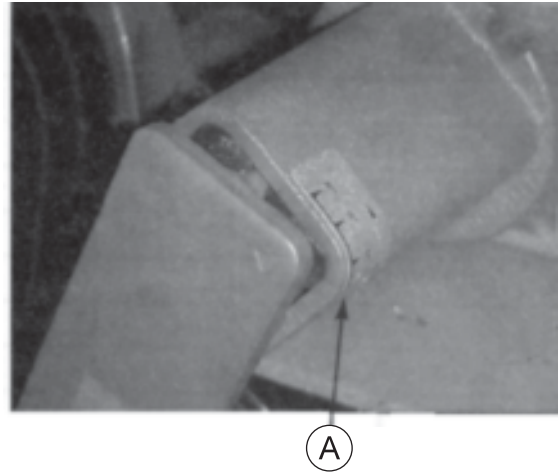

CASTOR WHEELS

Install castor wheels onto the brush/finger head assembly. You may put the machine bushings and spacers (A) on in any combination to get desired height. You should leave one machine bushing on the very bottom and one on the very top next to the lockpin. Check the tire pressure on Castor Wheels they should be 20 psi (1.4 bar).

DRAIN

The drain is used to flush out any water or debris that accumulates in the bottom of the blower housing.

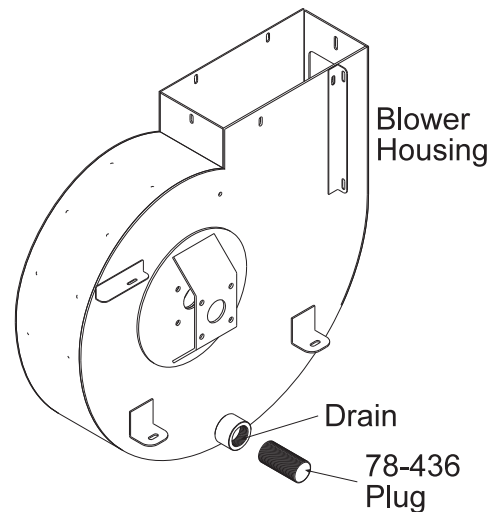

V62 TAILGATE LEVELING

If the tailgate is not sitting level against the hopper it can be leveled by loosening the $\frac{3}{8}$ inch bolts that hold the pivot bracket to the upper lift arms then rotate the pivot brackets until tailgate level then tighten. Once it is level it must be readjusted using steps 1, 2 and 3.

V62 TAILGATE ADJUSTMENT PROCEDURE

1. Open tailgate approximately 10 inches and shut off engine. Locate the $\frac{3}{8}$ inch bolts that connect the lower lift arm to the tailgate (Connected by springs). Loosen them about $1\frac{1}{2}$ turns.
2. Find at top corners of the tailgate the $\frac{1}{2}$ inch bolt that connects the upper lift arms to the tailgate. Loosen both sides then push the tailgate in towards the hopper. The bolts will slide in the slots of the brackets on the end of the lift arms when pushed tight against the hopper. Tighten the outside nut just tight enough to hold it from moving in the slot, repeat on other side. (Do not over tighten).
3. Start the machine move the valve handle to the lower position and close the tailgate, as the tailgate comes in contact with the hopper it will push the top of the tailgate outward in the slots in the top lift arm as the bolts slide outward in the slots. As the bolts slide outward in the slots the tailgate will also glide downward approximately $\frac{1}{2}$ inch. Check to see that the tailgate fits tight against the hopper. Then tighten the nuts together on both of the top corners of the tailgate using two $\frac{3}{4}$ inch wrenches. Then tighten the nuts on the $\frac{3}{8}$ inch bolts on the lower sides of the tailgate using two $\frac{9}{16}$ inch wrenches.

STORAGE

When storing, remove the key from the key switch to avoid unauthorized persons from operating machine.

1. Before storing clean machine thoroughly.
2. Check bolts and nuts, tighten as necessary.
3. Make all repairs that are needed and remove any debris.
4. Remove the battery, adjust the electrolyte level and recharge it. Store the battery in a dry, dark place.
5. Store in a clean and dry area, but NOT near a stove, furnace or water heater which uses a pilot light or any device that can create a spark.
6. Engines stored over 30 days need to be protected or drained of fuel to prevent gum from forming in a fuel system or on essential carburetor parts. Check the engine manual and follow the instructions for the storage of the engine.

WIRING DRAWING

Diagrams

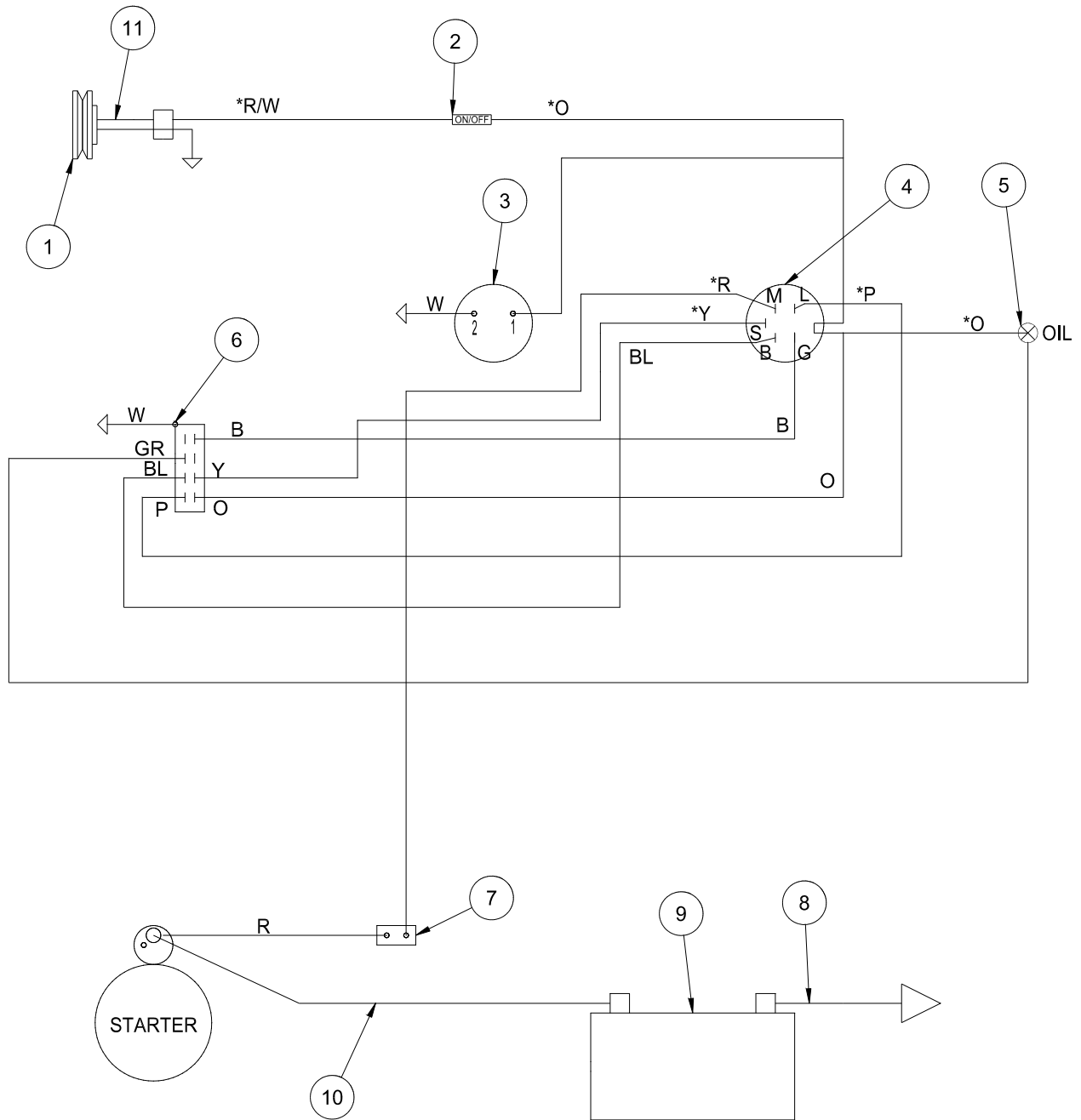

WIRING PARTSLIST

REF#	PART#	DESCRIPTION	QUANTITY
1	78-368	Electric Clutch	1
2	15-314	Toggle Switch	1
	15-472	Switch Boot	1
3	12-017	Hour Meter	1
4	13-488	Ignition Switch	1
5	50-359	Oil Light	1
	8874	Female Bullet Connector	1
	8875	Male Bullet Connector	1
	8963	Heat Shrink	2
6		Plug on Engine	1
7	8975	30 Amp Circuit Breaker	1
	8977	Circuit Breaker Boot	1
8	22-054	Battery Cable Black	1
9	22-073	Battery (optional)	1
10	78-325	Red Battery Cable with Boot	1
11	17-271	Pigtail Harness for Electric Clutch	1
	78-442	Wire Harness (includes all wire colors with *)	

HYDRAULIC DRAWING

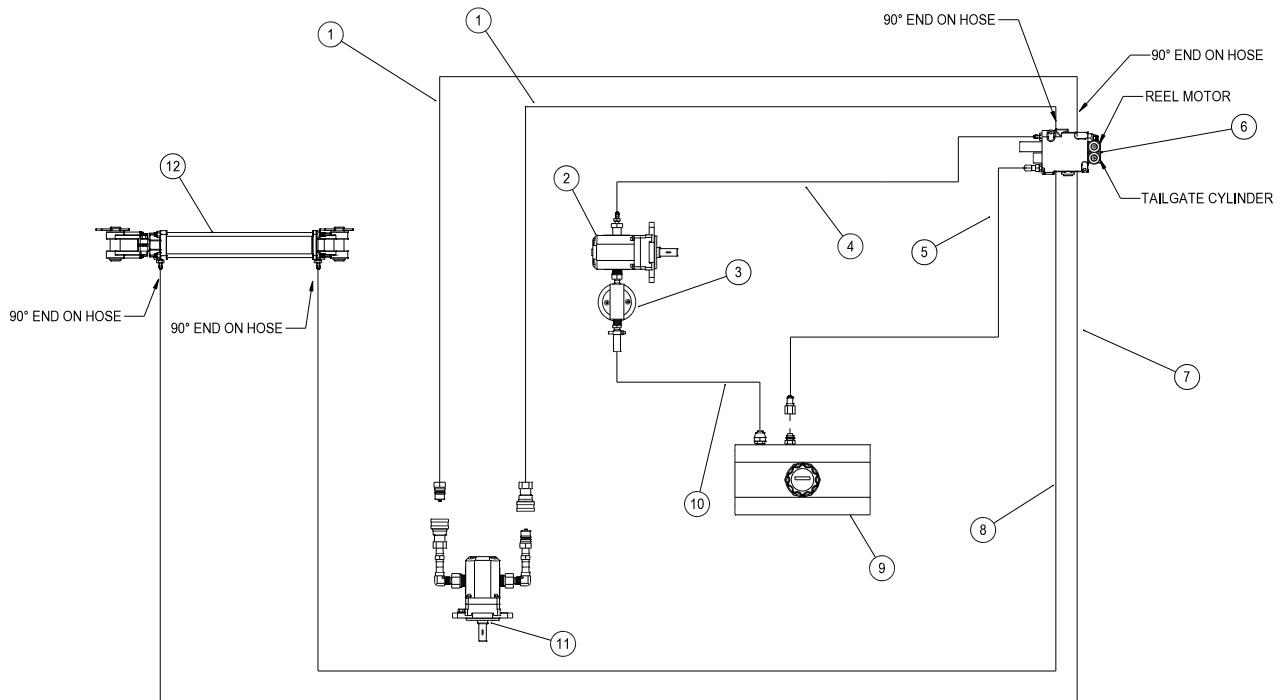

Diagrams

HYDRAULIC PARTSLIST

REF#	PART#	DESCRIPTION	QUANTITY
1	78-247	Hydraulic Hose (brush motor to valve)	2
2	78-413	Hydraulic Pump	1
3	23-006	Oil Filter	1
	23-031	Filter Element (replacement only)	1
4	78-249	Hydraulic Hose (pump to valve)	1
5	78-250	Hydraulic Hose (return to tank)	1
6	78-415	2-Bank Hydraulic Valve	1
7	78-246	Hydraulic Hose (rear hyd. cyl. to front valve)	1
8	78-248	Hydraulic Hose (front hyd. cyl. to rear valve)	1
9	13-584	Oil Tank	1
10	8917-14	Suction Hose $\frac{5}{8}$ ID x 14	1
	18-040	Hose Clamp	2
11	78-414	Hydraulic Motor	1
12	75-714	Hydraulic Cylinder	1

HYDRAULIC PRESSURES

Pump Displacement	.4 in ³ /rev
Pump Input Speed (up to)	3600 rpm
Max. Operating Pressure	2500 psi
Max. Inlet Vacuum	10 in. Hg
Max. Case Pressure	80 psi
78-415 Hydraulic Valve (2 bank)	2500 psi

BODY AND FRAME DRAWING

Parts

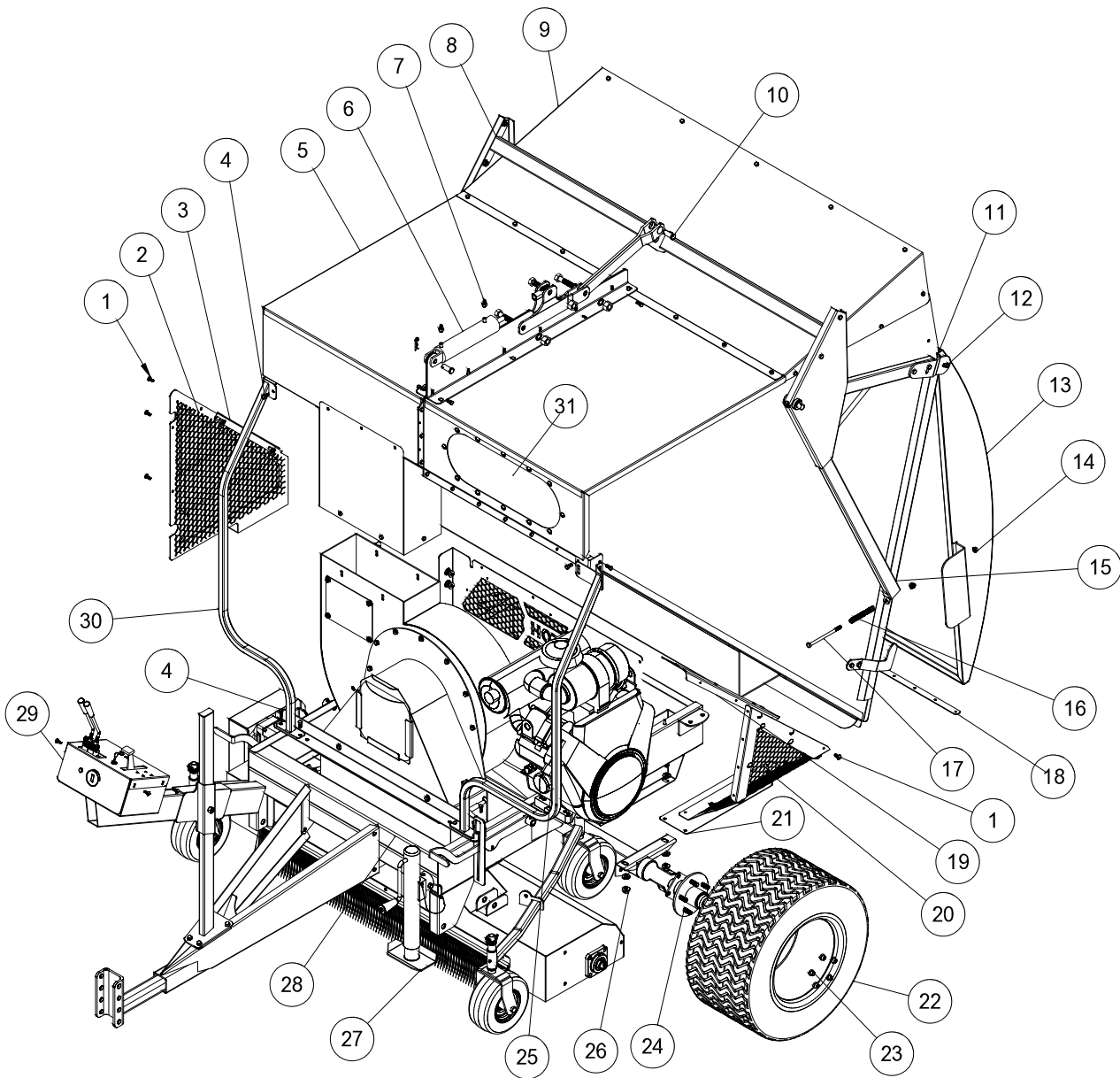

BODY AND FRAME PARTS LIST

REF#	PART#	DESCRIPTION	QUANTITY
1	HSTP-14-20-075	Phillips Truss Head Machine Screw $\frac{1}{4}$ - 20 x $\frac{3}{4}$	8
2	78-253	Right Guard	1
	78-274	Cage Nuts	2
3	78-315	Right Guard Mount	1
	78-274	Cage Nuts	2
	HBFL-516-18-075	Flange Bolt $\frac{5}{16}$ - 18 x $\frac{3}{4}$	2
	HNFL-516-18	Flange Whiz Lock Nut $\frac{5}{16}$ - 18	2
4	HBFL-516-18-075	Flange Bolt $\frac{5}{16}$ - 18 x $\frac{3}{4}$	8
	HNFL-516-18	Flange Whiz Lock Nut $\frac{5}{16}$ - 18	8
5	78-260	Right Hopper	1
6	75-714	Hydraulic Cylinder	1
	14-254	Seal Kit	1
7	18-169	Adapter $\frac{3}{8}$ SAE	2
8	78-265	Cross Bar	1
9	78-272	Hopper Cover	1
10	HCP-58-175	Clevis Pin $\frac{5}{8}$ x $1\frac{3}{4}$	2
	HHP-18-100	Cotter Pin $\frac{1}{8}$ x 1	2
11	78-319	Hopper Door Adjustment	2
12	HNFL-12-13	Flange Whiz Lock Nut $\frac{1}{2}$ - 13	4
	HW-12	Washer $\frac{1}{2}$	4
	HB-12-13-250	Bolt $\frac{1}{2}$ - 13 x $2\frac{1}{2}$	2
13	78-266	Hopper Door	1
14	HNFL-38-16	Flange Whiz Lock Nut $\frac{3}{8}$ - 16	4
15	78-264	Left Door Arm	1
16	19-205	Spring	2
17	HB-38-16-575	Bolt $\frac{3}{8}$ - 16 x $5\frac{3}{4}$	2
18	78-387	Weatherstripping Bracket	2
	8979-61	Door Weatherstripping	2
	HSD-8-050	Drill Screw #8 x $\frac{1}{2}$	32
19	78-448	Left Guard Mount	1
	78-274	Cage Nuts	3
	HBFL-516-18-075	Flange Bolt $\frac{5}{16}$ - 18 x $\frac{3}{4}$	3
	HNFL-516-18	Flange Whiz Lock Nut $\frac{5}{16}$ - 18	3
20	78-339	Left Guard	1
	78-274	Cage Nuts	4
21	78-447	LH Guard Extension	1
22	78-221	Tire and Wheel	2
	78-221-01	Tire 24 x 13 -12 6 Ply	2
	78-221-02	Wheel	2
23	HNL-12-20	Lug Nut $\frac{1}{2}$ - 20 (part of 78-216)	10
24	78-216	Rear Axle	1
25	78-444	Left Brush Guard	1
26	HB-12-13-150	Bolt $\frac{1}{2}$ - 13 x $1\frac{1}{2}$	4
	HW-12	Washer $\frac{1}{2}$	4
	HNTL-12-13	Lock Nut $\frac{1}{2}$ - 13	4
27	78-240	Jack	1
28	78-449	Main Frame	1
	HLC-A-200	Loom Clamp	4
	HSDPS-14-075	Stainless Steel Pan Head Drill Screw $\frac{1}{4}$ x $\frac{3}{4}$	4
29	78-446	Operator Control Panel	1
30	78-269	Right Brush Guard	1
31	78-345	Clear Lexan Window	1

ENGINE AND CONTROLS DRAWING

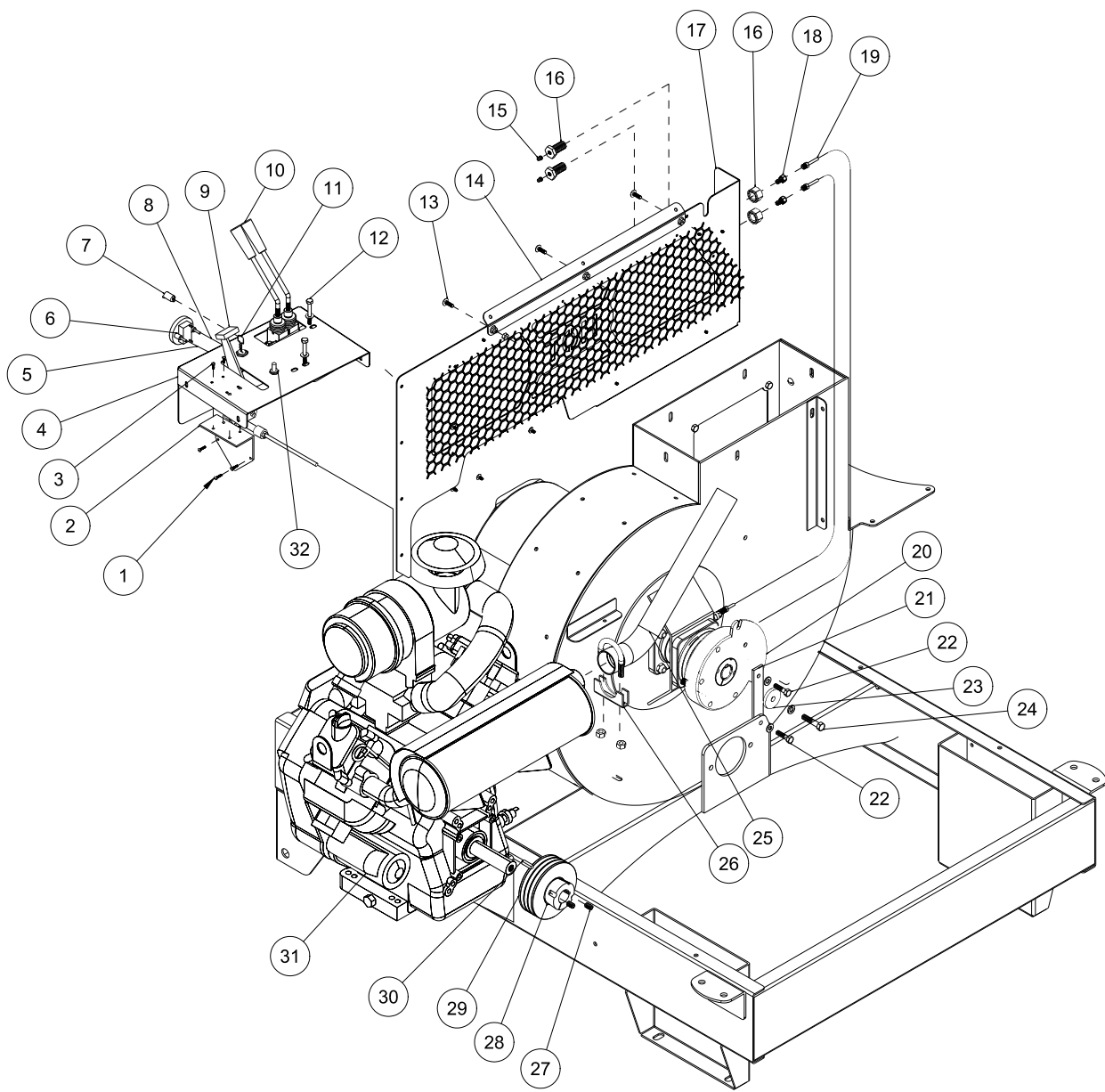

Parts

ENGINE AND CONTROLS PARTS LIST

REF#	PART#	DESCRIPTION	QUANTITY
1	HSM-10-32-063	Machine Screw #10 - 32 x 5/8	4
	HWL-10	Lockwasher #10	4
	HNFL-10-32	Flange Whiz Lock Nut #10 - 32	4
2	34-159	Throttle Mounting Bracket	1
3	HSM-10-32-063	Machine Screw #10 - 32 x 5/8	4
	HWL-10	Lockwasher #10	4
	HN-10-32	Flange Whiz Lock Nut #10 - 32	4
4	78-446	Operator Control Panel V62	1
	78-217	Decal, Operator Control Panel V62	1
	HSTP-14-20-075	Phillips Truss Head Machine Screw 1/4 - 20 x 3/4	4
	HNFL-14-20	Flange Whiz Lock Nut 1/4 - 20	4
5	78-342	Wire, Hour Meter to Ground	1
	HN-14-20	Nut 1/4 - 20	1
6	12-017	Hour Meter	1
7	78-340	Oil Light	1
8	78-343	Wire, Hour Meter to Buss Bar	1
9	78-337	Throttle	1
	HN-38-24	Nut 3/8 - 24	2
10	78-415	2-Bank Valve	1
	78-418	Bent Handle	2
11	13-488	Ignition Switch	1
12	HB-14-20-200	Bolt 1/4 - 20 x 2	2
	HW-14	Washer 1/4	2
	HNFL-14-20	Flange Whiz Lock Nut 1/4 - 20	2
13	HSTP-14-20-075	Phillips Truss Head Machine Screw 1/4 - 20 x 3/4	8
	HNFL-14-20	Flange Whiz Lock Nut 1/4 - 20	8
14	78-317	Front Guard Mount	1
15	HG-18-45	Grease Fitting 1/8 Pipe x 45°	2
16	18-339	Anchor Coupling	2
17	78-445	Front Guard	1
18	18-338	Male Connector	2
19	78-324	3/16 Brake Line 20"	2
20	78-368	Electric Clutch	1
21	76-340	Clutch Strap	1
22	HB-516-18-100	Bolt 5/16 - 18 x 1	2
	HW-516	Washer 5/16	3
	HNTL-516-18	Lock Nut 5/16 - 18	2
23	78-370	Washer	1
24	HB-38-16-125	Bolt 3/8 - 16 x 1 1/4	1
	HWL-38	Lockwasher 3/8	1
25	15-651	Exhaust Pipe	1
26	50-359	Muffler Clamp 1 1/4	1
27	HSSHS-38-16-063	Set Screw 3/8 - 16 x 5/8 (part of 78-427)	2
28	78-427	Hub 1 1/8	1
29	78-424	Pulley	1
30	HKSQ-14-100	Machine Key 1/4 x 1/4 x 1	1
31	76-446	Engine, 31 HP Briggs & Stratton	1
	76-448	Muffler	1
32	15-314	Toggle Switch	1
	15-472	Switch Boot	1



PULLEY AND PUMP DRAWING

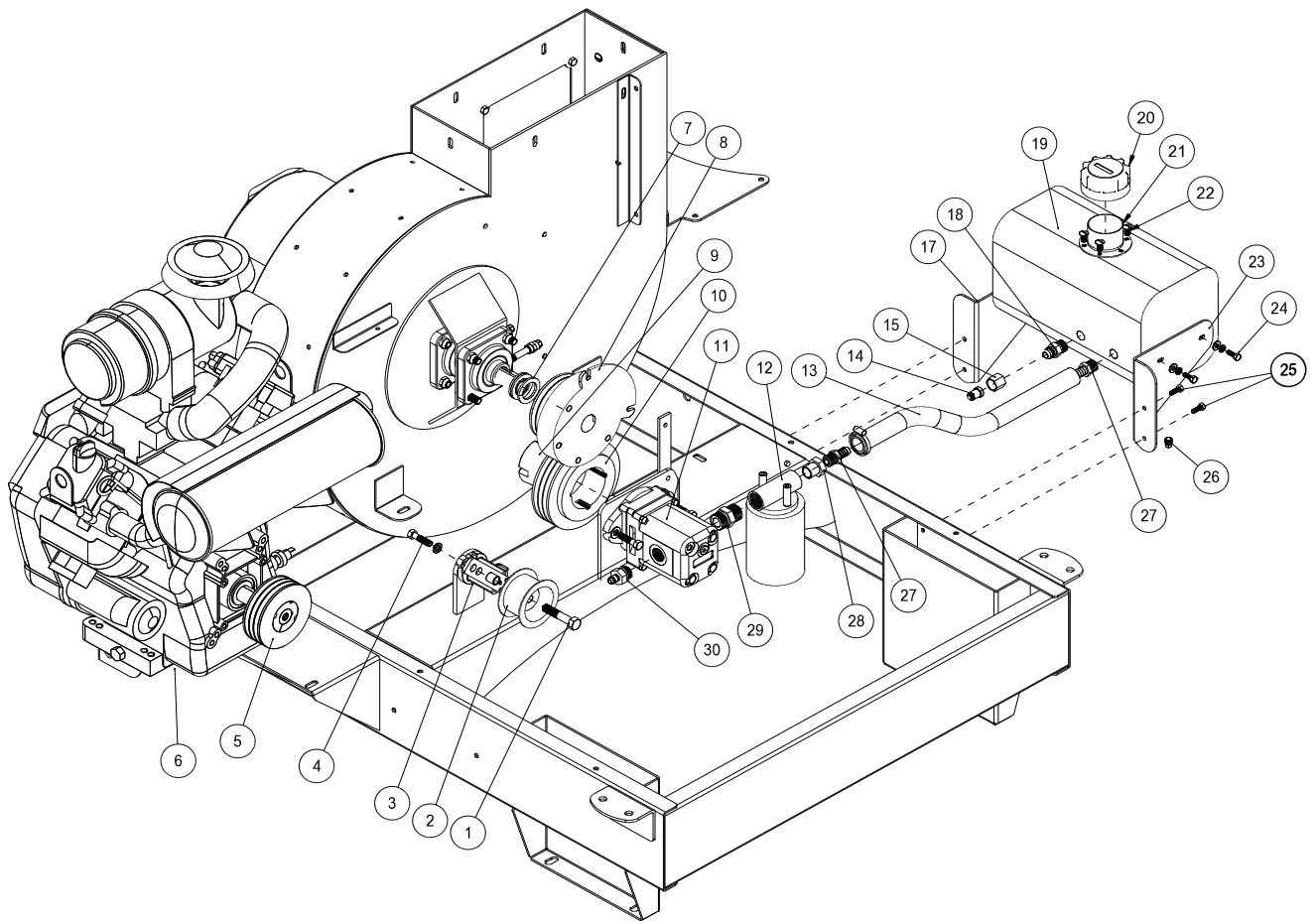

Parts

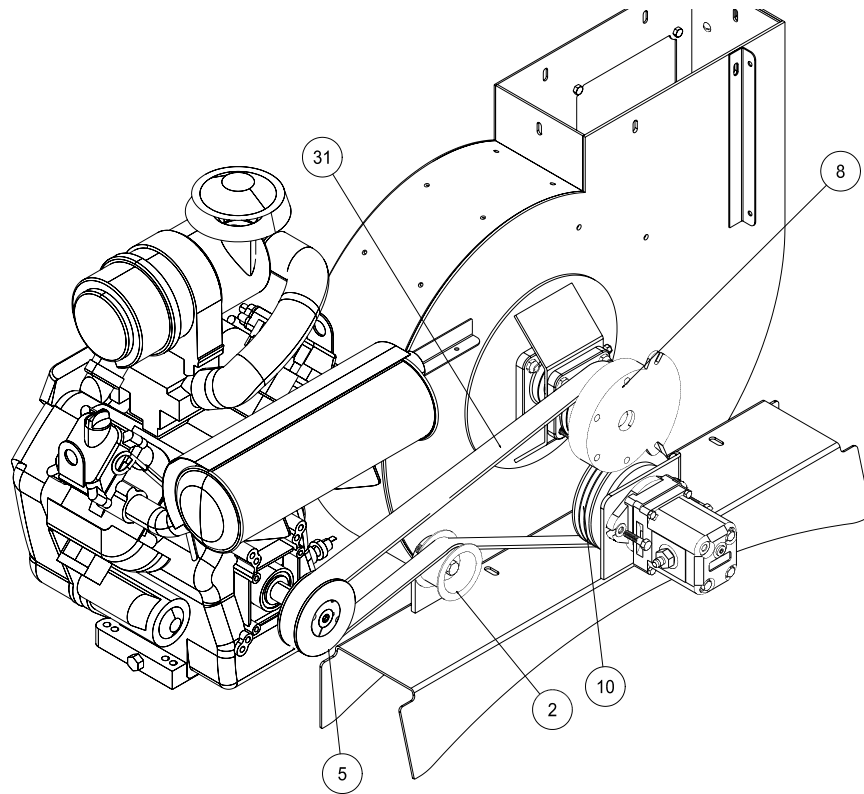

PULLEY AND PUMP PARTS LIST

REF#	PART#	DESCRIPTION	QUANTITY
1	HB-12-13-250	Bolt $\frac{1}{2}$ - 13 x $2\frac{1}{2}$ (part of 78-224)	1
	HMB-12-14	Machine Bushing $\frac{1}{2}$ - 14GA	2
	78-275	Spacer (part of 78-224)	1
	HNCL-12-13	Center Lock Nut $\frac{1}{2}$ - 13 (part of 78-224)	1
2	16-013	Idler Pulley	1
3	78-224	Belt Tensioner	1
4	HBM-10-1.5-30	Metric Bolt 10-1.5 x 30 (part of 78-224)	1
	HWLM-10	Metric Lockwasher #10 (part of 78-224)	1
5	78-424	Pulley	1
	78-427	Hub $1\frac{1}{8}$	1
	HSSHS-38-16-063	Set Screw $\frac{3}{8}$ - 16 x $\frac{5}{8}$ (part of 78-427)	2
6	76-446	Engine, 31 HP Vanguard	1
	76-448	Muffler	1
7	HMB-114-10	Machine Bushing 11/4 x 10GA	1
8	78-368	Electric Clutch	1
9	42-246	Hub $\frac{3}{4}$	1
	HSSHS-12-13-100	Set Screw $\frac{1}{2}$ - 13 x 1	2
10	78-426	Pulley 3-Groove (pump)	1
11*	78-413	Hydraulic Pump	1
	HWK-316-063	Woodruff Key $\frac{3}{16}$ x $\frac{5}{8}$	1
	HB-38-16-150	Bolt $\frac{3}{8}$ - 16 x $1\frac{1}{2}$	2
	HW-38	Washer $\frac{3}{8}$	4
	HNTL-38-16	Lock Nut $\frac{3}{8}$ - 16	2
12	23-006	Oil Filter	1
	23-031	Replacement Filter Only	
13	8917-14	Suction Hose $\frac{5}{8}$ ID	1
	18-040	Hose Clamp	2
14	18-229	90° Elbow	1
15	18-362	Adapter	1
17	78-278	Front Oil Tank Bracket	1
18	23-121	Fitting	1
19	13-584	Oil Tank	1
20	13-747	Filter Breather	1
21	13-586-03	Neck	1
22	HSTC-10-32-050	Self Cutting Screw 10 -32 x $\frac{1}{2}$	6
23	78-277	Rear Oil Tank Bracket	1
24	HB-14-20-075	Bolt $\frac{1}{4}$ - 20 x $\frac{3}{4}$	4
	HWL-14	Lockwasher $\frac{1}{4}$	4
	HW-14	Washer $\frac{1}{4}$	4
25	HB-14-20-075	Bolt $\frac{1}{4}$ - 20 x $\frac{3}{4}$	4
	HNFL-14-20	Flange Whiz Lock Nut $\frac{1}{4}$ - 20	4
26	18-118	Pipe Plug $\frac{1}{8}$	1
27	23-139	Barb Fitting	2
28	18-008	Pipe Reducer	1
29	18-332	Adapter	1
30	18-331	Adapter	1
31	78-443	Belt, 3-V	1

*

NO OTHER PARTS ARE REPLACEABLE FOR HYDRAULIC PUMP.



BLOWER AND VACUUM HOUSING DRAWING

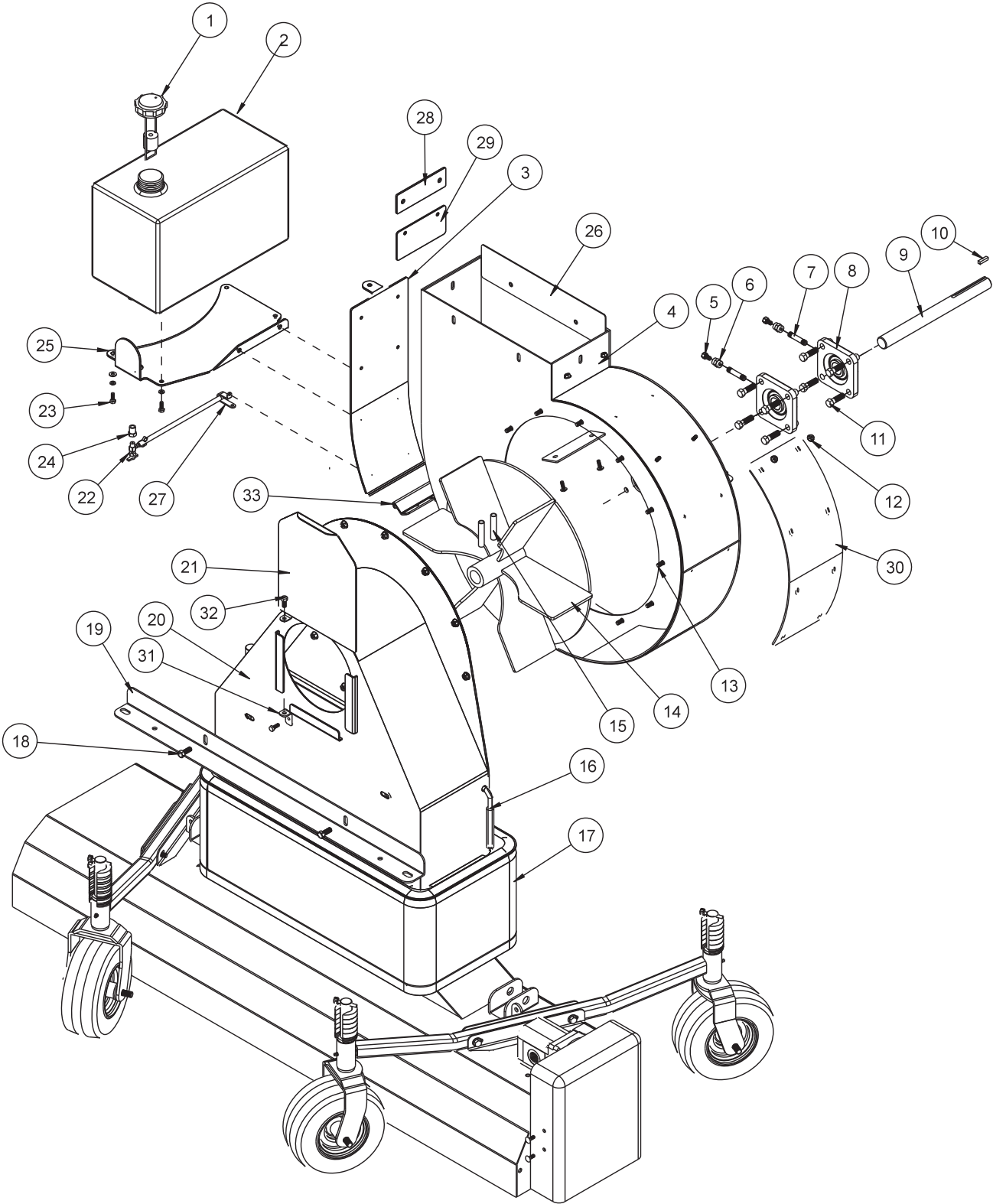

Parts

BLOWER AND VACUUM HOUSING PARTS LIST

REF#	PART#	DESCRIPTION	QUANTITY
1	15-492	Cap w/ Gauge	1
2	15-491	Gas Tank, 5 Gallon w/ Insert	1
3	78-439	Trap Door	1
	78-403	Trap Door Lining	1
4	78-375	Blower Housing	1
	78-436	Pipe Plug	1
	78-402	Blower Lining	1
	HWF-14-150	Fender Washer $\frac{1}{4}$ x $1\frac{1}{2}$	26
5	18-338	Male Connector	2
6	18-269	Coupling $\frac{1}{8}$	2
7	18-027	Nipple $\frac{1}{8}$ x 2	2
8	78-223	Mounted Bearing ($1\frac{1}{8}$ " Bore)	2
9	78-336	Vacuum Housing Shaft	1
10	HKSQ-14-100	Machine Key $\frac{1}{4}$ x $\frac{1}{4}$ x 1	1
11	HB-716-14-150	Bolt $\frac{7}{16}$ - 14 x $1\frac{1}{2}$	8
	HNTL-716-14	Lock Nut $\frac{7}{16}$ - 14	8
12	HSTP-14-20-075	Phillips Truss Head Machine Screw $\frac{1}{4}$ - 20 x $\frac{3}{4}$	18
	HSTP-14-20-100	Phillips Truss Head Machine Screw $\frac{1}{4}$ - 20 x 1	12
	HNTL-14-20	Top Lock Nut $\frac{1}{4}$ - 20	30
13	HBFL-516-18-075	Flange Bolt $\frac{5}{16}$ - 18 x $\frac{3}{4}$	11
	HNTL-516-18	Top Lock Nut $\frac{5}{16}$ - 18	11
14	78-301	Balanced Fan	1
15	78-347	Spiral Spring Pin	2
16	25-120	Handle Grip	1
17	78-243	Sweeper Boot	1
18	HBFL-38-16-075	Flange Bolt $\frac{3}{8}$ - 16 x $\frac{3}{4}$	2
	HNFL-38-16	Flange Whiz Lock Nut $\frac{3}{8}$ - 16	2
19	78-276	Vacuum Housing Support	1
20	78-257	Vacuum Housing	1
	8803-80	Trim Black	1
21	78-293	Cover Plate	1
22	15-039	Fuel Valve	1
	8800-60	Fuel Hose $\frac{1}{4}$ x 60"	1
	18-186	Hose Clamp	1
23	HB-14-20-075	Bolt $\frac{1}{4}$ - 20 x $\frac{3}{4}$	4
	HWL-14	Lockwasher $\frac{1}{4}$	4
	HW-14	Washer $\frac{1}{4}$	4
24	18-042	Reducer Bushing	1
25	78-378	Gas Tank Mount	1
	HB-516-18-075	Bolt $\frac{5}{16}$ - 18 x $\frac{3}{4}$	2
	HNFL-516-18	Flange Whiz Lock Nut $\frac{5}{16}$ - 18	2
26	78-355	Splice	1
27	HLC-100	Loom Clamp 1"	1
28	78-419	Bottom Lining Holder	1
29	78-411	Top Lining Holder	1
30	78-412	Wear Cover	1
31	78-433	Cover Plate Bolt Tab	1
	HB-14-20-075	Bolt $\frac{1}{4}$ - 20 x $\frac{3}{4}$	1
	HNTL-14-20	Lock Nut $\frac{1}{4}$ - 20	1
32	HB-516-18-075	Bolt $\frac{5}{16}$ - 18 x $\frac{3}{4}$	1
	HNTL-516-18	Lock Nut $\frac{5}{16}$ - 18	1
33	78-440	Door Pivot	1

FINGER REEL DRAWING

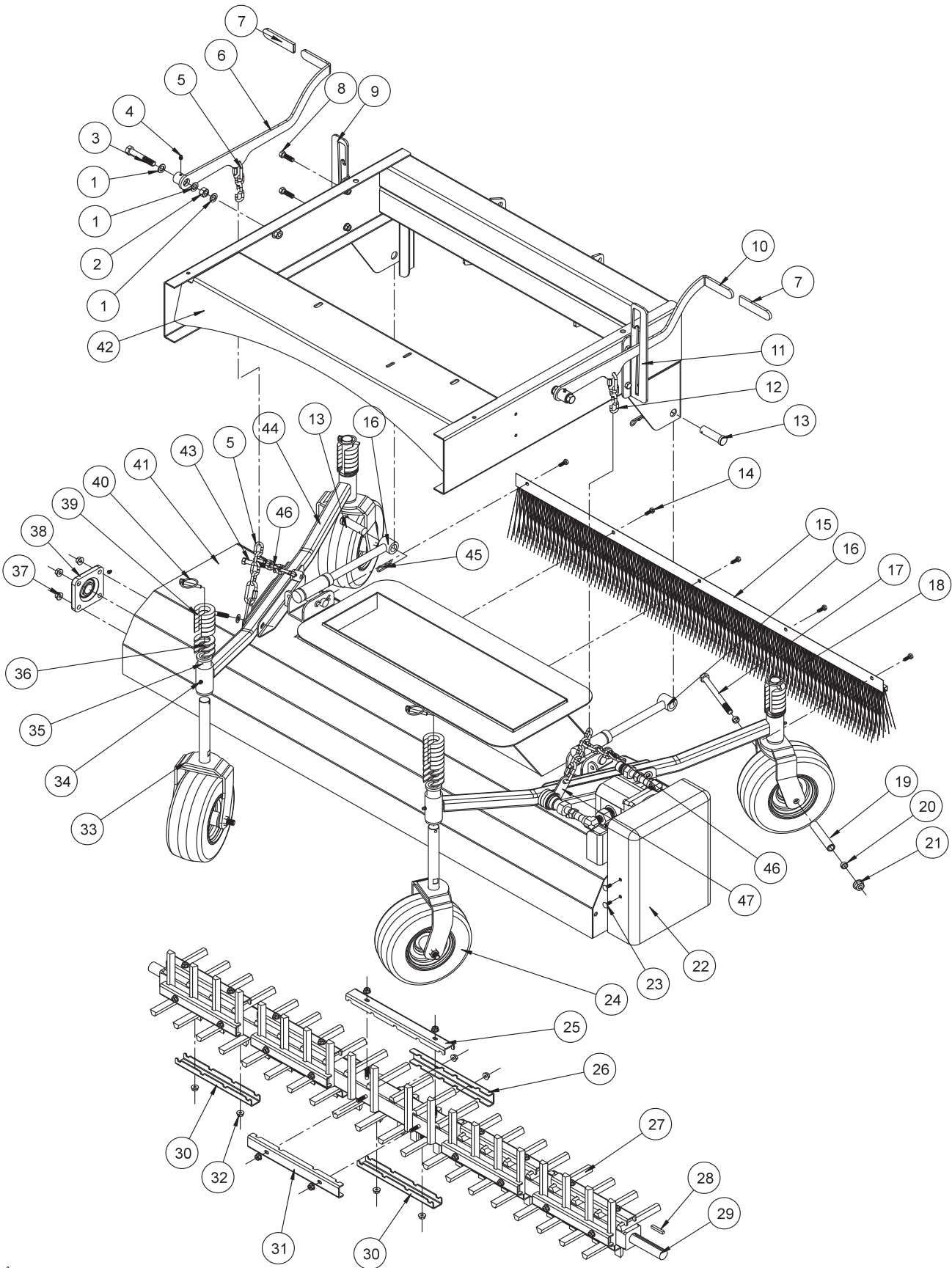

Parts

FINGER REEL PARTS LIST

REF#	PART#	DESCRIPTION	QUANTITY
1	HMB-58-14	Machine Bushing $\frac{5}{8}$ x 14GA	6
2	HN-58-11	Nut $\frac{5}{8}$ - 11	2
3	HB-58-11-300	Bolt $\frac{5}{8}$ - 11 x 3	2
	HNTL-58-11	Lock Nut $\frac{5}{8}$ - 11	2
4	HG-14-28-180	Grease Fitting $\frac{1}{4}$ - 28 x 180°	2
5	78-241	Chain Connector	8
6	78-284	Left Hand Deck Lift	1
	20-018	Bushing (part of 78-284)	1
7	15-020	Hand Grip	2
8	HB-38-16-125	Bolt $\frac{3}{8}$ - 16 x 1 $\frac{1}{4}$	4
	HNFL-38-16	Flange Whiz Lock Nut $\frac{3}{8}$ - 16	4
9	78-286	Left Hand Lift Arm Latch	1
10	78-283	Right hand Deck Lift	1
	20-018	Bushing (part of 78-283)	1
11	78-285	Right Hand Lift arm Latch	1
12	8820-8	Machine Chain Straight Link	2
13	HCP-34-250	Clevis Pin $\frac{3}{4}$ x 2 $\frac{1}{2}$	4
14	HB-14-20-075	Bolt $\frac{1}{4}$ - 20 x $\frac{3}{4}$	5
	HNFL-14-20	Flange Whiz Lock Nut $\frac{1}{4}$ - 20	5
15	78-344	Strip Brush Holder (drilled)	1
16	78-271	Reel Lift Rod	2
17	HB-12-13-600	Bolt $\frac{1}{2}$ - 13 x 6	4
18	78-322	Strip Brush	1
19	42-213	Axle Bearing	4
20	42-212	Castor Wheel Bearing	8
	HMB-12-14	Machine Bushing $\frac{1}{2}$ x 14GA	8
21	HNTL-12-13	Lock Nut $\frac{1}{2}$ - 13	4
22	72-056	Plastic Belt Guard	1
23	HST-14-20-075	Truss Head Machine Screw $\frac{1}{4}$ - 20 x $\frac{3}{4}$	4
	HNFL-14-20	Flange Whiz Lock Nut $\frac{1}{4}$ - 20	4
24	42-202	Tire & Wheel	4
	42-202-01	Tire 9 x 3.5 x 4 Ply	4
	42-202-02	Wheel	4
25	78-287	Finger Clamp 13"	1
26	78-327	Finger Clamp 10.5"	1
27	8969-5.250	Sweeper Finger	81
28	HKSQ-14-100	Machine Key $\frac{1}{4}$ x $\frac{1}{4}$ x 1	1
29	78-303	Finger Reel Bar	1
30	78-297	Finger Clamp 10"	17
31	78-326	Finger Clamp 12"	1
32	HNFL-516-18	Flange Whiz Lock Nut $\frac{5}{16}$ - 18	42
33	78-434	Castor Fork	4
34	HG-14-28-180	Grease Fitting $\frac{1}{4}$ - 28 x 180° (part of 78-434)	2
35	18-223	Flange Bushing (part of 78-434)	4
36	72-136	Quick Spacer 10GA	12
37	HNFL-38-16	Flange Whiz Lock Nut $\frac{3}{8}$ - 16	4
	HB-38-16-125	Bolt $\frac{3}{8}$ - 16 x 1 $\frac{1}{4}$	4
38	78-222	Mounted Bearing (1" bore)	2
39	72-053	Quick Spacer	24
40	42-539	Lynch Pin $\frac{5}{16}$	4
41	78-401	Reel Housing	1
	8803-80	Trim Black	1
42	78-449	Main Frame	1
43	HB-38-16-225	Bolt $\frac{3}{8}$ - 16 x 2 $\frac{1}{4}$	4
	HW-38	Washer $\frac{3}{8}$	4
	HNFL-38-16	Flange Whiz Lock Nut $\frac{3}{8}$ - 16	4
44	78-393	Castor Arm	2
45	HHP-18	Bridge Pin $\frac{1}{8}$	4
46	8820-3	Machine Chain Straight Link	2
47	78-421	Chain Connector	4

BRUSH REEL PARTS LIST

REF#	PART#	DESCRIPTION	QUANTITY
1	HMB-58-14	Machine Bushing $\frac{5}{8}$ x 14GA	6
2	HN-58-11	Nut $\frac{5}{8}$ - 11	2
3	HB-58-11-300	Bolt $\frac{5}{8}$ - 11 x 3	2
	HNTL-58-11	Lock Nut $\frac{5}{8}$ - 11	2
4	HG-14-28-180	Grease Fitting $\frac{1}{4}$ - 28 x 180°	2
5	78-241	Chain Connector	8
6	78-284	Left Hand Deck Lift	1
	20-018	Bushing (part of 78-284)	1
7	15-020	Hand Grip	2
8	HB-38-16-125	Bolt $\frac{3}{8}$ - 16 x 1 $\frac{1}{4}$	4
	HNFL-38-16	Flange Whiz Lock Nut $\frac{3}{8}$ - 16	4
9	78-286	Left Hand Lift Arm Latch	1
10	78-283	Right hand Deck Lift	1
	20-018	Bushing (part of 78-283)	1
11	78-285	Right Hand Lift arm Latch	1
12	8820-8	Machine Chain Straight Link	2
13	HCP-34-250	Clevis Pin $\frac{3}{4}$ x 2 $\frac{1}{2}$	4
14	HHP-18	Bridge Pin $\frac{1}{8}$	4
15	HB-14-20-075	Bolt $\frac{1}{4}$ - 20 x $\frac{3}{4}$	5
	HNFL-14-20	Flange Whiz Lock Nut $\frac{1}{4}$ - 20	5
16	78-344	Strip Brush Holder (drilled)	1
17	78-271	Reel Lift Rod	2
18	HB-12-13-600	Bolt $\frac{1}{2}$ - 13 x 6	4
19	78-322	Strip Brush	1
20	42-213	Axle Bearing	4
21	42-212	Castor Wheel Spacer	8
	HMB-34-10	Machine Bushing $\frac{3}{4}$ x 10GA	8
22	HNTL-12-13	Lock Nut $\frac{1}{2}$ - 13	4
23	72-056	Plastic Belt Guard	1
24	HSTP-14-20-075	Truss Head Machine Screw $\frac{1}{4}$ - 20 x $\frac{3}{4}$	4
	HNFL-14-20	Flange Whiz Lock Nut $\frac{1}{4}$ - 20	4
25	HKSQ-14-100	Machine Key $\frac{1}{4}$ x $\frac{1}{4}$ x 1	2
26	78-348	Shaft Spiral Brush	1
27	78-321	Spiral Brush	1
28	42-202	Tire and Wheel	4
	42-202-01	Tire 9 x 3.5 x 4 Ply	4
	42-202-02	Wheel	4
29	78-434	Castor Fork	4
30	HG-14-28-180	Grease Fitting $\frac{1}{8}$ x 28 x 180° (part of 78-434)	2 per
31	18-223	Flange Bushing (part of 78-434)	4 per
32	72-136	Quick Spacer 10GA	12
33	HNFL-38-16	Flange Whiz Lock Nut $\frac{3}{8}$ - 16	4
	HB-38-16-125	Bolt $\frac{3}{8}$ - 16 x 1 $\frac{1}{4}$	4
34	78-222	Mounted Bearing (1" bore)	2
35	72-053	Quick SPacer $\frac{1}{2}$ "	24
36	42-539	Lynch Pin $\frac{5}{16}$	4
37	78-401	Reel Housing	1
	8803-80	Trim Black	1
38	HB-38-16-250	Bolt $\frac{3}{8}$ - 16 x 2 $\frac{1}{2}$	4
	HW-38	Washer $\frac{3}{8}$	4
	HNFL-38-16	Flange Whiz Lock Nut $\frac{3}{8}$ - 16	4
39	78-449	Main Frame	1
40	78-393	Castor Arm	2
41	8820-3	Machine Chain Straight Link	2
42	78-421	Chain Connector	4



REEL & HYDRAULIC PUMP DRAWING

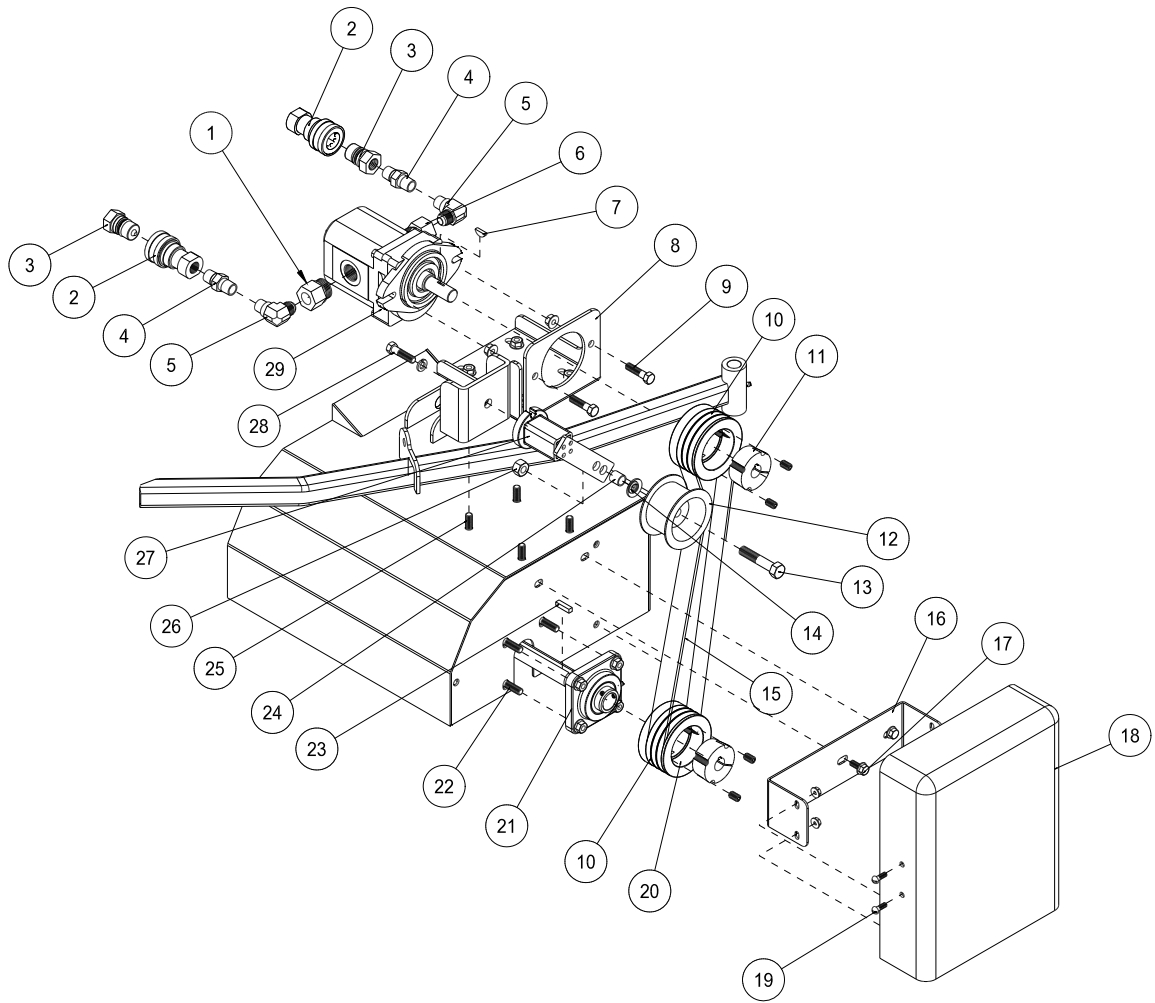

Parts

REEL & HYDRAULIC PUMP PARTS LIST

REF#	PART#	DESCRIPTION	QUANTITY
1	18-240	Pipe Adapter	1
2	78-228	Coupler 1/2"	2
3	78-229	Nipple 1/2"	2
4	18-334	Nipple	2
5	18-009	Elbow	2
6	18-333	Adapter	1
7	HWK-316-063	Woodruff key 3/16 x 5/8	1
8	78-259	Hydraulic Motor Mount	1
9	HB-38-16-150	Bolt 3/8 - 16 x 1 1/2	2
	HNFL-38-16	Flange Whiz Lock Nut 3/8 - 16	2
10	78-424	Pulley	2
11	78-428	Hub 3/4	1
	HSSHS-38-16-063	Set Screw 3/8 - 16 x 5/8 (part of 78-428)	2
12	16-013	Idler Pulley	1
13	HB-12-13-250	Bolt 1/2 - 13 x 2 1/2 (part of 78-224)	1
14	HMB-12-14	Machine Bushing 1/2 x 14GA	2
15	78-226	Belt, Single	3
16	72-058	Belt Guard Mount Bracket	1
17	HBFL-516-18-075	Flange Bolt 5/16 - 18 x 3/4	2
	HNFL-516-18	Flange Whiz Lock Nut 5/16 - 18	2
18	72-056	Plastic Belt Guard	1
19	HSTP-14-20-075	Truss Head Machine Screw 1/4 - 20 x 3/4	4
	78-274	Cage Nuts	4
20	78-429	Hub 1"	1
	HSSHS-38-16-063	Set Screw 3/8 - 16 x 5/8 (part of 78-429)	2
21	78-222	Mounted Bearing (1" bore)	2
22	HB-38-16-125	Bolt 3/8 - 16 x 1 1/4	8
	HNFL-38-16	Flange Whiz Lock Nut 3/8 - 16	8
23	HKSQ-14-100	Machine Key 1/4 x 1/4 x 1	1
24	76-275	Spacer (part of 78-224)	1
25	HB-38-16-100	Bolt 3/8 - 16 x 1	4
	HNFL-38-16	Flange Whiz Lock Nut 3/8 - 16	4
26	HNCL-12-13	Center Lock Nut 1/2 - 13 (part of 78-224)	1
27	78-224	Belt Tensioner	1
28	HBM-10-1.5-30	Metric Bolt 10-1.5 x 30 (part of 78-224)	1
	HWLM-10	Metric Lockwasher #10 (part of 78-224)	1
29*	78-414	Hydraulic Motor	1

* NO OTHER PARTS ARE REPLACEABLE FOR HYDRAULIC MOTOR.

HOPPER DRAWING

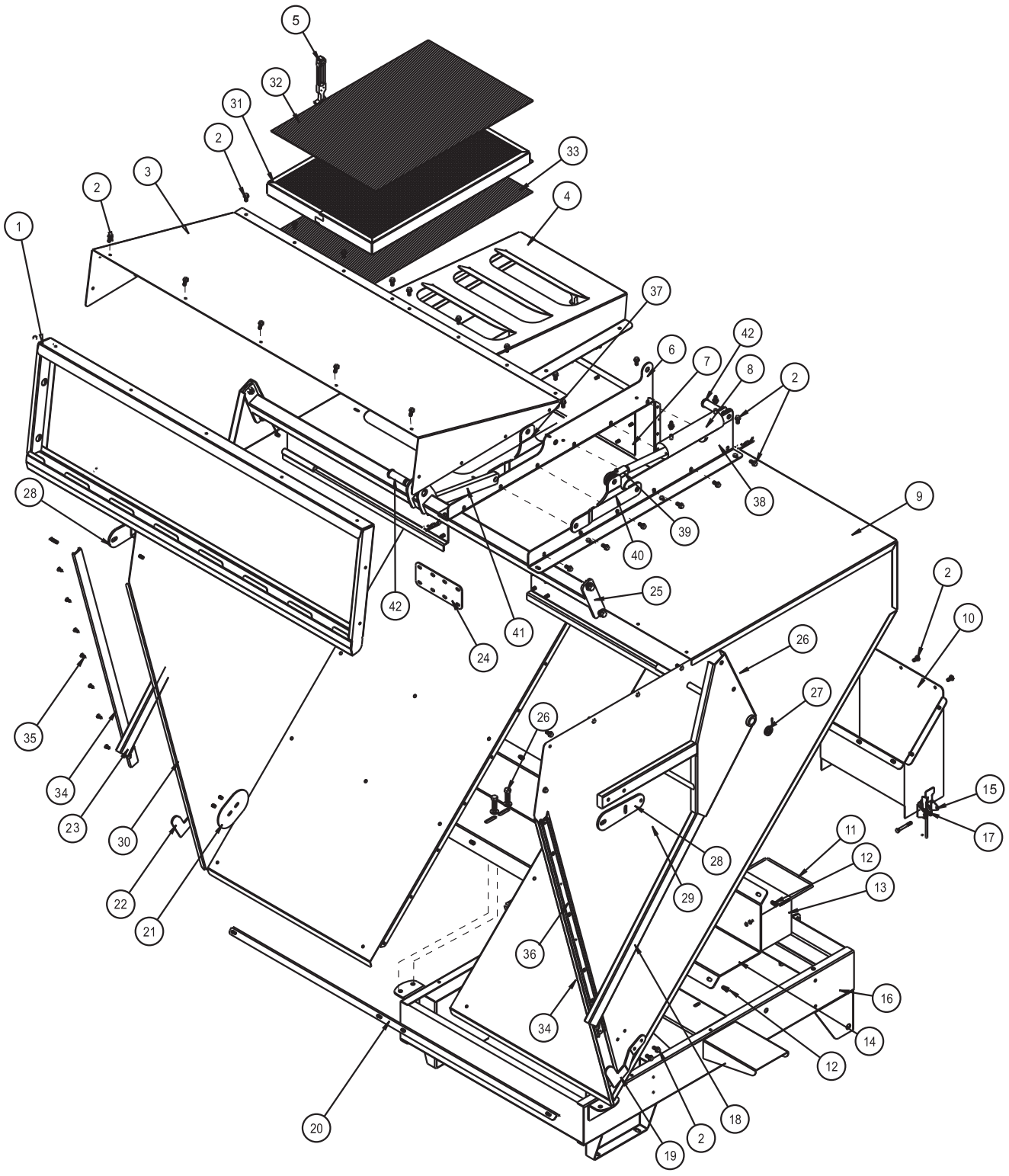

Parts

HOPPER PARTS LIST

REF#	PART#	DESCRIPTION	QUANTITY
1	78-305	Filter Insert	1
2	HBFL-516-18-075	Flange Bolt $\frac{5}{16}$ - 18 x $\frac{3}{4}$	72
	HNFL-516-18	Flange Whiz Lock Nut $\frac{5}{16}$ - 18	72
3	78-272	Hopper Cover	1
4	78-395	Filter Hood	1
	HB-14-20-125	Bolt $\frac{1}{4}$ - 20 x $1\frac{1}{4}$	6
	HNFL-14-20	Flange Whiz Lock Nut $\frac{1}{4}$ - 20	6
5	78-384	Flex Draw Latch	1
	HSM-8-32-150	Machine Screw #8 - 32 x $1\frac{1}{2}$	3
6	78-549	Left Cylinder Plate	1
7	78-345	Clear Lexan Window	1
	HSTP-14-20-075	Phillips Truss Head Machine Screw $\frac{1}{4}$ - 20 x $\frac{3}{4}$	12
	HNFL-14-20	Flange Whiz Lock Nut $\frac{1}{4}$ - 20	12
8	75-714	Hydraulic Cylinder	1
	18-169	Adapter	2
9	78-260	Right Hopper	1
10	78-262	Chute	1
11	78-304	Battery Hold Down	1
	HWL-14	Lockwasher $\frac{1}{4}$	2
	HN-14-20	Nut $\frac{1}{4}$ - 20	2
12	HBFL-516-18-075	Flange Bolt $\frac{5}{16}$ - 18 x $\frac{3}{4}$	12
	HNFL-516-18	Flange Whiz Lock Nut $\frac{5}{16}$ - 18	12
13	22-073	Battery (optional)	1
14	78-273	Hopper Mount	1
15	78-432	Latch Keeper	1
	HB-516-18-250	Bolt $\frac{5}{16}$ - 18 x $2\frac{1}{2}$	1
	HNTL-516-18	Lock Nut $\frac{5}{16}$ - 18	1
16	78-449	Main Frame	1
17	48-115	Adjustable Draw Latch	1
	HSTP-14-20-075	Phillips Truss Head Machine Screw $\frac{1}{4}$ - 20 x $\frac{3}{4}$	2
18	78-263	Right Door Arm	1
19	78-389	Right Hopper Door Latch	1
20	78-282	Hopper Strap	1
21	78-292	Door Latch Support	2
22	78-388	Left Hopper Door Latch	1
23	78-264	Left Door Arm	1
24	78-291	Connecting Plate	1
25	78-265	Cross Bar	1
26	HB-12-13-150	Bolt $\frac{1}{2}$ - 13 x $1\frac{1}{2}$	8
	HW-12	Washer $\frac{1}{2}$	8
	HNTL-12-13	Lock Nut $\frac{1}{2}$ - 13	8

(Continued on next page)

HOPPER DRAWING

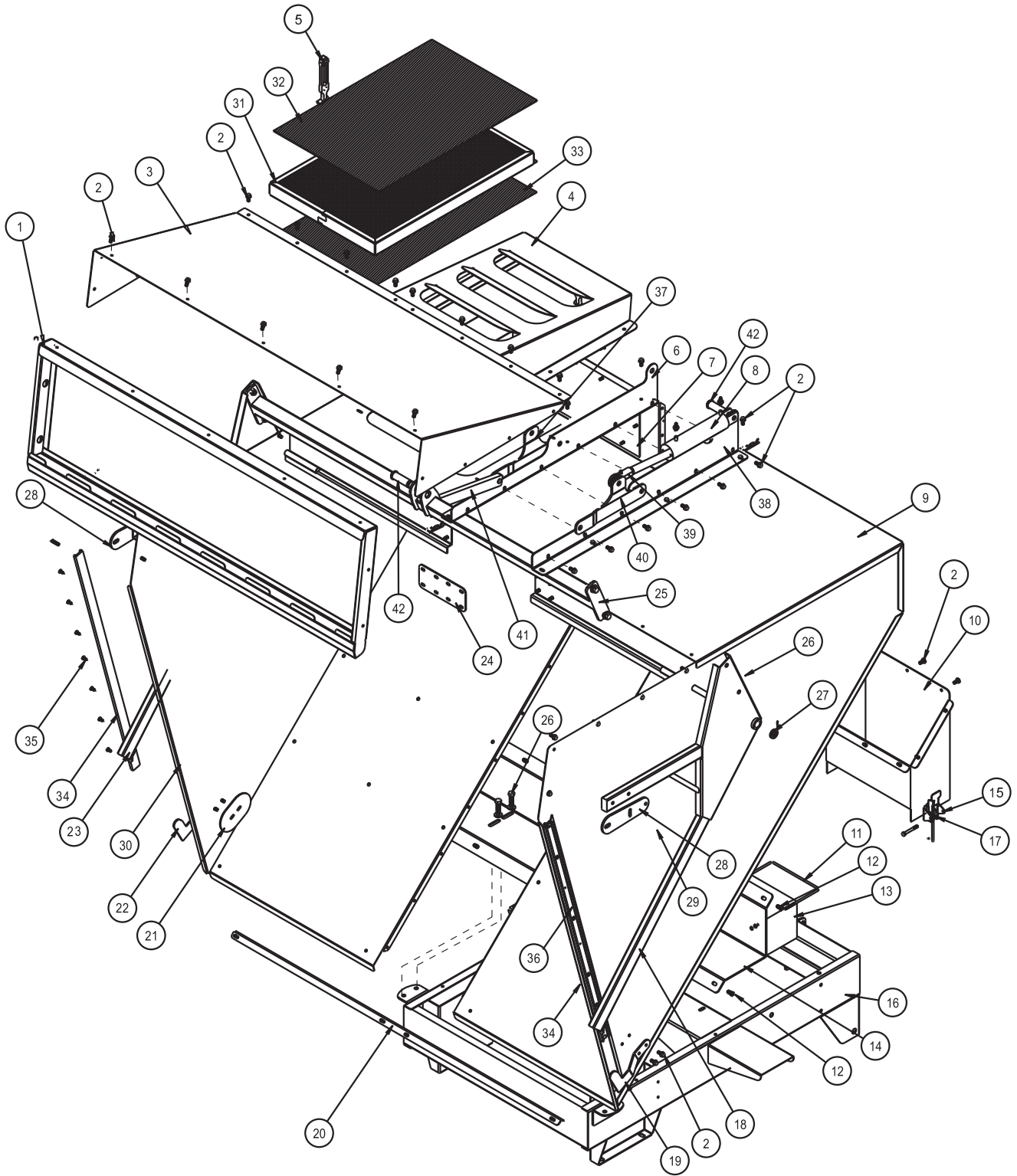

Parts

HOPPER PARTS LIST

REF#	PART#	DESCRIPTION	QUANTITY
27	HMB-34-10	Machine Bushing $\frac{3}{4}$ x 10GA	4
	HP-18-150	Cotter Pin $\frac{1}{8}$ x $1\frac{1}{2}$	2
28	78-319	Tailgate Adjustment	2
29	HB-38-16-175	Bolt $\frac{3}{8}$ - 16 x $1\frac{3}{4}$	4
	HNFL-38-16	Flange Whiz Lock Nut $\frac{3}{8}$ -16	4
30	78-383	Left Hopper	1
31	78-394	Filter Case	1
32	78-386	Hopper Filter	1
33	78-382	Screen	1
34	78-385	Wear Strip Bracket	2
	8946-42	Wear Strip 42"	2
35	HSD-8-050	Pan Head Drill Screw #8 x $\frac{1}{2}$	14
36	HSM-10-32-100	Machine Screw #10 -32 x 1	2
	HWL-10	Lockwasher #10	2
	HN-10-32	Nut #10 - 32	2
37	78-547	Left Cylinder Arm	1
38	78-548	Right Cylinder Plate	1
39	18-154	Rod End	1
40	78-546	Right CYlinder Arm	1
41	78-550	Crossbar Link Arm	1
42	HCP-58-175	Clevis Pin $\frac{5}{8}$ x $1\frac{3}{4}$	2
	HHP-18-100	Bridge Pin $\frac{1}{8}$ x 1	2
NS	8979-61	Weather Stripping	2

78-415 2-BANK VALVE DRAWING

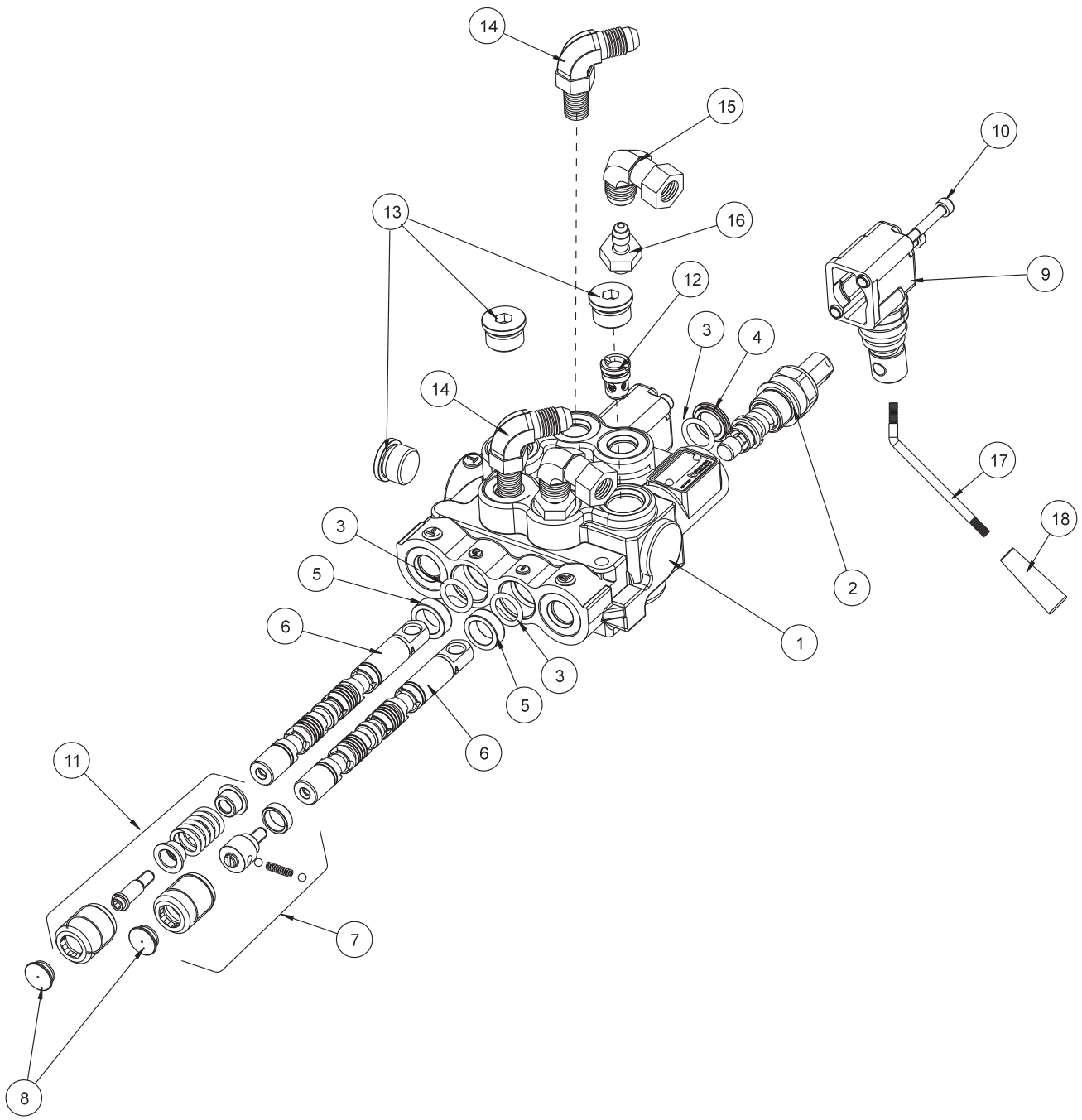

Parts

78-415 2-BANK VALVE PARTSLIST

REF#	PART#	DESCRIPTION	QUANTITY
1*	78-415-01	Body (complete with spacer and check valve)	1
2*	78-415-02	Spool HDM10	1
3*	78-415-03	O-Ring Seal	6
4*	78-415-04	Flanged Washer HDM10	3
5*	78-415-05	Spacer	3
6*	78-415-06	A Type Spool HDS11	3
7*	78-415-07	Positioner	2
8*	78-415-08	Plug	3
9*	78-415-09	Lever Group HDS11	3
10*	78-415-10	Metric Socket Screw M5 x .8 x 45	6
11*	78-415-11	Positioner	1
12*	78-415-12	Check Valve Assembly HDM12	1
13*	78-415-13	³ / ₄ - 16 SAE 8 Screw Plug	3
14	18-168	Elbow 3/8 Straight Thread	2
15	18-202	Elbow	2
16	18-169	Adapter SAE 3/8	4
17	78-418	Bent Handle	2
18		Tapered Knob	3
* 78-415		2 – Bank Hydraulic Valve (includes all * items)	

REAR AXLE / ELECTRIC BRAKE PARTS LIST

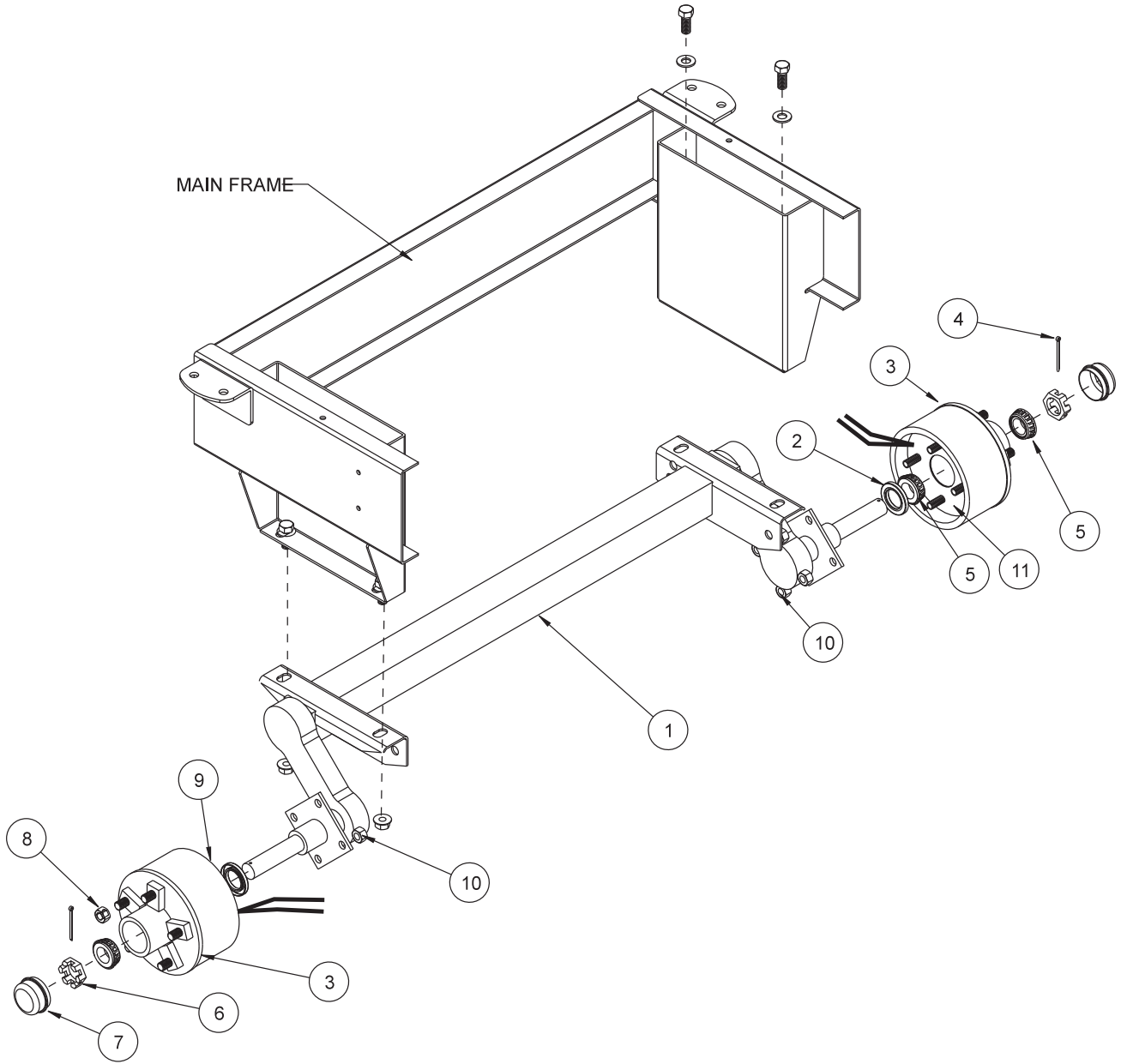

Parts

REAR AXLE / ELECTRIC BRAKE PARTS LIST

REF#	PART#	DESCRIPTION	QUANTITY
1	78-216	Axle Complete	1
2	78-216-02	Grease Seal	2
3	78-406	Hub Assembly (includes all * items)	2
4	HP-18-200	Cotter Pin $\frac{1}{8}$ x 2	2
5*	78-119	Bearing Cup and Cone	2
6	HNAR-100-14	Slotted Jam Nut 1 - 14	2
7*	80-167	Grease Cap	2
8	HNL-12-20	Lug Nut $\frac{1}{2}$ - 20	10
9	78-409	RH Brake Assembly	1
10	HN-716-20	Nut $\frac{7}{16}$ - 20	8
	HWL-716	Lockwasher $\frac{7}{16}$	8
11	78-408	LH Brake Assembly	1
	78-410	Wire Harness	1

INSTALLATION INSTRUCTIONS

1. Block rear of machine up. Remove the rear tires and rear hubs. All parts except hubs to be reused.
2. There is a right and left brake (Ref 9 & 11). Place the brake on the axle and bolt to axle using the $\frac{7}{16}$ - 20 nuts and lockwashers (Ref 10).
3. Then place the hub and drum assembly (Ref 3) over the brake. Be sure to install the grease seal (Ref 2) and the bearing cup and cone (Ref 5) as shown in the drawing.
4. Put tires back on and hold in place with the $\frac{1}{2}$ -20 lug nuts (Ref 8). Put slotted jam nut (Ref 6), cotter pin (Ref 4) and dust cap (Ref 7) on axle end.
5. Check all nuts and be sure they are tight.
6. Take the wire harness and hook the female space connectors to the male spade connectors on the brake assemblies. Run wire harness up side of main frame to front of machine. Hold wire harness in place with the tie straps.
7. Dealer must provide the connector that hooks to the tow unit. Place one side of connector onto wire harness, connect the other half to the tow unit.
8. Check all connections and hardware. Test brakes before putting machine into service.

NOTE:

This unit is not intended for highway use.

78-201 REPLACEMENT BRUSH REEL DRAWING

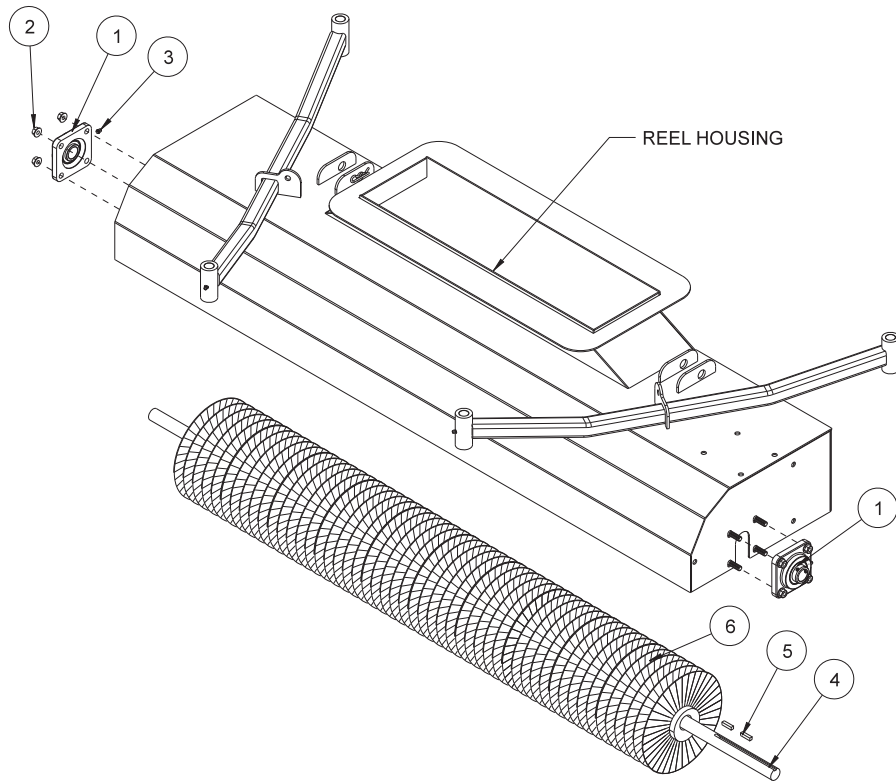

78-202 REPLACEMENT FINGER REEL DRAWING

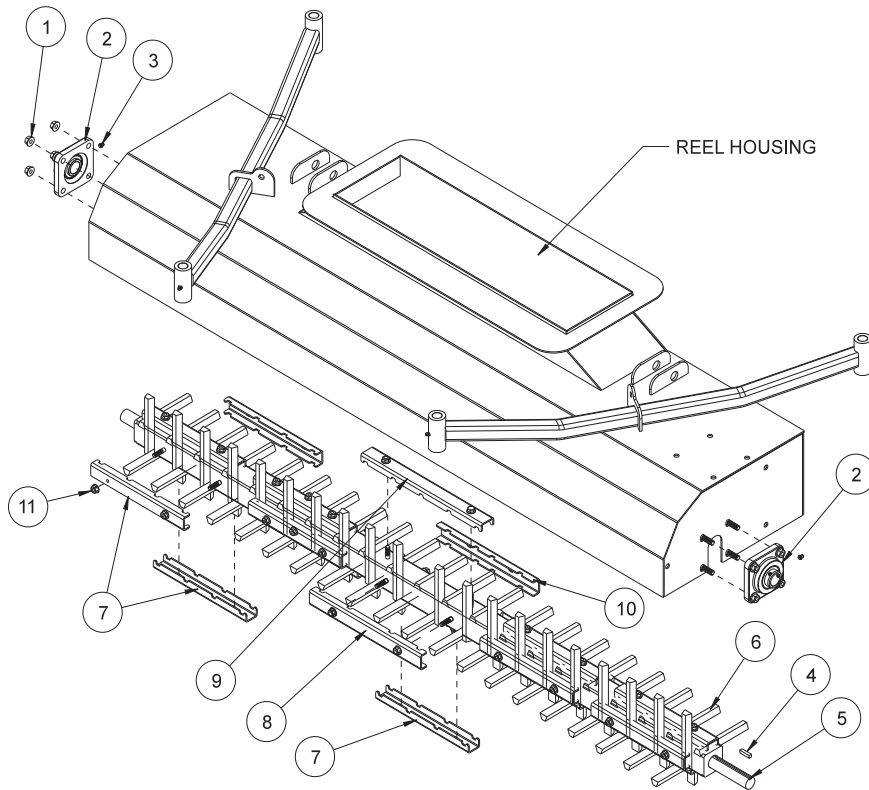

Accessories

78-201 REPLACEMENT BRUSH REEL PARTS LIST

REF#	PART#	DESCRIPTION	QUANTITY
1	78-222	Mounted Bearing	2
2	HB-38-16-125	Bolt $\frac{3}{8}$ - 16 x $1\frac{1}{4}$	8
	HNFL-38-16	Flange Whiz Lock Nut $\frac{3}{8}$ - 16	8
3	HG-14-28-180	Grease Fitting $\frac{1}{4}$ -20 x 180° (comes with 78-222)	2
4	78-348	Spiral Brush Shaft	1
5	HKSQ-14-100	Machine Key $\frac{1}{4}$ x $\frac{1}{4}$ x 1	2
6	78-321	Spiral Brush	1

78-202 REPLACEMENT FINGER REEL PARTS LIST

REF#	PART#	DESCRIPTION	QUANTITY
1	HB-38-16-125	Bolt $\frac{3}{8}$ - 16 x $1\frac{1}{4}$	8
	HNFL-38-16	Flange Whiz Lock Nut $\frac{3}{8}$ - 16	8
2	78-222	Mounted Bearing	2
3	HG-14-28-180	Grease Fitting $\frac{1}{4}$ -20 x 180° (comes with 78-222)	2
4	HKSQ-14-100	Machine Key $\frac{1}{4}$ x $\frac{1}{4}$ x 1	1
5	78-303	Finger Reel Bar	1
6	8969-5.250	Sweeper Finger	81
7	78-297	Finger Clamp 10"	17
8	78-326	Finger Clamp 12"	1
9	78-287	Finger Clamp 13"	1
10	78-327	Finger Clamp 10.5"	1
11	HNFL-516-18	Flange Whiz Lock Nut $\frac{5}{16}$ - 18	40

78-205 REMOTE VACUUM HOSE DRAWING

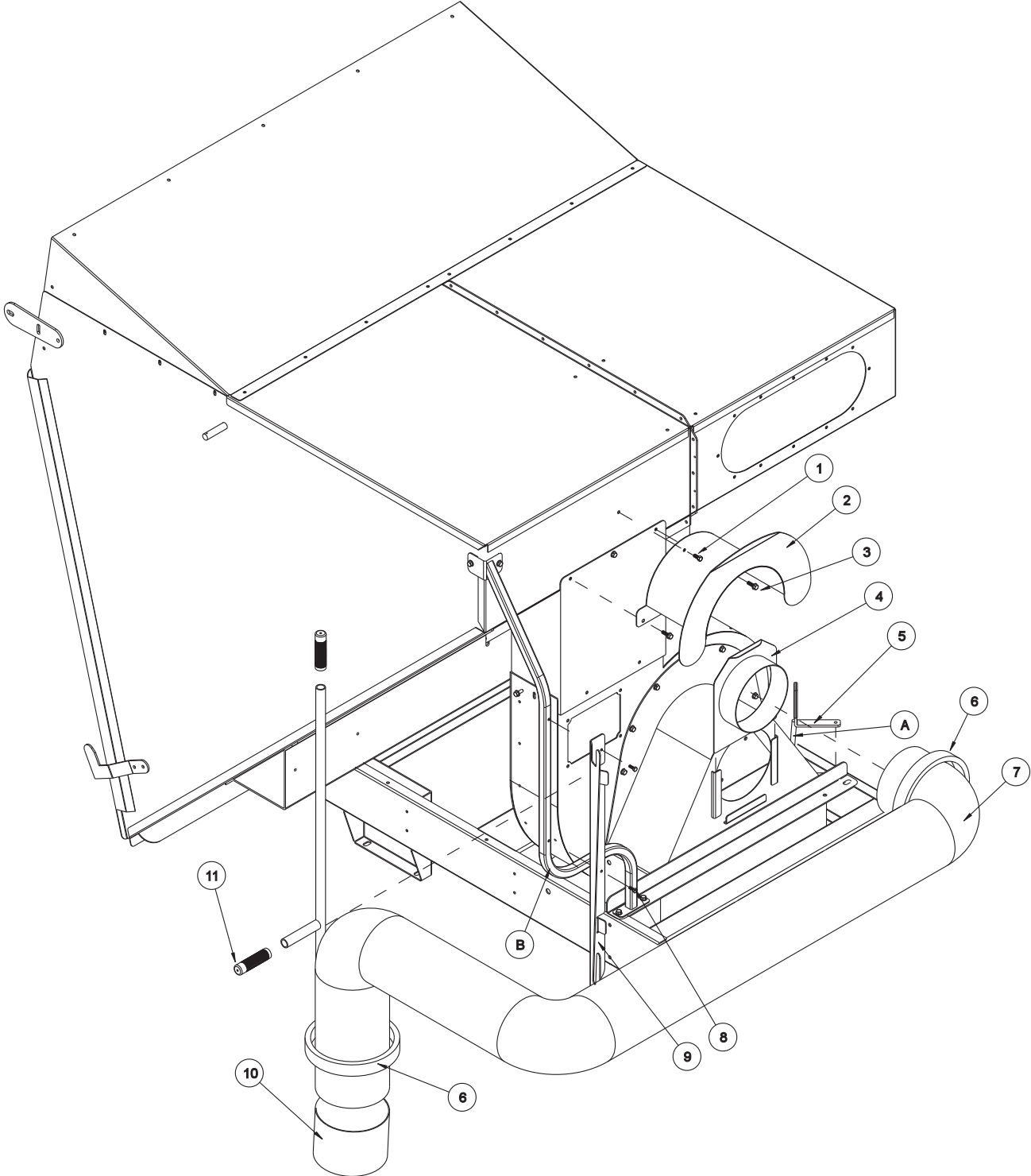

Accessories

78-205 REMOTE VACUUM HOSE PARTS LIST

REF#	PART#	DESCRIPTION	QUANTITY
1	HBFL-516-18-075	Flange Bolt $\frac{5}{16}$ - 18 x $\frac{3}{4}$	1
	HNFL-516-18	Flange Whiz Lock Nut $\frac{5}{16}$ - 18	1
2	78-318	Hose Rack	1
3	HBFL-516-18-075	Flange Bolt $\frac{5}{16}$ - 18 x $\frac{3}{4}$ (part of machine)	2
	HNFL-516-18	Flange Whiz Lock Nut $\frac{5}{16}$ - 18 (part of machine)	2
4	78-314	Remote Hose Connector	1
5	78-311	Handle Stop (part of machine)	1
6	18-340	Hose Clamp	2
7	8970-150	Vacuum Hose 8" x 150"	1
8	HB-14-20-150	Bolt $\frac{1}{4}$ - 20 x $1\frac{1}{2}$	2
	HNTL-14-20	Lock Nut $\frac{1}{4}$ -20	2
9	78-350	Handle Holder	1
	8803-17	Trim	1
10	78-354	Hose Handle	1
11	15-019	Round Grip	2

INSTALLATION INSTRUCTIONS

You will need two people and the tailgate open with an empty hopper. One person will have to be inside hopper. Be sure engine is off. You will need an $\frac{11}{32}$ and $\frac{9}{32}$ drill.

1. Remove the two bolts (Ref 3) from the chute. Bolt the hose rack (Ref 2) in place using the two bolts you removed from the chute. Using an $\frac{11}{32}$ drill, drill through the hopper using the hose rack as a guide. Use the $\frac{5}{16}$ - 18 x $\frac{3}{4}$ bolt and lock nut (Ref 1). The nut should be on the inside of the hopper. The person in the hopper can get out now.
2. Center the handle holder (Ref 9) between the bends on the brush guard (Ref B) with the handle holder flush on the inside of the brush guard. Mark the two holes and drill through the brush guard with a $\frac{9}{32}$ drill. Use the two $\frac{1}{4}$ - 20 x $1\frac{1}{2}$ bolts and lock nuts (Ref 8) to bolt handle holder to the brush guard. Cut and put trim into the two notches that hold the hose handle.
3. Connect the hose to the hose handle (Ref 10) with the hose on the same side as the long handle. Then put other end of hose to remote hose connector (Ref 4). Use the two hose clamps (Ref 6) to hold hose in place.
4. Remove cover plate from in front of the vacuum housing and place in pocket on chute. Place the remote hose connector into the pocket that the cover plate came out of. The cover plate and the remote hose connector must be switched depending which operation you are doing.
5. For storage, loop the vacuum hose over the hose rack (Ref 2) and place the hose handle (Ref 10) into the handle holder (Ref 9).
6. When you are going to operate the vacuum, pull handle stop (Ref 5) towards the front of machine and lift up handle (Ref A). While holding handle (Ref A) up, push handle stop (Ref 5) back so that it holds the handle (Ref A) up.
7. You may want to remove the hose handle, hose and remote hose connector if you are not going to use the vacuum for an extended amount of time.



78-204 5TH WHEEL HITCH DRAWING

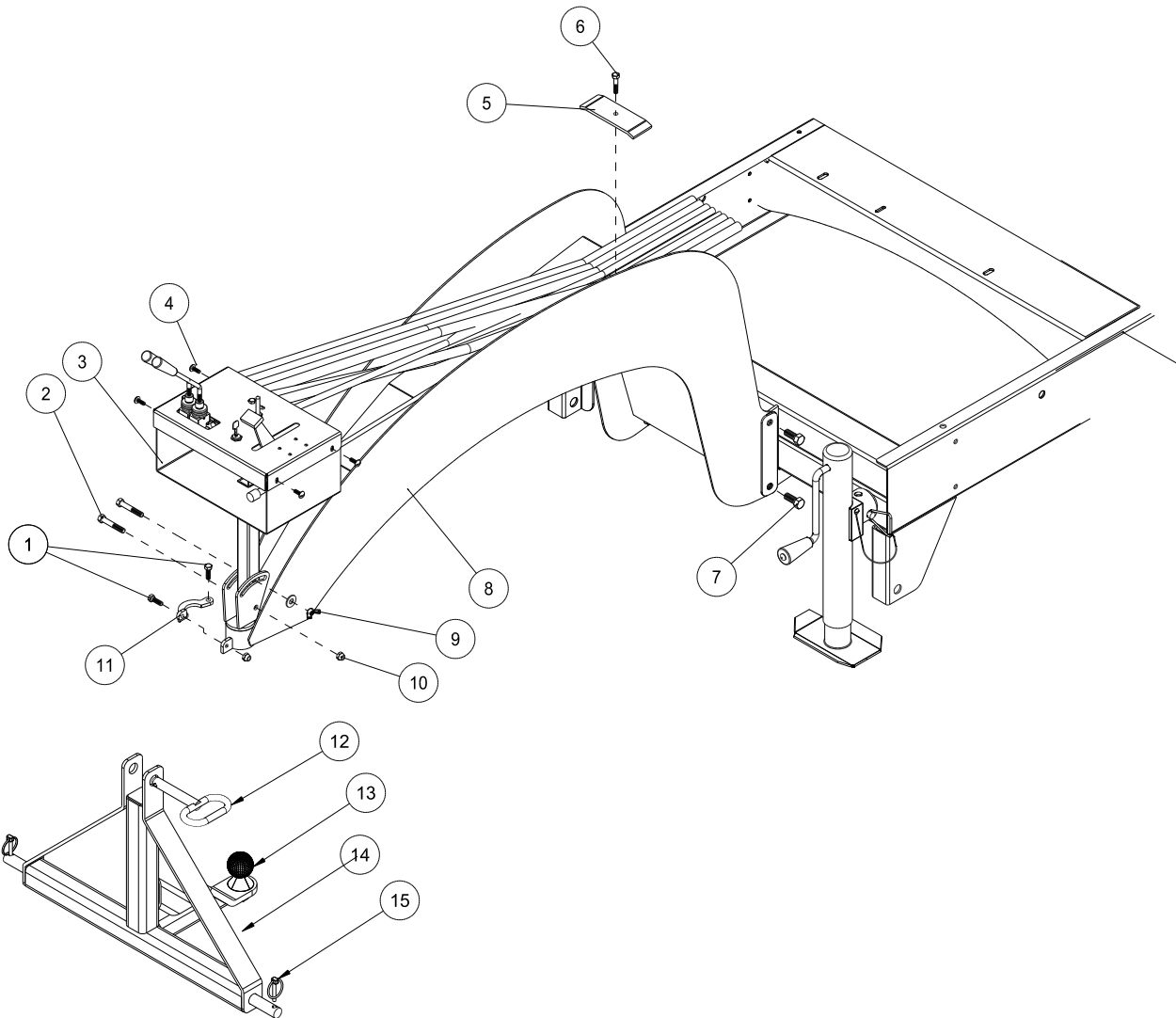

Accessories



Do not tow on public roads.

78-204 5TH WHEEL HITCH PARTS LIST

REF#	PART#	DESCRIPTION	QUANTITY
1	HB-516-18-100	Bolt $\frac{5}{16}$ - 18 x 1	2
	HNTL-516-18	Lock Nut $\frac{5}{16}$ - 18	2
2	HB-38-16-225	Bolt $\frac{3}{8}$ - 16 x 2 $\frac{1}{4}$	2
3	78-352	Control Panel Mount	1
4	HST-14-20-075	Truss Head Machine Screw $\frac{1}{4}$ - 20 x $\frac{3}{4}$ (part of machine)	4
	HNFL-14-20	Flange Whiz Lock Nut $\frac{1}{4}$ - 20 (part of machine)	4
5	78-353	Hose Hold Down	1
6	HB-516-18-150	Bolt $\frac{5}{16}$ - 18 x 1 $\frac{1}{2}$	1
	HNTL-516-18	Lock Nut $\frac{5}{16}$ - 18	1
7	HB-12-13-125	Bolt $\frac{1}{2}$ - 13 x 1 $\frac{1}{4}$	4
	HNTL-12-13	Lock Nut $\frac{1}{2}$ - 13	4
8	78-391	Gooseneck	1
9	HNW-38-16	Wing Nut $\frac{3}{8}$ - 16	1
	HW-38	Washer $\frac{3}{8}$	1
10	HNTL-38-16	Lock Nut $\frac{3}{8}$ - 16	1
11	78-390	Ball Lock Arm	1
12*	7-029	Hitch Pin	1
13*	18-371	2" Ball	1
14*	73-039	3-Point hitch	1
15*	42-539	Lynch Pin	2
*	73-007	3-Point Add On Kit (optional to mount to a Tractor)	1

INSTALLATION INSTRUCTIONS

Use two people to install hitches.

1. Block both wheels so machine does not roll.
2. Use the jack that is part of the sweeper to raise or lower sweeper to comfortable working height.
3. Slide the gooseneck (Ref 8) over the tabs on the front of the sweeper frame. Hitch must be on the outside. Use the four $\frac{1}{2}$ - 13 x 1 $\frac{1}{4}$ bolts (Ref 7) on the outside and four lock nuts on the inside. Tighten all four bolts.
4. Install the control panel mount (Ref 3) on the front of the gooseneck (Ref 8) as shown, using two $\frac{3}{8}$ - 16 x 2 $\frac{1}{4}$ bolts (Ref 2). On the bottom bolt use lock nut (Ref 9) and just tighten snug. On the top bolt use the $\frac{3}{8}$ washer and wing nut (Ref 10). Tighten both after adjusting for the proper position.
5. The control panel has all hose, wiring and throttle cable connected to it and the sweeper. The control panel is wrapped and fastened to the front of the sweeper.
6. Remove the control panel from the sweeper, bring it forward with the hoses to the rear and the throttle on the left hand side.
7. Fasten the control panel to the control panel mount with the four truss head machine screws $\frac{1}{4}$ - 20 x $\frac{3}{4}$ (Ref 4) and four flange whiz lock nuts $\frac{1}{4}$ - 20.
8. Put the two handles onto the valve and tighten the lock nuts with the handles pointing forward.
9. Lay the hoses, wiring and throttle cable on top of the gooseneck and place the hose hold-down (Ref 5) over the top. At the rear most hole on top of the gooseneck fasten the hose hold-down with $\frac{5}{16}$ - 18 x 1 $\frac{1}{2}$ bolt and lock nut (Ref 6).



Do not tow on public roads.

78-206 CLEVIS HITCH DRAWING

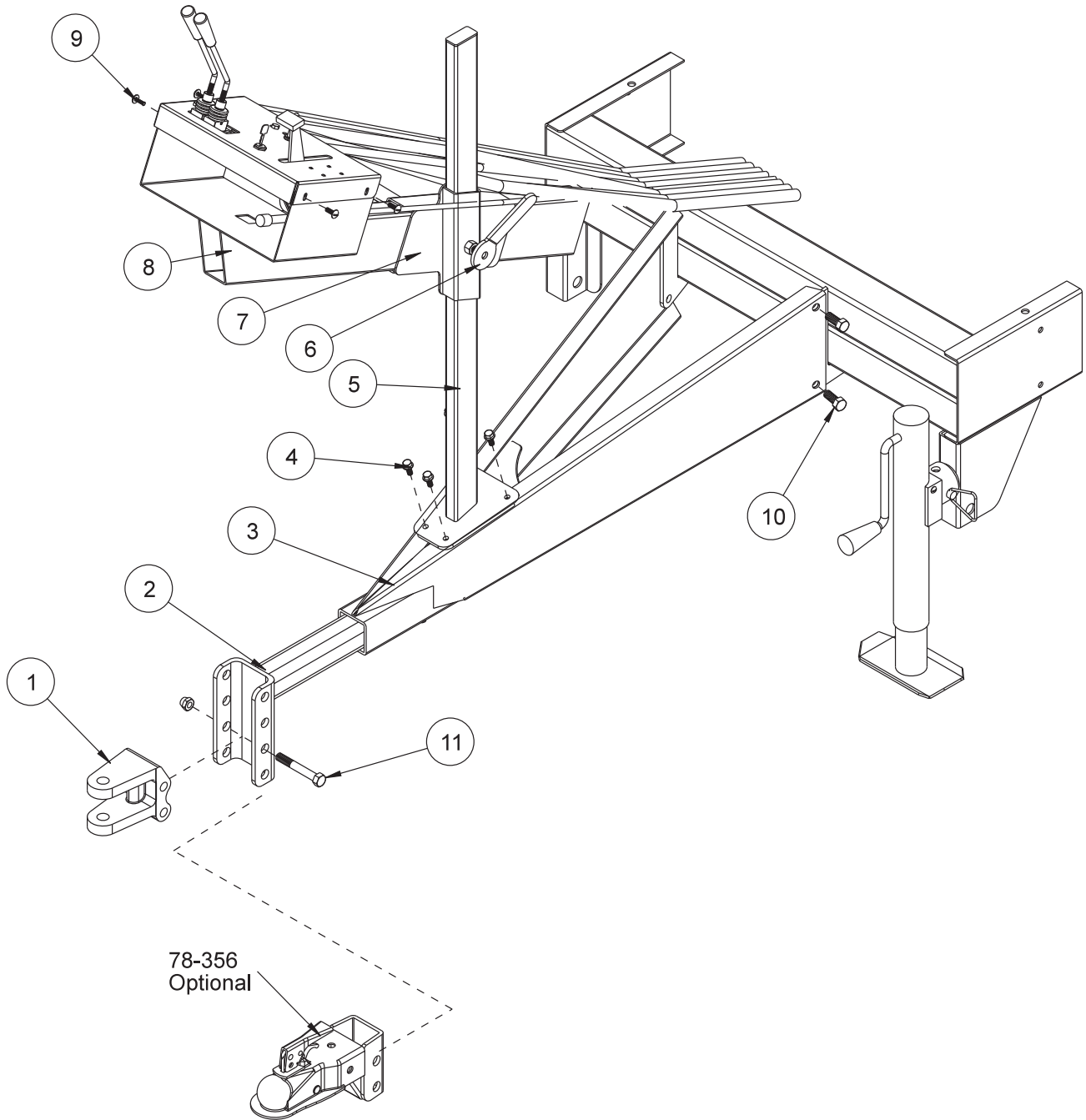

Accessories

78-206 CLEVIS HITCH PARTS LIST

REF#	PART#	DESCRIPTION	QUANTITY
1	78-244	3/4" Clevis	1
2	78-268	Hitch Insert	1
3	78-267	Tongue	1
	HB-12-13-350	Bolt 1/2 - 13 x 3 1/2	1
	HNTL-12-13	Lock Nut 1/2 - 13	1
4	HBFL-516-18-075	Flange Bolt 5/16 - 18 x 3/4	4
	HNFL-516-18	Flange Whiz Lock Nut 5/16 - 18	4
5	78-299	Adjustment Slide	1
6	78-295	Adjustment Lock	2
	15-020	Hand Grip	2
7	78-298	Control Panel Adjustment	1
8	78-312	Control Panel Mount	1
9	HSTP-14-20-075	Phillips Truss Machine Screw 1/4 - 20 x 3/4 (part of machine)	4
	HNFL-14-20	Flange Whiz Lock Nut 1/4 - 20 (part of machine)	4
10	HB-12-13-125	Bolt 1/2 - 13 x 1 1/4	4
	HNTL-12-13	Lock Nut 1/2 - 13	4
11	HB-58-11-450	Bolt 5/8 - 11 x 4 1/2 (part of 78-244)	2
	HNCL-58-11	Center Lock Nut 5/8 - 11 (part of 78-244)	2

INSTALLATION INSTRUCTIONS

Use two people to install hitches.

1. Block both wheels so machine does not roll.
2. Use the jack that is part of the sweeper to raise or lower sweeper to comfortable working height.
3. Slide the tongue (Ref 3) over the tabs on the front of the sweeper frame. Hitch must be on the outside. Use the four 1/2 - 13 x 1 1/4 bolts (Ref 10) on the outside and four lock nuts on the inside. Tighten all four bolts.
4. Install adjustment slide (Ref 5) to tongue (Ref 3) using the four flange bolts 1/4 - 20 x 3/4 and four flange whiz lock nuts 1/4 - 20 (Ref 4).
5. Loosen adjustment locks (Ref 6) on control panel adjustment (Ref 7) and put control panel adjustment onto the adjustment slide.
6. Tighten one adjustment lock (Ref 6).
7. Slide the control panel mount (Ref 8) through the control panel adjustment (Ref 7) and tighten the other adjustment lock (Ref 6).
8. The control panel has all the hoses, wiring and throttle cable connected to it and to the sweeper. The control panel is wrapped and fastened to the front of the sweeper.
9. Remove the control panel from the sweeper, bring it forward with the hoses to the rear and the throttle on the left hand side.
10. Fasten the control panel to the control panel mount with the four truss head machine screws 1/4 - 20 x 3/4 and four flange whiz lock nuts 1/4 - 20 (Ref 9).
11. Put the two handles onto the valve and tighten the lock nuts with the handles pointing forward.
12. Place three hoses and the throttle cable on the left hand side of the adjustment slide.



CAUTION Do not tow on public roads.



78-209 BALL HITCH DRAWING

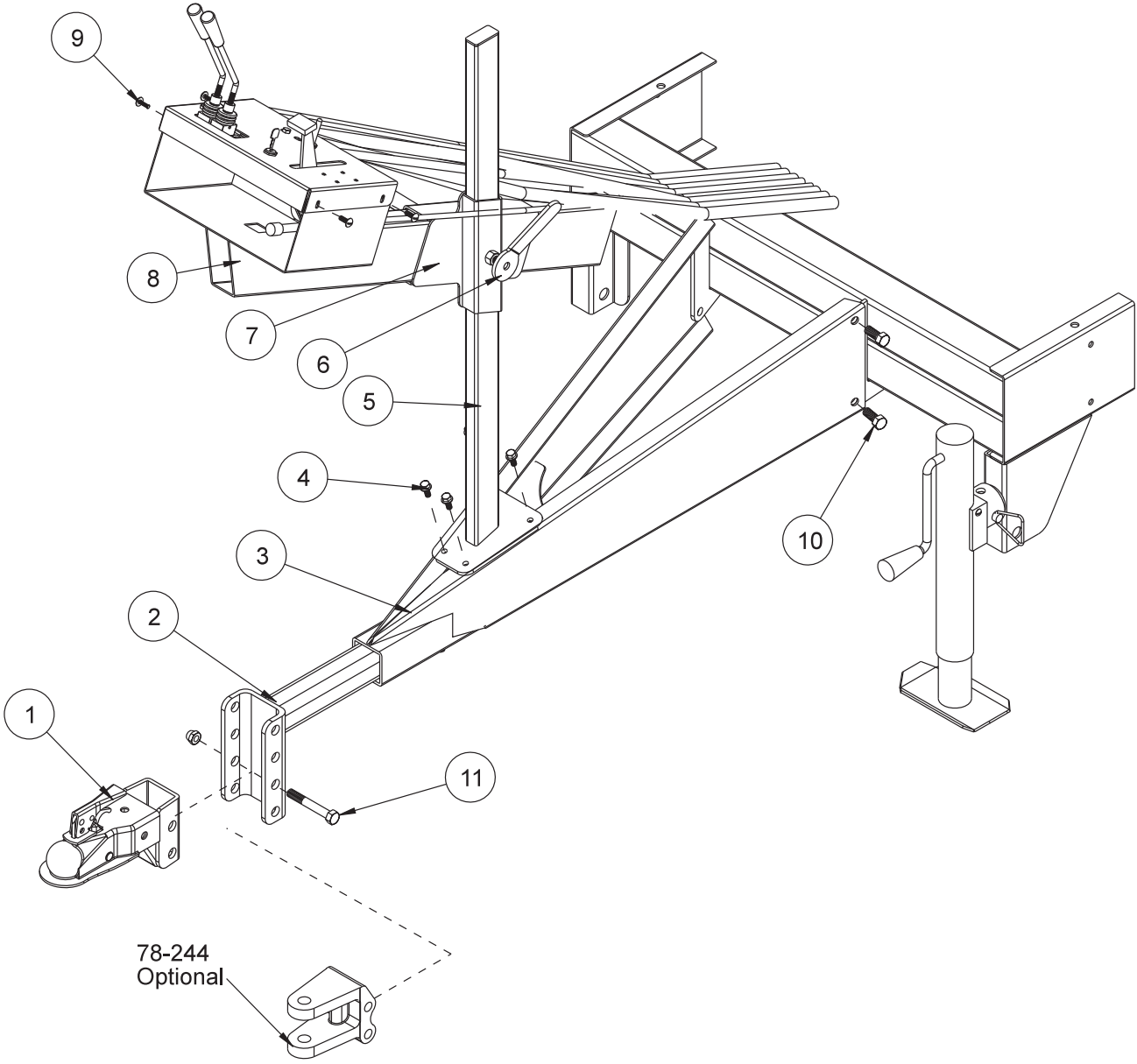

Accessories

78-209 BALL HITCH PARTS LIST

REF#	PART#	DESCRIPTION	QUANTITY
1	78-356	2" Ball Coupler	1
2	78-268	Hitch Insert	1
3	78-267	Tongue	1
4	HBFL-516-18-075	Flange Bolt $\frac{5}{16}$ - 18 x $\frac{3}{4}$	4
	HNFL-516-18	Flange Whiz Lock Nut $\frac{5}{16}$ - 18	4
5	78-299	Adjustment Slide	1
6	78-295	Adjustment Lock	2
	15-020	Hand Grip	2
7	78-298	Control Panel Adjustment	1
8	78-312	Control Panel Mount	1
9	HST-14-20-075	Truss Head Machine Screw $\frac{1}{4}$ - 20 x $\frac{3}{4}$ (part of machine)	4
	HNFL-14-20	Flange Whiz Lock Nut $\frac{1}{4}$ - 20 (part of machine)	4
10	HB-12-13-125	Bolt $\frac{1}{2}$ - 13 x $1\frac{1}{4}$	4
	HNTL-12-13	Lock Nut $\frac{1}{2}$ - 13	4
11	HB-58-11-450	Bolt $\frac{5}{8}$ - 11 x $4\frac{1}{2}$	2
	HNCL-58-11	Center Lock Nut $\frac{5}{8}$ - 13	2

INSTALLATION INSTRUCTIONS

Use two people to install hitches.

1. Block both wheels so machine does not roll.
2. Use the jack that is part of the sweeper to raise or lower sweeper to comfortable working height.
3. Slide the tongue (Ref 3) over the tabs on the front of the sweeper frame. Hitch must be on the outside. Use the four $\frac{1}{2}$ - 13 x $1\frac{1}{4}$ bolts (Ref 10) on the outside and four lock nuts on the inside. Tighten all four bolts.
4. Install adjustment slide (Ref 5) to tongue (Ref 3) using the four flange bolts $\frac{1}{4}$ - 20 x $\frac{3}{4}$ and four flange whiz lock nuts $\frac{1}{4}$ - 20 (Ref 4).
5. Loosen adjustment locks (Ref 6) on control panel adjustment (Ref 7) and put control panel adjustment onto the adjustment slide.
6. Tighten one adjustment lock (Ref 6).
7. Slide the control panel mount (Ref 8) through the control panel adjustment (Ref 7) and tighten the other adjustment lock (Ref 6).
8. The control panel has all the hoses, wiring and throttle cable connected to it and to the sweeper. The control panel is wrapped and fastened to the front of the sweeper.
9. Remove the control panel from the sweeper, bring it forward with the hoses to the rear and the throttle on the left hand side.
10. Fasten the control panel to the control panel mount with the four truss head machine screws $\frac{1}{4}$ - 20 x $\frac{3}{4}$ and four flange whiz lock nuts $\frac{1}{4}$ - 20 (Ref 9).
11. Put the two handles onto the valve and tighten the lock nuts with the handles pointing forward.
12. Place three hoses and the throttle cable on the left hand side of the adjustment slide.



Do not tow on public roads.

78-207 HYDRAULIC LIFT KIT DRAWING

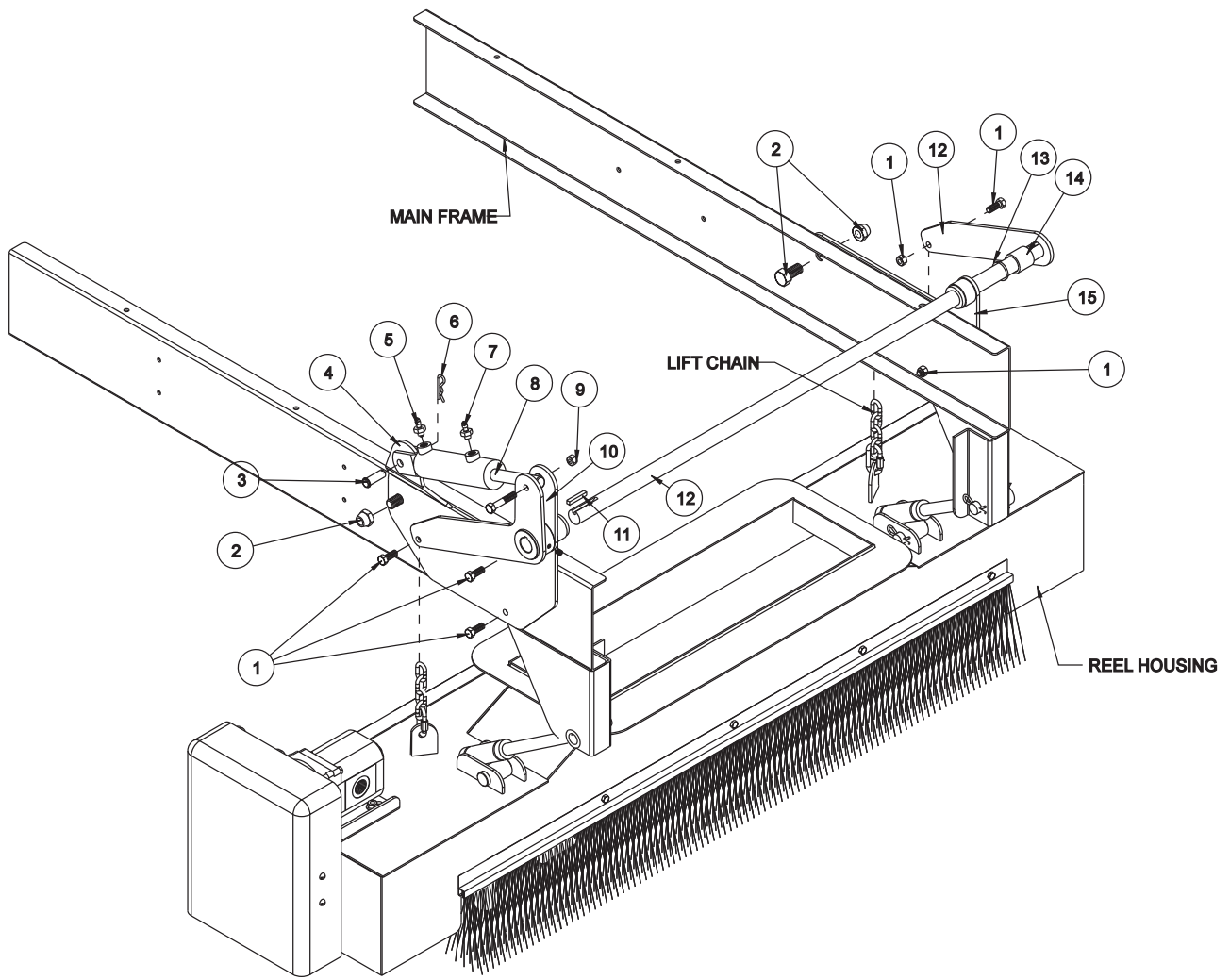

Accessories

78-207 HYDRAULIC LIFT KIT PARTS LIST

REF#	PART#	DESCRIPTION	QUANTITY
1	HB-38-16-100	Bolt $\frac{3}{8}$ - 16 x 1	6
	HNFL-38-16	Whiz Lock Nut $\frac{3}{8}$ - 16	6
2	HB-58-11-200	Bolt $\frac{5}{8}$ - 11 x 2	2
	HNTL-58-11	Lock Nut $\frac{5}{8}$ - 11	2
3	HCP-12-150	Clevis Pin $\frac{1}{2}$ x $1\frac{1}{2}$	1
4	78-357	Right Hydraulic Lift Mount	1
	18-223	Flange Bushing (part of 78-357)	1
	HMB-100-10	Machine Bushing 1 x 10GA	1
5	78-365	Adapter with Orifice	1
	78-364	Hydraulic Hose	1
6	HHP-18	Bridge Pin $\frac{1}{8}$	1
7	18-169	Adapter $\frac{3}{8}$	1
	78-364	Hydraulic Hose	1
8*	13-292	Hydraulic Cylinder	1
9	HB-38-16-200	Bolt $\frac{3}{8}$ - 16 x 2	1
	HW-38	Washer $\frac{3}{8}$	2
	HNTL-38-16	Lock Nut $\frac{3}{8}$ - 16	1
10	78-358	Chain Lift	1
	HSSHS-38-16-063	Set Screw $\frac{3}{8}$ - 16 x $\frac{5}{8}$ (comes with 78-358)	2
11	HKSQ-14-150	Machine Key $\frac{1}{4}$ x $\frac{1}{4}$ x $1\frac{1}{2}$	2
12	78-360	Lift Pivot	1
13	HMB-100-10	Machine Bushing 1 x 10GA	1
14	78-366	Spacer	1
15	78-361	Left Hydraulic Lift Mount	1
	18-223	Flange Bushing (part of 78-361)	1
*	14-253	Seal Kit for cylinders with part number stamped on cylinder and a retaining ring on rod end.	
*	14-267	Seal Kit for cylinders with part number stamped on cylinder and a spanner nut on the rod end.	

78-416 3 - BANK HYDRAULIC VALVE DRAWING

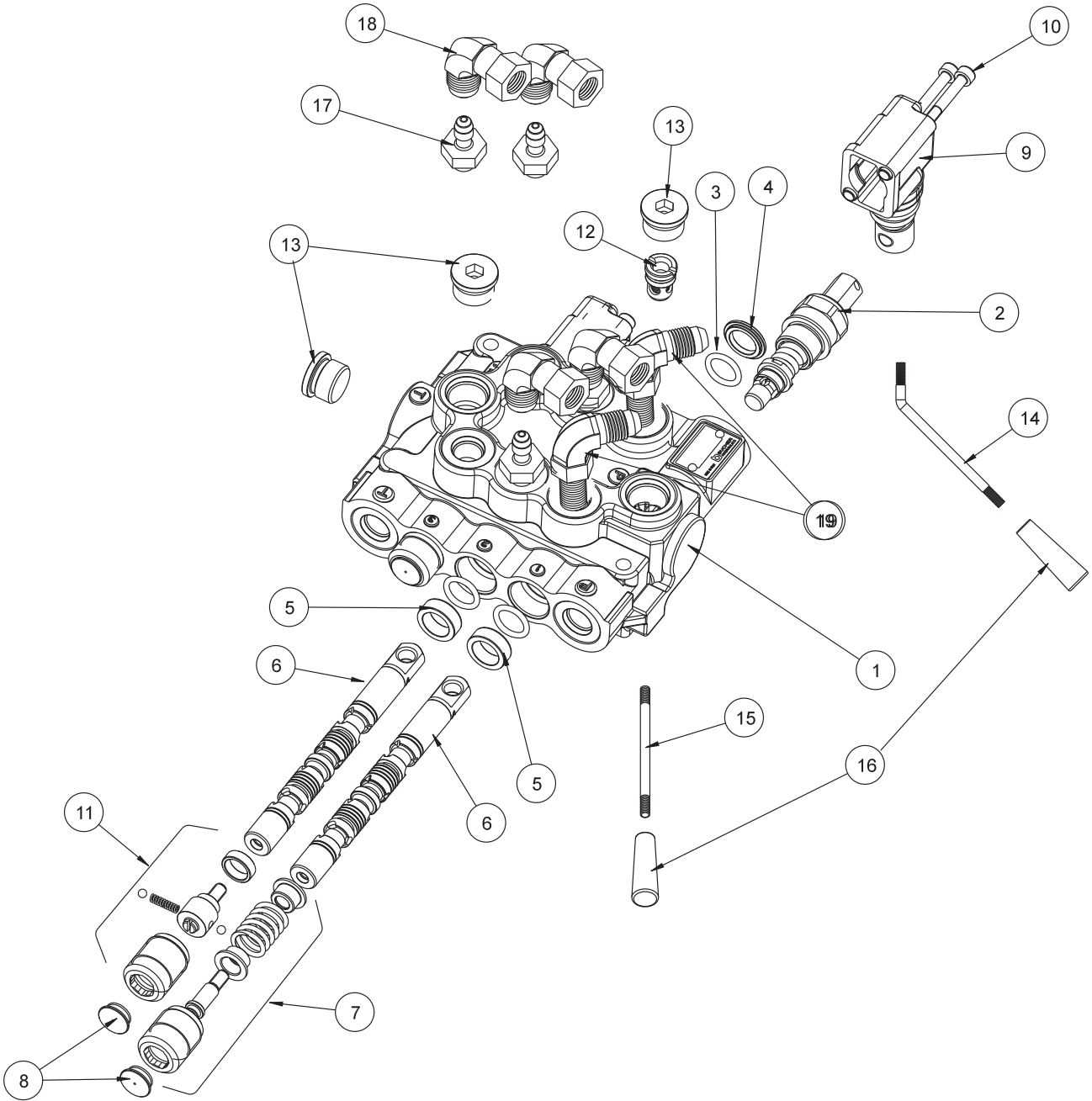

Accessories

78-416 3 - BANK HYDRAULIC VALVE PARTSLIST

REF#	PART#	DESCRIPTION	QUANTITY
1*	78-416-01	Body (complete with spacer and check valve)	1
2*	78-415-02	Spool HDM10	1
3*	78-415-03	O-Ring Seal	6
4*	78-415-04	Flanged Washer HDM10	3
5*	78-415-05	Spacer	3
6*	78-415-06	A Type Spool HDS11	3
7*	78-415-11	Positioner HDM10	2
8*	78-415-08	Plug	3
9*	78-415-09	Lever Group HDS11	3
10*	78-415-10	Metric Socket Screw M5 x .8 x 45	6
11*	78-415-07	Positioner	1
12*	78-415-12	Check Valve Assembly HDM12	1
13*	78-415-13	³ / ₄ - 16 SAE 8 Screw Plug	3
14	78-418	Bent Handle	2
15	78-417	Straight Handle (center)	1
16		Tapered Knob	3
17	18-169	Adapter SAE 3/8	4
18	18-202	Elbow	4
19	18-168	Elbow 3/8 Straight Thread	2
* 	78-416	3 – Bank Hydraulic Valve (includes all * items)	

78-208 FILTER SYSTEM DRAWING

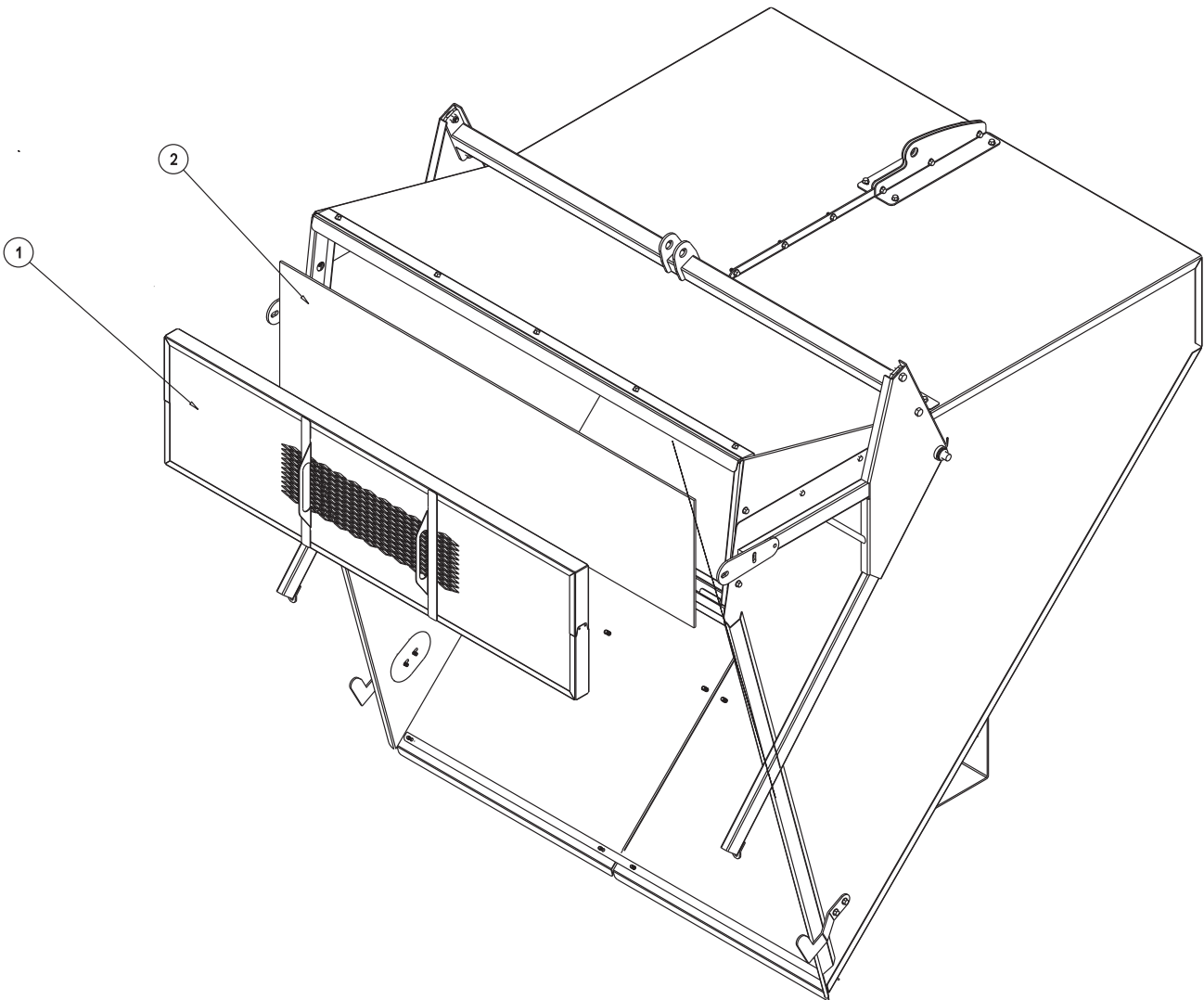

Accessories

78-208 FILTER SYSTEM PARTS LIST

REF#	PART#	DESCRIPTION	QUANTITY
1	78-288	Filter Case	1
2	78-328	Filter	1

78-210 & 78-211 REEL AND HYDRAULIC PUMP DRAWING

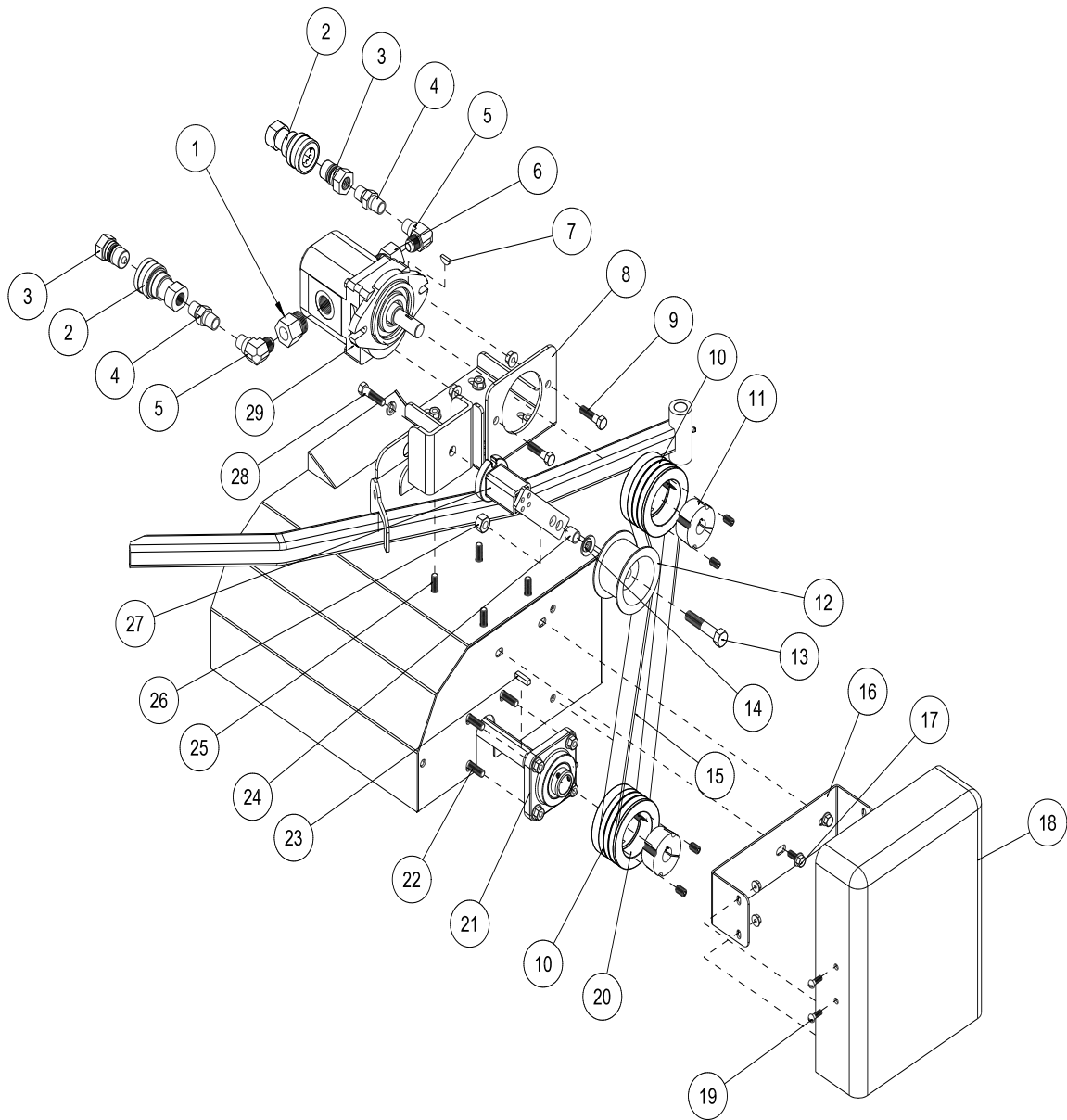

Accessories

78-210 & 78-211 REEL AND HYDRAULIC PUMP DRAWING

REF#	PART#	DESCRIPTION	QUANTITY
1	18-240	Pipe Adapter	1
2	78-228	Coupler 1/2"	2
3	78-229	Nipple 1/2"	2
4	18-334	Nipple	2
5	18-009	Elbow	2
6	18-333	Adapter	1
7	HWK-316-063	Woodruff key 3/16 x 5/8	1
8	78-259	Hydraulic Motor Mount	1
9	HB-38-16-150	Bolt 3/8 - 16 x 1 1/2	2
	HNFL-38-16	Flange Whiz Lock Nut 3/8 - 16	2
10	78-424	Pulley	2
11	78-428	Hub 3/4	1
	HSSHS-38-16-063	Set Screw 3/8 - 16 x 5/8 (part of 78-237)	2
12	16-013	Idler Pulley	1
13	HB-12-13-250	Bolt 1/2 - 13 x 2 1/2 (part of 78-224)	1
14	HMB-12-14	Machine Bushing 1/2 x 14GA	2
15	78-226	Belt, Single	3
16	72-058	Belt Guard Mount Bracket	1
17	HBFL-516-18-075	Flange Bolt 5/16 - 18 x 3/4	2
	HNFL-516-18	Flange Whiz Lock Nut 5/16 - 18	2
18	72-056	Plastic Belt Guard	1
19	HST-14-20-075	Truss Head Machine Screw 1/4 - 20 x 3/4	4
	HNFL-14-20	Flange Whiz Lock Nut 1/4 - 20	4
20	78-429	Hub 1"	1
	HSSHS-38-16-063	Set Screw 3/8 - 16 x 5/8 (part of 78-351)	2
21	78-222	Mounted Bearing (1" bore)	2
22	HB-38-16-125	Bolt 3/8 - 16 x 1 1/4	8
	HNFL-38-16	Flange Whiz Lock Nut 3/8 - 16	8
23	HKSQ-14-100	Machine Key 1/4 x 1/4 x 1	1
24	76-275	Spacer (part of 78-224)	1
25	HB-38-16-100	Bolt 3/8 - 16 x 1	4
	HNFL-38-16	Flange Whiz Lock Nut 3/8 - 16	4
26	HNCL-12-13	Center Lock Nut 1/2 - 13 (part of 78-224)	1
27	78-224	Belt Tensioner	1
28	HBM-10-1.5-30	Metric Bolt 10 - 1.5 x 30 (part of 78-224)	1
	HWLM-10	Metric Lockwasher 10 (part of 78-224)	1
29*	78-414	Hydraulic Motor	1

* NO OTHER PARTS ARE REPLACEABLE FOR HYDRAULIC PUMP.

78-210 NYLON BRUSH HEAD DRAWING

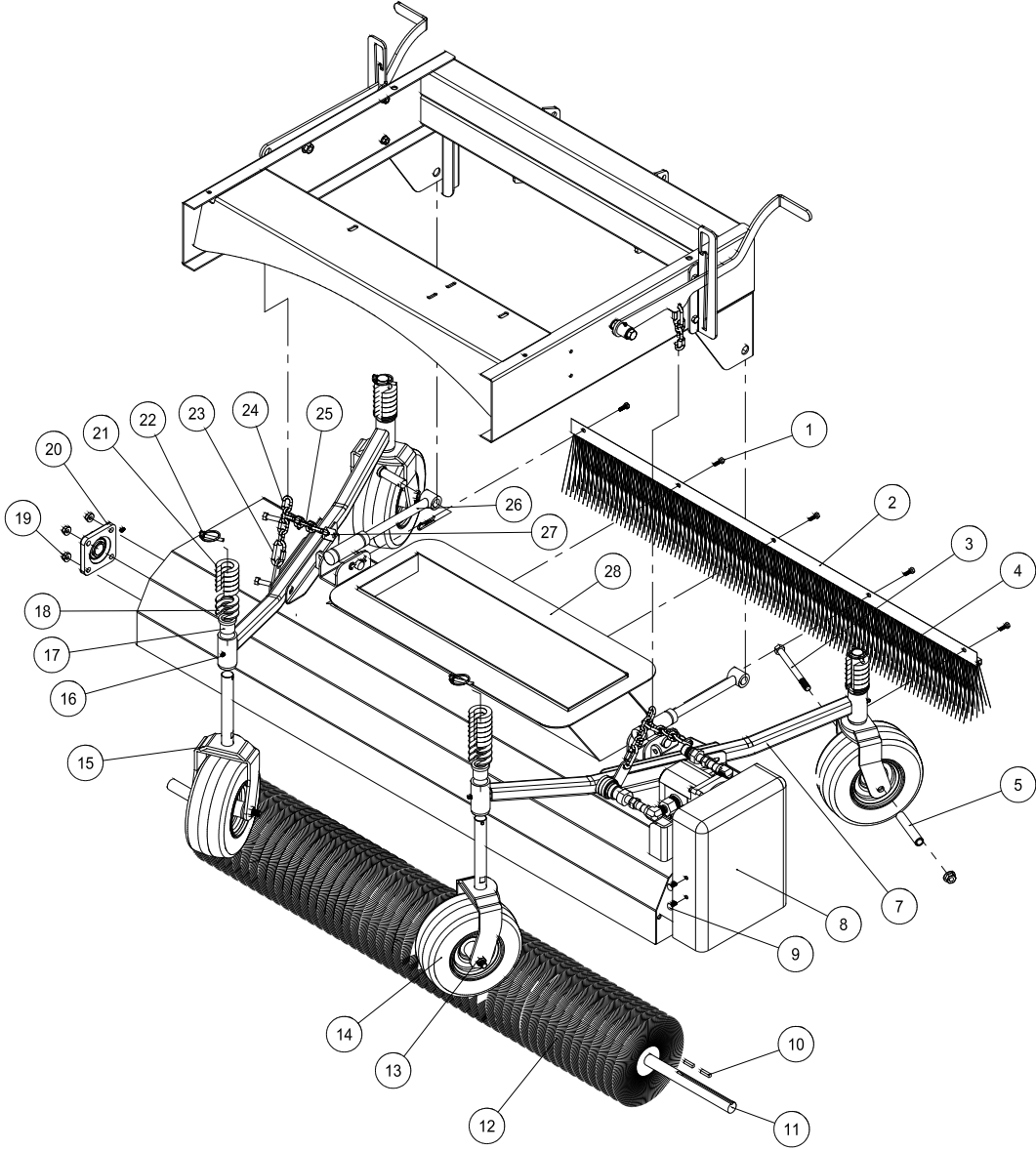

Accessories

78-210 NYLON BRUSH HEAD PARTS LIST

REF#	PART#	DESCRIPTION	QUANTITY
1	HB-14-20-075	Bolt $\frac{1}{4}$ - 20 x $\frac{3}{4}$	5
	HNFL-14-20	Flange Whiz Lock Nut $\frac{1}{4}$ - 20	5
2	78-344	Strip Brush Holder (drilled)	1
3	HB-12-13-600	Bolt $\frac{1}{2}$ - 13 x 6	4
4	78-322	Strip Brush	1
5	33-338	Axle Bearing	4
7	78-393	Castor Arm	2
	HB-38-16-250	Bolt $\frac{3}{8}$ - 16 x 2 $\frac{1}{2}$	4
	HW-38	Washer $\frac{3}{8}$	4
	HNFL-38-16	Flange Whiz Lock Nut $\frac{3}{8}$ - 16	4
8	72-056	Plastic Belt Guard	1
9	HSTP-14-20-075	Phillips Truss Head Machine Screw $\frac{1}{4}$ - 20 x $\frac{3}{4}$	4
	HNFL-14-20	Flange Whiz Lock Nut $\frac{1}{4}$ - 20	4
10	HKSQ-14-100	Machine Key $\frac{1}{4}$ x $\frac{1}{4}$ x 1	2
11	78-348	Shaft Spiral Brush	1
12	78-321	Spiral Brush	1
13	HNTL-12-13	Lock Nut $\frac{1}{2}$ - 13	4
14	42-202	Tire and Wheel	4
	42-202-01	Tire 9 x 3.5 x 4 Ply	4
	42-202-02	Wheel	4
	42-202-03	Cap	4
	42-202-04	Bearing	8
	42-202-05	Seal	8
15	78-434	Castor Fork	4
16	HG-14-28-180	Grease Fitting $\frac{1}{4}$ - 28 x 180° (part of 78-393)	2 per
17	18-223	Flange Bushing (part of 78-393)	4 per
18	72-136	Quick Spacer 10GA	12
19	HNFL-38-16	Flange Whiz Lock Nut $\frac{3}{8}$ - 16	8
	HB-38-16-125	Bolt $\frac{3}{8}$ - 16 x 1 $\frac{1}{4}$	8
20	78-222	Mounted Bearing (1" bore)	2
21	72-053	Quick Spacer $\frac{1}{2}$ "	24
22	42-539	Lynch Pin $\frac{1}{4}$	4
23	78-241	Chain Connector	8
24	8820-8	Machine Chain Straight Link	2
25	8820-3	Machine Chain Straight Link	2
26	78-271	Reel Lift Rod	2
	HCP-34-250	Clevis Pin $\frac{3}{4}$ x 2 $\frac{1}{2}$	2
	HHP-18	Bridge Pin $\frac{1}{8}$	2
27	78-421	Chain Bracket	4
28	78-401	Reel Housing	1
	8803-80	Trim Black	1

78-211 RUBBER FINGER HEAD DRAWING

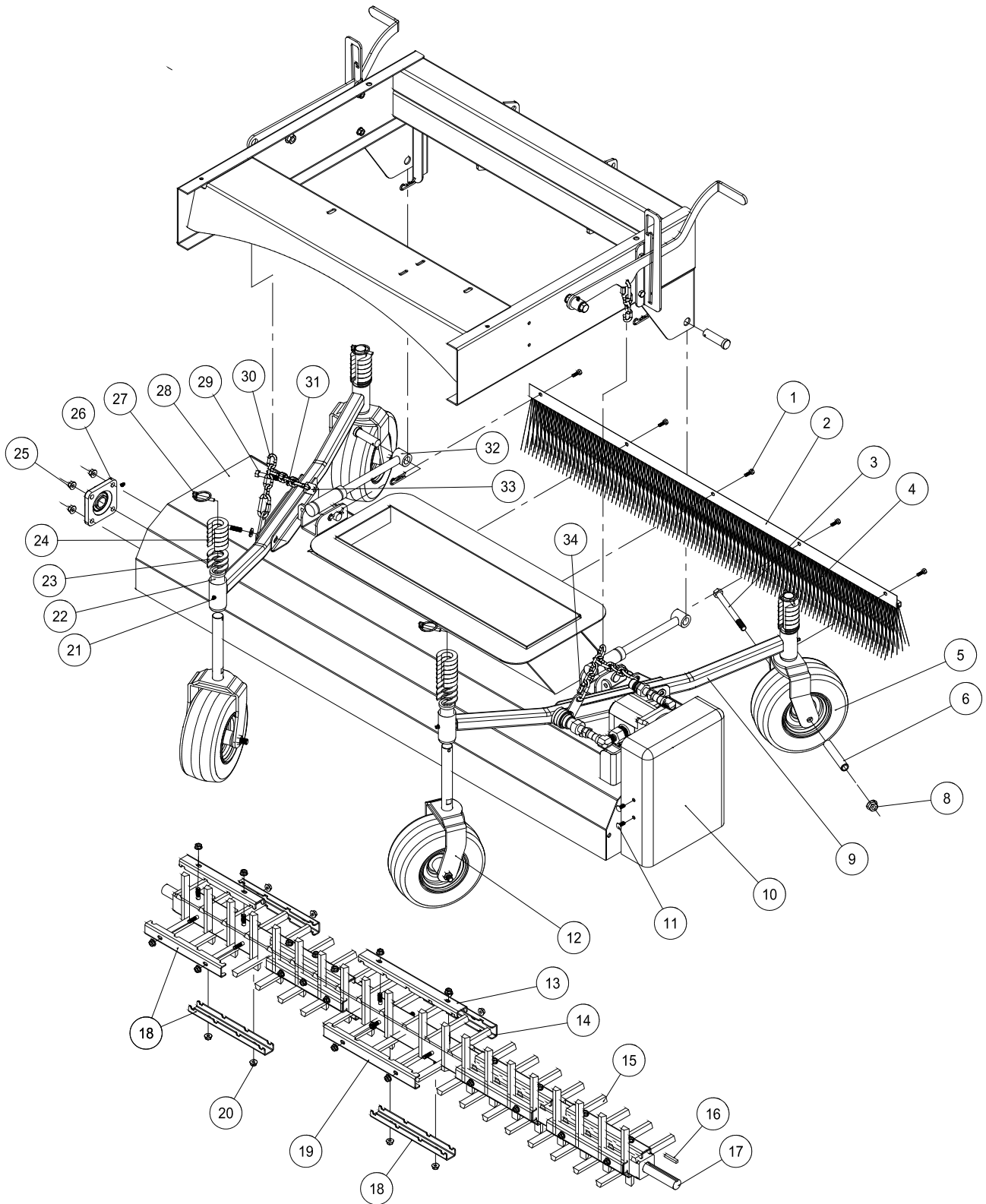

Accessories

78-211 RUBBER FINGER HEAD PARTS LIST

REF#	PART#	DESCRIPTION	QUANTITY
1	HB-14-20-075	Bolt $\frac{1}{4}$ - 20 x $\frac{3}{4}$	5
	HNFL-14-20	Flange Whiz Lock Nut $\frac{1}{4}$ - 20	5
2	78-344	Strip Brush Holder (drilled)	1
3	HB-12-13-600	Bolt $\frac{1}{2}$ - 13 x 6	4
4	78-322	Strip Brush	1
5	42-202	Tire & Wheel	4
6	33-338	Axle Bearing	4
8	HNTL-12-13	Lock Nut $\frac{1}{2}$ - 13	4
9	78-393	Castor Arm	2
10	72-056	Plastic Belt Guard	1
11	HSTP-14-20-075	Phillip Truss Head Machine Screw $\frac{1}{4}$ - 20 x $\frac{3}{4}$	4
	HNFL-14-20	Flange Whiz Lock Nut $\frac{1}{4}$ - 20	4
12	78-434	Castor Fork	4
13	78-287	Finger Clamp 13"	1
14	78-327	Finger Clamp 10.5"	1
15	8969-5.250	Sweeper Finger	81
16	HKSQ-14-100	Machine Key $\frac{1}{4}$ x $\frac{1}{4}$ x 1	1
17	78-303	Finger Reel Bar	1
18	78-297	Finger Clamp 10"	17
19	78-326	Finger Clamp 12"	1
20	HNFL-516-18	Flange Whiz Lock Nut $\frac{5}{16}$ - 18	40
21	HG-14-28-180	Grease Fitting $\frac{1}{4}$ - 28 x 180° (part of 78-393)	2 per
22	18-223	Flange Bushing (part of 78-393)	4 per
23	72-136	Quick Spacer 10GA	12
24	72-053	Quick Spacer $\frac{1}{2}$ "	24
25	HNFL-38-16	Flange Whiz Lock Nut $\frac{3}{4}$ - 16	8
	HB-38-16-125	Bolt $\frac{3}{4}$ - 16 x $1\frac{1}{4}$	8
26	78-222	Mounted Bearing (1" bore)	2
27	42-539	Lynch Pin $\frac{1}{4}$	4
28	78-401	Reel Housing	1
	8803-80	Trim Black	1
29	HB-38-16-250	Bolt $\frac{3}{8}$ - 16 x $2\frac{1}{2}$	4
	HW-38	Washer $\frac{3}{8}$	4
	HNFL-38-16	Flange Whiz Lock Nut $\frac{3}{8}$ - 16	4
30	8820-8	Machine Chain Straight Link	2
31	8820-3	Machine Chain Straight Link	2
32	78-271	Reel Lift Rod	2
	HCP-34-250	Clevis Pin $\frac{3}{4}$ x $2\frac{1}{2}$	2
	HHP-18	Bridge Pin $\frac{1}{8}$	2
33	78-421	Chain Bracket	4
34	78-241	Chain Connector	4

This is a list of decals on the Sweep Star V62. Part numbers, description, and location will help in reordering decals.

16-088	Decal, Moving Parts/Hot	Top Reel Belt Guard & Left Side Frame
17-128	Decal, Radiator Coolant	Radiator Shield
25-004	Decal, Serial #	Left Front Main Frame
25-277	Decal, Battery Warning	Above Battery
25-279	Decal, safety	Brush/Finger Head
25-286	Decal, Pinch Point	2 Ea. Side Tailgate
25-298	Decal, Warning Hot	Muffler
25-307	Decal, Refueling w/ Gasoline	Above Gas Tank
25-344	Decal, 3" Star	Right Side Belt Guard
25-355	Decal, Tire Pressure (18 psi)	Rear Wheels
25-356	Decal, Tire Pressure (20 psi)	Castor Forks
25-359	Decal, Smithco (3.25 x 17.312)	Front Chute & Rear Tailgate
25-361	Decal, Technical Assistance	Main Frame
25-362	Decal, Danger Fire	Hopper Front
25-363	Decal, Max. Depth	Hopper Sides
27-093	Decal, Hydraulic Oil	Front Oil Tank Bracket
76-305	Decal, Rotating Parts	2 Blower Housing, Front Panel, Cover Plate
78-217	Decal, Operator Control Panel	Operator Control Panel
78-369	Decal, Sweep Star V62	2 Hopper Sides
78-407	Decal, Max. Load	Hopper Front

QUICK REFERENCE

REPLACEMENT FILTERS

23-031 Hydraulic Oil Filter Element
50-403 In-Line Fuel Filter

REPLACEMENT BELTS

78-443 3-V Belt

SEAL KITS

78-414 Hydraulic Motor (reel)
72-186-01 Seal Kit

75-714 Tailgate Cylinder
14-254 Seal Kit

78-415 2-Bank Hydraulic Valve
78-415-03 Seal Kit

78-413 Hydraulic Pump
78-413-01 Seal Kit

OTHER PARTS

Spark Plug NGK BMR 6A or equivalent
Gap .024-.028 in. (.6-.7 mm)
Torque 12 Ft. Lbs. (17 Nm)

FLUIDS

Engine Oil SAE 10W-40 API Service SJ or higher Motor Oil
Hydraulic Fluid SAE 10W-40 API Service SJ or higher Motor Oil
Coolant Permanent Type Antifreeze for Aluminum Engine and
Radiator Green. 50% Solution of Ethylene Glyco.

The Smithco Commercial Products Two-Year Limited Warranty

The Smithco Commercial Products Two-Year Limited Warranty

Smithco, Inc. (Smithco) warrants your 2016 or newer Smithco Commercial Product ("Product") purchased after October 1, 2016 to be free from defects in materials or workmanship for the period of time listed below. Where a warrantable condition exists, Smithco will repair the Product at no cost to you including diagnosis, labor (at the Smithco standard labor rate, subject to the Smithco flat rate schedule), and parts.

Warranty Duration is:

- (1) Two years, 1500 operational hours* from the date of delivery to the original purchaser or Five years from the date of original manufacturer of the product, whichever occurs first. (*Products equipped with hour meter).
- (2) Products used in rental situations are covered for 90 days from date of delivery to original user/renter.

Owner Responsibilities:

As the Product owner, you are responsible for required maintenance and adjustments stated in your Owner's Manual. Failure to perform required maintenance and adjustments can be grounds for disallowing a warranty claim. **You are particularly responsible to train all present and future operators of this product on the safe operation of this product at your location.**

Instructions for Obtaining Warranty Service:

You are responsible for notifying the Authorized Smithco Products Distributor from whom you purchased the Product as soon as you believe a warrantable condition exists and not later than 30 days from discovery of the condition.





If you need help locating an Authorized Smithco Distributor, or if you have questions regarding your warranty rights or responsibilities, you may contact us at:

Smithco Product Support Department
200 West Poplar Ave.
Cameron, Wisconsin 54822
Telephone: 800-891-9435 E-Mail: ProductSupport@Smithco.com

Maintenance Parts:

Parts scheduled for replacement as required maintenance ("Maintenance Parts"), are warranted for the period of time up to the scheduled replacement time for that part.

Items/Conditions Not Covered:

-  Not all product failures or malfunctions that occur during the warranty period are defects in materials or workmanship. The items/conditions listed below are not covered by this warranty:
-  Product failures which result from the use of non-Smithco replacement parts, or from installation and use of add-on, modified, or unapproved accessories are not covered.
-  Product failures which result from failure to perform required maintenance and/or adjustments are not covered.
-  Product failures that result from operating the Product in an abusive, negligent or reckless manner are not covered.



This warranty does not apply to parts subject to consumption through use, unless found to be defective. Examples of parts which are consumed, or used up, during normal Product operation include, but are not limited to: blades, tines, teeth, scarifiers, rakes, plates, wear plates, castor wheels, tires, batteries, filters, belts, nozzles, etc.



This warranty does not apply to failures caused by outside influence. Items considered to be outside influence include, but are not limited to, weather, storage practices, contamination, use of unapproved coolants, lubricants, additives, or chemicals, etc.



This warranty does not apply to normal "wear and tear" items. Normal "Wear and Tear" includes, but is not limited to, damage to seats due to wear or abrasion, worn painted surfaces, scratched decals or windows, etc.



Smithco may require the return of failed parts or components in order to determine the validity of any warranty claim.



Smithco will not be obligated to replace components of other manufacturers if inspection by the original component manufacturer indicates that failure was due to normal wear and tear, expected consumption through use or improper care or service.

Other Legal Disclaimers:

The above remedy for product defects through repair or replacement by an authorized Smithco distributor or dealer is the purchaser's sole remedy for any defect. This warranty gives you specific legal rights, and you may also have other rights which vary from state to state.

THERE ARE NO OTHER EXPRESS WARRANTIES OTHER THAN THOSE SET FORTH ABOVE. ALL IMPLIED WARRANTIES OF MERCHANTABILITY AND FITNESS FOR USE ARE LIMITED TO THE DURATION OF THE LIMITED WARRANTIES CONTAINED HEREIN.

Some states may not allow limitations on how long an implied warranty lasts, so the above limitation may not apply to you.

THE SMITHCO COMPANY IS NOT LIABLE FOR INDIRECT, INCIDENTAL OR CONSEQUENTIAL DAMAGES IN CONNECTION WITH THE USE OF THE PRODUCT, INCLUDING ANY COST OR EXPENSE OF PROVIDING A SUBSTITUTE PRODUCT OR SERVICE DURING PERIODS OF MALFUNCTION OR NON-USE.

Some states may not allow the exclusion of indirect, incidental or consequential damages, so the above exclusion may not apply to you.

