

**SMITHCO**

Wayne, Pennsylvania 19087

# **PARTS & SERVICE MANUAL**

## **Big Vac**

### **Models 72-000-A**

**Starting Serial # 72052**

**December, 2001**

SMITHCO PRODUCT SUPPORT

1-800-891-9435

Hwy SS and Poplar Avenue, Cameron WI 54822

E-mail: [productsupport@smithco.com](mailto:productsupport@smithco.com)

<b>Introduction</b> .....	<b>1-4</b>
Introduction .....	1
Safe Practices .....	2
PTO Safety Warnings .....	3
Specifications .....	4
Optional Equipment .....	4
<b>Service</b> .....	<b>5-11</b>
Maintenance .....	5-6
Overloading Debris Hopper and Vacuum Housing Wear .....	7
Service Chart .....	8
End User's Service Chart .....	9
Adjustments .....	10-11
Storage .....	11
<b>Diagrams</b> .....	<b>12-13</b>
Hydraulic Diagram .....	12-13
Hydraulic Schematic .....	12
<b>Parts</b> .....	<b>14-31</b>
Big Vac Main .....	14-15
Control Panel .....	16-17
Oil Tank .....	18-19
Blower Housing .....	20-21
Vacuum Housing Belts and Tensioners .....	22-23
Hopper .....	24-25
72-151 Hydraulic Valve .....	26-27
78-363 3 Bank Hydraulic Valve .....	28-29
72-048 Axle .....	30-31
72-055 PTO Shaft .....	30-31
<b>Accessories</b> .....	<b>32-48</b>
72-001 Combination Sweeper - Verticut Head .....	32-37
72-002 Rubber Finger Sweeper Head .....	38-41
72-004 Over-The-Road Towing Package .....	42-44
72-003 Hand Held Vacuum Hose .....	46-48
<b>Reference</b> .....	<b>49-50</b>
Decal List .....	49
Quick Reference Replacement Parts .....	50
Warranty .....	Inside Back Cover

Thank you for purchasing a **Smithco** product.

Read this manual and all other manuals pertaining to the Big Vac carefully as they contain safety, operating, assembly and maintenance instructions. Failure to do so could result in personal injury or equipment damage. Keep manuals in a safe place after operator and maintenance personnel have read them. Right and left sides are from the operator's seat, facing forward.

All **Smithco** machines have a Serial Number and Model Number. Both numbers are needed when ordering parts. The serial number plate on the Big Vac is located on the front cross member of the frame.

For easy access record your Serial and Model numbers here.

<b>SMITHCO</b>		DATE OF MFG.
WAYNE, PENNSYLVANIA 19087 USA 610-688-4009 Fax 610-688-6069		<input type="text"/>
SERIAL NO.	kW/hp	
<input type="text"/>	<input type="text"/>	
MODEL NO.	kg/lb	
<input type="text"/>	<input type="text"/>	



Information needed when ordering replacement parts:

1. Model Number of machine
2. Serial Number of machine
3. Name and Part Number of part
4. Quantity of parts



## SAFE PRACTICES

1. It is your responsibility to read this manual and all publications associated with this machine (engine, accessories and attachments).
2. Never allow anyone to operate or service the machine or its attachments without proper training and instructions. Never allow minors to operate any equipment.
3. Learn the proper use of the machine, the location and purpose of all the controls and gauges before you operate the equipment. Working with unfamiliar equipment can lead to accidents.
4. Wear all the necessary Personal Protective Equipment (PPE) to protect our head, eyes, ears, hands and feet. **Ear and eye protection are required.** Operate the machine only in daylight or in good artificial light.
5. Inspect the area where the equipment will be used. Beware of overhead obstructions and underground obstacles. Stay alert for hidden hazards.
6. Never operate equipment that is not in perfect working order or without decals, guards, shields, or other protective devices in place.
7. Never disconnect or bypass any switch.
8. Carbon monoxide in the exhaust fumes can be fatal when inhaled, never operate a machine without proper ventilation.
9. Never use your hands to search for oil leaks. Hydraulic fluid under pressure can penetrate the skin and cause serious injury.
10. This machine demands your attention. To prevent loss of control or tipping of the vehicle:
  - A. Use extra caution in backing up the vehicle. Ensure area is clear.
  - B. Do not stop or start suddenly on any slope.
  - C. Reduce speed on slopes and in sharp turns. Use caution when changing directions on slopes.
  - D. Stay alert for holes in the terrain and other hidden hazards.
  - E. Operate equipment up and down slopes, never across the face.
11. Before leaving operator's position for any reason:
  - A. Disengage all drives.
  - B. Lower all attachments to the ground.
  - C. Shut engine off and remove the ignition key.
12. Keep hands, feet and clothing away from moving parts. Wait for all movement to stop before you clean, adjust or service the machine.
13. The rubber fingers, sweeper and vacuum pick up and propel debris and small objects in machines path during operation. Keep the area of operation clear of all bystanders.
14. Never carry passengers.
15. Use parts and materials supplied by \_\_\_\_\_ only. Do not modify any function or part.
16. Avoid sharp turns. Watch the tires of the tractor while turning to make sure they do not contact the tongue of the Big Vac.
17. Shut down power source before attempting to unclog any part of the machine.
18. If reel deck and/or blower began to vibrate abnormally, immediately shut off power and determine the cause.

These machines are intended for professional maintenance on large turf areas such as golf courses, baseball fields, parks, recreation areas, and many other large open areas. Other use is forbidden.



1. Always disengage the PTO, shut off engine and remove the keys before leaving the tractor seat.
2. Keep the tractor's master shield in place at all times.
3. Missing or damaged shielding is the main reason for driveline entanglement. **Keep All Guards** on and in good condition. Check guards frequently.
4. **Never** step across a rotating powershaft. Always walk around the revolving shaft even if guards are in place.
5. Dress for safety. Do not wear loose fitting clothes or jewelry and keep long hair covered or pulled back.
6. The tractor drawbar should be adjusted to the length specified in the driven machine's manual. This will help prevent driveline stress and separation on uneven terrain and in tight turns.
7. A PTO shaft may break or separate during operation if improperly installed or adjusted. Be sure PTO shaft is installed properly.
8. Never perform maintenance or adjustments until both the driveline and the machinery have stopped moving.
9. Warn anyone who might come near an operating PTO about the entanglement hazard.
10. Regularly test driveline guards by spinning or rotating them to ensure they have not become stuck to the shaft.
11. Always use the driveline recommended for your machine. Never switch drivelines among different machines.
12. Reduce PTO shaft abuse by observing the following:
  - a. Avoid tight turns that pinch rotating shafts between the tractor and machine.
  - b. Keep excessive telescoping to a minimum.
  - c. Engage power to the shaft gradually.
  - d. Avoid over tightening of slip clutches on PTO driven machines.

## SPECIFICATIONS FOR BIG VAC

### WEIGHTS AND DIMENSIONS

Length	180" (458 cm)
Width	84" (214 cm)
Height	87" (221 cm)
Weight	3500 lb (1588 kg)

### SOUND LEVEL

At Ear Level	92 dB (Use ear protection while operating)
--------------	--

### PTO SHAFT

Maximum RPM	540
-------------	-----

### TIRES & WHEELS

Two 26.5 - 1400 x 12 (18 psi (1.3 bar)) Fairway Type Turf Tires  
Castor: 6 x 12 (20 psi (1.4 bar))

### FLUID CAPACITY

Hydraulic Fluid	17 gallon (64 liters)
Grade of Hydraulic Fluid	SAE 10W-40 API Service SJ or higher Motor Oil

## OPTIONAL EQUIPMENT

- 72-001 Combination Verticut and Sweeper Head
- 72-002 Rubber Finger Sweeper Head
- 72-245 2<sup>5</sup>/<sub>16</sub> Ball Hitch





**CAUTION**

Before servicing or making adjustments to machine, stop engine on tow vehicle and remove key from ignition.



**NOTE:**

Use all procedures and parts prescribed by the manufacturer's. Read the engine manual before operation.

**LUBRICATION**

Use No. 2 General Purpose Lithium Base Grease and lubricate every 100 hours. The Big Vac has 19 to 25 grease fittings, depending on what sweeper head you are using. All bearings are sealed bearings. When inserting grease, be careful not to ruin the seal, if this happens, replace the bearing at once. Be sure to wipe grease fitting clean before injecting grease. Give only one or two pumps of grease at each lubrication.

**REF# LOCATION**

- 1 One on all four castor wheels.
- 2 Four on the front of the blower that go to pillow blocks on blower and PTO shafts.
- 3 One on each mounted bearing for reel shaft. Two for finger reel. Four for combination head.
- 4 One on each end of the PTO shaft.
- 5 One on all four castor wheel mount brackets.
- 6 One on the jack stand.
- 7 One on each end of roller - Combination head only.

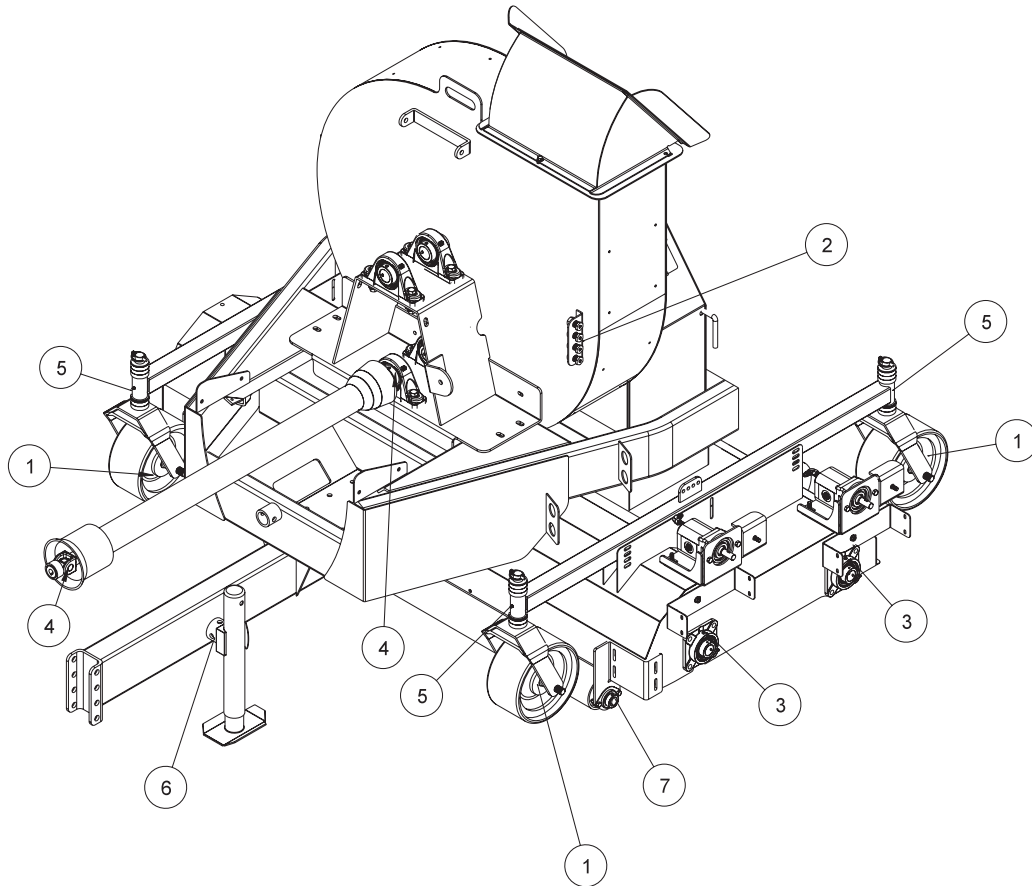

Service

## MAINTENANCE (CONTINUED)

### TIRE PRESSURE

Caution must be used when inflating a low tire to recommended pressure. Over inflating can cause tires to explode. Tires on the machine should be 18 psi (1.3 bar), castor wheels should be 20 psi (1.4 bar). Improper inflation will reduce tire life considerably.

### WHEEL MOUNTING PROCEDURE

1. Turn machine off and remove key.
2. Be sure unit is on a level surface. Unhitch from tow vehicle if possible.
3. Block the opposite wheel then the one you are working on.
4. Loosen nuts slightly on wheel to be removed.
5. Jack up machine being careful not to damage underside of machine.
6. Remove nuts, remove wheel.
7. Place new wheel on hub lining up bolt holes.
8. Torque nuts to 64-74 ft/lb (87-100 Nm) using a cross pattern. Torque again after first 10 hours and every 200 hours thereafter.
9. Lower machine to ground and remove blocks and jack.

### HYDRAULIC OIL

1. Use SAE 10W-40 API Service SJ or higher motor oil.
2. For proper warranty, change oil every 500 hours or annually, which ever is first and change the filter after the first 20 hours, then at 100 hours, then every 250 hours thereafter.
3. Inspect hydraulic lines for damage or leaks. Never use hands to inspect leaks.
4. Check hydraulic fluid level in tank. Look at the sight gauge on the front left side of the tank. The oil level should be at 90°C (194°F). If level is low, add SAE 10W-40 API Service SJ or higher motor oil.
5. After changing oil and/or filter, operate the machine for a few minutes. Check oil level and for leaks.
6. Always use caution when filling hydraulic oil tank or checking level to keep system free of contaminants. Check and service more frequently when operating in extremely cold, hot or dusty conditions.
7. If natural color of fluid is now black or smells burnt, it is possible that an overheating problem exists.
8. If fluid becomes milky, water contamination may be a problem.
9. If either of the above conditions happen, change oil and filter immediately after fluid is cool and find cause. Take fluid level readings when system is cold.
10. In extreme temperatures you can use straight weight oil. We recommend SAE 30W API Service SJ or higher when hot (above 90°F (33°C)) and SAE 10W API Service SJ or higher when cold (below 32°F (0°C)) ambient temperature. Use either motor oil or hydraulic oil, but do not mix.
11. Oil being added to the system must be the same as what is already in the tank. Mark tank fill area as to which type you put in.

### VERTICUT REEL VALVE HANDLE



**If the rubber finger sweeper head is installed on your unit and verticut reel handle is activated, the hydraulic system may be damaged due to overheating the oil. Remove the verticut reel valve handle when using the rubber finger sweeper head (72-002).**



## MAINTENANCE (CONTINUED)

### HOPPER LIFT SAFETY

The Hopper Lift Safety is used to support the ram on the hopper bottom in the extended position so you may service or repair the machine under the hopper. When not in use the Hopper Lift Safety can be stored on the hopper bed frame.

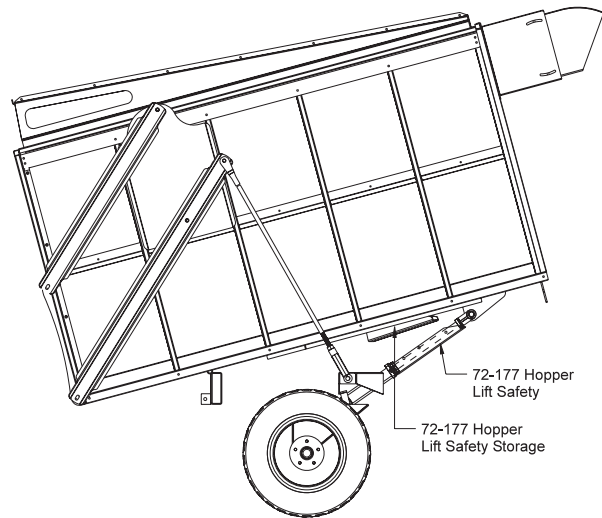

## OVERLOADING DEBRIS HOPPER AND VACUUM HOUSING WEAR

### SMITHCO SWEEPER-VACS ARE DESIGNED TO CARRY THE FOLLOWING MAXIMUM LOADS:

Model 72-000 Big Vac

1500 lbs. (608 kg)

### PLEASE NOTE THE FOLLOWING:

1. Loads heavier than that will damage the unit.
2. Such damage is not covered by warranty.
3. Overloading is particularly easy when collecting aerifier cores.
4. The hoppers on the Big Vac and V62 are large in order to hold 7 and 4 cubic yards respectively, of thatch, grass clippings, leaves and trash.
5. They will not hold 7 or 4 cubic yards of aerifier cores.
6. The maximum depth (in the debris hopper) of aerifier cores is:

Model 72-000 Big Vac

12 in. (30 cm)

### VACUUM HOUSING WEAR

The Big Vac & V62 are fitted with a wear resistant liner in the vacuum housing. This will provide additional husing life. Be sure the following points are explained to the user:

1. The vacuum housing and impeller must be cleaned each time the unit is used so the housing liner is inspected daily. Only Smithco Sweeper-Vacs provide a clean out/inspection port for easy inspection and cleaning.
2. When bare steel is visible at any point in the housing lining, the lining must be replaced. It is expected the liner will wear and be replaced. It is a vast improvement over competitive units with no liners.
3. Replacement of the liner or the vacuum housing due ti wear is normal and is not covered by warranty.
4. Collection of aerifier cores causes extreme wear on the liner (and if unchecked, on the housing).
5. Caution users that, while Smithco Sweeper-Vacs do an excellent job collecting cores, the lining (and the housing) will wear quickly in such use.

### RUBBERIZED BOOT

The rubberized boot between main unit and sweeper head is subject to wear and damage from debris. Unless defecative, replacement of this boot is not covered by warranty.



# SERVICE CHART



**CAUTION** Before servicing or making adjustments to the machine, stop engine, set park break, block wheels and remove key from ignition.



**NOTE:** Follow all procedures and **ONLY** use parts prescribed by the manufacturer. Read the engine manual before maintenance.

	Daily	As Required	100 Hours	200 Hours	250 Hours	300 Hours	400 Hours	Every 500 Hours/Yearly
Oil Engine Oil	C	R	R	R		R	R	R
Engine Oil Filter				R			R	R
Engine for Leaks and Loose Parts	C		C	C		C	C	C
‡ Air Cleaner (Paper Element)		R	C	C		R	C	R
‡ Air Cleaner (Foam Element every 25 hours)		R	C	C	C	R	C	R
Spark Plugs (Clean and Gap/Replace)		R	C	C		C	C	R
Valve Clearance								C
Idle Speed		C			C			C
‡ Cooling System	C		C	C		C	C	C
Belts and Hoses	C				C			C
* Tire Pressure	C		C	C		C	C	C
Visual Inspection of Tires	C		C	C		C	C	C
Fuel Level	C	C						
Fuel Filter		R						R
Hydraulic Oil	C		C	C		C	C	R
† Hydraulic Oil Filter					R			R
Hydraulic System for Leaks and Loose Parts	C		C	C		C	C	C
Battery Electrolyte Level			C	C		C	C	C
Clean Battery Terminals					C			C
§ Torque Lug Nuts				C			C	C
Lubricate Reel and Blower Shaft Bearings					C			C
Lubricate Castor Wheels (Every 25 hrs)	C	C						

C=Check or Clean at specified intervals

R=Replace at specified intervals

\* Tire pressure: Machine Tires 18 psi (1.3 bar) Castor Wheels 20 psi (1.4 bar)

† Replace hydraulic filter after the first 20, 100, and every 250 there after.

§ Torque tire nuts after the first 10 hours and every 200 hours there after (64 to 74 ft/lb (87-100 Nm))

‡ Kawasaki change oil after first 8 hours.

£ Change oil every 25 hours when operating under heavy load or in high ambient temperatures.

‡ Clean more often under dusty conditions or when airborne debris is present, replace air cleaner parts, if very dirty.

The suggested maintenance checklist is not offered as a replacement for the manufacturer's engine manual but as a supplement. You must adhere to the guidelines established by the manufacturer for warranty coverage. In adverse conditions such as dirt, mud or extreme temperatures, maintenance should be more frequent.



# END USER'S SERVICE CHART

	Daily	As Required	100 Hours	200 Hours	250 Hours	300 Hours	400 Hours	Every 500 Hours/Yearly
Ⓒ Engine Oil								
Engine Oil Filter								
Engine for Leaks and Loose Parts								
‡ Air Cleaner (Paper Element)								
‡ Air-Cleaner (Foam Element every 25 hours)								
Spark Plugs (Clean and Gap/Replace)								
Valve Clearance								
Idle Speed								
‡ Cooling System								
Belts and Hoses								
* Tire Pressure								
Visual Inspection of Tires								
Fuel Level								
Fuel Filter								
Hydraulic Oil								
†Hydraulic Oil Filter								
Hydraulic System for Leaks and Loose Parts								
Battery Electrolyte Level								
Clean Battery Terminals								
§ Torque Lug Nuts								
Lubricate Reel and Blower Shaft Bearings								
Lubricate Castor Wheels (Every 25 hrs)								

C=Check or Clean at specified intervals

R=Replace at specified intervals

\* Tire pressure: Machine Tires 18 psi (1.3 bar) Castor Wheels 20 psi (1.4 bar)

† Replace hydraulic filter after the first 20, 100, and every 250 there after.

§ Torque tire nuts after the first 10 hours and every 200 hours there after (64 to 74 ft/lb (87-100 Nm))

‡ Kawasaki change oil after first 8 hours.

£ Change oil every 25 hours when operating under heavy load or in high ambient temperatures.

‡ Clean more often under dusty conditions or when airborne debris is present , replace air cleaner parts, if very dirty.



## ADJUSTMENT OF BELT TENSIONER

There are four maximum belt tensioners on the Big Vac. Two control the tension on the belts on the blower housing, one each on the finger reel and the thatcher reel. The proper tension of the idler should be 12 to 15 as per the gauge (A) on the side of the tightener. Over tightening the belt will shorten the life of the belt and the machine may not perform to the best of its ability. To adjust belt tensioner, loosen bolt holding tensioner. Bring idler pulley tight to belts and turn tensioner into belts to 15°. Tighten holder bolt.

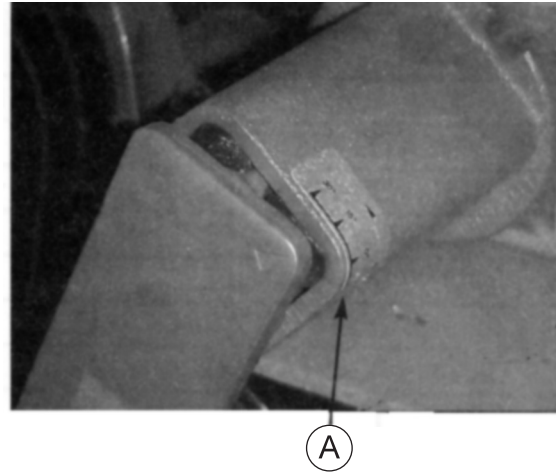

## CONTROL PANEL ADJUSTMENT ARM

On the right hand side of machine is the adjustment lock arm, by lifting up you can adjust the control panel by moving it forward or rearward. Make certain that the lock arm is locked back in place after adjustment. For up and down adjustment loosen the four adjustment bolts place the control panel to where you want it and tighten the four bolts.

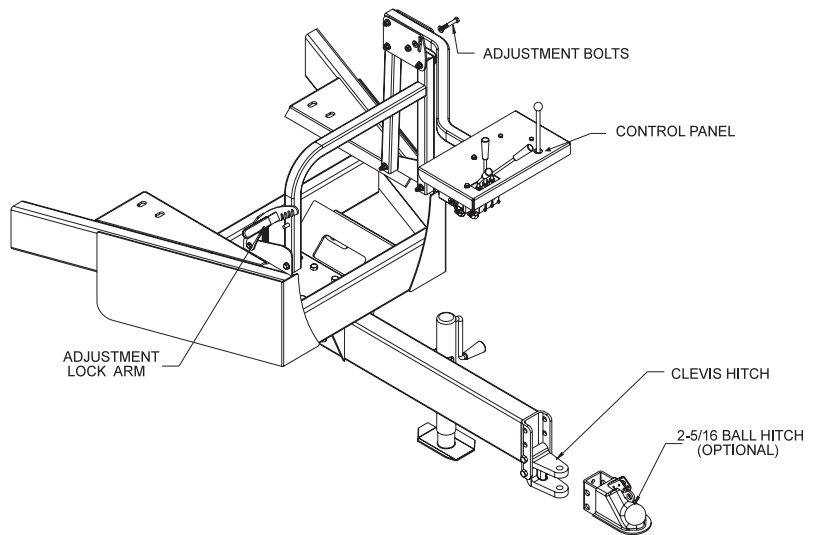

## HITCH OPTIONS

You may use the clevis hitch that is shipped with your machine or a 2<sup>5</sup>/<sub>16</sub> ball hitch that is an optional accessory. Both mount in the same location with three different bolt hole options.

## VERTICUT REEL VALVE HANDLE



If the rubber finger sweeper head is installed on your unit and verticut reel handle is activated, the hydraulic system may be damaged due to overheating the oil. Remove the verticut reel valve handle when using the rubber finger sweeper head (72-002).

## ADJUSTMENTS

### CASTOR WHEELS

The castor wheel height spacers are quick spacers meaning they have a slot cut out of them. The castor fork shaft has two flats on it near the bottom. To remove the quick spacers (A) lift up on the castor wheel (C) and remove lynch pin (B). Let the castor wheel come down some, take the quick spacer up and turn it until you feel the flats on the shaft then pull out. This removes the spacers below the castor arm (D), reverse the procedure to add spacers. The thin quick spacers must not be placed in line with the flats on the shaft or they will fall out. Check the tire pressure on castor wheels, they should be 20 psi (1.4 bar).

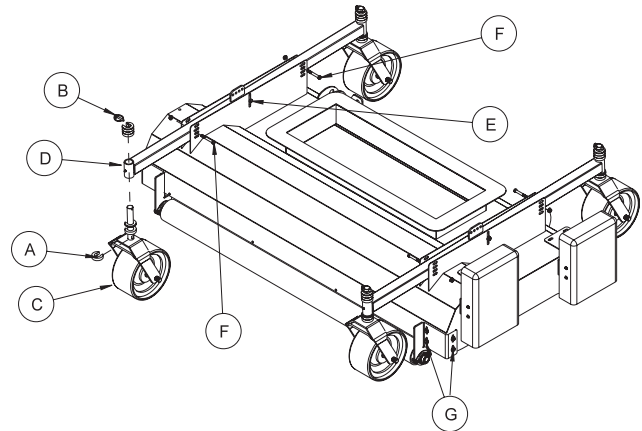

### DOUBLE REEL HOUSING

Normal setting is three slots down in front and two slots down in rear (both sides). You may want to change the normal setting to compensate for wear of the flail blades or sweeper fingers or to sweep without cutting. To do this loosen bolt (E) and remove bolts (F) both sides. Then tip the reel housing to the desired position. Replace bolts and tighten all bolts. This can also be done in conjunction with the castor wheel height adjustment spacers.

### ANTI SCALP ROLLER (DOUBLE REEL)

Normal setting for the anti scalp roller is with the machine on a level hard surface. Normal setting is with the bottom of the roller to be  $\frac{1}{4}$  inch above the flail blades, with flail blades in their lowest position. To adjust loosen the four bolts (G) both sides and slide the roller up or down. Tighten all bolts.

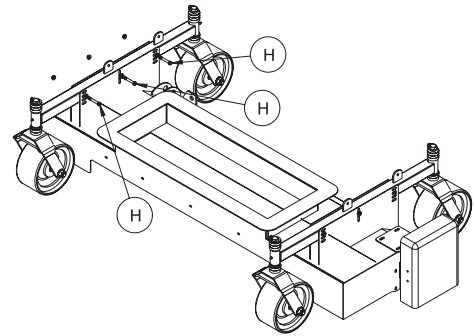

### SINGLE REEL HOUSING

Normal setting is two slots down (H) both front and rear (both sides).

## STORAGE

1. Before storing clean machine thoroughly.
2. Check bolts and nuts, tighten as necessary.
3. Make all repairs that are needed and remove any debris.
4. Store in a clean and dry area.

# HYDRAULIC DRAWING

Diagrams

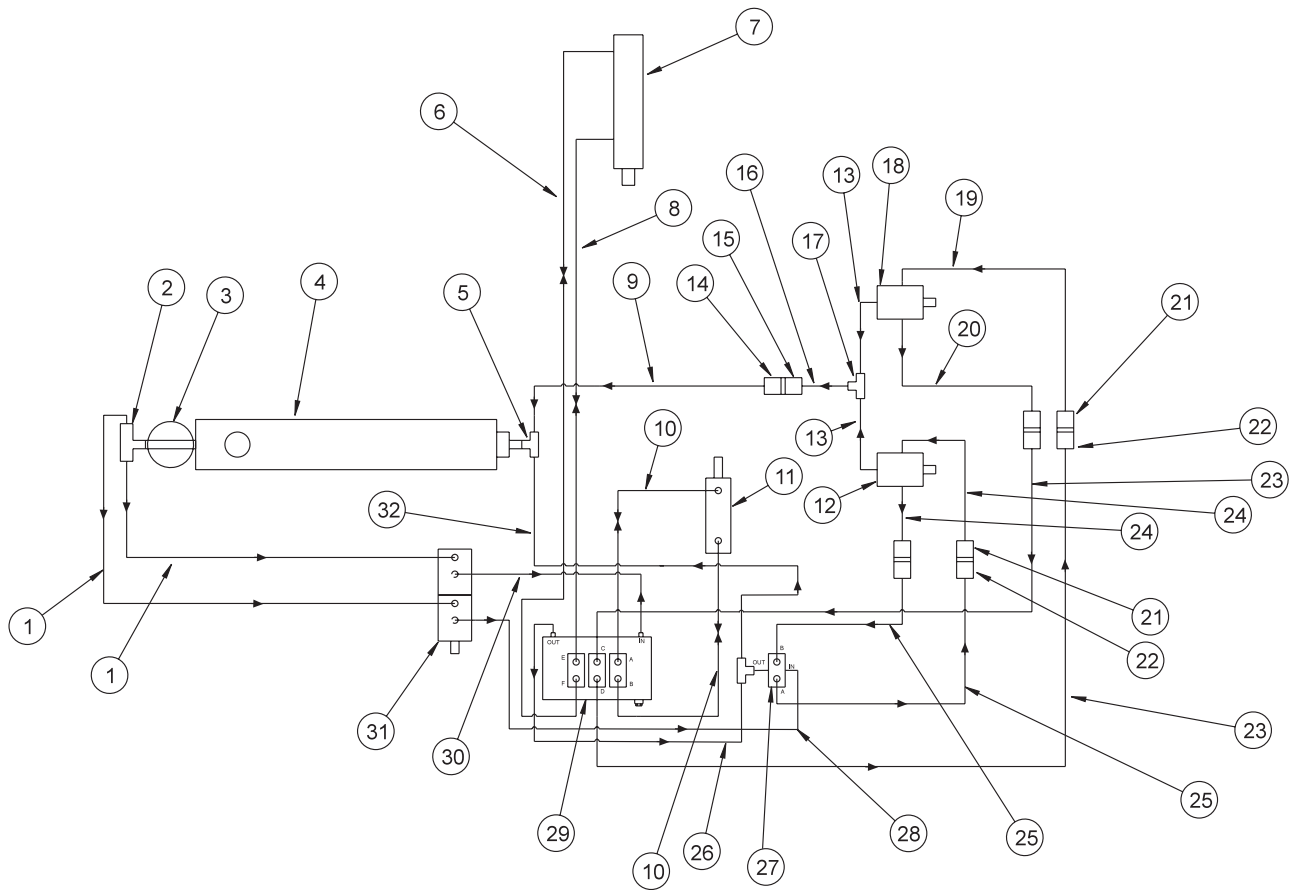

# HYDRAULIC SCHEMATIC

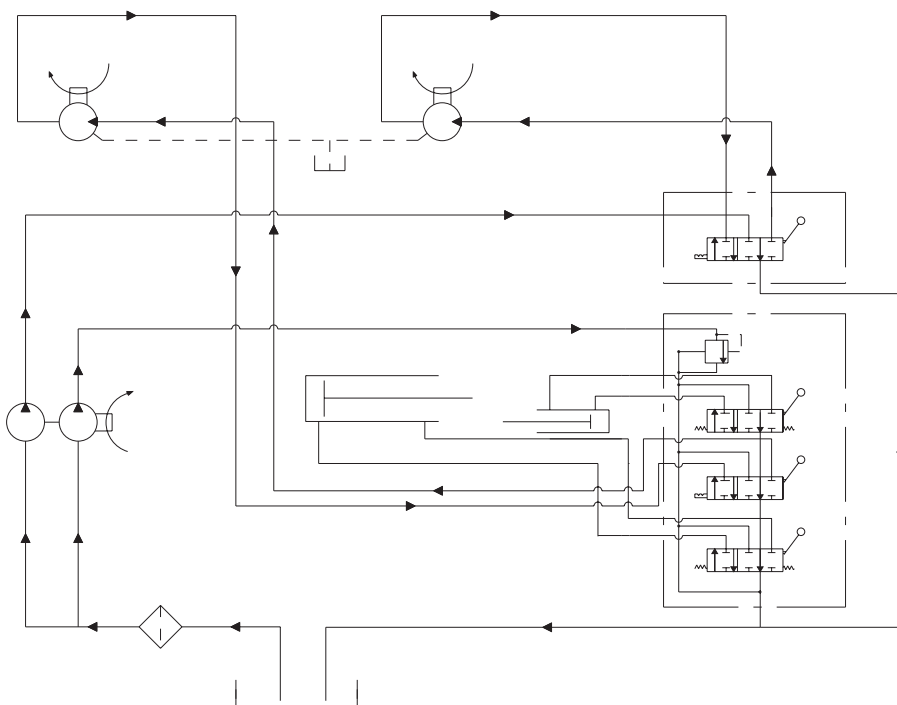

# HYDRAULIC PARTS LIST

REF#	PART#	DESCRIPTION	QUANTITY
1	72-079	Suction Hose	2
2	18-276	Tee Fitting 1 <sup>1</sup> / <sub>4</sub>	1
3	72-146	Filter	1
	60-334	Filter Element (replacement only)	1
4	72-096	Hydraulic Tank	1
5	34-058	Swivel Tee	1
6	72-065	Hydraulic Hose	1
7	72-040	Cylinder	1
	72-040-01	Seal Kit	1
	72-040-02	Pin with Clips (part of 72-040)	2
8	72-064	Hydraulic Hose	1
9	72-070	Hydraulic Hose	1
10	72-071	Hydraulic Hose	2
11	10-187	Hydraulic Cylinder	1
	14-273	Seal Kit	1
12*	72-022	Hydraulic Motor (Thatch Reel)	1
	78-219-01	Seal Kit	1
	78-219-02	Drive Coupler	1
13	72-073	Hydraulic Hose	2
14	72-044	Quick Coupler <sup>3</sup> / <sub>8</sub> Male End	1
15	72-045	Quick Coupler <sup>3</sup> / <sub>8</sub> Female End	1
16	72-072	Hydraulic Hose	1
17	18-170	Tee Fitting	1
18*	78-219	Hydraulic Motor (Reel)	1
	78-219-01	Seal Kit	1
	78-219-02	Drive Coupler	1
19	72-075	Hydraulic Hose	1
20	72-074	Hydraulic Hose	1
21	72-043	Quick Coupler <sup>1</sup> / <sub>2</sub> Male End	4
22	72-046	Quick Coupler <sup>1</sup> / <sub>2</sub> Female End	4
	HRR-150	Retaining Ring 1 <sup>1</sup> / <sub>2</sub> " External	8
23	72-068	Hydraulic Hose	2
24	72-074	Hydraulic Hose	2
25	72-067	Hydraulic Hose	2
26	72-063	Hydraulic Hose	1
27	72-151	Hydraulic Valve	1
28	72-069	Hydraulic Hose	1
29	78-363	Hydraulic 3 Bank Valve	1
30	72-062	Hydraulic Hose	1
31*	72-021	Hydraulic Pump (Double Pump)	1
	72-021-01	Seal Kit	1
32	72-066	Hydraulic Hose	1

\* No other parts are replaceable for hydraulic motor or pump.

## HYDRAULIC PRESSURES

	FRONT	REAR
Pump Displacement	.90 in <sup>3</sup> /rev	.40 in <sup>3</sup> /rev
Pump Input Speed (up to)	4000 rpm	4000 rpm
Max. Operating Pressure	3600 psi	3600 psi
Max. Inlet Vacuum	10 in. Hg	10 in. Hg
Max. Case Pressure	80 psi	80 psi

# BIG VAC MAIN DRAWING

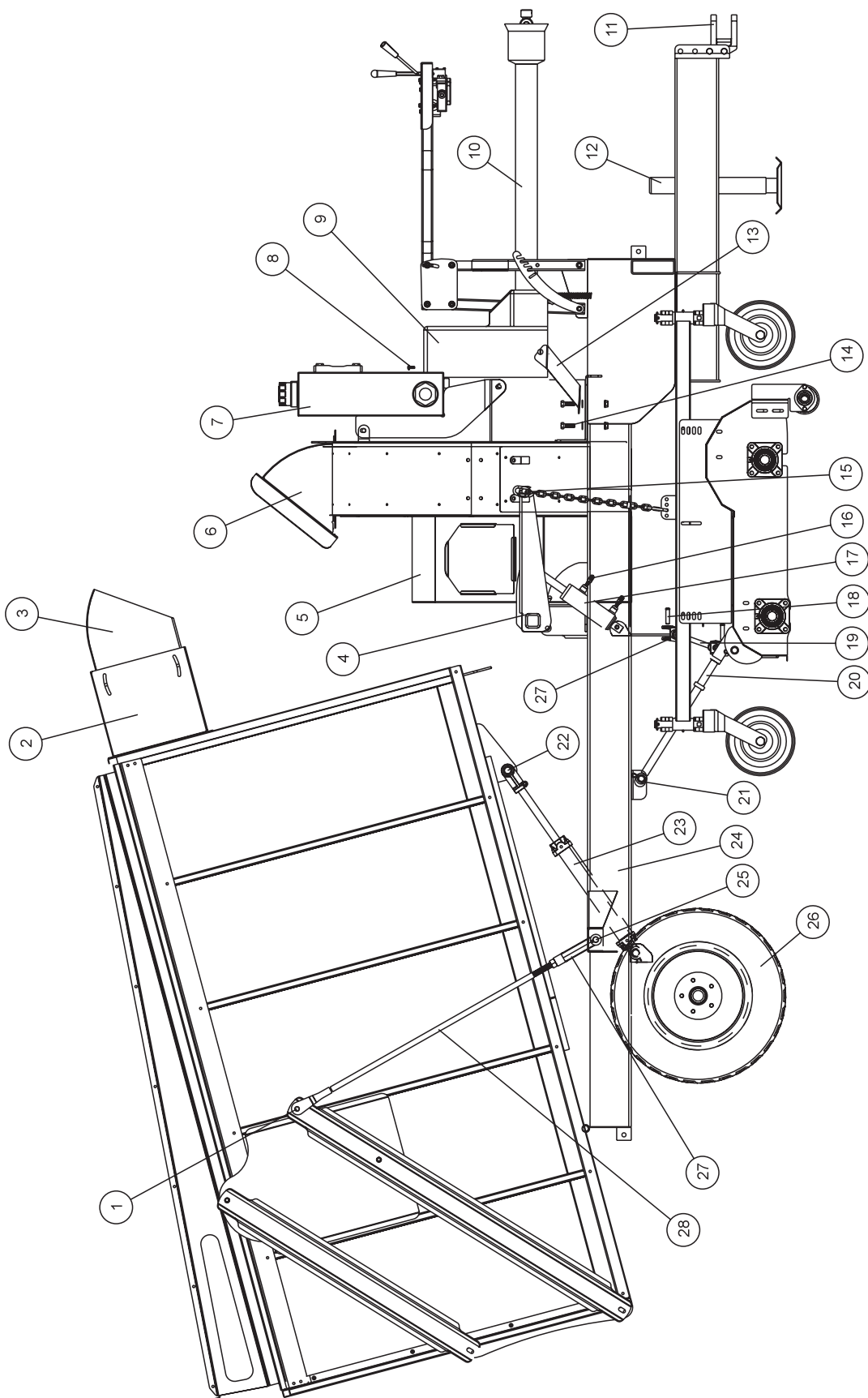

Parts



# BIG VAC MAIN PARTS LIST

REF#	PART#	DESCRIPTION	QUANTITY
1	HCP-12-175	Clevis Pin 1/2 x 1 3/4	2
	HP-18-100	Cotter Pin 1/8 x 1	2
2	72-110	Hopper Chute	1
3	72-111	Middle Chute	1
4	72-108	Reel Lift Cross Bar	1
	HB-12-13-125	Bolt 1/2 - 13 x 1 1/4	2
	HNTL-12-13	Lock Nut 1/2 - 13	2
5	72-081	Vacuum Housing	1
6	72-109	Blower Chute	1
7	72-096	Hydraulic Oil Tank	1
8	HST-516-18-075	Truss Head Machine Screw 5/16 - 18 x 3/4	6
9	72-143	Front PTO Cover	1
	78-274	Cage Nuts	6
10	72-055	PTO Shaft	1
11	78-244	3/4" Clevis	1
12	78-240	Jack	1
13	72-149	Right PTO Cover Bracket	1
	72-150	Left PTO Cover Bracket	1
14	HB-12-13-150	Bolt 1/2 - 13 x 1 1/2	4
	HW-12	Washer 1/2	4
	HNFL-12-13	Flange Whiz Lock Nut 1/2 - 13	4
15	HCP-12-200	Clevis Pin 1/2 x 2	2
	HP-18-100	Cotter Pin 1/8 x 1	2
16	18-169	Adapter	2
17	10-187	Hydraulic Cylinder	1
	14-273	Seal Kit	1
	HCP-12-200	Clevis Pin 1/2 x 2	2
	HP-18-100	Cotter Pin 1/8 x 1	2
18	HCP-34-200	Clevis Pin 3/4 x 2	2
	HP-18-100	Cotter Pin 1/8 x 1	2
19	72-148	Sway Bar	1
20	72-103	Reel Lift Rod	2
21	HCP-100-200	Clevis Pin 1 x 2	4
	HHP-18-100	Bridge Pin 1/8 x 1	4
22	72-040-02	Pin with Clips (part of 72-040)	2
23	72-040	Hydraulic Cylinder	1
	72-040-01	Seal Kit	1
	23-184	Male Connector	2
24	72-080	Main Frame	1
25	HMB-34-10	Machine Bushing 3/4 x 10GA	6
	HP-18-100	Cotter Pin 1/8 x 1	2
26	72-042	Tire and Wheel	2
	33-072-01	Tire W26.5 x 14.00 - 12 4 Ply	2
	72-042-02	Wheel	2
27	42-040	Yoke End	4
	HNJ-34-16	Jam Nut 3/4 - 16	4
28	72-099	Tailgate Lift Rod	2
29	72-177	Hopper Lift Safety	1
	HB-38-16-250	Bolt 3/8 - 16 x 2 1/2	2
	HNW-38-16	Wing Nut 3/8 - 16	2
30	78-365	Adapter with Orifice	1
NS	72-140	Boot (Connects vacuum hosing to reel deck)	1

## NOTE:

Note: if you are using the 72-004 Over-The-Road Towing Package, use 72-159 Tire and Wheel.

# CONTROL PANEL DRAWING

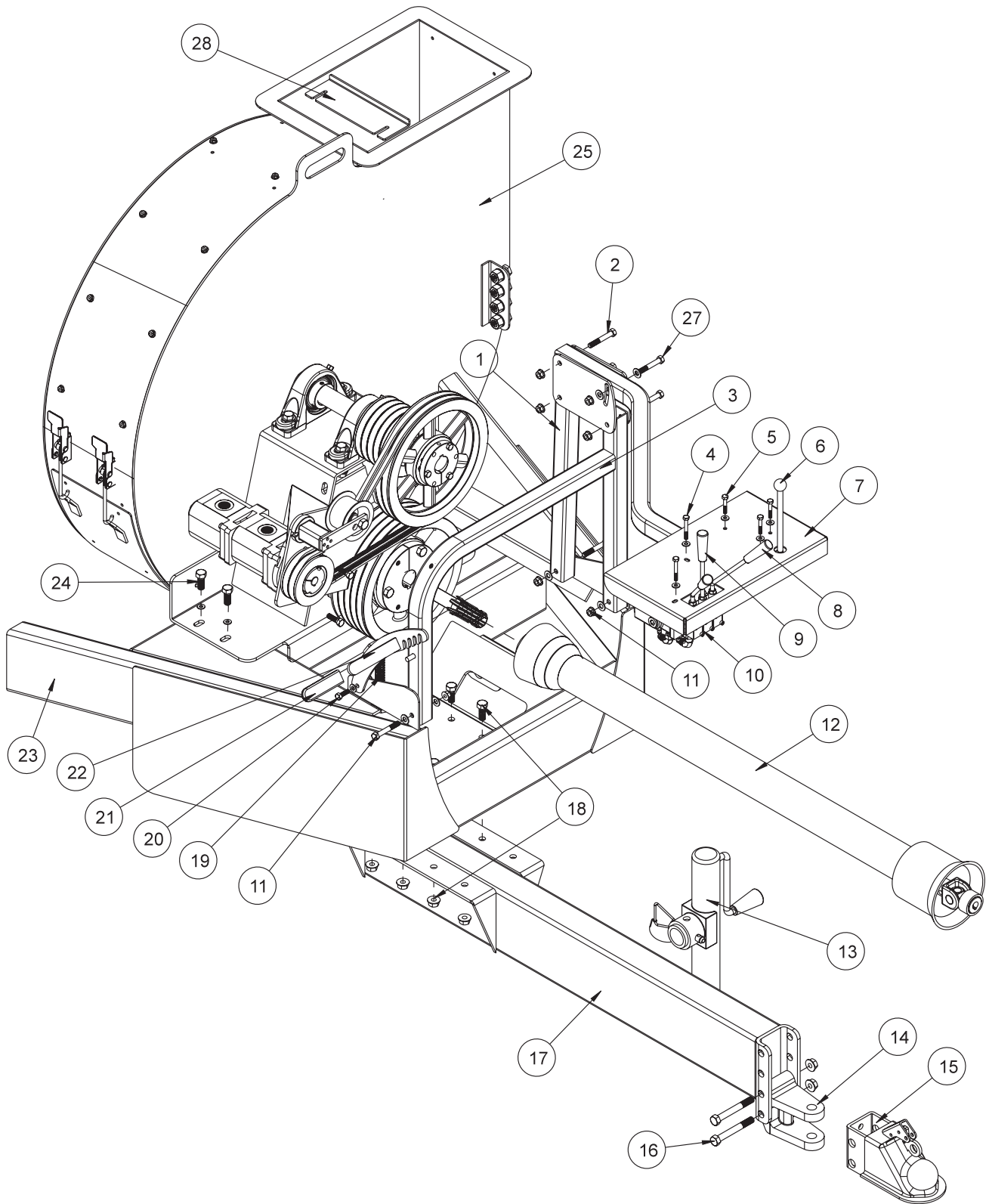

PARTS

# CONTROL PANEL PARTS LIST

REF#	PART#	DESCRIPTION	QUANTITY
1	72-120	Adjustment Leg	1
2	HB-38-16-250	Bolt $\frac{3}{8}$ - 16 x $2\frac{1}{2}$	3
	HNTL-38-16	Lock Nut $\frac{3}{8}$ - 16	3
3	72-121	Control Panel Leg	1
4	HB-14-20-200	Bolt $\frac{1}{4}$ - 20 x 2	2
	HW-14	Washer $\frac{1}{4}$	2
	HNFL-14-20	Flange Whiz Lock Nut $\frac{1}{4}$ - 20	2
5	HB-14-20-150	Bolt $\frac{1}{4}$ - 20 x $1\frac{1}{2}$	3
	HW-14	Washer $\frac{1}{4}$	3
	HNFL-14-20	Flange Whiz Lock Nut $\frac{1}{4}$ - 20	3
6	72-151	Hydraulic Valve	1
7	72-095	Control Panel	1
	72-054	Decal, Control Panel	1
8	42-226	Bent Handle	2
9	42-225	Straight Handle	1
10	78-363	3-Bank Hydraulic Valve	1
11	HB-38-16-250	Bolt $\frac{3}{8}$ - 16 x $2\frac{1}{2}$	3
	HW-38	Washer $\frac{3}{8}$	6
	HNTL-38-16	Lock Nut $\frac{3}{8}$ - 16	3
12	72-055	PTO Shaft	1
13	78-240	Jack	1
14	78-244	$\frac{3}{4}$ Clevis	1
15	78-245	$2\frac{5}{16}$ Ball Hitch (Optional)	1
16	HB-12-13-350	Bolt $\frac{1}{2}$ - 13 x $3\frac{1}{2}$ (comes with 78-244 and 72-245)	2
	HNTL-12-13	Lock Nut $\frac{1}{2}$ - 13 (comes with 78-244 and 72-245)	2
17	72-086	Tongue	1
18	HB-12-13-125	Bolt $\frac{1}{2}$ - 13 x $1\frac{1}{4}$	8
	HNTL-12-13	Lock Nut $\frac{1}{2}$ - 13	8
19	60-323	Spring	1
20	HB-516-18-100	Bolt $\frac{5}{16}$ - 18 x 1	1
	HW-516	Washer $\frac{5}{16}$	2
	HNTL-516-18	Lock Nut $\frac{5}{16}$ - 18	1
21	15-020	Grip	1
22	72-093	Adjustment Lock Arm	1
23	72-080	Main Frame	1
24	HB-12-13-150	Bolt $\frac{1}{2}$ - 13 x $1\frac{1}{2}$	4
	HW-12	Washer $\frac{1}{2}$	4
	HNFL-12-13	Flange Whiz Lock Nut $\frac{1}{2}$ - 13	4
25	72-059	Blower	1
26	72-119	Control Panel Adjustment Bracket	2
27	HB-38-16-275	Bolt $\frac{3}{8}$ - 16 x $2\frac{3}{4}$	1
	HW-38	Washer $\frac{3}{8}$	2
	HNTL-38-16	Lock Nut $\frac{3}{8}$ - 16	1
28	72-175	Lining Holder	1

# OIL TANK DRAWING

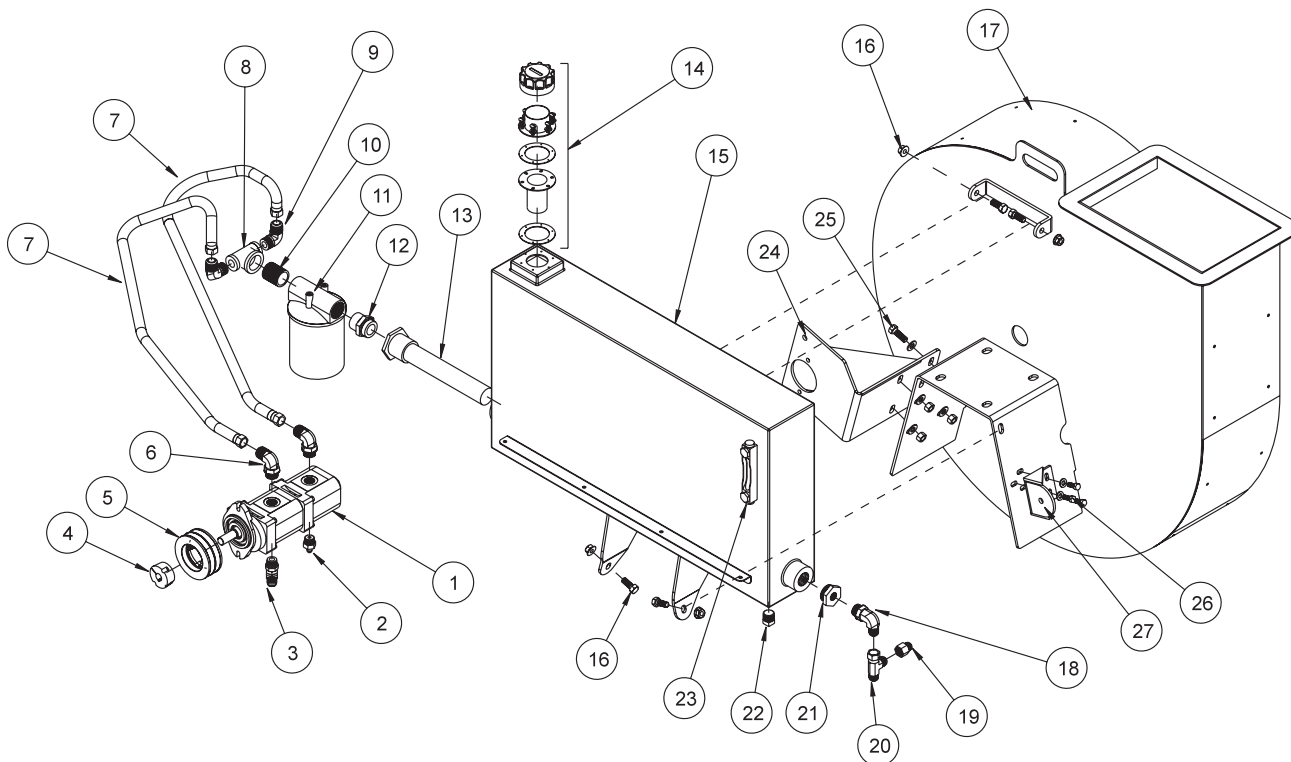

Parts

# OIL TANK PARTS LIST

REF #	PART #	DESCRIPTION	QUANTITY
1†	72-021	Hydraulic Pump	1
	72-021-01	Seal Kit	1
2	18-331	Adapter	1
3	18-265	Elbow	1
4	78-237	Hub	1
	HSSHS-38-16-063	Set Screw $\frac{3}{8}$ -16 x $\frac{5}{8}$ (part of 78-237)	2
	HWK-316-063	Woodruff Key	1
5	72-033	Pulley	1
6	18-346	Elbow	2
7	72-079	Suction Hose	2
8	18-276	Tee	1
9	18-347	Male Elbow	2
10	18-160	Nipple	1
11	72-146	Oil Filter	1
	60-334	Filter Element (Replacement Only)	1
12	18-345	Straight Male Pipe Adapter	1
13*	72-041-01	Suction Strainer	1
14*	72-041-02	Filler / Breather	1
15	72-096	Hydraulic Oil Tank (includes all * items)	1
16	HB-12-13-125	Bolt $\frac{1}{2}$ - 13 x $1\frac{1}{4}$	4
	HNFL-12-13	Flange Whiz Lock Nut $\frac{1}{2}$ -13	4
17	72-059	Blower Housing	1
18	18-204	Elbow	1
19	34-129	Adapter	1
20	34-058	Swivel Tee	1
21	18-315	Reducer Bushing	1
22*	72-041-04	Magnetic Drain Plug	1
23*	72-041-03	Sight Gage	1
24	72-178	Hydraulic Motor Mount	1
25	HB-12-13-150	Bolt $\frac{1}{2}$ - 13 x $1\frac{1}{2}$	4
	HW-12	Washer $\frac{1}{2}$	8
	HNTL-12-13	Lock Nut $\frac{1}{2}$ - 13	4
26	HB-38-16-100	Bolt $\frac{3}{8}$ -16 x 1	3
	HW-38	Washer $\frac{3}{8}$	6
	HNTL-38-16	Lock Nut $\frac{3}{8}$ -16	3
27	72-179	Tensioner Arm	1

† No other parts are replaceable for hydraulic pump

# BLOWER HOUSING DRAWING

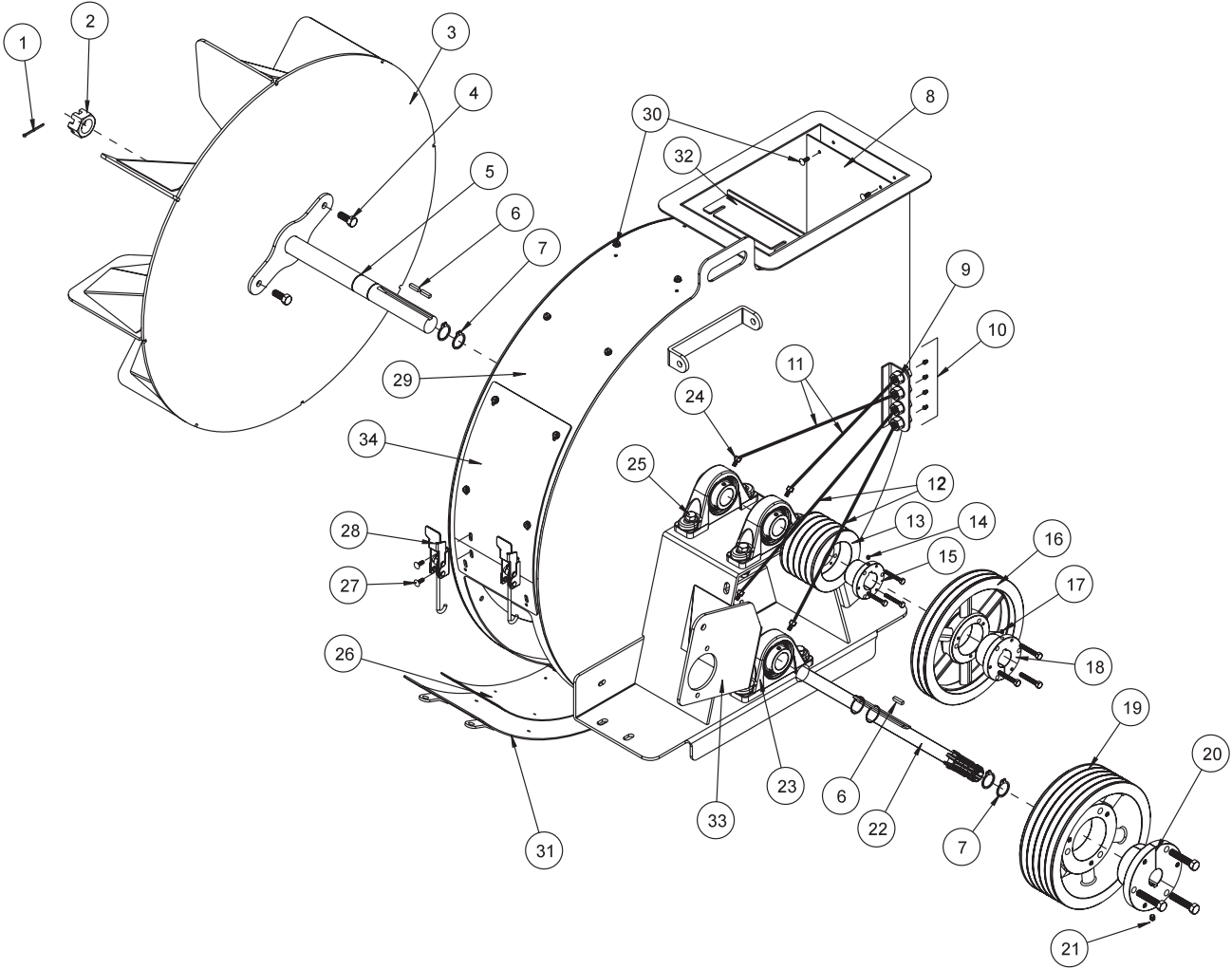

Parts

## BLOWER HOUSING PARTS LIST

REF#	PART#	DESCRIPTION	QUANTITY
1	HP-18-200	Cotter Pin $\frac{1}{8}$ x 2	1
2	HNA-114-12	Axle Nut $1\frac{1}{4}$ - 12	1
3	72-083	Balanced Fan	1
4	HB-12-13-125	Bolt $\frac{1}{2}$ - 13 x $1\frac{1}{4}$	2
	HNTL-12-13	Lock Nut $\frac{1}{2}$ - 13	2
5	72-094	Blower Shaft	1
6	HKSQ-14-100	Square Key $\frac{1}{4}$ x $\frac{1}{4}$ x 1	3
7	HRR-150	Retaining Ring $1\frac{1}{2}$	4
8	72-156	Blower Lining 9 x 62	1
9	18-339	Anchor Coupling	4
	18-338	Male Connector	4
10	HG-18-180	Grease Fitting $\frac{1}{8}$ x 180°	4
11	72-126	Brake Line $\frac{3}{16}$ x 24	2
12	72-127	Brake Line $\frac{3}{16}$ x 30	2
13	72-029	Pulley	1
14	HSSHS-14-20-025	Set Screw $\frac{1}{4}$ - 20 x $\frac{1}{4}$ (comes with 72-030)	1
15	72-030	Hub	1
16	72-027	Pulley	1
17	HSSHS-14-20-025	Set Screw $\frac{1}{4}$ - 20 x $\frac{1}{4}$ (comes with 72-028)	1
18	72-028	Hub	1
19	72-031	Pulley	1
20	72-032	Hub	1
21	HSSHS-38-16-038	Set Screw $\frac{3}{8}$ - 16 x $\frac{3}{8}$ (comes with 72-032)	1
22	72-060	Keyed PTO Shaft	1
23	72-024	Pillow Blocks	4
24	18-338	Male Connector	4
25	HB-58-11-250	Bolt $\frac{5}{8}$ - 11 x $2\frac{1}{2}$	8
	HMB-34-10	Machine Bushing $\frac{3}{4}$ x 10GA	4
	HW-58	Washer $\frac{5}{8}$	8
	HNTL-58-11	Lock Nut $\frac{5}{8}$ - 11	8
26	72-158	Trap Door Lining	1
27	HSTP-14-20-075	Phillip Head Machine Screw $\frac{1}{4}$ - 20 x $\frac{3}{4}$	4
	HNFL-14-20	Flange Whiz Lock Nut $\frac{1}{4}$ - 20	4
28	48-115	Adjustable Draw Latch	2
29	72-059	Blower Housing	1
	72-157	Blower Lining 9 x 41	1
30	HSTP-14-20-075	Phillip Head Machine Screw $\frac{1}{4}$ - 20 x $\frac{3}{4}$	44
	HWF-14-150	Fender Washer, $\frac{1}{4}$ x $1\frac{1}{2}$	44
	HNFL-14-20	Flange Whiz Lock Nut $\frac{1}{4}$ - 20	44
31	72-174	Blower Housing Access Door	1
	HRS-316-075	Rivet $\frac{3}{16}$ x $\frac{3}{4}$	3
32	72-175	Lining Holder	1
33	72-178	Hydraulic Motor Mount	1
	HB-12-13-150	Bolt $\frac{1}{2}$ - 13 x $1\frac{1}{2}$	4
	HW-12	Washer $\frac{1}{2}$	8
	HNTL-12-13	Lock Nut $\frac{1}{2}$ - 13	4
34	72-184	Wear Cover	1

# VACUUM HOUSING, BELTS AND TENSIONER DRAWING

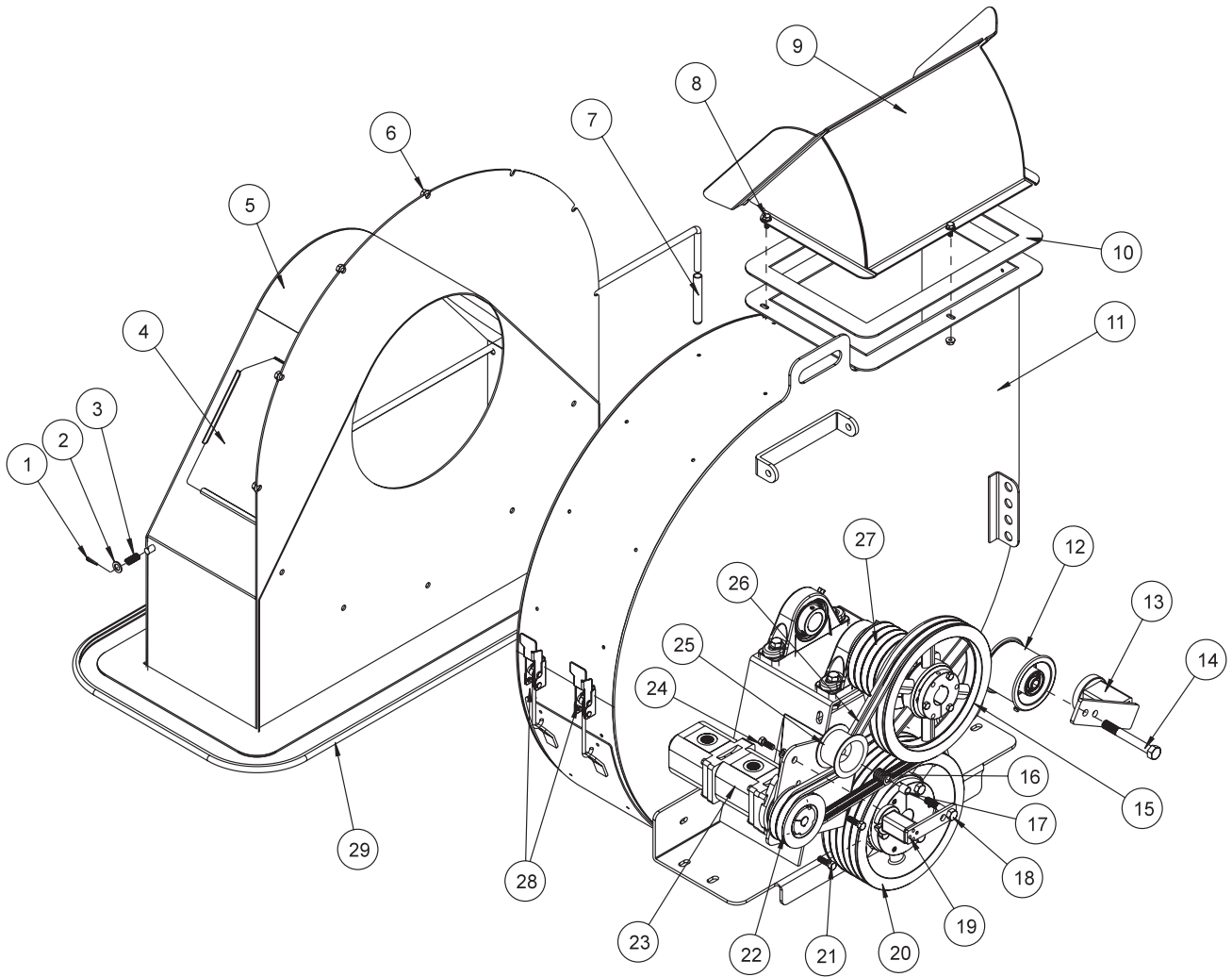

Parts



# VACUUM HOUSING, BELTS AND TENSIONER PARTS LIST

REF#	PART#	DESCRIPTION	QUANTITY
1	HP-18-100	Cotter Pin $\frac{1}{8}$ x 1	1
2	HMB-12-14	Machine Bushing $\frac{1}{2}$ x 14GA	1
3	72-132	Spring	1
4	78-293	Cover Plate	2
5	72-081	Vacuum Housing	1
6	HNFL-38-16	Flange Whiz Lock Nut $\frac{3}{4}$ -16	12
	HBFL-38-16-075	Flange Bolt $\frac{3}{8}$ - 16 x $\frac{3}{4}$	12
7	25-120	Handle Grip	1
8	HBFL-516-18-075	Flange Bolt $\frac{5}{16}$ -18 x $\frac{3}{4}$	3
	HNFL-516-18	Flange Whiz Lock Nut $\frac{5}{16}$ - 18	3
9	72-109	Blower Chute	1
	72-131	Blower Chute Lining 10 $\frac{1}{2}$ x 15 $\frac{1}{2}$	1
	HSTP-14-20-075	Phillip Head Machine Screw $\frac{1}{4}$ -20 x $\frac{3}{4}$	6
	HNFL-14-20	Flange Whiz Lock Nut $\frac{1}{4}$ - 20	6
10	8828-60	Foam Tape	1
11	72-059	Blower Housing	1
12	72-050	Idler Pulley	1
13	72-147	Tensioner	1
	HBM-12-1.75-40	Metric Bolt 12 - 1.75 x 40 (comes with 72-025)	1
	HWLM-12	Metric Lockwasher 12 (comes with 72-025)	1
14	HB-58-11-500	Bolt $\frac{5}{8}$ - 11 x 5	1
	HNCL-58-11	Center Lock Nut $\frac{5}{8}$ - 11	1
15	72-027	Pulley	1
	72-028	Hub	1
16	HMB-12-14	Machine Bushing $\frac{1}{2}$ x 14GA	6
17	76-275	Spacer (comes with 78-224)	1
18	HB-12-13-250	Bolt $\frac{1}{2}$ - 13 x 2 $\frac{1}{2}$ (comes with 78-224)	1
	HNCL-12-13	Center Lock Nut $\frac{1}{2}$ - 13 (comes with 78-224)	1
19	78-224	Tensioner	1
20	72-031	Pulley	1
	72-032	Hub	1
21	HB-38-16-125	Bolt $\frac{3}{8}$ - 16 x 1 $\frac{1}{4}$	2
	HNFL-38-16	Flange Whiz Lock Nut $\frac{3}{8}$ - 16	2
22	72-033	Pulley	1
	78-237	Hub	1
23	72-021	Hydraulic Pump	1
24	HBM-10-1.50-30	Metric Bolt 10 - 1.5 x 30 (comes with 78-224)	1
	HWLM-10	Metric Lockwasher 10 (comes with 78-224)	1
25	16-013	Idler Pulley	1
26	72-036	Belt 5V x 540	2
27	72-029	Pulley	1
	72-030	Hub	1
	72-036	Belt 5V x 540	5
28	48-115	Draw Latch	2
29	8803-114	Trim Black	1

# HOPPER DRAWING

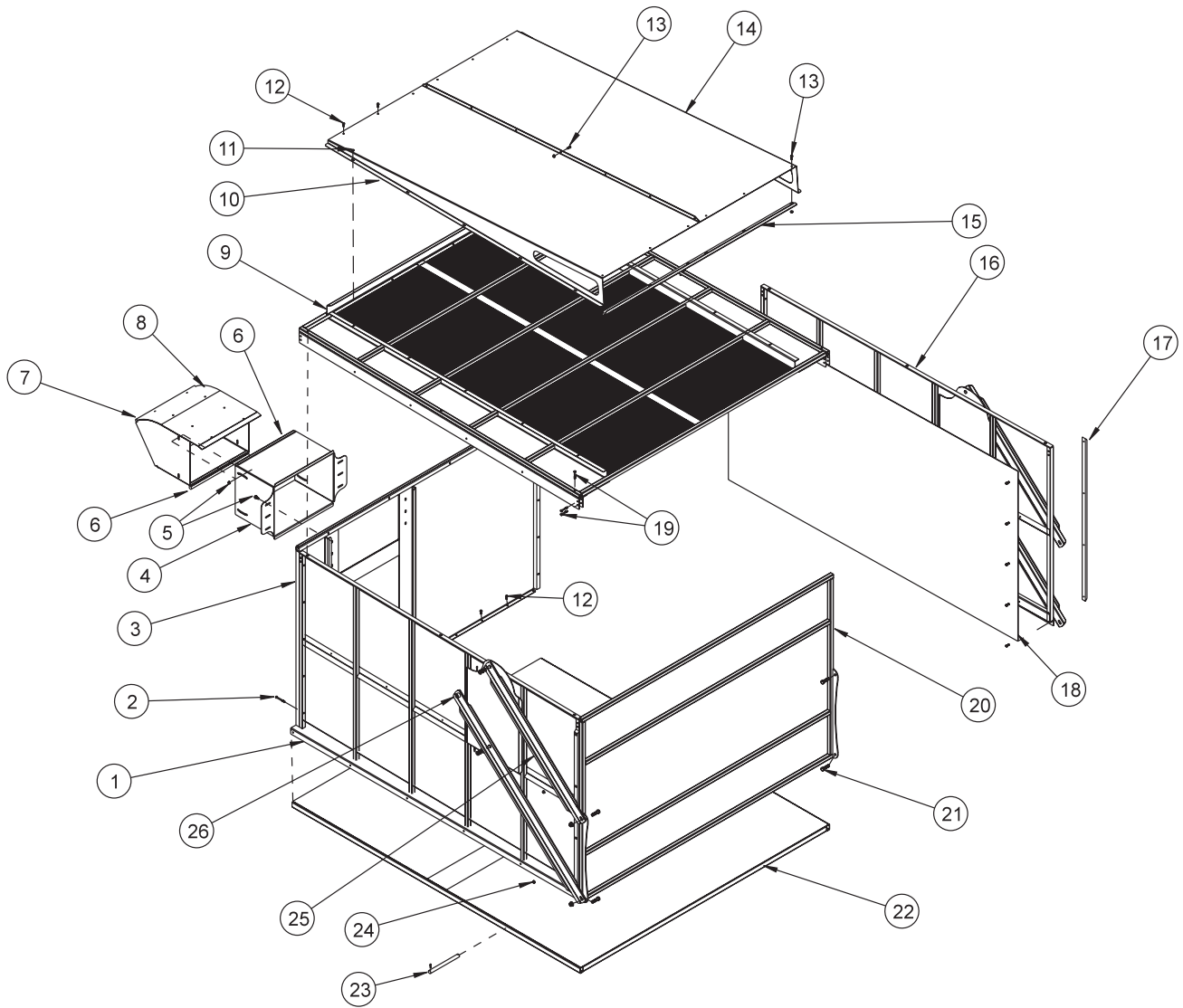

Parts

# HOPPER PARTS LIST

REF #	PART #	DESCRIPTION	QUANTITY
1	72-106	Left Hopper Side Frame	1
2	HB-14-20-250	Bolt 1/4 -20 x 2 1/2	15
	HNFL-14-20	Flange Whiz Lock Nut 1/4 -20	15
3	72-115	Hopper Front	1
	HSDPS-14-075	Stainless Pan Head Drill Screw 1/4 x 3/4	9
4	72-110	Hopper Chute	1
	72-145	Hopper Chute Lining	1
	HSTP-14-20-075	Phillip Head Machine Screw 1/4 -20 x 3/4	6
	HNFL-14-20	Flange Whiz Lock Nut 1/4 - 20	6
5	HBFL-516-18-075	Flange Bolt 5/16 -18 x 3/4	10
	HNFL-516-18	Flange Whiz Lock Nut 5/16 -18	10
6	8947-18	Trim Seal	2
7	8980-60	Edge Seal	1
8	72-111	Middle Chute	1
9	72-107	Hopper Top	1
10	72-102	Left Hopper Cover	1
11	HW-14	Washer 1/4	10
12	HSDPS-14-075	Stainless Pan Head Drill Screw 1/4 x 3/4	6
13	HB-14-20-075	Bolt 1/4 -20 x 3/4	23
	HNFL-14-20	Flange Whiz Lock Nut 1/4 -20	23
14	72-101	Right Hopper Cover	1
15	72-124	Hood Stiffener	1
16	72-105	Right Hopper Side Frame	1
17	72-138	Slide Strip	2
	HRS-316-075	Pop Rivet 3/16	8
18	72-137	Hopper Side	2
	HSDPS-14-075	Stainless Pan Head Drill Screw 1/4 x 3/4	82
19	HB-14-20-175	Bolt 1/4 -20 x 1 3/4	14
	HNFL-14-20	Flange Whiz Lock Nut 1/4 - 20	14
20	72-116	Tailgate	1
21	HB-12-13-175	Bolt 1/2 -13 x 1 3/4	4
	HNFL-12-13	Flange Whiz Lock Nut 1/2 - 13	4
22	72-098	Hopper Floor	1
23	72-123	Pivot Pin	2
	HP-18-100	Cotter Pin 1/8 x 1	4
24	HSTP-14-20-075	Phillip Head Machine Screw 1/4 -20 x 3/4	18
	HNFL-14-20	Flange Whiz Lock Nut 1/4 - 20	18
25	72-118	Short Tailgate Lift Arm	2
	18-235	Bushing (part of 72-118)	1
	HMB-12-14	Machine Bushing 1/2 x 14 GA	6
	HP-18-100	Cotter Pin 1/8 x 1	2
26	72-117	Long Tailgate Lift Arm	2
	18-235	Bushing (part of 72-117)	2
	HMB-12-14	Machine Bushing 1/2 x 14 GA	6
	HP-18-100	Cotter Pin 1/8 x 1	2

# 72-151 HYDRAULIC VALVE DRAWING

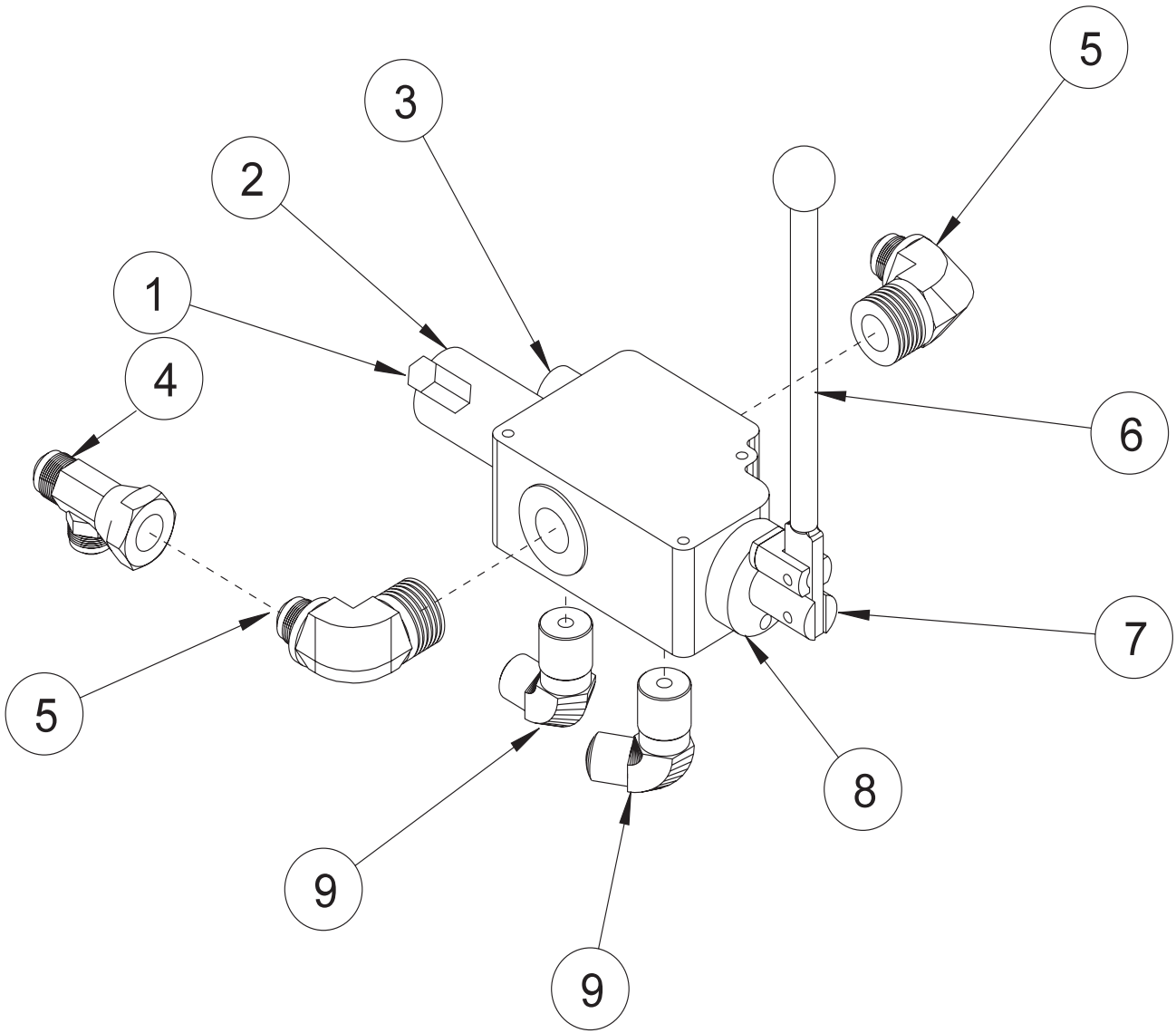

Parts

## 72-151 HYDRAULIC VALVE PARTS LIST

REF#	PART#	DESCRIPTION	QUANTITY
1*	33-066-27	Detent Housing	1
	33-066-17	Detent Plunger	1
	33-066-29	Spring	1
	33-066-19	Set Screw $5/16 - 24 \times 3/8$	1
	33-066-18	Washer	1
2*	33-066-20	Detent End Cap	1
	33-066-22	Spacer	1
	33-066-25	Washer	2
	33-066-23	Spacer	1
	33-066-28	Spacer, Spool	1
	33-066-21	Center Spring	1
	33-066-26	Sleeve	1
	33-066-24	Bolt $5/16 - 18 \times 2 1/2$	1
	3*	33-066-11	Cap Nut
33-066-04		Washer	1
33-066-10		Adjustment Screw	1
33-066-09		Poppet	1
33-066-03		Spring	1
4	18-337	Run Tee	1
5	18-244	Male Elbow	2
6*	72-151-01	Valve Handle Kit	1
	33-066-08	Ball Knob	1
7*	33-066-02	Spool	1
	33-066-05	Quad Ring	2
	33-066-06	Wiper	2
8*	33-066-15	Clevis Bracket	1
9	18-246	Male Elbow	2
*	72-151	Hydraulic Valve, 2800 psi, 190 Bars (includes all * items)	

# 78-363 3-BANK HYDRAULIC VALVE DRAWING

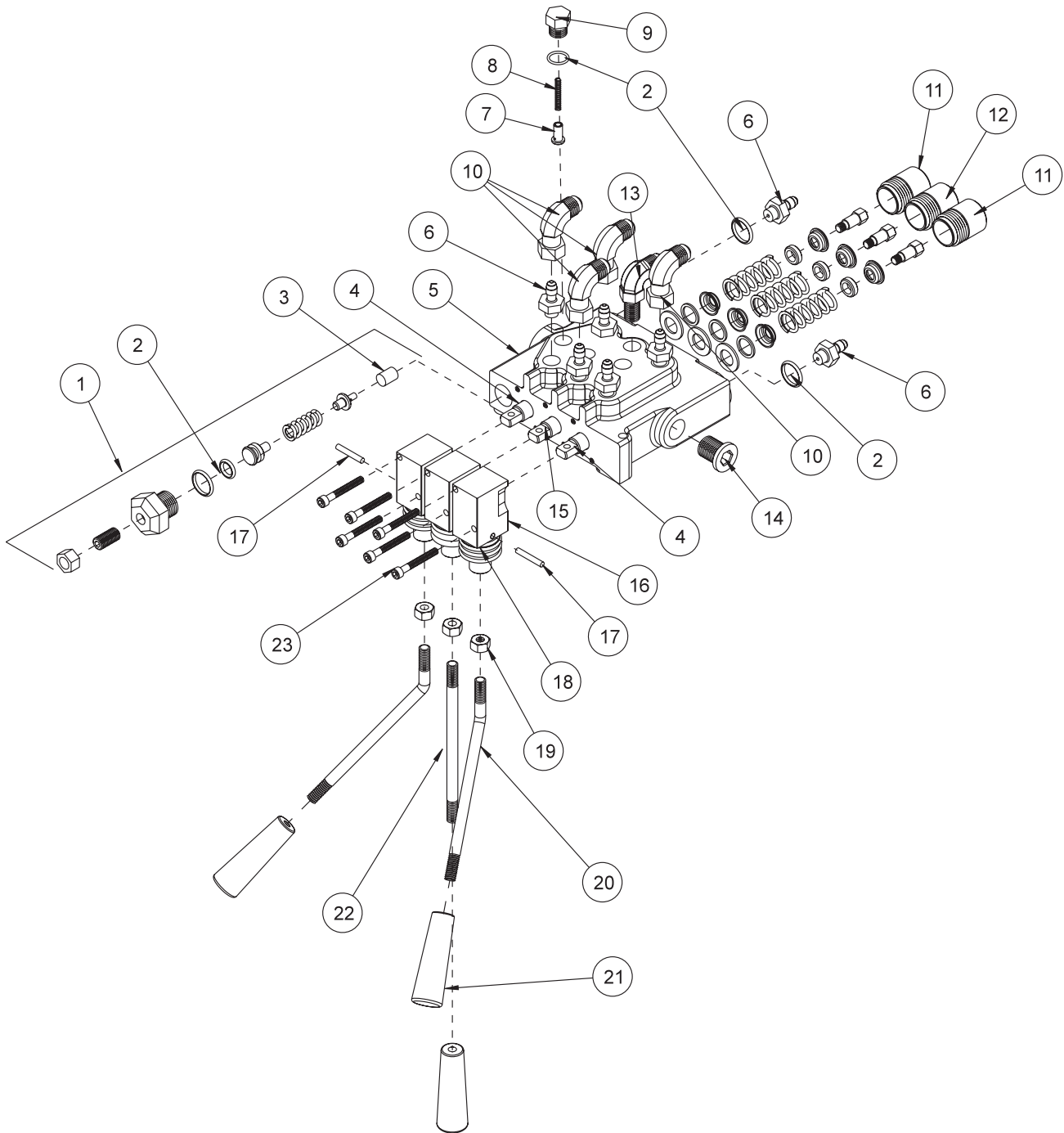

Parts

## 78-363 3-BANK HYDRAULIC VALVE PARTS LIST

REF#	PART#	DESCRIPTION	QUANTITY
1*	14-106	Relief Assembly Kit	1
2*	14-205	Seal Kit	1
3*	13-261-03	N.R. Plug	1
4*	14-088	Spool	2
5*	42-227-01	3-Bank Housing	1
6	18-169	Adapter <sup>3</sup> / <sub>8</sub> SAE	7
7*	13-261-07	Plunger	3
8*	13-261-06	Spring	3
9*	13-261-05	Plug	3
10	18-202	Elbow	4
11*	14-203	Spring Centered Kit	2
12*	78-306-02	Two Spring Detent Kit	1
13	18-168	Elbow <sup>3</sup> / <sub>8</sub> Straight Thread	1
14*	13-261-02	Plug	1
15*	78-306-03	Spool Stem (reel bank)	1
16*	42-220-04	Actuator Housing	3
17*	42-220-05	Dowel Pin	3
18*	42-220-03	Actuator Link	3
19	HNJ-516-18	Jam Nut <sup>5</sup> / <sub>16</sub> – 18 (part of 42-226 or 42-225)	3
20	42-226	Bent Handle (includes Ref 19 and 21)	2
21	42-220-08	Tapered Knob (part of 42-226 or 42-225)	3
22	42-225	Straight Handle (includes Ref 19 and 21)	1
23*	42-220-06	Socket Head Cap Screw 10 – 32 x 1 <sup>1</sup> / <sub>2</sub>	6

\*                    78-363                    3 – Bank Hydraulic Valve (includes all \* items)

# 72-048 AXLE DRAWING

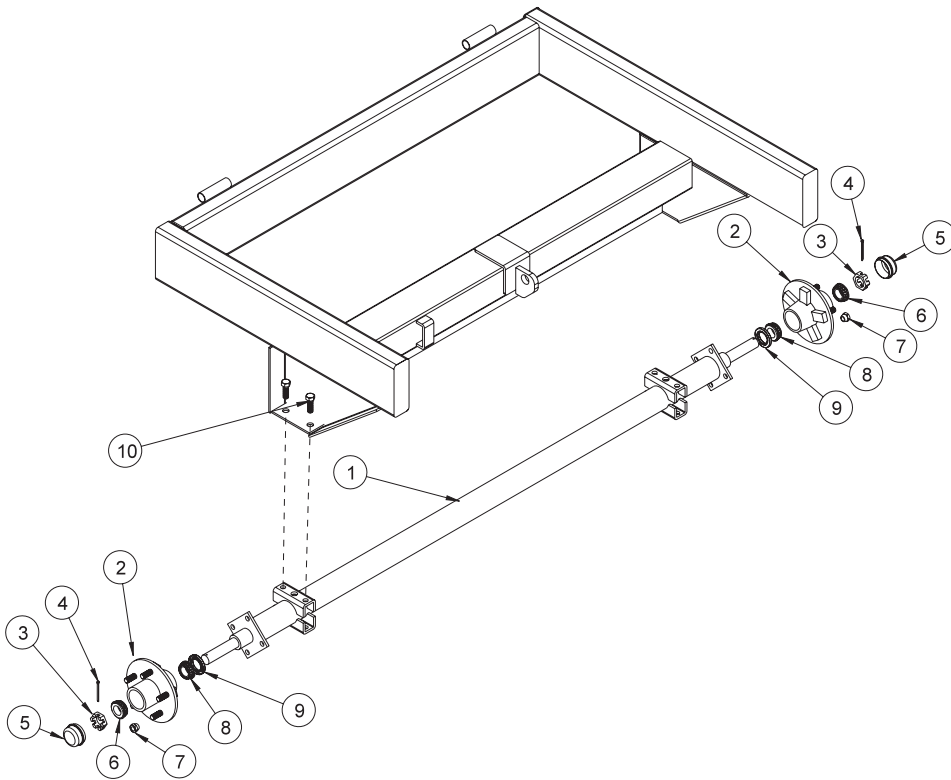

# 72-055 PTO SHAFT DRAWING

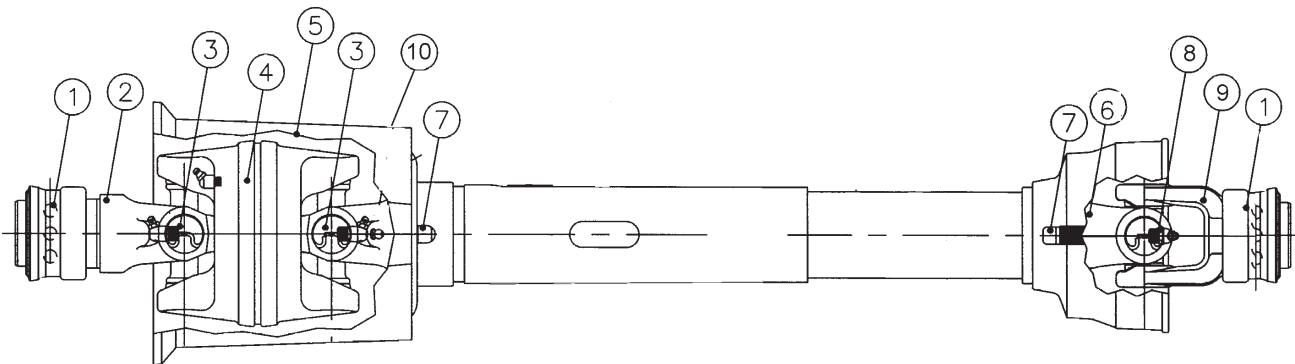

Parts



## 72-048 AXLE PARTS LIST

REF #	PART #	DESCRIPTION	QUANTITY
1	72-048	Axle (includes all items listed below except #10)	1
2	33-073	Hub Assembly (includes all * items listed below)	2
3	HNAR-100-14	Slotted Jam Nut 1-14	2
4	HP-18-200	Cotter Pin 1/8 x 2	2
5*	33-073-02	Dust Cap	2
6*	78-119	Outer Bearing	2
7*	HNL-12-20	Lug Nut	10
8*	78-118	Inter Bearing	2
9*	33-073-01	Grease Seal	2
10	HB-12-13-125	Bolt 1/2 - 13 x 1 1/4	4
	HNTL-12-13	Lock Nut 1/2 - 13	4

### **NOTE:**

NOTE: If using the 72-004 Over-The-Road Towing Package, order Hub Assembly Part Number 72-162. Seals, bearings and cap are the same part numbers.

## 72-055 PTO SHAFT PARTS LIST

REF#	PART#	DESCRIPTION	QUANTITY
1	72-055-01	Spring - Lok Repair Kit	2
2	72-055-02	Spring - Lok Yoke Assembly	1
3	72-055-03	Cat, 3 Cross and Bearing Kit	2
4	72-055-04	CV Center Housing Assembly	1
5	72-055-05	Bell Extension with Nylon Centralizer	1
6	72-055-07	Yoke, Tube and Slip Sleeve	1
7	72-055-06	Nylon Repair Kit	2
8	72-055-08	14R Cross and Bearing Kit	1
9	72-055-09	Spring - Lok Yoke Assembly	1

# 72-001 COMBINATION SWEEPER - VERTICUT HEAD DRAWING

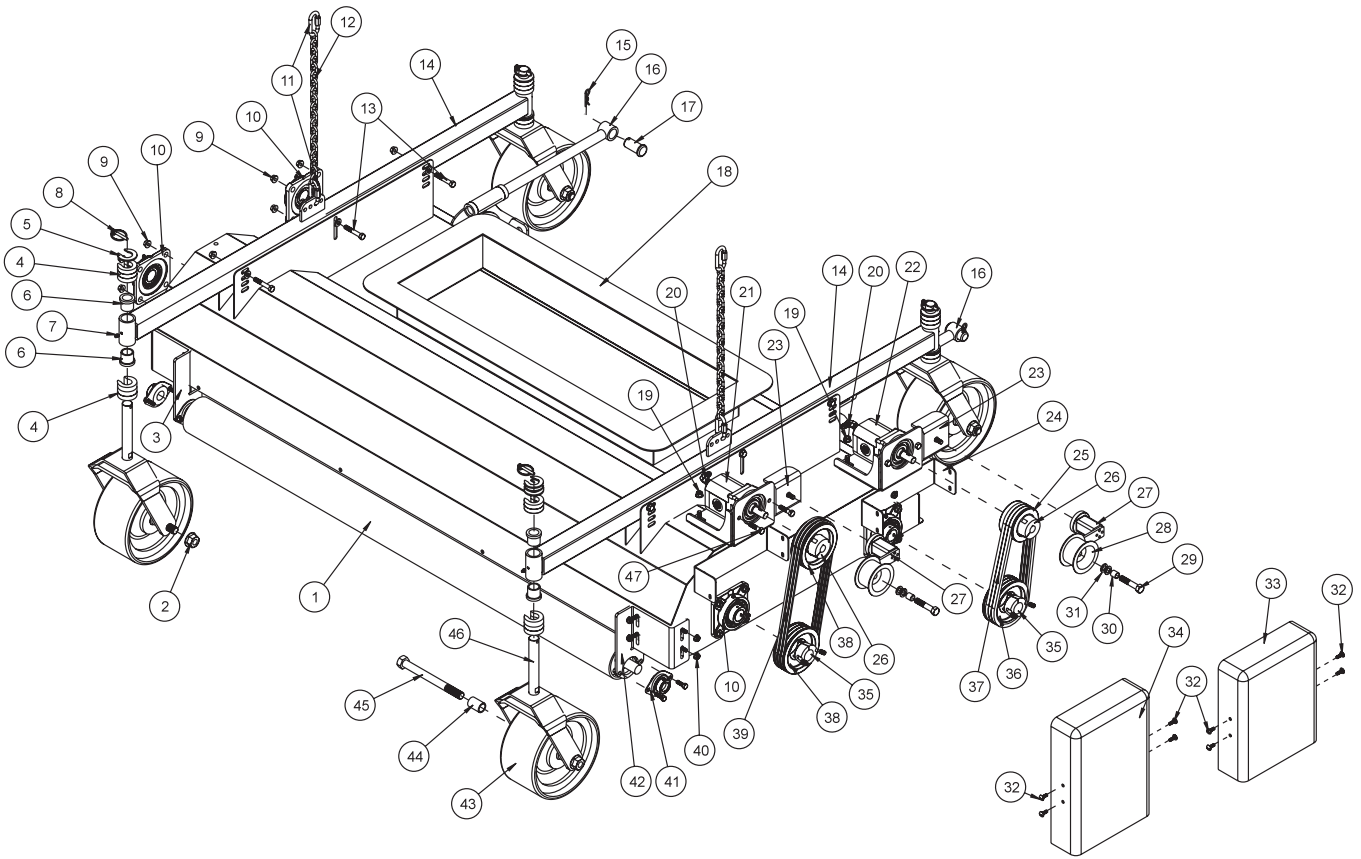

ACCESSORIES

## 72-001 COMBINATION SWEEPER - VERTICUT HEAD PARTS LIST

REF#	PART#	DESCRIPTION	QUANTITY
1	72-090	Anti-Scalp Roller	1
2	HNTL-34-10	Top Lock Nut $\frac{3}{4}$ - 10	4
3	72-114	Left Roller Bracket	1
4	72-053	Quick Spacer $\frac{1}{2}$ "	20
5	72-136	Quick Spacer 10GA	12
6	18-223	Flange Bushing (part of 72-112)	8
7	HG-14-28-180	Grease Fitting $\frac{1}{4}$ - 28 x 180° (part of 72-112)	4
8	42-539	Lynch Pin $\frac{5}{16}$	4
9	HB-38-16-125	Bolt $\frac{3}{8}$ -16 x 1 $\frac{1}{4}$	16
	HNFL-38-16	Flange Whiz Lock Nut $\frac{3}{8}$ - 16	16
10	72-023	Flange Bearing	4
	HG-14-28-180	Grease Fitting $\frac{1}{4}$ - 28 x 180° (part of 72-023)	4
11	72-100	$\frac{5}{16}$ Chain Connector	4
12	8820-19	Machine Chain Straight Link	2
13	HB-38-16-275	Bolt $\frac{3}{8}$ -16 x 2 $\frac{3}{4}$	6
	HW-38	Washer $\frac{3}{8}$	6
	HNFL-38-16	Flange Whiz Lock Nut $\frac{3}{8}$ -16	6
14	72-112	Castor Wheel Arm	2
15	HHP-18-100	Bridge Pin $\frac{1}{8}$ x 1 (2 are part of machine)	4
16	72-103	Reel Lift Rod (part of machine)	2
17	HCP-100-200	Clevis Pin 1 x 2 (2 are part of machine)	4
18	72-085	Reel Housing	1
	8803-114	Trim Black with Lace	1
19	HB-38-16-100	Bolt $\frac{3}{8}$ -16 x 1	8
	HW-38	Washer $\frac{3}{8}$	8
	HNFL-38-16	Flange Whiz Lock Nut $\frac{3}{8}$ -16 x 1	8
20	18-168	Elbow	2
21†	72-022	Hydraulic Motor (thatcher reel)	1
	HWK-316-063	Woodruff Key $\frac{3}{16}$ x $\frac{5}{8}$	1
22†	78-219	Hydraulic Motor (finger reel)	1
	HWK-316-063	Woodruff Key $\frac{3}{16}$ x $\frac{5}{8}$	1
23	72-097	Motor Mount	2
24	72-058	Belt Guard Mount	2
	HB-516-18-075	Bolt $\frac{5}{16}$ - 18 x $\frac{3}{4}$	4
	HW-516	Washer $\frac{5}{16}$	4
	HNFL-516-18	Flange Whiz Lock Nut $\frac{5}{16}$ - 18	4
25	78-232	Pulley	1
26	78-237	$\frac{3}{4}$ " Hub	2
27	78-224	Belt Tensioner	2
	HBM-10-1.50-30	Metric Bolt 10 - 1.5 x 30 (comes with 78-224)	1
	HWLM-10	Metric Lockwasher 10 (comes with 78-224)	1
28	16-013	Idler Pulley	2
29	HB-12-13-250	Bolt $\frac{1}{2}$ - 13 x 2 $\frac{1}{2}$ (part of 78-224)	2
	HNCL-12-13	Center Lock Nut $\frac{1}{2}$ - 13 (part of 78-224)	2
30	76-275	Spacer (part of 78-224)	2

(Continued on next page)

†	78-219-01	Seal kit	1 per
	78-219-02	Driver Coupler	1 per
	HWK-316-063	Woodruff Key $\frac{3}{16}$ x $\frac{5}{8}$	1 per

**No other parts are replaceable for hydraulic motors.**

# 72-001 COMBINATION SWEEPER - VERTICUT HEAD DRAWING

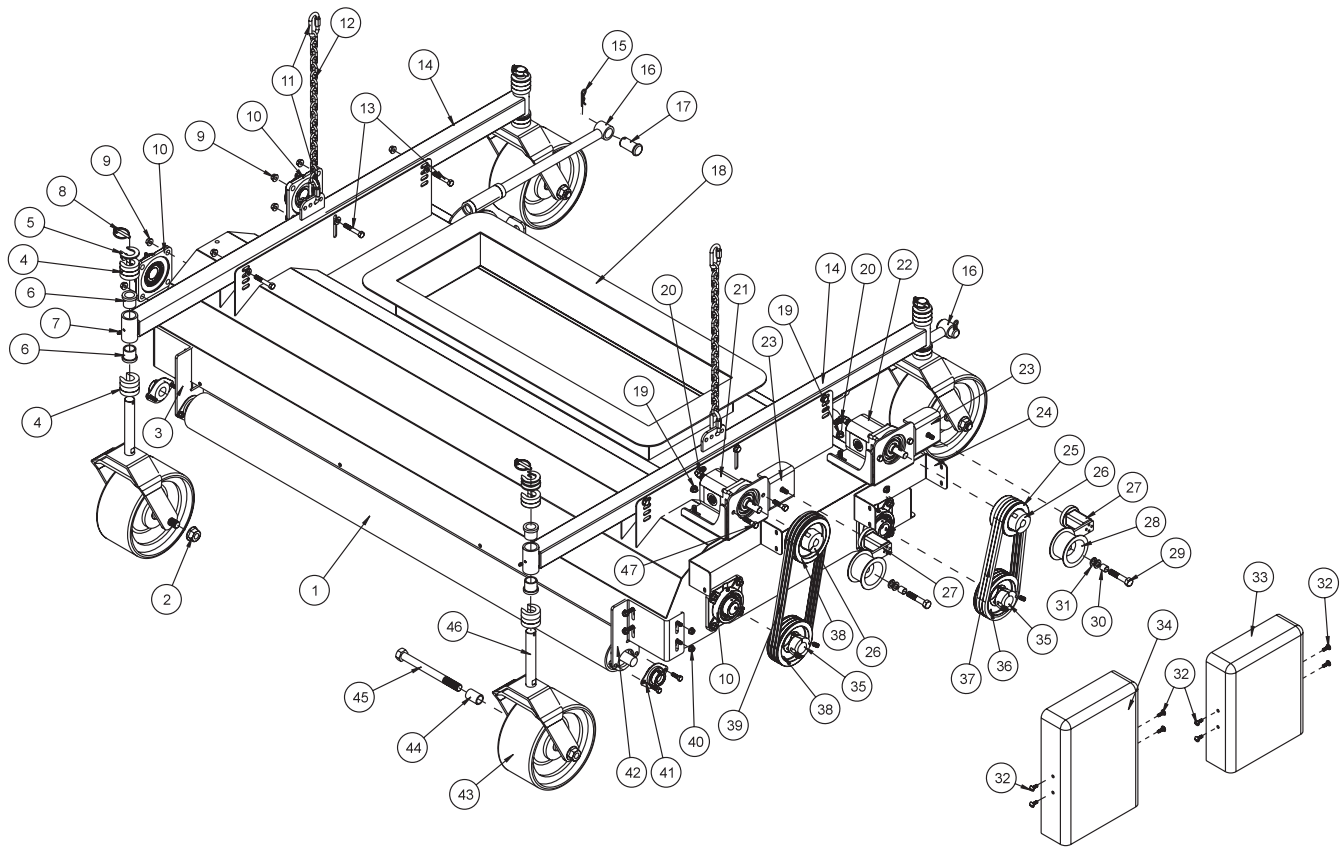

Accessories

## 72-001 COMBINATION SWEEPER - VERTICUT HEAD PARTS LIST

REF#	PART#	DESCRIPTION	QUANTITY
31	HMB-12-14	Machine Bushing 1/2 x 14GA	4
32	HSTP-14-20-075	Phillip Machine Screw 1/4 - 20 x 3/4	8
	HNFL-14-20	Flange Whiz Lock Nut 1/4 - 20	8
33	72-056	Belt Guard 13"	1
34	72-057	Belt Guard 15"	1
35	72-035	1 1/4 Hub	2
36	78-233	Pulley	1
37	72-038	Belt	3
38	72-034	Pulley	2
39	72-037	Belt	3
40	HB-516-18-075	Bolt 5/16 - 18 x 3/4	8
	HW-516	Washer 5/16	8
	HNFL-516-18	Flange Whiz Lock Nut 5/16 - 18	8
41	13-391	1" Flange Bearing	2
	HB-516-18-100	Bolt 5/16 - 18 x 1	4
	HWL-516	Lockwasher 5/16	4
	HN-516-18	Nut 5/16 - 18	4
42	72-113	Right Roller Bracket	1
43	78-012	Tire and Wheel	4
	78-012-01	Bearing (part of 78-012)	4
44	72-135	Castor Wheel Spacer	8
45	HB-34-10-800	Bolt 3/4 - 10 x 8	4
46	72-134	Castor Fork	4
47	HB-38-16-125	Bolt 3/8 - 16 x 1 1/4	4
	HW-38	Washer 3/8	4
	HNTL-38-16	Lock Nut 3/8 - 16	4

*(Continued on next page)*

# 72-001 COMBINATION SWEEPER - VERTICUT REEL DRAWING

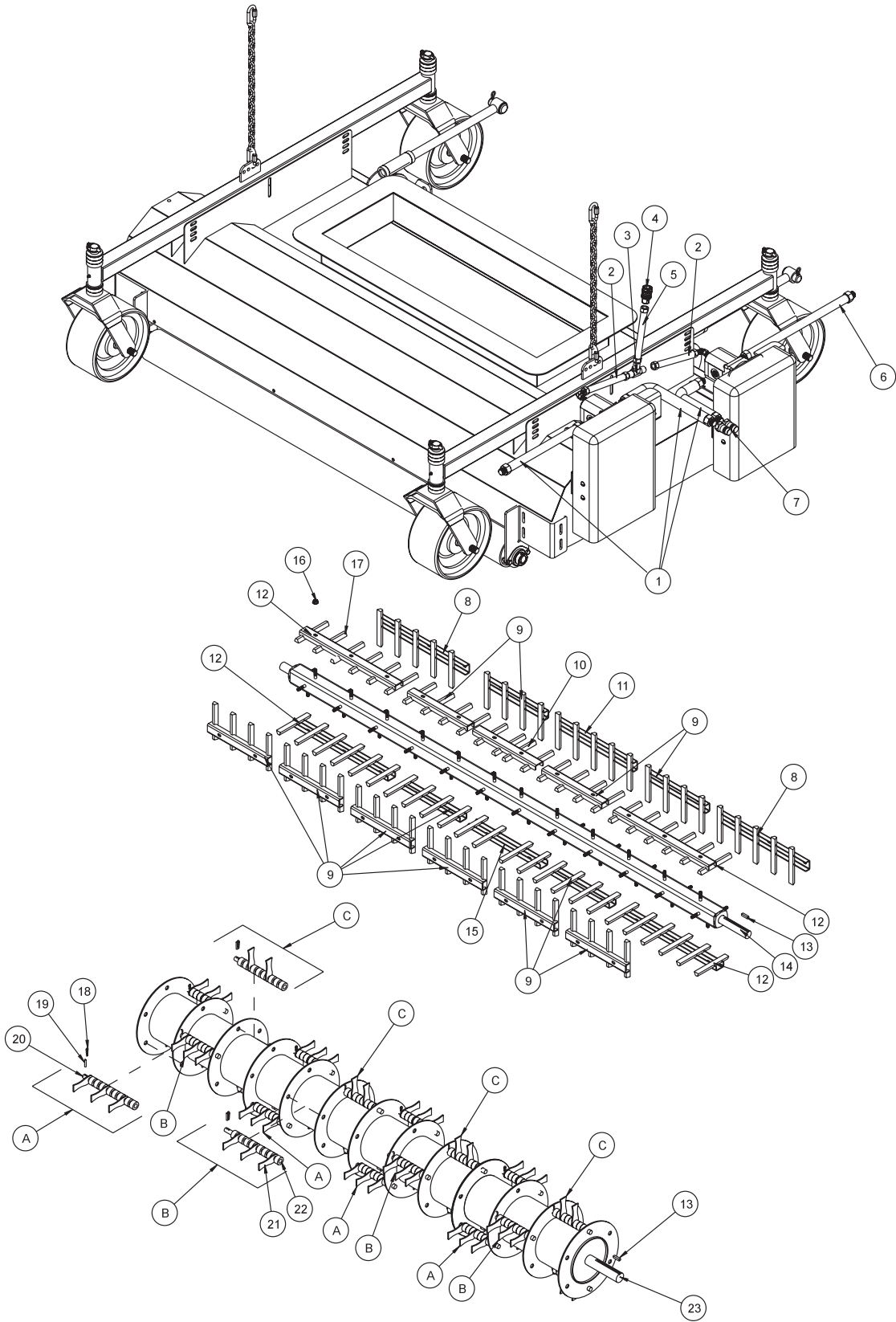

Accessories

## 72-001 COMBINATION SWEEPER - VERTICUT REEL PARTS LIST

REF#	PART#	DESCRIPTION	QUANTITY
1	72-074	Hydraulic Hose 39"	3
2	72-073	Hydraulic Hose 13"	2
3	18-170	Tee	1
4	72-045	<sup>3</sup> / <sub>8</sub> Female Quick Coupler	1
5	72-072	Hydraulic Hose 9"	1
6	72-075	Hydraulic Hose 48"	1
7	72-043	<sup>1</sup> / <sub>2</sub> Male Quick Coupler	2
8	72-091	Finger Clamp 14 <sup>3</sup> / <sub>4</sub> "	2
9	78-297	Finger Clamp 10"	12
10	78-327	Finger Clamp 10 <sup>1</sup> / <sub>2</sub> "	1
11	78-287	Finger Clamp 13"	1
12	72-092	Finger Clamp 16"	4
13	HKSQ-14-100	Square Key <sup>1</sup> / <sub>4</sub> x <sup>1</sup> / <sub>4</sub> x 1	2
14	72-125	Finger Reel	1
15	78-326	Finger Clamp 12"	1
16	HNFL-516-18	Flange Whiz Lock Nut <sup>5</sup> / <sub>16</sub> - 18	48
17	8969-5.250	Sweeper Finger	96
18	HP-316-100	Cotter Pin <sup>3</sup> / <sub>16</sub> x 1	24
19	HRP-316-100	Roll Pin <sup>3</sup> / <sub>16</sub> x 1	24
20	72-104	Blade Rod	24
21	72-039	Flail Blade	66
22	72-051	Spacer	192
23	72-122	Thatch Reel Balanced	1

# 72-002 RUBBER FINGER SWEEPER HEAD DRAWING

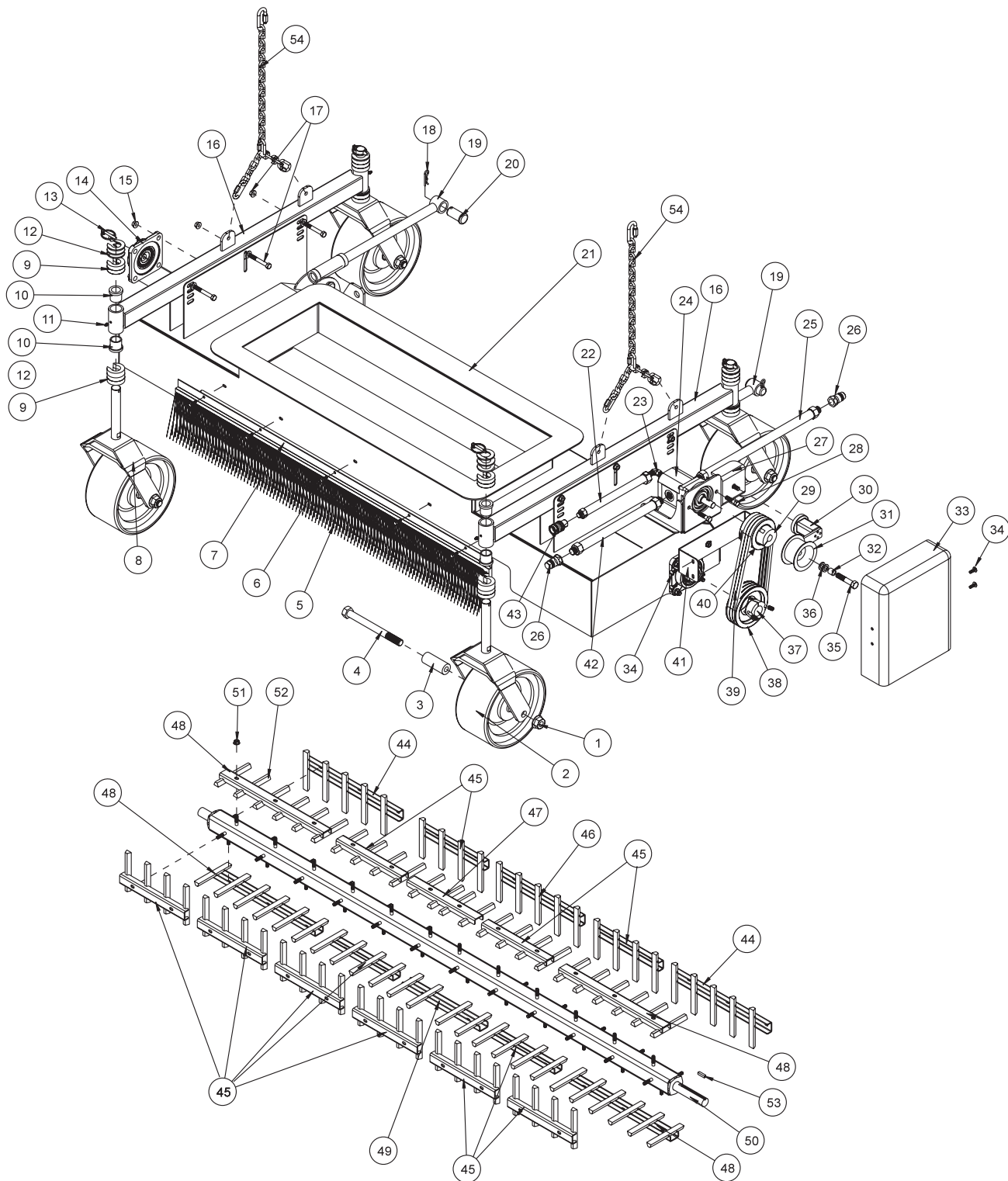

ACCESSORIES



## 72-002 RUBBER FINGER SWEEPER HEAD PARTS LIST

REF#	PART#	DESCRIPTION	QUANTITY
1	HNTL-34-10	Lock Nut $\frac{3}{4}$ - 10	4
2	78-012	Tire and Wheel	4
	78-012-01	Bearing (part of 78-012)	2 per Wheel
3	72-135	Castor Wheel Spacer	8
4	HB-34-10-800	Bolt $\frac{3}{4}$ - 10 x 8	4
5	78-322	Brush	1
6	HB-14-20-075	Bolt $\frac{1}{4}$ - 20 x $\frac{3}{4}$	5
	HNFL-14-20	Flange Whiz Lock Nut $\frac{1}{4}$ - 20	5
7	78-344	Brush Holder	1
8	72-134	Castor Fork	4
9	72-053	Quick Spacer $\frac{1}{2}$ "	20
10	18-223	Flange Bushing (part of 72-139)	8
11	HG-14-28-180	Grease Fitting $\frac{1}{4}$ - 28 x 180° (part of 72-139)	2
12	72-136	Quick Spacer 10GA	12
13	42-539	Lynch Pin $\frac{5}{16}$	4
14	72-023	Flange Bearing	2
	HG-14-28-180	Grease Fitting $\frac{1}{4}$ - 28 x 180° (part of 72-023)	2
15	HNFL-38-16	Flange Whiz Lock Nut $\frac{3}{8}$ - 16	8
	HB-38-16-125	Bolt $\frac{3}{8}$ - 16 x $1\frac{1}{4}$	8
16	72-139	Single Castor Wheel Arm	2
17	HB-38-16-275	Bolt $\frac{3}{8}$ - 16 x $2\frac{3}{4}$	6
	HW-38	Washer $\frac{3}{8}$	6
	HNFL-38-16	Flange Whiz Lock Nut $\frac{3}{8}$ - 16	6
18	HHP-18-100	Bridge Pin $\frac{1}{8}$ x 1 (2 are part of machine)	4
19	72-103	Reel Lift Rod (part of machine)	2
20	HCP-100-200	Clevis Pin 1 x 2 (2 are part of machine)	4
21	72-133	Single Reel Housing	1
	8803-114	Trim Black with Lace 114"	1
22	72-076	Hydraulic Hose 22"	1
23	18-168	Elbow	1
24†	78-219	Hydraulic Motor	1
25	72-075	Hydraulic Hose 48"	1
26	72-043	$\frac{1}{2}$ " Male Quick Coupler	2
27	72-097	Motor Mount	1
	HB-38-16-100	Bolt $\frac{3}{8}$ - 16 x 1	4
	HW-38	Washer $\frac{3}{8}$	4
	HNFL-38-16	Flange Whiz Lock Nut $\frac{3}{8}$ - 16	4
28	HB-38-16-125	Bolt $\frac{3}{8}$ - 16 x $1\frac{1}{4}$	2
	HW-38	Washer $\frac{3}{8}$	2
	HNTL-38-16	Lock Nut $\frac{3}{8}$ - 16	2
29	78-237	Hub	1
	HSSHS-38-16-063	Set Screw $\frac{3}{8}$ - 16 x $\frac{5}{8}$ (part of 78-237)	2

(Continued on next page)

†	78-219-01	Seal kit	1 per
	78-219-02	Driver Coupler	1 per
	HWK-316-063	Woodruff Key $\frac{3}{16}$ x $\frac{5}{8}$	1 per

**No other parts are replaceable for hydraulic motors.**

# 72-002 RUBBER FINGER SWEEPER HEAD DRAWING

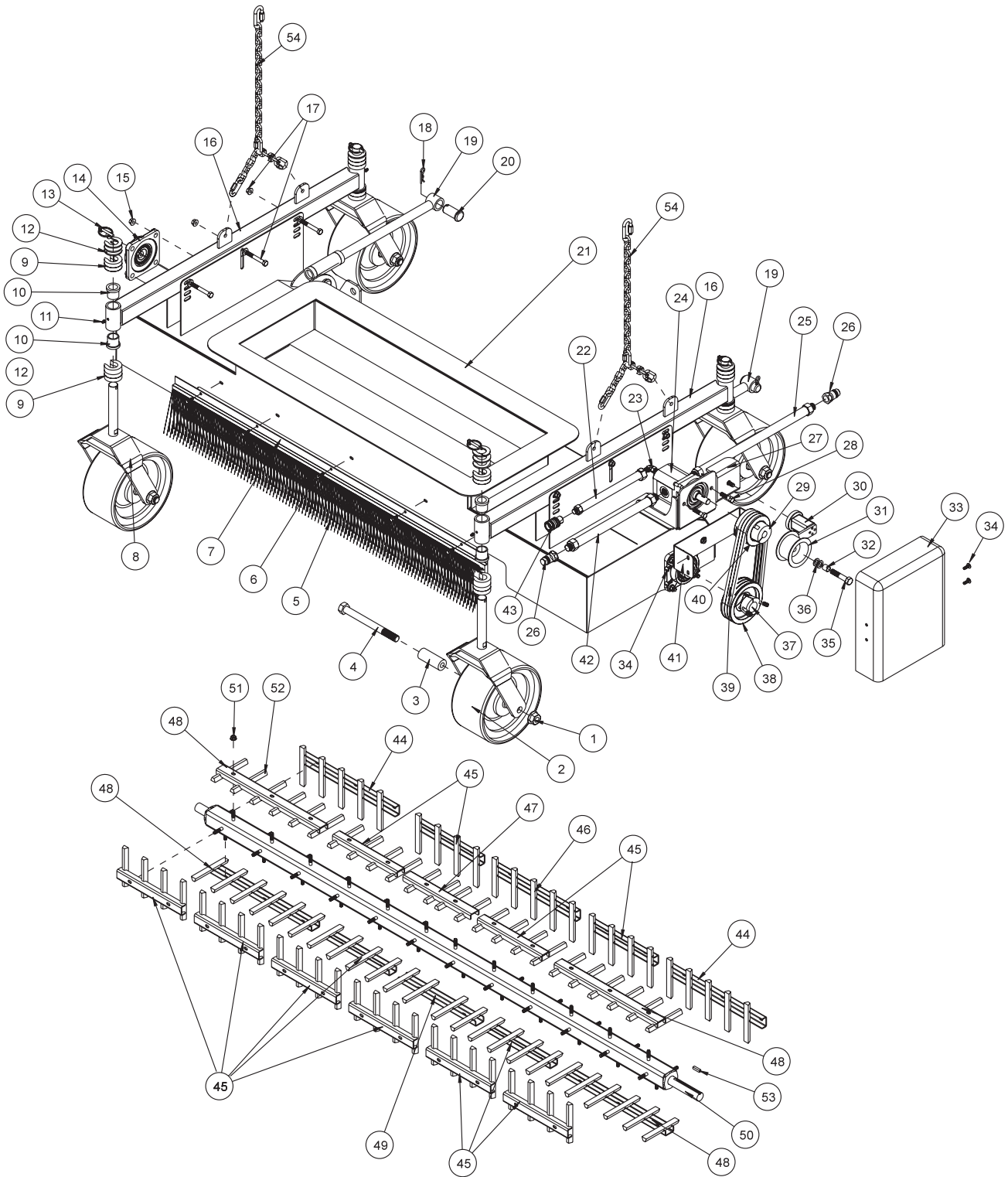

Accessories

## 72-002 RUBBER FINGER SWEEPER HEAD PARTS LIST

REF#	PART#	DESCRIPTION	QUANTITY
30	78-224	Belt Tensioner	1
	HBM-10-1.50-30	Metric Bolt 10 - 1.50 x 30 (part of 78-224)	1
	HWLM-10	Metric Lockwasher 10 (part of 78-224)	1
31	16-013	Idler pulley	1
32	76-275	Spacer (part of 78-224)	1
33	72-056	Belt Guard	1
34	HSTP-14-20-075	Phillip Head Machine Screw $\frac{1}{4}$ - 20 x $\frac{3}{4}$	4
	HNFL-14-20	Flange Whiz Lock Nut $\frac{1}{4}$ - 20	4
35	HB-12-13-250	Bolt $\frac{1}{2}$ - 13 x $2\frac{1}{2}$ (part of 78-224)	1
	HNCL-12-13	Center Lock Nut $\frac{1}{2}$ - 13 (part of 78-224)	1
36	HMB-12-14	Machine Bushing $\frac{1}{2}$ x 14GA	2
37	72-035	Hub $1\frac{1}{4}$	1
	HSSHS-38-16-063	Set Screw $\frac{3}{8}$ - 16 x $\frac{5}{8}$ (part of 72-035)	2
38	78-233	Pulley	1
39	72-038	Belt	3
40	78-232	Pulley	1
41	72-058	Belt Guard Mount	1
	HB-516-18-075	Bolt $\frac{5}{16}$ - 18 x $\frac{3}{4}$	2
	HW-516	Washer $\frac{5}{16}$	2
	HNFL-516-18	Flange Whiz Lock Nut $\frac{5}{16}$ - 18	2
42	72-074	Hydraulic Hose 39"	1
43	72-045	$\frac{3}{8}$ Female Quick Coupler	1
44	72-091	Finger Clamp 14 $\frac{3}{4}$ "	2
45	78-297	Finger Clamp 10"	12
46	78-287	Finger Clamp 13"	1
47	78-327	Finger Clamp 10 $\frac{1}{2}$ "	1
48	72-092	Finger Clamp 16"	4
49	78-326	Finger Clamp 12"	1
50	72-125	Finger Reel	1
51	HNFL-516-18	Flange Whiz Lock Nut $\frac{5}{16}$ - 18	48
52	8969-5.250	Sweeper Finger	96
53	HKSQ-14-100	Square Key $\frac{1}{4}$ x $\frac{1}{4}$ x 1	1
54	72-144	Single Reel Lift Chain	2

### VERTICUT REEL VALVE HANDLE



If the rubber finger sweeper head is installed on your unit and verticut reel handle is activated, the hydraulic system may be damaged due to overheating the oil. Remove the verticut reel valve handle when using the rubber finger sweeper head (72-002).

# 72-004 OVER-THE-ROAD TOWING PACKAGE DRAWING

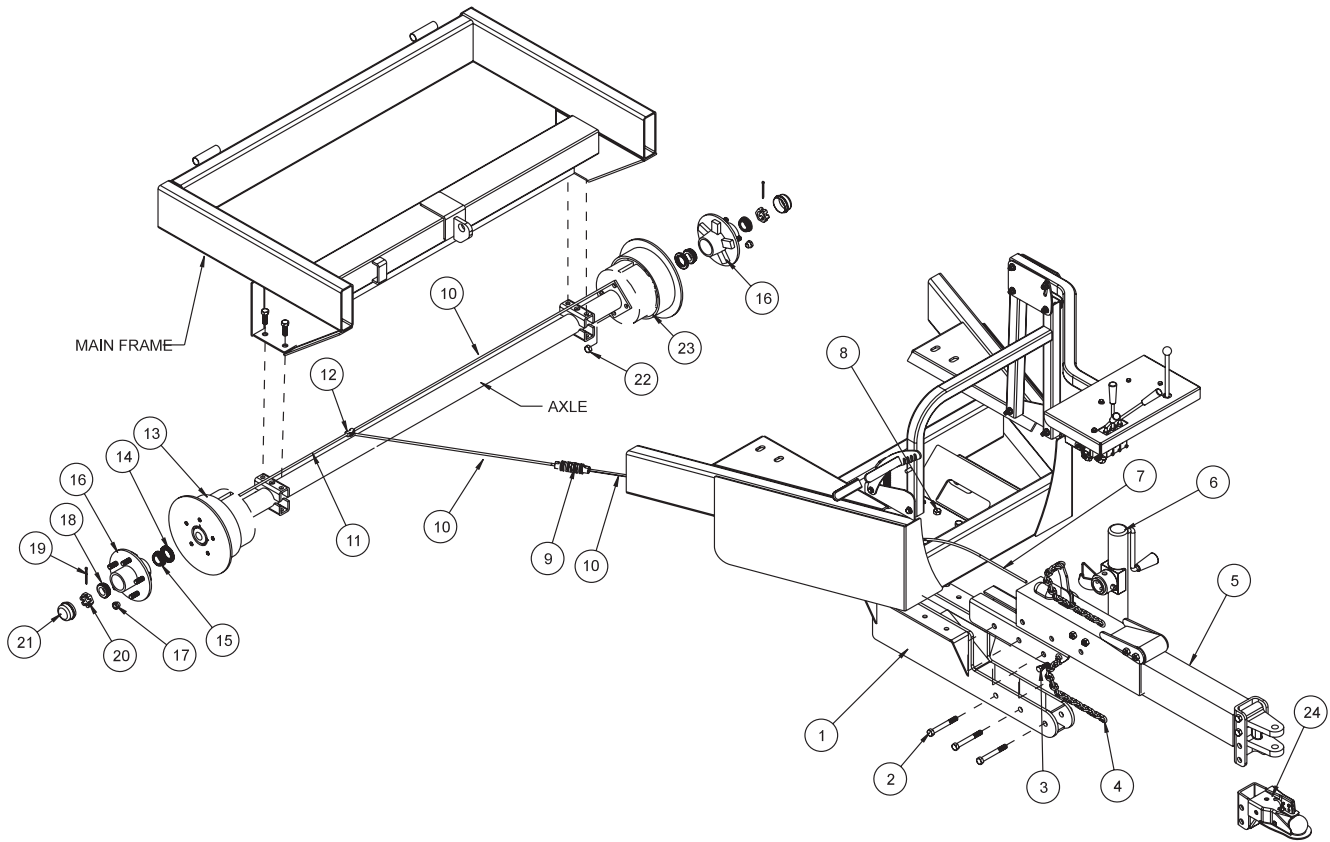

Accessories

## 72-004 OVER-THE-ROAD TOWING PACKAGE PARTS LIST

REF#	PART#	DESCRIPTION	QUANTITY
1	72-172	Surge Brake Mount	1
2	HB-58-11-500	Bolt $\frac{5}{8}$ - 11 x 5	3
	HNTL-58-11	Top Lock Nut $\frac{5}{8}$ -11	3
3	HB-716-14-125	Bolt $\frac{7}{16}$ - 14 x $1\frac{1}{4}$	2
	HNCL-716-14	Center Lock Nut $\frac{7}{16}$ - 14	2
4	72-168	Safety Chain 32"	2
5	72-173	Surge Brake	1
6	78-240	Jack (part of machine)	1
7	72-164	Rubber Brake Hose	1
	21-067	Clip	2
	HSD-8-050	Pan Head Drill Screw #8 x $\frac{1}{2}$	2
8	HB-12-13-125	Bolt $\frac{1}{2}$ - 13 x $1\frac{1}{4}$ (part of machine)	8
	HNTL-12-13	Top Lock Nut $\frac{1}{2}$ -13 (part of machine)	8
9	72-165	Brake Line Coupler	1
10	72-166	60" Brake Line	3
	21-067	Clip	3
	HSD-8-050	Pan Head Drill Screw #8 x $\frac{1}{2}$	3
11	72-167	20" Brake Line	1
12	18-089	Brake Line Tee	1
13	72-161	Right Brake	1
14*	33-073-01	Grease Seal	2
15*	78-118	Inner Bearing	2
16	72-162	Hub Assembly (includes all * items)	2
17*	HNL-12-20	Lug Nut $\frac{1}{2}$ - 20	10
18*	78-119	Outer Bearing	2
19	HP-18-200	Cotter Pin $\frac{1}{8}$ x 2 (part of machine)	2
20	HNAR-100-14	Slotted Jam Nut 1 - 14 (part of machine)	2
21*	33-073-02	Dust Cap	2
22	HN-716-20	Nut $\frac{7}{16}$ - 20	8
	HWL-716	Lockwasher $\frac{7}{16}$	8
23	72-160	Left Brake	1
24	78-245	$2\frac{5}{16}$ Ball Hitch (optional)	1
	78-356	2" Ball Hitch (optional)	1
Not Shown			
A	8898	Brake Fluid	1.5 Pints
B	72-159	Tire and Wheel	2
	72-159-01	Tire	2
	72-159-02	Wheel	2
C	22-075	14" Tie Strap	10
D	72-171	Towing Lights	1

## INSTALLATION INSTRUCTION

- The brakes come completely installed. The tires installed on the unit are towing tires. You also receive the two original turf tires.
- The lights (72-171) are magnetic, so they can be placed on any metal piece on the back of the unit. We suggest you mount them to the bottom of the hopper floor pointing down. One on each side.
- Run the wire harness from the lights up the main frame to the control panel. Hold in place with the 10 tie downs (22-075).
- There are two different types of plug-ins on the end of the light wire harness. Use which ever end suits the tow vehicle the best.
- Test brakes and lights before putting machine in service.



## TOWING SAFETY WARNINGS

1. Connect safety chains properly EVERY TIME YOU TOW. Cross chains under coupler. Attach securely to the hitch or tow vehicle so they can't bounce loose. Leave only enough slack to permit full turning. Too much slack may prevent chains from maintaining control if other connections separate. Don't let chains drag on the road.
2. Make towing light and surge brake connections EVERY TIME YOU TOW, no matter how short the trip. Check operation before getting on the road.
3. Check tire inflation often (min. 35 psi). Follow tow vehicle manufacturers recommendations. Improper tire inflation can cause sweeper to sway.
4. Never allow people in or on sweeper while towing, under any circumstances.
5. The additional weight of a sweeper affects acceleration, braking and handling. Allow extra time for passing, stopping and changing lanes. Severe bumps can damage your towing vehicle, hitch and sweeper. Drive slowly on rough roads. Stop and make a thorough inspection if any part of your towing system strikes the road. Correct any problems before resuming travel.
6. Check for excessive sway and eliminate it. Excessive sway can lead to loss of control. Sway motion should settle out quickly. Sway tends to increase on a downgrade. Starting slowly, increase speed in gradual steps. If sway occurs, adjust load and equipment. Repeat until the trailer is stable at highway speed.
7. Turbulence from another vehicle, a wind gust, or a downgrade can cause sudden sway. So can a shift of the sweepers load or a tire blowout. If the trailer sways it is the driver's responsibility to assess the situation and take appropriate action. Below are suggestions that may apply, depending on conditions:

### SAFE TOWING TIPS

#### DO

- Reduce your speed gradually
- Hold the steering wheel as steady as possible
- Apply the sweeper brakes alone, without using the tow vehicles brakes.

#### DON'T

- Don't hit your brake pedal hard unless absolutely necessary. A "jackknife" can result.
- Don't try to steer out of the sway condition. Sudden or violent steering can make it worse.
- Don't speed up. Sway increases as you go faster.
- Don't continue towing a sweeper that tends to sway. You may lose control during an emergency maneuver or if the conditions listed above occur.



# 72-003 HAND HELD VACUUM HOSE DRAWING

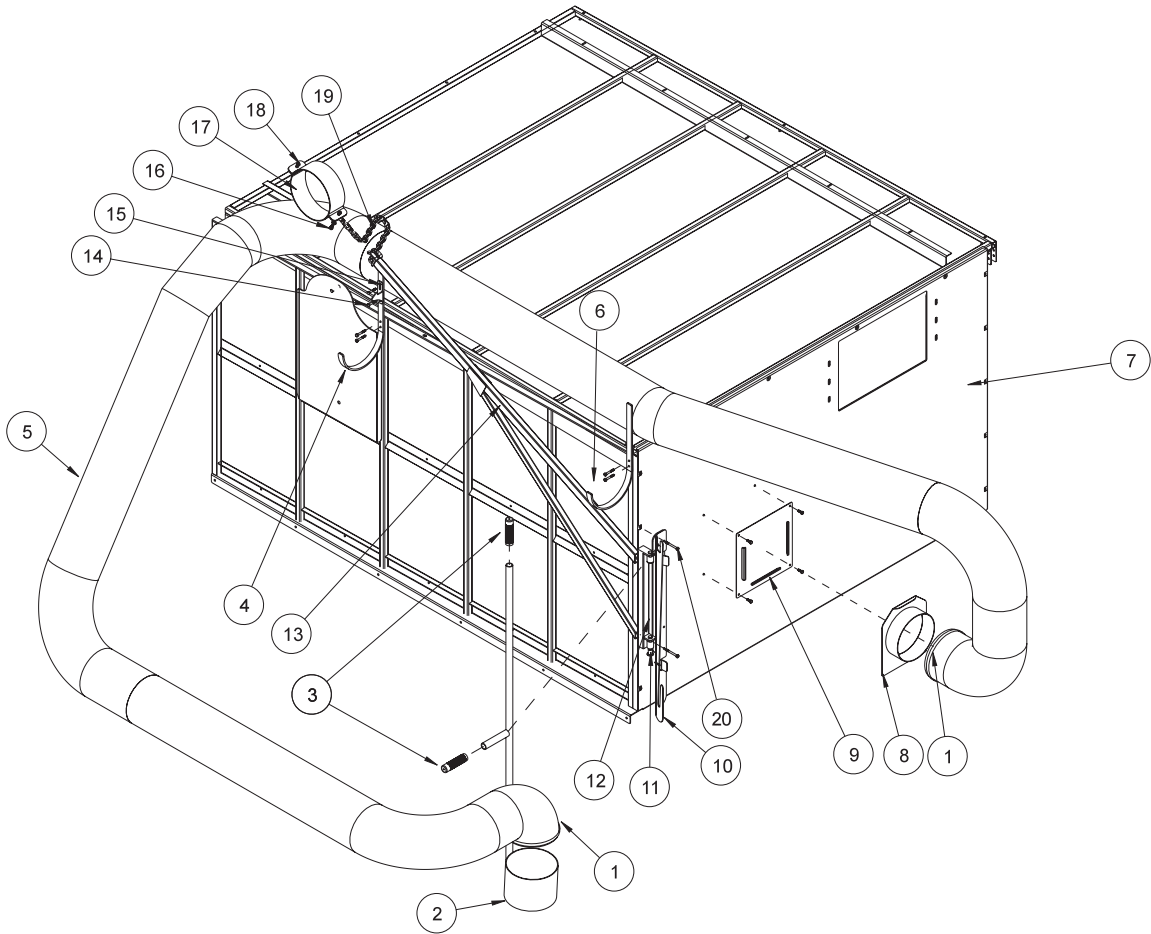

# FRONT VIEW HOLE LOCATION

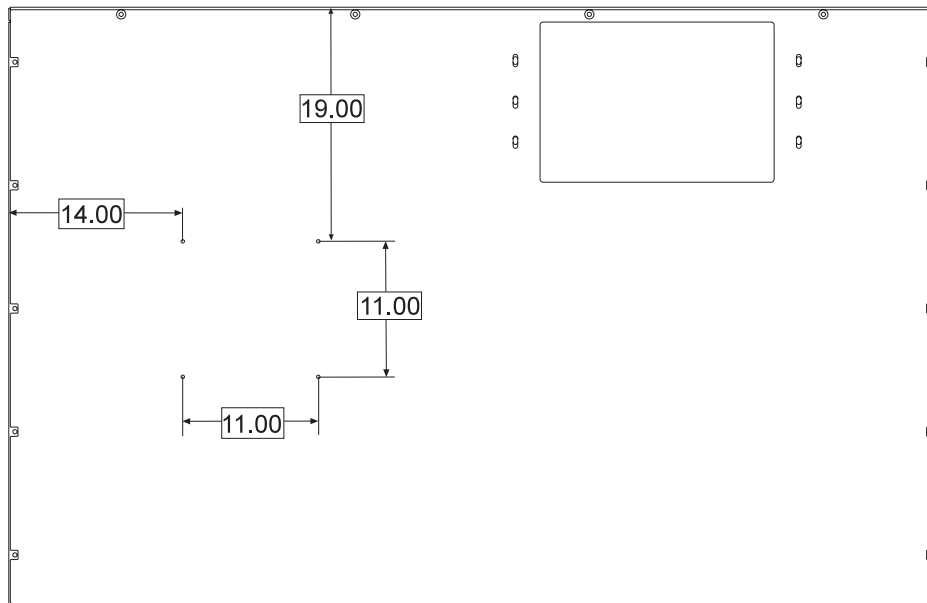

Accessories



## 72-003 HAND HELD VACUUM HOSE PARTS LIST

REF#	PART#	DESCRIPTION	QUANTITY
1	18-340	Hose Clamp	2
2	78-354	Hose Handle	1
3	15-019	Round Grip	2
4	72-142	Hose Hanger	2
	HB-14-20-175	Bolt $\frac{1}{4}$ - 20 x $1\frac{3}{4}$	4
	HNFL-14-20	Flange Whiz Lock Nut $\frac{1}{4}$ - 20	4
5	8970-300	Vacuum Hose	1
6		Hopper Right Side	
7		Hopper Front	
8	78-314	Remote Hose Connection	1
9	72-141	Hose Plate	1
	HB-14-20-075	Bolt $\frac{1}{4}$ - 20 x $\frac{3}{4}$	4
	HNFL-14-20	Flange Whiz Lock Nut $\frac{1}{4}$ - 20	4
10	78-350	Handle Holder	1
	8803-17	Trim, Black	1
11	18-043	Flange Bushing (part of 72-153)	2
12	72-153	Boom Mounting Bracket	1
	HP-18-100	Cotter Pin $\frac{1}{8}$ x 1	2
13	72-155	Vacuum Hose Boom	1
14	HSTP-14-20-075	Machine Screw $\frac{1}{4}$ - 20 x $\frac{3}{4}$	2
	HNFL-14-20	Flange Whiz Lock Nut $\frac{1}{4}$ - 20	2
15	72-152	Latch Bracket	1
16	HB-516-18-075	Bolt $\frac{5}{16}$ - 18 x $\frac{3}{4}$	1
	HW-516	Washer $\frac{5}{16}$	1
	HNFL-516-18	Flange Whiz Lock Nut $\frac{5}{16}$ - 18	1
17	72-154	Hose Clamp	2
18	HB-516-18-075	Bolt $\frac{5}{16}$ - 18 x $\frac{3}{4}$	1
	HNFL-516-18	Flange Whiz Lock Nut $\frac{5}{16}$ - 18	1
19	8820-25	Straight Link Chain 25"	1.
20	HB-14-20-275	Bolt $\frac{1}{4}$ - 20 x $2\frac{3}{4}$	2
	HNFL-14-20	Flange Whiz Lock Nut $\frac{1}{4}$ - 20	2

(Continued on next page)

# INSTALLATION INSTRUCTIONS

You will need two people and the tailgate open with an empty hopper **and the machine not operating**.

1. Drill (4)  $\frac{9}{32}$  holes in front panel (Ref 7) to the left side, see drawing. Start with the top left hole at 19 inches down from the top and 14 inches in from the left.
2. Proceed to drill the three remaining holes in a square pattern at 11 inches apart center to center. Deburr holes and mount the hose plate (Ref 9) and secure with four (4)  $\frac{1}{4}$  -20 x  $\frac{3}{4}$  bolts and flange whiz lock nuts.
3. Next mount the handle holder (Ref 10) facing the front panel, at the left are a vertical row of hex bolts. Remove the second and fourth bolts. Cut 5 inches off of the trim and put it into the top U shaped slot of handle holder. Put the remaining piece into the bottom slot. Install boom mount bracket (Ref 12) between hopper and handle holder. Use  $\frac{1}{4}$  -20 x  $2\frac{3}{4}$  bolts and flange whiz lock nuts (Ref 20). Pull boom mount bracket outward in the slots and tighten bolts.
4. Mount the hose hanger (Ref 4) on the right hand side (Ref 6), in the upper right hand corner. Remove and save the two bolts and nuts that are already in the upper right hand corner. Mount one hose hanger here using the bolts and nut you just removed.
5. To mount the second hose hanger, remove the drill screw in the front upright near the plate for the door arms is welded. Using the screw hole, drill a  $\frac{9}{32}$  hole completely through to the inside and deburr. Mount the hanger with one  $\frac{1}{4}$  - 20 x  $1\frac{3}{4}$  bolt and flange whiz lock nut in the lower hole of the hanger. With the hanger in the vertical position, use the remaining hole as a guide to drill a second mounting hole through to the inside. Deburr and install the remaining bolt and nut.
6. Install latch bracket (Ref 15) using two  $\frac{1}{4}$  - 20 x  $\frac{3}{4}$  machine screws and flange whiz lock nuts (Ref 14).
7. Next install boom (Ref 13) onto boom mount bracket. Hold in place with two  $\frac{1}{8}$  x 1 cotter pins (Ref 11). To adjust, swing boom back alongside the hopper until support comes in contact with the latch bracket. Slide latch bracket upward in the slot holes until it lifts boom  $\frac{1}{8}$ ". Tighten the bolts (Ref 14).
8. Next connect the hose to the hose handle (Ref 2) with hose on the same side as the long handle and secure with one hose clamp (Ref 1). At the other end of the hose connect the remote hose connector and secure with the other hose clamp.
9. Bolt hose clamps (Ref 17) together over the 8" Hose, close to center. Use the  $\frac{5}{16}$  - 18 x  $\frac{3}{4}$  bolt and flange whiz lock nut (Ref 18) on one side. Use the  $\frac{5}{16}$  - 18 x  $\frac{3}{4}$  bolt, washer and flange whiz lock nut (Ref 16) on the other end with the washer between the bolt and the chain. The bolt must go through the end link in the chain first then through the clamp.
10. Put the two round grips (Ref 3) on to the hose handle.
11. For storage place remote hose connector in hose plate (Ref 9) on the front panel. Drape hose over the top and go toward the back of machine. Just past the rear hose hanger bring hose to the side of machine and up into the hose hangers. At the front place the hose handle (Ref 2) into the handle holder (Ref 10).
12. To use the remote vacuum remove the cover plate from either side of the vacuum housing and place the remote hose connector (Ref 8) there. Place the cover plate into the hose plate (Ref 9). Before using the vacuum the lever on the left side of the vacuum housing must be pulled out and turned clockwise 90° and pushed in.
13. You may want to remove the hose handle, hose and remote hose connector if you are not going to use the remote vacuum for an extended amount of time.

## DECAL LIST

25-279	Decal, Safety Warning	Oil tank; Right and left frame fronts.
25-286	Decal, Pinch Point	Right and left tailgate lift arms.
25-355	Decal, Tire Pressure 18 PSI	Rear Wheels
25-356	Decal, Tire Pressure 20 PSI	All Castor Wheels.
25-358	Decal, Smithco 12"	Front of oil tank.
25-359	Decal, Smithco 17"	Tailgate
25-361	Decal, Technical Assistance	Main Frame
25-363	Decal, Max. Depth	Front Hopper
27-093	Decal, Hydraulic Oil	Right side oil tank.
72-047	Decal, Big Vac (Large)	Front blower housing
72-054	Decal, Control Panel	Control Panel
72-061	Decal, Big Vac (Small)	Each side of hopper by tailgate arm
72-087	Decal, Tractor PTO	Two on PTO shaft, Tractor end
72-088	Decal, Danger Guard Missing	PTO Shaft
72-089	Decal, Hose Routing	Left side frame in front
72-182	Decal, Max Load	Front Hopper
75-651	Decal, Hopper Lift Safety	Hopper Lift Safety
76-305	Decal, Rotating Parts	Right and left side of Big Vac cover plates and above door.
76-307	Decal, Tower Warning	One on each side of deck.

# QUICK REFERENCE REPLACEMENT PARTS

## REPLACEMENT FILTER

60-334 Hydraulic Oil Filter Element

## REPLACEMENT BELTS

72-036 Belt 5V x 540 (2 for pump 5 for blower)

72-037 Belt 3V x 400 (thatcher reel) 3

72-038 Belt 3V x 315 (finger reel) 3

## SEAL KITS

33-066 Hydraulic Valve (no seal kit see drawing)\

78-363 Hydraulic Valve 3 Bank

14-205 Seal Kit

10-187 Hydraulic Cylinder

14-273 Seal Kit

72-040 Hydraulic Cylinder

72-040-01 Seal Kit

72-040-02 Pin with Clips (2 per cylinder)

\*72-022 Hydraulic Motor (thatcher reel)

\*78-219 Hydraulic Motor (finger reel)

78-219-01 Seal Kit

78-219-02 Drive Coupler

\*72-021 Hydraulic Pump

72-021-01 Seal Kit

72-077 Hearing Protection

\* NO OTHER PARTS ARE REPLACEABLE FOR HYDRAULIC MOTOR OR PUMP

## HYDRAULIC FLUID

SAE 10W-40 API Service SJ or higher motor oil