



Big Vac
72-000-A
SN: 72308

March 2018

Product Support: Hwy 55 & Poplar Ave; Cameron WI 54822
1-800-891-9435 productsupport@smithco.com

CONTENTS

Introduction

Introduction	1-4
Introduction	1
Safe Practices	2
PTO Safety Warnings	3
Specifications	4
Optional Equipment	4

Service

Service	5-11
Maintenance	5-6
Overloading Debris Hopper and Vacuum Housing Wear	7
Service Chart	8
End User's Service Chart	9
Adjustments	10-11
Storage	11

Diagrams

Diagrams	12-13
Hydraulic Diagram	12-13

Parts

Parts	14-31
Big Vac Main	14-15
Control Panel	16-17
Oil Tank	18-19
Blower Housing	20-21
Vacuum Housing Belts and Tensioners	22-23
Hopper	24-25
72-151 Hydraulic Valve	26-27
78-416 3 Bank Hydraulic Valve	28-29
72-048 Axle	30-31
72-202 PTO Shaft	30-31

Accessories

Accessories	32-48
72-001 Combination Sweeper - Verticut Head	32-37
72-002 Rubber Finger Sweeper Head	38-41
72-005 Brush Reel Sweeper Head with 72-006 Brush Only	42-45
72-003 Hand Held Vacuum Hose	46-48

Reference

Reference	49-50
Decal List	49
Quick Reference Replacement Parts	50
Warranty	Inside Back Cover

Thank you for purchasing a **Smithco** product.

Read this manual and all other manuals pertaining to the Big Vac carefully as they contain safety, operating, assembly and maintenance instructions. Failure to do so could result in personal injury or equipment damage. Keep manuals in a safe place after operator and maintenance personnel have read them. Right and left sides are from the operator's seat, facing forward.

 **WARNING:**

This vehicle can expose you to chemicals known to the State of California to cause cancer, birth defects, and other reproductive harm.
For more information visit www.P65Warning.ca.gov

WARNING

Failure to follow cautious operating practices can result in serious injury to the operator or other persons. The owner must understand these instructions, and must allow only trained persons who understand these instructions to operate this vehicle.

All **Smithco** machines have a Serial Number and Model Number. Both numbers are needed when ordering parts. The serial number plate on the Big Vac is located on the front cross member on the frame. Refer to engine manual for placement of engine serial number.

For product and accessory information, help finding a dealer, or to register your product please contact us at <http://www.Smithco.com>.

Information needed when ordering replacement parts:

1. Model Number of machine
2. Serial Number of machine
3. Name and Part Number of part
4. Quantity of parts

For easy access record your Serial and Model numbers here.

SMITHCO WAYNE, PENNSYLVANIA 19087 USA 610-688-4009 Fax 610-688-6069			
SERIAL NO. <input type="text"/>	kW/hp <input type="text"/>	DATE OF MFG. <input type="text"/>	
MODEL NO. <input type="text"/>	lb/kg Empty <input type="text"/>	lb/kg Full <input type="text"/>	

SMITHCO CUSTOMER SERVICE 1-800-891-9435

SAFE PRACTICES

1. It is your responsibility to read this manual and all publications associated with this machine (engine, accessories and attachments).
2. Never allow anyone to operate or service the machine or its attachments without proper training and instructions. Never allow minors to operate any equipment.
3. Learn the proper use of the machine, the location and purpose of all the controls and gauges before you operate the equipment. Working with unfamiliar equipment can lead to accidents.
4. Wear all the necessary Personal Protective Equipment (PPE) to protect our head, eyes, ears, hands and feet. **Ear and eye protection are required.** Operate the machine only in daylight or in good artificial light.
5. Inspect the area where the equipment will be used. Beware of overhead obstructions and underground obstacles. Stay alert for hidden hazards.
6. Never operate equipment that is not in perfect working order or without decals, guards, shields, or other protective devices in place.
7. Never disconnect or bypass any switch.
8. Carbon monoxide in the exhaust fumes can be fatal when inhaled, never operate a machine without proper ventilation.
9. Never use your hands to search for oil leaks. Hydraulic fluid under pressure can penetrate the skin and cause serious injury.
10. This machine demands your attention. To prevent loss of control or tipping of the vehicle:
 - A. Use extra caution in backing up the vehicle. Ensure area is clear.
 - B. Do not stop or start suddenly on any slope.
 - C. Reduce speed on slopes and in sharp turns. Use caution when changing directions on slopes.
 - D. Stay alert for holes in the terrain and other hidden hazards.
 - E. Operate equipment up and down slopes, never across the face.
11. Before leaving operator's position for any reason:
 - A. Disengage all drives.
 - B. Lower all attachments to the ground.
 - C. Shut engine off and remove the ignition key.
12. Keep hands, feet and clothing away from moving parts. Wait for all movement to stop before you clean, adjust or service the machine.
13. The rubber fingers, sweeper and vacuum pick up and propel debris and small objects in machines path during operation. Keep the area of operation clear of all bystanders.
14. Never carry passengers.
15. Use parts and materials supplied **Smithco** by only. Do not modify any function or part.
16. Avoid sharp turns. Watch the tires of the tractor while turning to make sure they do not contact the tongue of the Big Vac.
17. Shut down power source before attempting to unclog any part of the machine.
18. If reel deck and/or blower began to vibrate abnormally, immediately shut off power and determine the cause.
19. Always drive at a safe towing speed relative to conditions and ensure that your speed is low enough for an emergency stop to be safe and secure. Smithco recommends a maximum speed of 8mph (12 kph).

These machines are intended for professional maintenance on golf courses, sports turf, and any other area maintained turf and related trails, paths and lots. No guaranty as to the suitability for any task is expressed or implied.

PTO SAFETY WARNINGS

1. Always disengage the PTO, shut off engine and remove the keys before leaving the tractor seat.
2. Keep the tractor's master shield in place at all times.
3. Missing or damaged shielding is the main reason for drive-line entanglement. **Keep All Guards** on and in good condition. Check guards frequently.
4. **Never** step across a rotating power shaft. Always walk around the revolving shaft even if guards are in place.
5. Dress for safety. Do not wear loose fitting clothes or jewelry and keep long hair covered or pulled back.
6. The tractor draw-bar should be adjusted to the length specified in the driven machine's manual. This will help prevent drive-line stress and separation on uneven terrain and in tight turns.
7. A PTO shaft may break or separate during operation if improperly installed or adjusted. Be sure PTO shaft is installed properly. **See image below.**
8. Never perform maintenance or adjustments until both the drive-line and the machinery have stopped moving.
9. Warn anyone who might come near an operating PTO about the entanglement hazard.
10. Regularly test drive-line guards by spinning or rotating them to ensure they have not become stuck to the shaft.
11. Always use the drive-line recommended for your machine. Never switch drive-lines among different machines.
12. Reduce PTO shaft abuse by observing the following:
 - a. Avoid tight turns that pinch rotating shafts between the tractor and machine.
 - b. Keep excessive telescoping to a minimum.
 - c. Engage power to the shaft gradually.
 - d. Avoid over tightening of slip clutches on PTO driven machines.



PTO connection with larger guard housing goes to the tractor.

SPECIFICATIONS FOR BIG VAC

WEIGHTS AND DIMENSIONS

Length	180" (458 cm)
Width	84" (214 cm)
Height	87" (221 cm)
Weight	3500 lb (1588 kg)

SOUND LEVEL

At Ear Level	92 dB (Use ear protection while operating)
--------------	--

PTO SHAFT

Maximum RPM	540
-------------	-----

TIRES & WHEELS

Two 26.5 - 1400 x 12 (18 psi (1.3 bar)) Fairway Type Turf Tires
 Castor: 13 x 5 x 6 (20 psi (1.4 bar))

FLUID CAPACITY

Hydraulic Fluid	17 gallon (64 liters)
Grade of Hydraulic Fluid	SAE 10W-40 API Service SJ or higher Motor Oil

OPTIONAL EQUIPMENT

- 72-001 Combination Verticut and Sweeper Head
- 72-002 Rubber Finger Sweeper Head
- 72-003 25ft Hand Held Vacuum
- 72-004 Over-the-Road Tow Package
- 72-005 Nylon Brush Sweeper Head
- 72-245 2⁵/₁₆ Ball Hitch

⚠ CAUTION

Before servicing or making adjustments to machine, stop engine on tow vehicle and remove key from ignition.

🔑 IMPORTANT

Use all procedures and parts prescribed by the manufacturer's. Read the engine manual before operation.

LUBRICATION

Use No. 2 General Purpose Lithium Base Grease and lubricate **DAILY**. The Big Vac has 19 to 25 grease fittings, depending on what sweeper head you are using. All bearings are sealed bearings. When inserting grease, be careful not to ruin the seal, if this happens, replace the bearing at once. Be sure to wipe grease fitting clean before injecting grease. Give only one or two pumps of grease at each lubrication.

REF# LOCATION

- 1 One on all four castor wheels.
- 2 Four on the front of the blower that go to pillow blocks on blower and PTO shafts.
- 3 One on each mounted bearing for reel shaft. Two for finger reel. Four for combination head.
- 4 One on each end of the PTO shaft.
- 5 One on all four castor wheel mount brackets.
- 6 One on the jack stand.
- 7 One on each end of roller - Combination head only.

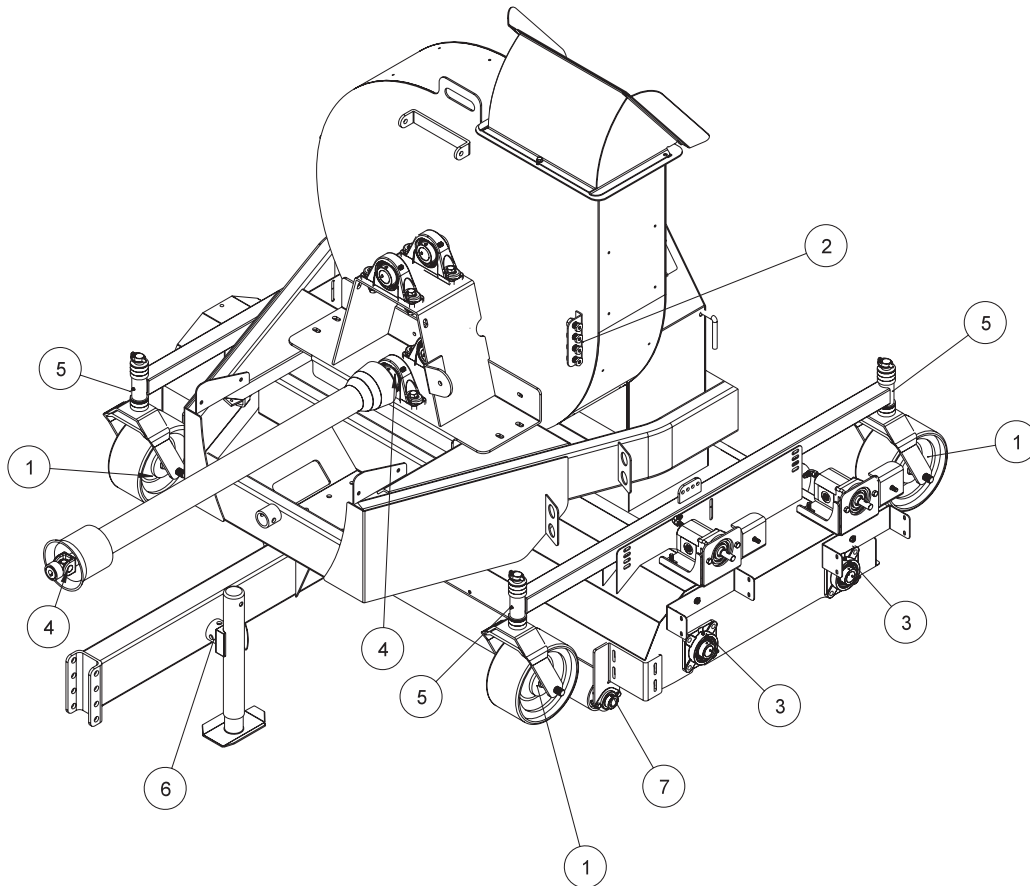

MAINTENANCE (CONTINUED)

TIRE PRESSURE

Caution must be used when inflating a low tire to recommended pressure. Over inflating can cause tires to explode. Tires on the machine should be 18 psi (1.3 bar), castor wheels should be 20 psi (1.4 bar). Improper inflation will reduce tire life considerably.

WHEEL MOUNTING PROCEDURE

1. Turn machine off and remove key.
2. Be sure unit is on a level surface. Unhitch from tow vehicle if possible.
3. Block the opposite wheel then the one you are working on.
4. Loosen nuts slightly on wheel to be removed.
5. Jack up machine being careful not to damage underside of machine.
6. Remove nuts, remove wheel.
7. Place new wheel on hub lining up Hex Bolt holes.
8. Torque nuts to 64-74 ft/lb (87-100 Nm) using a cross pattern. Torque again after first 10 hours and every 200 hours thereafter.
9. Lower machine to ground and remove blocks and jack.

HYDRAULIC OIL

1. Use SAE 10W-40 API Service SJ or higher motor oil.
2. For proper warranty, change oil every 500 hours or annually, which ever is first and change the filter after the first 20 hours, then at 100 hours, then every 250 hours thereafter.
3. Inspect hydraulic lines for damage or leaks. Never use hands to inspect leaks.
4. Check hydraulic fluid level in tank. Look at the sight gauge on the front left side of the tank. The oil level should be at 90°C (194°F). If level is low, add SAE 10W-40 API Service SJ or higher motor oil.
5. After changing oil and/or filter, operate the machine for a few minutes. Check oil level and for leaks.
6. Always use caution when filling hydraulic oil tank or checking level to keep system free of contaminants. Check and service more frequently when operating in extremely cold, hot or dusty conditions.
7. If natural color of fluid is now black or smells burnt, it is possible that an overheating problem exists.
8. If fluid becomes milky, water contamination may be a problem.
9. If either of the above conditions happen, change oil and filter immediately after fluid is cool and find cause. Take fluid level readings when system is cold.
10. In extreme temperatures you can use straight weight oil. We recommend SAE 30W API Service SJ or higher when hot (above 90°F (33°C)) and SAE 10W API Service SJ or higher when cold (below 32°F (0°C)) ambient temperature. Use either motor oil or hydraulic oil, but do not mix.
11. Oil being added to the system must be the same as what is already in the tank. Mark tank fill area as to which type you put in.

VERTICUT REEL VALVE HANDLE

WARNING

If the rubber finger sweeper head is installed on your unit and verticut reel handle is activated, the hydraulic system may be damaged due to overheating the oil. Remove the verticut reel valve handle when using the rubber finger sweeper head (72-002).

MAINTENANCE (CONTINUED)

HOPPER LIFT SAFETY

The Hopper Lift Safety is used to support the ram on the hopper bottom in the extended position so you may service or repair the machine under the hopper. When not in use the Hopper Lift Safety can be stored on the hopper bed frame.

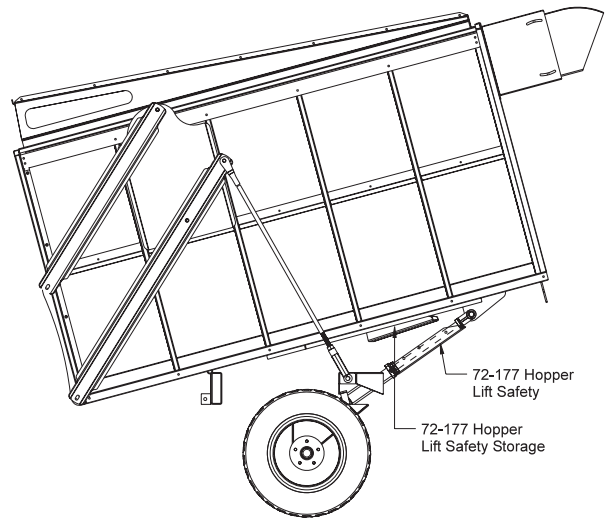

OVERLOADING DEBRIS HOPPER AND VACUUM HOUSING WEAR

SMITHCO SWEEPER-VACS ARE DESIGNED TO CARRY THE FOLLOWING MAXIMUM LOADS:

Model 72-000 Big Vac

1500 lbs. (608 kg)

PLEASE NOTE THE FOLLOWING:

1. Loads heavier than that will damage the unit.
2. Such damage is not covered by warranty.
3. Overloading is particularly easy when collecting aerifier cores.
4. The hoppers on the Big Vac and V62 are large in order to hold 7 and 4 cubic yards respectively, of thatch, grass clippings, leaves and trash.
5. They will not hold 7 or 4 cubic yards of aerifier cores.
6. The maximum depth (in the debris hopper) of aerifier cores is:

Model 72-000 Big Vac

12 in. (30 cm)

VACUUM HOUSING WEAR

The Big Vac & V62 are fitted with a wear resistant liner in the vacuum housing. This will provide additional housing life. Be sure the following points are explained to the user:

1. The vacuum housing and impeller must be cleaned each time the unit is used so the housing liner is inspected daily. Only Smithco Sweeper-Vacs provide a clean out/inspection port for easy inspection and cleaning.
2. When bare steel is visible at any point in the housing lining, the lining must be replaced. It is expected the liner will wear and be replaced. It is a vast improvement over competitive units with no liners.
3. Replacement of the liner or the vacuum housing due to wear is normal and is not covered by warranty.
4. Collection of aerifier cores causes extreme wear on the liner (and if unchecked, on the housing).
5. Caution users that, while Smithco Sweeper-Vacs do an excellent job collecting cores, the lining (and the housing) will wear quickly in such use.

RUBBERIZED BOOT

The rubberized boot between main unit and sweeper head is subject to wear and damage from debris. Unless defective, replacement of this boot is not covered by warranty.



SERVICE CHART

⚠ CAUTION

Before servicing or making adjustments to the machine, stop engine, set park break, block wheels and remove key from ignition.

⚠ IMPORTANT

Follow all procedures and **ONLY** use parts prescribed by the manufacturer. Read the engine manual before maintenance.

The suggested maintenance checklist is not offered as a replacement for the manufacturer's engine manual but as a supplement. You must adhere to the guidelines established by the manufacturer for warranty coverage. In adverse conditions such as dirt, mud or extreme temperatures, maintenance should be more frequent.

Maintenance Service Interval	Maintenance Procedure
After the first 5 operating hours	Torque the wheel lug nuts. (64-74 ft/lb (87-100 Nm))
	Grease PTO Shaft
Before each use daily	Check guards on PTO Shaft
	Open trap door and inspect Blower Housing
	Check the tire pressure.
	Inspect and clean the machine.
Every 100 Hours	Lubricate machine.
	Torque the wheel lug nuts. (64-74 ft/lb (87-100 Nm))
	Check belt tension.
Every 400 hours or yearly	Check hydraulic Lines.
	Clean Blower Housing. ¹
	Check Boot for cracks or rips.
	Lubricate machine.
1 In dusty conditions or when airborne debris is present, clean more often.	

END USER'S SERVICE CHART

Maintenance Check Item	For the week of:						
	Mon	Tues.	Wed.	Thurs.	Fri.	Sat.	Sun.
Check the PTO Shaft guards							
Check the engine oil level.							
Check the condition of the Blower Housing							
Clean the debris from pulleys and belts							
Check the tire pressure (18 psi)							
Check the Instrumentation							
Inspect hydraulic system							
Lubricate Machine and Booms							
Ensure all warning decals are intact.							
Areas of Concern							
Inspection Performed by:							
Item	Date		Information				

Service

ADJUSTMENT OF BELT TENSIONER

There are four maximum belt tensioners on the Big Vac. Two control the tension on the belts on the blower housing, one each on the finger reel and the thatcher reel. The proper tension of the idler should be 12 to 15 as per the gauge (A) on the side of the tightener. Over tightening the belt will shorten the life of the belt and the machine may not perform to the best of its ability. To adjust belt tensioner, loosen Hex Bolt holding tensioner. Bring idler pulley tight to belts and turn tensioner into belts to 15°. Tighten holder Hex Bolt.

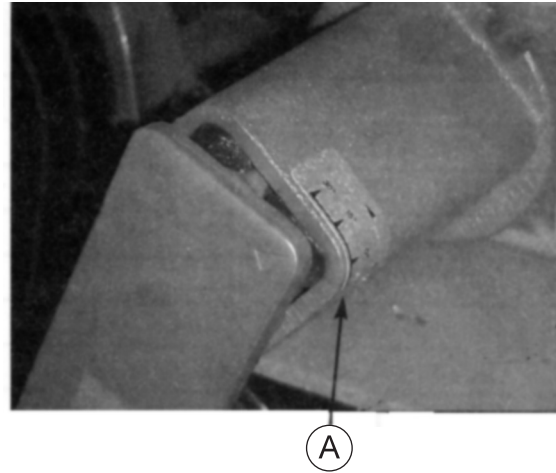

CONTROL PANEL ADJUSTMENT ARM

On the right hand side of machine is the adjustment lock arm, by lifting up you can adjust the control panel by moving it forward or rearward. Make certain that the lock arm is locked back in place after adjustment. For up and down adjustment loosen the four adjustment Hex Bolts place the control panel to where you want it and tighten the four Hex Bolts.

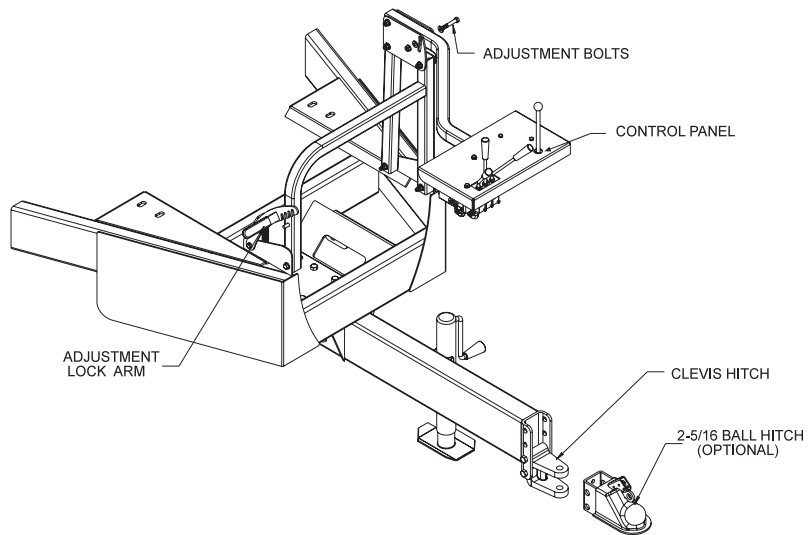

HITCH OPTIONS

You may use the clevis hitch that is shipped with your machine or a 2⁵/₁₆ ball hitch that is an optional accessory. Both mount in the same location with three different Hex Bolt hole options.

VERTICUT REEL VALVE HANDLE

WARNING

If the rubber finger sweeper head is installed on your unit and verticut reel handle is activated, the hydraulic system may be damaged due to overheating the oil. Remove the verticut reel valve handle when using the rubber finger sweeper head (72-002).

ADJUSTMENTS

CASTOR WHEELS

The castor wheel height spacers are quick spacers meaning they have a slot cut out of them. The castor fork shaft has two flats on it near the bottom. To remove the quick spacers (A) lift up on the castor wheel (C) and remove lynch pin (B). Let the castor wheel come down some, take the quick spacer up and turn it until you feel the flats on the shaft then pull out. This removes the spacers below the castor arm (D), reverse the procedure to add spacers. The thin quick spacers must not be placed in line with the flats on the shaft or they will fall out. Check the tire pressure on castor wheels, they should be 20 psi (1.4 bar).

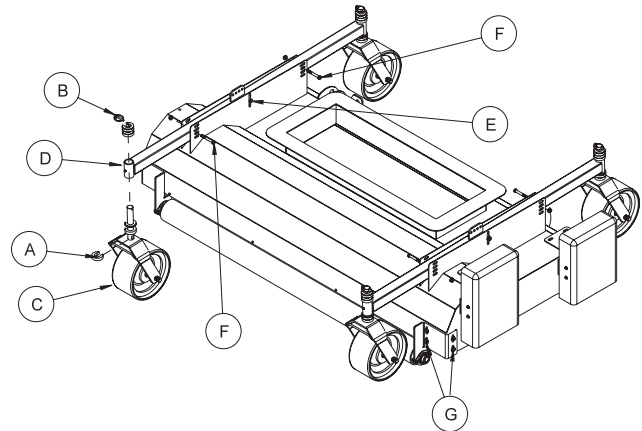

DOUBLE REEL HOUSING

Normal setting is three slots down in front and two slots down in rear (both sides). You may want to change the normal setting to compensate for wear of the flail blades or sweeper fingers or to sweep without cutting. To do this loosen Hex Bolt (E) and remove Hex Bolts (F) both sides. Then tip the reel housing to the desired position. Replace Hex Bolts and tighten all Hex Bolts. This can also be done in conjunction with the castor wheel height adjustment spacers.

ANTI SCALP ROLLER (DOUBLE REEL)

Normal setting for the anti scalp roller is with the machine on a level hard surface. Normal setting is with the bottom of the roller to be ¼ inch above the flail blades, with flail blades in their lowest position. To adjust loosen the four Hex Bolts (G) both sides and slide the roller up or down. Tighten all Hex Bolts.

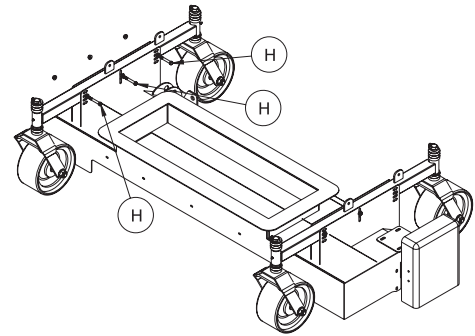

SINGLE REEL HOUSING

Normal setting is two slots down (H) both front and rear (both sides).

STORAGE

1. Before storing clean machine thoroughly.
2. Check Hex Bolts and nuts, tighten as necessary.
3. Make all repairs that are needed and remove any debris.
4. Store in a clean and dry area.

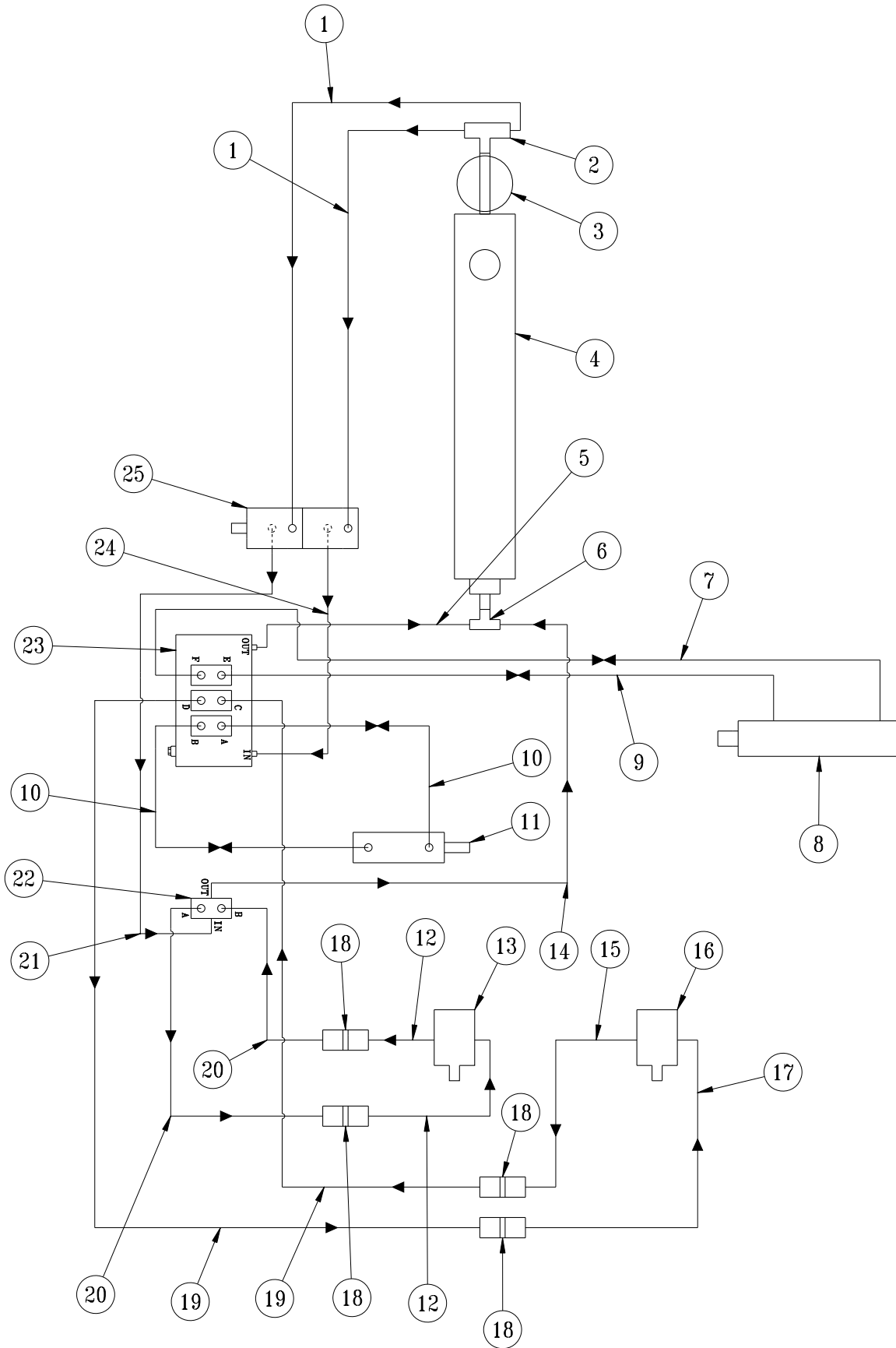

HYDRAULIC PARTS LIST

REF#	PART#	DESCRIPTION	QUANTITY
1	72-079	Suction Hose	2
2	18-276	Tee Fitting, 1 1/4	1
3	72-146	Filter	1
	60-334	Filter Element (replacement only)	1
4	72-041	Hydraulic Tank	1
5	73-029	Hydraulic Hose	1
6	18-447	Run Tee	1
7	72-065	Hydraulic Hose	1
8	72-040	Cylinder	1
	72-040-01	Seal Kit	1
	72-040-02	Pin with Clips (part of 72-040)	2
9	72-064	Hydraulic Hose	1
10	72-071	Hydraulic Hose	2
11	10-187	Hydraulic Cylinder	1
	14-273	Seal Kit	1
12	72-074	Hydraulic Hose	2
13*	72-187	Hydraulic Motor (Thatch Reel)	1
	72-186-01	Seal Kit	1
14	72-066	Hydraulic Hose	1
15	72-074	Hydraulic Hose	1
16*	72-186	Hydraulic Motor (Reel)	1
	72-186-01	Seal Kit	1
17	72-075	Hydraulic Hose	1
18	72-043	Quick Coupler 1/2 Male End	4
	72-046	Quick Coupler 1/2 Female End	4
	HRR-150	Retaining Ring 1 1/2" External	8
19	72-068	Hydraulic Hose	2
20	72-067	Hydraulic Hose	2
21	72-069	Hydraulic Hose	1
22	72-151	Hydraulic Valve	1
23	78-416	Hydraulic 3 Bank Valve	1
24	72-062	Hydraulic Hose	1
25*	72-185	Hydraulic Double Pump	1
	78-413-01	Front Pump Seal Kit	1
	72-185-01	Rear Pump Seal Kit	1

* No other parts are replaceable for hydraulic motor or pump.

HYDRAULIC PRESSURES

	FRONT	REAR
Pump Displacement	.90 in ³ /rev	.40 in ³ /rev
Pump Input Speed (up to)	4000 rpm	4000 rpm
Max. Operating Pressure	3600 psi	3600 psi
Max. Inlet Vacuum	10 in. Hg	10 in. Hg
Max. Case Pressure	80 psi	80 psi

BIG VAC MAIN DRAWING

PARTS

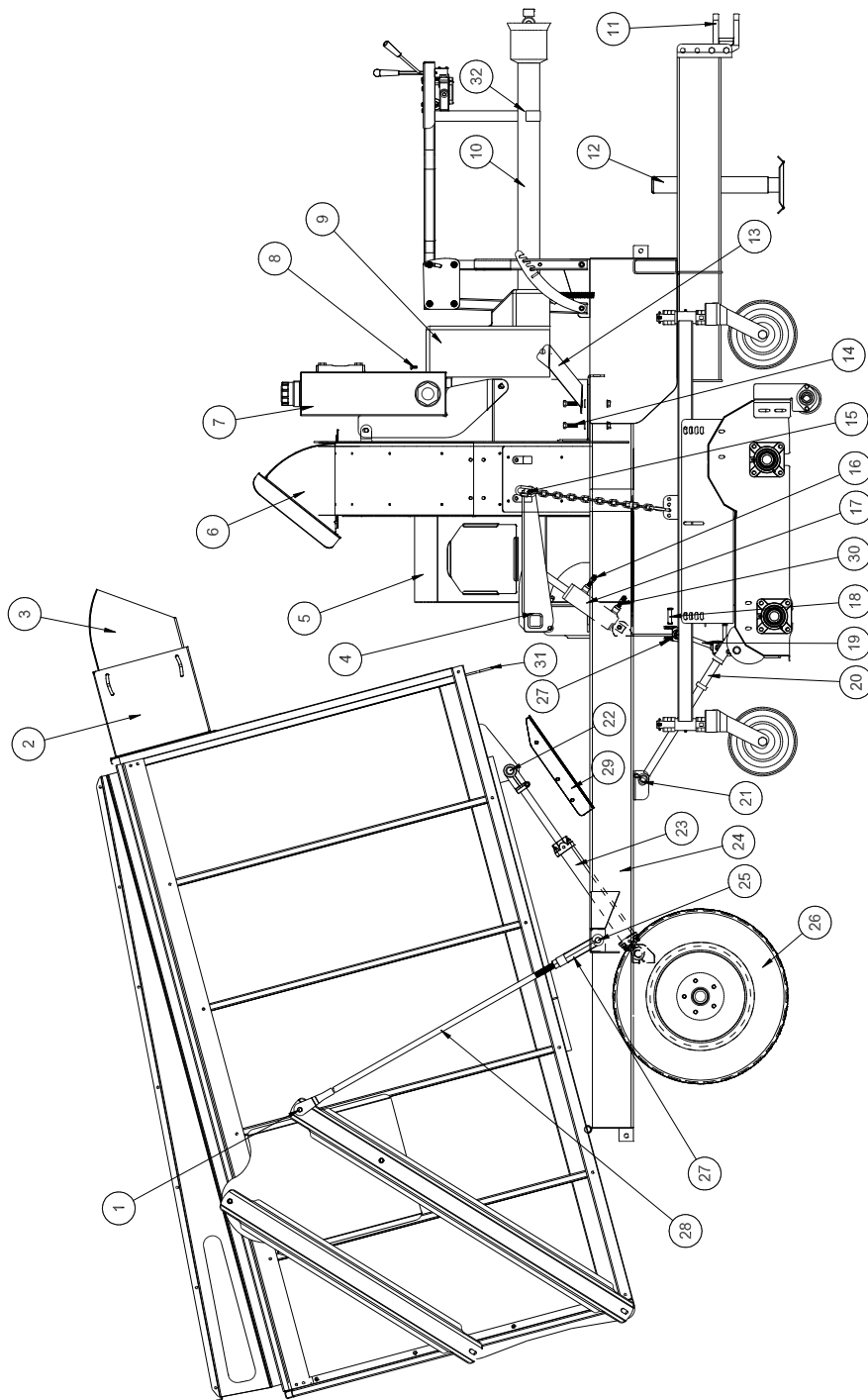

BIG VAC MAIN PARTS LIST

REF#	PART#	DESCRIPTION	QUANTITY
1	HCP-12-175	Clevis Pin, 1/2 x 1 3/4	2
	HP-18-100	Cotter Pin, 1/8 x 1	2
2	72-110	Hopper Chute	1
3	72-111	Middle Chute	1
4	73-061	Reel Lift Cross Bar	1
	HB-12-13-125	Hex Bolt, 1/2 - 13 x 1 1/4	2
	HNTL-12-13	Nylon Lock Nut 1/2 - 13	2
5	72-081	Vacuum Housing	1
6	72-109	Blower Chute	1
7	72-041	Hydraulic Oil Tank	1
8	HSTP-516-18-075	Phillips Truss Head Machine Screw 5/16 - 18 x 3/4	6
9	72-143	Front PTO Cover	1
	78-274	Cage Nuts	6
10	72-202	PTO Shaft	1
11	78-244	3/4" Clevis	1
12	78-240	Jack	1
13	72-149	Right PTO Cover Bracket	1
	72-150	Left PTO Cover Bracket	1
14	HB-12-13-150	Hex Bolt, 1/2 -13 x 1 1/2	4
	HW-12	Flat Washer, 1/2	4
	HNFL-12-13	Flange Whiz-loc Nut, 1/2 - 13	4
15	HCP-12-200	Clevis Pin, 1/2 x 2	2
	HP-18-100	Cotter Pin, 1/8 x 1	2
16	18-169	Adapter	2
17	10-187	Hydraulic Cylinder	1
	14-273	Seal Kit	1
	HCP-12-200	Clevis Pin, 1/2 x 2	2
	HP-18-100	Cotter Pin, 1/8 x 1	2
18	HCP-34-200	Clevis Pin, 3/4 x 2	2
	HP-18-100	Cotter Pin, 1/8 x 1	2
19	72-148	Sway Bar	1
20	72-103	Reel Lift Rod	2
21	HCP-100-200	Clevis Pin, 1 x 2	4
	HHP-.177	Bridge Pin, .177 x 3.75	4
22	72-040-02	Pin with Clips (part of 72-040)	2
23	72-040	Hydraulic Cylinder	1
	72-040-01	Seal Kit	1
	23-184	Male Connector	2
24	72-080	Main Frame	1
25	HMB-34-10	Machine Bushing, 3/4 x 10GA	6
	HP-18-100	Cotter Pin 1/8 x 1	2
26	72-042	Tire and Wheel	2
	33-072-01	Tire, W26.5 x 14.00 - 12 4 Ply	2
	72-042-02	Wheel	2
27	42-040	Yoke End	4
	HNJ-34-16	Jam Nut, 3/4 - 16	4
28	72-099	Tailgate Lift Rod	2
29	72-177	Hopper Lift Safety	1
	HB-38-16-250	Hex Bolt, 3/8 - 16 x 2 1/2	2
	HNW-38-16	Wing Nut, 3/8 - 16	2
30	78-365	Adapter with Orifice	1
31	72-183	Guide Bumpers	2
32	72-198	PTO Hanger	1
NS	72-140	Boot (Connects vacuum hosing to reel deck)	1

Parts



IMPORTANT

Note: if you are using the 72-004 Over-The-Road Towing Package, use 72-159 Tire and Wheel.



CONTROL PANEL DRAWING

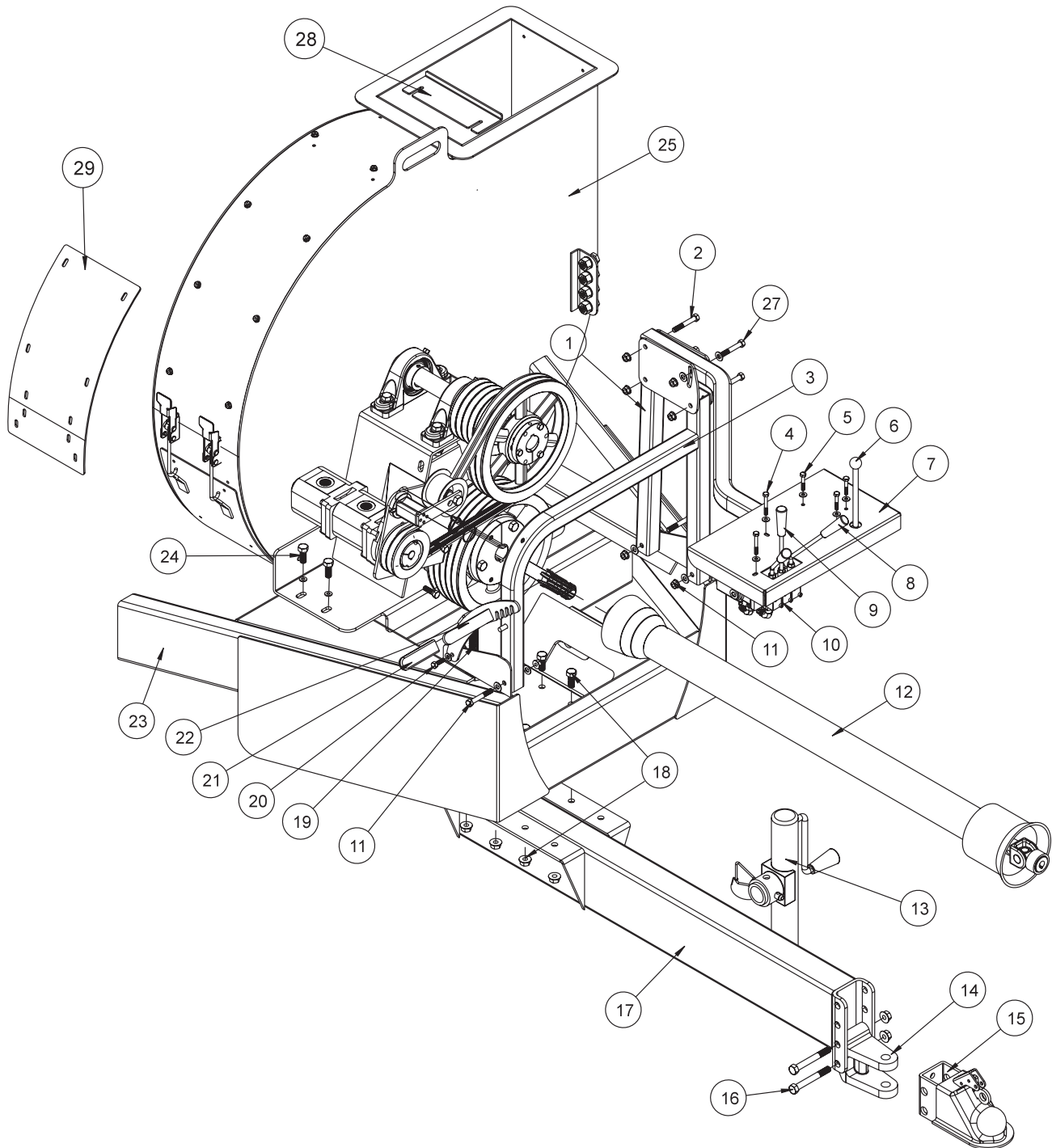

PARTS

CONTROL PANEL PARTS LIST

REF#	PART#	DESCRIPTION	QUANTITY
1	72-120	Adjustment Leg	1
2	HB-38-16-250	Hex Bolt, $\frac{3}{8}$ - 16 x 2 $\frac{1}{2}$	3
	HNTL-38-16	Nylon Lock Nut, $\frac{3}{8}$ - 16	3
3	72-121	Control Panel Leg	1
4	HB-14-20-200	Hex Bolt, $\frac{1}{4}$ - 20 x 2	2
	HW-14	Flat Washer, $\frac{1}{4}$	2
	HNFL-14-20	Flange Whiz-loc Nut, $\frac{1}{4}$ - 20	2
5	HB-14-20-150	Hex Bolt, $\frac{1}{4}$ - 20 x 1 $\frac{1}{2}$	3
	HW-14	Flat Washer, $\frac{1}{4}$	3
	HNFL-14-20	Flange Whiz-loc Nut, $\frac{1}{4}$ - 20	3
6	72-151	Hydraulic Valve	1
7	72-095	Control Panel	1
	72-054	Decal, Control Panel	1
8	78-418	Bent Handle	2
9	78-417	Straight Handle	1
10	78-416	3-Bank Hydraulic Valve	1
11	HB-38-16-250	Hex Bolt, $\frac{3}{8}$ - 16 x 2 $\frac{1}{2}$	3
	HW-38	Flat Washer, $\frac{3}{8}$	6
	HNTL-38-16	Nylon Lock Nut, $\frac{3}{8}$ - 16	3
12	72-202	PTO Shaft	1
13	78-240	Jack	1
14	78-244	$\frac{3}{4}$ Clevis	1
15	78-245	2 $\frac{5}{16}$ Ball Hitch (Optional)	1
16	HB-58-11-400	Hex Bolt, $\frac{5}{8}$ - 11 x 4	2
	HNCL-58-11	Center Nylon Lock Nut, $\frac{5}{8}$ - 11	2
17	72-086	Tongue	1
18	HB-12-13-125	Hex Bolt, $\frac{1}{2}$ - 13 x 1 $\frac{1}{4}$	8
	HNTL-12-13	Nylon Lock Nut, $\frac{1}{2}$ - 13	8
19	60-323	Spring	1
20	HB-516-18-100	Hex Bolt, $\frac{5}{16}$ - 18 x 1	1
	HW-516	Flat Washer, $\frac{5}{16}$	2
	HNTL-516-18	Nylon Lock Nut, $\frac{5}{16}$ - 18	1
21	15-020	Grip	1
22	72-093	Adjustment Lock Arm	1
23	72-080	Main Frame	1
24	HB-12-13-150	Hex Bolt, $\frac{1}{2}$ - 13 x 1 $\frac{1}{2}$	4
	HW-12	Flat Washer, $\frac{1}{2}$	4
	HNFL-12-13	Flange Whiz-loc Nut, $\frac{1}{2}$ - 13	4
25	72-181	Blower Housing	1
	78-436	Pipe Plug	1
26	72-119	Control Panel Adjustment Bracket	2
27	HB-38-16-275	Hex Bolt, $\frac{3}{8}$ - 16 x 2 $\frac{3}{4}$	1
	HW-38	Flat Washer, $\frac{3}{8}$	2
	HNTL-38-16	Nylon Lock Nut, $\frac{3}{8}$ - 16	1
28	72-175	Lining Holder	1
29	72-184	Wear Cover	1
30	72-198	PTO Hanger	1
	HB-38-16-225	Hex Bolt, $\frac{3}{8}$ - 16 x 2 $\frac{3}{4}$	1
	HNTL-38-16	Nylon Lock Nut, $\frac{3}{8}$ - 16	1

OIL TANK DRAWING

PARTS

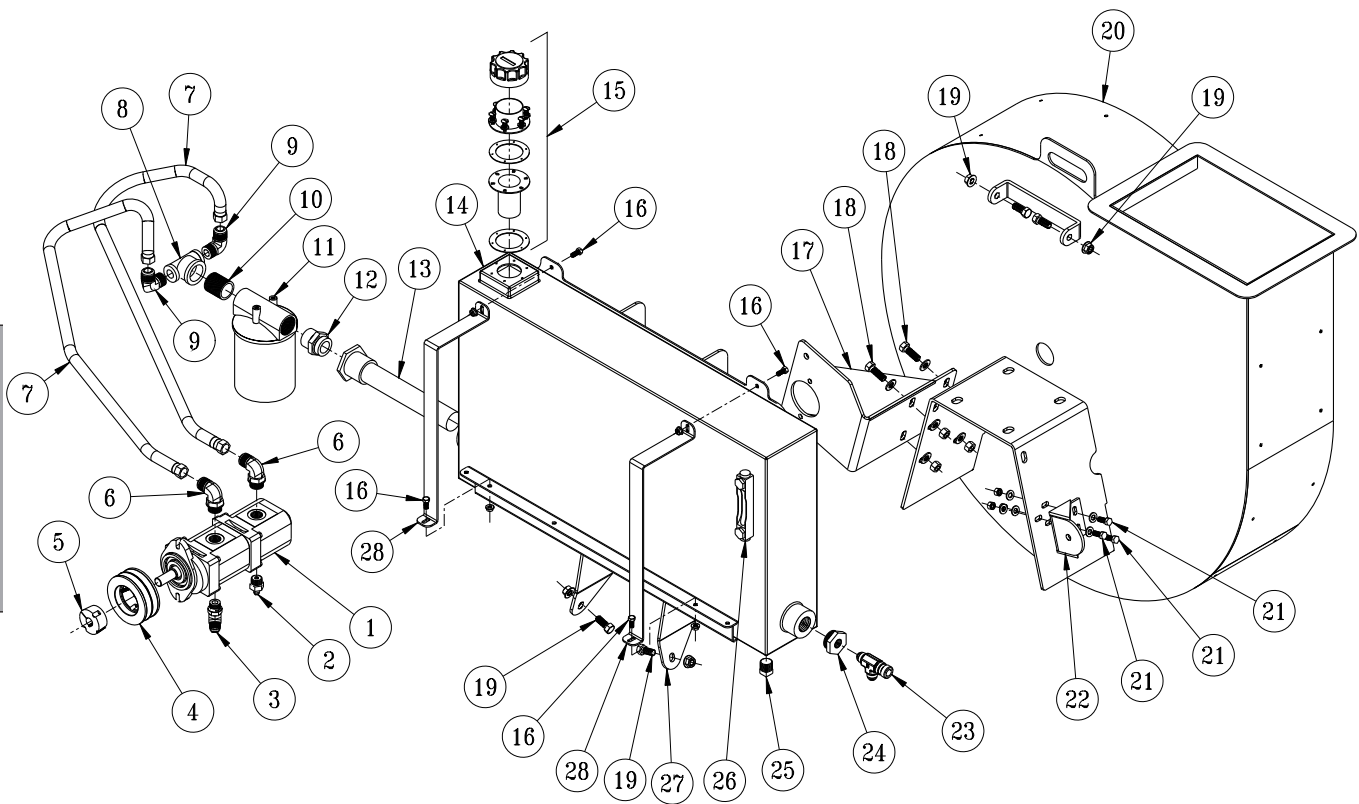

OIL TANK PARTS LIST

REF #	PART #	DESCRIPTION	QUANTITY
1†	72-185	Hydraulic Double Pump	1
	78-413-01	Front Pump Seal Kit	1
	72-185-01	Rear Pump Seal Kit	1
2	18-331	Adapter	1
3	18-265	Elbow	1
4	72-033	Pulley	1
5	78-237	Hub	1
	HSSHS-38-16-063	Set Screw, $\frac{3}{8}$ -16 x $\frac{5}{8}$ (part of 78-237)	2
	HWK-316-063	Woodruff Key	1
6	18-346	Elbow	2
7	72-079	Suction Hose	2
8	18-276	Tee	1
9	18-347	Male Elbow	2
10	18-160	Nipple	1
11	72-146	Oil Filter	1
	60-334	Filter Element (Replacement Only)	1
12	18-345	Straight Male Pipe Adapter	1
13*	72-041-01	Suction Strainer	1
14	72-041	Hydraulic Oil Tank (includes all * items)	1
15*	72-041-02	Filler / Breather	1
16	HB-38-16-075	Hex Bolt, $\frac{3}{8}$ -16 x $\frac{3}{4}$	4
	HNFL-38-16	Flange Whiz-loc Nut, $\frac{3}{8}$ -16	4
17	72-178	Hydraulic Motor Mount	1
18	HB-12-13-150	Hex Bolt, $\frac{1}{2}$ - 13 x $1\frac{1}{2}$	4
	HW-12	Washer $\frac{1}{2}$	8
	HNTL-12-13	Nylon Lock Nut, $\frac{1}{2}$ - 13	4
19	HB-12-13-125	Hex Bolt, $\frac{1}{2}$ - 13 x $1\frac{1}{4}$	4
	HNFL-12-13	Flange Whiz-loc Nut, $\frac{1}{2}$ -13	4
20	72-181	Blower Housing	1
	78-436	Pipe Plug	1
21	HB-38-16-100	Hex Bolt, $\frac{3}{8}$ -16 x 1	3
	HW-38	Flat Washer, $\frac{3}{8}$	6
	HNTL-38-16	Nylon Lock Nut, $\frac{3}{8}$ -16	3
22	72-179	Tensioner Bracket	1
23	18-447	Run Tee	1
24	18-315	Reducer Bushing	1
25*	72-041-04	Magnetic Drain Plug	1
26*	72-041-03	Sight Gauge	1
27	72-201	Tank Cradle	1
28	72-200	Tank Strap	2

† No other parts are replaceable for hydraulic tank

BLOWER HOUSING DRAWING

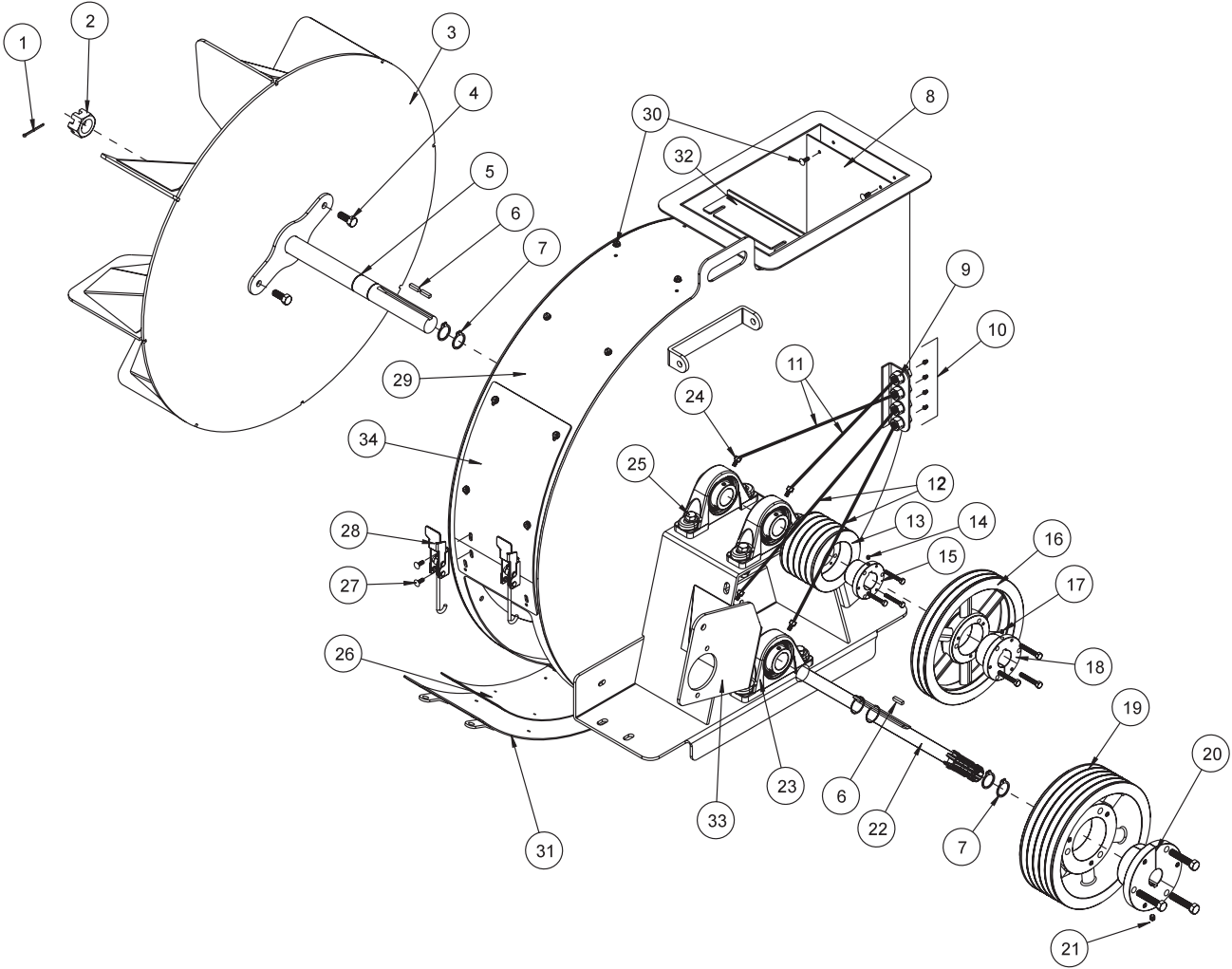

BLOWER HOUSING PARTS LIST

REF#	PART#	DESCRIPTION	QUANTITY
1	HP-18-200	Cotter Pin, 1/8 x 2	1
2	HNA-114-12	Axle Nut, 1 1/4 - 12	1
3	72-083	Balanced Fan	1
4	HB-12-13-125	Hex Bolt, 1/2 - 13 x 1 1/4	2
	HNTL-12-13	Nylon Lock Nut, 1/2 - 13	2
5	72-094	Blower Shaft	1
6	HKSQ-14-100	Square Key, 1/4 x 1/4 x 1	3
7	HRR-150	Retaining Ring, 1 1/2	4
8	72-156	Blower Lining, 9 x 62	1
9	18-339	Anchor Coupling	4
	18-338	Male Connector	4
10	HG-18-180	Grease Fitting, 1/8 x 180°	4
11	72-126	Brake Line, 3/16 x 24"	2
12	72-127	Brake Line, 3/16 x 30"	2
13	72-029	Pulley	1
14	HSSHS-14-20-025	Set Screw, 1/4 - 20 x 1/4 (comes with 72-030)	1
15	72-030	Hub	1
16	72-027	Pulley	1
17	HSSHS-14-20-025	Set Screw, 1/4 - 20 x 1/4 (comes with 72-028)	1
18	72-028	Hub	1
19	72-031	Pulley	1
20	72-032	Hub	1
21	HSSHS-38-16-038	Set Screw, 3/8 - 16 x 3/8 (comes with 72-032)	1
22	72-060	Keyed PTO Shaft	1
23	72-203	Pillow Blocks	4
24	18-338	Male Connector	4
25	HB-58-11-250	Hex Bolt, 5/8 - 11 x 2 1/2	8
	HMB-34-10	Machine Bushing, 3/4 x 10GA	4
	HW-58	Flat Washer, 5/8	8
	HNTL-58-11	Nylon Lock Nut, 5/8 - 11	8
26	72-158	Trap Door Lining	1
27	HSTP-14-20-075	Phillip Head Machine Screw, 1/4 - 20 x 3/4	4
	HNTL-14-20	Nylon Lock Nut, 1/4 - 20	4
28	48-115	Adjustable Draw Latch	2
29	72-181	Blower Housing	1
	72-157	Blower Lining, 9 x 41"	1
	78-436	Plug	1
30	HSTP-14-20-075	Phillip Head Machine Screw 1/4 - 20 x 3/4	34
	HNTL-14-20	Nylon Lock Nut, 1/4 - 20	34
31	72-196	Blower Housing Access Door	1
	72-197	Door Pivot	1
32	72-175	Lining Holder	1
33	72-178	Hydraulic Motor Mount	1
	HB-12-13-150	Hex Bolt, 1/2 - 13 x 1 1/2	4
	HW-12	Flat Washer, 1/2	8
	HNTL-12-13	Nylon Lock Nut, 1/2 - 13	4
34	72-184	Wear Cover	1

VACUUM HOUSING, BELTS AND TENSIONER DRAWING

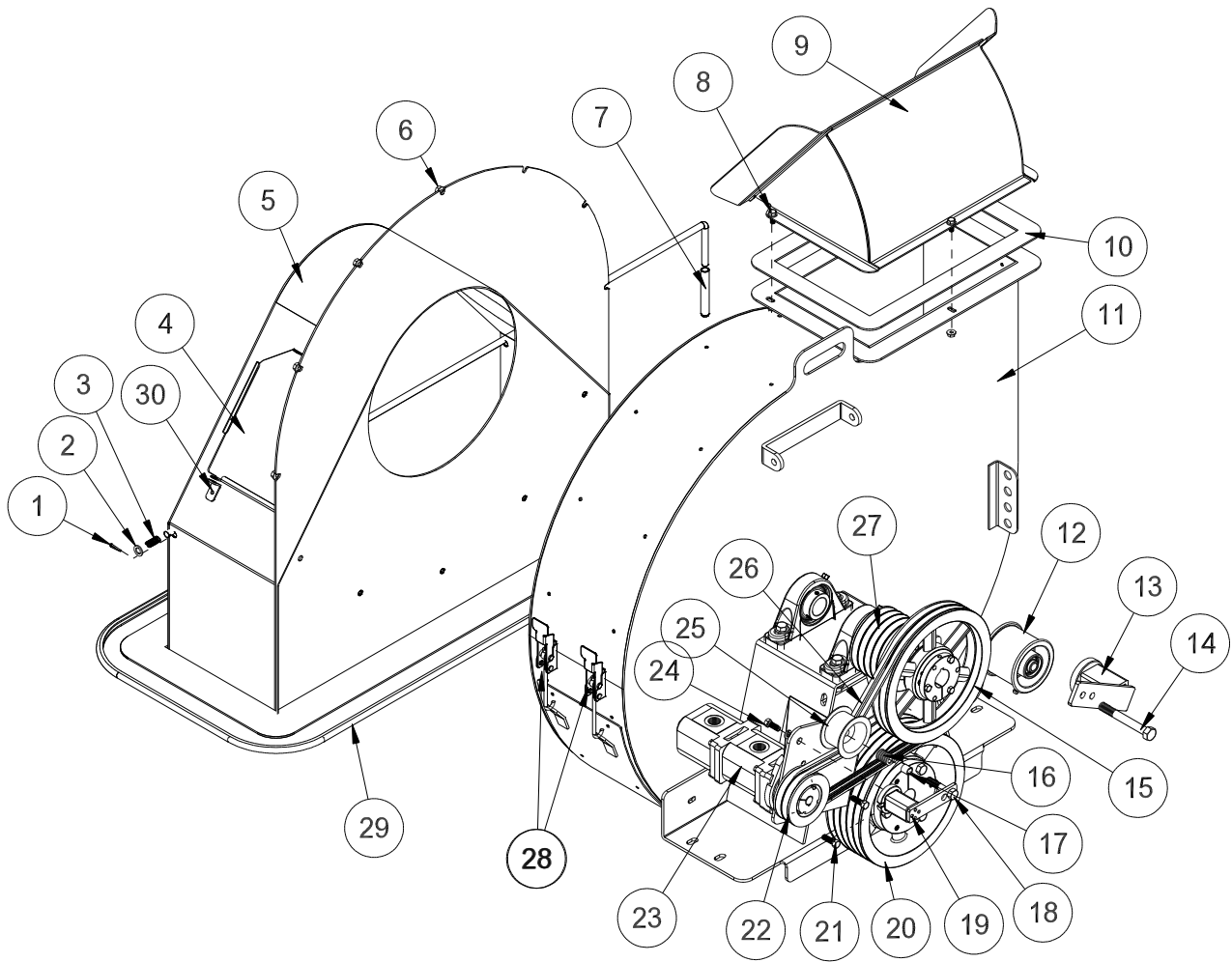

Parts

VACUUM HOUSING, BELTS AND TENSIONER PARTS LIST

REF#	PART#	DESCRIPTION	QUANTITY
1	HP-18-100	Cotter Pin, 1/8 x 1	1
2	HMB-12-14	Machine Bushing, 1/2 x 14GA	1
3	72-132	Spring	1
4	78-293	Cover Plate	2
5	72-081	Vacuum Housing	1
6	HNFL-516-18	Flange Whiz-loc Nut, 5/16 -18	12
	HBFL-516-18-075	Flange Hex Bolt, 5/16 - 18 x 3/4	12
7	25-120	Handle Grip	1
8	HBFL-516-18-075	Flange Hex Bolt, 5/16 -18 x 3/4	3
	HNFL-516-18	Flange Whiz-loc Nut, 5/16 - 18	3
9	72-109	Blower Chute	1
	72-131	Blower Chute Lining, 10 1/2 x 15 1/2	1
	HSTP-14-20-075	Phillip Head Machine Screw, 1/4 -20 x 3/4	6
	HNFL-14-20	Flange Whiz-loc Nut, 1/4 - 20	6
10	8828-60	Foam Tape	1
11	72-181	Blower Housing	1
	78-436	Pipe Plug	1
12	72-050	Idler Pulley	1
	72-050-01	Bearing	2
13	72-147	Tensioner	1
	HBM-12-1.75-40	Metric Hex Bolt, 12 - 1.75 x 40 (comes with 72-025)	1
	HWLM-12	Metric Lock Washer, 12 (comes with 72-025)	1
14	HB-58-11-500	Hex Bolt, 5/8 - 11 x 5	1
	HNTL-58-11	Nylon Lock Nut, 5/8 - 11	1
15	72-027	Pulley	1
	72-028	Hub	1
16	HMB-12-14	Machine Bushing, 1/2 x 14GA	6
17	76-275	Spacer (comes with 78-224)	1
18	HB-12-13-250	Hex Bolt, 1/2 - 13 x 2 1/2 (comes with 78-224)	1
	HNCL-12-13	Center Nylon Lock Nut, 1/2 - 13 (comes with 78-224)	1
19	78-224	Tensioner	1
20	72-031	Pulley	1
	72-032	Hub	1
21	HB-38-16-125	Hex Bolt, 3/8 - 16 x 1 1/4	2
	HNFL-38-16	Flange Whiz-loc Nut, 3/8 - 16	2
22	72-033	Pulley	1
	78-237	Hub	1
23	72-185	Hydraulic Double Pump	1
24	HBM-10-1.50-30	Metric Hex Bolt, 10 - 1.5 x 30 (comes with 78-224)	1
	HWLM-10	Metric Lock-washer, 10 (comes with 78-224)	1
25	16-013	Idler Pulley	1
26	72-036	Belt, 5V x 540	2
27	72-029	Pulley	1
	72-030	Hub	1
	72-036	Belt, 5V x 540	5
28	48-115	Draw Latch	2
29	8803-114	Trim Black	1
30	78-433	Cover Plate Hex Bolt Tab	2
	HB-14-20-075	Hex Bolt, 1/4 -20 x 3/4	4
	HNTL-14-20	Nylon Lock Nut, 1/4 - 20	4

HOPPER DRAWING

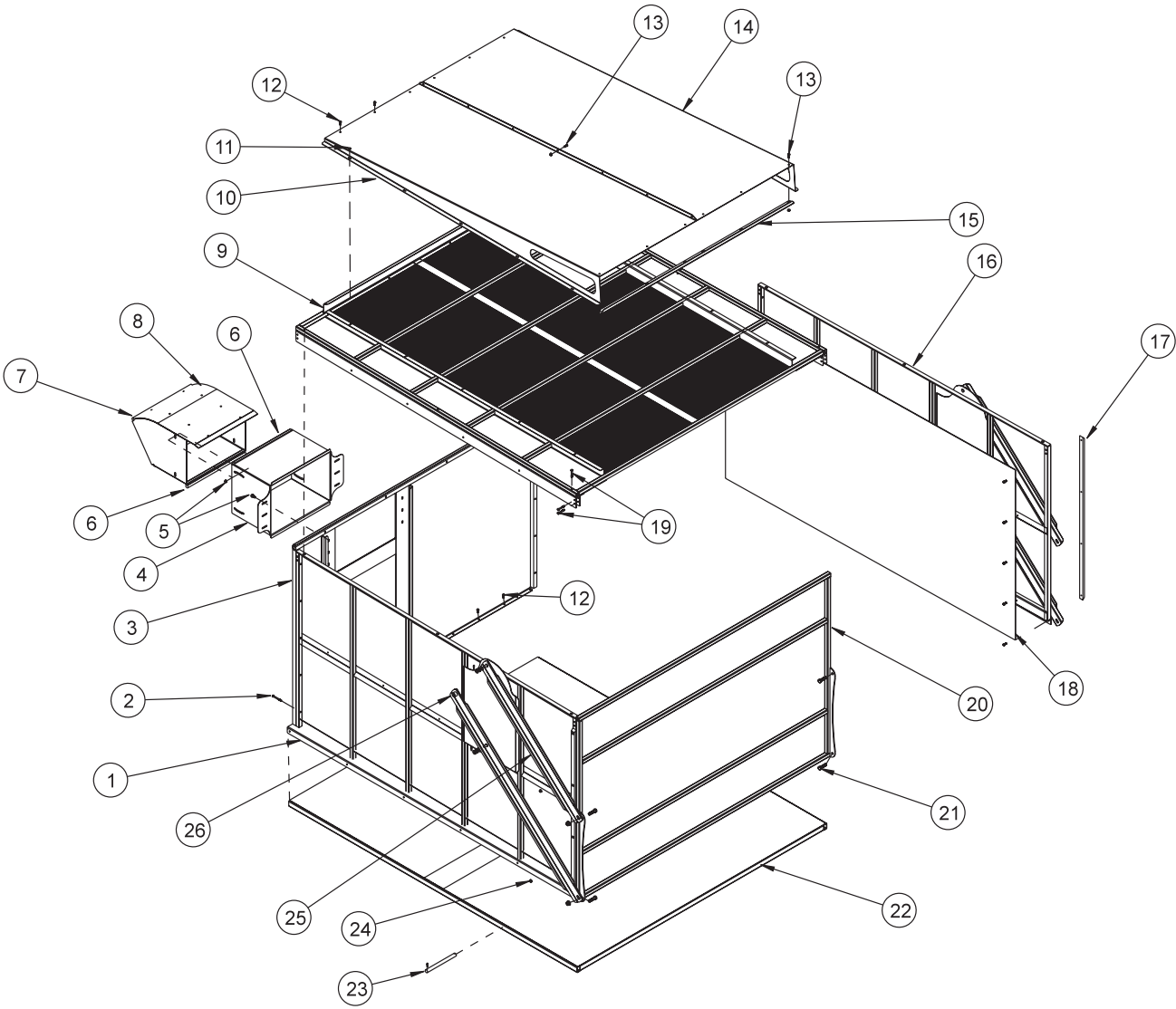

Parts

HOPPER PARTS LIST

REF #	PART #	DESCRIPTION	QUANTITY
1	72-106	Left Hopper Side Frame	1
2	HB-14-20-250	Hex Bolt, 1/4 -20 x 2 1/2	15
	HNFL-14-20	Flange Whiz-loc Nut, 1/4 -20	15
3	72-115	Hopper Front	1
	HSDPS-14-075	Stainless Pan Head Drill Screw, 1/4 x 3/4	9
4	72-110	Hopper Chute	1
	72-145	Hopper Chute Lining	1
	HSTP-14-20-075	Phillip Head Machine Screw, 1/4 -20 x 3/4	6
	HNFL-14-20	Flange Whiz-loc Nut, 1/4 - 20	6
5	HBFL-516-18-075	Flange Hex Bolt, 5/16 -18 x 3/4	10
	HNFL-516-18	Flange Whiz-loc Nut, 5/16 -18	10
6	8947-36	Trim Seal	2
7	8980-60	Edge Seal	1
8	72-111	Middle Chute	1
9	72-107	Hopper Top	1
10	72-102	Left Hopper Cover	1
11	HW-14	Flat Washer, 1/4	10
12	HSDPS-14-075	Stainless Pan Head Drill Screw 1/4 x 3/4	6
13	HB-14-20-075	Hex Bolt, 1/4 -20 x 3/4	23
	HNFL-14-20	Flange Whiz-loc Nut, 1/4 -20	23
14	72-101	Right Hopper Cover	1
15	72-124	Hood Stiffener	1
16	72-105	Right Hopper Side Frame	1
17	72-138	Slide Strip	2
	HRS-316-075	Pop Rivet, 3/16	8
18	72-137	Hopper Side	2
	HSDPS-14-075	Stainless Pan Head Drill Screw 1/4 x 3/4	82
19	HB-14-20-175	Hex Bolt, 1/4 -20 x 1 3/4	14
	HNFL-14-20	Flange Whiz-loc Nut, 1/4 - 20	14
20	72-116	Tailgate	1
21	HB-12-13-175	Hex Bolt, 1/2 -13 x 1 3/4	4
	HNFL-12-13	Flange Whiz-loc Nut, 1/2 - 13	4
22	72-098	Hopper Floor	1
23	72-123	Pivot Pin	2
	HP-18-100	Cotter Pin, 1/8 x 1	4
24	HSTP-14-20-075	Phillip Head Machine Screw 1/4 -20 x 3/4	18
	HNFL-14-20	Flange Whiz-loc Nut, 1/4 - 20	18
25	72-118	Short Tailgate Lift Arm	2
	18-234	Bushing (part of 72-118)	1
	HMB-12-14	Machine Bushing, 1/2 x 14 GA	6
	HP-18-100	Cotter Pin, 1/8 x 1	2
26	72-117	Long Tailgate Lift Arm	2
	18-234	Bushing (part of 72-117)	2
	HMB-12-14	Machine Bushing, 1/2 x 14 GA	6
	HP-18-100	Cotter Pin, 1/8 x 1	2

72-151 HYDRAULIC VALVE DRAWING

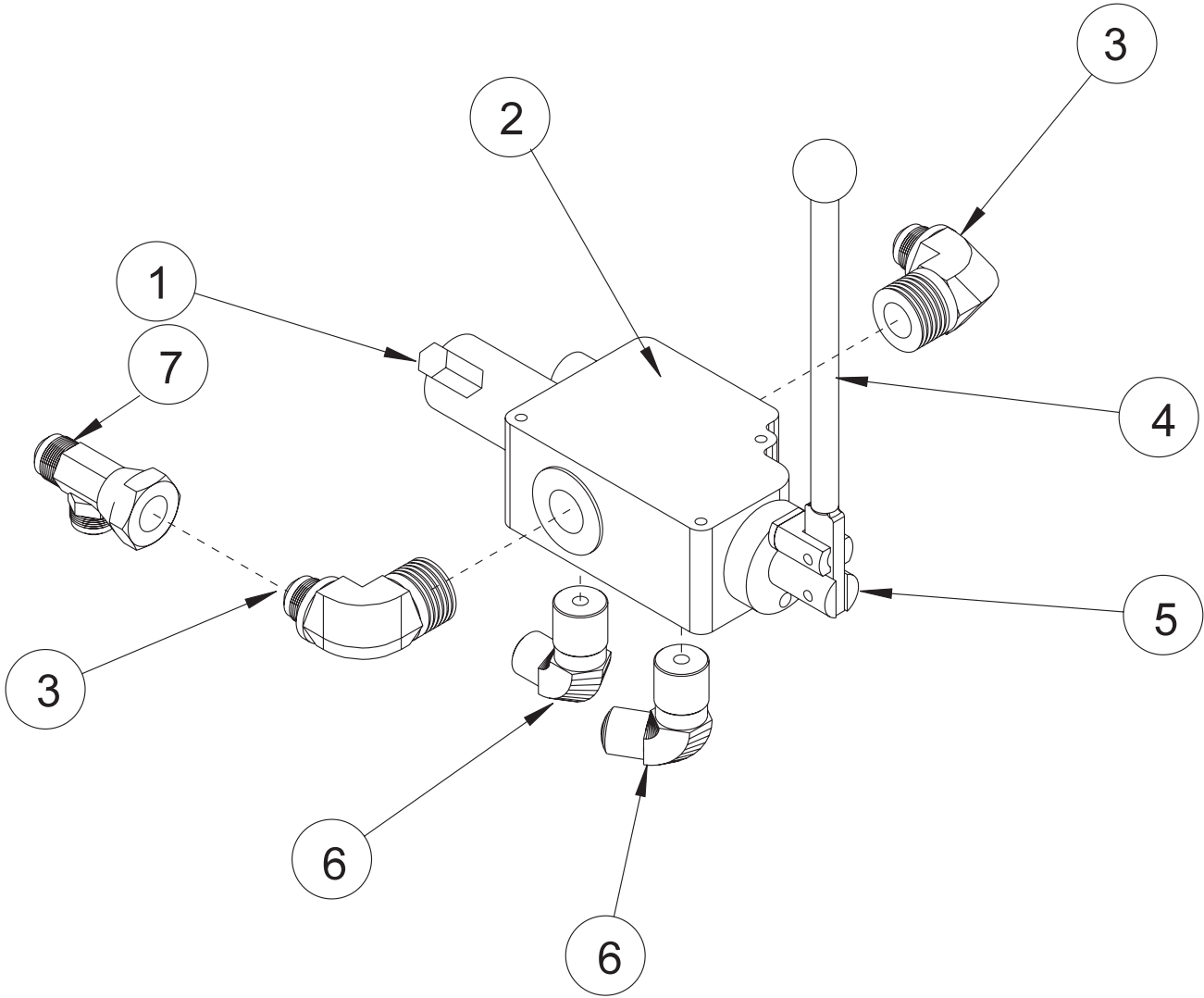

72-151 HYDRAULIC VALVE PARTS LIST

REF#	PART#	DESCRIPTION	QUANTITY
1*	33-066-27	Detent Housing	1
	33-066-17	Detent Plunger	1
	33-066-29	Spring	1
	33-066-19	Set Screw, $\frac{5}{16}$ – 24 x $\frac{3}{8}$	1
	33-066-18	Washer	1
	2	72-151	Hydraulic valve
3	18-244	Male Elbow	2
4*	72-151-01	Valve Handle Kit	1
	33-066-08	Ball Knob	1
5*	33-066-02	Spool	1
	33-066-05	Quad Ring	2
	33-066-06	Wiper	2
6	18-246	Male Elbow	2
7	18-337	Run Tee	1
NS	72-207	Valve Handle Stop	1
*	72-151	Hydraulic Valve, 2800 psi, 190 Bars (includes all * items)	

78-416 3-BANK HYDRAULIC VALVE DRAWING

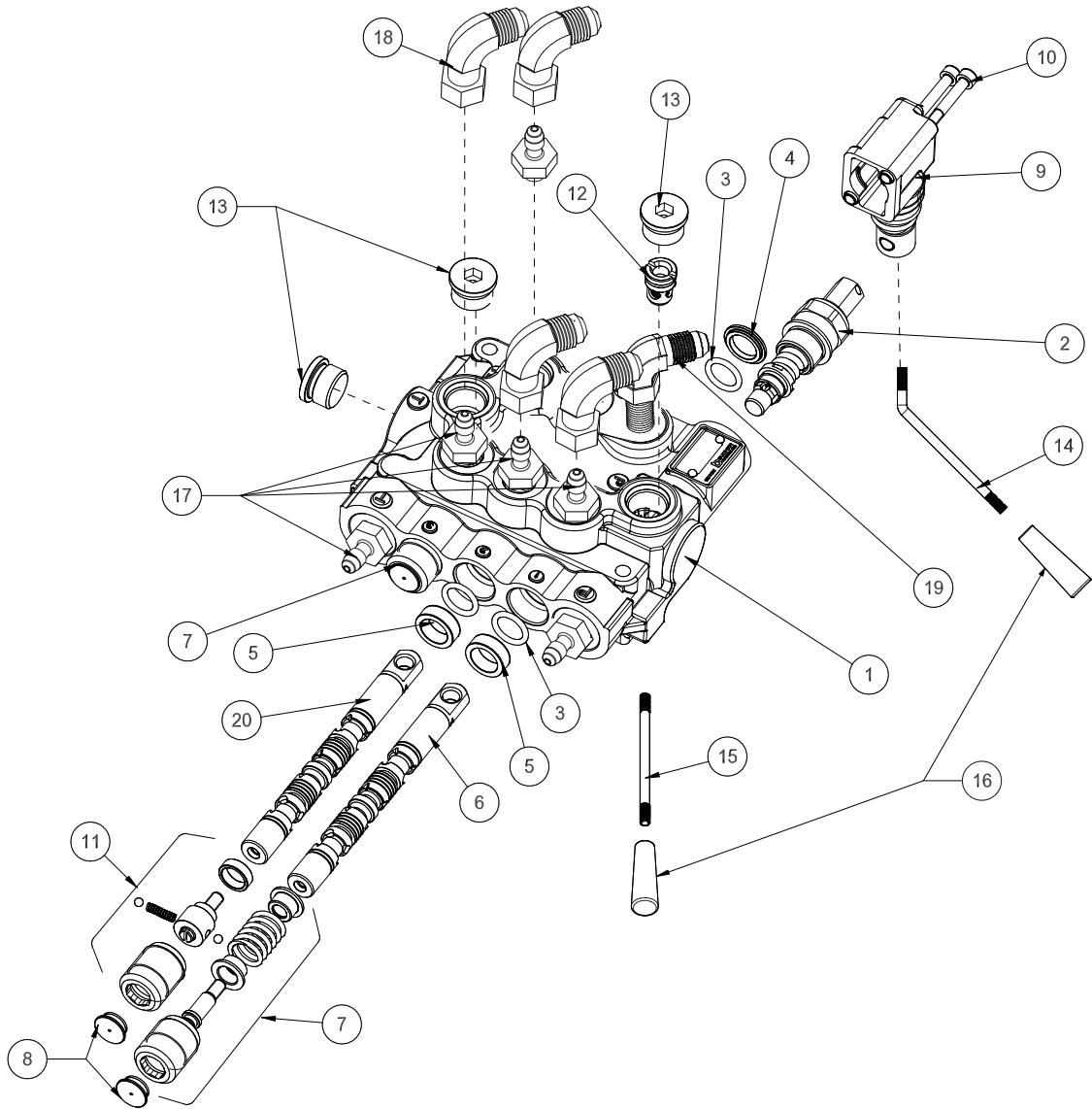

Parts

78-416 3-BANK HYDRAULIC VALVE PARTS LIST

REF#	PART#	DESCRIPTION	QUANTITY
1*	78-416-01	Body (complete with spacer and check valve)	1
2*	78-415-02	Spool HDM10	1
3*	78-415-03	O-Ring Seal	6
4*	78-415-04	Flanged Washer HDM10	3
5*	78-415-05	Spacer	3
6*	78-415-06	A Type Spool HDS11	2
7*	78-415-11	Positioner HDM10	2
8*	78-415-08	Plug	3
9*	78-415-09	Lever Group HDS11	3
10*	78-415-10	Metric Socket Screw M5 x .8 x 45	6
11*	78-415-07	Positioner	1
12*	78-415-12	Check Valve Assembly HDM12	1
13*	78-415-13	³ / ₄ - 16 SAE 8 Screw Plug	3
14	78-418	Bent Handle	2
15	78-417	Straight Handle (center)	1
16	78-417-01	Tapered Knob	3
17	18-169	Adapter SAE ³ / ₈	6
18	18-202	Elbow	4
19	18-168	Elbow 3/8 Straight Thread	1
20		C- Type Spool	1
* 78-416		3 – Bank Hydraulic Valve (includes all * items)	

AXLE DRAWING

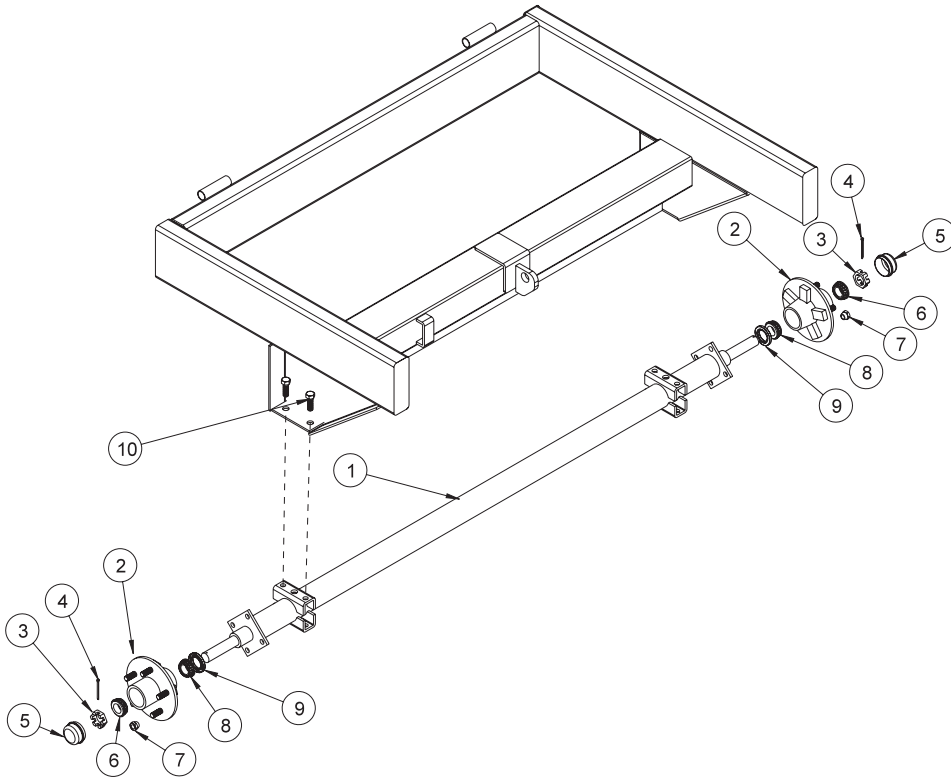

72-202 PTO SHAFT DRAWING

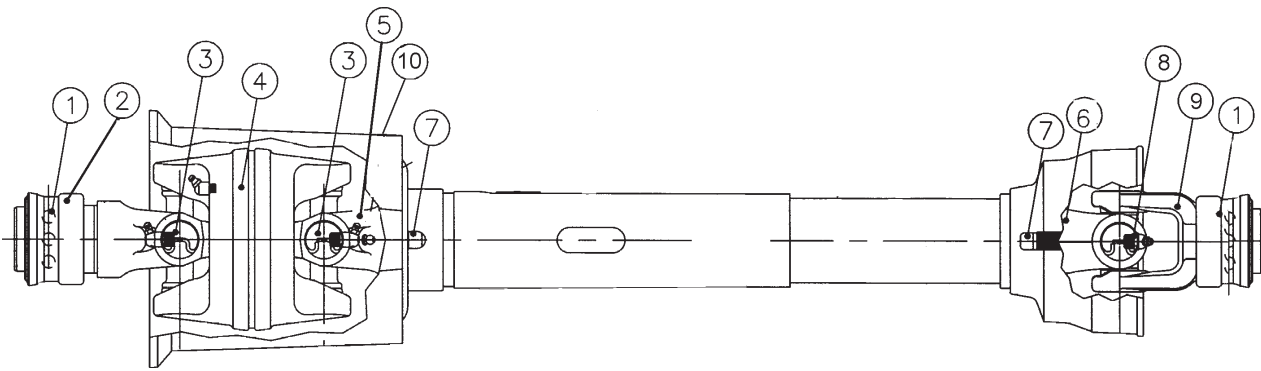

Tractor End

V72 Machine End

AXLE PARTS LIST

REF #	PART #	DESCRIPTION	QUANTITY
1	72-194	Axle (includes all items listed below except #10)	1
2	33-074	Hub Assembly (includes all * items listed below)	2
3	HNAR-100-14	Slotted Jam Nut, 1-14	2
4	HP-18-200	Cotter Pin, 1/8 x 2	2
5*	33-073-02	Dust Cap	2
6*	78-119	Outer Bearing	2
7*	HNL-12-20	Lug Nut	10
8*	78-118	Inter Bearing	2
9*	33-073-01	Grease Seal	2
10	HB-12-13-125	Hex Bolt, 1/2 - 13 x 1 1/4	4
	HNTL-12-13	Nylon Lock Nut, 1/2 - 13	4

 **IMPORTANT**

NOTE: If using the 72-004 Over-The-Road Towing Package, order Hub Assembly Part Number 72-162. Seals, bearings and cap are the same part numbers.

72-202 PTO SHAFT PARTS LIST

REF#	PART#	DESCRIPTION	QUANTITY
1	72-055-01	Spring - Lok Repair Kit	2
2	72-202-02	Spring - Lok Yoke Assembly	1
3	72-202-03	Cross and Bearing Kit	2
4	72-202-04	CV Center Housing Assembly	1
5	72-202-05	Yoke and Shaft	1
6	72-055-07	Yoke, Tube and Slip Sleeve	1
7		Nylon Repair Kit	2
8	72-055-08	Cross and Bearing Kit	1
9	72-055-09	Spring - Lok Yoke Assembly	1
10	72-017-01	Outside Plastic Protection Sleeve	1
	72-202-01	Shaft Half with Guard Set	
	72-087	Decal, Tracotr PTO	1

72-001 COMBINATION SWEEPER - VERTICUT HEAD DRAWING

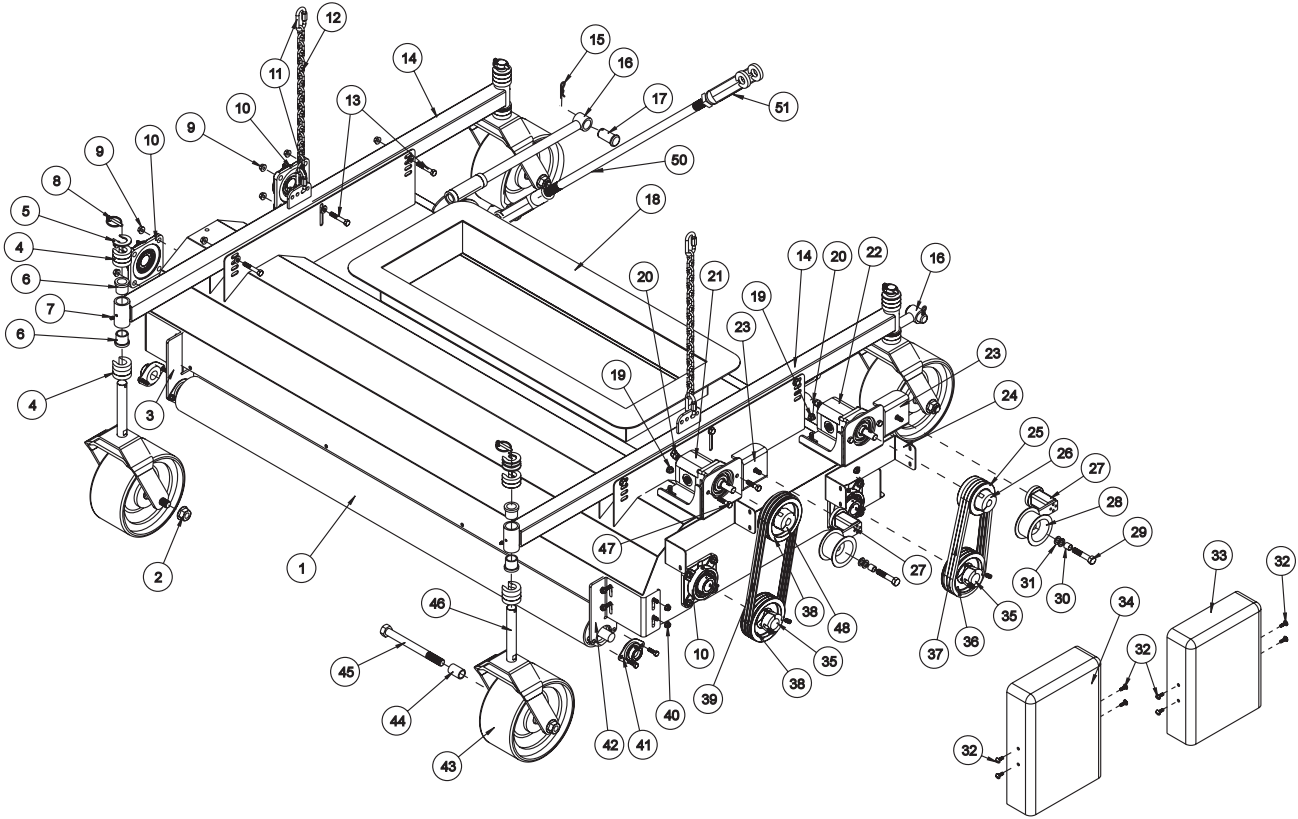

Accessories

72-001 COMBINATION SWEEPER - VERTICUT HEAD PARTS LIST

REF#	PART#	DESCRIPTION	QUANTITY
1	72-090	Anti-Scalp Roller	1
2	HNTL-34-10	Nylon Lock Nut, $\frac{3}{4}$ - 10	4
3	72-113	Left Roller Bracket	1
4	72-053	Quick Spacer, $\frac{1}{2}$ "	20
5	72-136	Quick Spacer 10GA	12
6	18-223	Flange Bushing (part of 72-112)	8
7	HG-14-28-180	Grease Fitting, $\frac{1}{4}$ - 28 x 180° (part of 72-112)	4
8	42-539	Lynch Pin, $\frac{5}{16}$	4
9	HB-38-16-125	Hex Bolt, $\frac{3}{8}$ - 16 x $1\frac{1}{4}$	16
	HNFL-38-16	Flange Whiz-loc Nut, $\frac{3}{8}$ - 16	16
10	72-023	Flange Bearing	4
	HG-14-28-180	Grease Fitting, $\frac{1}{4}$ - 28 x 180° (part of 72-023)	4
11	72-100	$\frac{5}{16}$ Chain Connector	4
12	8820-16	Machine Chain Straight Link	2
13	HB-38-16-275	Hex Bolt, $\frac{3}{8}$ - 16 x $2\frac{3}{4}$	6
	HW-38	Flat Washer, $\frac{3}{8}$	6
	HNFL-38-16	Flange Whiz-loc Nut, $\frac{3}{8}$ - 16	6
14	72-112	Castor Wheel Arm	2
15	HHP-.177	Bridge Pin, .177 x 3.75	4
16	72-103	Reel Lift Rod	2
17	HCP-100-250	Clevis Pin, 1 x 2	4
18	72-085	Reel Housing	1
	8803-114	Trim Black with Lace	1
19	HB-38-16-100	Hex Bolt, $\frac{3}{8}$ - 16 x 1	8
	HW-38	Flat Washer, $\frac{3}{8}$	8
	HNFL-38-16	Flange Whiz-loc Nut, $\frac{3}{8}$ - 16 x 1	8
20	18-362	Straight Thread Reducer	2
21*	72-187	Hydraulic Motor (thatcher reel)	1
22*†	72-199	Hydraulic Motor (finger reel)	1
23	72-097	Motor Mount	2
24	72-058	Belt Guard Mount	2
	HB-516-18-075	Hex Bolt, $\frac{5}{16}$ - 18 x $\frac{3}{4}$	4
	HW-516	Flat Washer, $\frac{5}{16}$	4
	HNFL-516-18	Flange Whiz-loc Nut, $\frac{5}{16}$ - 18	4
25	78-424	Pulley	1
26	78-428	$\frac{3}{4}$ " Hub	1
27	78-224	Belt Tensioner	2
	HBM-10-1.50-30	Metric Hex Bolt, 10 - 1.5 x 30 (comes with 78-224)	1
	HWLM-10	Metric Lock Washer, 10 (comes with 78-224)	1
28	16-013	Idler Pulley	2
29	HB-12-13-250	Hex Bolt, $\frac{1}{2}$ - 13 x $2\frac{1}{2}$ (part of 78-224)	2
	HNCL-12-13	Center Nylon Lock Nut, $\frac{1}{2}$ - 13 (part of 78-224)	2
30	76-275	Spacer (part of 78-224)	2

(Continued on next page)

*	72-199-01	Seal Kit	1 per
*†	HWK-316-063	Woodruff Key, $\frac{3}{16}$ x $\frac{5}{8}$	1 per

No other parts are replaceable for hydraulic motors.

72-001 COMBINATION SWEEPER - VERTICUT HEAD DRAWING

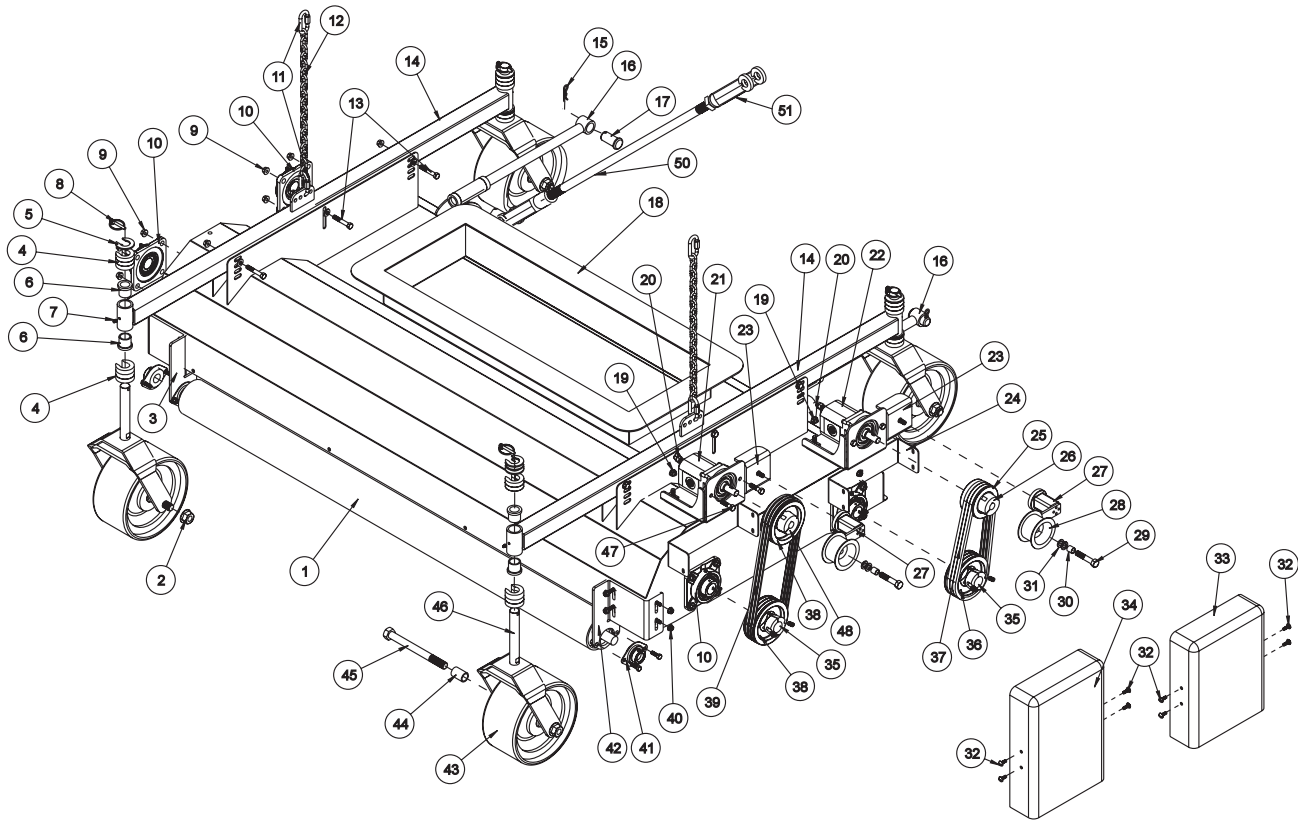

Accessories

72-001 COMBINATION SWEEPER - VERTICUT HEAD PARTS LIST

REF#	PART#	DESCRIPTION	QUANTITY
31	HMB-12-14	Machine Bushing, 1/2 x 14GA	4
32	HSTP-14-20-075	Phillip Machine Screw, 1/4 - 20 x 3/4	8
	78-274	Cage Nut	8
33	72-056	Belt Guard, 13"	1
34	72-057	Belt Guard, 15"	1
35	78-431	1 1/4 Hub	2
36	78-425	Pulley	1
37	72-038	Belt	3
38	78-430	Pulley	2
39	72-037	Belt	3
40	HB-516-18-075	Hex Bolt, 5/16 - 18 x 3/4	8
	HW-516	Flat Washer, 5/16	8
	HNFL-516-18	Flange Whiz-loc Nut, 5/16 - 18	8
41	13-391	1" Flange Bearing	2
	HB-516-18-100	Hex Bolt, 5/16 - 18 x 1	4
	HWL-516	Lock Washer, 5/16	4
	HN-516-18	Nut, 5/16 - 18	4
42	72-114	Right Roller Bracket	1
43	78-012	Tire and Wheel	4
	78-012-01	Bearing (part of 78-012)	4
44	72-135	Castor Wheel Spacer	8
45	HB-34-10-800	Hex Bolt, 3/4 - 10 x 8	4
46	72-134	Castor Fork	4
47	HB-38-16-125	Hex Bolt, 3/8 - 16 x 1 1/4	4
	HW-38	Flat Washer, 3/8	4
	HNTL-38-16	Nylon Lock Nut, 3/8 - 16	4
48	42-246	Hub	1
50	72-148	Sway Bar	1
51	42-040	Yoke End	2
	HNJ-34-16	Jam Nut, 3/4 - 16	2
	HCP-34-200	Clevis Pin, 3/4 x 2	2
	HHP-18	Bridge Pin, 1/8	2

(Continued on next page)

72-001 COMBINATION SWEEPER - VERTICUT REEL DRAWING

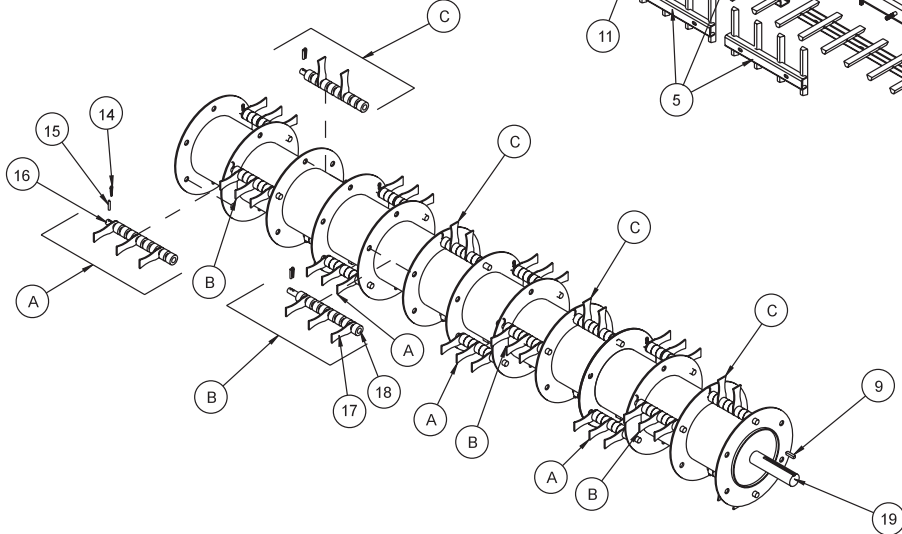
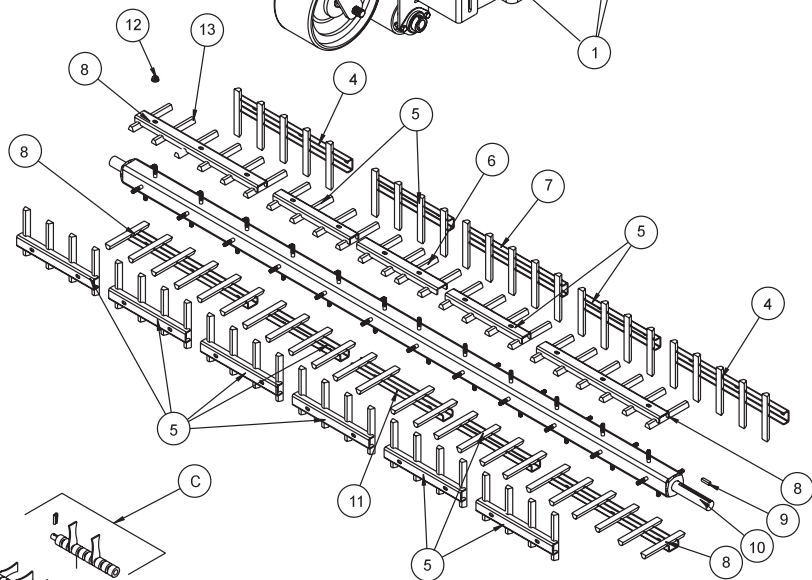
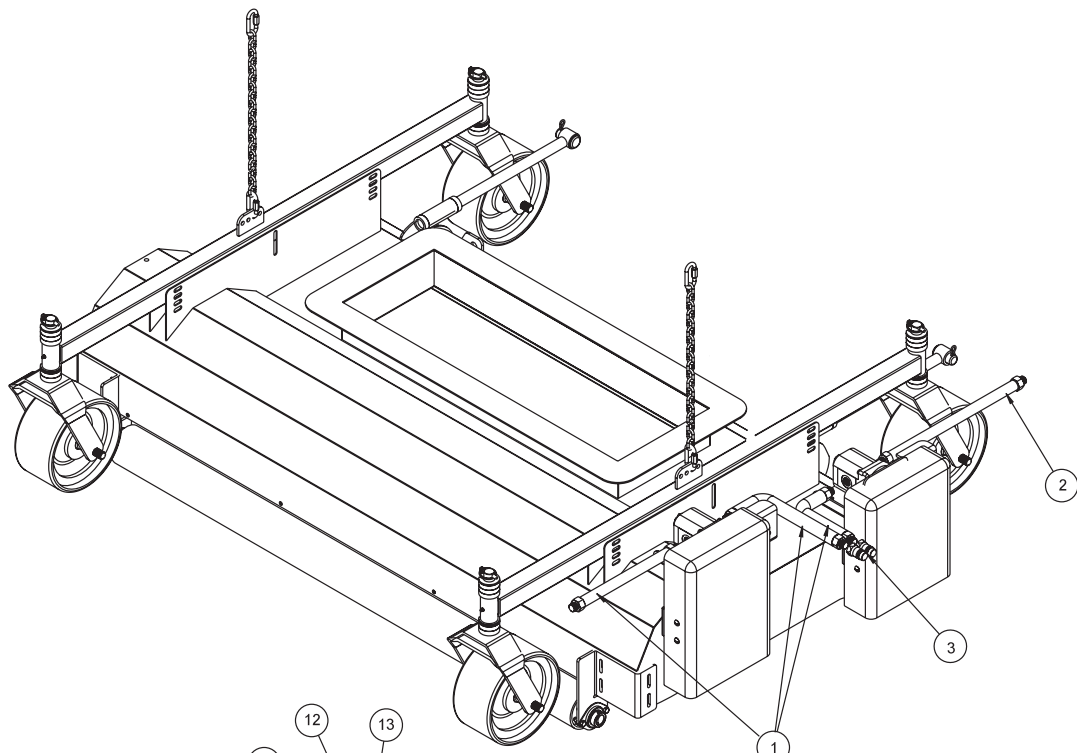

Accessories

72-001 COMBINATION SWEEPER - VERTICUT REEL PARTS LIST

REF#	PART#	DESCRIPTION	QUANTITY
1	72-074	Hydraulic Hose, 39"	3
2	72-075	Hydraulic Hose, 48"	1
3	72-043	1/2 Male Quick Coupler	2
4	72-091	Finger Clamp, 14 ³ / ₄ "	2
5	78-297	Finger Clamp, 10"	12
6	78-327	Finger Clamp, 10 ¹ / ₂ "	1
7	78-287	Finger Clamp, 13"	1
8	72-092	Finger Clamp, 16"	4
9	HKSQ-14-100	Square Key, 1/4 x 1/4 x 1	2
10	72-125	Finger Reel	1
11	78-326	Finger Clamp, 12"	1
12	HNFL-516-18	Flange Whiz-loc Nut, 5/16 - 18	48
13	8969-5.250	Sweeper Finger	96
14	HP-316-100	Cotter Pin, 3/16 x 1	24
15	HRP-316-100	Roll Pin, 3/16 x 1	24
16	72-104	Blade Rod	24
17	72-039	Flail Blade	66
18	72-051	Spacer	192
19	72-122	Thatch Reel Balanced	1

72-002 RUBBER FINGER SWEEPER HEAD DRAWING

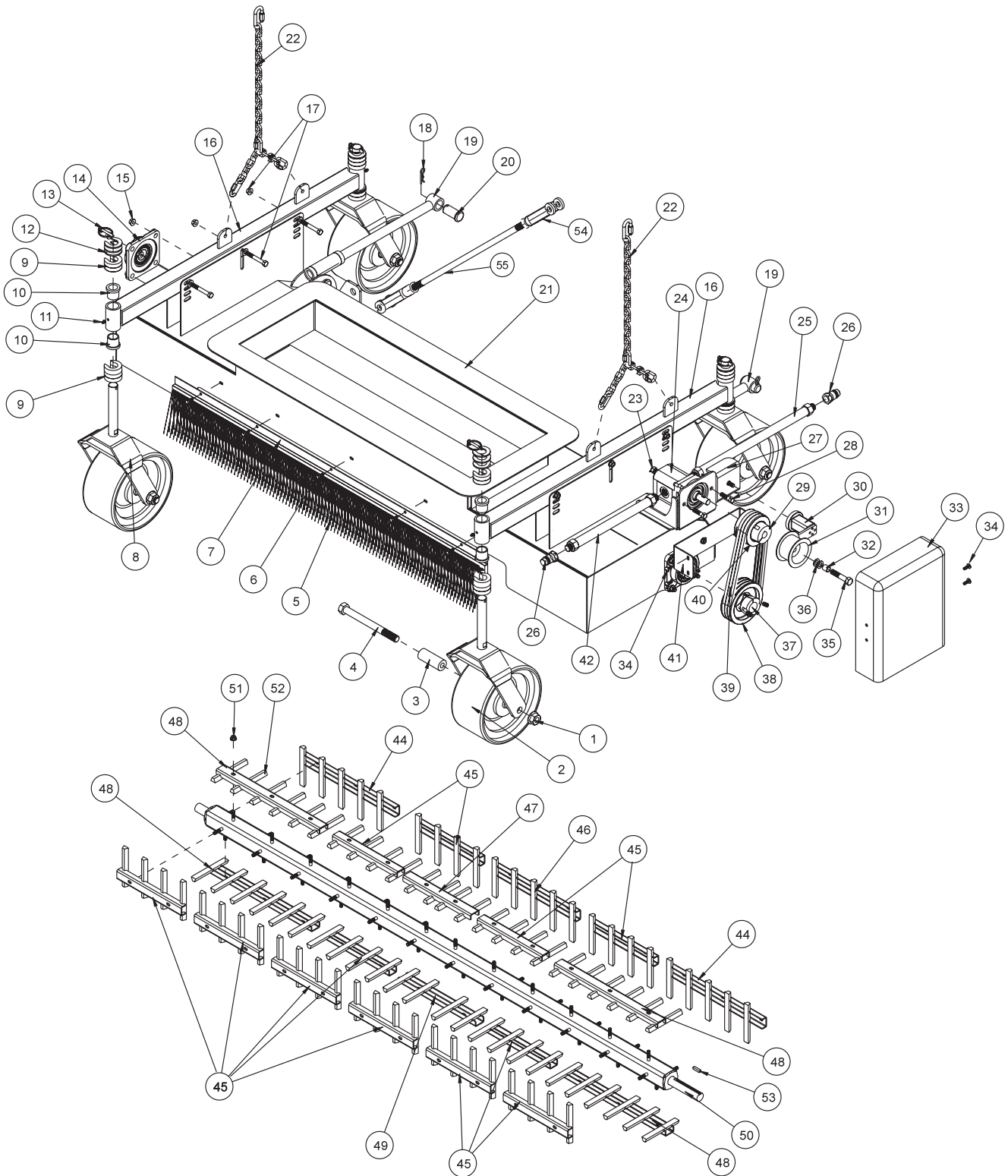

Accessories

72-002 RUBBER FINGER SWEEPER HEAD PARTS LIST

REF#	PART#	DESCRIPTION	QUANTITY
1	HNTL-34-10	Nylon Lock Nut, $\frac{3}{4}$ - 10	4
2	78-012	Tire and Wheel	4
	78-012-01	Bearing (part of 78-012)	2 per Wheel
3	72-135	Castor Wheel Spacer	8
4	HB-34-10-800	Hex Bolt, $\frac{3}{4}$ - 10 x 8	4
5	78-322	Brush	1
6	HB-14-20-075	Hex Bolt, $\frac{1}{4}$ - 20 x $\frac{3}{4}$	5
	HNFL-14-20	Flange Whiz-loc Nut, $\frac{1}{4}$ - 20	5
7	78-344	Brush Holder	1
8	72-134	Castor Fork	4
9	72-053	Quick Spacer $\frac{1}{2}$ "	20
10	18-223	Flange Bushing (part of 72-139)	8
11	HG-14-28-180	Grease Fitting, $\frac{1}{4}$ - 28 x 180° (part of 72-139)	2
12	72-136	Quick Spacer, 10GA	12
13	42-539	Lynch Pin, $\frac{5}{16}$	4
14	72-023	Flange Bearing	2
	HG-14-28-180	Grease Fitting, $\frac{1}{4}$ - 28 x 180° (part of 72-023)	2
15	HNFL-38-16	Flange Whiz-loc Nut, $\frac{3}{8}$ - 16	8
	HB-38-16-125	Hex Bolt, $\frac{3}{8}$ - 16 x $1\frac{1}{4}$	8
16	72-139	Single Castor Wheel Arm	2
17	HB-38-16-275	Hex Bolt, $\frac{3}{8}$ - 16 x $2\frac{3}{4}$	6
	HW-38	Flat Washer, $\frac{3}{8}$	6
	HNFL-38-16	Flange Whiz-loc Nut, $\frac{3}{8}$ - 16	6
18	HHP-.177	Bridge Pin, .177 x 3.75	4
19	72-103	Reel Lift Rod	2
20	HCP-100-250	Clevis Pin, 1 x 2	4
21	72-133	Single Reel Housing	1
	8803-114	Trim Black with Lace, 114"	1
22	72-144	Single Reel Lift Chain	2
23	18-362	Straight Thread Reducer	1
24†	72-199	Hydraulic Motor	1
25	72-075	Hydraulic Hose, 48"	1
26	72-043	$\frac{1}{2}$ " Male Quick Coupler	2
27	72-097	Motor Mount	1
	HB-38-16-100	Hex Bolt, $\frac{3}{8}$ - 16 x 1	4
	HW-38	Flat Washer, $\frac{3}{8}$	4
	HNFL-38-16	Flange Whiz-loc Nut, $\frac{3}{8}$ - 16	4
28	HB-38-16-150	Hex Bolt, $\frac{3}{8}$ - 16 x $1\frac{1}{2}$	2
	HW-38	Flat Washer, $\frac{3}{8}$	2
	HNTL-38-16	Nylon Lock Nut, $\frac{3}{8}$ - 16	2
29	78-428	Hub	1
	HSSHS-38-16-063	Set Screw, $\frac{3}{8}$ - 16 x $\frac{5}{8}$ (part of 78-237)	2

(Continued on next page)

†	72-199-01	Seal kit	1 per
	HWK-316-063	Woodruff Key, $\frac{3}{16}$ x $\frac{5}{8}$	1 per

No other parts are replaceable for hydraulic motors.

72-002 RUBBER FINGER SWEEPER HEAD DRAWING

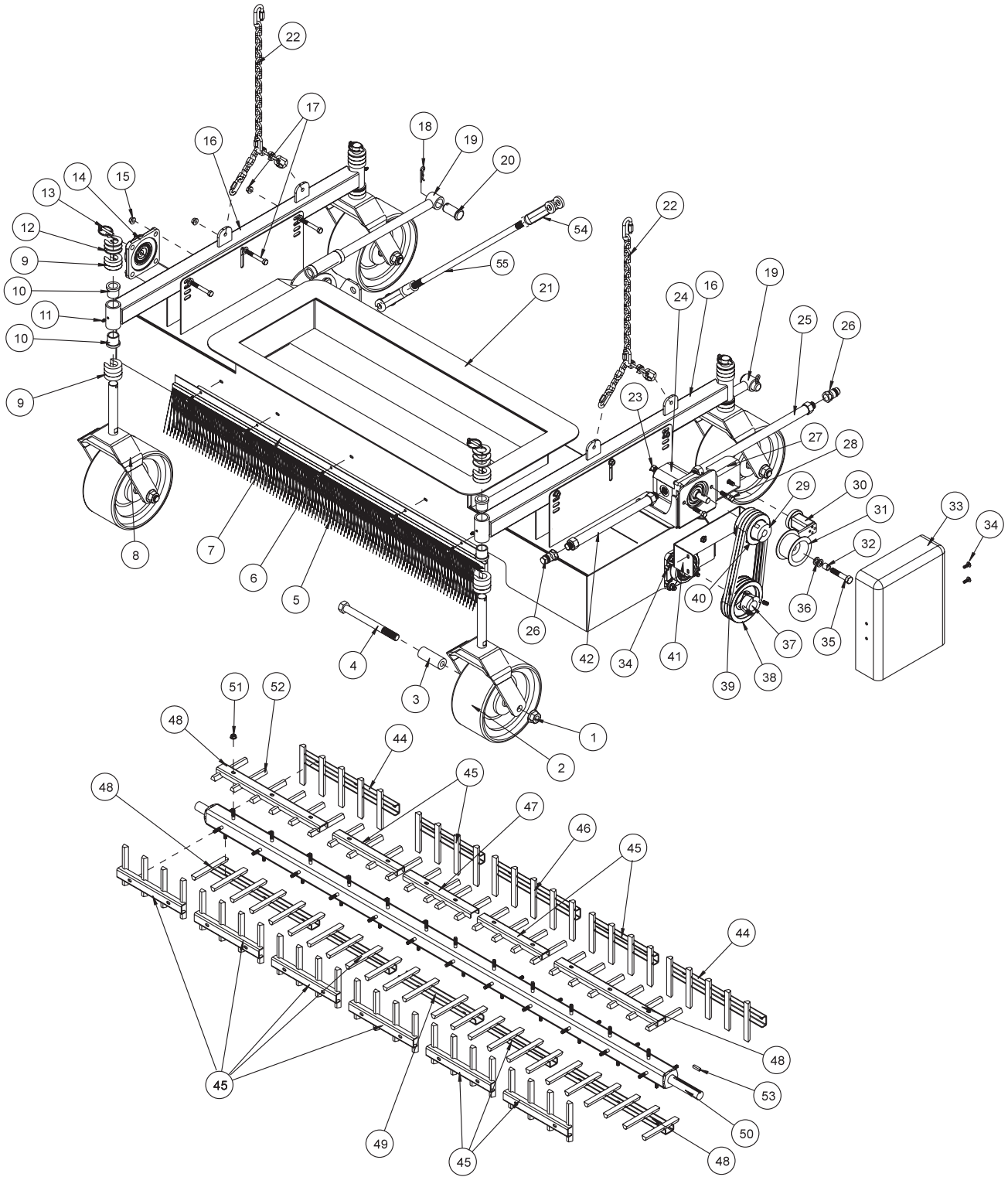

Accessories

72-002 RUBBER FINGER SWEEPER HEAD PARTS LIST

REF#	PART#	DESCRIPTION	QUANTITY
30	78-224	Belt Tensioner	1
	HBM-10-1.50-30	Metric Hex Bolt, 10 - 1.50 x 30 (part of 78-224)	1
	HWLM-10	Metric Lock Washer, 10 (part of 78-224)	1
31	16-013	Idler pulley	1
32	76-275	Spacer (part of 78-224)	1
33	72-056	Belt Guard	1
34	HSTP-14-20-075	Phillip Head Machine Screw, 1/4 - 20 x 3/4	4
	78-274	Cage Nut	4
35	HB-12-13-250	Hex Bolt, 1/2 - 13 x 2 1/2 (part of 78-224)	1
	HNCL-12-13	Center Nylon Lock Nut, 1/2 - 13 (part of 78-224)	1
36	HMB-12-14	Machine Bushing, 1/2 x 14GA	2
37	78-431	Hub, 1 1/4	1
	HSSHS-38-16-063	Set Screw, 3/8 - 16 x 5/8 (part of 72-035)	2
38	78-425	Pulley	1
39	72-038	Belt	3
40	78-424	Pulley	1
41	72-058	Belt Guard Mount	1
	HB-516-18-075	Hex Bolt, 5/16 - 18 x 3/4	2
	HW-516	Flat Washer, 5/16	2
	HNFL-516-18	Flange Whiz-loc Nut, 5/16 - 18	2
42	72-074	Hydraulic Hose, 39"	1
44	72-091	Finger Clamp, 14 3/4"	2
45	78-297	Finger Clamp, 10"	12
46	78-287	Finger Clamp, 13"	1
47	78-327	Finger Clamp, 10 1/2"	1
48	72-092	Finger Clamp, 16"	4
49	78-326	Finger Clamp, 12"	1
50	72-125	Finger Reel	1
51	HNFL-516-18	Flange Whiz-loc Nut, 5/16 - 18	48
52	8969-5.250	Sweeper Finger	96
53	HKSQ-14-100	Square Key, 1/4 x 1/4 x 1	1
54	42-040	Yoke End	2
	HNJ-34-16	Jam Nut, 3/4 - 16	2
	HCP-34-200	Clevis Pin, 3/4 x 2	2
	HHP-18	Bridge Pin, 1/8	2
55	72-148	Sway Bar	1

VERTICUT REEL VALVE HANDLE

⚠ WARNING

If the rubber finger sweeper head is installed on your unit and verticut reel handle is activated, the hydraulic system may be damaged due to overheating the oil. Remove the verticut reel valve handle when using the rubber finger sweeper head (72-002).

72-005 BRUSH REEL SWEEPER HEAD DRAWING

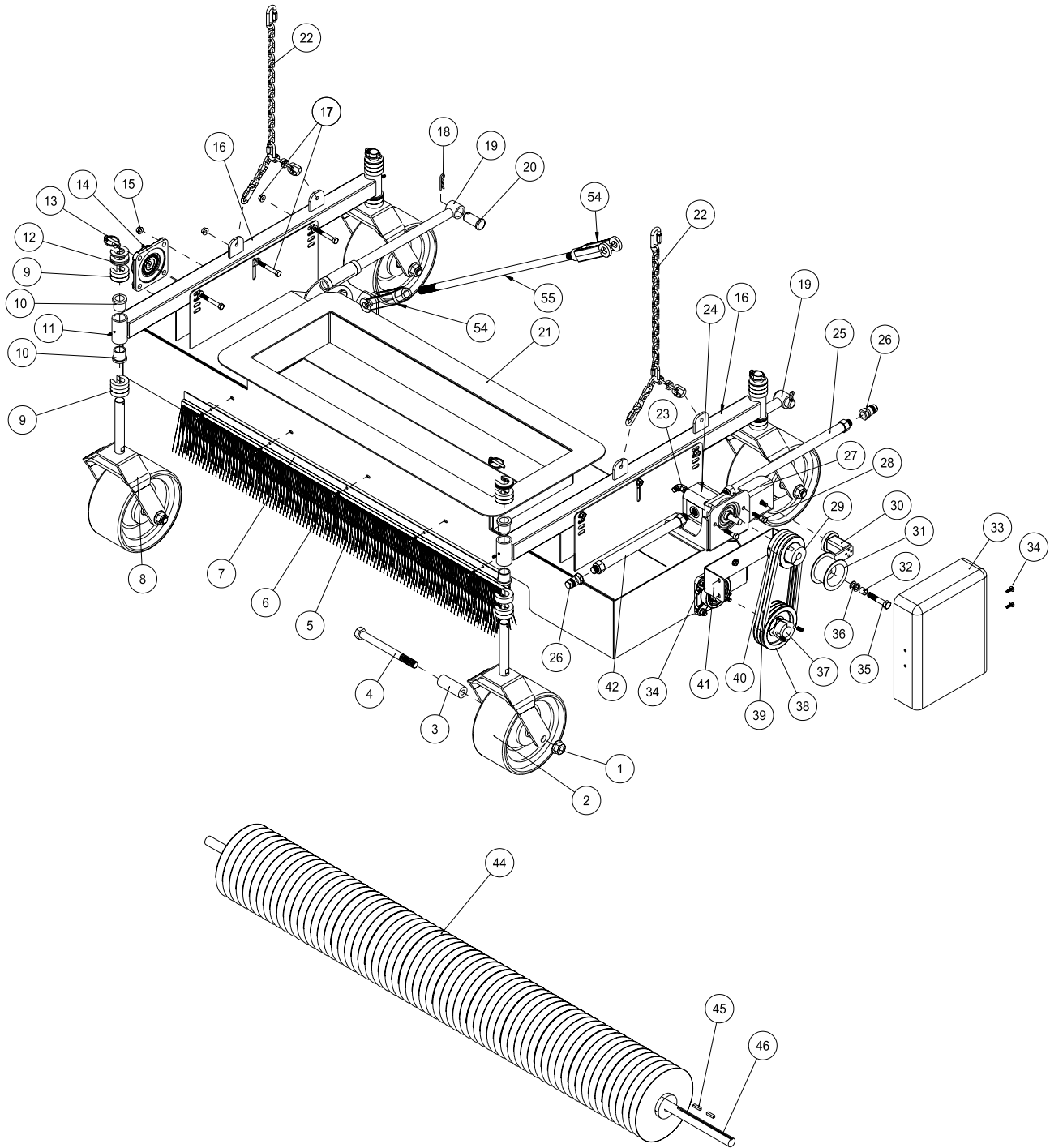

Accessories

72-005 BRUSH REEL SWEEPER HEAD PARTS LIST

REF#	PART#	DESCRIPTION	QUANTITY
1	HNTL-34-10	Nylon Lock Nut, $\frac{3}{4}$ - 10	4
2	78-012	Tire and Wheel	4
	78-012-01	Bearing (part of 78-012)	2 per Wheel
3	72-135	Castor Wheel Spacer	8
4	HB-34-10-800	Hex Bolt, $\frac{3}{4}$ - 10 x 8	4
5	78-322	Brush	1
6	HB-14-20-075	Hex Bolt, $\frac{1}{4}$ - 20 x $\frac{3}{4}$	5
	HNFL-14-20	Flange Whiz-loc Nut, $\frac{1}{4}$ - 20	5
7	78-344	Brush Holder	1
8	72-134	Castor Fork	4
9	72-053	Quick Spacer, $\frac{1}{2}$ "	20
10	18-223	Flange Bushing (part of 72-139)	8
11	HG-14-28-180	Grease Fitting, $\frac{1}{4}$ - 28 x 180° (part of 72-139)	2
12	72-136	Quick Spacer 10GA	12
13	42-539	Lynch Pin, $\frac{5}{16}$	4
14	72-023	Flange Bearing	2
	HG-14-28-180	Grease Fitting, $\frac{1}{4}$ - 28 x 180° (part of 72-023)	2
15	HNFL-38-16	Flange Whiz-loc Nut, $\frac{3}{8}$ - 16	8
	HB-38-16-125	Hex Bolt, $\frac{3}{8}$ - 16 x $1\frac{1}{4}$	8
16	72-139	Single Castor Wheel Arm	2
17	HB-38-16-275	Hex Bolt, $\frac{3}{8}$ - 16 x $2\frac{3}{4}$	6
	HW-38	Washer $\frac{3}{8}$	6
	HNFL-38-16	Flange Whiz-loc Nut, $\frac{3}{8}$ - 16	6
18	HHP-.177	Bridge Pin, .177 x 3.75	4
19	72-103	Reel Lift Rod	2
20	HCP-100-250	Clevis Pin, 1 x $2\frac{1}{2}$	4
21	72-133	Single Reel Housing	1
	8803-114	Trim Black with Lace, 114"	1
23	18-362	Straight Thread Reducer	1
24†	72-199	Hydraulic Motor	1
25	72-075	Hydraulic Hose, 48"	1
26	72-043	$\frac{1}{2}$ " Male Quick Coupler	2
27	72-097	Motor Mount	1
	HB-38-16-100	Hex Bolt, $\frac{3}{8}$ - 16 x 1	4
	HW-38	Flat Washer, $\frac{3}{8}$	4
	HNFL-38-16	Flange Whiz-loc Nut, $\frac{3}{8}$ - 16	4
28	HB-38-16-125	Hex Bolt, $\frac{3}{8}$ - 16 x $1\frac{1}{4}$	2
	HW-38	Flat Washer, $\frac{3}{8}$	2
	HNTL-38-16	Nylon Lock Nut, $\frac{3}{8}$ - 16	2
29	78-428	Hub	1
	HSSHS-38-16-063	Set Screw, $\frac{3}{8}$ - 16 x $\frac{5}{8}$ (part of 78-237)	2

(Continued on next page)

†	72-199-01	Seal kit	1 per
	HWK-316-063	Woodruff Key, $\frac{3}{16}$ x $\frac{5}{8}$	1 per

No other parts are replaceable for hydraulic motors.

72-005 BRUSH REEL SWEEPER HEAD DRAWING

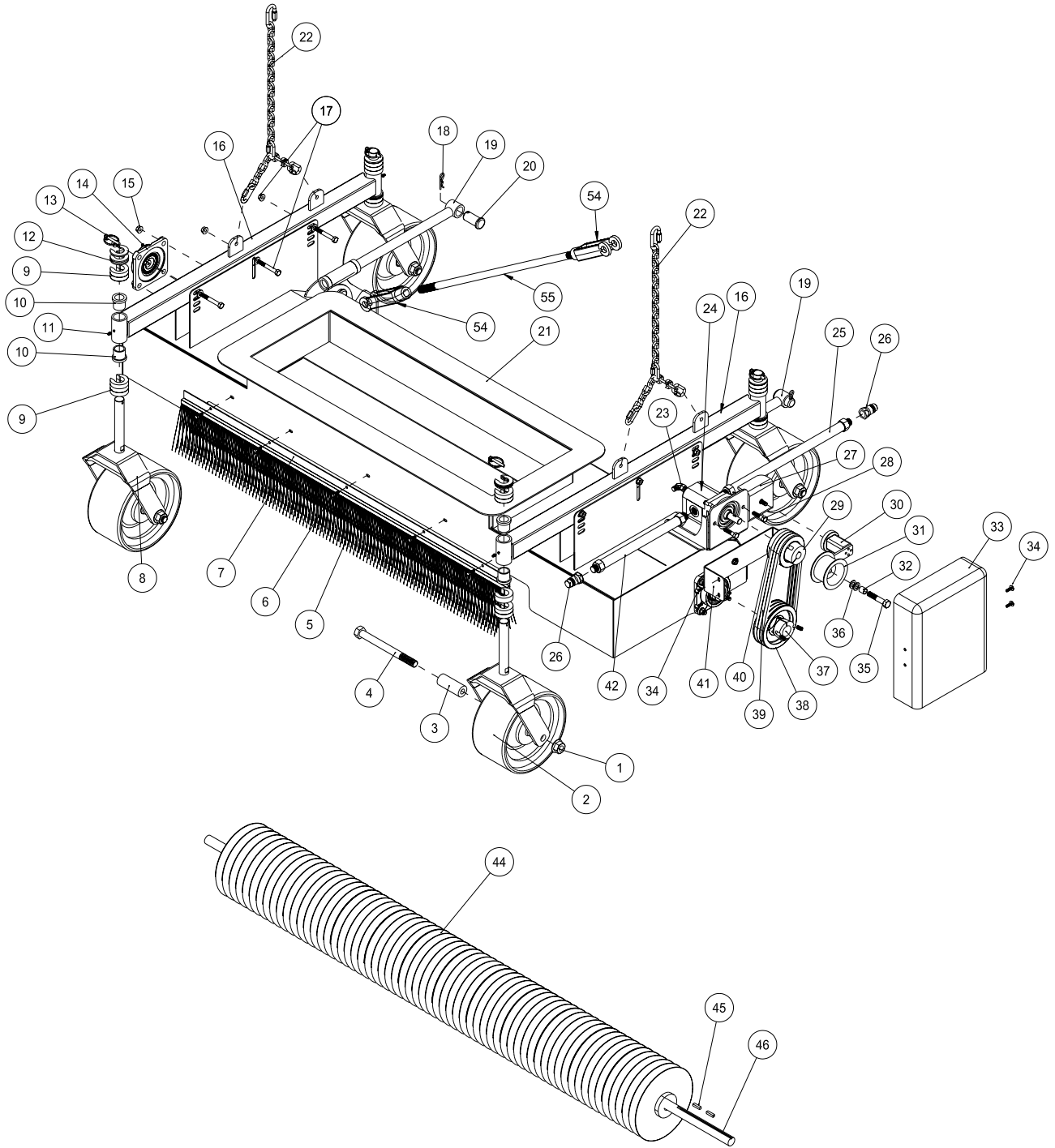

Accessories

72-005 BRUSH REEL SWEEPER HEAD PARTS LIST

REF#	PART#	DESCRIPTION	QUANTITY
30	78-224	Belt Tensioner	1
	HBM-10-1.50-30	Metric Hex Bolt, 10 - 1.50 x 30 (part of 78-224)	1
	HWLM-10	Metric Lock Washer, 10 (part of 78-224)	1
31	16-013	Idler pulley	1
32	76-275	Spacer (part of 78-224)	1
33	72-056	Belt Guard	1
34	HSTP-14-20-075	Phillip Head Machine Screw $\frac{1}{4}$ - 20 x $\frac{3}{4}$	4
	78-274	Cage Nut	4
35	HB-12-13-250	Hex Bolt, $\frac{1}{2}$ - 13 x $2\frac{1}{2}$ (part of 78-224)	1
	HNCL-12-13	Center Nylon Lock Nut, $\frac{1}{2}$ - 13 (part of 78-224)	1
36	HMB-12-14	Machine Bushing, $\frac{1}{2}$ x 14GA	2
37	78-431	Hub, $1\frac{1}{4}$	1
	HSSHS-38-16-063	Set Screw, $\frac{3}{8}$ - 16 x $\frac{5}{8}$ (part of 72-035)	2
38	78-425	Pulley	1
39	72-038	Belt	3
40	78-424	Pulley	1
41	72-058	Belt Guard Mount	1
	HB-516-18-075	Hex Bolt, $\frac{5}{16}$ - 18 x $\frac{3}{4}$	2
	HW-516	Flat Washer, $\frac{5}{16}$	2
	HNFL-516-18	Flange Whiz-loc Nut, $\frac{5}{16}$ - 18	2
42	72-074	Hydraulic Hose 39"	1
44*	72-188	Spiral Brush	1
45*	HKSQ-14-100	Square Key, $\frac{1}{4}$ x $\frac{1}{4}$ x 1	2.
46*	72-125-01	Shaft	1
47	72-144	Single Reel Lift Chain	2
48	72-148	Sway Bar	1
49	42-040	Yoke End	2
	HNJ-34-16	Jam Nut, $\frac{3}{4}$ - 16	2
	HCP-34-200	Clevis Pin, $\frac{3}{4}$ x 2	2
	HHP-18	Bridge Pin, $\frac{1}{8}$	2
*	72-006	Brush Head Only (includes * items)	

72-003 HAND HELD VACUUM HOSE DRAWING

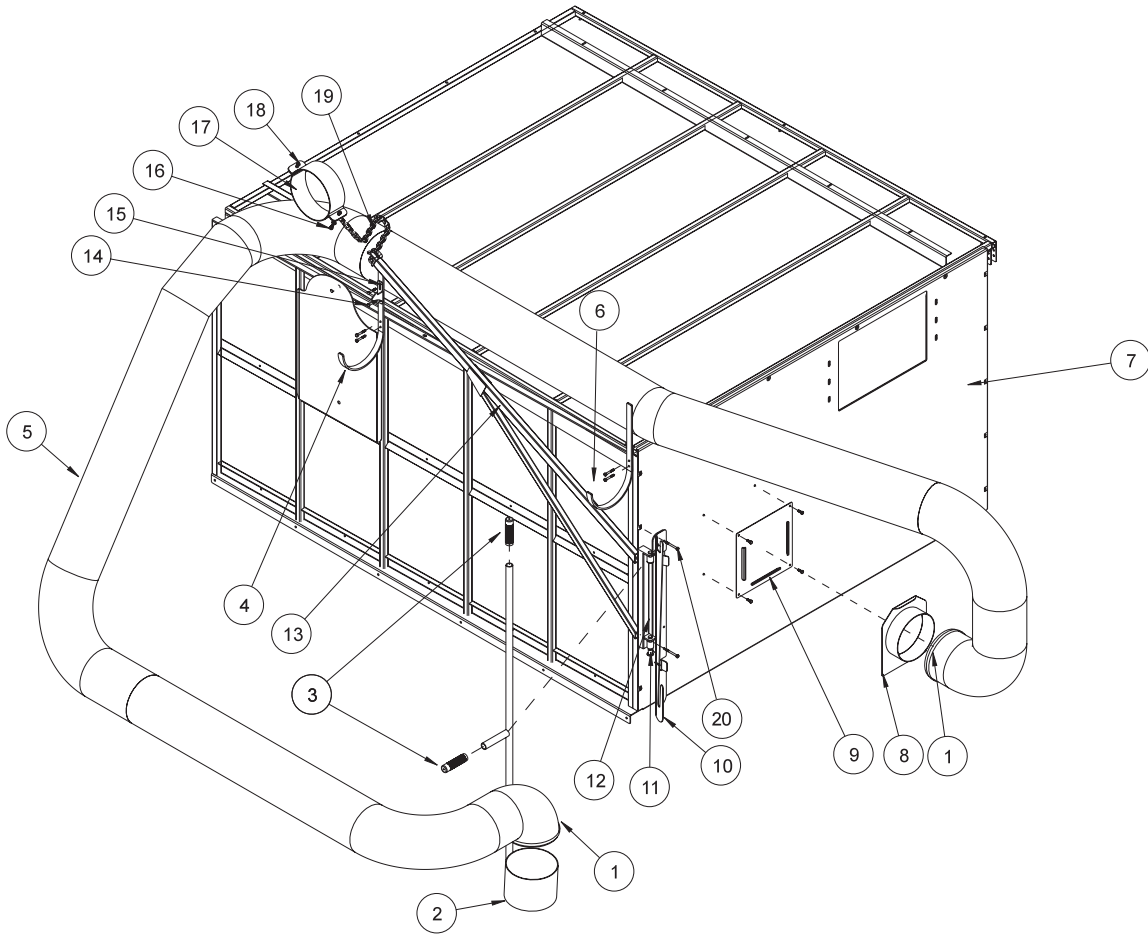

FRONT VIEW HOLE LOCATION

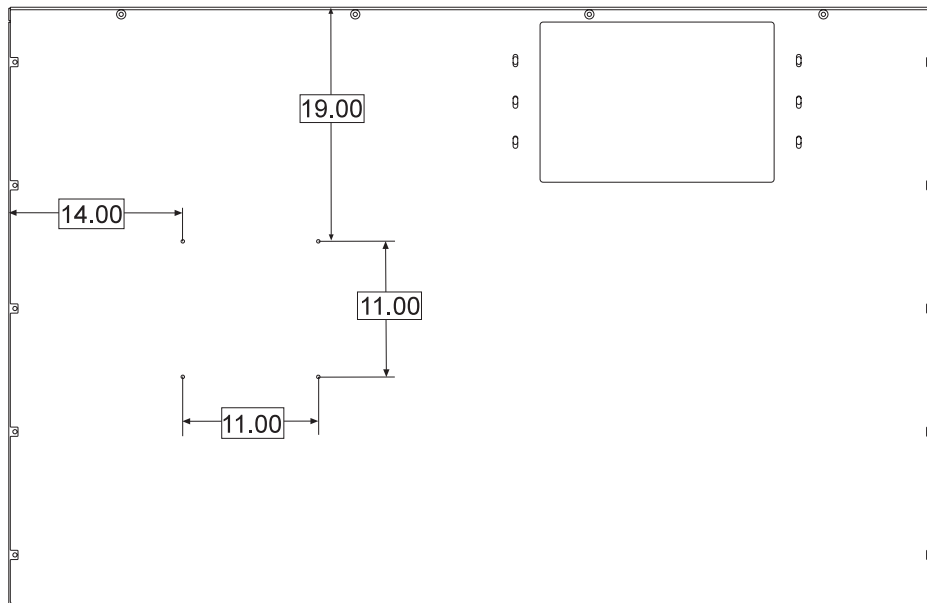

72-003 HAND HELD VACUUM HOSE PARTS LIST

REF#	PART#	DESCRIPTION	QUANTITY
1	18-340	Hose Clamp	2
2	78-354	Hose Handle	1
3	15-019	Round Grip	2
4	72-142	Hose Hanger	2
	HB-14-20-175	Hex Bolt, 1/4 - 20 x 1 3/4	4
	HNFL-14-20	Flange Whiz-loc Nut 1/4 - 20	4
5	8970-300	Vacuum Hose	1
6		Hopper Right Side	
7		Hopper Front	
8	78-314	Remote Hose Connection	1
9	72-141	Hose Plate	1
	HB-14-20-075	Hex Bolt, 1/4 - 20 x 3/4	4
	HNFL-14-20	Flange Whiz-loc Nut, 1/4 - 20	4
10	78-350	Handle Holder	1
	8803-17	Trim, Black	1
11	18-043	Flange Bushing (part of 72-153)	2
12	72-153	Boom Mounting Bracket	1
	HP-18-100	Cotter Pin, 1/8 x 1	2
13	72-155	Vacuum Hose Boom	1
14	HSTP-14-20-075	Machine Screw, 1/4 - 20 x 3/4	2
	HNFL-14-20	Flange Whiz-loc Nut, 1/4 - 20	2
15	72-152	Latch Bracket	1
16	HB-516-18-075	Hex Bolt, 5/16 - 18 x 3/4	1
	HW-516	Flat Washer, 5/16	1
	HNFL-516-18	Flange Whiz-loc Nut, 5/16 - 18	1
17	72-154	Hose Clamp	2
18	HB-516-18-075	Hex Bolt, 5/16 - 18 x 3/4	1
	HNFL-516-18	Flange Whiz-loc Nut, 5/16 - 18	1
19	8820-25	Straight Link Chain, 25"	1.
20	HB-14-20-275	Hex Bolt, 1/4 - 20 x 2 3/4	2
	HNFL-14-20	Flange Whiz-loc Nut, 1/4 - 20	2

(Continued on next page)

INSTALLATION INSTRUCTIONS

You will need two people and the tailgate open with an empty hopper **and the machine not operating.**

1. Drill (4) $\frac{9}{32}$ holes in front panel (Ref 7) to the left side, see drawing. Start with the top left hole at 19 inches down from the top and 14 inches in from the left.
2. Proceed to drill the three remaining holes in a square pattern at 11 inches apart center to center. De-burr holes and mount the hose plate (Ref 9) and secure with four (4) $\frac{1}{4}$ -20 x $\frac{3}{4}$ Hex Bolts and Flange Whiz-loc Nuts.
3. Next mount the handle holder (Ref 10) facing the front panel, at the left are a vertical row of Hex Bolts. Remove the second and fourth Hex Bolts. Cut 5 inches off of the trim and put it into the top U shaped slot of handle holder. Put the remaining piece into the bottom slot. Install boom mount bracket (Ref 12) between hopper and handle holder. Use $\frac{1}{4}$ -20 x $2\frac{3}{4}$ Hex Bolts and Flange Whiz-loc Nuts (Ref 20). Pull boom mount bracket outward in the slots and tighten Hex Bolts.
4. Mount the hose hanger (Ref 4) on the right hand side (Ref 6), in the upper right hand corner. Remove and save the two Hex Bolts and nuts that are already in the upper right hand corner. Mount one hose hanger here using the Hex Bolts and nut you just removed.
5. To mount the second hose hanger, remove the drill screw in the front upright near the plate for the door arms is welded. Using the screw hole, drill a $\frac{9}{32}$ hole completely through to the inside and de-burr. Mount the hanger with one $\frac{1}{4}$ - 20 x $1\frac{3}{4}$ Hex Bolt and Flange Whiz-loc Nut in the lower hole of the hanger. With the hanger in the vertical position, use the remaining hole as a guide to drill a second mounting hole through to the inside. De-burr and install the remaining Hex Bolt and nut.
6. Install latch bracket (Ref 15) using two $\frac{1}{4}$ - 20 x $\frac{3}{4}$ machine screws and Flange Whiz-loc Nuts (Ref 14).
7. Next install boom (Ref 13) onto boom mount bracket. Hold in place with two $\frac{1}{8}$ x 1 cotter pins (Ref 11). To adjust, swing boom back alongside the hopper until support comes in contact with the latch bracket. Slide latch bracket upward in the slot holes until it lifts boom $\frac{1}{8}$ ". Tighten the Hex Bolts (Ref 14).
8. Next connect the hose to the hose handle (Ref 2) with hose on the same side as the long handle and secure with one hose clamp (Ref 1). At the other end of the hose connect the remote hose connector and secure with the other hose clamp.
9. Hex Bolt hose clamps (Ref 17) together over the 8" Hose, close to center. Use the $\frac{5}{16}$ - 18 x $\frac{3}{4}$ Hex Bolt and Flange Whiz-loc Nut (Ref 18) on one side. Use the $\frac{5}{16}$ - 18 x $\frac{3}{4}$ Hex Bolt, washer and Flange Whiz-loc Nut (Ref 16) on the other end with the washer between the Hex Bolt and the chain. The Hex Bolt must go through the end link in the chain first then through the clamp.
10. Put the two round grips (Ref 3) on to the hose handle.
11. For storage place remote hose connector in hose plate (Ref 9) on the front panel. Drape hose over the top and go toward the back of machine. Just past the rear hose hanger bring hose to the side of machine and up into the hose hangers. At the front place the hose handle (Ref 2) into the handle holder (Ref 10).
12. To use the remote vacuum remove the cover plate from either side of the vacuum housing and place the remote hose connector (Ref 8) there. Place the cover plate into the hose plate (Ref 9). Before using the vacuum the lever on the left side of the vacuum housing must be pulled out and turned clockwise 90° and pushed in.
13. You may want to remove the hose handle, hose and remote hose connector if you are not going to use the remote vacuum for an extended amount of time.

DECAL LIST

REF#	PART#	DESCRIPTION	QUANTITY
A	25-279	Decal, Safety Warning	3
B	25-286	Decal, Pinch Point	2
C	25-355	Decal, Tire Pressure 18 PSI	2
D	25-356	Decal, Tire Pressure 20 PSI	2
E	25-374	Decal, Smithco 12"	2
F		Decal, Serial Tag	1
G	25-363	Decal, Max. Depth	2
	72-182	Decal, Max Load	2
H	27-093	Decal, Hydraulic Oil	1
I	72-047	Decal, Big Vac (Large)	1
J	72-054	Decal, Control Panel	1
K	72-061	Decal, Big Vac (Small)	2
L	72-087	Decal, Tractor PTO	1
M	72-088	Decal, Danger Guard Missing	2
N	72-089	Decal, Hose Routing	1
O	75-651	Decal, Hopper Lift Safety	1
P	76-305	Decal, Rotating Parts	2
Q	76-307	Decal, Tower Warning	2
R	72-016	Decal, Hang Tag Dumping	1
S	78-552	Decal, Open/Close	1

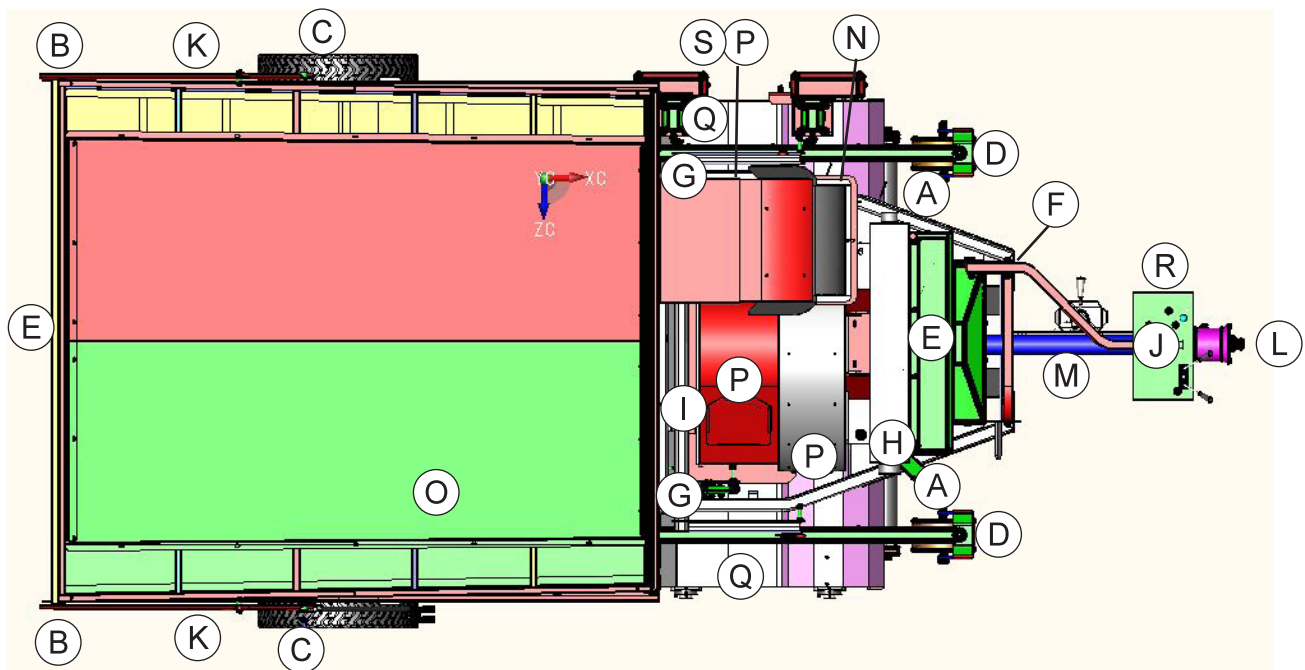

Reference

QUICK REFERENCE REPLACEMENT PARTS

REPLACEMENT FILTER

60-334 Hydraulic Oil Filter Element

REPLACEMENT BELTS

72-036 Belt 5V x 540 (2 for pump 5 for blower)

72-037 Belt 3V x 400 (thatcher reel) 3

72-038 Belt 3V x 315 (finger reel) 3

SEAL KITS

72-151 Hydraulic Valve (no seal kit see drawing)\

78-416 Hydraulic Valve 3 Bank

10-187 Hydraulic Cylinder

14-273 Seal Kit

72-040 Hydraulic Cylinder

72-040-01 Seal Kit

72-040-02 Pin with Clips (2 per cylinder)

*72-187 Hydraulic Motor (thatcher reel)

*72-199 Hydraulic Motor (finger reel)

72-199-01 Seal Kit

*72-185 Hydraulic Double Pump

78-413-01 Front Seal Kit

72-185-01 Rear Seal Kit

72-077 Hearing Protection

* NO OTHER PARTS ARE REPLACEABLE FOR HYDRAULIC MOTOR OR PUMP

HYDRAULIC FLUID

SAE 10W-40 API Service SJ or higher motor oil

The Smithco Commercial Products Two-Year Limited Warranty

The Smithco Commercial Products Two-Year Limited Warranty

Smithco, Inc. (Smithco) warrants your 2016 or newer Smithco Commercial Product ("Product") purchased after October 1, 2016 to be free from defects in materials or workmanship for the period of time listed below. Where a warrantable condition exists, Smithco will repair the Product at no cost to you including diagnosis, labor (at the Smithco standard labor rate, subject to the Smithco flat rate schedule), and parts.

Warranty Duration is:

- (1) Two years, 1500 operational hours* from the date of delivery to the original purchaser or Five years from the date of original manufacturer of the product, whichever occurs first. (*Products equipped with hour meter).
- (2) Products used in rental situations are covered for 90 days from date of delivery to original user/renter.

Owner Responsibilities:

As the Product owner, you are responsible for required maintenance and adjustments stated in your Owner's Manual. Failure to perform required maintenance and adjustments can be grounds for disallowing a warranty claim. **You are particularly responsible to train all present and future operators of this product on the safe operation of this product at your location.**

Instructions for Obtaining Warranty Service:

You are responsible for notifying the Authorized Smithco Products Distributor from whom you purchased the Product as soon as you believe a warrantable condition exists and not later than 30 days from discovery of the condition.

If you need help locating an Authorized Smithco Distributor, or if you have questions regarding your warranty rights or responsibilities, you may contact us at:

Smithco Product Support Department
200 West Poplar Ave.
Cameron, Wisconsin 54822
Telephone: 800-891-9435 E-Mail: ProductSupport@Smithco.com

Maintenance Parts:

Parts scheduled for replacement as required maintenance ("Maintenance Parts"), are warranted for the period of time up to the scheduled replacement time for that part.

Items/Conditions Not Covered:

 Not all product failures or malfunctions that occur during the warranty period are defects in materials or workmanship. The items/conditions listed below are not covered by this warranty:

 Product failures which result from the use of non-Smithco replacement parts, or from installation and use of add-on, modified, or unapproved accessories are not covered.

 Product failures which result from failure to perform required maintenance and/or adjustments are not covered.

 Product failures that result from operating the Product in an abusive, negligent or reckless manner are not covered.



This warranty does not apply to parts subject to consumption through use, unless found to be defective. Examples of parts which are consumed, or used up, during normal Product operation include, but are not limited to: blades, tines, teeth, scarifiers, rakes, plates, wear plates, castor wheels, tires, batteries, filters, belts, nozzles, etc.



This warranty does not apply to failures caused by outside influence. Items considered to be outside influence include, but are not limited to, weather, storage practices, contamination, use of unapproved coolants, lubricants, additives, or chemicals, etc.



This warranty does not apply to normal "wear and tear" items. Normal "Wear and Tear" includes, but is not limited to, damage to seats due to wear or abrasion, worn painted surfaces, scratched decals or windows, etc.



Smithco may require the return of failed parts or components in order to determine the validity of any warranty claim.



Smithco will not be obligated to replace components of other manufacturers if inspection by the original component manufacturer indicates that failure was due to normal wear and tear, expected consumption through use or improper care or service.

Other Legal Disclaimers:

The above remedy for product defects through repair or replacement by an authorized Smithco distributor or dealer is the purchaser's sole remedy for any defect. This warranty gives you specific legal rights, and you may also have other rights which vary from state to state.

THERE ARE NO OTHER EXPRESS WARRANTIES OTHER THAN THOSE SET FORTH ABOVE. ALL IMPLIED WARRANTIES OF MERCHANTABILITY AND FITNESS FOR USE ARE LIMITED TO THE DURATION OF THE LIMITED WARRANTIES CONTAINED HEREIN.

Some states may not allow limitations on how long an implied warranty lasts, so the above limitation may not apply to you.

THE SMITHCO COMPANY IS NOT LIABLE FOR INDIRECT, INCIDENTAL OR CONSEQUENTIAL DAMAGES IN CONNECTION WITH THE USE OF THE PRODUCT, INCLUDING ANY COST OR EXPENSE OF PROVIDING A SUBSTITUTE PRODUCT OR SERVICE DURING PERIODS OF MALFUNCTION OR NON-USE.

Some states may not allow the exclusion of indirect, incidental or consequential damages, so the above exclusion may not apply to you.

