



*AFC Sport Truck*  
*52-000*  
*SN: AFT1001*

*January 2009*  
*Revised September 2009*

# CONTENTS

Introduction

## **Introduction ..... 1-8**

Introduction .....	1
Symbols .....	2-3
Safe Practices .....	4
Specification .....	5
Optional Equipment .....	6
Operation .....	7
Controls and Instruments .....	8

Service

## **Service ..... 9-14**

Maintenance .....	9-11
Service Chart .....	12
End User's Service Chart .....	13
Hitch Adjustments .....	14
Storage .....	14

Diagrams

## **Diagrams ..... 16-19**

Hydraulic Diagram .....	16-17
Wiring Diagram .....	18-19

Parts

## **Parts ..... 20-47**

Main Machine .....	20-21
Nose Cone .....	22-23
Linkage and Brakes .....	24-25
Front Axle .....	26-27
Seat Panel .....	28-31
Engine and Exhaust .....	32-35
Power Unit .....	36-37
Hitch and Box .....	38-39
13-729 2-Bank Valve .....	40-41
15-301 Orbitrol .....	42-43
15-315 Hydraulic Pump .....	44-45
Brake Assembly .....	46-47

Accessories

## **Accessories ..... 48-61**

52-005 60" Manual Plow52-005 .....	48-49
52-006 Spring Tine Cultivator w/ Castors .....	50-51
52-007 Dust Suppression .....	52-53
52-008 Rear Drag .....	54-55
52-010 Staight Steel Blade Scarifier .....	56-57
52-012 Flex Action Field Fnisher .....	58-59
43-009 Coco Mat Finisher .....	60-61

Reference

## **Reference ..... 63-64**

Decal List.....	63
Quick Reference Replacement Parts .....	64
2 Year Limited Warranty .....	

Thank you for purchasing a **Smithco** product.

Read this manual and all other manuals pertaining to this Sport Truck carefully as they have safety, operating, assembly and maintenance instructions. Failure to do so could result in personal injury or equipment damage.

Keep manuals in a safe place after operator and maintenance personnel have read them. Right and left sides are from the operator's seat, facing forward.

All **Smithco** machines have a Serial Number and Model Number. Both numbers are needed when ordering parts. The serial number plate on the Sport Truck is located on the right front main frame. Refer to engine manual for placement of engine serial number.

For easy access record your Serial and Model numbers here.

<b>SMITHCO</b> WAYNE, PENNSYLVANIA 19087 USA 610-688-4009 Fax 610-688-6069		DATE OF MFG. <input type="text"/>
SERIAL NO. <input type="text"/>	kW/hp <input type="text"/>	
MODEL NO. <input type="text"/>	kg/lb <input type="text"/>	

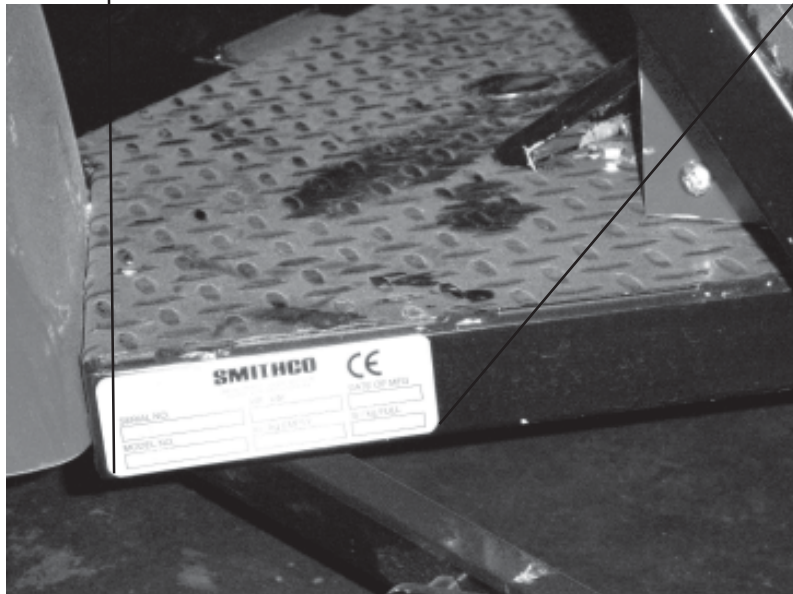

Information needed when ordering replacement parts:

1. Model Number of machine
2. Serial Number of machine
3. Name and Part Number of part
4. Quantity of parts

## SYMBOLS

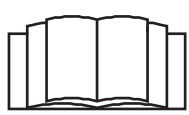

Read Operator's  
Manual



Electrical Power



No Electrical  
Power



Engine - Stop



Engine - Start



Engine - Run

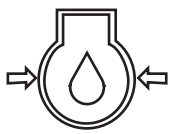

Engine Oil



Temperature  
Light

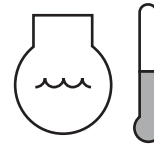

Water  
Temperature

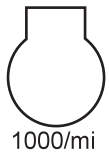

RPM

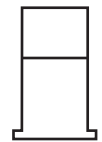

Gasoline



Diesel



Glow Plug - On



Glow Plug - Off



Glow Plug



Hour Meter

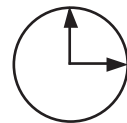

Hour Meter

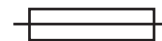

Fuse

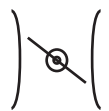

Hand Throttle



Choke - Closed



Choke - Open









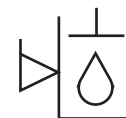



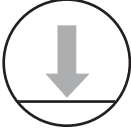

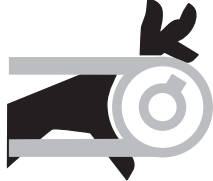
Park Brake

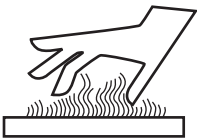
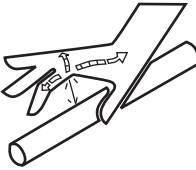
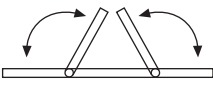
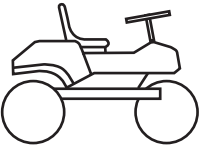
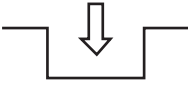
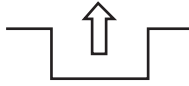

Park Brake  
Release

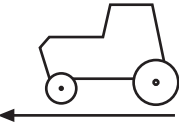

Hydraulic Oil  
Level

	Up/Down Arrow		Down/Lower		Up/Raise
	No Smoking		Moving Parts		Manual Operation
	Pinch Point		Step		Hot Surface
	Hydraulic Fluid Penetration		Lift Arm		Tractor
	Engage		Disengage		PTO
	Ground Speed		Fast		Slow
<b>H</b>	High	<b>L</b>	Low	<b>F</b>	Forward
<b>R</b>	Reverse	<b>N</b>	Neutral		Warning Danger Caution

## SAFE PRACTICES

1. It is your responsibility to read this manual and all publications associated with this machine (engine, accessories and attachments).
2. Never allow anyone to operate or service the machine or its attachments without proper training and instructions. Never allow minors to operate any equipment.
3. Learn the proper use of the machine, the location and purpose of all the controls and gauges before you operate the equipment. Working with unfamiliar equipment can lead to accidents.
4. Wear all the necessary protective clothing and personal safety devices to protect your head, eyes, ears, hands and feet. Operate the machine only in daylight or in good artificial light.
5. Beware of overhead obstructions and underground obstacles. Stay alert for hidden hazards.
6. Never operate equipment that is not in perfect working order or without decals, guards, shields, or other protective devices in place.
7. Never disconnect or bypass any switch.
8. Carbon monoxide in the exhaust fumes can be fatal when inhaled, never operate a machine without proper ventilation.
9. Fuel is highly flammable, handle with care.
10. Keep engine clean. Allow the engine to cool before storing and always remove the ignition key.
11. After engine has started, machine must not move. If movement is evident, the neutral mechanism is not adjusted correctly. Shut engine off and readjust so the machine does not move when in neutral position.
13. Never use your hands to search for oil leaks. Hydraulic fluid under pressure can penetrate the skin and cause serious injury.
14. This machine demands your attention. To prevent loss of control or tipping of the vehicle:
  - A. Use extra caution in backing up the vehicle. Ensure area is clear.
  - B. Do not stop or start suddenly on any slope.
  - C. Reduce speed on slopes and in sharp turns. Use caution when changing directions on slopes.
  - D. Stay alert for holes in the terrain and other hidden hazards.
15. Before leaving operator's position for any reason:
  - A. Disengage all drives.
  - B. Lower all attachments to the ground.
  - C. Set park brake.
  - D. Shut engine off and remove the ignition key.
16. Keep hands, feet and clothing away from moving parts. Wait for all movement to stop before you clean, adjust or service the machine.
17. Keep the area of operation clear of all bystanders.
18. Never carry passengers.
19. Stop engine before making repairs/adjustments or checking/adding oil to the crankcase.
20. Use parts and materials supplied by **Smithco** only. Do not modify any function or part.



## WEIGHTS AND DIMENSIONS

Length	97" ( 246cm)
Width	58" (147 cm)
Height	73" (185 cm)
Wheel Base	55" (140 cm)
Ground Clearance	6" ( 15 cm)
Capacity (with cargo box)	1200 lbs (544 kg) includes operator
Crated Weight	1350 lbs (612 kg)
Towing Capacity	1500lbs (680 kg)

## SOUND LEVEL (DBA) AT 3200 RPM

At ear level	82 dba
At 3 ft (0.914 m)	90 dba
At 30 ft (9.14 m)	81 dba

## ENGINE

Make	Briggs and Stratton vanguard
Model#	305447
Type/Spec#	0230 G1
Horsepower	16 Hp (12 Kw)
Fuel	Unleaded 87 Octane Gasoline Minimum
Cooling System	Air Cooled
Lubrication System	Full Pressure type
Alternator	16 AMP

## WHEELS & TIRE

(2) Front	W/20 x 10.00 x 10 Turf; 5 psi (.35 bar)
(2) Rear	22 x 11.00 x 10 Turf; 20 psi (1.4 bar)

## VEHICLE CONFIGURATION

Cab over single seat

## CONSTRUCTION

All steel, welded chassis, cargo box and frame, FRP body

## DRIVE AXLES

Spicer Dana automotive, 1200 pound capacity

## SPEED

Forward Speed	0-12 mph (0- 19 kph)
Reverse Speed	0-12mph (0-19 kph)

## STEERING

Hydraulic Power Steering

## BATTERY

Automotive type 45-12 volt

BCI Group	Size 45
Cold Cranking Amps	300
Ground Terminal Polarity	Negative (-)
Maximum Length	9" (23cm)
Maximum Width	5.38" (14cm)
Maximum Height	9" (23cm)

## SEAT

Adjustable position deluxe seat with back support

## FLUID CAPACITY

Crankcase Oil	3 pints ( 1.5 liters)
Fuel	32 pints ( 15 liters)
Hydraulic Fluid	8 pints ( 3.8 liters)
Grade of Fluid	SAE 10W-40 API Service SJ Motor Oil
80/90 Gear Lube	22 ounces (.65 liters)



## *OPTIONAL EQUIPMENT*

### **REAR MOUNTED GROOMING IMPLEMENTS**

26-007Q	Professional Infield Finisher
52-012	Flex Action Infield Finisher - Leveler
52-008	Rear Leveling/Finishing Implement w/Brush

### **CENTER MOUNTED SCARIFYING IMPLEMENTS**

52-006	Center mounted Spring tine Scarifier w/gage Wheels
52-010	Center Mounted Straight Blade Scarifier w/gage Wheels

### **FRONT MOUNTED IMPLEMENTS**

52-005	60" Front mounted (Manual Operation) Plow
--------	---

### **CHASIS MOUNTED OPTIONS & ACCESSORIES**

52-007	Dust Suppression System w/ baseball Base Rack
52-009	Spray Liner System
52-011	Dry Line Marker





## STARTING ENGINE

Before operating this machine, become familiar with all controls and functions of these units. Also complete all maintenance requirements and read all safety warnings. By knowing the machine thoroughly, how it operates and by doing the prescribed maintenance steps, you can expect relatively trouble-free operation for years to come.

1. Make sure the fuel flow valve, located on the fuel tank, is open.
2. Set park brake.
3. The ignition switch is located on the dashboard. Insert key (A) and turn clockwise until engine starts (C). Release key and it will return to run position (B). Use choke as necessary.
4. Allow engine to idle and warm up a few minutes before selecting a direction of travel.

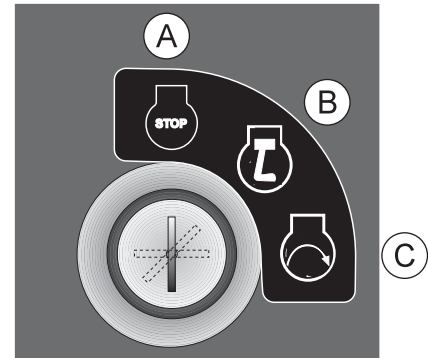

## PARKING BRAKE

The park brake is beside the drivers seat. This brake should be set at all times when the unit is not in operation. To set, push the handle forward. To release the park brake, pull the handle back. Major adjustments should be made by working with the yokes on each end of the brake cable.

## STEERING

It is important to familiarize yourself with the steering of the Sport Truck. The steering is power assisted by a pump located on the steering column. This feeds a hydraulic cylinder which steers the wheels. It will only go as far as the stop allows.

## HEADLIGHTS (OPTIONAL)

The Sport Truck is wired for 2 headlights to be mounted on the Roll bar.

## FOOT PEDALS

The accelerator pedal (D) is the furthest to the right. This pedal controls ground speed. Press pedal to increase engine RPM, varying the amount of movement of the pedal will vary the ground speed.

The brake (E) is the second pedal on the right. Operates the hydraulic brakes on rear wheels.

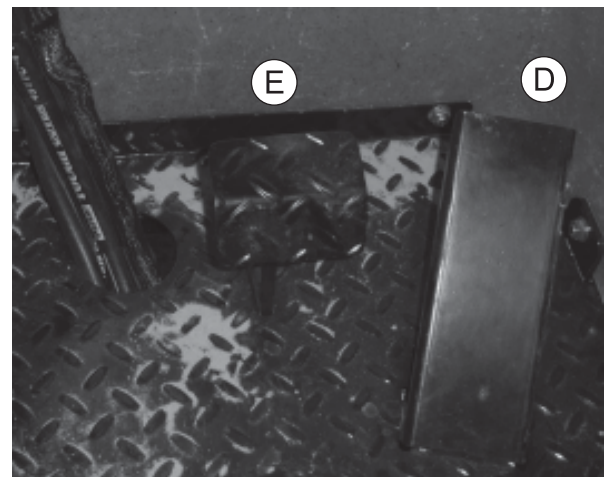

## CONTROLS AND INSTRUMENTS

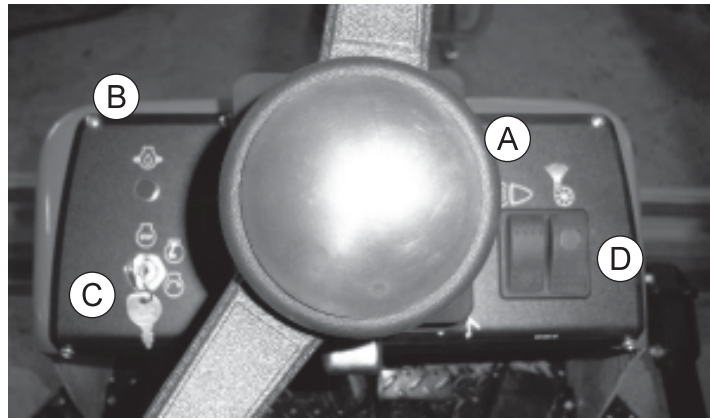
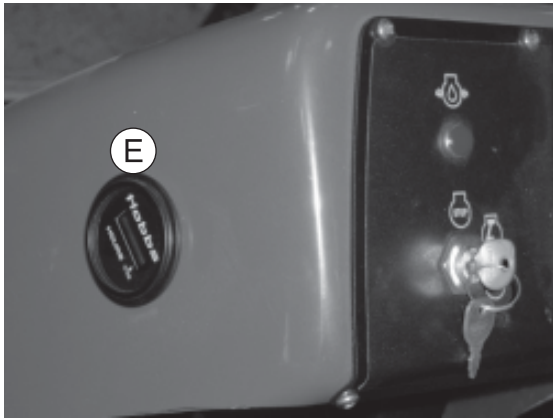

- A. **Light Switch** - This rocker switch will operate lights (optional)
- B. **Oil Light** - The oil light should come on when ignition is on without engine running. The oil light will light when the oil pressure is low. If oil light should come on, shut off engine immediately and find the cause.
- C. **Ignition Switch** - The ignition switch has three positions: Off - Run - Start.
- D. **Spray Pump** - This rocker switch turns the spray pump on by pushing on the top and turns it off by pushing on the bottom.
- E. **Hour Meter**- The hour meter indicates hours of machine operation. The hour meter operates when ignition switch is on.
- F. **Center Attachment Valve** - Lifts and Lowers the center attachments.
- G. **Rear Attachment Valve** - Lifts and lowers rear attachments.
- H. **Choke** - Close choke plate when starting a cold engine. A warm engine may not require "choking" to start.
- I. **Park Brake** - To set park brake, push the handle forward. To release the park brake, pull the handle back.
- J. **Shift Lever:** Gear selection F-N-R, with the shift pattern on the control panel. F = Forward, N = Neutral, R = Reverse.

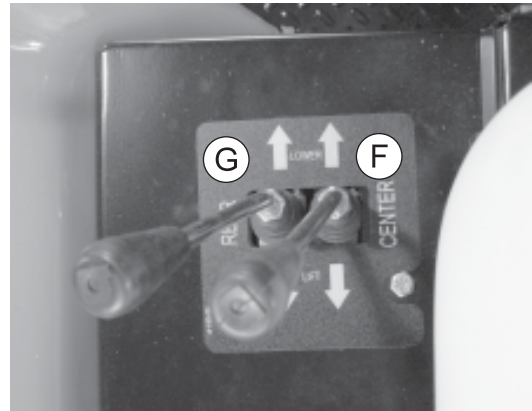



Before servicing or making adjustments to machine, stop engine and remove key from ignition.

Use all procedures and parts prescribed by the manufacturer's. Read the engine manual before operation.

The suggested maintenance checklist is not offered as a replacement for the manufacturer's but as a supplement. You must adhere to guidelines established by manufacturer for warranty coverage. In adverse conditions such as dirt, mud or extreme temperatures, maintenance should be more frequent.

### DAILY CHECKLIST

1. Check park brake adjustment. Adjust as required.
2. Check engine oil level. Add as needed. **DO NOT OVERFILL.**
3. Tire pressure should be: front 5 psi (.35 bar) and rear 20 psi (1.36 bar) maximum.
4. Inspect electrical system for loose connections or frayed wiring, including battery cables. Replace any faulty equipment or tighten if loose.
5. Check hardware for loose or missing nuts, bolts, screws, etc., and tighten or replace as needed.
6. Inspect hydraulic lines for damage or leaks. Never use hands to inspect leaks.
7. Check hydraulic oil level. The level should be 2" to 2 1/2" from top of fill neck when fluid is cold. If level is low, add SAE 10W-40 API Service SG motor oil.
8. Inspect steering, throttle and shift linkages for good hookups and clear travel.
9. Check controls for smooth, proper working operation. Lubricate as needed.

### LUBRICATION

Use No. 2 General purpose Lithium Base Grease and lubricate every 100 hours. The Sport Truck has seven grease fittings.

- A. One on the front cylinder
- B. One on each of the right and left front spindles
- C. One on the front axle.
- D. One on each of the right and left tie rod
- E. One on each center and rear cylinder

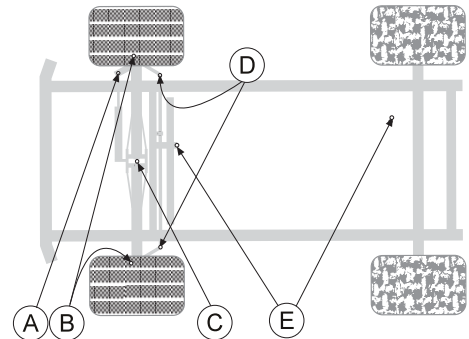

### AIR CLEANER ON ENGINE

1. Unhook clips on both sides of cover and remove cover.
2. Carefully slide pre-cleaner off cartridge.

To service pre-cleaner, wash in liquid detergent and water. Squeeze dry in a clean cloth. Saturate in engine oil. Squeeze in clean, absorbent cloth to remove all excess oil. Replace if very dirty or damaged.

3. Remove knob and plate. Carefully remove cartridge to prevent debris from entering carburetor. To service cartridge, clean by tapping gently on flat surface. Do not oil cartridge. Replace if very dirty or damaged.

**NOTE:** Do not use petroleum solvents, eg., kerosene, which will cause cartridge to deteriorate. Do not use pressurized air to clean cartridge. Pressurized air can damage cartridge.

4. Reinstall cartridge, plate and knob.
5. Reassemble pre-cleaner on cartridge.
6. Replace cover and reattach clips to body.

### AIR CLEANER ON FENDER

1. Remove end cap and filter element, clean by tapping gently on flat surface. Do not oil cartridge. Replace if very dirty or damaged.
2. Remove air cleaner cap and clean. Cap can be washed in solvent, make sure its dry before reinstalling.



## MAINTENANCE

### TIRE PRESSURE

Caution must be used when inflating a low tire to recommended pressure. Over inflating can cause tires to explode. Tires should be front 5 psi (.35 bar) and rear 20 psi (1.36 bar) maximum. Improper inflation will reduce tire life considerably.

### ENGINE OIL

Change and add oil according to chart below. Do not overfill. Use a high quality detergent oil classified "For Service SJ or higher" SAE 30 oil. Use no special additives with recommended oils. Do not mix oil with gasoline.

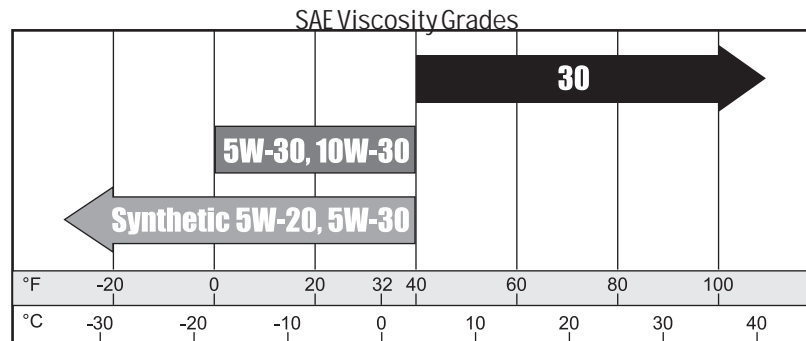

**Starting Temperature Range Anticipated Before Next Oil Change**

Air cooled engine run hotter than automotive engines. Use of multi-viscosity oils (10W-30, etc) above 40° F (4° C) will result in high oil consumption and possible engine damage. Check oil level more frequently if using these types of oils.

SAE 30 oil, if used below 40° F (4° C), will result in hard starting and possible engine bore damage due to inadequate lubrication.

### HYDRAULIC OIL

1. Use SAE 10W-40 API Service SJ or higher motor oil.
2. For proper warranty, change oil every 500 hours or annually, which ever is first.
3. The oil level should be 2" to 2 1/2" from top of fill neck when fluid is cold. Do not overfill.
4. After changing oil, run the machine for a few minutes. Check oil level and for leaks.
5. Always use caution when filling hydraulic oil tank or checking level to keep system free of contaminants. Check and service more frequently when operating in extremely cold, hot or dusty conditions.
6. If natural color of fluid is now black or smells burnt, it is possible that an overheating problem exists.
7. If fluid becomes milky, water contamination may be a problem.
8. If either of the above conditions happen, change oil and filter immediately after fluid is cool and find cause. Take fluid level readings when system is cold.
9. In extreme temperatures you can use straight weight oil. We recommend SAE 30W API Service SJ or higher when hot (above 90°F (33°C)) and SAE 10W API Service SJ or higher when cold (below 32°F (0°C) ambient temperature. Use either motor oil or hydraulic oil, but do not mix.
10. Oil being added to the system must be the same as what is already in the tank. Mark tank fill area as to which type you put in.

WHEEL MOUNTING PROCEDURE

1. Set park brake. Turn machine off and remove key.
2. Block one of the other wheels.
3. Loosen nuts slightly on wheel to be removed.
4. Jack up machine being careful not to damage underside of machine.
5. Remove nuts, remove wheel.
5. Place new wheel on hub lining up bolt holes.
6. Torque nuts to 64-74 ft/lb (87-100Nm) using a cross pattern. Retorque after first 10 hours and every 200 hours thereafter.
7. Lower machine to ground and remove blocks and jack.

BATTERY

Batteries normally produce explosive gases which can cause personal injury. Do not allow flames, sparks or any ignited object to come near the battery. When charging or working near battery, always shield your eyes and always provide proper ventilation.

Battery cable should be disconnected before using "Fast Charge".

Charge battery at 15 amps for 10 minutes or 7 amps for 30 minutes. Do not exceed the recommended charging rate. If electrolyte starts boiling over, decrease charging.

Always remove grounded (-) battery clamp first and replace it last. Avoid hazards by:

1. Filling batteries in well-ventilated areas.
2. Wear eye protection and rubber gloves.
3. Avoid breathing fumes when electrolyte is added.
4. Avoid spilling or dripping electrolyte.



**Battery Electrolyte is an acidic solution and should be handled with care. If electrolyte is splashed on any part of your body, flush all contact areas immediately with liberal amounts of water. Get medical attention immediately.**

JUMP STARTING



**Use of booster battery and jumper cables. Particular care should be used when connecting a booster battery. Use proper polarity in order to prevent sparks.**

To jump start (negative grounded battery):

1. Shield eyes.
2. Connect ends of one cable to positive (+) terminals of each battery, first (A) then (B).
3. Connect one end of other cable to negative (-) terminal of "good" battery (C).
4. Connect other end of cable (D) to engine block on unit being started (NOT to negative (-) terminal of battery)

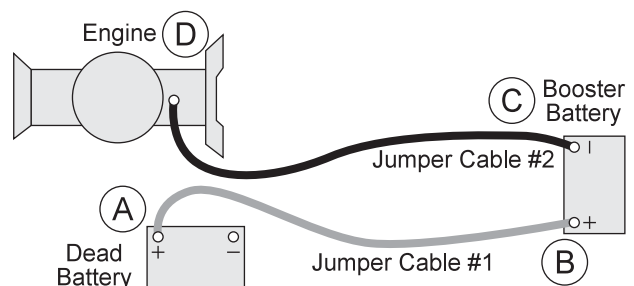

To prevent damage to other electrical components on unit being started, make certain that engine is at idle speed before disconnecting jumper cables.



## SERVICE CHART



Before servicing or making adjustments to the machine, stop engine, set park break, block wheels and remove key from ignition.



Follow all procedures and **ONLY** use parts prescribed by the manufacturer. Read the engine manual before maintenance.

The suggested maintenance checklist is not offered as a replacement for the manufacturer's engine manual but as a supplement. You must adhere to the guidelines established by the manufacturer for warranty coverage. In adverse conditions such as dirt, mud or extreme temperatures, maintenance should be more frequent.

Maintenance Service Interval	Maintenance Procedure
After the first 8 operating hours	Torque the wheel lug nuts. (64-74 ft/lb (87-100 Nm))
	Change the engine oil filter.
After the first 20 operating hours	Change oil filter after first 20 and first 100 hours.
Before each use daily	Check the engine oil.
	Check the hydraulic fluid level.
	Check the tire pressure.
	Check condition of hydraulic hoses and fittings.
	Inspect and clean the machine.
Every 25 hours	Inspect cooling system.
	Check the battery fluid level and cable connections.
Every 50 hours	Change oil when operating under heavy load or high
	Change the engine oil and filter.
Every 100 hours	Check engine for leaks or loose parts.
	Check air cleaner.
	Check tire pressure (5 psi (.035 bar) and 20 psi (1.4 bar)).
	Torque the wheel lug nuts. (64-74 ft/lb (87-100 Nm))
	Grease Machine.
Every 250 hours	Check belt tension (where needed)
	Change oil filter
Every 400 hours	Clean battery terminals
	Check spark plugs
Every 500 hours or yearly	Lubricate machine
	Visual inspection of machine and hydraulic hoses
	Change oil.
	Torque lug nuts.
	Check battery terminals and electrolyte level.
	Change all filters.



## ADJUSTMENTS

### REAR ATTACHMENT LIFT

The rear attachment lift has several adjustments. By moving the 1/2" clevis pin to different holes you can achieve several different lowering heights.

- A. Pin Storage Only - Do not use for holding up lift mechanism. Damage will occur.
- B. Dump Box - Proper lift storage when dump box is used.
- C. Attachment - Place 1/2" clevis pin in one hole to control attachment lowering limit. All three produce different lowering heights.
- D. Links can be reversed front or back to further tailor lowering limit height.

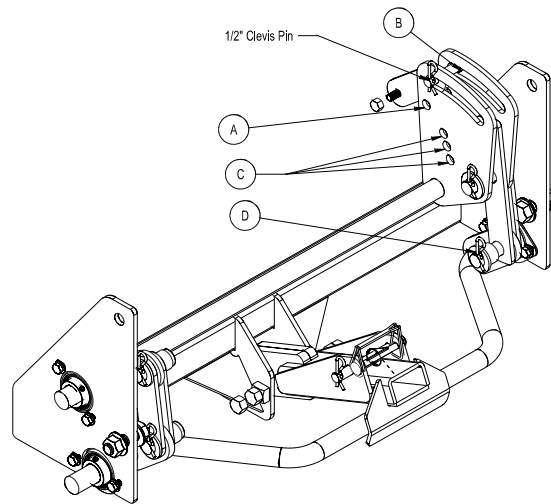

## STORAGE

If the engine will be out of service for two or more months, use the following storage procedure.

1. Clean the exterior surfaces of the engine.
2. Change the oil and filter while the engine is still warm from operation.
3. The fuel system must be completely emptied, or the gasoline must be treated with a stabilizer to prevent deterioration.

If you choose to use a stabilizer, follow manufacturers recommendations, and add the correct amount for the capacity of fuel system. Fill fuel tank with clean, fresh gasoline. Run engine for 2-3 minutes to get stabilized fuel into carburetor. Close fuel shut-off valve when unit is being stored or transported.

To empty the system, drain fuel tank and carburetor, or run engine until tank and system are empty.

4. Remove the spark plugs. Add one tablespoon of engine oil into each spark plug hole. Install plugs, but do not connect the plug leads. Crank the engine two or three revolutions.
5. Store machine in a clean, dry place.





# HYDRAULIC DIAGRAM

Diagrams

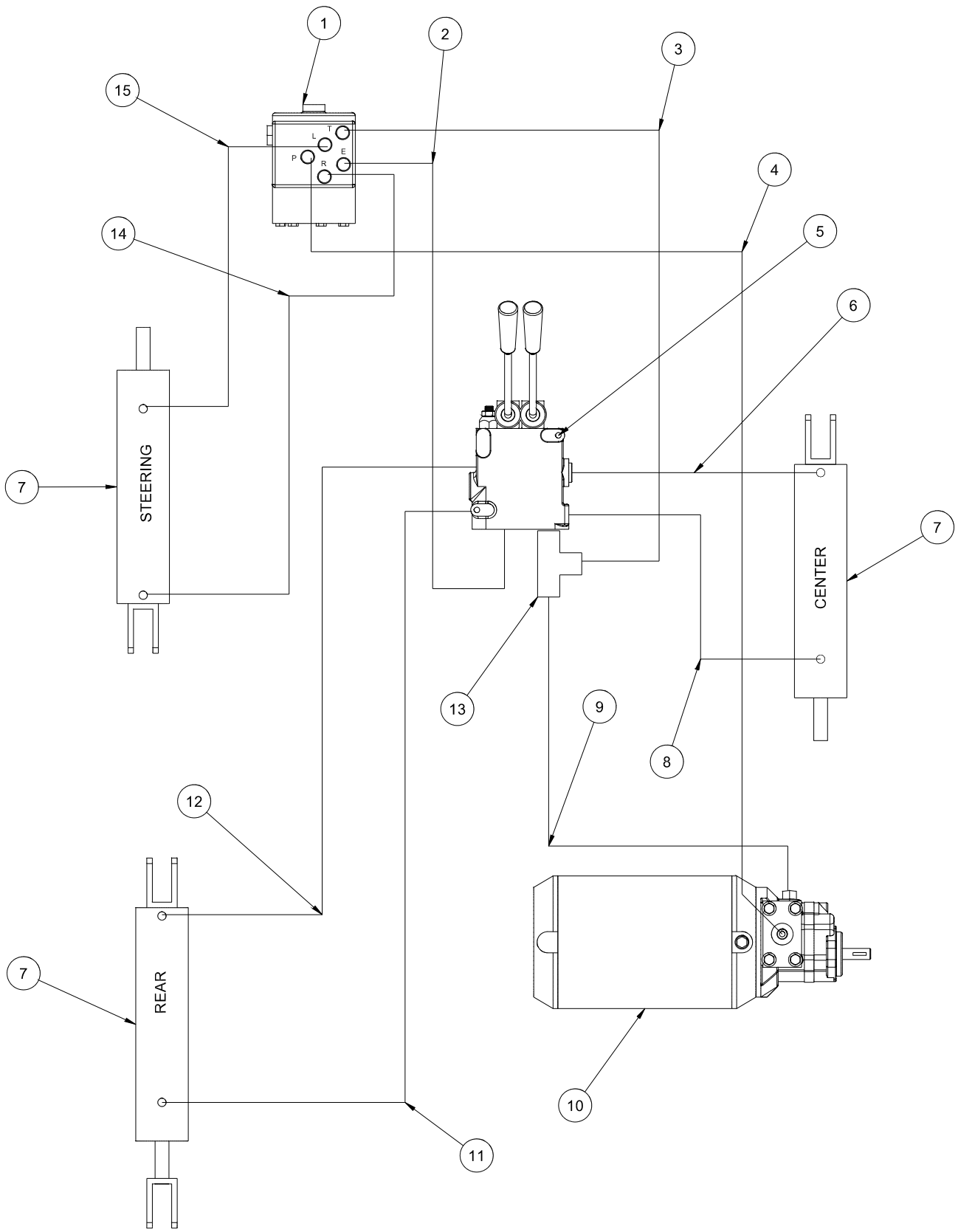

## HYDRAULIC DIAGRAM

REF#	PART#	DESCRIPTION	QUANTITY
1	34-103	Orbitrol	1
2	52-067	Hydraulic Hose	1
3	52-068	Hydraulic Hose	1
4	52-061	Hydraulic Hose	1
5	13-729	2-Bank Valve	1
6	52-065	Hydraulic Hose	1
7	75-714	Hydraulic Cylinder	1
8	52-066	Hydraulic Hose	1
9	52-062	Hydraulic Hose	1
10	15-315	Hydraulic Power Unit	1
	15-315-01	Repair Kit	1
11	52-063	Hydraulic Hose	1
12	52-064	Hydraulic Hose	1
13	18-190	Swivel Tee	1
14	52-069	Hydraulic Hose	1
15	52-070	Hydraulic Hose	1



# WIRING DIAGRAM

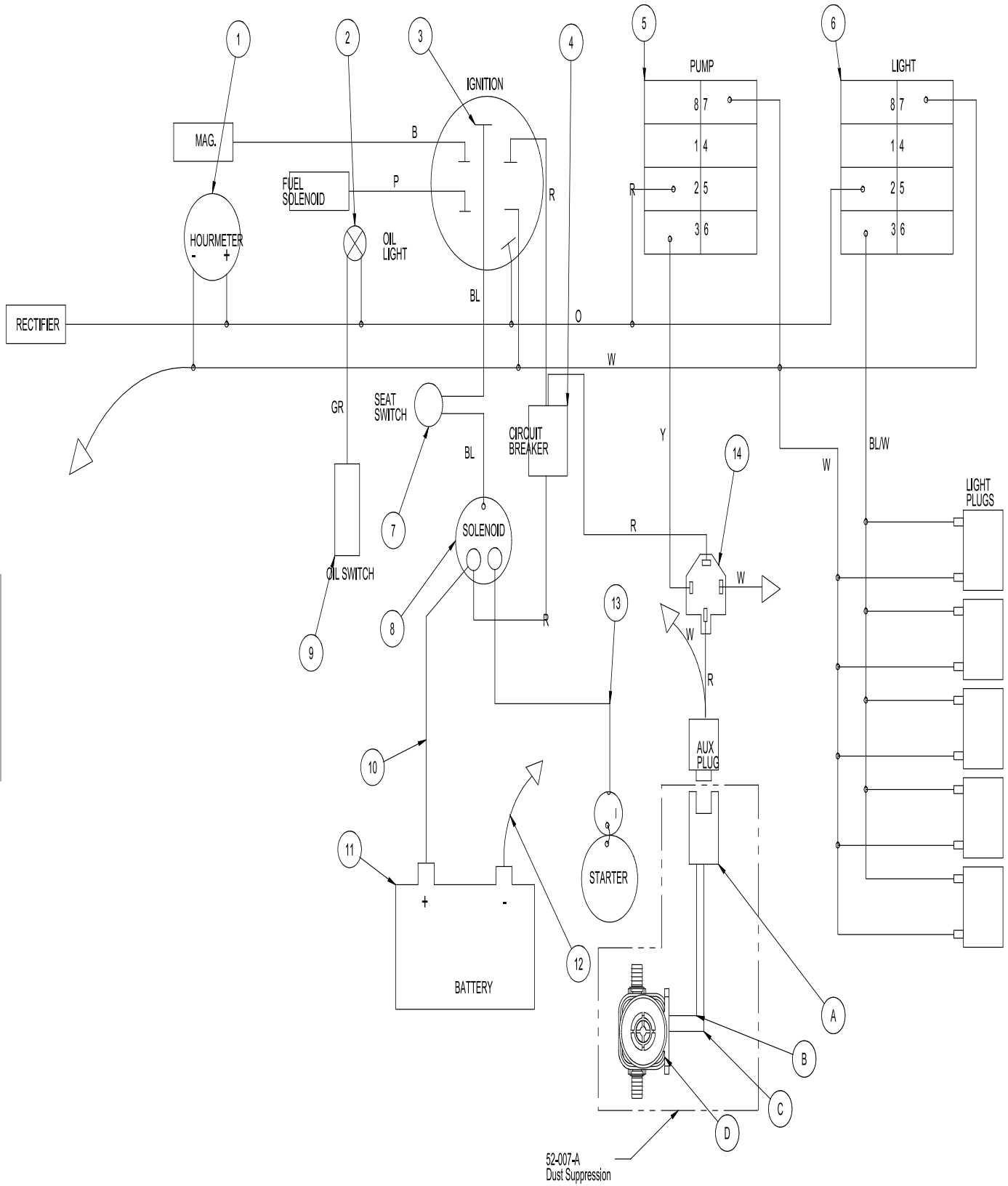

Parts



REF#	PART#	DESCRIPTION	QUANTITY
1	12-017	Hour Meter	1
2	50-359	Oil Light	1
3	13-488	Ignition Switch	1
4	8975	Circuit Breaker, 30 Amp	1
	8977	Circuit Breaker Boot. Red	1
5	Pump Switch		
	15-725	Panel Mount End	1
	15-727	Switch Actuator, No light	1
	15-782	Rocker Switch Unlit	1
6	Light Switch		
	15-725	Panel Mount End	1
	15-726	Switch Body, Light	1
	15-731	Actuator, Amber	1
7	14-292	Seat Switch	1
8	13-750	Solenoid w/ Connector	1
9	13-491	Oil Switch	1
10	22-055	Red Battery Cable (positive +)	1
11	22-073	Battery	1
12	48-147	Black Battery Cable (negative -)	1
13	13-197	Starter Cable Black	1
14	30-042-06	Relay	1
	52-043	Wire Harness	
52-007 Dust Suppression Kit			
A	9016	Weather Pack	1
	9017	Weather Pack Terminal	2
	9018	Seal	2
B	8850-96	Red Wire	1
C	8849-96	Black Wire	1
D	52-101	FloJet® Pump	1



# MAIN MACHINE

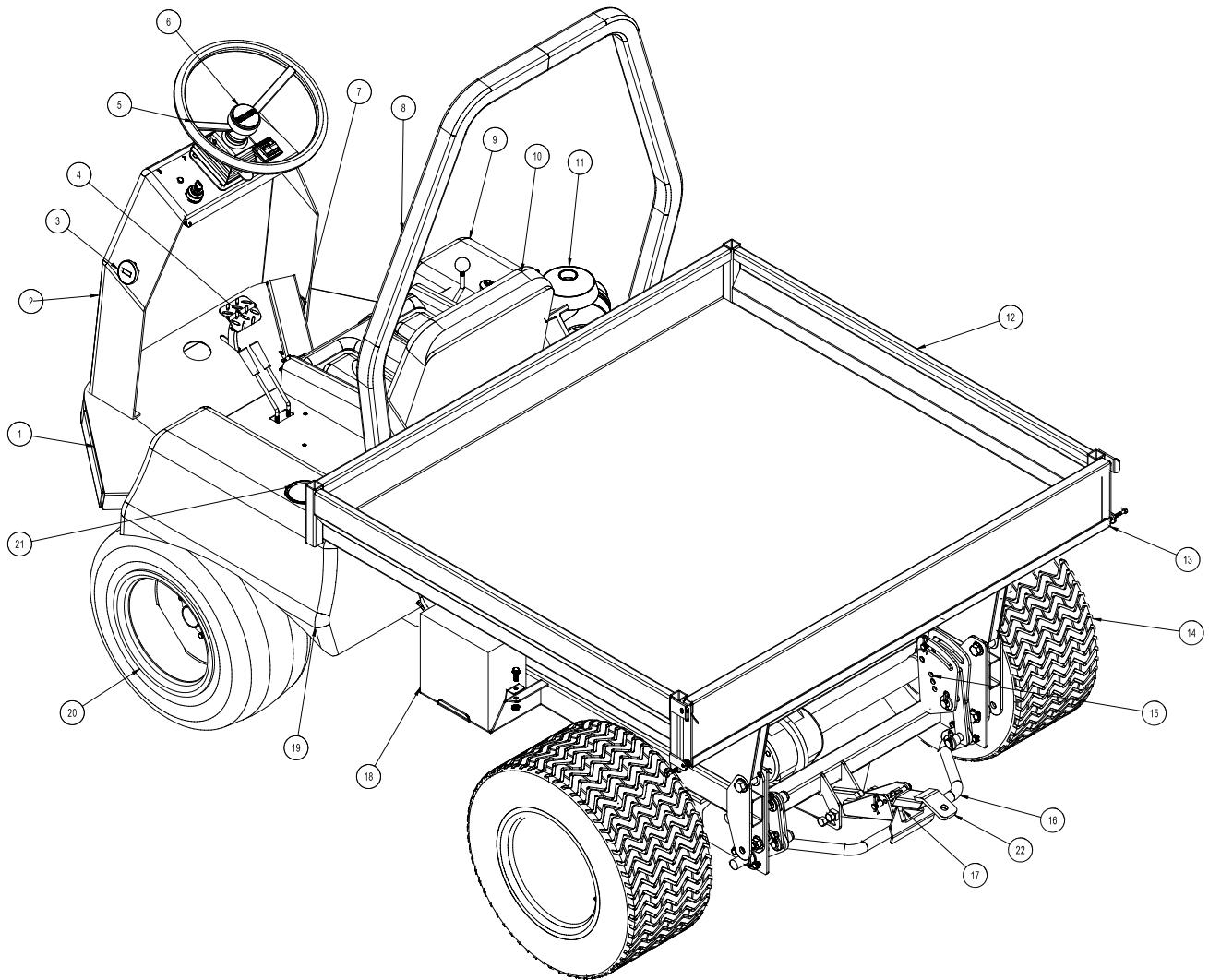

Parts

<b>REF#</b>	<b>PART#</b>	<b>DESCRIPTION</b>	<b>QUANTITY</b>
1	52-017	Mainframe	1
2	52-054	Nose Cone	1
3	12-017	Hour Meter	1
4	52-028	Brake Pedal	1
5	13-718	Steering Wheel	1
6	13-726	Center Cap	1
7	52-029	Gas Pedal	1
8	52-016	ROPs	1
9	52-053	Right Front Fender	1
10	14-518	Seat	1
11	42-076	Air Cleaner	1
12	52-072	Box	1
13	52-036	Tailgate	1
14	43-124	Turf Tire and Wheel	2
	43-123-01	Tire	2
	43-058-01	Wheel	2
15	52-114	Rear Lift Assembly	1
16	52-112	Lift bar	1
17	52-135	Quick Hitch Receiver	1
18	22-073	Battery	1
19	52-052	Left Front Fender	1
20	52-120	Front Tire & Wheel	2
	52-120-01	Tire	2
	16-857-02	Wheel	2
21	15-781	Drink Cup Holder	1
22	43-143	Tow Hitch	1



# NOSE CONE

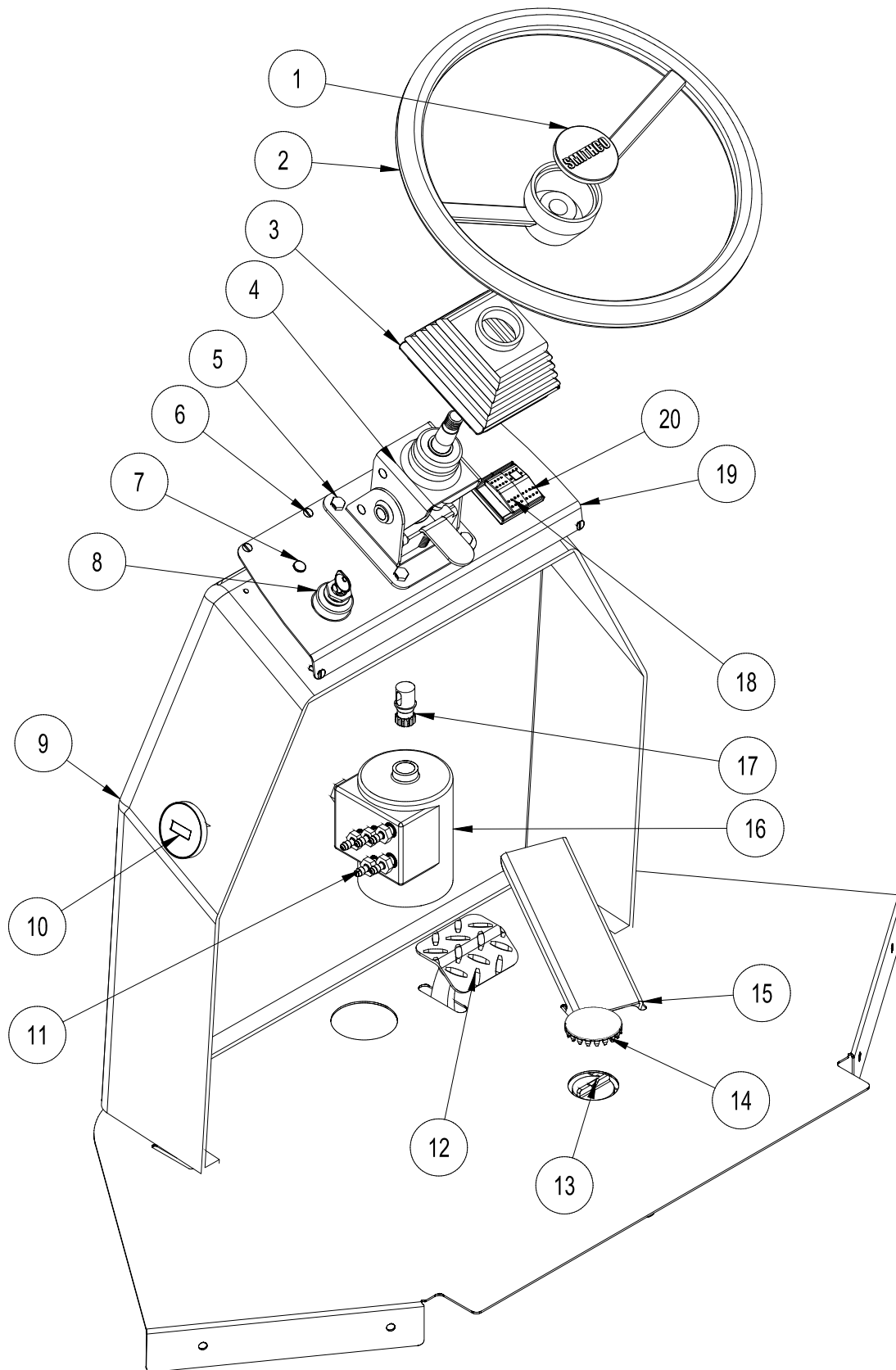

Parts



REF#	PART#	DESCRIPTION	QUANTITY
1	13-726	Center Cap	1
	27-077	Decal, Smithco	1
2	13-718	Steering Wheel	1
3	76-364	Boot	1
4	76-362	Mini Tilt Steering Column	1
5	HB-516-18-100	Bolt, $\frac{5}{16}$ - 18 x 1	4
	HNFL-516-18	Flange Lock Nut, $\frac{5}{16}$ -18	4
6	HSM-10-32-063	Machine Screw, #10 -32 x $\frac{5}{8}$	6
	HNFL-10-32	Flange Lock Nut, #10 -32	6
7	50-359	Warning Light	1
8	13-488	Ignition Switch	1
9	52-054	Nose Cone	1
10	12-017	Hour Meter	1
11	18-169	Adapter	5
12	52-028	Brake Pedal	1
13	50-123	Master Cylinder	1
14	25-199	Plug Button	1
15	52-029	Gas Pedal	1
16	34-103	Orbitrol	1
17	48-147	Stub Shaft	1
18	Lights		
	15-727	Switch Body, No Light	1
	15-782	Rocker Switch, Unlit	1
19	52-035	Dash Panel	1
	52-021	Decal, Dashboard	1
20	Pump		
	15-725	Panel Mount End	2
	15-726	Switch Body, Light	1
	15-731	Actuator, Amber	1



# LINKAGE AND BRAKES

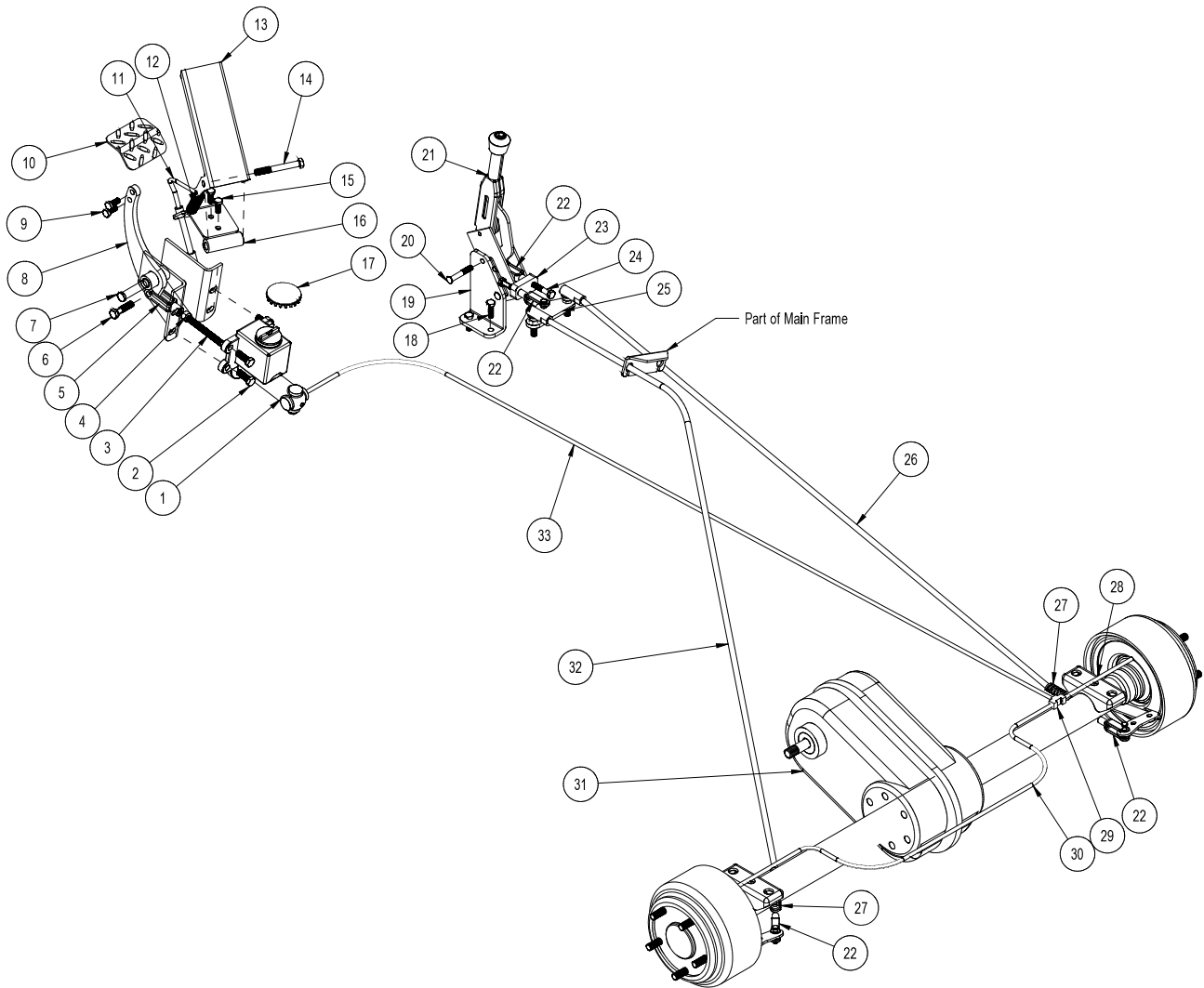

Parts

## LINKAGE AND BRAKES

REF#	PART#	DESCRIPTION	QUANTITY
1	50-123	Brake Cylinder	1
	8898	Brake Fluid	< 1 pint
2	HB-38-16-100	Bolt, $\frac{3}{8}$ - 16 x 1	4
	HNFL-38-16	Flange Lock Nut, $\frac{3}{8}$ - 16	4
3	52-133	Brake Rod	1
4	HN-38-24	Nut, $\frac{3}{8}$ - 24	1
5	21-351	Linkage Yoke, $\frac{3}{8}$ - 24	1
6	HB-38-16-150	Bolt, $\frac{3}{8}$ - 16 x $1\frac{1}{2}$	1
	HNTL-38-16	Lock Nut, $\frac{3}{8}$ - 16	1
7	HCP-12-250	Clevis Pin, $\frac{1}{2}$ x $2\frac{1}{2}$	1
	HP-18-100	Cotter Pin, $\frac{1}{8}$ x 1	1
8	52-027	Pedal Arm	1
9	HB-516-18-075	Bolt, $\frac{5}{16}$ - 18 x $\frac{3}{4}$	2
	HNFL-516-18	Flange Lock Nut, $\frac{5}{16}$ - 18	2
10	52-028	Brake Pedal	1
11	15-310	Throttle Cable	1
	17-153	Clevis	1
	17-155	Retainer	1
12	52-132	Extension Spring	1
13	52-029	Gas Pedal	1
14	HB-38-16-300	Bolt, $\frac{3}{8}$ -16 x 3	1
	HNFL-38-16	Flange Lock Nut, $\frac{3}{8}$ -16	1
15	HB-516-18-075	Bolt, $\frac{5}{16}$ - 18 x $\frac{3}{4}$	2
	HNFL-516-18	Flange Lock Nut, $\frac{5}{16}$ - 18	2
16	52-026	Gas Pedal Mount	1
	16-047	Plastic Bushing	2
17	25-199	Plug Button	1
18	HB-516-18-100	Bolt, $\frac{5}{16}$ - 18 x 1	2
	HNFL-516-18	Flange Lock Nut, $\frac{5}{16}$ - 18	2
19	52-018	Park Brake Mount	1
20	HB-516-18-200	Bolt, $\frac{5}{16}$ -18 x 2	2
	HNFL-516-18	Flange Lock Nut, $\frac{5}{16}$ - 18	2
21	60-106	Brake Lever	1
22	11-100	Linkage Yoke, $\frac{5}{16}$	4
23	52-074	Cable Block	1
24	HB-516-24-150	Bolt, $\frac{5}{16}$ - 24 x $1\frac{1}{2}$	2
25	52-075	Brake Cable Connector	1
26	52-049	RH Brake Cable	1
27	19-205	Spring	2
28	51-129	Brake Line, 8"	1
29	18-0089	Tee	1
30	51-131	Brake Line, 40"	1
31	15-038	Axle	1
32	52-048	LH Brake Cable	1
33	16-189	Brake Line, 74"	1



# FRONT AXLE

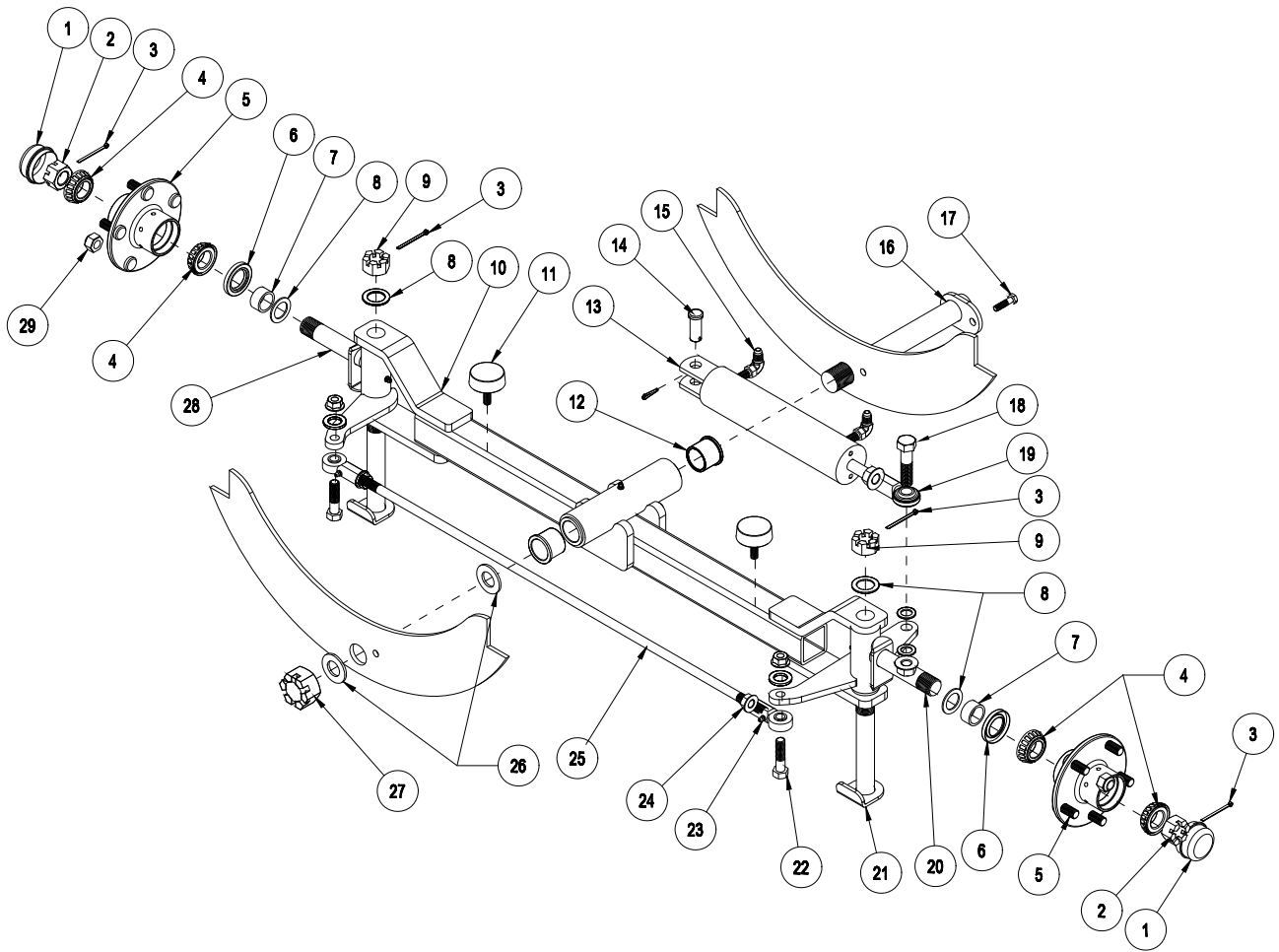

Parts

## FRONT AXLE

REF#	PART#	DESCRIPTION	QUANTITY
1*	80-167	Dust Cap	2
2	HNAR-100-14	Slotted Jam Nut, 1 - 14	2
3	HP-18-150	Cotter Pin, $\frac{1}{8}$ - $1\frac{1}{2}$	4
4*	11-043	Bearing	4
5*	80-019	Hub (includes all * items)	2
6*	11-041	Oil Seal	2
7	11-042	Spacer	2
8	HMB-100-14	Machine Bushing, 1 x 14GA	4
9	HNA-100-14	Slotted Hex Nut, 1 - 14	2
10	52-022	Front Axle	1
11	50-081	Rubber Bumper	2
	HNFL-38-16	Flange Lock Nut, $\frac{3}{8}$ - 16	2
12	18-153	Bushing (part of 52-022)	2
13	75-714	Hydraulic Cylinder	1
14	HCP-58-175	Clevis Pin, $\frac{5}{8}$ - $1\frac{3}{4}$	1
	HP-18-100	Cotter Pin, $\frac{1}{8}$ x 1	1
15	18-168	Straight Thread 90° Elbow	2
16	52-138	Axle Pin	1
17	HB-516-18-125	Bolt, $\frac{5}{16}$ - 18 x $1\frac{1}{4}$	1
	HNTL-516-18	Lock Nut, $\frac{5}{16}$ - 18	1
18	HB-58-11-250	Bolt, $\frac{5}{8}$ - 11 x $2\frac{1}{2}$	1
	HMB-58-14	Machine Bushing, $\frac{5}{8}$ x 14GA	2
	HNTL-58-11	Lock Nut, $\frac{5}{8}$ - 11	1
19	18-154	Rod End	1
	HG-14-28-180	Grease Fitting	1
20	52-023	Right Spindle	1
21	16-076	King Pin	2
22	HB-12-13-200	Bolt, $\frac{1}{2}$ - 13 x 2	2
	HMB-12-14	Machine Bushing, $\frac{1}{2}$ x 14GA	2
	HNTL-12-13	Lock Nut, $\frac{1}{2}$ - 13	2
23	80-006	Rod End w/ Grease Fitting	12
24	HNJ-12-20	Jam Nut, $\frac{1}{2}$ - 20	2
25	52-089	Tie Rod	1
26	HMB-114-10	Machine Bushing, $1\frac{1}{4}$ x 10GA	2
27	HNAT-114-12	Thick Slotted Jam Nut, $1\frac{1}{4}$ - 12	1
28	52-024	Left Spindle	1
29	HNL-12-20	Lug Nut, $\frac{1}{2}$ - 20	10



# SEAT PANEL

Parts

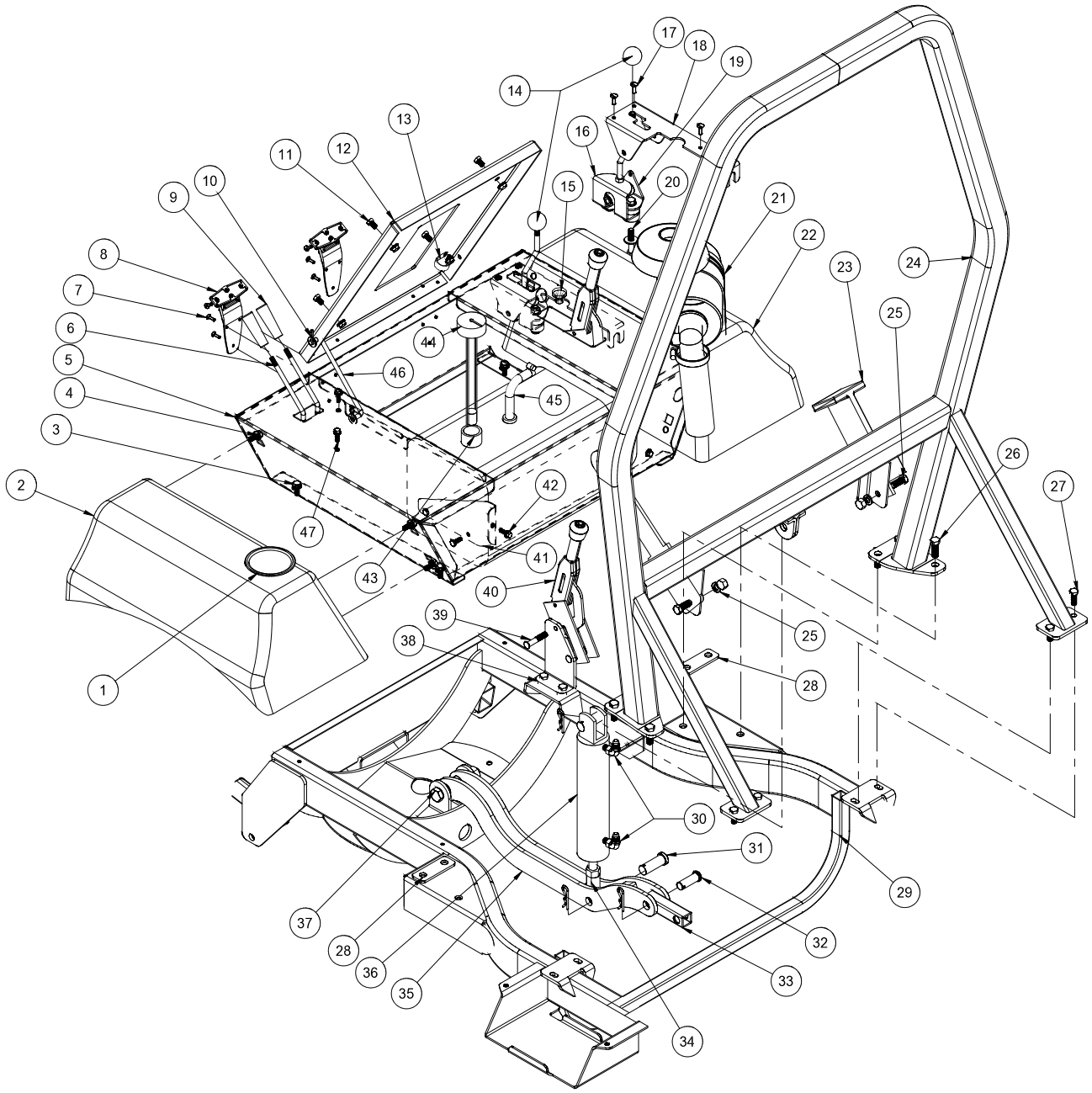

REF#	PART#	DESCRIPTION	QUANTITY
1	15-781	Drink Cup Holder	1
2	52-052	Left Front Fender	1
3	HBFL-516-18-075	Flange Lock Bolt, $\frac{5}{16}$ - 18 x $\frac{3}{4}$	4
	HNFL-516-18	Flange Lock Nut, $\frac{5}{16}$ - 18	4
4	HBFL-516-18-075	Flange Lock Bolt, $\frac{5}{16}$ - 18 x $\frac{3}{4}$	6
	HNEU-516-18	Extruded U-Nut, $\frac{5}{16}$ - 18	6
5	52-073	Seat Frame	1
6	78-418	Valve Handle	2
7	HSMFCS-10-32-050	Machine Screw, 10-32 x $\frac{1}{2}$	12
	HNFL-10-32	Flange Lock Nut, 10-32	12
8	27-055	Hinge	2
9		Tapered Knob	2
10	HW-38	Washer, $\frac{3}{8}$	2
	HP-18-100	Cotter Pin, $\frac{1}{8}$ x 1	2
11	HBFL-516-18-075	Flange Lock Bolt, $\frac{5}{16}$ - 18 x $\frac{3}{4}$	4
	HNFL-516-18	Flange Lock Nut, $\frac{5}{16}$ - 18	4
12	52-141	Seat Panel	1
13	HLC-A-58	Loom Clamp	1
14	15-014	Shifter Knob	1
15	80-020	Choke	1
16	52-025	Shifter Arm	1
17	HSTP-14-20-075	Machine Screw, $\frac{1}{4}$ - 20 x $\frac{3}{4}$	3
18	52-019	Shifter Plate	1
19	52-125	Shift Linkage	1
	52-124	Rubber Bumper	2
20	HB-38-16-200	Bolt, $\frac{3}{8}$ - 16 x 2	2
	HW-38	Washer, $\frac{3}{8}$	2
	HNTL-38-16	Lock Nut, $\frac{3}{8}$ - 16	2
21	42-076	Air Cleaner	1
	HB-516-18-150	Bolt, $\frac{5}{16}$ - 18 x $1\frac{1}{2}$	2
	HW-516	Washer, $\frac{5}{16}$	2
	HNFL-516-18	Flange Lock Nut, $\frac{5}{16}$ - 18	2
22	52-053	Right Front Fender	1
23	76-198-03	Seat Belt	1
24	52-016	ROPs	1
25	HB-716-14-100	Bolt, $\frac{7}{16}$ - 14 x 1	2
	HWL-716	Lockwasher, $\frac{7}{16}$	2
	HN-716-14	Nut, $\frac{7}{16}$ - 14	2
26	HB-716-14-125	Bolt, $\frac{7}{16}$ - 14 x $1\frac{1}{4}$	6
	HWL-716	Lockwasher, $\frac{7}{16}$	6
	HN-716-14	Nut, $\frac{7}{16}$ - 14	6
27	HB-38-16-1000	Bolt, $\frac{3}{8}$ - 16 x 1	4
	HNFL-38-16	Flange Lock Nut, $\frac{3}{8}$ - 16	4
28	52-020	ROPs Spacer	2
29	52-017	Main Frame	1
30	18-168	Straight Thread 90° Elbow	2
31	HCP-34-200	Clevis Pin, $\frac{3}{4}$ x 2	2
	HHP-18	Bridge Pin, $\frac{1}{8}$	2
32	HCP-58-200	Clevis Pin $\frac{5}{8}$ x 2	1
	HHP-18	Bridge Pin, $\frac{1}{8}$	1
33	52-031	Lift Link	1
34	18-154	Rod End	1
	HNJ-58-18	Jam Nut, $\frac{5}{8}$ - 18	1

(Continued on Next Page)



# SEAT PANEL

Parts

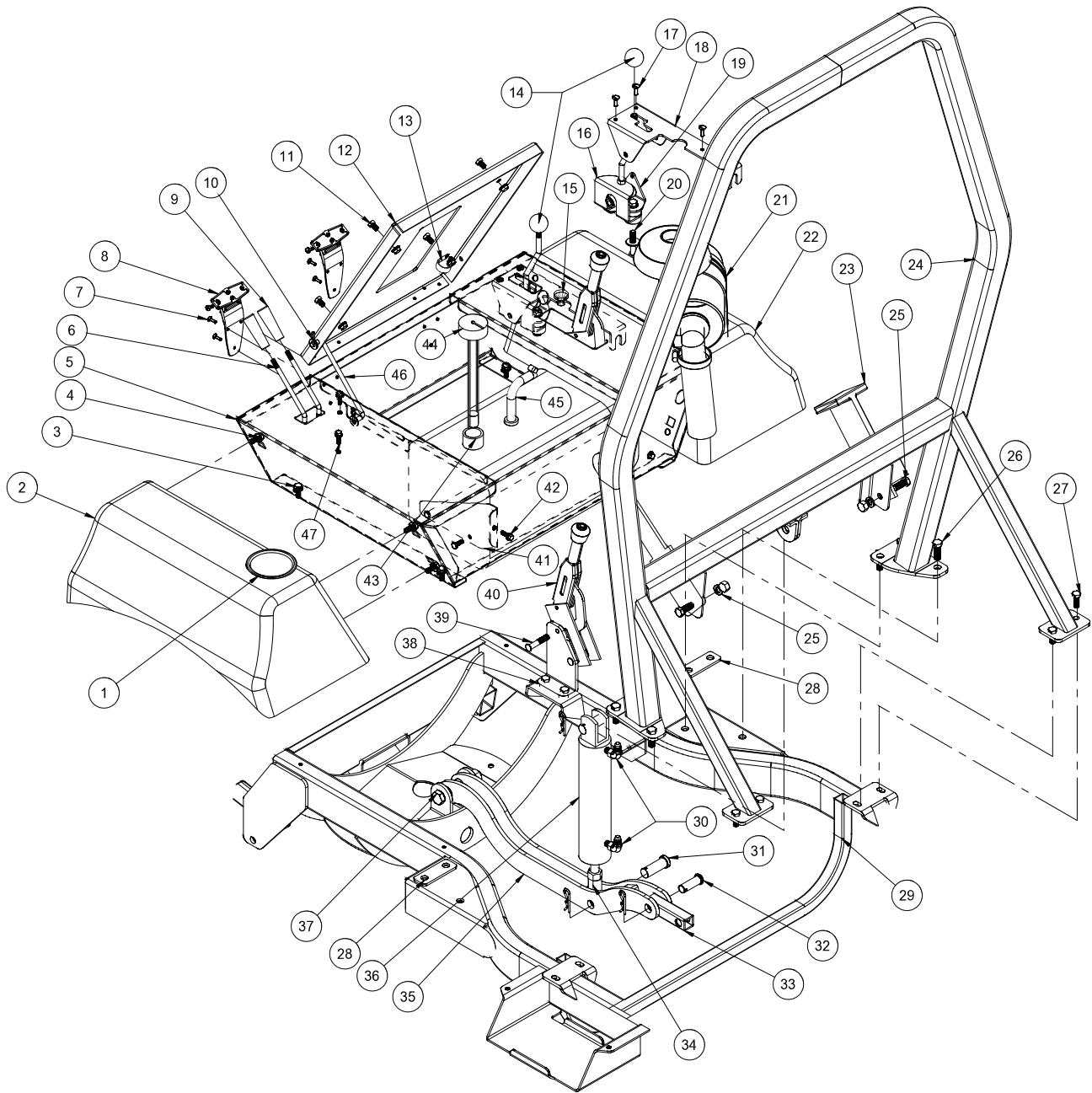



REF#	PART#	DESCRIPTION	QUANTITY
35	52-030	Center Lift	1
36	75-714	Cylinder	1
37	HB-58-11-400	Bolt, $\frac{5}{8}$ - 11 x 4	1
	HNTL-58-11	Lock Nut, $\frac{5}{8}$ -11	1
38	52-018	Brake Bracket	1
	HB-516-18-100	Bolt, $\frac{5}{16}$ -18 x 1	2
	HNFL-516-18	Flange Lock Nut, $\frac{5}{16}$ -18	2
39	HB-516-18-200	Bolt, $\frac{5}{16}$ - 18 x 2	2
	HNFL-516-18	Flange Lock Nut, $\frac{5}{16}$ -18	2
40	60-106	Park Brake	1
41	52-079	Left Fuel Tank Mount	1
	52-078	Right Fuel Tank Mount	1
42	HB-14-20-075	Bolt, $\frac{1}{4}$ - 20 x $\frac{3}{4}$	6
	HW-14	Washer, $\frac{1}{4}$	4
	HWL-14	Lockwasher, $\frac{1}{4}$	4
	HNFL-14-20	Flange Lock Nut, $\frac{1}{4}$ - 20	2
43	8-571	Fuel Tank with Cap	1
44	13-588	Fuel Cap with Gauge (replacement)	1
45	8800-36	Fuel Hose	1
	18-186	Hose Clamp	2
46	52-136	Hood Rod	1
47	HB-14-20-075	Bolt, $\frac{1}{4}$ - 20 x $\frac{3}{4}$	2
	HNFL-14-20	Flange Lock Nut, $\frac{1}{4}$ - 20	2



# ENGINE AND EXHAUST

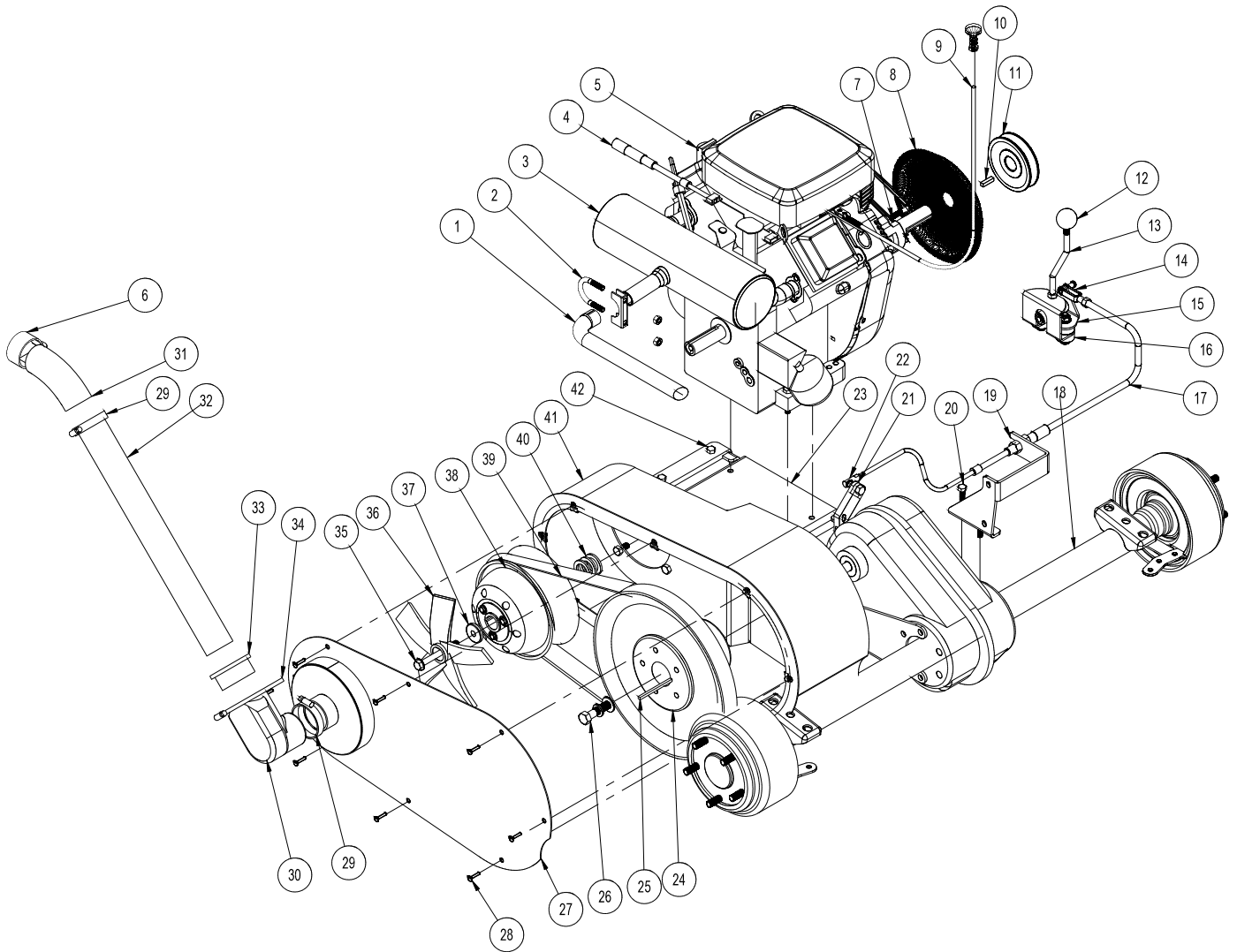

Parts

REF#	PART#	DESCRIPTION	QUANTITY
1	13-493	Tailpipe	1
2	13-498	Muffler Clamp	1
3	42-600	Muffler	1
4	15-310	Throttle Cable	1
	21-161	Wire Block	1
5	15-165	Briggs & Stratton Engine 16HP	1
	13-491	Oil Switch	1
6	52-137	Loom Clamp	1
7	52-055	Stub Shaft	1
	52-056	Stub Shaft Bolt	2
8	52-057	Screen	1
9	80-020	Choke Cable	1
	52-086	Cable Clamp	1
10	HKSQ-14-150	Square Key, $\frac{1}{4} \times 1\frac{1}{2}$	1
11	11-013	Pulley	1
	16-601	Belt	1
12	15-014	Shift Knob	1
13	52-025	Shift Handle	1
14	11-103	Linkage Yoke	1
15	52-125	Shift Linkage	1
16	52-124	Rubber Bumper	1
17	34-024	Push Pull cable	1
18	52-038	Axle	1
19	52-033	Shift Cable Mount	1
20	HB-516-18-100	Bolt, $\frac{5}{16}$ - 18 x 1	2
	HNTL-516-18	Lock Nut, $\frac{5}{16}$ - 18	2
21	52-106	Shaft Input Adapter	1
22	18-115	Ball Joint	1
23	52-034	Engine Mount	1
	HB-516-18-075	Bolt, $\frac{5}{16}$ - 18 x $\frac{3}{4}$	4
	HNTL-516-18	Lock Nut, $\frac{5}{16}$ - 18	4
24	52-045	Driven Converter	1
25	HKSQ-316-300	Square Key, $\frac{3}{16} \times 3$	1
26	HB-12-20-200	Bolt, $\frac{1}{2}$ - 20 x 2	1
	HW-12	Washer, $\frac{1}{2}$	1
	HWL-12	Lockwasher, $\frac{1}{2}$	1
27	52-042	Belt Guard Cover	1
28	HSTP-14-20-075	Phillips Machine Screw, $\frac{1}{4}$ - 20 x $\frac{3}{4}$	8
	78-274	Cage Nut Type J	8
29	18-123	Hose Clamp	2
	9024	Plastic Clamp Cover	2
30	52-059	Cobra Elbow	1
31	52-058	45° Elbow	1
32	52-134	Vent Tube	1
33	52-060	Insert	1
34	18-147	Hose Clamp	1
	9024	Plastic Clamp Cover	1
35	HB-38-24-350	Bolt, $\frac{3}{8}$ - 24 x $3\frac{1}{2}$	1
	HWL-3/8	Lockwasher, $\frac{3}{8}$	1

(Continued on Next Page)



# ENGINE AND EXHAUST

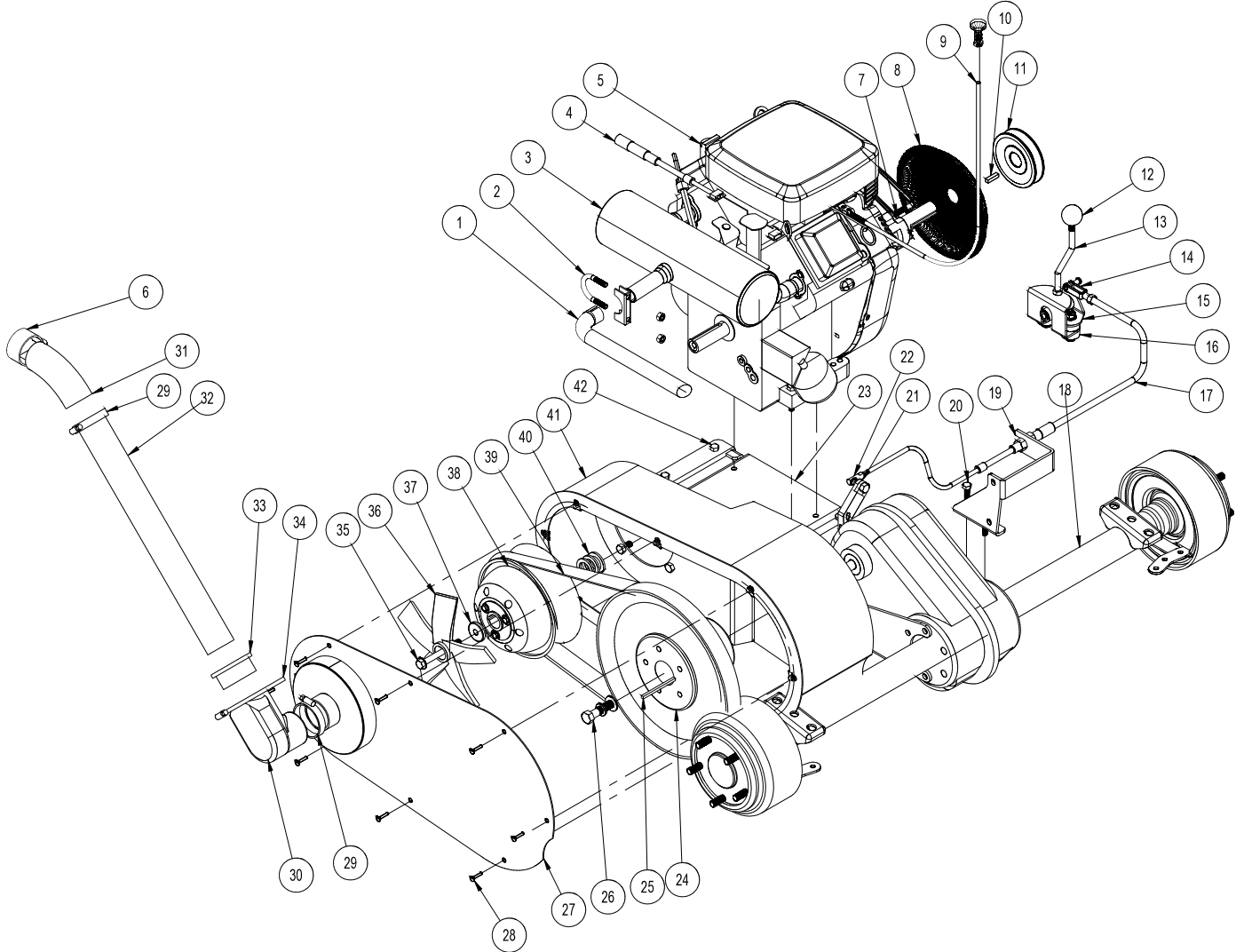

Parts

## ENGINE AND EXHAUST

REF#	PART#	DESCRIPTION	QUANTITY
36	52-071	Driver Fan	1
37	52-047	Driver Washer	1
38	52-044	Drive Converter	1
39	52-046	Drive Belt	1
40	HMB-100-10	Machine Bushing, 1 x 10GA	3
41	52-041	Belt Guard Case	1
	HB-38-16-075	Bolt, $\frac{3}{8}$ - 16 x $\frac{3}{4}$	4
	HWL-38	Lockwasher, $\frac{3}{8}$	4
42	HB-516-18-200	Bolt, $\frac{5}{16}$ - 18 x 2	2
	HW-516	Washer, $\frac{5}{16}$	2
	HNTL-516-18	Lock Nut, $\frac{5}{16}$ - 18	2



# POWER UNIT

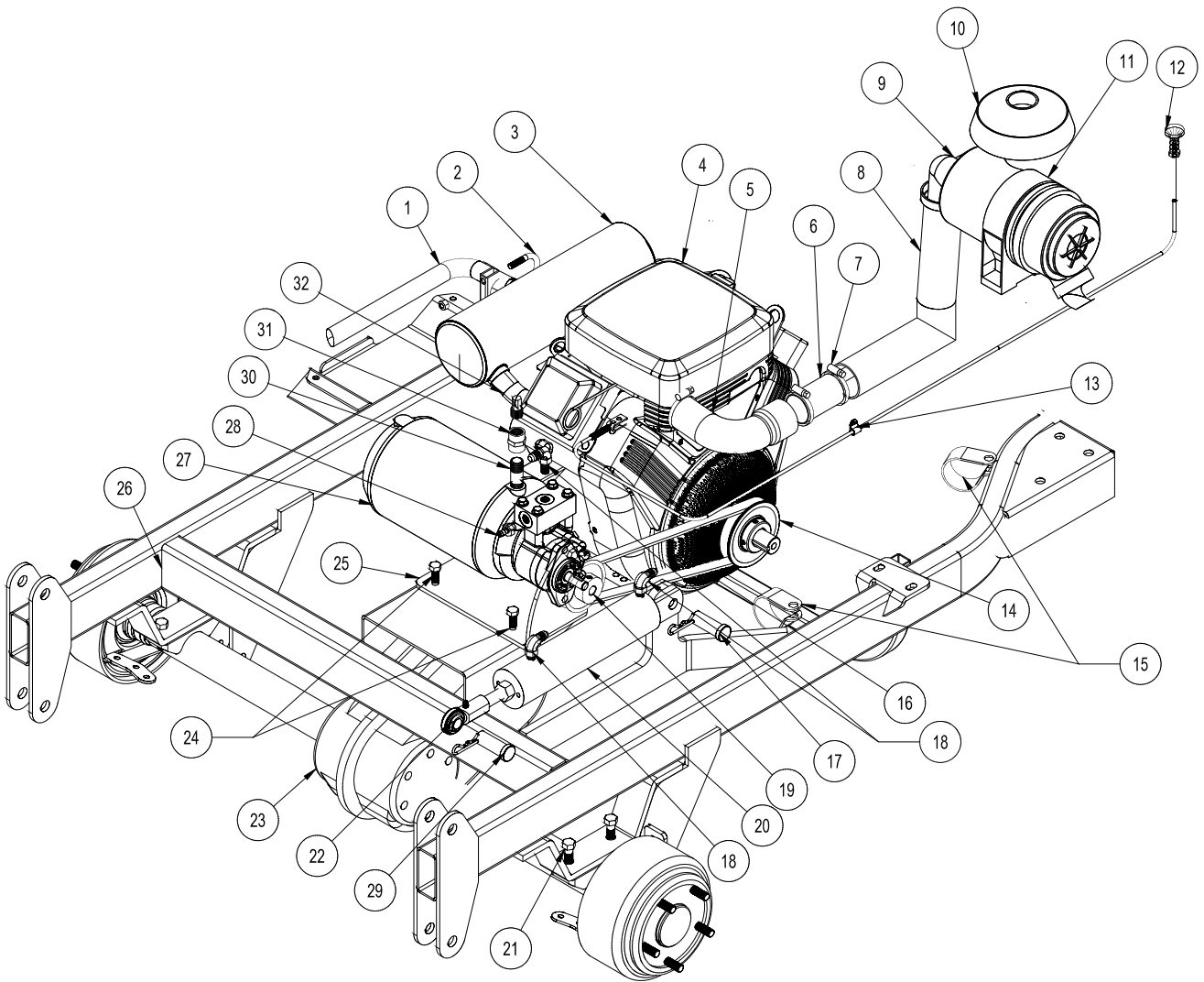

Parts

REF#	PART#	DESCRIPTION	QUANTITY
1	13-493	Tailpipe	1
2	13-498	Muffler Clamp	1
3	42-600	Muffler	1
4	15-165	Engine	1
5	27-113	Rubber Elbow	1
6	42-776	Air Cleaner Hose Sleeve	1
7	18-116	Hose Clamp	4
	9024	Plastic Cover	4
8	8959-27	Flex Hose, 27"	1
9	42-076	Air Cleaner	1
10	42-076-02	Hood	1
11	42-076-01	Band	1
12	80-020	Choke Cable	1
13	52-086	Cable Clamp	1
14	11-013	Pulley	1
15	HLC-A-200	Loom Clamp	2
	HSDPS-14-075	Pan Head Drill Screw, $\frac{1}{4} \times \frac{3}{4}$	2
16	16-601	Belt	1
17	HCP-34-200	Clevis Pin, $\frac{3}{4} \times 2$	1
	HHP-18	Bridge Pin, $\frac{1}{8}$	1
18	18-168	Straight Thread 90° Elbow	3
19	15-414	Pulley	1
20	75-714	Cylinder	1
21	HB-716-14-125	Bolt, $\frac{7}{16}$ - 14 x $1\frac{1}{4}$	4
	HWL-716	Lockwasher, $\frac{7}{16}$	4
	HN-716-14	Nut, $\frac{7}{16}$ - 14	4
22	18-154	Yoke End	1
	HG-14-28-180	Grease Fitting, $\frac{1}{8}$ - 28 x 180°	1
23	52-038	Axle	1
24	HB-516-18-100	Bolt, $\frac{5}{16}$ - 18 x 1	4
	HNFL-516-18	Flange Lock Nut, $\frac{5}{16}$ -18	4
25	52-084	Pump Mount	1
	HB-38-16-100	Bolt, $\frac{3}{8}$ - 16 x 1	2
	HNTL-38-16	Lock Nut, $\frac{3}{8}$ - 16	2
26	52-017	Main Frame	1
27	15-315	Hydraulic Power Unit	1
28	18-169	SAE Adapter	1
29	HCP-34-250	Clevis Pin, $\frac{3}{4} \times 2\frac{1}{2}$	1
	HHP-18	Bridge Pin, $\frac{1}{8}$	1
30	18-287	Pipe Nipple	1
31	18-314	$\frac{3}{8}$ Nipple	1
32	27-059	Breather	1



# HITCH AND BOX ASSEMBLY

Parts

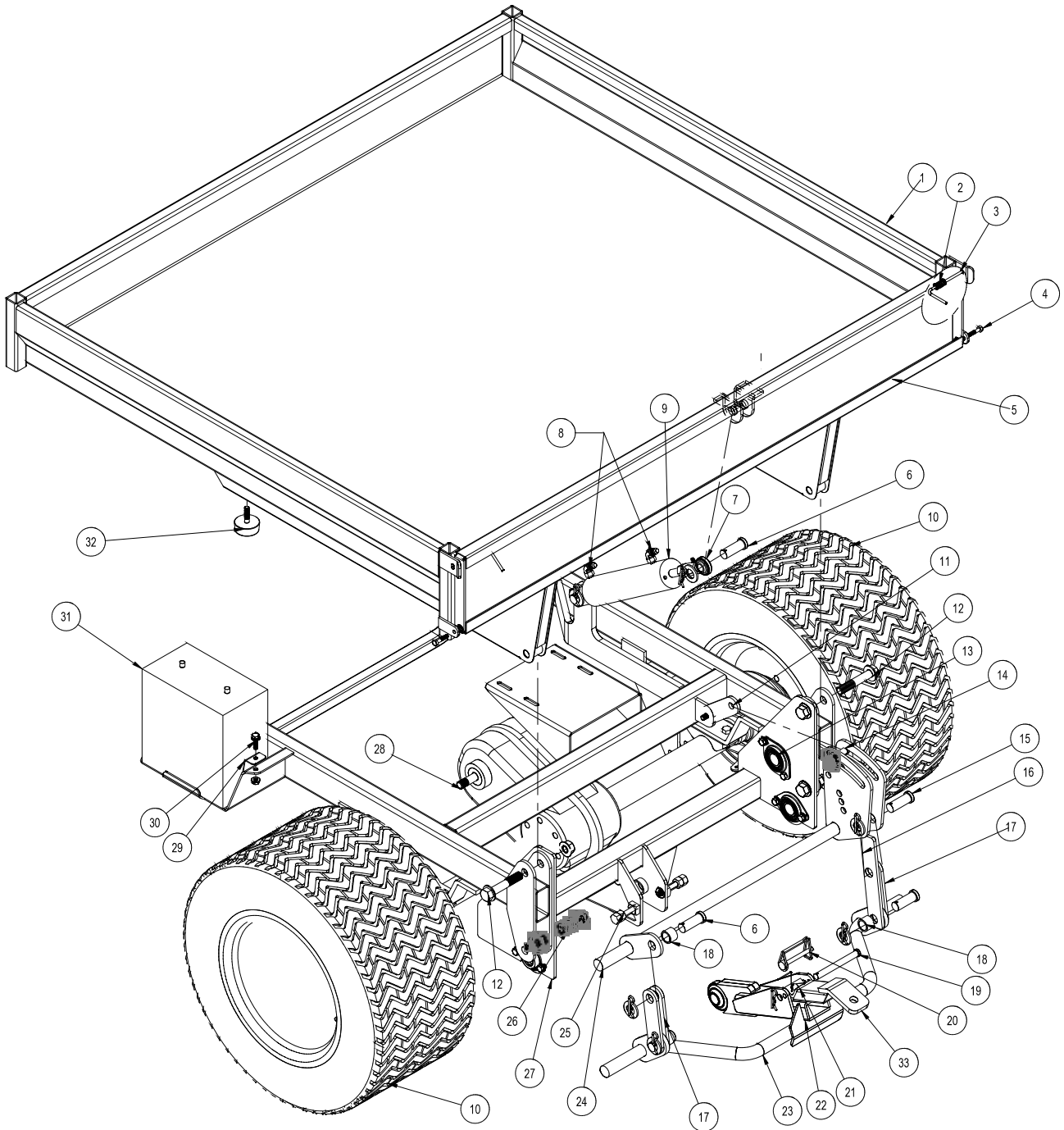



## HITCH AND BOX ASSEMBLY

REF#	PART#	DESCRIPTION	QUANTITY
1	52-072	Box	1
2	52-140	$\frac{5}{16}$ Retaining Ring	4
	8869-.875	Spring	2
3	52-139	Tailgate Rod	2
4	HB-14-20-125	Bolt, $\frac{1}{4}$ - 20 x $1\frac{1}{4}$	2
	HNFL-14-20	Flange Lock Nut, $\frac{1}{4}$ -20	4
5	52-036	Tailgate	1
6	HCP-34-200	Clevis Pin, $\frac{3}{4}$ x 2	5
	HHP-18	Bridge Pin, $\frac{1}{8}$	5
7	18-154	Rod End	1
	HNJ-58-18	Jam Nut, $\frac{5}{8}$ - 18	1
8	18-168	Straight Thread 90° Elbow	2
9	75-714	Cylinder	1
10	43-124	Turf Tire and Wheel	2
	43-123-01	Tire	2
	43-058-01	Wheel	2
11	52-108	Lock Strap	1
12	HB-58-11-350	Bolt, $\frac{5}{8}$ - 11 x $3\frac{1}{2}$	2
	HW-58	Washer, $\frac{5}{8}$	2
	HNTL-58-11	Lock Nut, $\frac{5}{8}$ - 11	2
13	13-391	Flange Bearing with Holder	4
	HBFL-516-18-075	Flange Bolt, $\frac{5}{16}$ - 18 x $\frac{3}{4}$	8
	HNFL-516-18	Flange Lock Nut, $\frac{5}{16}$ - 18	8
14	HCP-12-250	Clevis Pin, $\frac{1}{2}$ x $2\frac{1}{2}$	1
	HHP-18	Bridge Pin, $\frac{1}{8}$	1
15	HCP-34-250	Clevis Pin, $\frac{3}{4}$ x $2\frac{1}{2}$	1
	HHP -18	Bridge Pin, $\frac{1}{8}$	1
16	52-121	Limit Strap	1
17	52-119	Link Strap	3
18	52-131	Spacer	3
19	HCP-78-350	Clevis Pin, $\frac{7}{8}$ x $3\frac{1}{2}$	1
	HHP-18	Bridge Pin, $\frac{1}{8}$	1
20	25-382	Wire Lock Pin	1
21	43-136	Torsion Spring	1
22	52-135	Quick Hitch Receiver	1
23	52-112	Lift Bar	1
	15-019	Grip	2
24	52-113	Relay Bar	1
25	HSSH-12-13-175	Socket Head Cap Screw, $\frac{1}{2}$ - 13 x $1\frac{3}{4}$	2
	HN-12-13	Nut, $\frac{1}{2}$ - 13	4
26	HB-58-11-200	Bolt, $\frac{5}{8}$ - 11 x 2	2
	HW-58	Washer, $\frac{5}{8}$	5
	HNTL-58-11	Lock Nut, $\frac{5}{8}$ - 11	2
27	52-114	Rear Lift Assembly	1
28	52-038	Axle	1
29	52-077	Battery Hold Down	2
30	HBFL-516-18-100	Flange Bolt, $\frac{5}{16}$ - 18 x 1	2
	HNFL-516-18	Flange Lock Nut, $\frac{5}{16}$ -18	2
31	22-073	Battery	1
32	50-081	Rubber Bumper	2
	HNFL-38-16	Flange Lock Nut, $\frac{3}{8}$ - 16	2
33	43-143	Tow Hitch	1



# 13-729 2-BANK HYDRAULIC VALVE

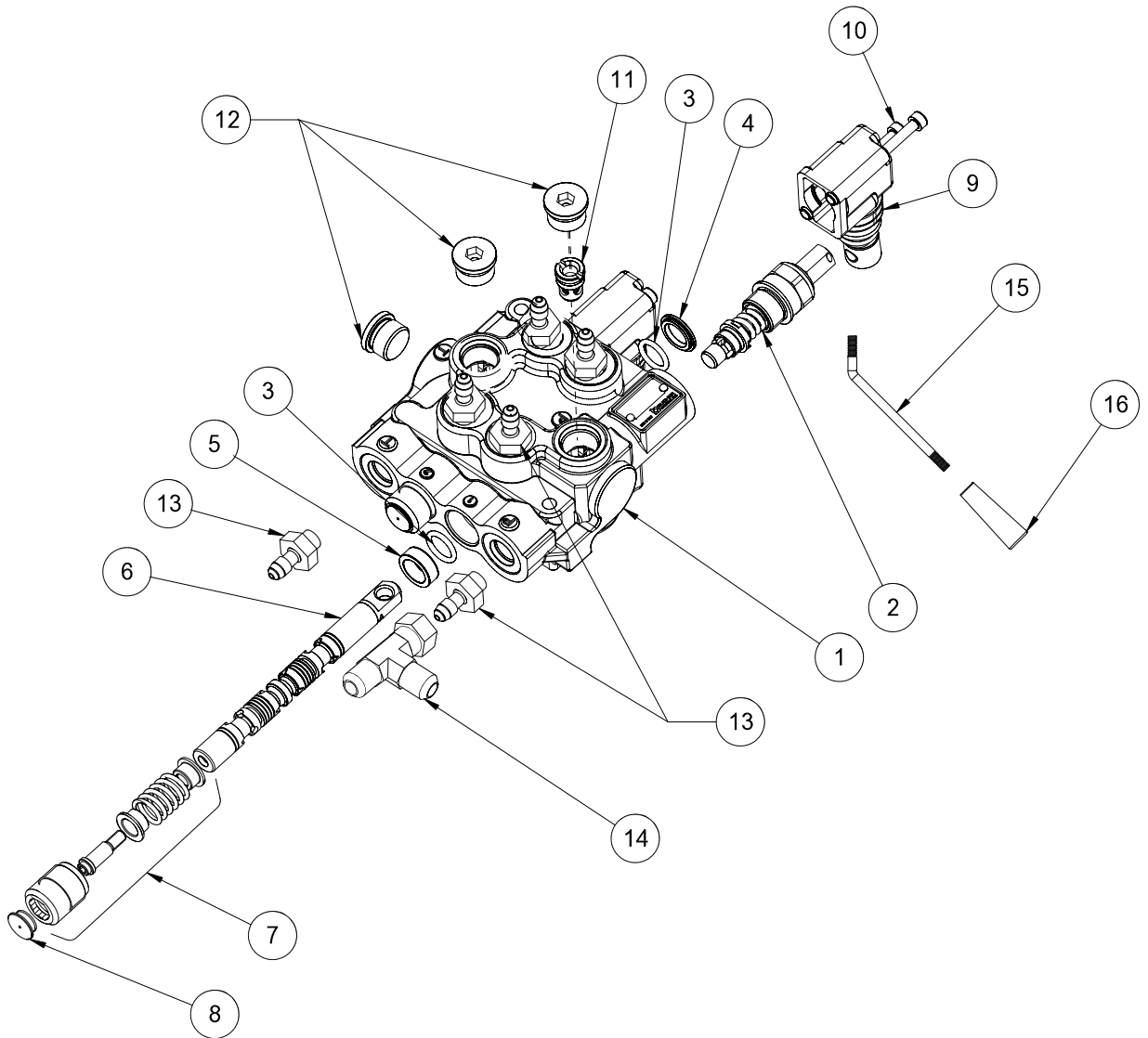

Parts

## 13-729 2-BANK HYDRAULIC VALVE

REF#	PART#	DESCRIPTION	QUANTITY
1*	78-415-01	Body (complete with spacer and check valve)	1
2*	78-415-02	Spool HDM10	1
3*	78-415-03	O-Ring Seal	6
4*	78-415-04	Flanged Washer HDM10	3
5*	78-415-05	Spacer	3
6*	78-415-06	A Type Spool HDS11	3
7*	78-415-11	Positioner	2
8*	78-415-08	Plug	3
9*	78-415-09	Lever Group HDS11	3
10*	78-415-10	Metric Socket Screw M5 x .8 x 45	6
11*	78-415-12	Check Valve Assembly HDM12	1
12*	78-415-13	$\frac{3}{4}$ - 16 SAE 8 Screw Plug	3
13	18-169	Adapter $\frac{1}{4}$ - $\frac{3}{8}$ SAE	6
14	18-190	Tee	1
15	78-418	Bent Handle	2
16		Tapered Knob	2
* 13-729		2 – Bank Hydraulic Valve (includes all * items)	



# 15-301 ORBITROL

Parts

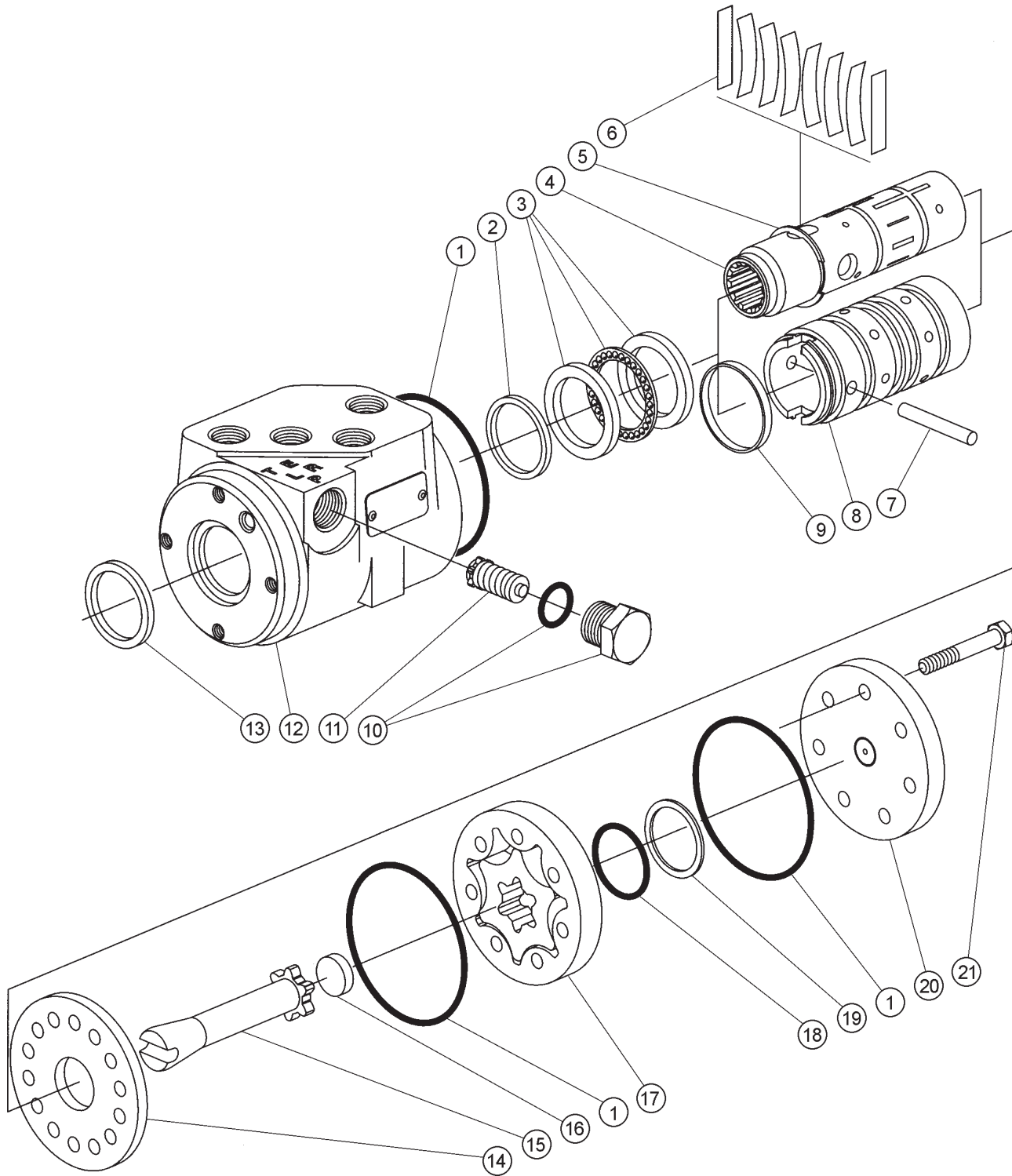

REF#	PART#	DESCRIPTION	QUANTITY
1*		O-Ring Seal	3
2*		Quad Seal	1
3	15-301-14	Bearing Kit	1
		Bearing Race	2
		Bearing	1
4		Spool	1
5	15-301-13	External Retaining Ring	1
6	15-301-15	Spring Centering Kit (Includes Ref# 9)	1
		Spring Spacer	2
		Centering Spring	6
		Spring Retaining Ring	1
7	15-301-08	Pin	1
8		Sleeve	1
9		Retainer	1
10	15-301-11	Plug and O-ring	1
*		O-Ring Seal	1
		Plug	1
11	15-301-12	Relief Valve/Check (1015 psi (70bar))	1
12		Housing	1
13*		Dust Seal	1
14	15-301-06	Wear Plate	1
15	15-301-07	Drive	1
16	15-301-05	Spacer	1
17	15-301-04	Gerotor	1
18*		O-Ring	1
19*		Seal	1
20	15-301-03	End Cap	1
21	15-301-02	Cap Screw	7
*	15-301-01	Seal Kit	

15-301 ORBITROL SPECIFICATIONS

Maximum System Pressure	1015 psi (70bar)
Maximum Back Pressure	150 psi (10bar)
Maximum System Operating Temperature.	200°F (93°C)
Maximum Flow	4 gpm (15 lpm)
Maximum Temperature Differential between Steering Unit and System.	50°F (28°C)
Input Torque Powered	15-25lb/in @ 100psi tank pressure (2-3Nm @ 7bar)
Input Torque Maximum Non-powered	60lb/ft (81Nm)
Rotation Limits	None
Fluid	SAE 10W-40 API Service SG
Check Valve for Manual Steering	Yes
Relief Valve Setting	1015 psi (70bar)
Ports	9/16 - 18 SAE O-Ring 4 Ports
Displacement	61 cu. in/ R (100 cu cm/R)



# 15-315 HYDRAULIC PUMP

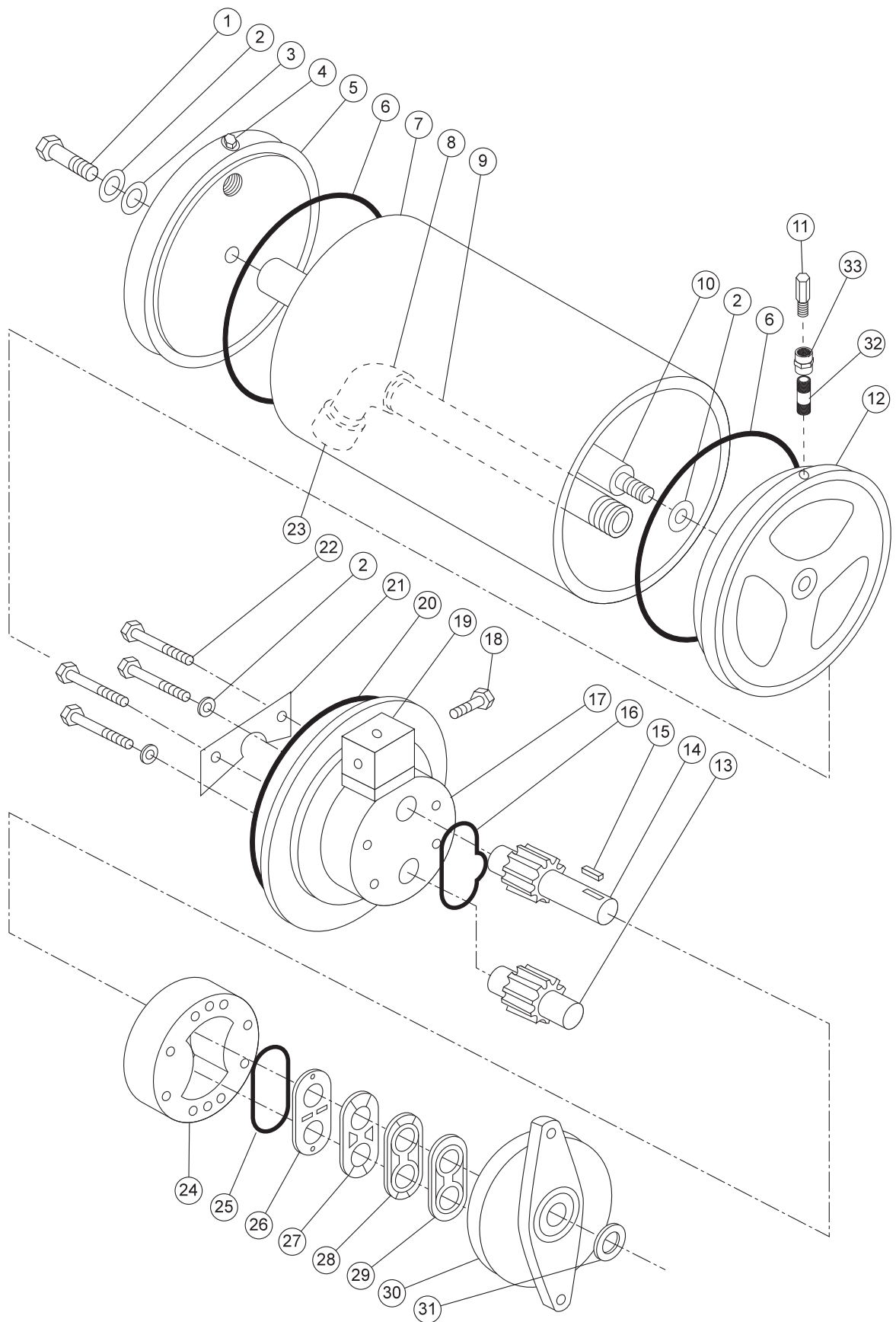

Parts

# 15-315 HYDRAULIC PUMP

REF#	PART#	DESCRIPTION	QUANTITY
1	15-315-18	Cap Screw	1
2	15-315-17	Washer	4
3*		Stato-Seal	1
4	18-060	Pipe Plug $\frac{3}{8}$ NPT	2
5	15-315-10	Tank End	1
6*	15-315-20	O-Ring	2
7	15-315-11	Tube (Tank)	1
8	15-315-13	Elbow	1
9	15-315-12	Nipple	1
10	15-315-15	Spacer Assembly	1
11	27-059	Filler Breather	1
12	15-315-09	Tank End/Tank Pump	1
13	15-315-05	Driven Gear Assembly	1
14	15-315-04	Drive Gear Assembly	1
15	HWK-18-063	Woodruff Key $\frac{1}{8}$ x $\frac{5}{8}$	1
16*		Molded O-Ring	1
17	15-315-07	Back Cover	1
18	15-315-06	Relief Valve	1
19	15-315-16	Sub-Plate (Includes 1-Sub-Plate, 4-Mounting Bolts, 3-O-Rings and 1-Plug)	1
20*	15-315-21	Tank/Pump Gasket	1
21	15-315-08	Baffle	1
22	15-315-19	Cap Screw	4
23	15-315-14	Strainer	1
24	15-315-03	Center Section	1
25*		O-Ring	1
26*		Wear Plate	1
27*		Heat Shield	1
28*		Gasket	1
29*		V-seal	1
30	15-315-02	Front Cover	1
31*	15-315-22	Shaft Seal	1
32	18-287	$\frac{3}{8}$ " Pipe Nipple x 2"	1
33	18-314	$\frac{3}{8}$ " Pipe Coupler	1
*	15-315-01	Repair Kit (For Pump and Tank)	



# BRAKE ASSEMBLY DRAWING

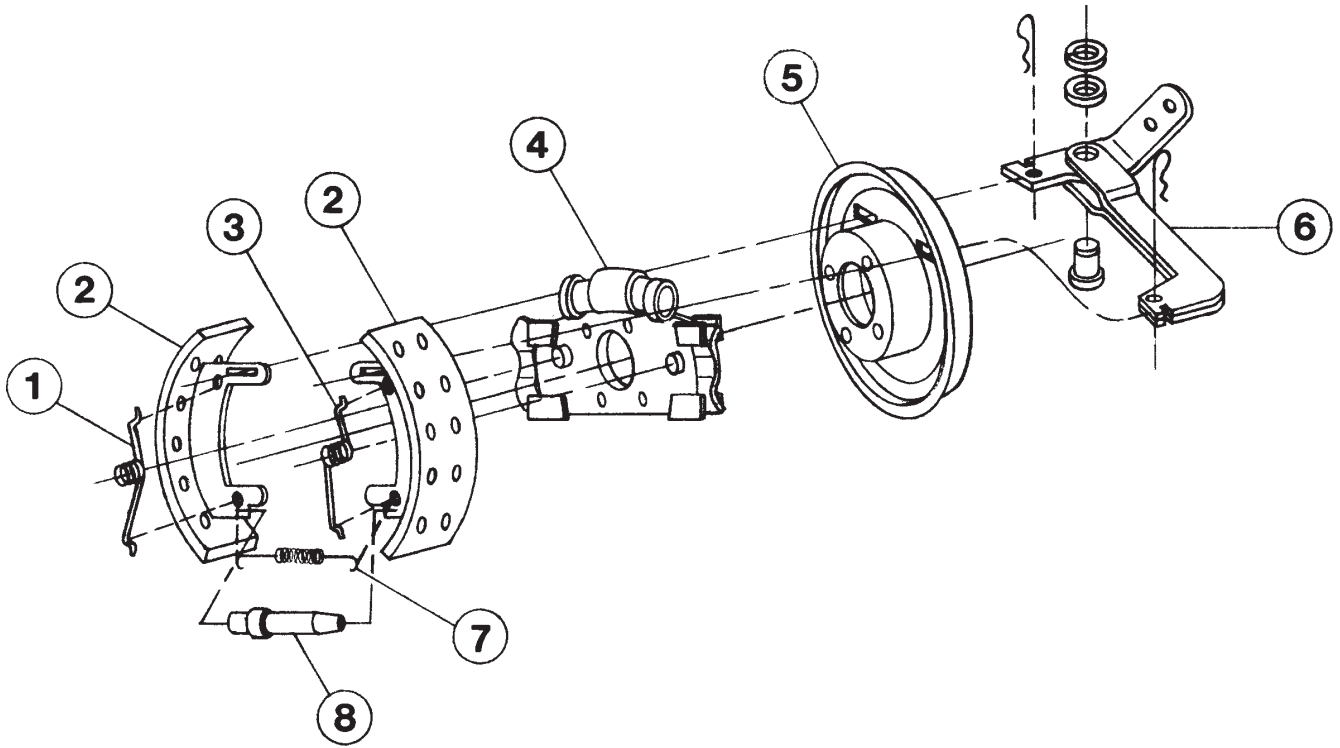

Parts



## BRAKE ASSEMBLY PARTS LIST

REF#	PART#	DESCRIPTION	QUANTITY
1	16-704	Shoe Return Spring (Green)	1
2	16-725	Shoe and Lining Kit	2 sets required
3	16-705	Shoe Return Spring (Red)	1
4	16-723	Spider Torque Kit	1
5	16-709	Dust Shield and Bearing Retainer	1
6	16-713	Brake Lever Kit (Right or Left)	1
7	16-719	Adjusting Spring	1
8	16-720	Adjusting Screw Kit	1
	16-514	Left Brake Assembly (part of 16-037)	1
	16-554	Right Brake Assembly (part of 16-037)	1
	16-559	Brake Drum (part of 16-037)	2
	16-723-01	Cylinder Kit (Includes Boot and Cup)	2 per cylinder

1. For Left brake, assembly with star wheel of adjusting screw (Ref# 8) towards the front of the brake (as shown), opposite for Right brake.
2. Red Spring- Assemble to front of brake on right side assembly, opposite for left.
3. Green Spring - Assemble to rear of brake on right side assembly, opposite for left.
4. Brake actuating lever (Ref# 6) shown for right assembly, reverse for left assembly. Bent arm stays up, double arm switches to forward.



# 52-005 60" MANUAL PLOW

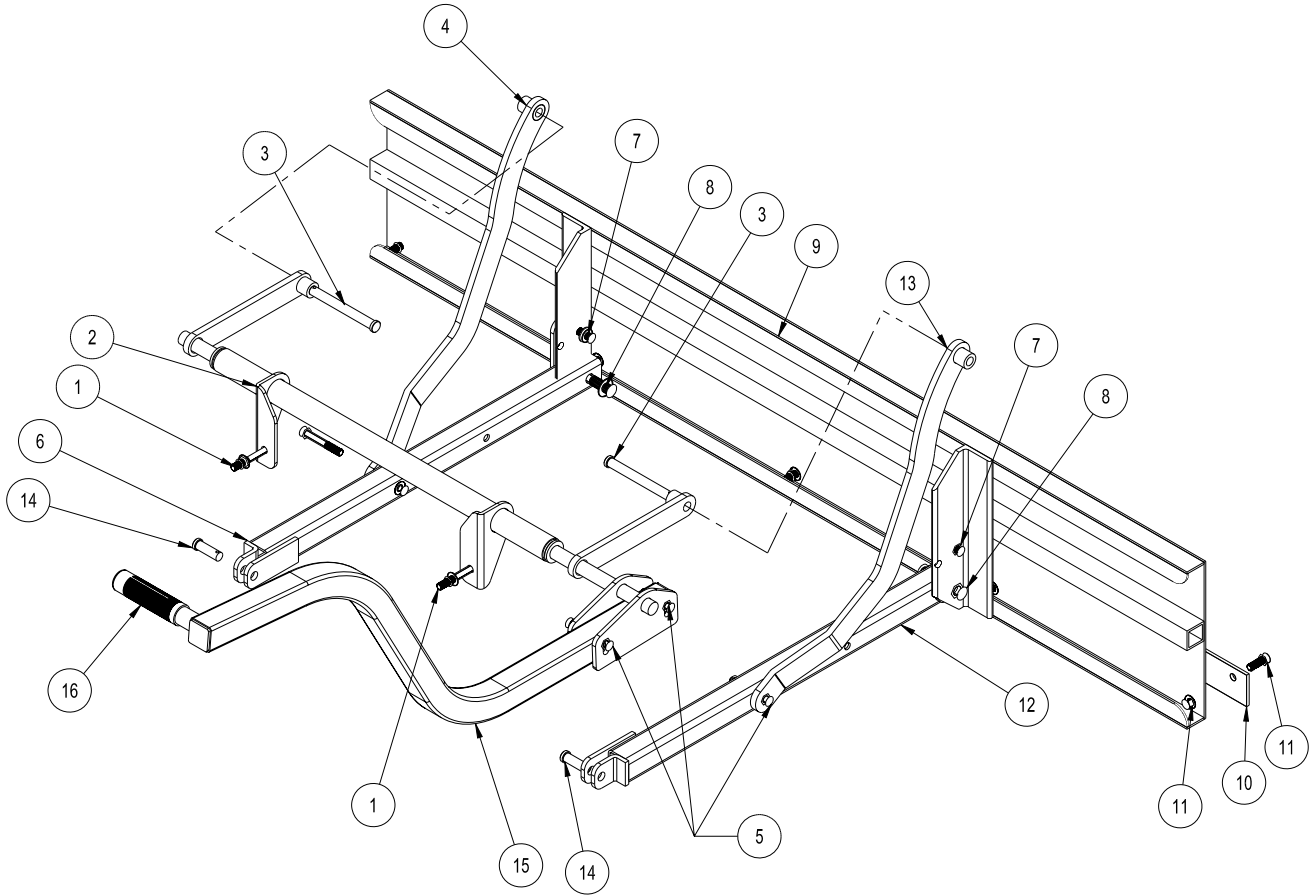

Accessories

REF#	PART#	DESCRIPTION	QUANTITY
1	HB-38-16-225	Bolt, $\frac{3}{8}$ -16 x $2\frac{1}{4}$	2
	HNTL-38-16	Lock Nut, $\frac{3}{8}$ -16	2
2	52-032	Plow Lift	1
	HG-18-180	Grease Fitting, $\frac{1}{8}$ x 180°	1
3	HCP-12-250	Clevis Pin, $\frac{1}{2}$ x $2\frac{1}{2}$	2
	HHP-18	Bridge Pin, $\frac{1}{8}$	2
4	52-040	Left Plow Lift Arm	1
5	HB-38-16-275	Bolt, $\frac{3}{8}$ -16 x $2\frac{3}{4}$	4
	HNTL-38-16	Lock Nut, $\frac{3}{8}$ -16	4
6	27-049	Left Pusher Bar	1
7	HB-38-16-125	Bolt, $\frac{3}{8}$ - 16 x $1\frac{1}{4}$	2
	HW-38	Washer, $\frac{3}{8}$	4
	HNTL-38-16	Lock Nut, $\frac{3}{8}$ - 16	2
8	HB-12-13-300	Bolt, $\frac{1}{2}$ - 13 x 3	2
	HNTL-12-13	Lock Nut, $\frac{1}{2}$ - 13	2
9	35-011	Aluminum 60" Plow Blade	1
10	35-012	Wear Blade	1
11	HB-38-16-100	Bolt, $\frac{3}{8}$ - 16 x 1	5
	HNFL-38-16	Flange Lock Nut, $\frac{3}{8}$ - 16	5
12	27-050	Right Pusher Bar	1
13	52-039	Right Plow Lift Bar	1
14	HCP-12-150	Clevis Pin, $\frac{1}{2}$ x $1\frac{1}{2}$	2
	HHP-18	Bridge Pin, $\frac{1}{8}$	2
15	52-037	Plow Lift Handle	1
	8842-3	Foam Tape, 3"	1
16	15-019	Round Grip	1

## SAND PLOW INSTALLATION

1. Assemble Pusher Bars to Plow using (Ref# 7 and 8) hardware. There is a slot to bolt (Ref# 7) hardware in. Sliding the bolt closest to the blade will result in a shallow cut, whereas using the end of the slot furthest from the blade will result in a deeper cut.
2. Bolt the (Ref# 2) Lift Assembly to the Main Frame below the front of the console using (Ref# 1) hardware .
3. Attach the (Ref# 15) Lift Handle to the lift assembly using (Ref# 14) hardware.
4. Attach the right and left plow lift arms (Ref# 4 and 13) to the lift assembly (Ref# 2) using the (Ref# 3) clevis pins.
5. Slide Plow under machine and connect to machine. Use (Ref# 14) Clevis Pin and Bridge Pin.
6. Lift up the plow and attach the right plow lift Arm (Ref# 13) then do the same with the left.
7. Tighten all hardware and make sure bridge pins are in all clevis pins.
8. We include 3" of foam tape to be placed on the lift handle where it rests on the floorboard when in the down position.



# 52-006 SPRING TINE CULTIVATOR

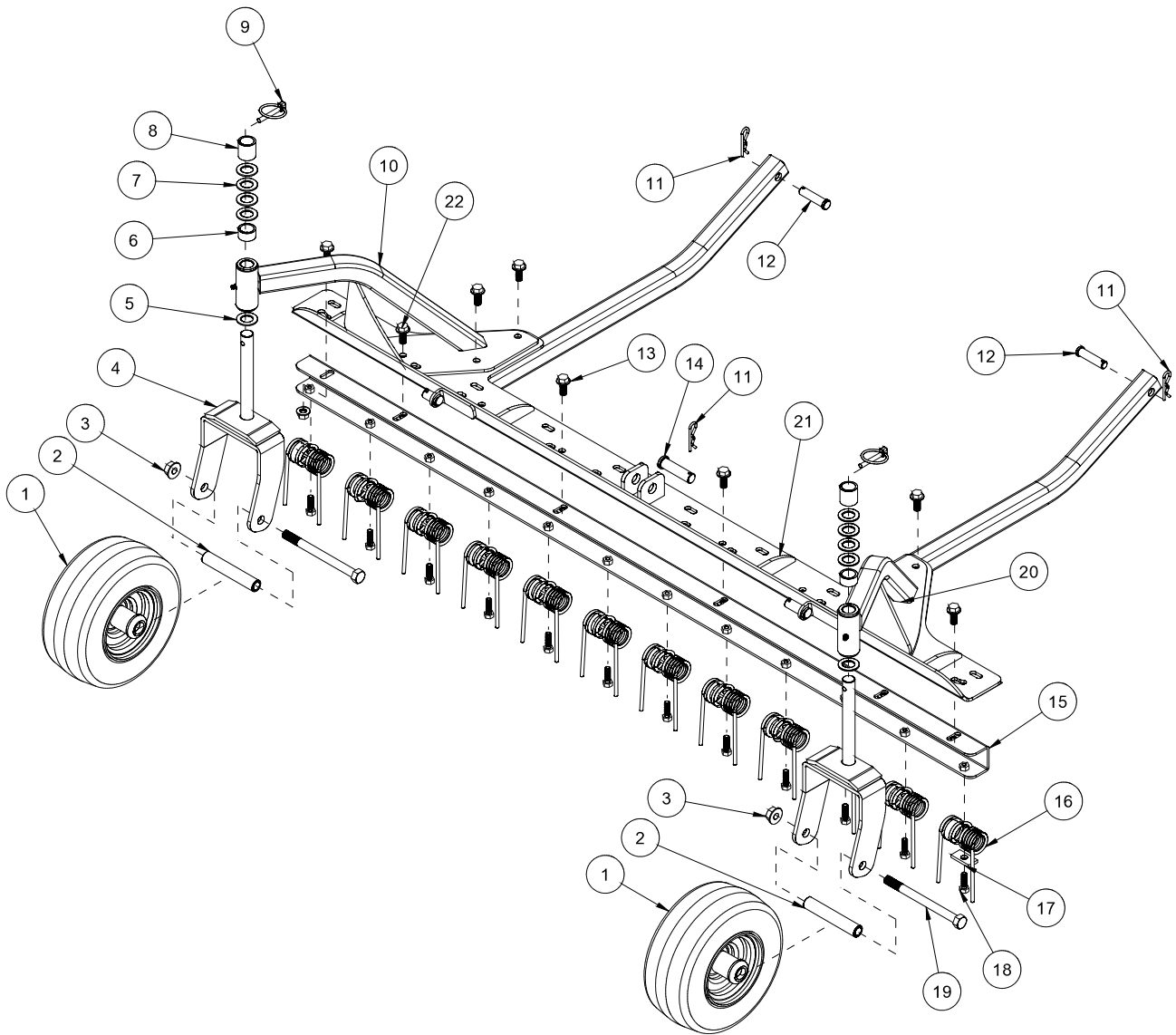

Accessories

## 52-006 SPRING TINE CULTIVATOR

REF#	PART#	DESCRIPTION	QUANTITY
1	42-202	Tire and Wheel	2
2	33-338	Axle Bearing	2
3	HNTL-12-13	Lock Nut, 1/2 -13	2
4	42-204	Castor Fork	2
5	HMB-34-14	Machine Bushing, 3/4 x 14GA	2
6	42-215	Short Spacer	2
7	HMB-34-10	Machine Bushing, 3/4 x 10GA	8
8	42-214	Long Spacer	2
9	42-539	Lynch Pin	2
10	42-288	Left Castor Wheel Bracket	1
11	HHP-18	Bridge Pin, 1/8	3
12	HCP-12-250	Clevis Pin, 1/2 x 2 1/2	2
13	HB-38-16-100	Bolt, 3/8 - 16 x 1	8
	HW-38	Washer, 3/8	8
	HNTL-38-16	Lock Nut, 3/8 - 16	8
14	HCP-58-250	Cotter Pin, 5/8 x 2 1/2	1
15	42-343	Spring Bar	1
16	42-122	Spring	12
17	42-177	Spring Holder	12
18	HB-516-18-100	Bolt, 5/16 -18 x 1	12
	HNTL-516-18	Lock Nut, 5/16 -18	12
19	HB-12-13-600	Bolt, 1/2 - 13 x 6	2
20	42-289	Right Castor Wheel Bracket	1
21	52-109	Center Lift Assembly	1
22	HB-38-16-125	Bolt, 3/8 - 16 x 1 1/2	2
	HNTL-38-16	Lock Nut, 3/8 - 16	2



# 52-007 DUST SUPPRESSION KIT

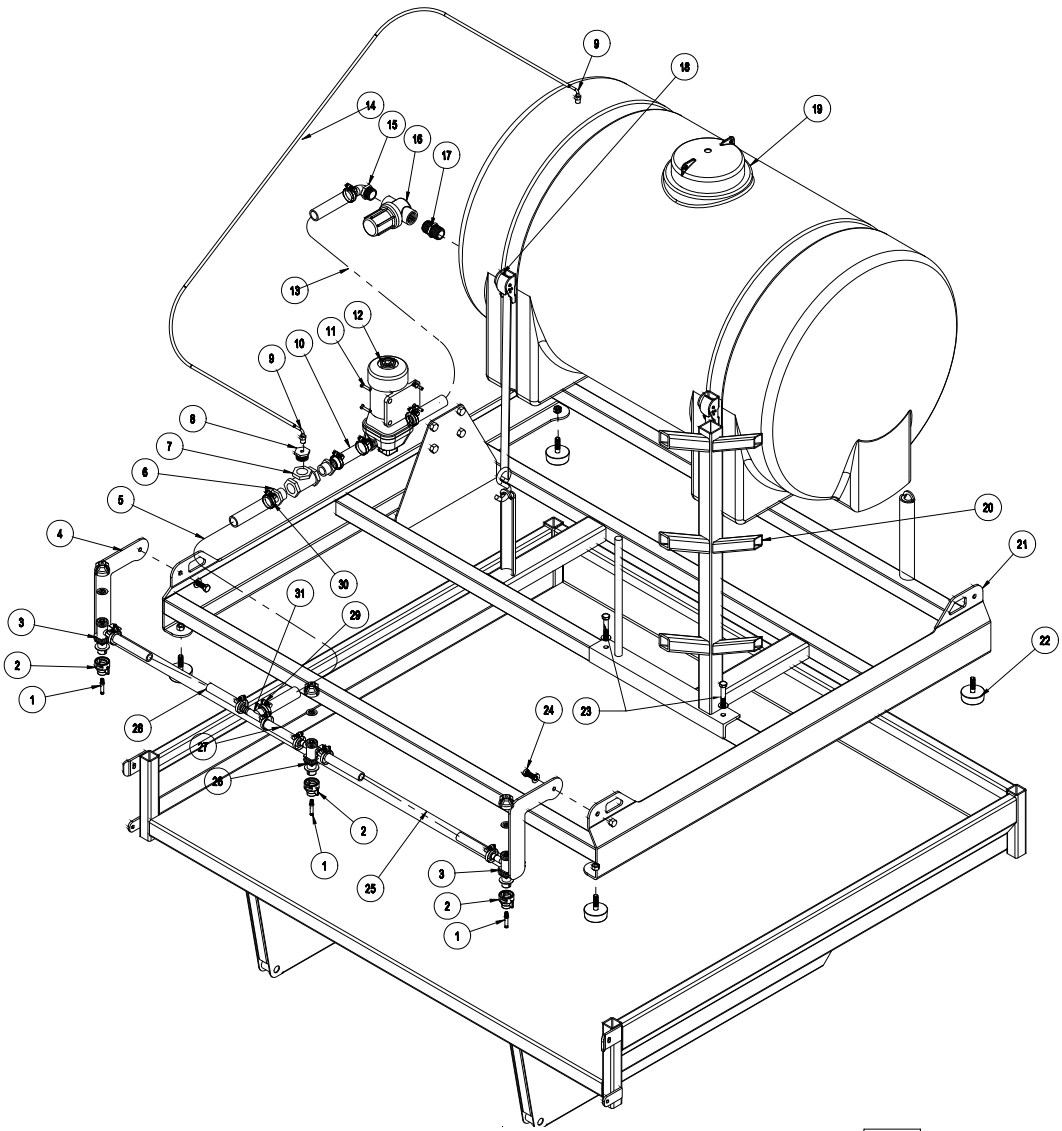

Accessories

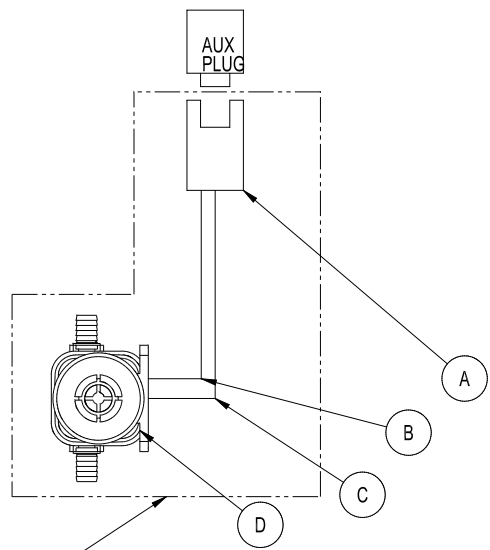

52-007-A  
Dust Suppression

## 52-007 DUST SUPPRESSION KIT

REF#	PART#	DESCRIPTION	QUANTITY
1	52-103	Tip	3
2	33-555	Cap	3
	16-800	Viton Gasket	3
3	16-796	Single Diaphragm Check Valve	2
4	52-082	Spray Bar	1
5	8887-32	3/4" PVC Hose x 32"	1
6	16-154	3/4" Hose Barb Fitting	2
7	16-157	3/4" Tee	1
8	18-414	Drilled Hex Plug	1
9	33-494	Male Elbow	2
10	8887-8.5	3/4" PVC Hose x 8.5	1
11	HSM-10-32-100	Machine Screw, 10 - 32 x 1	4
	HNFL-10-32	Flange Lock Nut, 10 - 32	4
12	52-101	FloJet® Pump	1
13	8887-4.5	3/4" PVC Hose x 4.5	1
14	8954-32	3/16 Clear Hose x 32"	1
15	16-153	Elbow	1
16	52-104	Strainer	1
17	16-158	Close Nipple	1
18	52-102	Cam Buckle	2
19	52-100	65 Gallon Tank	1
20	52-081	Base Tree	1
21	52-080	Accessory Frame	1
22	50-081	Rubber Bumper	4
	HNFL-38-16	Flange Lock Nut, 3/8 - 16	4
23	HB-38-16-250	Bolt, 3/8 - 16 x 2 1/2	2
	HW-38	Washer, 3/8	2
	HNTL-38-16	Lock Nut, 3/8 - 16	2
24	HB-38-16-100	Bolt, 3/8 - 16 x 1	2
	HW-38	Washer, 3/8	2
	HNTL-38-16	Lock Nut, 3/8 - 16	2
25	8888-22	1/2" PVC Hose x 22	1
26	16-797	Double Diaphragm Check Valve	1
27	8888-4	1/2" PVC Hose x 4	1
28	8888-18	1/2" PVC Hose x 18	1
29	18-040	Hose Clamp	7
	9024	Plastic Cover	7
30	18-224	Hose Clamp	6
	9024	Plastic Cover	6
31	52-105	Tee Barb	1
A	9016	Weather Pack	1
	9017	Weather Pack Terminal	2
	9018	Seal	2
B	8850-96	14GA Red Wire	1
C	8849-96	14GA Black Wire	1
	8900-96	Flex Guard Loom	1
D	52-101	FloJet® Pump	1



# 52-008 REAR DRAG

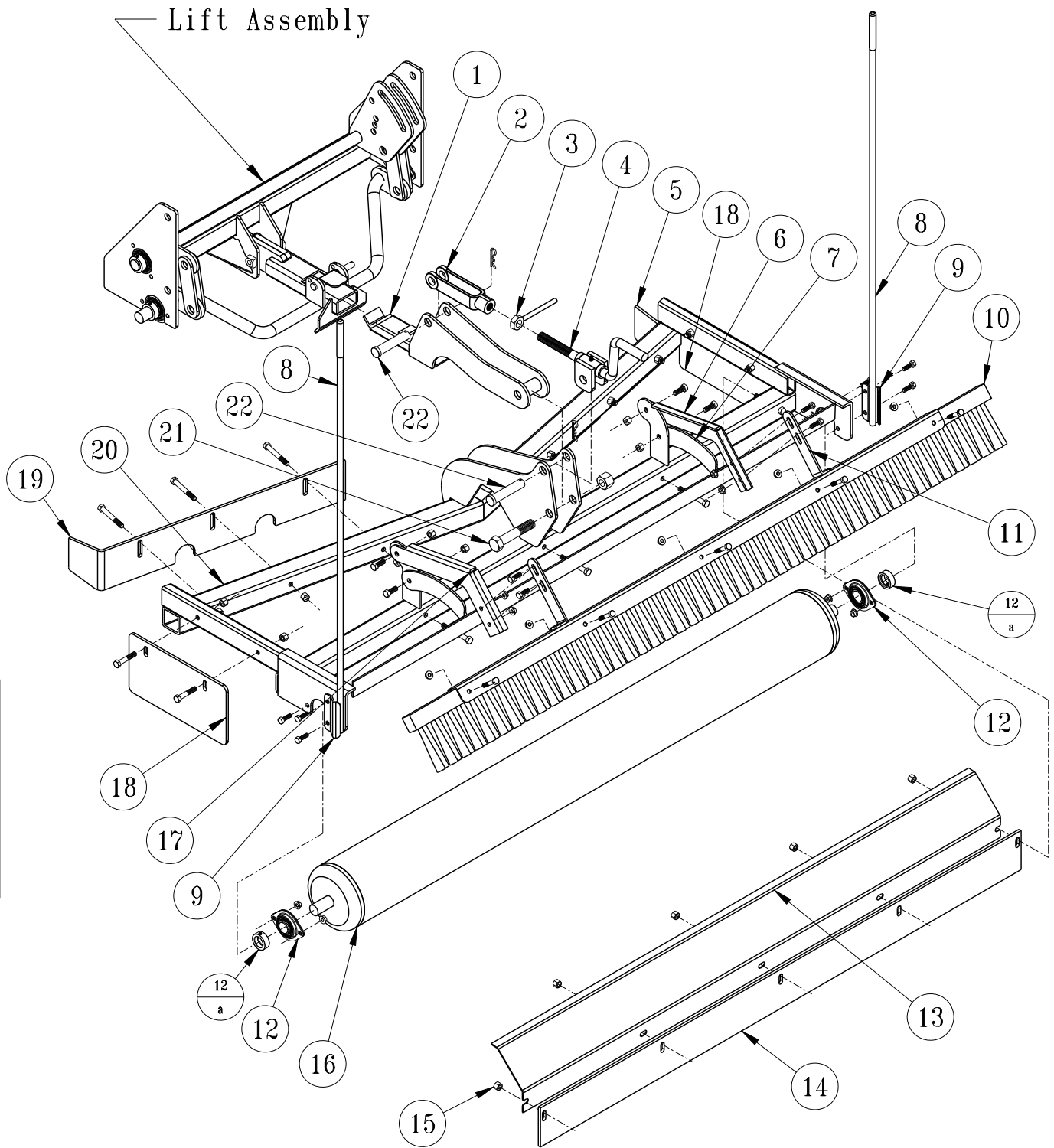

Accessories



REF#	PART #	DESCRIPTION	QUANTITY
1	52-117	Grader Quick Hitch	1
2	42-040	Yoke, $\frac{3}{4}$	1
3	52-115	Adjustment Lock	1
4	52-116	Adjustment Handle Assembly.	1
	52-118	Spacer	2
5	52-092	Grader Blade, RH Front	1
	HB-38-16-300	Bolt, $\frac{3}{8}$ -16 x 3	3
	HNTL-38-16	Lock Nut, $\frac{3}{8}$ -16	3
6	52-098	RH Brush Arm	1
	HB-38-16-100	Bolt, $\frac{3}{8}$ -16 x 1	1
	HNTL-38-16	Lock Nut, $\frac{3}{8}$ -16	1
7	52-111	Roller Scraper	1
	HB-38-16-100	Bolt, $\frac{3}{8}$ -16 x 1	2
	HNTL-38-16	Lock Nut, $\frac{3}{8}$ -16	2
8	52-142	Marker Rod	2
	13-499	Hand Grip	2
9	52-123	Marker Rod Bracket	2
	HB-516-18-125	Bolt, $\frac{5}{16}$ -18 x $1\frac{1}{4}$	4
	HNFL-516-18	Flange Lock Nut, $\frac{5}{16}$ -18	4
10	76-455	Nylon Brush	1
	HB-516-18-175	Bolt, $\frac{5}{16}$ -18 x $1\frac{3}{4}$	5
	HNFL-516-18	Flange Lock Nut, $\frac{5}{16}$ -18	5
11	52-083	Brush Mount	1
	HB-516-18-100	Bolt, $\frac{5}{16}$ -18 x 1	4
	HNFL-516-18	Flange Lock Nut, $\frac{5}{16}$ -18	4
12	13-391	Stamped Bearing, 1"	2
12a		Bearing Collar, 1"	2
	HB-516-18-100	Bolt, $\frac{5}{16}$ -18 x 1	2
	HNFL-516-18	Flange Lock Nut, $\frac{5}{16}$ -18	2
13	52-096	Grader Guard	1
14	52-094	Rear Grader Blade	1
15	HB-38-16-300	Bolt, $\frac{3}{8}$ -16 x 3	5
	HNTL-38-16	Lock Nut, $\frac{3}{8}$ -16	5
16	52-110	AFC Roller	1
17	52-099	LH Brush Arm	1
	HB-38-16-100	Bolt, $\frac{3}{8}$ -16 x 1	1
	HNTL-38-16	Lock Nut, $\frac{3}{8}$ -16	1
18	52-095	Side Grader Plate	2
19	52-093	Grader Blade, LH Front	1
	HB-38-16-300	Bolt $\frac{3}{8}$ -16 x 3	3
	HNTL-38-16	Lock Nut $\frac{3}{8}$ -16	3
20	52-090	Grader Box	1
21	HB-34-10-400	Bolt $\frac{3}{4}$ -10 x 4	1
	HNTL-34-10	Lock Nut $\frac{3}{4}$ -10	1
22	HCP-34-350	Clevis Pin, $\frac{3}{4}$ x $3\frac{1}{2}$	2
	HHP-18	Bridge Pin, $\frac{1}{8}$	2



# 52-010 STRAIGHT STEEL BLADE SCARIFIER

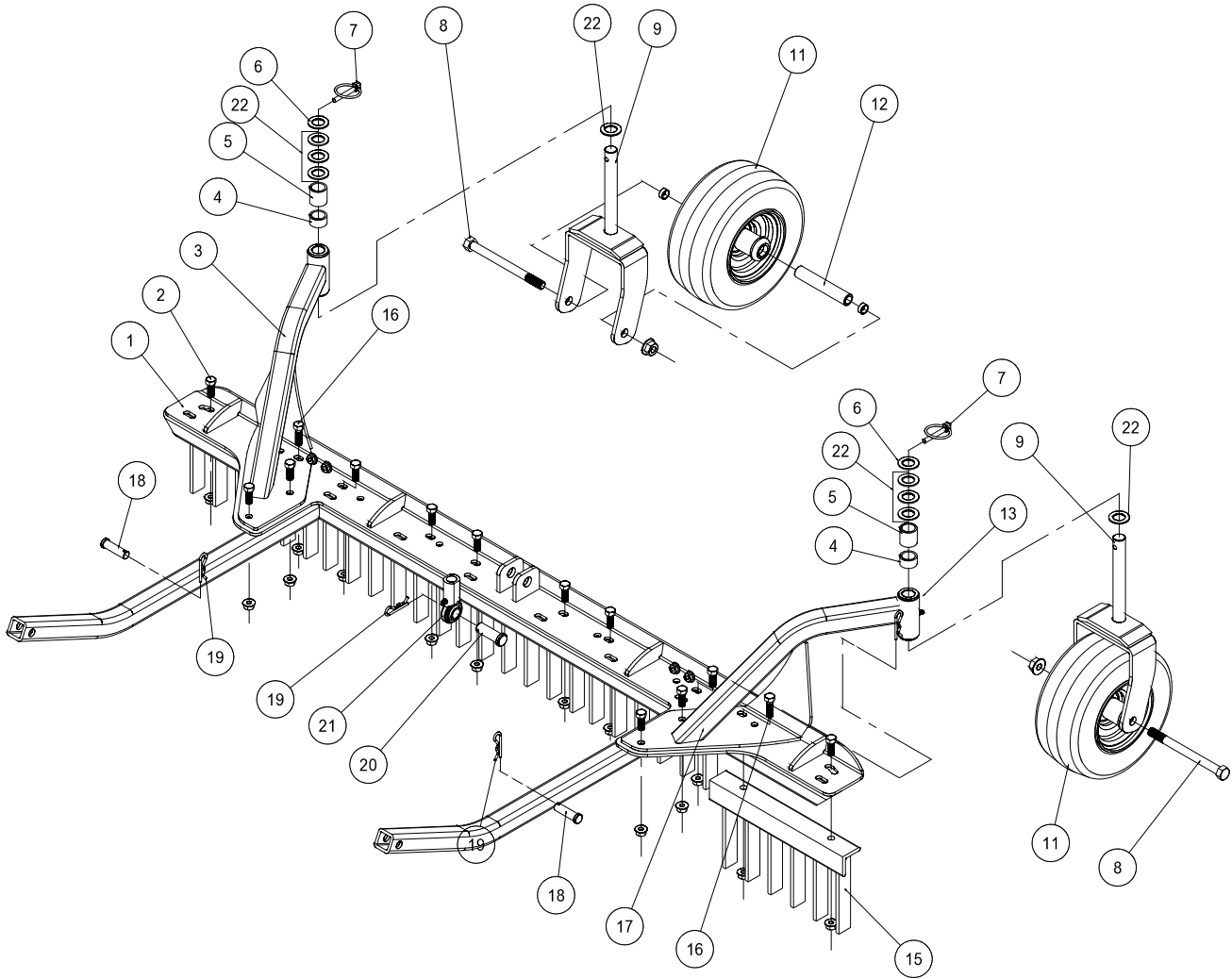

Accessories

## 52-010 STRAIGHT STEEL BLADE SCARIFIER

REF#	PART#	DESCRIPTION	QUANTITY
1	52-109	Attachment Lift Assembly	1
2	HB-38-16-100	Bolt, $\frac{3}{8}$ - 16 x 1	12
	HNTL-38-16	Lock Nut, $\frac{3}{8}$ - 16	12
3	42-288	Left Castor Wheel Bracket	1
	10-025	Bushing (part of 42-288)	2
4	42-215	Short Spacer	2
5	42-214	Long Spacer	2
6	HMB-34-14	Machine Bushing, $\frac{3}{4}$ x 14GA	2
7	42-539	Lynch Pin, $\frac{5}{16}$	2
8	HB-12-13-600	Bolt, $\frac{1}{2}$ -13 x 6	2
	HNTL-12-13	Lock Nut, $\frac{1}{2}$ - 13	2
9	42-204	Castor Fork	2
11	42-202	Tire and Wheel	2
12	33-338	Axle Bearing	2
13	HG-14-28-180	Grease Fitting, $\frac{1}{4}$ - 28 x 180° (part of 42-288 and 42-289)	2
15	42-241	Tine Segment	5
16	HB-38-16-125	Bolt, $\frac{3}{8}$ - 16 x 1 $\frac{1}{4}$	2
	HNTL-38-16	Lock Nut, $\frac{3}{8}$ - 16	2
17	42-289	Right Castor Wheel Bracket	1
	10-025	Bushing (part of 42-289)	2
18	HCP-12-250	Clevis Pin, $\frac{1}{2}$ x 1 $\frac{3}{4}$	2
19	HHP-18	Bridge Pin, $\frac{1}{8}$	3
20	HCP-58-250	Clevis Pin, $\frac{5}{8}$ x 2 $\frac{1}{2}$	1
21	18-154	Rod End (part of machine)	1
22	HMB-34-10	Machine Bushing, $\frac{3}{4}$ x 10GA	8

# 52-012 FLEXACTION FIELD FINISHER

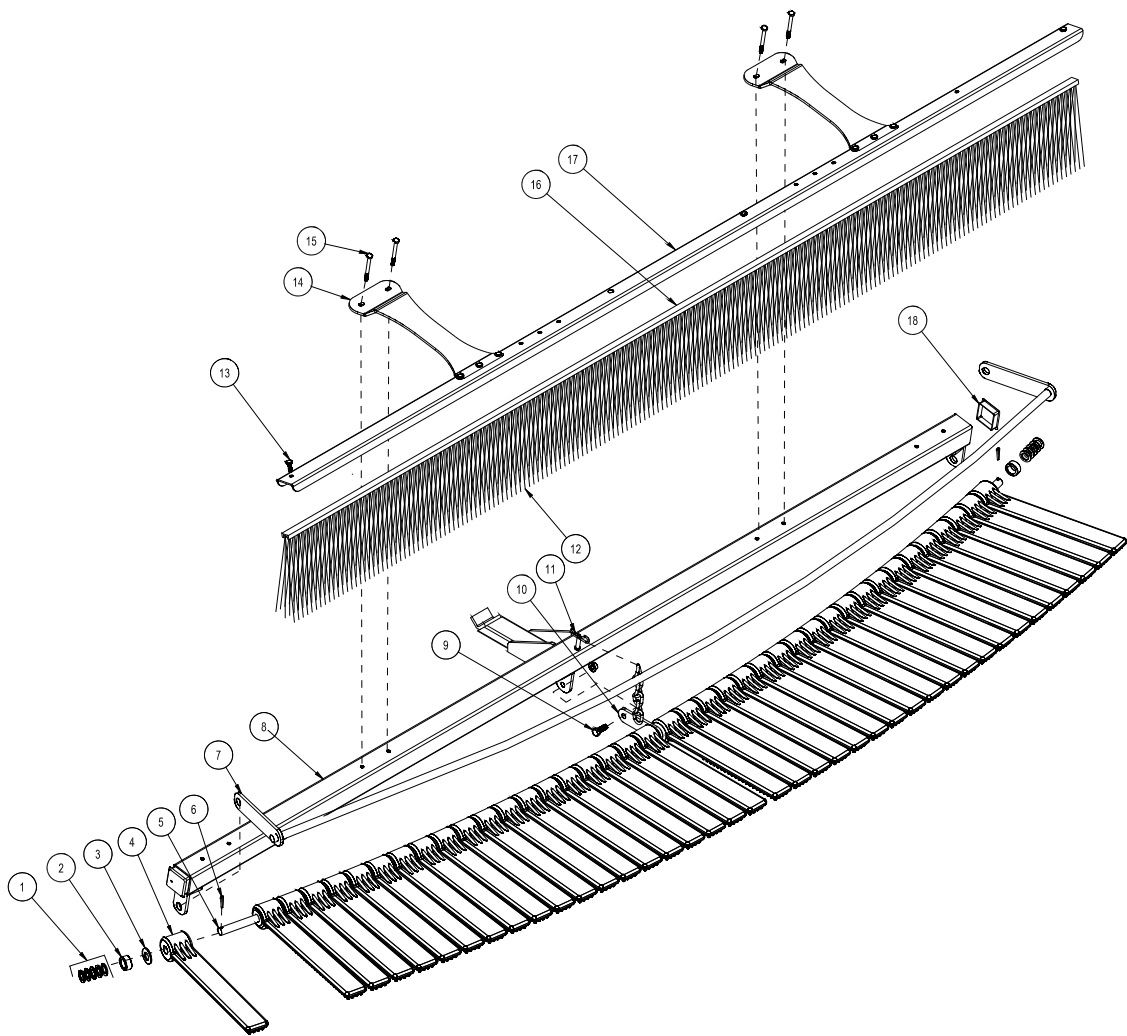

Accessories

## 52-012 FLEXACTION FIELD FINISHER

REF#	PART #	DESCRIPTION	QUANTITY
1	HMB-58-14	Machine Bushing, $\frac{5}{8}$ x 14GA	8
2	11-040	Spacer	2
3	HW-58	Washer, $\frac{5}{8}$	40
4	26-041	Flail	40
5	52-128	Flail Mounting Bar	1
6	HP-18-100	Cotter Pin, $\frac{1}{8}$ x 1	2
7	52-129	Leveler Bar	1
8	52-130	Finisher Frame	1
9	HB-38-16-100	Bolt, $\frac{3}{8}$ - 16 x 1	1
	HNCL-38-16	Center Lock Nut, $\frac{3}{8}$ -1 x 6	1
10	26-048	Flail Bar Strap	1
11	HHP-18	Bridge Pin, $\frac{1}{8}$	1
12	13-738	Brush	1
13	HB-14-20-075	Bolt, $\frac{1}{4}$ - 20 x $\frac{3}{4}$	10
	HNFL-14-20	Flange Lock Nut, $\frac{1}{4}$ - 20	10
14	13-681	Mounting Bracket	2
15	HB-14-20-250	Bolt, $\frac{1}{4}$ - 20 x $2\frac{1}{2}$	4
	HNFL-14-20	Flange Lock Nut, $\frac{1}{4}$ - 20	4
16	13-739	Brush Track	1
17	13-737	Brush Channel	1
18	18-297	Cap Plug	2



# 72" COCO MAT FINISHER

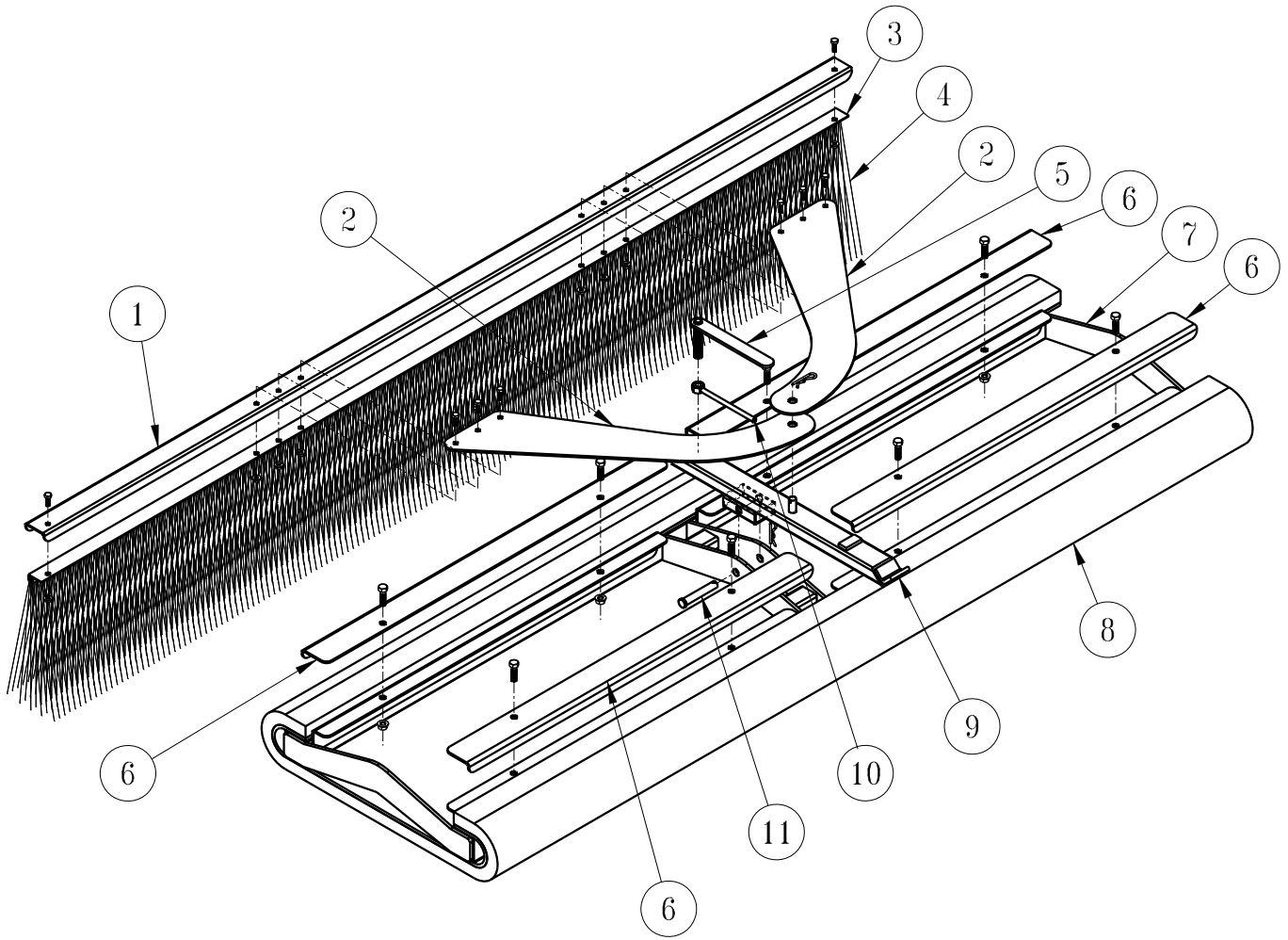

Accessories

REF#	PART#	DESCRIPTION	QUANTITY
1	13-688	Brush Channel	1
	HB-14-20-075	Hex Bolt, $\frac{1}{4}$ - 20 x $\frac{3}{4}$	2
	HNFL-14-20	Flange Lock Nut, $\frac{1}{4}$ - 20	2
2	43-168	Brush Mount Arm	2
	HB-14-20-075	Hex Bolt, $\frac{1}{4}$ - 20 x $\frac{3}{4}$	6
	HNFL-14-20	Flange Lock Nut, $\frac{1}{4}$ - 20	6
3	13-683	Brush Track	1
4	13-682	Brush, 77 x 11	1
5	43-164	Adjustment Handle	1
6	43-166	Mat Clamp	4
	HB-38-16-125	Hex Bolt, $\frac{3}{8}$ - 16 x $1\frac{1}{4}$	8
	HNFL-38-16	Flange Lock Nut, $\frac{3}{8}$ - 16 x $1\frac{1}{4}$	8
7	43-165	Frame	1
8	43-167	CoCo Mat, 27 x 72	1
9	43-162	Draw Bar	1
	HHP-18	Bridge Pin, $\frac{1}{8}$	1
10	43-163	Lock Handle	1
11	HCP-12-300	Clevis Pin, $\frac{1}{2}$ x 3	1
	HHP-18	Bridge Pin, $\frac{1}{8}$	1



# NOTES

Reference





## DECAL LIST

***This is a list of decals located on the Sport Truck. Part number, description and location will help in reordering decals.***

16-088	Decal, Moving Parts	1	Belt Guard
25-277	Decal, Battery Warning	1	Left Side Box
25-279	Decal, Safety Warning	1	Right Main Frame
25-286	Decal, Pinch Point	4	Left and Right Console, Left and Right Side Main Frame
25-298	Decal, Warning - Hot	1	Inlet Tube
25-307	Decal, Refuel	1	Left Console
25-354	Decal, Tire 5 PSI	2	Front Tires
25-358	Decal, Smithco	1	Rear tailgate
25-375	Decal, DBA	1	Left Console
27-077	Decal, Smithco Domed	1	Steering Wheel
27-093	Decal, Hydraulic Oil	1	Hydraulic Power Unit
34-147	Decal, Smithco Star	1	Front Nose Cone
52-021	Decal, Dashboard	1	Dashboard
52-050	Decal, Console Shift	1	Right Console
52-051	Decal, Console Lift lower	1	Left Console
52-122	Decal Sport Truck	2	Box Sides

## QUICK REFERENCE REPLACEMENT PARTS

### REPLACEMENT FILTERS

15-165-01	Air Filter Element with Pre-Cleaner	Briggs & Stratton # 5050
50-403	Fuel Filter	
13-531	Engine Oil Filter	Briggs & Stratton # 492932
42-076-03	Air Filter Element Fender Mounted	

### SEAL KITS

75-714	Hydraulic Cylinder
14-254	Seal Kit
15-301	Orbitrol
15-301-01	Seal Kit
15-315	Hydraulic Pump
15-315-01	Repair Kit (For Pump and Tank)

### FLUIDS

Engine Oil	Refer to Engine Manual
Hydraulic Fluid	SAE 10W-40 API Service SJ or higher Motor Oil

### BELTS

52-046	Drive belt
16-601	Belt

# The Smithco Commercial Products Two-Year Limited Warranty

Smithco, Inc. (Smithco) warrants your 2007 or newer Smithco Commercial Product ("Product") purchased after January 1, 2007, to be free from defects in materials or workmanship for the period of time listed below. Where a warrantable condition exists, Smithco will repair the Product at no cost to you including diagnosis, labor (at the Smithco standard labor rate, subject to the Smithco flat rate schedule), and parts.

## Warranty Duration is:

- (1) Two years, 1500 operational hours\* from the date of delivery to the original purchaser or three years from the date of original manufacturer of the product, whichever occurs first. (\*Products equipped with hour meter).
- (2) Products used in rental situations are covered for 90 days from date of delivery to original user/ renter.

## Owner Responsibilities:

As the Product owner, you are responsible for required maintenance and adjustments stated in your Owner's Manual. Failure to perform required maintenance and adjustments can be grounds for disallowing a warranty claim. **You are particularly responsible to train all present and future operators of this product on the safe operation of this product at your location.**

## Instructions for Obtaining Warranty Service:

You are responsible for notifying the Authorized Smithco Products Distributor from whom you purchased the Product as soon as you believe a warrantable condition exists and not later than 30 days from discovery of the condition.

If you need help locating an Authorized Smithco Distributor, or if you have questions regarding your warranty rights or responsibilities, you may contact us at:

Smithco Product Support Department  
200 W Poplar PO Box 487  
Cameron, Wisconsin 54822

Telephone: 1-800-891-9435

E-Mail: [ProductSupport@smithco.com](mailto:ProductSupport@smithco.com)

## Maintenance Parts:

Parts scheduled for replacement as required maintenance ("Maintenance Parts"), are warranted for the period of time up to the scheduled replacement time for that part.

### Items/Conditions Not Covered:



Not all product failures or malfunctions that occur during the warranty period are defects in materials or workmanship. The items/conditions listed below are not covered by this warranty:



Product failures which result from the use of non-Smithco replacement parts, or from installation and use of add-on, modified, or unapproved accessories are not covered.



Product failures which result from failure to perform required maintenance and/or adjustments are not covered.



Product failures that result from operating the Product in an abusive, negligent or reckless manner are not covered.



This warranty does not apply to parts subject to consumption through use, unless found to be defective. Examples of parts which are consumed, or used up, during normal Product operation include, but are not limited to: blades, tines, teeth, scarifiers, rakes, plates, wear plates, castor wheels, tires, batteries, filters, belts, nozzles, etc.



This warranty does not apply to failures caused by outside influence. Items considered to be outside influence include, but are not limited to, weather, storage practices, contamination, use of unapproved coolants, lubricants, additives, or chemicals, etc.



This warranty does not apply to normal “wear and tear” items. Normal “Wear and Tear” includes, but is not limited to, damage to seats due to wear or abrasion, worn painted surfaces, scratched decals or windows, etc.



Smithco may require the return of failed parts or components in order to determine the validity of any warranty claim.



Smithco will not be obligated to replace components of other manufacturers if inspection by the original component manufacturer indicates that failure was due to normal wear and tear, expected consumption through use or improper care or service.

### **Other Legal Disclaimers:**

The above remedy for product defects through repair or replacement by an authorized Smithco distributor or dealer is the purchaser’s sole remedy for any defect. This warranty gives you specific legal rights, and you may also have other rights which vary from state to state.

**THERE ARE NO OTHER EXPRESS WARRANTIES OTHER THAN THOSE SET FORTH ABOVE. ALL IMPLIED WARRANTIES OF MERCHANTABILITY AND FITNESS FOR USE ARE LIMITED TO THE DURATION OF THE LIMITED WARRANTIES CONTAINED HEREIN.**

Some states may not allow limitations on how long an implied warranty lasts, so the above limitation may not apply to you.

**THE SMITHCO COMPANY IS NOT LIABLE FOR INDIRECT, INCIDENTAL OR CONSEQUENTIAL DAMAGES IN CONNECTION WITH THE USE OF THE PRODUCT, INCLUDING ANY COST OR EXPENSE OF PROVIDING A SUBSTITUTE PRODUCT OR SERVICE DURING PERIODS OF MALFUNCTION OR NON-USE.**

Some states may not allow the exclusion of indirect, incidental or consequential damages, so the above exclusion may not apply to you.

**Smithco neither assumes, nor authorizes any person to assume for it, any other liability in connection with the sale or use of this product.**

**SMITHCO, INC.**

**Wayne, PA 19087**

