

Parts & Service



Spray Star 3180  
Model 30-000

SN: 300G001

January 2008

Revised June 2008

**Product Support:**

**Hwy 55 & Poplar Ave; Cameron WI 54822**

**1-800-891-9435    [productsupport@smithco.com](mailto:productsupport@smithco.com)**

# CONTENTS

Introduction

## **Introduction ..... 1-3**

Introduction .....	1
General Safe Practices .....	2
Specifications .....	3
Optional Spray Equipment .....	3

Service

## **Service ..... 4-11**

Maintenance .....	4-6
Wheel Creep .....	6
Adjustments .....	7
Service Chart .....	8
End User's Service Chart .....	9
Storage .....	10-11

Diagrams

## **Diagrams ..... 12-15**

Wiring Diagram .....	12-13
Hydraulic Diagram .....	14-15

Parts

## **Parts ..... 16-49**

Body & Frame .....	16-17
Nose Cone .....	18-21
Front Axle .....	22-23
Oil Tank and Fuel Tank .....	24-25
Seat Panel .....	26-29
Engine and Pumps .....	30-33
Cooler and Exhaust .....	34-35
Spray Tank .....	36-37
Turbo Quad Agitator .....	38-39
15-301 Orbitor .....	40-41
16-998 Hypro® Pump .....	42-43
30-102 Hydrostatic Pump .....	44-47
30-101 Eaton Motor .....	48-49

Accessories

## **Accessories ..... 50-99**

Plumbing 3182 System (Raven 440) .....	50-51
Plumbing 3182 System (Raven 203) .....	52-53
Controls 3182 System (Raven 440) .....	54-55
COntrols 3184 System (raven 203) .....	54-55
16-524 Motorized Control Valve .....	56-57
15-743 Manifold Ball valve .....	56-57
30-003 20' Terrain Following Boom .....	58-63
17-503 20' Spray BOom .....	64-67
Nozzle Assembly .....	68-69
Turbo TurfJet Tips .....	70
XR TEEJET Tips .....	71
30-010 Electric Hose Reel .....	72-75
30-009 Hose Reel .....	76-77
Hose Reel Installation .....	78-79
Hose Reel Adjustments .....	79
30-004 Foam Marker Installation .....	80-87
15-505 Motor Sub Assembly .....	88-89
15-511 Foam Nozzle Sub Assembly .....	90-91
30-006 Fresh Water Tank .....	92-93
14-515 Water Meter Kit (Gallons) .....	94-95
15-618 Water Meter Kit (Liters) .....	94-95
30-007 Chemical Cleanload System .....	96-99

Reference

## **Reference ..... 101-102**

Decal List .....	101
Quick Reference Replacement Parts .....	102
Warranty .....	

Thank you for purchasing a **Smithco** product.

Read this manual and all other manuals pertaining to the Spray Star 3180 carefully as they have safety, operating, assembly and maintenance instructions. Failure to do so could result in personal injury or equipment damage.

Keep manuals in a safe place after operator and maintenance personnel have read them. Right and left sides are from the operator's seat, facing forward.

All **Smithco** machines have a Serial Number and Model Number. Both numbers are needed when ordering parts. The serial number plate on the Spray Star 3180 is located on the left main frame, by front bumper. Refer to engine manual for placement of engine serial number.

For easy access record your Serial and Model numbers here.

<b>SMITHCO</b>		DATE OF MFG.
WAYNE, PENNSYLVANIA 19087 USA 610-688-4009 Fax 610-688-6069		<input type="text"/>
SERIAL NO.	<input type="text"/>	kW/hp <input type="text"/>
MODEL NO.	<input type="text"/>	kg/lb <input type="text"/>



Information needed when ordering replacement parts:

1. Model Number of machine
2. Serial Number of machine
3. Name and Part Number of part
4. Quantity of parts

## SAFE PRACTICES

1. It is your responsibility to read this manual and all publications associated with this machine.
2. Never allow anyone to operate or service the machine or its optional equipment without proper training and instructions. Never allow minors to operate any equipment.
3. Learn the proper use of the machine, the location and purpose of all the controls and gauges before you operate the equipment. Working with unfamiliar equipment can lead to accidents.
4. Wear all the necessary protective clothing and personal safety devices to protect your head, eyes, ears, hands and feet. Operate the machine only in daylight or in good artificial light.
5. Inspect the area where the equipment will be used. Pick up all debris you can find before operating. Beware of overhead obstructions and underground obstacles. Stay alert for hidden hazards.
6. Never operate equipment that is not in perfect working order or without decals, guards, shields, or other protective devices in place.
7. Never disconnect or bypass any switch.
8. Carbon monoxide in the exhaust fumes can be fatal when inhaled, never operate a machine without proper ventilation.
9. Fuel is highly flammable, handle with care.
10. Keep engine clean. Allow the engine to cool before storing and always remove the ignition key.
11. Disengage all drives and set park brake before starting the engine.
12. Never use your hands to search for oil leaks. Hydraulic fluid under pressure can penetrate the skin and cause serious injury.
13. This machine demands your attention. To prevent loss of control or tipping of the vehicle:
  - A. Use extra caution in backing up the vehicle. Ensure area is clear.
  - B. Do not stop or start suddenly on any slope.
  - C. Reduce speed on slopes and in sharp turns. Use caution when changing directions on slopes.
  - D. Stay alert for holes in the terrain and other hidden hazards.
14. Before leaving operator's position:
  - A. Disengage all drives.
  - B. Set park brake.
  - C. Shut engine off and remove the ignition key.
  - D. If engine has to run to perform any maintenance keep hands, feet, clothing and all other parts of body away from moving parts.
15. Keep hands, feet and clothing away from moving parts. Wait for all movement to stop before you clean, adjust or service the machine.
16. Keep the area of operation clear of all bystanders.
17. Never carry passengers.
18. Stop engine before making repairs/adjustments or checking/adding oil to the crankcase.
19. Use parts and materials supplied by **Smithco** only. Do not modify any function or part.
20. Use caution when booms are down as they extend out beyond the center line of the machine.
21. The tank is a confined space, take precaution.

***These machines are intended for professional maintenance on golf courses, sports turf, and any other area maintained turf and related trails, paths and lots. No guaranty as to the suitability for any task is expressed or implied.***



## SPECIFICATIONS SPRAY STAR 3180

### WEIGHTS AND DIMENSIONS

Length	128" (325 cm)
Width	72" (183 cm)
Height w/ ROPS	84" (213 cm)
Height w/ Booms Folded	136" (345 cm)
Wheel Base	68" (173 cm)
Weight Empty	2340 lbs (1061 kg)
Weight Full	4950 lbs (2245 kg)

### SOUND LEVEL (DBA)

At ear level	98 dBA
--------------	--------

### ENGINE

Make	Kubota
Model#	V1505
Code / Spec#	1G994-0000
Horsepower	35.5 hp (26.6 kW)
Fuel (EMISSIONS)	No.1-D or No. 2-D, S500: Low Sulfur Diesel (LSD) less than 500 ppm or 0.05 wt. % No1-D or No.2-D, S15: Ultra Low Sulfur Diesel (ULSD) less than 15 ppm or 0.0015 wt. %
Cooling System	Liquid Cooled
Lubrication System	Full Pressure
Alternator	40 Amp

### WHEELS & TIRE

Front:	Two 20 x 11.00 x 10 Turf; 20 psi (1.4 bar)
Rear:	Two 29 x 14.00 x 15 Multi-Trac; 30 psi (2.0 bar)

### SPEED

Infinitely Variable	0-10 m.p.h. (0-18 kph)
---------------------	------------------------

### BATTERY

	Automotive type 24F - 12 volt
BCI Group	Size 24
Cold Cranking Amps	900 minimum
Ground Terminal Polarity	Negative (-)
Maximum Length	10.25" (26 cm)
Maximum Width	6.88" (17 cm)
Maximum Height	10" (25 cm)

### FLUID CAPACITY

Crankcase Oil	See Engine Manual
Fuel	7 gallon (26.5 liters)
Hydraulic Fluid	10 gallon (37.8 liters)
Grade of Hydraulic Fluid	SAE 10W-40 API Service SJ or higher Motor Oil

## OPTIONAL EQUIPMENT

15-618	Water Meter Kit (liters)	30-003	20' Contour Spray Boom
14-515	Water Meter Kit (gallons)	33-542	Triple Nozzle Kit for 20" Booms
15-622	Canopy	17-503	20' Spray Boom w/ Diaphragm Valve
30-004	Foam Marker	30-009	Manual Hose Reel
30-006	Clear water Wash Tank	30-010	Electric Hose Reel
30-007	Chemical Cleanload		



## MAINTENANCE



Before servicing or making adjustments to machine, stop engine and remove key from ignition.

**NOTE:** Use all procedures and parts prescribed by the manufacturer's. Read the engine manual before operation.

### LUBRICATION

Use No. 2 General purpose lithium base grease and lubricate every 100 hours. The Spray Star 3180 has 6 grease fittings.

- A. One on the rod end of hydraulic cylinder.
- B. One on each the right and left spindles.
- C. One on the center front pivot.
- D. One on the idler arm.
- E. One on each of the pedal relays.
- F. One on each planetary drive.

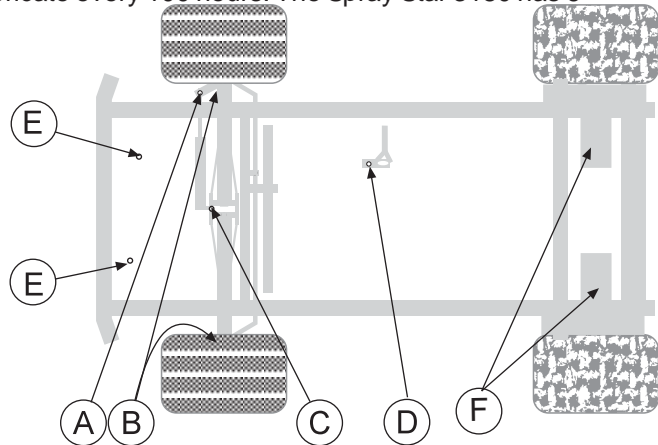

### ELECTRICAL CONNECTIONS

Use dielectric grease on all electrical connections.

### AIR CLEANER ON ENGINE

Since the air cleaner on this engine is a dry type, never apply oil to it.

1. Open evacuator valve (see engine manual) once a week to remove large particles of dust and dirt.
2. Wipe the inside of the air cleaner with a cloth if it gets wet or dirty.
3. Avoid touching the element except when cleaning.
4. When dust adheres to the element, gently tap element on flat surface.
5. When carbon or oil adheres to the element clean according to engine manual.
6. Replace the element every year or every 6 months.
7. **IMPORTANT** - Make sure wing bolt for the element is tight enough. If it is loose, dust and dirt may be sucked in, wearing down the cylinder liner and piston ring, resulting in poor power output.

**NOTE:** Do not use petroleum solvents, e.g., kerosene, which will cause cartridge to deteriorate. Do not use pressurized air to clean cartridge. Pressurized air can damage cartridge.

### FUEL

#### CHECK EMISSION REGULATIONS OF YOUR AREA

With Emission control now in effect diesel fuel specification type and sulfur content % (ppm) used must be in compliant with all applicable emission regulations for the area in which the engine is operated.

Use of diesel fuel with sulfur content less than 0.10% (1000 ppm) is strongly recommended.

If high sulfur fuel is used, change oil and oil filters twice as often.

DO NOT USE Fuels that have sulfur content greater than 1.0% (10000 ppm).

Diesel fuels specified in EN 590 or ASTM D975 are recommended.

Since KUBOTA diesel engines of less than 56kW (75 hp) utilize EPA Tire 4 and Interim Tier 4 Standards, the use of low sulfur fuel or ultra low sulfur fuel is mandatory for these engines, when operated in US EPA regulated areas. Therefore, use No.2-D S500 or S15 diesel fuel as a alternative toe No. 2-D for ambient temperatures below -10°C (14° F).



ENGINE OIL

With strict emission control regulations now in effect, the CF-4 and CG-4 engine oils have been developed for use with low sulfur fuels, for On-Highway vehicle engines. When Non-Road engines run on high sulfur fuel, it is advisable to use a "CF or better" classification engine oil with Total Base Number (a minimum TBN of 10 is recommended).

Check the engine oil before starting or more than 5 minutes after stopping the engine. If oil level is low, remove oil filler plug and add new oil to the prescribed level. Do not overfill. Engine oil should be MIL-L2104C or have properties of API Classifications CD grades or higher. Change the type of Engine oil according to the ambient temperature.

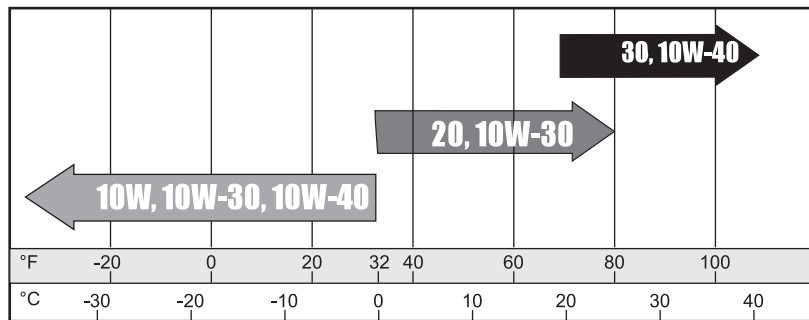

Starting Temperature Range Anticipated Before Next Oil Change

HYDRAULIC OIL

1. Use SAE 10W-40 API Service SJ or higher motor oil.
2. For proper warranty, change oil every 500 hours or annually, which ever is first.
3. Oil level should be 2-2½" (5-6.4cm) from top of the tank when fluid is cold. Do not overfill.
4. After changing oil, run the machine for a few minutes. Check oil level and for leaks.
5. Always use extreme caution when filling hydraulic oil tank or checking level to keep system free of contaminants. Check and service more frequently when operating in extremely cold, hot or dusty conditions.
6. If the natural color of the fluid has become black or smells burnt, it is possible that an overheating problem exists.
7. If fluid becomes milky, water contamination may be a problem.
8. If either of the above conditions happen, change oil immediately after fluid is cool and find the cause. Take fluid level readings when the system is cold.
9. In extreme temperatures you can use straight weight oil. We recommend SAE 30W API Service SG when hot (above 90°F (33°C)) and SAE 10W API Service SJ or higher when cold (below 32°F (0°C) ambient temperature. Use either motor oil or hydraulic oil, but do not mix.
10. Oil being added to the system must be the same as what is already in the tank. Mark the tank fill area as to which type you put in.

TIRE PRESSURE

Caution must be used when inflating a low tire to recommended pressure. Over inflating can cause tires to explode. Front tires should be 20 psi (1.4bar) and rear tires should be 30 psi (2.0bar). Improper inflation will reduce tire life considerably.

## MAINTENANCE

### BATTERY

Batteries normally produce explosive gases which can cause personal injury. Do not allow flames, sparks or any ignited object to come near the battery. When charging or working near battery, always shield your eyes and always provide proper ventilation.

Battery cable should be disconnected before using "Fast Charge".

Charge battery at 15 amps for 10 minutes or 7 amps for 30 minutes. Do not exceed the recommended charging rate. If electrolyte starts boiling over, decrease charging.

Always remove grounded (-) battery clamp first and replace it last. Avoid hazards by:

1. Filling batteries in well-ventilated areas.
2. Wear eye protection and rubber gloves.
3. Avoid breathing fumes when electrolyte is added.
4. Avoid spilling or dripping electrolyte.



**WARNING**

**Battery Electrolyte is an acidic solution and should be handled with care. If electrolyte is splashed on any part of your body, flush all contact areas immediately with liberal amounts of water. Get medical attention immediately.**

**Use of booster battery and jumper cables. Particular care should be used when connecting a booster battery. Use proper polarity in order to prevent sparks.**

TO JUMP START (NEGATIVE GROUNDED BATTERY):

1. Shield eyes.
2. Connect ends of one cable to positive (+) terminals of each battery, first (A) then (B).
3. Connect one end of other cable to negative (-) terminal of "good" battery (C).
4. Connect other end of cable (D) to engine block on unit being started (NOT to negative (-) terminal of battery)

To prevent damage to other electrical components on unit being started, make certain that engine is at idle speed before disconnecting jumper cables.

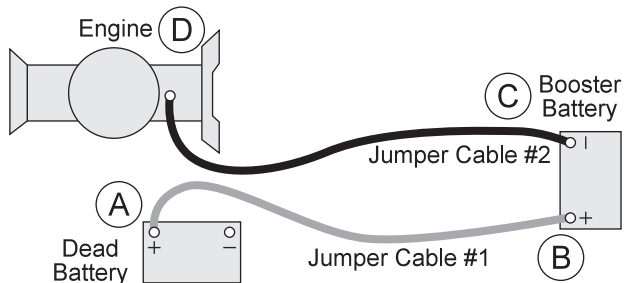

## WHEEL CREEP

### WHEEL CREEP

"Creep" is when the engine is running and hydrostatic transmission is in neutral, but due to inadequate alignment, wheels still move. Do the following procedure to stop this motion.

1. Lift up and support machine so rear wheels are off the ground and can turn freely.
2. In the engine compartment, the hydrostatic pump is on the right side. The shift arm (D) is on top of the pump. The idler arm (B) has a bearing that rides in the vee of the shift arm. Loosen bolt (A).
3. With engine running, move bearing (B) so it centers on the shift arm (D) and 'wheel creep' stops.
4. Tighten all fasteners and test by using foot pedal linkage to see that 'creep' is removed.
5. Turn engine off and lower machine.

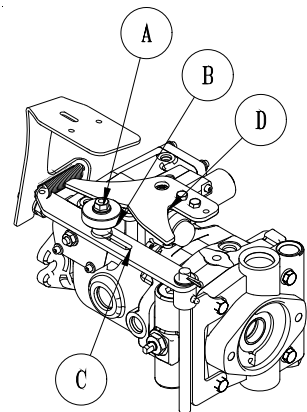



#### SPRAY PUMP WITH BELT

Located to the right of the engine. The belt should have approximately  $\frac{1}{2}$ " (13mm) of deflection in the center of the top strand. Loosen and tighten the  $\frac{5}{16}$  -18 x  $1\frac{1}{4}$  set screw located on the foot of the pump mount.

#### SAFETY INTERLOCK SWITCH

To adjust the interlock switch on the back hydrostatic pump loosen the set screw on the front half of the switch, with the ignition switch OFF. With a continuity tester connected across the switch, it should light with the shift arm centered. Move the shift arm to the right or left and the light should go off. By turning the back half of the switch clockwise it will reduce the amount of travel on the shift arm that is required for the light to remain on. The light must be on **ONLY** with the shift arm centered.

#### MASTER BOOM SWITCH (FOOT SWITCH)

The master boom switch, located on the left floorboard is used to override the master switch on the computer console of the spray systems. By pushing down it will turn on/off the booms. *For the 440 System* the Master Switch on the computer **must be off** for the master boom control switch to work.

#### GROUND SPEED CONTROL (FOOT SWITCH)

The ground speed control does not work the same as an automotive type cruise. The ground speed control is located on the center floorboard and is used to lock forward speed.

#### TO ENGAGE:

1. Flip rocker switch 'On' (green light).
2. Obtain desired speed with foot pedal.
3. Step on foot switch to lock speed.
4. Push foot switch again to disengage.

#### SPEED CALIBRATION NUMBERS

The speed calibration numbers for the Spray Star 3182 is 612.

#### SPRAY BOSS CONTROL

Engages and disengages speed boss. Forward is engage and all the way back is disengage. When the lever is engaged it sets a stop for the accelerator. The accelerator pedal must be used to maintain this speed. To adjust speed use the knob on the end of the lever, counter clockwise increases speed and clockwise decreases speed. Disengage the lever and you will have full accelerator pedal range.

#### TOWING

When it is necessary to move the Spray Star 3180 without the engine running, there are 2 things that need to be done. First, the bypass valve built into hydrostatic pump must be "open" by turning it  $\frac{1}{4}$  turn to open. The valve is located on the back side of the pump. An "open" valve allows fluid to pass through the wheels freely. When normal driven operation is desired, valve should be "closed" by turning it clockwise. Failure to "close" the valve with engine running means no power to wheels. Secondly, the hand brake needs to be manually released. The hand brake is located under the engine. To manually release the brake you must loosen the locknut and screw in the stem to the bottom. Tighten the lock nut and pump handle until hard.

#### MANUAL BRAKE HAND PUMP MANIFOLD

The hand brake is located under the engine. The hand brake is connected to the seat switch and automatically engages when operator gets up from the seat. So when machine is not being driven, the machine is locked down. If engine is not running or you are towing the machine you will have to manually release the brake. **To manually release the brake** you must loosen the locknut and screw in the stem to the bottom. Tighten the lock nut and pump handle until hard.

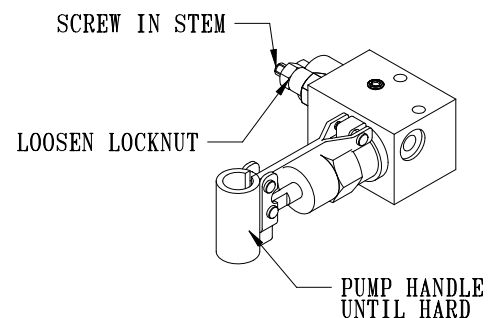



Before servicing or making adjustments to the machine, stop engine, block wheels and remove key from ignition.



Follow all procedures and **ONLY** use parts prescribed by the manufacturer. Read the engine manual before maintenance.

The suggested maintenance checklist is not offered as a replacement for the manufacturer's engine manual but as a supplement. You must adhere to the guidelines established by the manufacturer for warranty coverage. In adverse conditions such as dirt, mud or extreme temperatures, maintenance should be more frequent.

Maintenance Service Interval	Maintenance Procedure
After the first 50 operating hours	Torque the wheel lug nuts. (64-74 ft/lb (87-100 Nm)) Change the engine oil and filter.
After the first 20 operating hours	Replace hydraulic filter
Before each use daily	Check the engine oil. Check the hydraulic fluid level. Check the tire pressure. Check condition of hydraulic hoses and fittings. Inspect and clean the machine. Inspect cooling system.
Every 100 hours	Check the battery fluid level and cable connections. Change hydraulic filter Check engine for leaks or loose parts. Check air cleaner. Check tire pressure (20 psi front (30 psi) rear). Torque the wheel lug nuts. (64-74 ft/lb (87-100 Nm)) Grease Machine. Check Planetary for oil. Check belt tension (where needed)
Every 200 Hours	Ceck radiator hoses.
	Change the engine oil and filter. Change oil filter Change hydraulic filter Clean battery terminals
Every 400 hours	Replace Fuel Filter
Every 500 hours or yearly	Lubricate machine Visual inspection of machine and hydraulic hoses Change oil. Torque lug nuts. Check battery terminals and electrolyte level. Change all filters.





## STORAGE

**NOTE:** To prevent damage from freezing, pour window washer fluid into spray systems tank and operate pump to circulate mix through gun and hose back to tank. Open boom control to circulate through rest of spray system.

### UP TO ONE MONTH

1. While engine is running, treat upper cylinders by spraying engine fogging agent into the air intake (NOT through air cleaner) for about two minutes. Fogging agent can be obtained from your local after market supplier. Open throttle for short burst of speed, shut off ignition and allow engine to come to a stop while continuing to spray fogging agent into air intake.
2. Leave spark plugs in holes or seal spark plug holes with suitable threaded metal plugs and cover all openings into engine with suitable non-hygroscopic material.
3. Check coolant protection. Store machine indoors in dry area.

### TWO MONTHS

1. Clean the exterior surfaces of the engine.
2. Change the oil and filter while the engine is still warm from operation.
3. Drain coolant from the radiator. Open cock at the bottom of the radiator, and remove the pressure cap to drain water completely. Leave the cock open. Hang a not written "No Water" on the pressure cap. Since water freezes when temperature drops below 0°C (32° F) it is important that no water is left in the machine.
4. Remove battery from the engine, adjust the electrolyte level, and recharge it. Store battery in a dry dark place.
5. Store machine in a clean, dry place.

### EXTENDED STORAGE

1. Check for any damaged parts or missing decals. Replace as needed.
2. Drain crankcase completely and refill with recommended engine oil or equivalent.
3. Run engine until completely out of gasoline, then restart and run on stabilizer mixed with unleaded gasoline for at least 10 minutes.
4. While engine is still running and at completion of above run, treat upper cylinders by spraying fogging agent into the air intake for about two minutes. Open throttle for short burst of speed, shut off ignition and allow engine to come to a stop while continuing to spray fogging agent into air intake (NOT through air cleaner).
5. Lubricate all grease points.
6. Check coolant protection and level.
7. Clean exterior surface of engine.
8. Leave spark plugs in holes or seal spark plug holes with suitable threaded metal plugs.
9. Seal all openings in engine and accessories with non-hygroscopic material. Mask off all areas to be used for electrical contact.
10. Tape all openings and make sure all surfaces are dry. Then spray all taped openings, all engine accessories including ignition wiring, and all exterior surfaces of engine with Insulation Compound.
11. Disconnect, remove and clean battery. Check electrolyte level. Charge the battery and store in a cool dry place (NOT directly on cement).
12. Put blocks or stands under the machine to take weight off tires.

### AFTER STORAGE

1. Check for any damaged parts or missing decals. Replace as needed.
2. Lubricate all grease points.
3. Clean exterior surface of engine.
4. Replace spark plugs if previously removed.
5. Remove all tape and obstructions from exterior engine surfaces.
6. Charge and replace battery.
7. Check tire pressure.
8. Remove blocks or supports from under the machine.
9. Check engine oil level and coolant level and lubricate all grease points.
10. Fill fuel tank.
11. Check belt tension.
12. Run engine approximately 5 minutes before putting the engine under load.

# WIRING DIAGRAM

REF#	PART#	DESCRIPTION	QUANTITY
1	77-223	Timer	1
	30-042-06	Relay	1
2	50-359	Warning Light	3
3	10-202	Speedometer	1
4	12-017	Hour Meter	1
5	14-272	Seat Switch	1
6	13-488	Ignition Switch	1
7	34-201	Lights	2
8	15-725	Mount Panel End	1
	15-727	Switch Actuator	1
	15-782	Rocker Switch, Unlit	1
9	15-729	Mount Panel Middle	1
	15-726	Switch Body, Light	1
	15-732	Actuator, Green	1
10	15-729	Mount Panel Middle	1
	15-726	Switch Body, Light	1
	15-731	Actuator, Amber	1
11	15-729	Mount Panel Middle	1
	15-727	Switch Actuator	1
	15-728	Switch Body, On-Off-On	1

## Color Code Chart

Bl	Blue
Br	Brown
Y	Yellow
G	Green
O	Orange
R	Red
B	Black
P	Purple
W	White

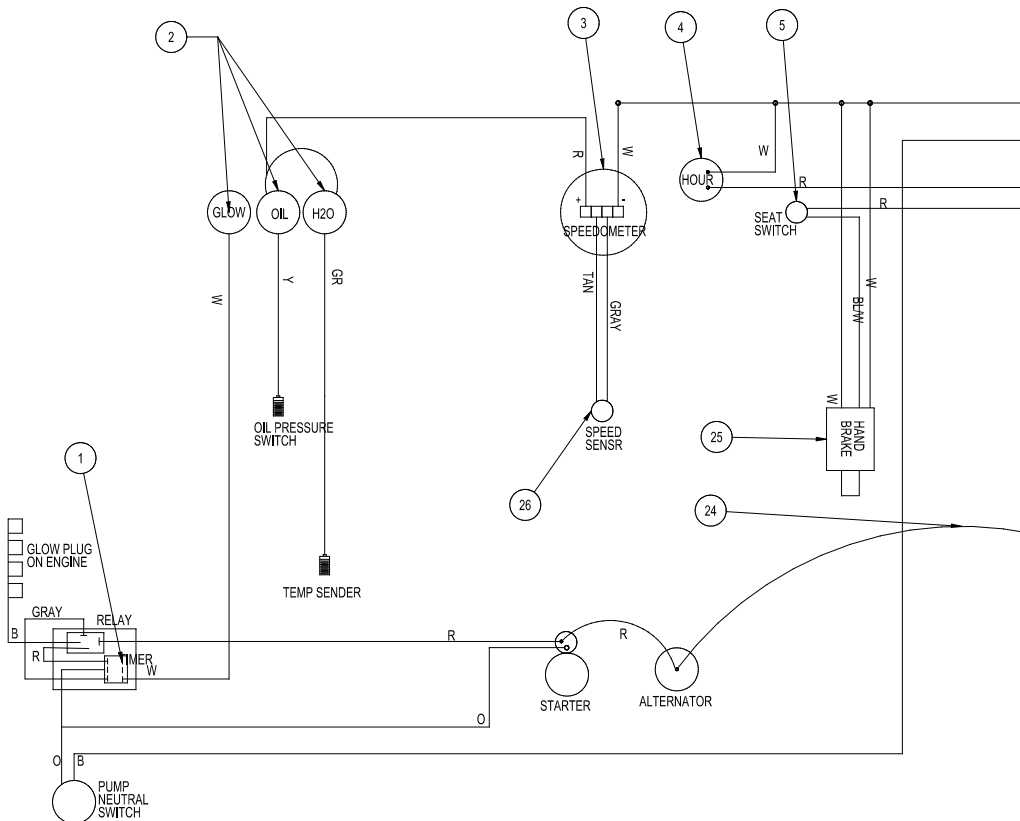

# WIRING DIAGRAM

REF#	PART#	DESCRIPTION	QUANTITY
12	15-725	Mount Panel End	1
	15-727	Switch Actuator	1
	15-728	Switch Body, On-Off-On	1
13	77-207	Buzzer	1
14	16-998	Hypro Pump	1
15	15-743	3-Way ball Valve	1
16	33-480	Pressure Switch	1
17	33-271	Buss Bar	1
	33-272	Fuse, 15 AMP	1
	33-273	Fuse, 30 AMP	2
18	33-509	Cruise Foot Switch	1
19	30-107	Wire Harness Battery ground to Fuse	1
20	33-084	Magnetic Coil	1
21	48-147	Ground Battery Cable	1
22	33-216	Battery	1
23	30-106	Wire Harness Battery to Fuse	1
24	78-325	Positive Battery Cable	1
25	30-104	Manual Hand Brake	1
26	16-883	Speed Sensor	1
NA	30-053	Main Wire Harness	1
NA	30-054	Engine Wire Harness	1

Service

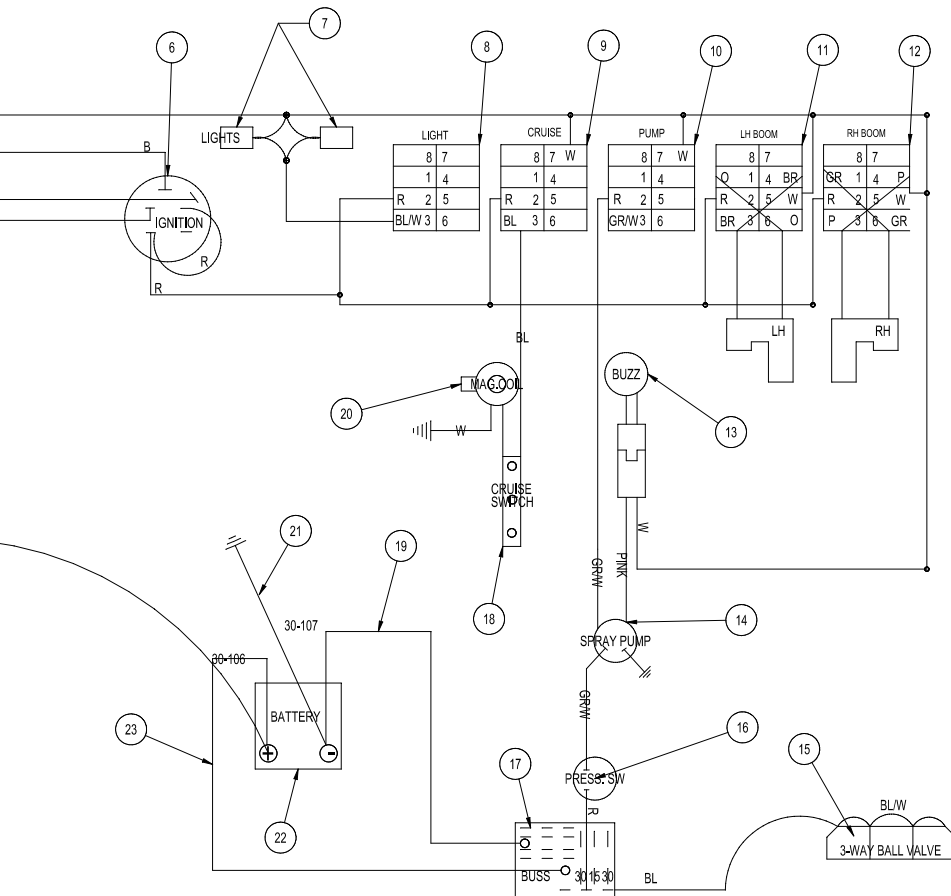

# HYDRAULIC DIAGRAM

Use dielectric grease on all electrical connections.

Diagrams

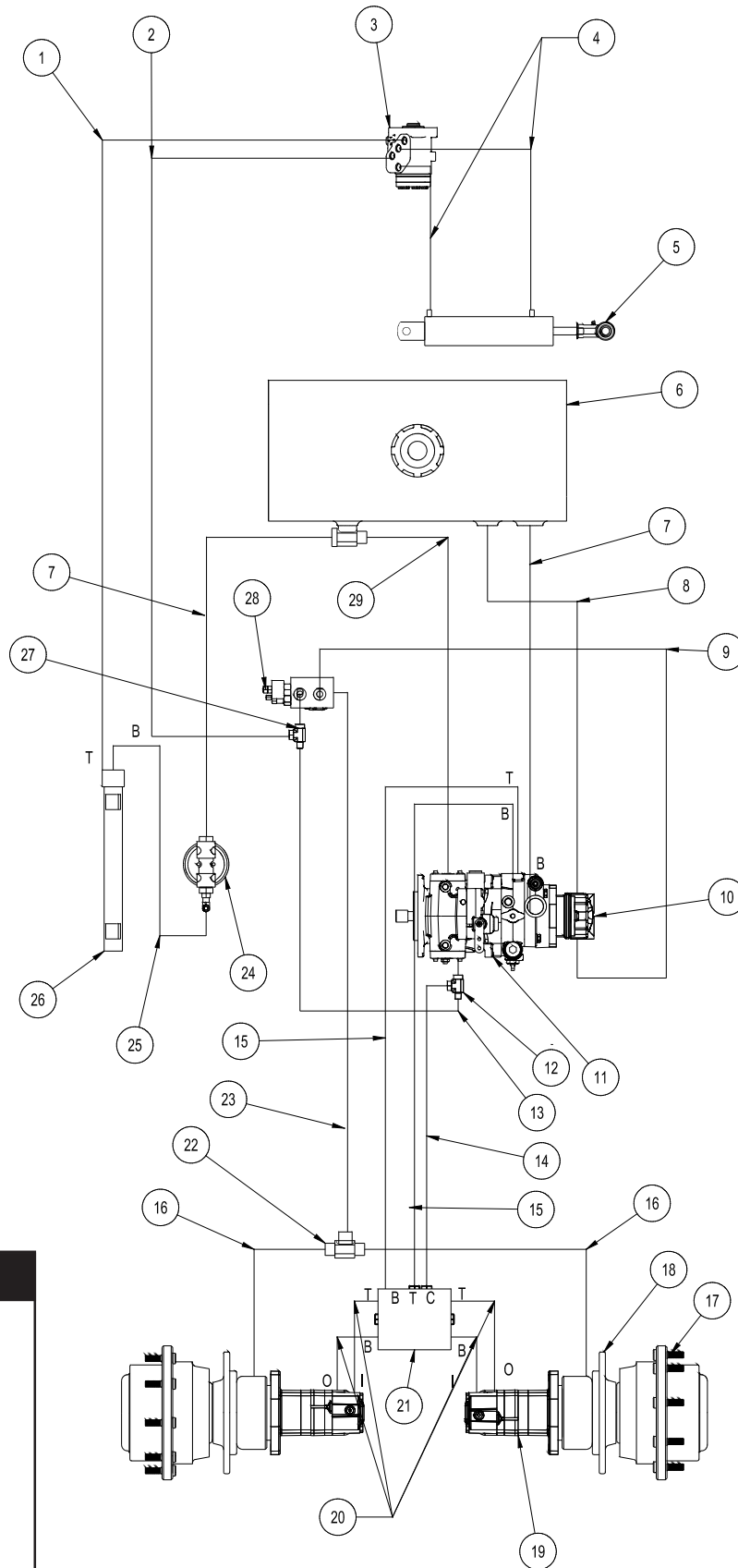

## Letter Code Chart

C	Center
I	Inside
O	Outside
T	Top
B	Bottom



## HYDRAULIC DIAGRAM PARTSLIST

REF#	PART#	DESCRIPTION	QUANTITY
1	30-092	Hydraulic Hose	1
2	30-091	Hydraulic Hose	1
3	15-301	Orbitrol	1
4	30-094	Hydraulic Hose	2
5	75-714	Hydraulic Cylinder	1
	14-254	Seal Kit	1
	18-171	3/8 Seal Loc Adapter	2
6	30-025	Oil Tank	1
	13-747	Filler Breather	1
	13-586-03	Neck	1
7	8833-9	Suction Hose	2
	18-222	Hose Clamp	4
8	8833-17	Suction Hose	1
	18-222	Hose Clamp	1
9	30-093	Hydraulic Hose	1
10	30-098	Gear Pump	1
11	30-102	Eaton Closed Loop Pump	1
12	18-405	Run Tee	1
13	30-086	Hydraulic Hose	1
14	30-085	Hydraulic Hose	1
15	30-090	Hydraulic Hose	2
16	30-087	Hydraulic Hose	2
17	30-099	Wheel Drive	2
18	30-100	Hydraulic Release Brakes	2
19	30-101	Eaton Wheel Motors	2
20	30-089	Hydraulic Hose	4
21	30-103	Hot Oil Shuttle Manifold	1
22	18-395	Union Tee	1
23	30-088	Hydraulic Hose	1
24	60-215	Oil Filter Assembly	1
	60-334	Replacement Element	1
25	8833-23	Suction Hose	1
	18-222	Hose Clamp	2
26	30-105	Oil to Air Heat Exchanger	1
27	18-308	Swivel Tee	1
28	30-104	Brake and Manual Hand Pump Manifold	1
29	8917-15.5	Suction Hose	1
	18-040	Hose Clamp	2

# BODY & FRAME DRAWING

Diagrams

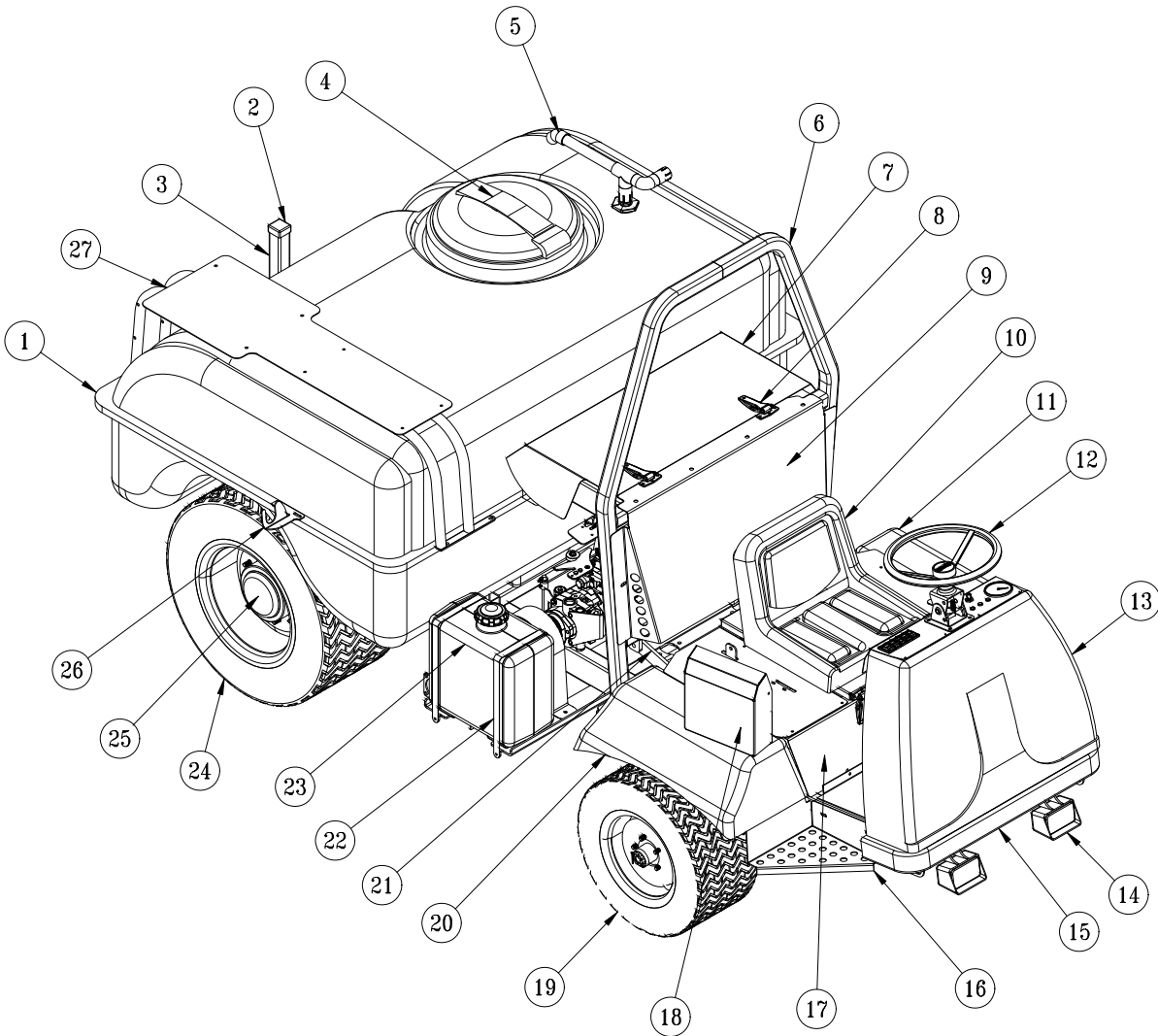

## BODY & FRAME PARTS LIST

REF#	PART#	DESCRIPTION	QUANTITY
1	30-095	318 Gallon Tank (Fiberglass)	1
	25-372	Decal, Smithco 4" Star	1
	30-016	Decal, Spray Star 3180	2
2	16-557	Square cap	2
3	14-325	Boom Carrier	2
	HB-12-13-150	Bolt $\frac{1}{2}$ - 13 x $1\frac{1}{2}$	4
	HNFL-12-13	Flange Lock Nut $\frac{1}{2}$ - 13	4
4	16-953	16" Hinged Lid Well	1
5	14-365	Air Gap Filler	1
6	30-030	Roll Bar	1
7	30-075	Engine Hood	1
8	27-055	Flush Hinge	2
9	15-756	Back Panel	1
10	14-519	Seat	1
	14-272	Seat Switch	1
11	30-114	Left Front Fender	1
12	13-718	15" Steering Wheel	1
	13-726	Center Cap	1
13	15-763	Nose Cone (Fiberglass)	1
14	34-201	Light	2
	HSDPS-14-075	Pan Head Drill Screws $\frac{1}{4}$ x $\frac{3}{4}$	4
15	30-020	Main Frame	1
16	15-752	Left Step	1
	15-751	Right Step	1
17	30-065	Front Panel	1
	27-055	Flush Hinge	1
18	15-716	Control Box (part of 440 system)	1
19	43-124	Turf Tread Tire and Wheel	2
	43-123-01	Tire	2
	43-058-01	Wheel	2
	HNL-12-20	Lug Nut $\frac{1}{2}$ - 20	14
20	30-113	Right Front Fender	1
21	30-032	ROPs Support	2
22	73-051	Fuel Tank Strap	2
23	73-049	Fuel Tank	1
	30-026	Cap with Gauge	1
24	30-048-01	Rear Tire	2
25	30-048-02	Rear Wheel	2
	HNL-12-20	Lug Nut $\frac{1}{2}$ - 20	14
26	30-035	Left Boom Holder	1
	30-034	Right Boom Holder	1
27	30-110	Accessory Mount Bracket	1
	HB-516-18-175	Bolt $\frac{5}{16}$ - 18 x $1\frac{3}{4}$	4
	HW-516	Washer $\frac{5}{16}$	4
	HNFL-516-18	Flange Lock Nut $\frac{5}{16}$ - 18	4

# NOSE CONE DRAWING

Parts

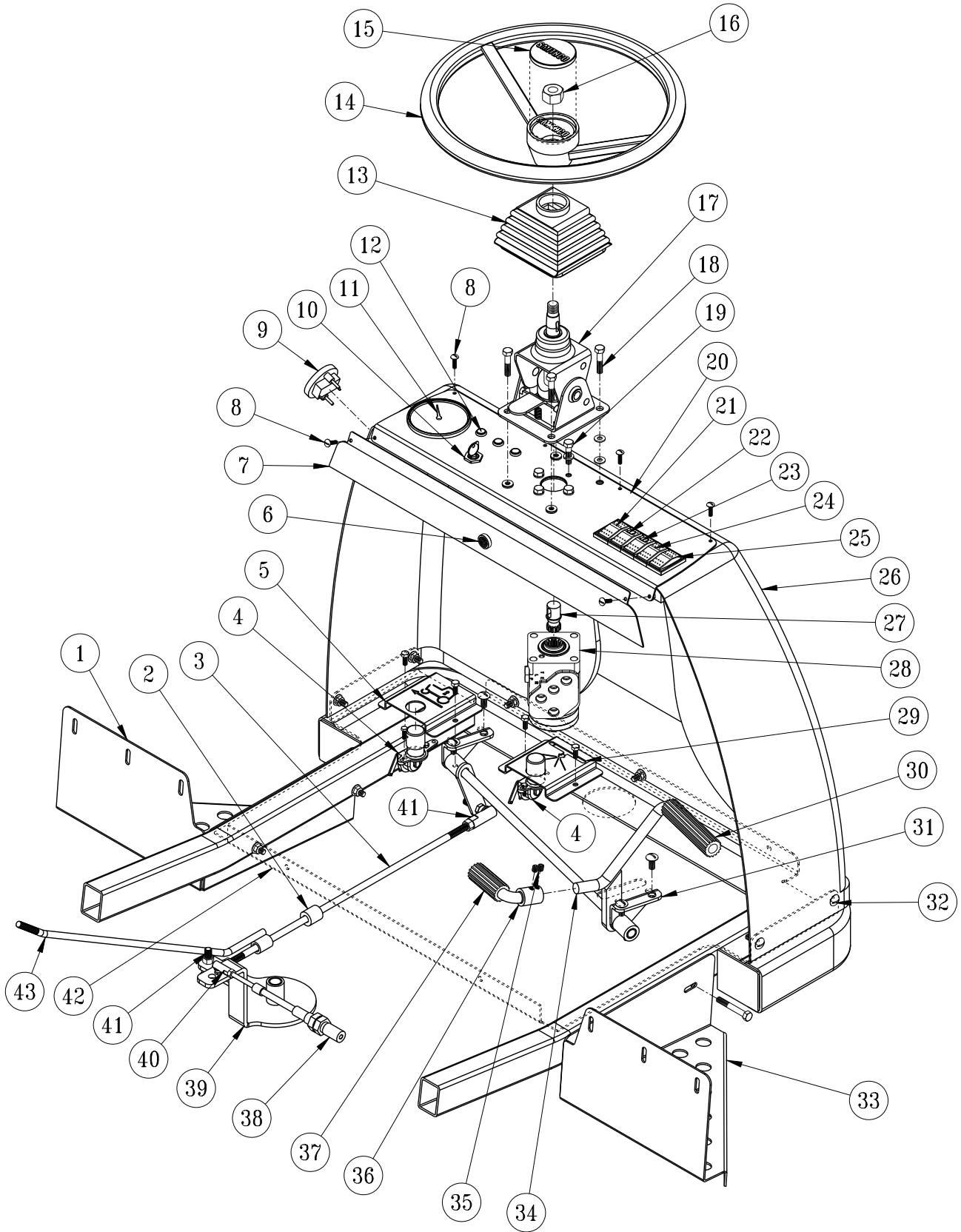

# NOSE CONE PARTSLIST

REF#	PART#	DESCRIPTION	QUANTITY
1	15-751	Right Step	1
2	30-066	Crusie Stop	1
	HSSH-14-28-031	Set Screw $1/4 - 28 \times 5/16$	1
3	30-049	Control Rod	1
4	33-509	Master Control Switch	2
	HSTP-14-20-075	Machine Screw $1/4 - 20 \times 3/4$	4
5	15-757	Cruise Switch Plate	1
	HB-14-20-075	Bolt $1/4 - 20 \times 3/4$	2
	HNFL-14-20	Flange Lock Nut $1/4 - 20$	2
6	77-207	Buzzer	1
7	15-721	Wire Cover	1
8	HSM-10-32-100	Machine Screw 10 - 32 x 1	6
	HWLM-6	Lock Washer #6	6
	HNFL-10-32	Flange Lock Nut 10-32	6
9	12-017	Hour Meter	1
10	13-488	Key Switch	1
11	10-202	Speedometer	1
12	50-359	Warning Indicator Lights	3
13	76-364	Square Boot	1
14	13-718	Steering Wheel	1
15	13-726	Center Cap	1
16	HNJ-58-18	Jam Nut $5/8 - 18$	1
17	76-362	Tilt Steering Column	1
18	HB-516-18-125	Bolt $5/16 - 18 \times 1 1/4$	4
	HW-14	Washer $1/4$	4
	HNFL-516-18	Flange Lock Nut $5/16 - 18$	4
19	HBM-6-1-16	Metric Bolt	4
	HWLM-6	Metric Lock Washer	4
20	15-754	Dash Panel	1
	30-017	Decal, Dashboard	1
21	Lights		
	15-725	Mount Panel End	1
	15-727	Switch Actuator	1
	15-782	Rocker Switch, Unlit	1
22	Cruise Control		
	15-729	Mount Panel Middle	1
	15-726	Switch Body, Light	1
	15-732	Actuator, Green	1
23	Spray Pump		
	15-729	Mount Panel Middle	1
	15-726	Switch Body, Light	1
	15-731	Actuator, Amber	1
24	Right Boom		
	15-729	Mount Panel Middle	1
	15-727	Switch Actuator	1
	15-728	Switch Body, On-Off-On	1
25	Left Boom		
	15-725	Mount Panel End	1
	15-727	Switch Actuator	1
	15-728	Switch Body, On-Off-On	1
26	15-763	Nose Cone (Fiberglass)	1
27	48-187	Stub Shaft	1
28	15-301	Orbitrol	1
	7-867	#6 SAE Adapter	4

# NOSE CONE DRAWING

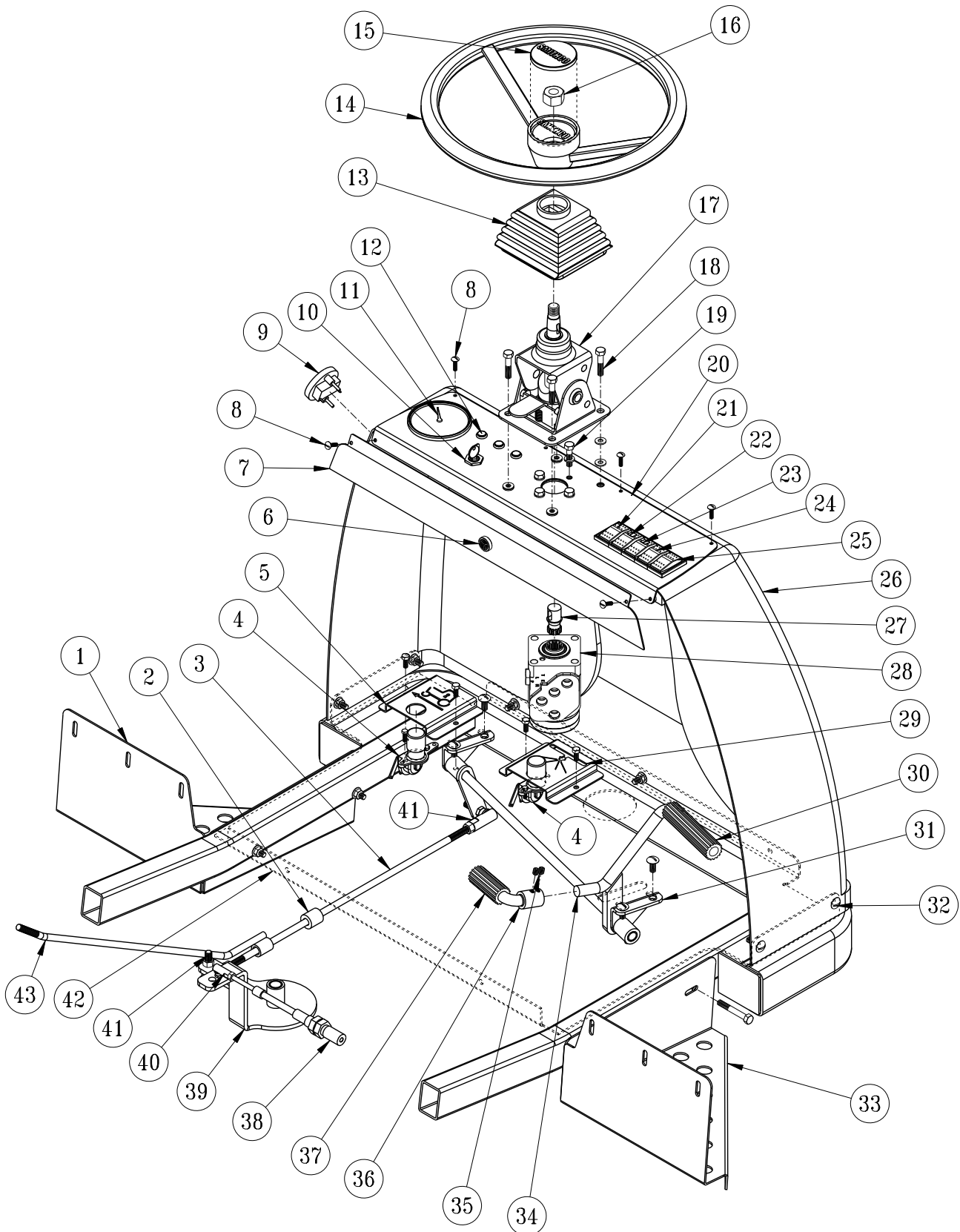

Parts

## NOSE CONE PARTSLIST

REF#	PART#	DESCRIPTION	QUANTITY
29	15-758	Sprayer Switch Plate (part of 440 system)	1
	HB-14-20-075	Bolt $\frac{1}{4}$ - 20 x $\frac{3}{4}$	2
	HNFL-14-20	Flange Lock Nut $\frac{1}{4}$ - 20	2
30	76-299	Pedal Pad	1
31	76-296	Pedal Mount	2
	HSTP-516-18-075	Machine Screw $\frac{5}{16}$ - 18 x $\frac{3}{4}$	4
	HNFL-516-18	Flange Lock Nut $\frac{5}{16}$ - 18	4
32	HSTP-516-18-150	Machine Screw $\frac{5}{16}$ - 18 x $1\frac{1}{2}$	7
	HNFL-516-18	Flange Lock Nut $\frac{5}{16}$ - 18	7
33	15-752	Left Step	1
34	15-820	Foot Pedal Assembly	1
	HG-14-28-180	Grease Fitting $\frac{1}{4}$ - 28 x 180°	2
	HMB-12-14	Machine Bushing $\frac{1}{2}$ x 14GA	5
35	HSSHS-516-18-038	Socket Head Set Screw, $\frac{5}{16}$ - 18 x $\frac{3}{8}$	2
36	15-821	Reverse Pedal	1
37	76-332	Pedal Pad	1
38	13-632	Push Pull Cable	1
39	15-692	Pedal Relay	1
	33-084	Magnetic Coil	1
40	18-115	Ball Joint $\frac{1}{4}$ NF	1
	HN-14-20	Nut $\frac{1}{4}$ - 20	2
	HWL-14	Lock Washer $\frac{1}{4}$	1
41	21-173	Ball Joint $\frac{3}{8}$ - 24	2
	HWL-38	Washer $\frac{3}{8}$	2
	HN-38-24	Nut $\frac{3}{8}$ - 24	4
42	30-020	Main Frame	1
43	30-047	Cruise Control Rod	1

# FRONT AXLE DRAWING

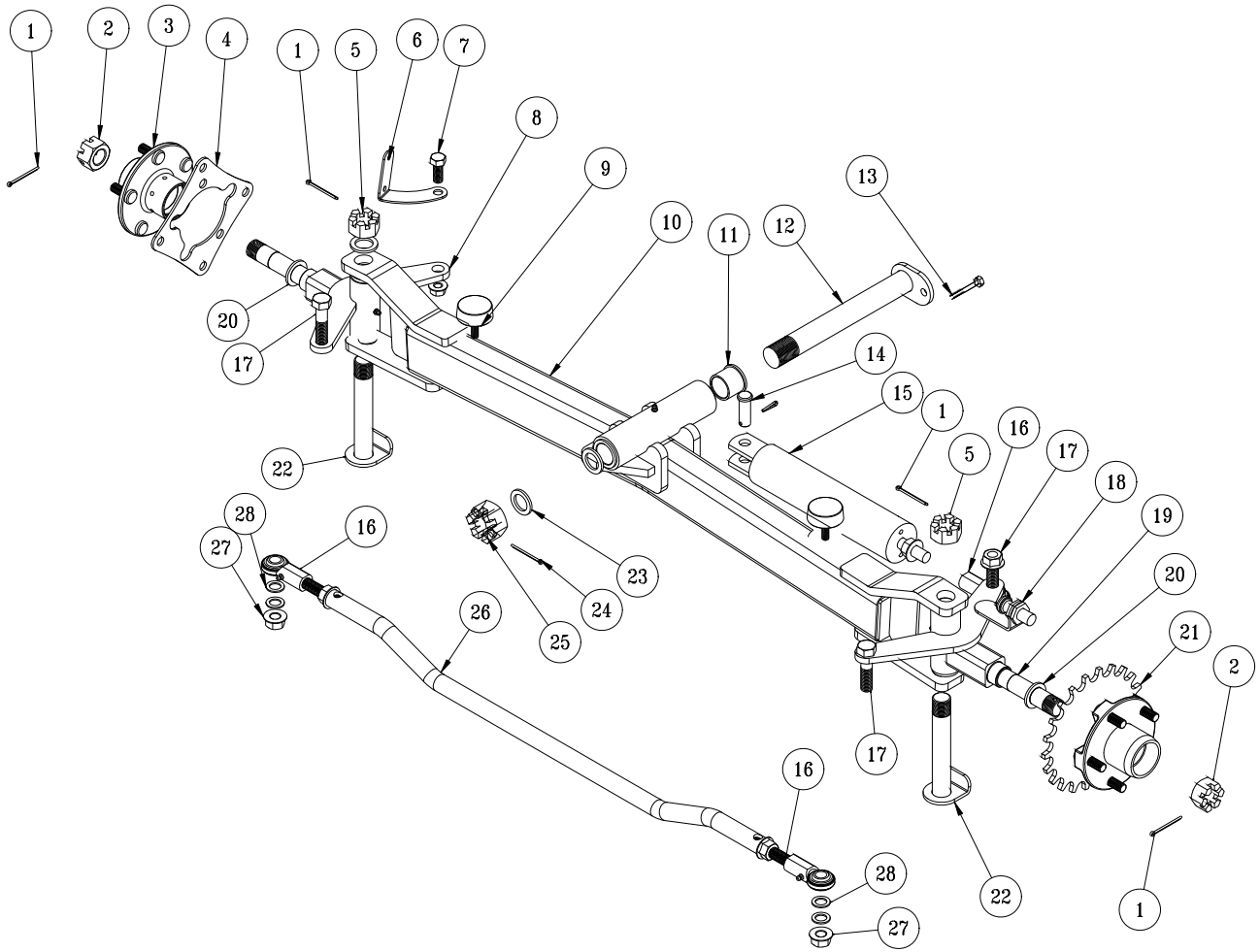

Parts



## FRONT AXLE PARTSLIST

REF#	PART#	DESCRIPTION	QUANTITY
1	HP-18-150	Cotter Pin $\frac{1}{8}$ - $1\frac{1}{2}$	2
2	HNJ-58-18	Jam Nut $\frac{5}{8}$ - 18	2
3	30-071	Hub Assembly	1
4	30-044	Magnet Mount Plate	1
5	HNAR-100-14	Slotted Jam Nut 1 - 14	2
6	15-715	Sensor Mount	1
7	HB-12-13-125	Bolt $\frac{1}{2}$ - 13 x $1\frac{1}{4}$	1
	HNFL-12-13	Flange Lock Nut $\frac{1}{2}$ - 13	1
8	30-070	Left Spindle	1
9	50-081	Rubber Insulator	2
10	30-039	Front Axle	1
11	18-153	Bushing	2
12	14-344	Axle Pin	1
13	HB-516-18-125	Bolt $\frac{5}{16}$ -18 x $1\frac{1}{4}$	1
	HNTL-516-18	Lock Nut $\frac{5}{16}$ -18	1
14	HCP-58-175	Clevis Pin $\frac{5}{8}$ x $1\frac{3}{4}$	1
	HP-18-100	Cotter Pin $\frac{1}{8}$ x 1	1
15	75-714	Hydraulic Cylinder	1
	14-254	Seal Kit	1
16	18-154	Rod End	3
	HG-14-28-90	Grease Fitting $\frac{1}{4}$ - 28 x 90°	3
17	HB-58-11-250	Bolt $\frac{5}{8}$ - 11 x $2\frac{1}{2}$	3
18	16-883	Magnetic Sensor	1
19	30-069	Right Spindle	1
20	HMB-100-10	Machine Bushing 1 x 10GA	6
21	30-072	Hub with Sprocket	1
22	16-076	King Pin	2
23	HMB-114-10	Machine Bushing $1\frac{1}{4}$ x 10GA	2
24	HP-18-200	Cotter Pin $\frac{1}{8}$ x 2	1
25	HNAT-114-12	Axle Nut $1\frac{1}{4}$ - 12	1
26	15-690	Tie Rod	1
27	HNTL-58-11	Lock Nut $\frac{5}{8}$ -11	3
28	HMB-58-14	Machine Bushing $\frac{5}{8}$ x 14GA	6

# OIL AND FUEL TANK DRAWING

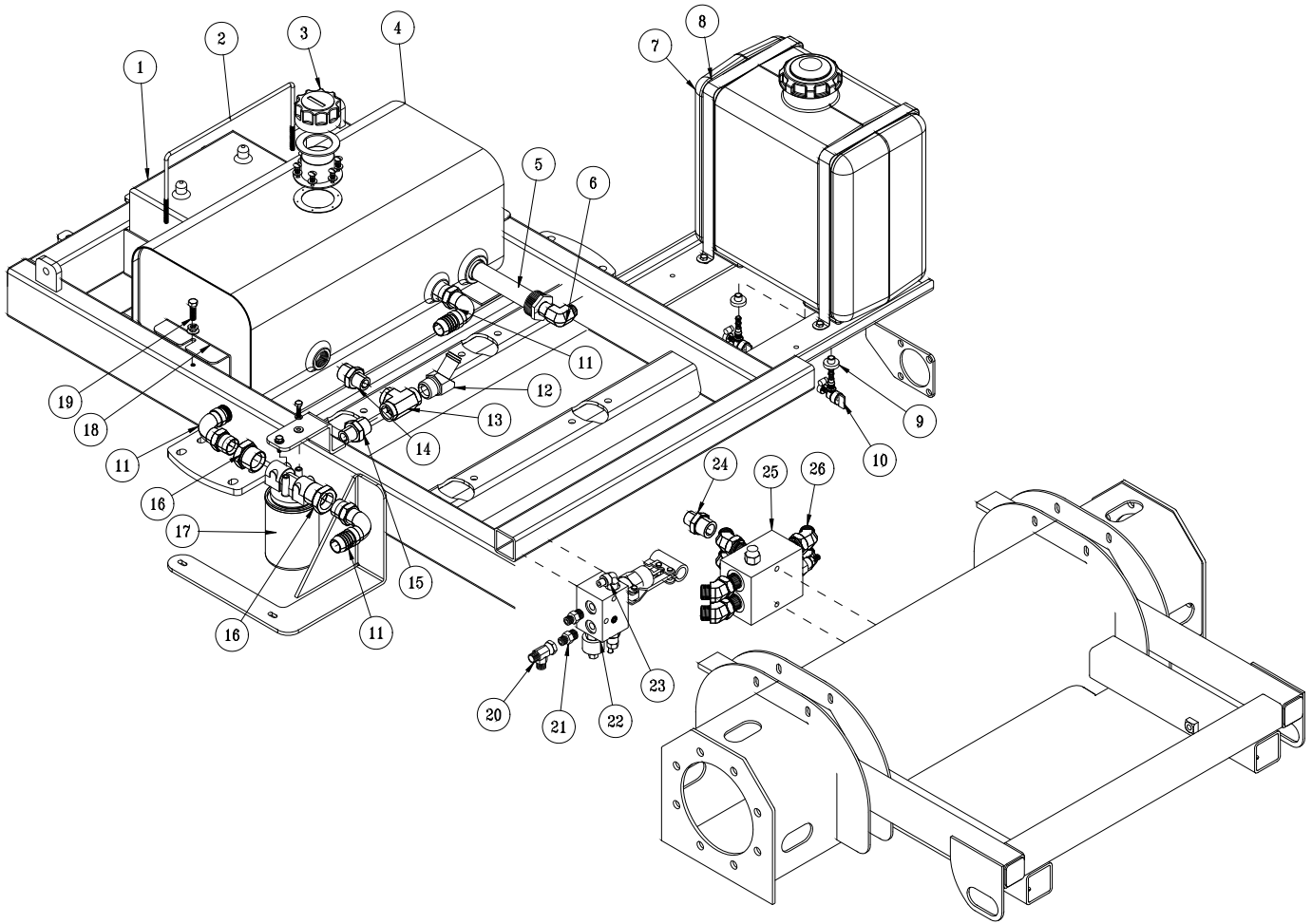

Parts

## OIL AND FUEL TANK PARTS LIST

REF#	PART#	DESCRIPTION	QUANTITY
1	33-216	Battery	1
2	30-074	Battery Hold Down	1
	HNW-14-20	Wing Nut 1/4 - 20	2
3	13-747	Filler Breather	1
	13-586-03	Fuel Tank Neck	1
	HSM-8-32-050	Machine Screw #8-32 x 1/2	6
	HWS-8	Star Washer #8	6
4	30-025	Oil Tank	1
	18-069	Pipe Plug	1
5	60-213	Strainer	1
6	18-398	90° Barb Fitting	1
7	73-049	Fuel Tank	1
	30-026	Cap with Gauge	1
8	73-051	Fuel Tank Strap	2
	HB-14-20-075	Bolt 1/4 - 20 x 3/4	2
	HB-14-20-150	Bolt 1/4 - 20 x 1 1/2	2
	HNFL-14-20	Flange Lock Nut 1/4 - 20	4
9	26-054	Bushing Insert	2
10	26-055	Shut Off Valve	2
11	18-397	90° Hose Barb Fitting	3
12	18-407	5/8 45° Hose Barb Fitting	1
13	18-399	Tee	1
14	18-400	Pipe Nipple	1
15	18-250	Barb Fitting	1
16	18-396	Reducer	2
17	60-215	Oil Filter Assembly	1
	60-334	Replacement Filter	1
18	30-063	Oil Tank Holddown	2
19	HB-38-16-125	Bolt 3/8 - 16 x 1 1/4	2
	HWL-38	Lock Washer 3/8	2
	HW-38	Washer 3/8	2
20	18-308	Swivel Tee	1
21	18-306	Straight Thread Connector	2
22	30-104	Manual Brake Pump Manifold	1
23	18-171	Seal Lock Elbow	1
24	18-321	Straight thread Connector	1
	23-126	Oring plug	1
25	30-103	Hot Oil Shuttle Manifold	1
26	18-393	Elbow	6

# SEAT PANEL DRAWING

Parts

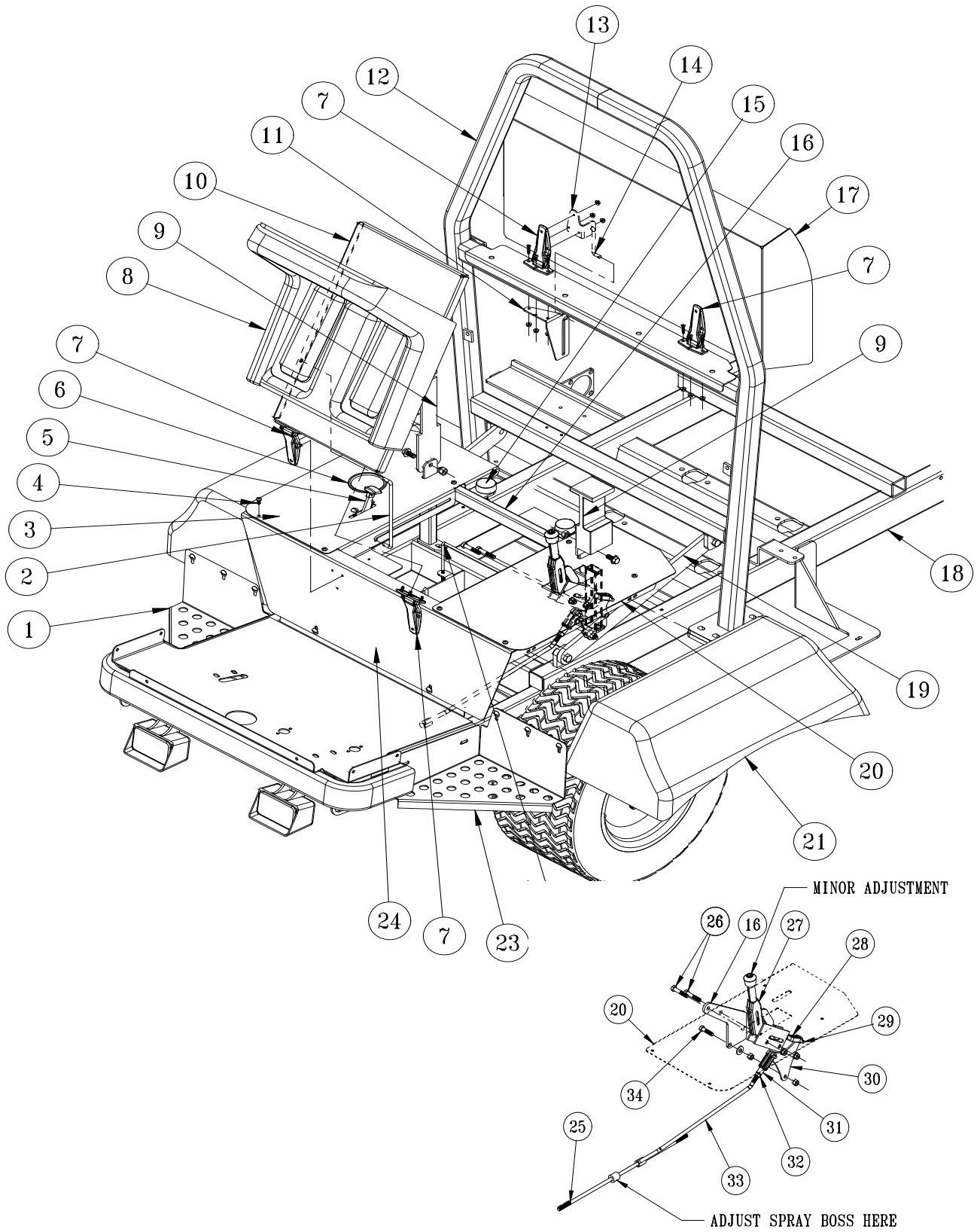

## SEAT PANEL PARTS LIST

REF#	PART#	DESCRIPTION	QUANTITY
1	15-751	Step - RH	1
2	15-786	Hood Rod	1
	HW-38	Flat Washer, $\frac{3}{8}$	4
	HP-18-075	Cotter Pin, $\frac{3}{8} \times \frac{3}{4}$	2
3	30-021	Side Panel - RH	1
	30-097	Decal, Control Panel	1
4	HSDPS-14-100	Pan Head Drill Screw, $\frac{1}{4} \times 1$	8
5	34-160	Throttle Cable	1
	34-160-01	Inner Cable	1
	42-766	Throttle Bracket	1
	HSTP-14-20-075	Phillips Head Machine Screw, $\frac{1}{4} - 20 \times \frac{3}{4}$	2
	HNFL-14-20	Flange Lock Nut, $\frac{1}{4} - 20$	2
	HSM-10-32-063	Machine Screw, #10 - 32 x $\frac{5}{8}$	4
	HNFL-10-32	Flange Lock Nut, #10 - 32	4
6	15-781	XL Drink Cup Holder	1
7	27-055	Flush Mount Hinge	4
	HSM-10-32-063	Machine Screw, #10 - 32 x $\frac{5}{8}$	24
	HNFL-10-32	Flange Lock Nut, #10 - 32	24
8	14-519	Seat, White	1
9	76-198-03	Seat Belt	1
	HB-716-14-100	Hex Bolt, $\frac{7}{16} - 14 \times 1$	2
	HW-716	Flat Washer, $\frac{7}{16}$	2
	HNTL-716-14	Lock Nut, $\frac{7}{16} - 14$	2
10	15-714	Seat Panel	1
	HLC-A-58	Loom Clamp, $\frac{5}{8}$	2
11	30-056	Lower Hood Bracket	1
12	30-030	Roll Bar	1
	HB-12-13-200	Hex Bolt, $\frac{1}{2} - 13 \times 2$	8
	HW-12	Flat Washer, $\frac{1}{2}$	16
	HNTL-12-13	Lock Nut, $\frac{1}{2} - 13$	8
13	30-055	Upper Hood Bracket	1
14	30-057	Hood Rod	1
	HP-18-075	Cotter Pin, $\frac{1}{8} \times \frac{3}{4}$	2
15	50-081	Rubber Bumper	2
	HNFL-38-16	Flange Lock Nut, $\frac{3}{8} - 16$	4
16	30-045	Seat Frame	1
	HB-38-16-500	Hex Bolt, $\frac{3}{8} - 16 \times 5$	2
	HNFL-38-16	Flange Lock Nut, $\frac{3}{8} - 16$	2
17	30-075	Engine Hood	1
18	30-020	Mainframe	1
19	30-032	Roll Bar Brace	2
	HB-12-13-200	Hex Bolt, $\frac{1}{2} - 13 \times 2$	4
	HW-12	Flat Washer, $\frac{1}{2}$	4
	HNTL-12-13	Lock Nut, $\frac{1}{2} - 13$	4
20	30-022	Side Panel - LH	1
	30-112	Decal, Speed Control	1
21	30-114	LH Fender	1
	HSTP-516-18-075	Phillips Head Machine Screw, $\frac{5}{16} - 18 \times \frac{3}{4}$	2
	HSTP-516-18-100	Phillips Head Machine Screw, $\frac{5}{16} - 18 \times 1$	3
	HNFL-516-18	Flange Lock Nut, $\frac{5}{16} - 18$	5

# SEAT PANEL DRAWING

Parts

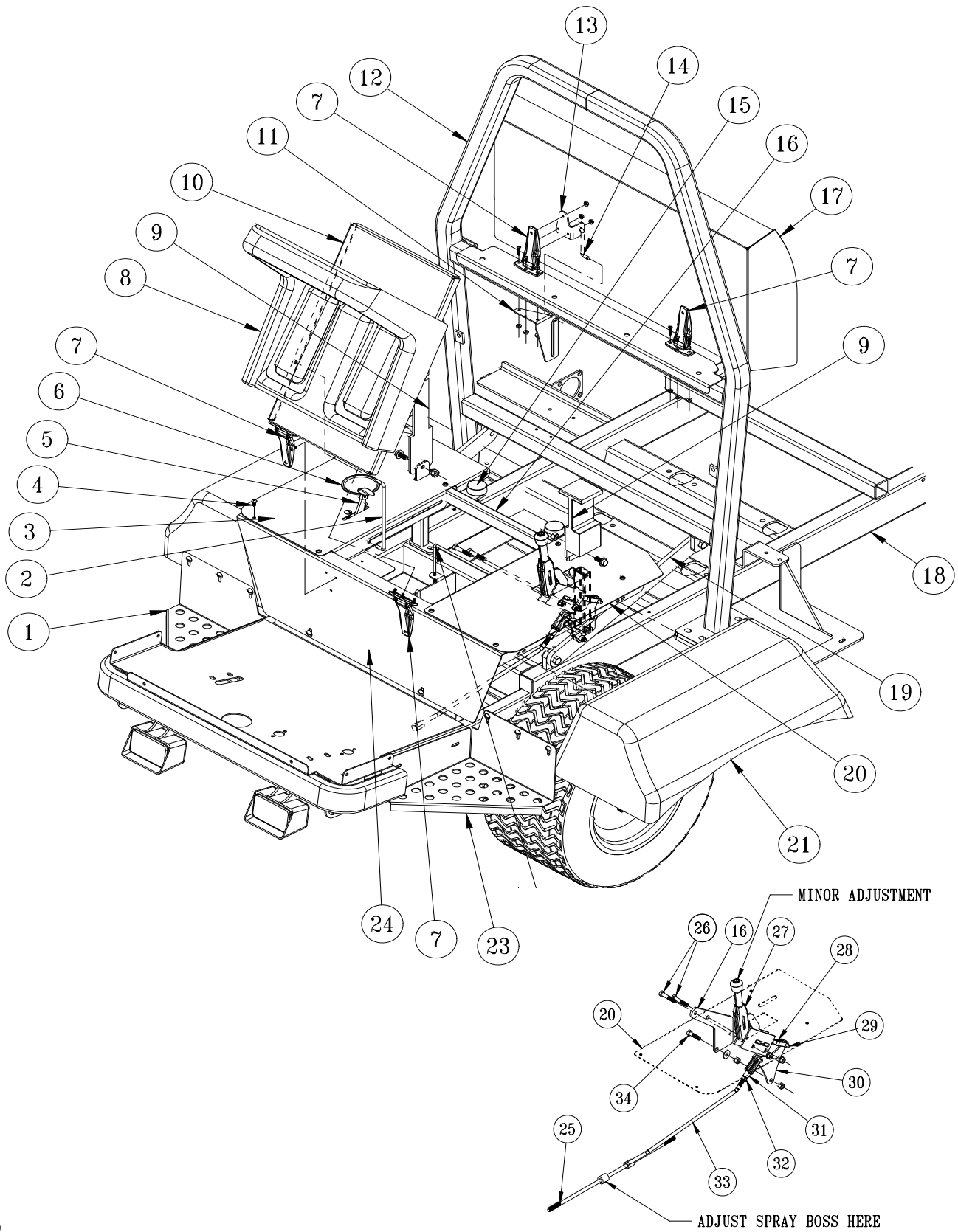

## SEAT PANEL PARTS LIST

REF#	PART#	DESCRIPTION	QUANTITY
22	30-074	Battery Holddown	1
	HNW-14-20	Wing Nut, 1/4 - 20	2
23	15-752	Step - LH	1
	HB-516-18-350	Hex Bolt, 5/16 - 18 x 3 1/2	2
	HNFL-516-18	Flange Lock Nut, 5/16 - 18	2
24	30-065	Front Panel	1
	HB-516-18-100	Hex Bolt, 5/16 - 18 x 1	2
	HNFL-516-18	Flange Lock Nut, 5/16 - 18	2
25	11-100	Linkage Yoke, 5/16 - 24	2
	34-021	Linkage Rod	1
	HN-516-24	Hex Nut, 5/16 - 24	2
26	60-106	Control Lever	1
27	HB-516-18-200	Hex Bolt, 5/16 - 18 x 2	2
	HNFL-516-18	Flange Lock Nut, 5/16 - 18	2
28	HB-38-16-100	Hex Bolt, 3/8 - 16 x 1	1
	HW-38	Flat Washer, 3/8	1
	HN-38-16	Hex Nut, 3/8 - 16	1
	HNFL-38-16	Flange Lock Nut, 3/8 - 16	1
29	30-047	Cruise Control Rod	1
30	HN-38-24	Hex Nut, 3/8 - 24	2
31	21-351	Linkage Yoke, 3/8 - 24	1
32	30-046	Cruise Relay	1
33	HCP-516-100	Clevis Pin, 5/16 x 1	1
	HP-18-075	Cotter Pin, 1/8 x 3/4	1

# ENGINE AND PUMPS DRAWING

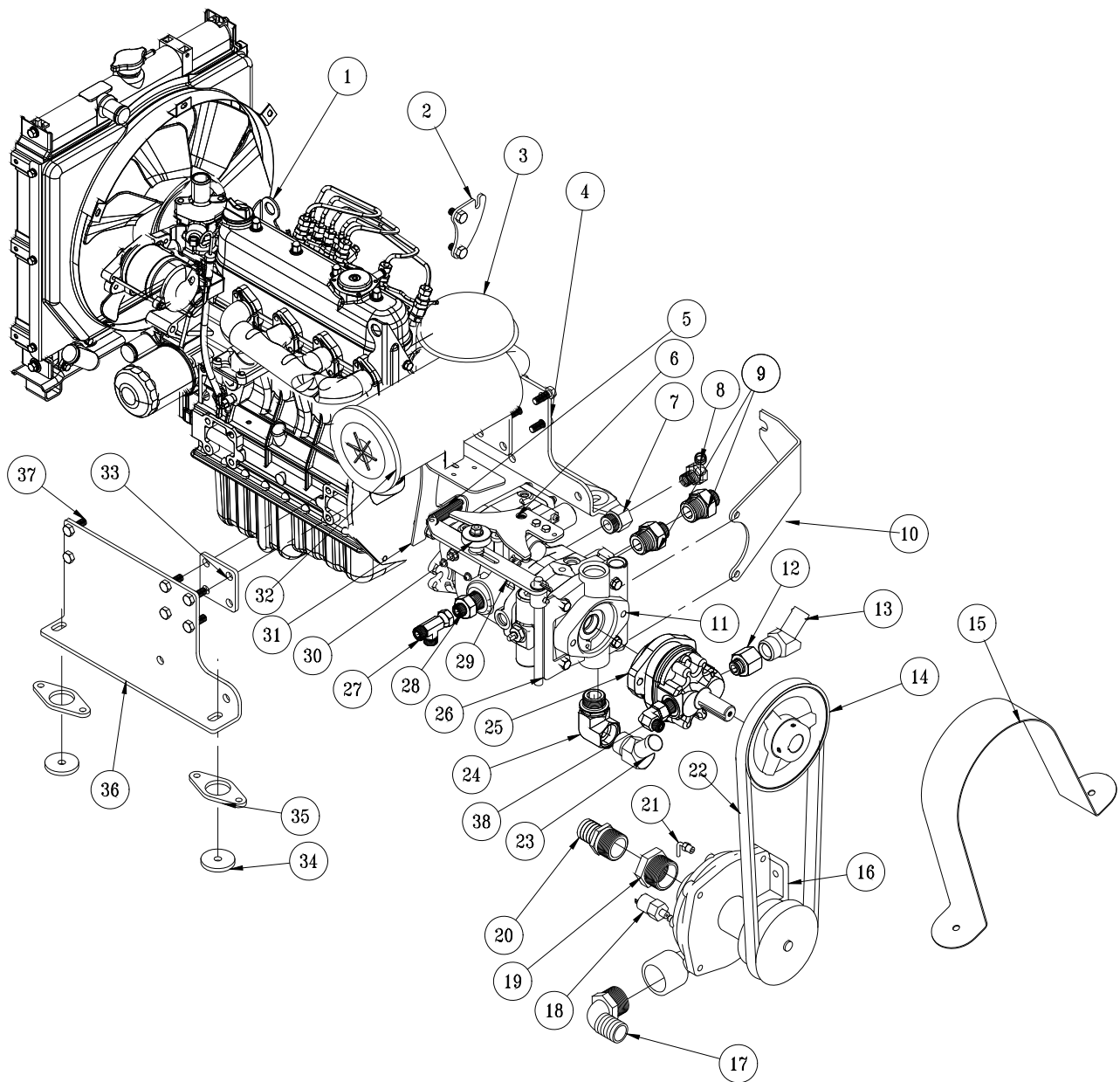

Parts



## ENGINE, AND PUMPS PARTS LIST

REF#	PART#	DESCRIPTION	QUANTITY
1	30-042	Kubota Diesel Engine 33.5 HP	1
	23-145	O'ring	1
2	30-033	Throttle Cable Mount	1
	HBM-10-1.5-20	Bolt #10 - 1.5 x 20	2
	HWLM-10	#10 Lock Washer	2
3	42-004-02	Air Cleaner Cap	1
4	30-041	Right Engine Mount	1
5	48-109	Spring	1
6	30-037	Shift Arm	1
	HB-14-20-075	Bolt 1/4 - 20 x 3/4	2
	HNCL-14-20	Center Lock Nut 1/4 - 20	2
7	18-333	Adapter	1
8	23-143	Connector	1
9	18-403	Adapter	2
10	30-031	Cable Mount	1
11	30-102	Eaton Closed Loop Pump	1
12	18-349	Straight Thread Reducer	1
13	23-190	45° Elbow 3/4 MPT	2
14	30-024	Pulley	1
15	30-067	Belt Guard	1
	HB-516-18-100	Bolt 5/16 - 18 x 1	2
	HNFL-516-18	Flange Lock Nut 5/16 - 18	2
16	16-998	Hypro Spray Pump	1
	30-058	Pump Mount	1
	HB-38-16-150	Bolt 3/8 - 16 x 1 1/2	2
	HNFL-38-16	Flange Lock Nut 3/8 - 16	2
17	16-156	Elbow 1 1/4 MPT x 1 1/4 HB	1
18	33-480	Pressure Switch	1
19	16-825	Hex Bushing	1
20	16-161	Hose Barb Fitting	1
21	33-494	Male Elbow	1
22	30-023	Belt	1
23	23-190	Elbow	1
24	23-191	Elbow	1
25	30-098	Gear Pump	1
	30-098-01	Seal Kit	1
26	30-029	Centering Arm Mount	1
29	30-082	Idler Arm	1
	HMB-12-14	Machine Bushing 1/2 - 14GA	
	HP-18-075	Cotter Pin 1/8 x 3/4	1
28	18-404	Adapter	1
27	18-405	Run Tee	1
30	14-266	Ball Bearing	1
	42-212	Shift Arm Spacer	1
	HB-38-16-200	Bolt 3/8 - 16 x 2	1
	HW-38	Washer 3/8	2
	HN-38-16	Nut 3/8 - 16	1
31	30-036	Timer Spring Mount	1
	HB-12-13-125	Bolt 1/2 - 13 x 1 1/2	1
	HWL-12	Lock Washer 1/2	1
32	30-042-02	Air Cleaner	1
	30-042-05	Element	1

# ENGINE AND PUMPS DRAWING

Parts

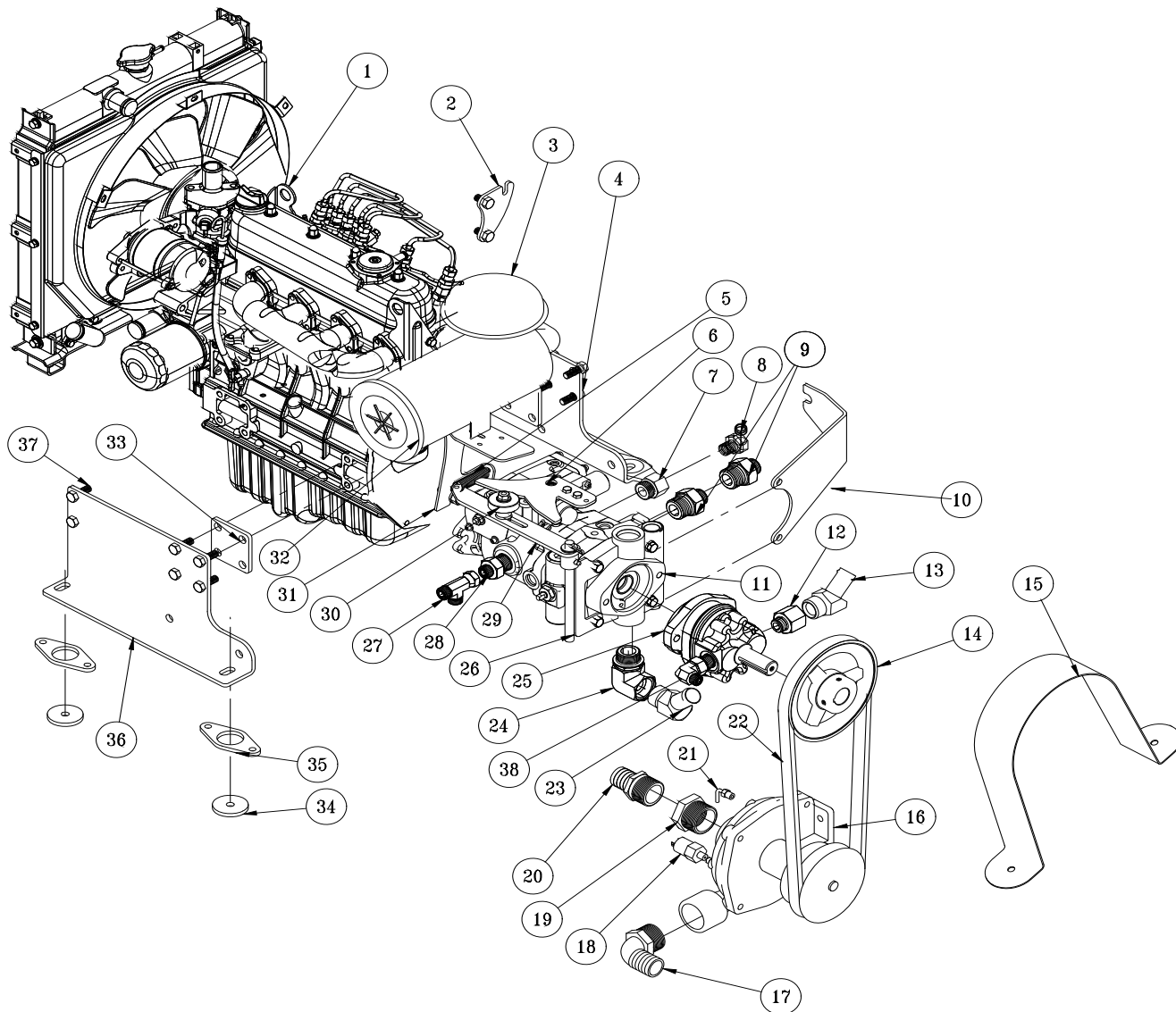

## ENGINE, AND PUMPS PARTS LIST

REF#	PART#	DESCRIPTION	QUANTITY
33	30-038	Kubota Spacer	2
34	30-064	Motor Washers	4
	HB-716-14-300	Bolt $7/16$ - 14 x 3	4
	HW-716	Washer $7/16$	4
	HNTL-716-14	Lock Nut $7/16$	4
35	30-042-01	Spacers	4
	HB-38-16-100	Bolt $3/8$ - 16 x 1	8
	HNFL-38-16	Flange Lock Nut $3/8$ - 16	8
36	30-040	Left Engine Mount	1
37	HBM-10-1.5-30	Bolt #10 - 1.5 x 30	12
	HWLM-10	#10 Lock Washer	12
38	18-350	$3/8$ Elbow	1

# COOLER AND EXHAUST DRAWING

Parts

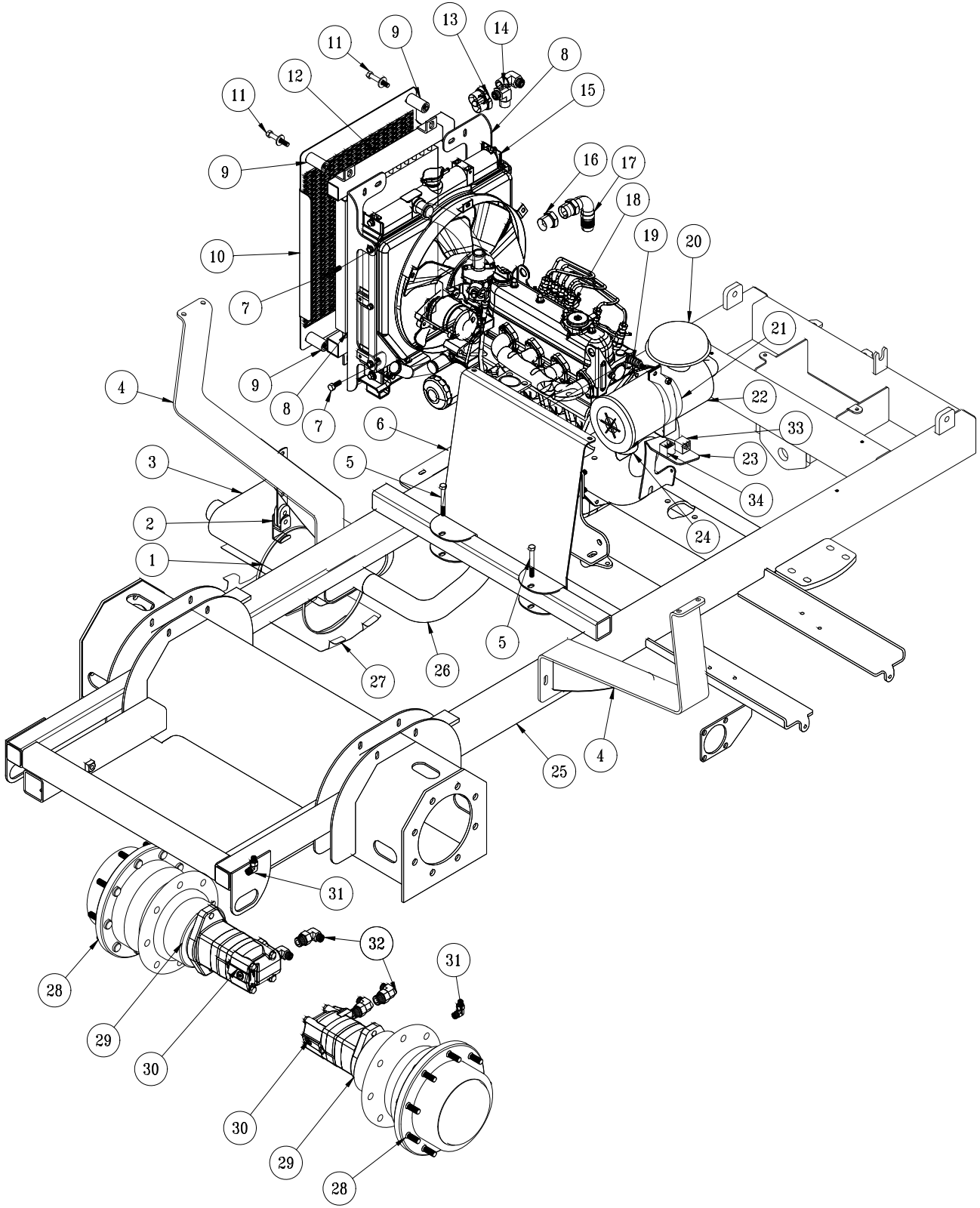

## COOLER AND EXHAUST PARTS LIST

REF#	PART#	DESCRIPTION	QUANTITY
1	30-118	Muffler Clamp	1
	42-216	Hose Clamp	2
	HB-14-20-125	Bolt $\frac{1}{4}$ - 20 x $\frac{1}{4}$	1
	HNFL-14-20	Flange Lock Nut $\frac{1}{4}$ - 20	1
2	33-159	Universal Exhaust Hanger	1
3	30-059	Muffler	1
4	30-052	Tank Carrier	2
5	HB-38-16-300	Bolt $\frac{3}{8}$ - 16 x 3	2
	HW-38	Washer $\frac{3}{8}$	2
	HNFL-38-16	Flange Lock Nut $\frac{3}{8}$ - 16	2
6	30-050	Front Tank Mount	1
7	HBM-6-1-16	Metric Bolt M6 - 1 - 16	4
	HWLM-6	Metric Washer M6	4
	HW-14	Washer $\frac{1}{4}$	4
8	30-028	Cooler Mount	2
9	60-406	Spacer	4
10	30-043	Oil Cooler Cover	1
11	HB-38-16-275	Bolt $\frac{3}{8}$ - 16 x $2\frac{3}{4}$	4
	HNFL-38-16	Flange Lock Nut $\frac{3}{8}$ - 16	4
12	30-105	Thermal Transfer Heat Exchanger	1
13	18-107	Pipe Thread Reducer	1
14	18-402	$\frac{3}{4}$ x 90° Hose Barb	1
15		Radiator	1
16	18-408	Tube End Reducer	1
17	18-397	90° Hose Barb	1
18	30-042	Kubota 33.5 HP Diesel Engine	1
19		Hardware	
20	42-004-02	Air Cleaner Cap	1
21	30-042-03	Clamp	1
22	30-042-02	Air Cleaner Body	1
	30-042-05	Element	1
	30-042-07	Inlet Hose	1
23	30-036	Timer/Spring Mount	1
24	30-042-04	Evacuator Valve	1
25	30-020	Main Frame	1
26	30-061	Exhaust Pipe	1
	30-084	Clamp	1
	77-217	Exhaust Manifold gasket	1
27	30-096	Heat Shield	1
28	30-099	Auburn Wheel Drive	2
29	30-100	Micro Spring Hydraulic Brakes	2
30	30-101	Eaton 2000 Series Hydraulic Motor	2
	30-101-11	Seal Kit	2
31	18-394	Elbow	2
32	18-301	Straight Thread Elbow	4
33	30-042-06	Relay (part of engine)	1
34	77-223	Timer (part of engine)	1



# TANK PARTSLIST

REF#	PART#	DESCRIPTION	QUANTITY
1	HB-38-16-200	Bolt $\frac{3}{8}$ - 16 X 2	4
	HW-38	Washer $\frac{3}{8}$	4
	HNTL-38-16	Lock Nut $\frac{3}{8}$ - 16	4
2	30-051	Rear Tank Mount	1
	8828-16	Foam Tape	1
3	HB-38-16-300	Bolt $\frac{3}{8}$ - 16 x 3	4
	HW-38	Washer $\frac{3}{8}$	4
	HNFL-38-16	Flange Lock Nut $\frac{3}{8}$ - 16	4
4	30-095	318 Gallon Tank (fiberglass)	1
5	16-945	Double Thread Fitting	2
6	16-162	Hex Plug 1" (Inside tank below air gap filler)	2
7	16-953	Hinged Lid Well	1
	16-169	Strainer Basket	1
8	14-365	Air Gap Filler	1
9	16-962	1" Coupler	1
10	16-961	1" Adapter	1
11	33-495	Bulkhead Fitting	3
12	18-009	Street Elbow	2
13	16-137	Brass Hose Barb	2
14	8902-28	Clear Flo Tubing	1
	30-019	Decal, Site Gauge	1
15	15-013	Rubber Bumper	2
	HNFL-14-20	Flange Lock Nut $\frac{1}{4}$ - 20	2
16	30-073	Hood Support	1
17	30-062	Rear Tank Support	2
18	30-052	Tank Carrier	2
	8828-26	Foam Tape	4
19	30-050	Front Tank Mount	1
	8828-16	Foam Tape	1
20	33-480	Pressure Switch	1
21	16-161	Fitting	2
22	16-825	Hex Bushing	1
23	33-494	Male Elbow	2
	8954-44	Clear Hose	1
	18-116	Hose Clamp	2
24	16-998	Hypro Pump	1
25	16-156	Elbow	3
26	16-851	Close Nipple	1
27	18-372	3-Way Valve	1
28	16-180	Quick Coupler Male	1
29	16-935	Quick Coupler Cap	1
30	HB-38-16-275	Bolt $\frac{3}{8}$ - 16 x $2\frac{3}{4}$	4
	HW-38	Washer $\frac{3}{8}$	4
	HNFL-38-16	Flange Lock Nut $\frac{3}{8}$ - 16	4
31	HB-38-16-100	Bolt $\frac{3}{8}$ - 16 x 1	4
	HW-38	Washer $\frac{3}{8}$	4
	HNFL-38-16	Flange Lock Nut $\frac{3}{8}$ - 16	4
32	30-020	Main Frame	1
33	30-034	Right Boom Holder	1
	30-035	Left Boom Holder	1
34	HB-38-16-150	Bolt $\frac{3}{8}$ - 16 x $1\frac{1}{2}$	4
	HW-38	Washer $\frac{3}{8}$	4
	HNFL-38-16	Flange Lock Nut $\frac{3}{8}$ - 16	4
35	16-194	Anti-Vortex Fitting	1
36	16-155	Elbow	1
37	16-150	Double Thread Fitting	1
38	33-496	Reducer Bushing	1

# TURBO-QUADAGITATOR DRAWING

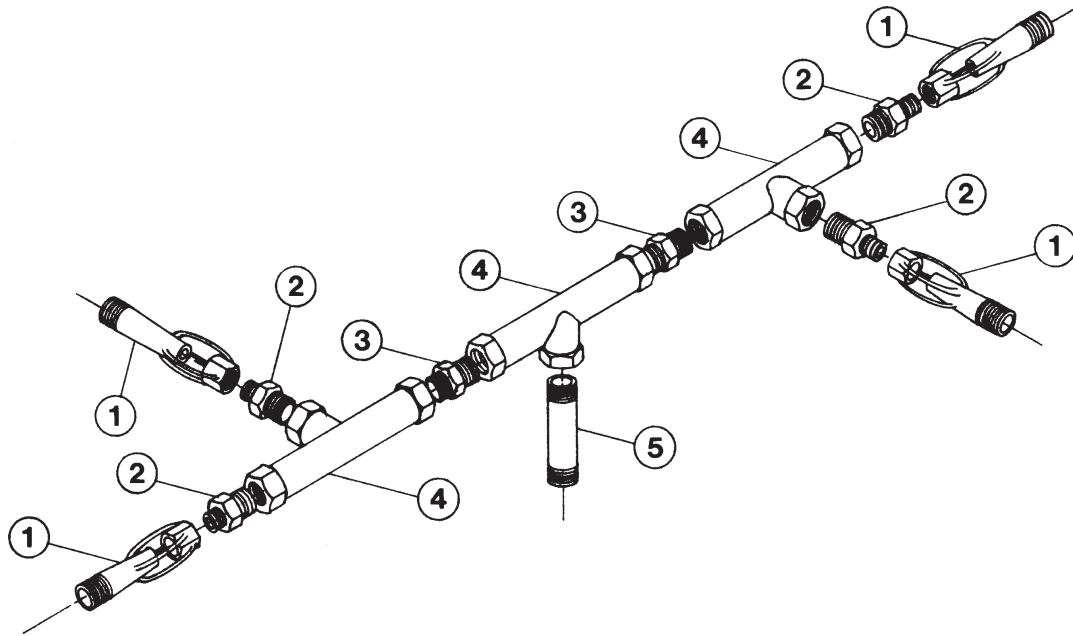

Parts



## TURBO-QUAD AGITATOR PARTS LIST

REF#	PART#	DESCRIPTION	QUANTITY
1	16-036	Agitator Jet (Includes one each $\frac{1}{8}$ ", $\frac{5}{53}$ ", and $\frac{3}{16}$ " orifices)	4
2	16-173	Reducer $\frac{3}{4}$ x $\frac{1}{2}$	4
3	16-158	Close Nipple $\frac{3}{4}$ x $\frac{3}{4}$	2
4	16-157	Female Pipe Thread Tee $\frac{3}{4}$ x $\frac{3}{4}$ x $\frac{3}{4}$	3
5	16-172	Nylon Nipple $\frac{3}{4}$ NPT x $3\frac{1}{2}$	1

15-301 ORBITROL DRAWING

Parts

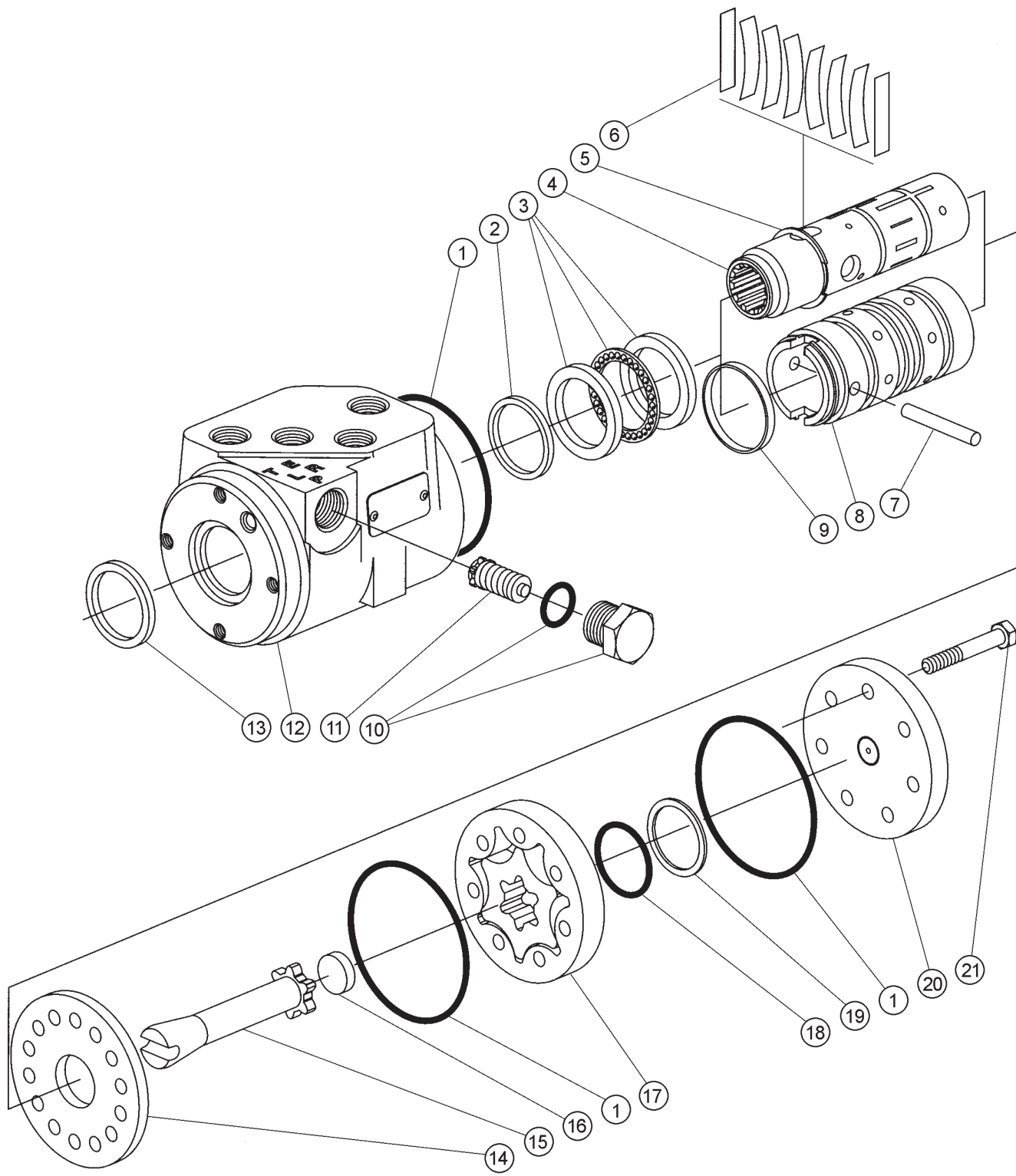

## 15-301 ORBITROL PARTS LIST

REF #	PART #	DESCRIPTION	QUANTITY
1*		O-Ring Seal	3
2*		Quad Seal	1
3	15-301-14	Bearing Kit	1
		Bearing Race	2
		Bearing	1
4		Spool	1
5	15-301-13	External Retaining Ring	1
6	15-301-15	Spring Centering Kit (Includes Ref# 9)	1
		Spring Spacer	2
		Centering Spring	6
		Spring Retaining Ring	1
7	15-301-08	Pin	1
8		Sleeve	1
9		Retainer	1
10	15-301-11	Plug and O-ring	1
*		O-Ring Seal	1
		Plug	1
11	15-301-12	Relief Valve/Check (1015 psi (70 bar))	1
12		Housing	1
13*		Dust Seal	1
14	15-301-06	Wear Plate	1
15	15-301-07	Drive	1
16	15-301-05	Spacer	1
17	15-301-04	Gerotor	1
18*		O-Ring	1
19*		Seal	1
20	15-301-03	End Cap	1
21	15-301-02	Cap Screw	7
*	15-301-01	Seal Kit	

### 15-301 ORBITROL SPECIFICATIONS

Maximum System Pressure	1015 psi (70 bar)
Maximum Back Pressure	150 psi (10 bar)
Maximum System Operating Temperature.	200°F (93°C)
Maximum Flow	4 gpm (15 lpm)
Maximum Temperature Differential between Steering Unit and System.	50°F (28°C)
Input Torque Powered	15-25 lb/in @ 100 psi tank pressure (2-3 Nm @ 7 bar)
Input Torque Maximum Non-powered	60 lb/ft (81 Nm)
Rotation Limits	None
Fluid	SAE 10W-40 API Service SJ or higher Motor Oil
Check Valve for Manual Steering	Yes
Relief Valve Setting	1015 psi (70 bar)
Ports	$\frac{9}{16}$ - 18 SAE O-Ring 4 Ports
Displacement	61 cu. in/ R (100 cu cm/R)



# 16-998 HYPRO<sup>®</sup> PUMP DRAWING

Parts

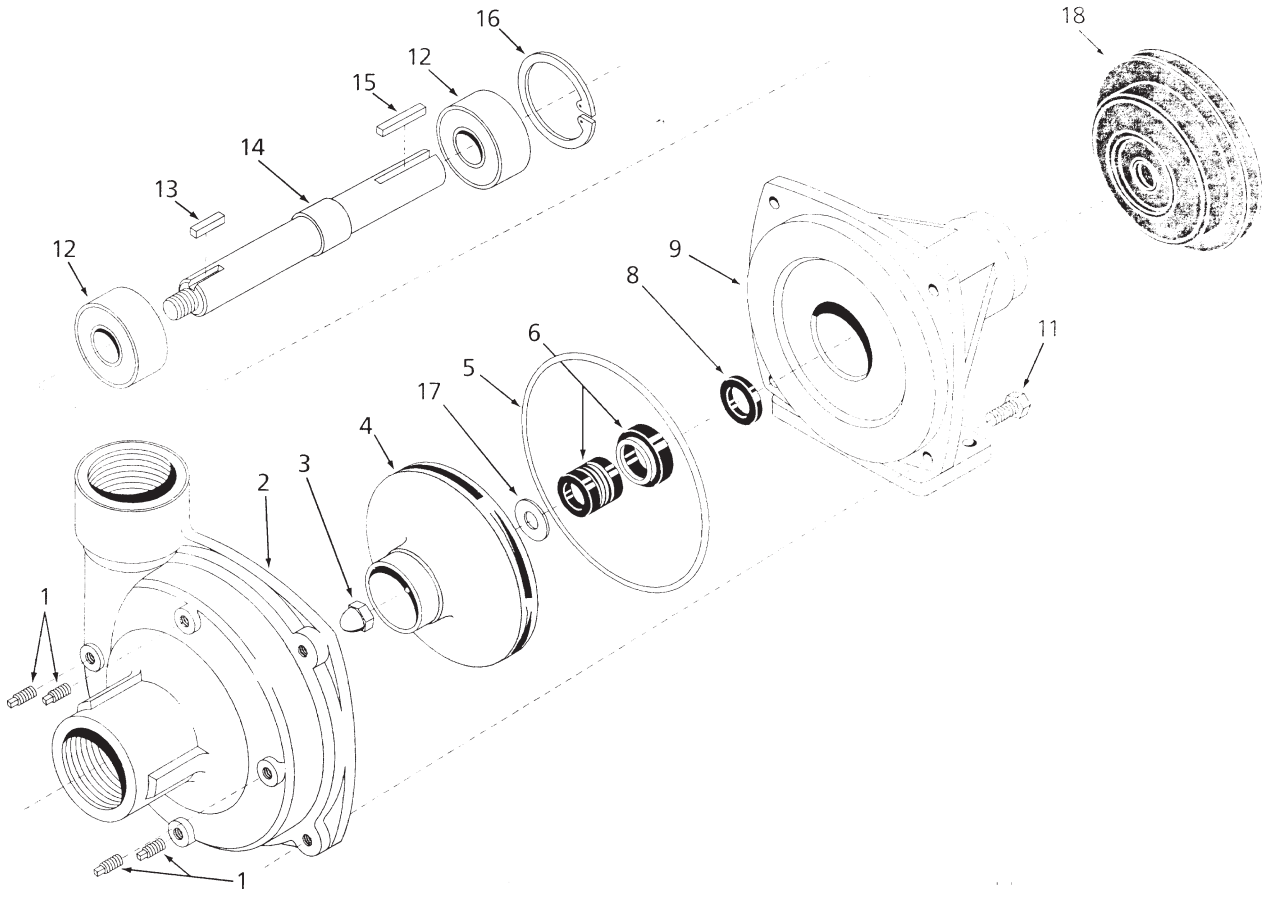

## 16-998 HYPRO® PUMP PARTS LIST

REF#	PART#	DESCRIPTION	QUANTITY
1	16-998-01	Drain Plug	4
2	16-998-02	Pump Casing	1
3	16-998-03	Impeller Nut	1
4	16-966-16	Impeller	1
5*	16-998-04	O-ring	1
6*	16-998-05	Mechanical Seal (Silicon Carbide)	1
8*	16-966-06	Slinger Ring	1
9	16-998-06	Mounting Flange	1
11	16-998-07	Bolt	4
12	16-966-10	Ball Bearing	2
13	16-998-08	Key	1
14	16-998-09	Pump Shaft	1
15	16-822-20	Key	1
16	16-966-13	Bearing Retainer	1
17*	16-998-10	Gasket	1
18	16-994-01	Clutch	1
*	16-967	Silicone - Carbon Seal Kit	

### **NOTE:**

When servicing the spray pump or filter, all control valves must be shut off if there is liquid in the tank.

# 30-102 EATON PUMP DRAWING

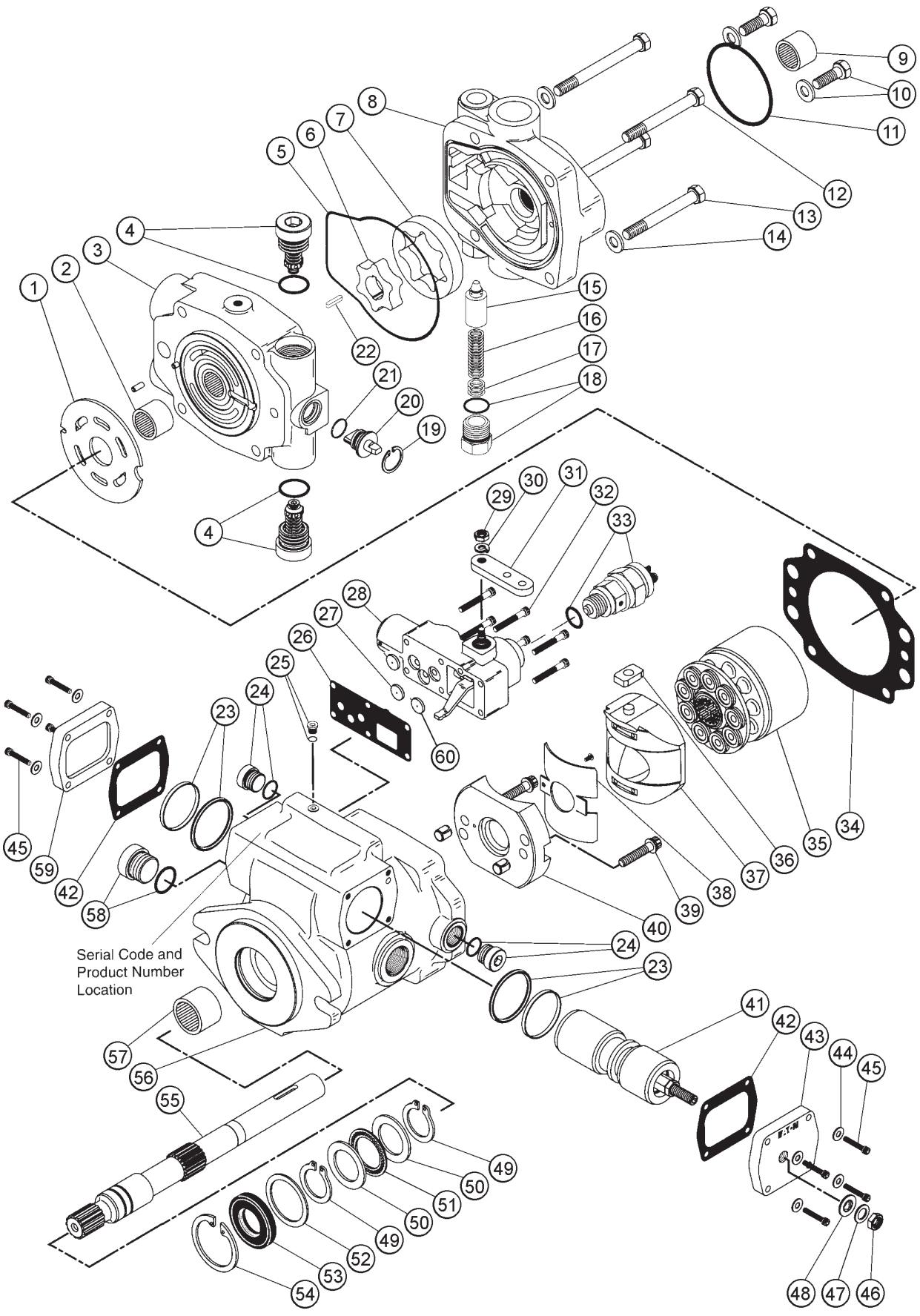

Serial Code and Product Number Location

Parts

## 30-102 EATON PUMP PARTS LIST

REF#	PART#	DESCRIPTION	QUANTITY
1	33-058-16	Valve Plate (CW Rotation)	1
2	33-058-26	Bearing (Press Fit)	1
3	33-058-25	Back Plate Assembly	1
4	33-058-12	Relief Valve S/A	2
*		O-Ring	2
5*		Molded O-Ring	1
6	33-058-38	Inner Ring Gerotor	1
7	33-058-39	Outer Ring Gerotor	1
8	33-058-35	Charge Pump Adapter Assembly	1
9	33-058-46	Bearing (Press Fit)	1
10		Bolt and Washer	2
11*		O-Ring	1
12	33-058-14	Cap Screw $\frac{3}{8}$ - 16 x 4	2
13	33-058-13	Cap Screw $\frac{3}{8}$ - 16 x $3\frac{1}{2}$	2
14	33-058-44	Washer	4
15	33-058-50	Poppet	1
16	33-058-49	Spring	1
17	33-058-48	Shims	As Required
18	33-058-47	Plug	1
*		O-Ring	1
19*		Retaining Ring	1
20	33-058-41	Dump Valve Actuator	1
21*		Quad-Ring	1
22	33-058-34	Key	1
23*		Seal Sub-Assembly	2
24	33-058-32	Plug S/A	2
*		O-Ring	2
25	33-058-19	Plug Sub-Assembly	1
*		O-Ring	1
26*		Control Housing Gasket	1
27	33-058-40	Control Valve Orifice	1
28	33-058-37	Servo Control Assembly	1
29	33-058-29	Nut	1
30	33-058-30	Lockwasher	1
31	33-058-36	Control Arm	1
32	33-058-15	Cap Screw	6
33	33-058-45	Interlock Switch	1
34*		Housing Gasket	1
35	33-058-04	Rotating Kit Assembly	1
36	33-058-06	Servo Piston Follower	1
37	33-058-09	Cam Plate S/A	1
38	33-058-22	Bushing	1
39	33-058-24	Cap Screw	2
40	33-058-20	Cradle Sub-Assembly	1
41	33-058-05	Servo Piston Assembly	1
42*		Cover Plate Gasket	2
43	33-058-08	Cover Plate	1
44	33-058-43	Washer	8
*	33-058-01	Seal Repair Kit	

(Continued on next page)

# 30-102 EATON PUMP DRAWING

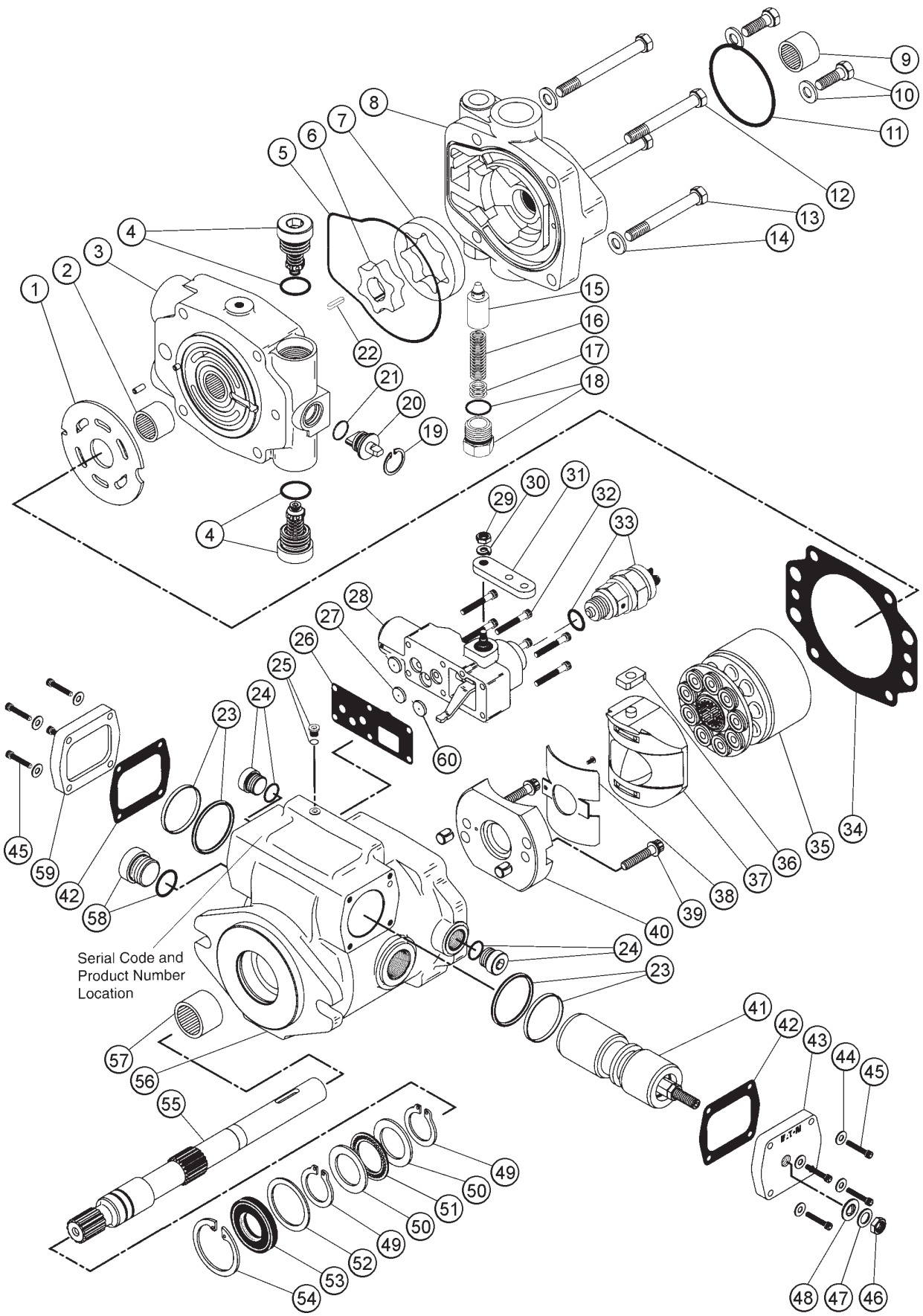

Serial Code and Product Number Location

Parts



## 30-102 EATON PUMP PARTS LIST

REF#	PART#	DESCRIPTION	QUANTITY
45	33-058-03	Cap Screw #10 - 24 x 1	8
46	33-058-02	Jam Nut	1
47	33-058-42	Washer	1
48*		Seal Washer	1
49*		Retaining Ring	2
50	33-058-10	Thrust Race	2
51	33-058-11	Thrust Bearing	1
52	33-058-31	Washer	1
53*	33-058-52	Shaft Seal	1
54*		Retaining Ring	1
55	33-058-28	Drive Shaft	1
56	33-058-17	Housing Assembly	1
57	33-058-18	Bearing (Press Fit)	1
58	33-058-33	Plug S/A	1
*		O-Ring	1
59	33-058-07	Cover Plate	1
60	33-058-51	Control Valve Orifice	2
*	33-058-01	Seal Repair Kit	

# 30-101 EATON MOTOR DRAWING

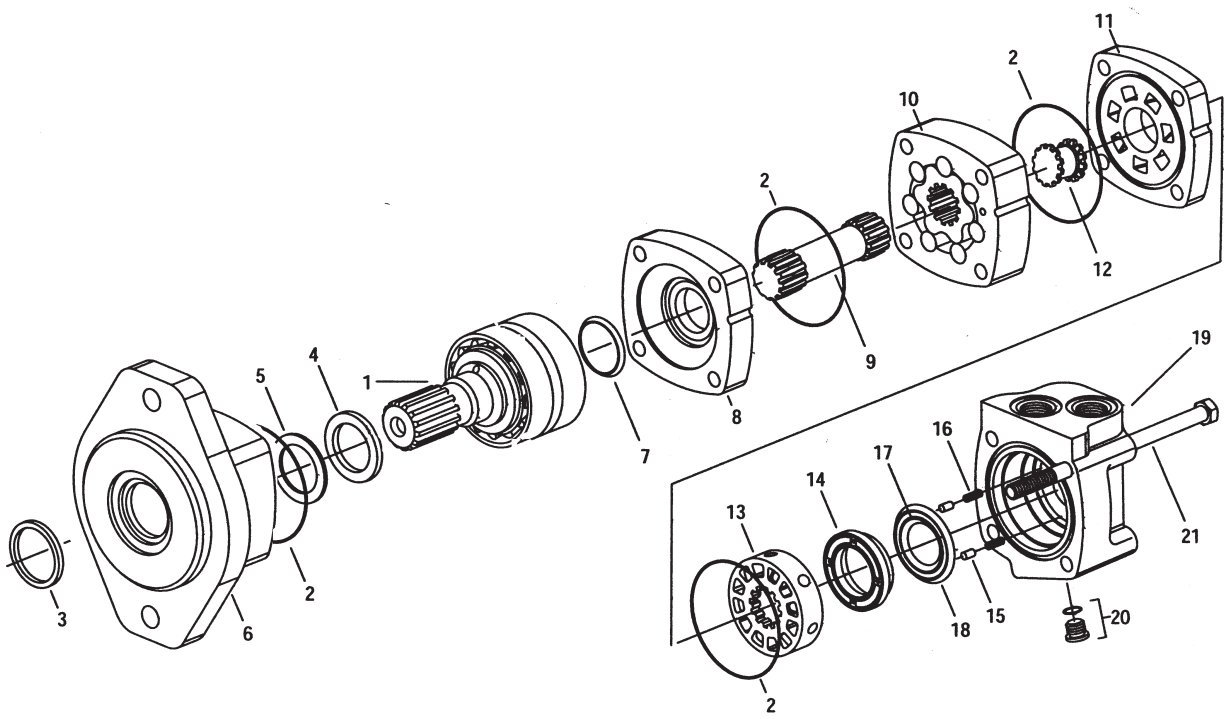

Parts

## 30-101 EATON MOTOR PARTS LIST

REF#	PART#	DESCRIPTION	QUANTITY
1	30-101-01	Shaft and Bearing Kit (7/8 splined 13T)	1
2*		Seal	4
3*		Exclusion Seal	1
4*		Shaft Seal	1
5*		Back Up Ring	1
6	30-101-02	Bearing Housing	1
7*		Shaft Face Seal	1
8	30-101-03	Wear Plate	1
9	30-101-04	Main Drive	1
10	30-101-05	Geroler	1
11	30-101-06	Valve Plate	1
12	14-207	Valve Drive	1
13	14-208	Valve	1
14	30-101-07	Balance Ring	1
15	14-210	Balance Ring Pin	2
16	14-209	Compression Spring	2
17*		Inner Face Seal	1
18*		Outer Face Seal	1
19	30-101-08	Valve Housing	1
20	30-101-09	Plug Assembly	1
*		O-ring	1
21	30-101-10	Cap Screw	4
*	30-101-11	Seal Kit	1 per

# 3182 PLUMBING DRAWING (RAVEN 440)

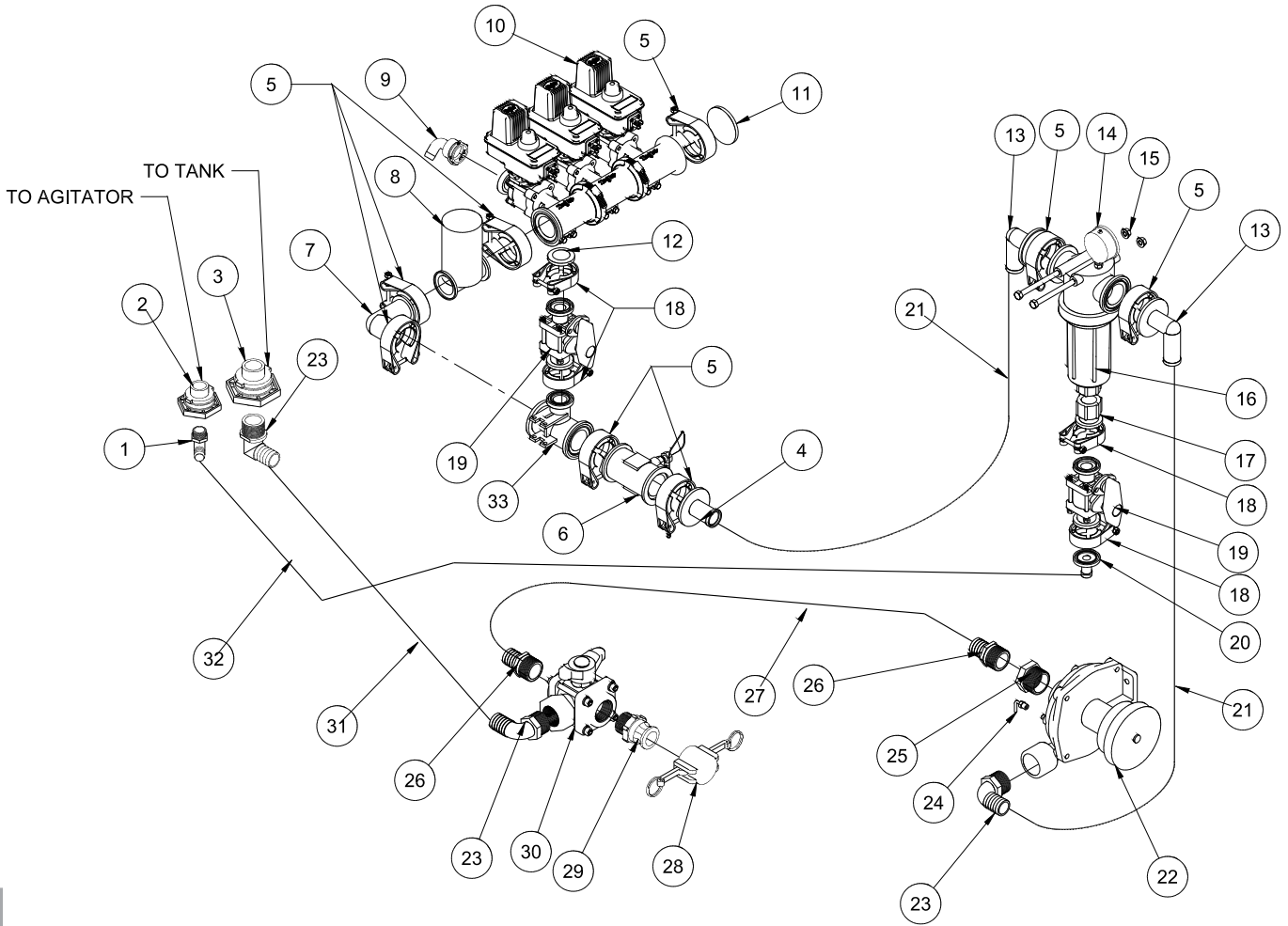

Accessories

## 3182 PLUMBING PARTS LIST (RAVEN 440)

REF#	PART#	DESCRIPTION	QUANTITY
1	16-155	Elbow	1
2	16-150	Double Threaded Fitting	1
3	16-194	Anti-Vortex Fitting	1
4	15-744	#75 1 <sup>1</sup> / <sub>4</sub> Hose Barb	1
5	15-741	#75 Series Clamp	8
6	18-373	Flow Meter	1
7	15-734	#75 Elbow Coupling	1
8	16-524	Motorized Control Valve	1
9	15-553	3/4 - 90° Hose Barb	3
	15-553-01	Clip	3
	15-553-02	O-ring	3
	8887-120	3/4" Orange PVC Hose 120" (left boom)	1
	8887-138	3/4" Orange PVC Hose 138" (right and center booms)	2
	18-040	Hose Clamps	6
10	15-743	Manifold Valve	1
11	15-742	#75 Inlet Cover	1
12	15-778	Blank Gauge Port Flange	1
13	15-739	#75 x 90° x 1 <sup>1</sup> / <sub>2</sub> Hose Barb	2
14	16-281	Liquid Filled Gauge	1
15	HB-38-16-500	Bolt 3/8 - 16 x 5	2
	HNFL-38-16	Flange Lock Nut 3/8 - 16	2
16	15-737	Flanged Strainer	1
	16-968-03	Screen (50 mesh)	1
17	15-735	#50 x 1 Female Pipe thread Fitting	1
18	15-740	#50 Series Clamp	4
19	15-738	Flanged Ball Valve	2
20	15-808	#50 x 1 Straight Hose Barb	1
21	8897-60	1 <sup>1</sup> / <sub>4</sub> " Discharge Hose 60"	2
	9021-65	Fire Sleeve	2
	18-116	Hose Clamp	4
22	16-998	Hypro Spray Pump	1
23	16-156	Elbow	3
24	33-494	Male Elbow	1
25	16-825	Hex Bushing	1
26	16-161	Fitting	2
27	8897-24	1 <sup>1</sup> / <sub>4</sub> " Discharge Hose 24"	1
	18-116	Hose Clamp	2
28	16-935	Quick Coupler Cap	1
29	16-180	Quick Coupler Male	1
30	18-372	3-Way Valve	1
31	8897-36	1 <sup>1</sup> / <sub>4</sub> " Discharge Hose 36"	1
	18-116	Hose Clamp	2
32	8896-66	1" Discharge Hose 66"	1
	18-222	Hose Clamp	2
33	15-775	Reducer Tee	1

# 3184 PLUMBING DRAWING (RAVEN 203)

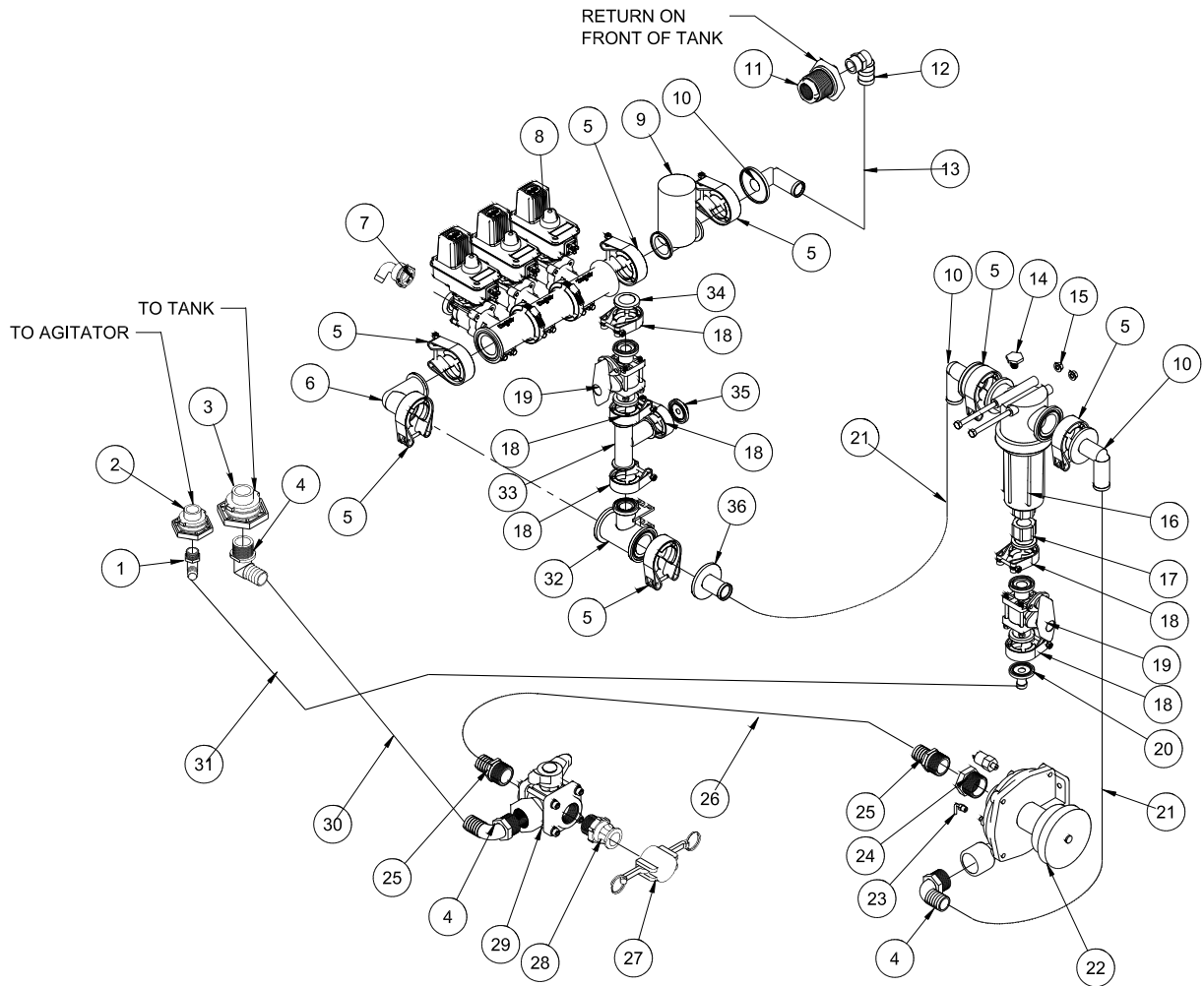

Accessories

## 3184 PLUMBING PARTS LIST (RAVEN 203)

REF#	PART#	DESCRIPTION	QUANTITY
1	16-155	Elbow	1
2	16-150	Double Threaded Fitting	1
3	16-194	Anti-Vortex Fitting	1
4	16-156	Elbow	3
5	15-741	#75 Series Clamp	7
6	15-734	#75 Elbow Coupling	1
7	15-553	3/4 - 90° Hose Barb	3
	15-553-01	Clip	3
	15-553-02	O-ring	3
	8887-120	3/4" Orange PVC Hose 120"	3
	18-040	Hose Clamps	6
8	15-743	Manifold Valve	1
9	16-524	Motorized Control Valve	1
10	15-739	#75 x 90° x 1 1/2 Hose Barb	3
11	16-945	Double Threaded Fitting	1
12	15-779	Hose Barb	1
13	8897-44	1 1/4" Discharge Hose 44"	1
	18-116	Hose Clamp	2
14	15-780	1/4" Poly Hex Plug	1
15	HB-38-16-500	Bolt 3/8 - 16 x 5	2
	HNFL-38-16	Flange Lock Nut 3/8 - 16	2
16	15-737	Flanged Strainer	1
	16-968-03	Screen (50 mesh)	1
17	15-735	#50 x 1 Female Pipe thread Fitting	1
18	15-740	#50 Series Clamp	4
19	15-738	Flanged Ball Valve	2
20	15-808	#50 x 1 Straight Hose Barb	1
21	8897-60	1 1/4" Discharge Hose 60"	2
	9021-65	Fire Sleeve	2
	18-116	Hose Clamp	4
22	16-998	Hypro Spray Pump	1
23	33-494	Male Elbow	1
	8954-30	Clear Hose	1
24	16-825	Hex Bushing	1
25	16-161	Fitting	2
26	8897-24	1 1/4" Discharge Hose 24"	1
	18-116	Hose Clamp	2
27	16-935	Quick Coupler Cap	1
28	16-180	Quick Coupler Male	1
29	18-372	3-Way Valve	1
30	8897-36	1 1/4" Discharge Hose 36"	1
	18-116	Hose Clamp	2
31	8896-55	1" Discharge Hose 55"	1
	18-222	Hose Clamp	2
32	15-775	Reducer Tee	1
33	15-776	#50 Series Tee	1
34	15-778	Blank Gauge Port Flange	1
35	15-777	Gauge Port Flange	1
36	15-744	#75 1 1/4 Hose Barb	1

# CONTROLS 3182 SYSTEM DRAWING (RAVEN 440)

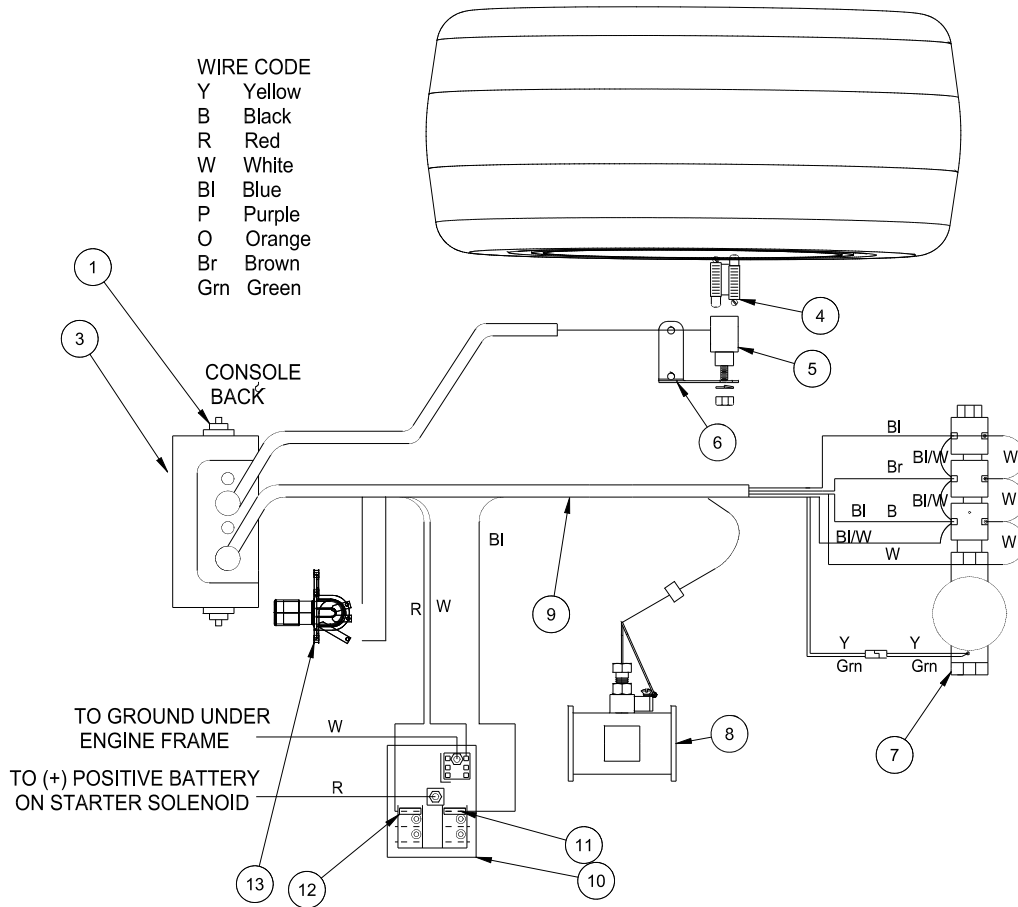

# CONTROLS 3184 SYSTEM DRAWING (RAVEN 203)

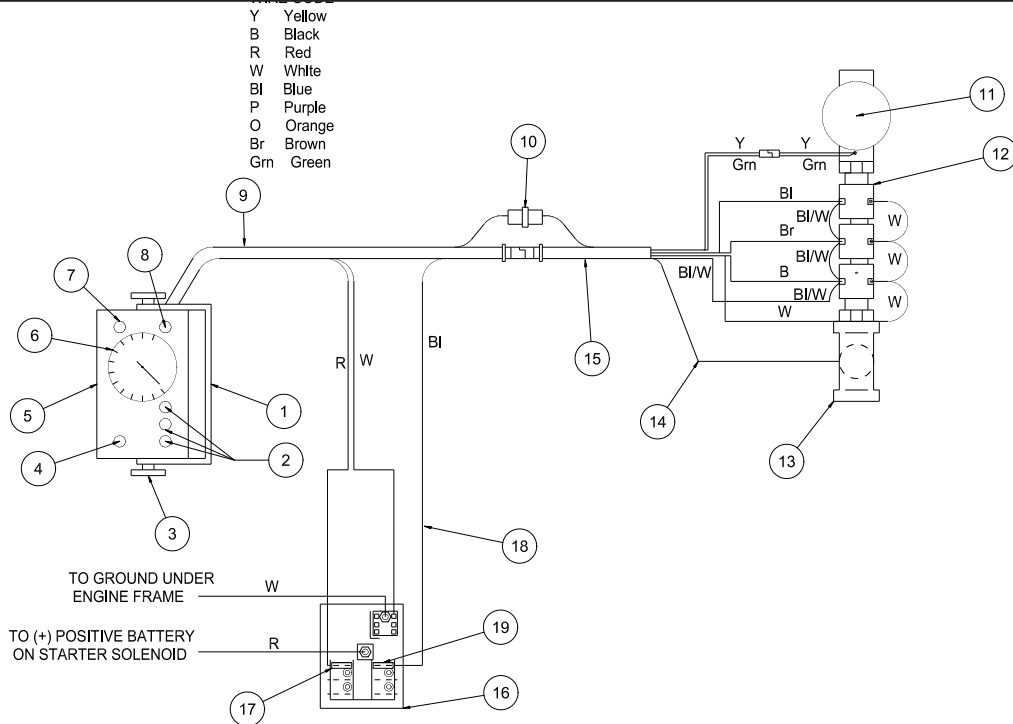

Accessories



## CONTROLS 3182 SYSTEM PARTS LIST

REF#	PART#	DESCRIPTION	QUANTITY
1	16-558	Mounting Knob	2
2	15-716	Controller Box	1
3	16-525	Console (only)	1
4	33-089-04	Red Magnet Assembly	1
	33-089-05	Black Magnet Assembly	1
5	16-139	Magnetic Sensor	1
	HN-14-20	Nut 1/4 - 20	2
	HWL-14	Lockwasher 1/4	2
6	15-715	Sensor Bracket	1
7	16-524	Motorized Control Valve	1
8	18-373	Flow Meter	1
9	15-369	Console Control Cable	1
10	33-271	Fuse Block	1
11	33-273	Auto Blade Type Fuse 30 amp	1
12	33-508	Auto Blade Type Fuse 15 amp	1
13	33-509	Master boom Switch	1

*Use Dielectric Grease On All Electrical Connections*

## CONTROLS 3184 SYSTEM PARTS LIST

REF#	PART#	DESCRIPTION	QUANTITY
1	16-958-01	Mounting Bracket	1
2	16-898	Boom Switch	3
3	16-900	Mounting Knob	2
4	16-899	Master Switch	1
5*	16-958	Console (only)	1
6	33-090-02	Liquid Filled Pressure Gauge	1
7	16-958-02	Fuse Holder	1
	16-525-03	Fuse 15 AMP	1
8	16-895	Pressure Switch	1
9*	16-958-04	Cable Assembly 8ft Enclosure Hook-Up	1
10*	16-958-05	Union Fitting	1
11*	15-624	Motorized Control Valve	1
12	15-743	Manifold Valve	1
13	15-775	Tee	1
14*	16-955	Tubing	1
15*	16-902	Cable Assembly 72" Solenoid Hook-Up	1
16	33-271	Fuse Block	1
17	33-508	Auto Blade Type Fuse 15 amp	1
18	10-225	Wire Harness (fuse block to electric valve)	1
19	33-273	Auto Blade Type Fuse 30 Amp	1
*	16-852	203 Sprayer Control Kit (includes all * items)	

*Use Dielectric Grease On All Electrical Connections*

# 15-743 MANIFOLD VALVE DRAWING

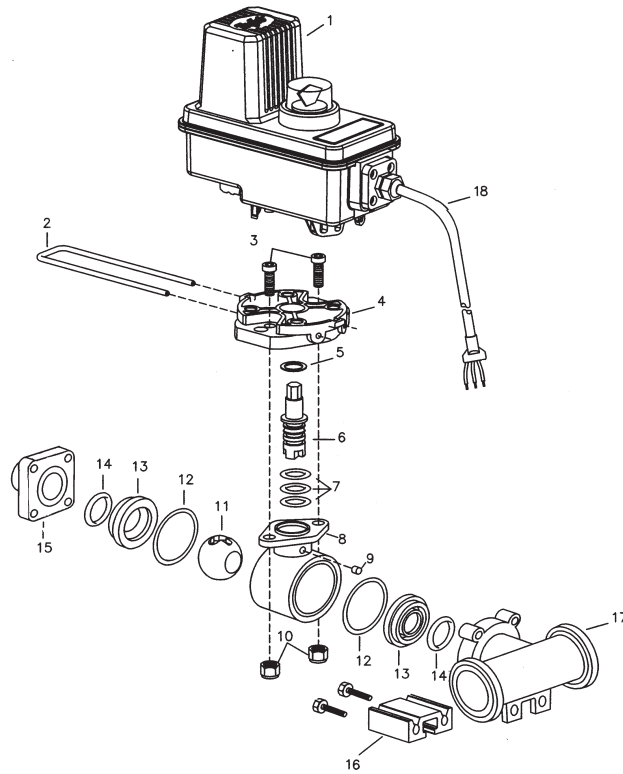

# 16-524 MOTORIZED CONTROL VALVE DRAWING

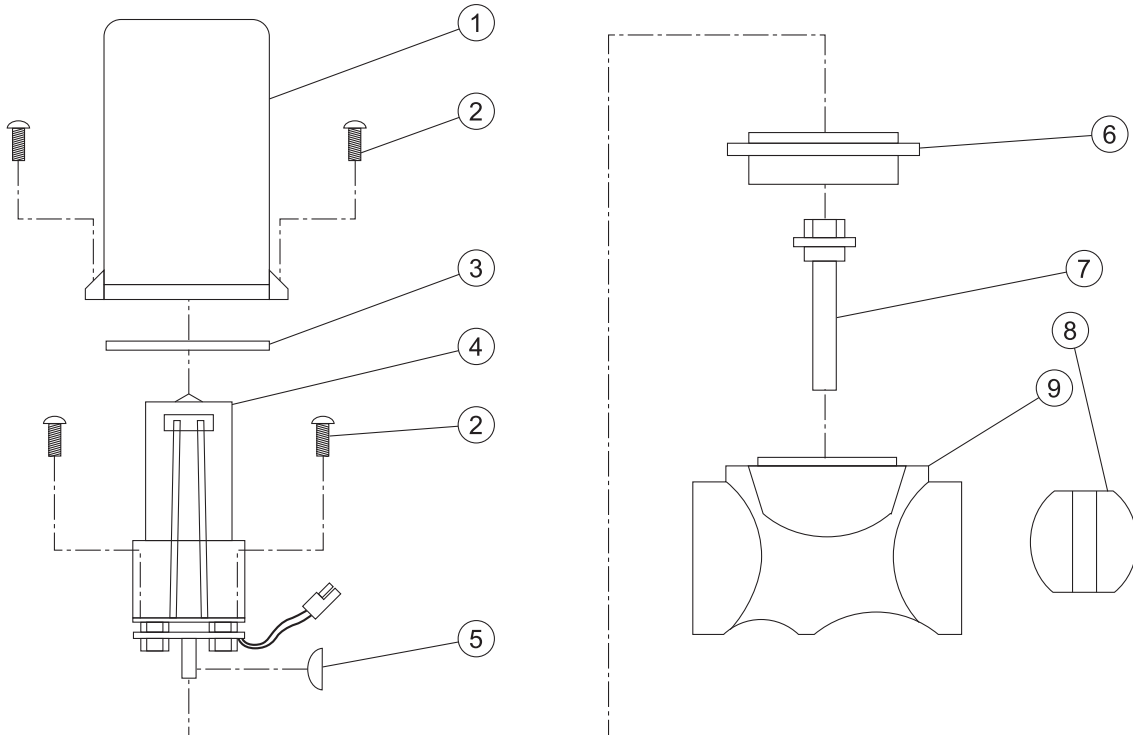

Accessories

## 15-743 MANIFOLD VALVE PARTS LIST

REF#	PART#	DESCRIPTION	QUANTITY
1	15-552-23	Motor	
2	15-552-24	Retaining Clip	1
3	15-552-25	Socket Head Cap Screw, Stainless Steel	2
4	15-552-26	Motor Adapter, Polypropylene	1
5*	15-517-11	Thrust Washer, Teflon	1
6	15-552-27	Stem, Stainless Steel	1
7*	15-552-05	O-ring, Viton	3
8	15-517-16	Body, Nylon	1
9*	15-517-17	Dust Plug, Felt	1
10		Lock Nut, Stainless Steel	2
11	15-552-09	Ball, Polypropylene	1
12*	15-552-13	Gasket, Viton	2
13*	15-517-19	Seal, teflon	2
14*	15-517-20	O-ring, Viton	2
15	15-743-01	End Cap	1
16	15-743-03	Mounting Rail aluminum	1
17	15-743-02	#75 tee Body	1
*	15-552-10	Spare Parts Kit (includes all * items)	

## 16-524 MOTORIZED CONTROL VALVE PARTS LIST

REF#	PART#	DESCRIPTION	QUANTITY
1	16-870	Valve Cover	1
2*	16-524-01	#6 Self Tapping Screw 3/4" Long	6
3	16-897	Seal Tetraseal	1
4	16-875	Motor Assembly (For 16-524 on Spray Star 3002)	1
4	16-866-01	Motor Assembly (For 16-866 on Spray Star 3004)	1
5*	16-957	Woodruff Key	1
6*	16-524-04	Isolation Flange Assembly	1
7*	16-524-02	Coupler Shaft	1
8*	16-956	Butterfly	1
9*	16-524-03	Valve Body Assembly (for 16-524)	1
	16-995-01	Valve Body Assembly (for 16-995)	1
10	16-995-01		
*	16-524-05	1" Valve ISO-Body Kit (for 15-524)	
	16-955-02	1" Valve ISO-Body Kit (for 16-995)	

**WHEN SERVICING VALVE:**

Replace valve body with ISO-Body Kit if valve has been leaking internally.

Replace motor assembly if the motor will not run or if the printed circuit board is corroded.

Before reassembling valve, remove the coupler shaft from the valve body. Apply Loctite to coupler shaft and woodruff key. Place the coupler shaft (Ref 7) and the woodruff key (Ref 5) onto the motor shaft. Plug motor into the valve connector coming from Sprayer Control Console. Check that the motor rotates in both directions. Motor must stop when coupler CAM releases printed circuit board switch button.

When reassembling valve, grease both sealing surfaces of coupler shaft. Insert coupler shaft into Iso-flange and be sure seal properly seats on shaft. Install on valve body and apply RTV 738 to mounting holes. Reassemble remaining items as shown in parts diagram on opposite side.



# 30-003 20' TERRAIN FOLLOWING BOOM DRAWING

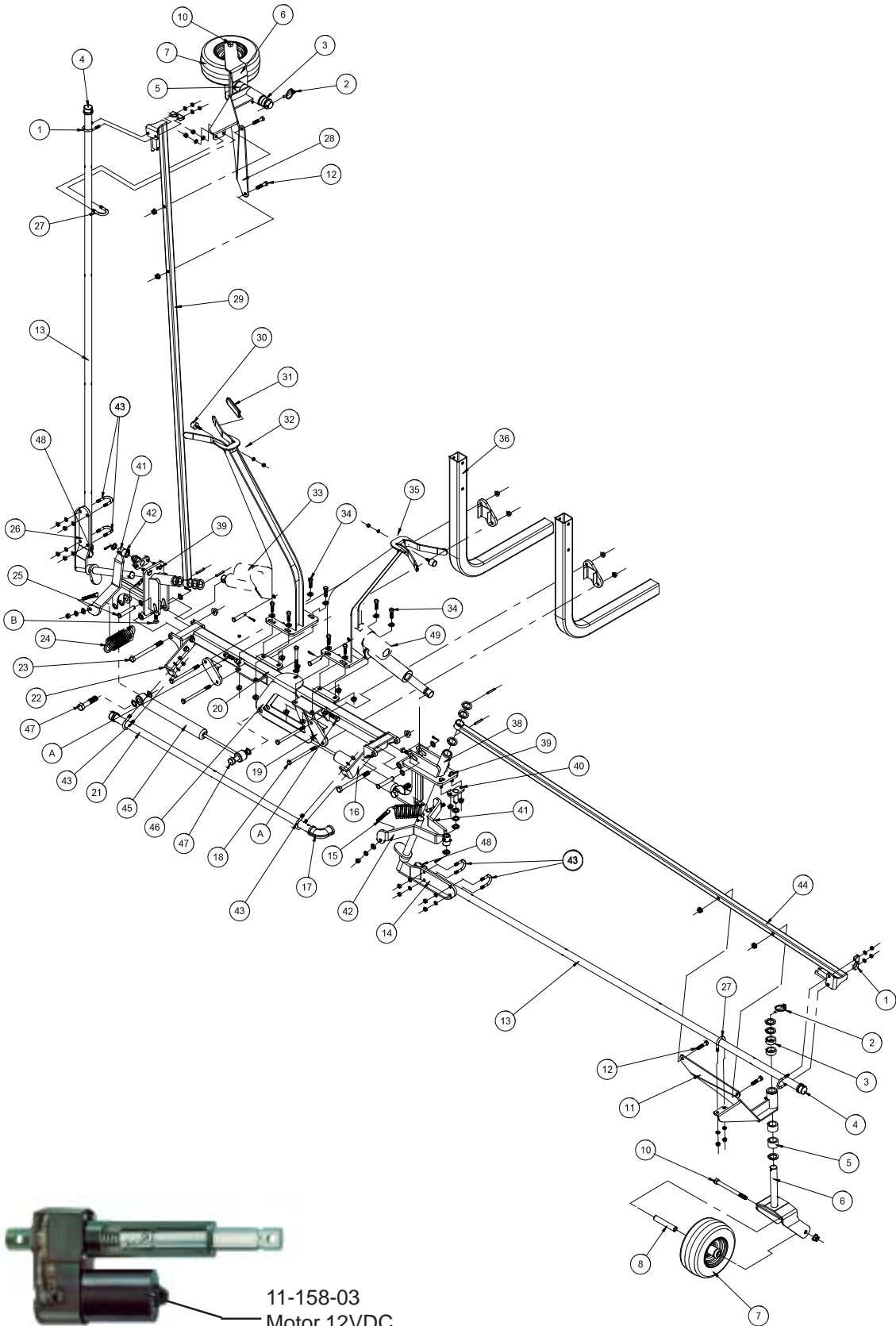

11-158-03  
Motor 12VDC

11-158 Linear Actuator

Accessories

## 30-003 20' TERRAIN FOLLOWING BOOM PARTS LIST

REF#	PART#	DESCRIPTION	QUANTITY
1	13-498	Muffler Clamp 1 <sup>1</sup> / <sub>8</sub>	2
	HWL-516	Lockwasher 5 <sup>5</sup> / <sub>16</sub>	4
	HN-516-18	Nut 5 <sup>5</sup> / <sub>16</sub> - 18 (part of 13-498)	4
2	42-539	Lynch Pin 1 <sup>1</sup> / <sub>4</sub>	2
3	29-584	1/2" Spacer	4
4	16-926	Stainless Steel Cap	3
5	29-585	1" Spacer	4
6	10-312	Castor Fork	2
	HMB-100-10	Machine Bushing 1 x 10GA (3 per fork)	6
7	42-202	Tire and Wheel	2
8	33-338	Axle Bearing	2
10	HBS-12-13-600	Stainless Steel Bolt 1/2 - 13 x 6	2
	HNTL-12-13	Lock Nut 1/2 - 13	2
11	10-310	Right Castor Wheel Bracket	1
	18-035	Bushing (part of 10-310)	2
	HG-14-28-180	Grease Fitting 1/4 - 28 x 180° (part of 10-310)	1
12	HBS-38-16-175	Stainless Steel Bolt 3/8 - 16 x 13/4	4
	HNTL-38-16	Lock Nut 3/8 - 16	4
13	16-928	Right and Left Tube	2
14	33-301	Right Pivot Bracket	1
	HMBS-100-10	Stainless Steel Machine Bushing 1 x 10GA	1
	HMBS-100-14	Stainless Steel Machine Bushing 1 x 14GA	2
	HRPS-14-150	Stainless Steel Roll Pin 1/4 x 1 1/2	2
	42-537	Spade Bolt 3/8 - 16	4
15	HW-38	Washer 3/8	4
	HWL-38	Lockwasher 3/8	4
	HN-38-16	Nut 3/8 - 16	4
	33-308	Right Center Tube Mount	1
	HBS-38-16-125	Stainless Steel Bolt 3/8 - 16 x 1 1/4	2
16	HWS-38	Stainless Steel Washer 3/8	2
	HNTL-38-16	Lock Nut 3/8 - 16	2
	16-925	Stainless Steel Pipe Elbow 3/4 x 90°	1
	18-249	Barb Fitting	1
17	18-040	Hose Clamp HS-12	1
	HBS-38-16-550	Stainless Steel Bolt 3/8 - 16 x 5 1/2	4
	HNTL-38-16	Lock Nut 3/8 - 16	4
19	10-304	Boom Bracket	4
20	30-108	Center Boom Mount	1
21	17-511	Center Tube	1
A	HSSQS-38-16-150	Stainless Steel Set Screw 3/8 - 16 x 1 1/2 (part of 30-108)	2
	HN-38-16	Nut 3/8 - 16 (part of 30-108)	2
22	33-309	Left Center Tube Mount	1
	HBS-38-16-125	Stainless Steel Bolt 3/8 - 16 x 1 1/4	2
	HWS-38	Stainless Steel Washer 3/8	2
	HNTL-38-16	Lock Nut 3/8 - 16	2
23	HBS-12-13-600	Stainless Steel Bolt 1/2 - 13 x 6	2
	HNTL-12-13	Lock Nut 1/2 - 13	2
24	10-313	Extension Spring	2
25	HCPS-12-275	Stainless Steel Clevis Pin 1/2 x 2 3/4	2
	HMB-12-14	Machine Bushing 1/2 x 14GA	4
	HPS-18-100	Stainless Steel Cotter Pin 1/8 x 1	2

(Continue on Next Page)

# 30-003 20' TERRAIN FOLLOWING BOOM DRAWING

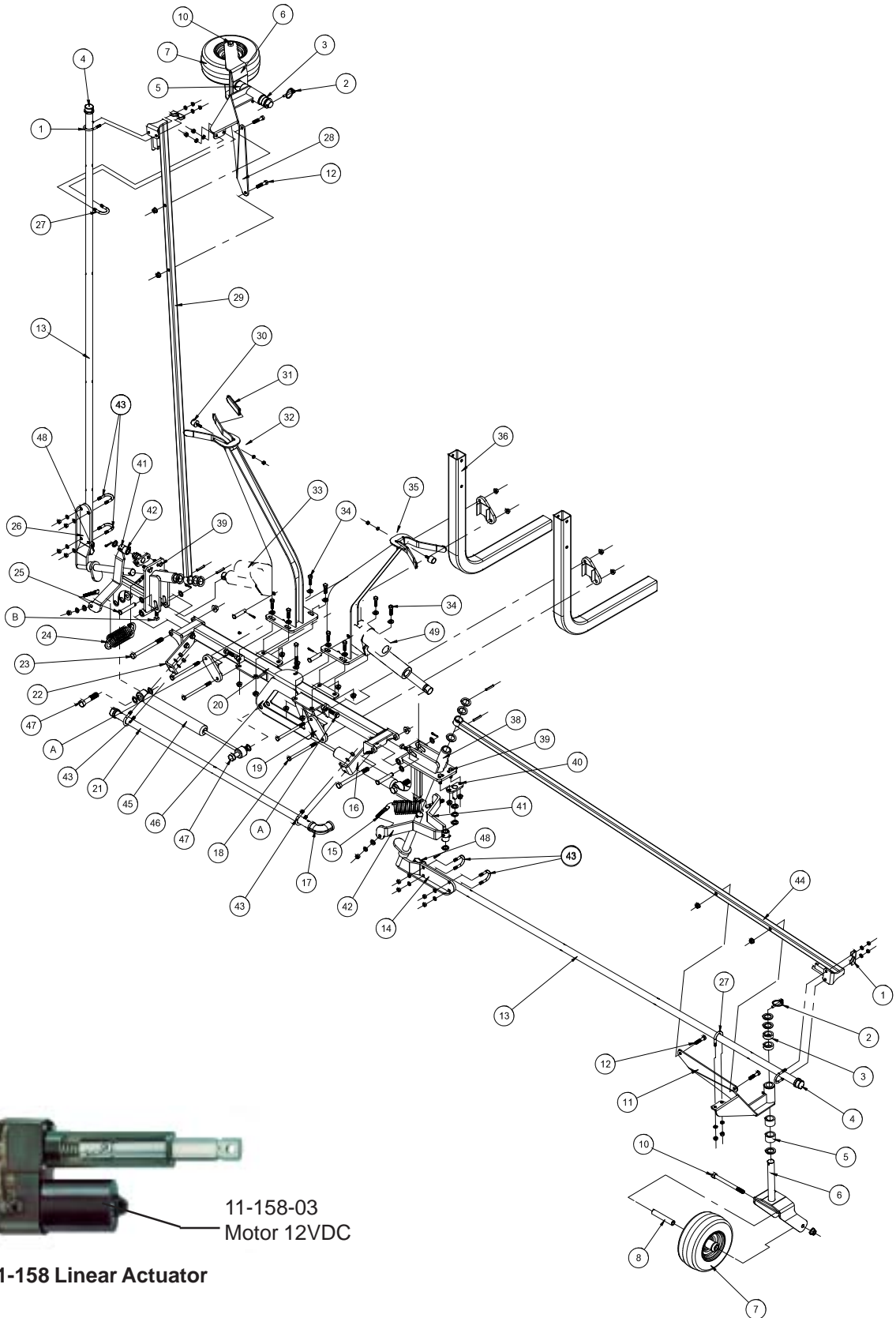

11-158-03  
Motor 12VDC

**11-158 Linear Actuator**

Accessories

## 30-003 20' TERRAIN FOLLOWING BOOM PARTS LIST

REF#	PART#	DESCRIPTION	QUANTITY
26	33-302	Left Pivot Bracket	1
	HMBS-100-10	Stainless Steel Machine Bushing 1 x 10GA	1
	HMBS-100-14	Stainless Steel Machine Bushing 1 x 14GA	2
	HRPS-14-150	Stainless Steel Roll Pin 1/4 x 1 1/2	2
27	16-024	U-Bolt 5/16 - 24	2
	HWLS-516	Stainless Steel Lockwasher 5/16	4
	HNS-516-24	Stainless Steel Nut 5/16 - 24	4
28	10-311	Left Castor Wheel Bracket	1
	18-035	Bushing (part of 10-311)	2
	HG-14-28-180	Grease Fitting 1/4 - 28 x 180° (part of 10-311)	1
29	10-307	Left Brush Guard	1
30	15-013	Rubber Bumper	2
	HWL-14	Lockwasher 1/4	2
	HN-14-20	Nut 1/4 - 20	2
31	10-318	Grip Pad	4
32	10-316	Left Boom Holder	1
33	11-180	Right-hand Linear Actuator	1
	HCPS-12-200	Stainless Steel Clevis Pin 1/2 x 2	1
	HPS-18-100	Stainless Steel Cotter Pin 1/8 x 1	1
34	HBS-38-16-125	Stainless Steel Bolt 3/8 - 16 x 1 1/4	8
	HWS-38	Stainless Steel Washer 3/8	8
	HNTL-38-16	Lock Nut 3/8 - 16	8
35	10-317	Right Boom Holder	1
36		Boom Carrier (part of machine)	
38	10-330	Pivot Bracket	2
	15-494	Nylon Flange Bushing 1" ID (2 per 10-330)	4
	18-036	Oilite Bushing 1/2 ID (2 per 10-330)	4
	HG-14-28-180	Grease Fitting 1/4 - 28 x 180° (2 per 10-330)	4
	HN-38-16	Nut 3/8 - 16 (1 per 10-330)	2
B	HSSQS-38-16-150	Stainless Steel Set Screw 3/8 - 16 x 1 1/2 (1 per 10-330)	2
39	HBS-38-16-125	Stainless Steel Bolt 3/8 - 16 x 1 1/4	4
	HWS-38	Stainless Steel Washer 3/8	4
	HNTL-38-16	Lock Nut 3/8 - 16	4
40	10-303	Pivot	2
	HMBS-58-14	Stainless Steel Machine Bushing 5/8 x 14GA	8
	HPS-18-100	Stainless Steel Cotter Pin 1/8 x 1	2
41	10-309	Left Cam Stop (must also order 10-308)	2
	18-268	Oilite Bushing (part of 10-309)	2
	HG-14-28-180	Grease Fitting 1/4 - 28 x 180° (part of 10-309)	2
42	10-308	Right Cam Stop (must also order 10-309)	2
	18-268	Oilite Bushing (part of 10-308)	2
	HG-14-28-180	Grease Fitting 1/4 - 28 x 180° (part of 10-308)	2
43	16-024	U-Bolt 5/16 - 24	6
	HWLS-516	Stainless Steel Lockwasher 5/16	12
	HNS-516-24	Stainless Steel Nut 5/16 - 24	12
44	10-306	Right Brush Guard	1
45	10-332	Stabilizer	2
46	10-331	Center Stabilizer Mount	1
	HB-38-16-300	Bolt 3/8 - 16 x 3	1
	HW-38	Washer 3/8	2
	HNTL-38-16	Lock Nut 3/8 - 16	1
47	HB-58-11-300	Bolt 5/8 - 11 x 3	4
	HMB-58-14	Machine Bushing 5/8 x 14GA	8
	HNTL-58-11	Lock Nut 5/8 - 11	4
48	18-411	Stainless Steel Pipe Elbow 3/4 x 45°	2
	18-249	Barb Fitting	2
	18-040	Hose Clamp HS-12	2
49	11-181	Left-hand Linear Actuator	1
	HCPS-12-200	Stainless Steel Clevis Pin 1/2 x 2	1
	HPS-18-100	Stainless Steel Cotter Pin 1/8 x 1	1





For best results use Teflon® Tape on all fittings.

1. The three boom assemblies are not on the packing list but are in carton. You can NOT order these boom assemblies as one unit. Please refer to parts drawing for individual parts. The long boom assemblies are the right and left booms. The labels are located on right and left pivot brackets (Ref 14 and 26). The small boom assembly is the center boom. Each assembly is shipped with the nozzle bodies (16-996). The remainder parts of the nozzles need to be installed.
2. Mount small boom assembly to the boom carriers on sprayer, using the four boom brackets (Ref 19), four  $\frac{3}{8}$  - 16 x 5 $\frac{1}{2}$  bolts and lock nuts (Ref 18). One boom bracket should go on boom assembly and one on boom carrier. Do the same for right and left side. Place boom at desired level (approximately 20" (51 cm) and be sure it is centered. Tighten bolts.
3. Put the boom holders (Ref 32 and 35) on the center mount (Ref 20) using  $\frac{3}{8}$  - 16 x 1 $\frac{1}{4}$  bolts, washers and lock nuts (Ref 34), with washers next to slots. Center the bolts in the slots and tighten. The set screws (Ref A) on the center mount should be tightened to the stop. It is used to set the up and down movement of the boom at the castor wheel. **The range of the boom is approximately 32" total (16" up and 16" down).** This can be adjusted by moving the boom holders. In will increase the up range. Out will increase the down range.
4. Take right boom and slide pivot bracket (Ref 38) in the center mount (Ref 20) and hold in place with  $\frac{1}{2}$  - 13 x 6 bolt and lock nut (Ref 23). Do not over tighten, boom must be able to move up and down. Repeat for left boom. You may need to loosen the pivot (Ref 40) to install  $\frac{1}{2}$  - 13 x 6 bolt due to interference with the cam stops (Ref 41 and 42).
5. Mount the actuator (Ref 33) with the fixed end to the right and left boom holders (Ref 35 and 32) using  $\frac{1}{2}$  x 2 clevis pin and cotter pin. Mount the ram end to the pivot brackets (Ref 38) using  $\frac{1}{2}$  x 2 $\frac{3}{4}$  clevis pin and cotter pin (Ref 25) with the  $\frac{1}{2}$  x 14GA machine bushing on the outside of the pivot brackets.
6. Hook hoses to the respective fittings using hose clamps (18-040). The hose coming from the right side of the sprayer goes to the straight fitting on the right boom. The center hose from the sprayer goes to the straight fitting on the center boom. The left hose from the sprayer goes to the straight fitting on the left boom. Be sure all hose clamps are tight.
7. Now install the wiring harness. Refer to the wiring diagram.
8. Lower the booms so that the ends are at a height that you can work at.
9. Put the left castor wheel bracket (Ref 28) onto the left boom as shown. Using two  $\frac{3}{8}$  - 16 x 1 $\frac{3}{4}$  bolts and lock nuts (Ref 12) and one u-bolt, two  $\frac{5}{16}$  stainless steel lockwashers and stainless steel  $\frac{5}{16}$  - 24 nuts (Ref 27). Repeat for the right boom with the right castor wheel bracket (Ref 11) using the same hardware.
10. Put the assembled castor forks into the castor wheel brackets, adjusting the spacers to get the boom height you desire.
11. Make certain set screws (Ref B) on both sides are completely screwed in. Raise booms with boom switches all the way up. Adjust set screws (Ref B) so they contact the stop and lock.
12. Install center stabilizer mount (Ref 45) onto center boom (Ref 20) with the  $\frac{3}{8}$  - 16 x 3 bolt, washers and lock nuts.
13. Place stabilizers (Ref 46) into pivot brackets (Ref 38) with  $\frac{5}{8}$  - 11 x 3 bolts, machine bushings and lock nuts (Ref 47). Place rod end of stabilizers into center stabilizer mount. Make sure all bolts are tight.



**BOOMS WILL NOT FOLD FORWARD!!  
SPRINGS CAN BE DAMAGED.**

# 17-503 20' SPRAY BOOM DRAWING

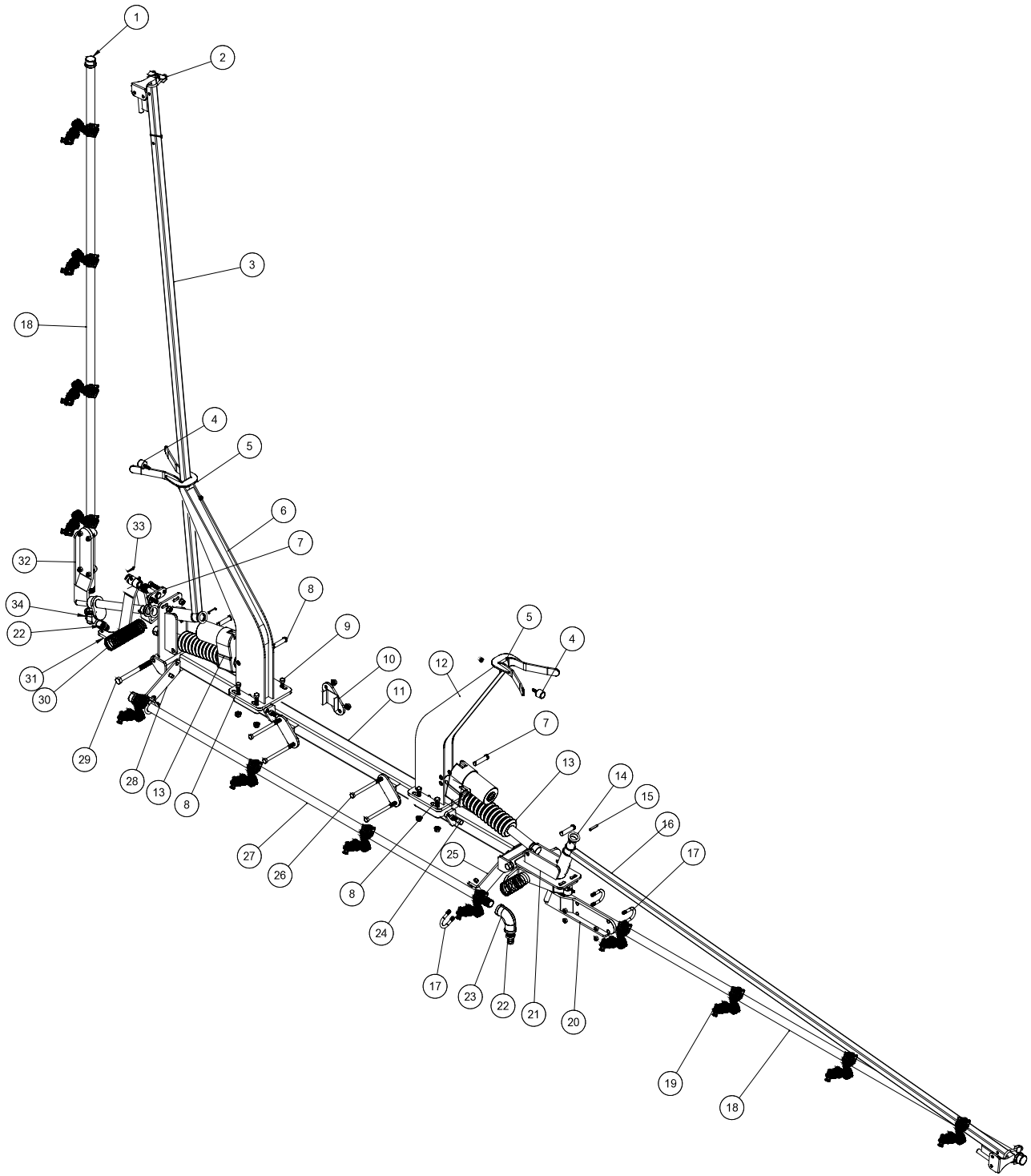

Accessories

## 17-503 20' SPRAY BOOM PARTS LIST

REF#	PART#	DESCRIPTION	QUANTITY
1	16-926	Stainless Steel Cap $\frac{3}{4}$	3
2	13-498	U-Bolt Kit $1\frac{1}{8}$	2
3	33-333	Left Brush Guard	1
4	15-013	Rubber Bumper	2
	HNFL-14-20	Flange Lock Nut $\frac{1}{4}$ - 20	2
5	15-020	Grip Pad	4
6	10-316	LH Boom Holder	1
7	15-810	Pivot	2
	HMB-58-14	Machine Bushing $\frac{5}{8}$ - 14	8
	HBS-38-16-125	Stainless Steel Bolt $\frac{3}{8}$ - 16 x $1\frac{1}{4}$	4
	HWS-38	Stainless Steel Washer $\frac{3}{8}$	4
	HNTL-38-16	Lock Nut $\frac{3}{8}$ - 16	4
8	HCPS-12-225	Stainless Steel Clevis Pin $\frac{1}{2}$ x $2\frac{1}{4}$	4
	HPS-18-100	Stainless Steel Cotter Pin $\frac{1}{8}$ x 1	4
9	HB-38-16-225	Bolt $\frac{3}{8}$ - 16 x $2\frac{1}{4}$	8
	HNTL-38-16	Lock Nut $\frac{3}{8}$ - 16	8
10	16-761	Boom Brackets	4
11	17-512	Center Mount	1
12	10-317	RH Boom Holder	1
13	11-180	Right-hand Linear Actuator with 4" Stroke	1
14	HMB-100-14	Machine Bushing 1 x 14GA	4
15	HRPS-14-150	Stainless Steel Roll Pin $\frac{1}{4}$ x $1\frac{1}{2}$	4
16	33-332	Right Brush Guard	1
17	16-024	U-Bolt $\frac{5}{16}$ - 24	6
	HWLS-516	Stainless Steel Lockwasher $\frac{5}{16}$	12
	HNS-516-24	Stainless Steel Nut $\frac{5}{16}$ - 24	12
18	16-928	Right and Left Tube	2
19	16-996	Nozzle Bodies	12
20	33-301	Right Pivot Bracket	1
21	15-813	Pivot Bracket	2
	15-494	Nylon Flange Bushing (part of 33-295)	4
	18-036	Oilite Bushing (part of 33-295)	4
	HSSQS-38-16-150	Stainless Steel Set Screw $\frac{3}{8}$ - 16 x $1\frac{1}{2}$	2
	HN-38-16	Nut $\frac{3}{8}$ - 16	2
22	18-249	Barb Fitting	3
23	16-925	Stainless Steel Pipe Elbow $\frac{3}{4}$ x 90°	1
24	HSSQS-38-16-150	Stainless Steel Set Screw $\frac{3}{8}$ - 16 x $1\frac{1}{2}$ (part of 17-512)	2
	HN-38-16	Nut $\frac{3}{8}$ - 16 (part of 17-512)	2
25	33-308	Right Center Tube Bracket	1
	HBS-38-16-125	Stainless Steel Bolt $\frac{3}{8}$ - 16 x $1\frac{1}{4}$	2
	HWS-38	Stainless Steel Washer $\frac{3}{8}$	2
	HNTL-38-16	Lock Nut $\frac{3}{8}$ - 16	2
26	HBS-38-16-550	Stainless Steel Bolt $\frac{3}{8}$ - 16 x $5\frac{1}{2}$	4
	HNTL-38-16	Lock Nut $\frac{3}{8}$ - 16	4
27	17-511	Center Tube	1
28	33-309	Left Center Tube Bracket	1
	HBS-38-16-125	Stainless Steel Bolt $\frac{3}{8}$ - 16 x $1\frac{1}{4}$	2
	HWS-38	Stainless Steel Washer $\frac{3}{8}$	2
	HNTL-38-16	Lock Nut $\frac{3}{8}$ - 16	2

(Continued on next page)

# 17-503 20' SPRAY BOOM DRAWING

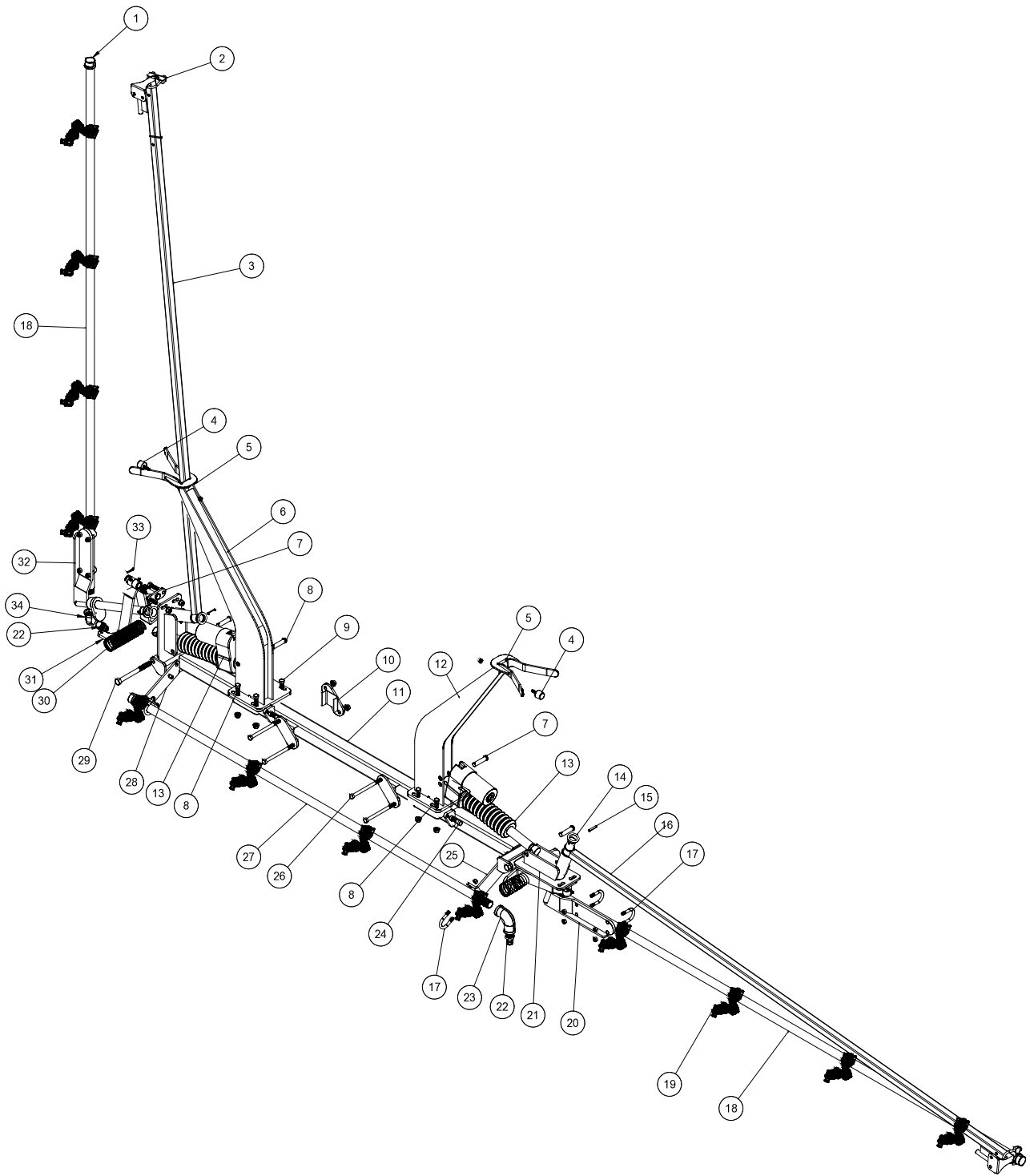

Accessories

## 17-503 20' SPRAY BOOM PARTS LIST

REF#	PART#	DESCRIPTION	QUANTITY
29	HBS-12-13-550	Stainless Steel Bolt $\frac{1}{2}$ - 13 x $5\frac{1}{2}$	2
	HNCL-12-13	Center Lock Nut $\frac{1}{2}$ - 13	2
30	15-495	Extension Spring	2
31	15-812	Right Cam Stop (must also order 15-811)	2
	15-811	Left Cam Stop (must also order 15-812)	2
	18-268	Oilite Bushing (part of 15-812)	2
	HMB-100-10	Machine Bushing 1 x 10GA	2
32	33-302	Left Pivot Bracket	1
33	HPS-18-100	Cotter Pin $\frac{3}{8}$ x 1	2
34	18-411	Stainless Steel Pipe Elbow $\frac{3}{4}$ x 45°	2
35	11-180	Right-hand Linear Actuator with 4" Stroke	1

## INSTALLATION INSTRUCTION

For best results use Teflon<sup>®</sup> tape on all fittings.

1. The three boom assemblies are not on the packing list but are in carton. The long boom assemblies are the right and left booms. The labels are located on right and left pivot brackets (Ref 20 and 32). The small boom assembly is the center boom. You can NOT order these boom assemblies as one unit. Please refer to parts drawing for individual parts.
2. Mount small boom assembly to rear upright support on sprayer using four boom brackets (Ref 10), four bolts,  $\frac{3}{8}$  - 16 x  $5\frac{1}{2}$  and four lock nuts,  $\frac{3}{8}$  - 16 (Ref 26). One boom bracket should go on boom assembly and one on upright support of sprayer. Do the same for right and left side. Place boom at desired level (approximately 20" (51 cm) nozzle height) and center. Tighten bolts.
3. The actuator brackets are incorporated into the boom holders (Ref 6 and 12) on the center mount (Ref 11) using  $\frac{3}{8}$  - 16 x  $1\frac{1}{4}$  bolts, washers and lock nuts, with washers over the slots. Snug up the bolts so that you can adjust the boom holders with the set screws (Ref 24) on the center mount after booms have been mounted.
4. Take right boom and slide pivot bracket (Ref 21) in center mount (Ref 11) and hold in place with  $\frac{1}{2}$  - 13 x  $5\frac{1}{2}$  bolt and  $\frac{1}{2}$  - 13 center lock nut (Ref 29). Do not over tighten, boom must be able to move up and down. Repeat for left boom.
5. Mount actuator (Ref 13) fixed end to actuator bracket and ram end to pivot bracket using  $\frac{1}{2}$  x  $2\frac{1}{4}$  clevis pins and  $\frac{1}{8}$  x 1 cotter pins (Ref 8). It may be necessary to lift boom slightly for proper fit. Repeat process for other boom.
6. Hook hoses to respective fittings using hose clamps (18-040). The hose coming from right side of sprayer goes to straight fitting on right boom. Center hose from sprayer goes to straight fitting on center boom. The left hose from sprayer goes to straight fitting on left boom. Be sure all clamps are tight.
7. Connect wire harness to actuator. Use two nylon ties (22-075) to hold wire to fixed end of actuators.
8. Use boom switches to completely extend actuator and lower booms.
9. Using set screws (Ref 24) adjust actuator brackets so nozzles of booms are at same height with nozzles of center section. Tighten bolts holding actuator brackets to center mount and locknuts on set screws.
10. Make certain set screws on the pivot brackets (Ref 21) on both sides are completely screwed in. Raise booms with boom switches all the way up, adjust set screws (Ref 24) so they contact the stop.



# NOZZLE ASSEMBLY DRAWING

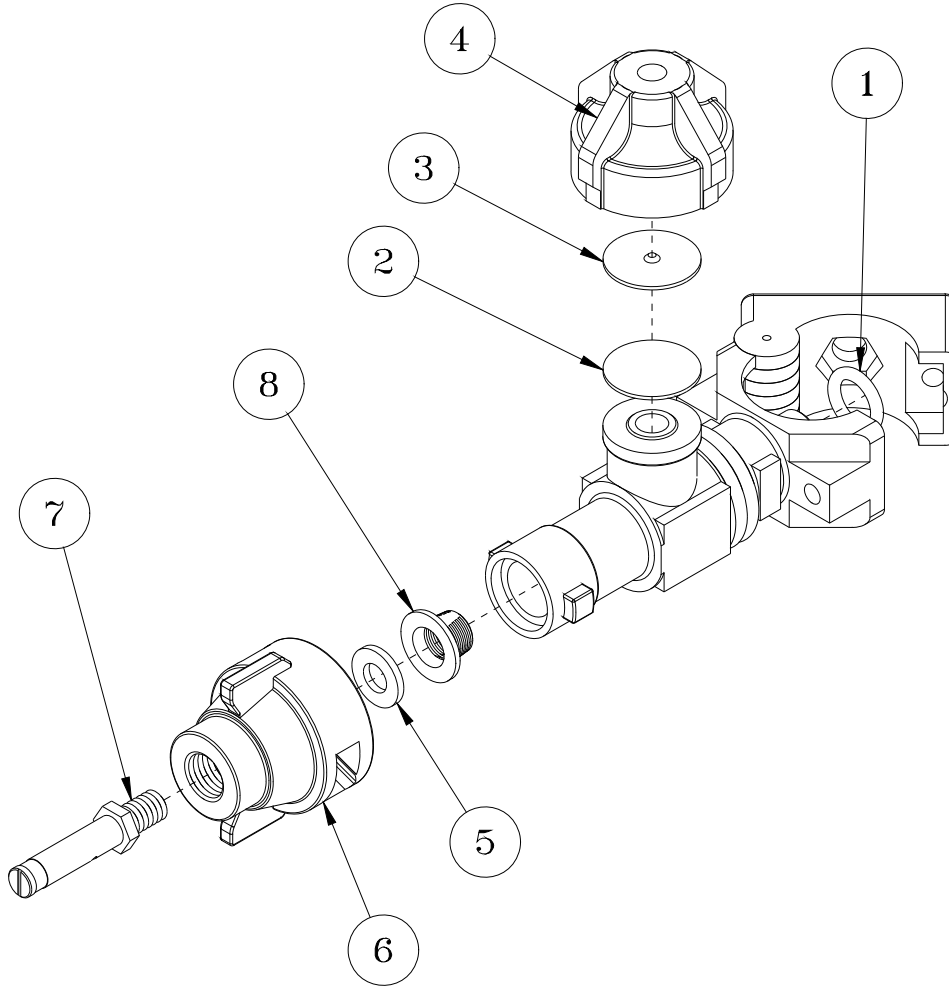

## NOZZLE ASSEMBLY PARTS LIST

REF#	PART#	DESCRIPTION	QUANTITY
1*	16-920-03	O-Ring	1
2*	16-920-05	Diaphragm Teflon (Optional)	1
3*	16-920-06	Diaphragm EPDM Rubber (Standard)	1
4*	16-798	Chemsaver End Cap	1
5	16-800	Gasket Viton	1
6	16-921	Cap	1
7	15-588	Turbo Turf Jet Tip #8	1
*	16-996	Body	1
Optional	33-550	10 Mesh Brass Strainer	
Optional	33-551	20 MESH Brass Strainer	

**NOTE:** When the 16-920-05 Teflon Diaphragm is used, it is placed in the assembly in front of the 16-920-06 EPDM Rubber Diaphragm. Nozzles are located 20" (51 cm) apart on the right, left, and center tubes. There are predrilled holes in all tubes. The Nozzle should be at a 45° angle to the ground for proper application.

## TURBO TURFJET TIPS

This is a wide-angle (110°), hollow-cone, drift-reduction nozzle. Replaces conventional flooding nozzles in broadcast applications.

### FEATURES:

- Color-coding makes it easy to match nozzle flow rates for easy identification.
- Color-coding is available in sizes 1/4 TTJ02-VS through 1/4 TTJ15-VS.
- Uniform spray distribution.
- A large orifice opening and passages minimize clogging.
- The Turbo TurfJet nozzle's patented design element, a secondary swirl chamber in the nozzle cap, alters the swirling action of the liquid so that the fewer driftable lines are discharged from the secondary orifice.
- Spraying Pressure 25-75 PSI (1.5-5 bar).

### NOZZLE TILT

Delavan's extensive research on spray patterns has proven that a tilt of about 45° for flood Nozzles or tips will significantly improve the spray pattern uniformity.

The nozzle tilt reduces the effect of boom height variation and allows the spray nozzle to maintain a more fully developed pattern even when the nozzle outlet is below the recommended height for the best spray pattern uniformity.

### RECOMMENDED OVERLAP AND NOZZLE HEIGHT

Adjust spray height in the field to overlap a minimum of 30% of each edge of pattern. Adjust nozzle height until this is achieved. If a decision to tilt the nozzle is made, do it before measuring the width of the spray on the ground and adjusting nozzle height. See example below.

### DRIFTABLE FINES PRODUCED

(0.5 gpm at 40 psi)

<b>Nozzle</b> (.5 gpm Output)	<b>Percent of Spray Volume</b> <b>less than 200 microns</b>
Turbo TurfJet	< 1%



This is an extended range flat spray tip. It is excellent for Contact Pesticides and Growth Regulators and good for Systemic Pesticides.

**Contact Pesticides and Growth Regulators** - At medium pressures (20-30 psi) provides medium size droplets for good surface coverage and less drift. At higher pressures (30-60 psi) produces smaller droplets for better coverage. Wide angle 110° tips produce slightly smaller droplets than 80° tips at equal pressures.

**Systemic Pesticides** - At lower pressures (15-20 psi) produces larger spray droplets and reduces drift while still providing uniform coverage along the boom.

#### FEATURES:

- Excellent spray distribution over a wide range of pressures (15-60 psi).
- Ideal for rigs equipped with sprayer controllers.
- Reduces drift at lower pressures, better coverage at higher pressures.
- Available in stainless steel and hardened stainless steel in 80° and 110° tip spray angles with VisiFlo color coding.

#### RECOMMENDED OVERLAP

Adjust nozzle spray height to overlap 30% of each edge of pattern.

#### NOZZLE HEIGHT

Suggested spray nozzle height with 20" spacing, tip spray angle of 80° should be 17-19", tip spray angle of 110° should be 12-14".



# 30-010 ELECTRIC HOSE REEL DRAWING

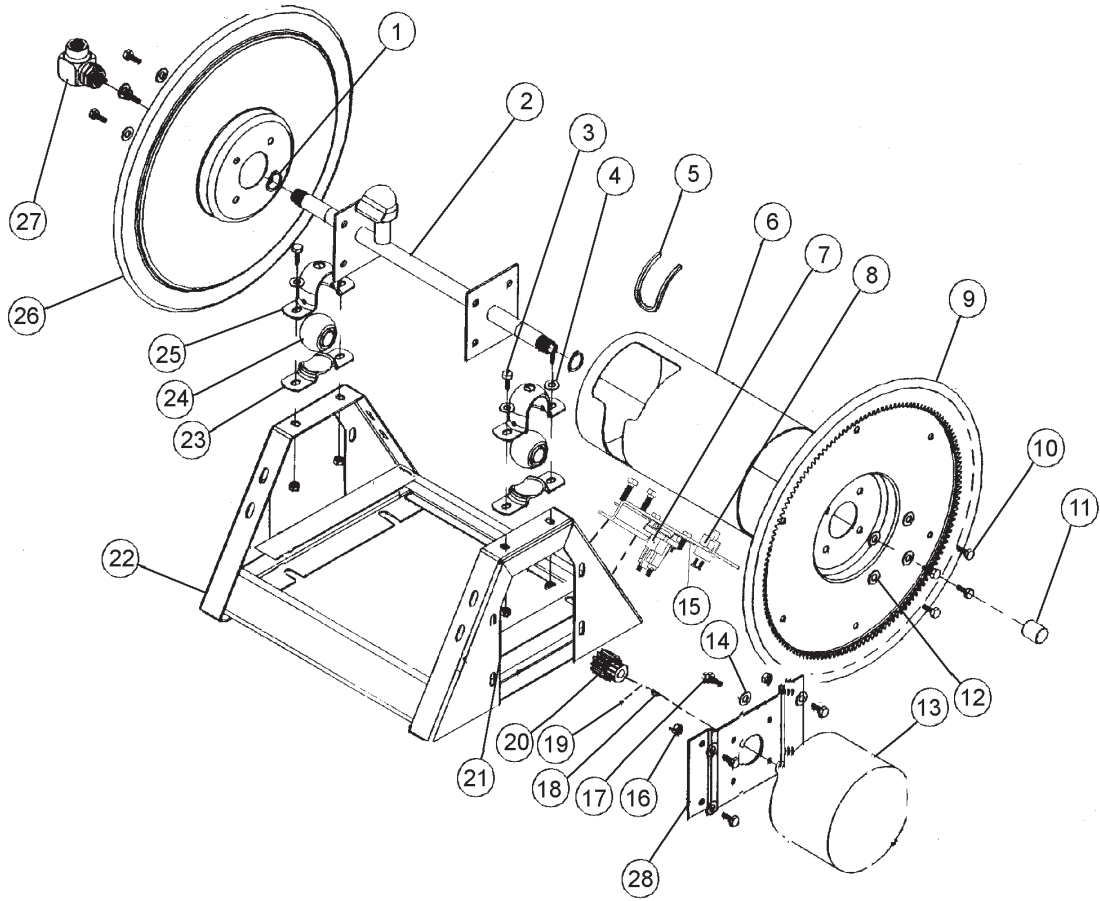

Accessories

## 30-010 ELECTRIC HOSE REEL PARTS LIST

REF#	PART#	DESCRIPTION	QUANTITY
1	16-906-25	Retaining Ring	2
2	16-906-22	Axle Assembly	1
3	HB-38-16-100	Bolt $\frac{3}{8}$ - 16 x 1	4
4	HW-38	Washer $\frac{3}{8}$	4
5	16-906-27	Trim, Drum Edge	1
6	16-906-21	Drum Center	1
7	13-750	Solenoid	1
	HB-14-20-075	Bolt $\frac{1}{4}$ - 20 x $\frac{3}{4}$	2
	HWL-14	Lockwasher $\frac{1}{4}$	2
	HN-14-20	Nut $\frac{1}{4}$ - 20	2
8	33-251	Switch	1
9	16-906-19	Disc and Gear Assembly	1
10	HB-516-18-075	Bolt $\frac{5}{16}$ - 18 x $\frac{3}{4}$	8
11	16-906-26	Pipe Cap $\frac{3}{4}$	1
12	HWL-516	Lockwasher $\frac{5}{16}$	8
13		Motor 12VDC	1
14	HW-516	Washer $\frac{5}{16}$	4
15	33-252	Switch and Solenoid Bracket	1
	HB-516-18-075	Bolt $\frac{5}{16}$ - 18 x $\frac{3}{4}$	2
	HW-516	Washer $\frac{5}{16}$	2
	HWL-516	Lockwasher $\frac{5}{16}$	2
	HN-516-18	Nut $\frac{5}{16}$ - 18	2
16	HNTL-516-18	Lock Nut $\frac{5}{16}$ - 18	4
17	HB-516-18-100	Bolt $\frac{5}{16}$ -18 x 1	4
18	16-906-17	Key	1
19		Set Screw	2
20	16-906-29	Pinion	1
21	HNTL-38-16	Lock Nut $\frac{3}{8}$ - 16	4
22	16-906-18	Frame Assembly	1
23	16-906-08	Mounting Pillow Block (Bottom)	2
24	16-906-24	Bearing	2
25	16-906-07	Mounting Pillow Block (Top)	2
26	16-906-20	Disc 17 $\frac{1}{2}$	1
27	16-906-23	Swivel Assembly $\frac{3}{4}$	1
	16-906-30	Seal Kit (For 16-906-23)	1
28	16-906-28	Bracket 12VDC	1
29	16-980	Mount Bracket	2
	HB-516-18-175	Bolt $\frac{5}{16}$ - 18 x 1 $\frac{3}{4}$	4
	HW-516	Washer $\frac{5}{16}$	4
	HNTL-516-18	Lock Nut $\frac{5}{16}$ - 18	4
	16-982	Electric Hose Reel (only)	1



# ELECTRIC HOSE REEL WIRING DIAGRAM

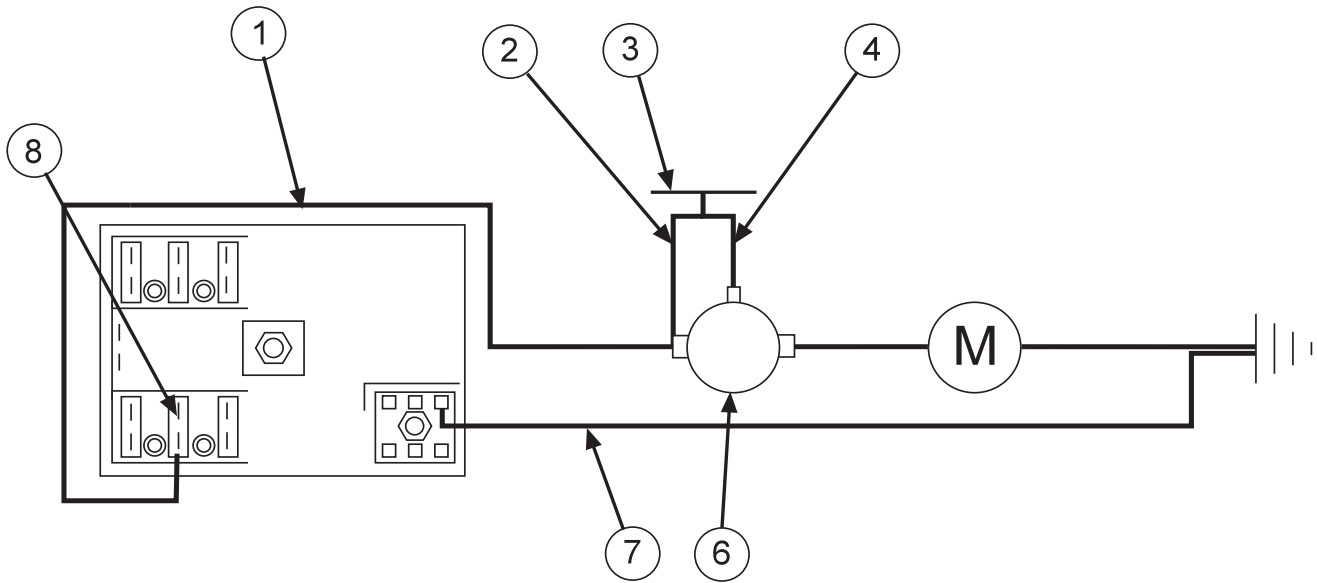

## ELECTRIC HOSE REEL WIRING PARTS LIST

REF#	PART#	DESCRIPTION	QUANTITY
	8843-132	Flexguard $\frac{3}{8}$ ID	1
1	8919-144	10GA Red Wire 144"	1
	8901	Slide-On Connector	1
2	16-979	Wire, Switch to Solenoid Hot Terminal	1
3	33-251	Push Button Switch	1
4	16-978	Wire, Switch to Solenoid Start Terminal	1
6	13-750	Solenoid	1
<b>SOLENOID TERMINALS</b>			
	HN -516-24	$\frac{5}{16}$ - 24 Hex Nut	2
	HN -10-32	10 - 32 Hex Nut	1
7	8931-144	10GA White Wire 144"	1
	8901	Slide-On Connector	1
8	33-273	Auto Blade Type Fuse 30Amp	1

### CONNECTION INSTRUCTIONS

Route wire harness along side of tank and over to fuse block taking care to stay clear of moving parts or hot engine components. Cut off excess wire and strip back  $\frac{3}{8}$ ". Place one 8963 heat shrink ( $\frac{1}{4} \times 1\frac{1}{4}$ ) on each wire before crimping 8901 slide on connectors to the red and white wires. Connect the two wires to the fuse block first the red to the (+) positive and the white to the (-) negative. Put the 33-273 auto blade type fuse (30 amp) into fuse block.



**Make certain you are connecting positive (+) to positive; negative (-) to negative while attaching power leads. If you do not observe polarity, damage will result to electrical components.**

*Use Dielectric Grease On All Electrical Connections*

# 30-009 MANUAL HOSE REEL DRAWING

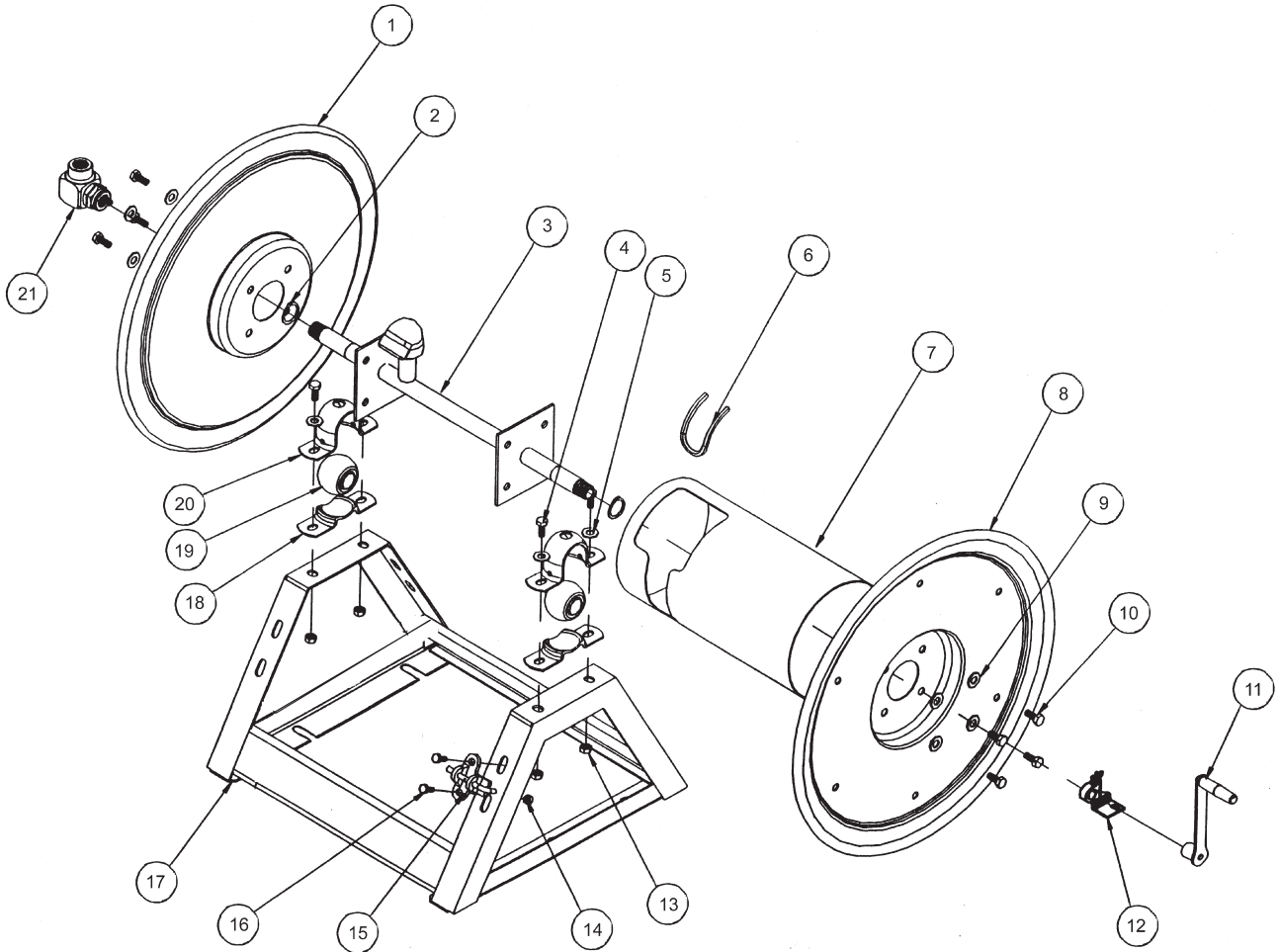

Accessories

## 30-009 MANUAL HOSE REEL PARTS LIST

REF#	PART#	DESCRIPTION	QUANTITY
1	16-129-11	Disc 17 <sup>1</sup> / <sub>2</sub>	1
2	16-906-25	Retaining Ring	2
3	16-906-22	Axle Assembly <sup>3</sup> / <sub>4</sub>	1
4	HB-38-16-100	Bolt <sup>3</sup> / <sub>8</sub> - 16 x 1	4
5	HW-38	Washer <sup>3</sup> / <sub>8</sub>	4
6	16-906-27	Trim, Drum Edge	1
7	16-906-21	Drum Center	1
8	16-906-20	Disc 17 <sup>1</sup> / <sub>2</sub> , Crank Side	1
9	HWL-516	Lockwasher <sup>5</sup> / <sub>16</sub>	8
10	HB-516-18-075	Bolt <sup>5</sup> / <sub>16</sub> - 18 x <sup>3</sup> / <sub>4</sub>	8
11	16-129-09	Crank Assembly <sup>3</sup> / <sub>4</sub>	1
12	16-129-10	Brake Assembly <sup>3</sup> / <sub>4</sub>	1
13	HNTL-38-16	Lock Nut <sup>3</sup> / <sub>8</sub> - 16	4
14	HNTL-516-18	Lock Nut <sup>5</sup> / <sub>16</sub> - 18	2
15	16-129-08	Lock Pin Assembly	1
16	HB-516-18-075	Bolt <sup>5</sup> / <sub>16</sub> - 18 x <sup>3</sup> / <sub>4</sub>	2
	HW-516	Washer <sup>5</sup> / <sub>16</sub>	2
17	16-129-07	Frame Assembly	1
18	16-906-08	Mounting Pillow Block (Bottom)	2
19	16-906-24	Bearing	2
20	16-906-07	Mounting Pillow Block (Top)	2
21	16-906-23	Swivel Assembly <sup>3</sup> / <sub>4</sub>	1
	16-906-30	Seal Kit ( For 16-906-23 )	1
22	16-980	Mount Bracket	2
	HB-516-18-175	Bolt <sup>5</sup> / <sub>16</sub> - 18 x 1 <sup>3</sup> / <sub>4</sub>	4
	HW-516	Washer <sup>5</sup> / <sub>16</sub>	4
	HNTL-516-18	Lock Nut <sup>5</sup> / <sub>16</sub> - 18	4



# HOSE REEL MOUNT DRAWING

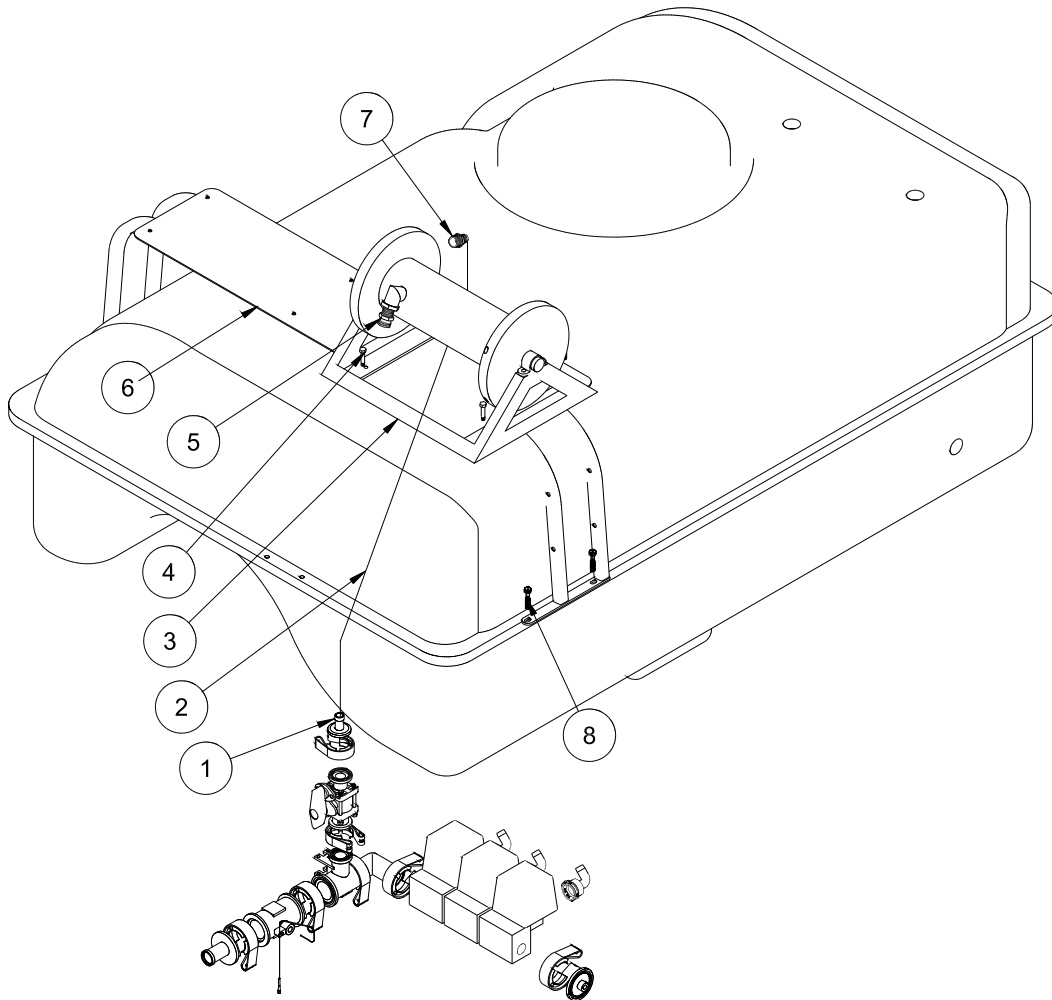



## HOSE REEL MOUNT PARTS LIST

REF#	PART#	DESCRIPTION	QUANTITY
1	15-749	Hose Barb $\frac{3}{4}$ "	1
2	8887-72	$\frac{3}{4}$ " Orange PVC Hose 72"	1
	18-040	Hose Clamp	2
3	16-129	Manual Rewind Hose Reel	1
4	HB-516-18-100	Bolt $\frac{5}{16}$ -18 x 1	4
	HWL-516	Lockwasher $\frac{5}{16}$	4
	HNFL-516-18	Flange Lock Nut $\frac{5}{16}$ - 18	4
5	16-295	Hose Fitting $\frac{3}{4}$ "	1
6	30-110	Hose Reel Mount bracket (part of 30-005-K)	1
7	18-249	Barb Fitting	1
8	HB-516-18-175	Bolt, $\frac{5}{16}$ -18 x $1\frac{3}{4}$ (part of 30-005-K)	4
	HNFL-516-18	Flange Lock Nut, $\frac{5}{16}$ - 18 (part of 30-005-K)	4

## INSTALLATION INSTRUCTIONS

1. Wear protective clothing when draining the tank and taking apart the lines.
2. Drain tank and spray system in a safe and approved method insuring that no chemical or water remain in tank as you will be taking apart lines.
3. Remove key from ignition, set park brake and block wheels.
4. Put hose reel on hose reel bracket with fitting to the rear of machine. Use four bolts  $\frac{5}{16}$  - 18 x 1 and four  $\frac{5}{16}$  - 18 lock nuts to hold in place. Tighten bolts.
5. Put 18-249 barb fitting into hose reel side.
6. Place the 16-295 Hose Fitting into the Hose reel center.
7. Remove the blank cover from the ball valve by the manifold valve and place the 15-749 Hose Barb. Tighten clamp.
8. Route hose from the hose barb on the ball valve to the barb fitting on the side of the hose reel. Hold in place with the two 18-040 clamps.
9. Be sure all clamps and hardware are tight before using.

## HOSE REEL ADJUSTMENTS

### OPERATIONAL CHECK:

1. Pull hose off drum at least one full revolution. A clicking noise should be heard from locking mechanism.
2. Let the hose retract.
3. Pull the hose off until the first click is heard. Drum should lock when the hose tension is removed.
4. Continue pulling the hose, no more than one revolution, until no clicking is heard. Hose should rewind when tension is removed.

### HOSE REPLACEMENT PROCEDURE:

1. Facing swivel, turn the hose drum clockwise until all of the hose is removed from the drum and the drum is held by locking mechanism. Make sure spring is locked.
2. Remove hose clamps and disconnect hose from swivel. Remove old hose.
3. Insert new hose through roller guide, connect to swivel and reinstall hose clamps. Use spring guard over hose to protect the hose from being cut by the drum.
4. Remove check ball from old hose and install on replacement hose.
5. Carefully, keeping the tension on the hose, pull the hose to release the locking mechanism. Let the hose wind on the drum.



# 30-004 FOAM MARKER DRAWING

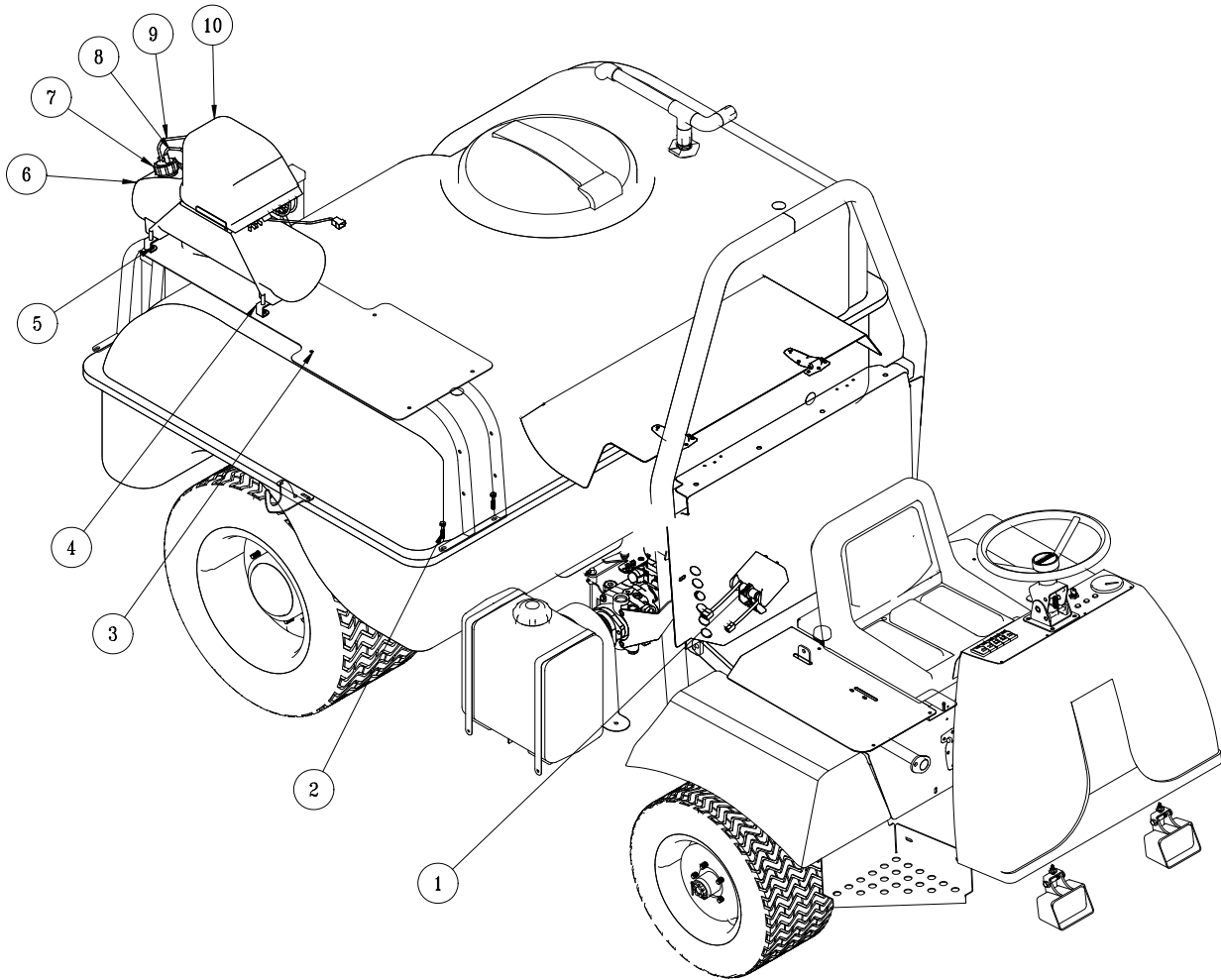

# WIRING DRAWING

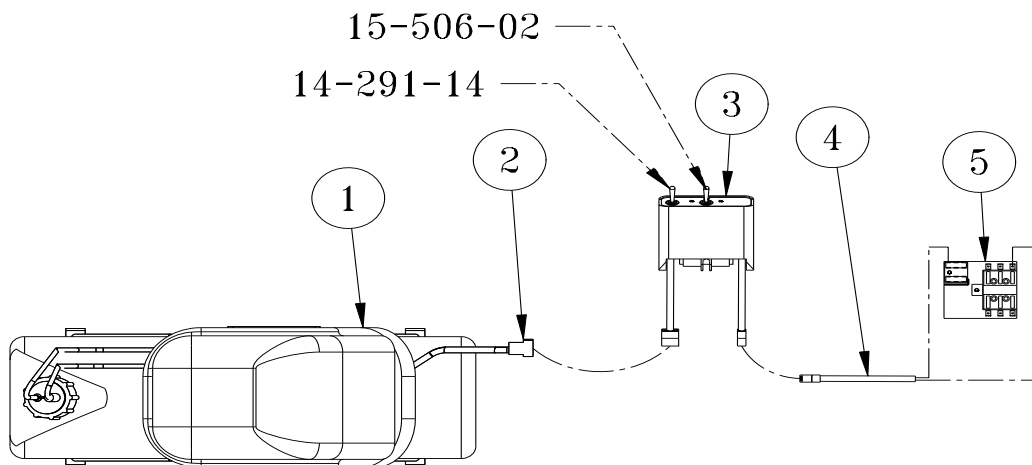

Accessories

## 30-004 FOAM MARKER PARTS LIST

REF#	PART#	DESCRIPTION	QUANTITY
1*	14-291-05	Double Switch Box	1
	15-506-01	Fuse (F10A 250)	1
	15-506-02	Switch	1
2	HB-516-18-175	Bolt, $\frac{5}{16}$ -18 x $1\frac{3}{4}$ (part of machine)	4
	HNFL-516-18	Flange Lock Nut, $\frac{5}{16}$ - 18(part of machine)	4
3	30-110	Mount Bracket (part of machine)	1
4*	14-291-04	Tank Bracket	2
5	HN-14-20-075	Hex Bolt, $\frac{1}{4}$ -20 x $\frac{3}{4}$	2
	HBFL-14-20	Flange Lock Nut, $\frac{1}{4}$ -20	2
6*	14-291-02	Foamer Tank	1
7*	14-284-02	Cap Assembly	1
8*		Blue Tube	1
9*		Clear Tube	1
10*	14-291-03	Compressor Only	1
	14-291-01	Black Cover	1
*	14-291	Foamer (includes * parts)	1

## WIRING PARTS LIST

REF#	PART#	DESCRIPTION	QUANTITY
1	14-291-03	Compressor	1
2	15-504-04	Wiring Harness	1
3	14-291-05	Switch Box	1
	15-506-01	Fuse (F10A 250V)	1
	15-506-02	Switch	1
4	15-509	Power Cable	1
5	33-271	Fuse Block (part of machine)	1
	33-293	Auto Blade Type Fuse 30 amp	1



# 30-004 FOAM MARKER DRAWING

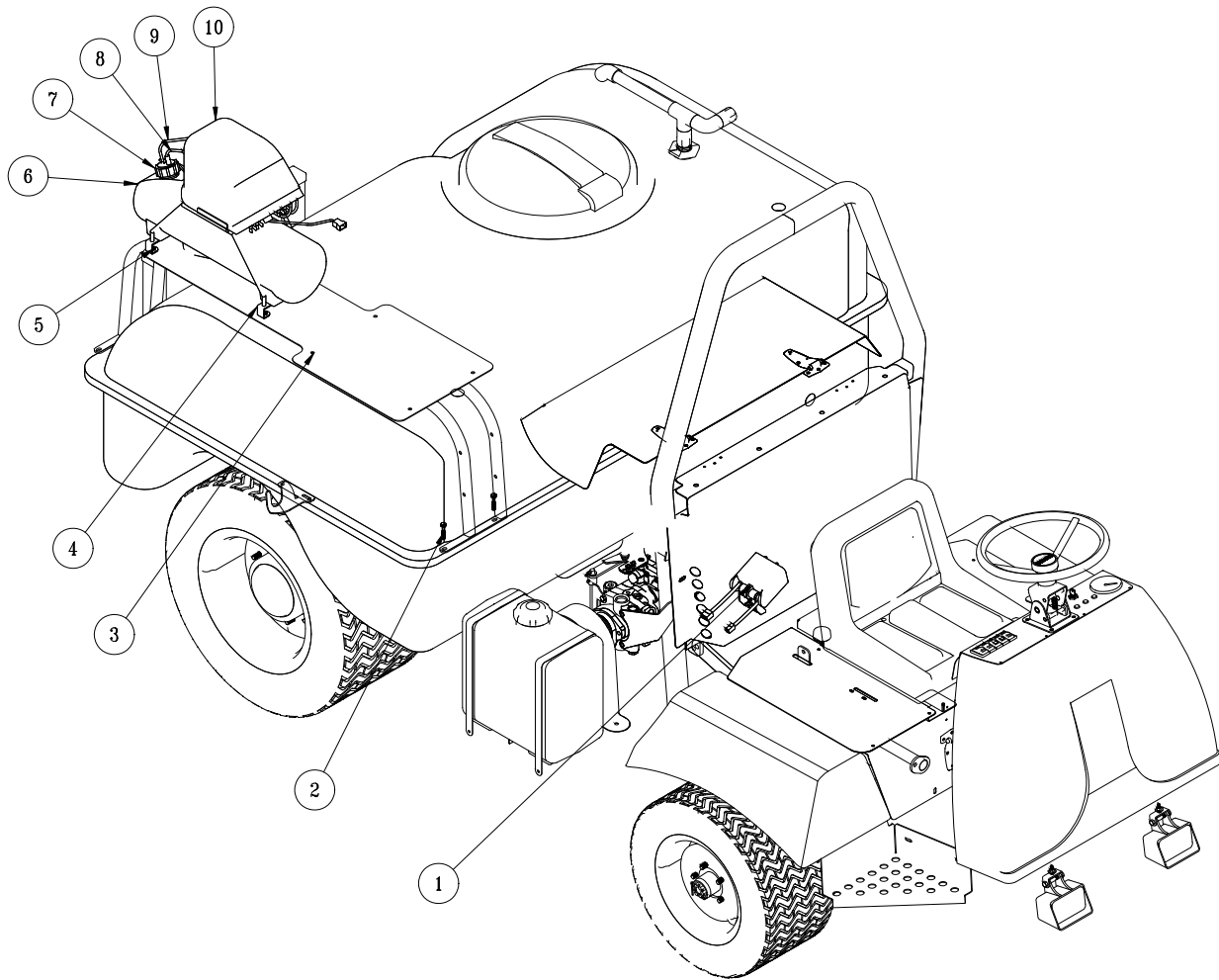

Accessories

**Safety: Before working on machine stop engine, set park brake, remove key from ignition and block wheels. Disconnect negative (-) battery terminal.**

### SWITCH BOX

Mount the switch box to the panel to the right of the operator's seat. Remove the drill screw on the right hand rear side and mount the Switch Box using this screw. The switch box must be mounted facing towards the operator's seat.

### WIRING

Use dielectric grease on all electrical connections. Connect power cable (15-509) to the switch box. Turn the switch off. Route the power wire to the fuse block (on the inside of the engine cover) out of the way of any heat or moving parts. Use nylon ties as needed. Cut the power wire with enough length to connect the fuse block. Put the slide on terminal with heat shrink onto the wire ends and connect to fuse block. Red to positive(+), black to negative(-). Insert 10 amp fuse into slot which has red wire attached to it.

### CONNECTING THE CAP ASSEMBLY

Connect the blue tube to the tank cap connector which is also connected to the large blue tube which hangs below the cap. This is the soap outlet tube. Connect the clear tube to the other connector on the tank cap. This is the air input tube. Tighten connectors hand tight, assembly tank cap onto tank.

### HOSES

Being careful not to cut the tubing, cut the oversleeve back approximately 2" (5 cm) to expose blue and clear tubing. Remove blue wing nut from top connector of foam nozzle and slide it on the blue tube with the threads facing toward end of tube. Slide blue tube all the way over the top of the small tube on foam nozzle. Slide wing nut back to the threads and hand tighten. Follow the same steps for the clear tube and tube nut.

Route the tubing along underside of main frame using tie downs as necessary.

Install opposite ends of air-liquid tubes to compressor, again cutting back the oversleeve approximately 2" (5 cm) and inserting blue and clear tubes for the left boom section into the tubing connectors on the right side of compressor as far as possible. Follow the same steps for the right boom tubing. Notice the right boom is inserted into left side of compressor. To release tubing from compressor, hold black ring around tubing, and pull tube out.

# FOAMER NOZZLE MOUNT & HOSE GUARD MOUNT DRAWING

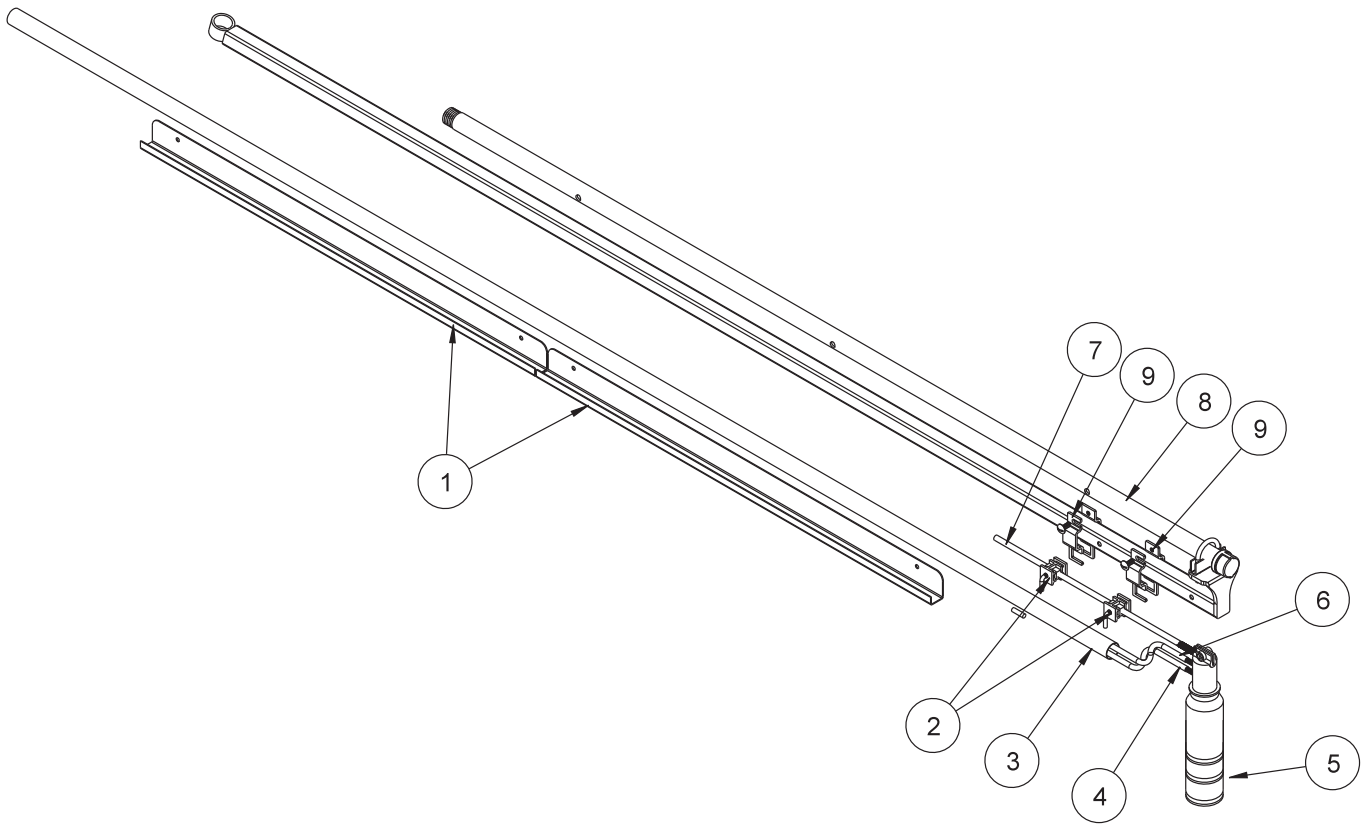

Accessories

## 30-004 FOAM MARKER PARTS LIST

REF#	PART#	DESCRIPTION	QUANTITY
1	15-537	Foamer Hose Guard 31"	4
	HSDPS-14-075	Stainless Steel Pan Head Drill Screw $\frac{1}{4} \times \frac{3}{4}$	8
2	16-987	Foam Nozzle Mounting Kit	1 per boom
3	15-507	Foamer Tubing	2
4		Clear Tubing	
5	15-511	Foam Nozzle	2
6		Blue Tubing	
7	15-510-01	Nozzle Mounting Rod	2
8		Boom	
9	16-795	Square Clamp	4

## INSTALLATION INSTRUCTIONS

1. Slide hose clamp onto drop tube of foam nozzle and attach restrictor bell.
2. Place splined end of Nozzle mounting rod (Ref 7) into top of foam nozzle (Ref 5). Tighten screw.
3. Slide two foam nozzle mounts (Ref 2) onto the rod. Place square clamps (Ref 9) on foam nozzle mounts and mount the square clamps to the boom (Ref 8). Adjust foam nozzle mounts and clamps so nozzle assembly will clear end of boom. Tighten foam nozzle mounts and square clamps to prevent side to side movement. Do the same to the other side.
4. Being careful not to cut the tubing (Ref 3), cut the oversleeve back approximately 2" (5 cm) to expose blue (Ref 6) and clear tubing (Ref 4).
5. Remove blue wing nut from top connector of foam nozzle and slide it on the blue tube with the threads facing toward end of tube. Slide blue tube all the way over the top of the small tube on foam nozzle. Slide wing nut back to the threads and hand tighten. Follow the same steps for the clear tube and tube nut.
6. Route the tubing along underside of main frame using tie downs as necessary.
7. Install opposite ends of air-liquid tubes to compressor, again cutting back the oversleeve approximately 2" (5 cm) and inserting blue and clear tubes for the left boom section into the tubing connectors (Ref A) on the right side of compressor as far as possible.
8. Follow the same steps for the right boom tubing. Notice the right boom is inserted into left side of compressor. To release tubing from compressor, hold black ring around tubing, and pull tube out.
9. Hose's must be routed on bottom of the boom square tubing.
10. Mark 6 inches in from inside edge of foamer nozzle mounting bracket on square boom tubing.
11. Place hose guard (Ref 1) flush with top of square tubing with edge on previous mark. The channel covers hoses on the bottom of the square tubing.
12. Install hose guard using 2 drill screws (you may want to drill a  $\frac{3}{16}$  pilot hole first).
13. Place another hose guard against first and install in same manner.
14. Repeat process for other boom side.
15. Connect small plastic electrical plug under compressor to electrical extension cable.
16. For *Spray Star 1600* route extension cable under engine along the mainframe cross bar, using tie downs as necessary.
17. Cut cable and strip casing, allowing enough length to connect to fuse block.
18. Strip and connect slide on connectors to each wire and use the heat shrink.
19. Connect black negative (-) wire to the ground and connect red wire to the positive (+).
20. Insert 10 amp fuse into slot which red wire was attached to.

# FOAM MARKER DRAWING



Accessories



## FOAM MARKER PARTS LIST

REF#	PART#	DESCRIPTION	QUANTITY
1	15-507	Foamer Tubing	2
2	14-291-02	Tank	1
3	14-291-01	Black Cover	1
	14-291-03	Compressor	1
4	14-284-02	Cap Assembly	1
5	14-291-04	Tank Bracket	1
6	14-291-05	Double Switch Box	1
7	15-511	Foam Nozzle	1
8	15-510-01	Nozzle Mounting Rod	1
9	16-987	Foam Nozzle Mounting Kit	1

# 15-505 MOTOR SUB ASSEMBLY DRAWING

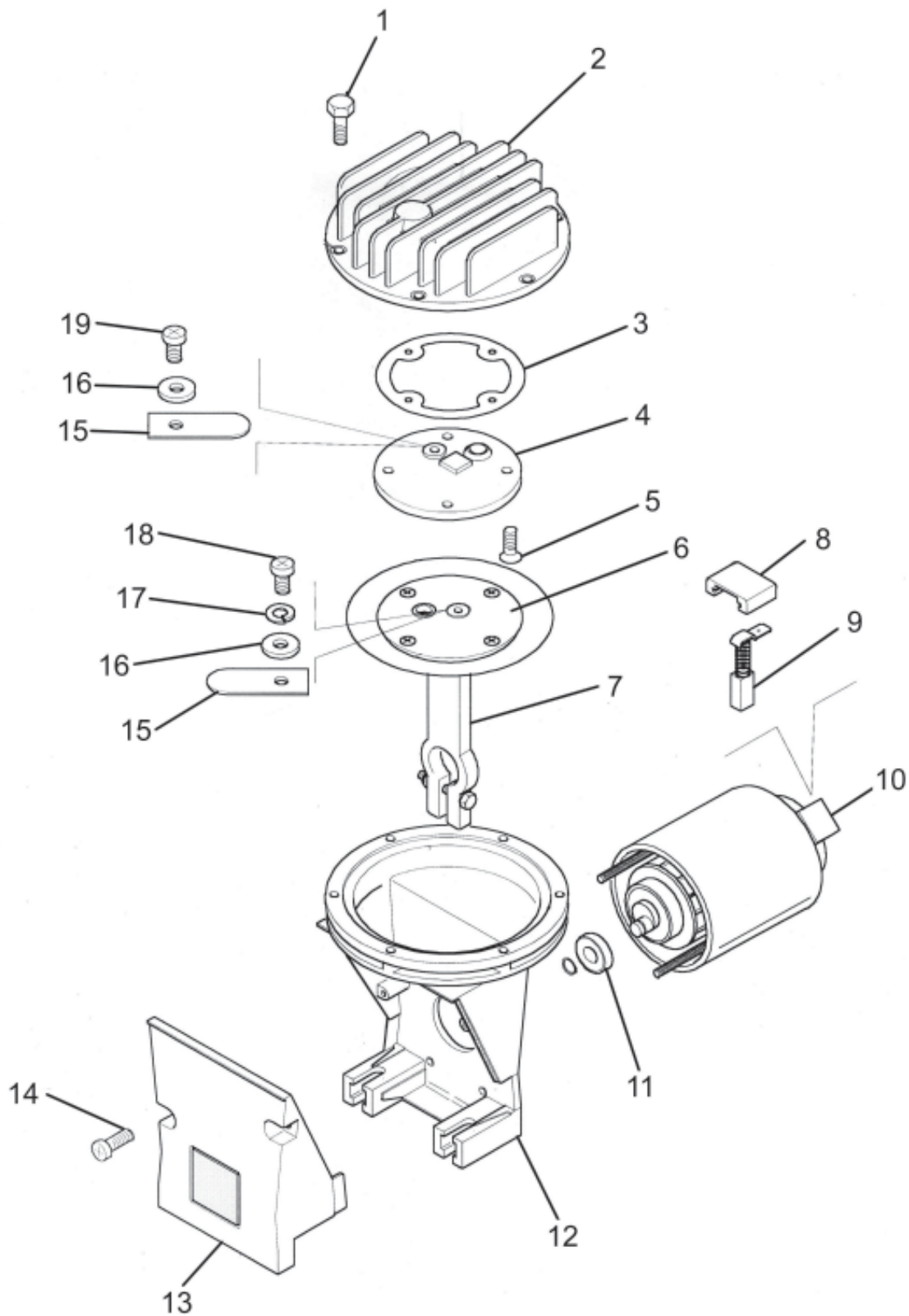

Accessories

## 15-505 MOTOR SUB ASSEMBLY PARTS LIST

REF#	PART#	DESCRIPTION	QUANTITY
1†		Bolt	6
2		Head	1
3	15-505-01	Exhaust Manifold Gasket	1
4		Exhaust Manifold	1
5†		Manifold Screw	8
6†	15-505-03	Diaphragm	1
7†		Piston	1
8		Brush Retainer	2
9	15-505-06	Brush	2
10	15-505-07	12 Volt Electric Motor	1
11	15-505-05	Stainless Steel Bearing	1
12		Block	1
13		Cover	1
14		Cover Screw	2
15*		Exhaust Reed Valve	1
16*†		Washer	2
17*†		Split Lockwasher	1
18*†		Intake Valve Screw	1
19*		Exhaust Valve Screw	1
*	15-505-02	Intake Exhaust Valve Sub Assembly	
†	15-505-04	Intake Piston Sub Assembly	



15-511 FOAM NOZZLE SUB ASSEMBLY DRAWING

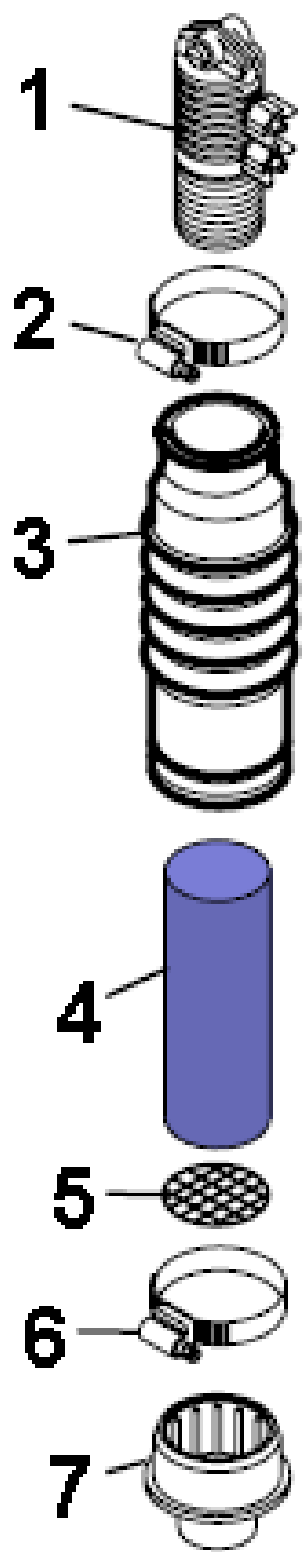

Accessories

## 15-511 FOAM NOZZLE SUB ASSEMBLY PARTS LIST

REF#	PART#	DESCRIPTION	QUANTITY
1*	15-511-01	Foam Nozzle Inlet Body	1
	15-510-01	Nozzle Mounting Rods	2
2*		Hose Clamp	1
3*		Drop Tube	1
4	15-511-08	Foam Sponge	1
5	15-511-09	Stainless Steel Screen	1
6		Hose Clamp	1
7	14-284-09	Foam Nozzle Reducer	1
*	15-511-07	Foam Nozzle Sub Assembly	

# 30-006 FRESH WATER TANK DRAWING

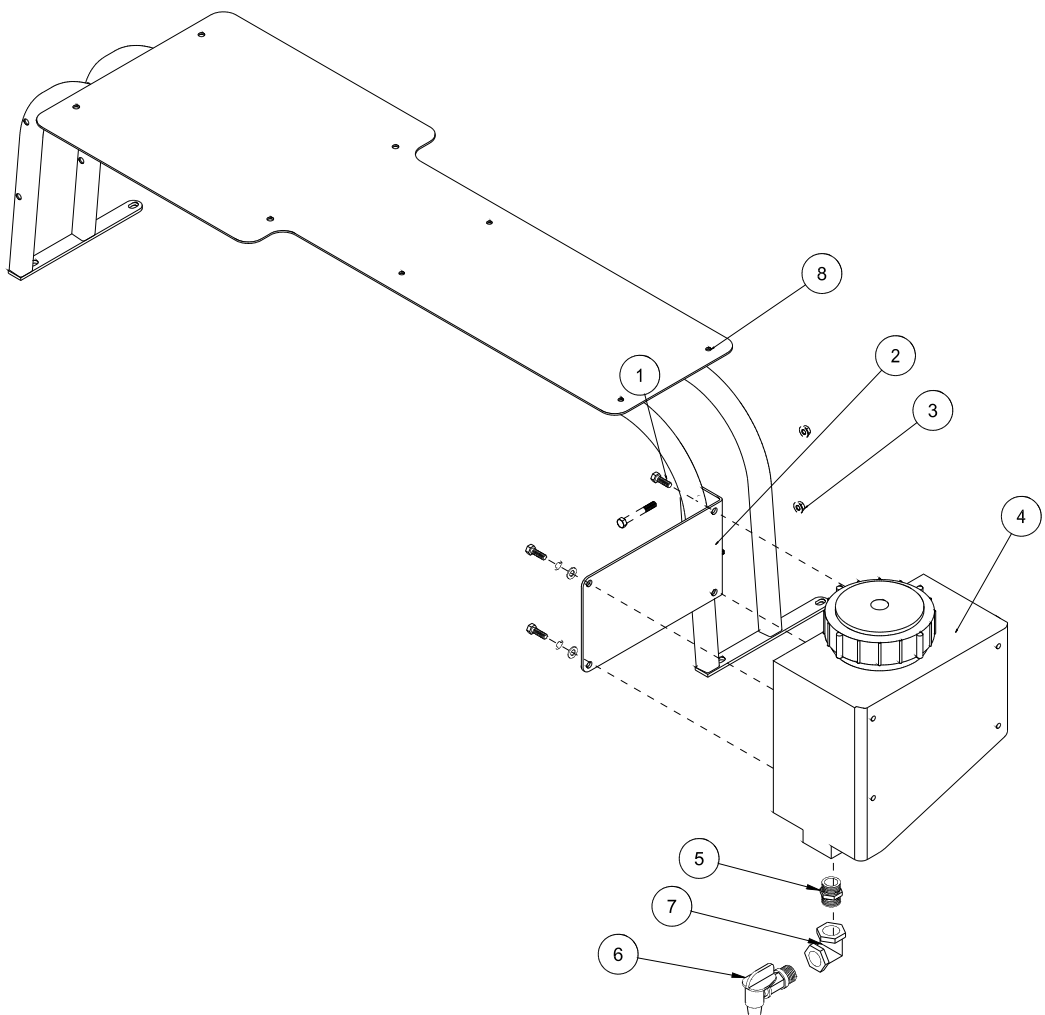

Accessories



## 30-006 FRESH WATER TANK PARTS LIST

REF#	PART#	DESCRIPTION	QUANTITY
1	HB-516-18-075	Bolt $\frac{5}{16}$ - 18 x $\frac{3}{4}$	4
	HW-516	Washer $\frac{5}{16}$	4
	HWL-516	Lock Washer $\frac{5}{16}$	4
2	30-111	Tank Mount Bracket	1
3	HB-516-18-150	Bolt $\frac{5}{16}$ - 18 x $1\frac{1}{2}$	2
	HNFL-516-18	Flange Lock Nut $\frac{5}{16}$ - 18	2
4	10-234	3 Gallon Rectangular Tank	1
5	16-158	Close Nipple $\frac{3}{4}$ x $\frac{3}{4}$	1
6	16-960	Spigot $\frac{3}{4}$ NPT	1
7	16-151	Elbow FPT $\frac{3}{4}$ x $\frac{3}{4}$	1
8	30-110	Mount Bracket (part of machine)	1

## INSTALLATION INSTRUCTIONS

1. Fresh Water Wash Tank mounts on the rear of the machine.
2. Clamp the mount bracket to the Mount Bracket and mark the holes onto the tube with a center punch. Drill the two holes using a  $\frac{3}{8}$  drill bit.
3. Secure the bracket to the post with two  $\frac{5}{16}$  x  $1\frac{1}{2}$  bolts and flange lock nuts. Then tighten.
4. Install the nipple (Ref 5), elbow (Ref 7) and spigot (Ref 6) into the bottom of wash tank (Ref 4). Use thread tape on all threads.
5. Mount the tank onto the mount bracket (Ref 2) using four  $\frac{5}{16}$  x  $\frac{3}{4}$  bolts, washers and lockwashers. Tighten.
6. Rinse tank with clear water and check for leaks around fittings.



This tank is for fresh clear water ONLY. Do not put chemicals in this tank.

14-515 WATER METER KIT (GALLONS)

15-618 WATER METER KIT (LITERS)

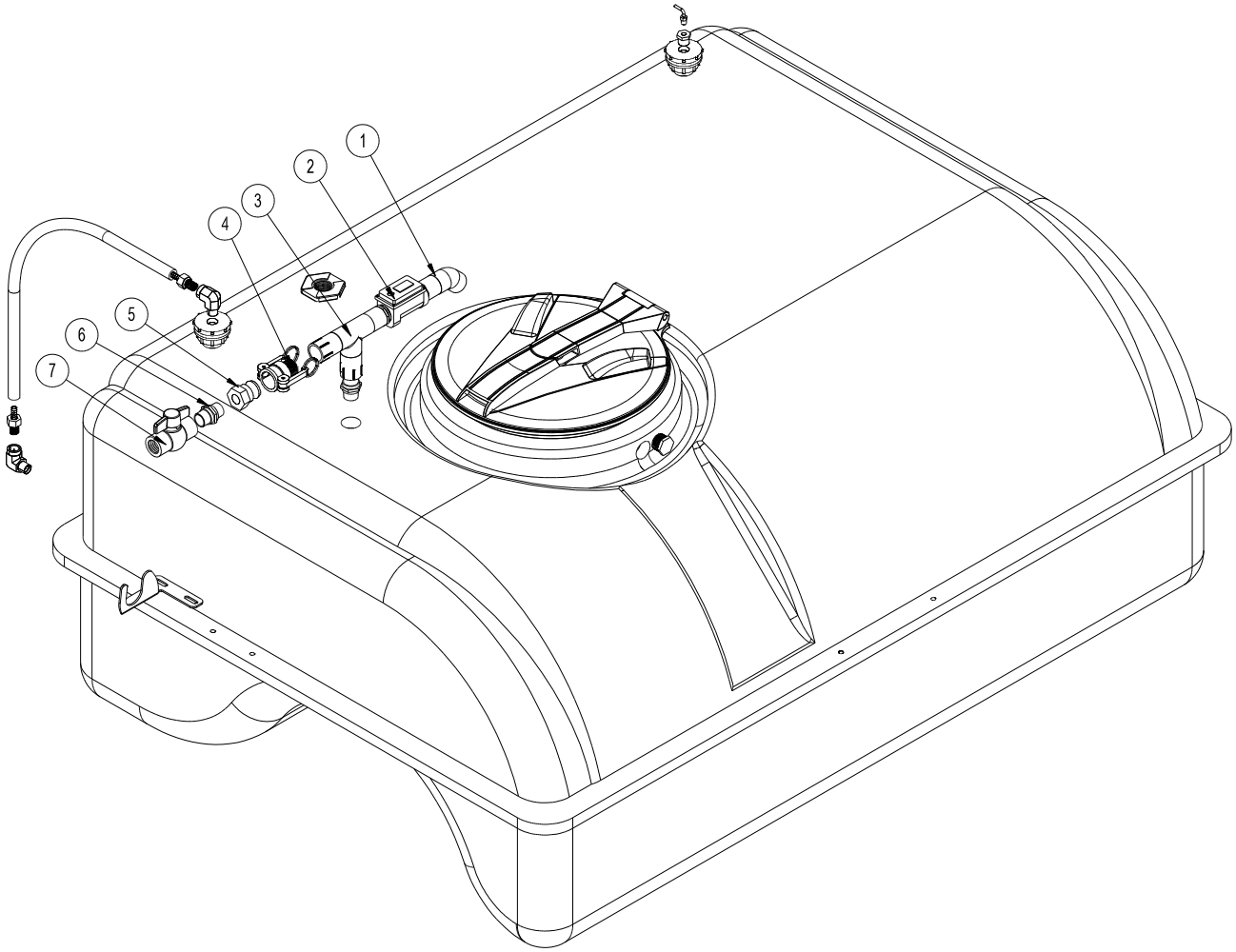

Accessories



## WATER KIT PARTS LIST

REF #	PART #	DESCRIPTION	QUANTITY
1	14-524	Filler Outlet	1
2	14-514	Water Meter (Gallons)	1
	14-527	Water Meter (Liters)	1
3	14-525	Filler Inlet	1
4	16-962	1" Quick Coupler (already on machine)	1
5	16-961	1" Adapter Quick Coupler (already on machine)	1

## WATER METER KIT INSTRUCTIONS

1. Thoroughly flush the service line upstream of the meter to remove dirt and debris.
2. The DLJ Meter is for use **only** with **COLD WATER** up to 122°F (50°C)
3. Slowly open any upstream valves to prevent damage to the meter.

### **Gallons to Cubic feet Conversion :**

Multiply gallons reading by 0.1337 to get cubic feet.

There are 7.48052 gallon per cubic foot.

# 30-007 CHEMICAL CLEANLOAD DRAWING

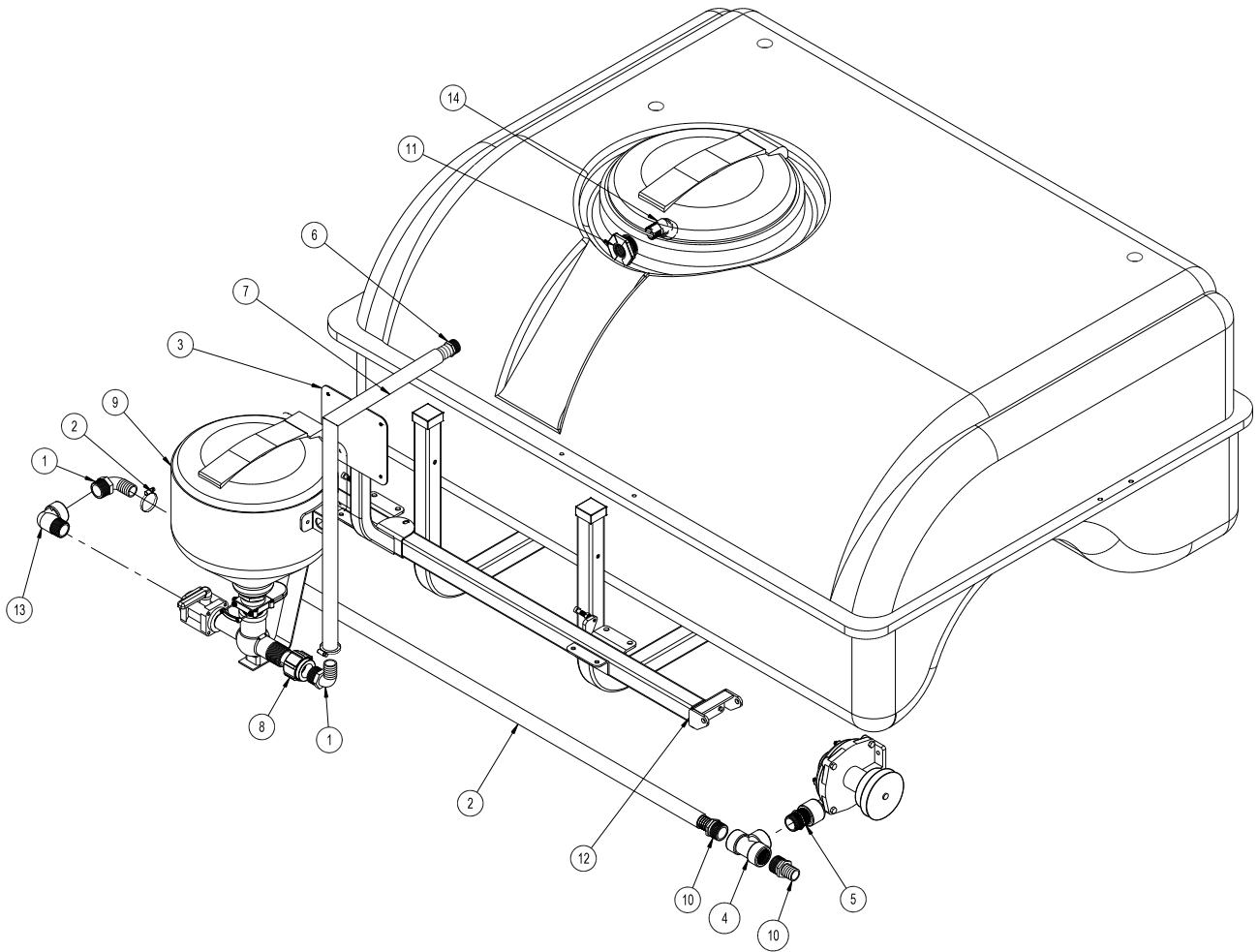

Accessories

## 30-007 CHEMICAL CLEANLOAD PARTS LIST

REF#	PART #	DESCRIPTION	QUANTITY
1	16-156	Elbow	2
2	8897-90	1 1/4" Discharge Hose 90"	1
	18-116	Hose Clamp	2
3	15-816	Cleanload Mount	1
	HBFL-516-18-075	Flange Bolt	4
	HNFL-516-18	Flange Lock Nut	4
4	18-390	Pipe Tee	1
5	16-880	Close Nipple	1
6	16-159	Fitting	1
7	8897-38	1 1/4" Discharge Hose 38"	1
	18-116	Hose Clamp	2
8	18-390	Coupling	1
9	15-620	Cleanload Assembly	1
10	16-161	Fitting	1
11	16-945	Fitting (part of tank)	1
12		Center Boom	1
13	16-972	90° Elbow	1

## INSTALLATION INSTRUCTIONS

1. Make sure sprayer tank is empty and flush all chemical residue from sprayer. Always wear protective clothing, goggles and gloves.
2. Disconnect outlet hose from the spray pump then the 90° fitting from the pump.
3. Install the close nipple, tee, straight fitting and the 90° elbow that was removed from the pump. Always use thread sealant on all fittings. Tighten all Fittings. One of the 90° fittings should point towards the right side of the machine and the other one needs to point to the back of the machine.
4. Reinstall the outlet hose onto the spray pump and tighten hose clamp.
5. Install 90" of 1 1/4" discharge hose onto the elbow on the pump that points back and tighten hose clamp.
6. Route the 90" hose to the back of the sprayer so it connects over the top of the left boom support tube.
7. Install the right and left mount bracket (Ref 3) onto the left boom support and secure with 3/8 x 2 3/4 bolts and top lock nuts, Tighten.
8. Mount Cleanload Assembly onto mount brackets using 5/16 x 3/4 flange bolts and flange nuts. Tighten.
9. Install 18-391 reducer coupling (Ref 8) onto outlet side. Then a 16-156 90° elbow (Ref 1) into the coupling pointing up and one into valve with yellow handle. Tighten fittings so that the elbow in the valve is pointing up and forward. The outlet fitting should be pointing up.
10. Remove the plug from the top back of the spray tank and install 16-159 hose barb (Ref 6) and tighten. Now the 38" hose can be installed from the tank to the outlet fitting and tighten with clamps.
11. The hose from the spray pump can be connected to the inlet fitting and tightened with clamps.
12. Make sure all hardware, fittings and clamps are tight. Add about 25 gallons of water to the spray tank. Start sprayer and circulate water through system to check for leaks.
13. Be sure to read start up, loading and shutdown instructions for Cleanload Assembly before using with chemicals. When working with chemicals **Always** wear protective clothing, goggles and gloves.



# OPERATING INSTRUCTION

## STARTUP

1. All Cleanload valves must be closed prior to starting: inlet ball valve, knife valve and hopper rinse ball valve.
2. Open lid to check for foreign objects which may hinder performance or contaminate the system.
3. Close and lock lid by turning cover clockwise.
4. Divert pump flow to Cleanload inlet line. A pressure of 30 PSI minimum and 150 PSI maximum must be used. Highest pressures increase eduction rate and available wand suction.
5. Turn inlet ball valve on (yellow handle).
6. Open knife valve, located on the bottom of hopper, by pushing handle in (red handle).
7. Unlock and open lid slowly by turning cover counterclockwise.

## LOADING LIQUID OR POWDERED CHEMICAL INTO HOPPER

8. Pour required amount of chemical into hopper. Avoid splashing liquids or powdered chemicals outside of hopper.
9. Rinse empty chemical containers if applicable. Place container opening over container rinse valve and press down. This will activate the rinse valve and rinse container.
10. Rinse Cleanload hopper. Close and lock lid by turning cover clockwise. Release the safety locking band on the hopper rinse ball valve and turn on for 20 seconds. Close ball valve and return locking band to locked position.
11. Open lid and inspect for chemical residue. Repeat step 10 as necessary.
12. Close knife valve by pulling red handle out towards you. Turn inlet (yellow handle) off.

## LOADING LIQUID AND/OR POWDERED CHEMICAL WITH SUCTION LANCE

**Note: Lance suction is dependent upon eductor pressure and flow. For best results, use highest pressure available up to 150 PSI maximum.**

8. Insert lance body with o-ring into eductor until the o-ring is sealed.
9. Use the free end of the lance to pierce bag or container to vacuum powdered or liquid chemical.
10. Rinse lance. Place lance end into a clean container of water to rinse lance assembly.
11. Remove lance body from eductor and drain any remaining fluid into hopper.
12. Close knife valve (red handle). Turn inlet valve (yellow handle) off.

## SHUTDOWN

1. Ensure that:
  - All valves are closed. Be sure to close knife valve first. (Close by pulling red handle out towards you.)
  - Chemical residue has been cleaned.
  - Hopper lid is closed and locked by turning cover clockwise.
2. Divert pump flow back to normal operation.

Symptom	Corrective Action
Low education rate	Check pump pressure and flow. Cleanload Eductor performance is based on flow and pressure to the system. Note requirements for high education rates.
	Increase outlet hose size back to tank.
Plugged or clogged bottle rinse nozzle	Disassemble rotary portion of nozzle from lower valve assembly and back flush until nozzle ports are clear of debris.
Plugged or clogged tank rinse nozzle	Disassemble rotary portion of nozzle from NPT hose barb and back flush until nozzle ports are clear of debris. Remove screen and flush with water to clear away foreign material.
Fitting leaks	Check for cracks in fitting. Replace fitting if necessary. Disassemble and add more joint seal in compound if leak occurs on threads.



This is a list of decals located on the Spray Star 3180. Part number, description and location will help in reordering decals.

15-463	Decal, Spray Pump	Right Side Panel
16-228	Decal, Over the Road towing	Front Seat Panel
25-277	Decal, Battery Warning	Battery
25-279	Decal, Safety Warning	Belt Guard
25-286	Decal, Pinch Point	Both Sides of Seat Panel
25-298	Decal, Warning Hot	Cooler Guard, Above Muffel on Tank Side, Panel Behind Seat
25-321	Decal, Refuel w/ Diesel	Front Right Tank
25-356	Decal, Tire Pressure 20psi	Front Tires
25-371	Decal, Diesel	Sides of Engine Cover
25-372	Decal, 4" Star	Rear Tank, Computer Cover
25-376	Decal, 98 dBA	Panel Behind Seat
25-380	Decal, Tire Pressure 30psi	Rear Tires
27-077	Decal Smithco	Steering Wheel
27-093	Decal, Hydraulic Oil Level	Oil Tank
30-016	Decal, Spray Star 3180	Tank Sides
30-017	Decal, Dashboard	Dashboard
30-019	Decal, Site Gauge	Tank Fill Hose
30-097	Decal, Control Panel	Right Side Panel
30-112	Decal, Speed Control	Left Side Panel
30-117	decals, Ultra Fuel	Fuel Tank
34-147	Decal, Smithco Logo	Nose Cone

## QUICK REFERENCE REPLACEMENT PARTS

### REPLACEMENT FILTERS

60-215	Hydraulic Oil Filter Assembly
60-334	Oil Filter
30-042-05	Air Cleaner Cartridge
13-488	Key Switch
30-042-08	Fuel Filter Element
30-042-09	Engine Oil Filter

### REPLACEMENT BELTS

30-023	Spray Pump Belt
--------	-----------------

### SEAL KITS

15-301	Power Steering Orbital Motor
15-301-01	Seal Kit
30-101	Wheel Motors
30-101-11	Seal Kit
30-102	Hydrostatic Pump
33-058-01	Seal Kit
30-098	Gear Pump
30-098-01	Seal Kit

### FLUIDS

Engine Oil	SAE 10W-40 API Service SJ or higher Motor Oil
Hydraulic Fluid	SAE 10W-40 API Service SJ or higher Motor Oil

### OTHER PARTS

16-953	Hinged Cover On Tank with Gasket
16-953-01	Gasket For Cover



# The Smithco Commercial Products Two-Year Limited Warranty

Smithco, Inc. (Smithco) warrants your 2007 or newer Smithco Commercial Product ("Product") purchased after January 1, 2007, to be free from defects in materials or workmanship for the period of time listed below. Where a warrantable condition exists, Smithco will repair the Product at no cost to you including diagnosis, labor (at the Smithco standard labor rate, subject to the Smithco flat rate schedule), and parts.

## Warranty Duration is:

- (1) Two years, 1500 operational hours\* from the date of delivery to the original purchaser or three years from the date of original manufacturer of the product, whichever occurs first. (\*Products equipped with hour meter).
- (2) Products used in rental situations are covered for 90 days from date of delivery to original user/ renter.

## Owner Responsibilities:

As the Product owner, you are responsible for required maintenance and adjustments stated in your Owner's Manual. Failure to perform required maintenance and adjustments can be grounds for disallowing a warranty claim. **You are particularly responsible to train all present and future operators of this product on the safe operation of this product at your location.**

## Instructions for Obtaining Warranty Service:

You are responsible for notifying the Authorized Smithco Products Distributor from whom you purchased the Product as soon as you believe a warrantable condition exists and not later than 30 days from discovery of the condition.

If you need help locating an Authorized Smithco Distributor, or if you have questions regarding your warranty rights or responsibilities, you may contact us at:

Smithco Product Support Department  
200 W Poplar PO Box 487  
Cameron, Wisconsin 54822

Telephone: 1-800-891-9435

E-Mail: [ProductSupport@smithco.com](mailto:ProductSupport@smithco.com)

## Maintenance Parts:

Parts scheduled for replacement as required maintenance ("Maintenance Parts"), are warranted for the period of time up to the scheduled replacement time for that part.

### Items/Conditions Not Covered:



Not all product failures or malfunctions that occur during the warranty period are defects in materials or workmanship. The items/conditions listed below are not covered by this warranty:



Product failures which result from the use of non-Smithco replacement parts, or from installation and use of add-on, modified, or unapproved accessories are not covered.



Product failures which result from failure to perform required maintenance and/or adjustments are not covered.



Product failures that result from operating the Product in an abusive, negligent or reckless manner are not covered.



This warranty does not apply to parts subject to consumption through use, unless found to be defective. Examples of parts which are consumed, or used up, during normal Product operation include, but are not limited to: blades, tines, teeth, scarifiers, rakes, plates, wear plates, castor wheels, tires, batteries, filters, belts, nozzles, etc.



This warranty does not apply to failures caused by out-side influence. Items considered to be outside influence include, but are not limited to, weather, storage practices, contamination, use of unapproved coolants, lubricants, additives, or chemicals, etc.



This warranty does not apply to normal “wear and tear” items. Normal “Wear and Tear” includes, but is not limited to, damage to seats due to wear or abrasion, worn painted surfaces, scratched decals or windows, etc.



Smithco may require the return of failed parts or components in order to determine the validity of any warranty claim.



Smithco will not be obligated to replace components of other manufacturers if inspection by the original component manufacturer indicates that failure was due to normal wear and tear, expected consumption through use or improper care or service.

#### **Other Legal Disclaimers:**

The above remedy for product defects through repair or replacement by an authorized Smithco distributor or dealer is the purchaser’s sole remedy for any defect. This warranty gives you specific legal rights, and you may also have other rights which vary from state to state.

**THERE ARE NO OTHER EXPRESS WARRANTIES OTHER THAN THOSE SET FORTH ABOVE. ALL IMPLIED WARRANTIES OF MERCHANTABILITY AND FITNESS FOR USE ARE LIMITED TO THE DURATION OF THE LIMITED WARRANTIES CONTAINED HEREIN.**

Some states may not allow limitations on how long an implied warranty lasts, so the above limitation may not apply to you.

**THE SMITHCO COMPANY IS NOT LIABLE FOR INDIRECT, INCIDENTAL OR CONSEQUENTIAL DAMAGES IN CONNECTION WITH THE USE OF THE PRODUCT, INCLUDING ANY COST OR EXPENSE OF PROVIDING A SUBSTITUTE PRODUCT OR SERVICE DURING PERIODS OF MALFUNCTION OR NON-USE.**

Some states may not allow the exclusion of indirect, incidental or consequential damages, so the above exclusion may not apply to you.

**Smithco neither assumes, nor authorizes any person to assume for it, any other liability in connection with the sale or use of this product.**

**SMITHCO, INC.**

**Wayne, PA 19087**

