

Parts & Service



Super Star X-Treme
43-000-B

SN: 43057

March 2007

Product Support:

Hwy 55 & Poplar Ave; Cameron WI 54822

1-800-891-9435 productsupport@smithco.com

CONTENTS

Introduction

Introduction 1-3
Introduction 1
Safe Practices 2
Specifications 3
Optional Equipment 3

Service

Service 4-11
Maintenance 4-6
Service Chart 7
End User's Service Chart 8
Adjustments 9-11
Storage 11

Diagrams

Diagrams 12-15
Wiring Diagram 12-13
Hydraulic Diagram 14-15

Parts

Parts 16-41
Main Frame 16-17
3 Wheel Drive Front Fork 18-19
Linkage 20-23
Gas Tank 24-25
Oil Tank 26-27
Engine 28-31
Rear Axle 32-33
Rake Lift 34-35
13-729 2-Bank Hydraulic Valve 36-37
76-238 Front Wheel Motor 38-39
42-002 Rear Wheel Motor 40-41

Accessories

Accessories 42-103

43-003 Hydraulic Sand Plow 42-45
42-011 Sand Plow(Steel & Aluminum) 46-47
42-136 60" Aluminum Sand Plow 48-49
42-223 Adjustable Disc Edger 50-51
42-008 Sand Cultivator 52-53
42-340 Sand Cultivator w/ Spring Tine 54-55
42-341 Sand Cultivatore w/ Castor Wheels 56-57
42-010 Construction Leveling Blade ... 58-59
42-210 Grader Blade Kit 60-61
42-178 Infield Scarifier(vertical blades) ... 62-65
42-179 Infield Scarifier(chisel blades) 66-69
42-285 Scarifier w/ Vertical Blades ... 70-73
42-026 84"(213cm)Stainless Rake 74-77
42-128 72"(183cm) Stainless Rake 78-81
13-438 Rake with Finishing Blades 82-83
13-684 Sand Rake Brush Kit 84-85
13-298 Fan Rake 86-87
13-319 Fan Rake Kit..... 86-87
26-007 Professional Field Finisher 88-89
42-185 Drag Mat Kit 88-89
43-002 Flex Field Finisher w/ Brush ... 90-93
26-008 Flex Action Field Finisher 94-97
43-043 Brush Kit for 26-008 98-99
45-282 Green Star RBS Spiker 100-101
42-586 Green Star RBS Main Frame102-103

Reference 105-106

Decal List 105
Quick Reference 106
Warranty Inside Back Cover

Reference

Thank you for purchasing a **SMITHCO** product.

Read this manual and all other manuals pertaining to the Super Star X-treme carefully as they have safety, operating, assembly and maintenance instructions. Failure to do so could result in personal injury or equipment damage.

Keep manuals in a safe place after operator and maintenance personnel have read them. Right and left sides are from the operator's seat, facing forward.

All **SMITHCO** machines have a Serial Number and Model Number. Both numbers are needed when ordering parts. The serial number plate on the Super Star X-treme is located on the rear axle. Refer to engine manual for placement of engine serial number.

For easy access record your Serial and Model numbers here.

SMITHCO		DATE OF MFG.
WAYNE, PENNSYLVANIA 19087 USA 610-688-4009 Fax 610-688-6069		<input type="text"/>
SERIAL NO.	kW/hp	
<input type="text"/>	<input type="text"/>	
MODEL NO.	kg/lb	
<input type="text"/>	<input type="text"/>	



Information needed when ordering replacement parts:

1. Model Number of machine
2. Serial Number of machine
3. Name and Part Number of part
4. Quantity of parts

SAFE PRACTICES

1. It is your responsibility to read this manual and all publications associated with this machine (engine, accessories and attachments).
2. Never allow anyone to operate or service the machine or its attachments without proper training and instructions. Never allow minors to operate any equipment.
3. Learn the proper use of the machine, the location and purpose of all the controls and gauges before you operate the equipment. Working with unfamiliar equipment can lead to accidents.
4. Wear all the necessary protective clothing and personal safety devices to protect your head, eyes, ears, hands and feet. Operate the machine only in daylight or in good artificial light.
5. Inspect the area where the equipment will be used. Beware of overhead obstructions and underground obstacles. Stay alert for hidden hazards.
6. Never operate equipment that is not in perfect working order or without decals, guards, shields, or other protective devices in place.
7. Never disconnect or bypass any switch.
8. Carbon monoxide in the exhaust fumes can be fatal when inhaled, never operate a machine without proper ventilation.
9. Fuel is highly flammable, handle with care.
10. Keep engine clean. Allow the engine to cool before storing and always remove the ignition key.
11. After engine has started, machine must not move. If movement is evident, the neutral mechanism is not adjusted correctly. Shut engine off and readjust so the machine does not move when in neutral position.
13. Never use your hands to search for oil leaks. Hydraulic fluid under pressure can penetrate the skin and cause serious injury.
14. This machine demands your attention. To prevent loss of control or tipping of the vehicle:
 - A. Use extra caution in backing up the vehicle. Ensure area is clear.
 - B. Do not stop or start suddenly on any slope.
 - C. Reduce speed on slopes and in sharp turns. Use caution when changing directions on slopes.
 - D. Stay alert for holes in the terrain and other hidden hazards.
15. Before leaving operator's position for any reason:
 - A. Disengage all drives.
 - B. Lower all attachments to the ground.
 - C. Shut engine off and remove the ignition key.
16. Keep hands, feet and clothing away from moving parts. Wait for all movement to stop before you clean, adjust or service the machine.
17. Keep the area of operation clear of all bystanders.
18. Never carry passengers.
19. Stop engine before making repairs/adjustments or checking/adding oil to the crankcase.
20. Use parts and materials supplied by SMITHCO only. Do not modify any function or part.

These machines are intended for professional maintenance on golf courses, sports turf, and any other area maintained turf and related trails, paths and lots. No guaranty as to the suitability for any task is expressed or implied.



WEIGHTS AND DIMENSIONS

Length	64" (1.63 m)
Width	57" (1.45 m)
Height	47" (1.19 m)
Wheel Base	41" (1.04 m)
Weight	950 lbs. (451 kg)

SOUND LEVEL

At Ear Level	87 dB
At 3ft (.914 m)	96 dB
At 30 ft (9.14 m)	84 dB

ENGINE

Make	Briggs and Stratton Vanguard
Model#	303447
Type / Spec#	1131E1
Horsepower	18 hp (13kW)
Fuel	Unleaded 87 Octane Gasoline Minimum
Cooling System	Air Cooled
Lubrication System	Full Pressure
Alternator	16 amp

WHEELS & TIRE

Three: 22 X 11 - 10.0 Knobby Tires 5 psi (.35 bar)
 Front tire fluid filled to 80 lbs. total 45.5 pints of windshield washer fluid or equivalent.

Speed

Forward Speed	0 to 11 m.p.h. (0-18 kph)
Reverse Speed	0 to 5 m.p.h. (0-8 kph)

BATTERY

	Automotive Type 45-12 Volt
BCI Group	Size 45
Cold Cranking Amps	480
Ground Terminal Polarity	Negative (-)
Maximum Length	9" (23 cm)
Maximum Width	5.38" (14 cm)
Maximum Height	9" (23 cm)

FLUID CAPACITY

Crankcase Oil	See Engine Manual
Fuel	20 quarts (18.93 liters)
Hydraulic Fluid	20 quarts (18.93 liters)
Grade of Hydraulic Fluid	SAE 10W-40 API Service SJ or higher Motor Oil



MAINTENANCE



Before servicing or making adjustments to machine, stop engine and remove key from ignition.

NOTE: Use all procedures and parts prescribed by the manufacturer's. Read the engine manual.

LUBRICATION

Use No. 2 General purpose Lithium Base Grease and lubricate every 100 hours. The Super Star X-treme has seven grease fittings. Two on the rake lift, one on the shift arm, one on the speed boss arm, one on the speed boss relay, one on the attachment lift cylinder rod end and one on the foot pedal.

AIR CLEANER ON ENGINE

1. Unhook clips on both sides of cover and remove cover.
2. Carefully slide pre-cleaner of cartridge. To service pre-cleaner, wash in liquid detergent and water. Squeeze dry in clean cloth. Saturate in engine oil. Squeeze in clean absorbent cloth to remove excess oil. Replace if very dirty or damaged.
3. Remove knob and plate. Carefully remove cartridge to prevent debris from entering carburetor. To service cartridge, clean by tapping gently on flat surface. Do not oil cartridge. Replace if very dirty or damaged.

NOTE: Do not use petroleum solvents, e.g., kerosene, which will cause cartridge to deteriorate. Do not use pressurized air to clean cartridge. Pressurized air can damage cartridge.

4. Reinstall cartridge, plate and knob.
5. Reassemble pre-cleaner on cartridge.
6. Replace cover and reattach clips to body.

REMOTE AIR CLEANER

1. Unclip the two clips, remove the cover and pull out the element.
2. To service, clean by tapping gently on flat surface. Do not oil. Replace if very dirty or damaged.
3. Clean out the inside of the body and cover.
4. Place the element into the body and put the cover back on.

TOWING

When it is necessary to move the Super Star X-treme without engine running, bypass valve built into hydrostatic pump must be "open" by turning it counterclockwise. The valve is located on the right side of the pump. An "open" valve allows fluid to pass through the wheels freely. When normal, driven, operation is desired, valve should be "closed" by turning it clockwise. Failure to "close" the valve with engine running means no power to wheels. The machine can be moved for a short distance with the engine off, but we **do not** recommend this as a standard procedure. When towing **do not** tow the machine faster than 2-3 MPH (3-5 km/h) because the drive system may be damaged. The tires may lock up if the machine is towed too fast. If this occurs, stop towing the machine. If the machine must be moved a considerable distance, transport it on a truck or trailer.



TIRE PRESSURE

Caution must be used when inflating a low tire to recommended pressure. Over inflating can cause tires to explode. Tires should be 5 psi (0.35 bar). Improper inflation will reduce tire life considerably.

ENGINE

Change and add oil according to chart below. Do not overfill. Use a high quality detergent oil classified "For Service SJ or higher" SAE 30 oil. Use no special additives with recommended oils. Do not mix oil with gasoline.

SAE VISCOSITY GRADES

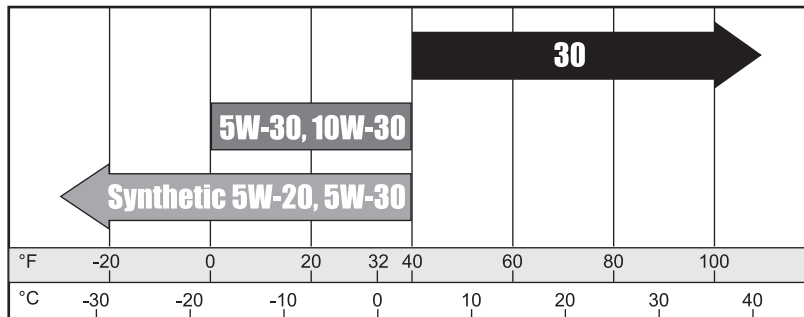

Starting Temperature Range Anticipated Before Next Oil Change

Air cooled engine run hotter than automotive engines. Use of multi-viscosity oils (10W-30, etc.) above 40° F (4° C) will result in high oil consumption and possible engine damage. Check oil level more frequently if using these types of oils.

SAE 30 oil, if used below 40° F (4° C), will result in hard starting and possible engine bore damage due to inadequate lubrication.

HYDRAULIC OIL

1. Use SAE 10W-40 API Service SJ or higher motor oil.
2. For proper warranty, change oil every 500 hours or annually, which ever is first and change filter after the first 20 hours, then at 100 hours, then every 250 hours thereafter.
3. The oil level should be 2" to 2 1/2" from top of tank when fluid is cold. Do not overfill.
4. After changing oil and/or filter, run the machine for a few minutes. Check oil level and for leaks.
5. Always use caution when filling hydraulic oil tank or checking level to keep system free of contaminants. Check and service more frequently when operating in extremely cold, hot or dusty conditions.
6. If natural color of fluid is black or smells burnt, it is possible that an overheating problem exists.
7. If fluid becomes milky, water contamination may be a problem.
8. If either of the above conditions happen, change oil and filter immediately after fluid is cool and find cause. Take fluid level readings when system is cold.
9. In extreme temperatures you can use straight weight oil. We recommend SAE 30W API Service SJ or higher when hot (above 90°F (33°C)) and SAE 10W API Service SJ or higher when cold (below 32°F (0°C) ambient temperature. Use either motor oil or hydraulic oil, but do not mix.
10. Oil being added to the system must be the same as what is already in the tank. Mark tank fill area as to which type you put in.

MAINTENANCE

WHEEL MOUNTING PROCEDURE

1. Turn machine off and remove key.
2. Block one of the other wheels.
3. Loosen nuts slightly on wheel to be removed.
4. Jack up machine being careful not to damage underside of machine.
5. Remove nuts. Remove wheel.
5. Place new wheel on hub lining up bolt holes.
6. Torque nuts to 64-74 ft/lb (87-100 Nm) using a cross pattern. Re-torque after first 10 hours and every 200 hours thereafter.
7. Lower machine to ground and remove blocks and jack.

BATTERY

Batteries normally produce explosive gases which can cause personal injury. Do not allow flames, sparks or any ignited object to come near the battery. When charging or working near battery, always shield your eyes and always provide proper ventilation.

Battery cable should be disconnected before using "Fast Charge".

Charge battery at 15 amps for 10 minutes or 7 amps for 30 minutes. Do not exceed the recommended charging rate. If electrolyte starts boiling over, decrease charging.

Always remove grounded (-) battery clamp first and replace it last. Avoid hazards by:

1. Filling batteries in well-ventilated areas.
2. Wear eye protection and rubber gloves.
3. Avoid breathing fumes when electrolyte is added.
4. Avoid spilling or dripping electrolyte.



WARNING

Battery Electrolyte is an acidic solution and should be handled with care. If electrolyte is splashed on any part of your body, flush all contact areas immediately with liberal amounts of water. Get medical attention immediately.

JUMP STARTING



WARNING

Use of booster battery and jumper cables. Particular care should be used when connecting a booster battery. Use proper polarity in order to prevent sparks.

To jump start (negative grounded battery):

1. Shield eyes.
2. Connect ends of one cable to positive (+) terminals of each battery, first (A) then (B).
3. Connect one end of other cable to negative (-) terminal of "good" battery (C).
4. Connect other end of cable (D) to engine block on unit being started (NOT to negative (-) terminal of battery)

To prevent damage to other electrical components on unit being started, make certain that engine is at idle speed before disconnecting jumper cables.

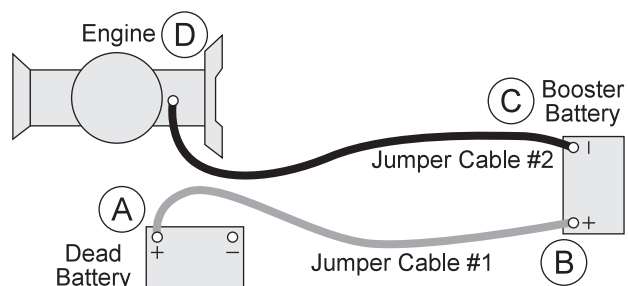



Before servicing or making adjustments to the machine, stop engine, set park break, block wheels and remove key from ignition.



Follow all procedures and **ONLY** use parts prescribed by the manufacturer. Read the engine manual before maintenance.

The suggested maintenance checklist is not offered as a replacement for the manufacturer's engine manual but as a supplement. You must adhere to the guidelines established by the manufacturer for warranty coverage. In adverse conditions such as dirt, mud or extreme temperatures, maintenance should be more frequent.

Maintenance Service Interval	Maintenance Procedure
After the first 8 operating hours	Torque the wheel lug nuts. (64-74 ft/lb (87-100 Nm))
	Change the engine oil filter.
	Change the hydraulic filter.
After the first 20 operating hours	Change oil filter after first 20 and first 100 hours.
Before each use daily	Check the engine oil.
	Check the hydraulic fluid level.
	Check the tire pressure.
	Check condition of hydraulic hoses and fittings.
	Inspect and clean the machine.
	Inspect cooling system.
Every 25 hours	Check the battery fluid level and cable connections.
	Change oil when operating under heavy load or high
Every 50 hours	Change the engine oil and filter.
Every 100 hours	Check engine for leaks or loose parts.
	Check air cleaner.
	Check tire pressure (5 psi (.035 bar)).
	Torque the wheel lug nuts. (64-74 ft/lb (87-100 Nm))
	Grease Machine.
	Check belt tension (where needed)
Every 250 hours	Change oil filter
	Change hydraulic filter
	Clean battery terminals
Every 400 hours	Check spark plugs
Every 500 hours or yearly	Lubricate machine
	Visual inspection of machine and hydraulic hoses
	Change oil.
	Torque lug nuts.
	Check battery terminals and electrolyte level.
	Change all filters.



END USER'S SERVICE CHART

Duplicate this page for routine use.

Service

Maintenance Check Item	For the week of:						
	Mon	Tues.	Wed.	Thurs.	Fri.	Sat.	Sun.
Check the Safety Seat Switch							
Check Steering Operation							
Check the fuel level							
Check the engine oil level.							
Check the condition of the air filter							
Clean the engine cooling fins.							
Check for unusual engine noises							
Check the hydraulic oil level							
Check hydraulic hoses and fittings for damage							
Check for fluid leaks.							
Check the tire pressure (5 psi)							
Check the Instrumentation							
Inspect electrical system for frayed wires							
Check park brake adjustment							
Change oil filter.							
Change oil.							
Ensure all warning decals are intact.							

Areas of Concern		
Inspection Performed by:		
Item	Date	Information

ADJUSTMENTS

RAKE LIFT CYLINDER

Completely lower Rake Lift. Remove cotter pin (A) and clevis pin (B). Place attachment lift arms (C) at $\frac{1}{16}$ " above cross member (D) on Rake Lift. Loosen jam nut (E). Twist cylinder extension (F) so clevis pin end of cylinder extension lines up with holes in attachment lift arm. Replace clevis and cotter pins. Tighten jam nut. Raise and lower Rake Lift to check for proper clearance.



When the rear rake attachment is lowered while the machine is in forward motion, the forward speed of the machine will slow drastically. Operator should be prepared for a rapid change in speed.

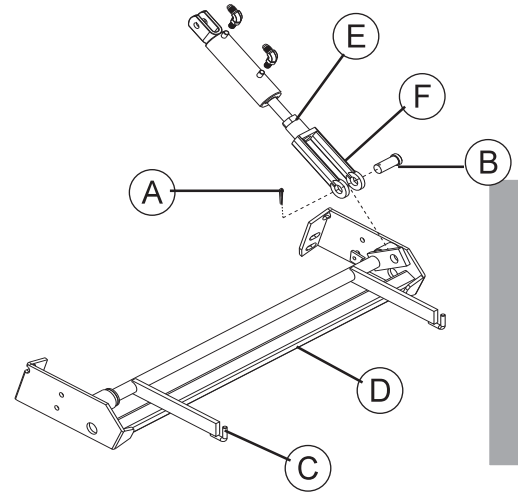

Service

SPEED BOSS

Speed Boss allows the machine to operate at a proper speed while raking sand traps on golf courses. This speed boss has been factory set at an average speed of 3-4 m.p.h. (5-6.5 kph). The Speed Boss will only limit the speed while the rake is lowered into the operating position.

Quick Disconnect Ball Joints (A) are used in applications where the housing needs to be easily disconnected from the ball stud. This is accomplished by pulling back the spring-loaded outer housing.

The speed setting may be adjusted by turning the Ball Joint (A) counterclockwise to make the machine operate slower or turn clockwise to go faster. Tighten jam nut. Check to make sure nothing is binding and test drive to check desired speed.

For RBS System, Spiker and Grader Box remove the speed boss arm and the speed boss rod from machine so it does not interfere with other operations.

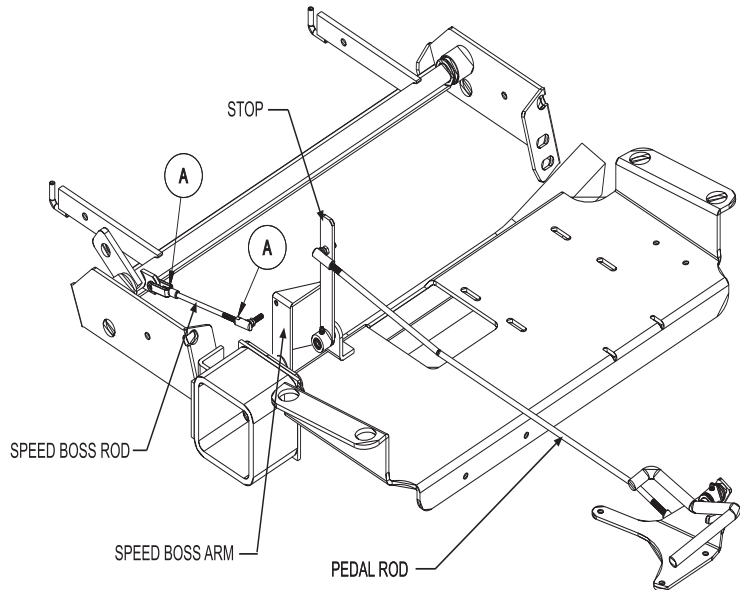

ADJUSTMENTS (CONTINUED)

WHEEL 'CREEP' ADJUSTMENT

'Creep' is when engine is running and hydrostatic transmission is in neutral, but due to inadequate alignment, wheels still move. Do the following procedures to stop this motion.

1. Lift up and support machine so all wheels are off the ground and can turn freely.
2. On the top of the pump there is a ball bearing on a creep arm. Loosen the bolt (A).
3. With engine running adjust the ball bearing right or left in slot so ball bearing centers on the swash arm.
4. Tighten all fasteners and test by using foot pedal linkage to see that the "creep" is removed.
5. Turn engine off and lower machine.

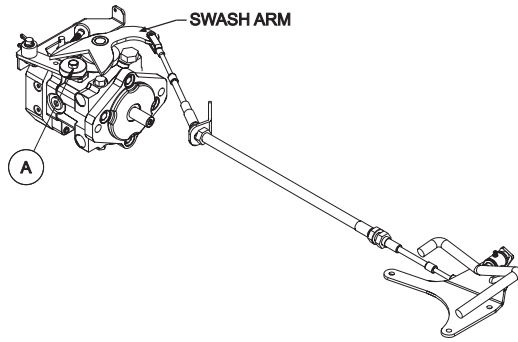

PARK BRAKE

The park brake is located on the right hand side of the machine and operates a brake on the right rear wheel. Push lever forward to engage and pull back to disengage.

To adjust turn the knob on the end of the handle. For further adjustment you may turn the yokes (A) clockwise to tighten and counter clockwise to loosen.

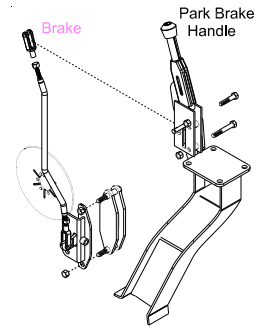

ADJUSTMENTS (CONTINUED)

TO ADJUST FOOT PEDAL THROTTLE CABLE

1. Jack up unit so that all drive wheel are off the ground. (Use jack stands)
2. Start the engine, make certain that the hand throttle is in the idle position (1200 engine RPM).
3. Engine speed must increase as soon as the foot pedal begins to move in either direction. At the full forward position, the engine RPM must be 3600 RPM \pm 100.
4. Minor adjustment can be made by backing out (unscrewing) (Ref A) until you reach full engine RPM with the foot pedal fully depressed in the forward position. Be sure to recheck after the nuts are fully tightened.
5. Major adjustment needs to be made at engine by pulling the slack out of the cable. Loosen the screw in the wire block that is clamped onto the end of the cable (at the engine) and slide it up to the cable block that is through the throttle plate. Do not let the throttle plate move to increase idle speed. Tighten the screw.
6. Test run to determine that there is no binding and that engine idle speed is 1200 RPM and that it is 3600 RPM at full forward position of the foot pedal.

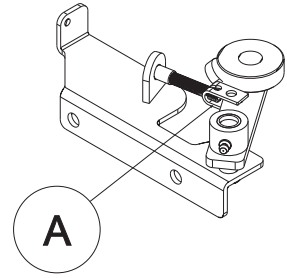

STORAGE

When storing, remove the key from the key switch to avoid unauthorized persons from operating machine.

1. Before storing clean machine thoroughly.
2. Check bolts and nuts, tighten as necessary.
3. Make all repairs that are needed and remove any debris.
4. Remove the battery, adjust the electrolyte level and recharge it. Store the battery in a dry, dark place.
5. Store in a clean and dry area, but NOT near a stove, furnace or water heater which uses a pilot light or any device that can create a spark.
6. Engines stored over 30 days need to be protected or drained of fuel to prevent gum from forming in a fuel system or on essential carburetor parts. Check the engine manual and follow the instructions for the storage of the engine.

WIRING DRAWING

Color Code Chart

Bl	Blue
Br	Brown
Y	Yellow
Grn	Green
O	Orange
R	Red
B	Black
P	Purple
W	White

Diagrams

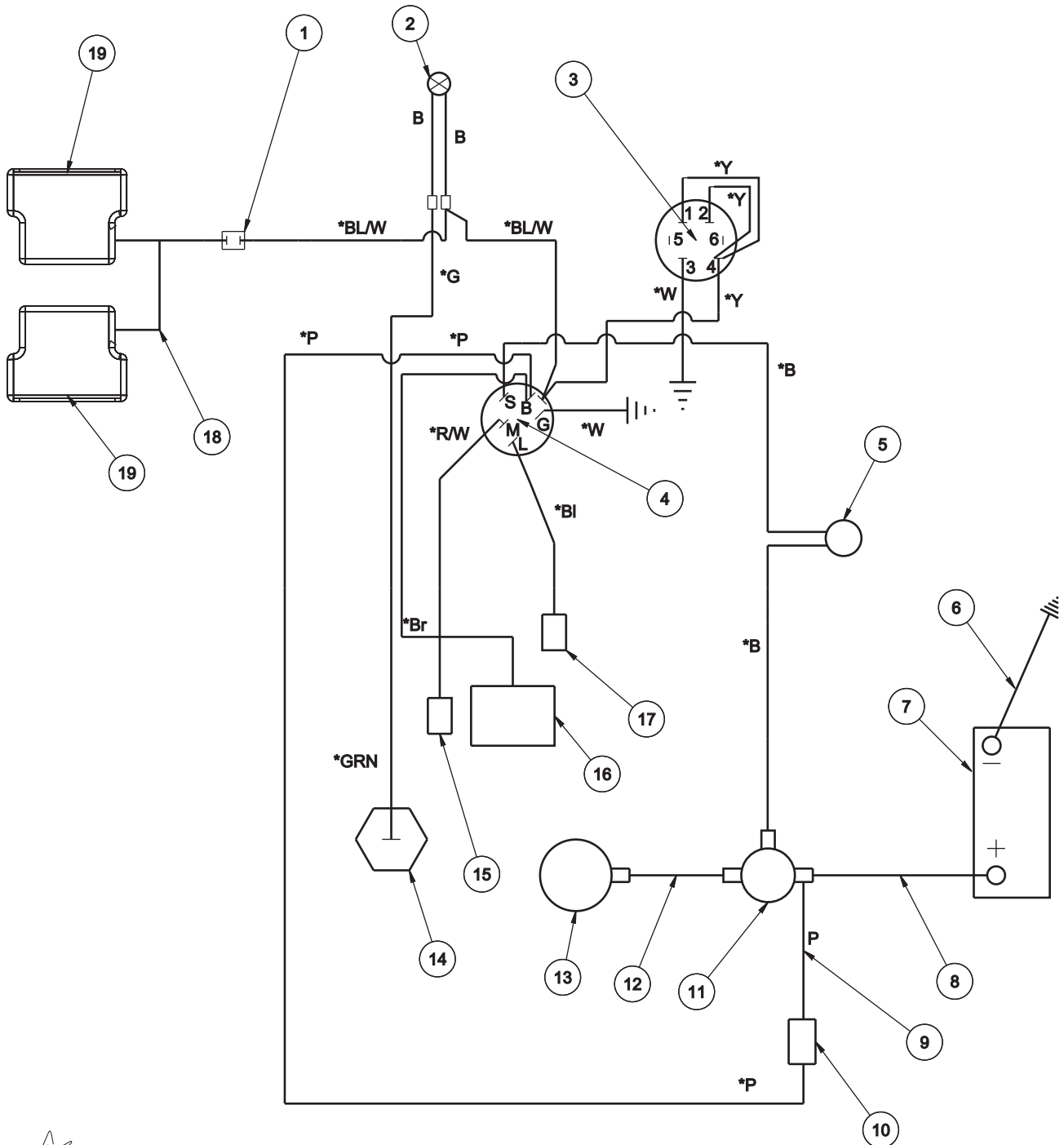

WIRING PARTSLIST

REF #	PART #	DESCRIPTION	QUANTITY
1	12-003	Toggle Switch	1
	15-472	Switch Boot	1
2	50-359	Oil Pressure Warning Light	1
3	12-017	Hour Meter	1
4	13-488	Ignition Switch	1
	76-310	Key Set	1
5	14-292	Seat Switch	1
6	76-327	Ground Battery Cable	1
7		Battery (not included)	
8	75-518	Battery Cable	1
9	42-252	Wire, Circuit Breaker to Solenoid	1
10	8975	30 Amp Circuit Breaker	1
	8977	Circuit Breaker Boot	1
11	13-492	Solenoid (B & S# 807829)	1
12	22-017	Cable Black	1
13		Starter (on engine)	1
14	13-491	Oil Sender (on engine B & S# 491657)	1
15		Stop Switch Terminal (on engine)	1
16		Rectifier (on engine)	1
17		After Fire Solenoid (on engine)	1
18	42-319	Light Wire Harness	1
19	42-317	Lights	2
	42-317-01	Replacement Bulb	
	42-763	Wire Harness (includes all wire colors with *)	1
	42-387	Wire Harness (Solenoid to ENGINE)	1

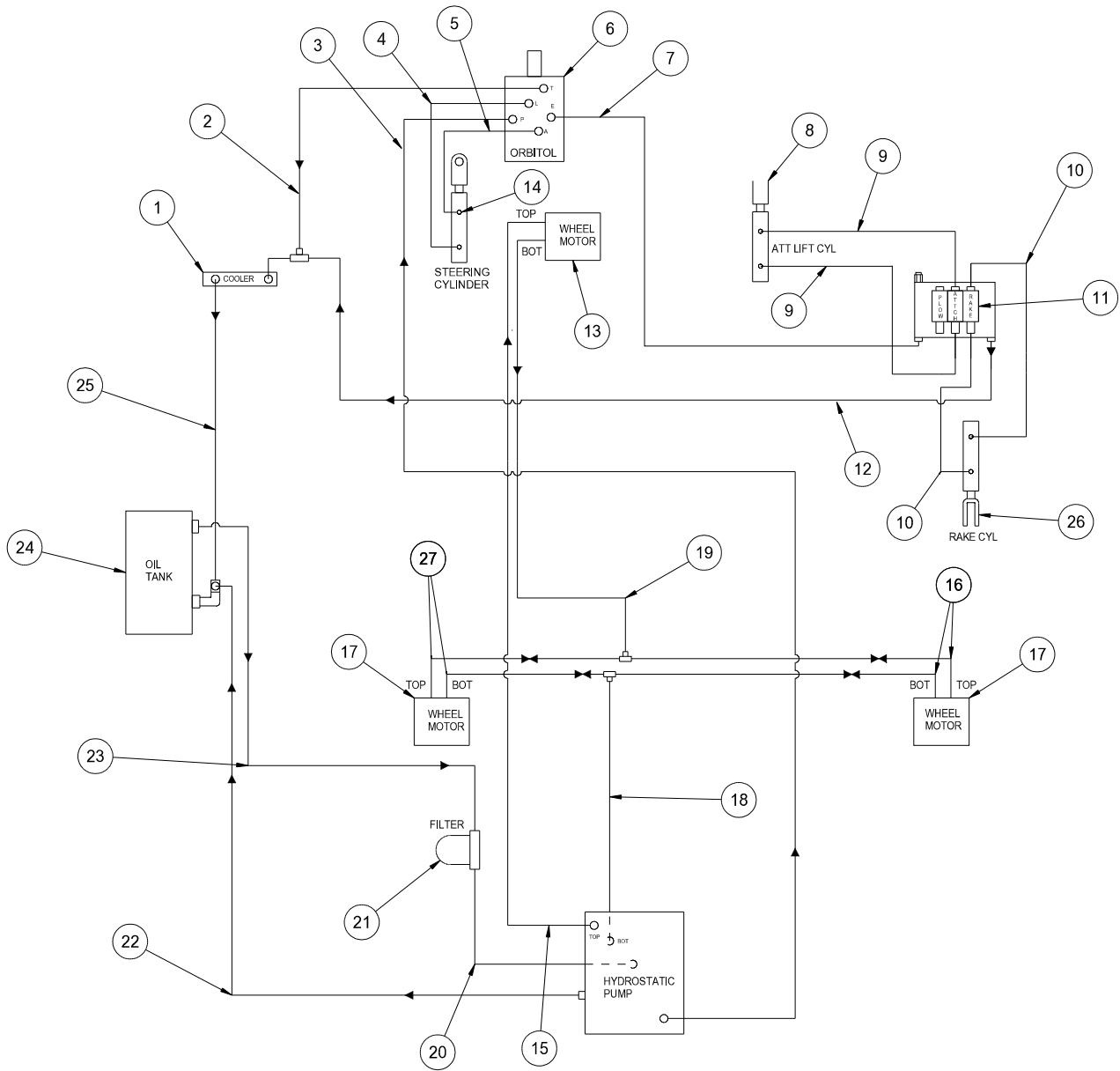

HYDRAULIC PARTSLIST

REF #	PART #	DESCRIPTION	QUANTITY
1	42-265	Cooler	1
2	43-034	Hydraulic Hose - 32"	1
3	43-033	Hydraulic Hose - 48"	1
4	43-029	Hydraulic Hose - 24"	1
5	43-035	Hydraulic Hose - 20"	1
6	34-103	Orbitol	1
7	43-036	Hydraulic Hose - 55"	1
8	10-135	Attachment Lift Cylinder	1
	18-154	Rod End	1
	HNJ-58-18	Jam Nut ⁵ / ₈ -18	1
9	42-047	Hydraulic Hose - 32"	2
10	42-048	Hydraulic Hose - 14"	2
11	13-729	2-Bank Valve	1
12	42-045	Hydraulic Hose - 41"	1
13	76-238	Front Wheel Motor	1
14	75-714	Steering Cylinder	1
15	43-070	Hydraulic Hose - 98"	1
16	43-094	Hydraulic Tube - RH	2
17	13-615	Rear Wheel Motor	2
18	43-032	Hydraulic Hose - 40"	1
19	43-071	Hydraulic Hose - 69.5"	1
20	8832-27	³ / ₄ " Suction Hose - 27	1
	18-222	Hose Clamp	2
21	23-006	Oil Filter	1
	23-031	Replacement Filter only	
22	42-787	Hydraulic Hose - 36 ¹ / ₂ "	1
23	8832-42.5	³ / ₄ " Suction Hose - 42 ¹ / ₂ "	1
	18-222	Hose Clamp	2
24	42-005	Oil Tank	1
	13-586	Filler Breather	1
25	42-256	Hydraulic Hose 18 ³ / ₄ "	1
26	13-357	Rake Cylinder	1
	42-040	Yoke End	1
	HNJ-34-16	Jam Nut ³ / ₄ - 16	2
27	43-095	Hydraulic Tube -LH	2

Diagrams

Pump Displacement	.913 in ³ /rev	Charge Pump Displacement	.33 in ³ /rev
Pump Input Speed (up to)	3600 rpm	Max. Inlet Vacuum	5 in. Hg
Max. Operating Pressure	2500 peak psi	Max. Case Pressure	25 psi
Implement Setting	700-1000 psi	Relief Valve Pressure (set at)	2500 psi
13-729 Hydraulic Valve (2 bank)	900 psi		



MAINFRAME COMMON DRAWING

Parts

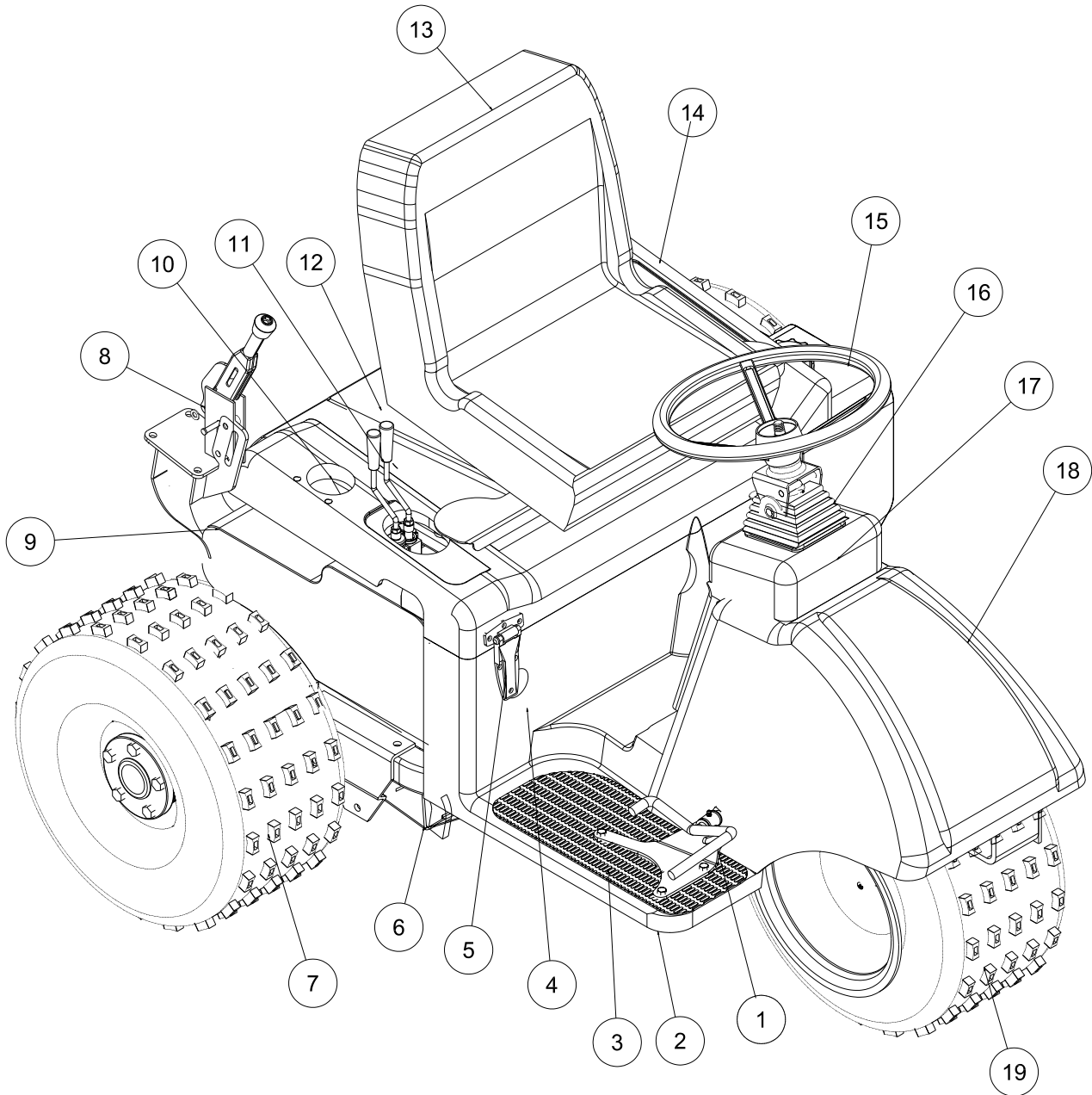

MAIN PARTS COMMON LIST

REF#	PART#	DESCRIPTION	QUANTITY
1	42-790	Foot Pedal	1
2	42-780	Floor Panel (fiberglass)	1
3	42-767	Right Floor Mat	1
	42-768	Left Floor Mat	1
4	12-017	Hour Meter	1
5	27-055	Hinge	2
6	43-132	Main Frame	1
7	42-161	Knobby Tire and Wheel	2
	45-021-01	Tire 22 x 11 - 10 Knobby Type	2
	42-161-02	Wheel	2
	60-268	Lug Bolt	10
8	60-106	Park Brake Lever	1
9	42-006	Gas Tank	1
	15-492	Cap	1
10	42-786	Plastic Cup Holder	1
11	78-418	Valve Handle	2
12	42-772	Seat Panel	1
	8803-17	Trim w/ Black Lace	1
13	14-518	Adjustable Low Back Seat	1
14	42-779	Seat Panel (fiberglass)	1
15	13-718	Steering Wheel	1
16	76-364	90° Black Boot (comes with 76-362)	1
	76-362	Tilt Steering Mechanism	1
17	42-782	Console (fiberglass)	1
18	42-471	Nose Cone (fiberglass)	1
	HSTP-14-20-100	Phillips Machine Screw 1/4 - 20 x 1	6
	78-274	Cage Nuts	2
	HNTL-14-20	Lock Nut 1/4 - 20	6
19	43-058	Tire and Wheel	1
	45-021-01	Tire 22 x 11 - 10 Knobby Type	1
	43-058-01	Wheel	1
	8839	Windshield Washer Fluid or Equivalent (Front tire and wheel are fluid filled to 80 lbs. Total)	45.5 pints



FRONT FORK DRAWING

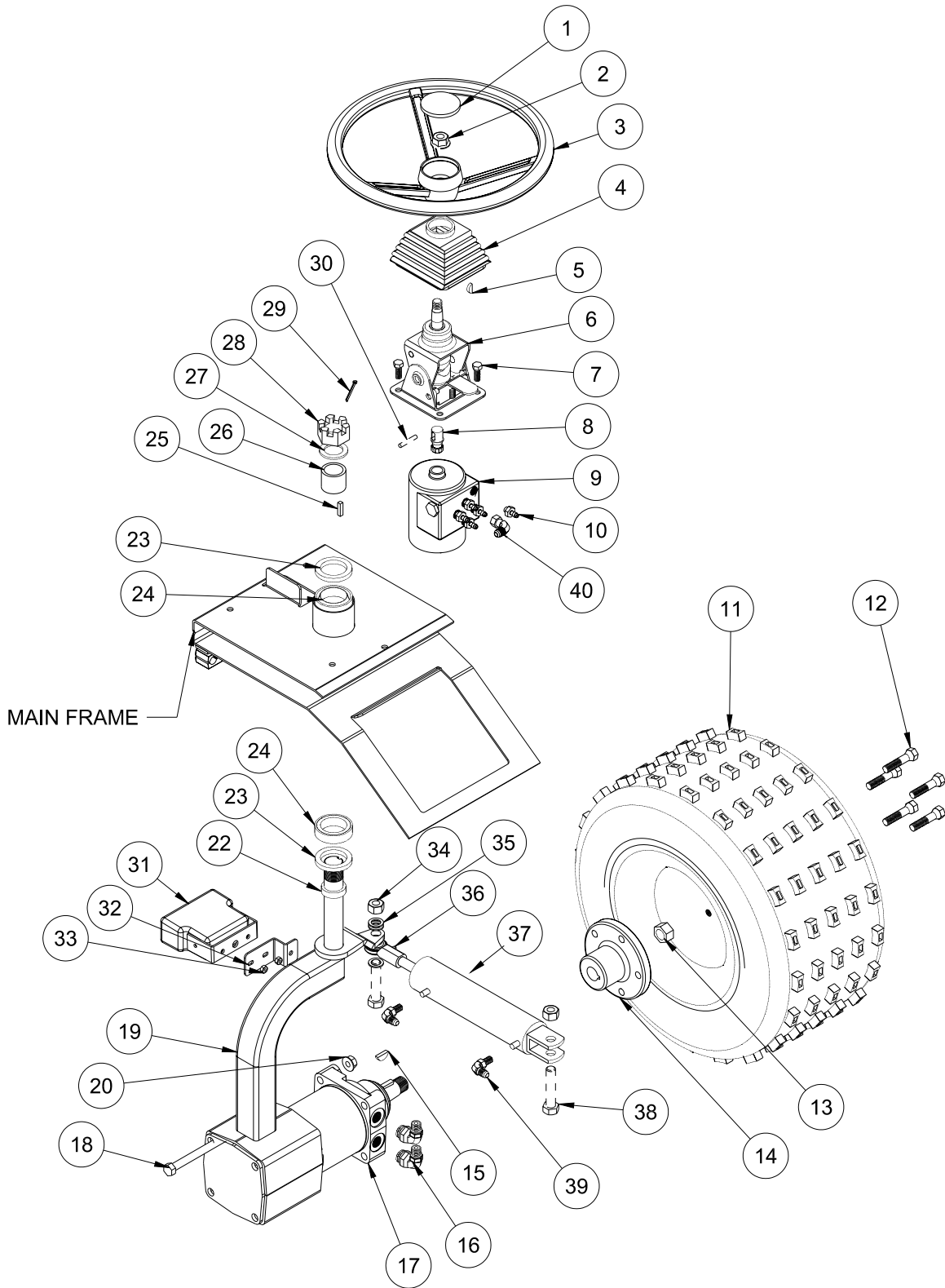

FRONT FORK PARTSLIST

REF#	PART#	DESCRIPTION	QUANTITY
1	13-726	Center Cap	1
	27-077	Decal, Smithco Round	1
2	HNTL-58-11	Lock Nut $\frac{5}{8}$ - 11	1
3	13-718	Steering Wheel 13"	1
4	76-364	Tilt Steering Boot (comes with 76-362)	1
5	HWK-316-075	Woodruff Key $\frac{3}{16} \times \frac{3}{4}$	1
6	76-362	Tilt Steering Mechanism	1
7	HB-516-18-125	Bolt $\frac{5}{16}$ - 18 x $1\frac{1}{4}$	2
	HNTL-516-18	Lock Nut $\frac{5}{16}$ - 18	2
8	48-187	Stub Shaft	1
9	34-103	Orbitrol	1
10	18-169	Adapter 3/8 SAE	5
11	43-058	Knobby Tire and Wheel	1
	45-021-01	Tire 22 x 11 - 10 Knobby Type	1
	43-058-01	Wheel	1
	8839	Windshield Washer Fluid or Equivalent	43.5 pints
12	60-268	Lug Bolts $\frac{1}{2}$ - 20 x $1\frac{5}{16}$	5
13	42-002-12	Nut $\frac{3}{4}$ - 16 (part of 76-238)	1
14	13-033	Hub	1
15	HWK-14-100	Woodruff Key $\frac{1}{4}$ - 1 (part of 76-238)	1
16	18-350	90° Seal Lok Elbow	2
17	76-238	Wheel Motor	1
18	HB-12-13-650	Bolt $\frac{1}{2}$ - 13 x $6\frac{1}{2}$	4
19	43-053	Front Fork	1
20	HNFL-12-13	Flange Whiz Lock Nut $\frac{1}{2}$ - 13	4
22	20-141	Spacer	1
23	20-142	Oil Seal	2
24	20-143	Bearing	2
25	HKSQ-14-100	Square Key $\frac{1}{4} \times \frac{1}{4} \times 1$	1
26	43-027	Shaft Spacer	1
27	HMB-114-10	Machine Bushing $1\frac{1}{4} \times 10GA$	1
28	HNA-114-12	Axle Nut $1\frac{1}{4}$ - 12	1
29	HP-18-200	Cotter Pin $\frac{1}{8} \times 2$	1
30	HRP-14-150	Roll Pin $\frac{1}{4} \times 1\frac{1}{2}$	1
31	42-317	Light	1
	42-317-01	Replacement Bulb	
32	42-323	Light Mount	1
33	HSTP-14-20-100	Truss Head Screw $\frac{1}{4}$ - 20 x 1	2
	HNFL-14-20	Flange Whiz Lock Nut $\frac{1}{4}$ - 20	2
34	HNTL-58-11	Lock Nut $\frac{5}{8}$ - 11	2
35	HMB-58-14	Machine Bushing $\frac{5}{8} \times 14GA$	7
36	18-154	Yoke End	1
	HG-14-28-180	Grease Fitting $\frac{1}{4}$ - 28 x 180°	1
37	75-714	Hydraulic Cylinder	1
38	HB-58-11-200	Bolt $\frac{5}{8}$ - 11 x 2	2
39	18-168	$\frac{3}{8}$ Straight Thread Elbow	2
40	18-202	Elbow	1



LINKAGE DRAWING

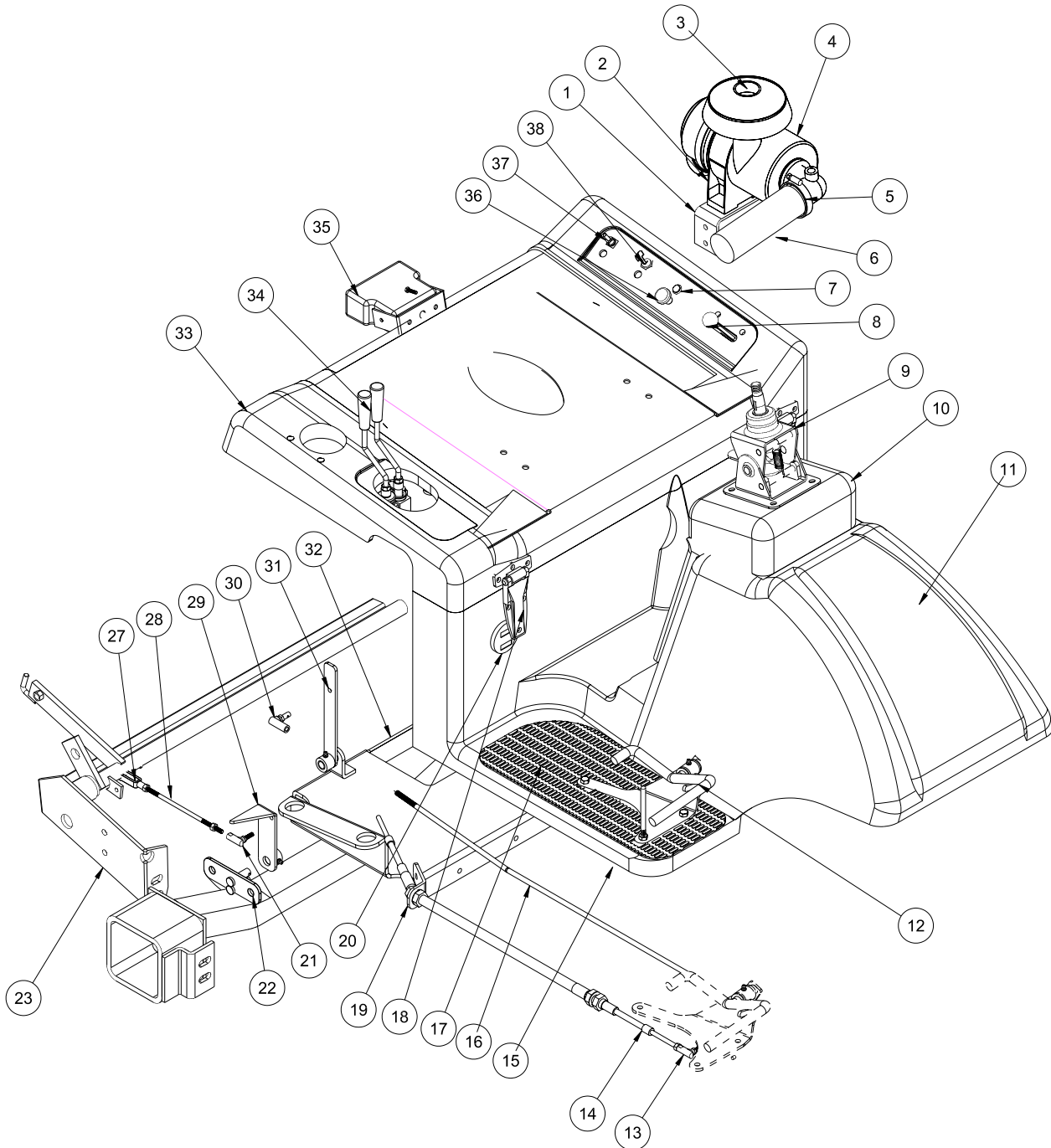

Parts

LINKAGE PARTSLIST

REF#	PART#	DESCRIPTION	QUANTITY
1	42-769	Oil Tank Bracket	1
	HB-516-18-100	Bolt $5/16$ - 18 x 1	2
	HNFL-516-18	Flange Whiz Lock Nut $5/16$ - 18	2
2	42-076-01	Band	1
3	42-076-02	Hat	1
4	42-076	Air Cleaner	1
	42-076-03	Replacement Filter	
	13-603	Air Cleaner Base (comes with engine)	1
5	18-123	Hose Clamp	2
6	8959-26	Flex Hose x 26"	1
	27-113	Air Cleaner Hose Elbow	1
	42-776	Air Tube	1
7	50-359	Warning Light	1
8	42-789	Throttle Cable	1
	42-766	Throttle Bracket	1
	HSTP-14-20-075	Phillips Truss Head Screw $1/4$ - 20 x $3/4$	2
	HNFL-14-20	Flange Whiz Lock Nut $1/4$ - 20	2
9	76-362	Tilt Steering	1
	76-364	Boot Black (comes with 76-362)	1
10	42-782	Console (fiberglass)	1
11	42-471	Nose Cone (fiberglass)	1
12	42-790	Foot Pedal	1
	HG-14-28-180	Grease Fitting $1/4$ - 28 x 180° (comes with 42-790)	1
	76-299	Pedal Pad Long	1
	42-791	Pedal Pad Short	1
	HB-516-18-150	Bolt $5/16$ - 18 x $1 1/2$	2
	HW-516	Washer $5/16$	2
	HNFL-516-18	Flange Whiz Lock Nut $5/16$ - 18	2
13	18-115	Ball Joint $1/4$ - 28	1
	HN-14-28	Nut $1/4$ - 28	2
	HWL-14	Lockwasher $1/4$	1
14	13-648	Cable	1
15	42-780	Floorboard (fiberglass)	1
16	43-023	Long Rod	1
17	42-767	Right Floor Mat	1
	42-768	Left Floor Mat	1
18	27-055	Hinge	2
	HSMFCS-10-32-100	Machine Screw #10 - 32 x 1	6
	HSM-10-32-063	Machine Screw #10 - 32 x $5/8$	4
	HNFL-10-32	Flange Whiz Lock Nut #10 - 32	10
19	42-323	Cable Bracket	1
20	12-017	Hour Meter	1
21	18-386	Spring Lock Ball Joint $1/4$ - 28	1
	HN-14-28	Nut $1/4$ - 28	2
	HWL-14	Lockwasher $1/4$	1
22	43-119	Speed Boss Pivot	1
23	42-024	Rake Lift	1

(Continued on next page)



LINKAGE DRAWING

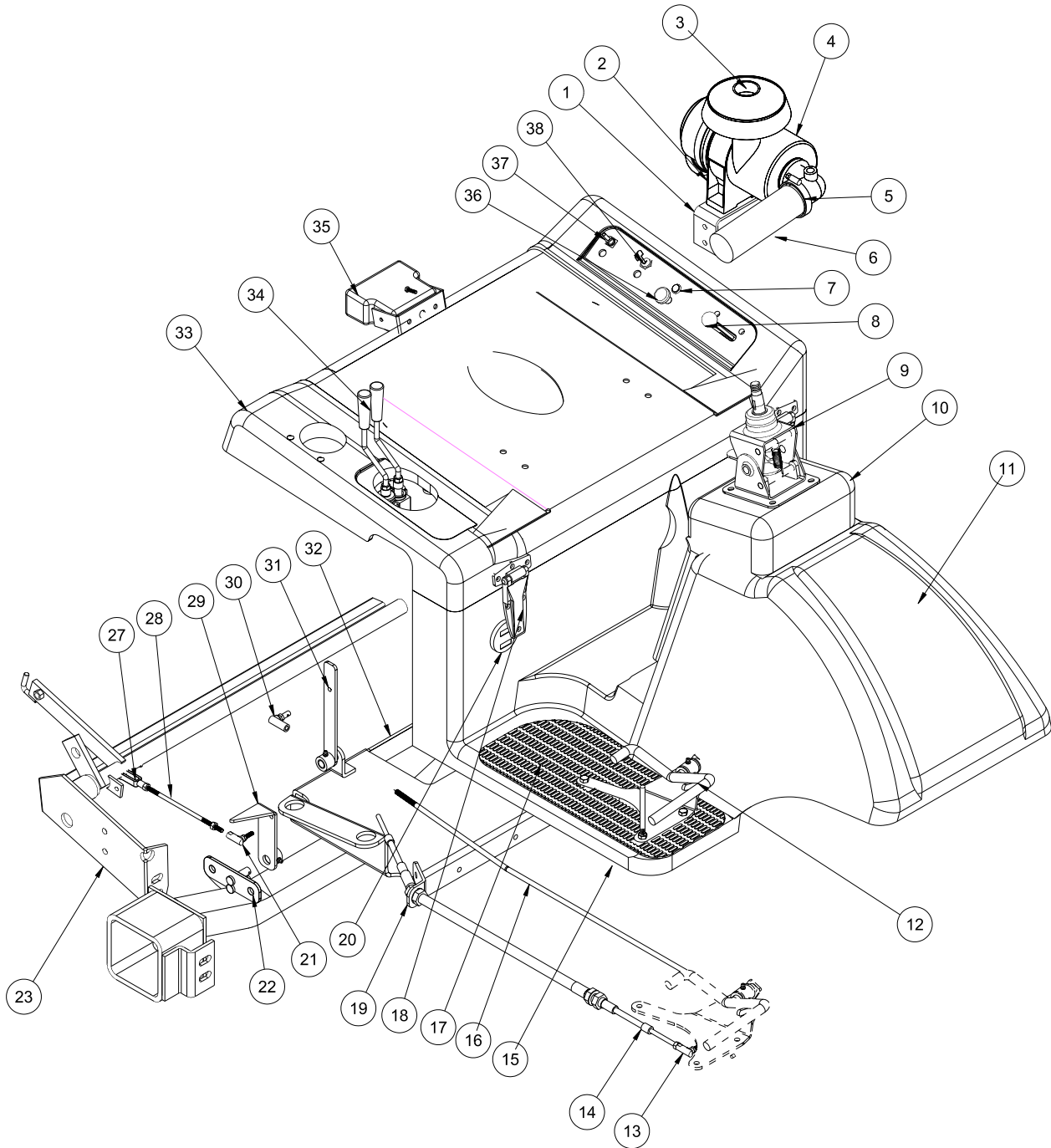

Parts

LINKAGE PARTSLIST

REF#	PART#	DESCRIPTION	QUANTITY
27	11-103	Linkage Yoke	1
	HN-14-28	Nut 1/4 -28	2
	HWL-14	Lockwasher 1/4	1
28	43-039	Short Rod	1
29	43-038	Speed Boss Bracket	1
30	21-462	Ball Joint 5/16 - 24	2
31	43-051	Speed Boss Arm	1
32	43-055	Engine Plate	1
33	42-779	Seat Panel	1
34	78-418	Levers	2
	42-765	Decal, Lift Controls	1
35	42-317	Light	1
	42-317-01	Replacement Bulb	1
	HSTP-14-20-100	Truss Head Screw 1/4 - 20 x 1	2
	HNFL-14-20	Flange Whiz Lock Nut 1/4 - 20	2
36	42-783	Choke	1
37	12-003	Light Toggle Switch	1
	15-472	Switch Boot	1
38	13-488	Key Switch (B&S 692318)	1
	76-310	Key Set	1

GAS TANK DRAWING

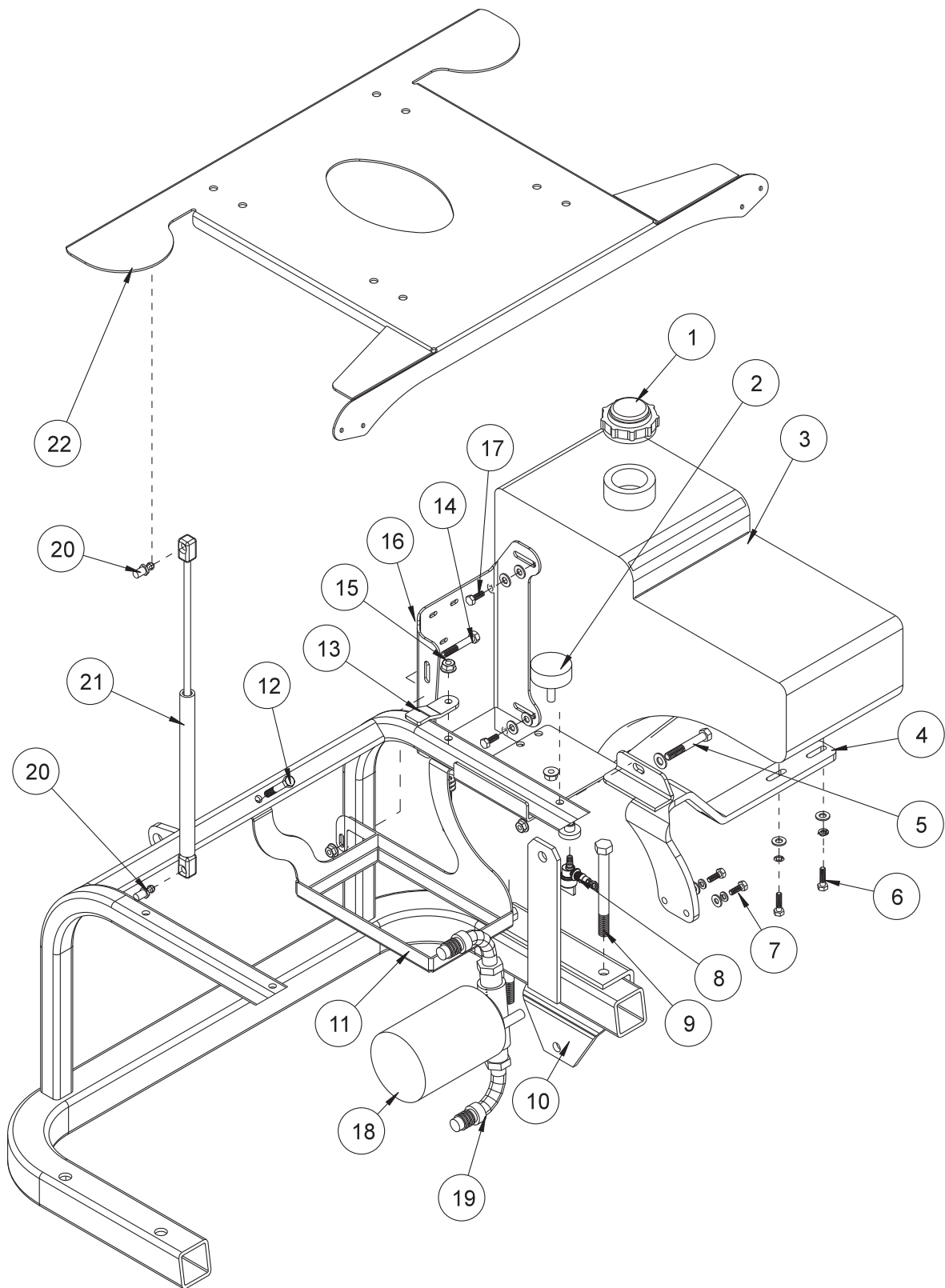

Parts

GAS TANK PARTSLIST

REF#	PART#	DESCRIPTION	QUANTITY
1	15-492	Cap	1
2	50-081	Rubber Bumper	1
	HNFL-38-16	Flange Whiz Lock Nut $\frac{3}{8}$ - 16	1
3	42-006	Gas Tank	1
4	42-770	Right Tank Support	1
5	HB-38-16-250	Bolt $\frac{3}{8}$ - 16 x $2\frac{1}{2}$	1
	HW-38	Washer $\frac{3}{8}$	2
	HNFL-38-16	Flange Whiz Lock Nut $\frac{3}{8}$ - 16	1
6	HB-14-20-100	Bolt $\frac{1}{4}$ - 20 x 1	2
	HW-14	Washer $\frac{1}{4}$	2
	HW-516	Washer $\frac{5}{16}$	2
	HWL-14	Lock Washer $\frac{1}{4}$	2
7	HB-14-20-075	Bolt $\frac{1}{4}$ - 20 x $\frac{3}{4}$	2
	HWL-14	Lockwasher $\frac{1}{4}$	2
	HW-14	Washer $\frac{1}{4}$	2
8	26-055	Fuel Shut Off (comes with 42-006)	1
	26-054	Rubber Grommet (comes with 42-006)	1
	8800-41	Fuel Hose	1
	18-186	Hose Clamp	2
9	HB-12-13-500	Bolt $\frac{1}{2}$ - 13 x 5	2
	HNFL-12-13	Flange Whiz Lock Nut $\frac{1}{2}$ - 13	2
10	42-015	Attachment Mount	1
11	42-273	Battery Box	1
12	HB-516-18-200	Bolt $\frac{5}{16}$ - 18 x 1	1
	HNFL-516-18	Flange Whiz Lock Nut $\frac{5}{16}$ - 18	1
13	42-248	Battery Hold-down	1
	15-020	Grip	1
14	HB-516-18-225	Bolt $\frac{5}{16}$ - 18 x $2\frac{1}{4}$	2
	HNFL-516-18	Flange Whiz Lock Nut $\frac{5}{16}$ - 18	2
15	HB-516-18-225	Bolt $\frac{5}{16}$ - 18 x $2\frac{1}{4}$	1
	HW-516	Washer $\frac{5}{16}$	3
	HNFL-516-18	Flange Whiz Lock Nut $\frac{5}{16}$ - 18	1
16	42-773	Gas Tank Bracket	1
17	HB-14-20-075	Bolt $\frac{1}{4}$ - 20 x $\frac{3}{4}$	2
	HW-14	Washer $\frac{1}{4}$	2
	HWL-14	Lock Washer $\frac{1}{4}$	2
18	23-006	Oil Filter	1
	23-031	Replacement Filter	1
19	34-123	Elbow	1
20	26-034	Ball Stud	2
21	13-569	Gas Shock	1
22	42-772	Seat Panel	1

OIL TANK DRAWING

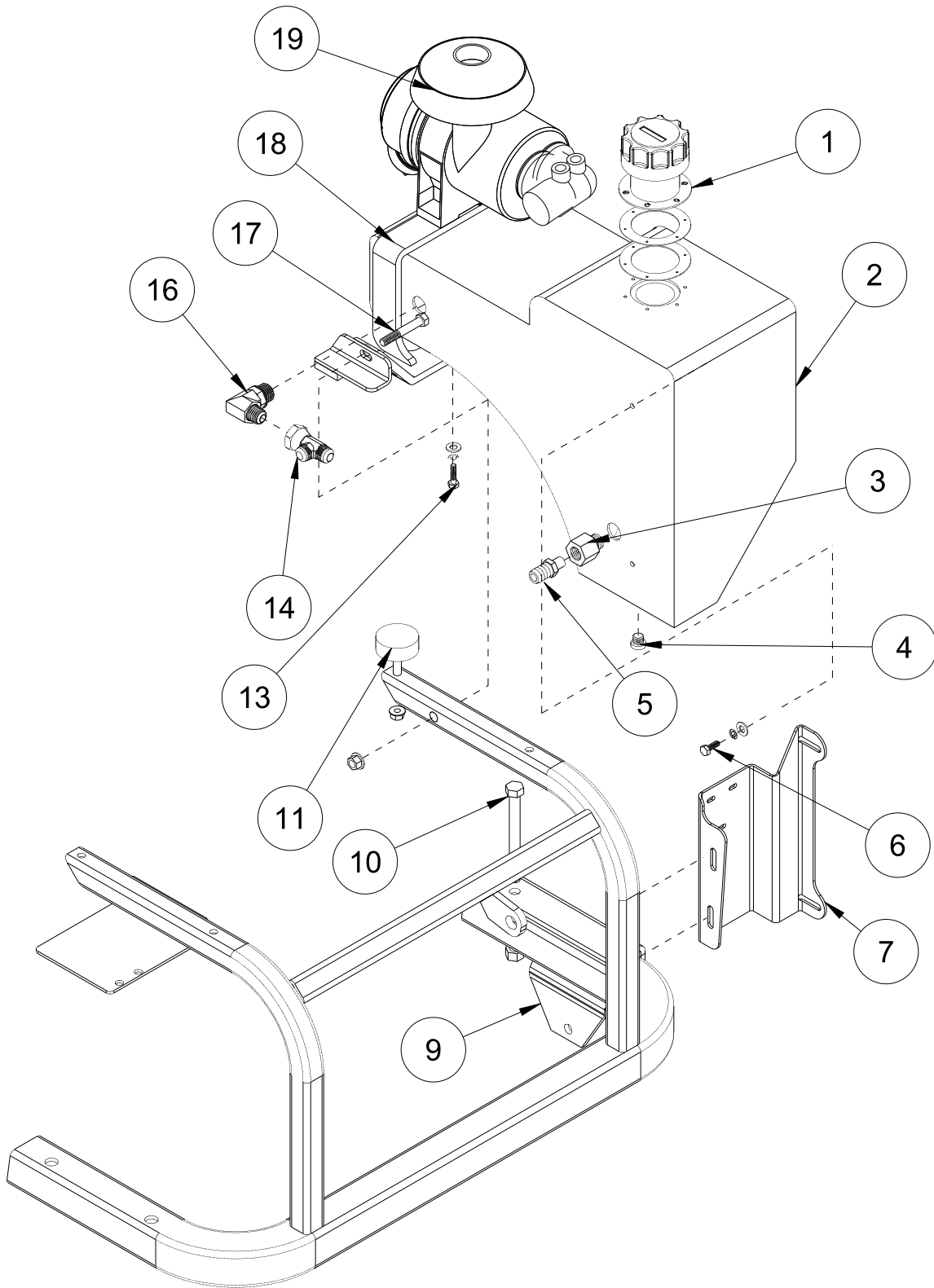

Parts

OIL TANK PARTSLIST

REF#	PART#	DESCRIPTION	QUANTITY
1	13-586	Filler Breather	1
	13-586-01	Cap Gasket	1
	13-586-02	Bottom Gasket	2
	HSM-8-32-050	Machine Screw #8 - 32 x 1/2	6
	HWS-8	Star Washer #8	6
2	42-005	Oil Tank	1
3	18-240	Adapter	1
4	23-126	#6 Plug	1
5	18-133	Barb Fitting	1
6	HB-14-20-075	Bolt 1/4 - 20 x 3/4	2
	HW-14	Washer 1/4	2
	HWL-14	Lock Washer 1/4	2
7	42-774	Oil Tank Bracket	1
	HB-516-18-225	Bolt 5/16 - 18 x 2 1/4	2
	HNFL-516-18	Flange Whiz Lock Nut 5/16 - 18	2
9	42-015	Attachment Mount	1
10	HB-12-13-500	Bolt 1/2 - 13 x 5	2
	HNFL-12-13	Flange Whiz Lock Nut 1/2 - 13	2
11	50-081	Rubber Bumper	1
	HNFL-38-16	Flange Whiz Lock Nut 3/8 - 16	1
13	HB-38-16-150	Bolt 3/8 - 16 x 1 1/2	1
	HW-38	Washer 3/8	1
	HNFL-38-16	Flange Whiz Lock Nut 3/8 - 16	1
14	18-337	Tee	1
16	23-189	90° Elbow	1
17	HB-38-16-250	Bolt 3/8 - 16 x 2 1/2	1
	HW-38	Washer 3/8	1
	HNFL-38-16	Flange Whiz Lock Nut 3/8 - 16	1
18	42-769	Left Tank Bracket	1
19	42-076	Remote Air Cleaner	1

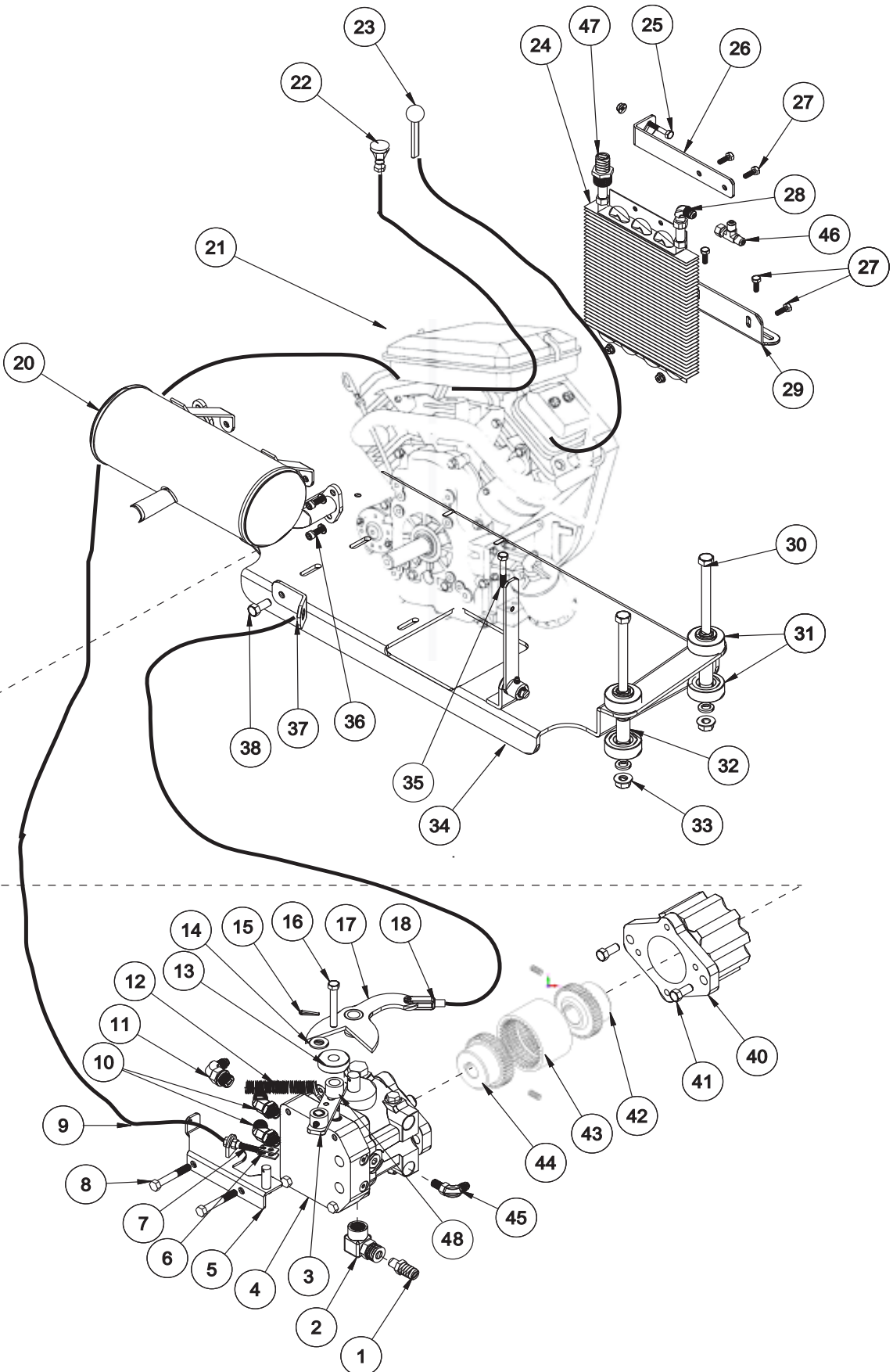

Parts

ENGINE PARTS LIST

REF #	PART #	DESCRIPTION	QUANTITY
1	18-133	Barb Fitting	1
2	23-127	Elbow	1
3	43-056	Idler Arm	1
4	43-127	Variable Pump	1
	HSSH-12-13-175	Socket Head Screw $\frac{1}{2}$ - 13 x $1\frac{1}{4}$	2
	HWL-12	Lock Washer $\frac{1}{2}$	2
	HHP-18	Bridge Pin $\frac{1}{4}$	1
5	43-040	Shift Arm Base	1
6	17-153	Clevis	1
	HCP-14-075	Clevis Pin $\frac{1}{4}$ x $\frac{3}{4}$	1
	HP-332-075	Cotter Pin $\frac{3}{32}$ x $\frac{3}{4}$	1
7	17-155	Retainer	1
	HN-516-24	Nut $\frac{5}{16}$ - 24	2
8		Bolts on Pump	4
9	17-151	Cable	1
	17-152	Conduit	1
10	18-266	45° Elbow	2
11	18-185	Elbow	1
12	13-297	Spring	1
13	14-266	Ball Bearing	1
14	HMB-12-14	Machine Bushing $\frac{1}{2}$ -14GA	1
15	HP-18-100	Cotter Pin $\frac{1}{8}$ x 1	1
16	HB-38-16-275	Bolt $\frac{3}{8}$ - 16 x $2\frac{3}{4}$	1
	HW-38	Washer $\frac{3}{8}$	1
	HWL-38	Lock washer $\frac{3}{8}$	1
	HNTL-38-16	Lock Nut $\frac{3}{8}$ - 16	1
17	43-054	Shift Arm	1
	HRP-14-100	Roll Pin $\frac{1}{4}$ -100	1
18	11-103	Linkage Yoke	2
	13-648	Cable	1
20	42-600	Muffler	1
	42-601	Muffler Gear	1
21	43-024	Engine, Briggs & Stratton 18HP	1
	21-161	Wire Block	4
22	42-783	Choke Cable	1
23	42-789	Throttle Cable	1
24	42-265	Aluminum Oil Cooler	1
25	HB-14-20-150	Bolt $\frac{1}{4}$ - 20 x $1\frac{1}{2}$	1
	HNFL-14-20	Flange Whiz Lock nut $\frac{1}{4}$ -20	1
26	42-771	Top Cooling Bracket	1
27	HB-14-20-075	Bolt $\frac{1}{4}$ - 20 x $\frac{3}{4}$	1
	HNFL-14-20	Flange Whiz Lock Nut $\frac{1}{4}\frac{1}{4}$ - 20	1
28	18-202	Elbow	1
29	43-037	Bottom Cooler Bracket	1
30	HB-12-13-500	Bolt $\frac{1}{2}$ - 13 x 5	4
31	60-107	Rubber Bushing	8
32	60-168	Spacer	4
33	HNFL-12-13	Flange Whiz Lock Nut $\frac{1}{2}$ - 13	4
34	43-055	Engine Plate	1
35	HB-516-18-225	Bolt $\frac{5}{16}$ - 18 x $2\frac{1}{4}$	4
	HNFL-516-18	Flange Whiz Lock Nut $\frac{5}{16}$ - 18	4

(Continued on next page)

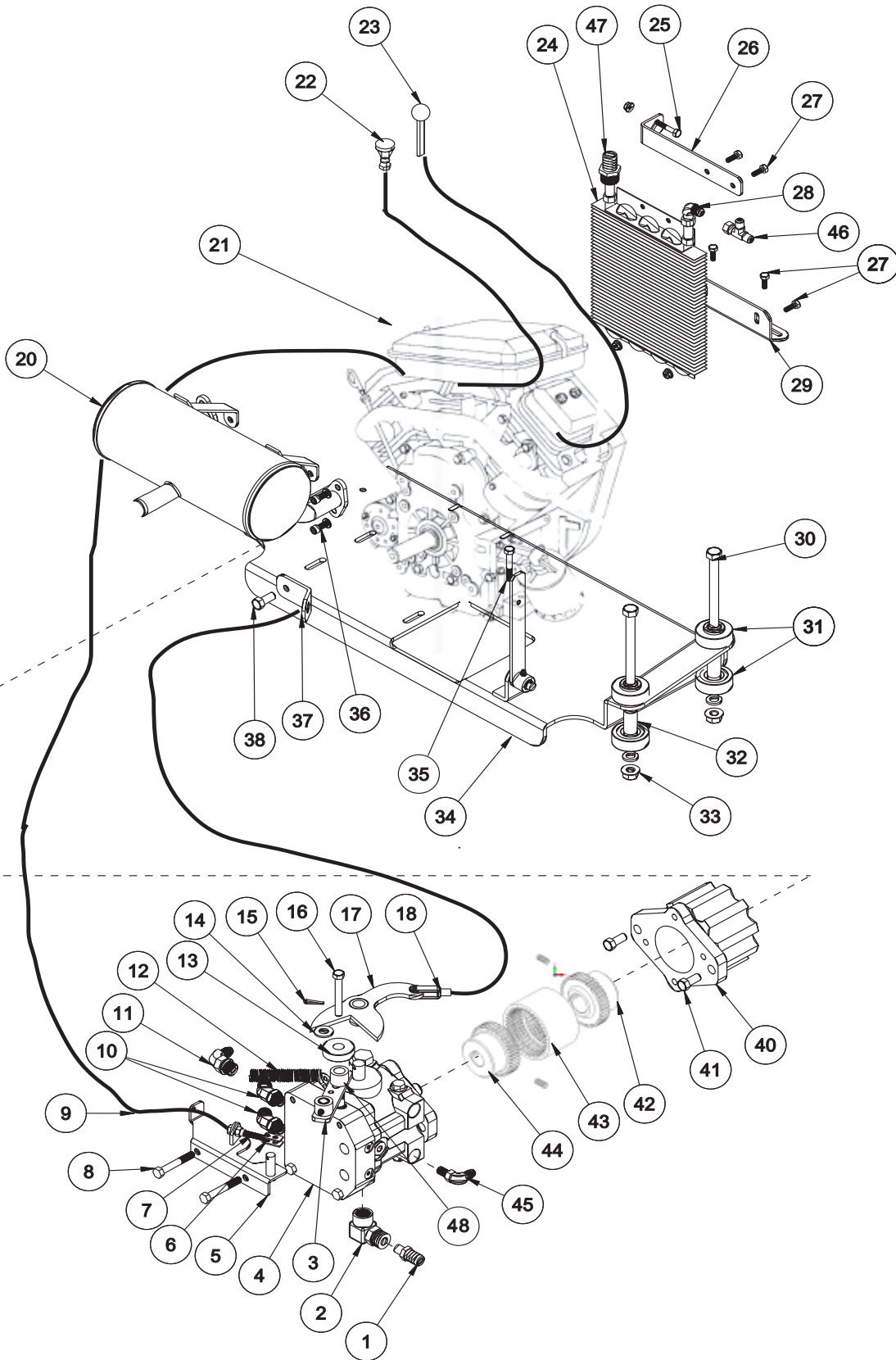

Parts

ENGINE PARTS LIST

REF #	PART #	DESCRIPTION	QUANTITY
36	HSSHSM-8-1.25-20	Socket Head Cap Screw M8 x 1.25	4
	HWLM-8	Metric Lock Washer M8	4
37	43-022	Cable Bracket	1
38		Bolt on Engine	
40	60-212	Adapter Pump Mount	1
	60-212-01	Cap Assembly	1
41	HB-716-14-125	Bolt $\frac{7}{16}$ - 14 - $1\frac{1}{4}$	2
	HWL-716	Lock Washer $\frac{7}{16}$	2
42	43-099	Coupler Half #4 1" Bore	1
	HSSHS-716-14-075	Socket Head Set Screw $\frac{7}{16}$ - 14 x $\frac{3}{4}$	1
	HSSHS-38-16-038	Socket Head Set Screw $\frac{3}{8}$ - 16 x $\frac{3}{8}$	1
	HKSQ-14-100	Machine Key $\frac{1}{4}$ x $\frac{1}{4}$ x 1	1
43	43-098	Coupler Insert #4	1
44	43-097	Coupler Half #4 $\frac{3}{4}$ " Bore	1
	HSSHS-716-14-075	Socket Head Set Screw $\frac{7}{16}$ - 14 x $\frac{3}{4}$	1
	HSSHS-385-16-038	Socket Head Set Screw $\frac{3}{8}$ - 16 x $\frac{3}{8}$	1
	HWK-316-075	Woodruff Key	1
45	18-168	Straight Thread Elbow $\frac{3}{8}$	1
46	18-190	Tee	1
47	18-249	Barb Fitting	1
48	76-298	Spacer	1

REAR AXLE DRAWING

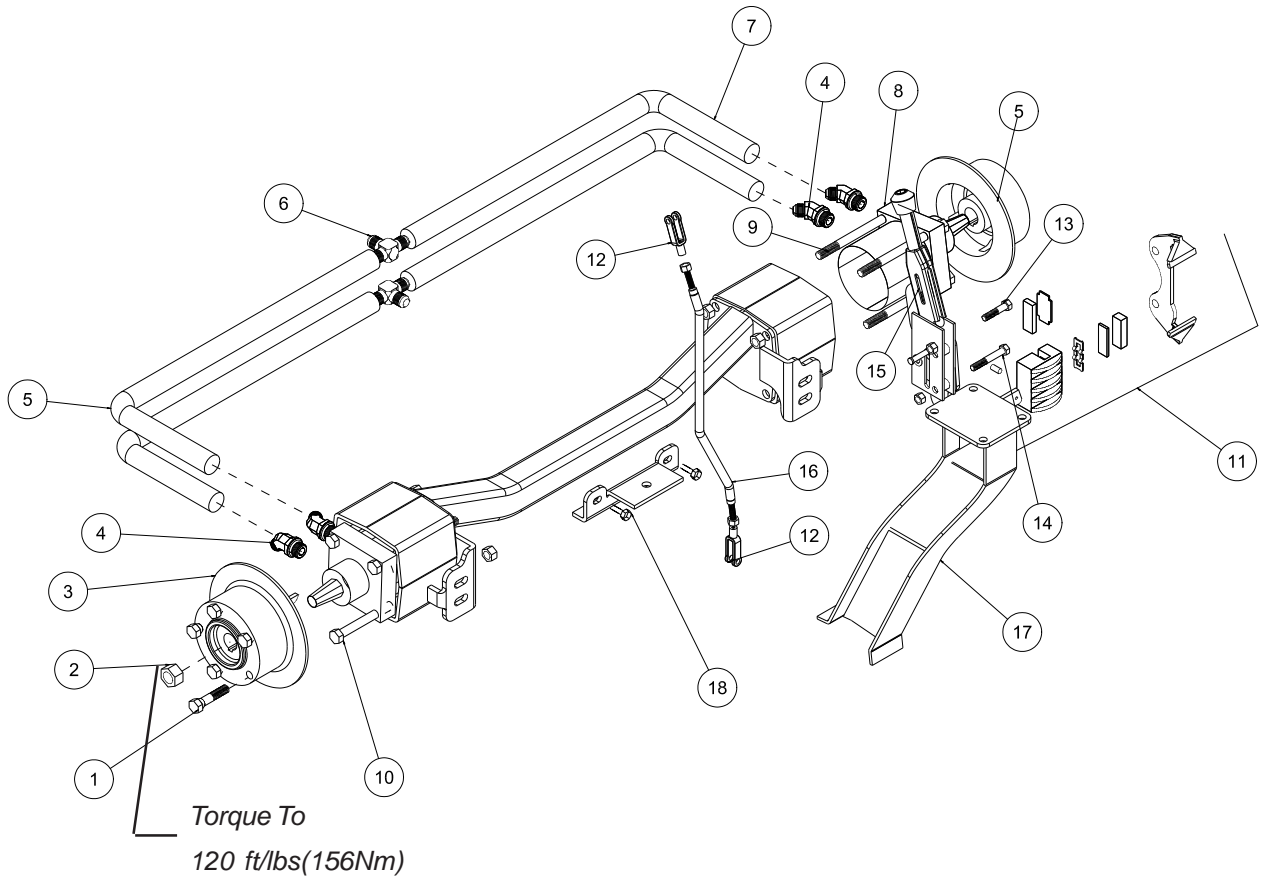

Parts

REAR AXLE PARTSLIST

REF#	PART#	DESCRIPTION	QUANTITY
1	60-268	Lug Bolt	10
2	14-265	Nut 1-20	2
3	76-239	Brake Disc	2
4	18-383	45° Adapters	4
5	43-095	Hydraulic Tube	2
6	18-170	Tee	2
7	43-094	Hydraulic Tube	2
8	13-615	Wheel Motor	2
	HWK-14-100	Woodruff Key 1/4 x 1	2
9	HB-12-13-750	Bolt 1/2 -13 x 7 1/2	2
	HNTL-12-13	Lock Nut 1/2 - 13	2
10	HB-12-13-700	Bolt 1/2 -13 x 7	6
	HNTL-12-13	Lock Nut 1/2 - 13	6
11	42-496	Right Caliper CW	1
12	11-100	Linkage Yoke	2
	HCP-516-100	Clevis Pin 5/16 x 1	2
	HP-18-100	Cotter Pin 1/8 x 1	2
13	HB-516-18-175	Bolt 5/16 - 18 x 1 3/4	1
	HNFL-516-18	Flange Whiz Lock Nut 5/16 - 18	1
14	HB-516-18-250	Bolt 5/16 - 18 x 2 1/2	1
	HNFL-516-18	Flange Whiz Lock Nut 5/16 - 18	1
15	60-106	Brake Lever	1
16	42-804	Brake Rod	1
	HN-516-24	Nut 5/16 - 24	2
17	42-596	Main Frame	1
18	43-142	Hitch	1
	HB-38-24-100	Bolt 3/8 - 24 x 1	2
	34-101-01	Brake Pads (only)	
	34-101-02	Brake Pad Kit (pads with steel backing plate)	

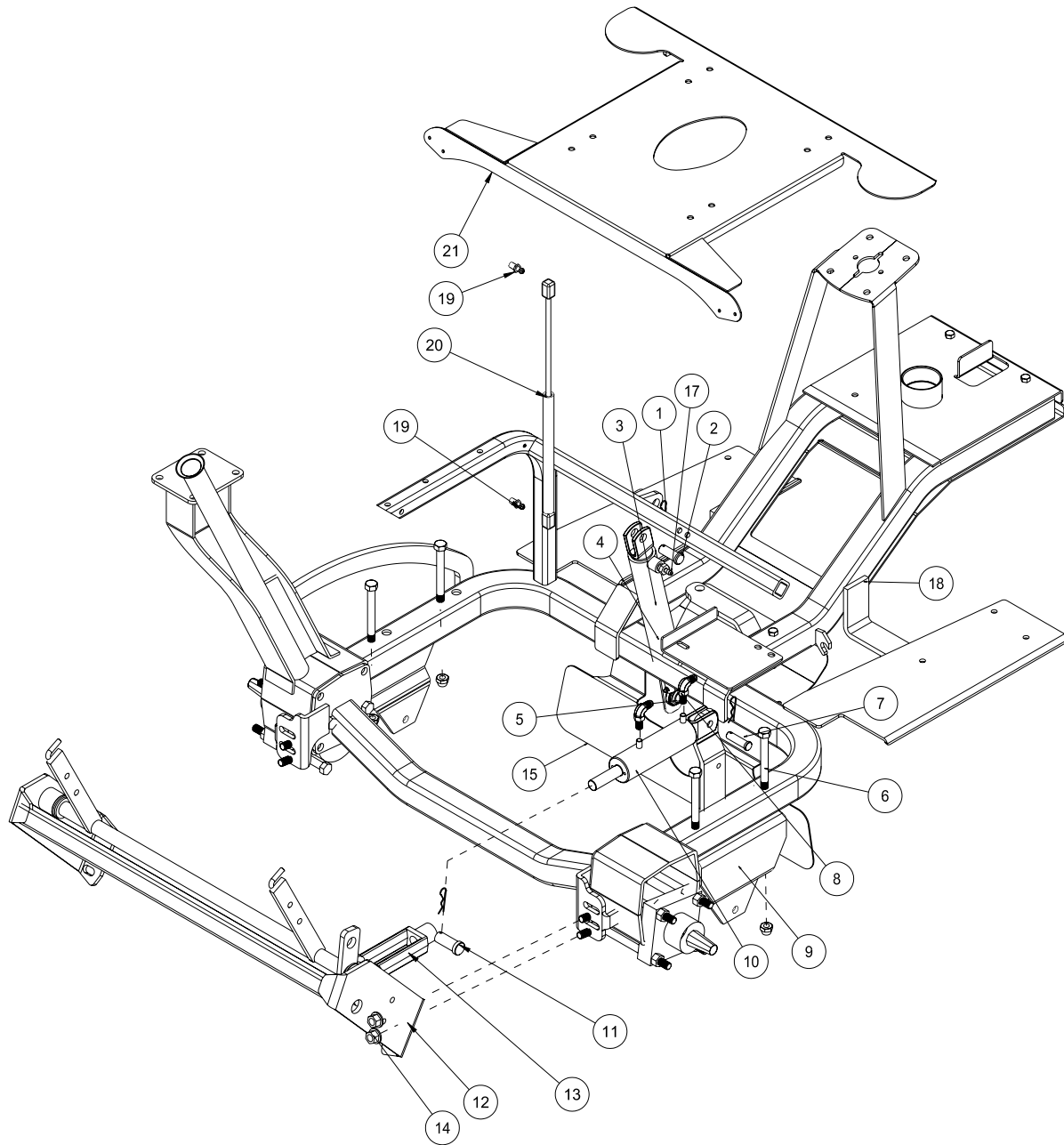

RAKE LIFT PARTS LIST

REF#	PART#	DESCRIPTION	QUANTITY
1	HHP-18	Bridge Pin $\frac{1}{8}$	3
2	HCP-58-175	Clevis Pin $\frac{5}{8}$ - $1\frac{3}{4}$	1
3	10-135	Hydraulic Cylinder	1
	HNJ-58-18	Jam Nut $\frac{5}{8}$ - 18	1
4	42-217	Cylinder Mount	1
5	18-154	Rod End	1
	HG-14-28-180	Grease Fitting $\frac{1}{4}$ - 28 x 180°	1
6	HB-12-13-500	Bolt $\frac{1}{2}$ - 13 x 5	4
	HNFL-12-13	Flange Whiz Lock Nut $\frac{1}{2}$ - 13	4
7	HCP-12-150	Clevis Pin $\frac{1}{2}$ - $1\frac{1}{2}$	1
8	18-168	90° Elbow	2
9	42-015	Attachment Mount	2
10	13-357	Hydraulic Cylinder	1
	HNJ-34-16	Jam Nut $\frac{3}{4}$ - 16	1
11	42-040	Yoke (Bottom Hook-up)	1
12	42-024	Rake Lift	1
13	HCP-34-200	Clevis Pin $\frac{3}{4}$ x 2	1
14	HNFL-12-13	Flange Whiz Lock Nut $\frac{1}{2}$ - 13	4
	HW-12	Washer $\frac{1}{2}$	4
15	42-590	Mud Guard	1
17	18-188	45° Elbow	2
18	43-120	Main Frame	1
19	26-034	Ball Stud	2
20	13-569	Gas Shock	1
21	42-772	Seat Mount	1

13-729 2-BANK HYDRAULIC VALVE DRAWING

Parts

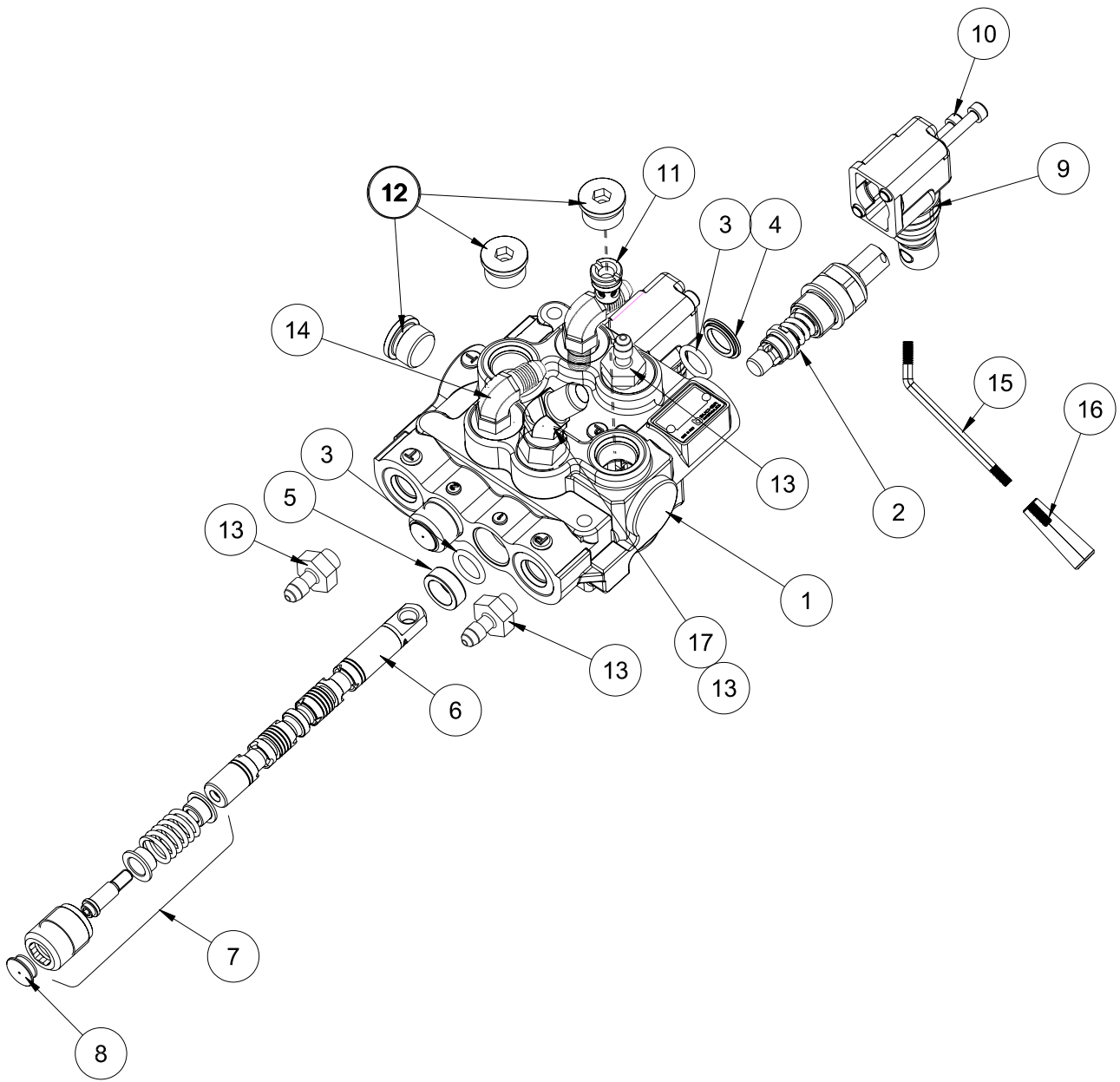

13-729 2-BANK HYDRAULIC VALVE PARTSLIST

REF #	PART #	DESCRIPTION	QUANTITY
1*	78-415-01	Body (complete with spacer and check valve)	1
2*	78-415-02	Spool HDM10	1
3*	78-415-03	O-Ring Seal	4
4*	78-415-04	Flanged Washer HDM10	2
5*	78-415-05	Spacer	2
6*	78-415-06	A Type Spool HDS11	2
7*	78-415-11	Positioner	2
8*	78-415-08	Plug	2
9*	78-415-09	Lever Group HDS11	2
10*	78-415-10	Metric Socket Screw M5 x .8 x 45	4
11*	78-415-12	Check Valve Assembly HDM12	1
12*	78-415-13	$\frac{3}{4}$ - 16 SAE 8 Screw Plug	3
13	18-169	Adapter $\frac{1}{4}$ - $\frac{3}{8}$ SAE	3
14	18-168	Elbow $\frac{3}{8}$ Straight Thread	3
15	78-418	Bent Handle	2
16	8-552-01	Tapered Knob	2
17	18-214	Elbow 45°	1
* 	13-729	2 – Bank Hydraulic Valve (includes all * items)	

76-238 FRONT WHEEL MOTOR DRAWING (14.5 CI)

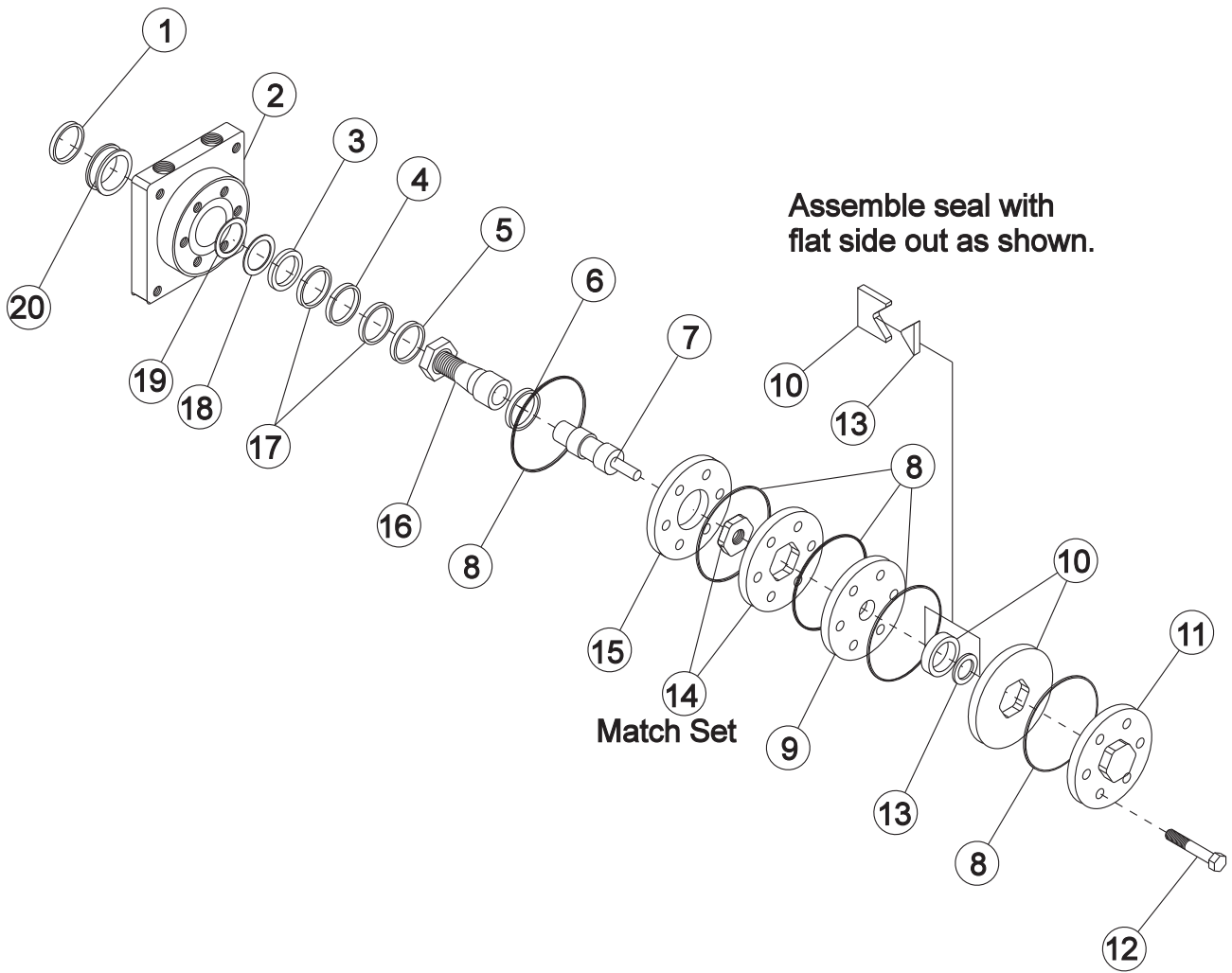

76-238 FRONT WHEEL MOTOR PARTS LIST (14.5 CI)

REF#	PART#	DESCRIPTION	QUANTITY
1*		Water & Dirt Seal	1
2†	13-615-05	Service Housing Assembly	1
3*		Inner Seal	1
4†	13-032-27	Thrust Bearing	1
5†	13-032-28	Inner Bearing	1
6	13-032-29	Thrust Bearing	1
7	76-238-03	Drive Link	1
8*		Ring Seal	5
9	13-032-31	Manifold	1
10	13-032-32	Commutator Assembly (matched set)	1
11	13-032-33	End Cover	1
12	76-238-01	Bolt	7
13*		Commutator Seal (matches with #10)	1
14	76-238-02	Rotor Set (matched set)	1
15	13-032-35	Plate Wear	1
16	13-615-04	Coupling Shaft	1
	HWK-516-100	Woodruff Key ⁵ / ₁₆ X 1	1
	14-265	Nut 1 - 20	1
17†	13-032-37	Thrust Washer	2
18*		Backup Washer	1
19*		Backup Washer	1
20†	13-032-38	Outer Bearing	1
*	14-080	Seal Kit	1
†	Included in 13-615-05 Service Housing Assembly		

13-615 REAR WHEEL MOTOR (7.5 C.I.) DRAWING

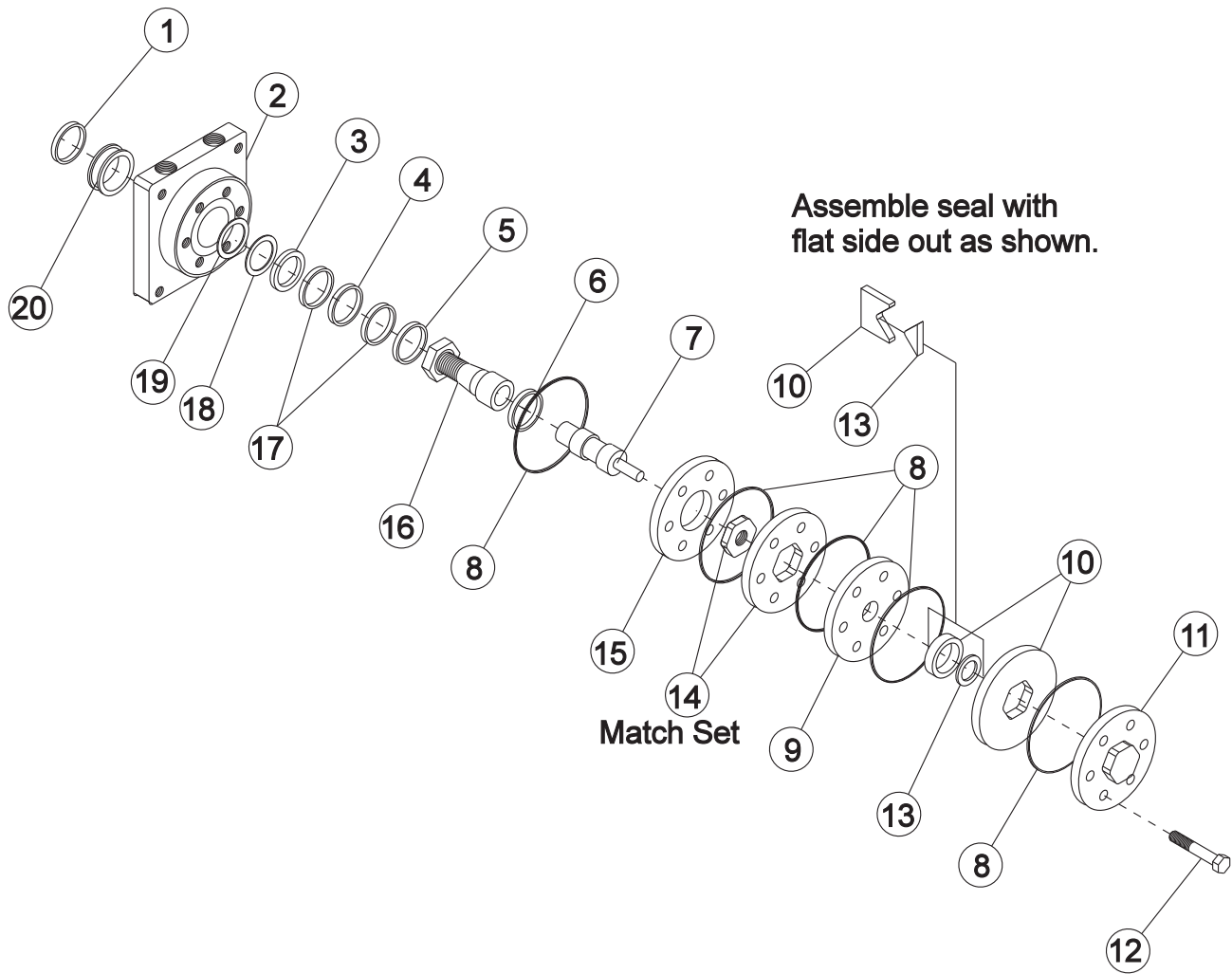

13-615 REAR WHEEL MOTOR (7.5 C.I.) PARTSLIST

REF#	PART#	DESCRIPTION	QUANTITY
1*		Water & Dirt Seal	1
2	13-615-05	Service Housing Assembly (Includes Ref 4, 5, 17(2 req'd) and 20)	1
3*		Inner Seal	1
4	13-032-27	Thrust Bearing	1
5	13-032-28	Inner Bearing	1
6	13-032-29	Thrust Bearing	1
7	13-615-03	Drive Link	1
8*		Ring Seal	5
9	13-032-31	Manifold	1
10	13-032-32	Commutator Assembly (matched set)	1
11	13-032-33	End Cover	1
12	13-615-01	Bolt	7
13*		Commutator Seal (matches with #10)	1
14	13-615-02	Rotor Set (matched set)	1
15	13-032-35	Plate Wear	1
16	13-615-04	Coupling Shaft	1
	HWK-516-100	Woodruff Key ⁵ / ₁₆ X 1	1
	14-265	Nut 1 - 20	1
17	13-032-37	Thrust Washer	2
18*		Backup Washer	1
19*		Backup Washer	1
20	13-032-38	Outer Bearing	1
*	14-080	Seal Kit	1

43-003 HYDRAULIC SAND PLOW DRAWING

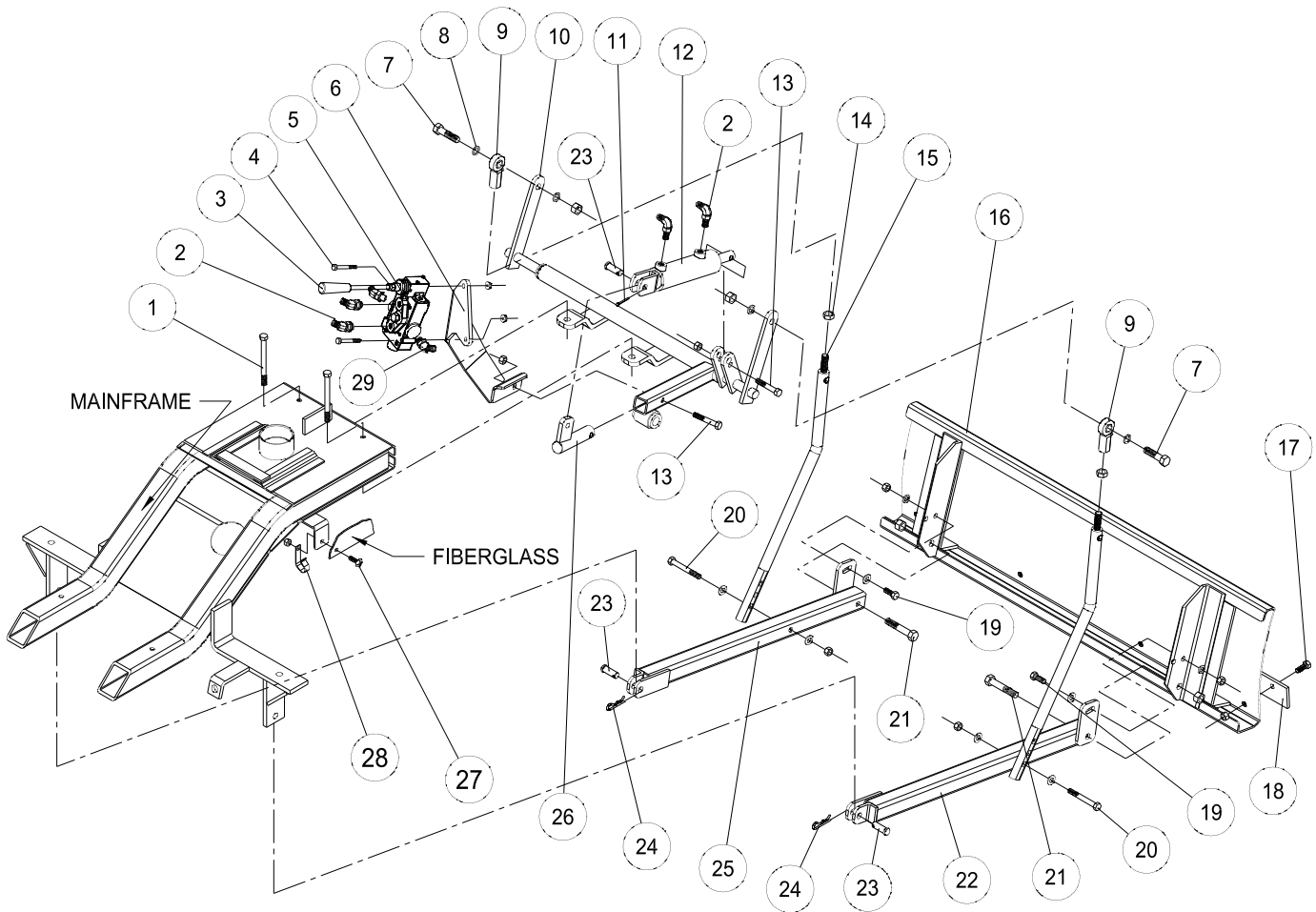

HYDRAULIC VALVE PLUMBING DRAWING

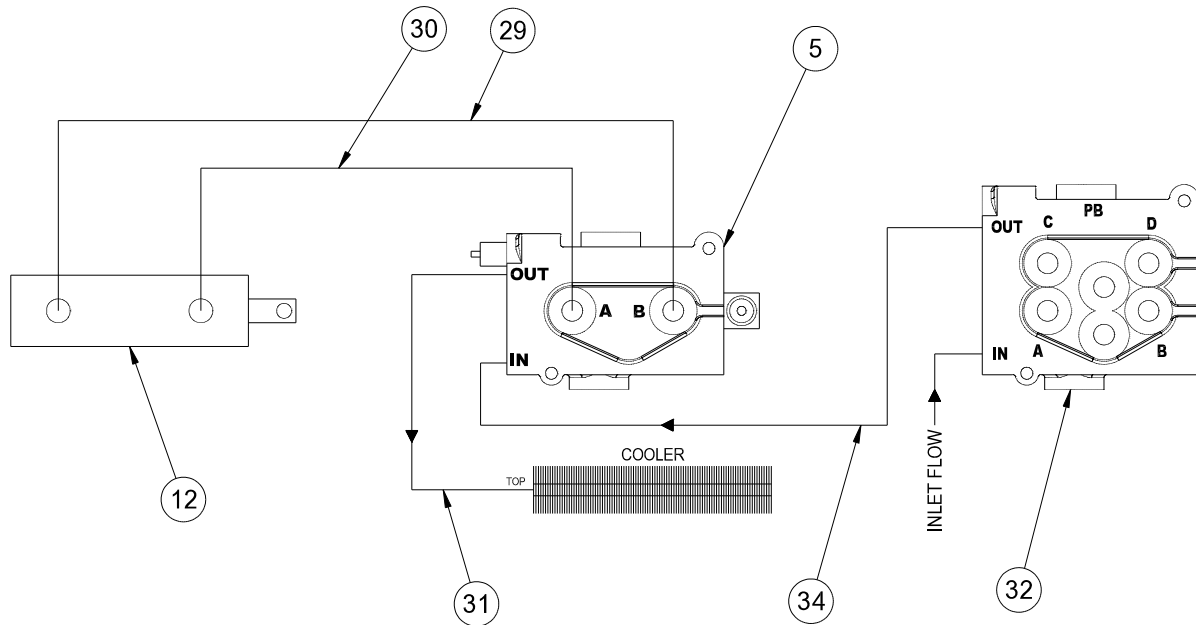

Accessories

43-003 HYDRAULIC SAND PLOW PARTS LIST

REF#	PART#	DESCRIPTION	QUANTITY
1	HB-38-16-350	Bolt, $\frac{3}{8}$ - 16 x $3\frac{1}{2}$ (Part of machine)	2
	HW-38	Washer, $\frac{3}{8}$	2
	HNTL-38-16	Lock Nut, $\frac{3}{8}$ - 16	2
2	18-188	45° Elbow	6
3	42-225	Straight Handle Kit	1
4	HB-14-20-200	Bolt, $\frac{1}{4}$ - 20x 2	2
	HNFL-14-20	Flange Whiz-Lock Nut, $\frac{1}{4}$ - 20	2
5	13-731	Single Bank Hydraulic Valve	1
6	43-050	Valve Mount	1
7	HB-12-13-200	Bolt, $\frac{1}{2}$ - 13 x 2	2
	HNTL-12-13	Lock Nut, $\frac{1}{2}$ - 13	2
8	HMB-12-14	Machine Bushing, $\frac{1}{2}$ x 14GA	4
9	80-006	Rod End	2
10	42-346	Lift Assembly	1
11	HP-18-100	Cotter Pin, $\frac{1}{8}$ x 1	1
12	13-292	Hydraulic Cylinder	1
13	HB-38-16-200	Bolt, $\frac{3}{8}$ - 16 x 2	2
	HNTL-38-16	Lock Nut, $\frac{3}{8}$ - 16	2
14	HNJ-12-20	Jam Nut, $\frac{1}{2}$ - 20	2
15	27-073	Lift Rod	2
16	27-017	Aluminum Sand Plow Blade	1
17	HB-38-16-100	Bolt, $\frac{3}{8}$ - 16 x 1	4
	HNFL-38-16	Flange Whiz Lock Nut, $\frac{3}{8}$ - 16	4
18	13-167	Wear Blade	1
19	HB-38-16-125	Bolt, $\frac{3}{8}$ - 16 x $1\frac{1}{4}$	2
	HW-38	Washer, $\frac{3}{8}$	2
	HWL-38	Lockwasher, $\frac{3}{8}$	2
	HN-38-16	Nut, $\frac{3}{8}$ - 16	2
20	HB-38-16-300	Bolt, $\frac{3}{8}$ - 16 x 3	2
	HW-38	Washer, $\frac{3}{8}$	4
	HNTL-38-16	Lock Nut, $\frac{3}{8}$ - 16	2
21	HB-12-13-300	Bolt, $\frac{1}{2}$ - 13 x 3	2
	HNTL-12-13	Lock Nut, $\frac{1}{2}$ - 13	2
22	27-050	Right Pusher Bar	1
23	HCP-12-150	Clevis Pin, $\frac{1}{2}$ x $1\frac{1}{2}$	3
24	HHP-18	Bridge Pin, $\frac{1}{8}$	2
25	27-049	Left Pusher Bar	1
26	42-096	Cylinder Lift	1
27	HSTP-516-18-100	Machine Screw, $\frac{5}{16}$ - 18 x 1 (on machine)	
28	HLC-A-58	Loom Clamp	1
29	18-168	Elbow 90°	2
30	43-048	Hose, 20"	1
31	43-047	Hose, 57 $\frac{1}{2}$ "	1
32		Valve (on machine)	1
33	43-049	Hose, 18"	1
34	43-156	Hose, 75"	1

43-003 HYDRAULIC SAND FLOW DRAWING

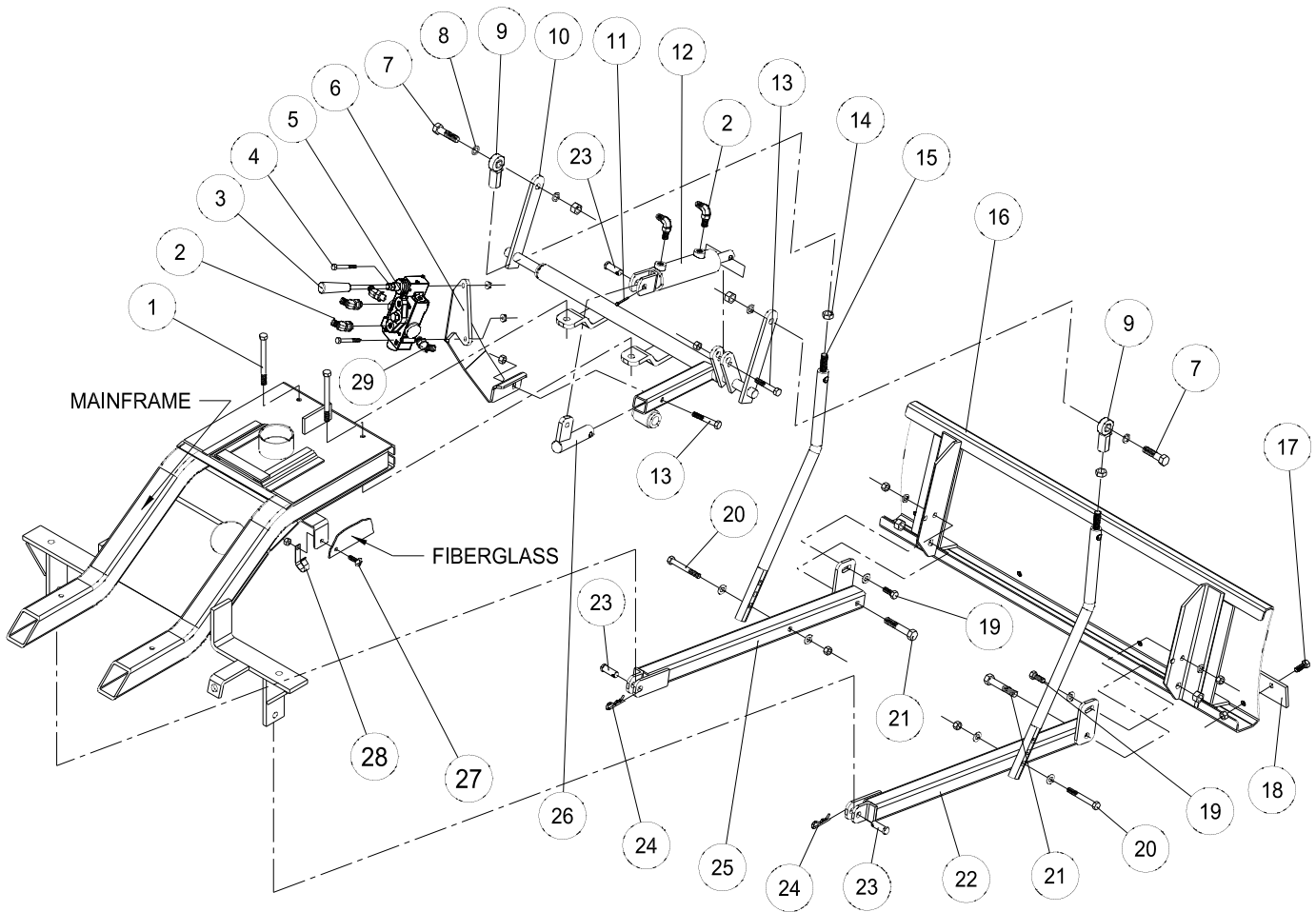

HYDRAULIC VALVE PLUMBING DRAWING

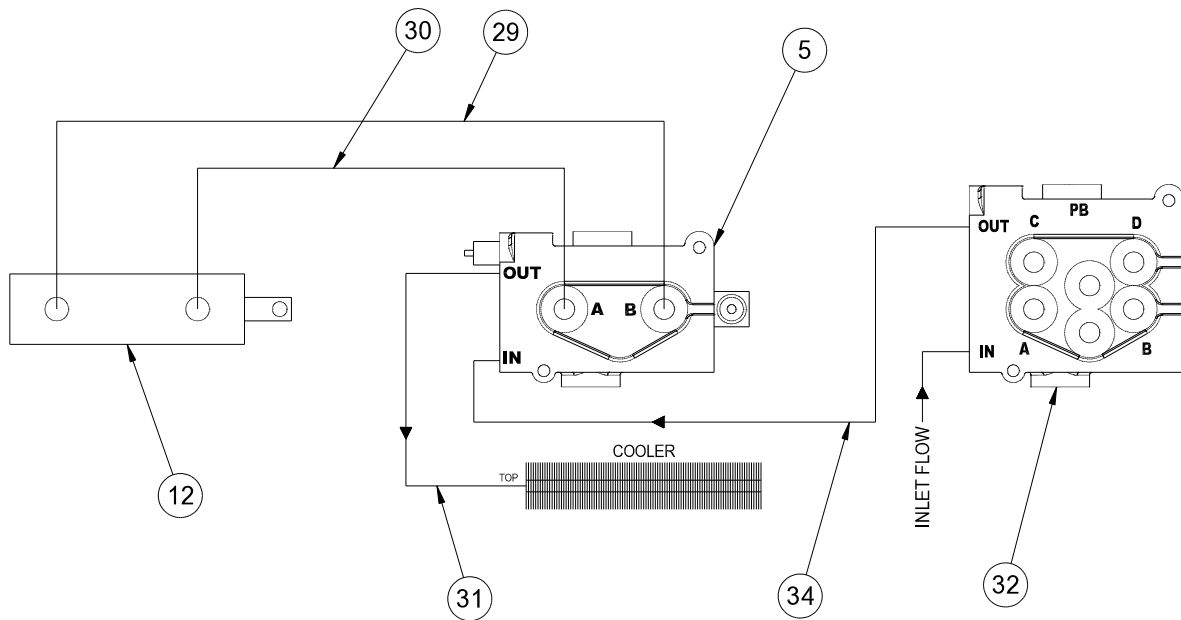

Accessories

43-003 HYDRAULIC SAND PLOW INSTRUCTIONS

1. Assemble Pusher Bars (Ref # 22 and 25) to Plow Blade (Ref # 16) using one $\frac{3}{8}$ -16 x 1 Bolt (Ref # 19) and one $\frac{3}{8}$ -16 x 3 Bolt (Ref #21) per Pusher Bar. There are 2 holes to bolt (Ref # 19) hardware in. Using hole closest to the blade will result in a shallow cut, whereas using the hole furthest from the blade will result in a deeper cut. The slot on the pusher bar is for a more fine tuned adjustment.
2. Assemble the Lift Assembly (Ref # 10) to the Main Frame using the two studs that are under the frame and below the front of the console.
3. Place Cylinder Lift (Ref # 26) into the tube on Lift Assembly (Ref # 10) with the tab pointing up hold with a $\frac{3}{8}$ -16 x 2 Bolt (Ref # 13), assemble the Valve Mount (Ref # 6) onto this bolt on the outside of the tube and secure both with one $\frac{3}{8}$ -16 Nut. Using a $\frac{3}{8}$ -16 x 2 Bolt mount the Hydraulic Cylinder (Ref # 12) to the Lift Assembly and secure with one $\frac{3}{8}$ -16 Nut. Connect the other end of the Hydraulic Cylinder to the Cylinder Lift using $\frac{1}{2}$ x 1 $\frac{1}{2}$ Clevis Pin (Ref # 23) and $\frac{1}{8}$ x 1 Cotter Pin (Ref #11).
4. Thread one $\frac{1}{2}$ - 20 Jam Nut (Ref # 14) onto each Lift Rod (Ref # 15) followed by the Rod Ends (Ref # 9). Adjust to equal lengths. Bolt Lift Rods to Lift Arms on Lift Assembly (Ref # 10) with Rod Ends to the outside. Bolt from outside with the $\frac{1}{2}$ " Machine Bushing (Ref # 8) between Rod End and Lift Arm and secure with $\frac{1}{2}$ -13 Lock Nut.
5. Slide the Plow/Pusher Bar Assembly under machine and connect to machine. Secure using $\frac{1}{2}$ x 1 $\frac{1}{2}$ Clevis Pins (Ref # 23) and $\frac{1}{8}$ " Bridge Pins (Ref # 24).
6. To connect Lift Rods (Ref # 15) to Pusher Bars start by lifting up the Plow Blade. Using one $\frac{3}{8}$ -16 x 3 Bolt (Ref # 20) and two $\frac{3}{8}$ " Washers assembly the Lift Rods to the Right (Ref #22) and Left (Ref # 25) Pusher Bars using the bottom hole in the Lift Rods as illustrated. Secure each with one $\frac{3}{8}$ -16 Lock Nut.
7. To fine tune the height of the blade off ground; turn the Rod Ends (Ref # 9) on the Lift Rods (Ref # 15). Turning the Rod Ends counter-clockwise will increase down pressure. Turning them clockwise will decrease down pressure.
8. Thread two of the 45° Elbow fittings (Ref # 2) into the Single Bank Valve (Ref # 5), one each in the **A** port, **B** port. Thread two of the 90° Elbow fittings (Ref # 29) into the Single Bank Valve **IN** port and **OUT** port. Thread the remaining two 45° (Ref # 2) Elbow fittings into the ports on the Hydraulic Cylinder (Ref # 12). Make sure the fittings on the Hydraulic Cylinder are pointing towards the machine.
9. Connect the 57 $\frac{1}{2}$ " Hose (Ref # 31) to the inlet on the Single Bank Hydraulic Valve (Ref #5). Connect the 75" Hose (Ref # 34) to the **OUT** port. Next connect the 18" Hose (Ref # 27) to the fitting in the **B** port and connect the 20" Hose (Ref # 28) to the fitting in the **A** port.
10. Mount the Single Bank Hydraulic Valve (Ref # 5) to the Valve Mount (Ref # 6) as illustrated using the two $\frac{1}{4}$ - 20 x 2 Bolts (Ref # 4). Secure with the two $\frac{1}{4}$ - 20 Flange Whiz-Lock Nuts. Connect the Straight Handle Kit (Ref # 3) to the Valve. Reference *Single Bank Hydraulic Valve Drawing* on page 6 for a detailed view of the Valve. *The Single Bank Valve is used in some other applications, therefore the handle housing may need to be reversed. Remove the two screws holding the housing assembly onto the valve body, turn it over and reinstall the screws. The handle must be pointing upward (reference drawing on page 44) when the valve is sitting on a table.*
11. Route the 18" Hose (Ref # 29) from the **B** port on the Single Bank Hydraulic Valve (Ref # 5) to the rear port on the Hydraulic Cylinder. Route the 20" Hose (Ref # 30) from the **A** port on the Single Bank Hydraulic Valve to the front port on the Cylinder.
12. Disconnect the negative (-) ground battery cable from the battery. Place a drain pan under the valve on the machine. **ENGINE MUST BE COOL BEFORE DISCONNECTING THE HOSES.**
13. Disconnect the hose from the **I** port on the 2 Bank Valve (Ref # 32) and the **top** port on the Oil Cooler. Discard this hose, it will not be used. Connect the 75" Hose (Ref # 34) from the **I** port on the Single Bank Valve to the top port on the Oil Cooler. *This hose may be a bit long on the Gasoline Models so you may have to loop the hose around the back of the pump to use up some hose.* Connect the 57 $\frac{1}{2}$ " Hose (Ref # 31) from the **P** port of the Single Bank Valve to the **I** port of the 2 Bank Valve. Tie up Hoses using $\frac{5}{8}$ Loom Clamp (Ref # 28). Route the 57 $\frac{1}{2}$ " & 75" Hoses under the body and along the frame avoiding any pinch points. Fasten to the frame using the 14 $\frac{1}{2}$ " Nylon Ties.
14. Reconnect the negative (-) ground battery cable to battery.
15. Make sure that everything is clear of the machine. Start the machine, work the valve so that the plow will both raise and lower. Also, do this with both the attachment lift and the rake lift. Work the lift a number of times until all air works out of the plow circuit and the cylinder works smoothly. At this time look for hydraulic leaks. If there are leaks, turn engine off and repair, start up and check again.
16. Check the hydraulic oil level. The level should be 2" to 2 $\frac{1}{2}$ " below the top of the tank. If more is needed, use SAE 10W-40 API service SG motor oil.

42-011-AB ALUMINUM SAND PLOW DRAWING

42-011-SB STEEL SAND PLOW DRAWING

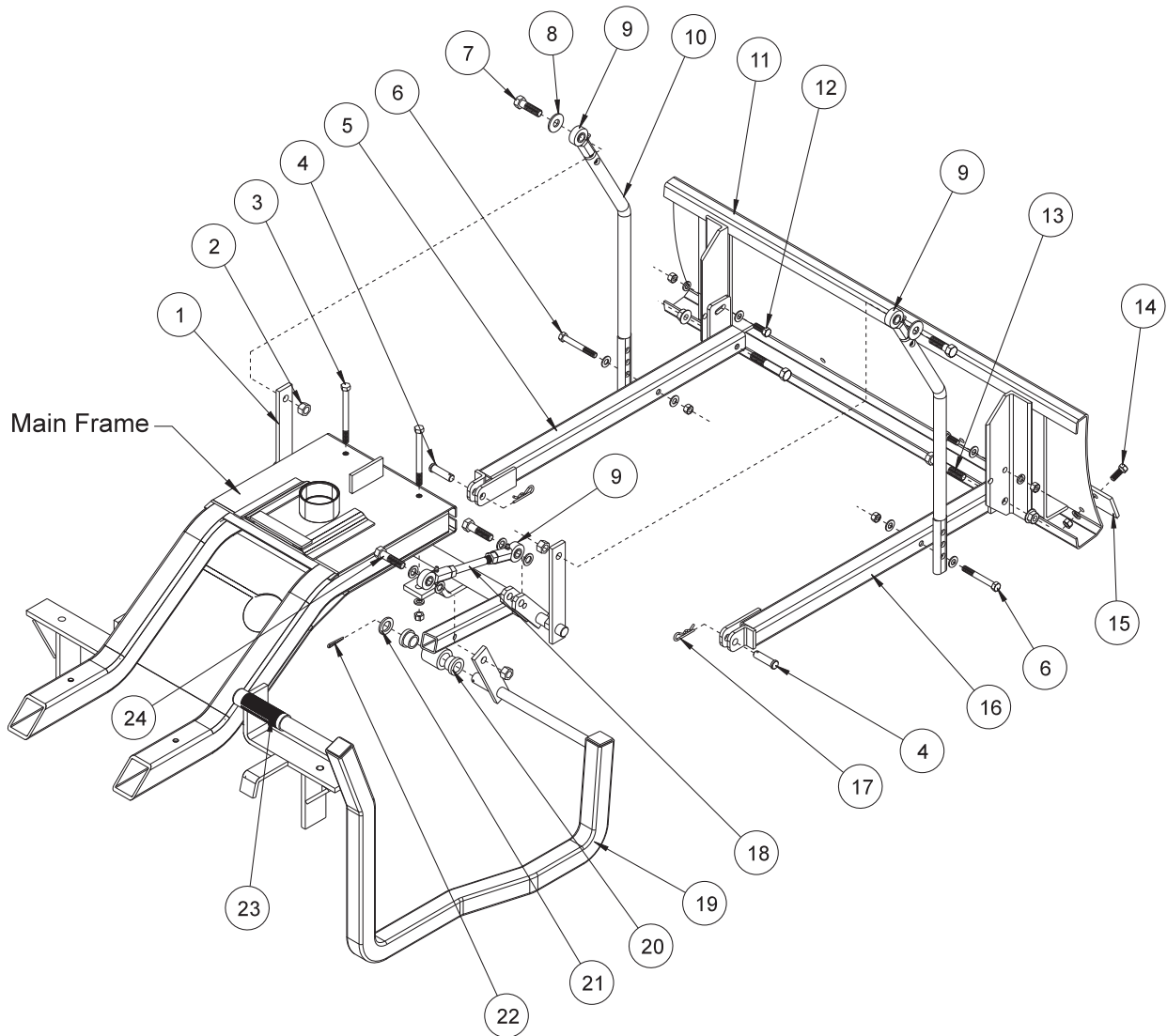

Accessories

42-011 SAND PLOW PARTS LIST

REF#	PART#	DESCRIPTION	QUANTITY
1	42-346	Lift Assembly (includes Ref# 20)	1
2	HNTL-12-13	Lock Nut 1/2 - 13	2
3	HB-38-16-350	Bolt 3/8 - 16 x 3 1/2 (part of main frame)	2
	HWL-38	Lock Washer 3/8	2
	HN-38-16	Nut 3/8 - 16	2
4	HCP-12-150	Clevis Pin 1/2 x 1 1/2	2
5	27-049	Left Pusher Bar	1
6	HB-38-16-300	Bolt 3/8 - 16 x 3	2
	HW-38	Washer 3/8	4
	HNTL-38-16	Lock Nut 3/8 - 16	2
7	HB-12-13-200	Bolt 1/2 - 13 x 2	2
8	HMB-12-14	Machine Bushing 1/2 x 14GA	8
9	80-006	Rod End	4
	HNJ-12-20	Jam Nut 1/2 - 20	4
10	27-073	Lift Rod	2
11	27-017	Aluminum Sand Plow Blade	1
	13-352	Steel Sand Plow Blade	1
12	HB-38-16-100	Bolt 3/8 - 16 x 1	2
	HW-38	Washer 3/8	2
	HWL-38	Lock Washer 3/8	2
	HN-38-16	Nut 3/8 - 16	2
13	HB-12-13-300	Bolt 1/2 - 13 x 3	2
	HNTL-12-13	Lock Nut 1/2 - 13	2
14	HB-38-16-100	Bolt 3/8 - 16 x 1	4
	HNFL-38-16	Flange Whiz Lock Nut 3/8 - 16	4
15	13-167	Wear Blade	1
16	27-050	Right Pusher Bar	1
17	HHP-18	Bridge Pin 1/8	2
18	42-348	Rod	1
19	42-347	Lift Handle	1
20	18-221	Flange Bushing	2
21	HMB-34-14	Machine Bushing 3/4 - 14GA	1
22	HP-18-150	Cotter Pin 1/8 x 1 1/2	1
23	15-019	Grip	1
24	HB-12-13-200	Bolt 1/2 - 13 x 2	2

INSTALLATION INSTRUCTIONS

- Assemble the pusher bars (Ref 5 and 16) to the plow (Ref 11) using hardware (Ref 12 & 13). There are 2 holes to bolt the hardware in. Using hole closest to the blade will result in a shallow cut, whereas using the hole furthest from the blade will result in a deeper cut. The slot on the pusher bar is for fine tuned adjustment.
- Assemble the lift assembly (Ref 1) to the main frame using the two studs that are under the frame and below the front of the console.
- Attach the lift handle (Ref 19) to the lift assembly using cotter pin and machine bushing (Ref 21 & 22). Using rod and yoke (Ref 18 & 9) attach the handle to the lift assembly.
- Put rod ends (Ref 9) onto lift rods (Ref 10) with jam nut first. Adjust to equal lengths. Bolt lift rods to lift arms with ball joints to the outside. Bolt from outside with the 1/2" machine bushing between rod end and lift arm and the 1/2 -13 nylon lock nut on the inside. Use (Ref 7) hardware.
- Slide Plow under machine and connect to machine. Use clevis pin and bridge pin (Ref 4 & 17).
- Lift up the plow. Using the top hole in the lift rod as a starting point hook on the pusher bars. Use (Ref 6) hardware. The three holes in the lift rods are for adjusting the hand lever. The top hole moves the lever forward and holds the blade with the most clearance. Each hole down moves the lever to the rear of the machine and decreases blade clearance by approximately one inch.
- For fine tuning of blade height off ground twist rod end (Ref 9) on rod (Ref 18). Twisting the rod end out will increase down pressure. Twisting the rod end onto the rod will decrease down pressure.



42-136 60" SAND PLOW DRAWING

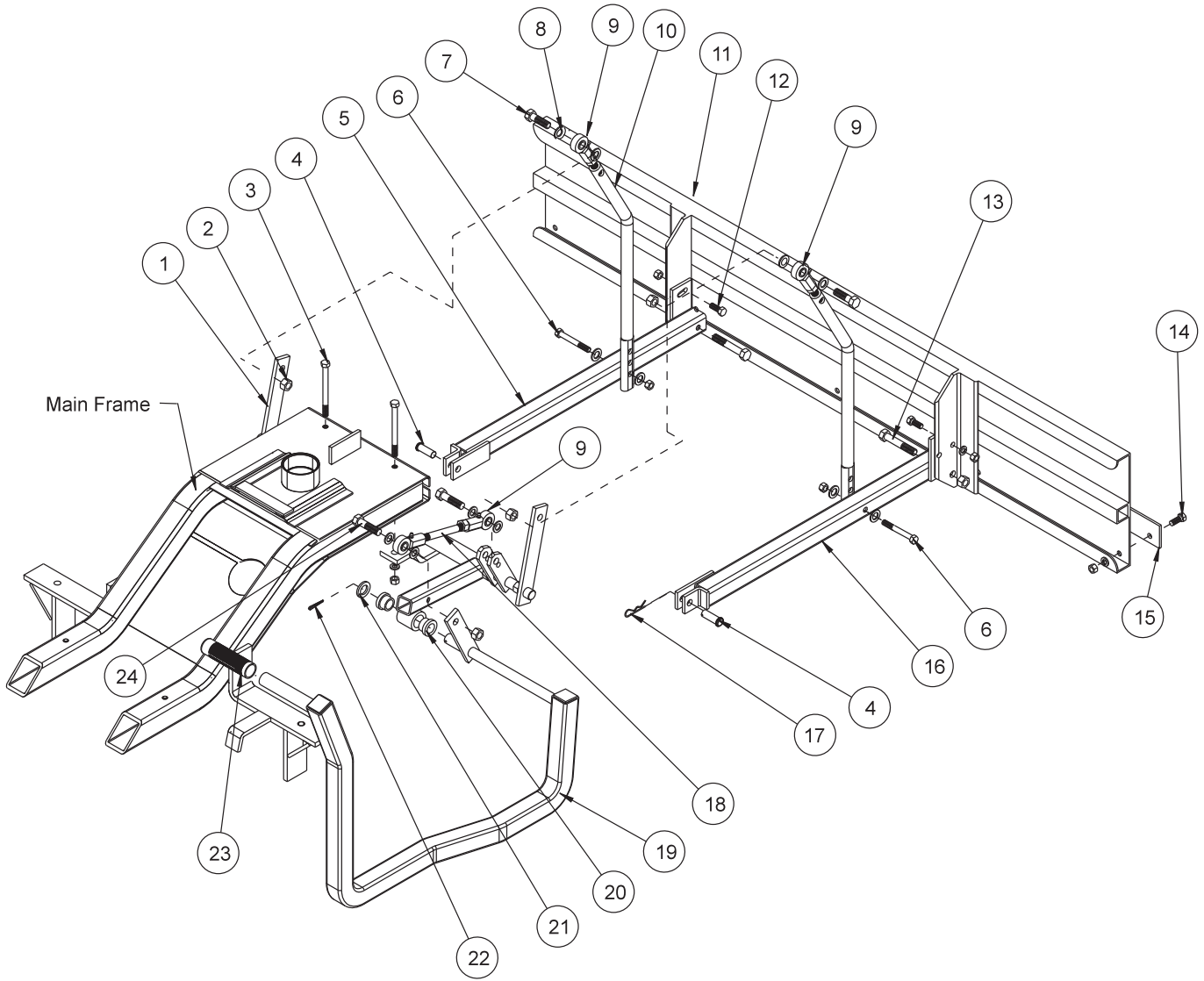

Accessories

42-136 60" SAND PLOW PART LIST

REF#	PART#	DESCRIPTION	QUANTITY
1	42-092	Lift Assembly (includes Ref# 20)	1
2	HNTL-12-13	Lock Nut 1/2 - 13	4
3	HB-38-16-350	Bolt 3/8 - 16 x 3 1/2 (part of main frame)	2
	HWL-38	Lock Washer 3/8	2
	HN-38-16	Nut 3/8 - 16	2
4	HCP-12-150	Clevis Pin 1/2 x 1 1/2	2
5	27-049	Left Pusher Bar	1
6	HB-38-16-300	Bolt 3/8 - 16 x 3	2
	HW-38	Washer 3/8	4
	HNTL-38-16	Lock Nut 3/8 - 16	2
7	HB-12-13-200	Bolt 1/2 - 13 x 2	2
8	HMB-12-14	Machine Bushing 1/2 x 14GA	8
9	80-006	Rod End	4
	HNJ-12-20	Jam Nut 1/2 - 20	4
10	27-073	Lift Rod	2
11	35-011	Aluminum Plow Blade 60"	1
12	HB-38-16-100	Bolt 3/8 - 16 x 1	2
	HW-38	Washer 3/8	2
	HWL-38	Lock Washer 3/8	2
	HN-38-16	Nut 3/8 - 16	2
13	HB-12-13-300	Bolt 1/2 - 13 x 3	2
	HNTL-12-13	Lock Nut 1/2 - 13	2
14	HB-38-16-100	Bolt 3/8 - 16 x 1	5
	HWL-38	Lock Washer 3/8	5
	HN-38-16	Nut 3/8 - 16	5
15	35-012	Wear Blade	1
16	27-050	Right Pusher Bar	1
17	HHP-18	Bridge Pin 1/8	2
18	42-094	Rod	1
19	42-093	Lift Handle	1
20	18-221	Flange Bushing	2
21	HMB-34-14	Machine Bushing 3/4 - 14GA	1
22	HP-18-150	Cotter Pin 1/8 x 1 1/2	1
23	15-019	Grip	1
24	HB-12-13-200	Bolt 1/2 - 13 x 2	2

INSTALLATION INSTRUCTIONS

- Assemble pusher bars (Ref 5 and 16) to plow (Ref 11) using hardware (Ref 12 & 13). There are 2 holes to bolt the hardware in. Using hole closest to the blade will result in a shallow cut, whereas using the hole furthest from the blade will result in a deeper cut. The slot on the pusher bar is for fine tuned adjustment.
- Assemble the lift assembly (Ref 1) to the main frame using the two studs that are under the frame and below the front of the console.
- Attach the lift handle (Ref 19) to the lift assembly using cotter pin and machine bushing (Ref 21 & 22). Using rod and yoke (Ref 18 & 9) attach the handle to the lift assembly.
- Put rod ends (Ref 9) onto lift rods (Ref 10) with jam nut first. Adjust to equal lengths. Bolt lift rods to lift arms with ball joints to the outside. Bolt from outside with the 1/2" machine bushing between rod end and lift arm and the 1/2 -13 nylon lock nut on the inside. Use (Ref 7) hardware.
- Slide plow under machine and connect to machine. Use clevis pin and bridge pin (Ref 4 & 17).
- Lift up the plow. Using the top hole in the lift rod as a starting point hook on the pusher bars. Use (Ref 6) hardware. The three holes in the lift rods are for adjusting the hand lever. The top hole moves the lever forward and holds the blade with the most clearance. Each hole down moves the lever to the rear of the machine and decreases blade clearance by approximately one inch.
- For fine tuning of blade height off ground twist rod end (Ref 9) on rod (Ref 18). Twisting the rod end out will increase down pressure. Twisting the rod end onto the rod will decrease down pressure.



42-223 ADJUSTABLE DISC EDGER DRAWING

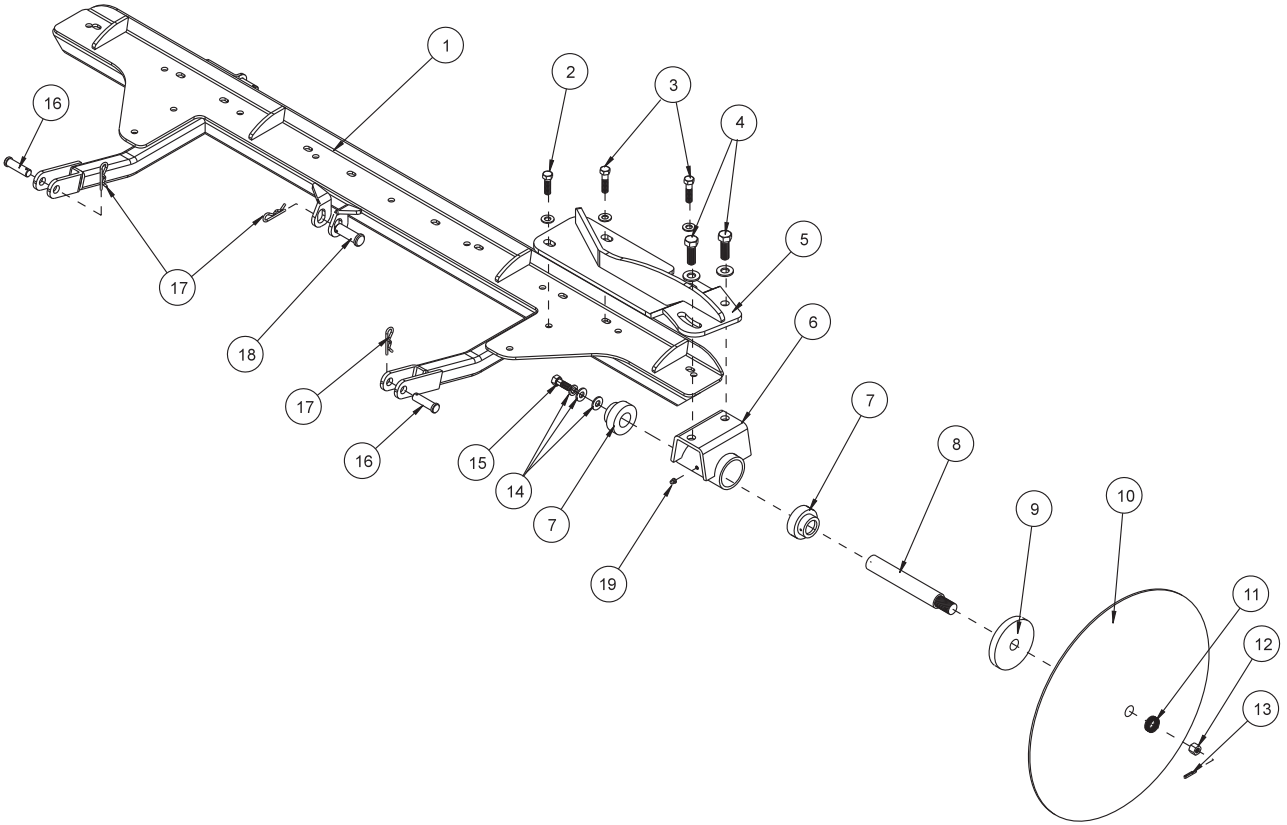

Accessories

42-223 ADJUSTABLE DISC EDGER PARTS LIST

REF#	PART#	DESCRIPTION	QUANTITY
1	42-203	Attachment Lift Assembly	1
2	HB-38-16-125	Bolt $\frac{3}{8}$ - 16 x $1\frac{1}{4}$	1
	HW-38	Washer $\frac{3}{8}$	1
	HNTL-38-16	Lock Nut $\frac{3}{8}$ -16	1
3	HB-38-16-150	Bolt $\frac{3}{8}$ - 16 x $1\frac{1}{2}$	2
	HW-38	Washer $\frac{3}{8}$	2
	HNTL-38-16	Lock Nut $\frac{3}{8}$ - 16	2
4	HB-12-13-150	Bolt $\frac{1}{2}$ - 13 x $1\frac{1}{2}$	2
	HW-12	Washer $\frac{1}{2}$	2
	HNTL-12-13	Lock Nut $\frac{1}{2}$ - 13	2
5	42-224	Edger Mount	1
6	13-203	Spindle	1
7	13-391	Bearing and Collar	2
8	13-206	Spindle Shaft	1
9	13-205	$\frac{1}{2}$ Disc Flange	1
10	13-204	Disc	1
11	HMB-34-10	Machine Bushing $\frac{3}{4}$ x 10GA	4
12	HNA-34-16	Axle Nut $\frac{3}{4}$ - 16	1
13	HP-18-150	Cotter Pin $\frac{1}{8}$ x $1\frac{1}{2}$	1
14	HWL-38	Washer $\frac{3}{8}$	1
	HW-516	Washer $\frac{5}{16}$	1
	HW-716	Washer $\frac{7}{16}$	1
15	HB-38-16-100	Bolt $\frac{3}{8}$ -16 x 1	1
16	HCP-12-200	Clevis Pin $\frac{1}{2}$ x 2	2
17	HHP-18	Bridge Pin $\frac{1}{8}$	3
18	HCP-58-250	Clevis Pin $\frac{5}{8}$ x $2\frac{1}{2}$	1
19	HG-14-28-180	Grease Fitting $\frac{1}{4}$ - 28 x 180	1

INSTALLATION INSTRUCTIONS

1. For initial assembly, bolt spindle assembly (Ref 6) to the edger mount (Ref 5). Use the $\frac{1}{2}$ - 13 bolts, washers and lock nuts (Ref 4) to hold in place.
2. Make sure the $\frac{1}{2}$ " disc flange (Ref 9) is on the spindle shaft (Ref 8) up to the shoulder. Then place the disc (Ref 10) onto the shaft, curved towards the spindle housing, followed by four machine bushings (Ref 11), and the axle nut (Ref 12).
3. Tighten axle nut and slide in the cotter pin (Ref 13).
4. The edger mount mounts onto the attachment lift assembly (Ref 1). Use the $\frac{3}{8}$ bolts, washers and lock nuts (Ref 2 and 3) with the $1\frac{1}{4}$ " bolt going into the last hole on the mount plate.
5. The Edger mounts under the center of the trap rake.
6. Place the handle and linkage onto the empty linkage port of the two bank valve on the machine.
7. Start the engine and lower the cylinder for the attachment lift FULLY. Stop engine.
8. Slide Edger under the trap rake from the right side.
9. Position the lift arms on the attachment lift assembly to the lift brackets on the machine. Hold in place with $\frac{1}{2}$ x 2 clevis pin and bridge pins (Ref 16 and 17).
10. Attach the cylinder to the center tab on the attachment lift assembly using the $\frac{5}{8}$ x $2\frac{1}{2}$ clevis pin and bridge pin (Ref 17 and 18).
11. Start engine and test lift and Edger to make sure all works well.

42-008 SAND CULTIVATOR DRAWING

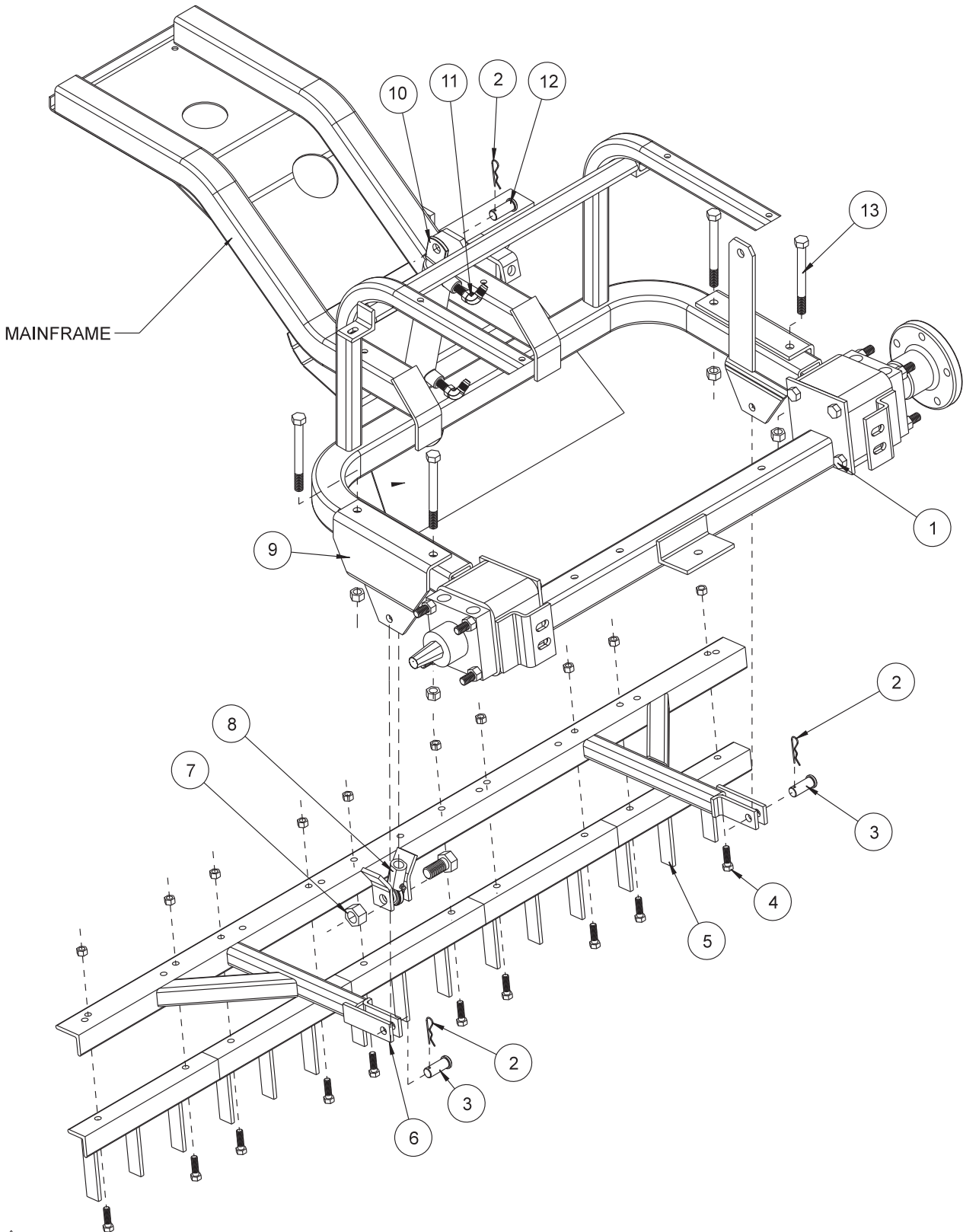

Accessories

42-008 SAND CULTIVATOR PARTSLIST

REF#	PART#	DESCRIPTION	QTY
1	HCP-58-175	Clevis Pin $\frac{5}{8}$ - $1\frac{3}{4}$	1
2	10-135	Hydraulic Cylinder	1
3	18-168	90° Elbow	2
4	42-217	Cylinder Mount	1
5	HB-12-13-500	Bolt $\frac{1}{2}$ - 13 x 5	4
	HNTL-12-13	Lock Nut $\frac{1}{2}$ - 13	4
6	42-015	Attachment Mount	2
*7	HHP-18	Bridge Pin $\frac{1}{8}$	3
*9	HB-38-16-125	Bolt $\frac{3}{8}$ - 16 x $1\frac{1}{4}$	10
	HNTL-38-16	Lock Nut $\frac{3}{8}$ - 16	10
*10	42-038	Tine Segment	5
*11	HCP-12-200	Clevis Pin $\frac{1}{2}$ x 2	2
*12	42-203	Attachment Lift	1
*13	HCP-58-250	Clevis Pin $\frac{5}{8}$ x $2\frac{1}{2}$	1
14	18-154	Rod End	1
*	42-008	Sand Cultivator (all other parts reference only)	

INSTALLATION INSTRUCTIONS

1. Install valve handle with linkage (13-672) onto valve.
2. Remove the cylinder mount (Ref 4) from the machine.
3. Tine Segments (Ref 10) should be bolted to the attachment lift (Ref 12). Attach the attachment lift to (Ref 12) attachment mount using (Ref 11 & 7) clevis pin and bridge pin.
4. Lift attachment lift up or extend cylinder so rod end (Ref 14) lines up with the holes on the center of the attachment lift. Use clevis pin and bridge pin (Ref 7 and 13) to fasten cylinder to sand cultivator.
6. Turn machine on and test for proper operation.

42-340 SAND CULTIVATOR WITH SPRING TINES DRAWING

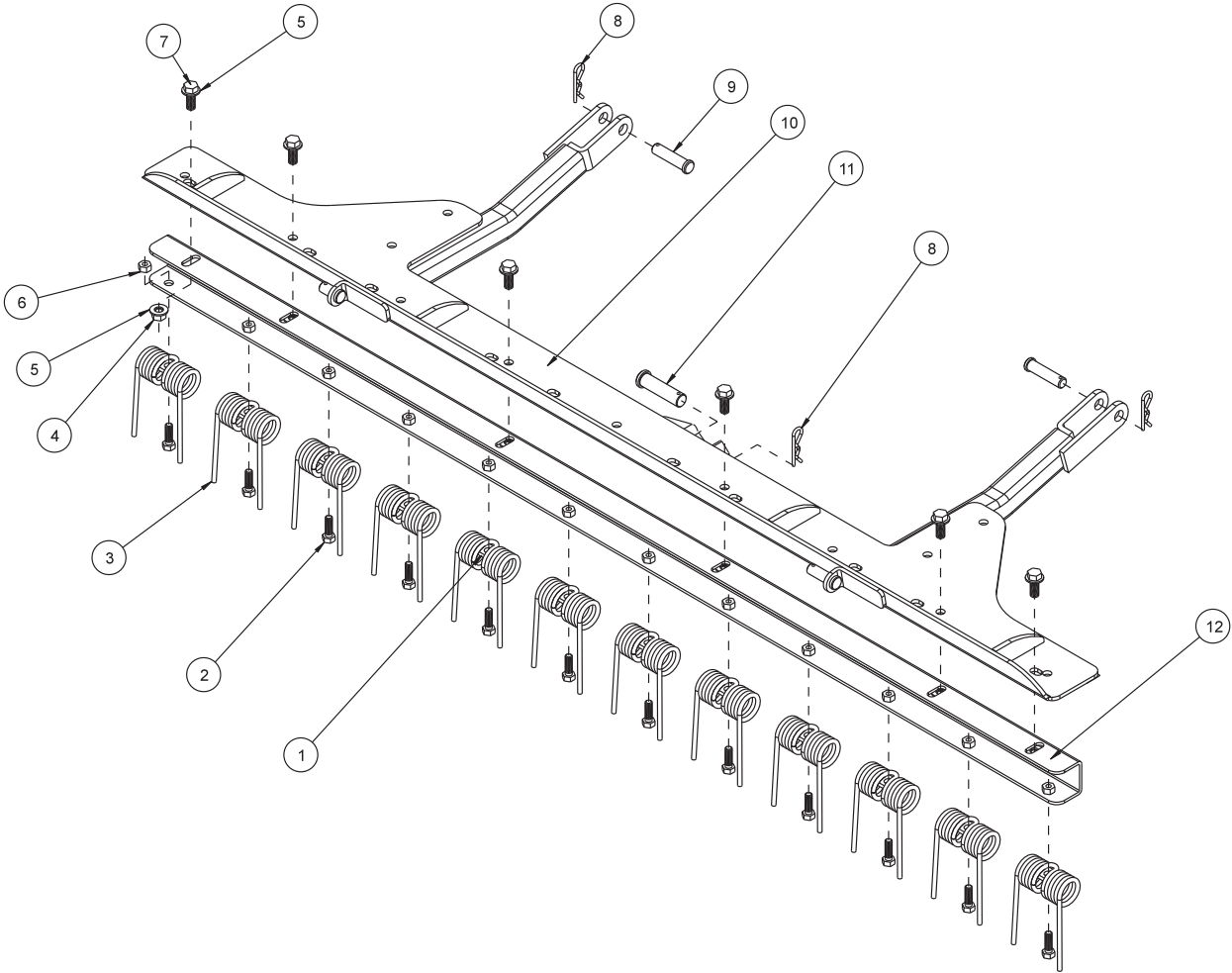

Accessories

42-340 SAND CULTIVATOR WITH SPRING TINES PARTSLIST

REF#	PART#	DESCRIPTION	QUANTITY
1	42-177	Spring Holder	12
2	HB-516-18-100	Hex Bolt $\frac{5}{16}$ - 18 x 1	12
3	42-122	Rake Spring	12
4	HNTL-38-16	Lock Nut $\frac{3}{8}$ - 16	6
5	HW-38	Flat Washer $\frac{3}{8}$	12
6	HNTL-516-18	Lock Nut $\frac{5}{16}$ - 18	12
7	HB-38-16-100	Hex Bolt $\frac{3}{8}$ - 16 x 1	6
8	HHP-18	Bridge Pin $\frac{1}{8}$	3
9	HCP-12-200	Clevis Pin $\frac{1}{2}$ x 2	2
10	42-203	Attachment Lift Bar	1
11	HCP-58-250	Clevis Pin $\frac{5}{8}$ x $2\frac{1}{2}$	1
12	42-343	Spring Bar	1

42-341 FIELD SCARIFIER WITH TINES AND CASTOR WHEELS DRAWING

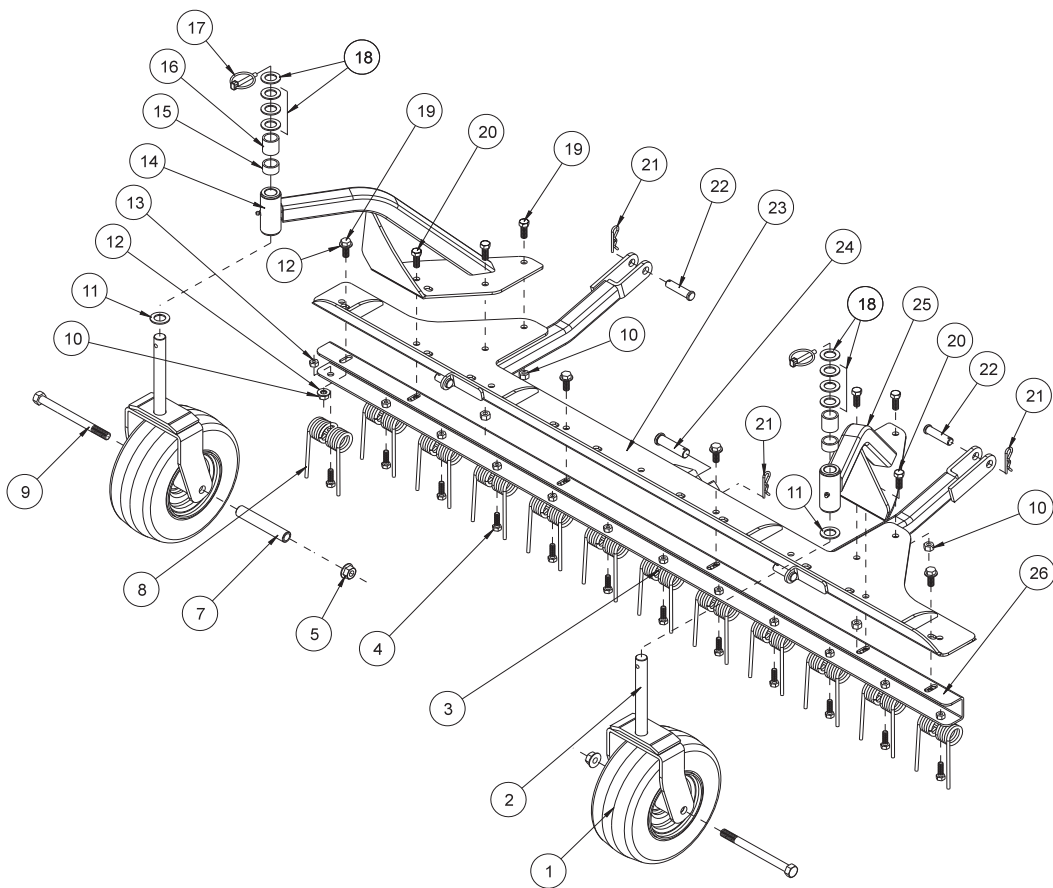

Accessories

42-341 FIELD SCARIFIER WITH TINES AND CASTOR WHEELS PARTS LIST

REF#	PART#	DESCRIPTION	QUANTITY
1	42-202	Tire & Wheel	2
	42-202-01	Tire 9 x 3.5 x 4 PLY (Part of 42-202)	2
	42-202-02	Wheel (Part of 42-202)	2
	42-202-03	Cap (Part of 42-202)	4
	42-202-04	Bearing (Part of 42-202)	4
	42-202-05	Seal (Part of 42-202)	4
2	42-204	Castor Fork	2
3	42-177	Spring Holder	12
4	HB-516-18-100	Hex Bolt $\frac{5}{16}$ - 18 x 1	12
5	HNTL-12-13	Lock Nut $\frac{1}{2}$ - 13	2
6	42-212	Castor Wheel Spacer	4
7	42-213	Axle Bearing	2
8	42-122	Rake Spring	12
9	HB-12-13-600	Hex Bolt $\frac{1}{2}$ - 13 x 6	2
10	HNTL-38-16	Lock Nut $\frac{3}{8}$ - 16	10
11	HMB-34-14	Machine Bushing $\frac{3}{4}$ x 14GA	2
12	HW-38	Flat Washer $\frac{3}{8}$	12
13	HNTL-516-18	Lock Nut $\frac{5}{16}$ - 18	12
14	42-289	Right Castor Wheel Bracket	1
	10-025	Flange Bushing (Part of 42-289)	2
	HG-14-28-180	Grease Fitting $\frac{1}{4}$ - 28 x 180° (Part of 42-289)	1
15	42-215	Short Spacer	2
16	42-214	Long Spacer	2
17	42-539	Lynch Pin $\frac{1}{4}$ "	2
18	HMB-34-10	Machine Bushing $\frac{3}{4}$ x 10GA	8
19	HB-38-16-100	Hex Bolt $\frac{3}{8}$ - 16 x 1	8
20	HB-38-16-125	Hex Bolt $\frac{3}{8}$ - 16 x 1 $\frac{1}{4}$	2
21	HHP-18	Bridge Pin $\frac{1}{8}$	3
22	HCP-12-200	Clevis Pin $\frac{1}{2}$ x 2	2
23	42-203	Attachment Lift Bar	1
24	HCP-58-250	Clevis Pin $\frac{5}{8}$ x 2 $\frac{1}{2}$	1
25	42-288	Left Castor Wheel Bracket	1
	10-025	Flange Bushing (Part of 42-288)	2
	HG-14-28-180	Grease Fitting $\frac{1}{4}$ - 28 x 180° (Part of 42-288)	1
26	42-343	Spring Bar	1

42-010 CONSTRUCTION LEVELING BLADE DRAWING

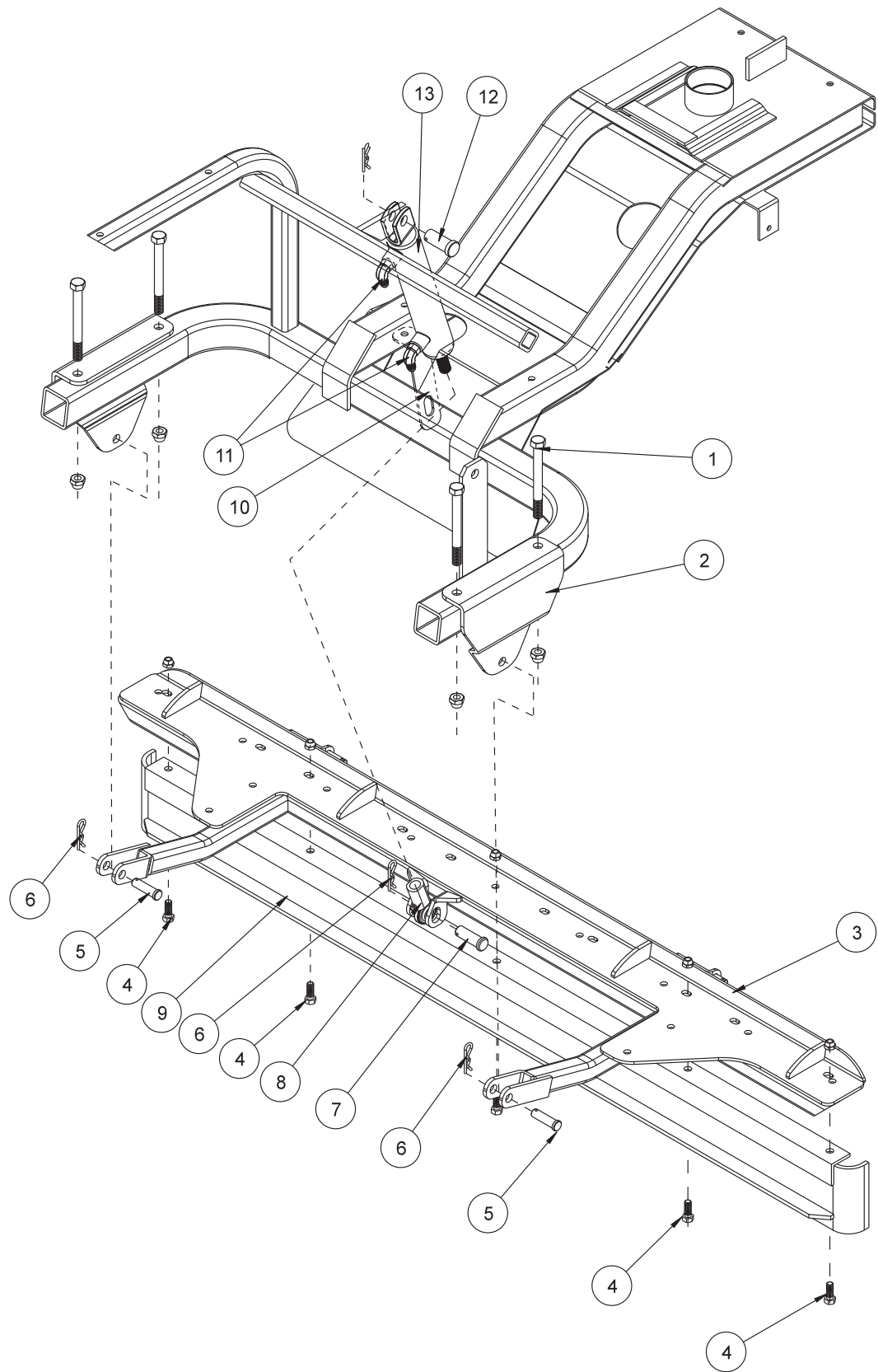

Accessories

42-010 CONSTRUCTION LEVELING BLADE PARTS LIST

REF#	PART#	DESCRIPTION	QUANTITY
1	HB-12-13-500	Bolt $\frac{1}{2}$ - 13 x 5	4
	HNTL-12-13	Lock Nut $\frac{1}{2}$ - 13	4
2	42-015	Attachment Mount	2
*3	42-203	Attachment Lift	1
*4	HB-38-16-100	Bolt $\frac{3}{8}$ - 16 x 1	5
	HNTL-38-16	Lock Nut $\frac{3}{8}$ - 16	5
*5	HCP-12-200	Clevis Pin $\frac{1}{2}$ x 2	2
*6	HHP-18	Bridge Pin $\frac{1}{8}$	3
*7	HCP-58-250	Clevis Pin $\frac{5}{8}$ x $2\frac{1}{2}$	1
8	18-154	Rod End	1
*9	42-097	Leveling Blade	1
10	42-217	Cylinder Mount	1
11	18-168	90° Elbow	2
12	HCP-34-175	Clevis Pin $\frac{3}{4}$ - $1\frac{3}{4}$	1
13	10-135	Hydraulic Cylinder	1
*	42-010	Construction Leveling Blade (all other parts are reference only)	

INSTALLATION INSTRUCTIONS

1. Remove the cylinder mount (Ref 10) from the machine.
2. Bolt leveling blade (Ref 9) to attachment lift (Ref 3) using five $\frac{3}{8}$ - 16 x 1 bolts and five $\frac{3}{8}$ - 16 lock nuts as shown on drawing.
3. Attach the attachment lift to attachment mount (Ref 3) using clevis pin and bridge pin (Ref 5 and 6).
4. Lift attachment lift up or extend cylinder so rod end (Ref 8) lines up with the holes on the center of the attachment lift. Use $\frac{5}{8}$ x $2\frac{1}{2}$ clevis pin and bridge pin (Ref 6 & 7) to fasten cylinder to cultivator.
5. Turn machine on and test for proper operation.

42-210 GRADER BLADE DRAWING

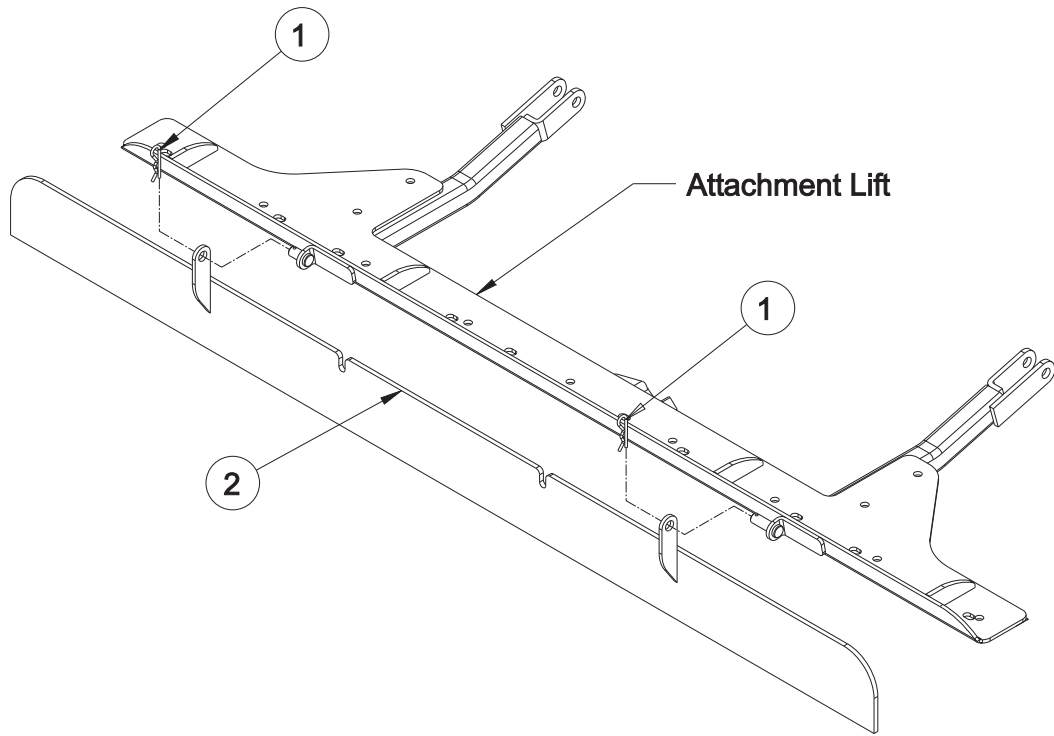

BLADE CLIP DRAWING

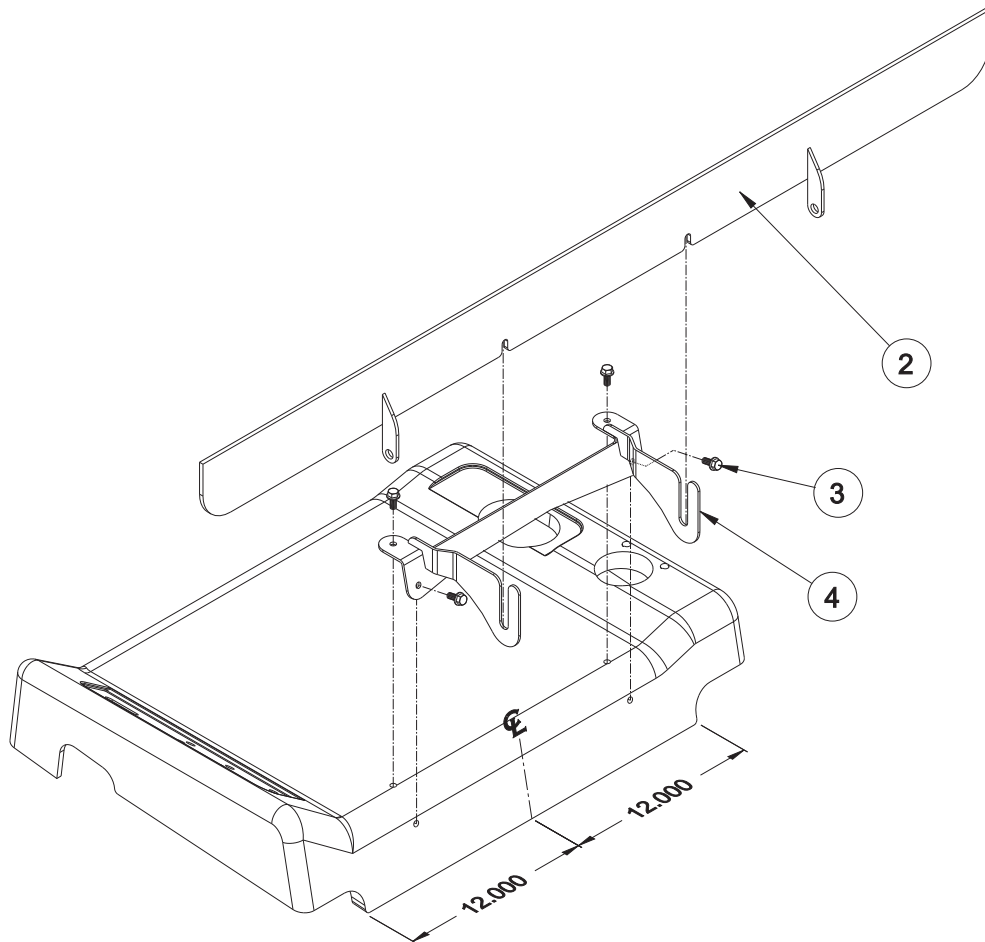

Accessories

42-210 GRADER BLADE PARTS LIST

REF#	PART#	DESCRIPTION	QTY
1	HHP-18	Bridge Pin $\frac{1}{8}$	2
2	42-207	Grader Blade	1
3	HBFL-516-18-075	Flange Bolt, $\frac{5}{16}$ - 18 x $\frac{3}{4}$	4
	HNFL-516-18	Flange Whiz-Loc Nut, $\frac{5}{16}$ - 18 (not illustrated)	4
4	42-386	Grader Blade Mount	1

INSTALLATION INSTRUCTIONS

1. Install Grader Blade (Ref 2) onto Attachment Lift by sliding tabs onto clevis pins and secure with Bridge Pins (Ref 1).
2. Install Grader Blade Mount (Ref 4) on seat panel.
3. Position the Grader Blade Mount (Ref 4) to be centered on the rear of the Seat Panel as illustrated. Mark the hole locations on the Seat Panel. Using an $\text{Ø}^{11/32}$ drill located the holes at the four marks made previously. The top two holes will be drilled through the fiberglass and the steel panel and the rear holes will be drilled through the fiberglass only.
4. Bolt the Grader Blade Mount (Ref 4) to the Seat Panel using the four $\frac{5}{16}$ -18 Flange Bolts and Flange Nuts (Ref 3).
5. The Grader Blade Mount is used for the storage of the Grader Blade when not in use. To store, turn the Grader Blade to the position illustrated in the **Grader Blade Mount Drawing** and place in the Grader Blade Mount.
6. Turn machine on and test for proper operation.



42-178 INFIELD SCARIFIER WITH VERTICAL BLADES DRAWING

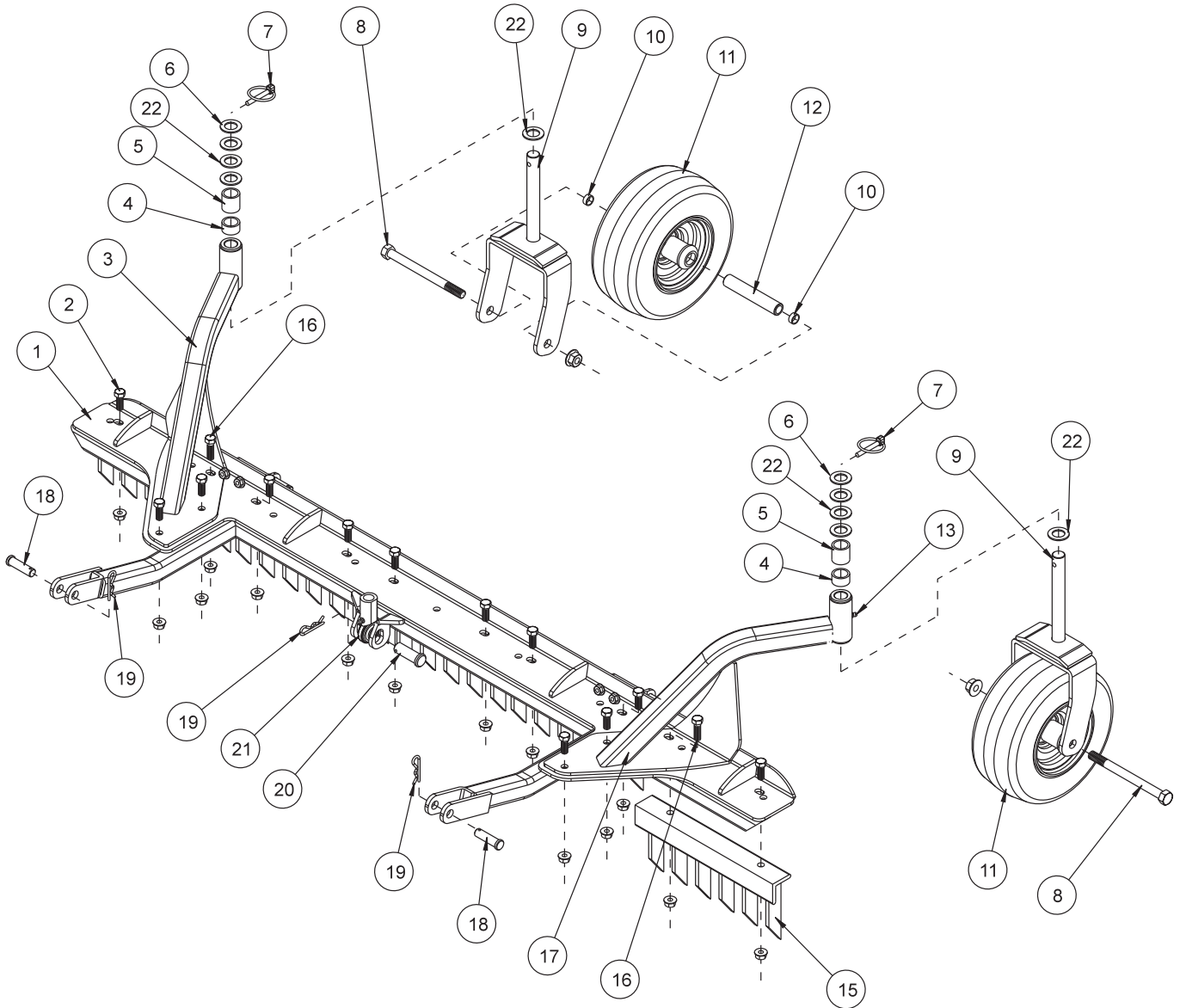

Accessories

42-178 INFIELD SCARIFIER WITH VERTICAL BLADES PARTS LIST

REF#	PART#	DESCRIPTION	QUANTITY
1	42-203	Attachment Lift Assembly	1
2	HB-38-16-100	Bolt $\frac{3}{8}$ - 16 x 1	12
	HNTL-38-16	Lock Nut $\frac{3}{8}$ - 16	12
3	42-205	Left Castor Wheel Bracket	1
	10-025	Bushing (part of 42-205)	2
4	42-215	Short Spacer	2
5	42-214	Long Spacer	2
6	HMB-34-14	Machine Bushing $\frac{3}{4}$ x 14GA	2
7	42-539	Lynch Pin $\frac{5}{16}$	2
8	HB-12-13-600	Bolt $\frac{1}{2}$ -13 x 6	2
	HNTL-12-13	Lock Nut $\frac{1}{2}$ - 13	2
9	42-204	Castor Fork	2
10	42-212	Castor Wheel Spacer	4
11	42-202	Tire and Wheel	2
	42-202-01	Tire 9 x 3.5 x 4 Ply	2
	42-202-02	Wheel	2
	42-202-03	Cap	2
	42-202-04	Bearing	2
	42-202-05	Seal	2
12	42-213	Axle Bearing	2
13	HG-14-28-180	Grease Fitting $\frac{1}{4}$ - 28 x 180° (part of 42-205 and 42-206)	2
15	26-042	Tine Segment	5
16	HB-38-16-125	Bolt $\frac{3}{8}$ - 16 x $1\frac{1}{4}$	2
	HNTL-38-16	Lock Nut $\frac{3}{8}$ - 16	2
17	42-206	Right Castor Wheel Bracket	1
	10-025	Bushing (part of 42-205)	2
18	HCP-12-200	Clevis Pin $\frac{1}{2}$ x 2	2
19	HHP-18	Bridge Pin $\frac{1}{8}$	3
20	HCP-58-250	Clevis Pin $\frac{5}{8}$ x $2\frac{1}{2}$	1
21	18-154	Rod End (part of machine)	1
22	HMB-34-10	Machine Bushing $\frac{3}{4}$ x 10GA	8

42-178 SCARIFIER MOUNTING DRAWING

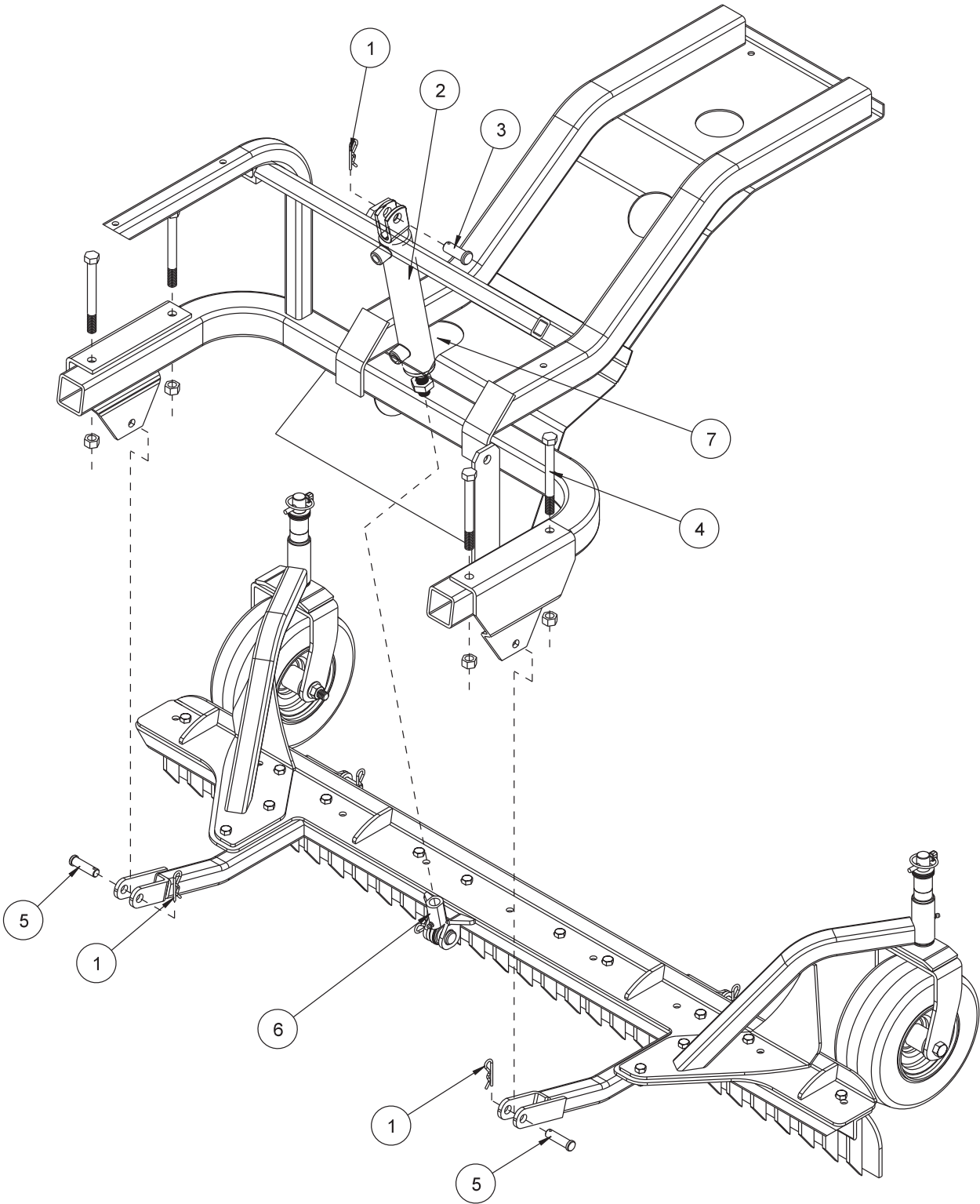

Accessories

42-178 SCARIFIER MOUNTING PARTS LIST

REF#	PART#	DESCRIPTION	QUANTITY
1	HHP-18	Bridge Pin $\frac{1}{8}$	3
2	10-135	Hydraulic Cylinder (part of machine)	1
3	HCP-58-175	Clevis Pin $\frac{5}{8} \times 1\frac{3}{4}$	1
4	HB-12-13-500	Bolt $\frac{1}{2}$ - 13 x 5	4
	HNTL-12-13	Lock Nut $\frac{1}{2}$ - 13	4
5	HCP-12-200	Clevis Pin $\frac{1}{2}$ - 2	2
6	18-154	Rod End (part of machine)	1
7	42-217	Cylinder Mount (part of machine)	1

INSTALLATION INSTRUCTIONS

1. Assemble the Scarifier as shown on previous page.
2. Remove the rod end (Ref 6) on the hydraulic cylinder (Ref 2) from the cylinder mount (Ref 7). Remove the cylinder mount (Ref 7) from the machine.
- *3. Place the handle and linkage onto the empty linkage port of the two bank valve on the machine.
4. Slide the Scarifier under the machine lining up the hydraulic cylinder and the center of the attachment lift assembly.
5. Extend hydraulic cylinder all the way down by pushing the lever forward.
6. Mount the rod end of the cylinder onto the attachment lift assembly and secure with a clevis pin and bridge pin.
7. Attach the arms on the attachment lift to the attachment mount on the machine and secure with clevis pin and bridge pin.
8. Turn machine on and test for proper operation.
9. Adjust castor wheels by placing the short or long spacer on the castor wheel fork before placing the castor wheel assembly into the castor wheel brackets. Be sure both castor wheels are adjusted to the same height.

* For machines prior to serial numbers 4500 (3WD) and 12500 (2WD).

42-179 INFIELD SCARIFIER WITH CHISEL BLADES DRAWING

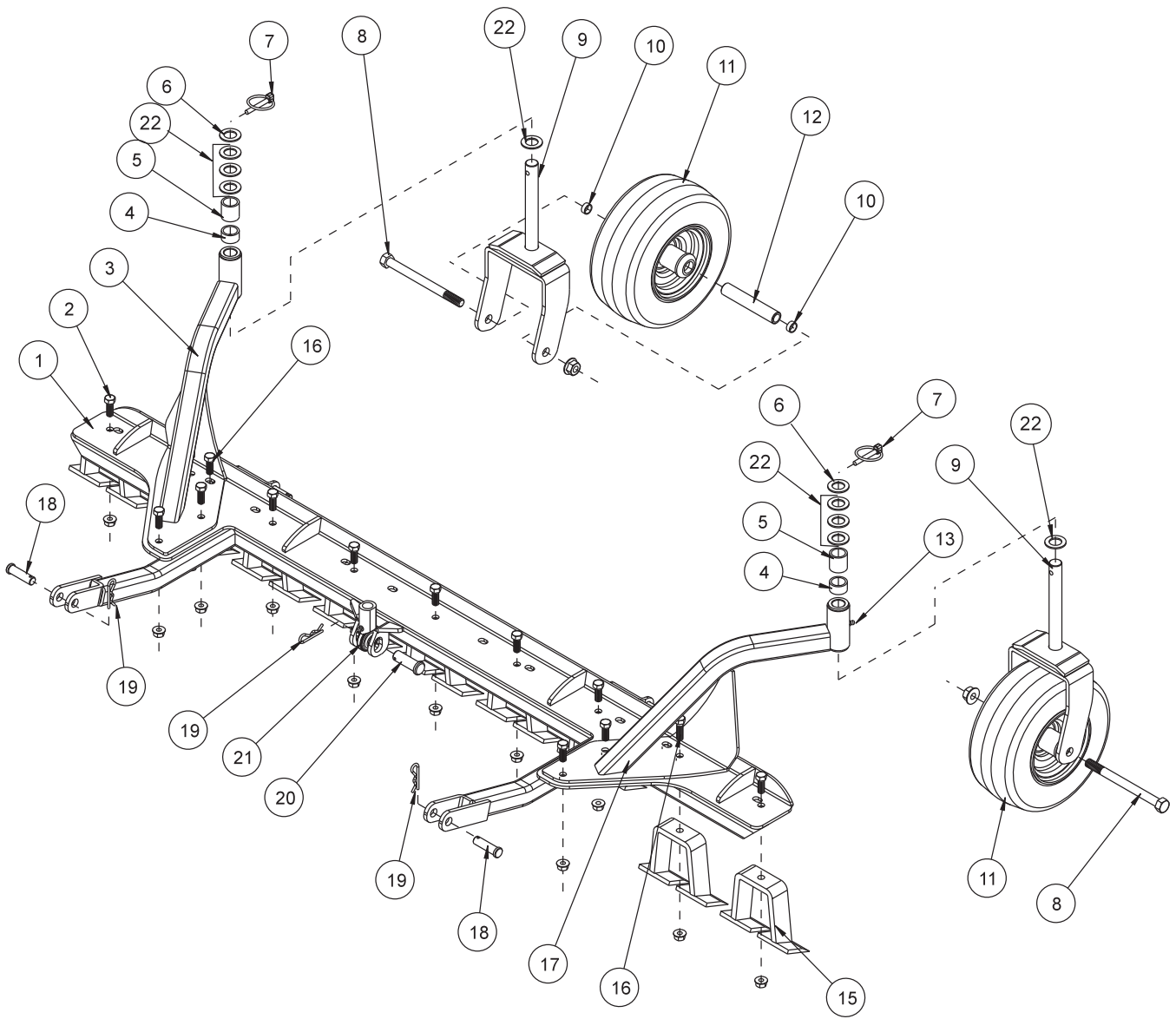

Accessories

42-179 INFIELD SCARIFIER WITH CHISEL BLADES PARTS LIST

REF#	PART#	DESCRIPTION	QUANTITY
1	42-203	Attachment Lift Assembly	1
2	HB-38-16-125	Bolt $\frac{3}{8}$ - 16 x $1\frac{1}{4}$	11
	HNTL-38-16	Lock Nut $\frac{3}{8}$ - 16	11
3	42-205	Left Castor Wheel Bracket	1
	10-025	Bushing (part of 42-205)	2
4	42-215	Short Spacer	2
5	42-214	Long Spacer	2
6	HMB-34-14	Machine Bushing $\frac{3}{4}$ x 14GA	2
7	42-539	Lynch Pin $\frac{5}{16}$	2
8	HB-12-13-600	Bolt $\frac{1}{2}$ -13 x 6	2
	HNTL-12-13	Lock Nut $\frac{1}{2}$ - 13	2
9	42-204	Castor Fork	2
10	42-212	Castor Wheel Spacer	4
11	42-202	Tire and Wheel	2
	42-202-01	Tire 9 x 3.5 x 4 Ply	2
	42-202-02	Wheel	2
	42-202-03	Cap	2
	42-202-04	Bearing	2
	42-202-05	Seal	2
12	42-213	Axle Bearing	2
13	HG-14-28-180	Grease Fitting $\frac{1}{4}$ - 28 x 180° (part of 42-205 and 42-206)	2
15	13-114	Digger Blade	9
16	HB-38-16-150	Bolt $\frac{3}{8}$ - 16 x $1\frac{1}{2}$	2
	HNTL-38-16	Lock Nut $\frac{3}{8}$ - 16	2
17	42-206	Right Castor Wheel Bracket	1
	10-025	Bushing (part of 42-205)	2
18	HCP-12-200	Clevis Pin $\frac{1}{2}$ x 2	2
19	HHP-18	Bridge Pin $\frac{1}{8}$	3
20	HCP-58-250	Clevis Pin $\frac{5}{8}$ x $2\frac{1}{2}$	1
21	18-154	Rod End (part of machine)	1
22	HMB-34-10	Machine Bushing $\frac{3}{4}$ x 10GA	8

42-179 SCARIFIER MOUNTING DRAWING

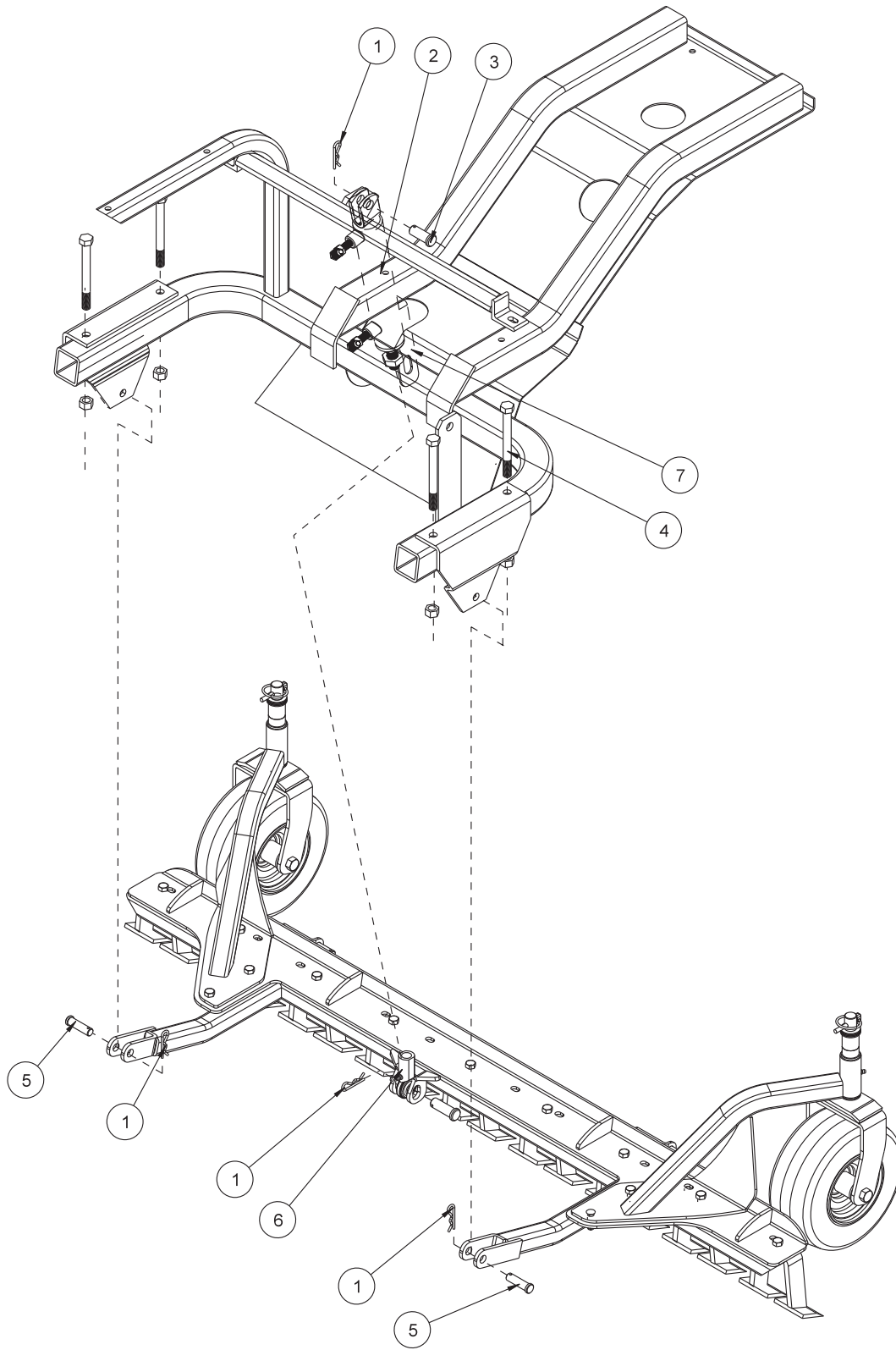

Accessories

42-179 SCARIFIER MOUNTING PARTSLIST

REF#	PART#	DESCRIPTION	QUANTITY
1	HHP-18	Bridge Pin $\frac{1}{8}$	3
2	10-135	Hydraulic Cylinder (part of machine)	1
3	HCP-58-175	Clevis Pin $\frac{5}{8} \times 1\frac{3}{4}$	1
4	HB-12-13-500	Bolt $\frac{1}{2}$ - 13 x 5	4
	HNTL-12-13	Lock Nut $\frac{1}{2}$ - 13	4
5	HCP-12-200	Clevis Pin $\frac{1}{2}$ - 2	2
6	18-154	Rod End (part of machine)	1
7	42-217	Cylinder Mount (part of machine)	1

INSTALLATION INSTRUCTIONS

1. Assemble the Scarifier as shown on previous page.
2. Remove the rod end (Ref 6) on the hydraulic cylinder (Ref 2) from the cylinder mount (Ref 7). Remove the cylinder mount (Ref 7) from the machine.
- *3. Place the handle and linkage onto the empty linkage port of the two bank valve on the machine.
4. Slide the Scarifier under the machine lining up the hydraulic cylinder and the center of the attachment lift assembly.
5. Extend hydraulic cylinder all the way down by pushing the lever forward.
6. Mount the rod end of the cylinder onto the attachment lift assembly and secure with a clevis pin and bridge pin.
7. Attach the arms on the attachment lift to the attachment mount on the machine and secure with clevis pin and bridge pin.
8. Turn machine on and test for proper operation.
9. Adjust castor wheels by placing the short or long spacer on the castor wheel fork before placing the castor wheel assembly into the castor wheel brackets. Be sure both castor wheels are adjusted to the same height.

* For machines prior to serial numbers 4500 (3WD) and 12500 (2WD).

42-285 SCARIFIER WITH VERTICAL BLADES

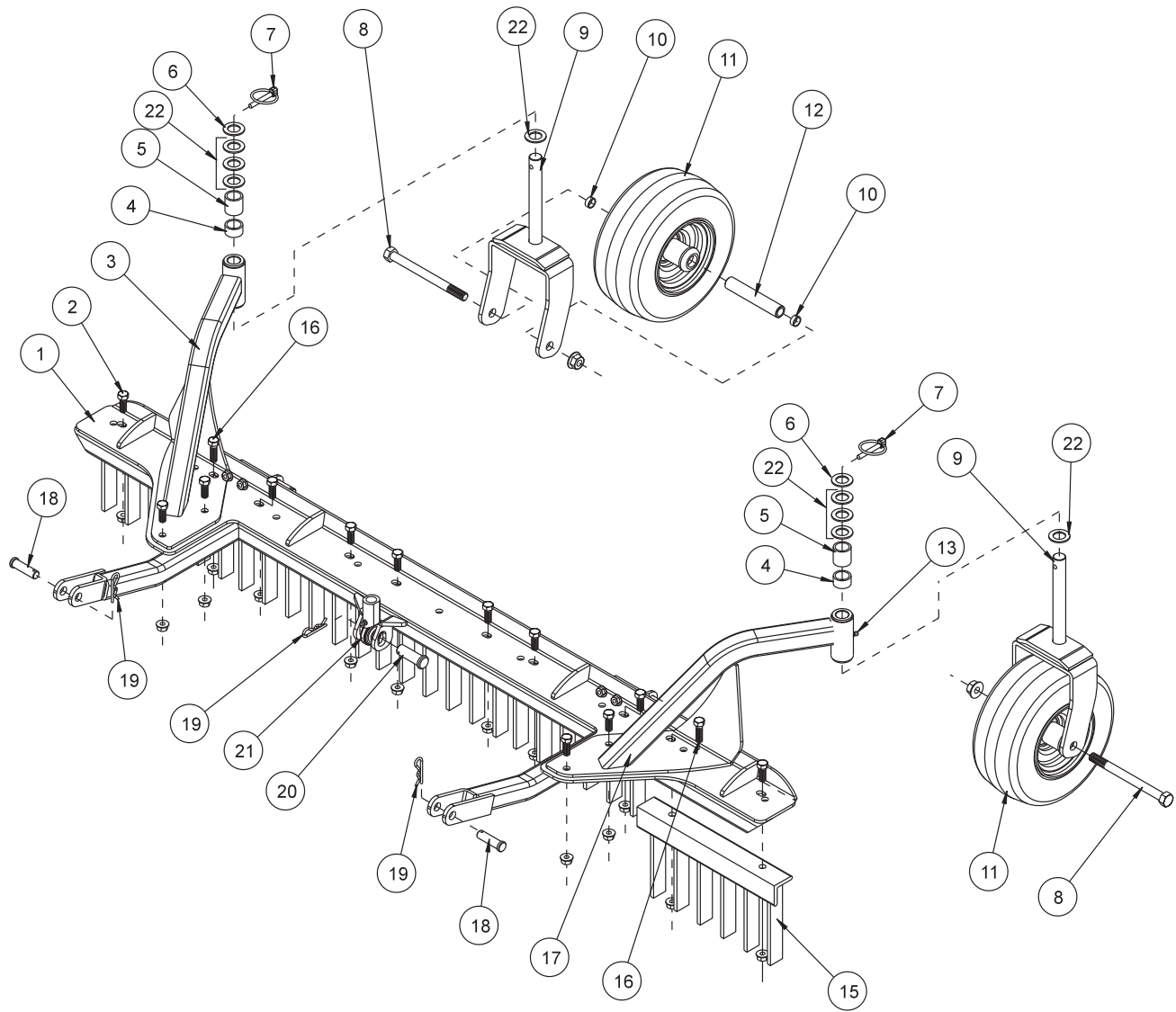

Accessories

42-285 SCARIFIER WITH VERTICAL BLADES PARTS LIST

REF#	PART#	DESCRIPTION	QUANTITY
1	42-203	Attachment Lift Assembly	1
2	HB-38-16-100	Bolt $\frac{3}{8}$ - 16 x 1	12
	HNTL-38-16	Lock Nut $\frac{3}{8}$ - 16	12
3	42-288	Left Castor Wheel Bracket	1
	10-025	Bushing (part of 42-288)	2
4	42-215	Short Spacer	2
5	42-214	Long Spacer	2
6	HMB-34-14	Machine Bushing $\frac{3}{4}$ x 14GA	2
7	42-539	Lynch Pin $\frac{5}{16}$	2
8	HB-12-13-600	Bolt $\frac{1}{2}$ -13 x 6	2
	HNTL-12-13	Lock Nut $\frac{1}{2}$ - 13	2
9	42-204	Castor Fork	2
10	42-212	Castor Wheel Spacer	4
11	42-202	Tire and Wheel	2
	42-202-01	Tire 9 x 3.5 x 4 Ply	2
	42-202-02	Wheel	2
	42-202-03	Cap	4
	42-202-04	Bearing	4
	42-202-05	Seal	4
12	42-213	Axle Bearing	2
13	HG-14-28-180	Grease Fitting $\frac{1}{4}$ - 28 x 180° (part of 42-288 and 42-289)	2
15	42-241	Tine Segment	5
16	HB-38-16-125	Bolt $\frac{3}{8}$ - 16 x $1\frac{1}{4}$	2
	HNTL-38-16	Lock Nut $\frac{3}{8}$ - 16	2
17	42-289	Right Castor Wheel Bracket	1
	10-025	Bushing (part of 42-289)	2
18	HCP-12-175	Clevis Pin $\frac{1}{2}$ x $1\frac{3}{4}$	2
19	HHP-18	Bridge Pin $\frac{1}{8}$	3
20	HCP-58-250	Clevis Pin $\frac{5}{8}$ x $2\frac{1}{2}$	1
21	18-154	Rod End (part of machine)	1
22	HMB-34-10	Machine Bushing $\frac{3}{4}$ x 10GA	8

42-285 SCARIFIER WITH VERTICAL BLADES MOUNTING DRAWING

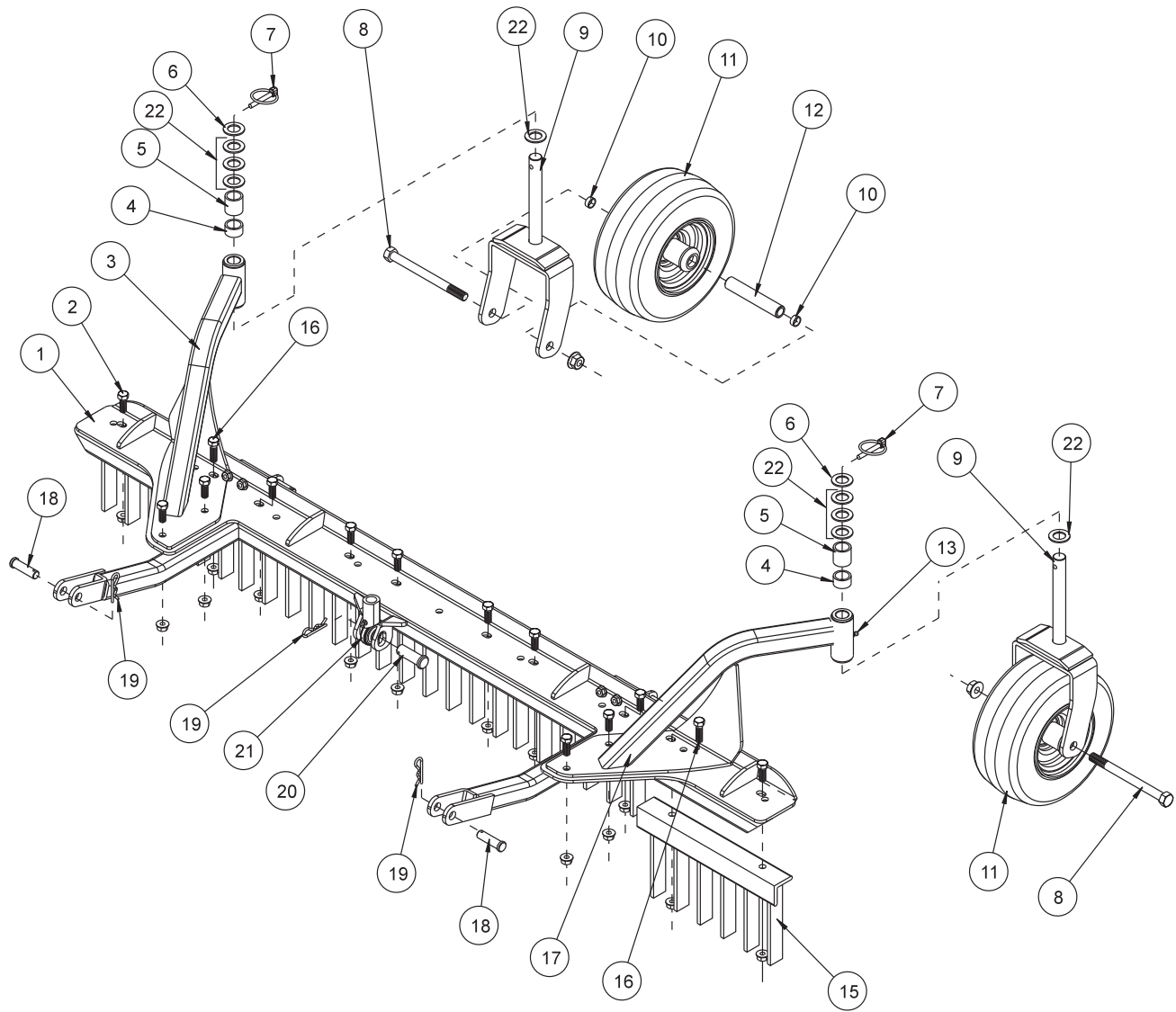

Accessories

42-285 SCARIFIER WITH VERTICAL BLADES MOUNTING PARTS LIST

REF#	PART#	DESCRIPTION	QUANTITY
1	HHP-18	Bridge Pin $\frac{1}{8}$	3
2		Hydraulic Cylinder (part of machine)	1
3	HCP-58-175	Clevis Pin $\frac{5}{8} \times 1\frac{3}{4}$	1
4	HB-12-13-500	Bolt $\frac{1}{2}$ - 13 x 5 (part of machine)	4
	HNTL-12-13	Lock Nut $\frac{1}{2}$ - 13 (part of machine)	4
5	HCP-12-175	Clevis Pin $\frac{1}{2}$ - $1\frac{3}{4}$	2
6	18-154	Rod End (part of machine)	1
7	42-217	Cylinder Mount (temporary part of machine)	1

INSTALLATION INSTRUCTIONS

1. Assemble the Scarifier as shown on previous page.
2. Disconnect the rod end (Ref 6) on the hydraulic cylinder (Ref 2) from the cylinder mount (Ref 7). Remove the cylinder mount (Ref 7) from the machine.
3. Place the handle and linkage onto the empty linkage port of the two bank valve on the machine.
4. Slide the Scarifier under the machine lining up the hydraulic cylinder and the center of the attachment lift assembly.
5. Extend hydraulic cylinder all the way down by pushing the lever forward.
6. Mount the rod end of the cylinder onto the attachment lift assembly and secure with a clevis pin and bridge pin.
7. Attach the arms on the attachment lift to the attachment mount on the machine and secure with clevis pin and bridge pin.
8. Turn machine on and test for proper operation.
9. Adjust castor wheels by placing the short or long spacer on the castor wheel fork before placing the castor wheel assembly into the castor wheel brackets. Be sure both castor wheels are adjusted to the same height.

42-026 84"(213CM) STAINLESS STEEL TOURNAMENT RAKE DRAWING

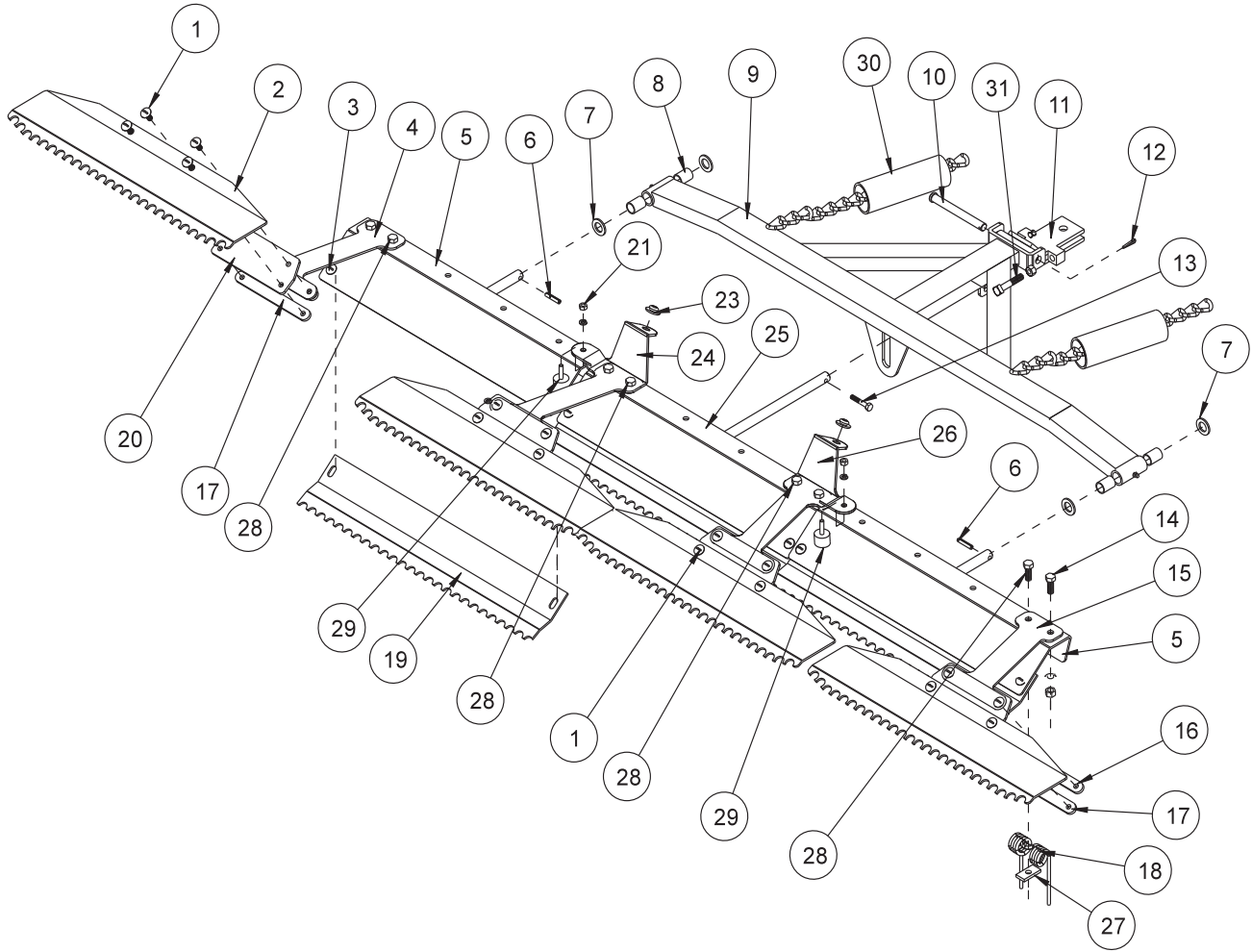

Accessories

42-026 84" (213CM) STAINLESS STEEL TOURNAMENT RAKE PARTS LIST

REF#	PART#	DESCRIPTION	QUANTITY
1	HSTS-516-18-100	Stainless Truss Head Screw $5/16$ - 18 x 1	16
	HWL-516	Lockwasher $5/16$	16
	HN-516-18	Nut $5/16$ - 18	16
2	42-104	Finishing Blades	4
3	HSTS-516-18-100	Stainless Truss Head Screw $5/16$ - 18 x 1	6
	HW-516	Washer $5/16$	6
	HWL-516	Lockwasher $5/16$	6
	HN-516-18	Nut $5/16$ - 18	6
4	42-111	Left Outside Mount	1
5	42-102	Outside Rake	2
6	HRP-14-100	Roll Pin $1/4$ x 1	2
7	HMB-58-14	Machine Bushing $5/8$ x 14GA	4
8	20-018	Oilite Bushing (comes with drawbar)	4
9	42-100	Draw Bar	1
	25-338	Decal, Speed Boss	1
10	HCP-12-450	Clevis Pin $1/2$ x $4 1/2$	1
11	13-647	Hitch	1
	HCP-12-150	Clevis Pin $1/2$ x $1 1/2$	1
	HHP-18	Bridge Pin $1/8$	1
12	HP-18-100	Cotter Pin $1/8$ x 1	1
13	HB-14-20-175	Bolt $1/4$ - 20 x $1 3/4$	1
	HNTL-14-20	Lock Nut $1/4$ - 20	1
14	HSTPS-516-18-125	Stainless Steel Phillips Truss Head Screw $5/16$ - 18 x $1 1/4$	4
	HWL-516	Lockwasher $5/16$	4
	HN-516 -18	Nut $5/16$ - 18	4
15	42-109	Right Outside Mount	1
16	42-105	Top Strap	4
17	42-106	Bottom Strap	4
18	42-122	Rake Spring	12
19	42-103	Groomer Blades	3
20	42-107	Matting	4
21	HNC-14-20	Cap Nut $1/4$ - 20	2
	HWL-14	Lockwasher $1/4$	2
23	42-116	Rubber insert	2
24	42-110	Left Inside Mount	1
25	42-101	Center Rake	1
26	42-108	Right Inside Mount	1
27	42-177	Spring Holder	12
28	HSTPS-516-18-125	Stainless Steel Phillips Truss Head Screw $5/16$ - 18 x $1 1/4$	12
	HWL-516	Lockwasher $5/16$	12
	HN-516 - 18	Nut $5/16$ - 18	12
29	15-013	Rubber Bumper	2
30	8892-6	Hose Wrap $1/4$ "	2
31	HSSQ-38-16-200	Square Head Set Screw $3/8$ - 16 x 2 (comes with 13-647)	2
	HN-38-16	Nut $3/8$ - 16 (comes with 13-647)	2

42-026 84"(213CM) STAINLESS STEEL TOURNAMENT RAKE DRAWING

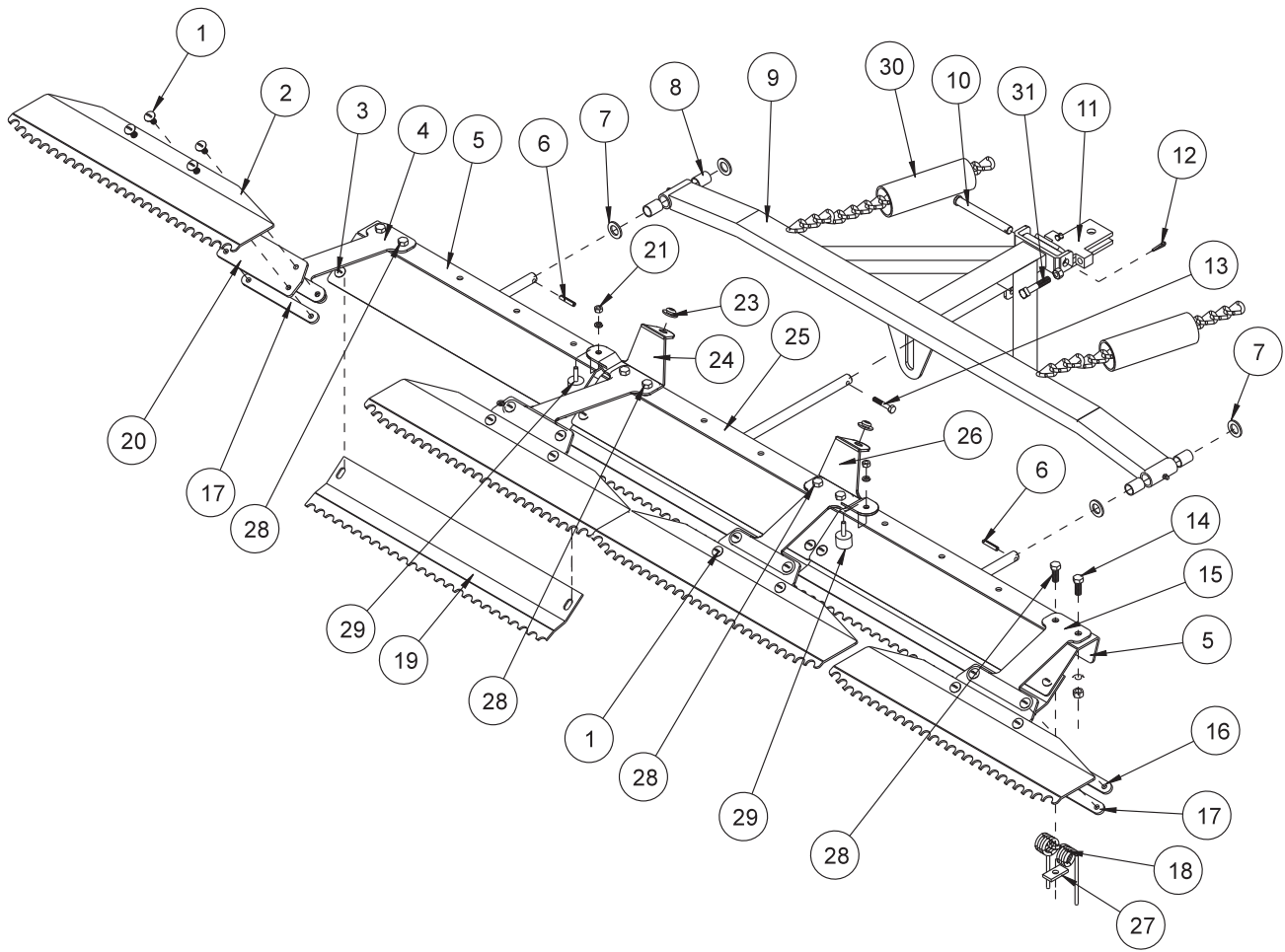

Accessories

INSTALLATION INSTRUCTIONS

1. Attach drawbar (Ref 9) to hitch (Ref 11) using clevis pin (Ref 10) and cotter pin (Ref 12).
 2. Attach rubber bumper (Ref 29) using cap nut and lock washer (Ref 21). Attach the rubber inserts (Ref 23) to the inside mounts (Ref 24 and 26).
 3. Attach the left outside mount (Ref 4), the left inside mount (Ref 24), the outside trowel mount (Ref 15), and the inside trowel mount (Ref 26) to the outside and center rakes (Ref 5 and 25) as shown. Use the 1¹/₄" stainless steel truss head screws (Ref 14) on the outside hole of each rake.
 4. Use the spring holder (Ref 27) and the 1¹/₄" stainless steel truss head screws (Ref 28) to attach rake springs (Ref 18) to the rakes.
 5. Slide a machine bushing onto outside rake frames then slide the outside rake frames (Ref 5) into the tubing on the end of the drawbar. Hold in place with another machine bushing and a roll pin (Ref 6).
 6. Attach center rake (Ref 25) to draw bar (Ref 9) as shown, using the 1¹/₄ - 20 - 1³/₄ bolt and lock nut (Ref 13) with the shaft of the center rake between the tabs on the bottom of the drawbar.
 7. Attach the matting (Ref 20) and the top strap (Ref 16) to the inside and outside mounts using stainless steel truss head screw ⁵/₁₆ - 18 x 1 (Ref 1). Attach four finishing blades (Ref 2) to the matting on the inside and outside mounts with the stainless steel truss head screw ⁵/₁₆ - 18 x 1 (Ref 1) going through the finishing blade, matting, and bottom strap (Ref 17).
 8. Place the three groomer blades (Ref 19) under the three rake assemblies as shown, using (Ref 3).
 9. Attach the rake hitch (Ref 11) to the trap rake hitch.
 10. The end links of chain on the drawbar are to be hooked to the hooks of the trap rake lift.
 11. With the rake on the ground pull the rake to the right side until it is 2-3 inches from the tire.
 12. Using the adjustment screw (Ref 31) on the right side of hitch, adjust the screw until it hits the trap rake hitch, located on rear axle. Lock nut so adjustment will not change.
 13. Repeat steps 8 and 9 on left side.
 14. Turn machine on and test for operation of rake assembly by raising and lowering the rake assembly. Also with rake down, turn sharp corners to check that rake does not touch wheels.
- NOTE:** Test rake in sand to assure tire tracks are covered by the rake when turning sharp corners in either direction. If there are tire tracks, readjust using the adjusting screws on the hitch, so the rake comes closer to the tire.

42-128 72" (183 CM) STAINLESS STEEL TOURNAMENT RAKE DRAWING

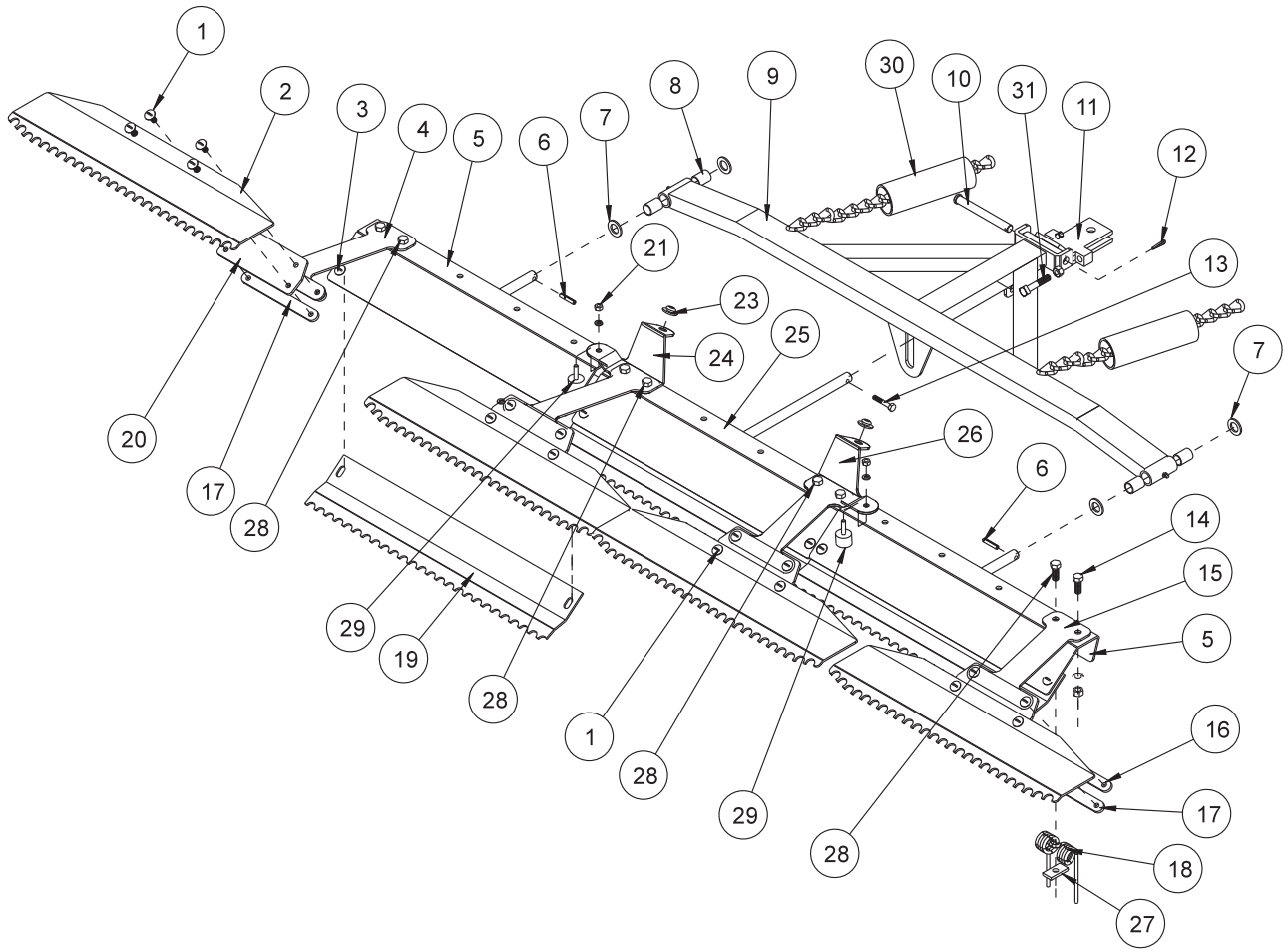

Accessories

42-128 72" (183 CM) STAINLESS STEEL TOURNAMENT RAKE PARTS LIST

REF#	PART#	DESCRIPTION	QUANTITY
1	HSTS-516-18-100	Stainless Steel Truss Head Screw $5/16$ - 18 x 1	16
	HWL-516	Lock Washer $5/16$	16
	HN-516-18	Nut $5/16$ - 18	16
2	42-137	Finishing Blades	4
3	HSTS-516-18-100	Stainless Steel Truss Head Screw $5/16$ - 18 x 1	6
	HW-516	Washer $5/16$	6
	HWL-516	Lock Washer $5/16$	6
	HN-516-18	Nut $5/16$ - 18	6
4	42-111	Left Outside Mount	1
5	42-140	Outside Rake	2
6	HRP-14-100	Roll Pin $1/4$ x 1	2
7	HMB-58-14	Machine Bushing $5/8$ x 14GA	4
8	20-018	Oilite Bushing (comes with 42-141)	4
9	42-141	Draw Bar	1
10	HCP-12-450	Clevis Pin $1/2$ x $4 1/2$	1
11	13-647	Hitch	1
	HCP-12-150	Clevis Pin $1/2$ x $1 1/2$	1
	HHP-18	Bridge Pin $1/8$	1
12	HP-18-100	Cotter Pin $1/8$ x 1	1
13	HB-14-20-175	Bolt $1/4$ - 20 x $1 3/4$	1
	HNTL-14-20	Lock Nut $1/4$ - 20	1
14	HSTPS-516-18-125	Stainless Steel Phillips Truss Head Screw $5/16$ - 18 x $1 1/4$	4
	HWL-516	Lock Washer $5/16$	4
	HN-516-18	Nut $5/16$ - 18	4
15	42-109	Outside Trowel Mount	1
16	42-105	Top Strap	4
17	42-106	Bottom Strap	4
18	42-122	Rake Spring	12
19	42-138	Groomer Blades	3
20	42-107	Matting	4
21	HNC-14-20	Cap Nut $1/4$ - 20	2
	HWL-14	Lock Washer $1/4$	2
23	42-116	Rubber Insert	2
24	42-110	Left Inside Mount	1
25	42-139	Center Rake	1
26	42-108	Inside Trowel Mount	1
27	42-177	Spring Holder	12
28	HSTPS-516-18-125	Stainless Steel Phillips Truss Head Screw $5/16$ - 18 x $1 1/4$	12
	HWL-516	Lock Washer $5/16$	12
	HN-516-18	Nut $5/16$ - 18	12
29	15-013	Rubber Bumper	2
30	8892-6	Hose Wrap	2
31	HSSQ-38-16-200	Square Head Set Screw $3/8$ - 16 x 2 (comes with 13-647)	2
	HN-38-16	Nut $3/8$ - 16 (comes with 13-647)	2

42-128 72" (183 CM) STAINLESS STEEL TOURNAMENT RAKE DRAWING

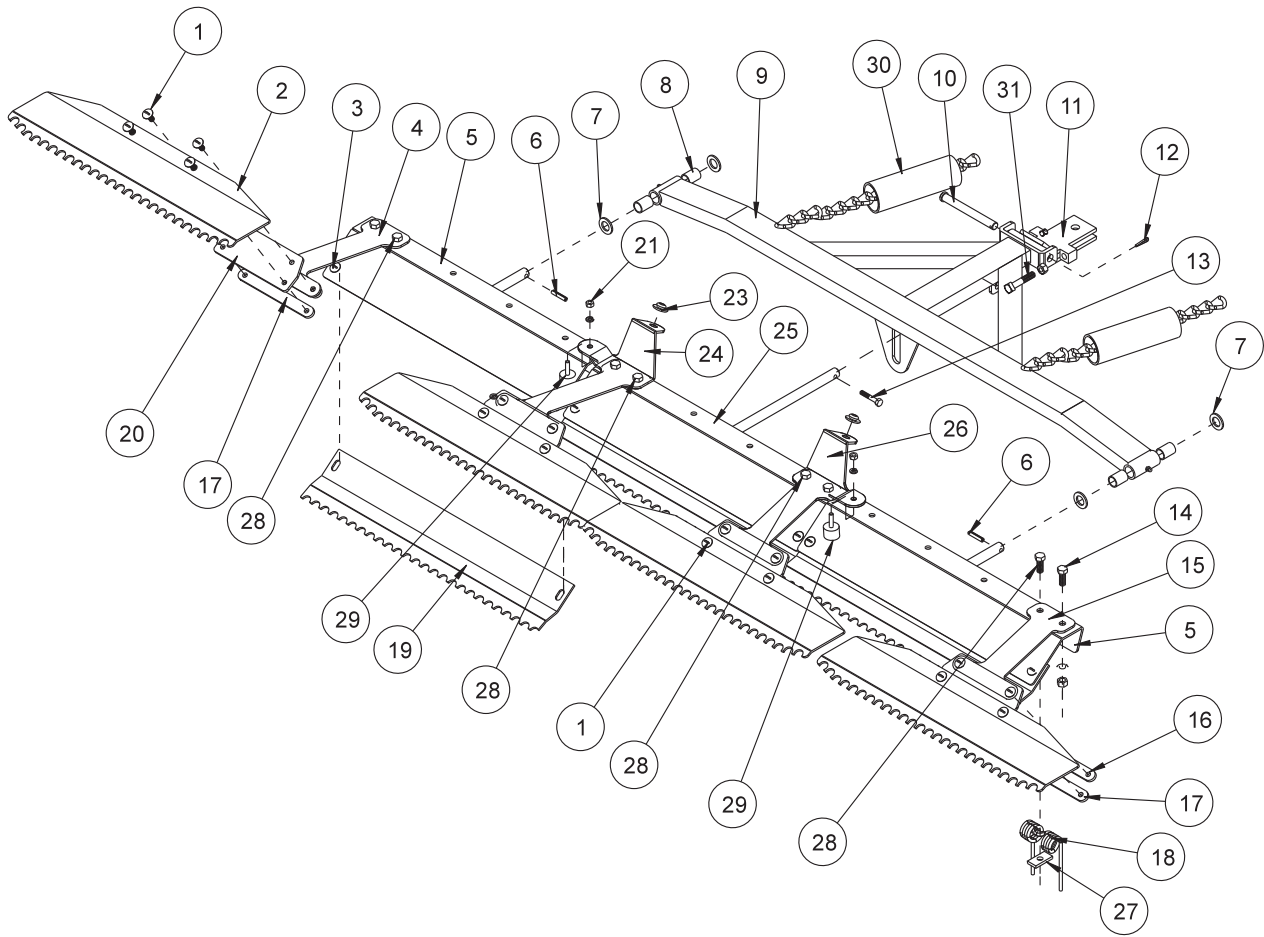

Accessories

INSTALLATION INSTRUCTIONS

1. Attach drawbar (Ref 9) to hitch (Ref 11) using clevis pin (Ref 10) and cotter pin (Ref 12).
 2. Attach rubber bumper (Ref 29) using cap nut and lock washer (Ref 21). Attach the rubber inserts (Ref 23) to the inside mounts (Ref 24 and 26).
 3. Attach the left outside mount (Ref 4), the left inside mount (Ref 24), the outside trowel mount (Ref 15), and the inside trowel mount (Ref 26) to the outside and center rakes (Ref 5 and 25) as shown. Use the 1¹/₄" stainless steel truss head screws (Ref 14) on the outside hole of each rake.
 4. Use the spring holder (Ref 27) and the 1¹/₄" stainless steel truss head screws (Ref 28) to attach rake springs (Ref 18) to the rakes.
 5. Slide a machine bushing onto outside rake frames then slide the outside rake frames (Ref 5) into the tubing on the end of the drawbar. Hold in place with another machine bushing and a roll pin (Ref 6).
 6. Attach center rake (Ref 25) to draw bar (Ref 9) as shown, using the 1¹/₄ - 20 - 1³/₄ bolt and lock nut (Ref 13) with the shaft of the center rake between the tabs on the bottom of the drawbar.
 7. Attach the matting (Ref 20) and the top strap (Ref 16) to the inside and outside mounts using stainless steel truss head screw ⁵/₁₆ - 18 x 1 (Ref 1). Attach four finishing blades (Ref 2) to the matting on the inside and outside mounts with the stainless steel truss head screw ⁵/₁₆ - 18 x 1 (Ref 1) going through the finishing blade, matting, and bottom strap (Ref 17).
 8. Place the three groomer blades (Ref 19) under the three rake assemblies as shown, using (Ref 3).
 9. Attach the rake hitch (Ref 11) to the trap rake hitch.
 10. The end links of chain on the drawbar are to be hooked to the hooks of the trap rake lift.
 11. With the rake on the ground pull the rake to the right side until it is 2-3 inches from the tire.
 12. Using the adjustment screw (Ref 31) on the right side of hitch, adjust the screw until it hits the trap rake hitch, located on rear axle. Lock nut so adjustment will not change.
 13. Repeat steps 8 and 9 on left side.
 14. Turn machine on and test for operation of rake assembly by raising and lowering the rake assembly. Also with rake down, turn sharp corners to check that rake does not touch wheels.
- NOTE:** Test rake in sand to assure tire tracks are covered by the rake when turning sharp corners in either direction. If there are tire tracks, readjust using the adjusting screws on the hitch, so the rake comes closer to the tire.

13-438 RAKE ASSEMBLY WITH FINISHING BLADES DRAWING

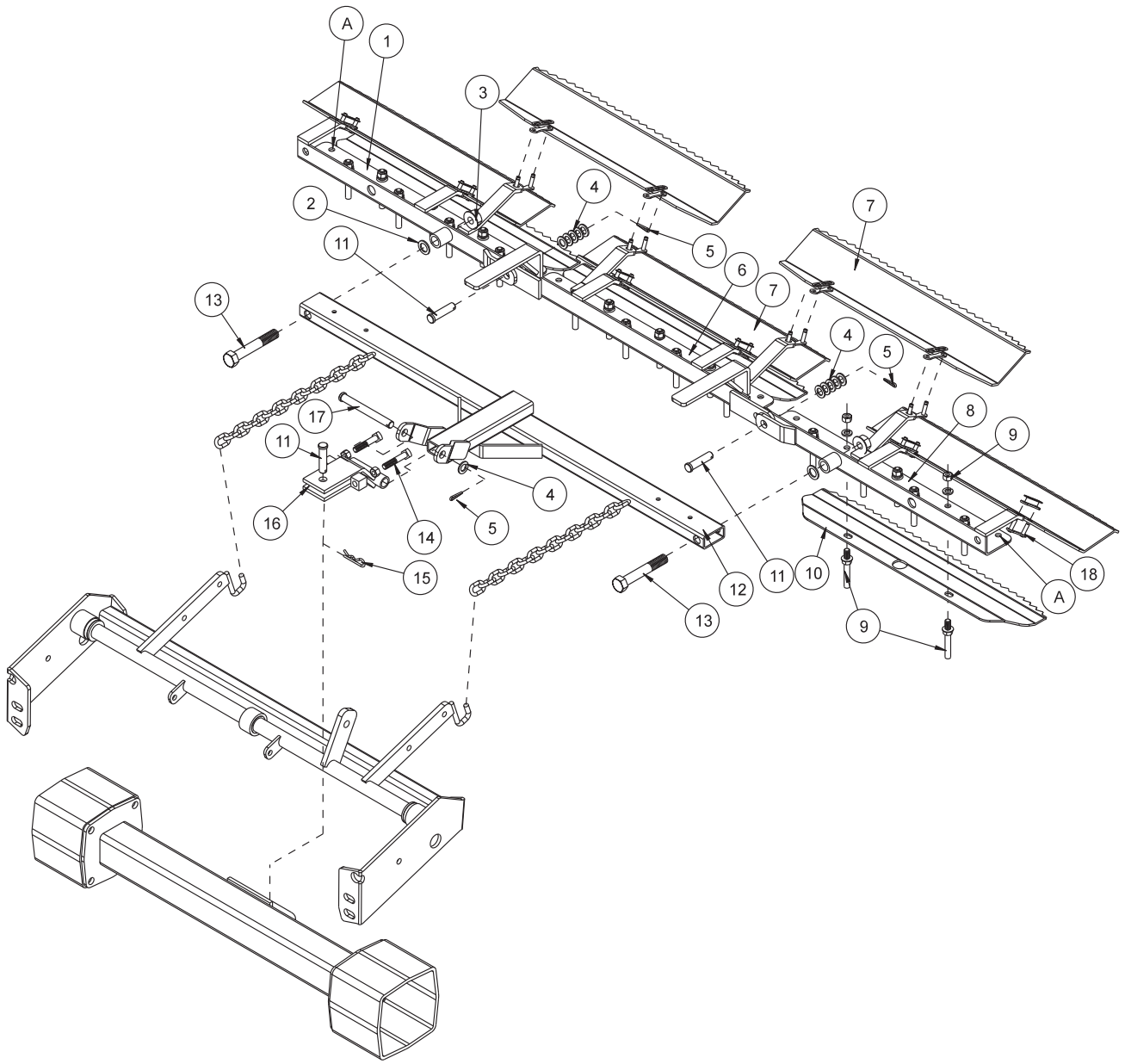

Accessories

13-438 RAKE ASSEMBLY WITH FINISHING BLADES PARTS LIST

REF#	PART#	DESCRIPTION	QUANTITY
1	13-441	Right Rake	1
2	HMB-58-14	Machine Bushing $\frac{5}{8}$ x 14GA	2
3	HNCL-58-11	Lock Nut $\frac{5}{8}$ - 11	2
4	HMB-12-14	Machine Bushing $\frac{1}{2}$ x 14GA	11
5	HP-18-100	Cotter Pin $\frac{1}{8}$ x 1	3
6	13-440	Center Rake	1
7	13-443	Finishing Blade	5
8	13-439	Left Rake	1
9*		Rake teeth	
10	13-442	Groomer Blade	3
11	HCP-12-150	Clevis Pin $\frac{1}{2}$ - $1\frac{1}{2}$	3
12	13-365	Drawbar	1
13	HB-58-11-400	Bolt $\frac{5}{8}$ - 11 x 4	2
14	HSSQS-38-16-200	SS Square Head Set Screw $\frac{3}{8}$ -16 x 2 (comes with 13-647)	2
	HN-38-16	Nut $\frac{3}{8}$ - 16 (comes with 13-647)	2
15	HHP-18	Bridge Pin $\frac{1}{8}$	1
16	13-647	Hitch (includes Ref 14)	1
17	HCP-12-450	Clevis Pin $\frac{1}{2}$ - $4\frac{1}{2}$	1
18	13-417	Connector Link	10
*	13-090	Rake Teeth Kit (Studs and Hardware)	1

INSTALLATION INSTRUCTIONS

1. Attach drawbar (Ref 12) to hitch (Ref 16) using clevis pin, machine bushing and cotter pin (Ref 17, 4 and 5).
2. Bolt rake teeth (Ref 9) to frames, keeping all the same length. Leave the two outside holes on right and left rake open (Ref A).
3. Lay out rake frames (Ref 1,6 and 8). Connect them using clevis pin, machine bushing and cotter pin (Ref 11, 4 and 5).
4. Attach drawbar to left and right frames using bolt, machine bushing, and nut (Ref 13, 2 and 3).
5. Attach five finishing blades (Ref 7) to the tabs of the rake frames using master link (Ref 18). Blades may be mounted with saw tooth up or down, depending on the desired finish of the sand trap.
6. Attach the rake hitch (Ref 16) to trap rake hitch on the rear axle using a clevis pin and bridge pin (Ref 11 and 15).
7. The end links of chain on the drawbar are to be hooked to the hooks of the trap rake lift.
8. With the rake on the ground pull the rake to the right side until it is 2-3 inches from the tire.
9. Using the adjustment screw (Ref 14) on the right, adjust the screw until it hits the trap rake hitch, located on rear axle. Lock jam nut so adjustment will not change.
10. Repeat steps 8 and 9 on left side.
11. Turn machine on and test for operation of rake assembly by raising and lowering the rake assembly. Also with rake down, turn sharp corners to check that rake does not touch wheels.
12. **NOTE:** Test rake in sand to assure tire tracks are covered by the rake when turning sharp corners in either direction. If there are tire tracks, readjust using the adjusting screws on the hitch, so the rake comes closer to the tire.

GROOMER BLADES - GOLF COURSE USE ONLY.

1. Place the three groomer blades (Ref 10) under the three rake assemblies (Ref 1, 6 and 8) .
2. Center blades below rear most row of rake teeth. The blade is designed to miss the outside two "teeth" and fit around the center "tooth".
3. Remove the two "teeth" that line up with slots of each groomer blade. Move blade up and into position and reattach "teeth". Blade thickness should be accounted for by shortening the "teeth" an equal length.

13-684 SAND RAKE BRUSH KIT DRAWING

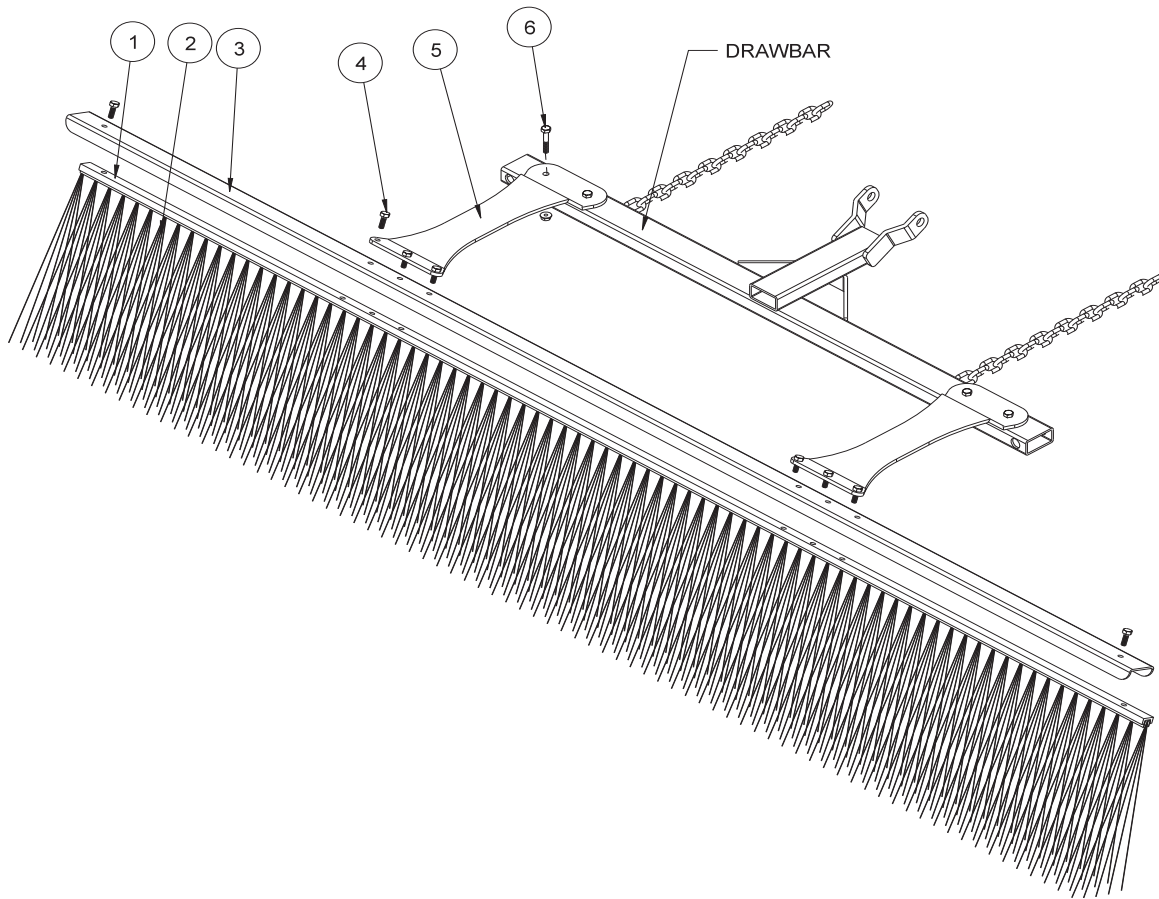

HOLE LOCATION

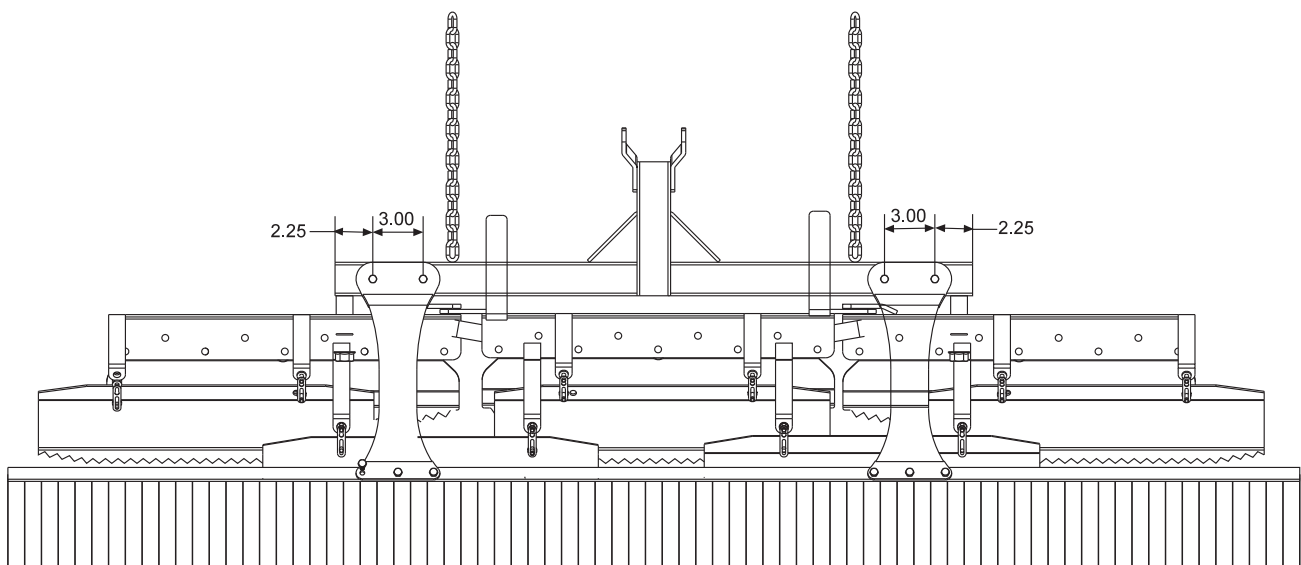

13-684 SAND RAKE BRUSH KIT PARTS LIST

REF#	PART#	DESCRIPTION	QUANTITY
1	13-683	Brush Track	1
2	13-682	Brush 77 x 11	1
3	13-688	Brush Channel	1
4	HB-14-20-075	Bolt $\frac{1}{4}$ - 20 x $\frac{3}{4}$	6
	HNFL-14-20	Flange Whiz-Lock Nut $\frac{1}{4}$ - 20	6
5	13-681	Mounting Brackets	2
6	HB-14-20-150	Bolt $\frac{1}{4}$ - 20 x $1\frac{1}{2}$	4
	HNFL-14-20	Flange Whiz-Lock Nuts $\frac{1}{4}$ - 20	4

INSTALLATION INSTRUCTIONS

1. Place the brush (Ref 2) into the brush track (Ref 1). Place the brush channel (Ref 3) between the brush track and the mounting brackets. Now bolt the mounting brackets (Ref 5) to the brush track using the $\frac{3}{4}$ " bolts and flange whiz-lock nuts (Ref 3).
2. Two holes need to be drilled into the drawbar of the rake to install the brush. Drill two .281 holes $2\frac{1}{4}$ " in from each end and 3" apart (see drawing).
3. Mount the brush assembly to the drawbar using four $\frac{3}{4}$ " bolts and flange whiz-lock nuts (Ref 5).

13-298 FAN RAKE ATTACHMENT DRAWING

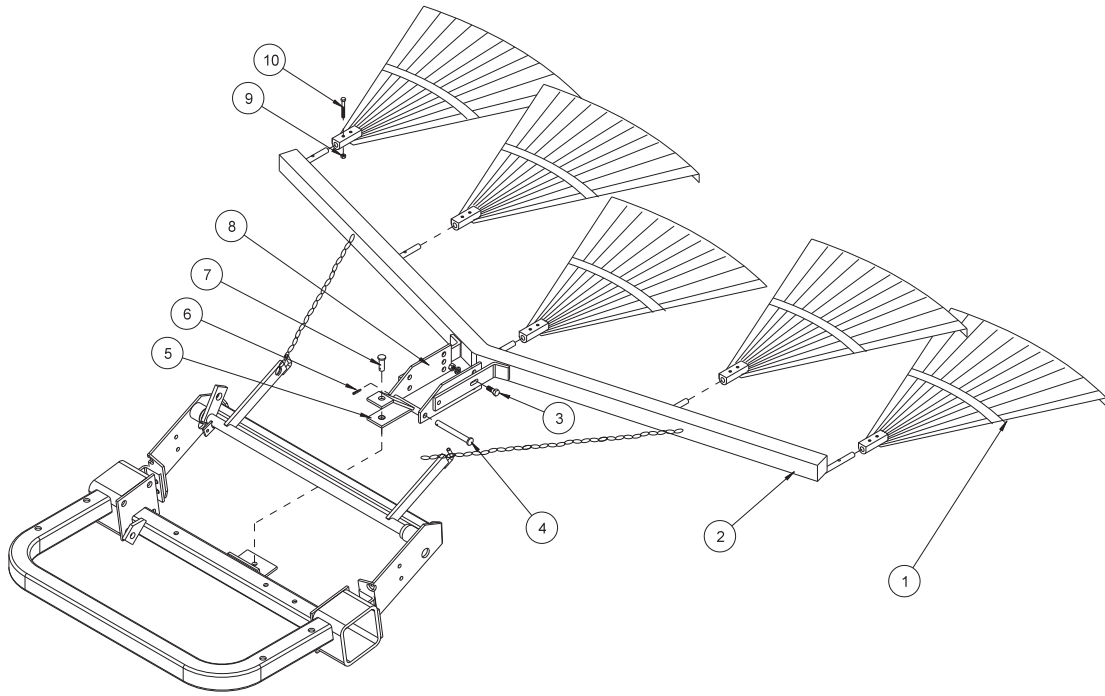

13-319 FAN RAKE KIT

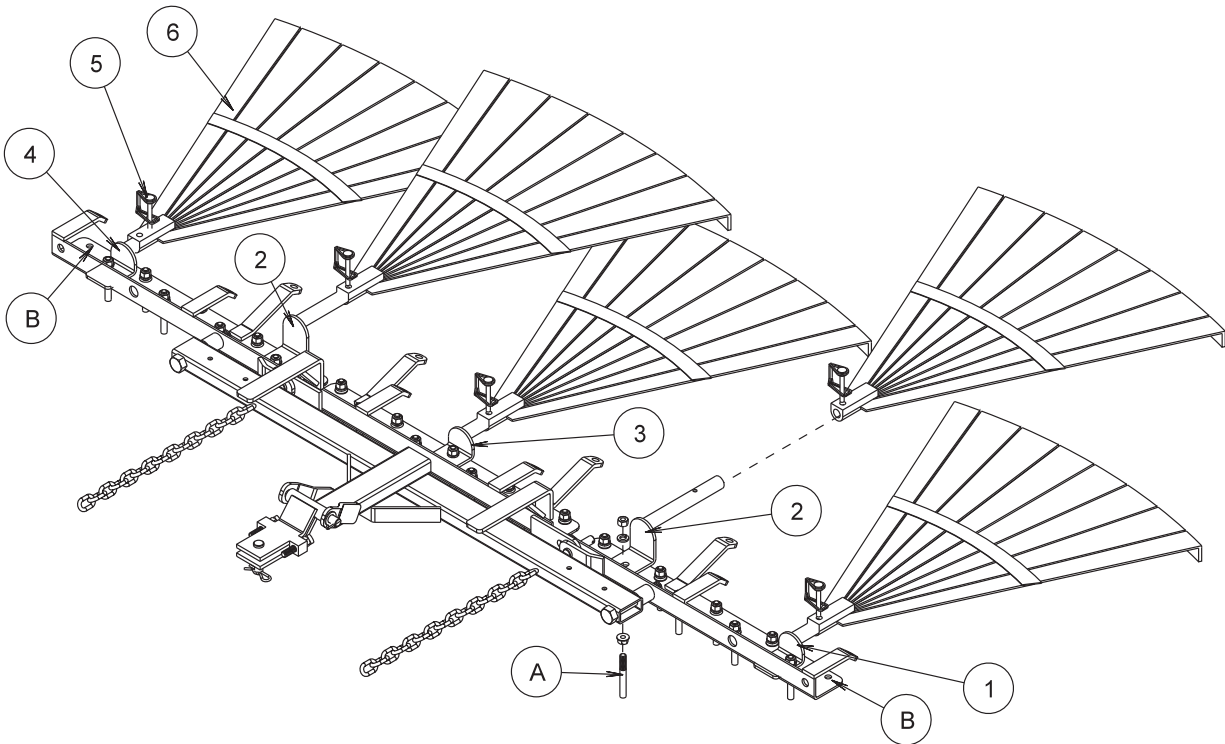

Accessories

13-298 FAN RAKE ATTACHMENT PARTS LIST

REF#	PART#	DESCRIPTION	QUANTITY
1	13-310	Rake	5
2	13-306	Frame	1
3	HB-38-16-100	Bolt ³ / ₈ - 16 x 1	4
	HN-38-16	Nut ³ / ₈ - 16	4
	HWL-38	Lockwasher ³ / ₈	4
4	HCP-12-450	Clevis Pin 1/2 x 4 1/2	1
5	19-107	Drawbar	1
6	HP-18-100	Cotter Pin 1/8 x 1	1
7	HCP-12-150	Clevis Pin 1/2 x 1 1/2	1
	HHP-18	Bridge Pin 1/8	1
8	13-307	Hitch	2
9	HNCL-14-20	Center Lock Nut 1/4 - 20	5
10	HB-14-20-200	Bolt 1/4 - 20 x 2	5

INSTALLATION INSTRUCTIONS

1. Remove the complete rake assembly from the trap rake. Replace the clevis pin and bridge pin in the hitch for future use with the rake.
2. Assemble hitch (Ref 8) to frame (Ref 2) using hardware (Ref 3). Assemble drawbar (Ref 5) to the hitch using clevis pin (Ref 4) and cotter pin (Ref 6), as shown. The different holes in the hitch are for adjusting the angle of the rakes.
3. Assemble the five rakes (Ref 1) to the frame using the bolt and center lock nuts (Ref 9 and 10). Slide the fan rake assembly under the rear of the trap rake to the hitch. Attach the drawbar to the hitch using the clevis pin and the bridge pin (Ref 7).
4. Hook the chains from the frame to the hooks on the rake lift.

13-319 FAN RAKE KIT PARTS LIST

REF#	PART#	DESCRIPTION	QUANTITY
1	13-326	Left Holder	1
2	13-329	Long Holder	2
3	13-327	Center Holder	1
4	13-328	Right Holder	1
5	29-541	Lock Pin	5
6	13-310	Rake	5

FAN RAKE KIT INSTRUCTIONS

1. Remove connector links that hold rake blades to rake frame if desired.
2. Remove groomer blades from rake frame that are held on with rake teeth studs (Ref A). Replace rake teeth studs, if desired.
3. Place left holder (Ref 1), angle side up, to the second rake tooth hole from the end and install rake tooth stud. The first rake tooth hole from each end (Ref B) have no rake teeth in them.
4. Remove the 8th rake tooth stud from the end of right and left rake frame and place long holders (Ref 2) on top, reinstall rake teeth studs.
5. Remove rake tooth in direct center of rake and install the center holder (Ref 3). Reinstall rake teeth studs.
6. Place right holder (Ref 4), angle side up, to the second rake tooth hole from the end and install rake tooth stud. The first rake tooth hole from each end (Ref B) have no rake teeth in them.
7. Slide fan rake (Ref 6) onto holders and pin with lock pin (Ref 5).



26-007 PROFESSIONAL INFIELD FINISHER DRAWING

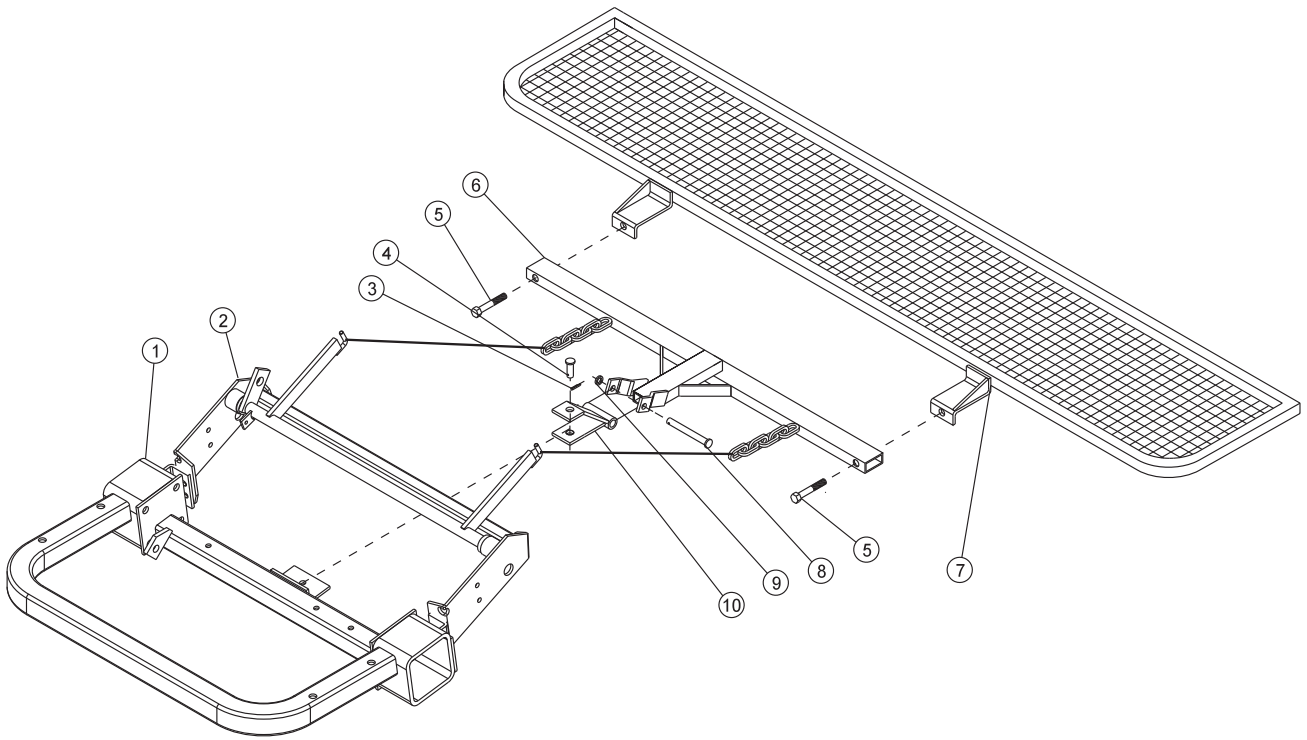

42-185 DRAG MAT KIT DRAWING

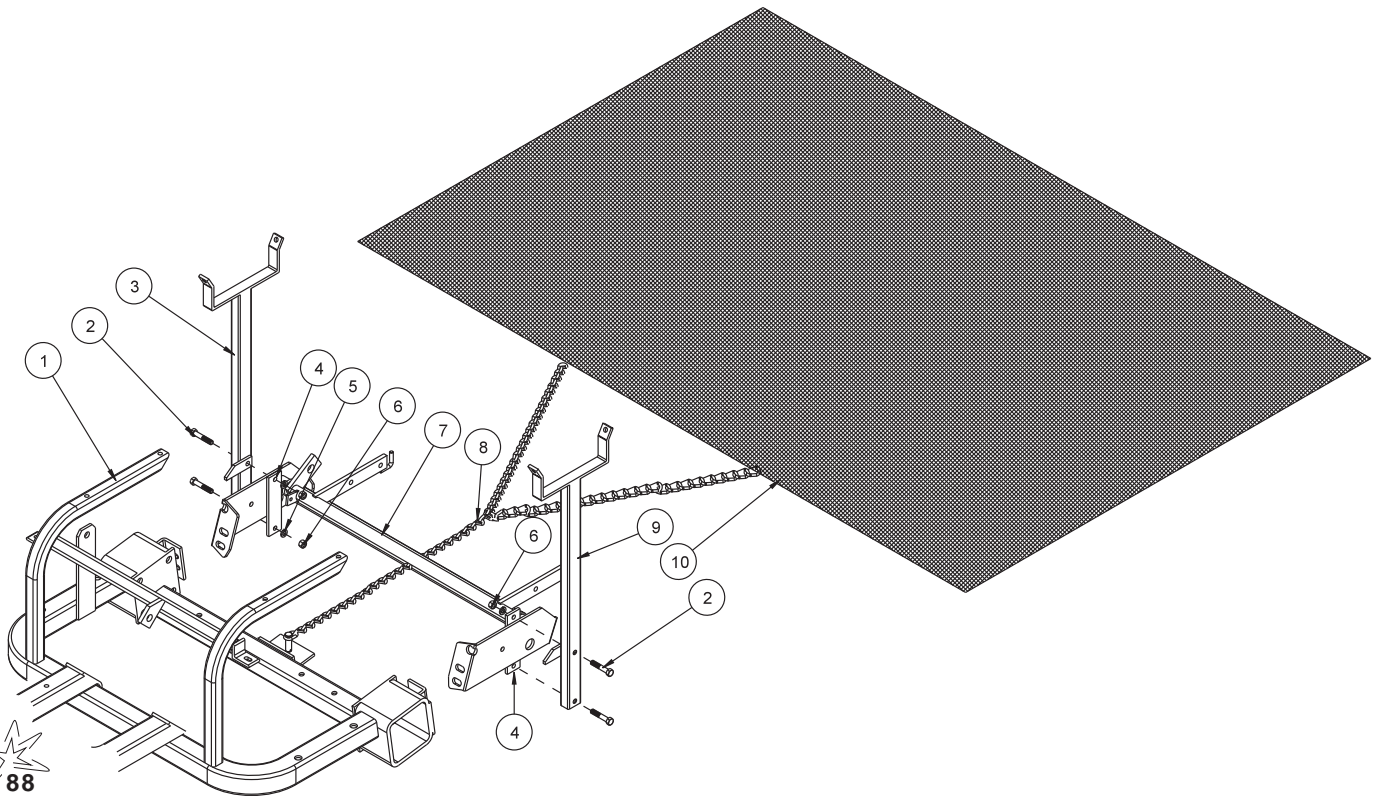

Accessories

26-007 PROFESSIONAL INFIELD FINISHER PARTS LIST

REF#	PART#	DESCRIPTION	QUANTITY
1		Rear Axle (part of main frame)	1
2	42-024	Rake Lift (part of machine)	1
3	HP-18-100	Cotter Pin $\frac{1}{8}$ x 1	1
4	HCP-12-150	Clevis Pin $\frac{1}{2}$ x $1\frac{1}{2}$	1
5	HB-58-11-300	Bolt $\frac{5}{8}$ - 11 x 3	2
	HNCL-58-11	Center Lock Nut $\frac{5}{8}$ - 11	2
6	13-365	Drawbar	1
7	26-045	Leveling Screen	1
8	HCP-12-450	Clevis Pin $\frac{1}{2}$ x $4\frac{1}{2}$	1
9	HMB-12-14	Machine Bushing $\frac{1}{2}$ x 14GA	1
10	19-107	Hitch	1
11	HHP-18	Bridge Pin $\frac{1}{8}$	1

INSTALLATION INSTRUCTIONS

The Professional Field Finisher is used for smoothing and leveling fields to professional standards.

1. Attach leveling screen (Ref 7) to drawbar (Ref 6) using two bolts (Ref 5) and center lock nuts.
2. Attach hitch (Ref 10) to drawbar (Ref 6) using clevis pin (Ref 8), machine bushing (Ref 9) and a cotter pin (Ref 3).
3. Mount Professional Field Finisher to the hitch on the trap rake with a clevis pin (Ref 4) and bridge pin (Ref 11).
4. Hook chains from finisher to rake lift arms.
5. **NOTE:** When assembled properly, rake will angle down from front to back. If front of finisher is not higher than the back, damage will result to infield.

42-185 DRAG MAT KIT PARTS LIST

REF#	PART#	DESCRIPTION	QUANTITY
1		Main Frame	1
2	HB-38-16-225	Bolt $\frac{3}{8}$ - 16 x $2\frac{1}{4}$	4
3	42-186	Right Mat Carrier	1
4	13-157	Strap	2
5	HWL-38	Lock Washer $\frac{3}{8}$	4
6	HN-38-16	Nut $\frac{3}{8}$ - 16	4
7	42-024	Rake Lift (part of machine)	1
8	19-605	Drag Mat Chain	1
	HHP-18	Bridge Pin $\frac{1}{8}$	1
9	42-187	Left Mat Carrier	1
10	19-601	Steel Mat	1

INSTALLATION INSTRUCTIONS

1. Looking from the rear of the Super Star, mount the mat carrier posts (Ref 3 & 9) outside the rear corner of the rake lift with the straps (Ref 4) on the inside of the rake lift side plate. Bolt into place with $\frac{3}{8}$ - 16 x $2\frac{1}{4}$ bolts, lockwasher and nuts.
2. To carry the Drag Mat, roll it up and place it in the brackets of the mat carriers.
3. To use the Drag Mat, unroll the mat flat and hook it up to the Super Star hitch with the clevis pin in the chain and the bridge pin provided.

43-002 FLEXACTION FIELD FINISHER WITH BRUSH DRAWING

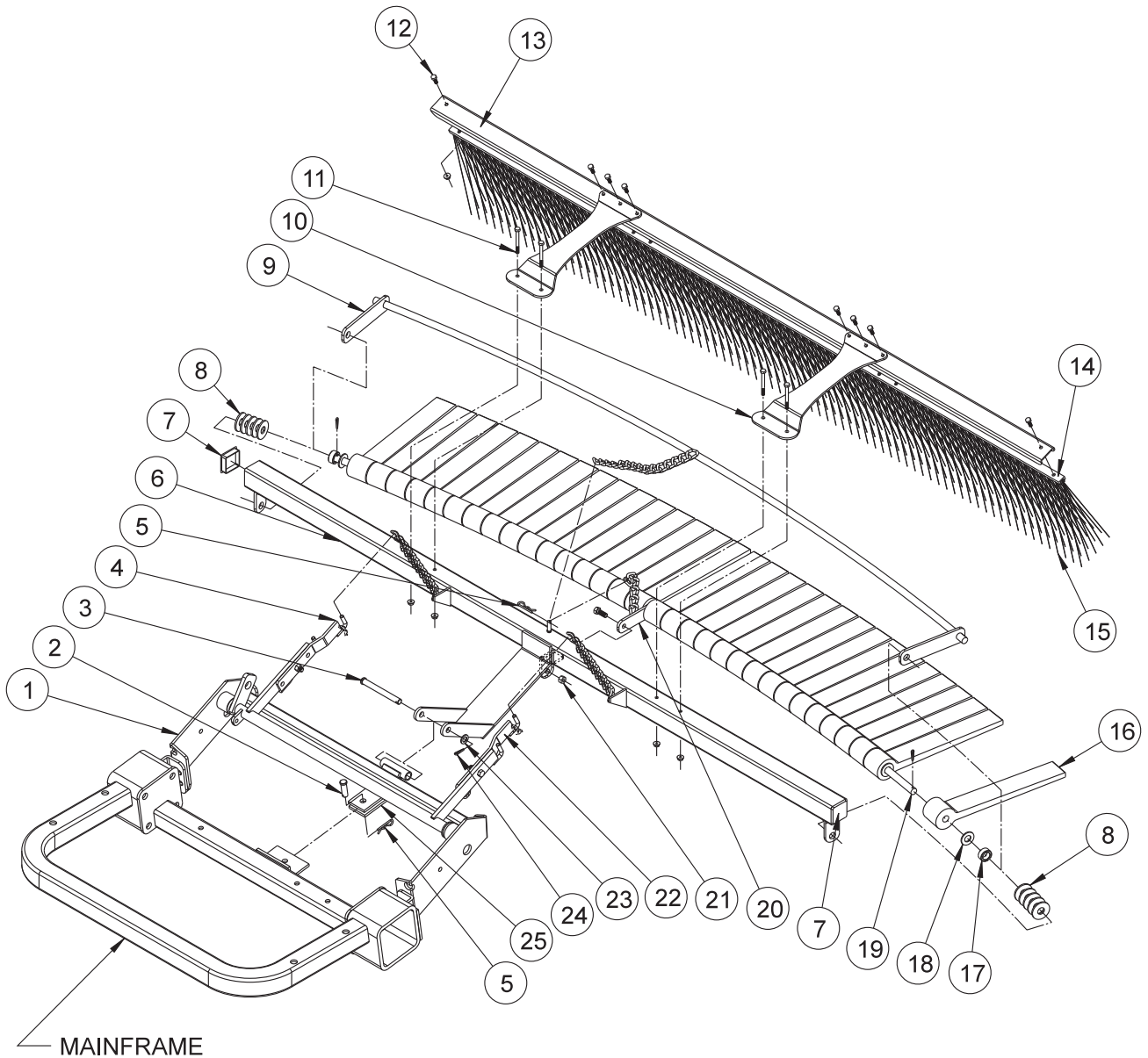

Accessories

43-002 FLEX ACTION FIELD FINISHER WITH BRUSH PARTS LIST

REF#	PART#	DESCRIPTION	QUANTITY
1		Rake Lift (comes with machine)	1
2	HCP-12-150	Clevis Pin $1/2$ x $1 1/2$	1
3	HCP-12-450	Clevis Pin, $1/2$ x $4 1/2$	1
4	26-116	Right Extension Arm	1
	HB-38-16-125	Bolt $3/8$ - 16 x $1 1/4$	1
	HNTL-38-16	Lock Nut $3/8$ - 16	1
5	HHP-18	Bridge Pin, $1/8$	2
6	26-046	Frame	1
7	18-297	Cap Plug	2
8	HMB-58-14	Machine Bushing $5/8$ x 14GA	10
9	26-047	Leveler Bar	1
10	43-041	Mount Bracket	2
11	HB-14-20-250	Bolt, $1/4$ -20 x $2 1/2$	4
	HNFL-14-20	Flange Whiz-Lock Nut, $1/4$ -20	4
12	HB-14-20-075	Bolt, $1/4$ -20 x $3/4$	8
	HNFL-14-20	Flange Whiz-Lock Nut, $1/4$ -20	8
13	13-688	Brush Channel	1
14	13-683	Brush Track	1
15	13-682	Brush, 77 x 11	1
16	26-041	Rasp Flail	32
17	11-040	Spacer, $3/4$ "	2
18	HW-58	Washer, $5/8$	32
19	26-049	Mounting Bar	1
	HP-18-100	Cotter Pin, $1/8$ x 1	2
20	26-048	Flail Bar Strap	1
21	HB-38-16-100	Bolt, $3/8$ - 16 x 1	1
	HNCL-38-16	Center Lock Nut, $3/8$ - 16	1
22	26-117	Left Extension Arm	1
	HB-38-16-125	Bolt $3/8$ - 16 x $1 1/4$	1
	HNTL-38-16	Lock Nut $3/8$ - 16	1
23	HMB-12-14	Machine Bushing, $1/2$ - 14GA	1
24	HP-18-100	Cotter Pin, $1/8$ x 1	1
25	19-107	Draw Bar Assembly	1

RAKE LIFT ARM HOLE PLACEMENT

If the Lift Arms on the Rake Lift are not drilled, use the following dimensions to drill $\varnothing 13/32$ holes to mount the extension arms to.

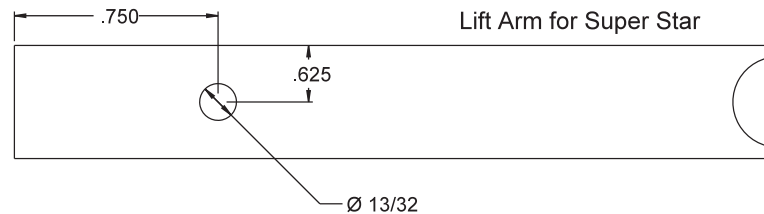
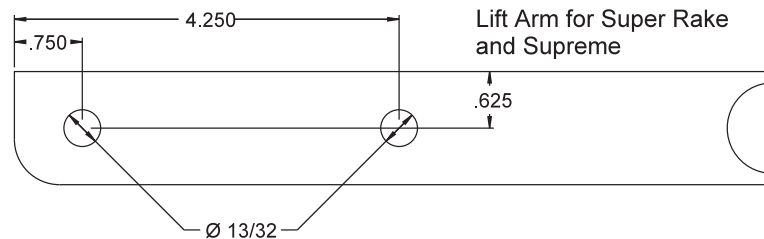

43-002 FLEXACTION FIELD FINISHER WITH BRUSH DRAWING

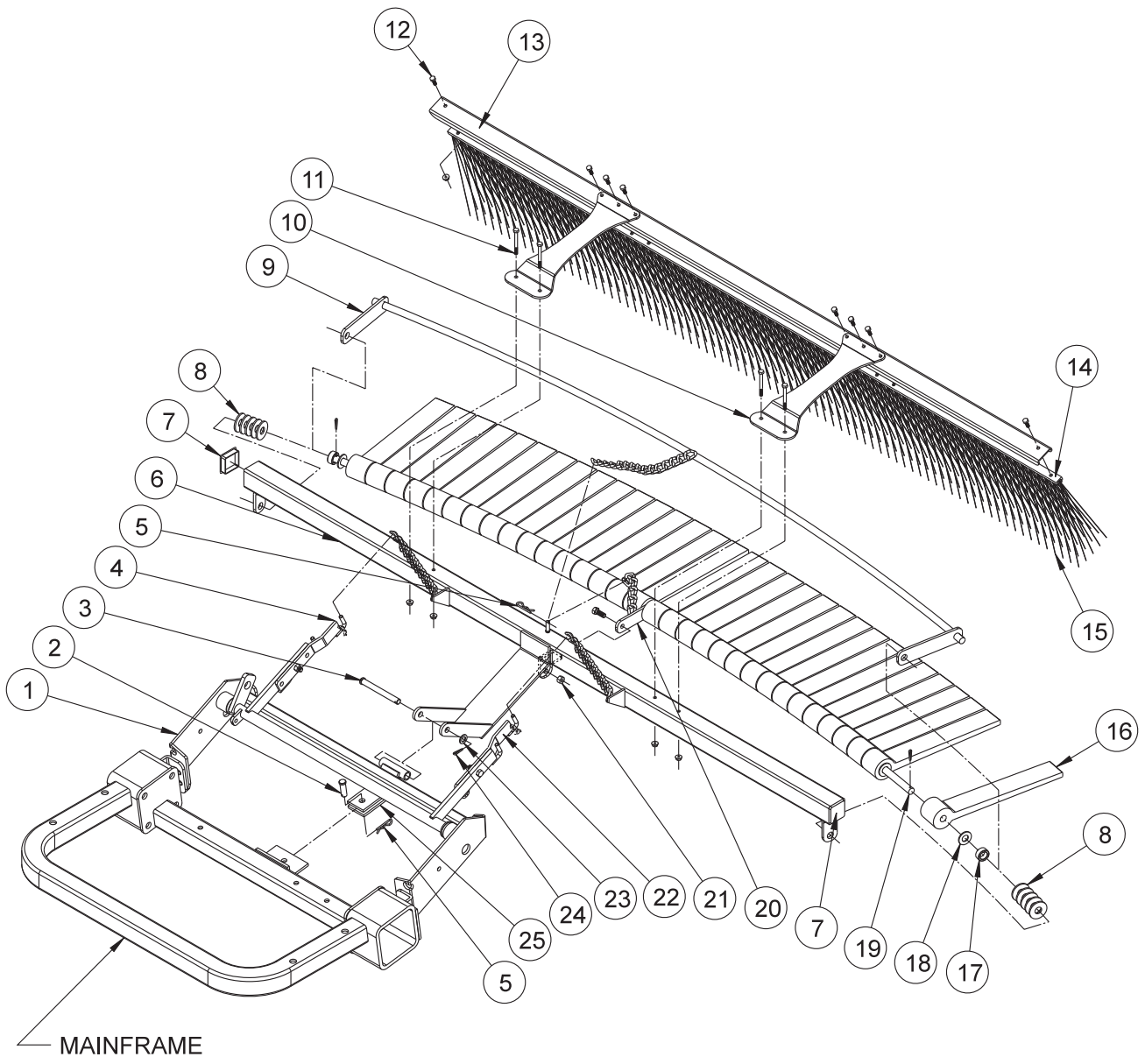

Accessories

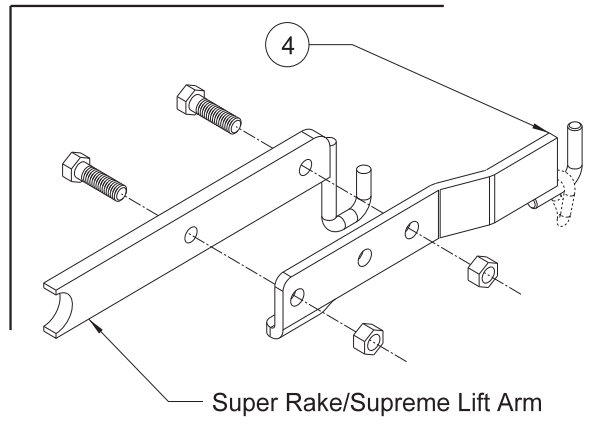

43-002 FLEXACTION FIELD FINISHER WITH BRUSH INSTRUCTIONS

ASSEMBLY INSTRUCTIONS

1. Install flail bar strap (Ref 20) to center of mounting bar (Ref 19) with chain on top of flail bar strap and mounting bar bent away from you. Apply a light coat of lubricant to overall length of mounting bar.
2. Install one rasp flail (Ref 16) with knobby side down adjacent to sides of flail bar strap (Ref 20). Now install a flat washer (Ref 18) so it sits adjacent with the outside of the rasp flail. Continue to install flails with knobby sides down with washers between until you have 16 flails and washers on each side of bar strap. Force all flails tightly toward bar strap.
3. After all 32 flails have been installed, place one spacer (Ref 17) to each end of mounting bar adjacent to washer.
4. Install leveler bar (Ref 9) to mounting bar, with curved leveler bar resting on top on the smooth sides of flails. If all flails and washers do not fit snugly at this time, remove leveler bar and install enough machine bushings to ensure a snug fit. Then reinstall leveler bar.
5. Lay the frame (Ref 6) on the floor or bench with welded tabs facing up. Install ends of assembled mounting bar, with knobby sides of flails up, into welded tabs on each end of frame and secure with $\frac{1}{8}$ x 1 cotter pin.
6. Install flail bar strap (Ref 20) to center tab on frame with $\frac{3}{8}$ -16 x 1 bolt and $\frac{3}{8}$ -16 center lock nut. Loose fit is required. Do not over tighten.
7. Flip assembly over so knobby sides of flails are now facing down. Install hitch (Ref 25) to frame with clevis pin (Ref 3) and cotter pin (Ref 24). The hitch should be attached to the frame as shown.
8. Install bar strap chain over welded pin on frame. Install leveler bar chain on to pin and secure in place with bridge pin. Use last bridge pin and clevis pin to hitch field finisher to your machine.
9. Add extension arms (Refs 4 & 22) to rake lift. **Super Star** - use the center hole and only (1) $\frac{3}{8}$ -16 x $1\frac{1}{4}$ bolt per arm. **Supreme & Super Rake(see sidebar)** - use the two outside holes on the extension arms and (2) $\frac{3}{8}$ -16 x $1\frac{1}{4}$ bolts per arm. Hook lift chains to extension arms (Refs 4 & 22).

OPERATING INSTRUCTIONS

Running attachment with all flails down, flat on the surface, will provide a leveling function. Running attachment partially raised and flails at a 20° - 40° angle in relation to the level surface, will provide a finishing function. The flails increase down pressure for desired finish. Drive in wide circular patterns and increase or decrease ground speed to achieve desired finish.

BRUSH ASSEMBLY

1. Place the brush (Ref 15) into the brush track (Ref 14). Place the brush channel (Ref 13) between the brush track and the mounting brackets. Now bolt the mounting brackets (Ref 10) to the brush track using the $\frac{1}{4}$ -20 x $\frac{3}{4}$ bolts and $\frac{1}{4}$ -20 flange whiz-lock nuts (Ref 12).
2. Mount the brush assembly to the frame using the (4) $\frac{1}{4}$ -20 x $2\frac{1}{2}$ bolts and $\frac{1}{4}$ -20 flange whiz-lock nuts (Ref 11).

26-008 FLEX ACTION FIELD FINISHER DRAWING

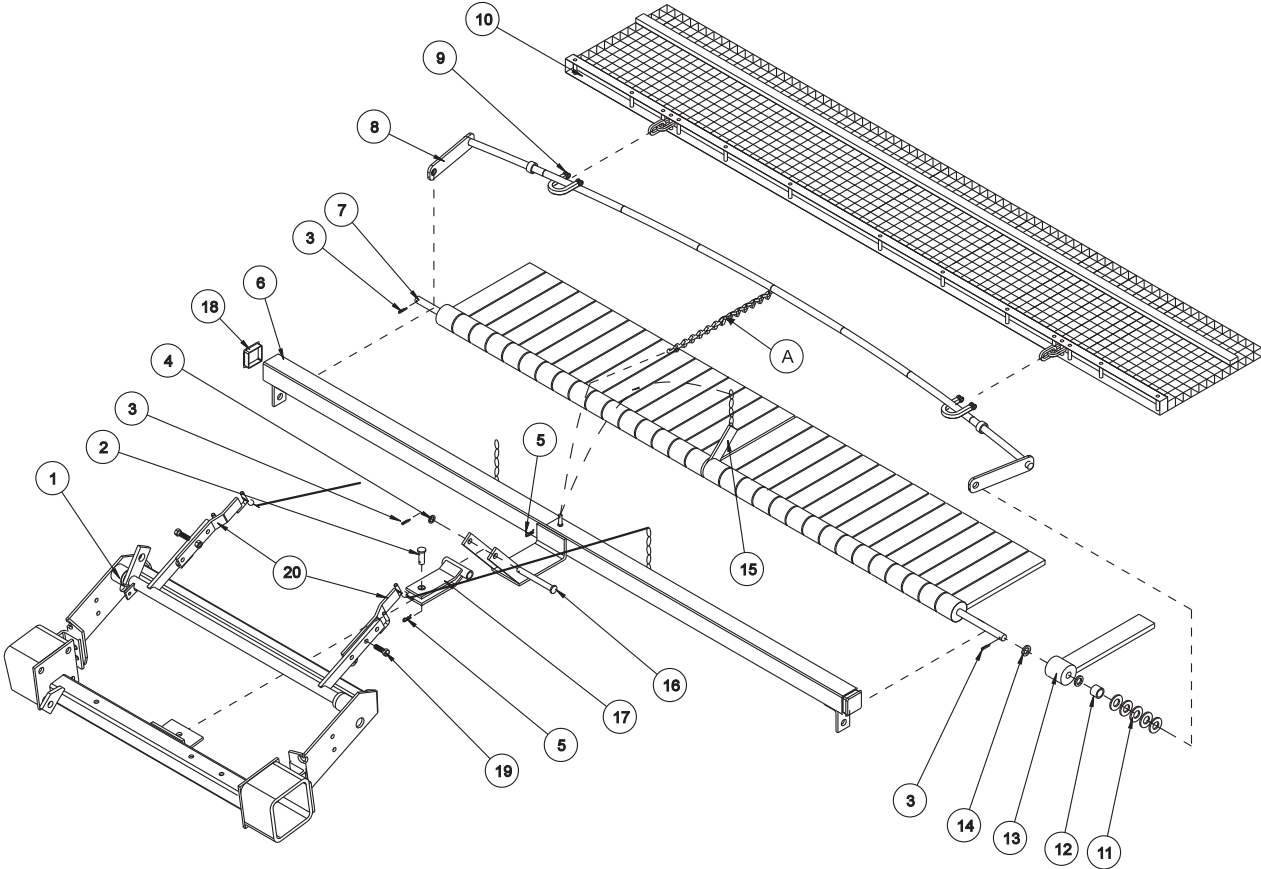

Accessories

26-008 FLEX ACTION FIELD FINISHER PARTS LIST

REF#	PART#	DESCRIPTION	QUANTITY
1	42-024	Rake Lift (comes with machine)	1
2	HCP-12-150	Clevis Pin $\frac{1}{2} \times 1\frac{1}{2}$	1
3	HP-18-100	Cotter Pin $\frac{1}{8} \times 1$	3
4	HMB-12-14	Machine Bushing $\frac{1}{2}$ - 14GA	1
5	HHP-18	Bridge Pin $\frac{1}{8}$	2
6	26-046	Frame	1
7	26-049	Mounting Bar	1
8	26-047	Leveler Bar	1
9	21-260	$\frac{3}{8}$ Chain Clevis	2
10	26-115	Mesh Finisher	1
11	HMB-58-14	Machine Bushing $\frac{5}{8} \times 14$ GA	10
12	11-040	Spacer $\frac{3}{4}$ "	2
13	26-041	Rasp Flail	32
14	HW-58	Washer $\frac{5}{8}$	32
15	26-048	Flail Bar Strap	1
	HB-38-16-100	Bolt $\frac{3}{8}$ - 16 x 1	1
	HNCL-38-16	Center Lock Nut $\frac{3}{8}$ - 16	1
16	HCP-12-450	Clevis $\frac{1}{2} \times 4\frac{1}{2}$	1
17	19-107	Hitch	1
18	18-297	Cap Plug	2
19	HB-38-16-125	Bolt $\frac{3}{8}$ - 16 x $1\frac{1}{4}$	4
	HNTL-38-16	Lock Nut $\frac{3}{8}$ - 16	4
20	26-116	Right Extension Arm	1
	26-117	Left Extension Arm	1

26-008 FLEX ACTION FIELD FINISHER DRAWING

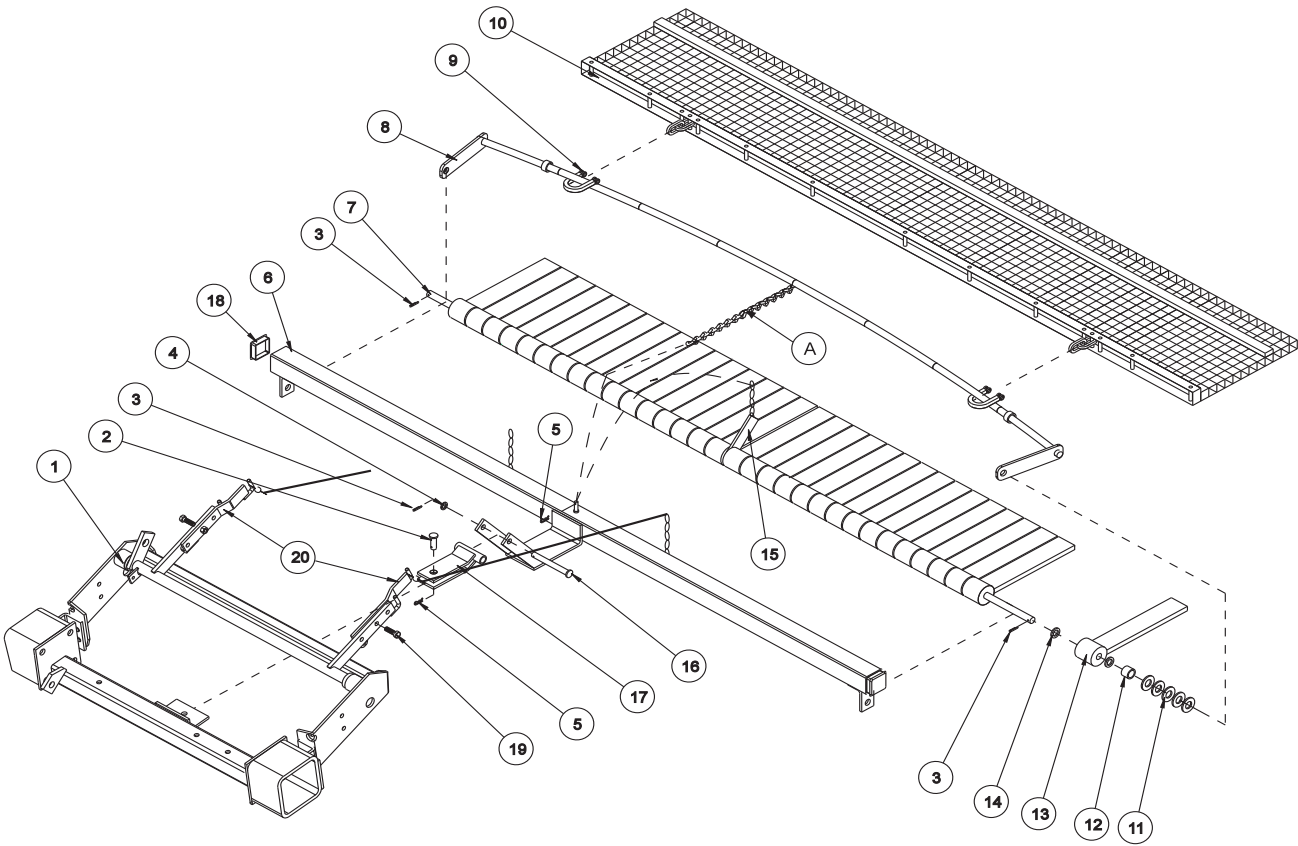

Accessories

INSTALLATION INSTRUCTIONS

1. Install flail bar (Ref 15) strap to center of mounting bar (Ref 7) with chain on top of flail bar strap and mounting bar bent away from you. Apply a light coat of lubricant to overall length of mounting bar.
2. Install one rasp flail (Ref 13) with knobby side down adjacent to sides of flail bar strap (Ref 15). Now install a flat washer (Ref 14) so it sits adjacent with the outside of the rasp flail. Continue to install flails with knobby sides down with washers between until you have 16 flails and washers on each side of bar strap. Force all flails tightly toward bar strap.
3. After all 32 flails have been installed, place one spacer (Ref 12) to each end of mounting bar adjacent to washer.
4. Install leveler bar (Ref 8) to mounting bar, with curved leveler bar resting on top on the smooth sides of flails. If all flails and washers do not fit snugly at this time, remove leveler bar and install enough machine bushings to ensure a snug fit. Then reinstall leveler bar.
5. Lay the frame (Ref 6) on the floor or bench with weld tabs facing up. Install ends of assembled mounting bar, with knobby sides of flails up, into welded tabs on each end of frame and secure with cotter pin (Ref 3).
6. Install flail bar strap (Ref 15) to center tab on frame with $\frac{3}{8}$ -16 x 1 bolt and $\frac{3}{8}$ -16 center lock nut. Loose fit is required. No not over tighten
7. Flip assembly over so knobby sides of flails are now facing down. Install hitch (Ref 17) to frame with clevis pin (Ref 16) and cotter pin (Ref 3) . The hitch should be attached to the frame as shown.
8. Install bar strap chain over welded pin on frame. Install leveler bar chain on to pin and secure in place with bridge pin. Use last bridge pin and clevis pin to hitch field finisher to your machine.
9. Add extension arms (Ref 20) to rake lift. **Super Star** - use the center hole and only (2) $1\frac{1}{4}$ bolts (Ref 19). **Supreme & Super Rake** - use the two outside holes on the extension arms and (4) $1\frac{1}{4}$ bolts. Hook lift chains to extension arms (Ref 20).

OPERATING INSTRUCTIONS

Running attachment with all flails down, flat on the surface, will provide a leveling function. Running attachment partially raised and flails at a 20° - 40° angle in relation to the level surface, will provide a finishing function. The flails increase down pressure for desired finish. Drive in wide circular patterns and increase or decrease ground speed to achieve desired finish.

MESH FINISHER

To get a smoother finish, Install a Mesh Finisher onto your Flex Action Field Finisher.

1. If the 26-008 flex action field finisher is on your machine, lower it to the ground. You may have to pull machine ahead slightly so the field finisher is lying flat on the ground or floor.
2. Lay mesh finisher behind field finisher with weight bar facing up and chain hooks towards field finisher.
3. Take the two chain clevis' and hook onto leveler bar and then thorough the chain hooks on mesh finisher. The clevis pin that comes with the chain clevis should go through the chain clevis, first link on chain hook (on the mesh finisher) and then through other side of the chain clevis. Insert the cotter pin.
4. Center mesh finisher with flex action field finisher.
5. Raise lift on your machine to insure proper ground clearance before driving your machine.
6. (Ref A) Chain length is to control amount of mesh trailing behind flails for wet or dry conditions. For wet conditions: Shorten chains. For dry conditions: May use maximum amount of chain to make desired finish.



43-043 FINISHING BRUSH KIT DRAWING

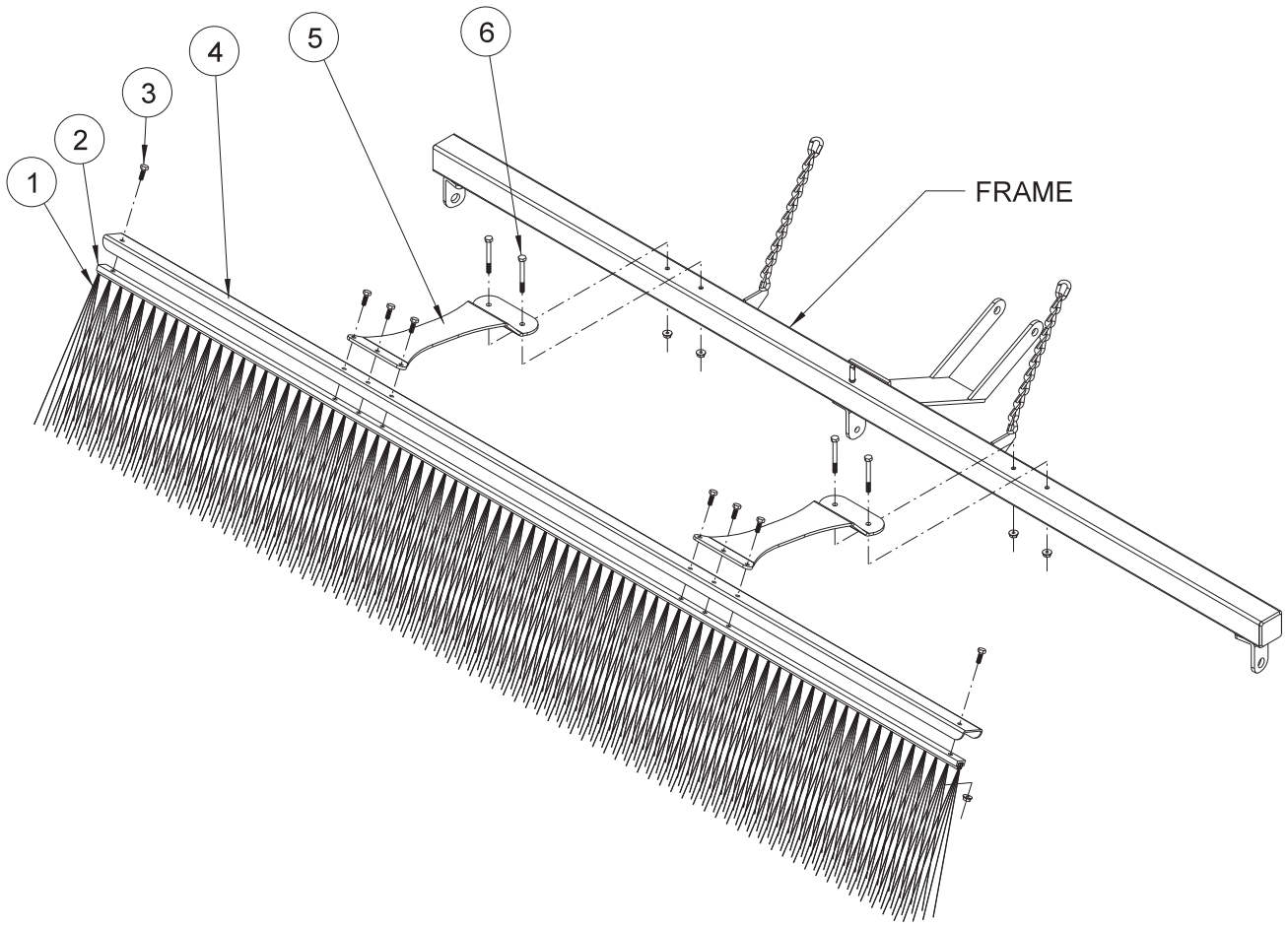

HOLE LOCATION

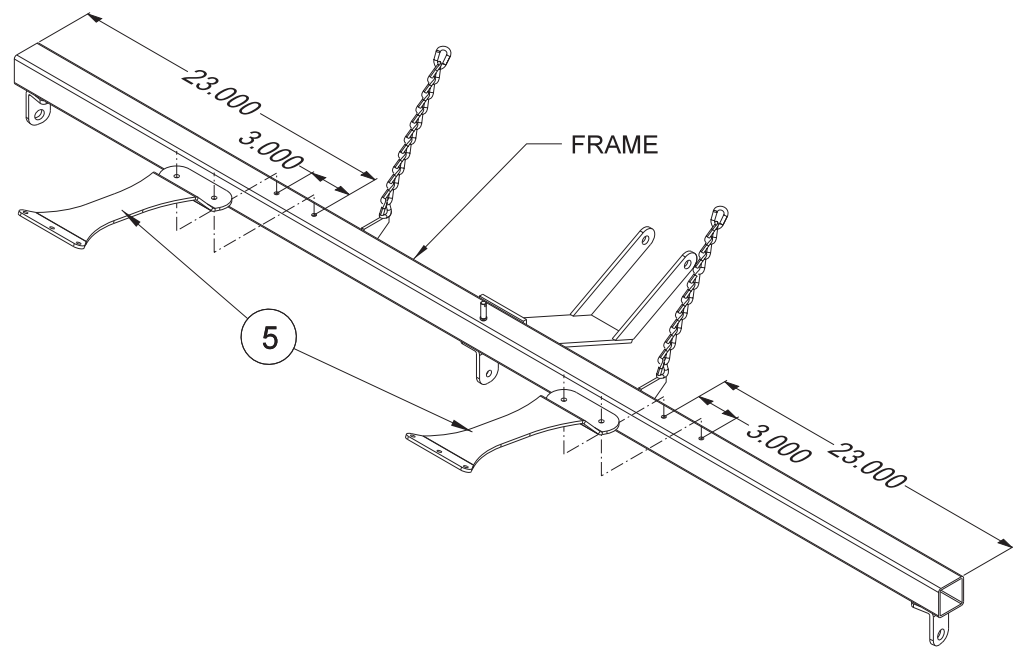

Accessories

43-043 FINISHING BRUSH KIT PARTSLIST

REF#	PART#	DESCRIPTION	QUANTITY
1	13-682	Brush, 77 x 11	1
2	13-683	Brush Track	1
3	HB-14-20-075	Bolt, 1/4 - 20 x 3/4	8
	HNFL-14-20	Flange Whiz-Lock Nut, 1/4 - 20	8
4	13-688	Brush Channel	1
5	43-041	Mount Bracket	2
6	HB-14-20-250	Bolt, 1/4 - 20 x 2 1/2	4
	HNFL-14-20	Flange Whiz-Lock Nut, 1/4 - 20	4

INSTALLATION INSTRUCTIONS

1. Remove the mesh finisher from your unit, it will not be used with the brush.
2. Place the brush (Ref 1) into the brush track (Ref 2). Place the brush channel (Ref 4) between the brush track and the mounting brackets (Ref 5). Now bolt the mounting brackets (Ref 5) to the brush track using the 1/4 - 20 x 3/4" bolts and 1/4 - 20 flange whiz-lock nuts (Ref 3).
3. Four holes need to be drilled into the frame of the Flex Action Finisher to mount the brush. Drill two $\text{Ø}^{9/32}$ holes 23" in from each end and 3" apart (see Reference drawing).
4. Mount the brush assembly to the frame using the four 1/4 - 20 x 2 1/2" bolts and 1/4 - 20 flange whiz-lock nuts (Ref 5).

42-582 GREEN STAR RBS SPIKER SET (3) DRAWING

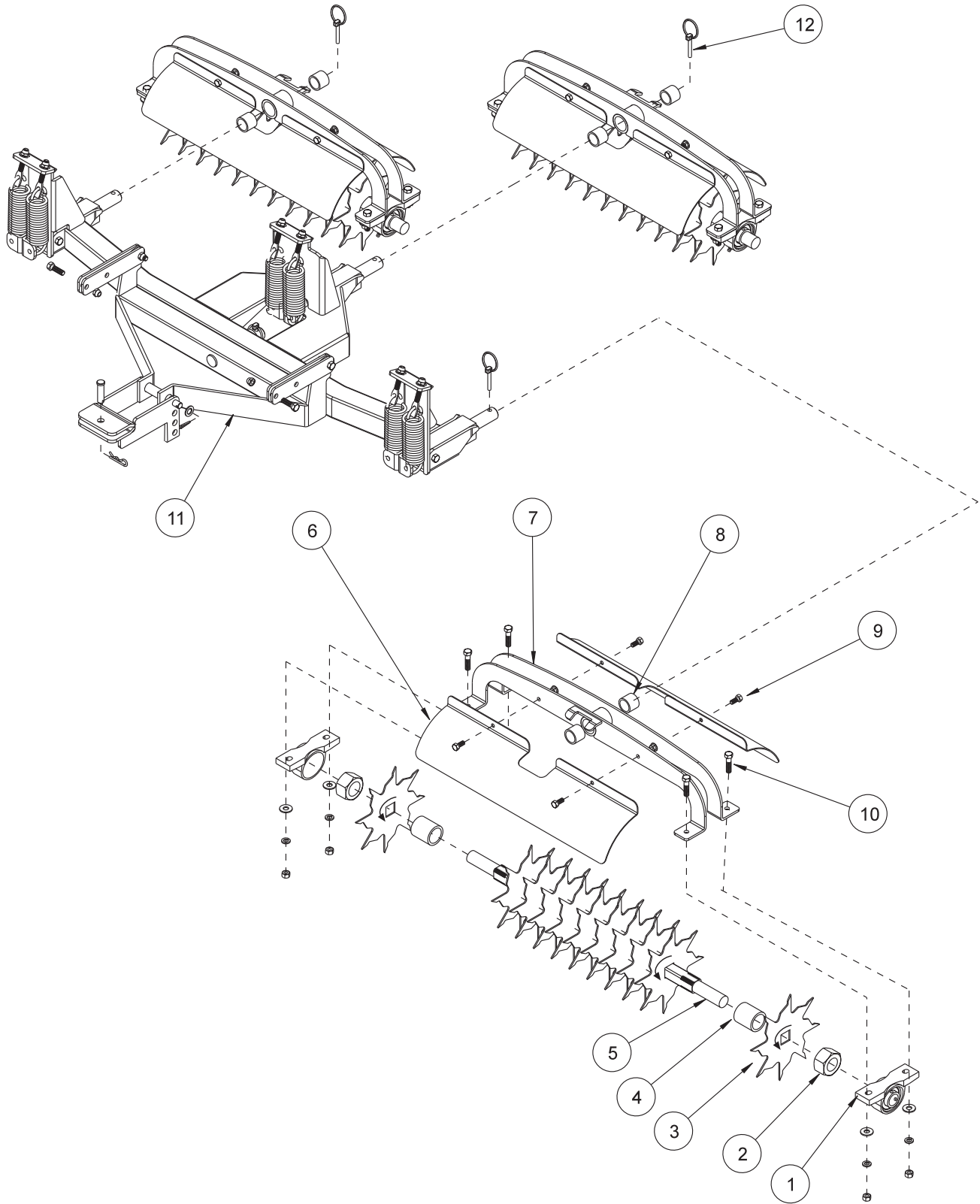

Accessories

42-582 GREEN STAR RBS SPIKER SET (3) DRAWING

REF#	PART#	DESCRIPTION	QUANTITY
1	11-094	Pillow Block	6
2	HNJ-114-12	Jam Nut 1 ¹ / ₄ - 12	6
3	42-583	Spiker Blade	33
4	8965-1.875	Spiker Blade Spacer (1.875")	30
5	42-554	Spiker Shaft	3
6	42-578	Spiker Cover	6
7	42-574	Fork	3
8	18-295	Oilite Bushing (part of 42-574)	6
9	HB-516-18-075	Bolt ⁵ / ₁₆ - 18 x ³ / ₄	12
	HNTL-516-18	Lock Nut ⁵ / ₁₆ - 18	12
10	HB-38-16-150	Bolt ³ / ₈ - 16 x 1 ¹ / ₂	12
	HWL-38	Lock Washer ³ / ₈	12
	HW-38	Washer ³ / ₈	24
	HN-38-16	Nut ³ / ₈ - 16	12
11	42-586	Green Star RBS Main Frame	1
12	42-539	Lynch Pin ⁵ / ₁₆ (part of main frame)	3

ADJUSTMENTS AND OPERATION INSTRUCTIONS

ADJUSTMENT

The springs are preset for maximum down pressure, and should not need to be adjusted. If you feel the need to adjust the springs please call for further instructions. The unit comes pre-adjusted for most models. When installing spiker system use lower mounting holes on hitch.

Tire pressure should be 4 psi in the front and 7 psi in the rear tire for best traction.

OPERATION

Make sure the spiker system has been installed and adjusted properly for your model of bunker rake. Always transport in fully raised position. Always remove flag pole before spiking green. Do not stop on green while spiking. Do not spike up steep slopes or loss of traction may result. Do not turn while spiking.

To begin spiking, lower unit all the way down as you come across collar and continue straight across green until reaching other collar and raise as you come off of green. Overlap stripes the same as if you were mowing.

INSTALLATION

Spiker blades must be installed so that the jagged side of the tooth cuts into the turf first. This allows only a piercing of the turf, whereas if the straight edge of the spiker blades enters first it will act more as a cutting effect.

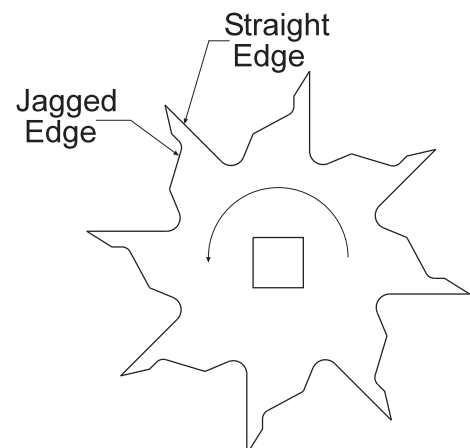

42-586 GREEN STAR RBS MAIN FRAME DRAWING

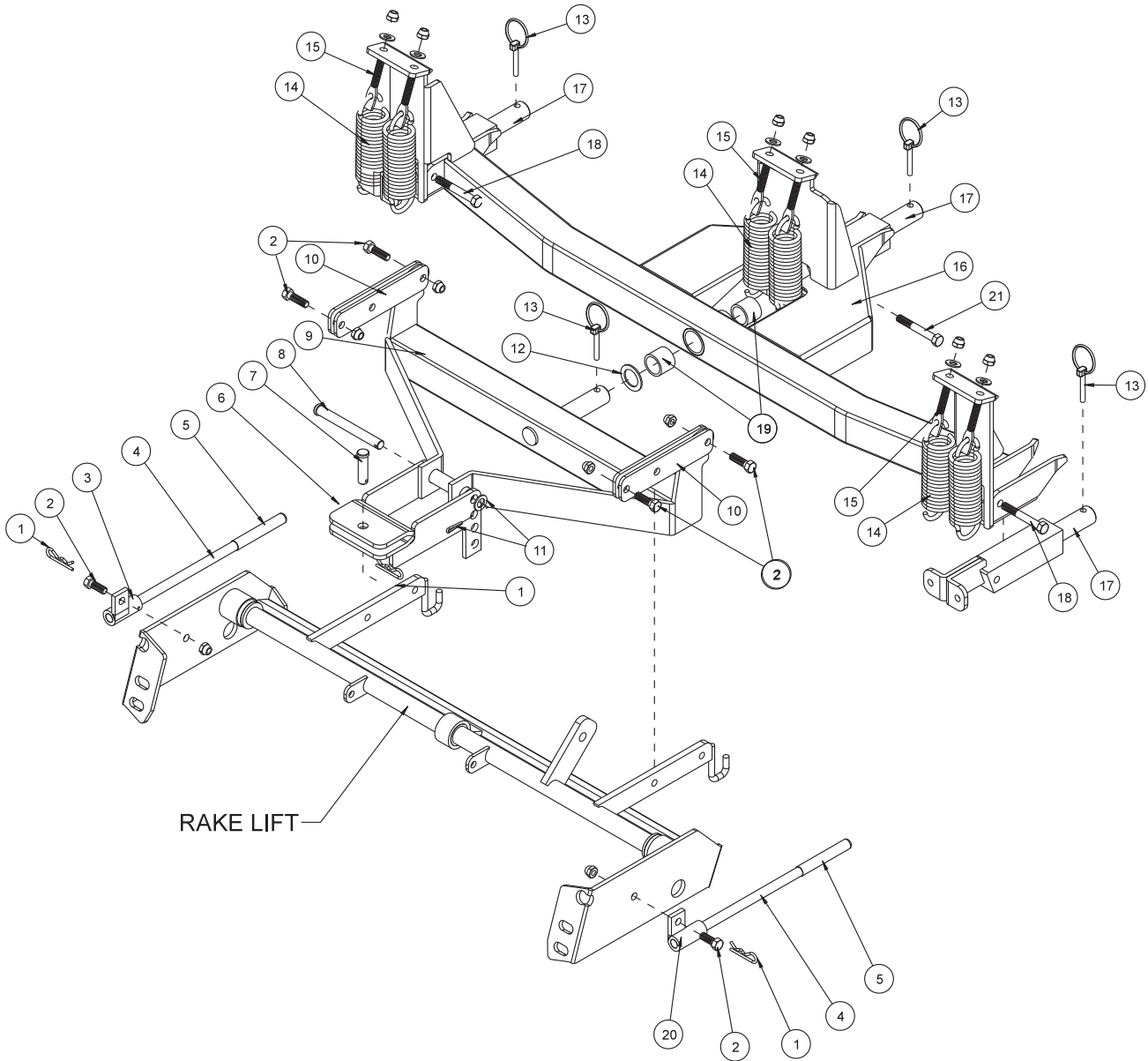

Accessories

42-586 GREEN STAR RBS MAIN FRAME PARTS LIST

REF#	PART#	DESCRIPTION	QUANTITY
1	HHP-18	Bridge Pin $\frac{1}{8}$	3
2	HB-38-16-125	Bolt $\frac{3}{8}$ - 16 x $1\frac{1}{4}$	6
	HNTL-38-16	Lock Nut $\frac{3}{8}$ - 16	6
3	42-525	Right Rod Holder	1
4	42-580	Stabilizer Rods	2
5	13-499	Grip	2
6	42-565	Hitch	1
7	HCP-12-175	Clevis Pin $\frac{1}{2}$ - $1\frac{3}{4}$	1
8	HCP-12-450	Clevis Pin $\frac{1}{2}$ - $4\frac{1}{2}$	1
9	42-575	Three Point Hitch	1
10	42-566	Lift Strap	4
11	HMB-12-14	Machine Bushing $\frac{1}{2}$ x 14GA	1
	HP-18-100	Cotter Pin $\frac{1}{8}$ x 1	1
12	HMB-100-14	Machine Bushing 1 x 14GA	1
13	42-539	Lynch Pin $\frac{5}{16}$	4
14	42-536	Spring	6
15	42-537	Spade Bolt	6
	HNTL-38-16	Lock Nut $\frac{3}{8}$ - 16	6
16	42-577	Frame	1
17	42-576	Spring Tower	3
18	HB-38-16-275	Bolt $\frac{3}{8}$ - 16 x $2\frac{3}{4}$	2
	HNTL-38-16	Lock Nut $\frac{3}{8}$ - 16	2
19	18-295	Oilite Bushing (part of 42-577)	2
20	42-524	Left Rod Holder	1
21	HB-38-16-250	Bolt $\frac{3}{8}$ - 16 x $2\frac{1}{2}$	1
	HNCL-38-16	Center Lock Nut $\frac{3}{8}$ - 16	1

GREEN STAR RBS MOUNT FOR SMITHCO SUPER STAR

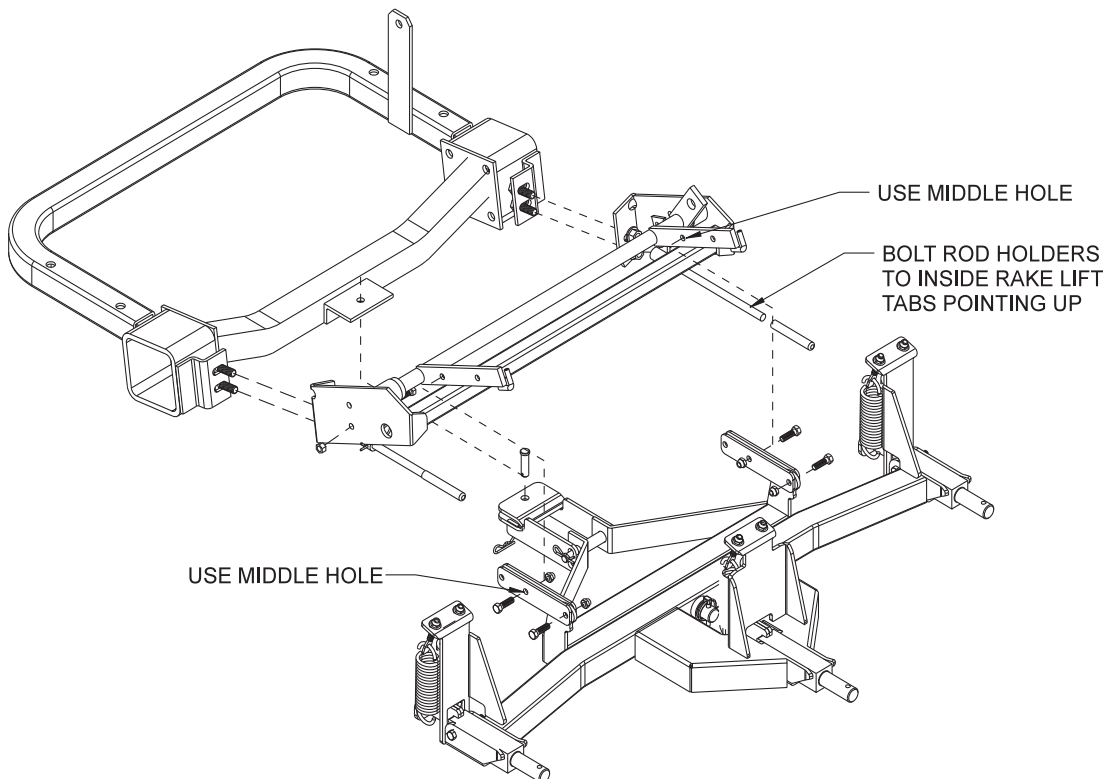

This is a list of decals located on the Super Star. Part number, description and location will help in reordering decals.

13-556	Decal, Warning	1	Left Side Below Seat
25-277	Decal, Battery	1	Bottom Seat
25-286	Decal, Pinch Point	1	Bottom Seat Panel
25-298	Decal, Warning Hot	2	Bottom Seat Panel. Oil Filter Bracket
25-337	Decal, Speed Boss	1	Hang from Steering
25-344	Decal, Smithco 3" Star	1	Steering Column
25-349	Decal, Foot Pedal	1	Right Side Nose Cone
25-352	Decal, By-Pass Valve	1	Hang Tag
25-354	Decal, Tire Pressure 5psi	2	Rear Wheels
25-357	Decal, Smithco	1	Front Nose Cone
25-379	Decal, Fluid Filled Tires	1	Front Tire
27-077	Decal, Smithco Round	1	Steering Cap
43-110	Decal, Super Star	2	Nose Cone
42-765	Decal, Lift Control	1	Right Body Top
42-764	Decal, Control Panel	1	Left of Seat
43-133	Decal, X-Treme	2	Nose Cone

OPTIONAL EQUIPMENT

42-011	Front Mounted Manual Plow	42-026	Stainless Steel Tournament Rake 84"
43-003	Hydraulic Sand Plow	42-128	Stainless Steel Tournament Rake 72"
42-136	Front Mounted 60" Manual Plow	42-130	Mild Steel Tournament Rake 84"
42-460	40" Adjustable Angle Plow	42-132	Mild Steel Tournament Rake 72"
42-490	60" Adjustable Angle Plow	42-391	72" Multi Brush Rake
43-130	Weed Cultivator	42-392	84" Multi Brush Rake
42-008	Sand Cultivator	13-438	Rake Assembly with Finishing Blades
42-340	Sand Cultivator w/ Spring Tine	13-684	Brush Kit (for 13-438)
42-341	Sand Cultivator w/ Castor Wheels	13-740	Brush Attachment - 84"
42-285	Scarifier w/ Vertical Blades	42-223	Edger Kit
42-010	Construction Leveling Blade	43-004	Grader Blade Kit
26-007	Professional Infield Finisher	42-794	Ball Mount Kit
26-008	Flex Action Field Finisher	42-750	Razor Edger Kit
43-043	Brush Kit (for 26-008)	13-319	Fan Rake Kit
43-002	Flex Action Field Finisher with Brush	13-298	Fan Rake Attachment
43-088	Drag Mat Kit	42-188	Drag Mat
42-315	Light Kit	42-800	ROPS
34-191	Box Grader		
42-178	Infield Scarifier (w/ Straight Blades & Castor Wheels)		
42-179	Infield Scarifier (w/ Chisel Blades & Castor Wheels)		
42-581	Green Star Roller Set (needs 42-586 main frame)		
42-582	Green Star Spiker Set (needs 42-586 main frame)		
42-585	Green Star Brush Set (needs 42-586 main frame)		
42-586	Green Star Main Frame		
42-550	Greens Star Roller, Brush, Spiker System with Main Frame		

QUICK REFERENCE REPLACEMENT PARTS

REPLACEMENT FILTERS

23-031	Hydraulic Oil Filter	
15-165-01	Air Filter Element with Pre-Cleaner	Briggs and Stratton# 5050
42-076-03	Air Filter Element Fender Mounted	
50-403	Fuel Filter	
13-531	Engine Oil Filter	Briggs and Stratton #492932

SEAL KITS

43-127	Variable Pump	
13-615	Wheel Motor	
14-080	Seal Kit	
76-238	Wheel Motor	
14-080	Seal Kit	
13-729	2-Bank Valve	
78-415-03	Seal Kit	
10-135	Hydraulic Cylinder (Attachment Lift Cylinder)	
13-357	Hydraulic Cylinder for Rake Lift	
14-267	Seal Kit	
75-714	Hydraulic Cylinder for Sand Plow Lift	
14-254	Seal Kit	

FLUIDS

Engine Oil	Refer to Engine Manual
Hydraulic Fluid	SAE 10W-40 API Service SJ or higher Motor Oil

OTHER PARTS

Spark Plugs	RC12YC (Gap 0.030 inch (0.76mm))
-------------	----------------------------------

The Smithco Commercial Products Two-Year Limited Warranty

Smithco, Inc. (Smithco) warrants your 2007 or newer Smithco Commercial Product ("Product") purchased after January 1, 2007, to be free from defects in materials or workmanship for the period of time listed below. Where a warrantable condition exists, Smithco will repair the Product at no cost to you including diagnosis, labor (at the Smithco standard labor rate, subject to the Smithco flat rate schedule), and parts.

Warranty Duration is:

- (1) Two years, 1500 operational hours* from the date of delivery to the original purchaser or three years from the date of original manufacturer of the product, whichever occurs first. (*Products equipped with hour meter).
- (2) Products used in rental situations are covered for 90 days from date of delivery to original user/ renter.

Owner Responsibilities:

As the Product owner, you are responsible for required maintenance and adjustments stated in your Owner's Manual. Failure to perform required maintenance and adjustments can be grounds for disallowing a warranty claim. **You are particularly responsible to train all present and future operators of this product on the safe operation of this product at your location.**

Instructions for Obtaining Warranty Service:

You are responsible for notifying the Authorized Smithco Products Distributor from whom you purchased the Product as soon as you believe a warrantable condition exists and not later than 30 days from discovery of the condition.

If you need help locating an Authorized Smithco Distributor, or if you have questions regarding your warranty rights or responsibilities, you may contact us at:

Smithco Product Support Department
200 W Poplar PO Box 487
Cameron, Wisconsin 54822

Telephone: 1-800-891-9435 E-Mail: ProductSupport@smithco.com

Maintenance Parts:

Parts scheduled for replacement as required maintenance ("Maintenance Parts"), are warranted for the period of time up to the scheduled replacement time for that part.

Items/Conditions Not Covered:



Not all product failures or malfunctions that occur during the warranty period are defects in materials or workmanship. The items/conditions listed below are not covered by this warranty:



Product failures which result from the use of non-Smithco replacement parts, or from installation and use of add-on, modified, or unapproved accessories are not covered.



Product failures which result from failure to perform required maintenance and/or adjustments are not covered.



Product failures that result from operating the Product in an abusive, negligent or reckless manner are not covered.



This warranty does not apply to parts subject to consumption through use, unless found to be defective. Examples of parts which are consumed, or used up, during normal Product operation include, but are not limited to: blades, tines, teeth, scarifiers, rakes, plates, wear plates, castor wheels, tires, batteries, filters, belts, nozzles, etc.



This warranty does not apply to failures caused by outside influence. Items considered to be outside influence include, but are not limited to, weather, storage practices, contamination, use of unapproved coolants, lubricants, additives, or chemicals, etc.



This warranty does not apply to normal “wear and tear” items. Normal “Wear and Tear” includes, but is not limited to, damage to seats due to wear or abrasion, worn painted surfaces, scratched decals or windows, etc.



Smithco may require the return of failed parts or components in order to determine the validity of any warranty claim.



Smithco will not be obligated to replace components of other manufacturers if inspection by the original component manufacturer indicates that failure was due to normal wear and tear, expected consumption through use or improper care or service.

Other Legal Disclaimers:

The above remedy for product defects through repair or replacement by an authorized Smithco distributor or dealer is the purchaser’s sole remedy for any defect. This warranty gives you specific legal rights, and you may also have other rights which vary from state to state.

THERE ARE NO OTHER EXPRESS WARRANTIES OTHER THAN THOSE SET FORTH ABOVE. ALL IMPLIED WARRANTIES OF MERCHANTABILITY AND FITNESS FOR USE ARE LIMITED TO THE DURATION OF THE LIMITED WARRANTIES CONTAINED HEREIN.

Some states may not allow limitations on how long an implied warranty lasts, so the above limitation may not apply to you.

THE SMITHCO COMPANY IS NOT LIABLE FOR INDIRECT, INCIDENTAL OR CONSEQUENTIAL DAMAGES IN CONNECTION WITH THE USE OF THE PRODUCT, INCLUDING ANY COST OR EXPENSE OF PROVIDING A SUBSTITUTE PRODUCT OR SERVICE DURING PERIODS OF MALFUNCTION OR NON-USE.

Some states may not allow the exclusion of indirect, incidental or consequential damages, so the above exclusion may not apply to you.

Smithco neither assumes, nor authorizes any person to assume for it, any other liability in connection with the sale or use of this product.

SMITHCO, INC.

Wayne, PA 19087

