

Parts & Service

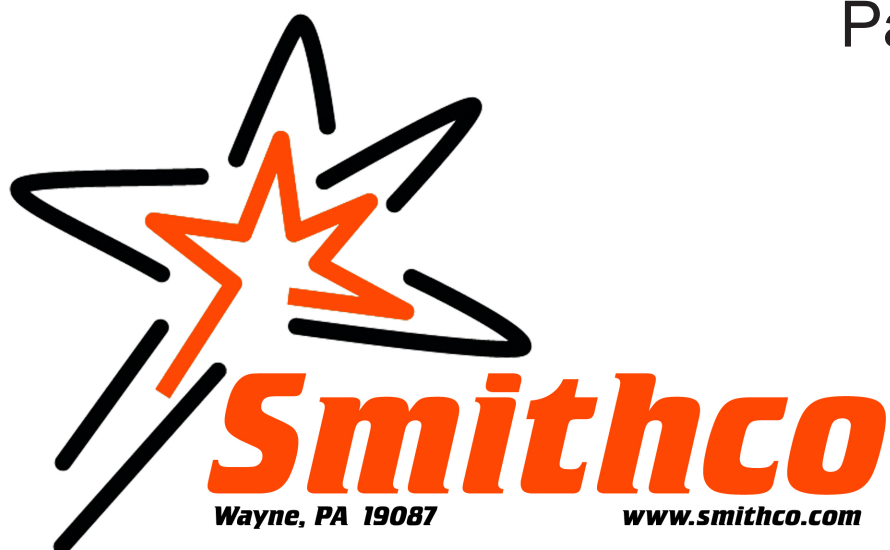

# **Spray Star 1750**

## **Model 15-600-B**

**TeeJet Spray Systems**  
**SN: 175G318**

**September 2018**

***Product Support:***

***Hwy 55 & Poplar Ave; Cameron WI 54822***

***1-800-891-9435    [productsupport@smithco.com](mailto:productsupport@smithco.com)***

# CONTENTS

## Introduction.....1-3

Introduction.....	1
General Safe Practices.....	2
Specifications .....	3
Optional Spray Equipment.....	3

## Service.....4-9

Maintenance.....	4-6
Storage.....	6
Wheel Creep.....	7
Service Chart.....	8
End User's Service Chart.....	9

## Diagrams .....10-13

Wiring Diagram.....	10-11
Hydraulic Diagram.....	12-13

## Parts.....14-45

Body & Frame .....	14-15
Nose Cone .....	16-19
Front Axle .....	20-21
Oil Tank and Fuel Tank .....	22-23
Seat Panel.....	24-25
Engine Pumps and Exhaust.....	26-29
Spray Pump.....	30-31
Spray Tank.....	32-33
Turbo Quad Agitator .....	34-35
Park Brake and Rear Axle .....	36-37
15-301 Orbitor .....	38-39
76-482 Hydrostatic Pump.....	40-41
76-197 Eaton Gear Pump.....	42-43
16-998 Hypro® Pump .....	44-45

## Accessories .....46-100

Plumbing 1752 System (Radion® 8140) .....	46-47
Plumbing 1754 System (TeeJet® 744) .....	48-49
Plumbing 1755 System (DynaJet + Aeros®).....	50-51
Dynajet Module Mounts.....	52
1752 Wiring System(Radion® 8140) .....	53
1754 Wiring System (TeeJet® 744) .....	54
1755 Wiring System - Aeros® .....	55
Wiring System - DynaJet® .....	56
14-801 Agitation Strainer.....	57
16-524 Motorized Control Valve .....	58
15-737/14-628 Flanged Strainer.....	59
15-743 Manifold Ball Valve .....	60
20-685 Regulator Valve .....	61
17-585 18' HD Super Boom .....	62-64
17-585 18' HD Super Boom Plumbing .....	65-66
17-580 20' HD Super Boom .....	67-71
17-580 20' HD Super Boom Plumbing .....	72-73
QJS Nozzle Assembly .....	74
QJS Bottom Mounted Nozzle Assembly.....	75
Triple Nozzle Assembly .....	76
15-835 Tank Rinsing System.....	77
16-906 Electric Hose Reel .....	78-79
Electric Hose Reel Wiring Diagram .....	80
Hose Reel Adjustments .....	81
16-129 Manual Hose Reel .....	82
14-308 Hose Reel for HD Booms .....	83
Hose Reel Plumbing.....	84-85
17-505 Foam Marker Installation.....	86-89
14-291 Foam Marker Parts List.....	90-91
Foam Marker Wiring .....	92
10-653 Fresh Water Tank - Front Mount.....	93
30-006 Fresh Water Tank - Rear Mount .....	94
14-515 Water Meter Kit (Gallons).....	95
15-618 Water Meter Kit (Liters) .....	95
15-619 Chemical Clean-load System.....	96-100

## Reference .....101-102

Decal List.....	101
Quick Reference Replacement Parts .....	102
Limited Warranty	

Thank you for purchasing a **Smithco** product.

Read this manual and all other manuals pertaining to the Spray Star 1750 carefully as they have safety, operating, assembly and maintenance instructions. Failure to do so could result in personal injury or equipment damage.

Keep manuals in a safe place after operator and maintenance personnel have read them. Right and left sides are from the operator's seat, facing forward.

 <p><b>WARNING:</b></p> <p><b>Engine exhaust and some of its constituents are known to the State of California to cause cancer, birth defects, and other reproductive harm.</b></p> <p><b>For more information visit <a href="http://www.P65Warning.ca.gov">www.P65Warning.ca.gov</a></b></p>	<p><b>WARNING</b></p> <p><i>Failure to follow cautious operating practices can result in serious injury to the operator or other persons. The owner must understand these instructions, and must allow only trained persons who understand these instructions to operate this vehicle.</i></p>
--	--

All **Smithco** machines have a Serial Number and Model Number. Both numbers are needed when ordering parts. The serial number plate on the Spray Star 1750 is located on the left main frame, by front bumper. Refer to engine manual for placement of engine serial number.

For product and accessory information, help finding a dealer, or to register your product please contact us at [www.Smithco.com](http://www.Smithco.com).

Information needed when ordering replacement parts:

1. Model Number of machine
2. Serial Number of machine
3. Name and Part Number of part
4. Quantity of parts

For easy access record your Serial and Model numbers here.

<b>SMITHCO</b> WAYNE, PENNSYLVANIA 19087 USA 610-688-4009 Fax 610-688-6069			
SERIAL NO.	kW/hp	DATE OF MFG.	
<input type="text"/>	<input type="text"/>	<input type="text"/>	
MODEL NO.	lb/kg Empty	lb/kg Full	
<input type="text"/>	<input type="text"/>	<input type="text"/>	

**SMITHCO CUSTOMER SERVICE 1-800-891-9435**

## SAFE PRACTICES

1. It is your responsibility to read this manual and all publications associated with this machine.
2. Never allow anyone to operate or service the machine or its optional equipment without proper training and instructions. Never allow minors to operate any equipment.
3. Learn the proper use of the machine, the location and purpose of all the controls and gauges before you operate the equipment. Working with unfamiliar equipment can lead to accidents.
4. Wear all the necessary protective clothing and personal safety devices to protect your head, eyes, ears, hands and feet. Operate the machine only in daylight or in good artificial light.
5. Inspect the area where the equipment will be used. Pick up all debris you can find before operating. Beware of overhead obstructions and underground obstacles. Stay alert for hidden hazards.
6. Never operate equipment that is not in perfect working order or without decals, guards, shields, or other protective devices in place.
7. Never disconnect or bypass any switch.
8. Carbon monoxide in the exhaust fumes can be fatal when inhaled, never operate a machine without proper ventilation.
9. Fuel is highly flammable, handle with care.
10. Keep engine clean. Allow the engine to cool before storing and always remove the ignition key.
11. Disengage all drives and set park brake before starting the engine.
12. Never use your hands to search for oil leaks. Hydraulic fluid under pressure can penetrate the skin and cause serious injury.
13. This machine demands your attention. To prevent loss of control or tipping of the vehicle:
  - A. Use extra caution in backing up the vehicle. Ensure area is clear.
  - B. Do not stop or start suddenly on any slope.
  - C. Reduce speed on slopes and in sharp turns. Use caution when changing directions on slopes.
  - D. Stay alert for holes in the terrain and other hidden hazards.
14. Before leaving operator's position:
  - A. Disengage all drives.
  - B. Set park brake.
  - C. Shut engine off and remove the ignition key.
  - D. If engine has to run to perform any maintenance keep hands, feet, clothing and all other parts of body away from moving parts.
15. Keep hands, feet and clothing away from moving parts. Wait for all movement to stop before you clean, adjust or service the machine.
16. Keep the area of operation clear of all bystanders.
17. Never carry passengers.
18. Stop engine before making repairs/adjustments or checking/adding oil to the crankcase.
19. Use parts and materials supplied by **Smithco** only. Do not modify any function or part.
20. Use caution when booms are down as they extend out beyond the center line of the machine.
21. The tank is a confined space, take precaution.

***These machines are intended for professional maintenance on golf courses, sports turf, and any other area maintained turf and related trails, paths and lots. No guaranty as to the suitability for any task is expressed or implied.***



# SPECIFICATIONS SPRAY STAR 1750

## WEIGHTS AND DIMENSIONS

Length	120" (305 cm)
Width	65" (165 cm)
Width With 18' Boom Open	240" (610 cm)
Height w/ ROPS	77" (195 cm)
Height w/ 18' Booms Folded	110" (279 cm)
Wheel Base	68" (173 cm)
Weight Empty	1750 lbs (794 kg)
Weight Full	3500 lbs (1588 kg)

## SOUND LEVEL (DBA)

At ear level	92 dBA
At 3 ft. (0.914 m)	98 dBA
At 30 ft. (9.14 m)	88 dBA

## ENGINE

Make	Briggs & Stratton
Model#	543477
Type / Spec#	0175G1
Horsepower	31 hp (23 kW)
Fuel	Unleaded 87 Octane Gasoline Minimum
Cooling System	Air Cooled
Lubrication System	Full Pressure
Alternator	20 Amp

## WHEELS & TIRE

Front: Two 20 x 10.00 x 10 NHS Multi-Rib; 20 psi (1.4 bar)  
Rear: Two 24 x 13.00 x 12 NHS Multi-Trac; 20 psi (1.4 bar)

## SPEED

Infinitely Variable 0-12 m.p.h. (0-20 kph)

## BATTERY

	Automotive type 24F - 12 volt
BCI Group	Size 24
Cold Cranking Amps	900 minimum
Ground Terminal Polarity	Negative (-)
Maximum Length	10.25" (26 cm)
Maximum Width	6.88" (17 cm)
Maximum Height	10" (25 cm)

## FLUID CAPACITY

Crankcase Oil	See Engine Manual
Fuel	10 gallon (45.46 liters)
Hydraulic Fluid	5 gallon (19 liters)
Grade of Hydraulic Fluid	SAE 10W-40 API Service SJ or higher Motor Oil

# OPTIONAL EQUIPMENT

15-618	Water Meter Kit (Liters)	14-515	Water Meter Kit (Gallons)
15-619	Chemical Cleanload	17-506	Fresh Water Wash Tank
15-622	Canopy	15-835	Tank Rinsing System
17-505	Foam Marker	14-308	Hose Reel Mount Kit for HD Booms
17-580	20' HD Super Boom	17-585	18.5' HD Super Boom
15-762	Smithco Engineered ROil Bar (SERB)	17-622	Boom SHield for 17-585
30-140	26 Gal. Wash System with Electric Pump		
16-129	Manual Rewind Hose Reel, 200-foot/61-meter capacity		
16-906	Electric Rewind Hose Reel, 200-foot/61-meter capacity		



# MAINTENANCE

## CAUTION

Before servicing or making adjustments to machine, stop engine and remove key from ignition.

## IMPORTANT

Use all procedures and parts prescribed by the manufacturer's. Read the engine manual before operation.

### LUBRICATION

Use No. 2 General purpose lithium base grease and lubricate every 100 hours. The Spray Star 1750 has 9 grease fittings.

- A. One on the rod end of hydraulic cylinder.
- B. One on each the right and left spindles.
- C. One on the center front pivot.
- D. One on the idler arm.
- E. One on the brake relay.
- F. One on each of the pedal relays.
- G. One on the shift arm.

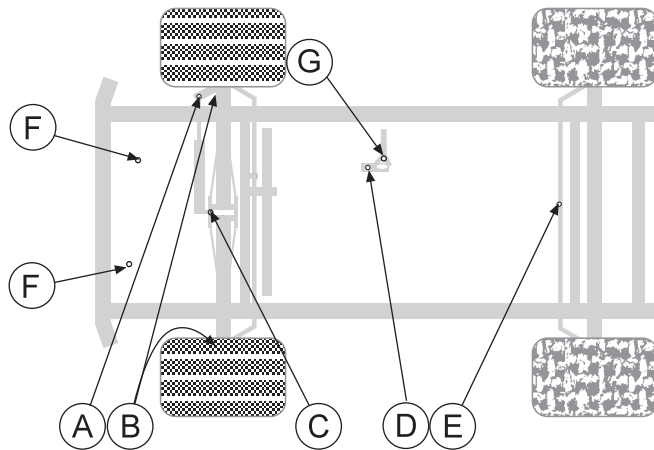

### ELECTRICAL CONNECTIONS

Use dielectric grease on all electrical connections.

### AIR CLEANER ON ENGINE

1. Unclip the two clips, remove the cover and pull out the element.
2. To service, clean by tapping gently on flat surface. Do not oil. Replace if very dirty or damaged.
3. Clean out the inside of the body and cover.
4. Place the element into the body and put the cover back on..

## IMPORTANT

Do not use petroleum solvents, e.g., kerosene, which will cause cartridge to deteriorate. Do not use pressurized air to clean cartridge. Pressurized air can damage cartridge.

Cyclonic air cleaner  
76-395-04

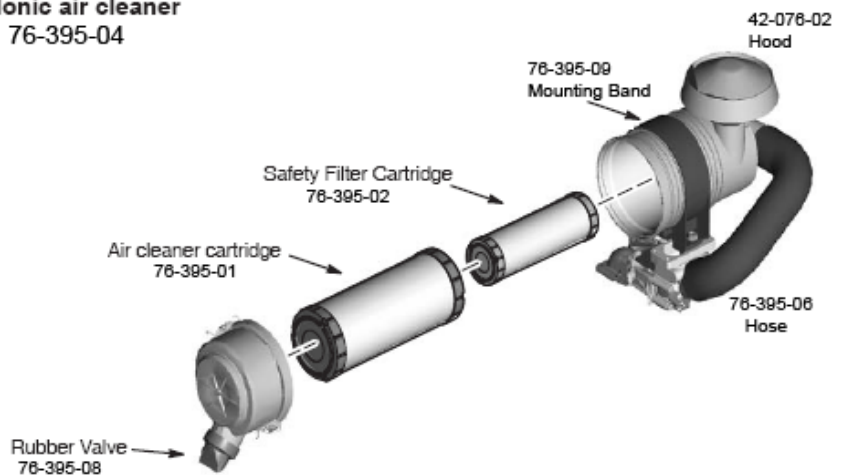

## ENGINE OIL

Change and add oil according to chart below based on air temperature at the time of operation. Do not overfill. Use a high quality detergent oil classified "For Service SJ or higher" oil. Use no special additives with recommended oils. Do not mix oil with gasoline.

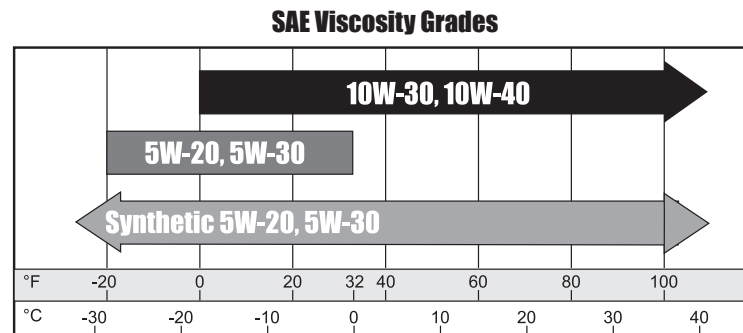

*Starting Temperature Range Anticipated Before Next Oil Change*

## HYDRAULIC OIL

1. Use SAE 10W-30 API Service SJ or higher motor oil.
2. For proper warranty, change oil every 500 hours or annually, which ever is first.
3. Oil level should be 2-2½" (5-6.4cm) from top of the tank when fluid is cold. Do not overfill.
4. After changing oil, run the machine for a few minutes. Check oil level and for leaks.
5. Always use extreme caution when filling hydraulic oil tank or checking level to keep system free of contaminants. Check and service more frequently when operating in extremely cold, hot or dusty conditions.
6. If the natural color of the fluid has become black or smells burnt, it is possible that an overheating problem exists.
7. If fluid becomes milky, water contamination may be a problem.
8. If either of the above conditions happen, change oil immediately after fluid is cool and find the cause. Take fluid level readings when the system is cold.
9. In extreme temperatures you can use straight weight oil. We recommend SAE 30W API Service SG when hot (above 90°F (33°C)) and SAE 10W API Service SJ or higher when cold (below 32°F (0°C) ambient temperature. Use either motor oil or hydraulic oil, but do not mix.
10. Oil being added to the system must be the same as what is already in the tank. Mark the tank fill area as to which type you put in.

## TIRE PRESSURE

Caution must be used when inflating a low tire to recommended pressure. Over inflating can cause tires to explode. All tires should be 20 psi (1.4bar). Improper inflation will reduce tire life considerably.

## WHEEL MOUNTING PROCEDURE

1. Set park brake. Turn machine off and remove key.
2. Block wheel on opposite corner.
3. Loosen nuts slightly on wheel to be removed.
4. Jack up machine being careful not to damage underside of machine.
5. Place wheel on hub lining up bolt holes.
6. Torque to 64-74 ft/lb (87-100Nm) using a cross pattern. Re-torque after first 10 hours and every 200 hours thereafter.
7. Lower machine to ground and remove blocks and jack.

# MAINTENANCE

## BATTERY

Batteries normally produce explosive gases which can cause personal injury. Do not allow flames, sparks or any ignited object to come near the battery. When charging or working near battery, always shield your eyes and always provide proper ventilation.

Battery cable should be disconnected before using "Fast Charge".

Charge battery at 15 amps for 10 minutes or 7 amps for 30 minutes. Do not exceed the recommended charging rate. If electrolyte starts boiling over, decrease charging.

Always remove grounded (-) battery clamp first and replace it last. Avoid hazards by:

1. Filling batteries in well-ventilated areas.
2. Wear eye protection and rubber gloves.
3. Avoid breathing fumes when electrolyte is added.
4. Avoid spilling or dripping electrolyte.

### ⚠ WARNING

**Battery Electrolyte is an acidic solution and should be handled with care. If electrolyte is splashed on any part of your body, flush all contact areas immediately with liberal amounts of water. Get medical attention immediately.**

### ⚠ WARNING

**Use of booster battery and jumper cables. Particular care should be used when connecting a booster battery. Use proper polarity in order to prevent sparks.**

### TO JUMP START (NEGATIVE GROUNDED BATTERY):

1. Shield eyes.
2. Connect ends of one cable to positive (+) terminals of each battery, first (A) then (B).
3. Connect one end of other cable to negative (-) terminal of "good" battery (C).
4. Connect other end of cable (D) to engine block on unit being started (NOT to negative (-) terminal of battery)

To prevent damage to other electrical components on unit being started, make certain that engine is at idle speed before disconnecting jumper cables.

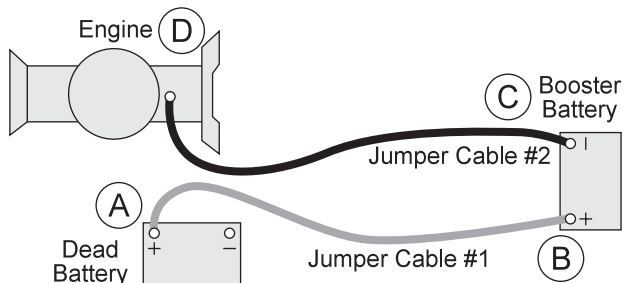

# STORAGE

If the engine will be out of service for two or more months, use the following storage procedure.

1. Clean the exterior surfaces of the engine.
2. Change the oil and filter while the engine is still warm from operation.
3. The fuel system must be completely emptied, or the gasoline must be treated with a stabilizer to prevent deterioration.

If you choose to use a stabilizer, follow manufacturers recommendations, and add the correct amount for the capacity of fuel system. Fill fuel tank with clean, fresh gasoline. Run engine for 2-3 minutes to get stabilized fuel into carburetor. Close fuel shut-off valve when unit is being stored or transported.

To empty the system, drain fuel tank and carburetor, or run engine until tank and system are empty.

4. Remove the spark plugs. Add one tablespoon of engine oil into each spark plug hole. Install plugs, but do not connect the plug leads. Crank the engine two or three revolutions.
5. Store machine in a clean, dry place.

**⚠ CAUTION**

Before servicing or making adjustments to the machine, stop engine, set park break, block wheels and remove key from ignition.

**⚠ IMPORTANT**

Follow all procedures and **ONLY** use parts prescribed by the manufacturer. Read the engine manual before maintenance.

The suggested maintenance checklist is not offered as a replacement for the manufacturer's engine manual but as a supplement. You must adhere to the guidelines established by the manufacturer for warranty coverage. In adverse conditions such as dirt, mud or extreme temperatures, maintenance should be more frequent.

Maintenance Service Interval	Maintenance Procedure
After the first 8 operating hours	Torque the wheel lug nuts. (64-74 ft/lb (87-100 Nm)) Change the engine oil filter.
Before each use daily	Check the engine oil level. Clean area around muffler and controls. Check the hydraulic fluid level. Check the tire pressure. Check condition of hydraulic hoses and fittings. Inspect and clean the machine.
After the first 50 hours	Change Hydraulic Oil Filter.
Every 100 hours	Clean or change air filter. <sup>1&amp;2</sup> Clean pre-cleaner. <sup>1</sup> Change engine oil and filter. Replace spark plug . Lubricate machine. Clean or change remote air cleaner. Check the battery fluid level and cable connections.. Service exhaust system. Check belt tension .
Every 250 hours	Check engine valve clearance and adjust if necessary. Check idle speed. Clean battery terminals. Change hydraulic oil filter. Torque the wheel lug nuts. (64-74 ft/lb (87-100 Nm))
Every 500 hours or yearly	Change fuel filter. Change hydraulic oil and filter. Clean oil cooler fins. <sup>1</sup> Replace air filter <sup>2</sup> Replace fuel filter Clean air cooling system. <sup>1</sup> Check safety filter in remote air cleaner.

<sup>1</sup> In dusty conditions or when airborne debris is present, clean more often.

<sup>2</sup> Every third air filter change, replace the inner safety filter.

# END USER SERVICE CHART

Duplicate this page for routine use.

Service

Maintenance Check Item	For the week of:						
	Mon	Tues.	Wed.	Thurs.	Fri.	Sat.	Sun.
Check the Safety Seat Switch							
Check Steering Operation							
Check the fuel level							
Check the engine oil level.							
Clean the air filter							
Clean the engine cooling fins.							
Check for unusual engine noises							
Check the hydraulic oil level							
Check hydraulic hoses and fittings for damage							
Check for fluid leaks.							
Check the tire pressure							
Check the Instrumentation							
Inspect electrical system for frayed wires							
Check park brake adjustment							
Change oil filter.							
Change oil.							
Lubricate Machine							
Ensure all warning decals are intact.							

Areas of Concern		
Inspection Performed by:		
Item	Date	Information

## WHEEL CREEP

"Creep" is when the engine is running and hydrostatic transmission is in neutral, but due to inadequate alignment, wheels still move. Do the following procedure to stop this motion.

1. Lift up and support machine so rear wheels are off the ground and can turn freely.
2. In the engine compartment, the hydrostatic transmission is on the left side. The shift arm (D) is under the pump and comes out the side. The idler arm (B) has a bearing that runs in the notch of the shift arm. Loosen bolt (A).
3. With engine running, move bearing (B) so it centers on the shift arm (D) and 'wheel creep' stops.
4. Tighten all fasteners and test by using foot pedal linkage to see that 'creep' is removed.
5. Turn engine off and lower machine.

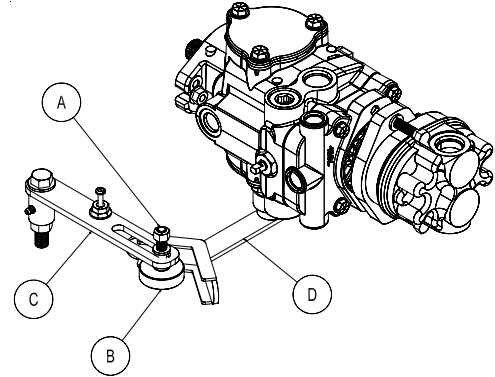

## SPRAY PUMP WITH BELT

Located to the right of the engine. The belt should have approximately  $\frac{1}{2}$ " (13mm) of deflection in the center of the top strand. Loosen and tighten the  $\frac{5}{16}$ " -18 x  $1\frac{1}{4}$ " set screw located on the foot of the pump mount.

## PARK BRAKE

Turn knob clockwise on end of park brake to tighten. Turn it counter clockwise to loosen. If finer adjustment is needed turn clevis on brake cable to adjust length of cable.

## MASTER BOOM SWITCH (FOOT SWITCH)

The master boom switch, located on the left floorboard is used to override the master switch on the computer console of the spray systems. By pushing down it will turn on/off the booms.

## GROUND SPEED CONTROL (FOOT SWITCH)

The ground speed control does not work the same as an automotive type cruise. The ground speed control is located on the center floorboard and is used to lock forward speed.

## TO ENGAGE:

1. Flip rocker switch 'On' (green light).
2. Obtain desired speed with foot pedal.
3. Step on foot switch to lock speed.
4. Push foot switch again to disengage.

## SPRAY BOSS CONTROL - ORANGE

Engages and disengages speed boss. Forward is engage and all the way back is disengage. When the lever is engaged it sets a stop for the accelerator. The accelerator pedal must be used to maintain this speed. To adjust speed use the knob on the end of the lever, counter clockwise increases speed and clockwise decreases speed. Disengage the lever and you will have full accelerator pedal range.

# WIRING DIAGRAM

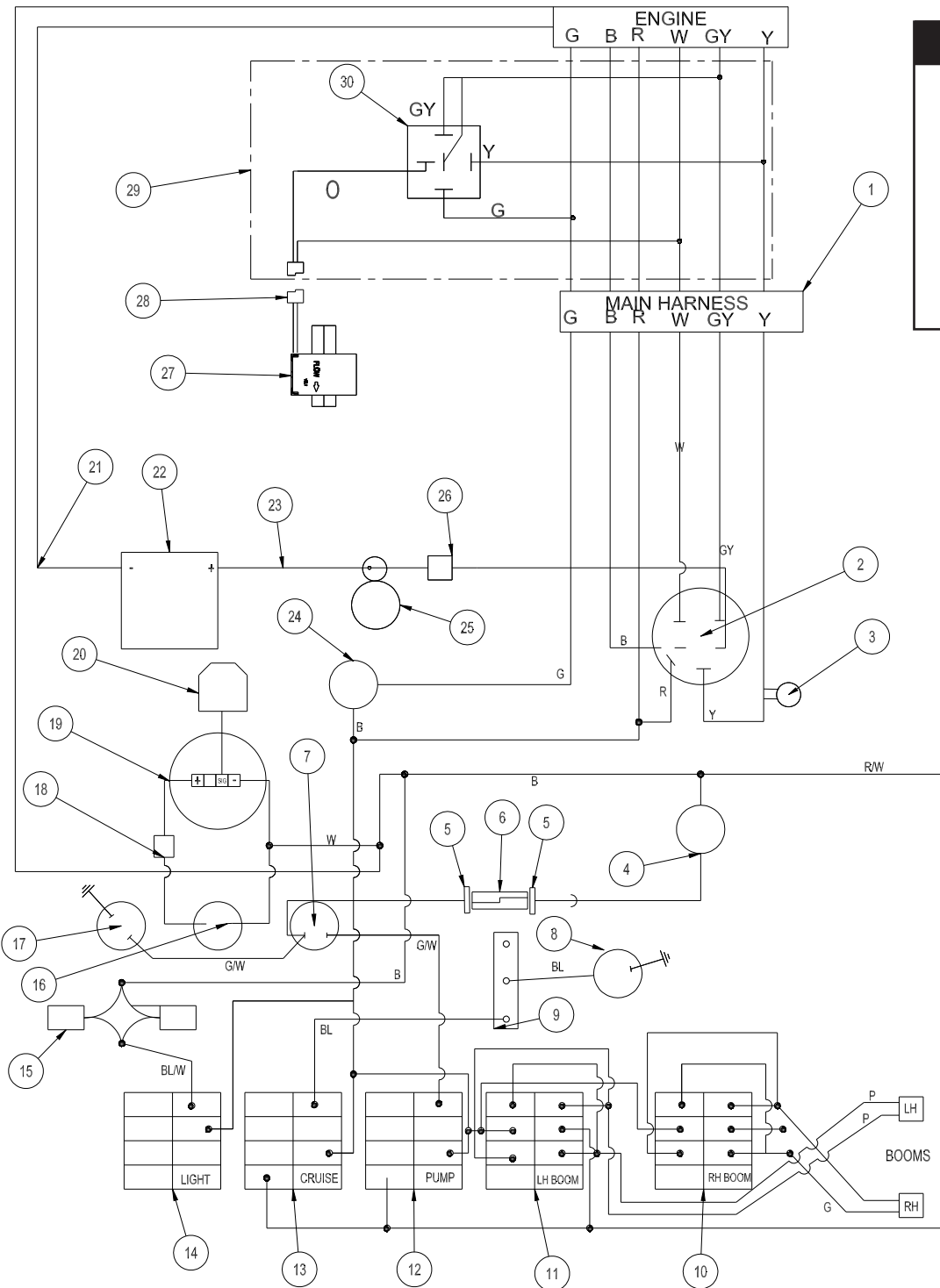

Color Code Chart	
Bl	Blue
Br	Brown
Y	Yellow
G	Green
O	Orange
R	Red
B	Black
GY	Gray
W	White

Diagrams

Use dielectric grease on all electrical connections.



# WIRING PARTS LIST

REF#	PART#	DESCRIPTION	QUANTITY
1	20-579	Wire Harness	1
2	13-488	Key Switch	1
3	14-292	Seat Switch	1
4	77-207	Buzzer	1
5	9017	Terminal	2
	9018	Seal	2
6	9016	Weather Pack	1
7	33-480	Pressure Switch	1
8	33-084	Magnetic Coil	1
9	33-509	Master Boom Switch	1
10	Right Boom		
	15-725	Mount Panel End	1
	15-727	Rocker - No light	1
	15-728	Centering Switch, Momentary, On-Off-On	1
11	Left Boom		
	15-729	Mount Panel Middle	1
	15-728	Centering Switch, Momentary, On-Off-On	1
	15-727	Rocker - No light	1
12	Pump		
	15-729	Mount Panel Middle	1
	15-726	Lighted Switch	1
	15-731	Rocker - Amber	1
13	Cruise		
	15-729	Mount Panel Middle	1
	15-726	Lighted Switch	1
	15-732	Rocker - Green	1
14	Lights		
	15-725	Mount Panel End	1
	15-782	Non-Lighted Switch, On-None-Off	1
	15-727	Rocker - No light	1
15	32-014	Lights	2
16	12-804	Hour Meter	1
17	16-998	Spray Pump	1
18	20-733	10AMP Circuit Breaker	1
	8877	Red Circuit Breaker Boot	1
19	20-730	GPS Speedometer	1
20		GPS Antenna (part of speedometer)	1
21	48-147	Negative Battery Cable	1
22	33-216	Battery	1
23	50-323	Red Battery Cable	1
24	50-359	Oil Temperature Light	1
25		Solenoid	1
26	77-261	40 Amp Circuit Breaker	1
	8977	Red Circuit Breaker Boot	1
27	76-471	Electric Fuel Pump	1
28	15-814	Weather Pack	1
	9018	Seals	2
	9017	Male Terminal	2
29	76-633	Fuel Pump Wlre Harness	1
30	30-042-06	Relay	1

# HYDRAULIC DIAGRAM

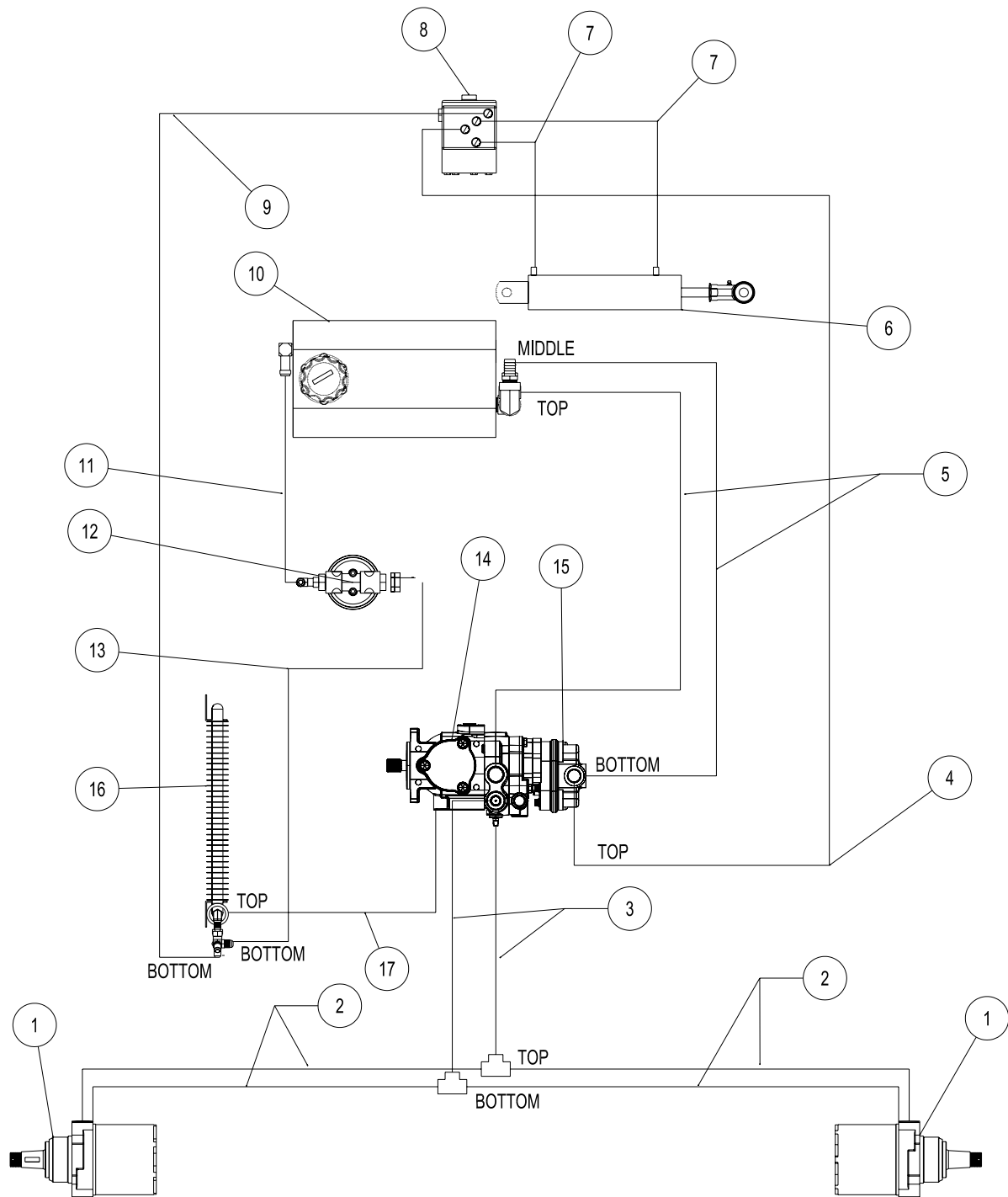

Diagrams

## HYDRAULIC DIAGRAM PARTS LIST

REF#	PART#	DESCRIPTION	QUANTITY
1	76-238	Wheel Motor	2
2	15-681	Hydraulic Hose, 23"	4
3	15-682	Hydraulic Hose, 46 <sup>3</sup> / <sub>4</sub> "	2
4	15-685	Hydraulic Hose, 101"	1
5	8832-33	<sup>3</sup> / <sub>4</sub> " Suction Hose x 33"	2
	18-040	Hose Clamp	4
6	15-839	Hydraulic Cylinder	1
	14-531	Seal Kit	1
7	15-687	Hydraulic Hose, 75 <sup>1</sup> / <sub>2</sub> "	2
8	15-301	Orbitrol	1
9	15-686	Hydraulic Hose, 107 <sup>1</sup> / <sub>2</sub> "	1
10	60-473	Hydraulic Oil tank	1
11	8917-26	<sup>3</sup> / <sub>8</sub> " Suction Hose x 26"	1
	18-040	Hose Clamp	2
12	26-016	Oil Filter	1
	23-031	Replacement Filter	1
13	15-683	Hydraulic Hose, 43 <sup>3</sup> / <sub>4</sub> "	1
14	76-482	Hydrostatic Pump	1
15	76-197	Gear Pump	1
16	15-624	Cooler	1
17	15-684	Hydraulic Hose, 58"	1

## PUMP DISPLACEMENT

### 76-398 Hydrostatic Pump

Displacement	Variable to 1.44 in <sup>3</sup> /R (23.6 cm <sup>3</sup> /R) 22.44 gpm (84.94 lpm) at 3600 rpm
Max Operating Speed	3600 rpm
Rated Pressure	3000 psi (206.8 bar)
Max Pressure	5000 psi (344.7 bar)
Max Inlet Vacuum	6 in Hg (.203 bar)
Max Inlet Temperature	225°F (107°C)
Max Allowable Case Pressure	25 psi (1.72 bar)

**76-197 Gear Pump Displacement .40 in<sup>3</sup>/R (6.6 cm<sup>3</sup>/R) 6.23 gpm (25.39 lpm)**

**Over tightened fittings will result in crushing the cone which will create a leak.**

# BODY & FRAME DRAWING

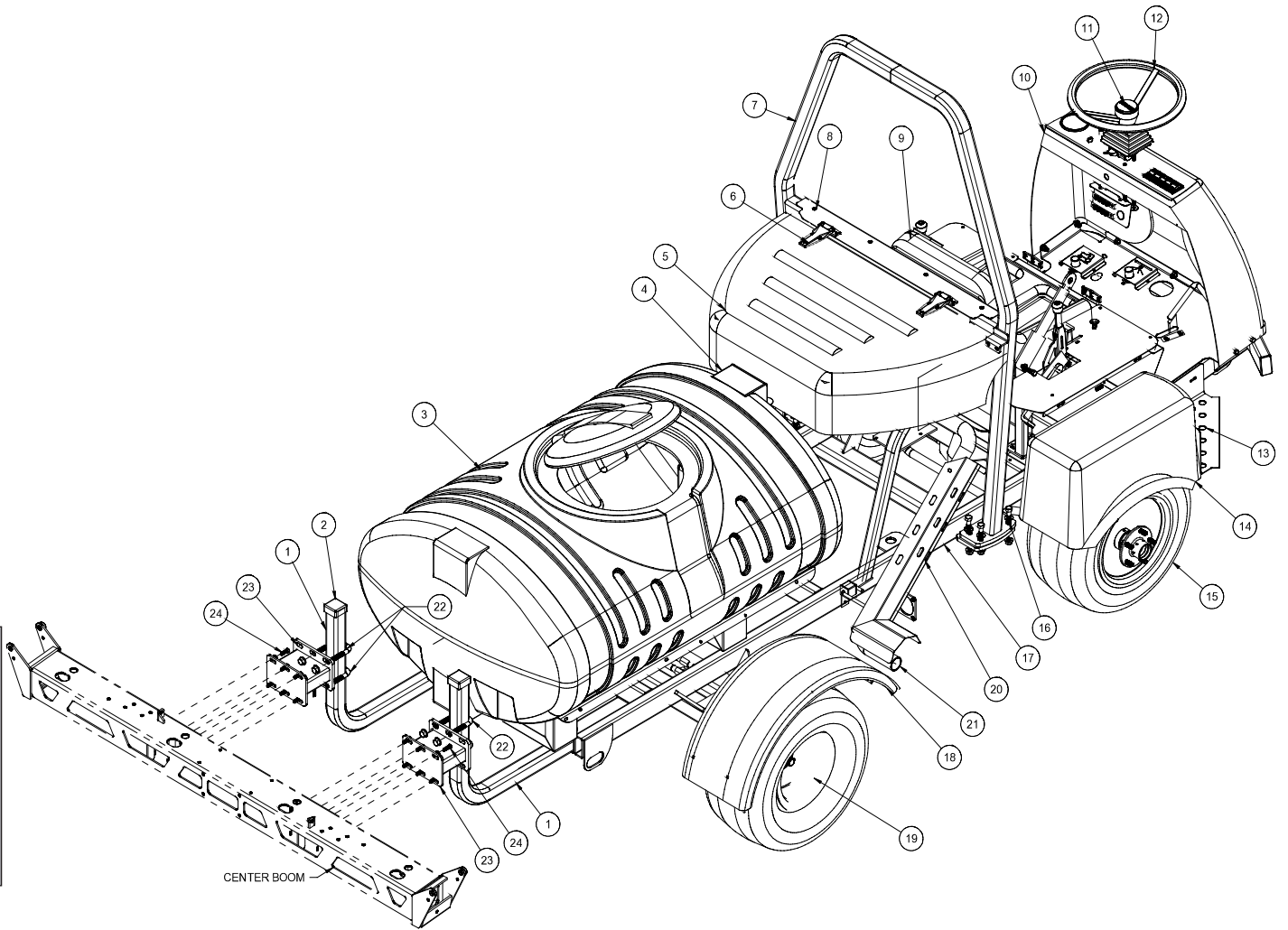

PARTS

## BODY & FRAME PARTS LIST

REF#	PART#	DESCRIPTION	QUANTITY
1	17-615	Boom Support Tube	2
2	16-557	Square Cap	2
3	15-897	Spray Tank	1
	14-532	Lid	1
	16-169	Strainer Basket	1
4	15-787	Hood Support	1
	50-081	Rubber Bumper	1
	HNTL-38-16	Nylon Lock Nut, $\frac{3}{8}$ - 16	1
5	15-765	Rear Hood (fiberglass)	1
6	27-055	Hinge	2
	HSM-10-32-063	Machine Screw, #10 - 32 x $\frac{5}{8}$	6
	HSM-10-32-100	Machine Screw, #10 - 32 x 1	6
	HNFL-10-32	Flange Whiz-loc Nut, #10 - 32	12
7	15-762	Roll Bar	1
8	15-756	Back Panel	1
9	14-294	Seat Kit	1
	14-800	Seat Rail Set	1
	HSP-1260-340-250	Seat Spacers	4
10	15-822	Nose Cone (fiberglass)	1
	15-672	Decal, Dash Panel	1
11	13-726	Steering Wheel Cap	1
	27-077	Decal, Smithco	1
12	13-718	Steering Wheel	1
13	15-751	RH Step	1
	15-752	LH Step	1
14	15-823	RH Front Fender	1
	15-767	LH Front Fender	1
15	16-857	Tire and Wheel	2
	16-857-01	Tire, 20 x 10.00 - 10NHS 4 Ply	2
	42-161-02	Wheel	2
16	HB-12-13-200	Hex Bolt, $\frac{1}{2}$ - 13 x 2	8
	HW-12	Flat Washer, $\frac{1}{2}$	8
	HNFL-12-13	Flange Whiz-loc Nut, $\frac{1}{2}$ - 13	8
17	15-875	Main Frame	1
18	10-168	Rear Fender	2
	10-466	Rear Fender Bracket	4
19	16-225	Tire and Wheel	2
	16-225-01	Tire, 24 x 13.00 - 12NHS 4 Ply	2
	16-225-02	Wheel	2
20	17-566	Tailpipe Guard	1
21	17-565	Tailpipe	1
22	20-555	U-bolt	4
	HNFL-12-13	Flange Whiz-loc Nut, $\frac{1}{2}$ - 13	8
23	17-614	Boom Spacer	2
24	HB-516-18-100	Hex Bolt, $\frac{5}{16}$ - 18 x 1	12
	HW-516	Flat Washer, $\frac{5}{16}$	12
	HNFL-516-18	Flange Whiz-loc Nut, $\frac{5}{16}$ - 18	12



# NOSE CONE DRAWING

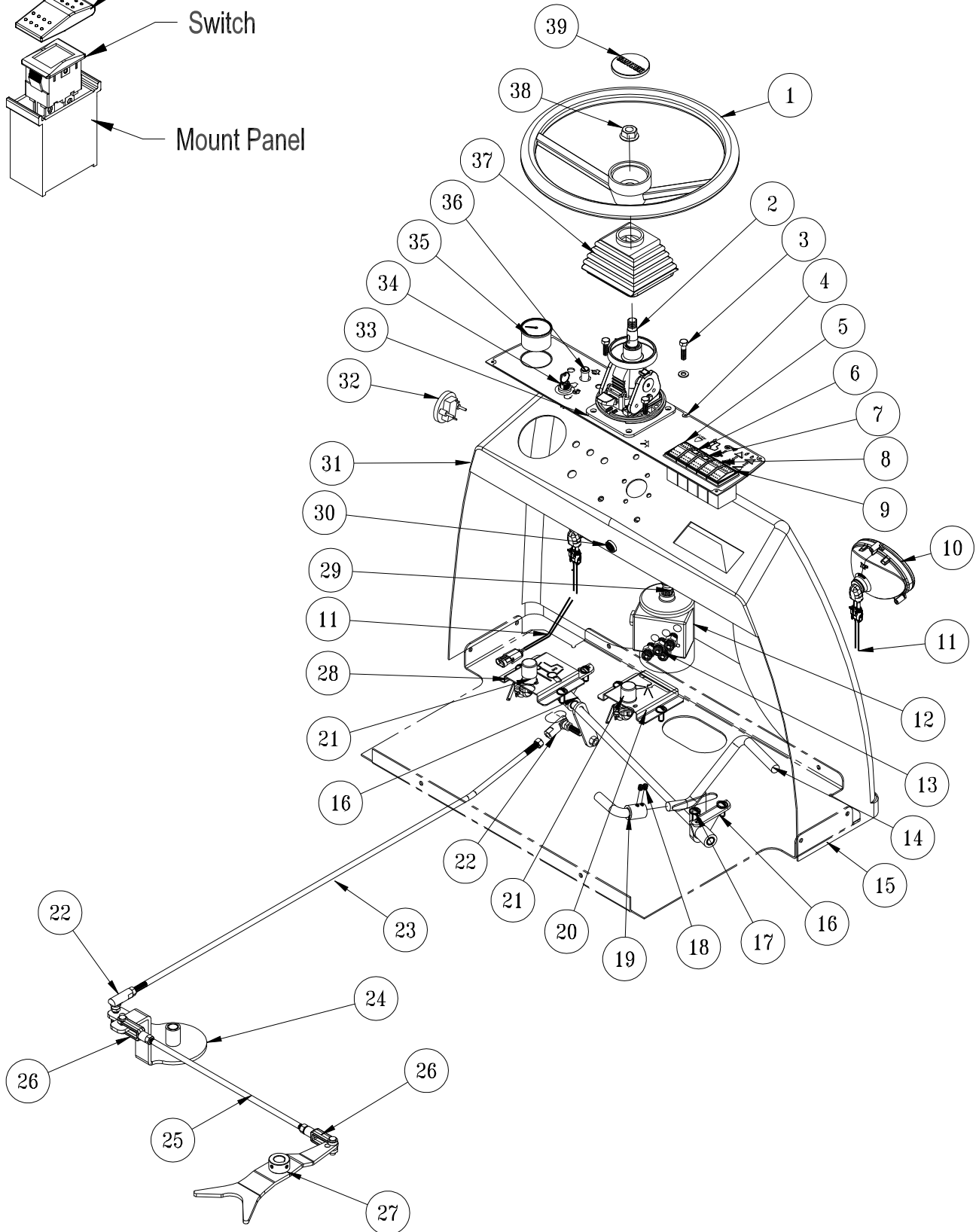
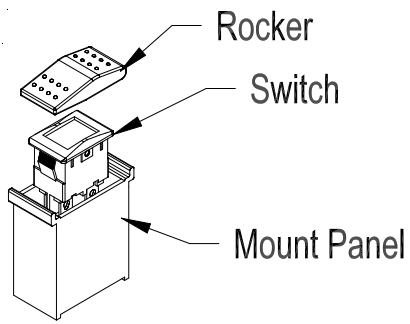

PARTS

# NOSE CONE PARTS LIST

REF#	PART#	DESCRIPTION	QUANTITY
1	13-718	Steering Wheel	1
2	76-362	Tilt Steering Column	1
	HWK-316-075	Woodruff Key, $\frac{3}{16}$ X $\frac{3}{4}$ (comes with 76-362)	1
3	HB-516-18-125	Hex Bolt $\frac{5}{16}$ - 18 x $1\frac{1}{4}$	2
	HB-516-18-150	Hex Bolt, $\frac{5}{16}$ - 18 x $1\frac{1}{2}$	2
4	15-886	Dash Panel	1
	15-672	Decal, Dashboard 1750	1
5	Lights		
	15-725	Panel Mount End	1
	15-727	Rocker Switch - No Light	1
	15-782	Non-Lighted Switch Body, On-None-Off	1
6	Cruise		
	15-729	Mount Panel, Middle	1
	15-726	Lighted Switch	1
	15-732	Rocker Switch - Green	1
7	Pump		
	15-729	Mount Panel, Middle	1
	15-726	Lighted Switch	1
	15-731	Rocker Switch - Amber	1
8	Left Boom		
	15-729	Mount Panel, Middle	1
	15-727	Rocker Switch - No Light	1
	15-728	Centering Switch Momentary, On-Off-On	1
9	Right Boom		
	15-725	Panel Mount End	1
	15-727	Rocker Switch - No Light	1
	15-728	Centering Switch Momentary, On-Off-On	1
10	17-524	Oval Headlights	2
11	10-421	Head Light Pigtail	2
12	15-301	Orbitrol	1
13	18-169	Adapter	4
14	15-820	Foot Pedal Assembly	1
	76-299	Pedal Pad	1
15	HSTP-516-18-100	Machine Screw, $\frac{5}{16}$ - 18 x 1	7
	HNFL-516-18	Flange Whiz-loc Nut, $\frac{5}{16}$ - 18	7
16	76-296	Pedal Mount	2
17	HSTP-516-18-075	Machine Screw, $\frac{5}{16}$ - 18 x $\frac{3}{4}$	4
	HNFL-516-18	Flange Whiz-loc Nut, $\frac{5}{16}$ - 18	4
18	HSSHS-516-18-038	Socket Head Set Screw, $\frac{5}{16}$ - 18	2
19	15-821	Reverse Pedal	1
	76-332	Pedal Pad	1
20	15-758	Spray Switch Plate (1752 only)	1
	HBM-6-1-16	Metric Hex Bolt, #6 -1 x 16	2
21	33-509	Master Boom Switch (1752 only)	2
	HSM-10-32-063	Machine Screw, #10-32 x $\frac{5}{8}$	4
	HNFL-10-32	Flange Whiz-loc Nut, #10 - 32	4
22	21-173	Ball Joint, $\frac{3}{8}$ - 24	2
	HN-38-24	Hex Nut, $\frac{3}{8}$ - 24	4
23	15-761	Long Foot Pedal Rod	1
24	15-692	Pedal Relay	1

(Continued on next page)

# NOSE CONE DRAWING

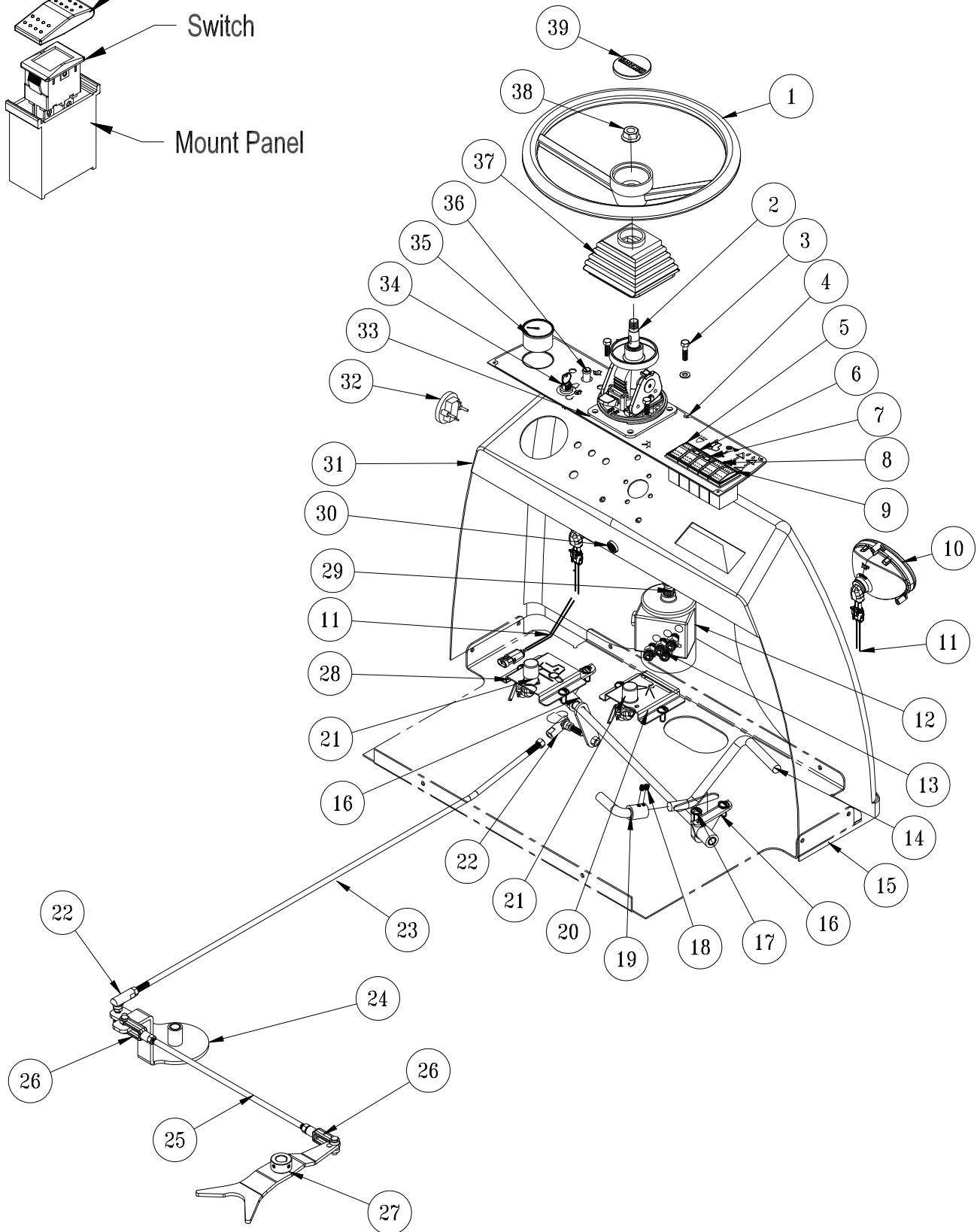
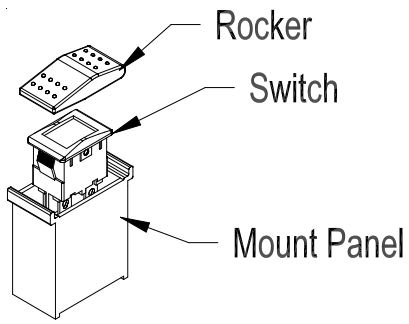

PARTS



## NOSE CONE PARTS LIST

REF#	PART#	DESCRIPTION	QUANTITY
25	15-852	Shift Rod	1
26	21-351	Linkage Yoke	2
	HN-38-24	Hex Nut, $\frac{3}{8}$ - 24	2
	HCP-38-113	Clevis Pin, $\frac{3}{8}$ x $1\frac{1}{8}$	2
	HP-18-075	Cotter Pin, $\frac{1}{8}$ x $\frac{3}{4}$	2
27	20-652	Shift Arm	1
28	15-757	Cruise Switch Plate	1
	HBM-6-1-16	Metric Hex Bolt, #6 -1 x 16	2
29	48-187	Stub Shaft	1
30	77-207	Buzzer	1
31	15-822	Nose Cone	1
	50-400	Rubber Grommet	1
32	12-804	Hour Meter	1
33	15-844	Steering Shim	1
34	13-488	Ignition Switch	1
	15-784	Ignition Jumper Wire	1
35	20-730	Speedometer	1
36	50-359	Oil Indicator Light	1
37	76-364	Square Boot (comes with 76-362)	1
38	HNJ-58-18	Jam Nut, $\frac{5}{8}$ - 18 (comes with 76-362)	1
39	13-726	Steering Wheel Cap	1

# FRONT AXLE DRAWING

PARTS

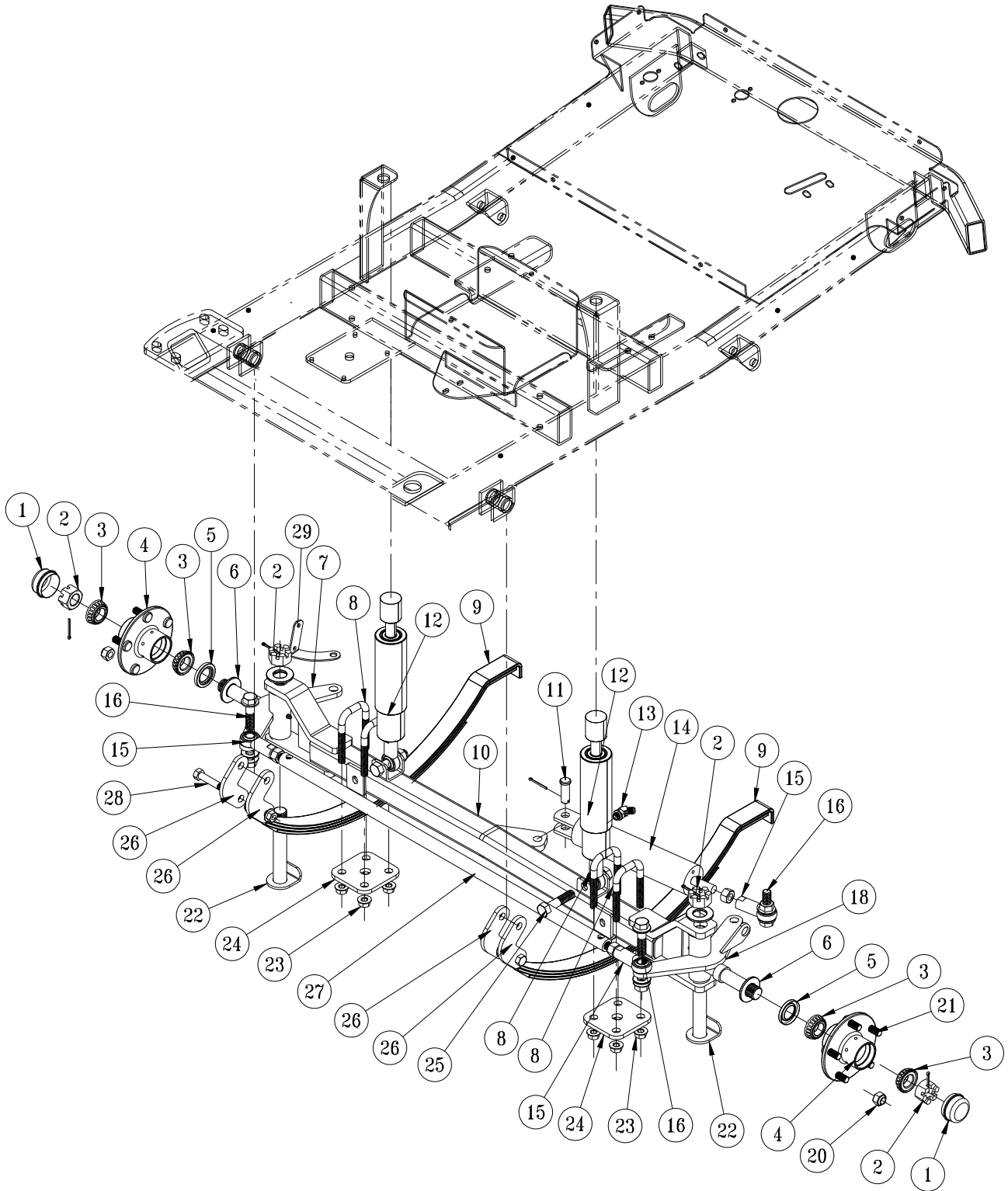

## FRONT AXLE PARTS LIST

REF#	PART#	DESCRIPTION	QUANTITY
1*	80-167	Dust Cap	2
2	HNAR-100-14	Slotted Jam Nut, 1 - 14	4
	HMB-100-10	Machine Bushing, 1 x 10GA	4
	HP-18-150	Cotter Pin, 1/8 - 1 1/2	4
3*	11-043	Bearing with Races	4
4	80-019	Hub (includes all * items)	2
5*	11-041	Oil Seal	2
6	HMB-100-10	Machine Bushing, 1 x 10GA	2
7	15-696	Left Spindle	1
8	20-555	U-bolt	4
9	16-042	Leaf Spring	2
10	15-874	Front Axle	1
11	HCP-58-175	Clevis Pin, 5/8 x 1 3/4	1
	HP-18-100	Cotter Pin, 1/8 x 1	1
12	20-617	Shock Absorber	2
13	18-168	45° Elbow	2
14	15-839	Hydraulic Cylinder	1
	14-531	Cylinder Seal Kit	1
15	18-154	Rod End	3
	HG-14-28-90	Grease Fitting, 1/4 - 28 x 90°	3
	HNJ-58-18	Jam Nut, 5/8 - 18	3
16	HB-58-11-250	Hex Bolt, 5/8 - 11 x 2 1/2	3
	HMB-58-14	Machine Bushing, 5/8 x 14GA	6
	HNTL-58-11	Nylon Lock Nut, 5/8 - 11	3
18	15-695	Right Spindle	1
20*	HNL-12-20	Lug Nut, 1/2 - 20	10
21*	27-022-02	Stud	10
22	16-076	King Pin	2
23	HNFL-12-13	Flange Whiz-loc Nut, 1/2 - 13	8
24	20-538	Spring Mount	2
25	HB-58-11-300	Hex Bolt, 5/8 - 11 x 3	2
	HNTL-58-11	Nylon Lock Nut, 5/8 - 11	2
26	30-253	Spring Shackle	4
27	14-573	Tie Rod	1
28	HB-916-18-325	Hex Bolt, 9/16 - 18 x 3 1/4	4
	HNTL-916-18	Nylon Lock Nut, 9/16 - 18	4
29	15-715	Sensor Bracket (1752 Only)	1



# OIL AND FUEL TANK DRAWING

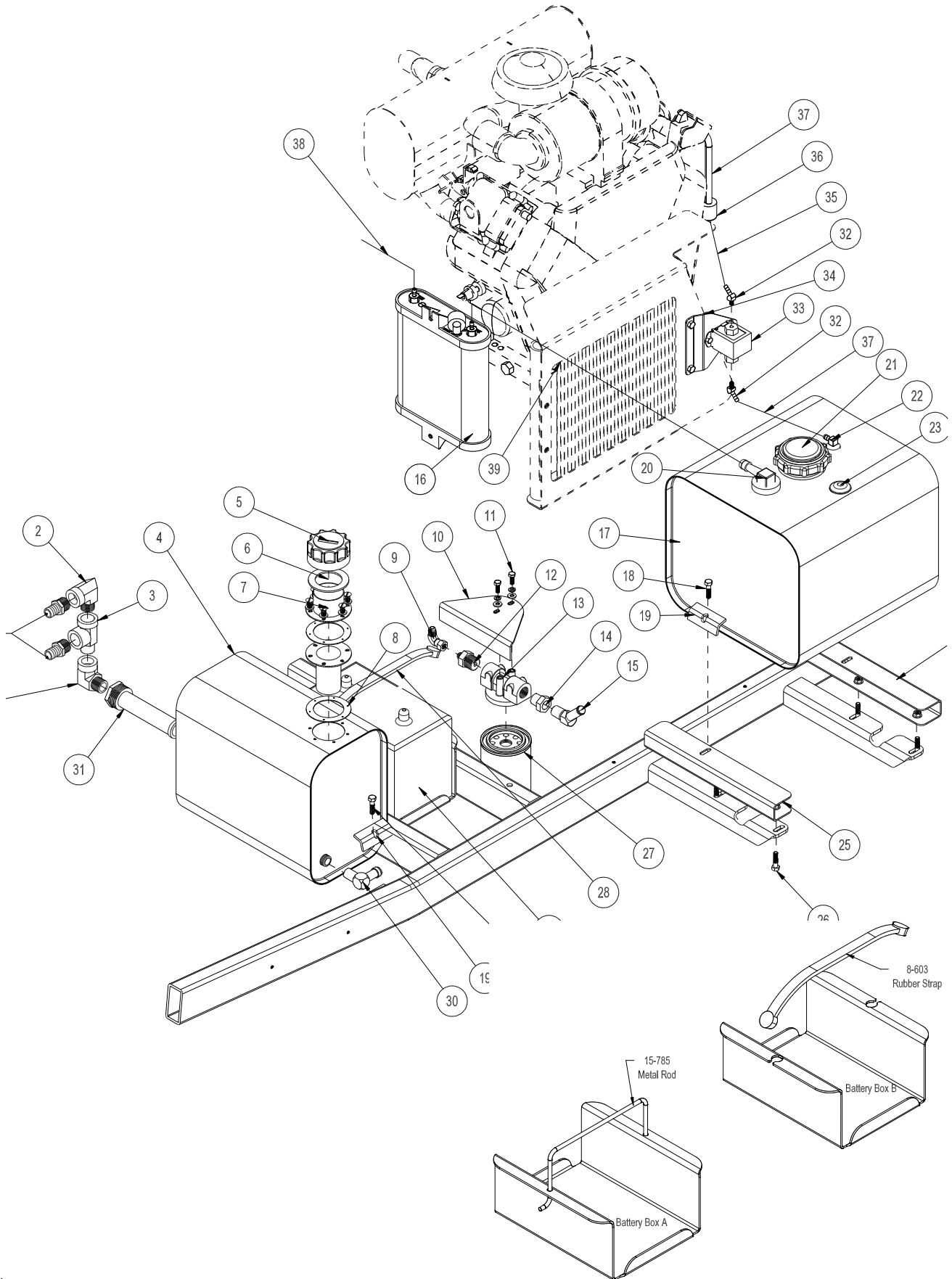

PARTS

# OIL AND FUEL TANK PARTS LIST

REF#	PART#	DESCRIPTION	QUANTITY
1	18-249	Barb Fitting	2
2	18-140	Street Elbow	2
3	18-093	Straight Tee	1
4	60-473	Oil Tank	1
5	13-747	Filler Breather	1
6	13-586-01	Cap Gasket	1
7	13-586-03	Filler Neck	1
	HSM-10-32-063	Machine Screw, 10-32 x <sup>5</sup> / <sub>8</sub>	6
	HWL-10	Lock Washer, #10	6
8	13-586-02	Bottom Gasket	1
9	18-202	Elbow	1
10		Part of Main Frame	
11	HB-14-20-075	Hex Bolt, <sup>1</sup> / <sub>4</sub> - 20 x <sup>3</sup> / <sub>4</sub>	2
	HW-14	Flat Washer, <sup>1</sup> / <sub>4</sub>	2
	HWL-14	Lock Washer, <sup>1</sup> / <sub>4</sub>	2
12	23-183	Male Connector	1
13	26-016	Oil Filter	1
14	18-008	Pipe Thread Reducer	1
15	23-143	Connector	1
16	20-721	1.8l Carbon Canister	1
17	20-692	10 Gallon Gas Tank	1
18	HB-516-18-150	Hex Bolt, <sup>5</sup> / <sub>16</sub> - 18 x 1 <sup>1</sup> / <sub>2</sub>	4
	HW-516	Flat Washer, <sup>5</sup> / <sub>16</sub>	8
	HNFL-516-18	Flange Whiz-loc Nut, <sup>5</sup> / <sub>16</sub> - 18	4
19	75-792	Tank Hold Down	4
20	42-814-05	Rollover Valve	1
	42-814-06	Valve Grommet	1
21	20-694	Cap	1
22	20-692-01	Top Draw	1
	42-814-07	Top Draw Grommet	1
23	20-692-02	Fuel Gauge	1
	20-692-03	Grommet	1
24	17-633	Right Tank Mount	1
25	17-634	Left Tank Mount	1
26	HB-516-18-100	Hex Bolt, <sup>5</sup> / <sub>16</sub> - 18 x 1 <sup>1</sup> / <sub>2</sub>	4
	HNFL-516-18	Flange Whiz-loc Nut, <sup>5</sup> / <sub>16</sub> - 18	4
27	23-031	Replacement Filter	1
28	15-785	Battery Hold Down - Metal Rod	1
	8-603	Battery Hold Down - Rubber Strap	1
29	33-216	Battery	1
30	23-142	Connector	1
31	60-213	Strainer	1
32	8800-29	Fuel Line, <sup>1</sup> / <sub>4</sub> " x 29(fuel pump to Top Draw)	1
	18-186	Hose Clamp	2
33	18-420	45° Hose Barb	2
34	76-471	Electric Fuel Pump	1
35	15-905	Pump Mount Plate	1
36	8800-10	Fuel Line, <sup>1</sup> / <sub>4</sub> " x 10(fuel pump to engien filter)	1
	18-186	Hose Clamp	2
37	50-403	In-line Fuel Filter	1
38	8800-14	Fuel Line, <sup>1</sup> / <sub>4</sub> " x 14(fuel pump to Top Draw)	1
	18-186	Hose Clamp	2
39	8800-48	Fuel Line, <sup>1</sup> / <sub>4</sub> " x 48" (Engine purge Line to Canister)	1
	18-186	Hose Clamp	2
40	8800-70	Fuel Line, <sup>1</sup> / <sub>4</sub> " x 70" (Canister to Rollover Valve)	1
	18-186	Hose Clamp	2

# SEAT PANEL DRAWING

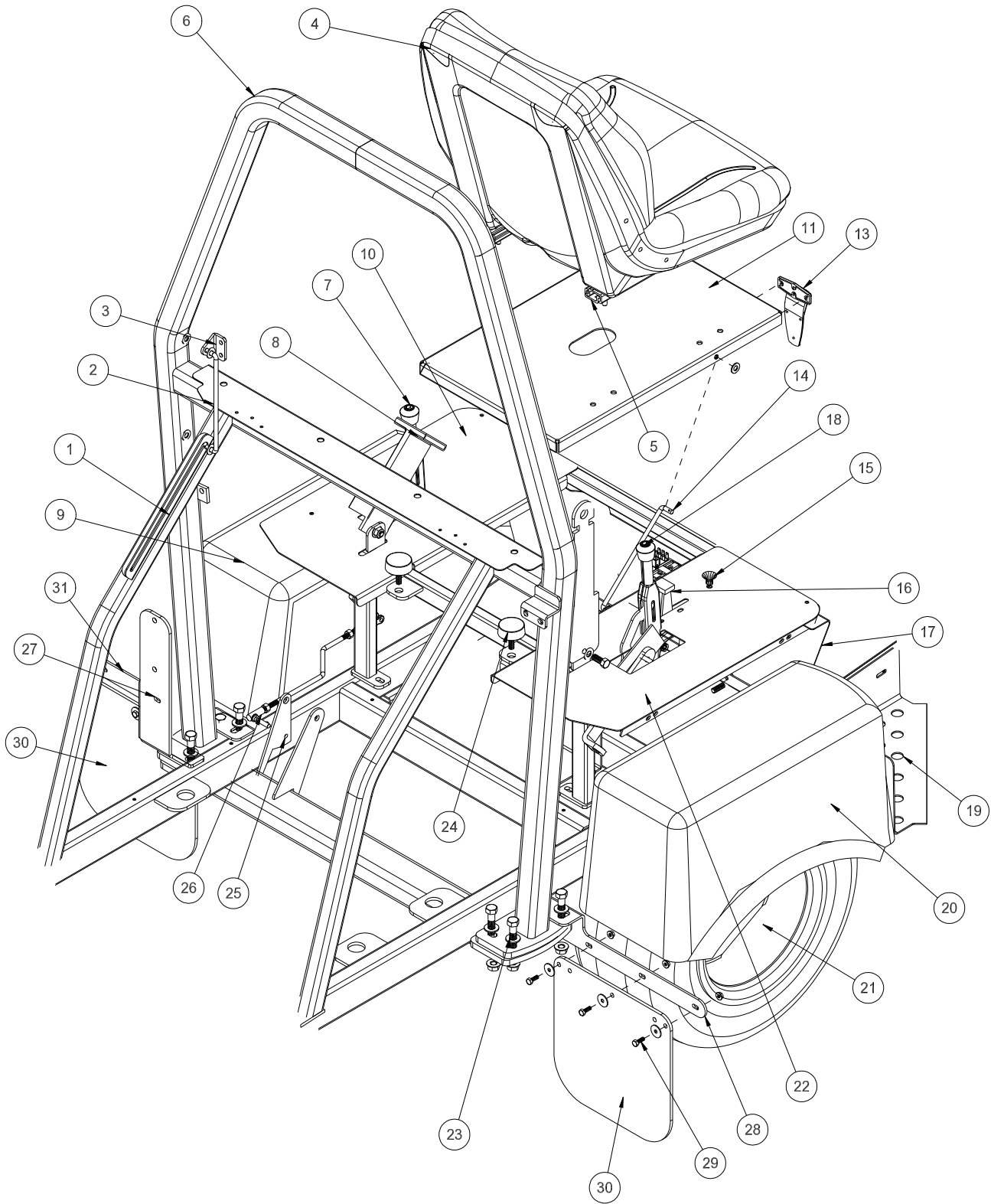

PARTS

## SEAT PANEL PARTS LIST

REF#	PART#	DESCRIPTION	QUANTITY
1	15-723	Hood Latch	1
2	15-786	Hood Rod	1
	HW-38	Flat Washer, $\frac{3}{8}$	4
	HP-18-075	Cotter Pin, $\frac{1}{8} \times \frac{3}{4}$	2
3	10-211	Hood Rod Mount	1
4	14-294	Seat Kit	1
5	14-800	Seat Rail Set	1
	HSP-1260-340-250	Seat Spacer	4
6	15-762	Roll Bar	1
7	60-106	Spray Boss Lever	1
8	76-198-03	Seat Belt	1
	HB-716-14-100	Hex Bolt, $\frac{7}{16}$ - 14 x 1	2
	HW-716	Flat Washer, $\frac{7}{16}$	2
	HNTL-716-14	Nylon Lock Nut, $\frac{7}{16}$ - 14	2
9	15-767	Front Fender - LH	1
	15-781	Plastic Cup Holder	1
10	15-713	Side Panel - LH	1
11	15-714	Seat Panel	1
13	27-055	Hinge	2
	HSM-10-32-063	Machine Screw, #10-32 x $\frac{5}{8}$	12
	HN-10-32	Hex Nut, #10 - 32	12
14	15-786	Hood Rod	1
	HW-38	Flat Washer, $\frac{3}{8}$	4
	HP-18-075	Cotter Pin, $\frac{1}{8} \times \frac{3}{4}$	2
15	80-020	Choke Cable	1
16	34-160	Throttle Cable	1
	34-160-01	Inner Cable	1
17	15-711	Front Panel	1
	HBFL-516-18-075	Flange Whiz-loc Bolt, $\frac{5}{16}$ - 18 x $\frac{3}{4}$	2
	HNFL-516-18	Flange Whiz-loc Nut, $\frac{5}{16}$ - 18	2
18	60-106	Park Brake	1
19	15-751	Step - RH	1
	15-752	Step - LH	1
20	15-823	Front Fender - RH	1
21	16-857	Tire and Wheel	2
	16-857-01	Tire, 20 x 10.00 - 10NHS 4 Ply	2
	16-857-02	Wheel	2
22	15-712	Side Panel - RH	1
23	HB-12-13-200	Hex Bolt, $\frac{1}{2}$ - 13 x 2	8
	HW-12	Flat Washer, $\frac{1}{2}$	8
	HNFL-12-13	Flange Whiz-loc Nut, $\frac{1}{2}$ - 13	8
24	50-081	Rubber Insulator	2
	HNTL-38-16	Nylon Lock Nut, $\frac{3}{8}$ - 16	2
25	15-706	Speed Boss Arm	1
26	15-707	Spray Boss Linkage	1
	11-100	Linkage Yolk	1
	21-462	Ball Joint	1
27	15-708	Valve Mount	1
28	30-291	RH Mud Flap Bracket	1
29	HB-14-20-075	Hex Bolt, $\frac{1}{4}$ - 20 x $\frac{3}{4}$	6
	HWF-14	Fender Washer, $\frac{1}{4}$	6
	HNFL-14-20	Flange Whiz-loc Nut, $\frac{1}{4}$ - 20	6
30	20-659	Mud Flap	2
31	30-292	LH Mud Flap Bracket	1

# ENGINE, PUMPS AND EXHAUST DRAWING

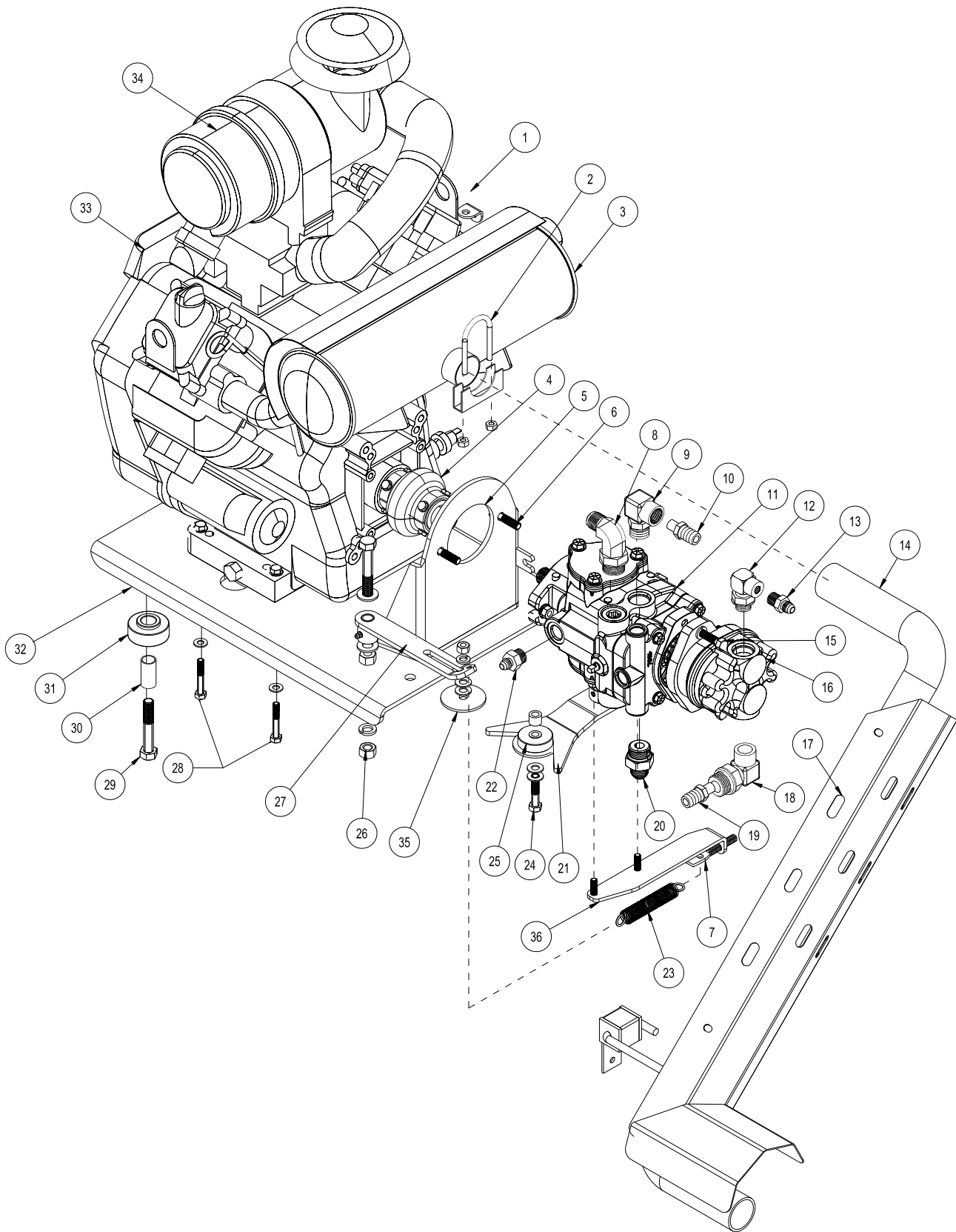

PARTS



## ENGINE, PUMPS AND EXHAUST PARTS LIST

REF#	PART#	DESCRIPTION	QUANTITY
1	76-270	Cable Mount	1
	HB-516-24-075	Hex Bolt, $\frac{5}{16}$ - 24 x $\frac{3}{4}$	1
	HWL-516	Lock Washer, $\frac{5}{16}$	1
2	76-447	Muffler	1
3	50-394	Muffler Clamp	1
4	76-465	Pump Coupling Complete	1
	76-466	$\frac{7}{8}$ Coupling Half	1
	76-467	$1\frac{1}{8}$ Coupling Half	1
	76-468	Sleeve M42	1
5	15-774	Pump Mount	1
	HB-38-16-125	Hex Bolt, $\frac{3}{8}$ - 16 x $1\frac{1}{4}$	2
	HW-38	Flat Washer, $\frac{3}{8}$	2
	HNTL-38-16	Nylon Lock Nut, $\frac{3}{8}$ -16	2
6	HB-38-16-150	Hex Bolt, $\frac{3}{8}$ - 16 x $1\frac{1}{2}$	2
	HW-516	Flat Washer, $\frac{5}{16}$	2
	HNTL-38-16	Nylon Lock Nut, $\frac{3}{8}$ - 16	2
7	42-604	Spade Hex Bolt, $\frac{3}{8}$ "	1
8	18-204	Elbow	1
9	23-130	Elbow	1
10	18-133	Hose Barb	1
11	76-482	Hydrostat Pump	1
	23-145	O-ring	1
12	23-129	Elbow	1
13	23-188	Male Connector	1
14	17-566	Tailpipe	1
	HB-516-18-200	Hex Bolt, $\frac{5}{16}$ - 18 x 2	1
	HNFL-516-18	Flange Whiz-loc Nut $\frac{5}{16}$ - 16	1
15	HB-38-16-125	Hex Bolt $\frac{3}{8}$ - 16 X $1\frac{1}{4}$	2
	HNFL-38-16	Flange Whiz-loc Nut, $\frac{3}{8}$ - 16	2
16	76-197	Gear Pump	1
17	17-565	Tailpipe Guard	1
	HB-516-18-075	Hex Bolt, $\frac{5}{16}$ - 18 x $\frac{3}{4}$	4
	HNTL-516-18	Nylon Lock Nut, $\frac{5}{16}$ - 18	4
18	23-133	Adjustable Elbow, 90°	1
19	18-133	Hose Barb	1
20	15-702	Adapter	1
21	20-652	Shift Arm	1
	HSSHS-14-20-025	Set Screw, $\frac{1}{4}$ - 20 x $\frac{1}{4}$	1
22	18-241	Straight Thread Connector	1
23	21-445	Spring	1
24	HB-38-16-175	Hex Bolt, $\frac{3}{8}$ - 16 x $1\frac{3}{4}$	1
	HW-38	Flat Washer, $\frac{3}{8}$	5
	HN-38-16	Hex Nut, $\frac{3}{8}$ - 16	1
	HWL-38	Lock Washer, $\frac{3}{8}$	1
25	14-266	Ball Bearing	1
	18-270	Oilite Bushing	1
26	HB-12-13-300	Hex Bolt, $\frac{1}{2}$ - 13 x 3	1
	HN-12-13	Hex Nut, $\frac{1}{2}$ - 13	2
	HMB-12-14	Machine Bushing, $\frac{1}{2}$ x 14GA	2
	HWL-12	Lock Washer, $\frac{1}{2}$	1
	HG-14-28-180	Grease Fitting, $\frac{1}{4}$ - 28 x 180°	1

(Continued on next page)

# ENGINE, PUMPS AND EXHAUST DRAWING

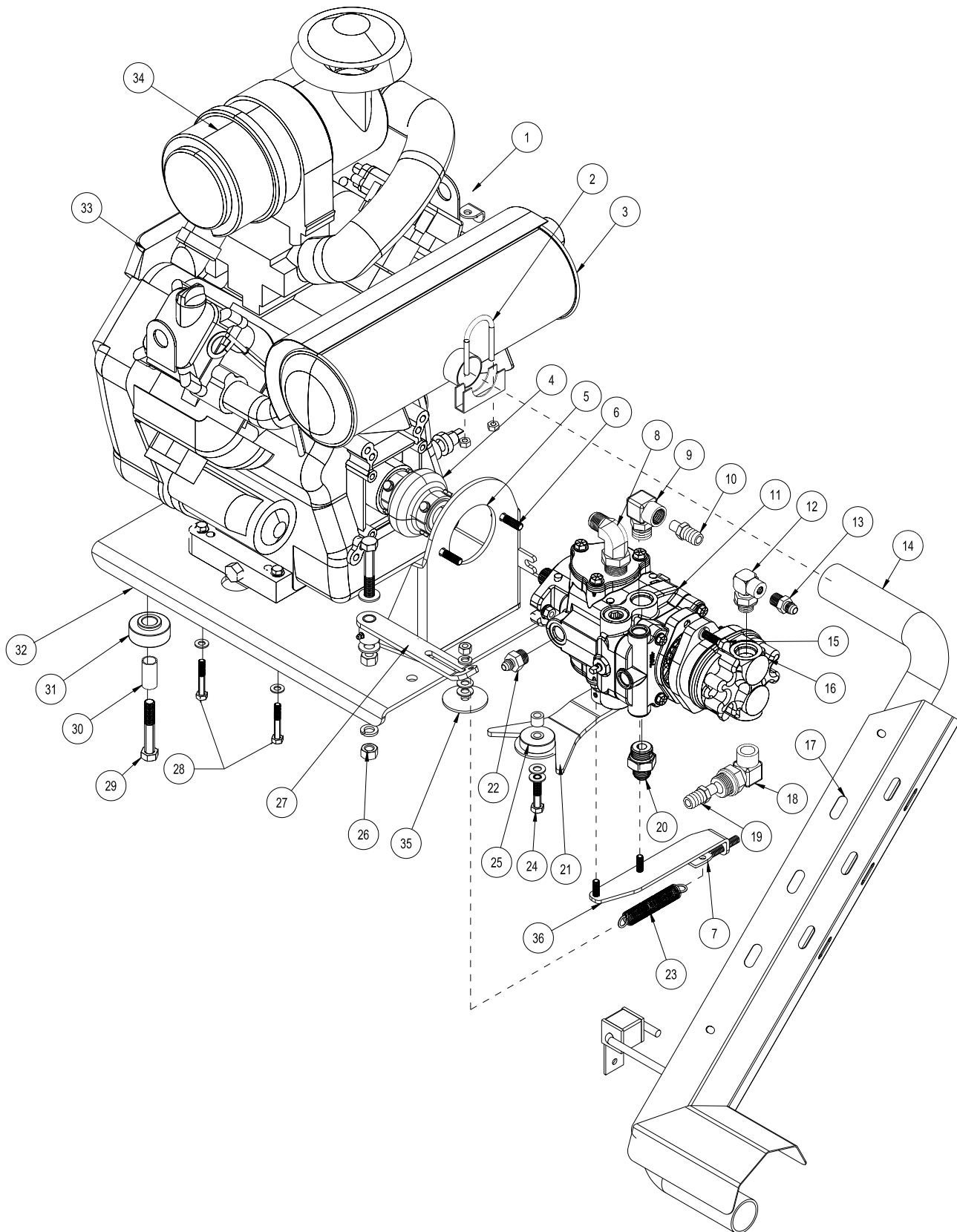

PARTS

## ENGINE, PUMPS AND EXHAUST PARTS LIST

REF#	PART#	DESCRIPTION	QUANTITY
27	15-854	Tensioner Arm	1
28	HB-516-18-200	Hex Bolt, $\frac{5}{16}$ - 18 x 2	4
	HW-516	Flat Washer, $\frac{5}{16}$	4
	HNTL-516-18	Nylon Lock Nut, $\frac{5}{16}$ - 18	4
29	HB-12-13-300	Hex Bolt, $\frac{1}{2}$ - 13 x 3	3
30	60-168	Spacer	3
31	60-107	Rubber Insulator	6
32	15-678	Engine Plate	1
33	76-484	Engine, Briggs & Stratton 31HP	1
	76-487	Engine Oil Filter	1
	21-161	Wire Block	1
34	76-395-04	Cyclonic Air Cleaner	1
	76-395-01	Air Cleaner Cartridge	1
	76-395-02	Safety Filter Cartridge	1
35	20-594	Guide Disc	2
36	15-876	Spring Mount	1

**Cyclonic air cleaner**  
76-395-04

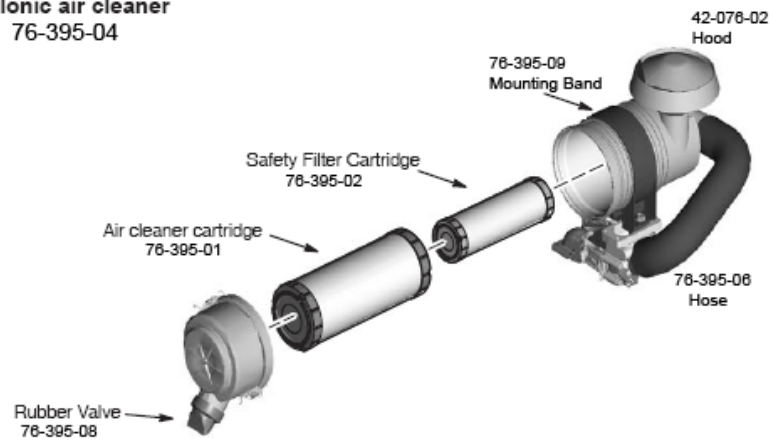

# SPRAY PUMP DRAWING

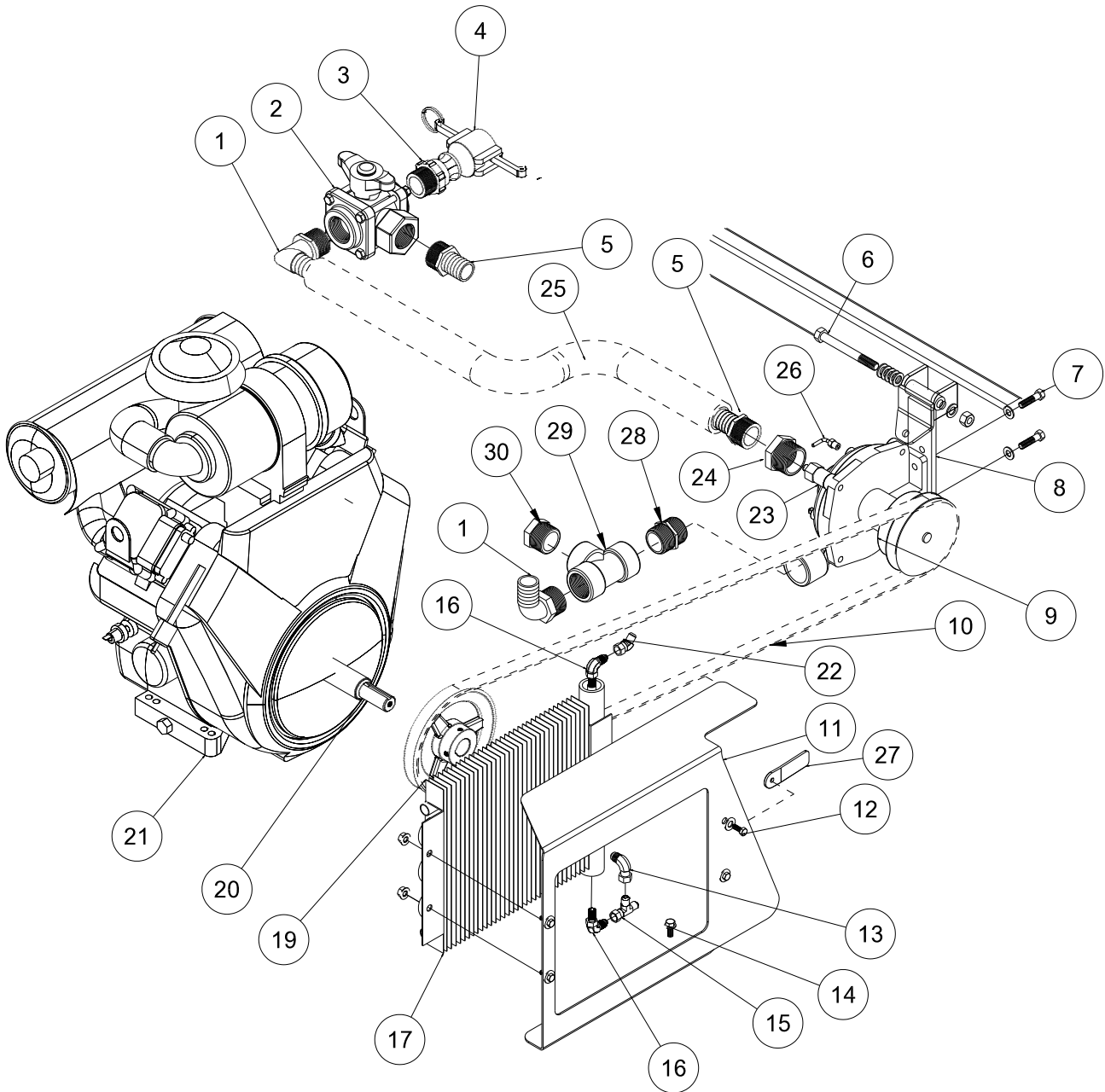

PARTS

# SPRAY PUMP PARTS LIST

REF#	PART#	DESCRIPTION	QUANTITY
1	16-156	Elbow	2
2	18-372	3-Way Valve	1
	18-372-01	T-Handle	1
3	16-180	Quick Coupler Male	1
4	16-935	Quick Coupler Cap	1
5	16-161	Fitting	2
6	HB-12-13-400	Hex Bolt, 1/2 - 13 x 4	1
	HMB-12-14	Machine Bushing, 1/2 x 14GA	2
	HN-12-13	Hex Nut, 1/2 - 13	1
7	HB-38-16-150	Hex Bolt, 3/8 - 16 x 1 1/2	2
	HW-38	Flat Washer, 3/8	2
	HNTL-38-16	Nylon Lock Nut, 3/8 - 16	2
8	15-580	Pump Mount Arm	1
9	16-998	Spray Pump	1
10	15-704	Belt	1
11	15-688	Cooler Panel	1
12	HB-14-20-075	Hex Bolt, 1/4 - 20 x 3/4	4
	HW-14	Flat Washer, 1/4	4
13	18-202	Elbow	1
14	HBFL-516-18-075	Flange Whiz-loc Bolt, 5/16 - 18 x 3/4	2
15	18-190	Tee	1
16	18-168	3/8" Straight Elbow	2
17	15-624	Oil Cooler	1
18	HNFL-14-20	Flange Whiz-loc Nut, 1/4 - 20	4
19	15-703	Pulley	1
20	76-446-01	Stub Shaft (comes with engine)	1
21	76-484	Briggs & Stratton 31 HP Engine	1
	76-487	Engine Oil Filter	1
22	18-214	45° Elbow	1
23	33-480	Pressure Switch	1
24	16-825	Hex Bushing	1
25	8897-19	Discharge Hose, 1 1/4" x 19"	1
	18-222	Hose Clamp	2
26	18-475	Male Elbow	1
27	15-764	Cooler Clamp	1
28	16-880	Nipple	1
29	18-390	Tee	1
30	10-389	Plug	1

# TANK DRAWING

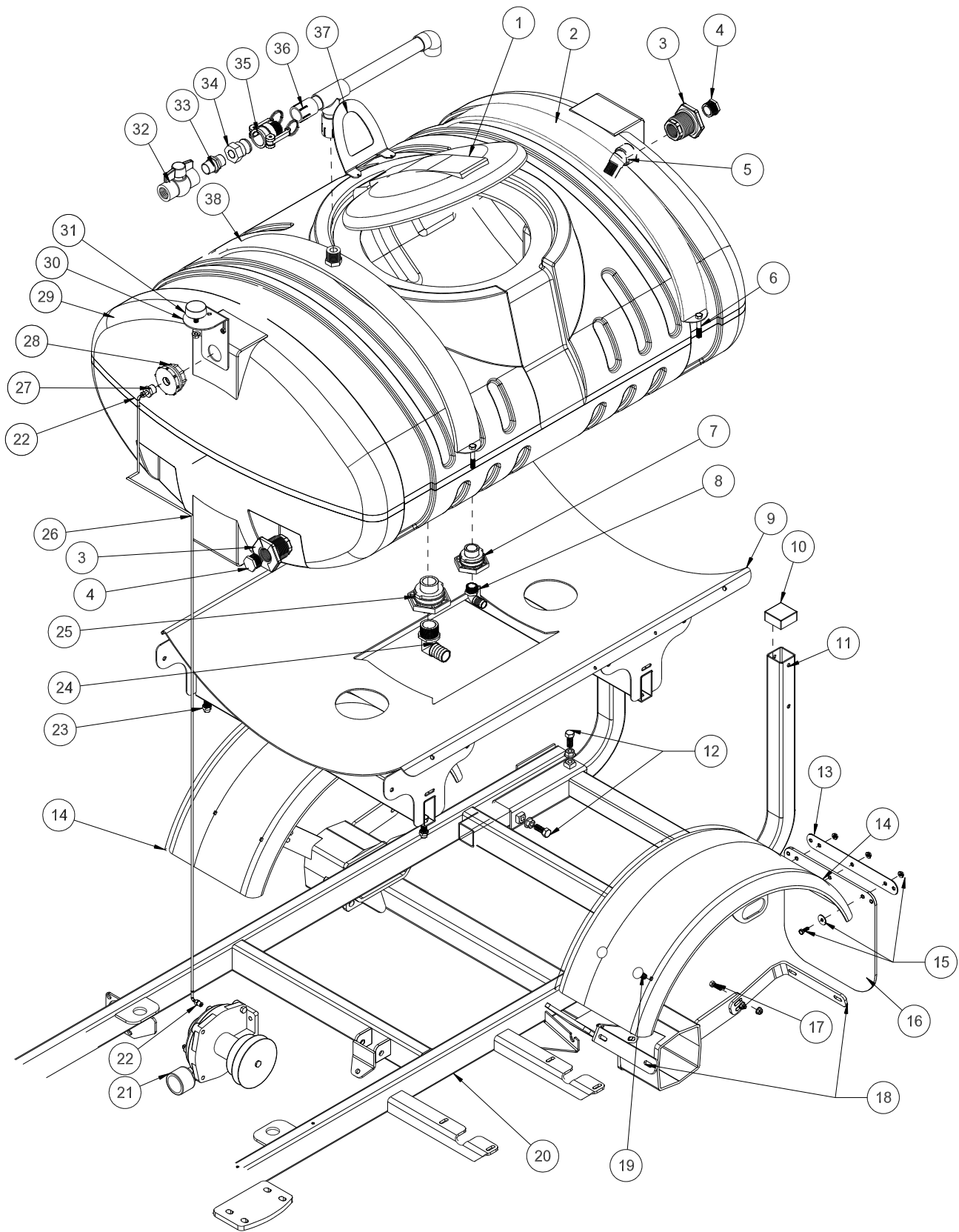

PARTS

# TANK PARTS LIST

REF#	PART#	DESCRIPTION	QUANTITY
1	16-953	16" Hinged Lid Well with Gasket	1
	16-953-01	Gasket (for Lid)	1
	16-169	Strainer Basket	1
2	15-898	Tank Strap	1
3	16-945	1" Double Thread Fitting	2
4	16-162	1" Hex Plug	2
5	16-971	45° Elbow(inside tank)	1
6	HB-38-16-400	Hex Bolt, $\frac{3}{8}$ - 16 x 4	2
	HB-38-16-350	Hex Bolt, $\frac{3}{8}$ - 16 x $3\frac{1}{2}$	2
	HNTL-38-16	Nylon Lock Nut, $\frac{3}{8}$ - 16	4
7		$\frac{1}{2}$ " Double Thread Fitting (part of tank)	1
8	16-155	Elbow	1
9	15-733	Tank Carrier	1
10	16-557	Square Cap	2
11	15-753	Boom Support Tube	2
12	HB-12-13-150	Hex Bolt, $\frac{1}{2}$ - 13 x $1\frac{1}{2}$	4
	HNJ-12-13	Jam Nut, $\frac{1}{2}$ - 13	4
13	20-660	Mud Flap Strap	2
14	10-168	Rear Fender	2
15	HB-14--20-075	Hex Bolt, $\frac{1}{4}$ - 20 x $\frac{3}{4}$	6
	HWF-14	Fender Washer, $\frac{1}{4}$	6
	HNFL-14-20	Flange Whiz-loc Nut, $\frac{1}{4}$ - 20	6
16	20-659	Mud Flap	2
17	HBFL-516-18-075	Flange Whiz-loc Bolt, $\frac{5}{16}$ - 18 x $\frac{3}{4}$	8
	HNFL-516 - 18	Flange Whiz-loc Nut, $\frac{5}{16}$ - 18	8
18	10-466	Rear Fender Brackets	4
19	HBC-516-18-100	Carriage Hex Bolt, $\frac{5}{16}$ - 18 x 1	8
	HNFL-516-18	Flange Whiz-loc Nut, $\frac{5}{16}$ - 18	8
20	15-701	Main Frame	1
21	16-998	Hypro Pump	1
22	18-475	Male Elbow	2
23	HB-12-13-125	Hex Bolt, $\frac{1}{2}$ - 13 x $1\frac{1}{4}$	4
	HNFL-12-13	Flange Whiz-loc Nut, $\frac{1}{2}$ - 13	4
24	16-156	Elbow	1
25	16-194	$1\frac{1}{4}$ Anti Vortex Fitting (part of tank)	1
26	9038-30	Tubing, $\frac{1}{4}$	1
27	33-496	Reducer Bushing, $\frac{1}{2}$ to $\frac{1}{8}$	1
28	33-495	Bulkhead Fitting	1
	16-971	Fitting (inside tank)	1
29	15-897	175 Gallon Spray Tank	1
	16-169	Basket	1
30	15-901	Hood Support	1
31	50-081	Rubber Bumper	1
	HNFL-38-16	Flange Whiz-loc Nut, $\frac{3}{8}$ - 16	1
32	18-448	1" Ball Valve	1
33	16-851	1" Nipple	1
34	16-961	1" Adapter	1
35	16-962	1" Coupler	1
	16-962-01	Buna-N Gasket (for 16-962)	1
36	14-365	Air Gap Filler	1
37	10-639	Lid Stop	1
38	15-899	Front Tank Strap	1

# TURBO-QUAD AGITATOR DRAWING

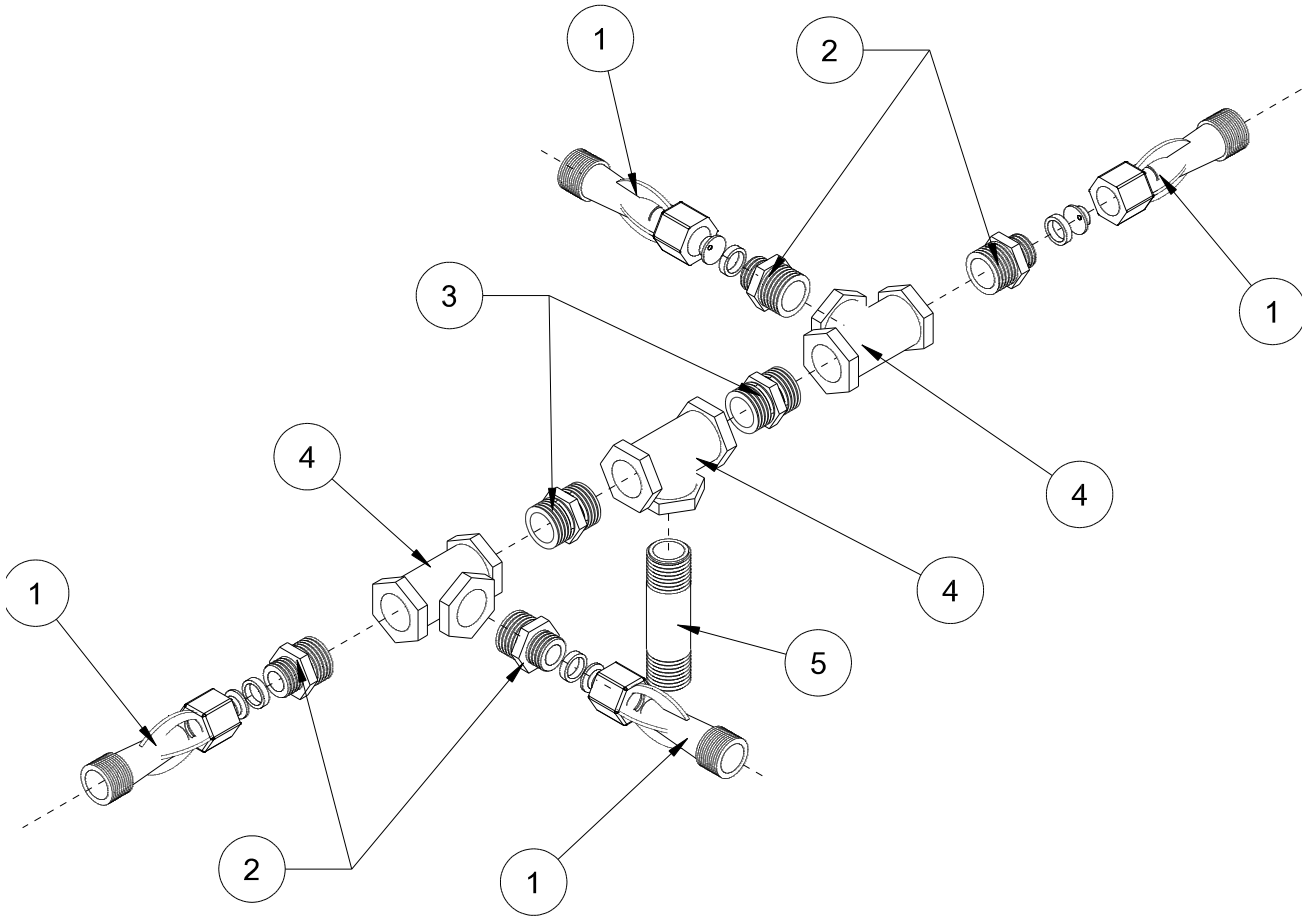

PARTS



## TURBO-QUAD AGITATOR PARTS LIST

REF#	PART#	DESCRIPTION	QUANTITY
1	16-036	Agitator Jet (Includes one each $\frac{1}{8}$ " , $\frac{5}{53}$ " , and $\frac{3}{16}$ " orifices)	4
2	16-173	Reducer, $\frac{3}{4}$ x $\frac{1}{2}$	4
3	16-158	Close Nipple, $\frac{3}{4}$ x $\frac{3}{4}$	2
4	16-157	Female Pipe Thread Tee, $\frac{3}{4}$ x $\frac{3}{4}$ x $\frac{3}{4}$	3
5	16-172	Nylon Nipple, $\frac{3}{4}$ NPT x $3\frac{1}{2}$	1

# PARK BRAKE AND REAR AXLE DRAWING

PARTS

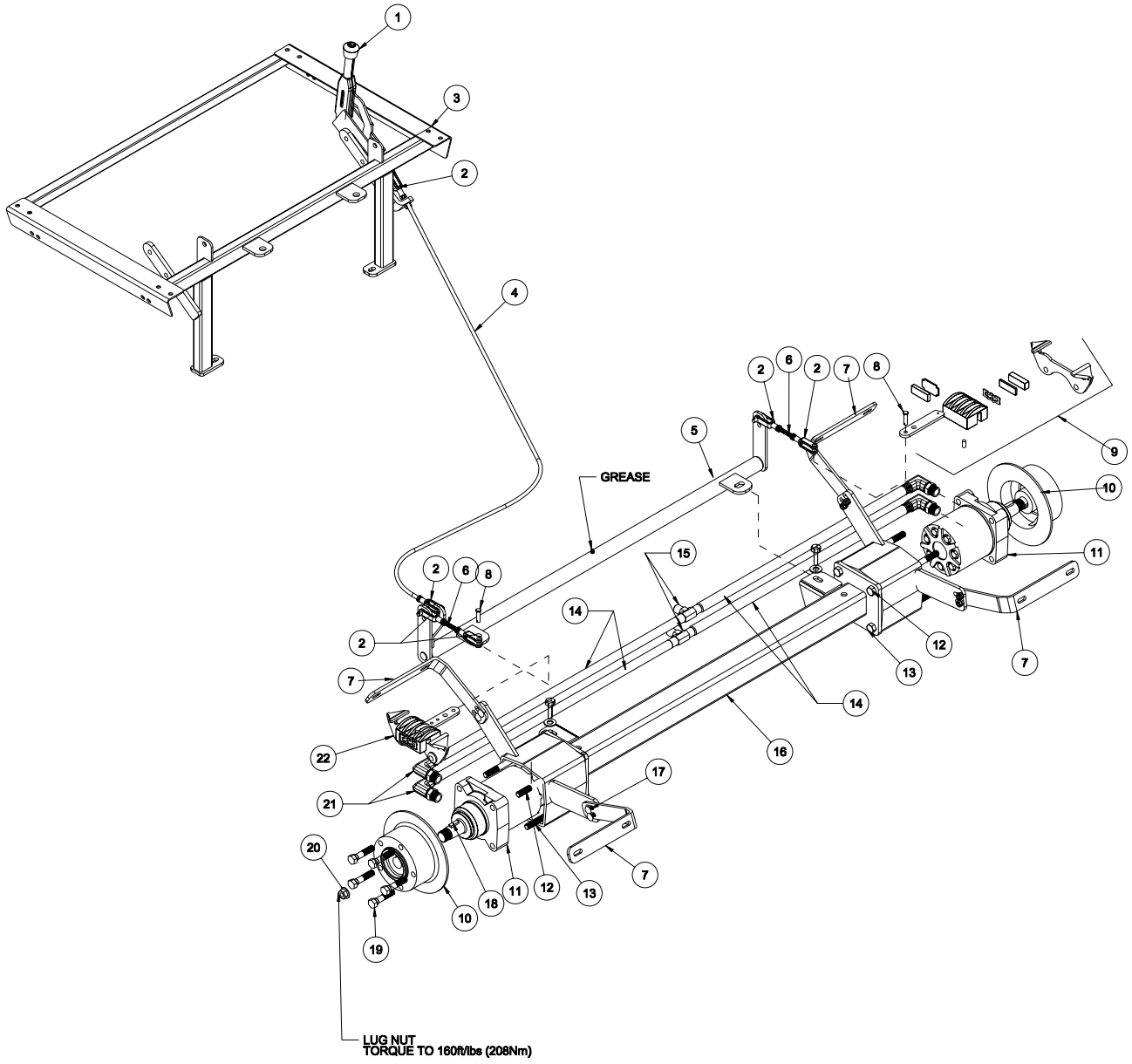

## PARK BRAKE AND REAR AXLE PARTS LIST

REF#	PART#	DESCRIPTION	QUANTITY
1	60-106	Park Brake Lever Kit	1
2	11-100	Linkage Yoke, $\frac{5}{16}$ "	6
	HN-516-24	Hex Nut, $\frac{5}{16}$ - 24	6
3	15-722	Seat Frame	1
4	60-347	Brake Cable	1
5	15-691	Brake Relay	1
6	34-021	Short Rod	2
	HN-516-24	Hex Nut, $\frac{5}{16}$ -24	4
7	10-466	Rear Fender Bracket	4
8	HCP-516-100	Clevis Pin, $\frac{5}{16}$ x 1	5
	HP-18-075	Cotter Pin, $\frac{1}{8}$ x $\frac{3}{4}$	5
9	76-241	Right Caliper CW	1
	34-101-02	Pad Kit	1
10	76-239	Brake Disc, 5-hole	2
11	76-238	Wheel Motor	2
	HMB-12-14	Machine Bushing, $\frac{1}{2}$ x 14GA	4
12	HB-12-13-800	Hex Bolt, $\frac{1}{2}$ - 13 x 8	4
	HNFL-12-13	Flange Whiz-loc Nut, $\frac{1}{2}$ - 13	4
13	HB-12-13-750	Hex Bolt, $\frac{1}{2}$ - 13 x $7\frac{1}{2}$	4
	HNFL-12-13	Flange Whiz-loc Nut, $\frac{1}{2}$ -13	4
14	15-681	Hydraulic Hose	4
15	34-057	Tee	2
16	15-700	Rear Axle	1
17	HBFL-516-18-075	Flange Whiz-loc Bolt, $\frac{5}{16}$ - 18 x $\frac{3}{4}$	8
	HNFL-516 - 18	Flange Whiz-loc Nut, $\frac{5}{16}$ - 18	8
18	HWK-516-100	Woodruff Key, $\frac{5}{16}$ x 1 (comes with wheel motor)	2
19	60-268	Lug Hex Bolt, $\frac{1}{2}$ - 20 x $1\frac{5}{16}$	10
20	14-265	Lug Nut (comes with wheel motor)	2
21	34-122	Short Elbow	4
22	76-240	Left Caliper CCW	1
	34-101-02	Pad Kit	1

# 15-301 ORBITROL DRAWING

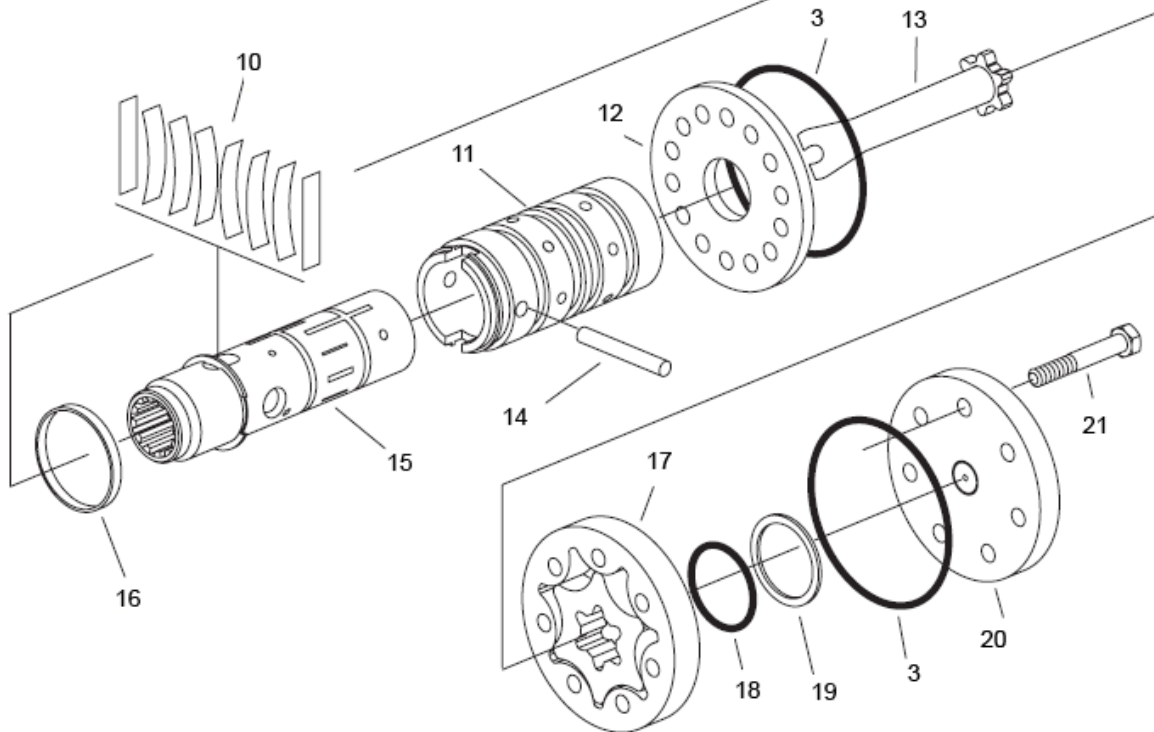
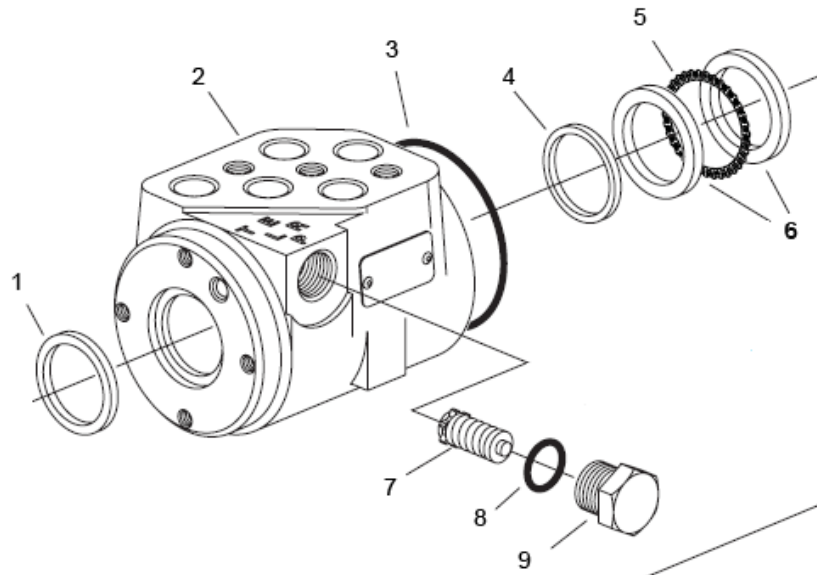

PARTS

# 15-301 ORBITROL PARTS LIST

REF #	PART #	DESCRIPTION	QUANTITY
1	10-576-04	Dust Seal	1
2		Housing	1
3**		O-Ring Seal	3
4**		Quad Seal	1
5	10-576-03	Thrust Bearing	1
6	10-576-02	Bearing Race	2
7		Manual Steering Relief Valve	1
8**		O-ring	1
9		Plug	1
10‡		Standard Torque Centering Springs	1
11		Sleeve	1
12	15-301-06	Wear Plate	1
13	10-576-01	Drive	1
14	15-301-08	Drive Pin	1
15		Spool	1
16‡		Spring Retaining Ring	1
17	10-576-05	Gerotor	1
18**		O-Ring	1
19**		Seal Ring	1
20	15-301-03	End Cap	1
21	10-576-06	Cap Screw	7
**	15-301-01	Seal Kit	1
‡	15-301-15	Centering Spring Kit	1

## 15-301 ORBITROL SPECIFICATIONS

Inlet Relief Valve Setting	1020 psi (70 bar)
Nominal Flow	3 gpm (11 lpm)
Displacement	4.50 cu. in/ R (73.8 cu cm/R)
Check Valve for Manual Steering	Yes
Inlet Pressure Rating	2030 psi (140 bar)
Return Pressure Rating	145 psi (10 bar) Maximum
Fluid	SAE 10W-40 API Service SJ or higher Motor Oil
Ports	9/16 - 18 SAE O-Ring 4 Ports

# 76-482 HYDROSTATIC PUMP DRAWING

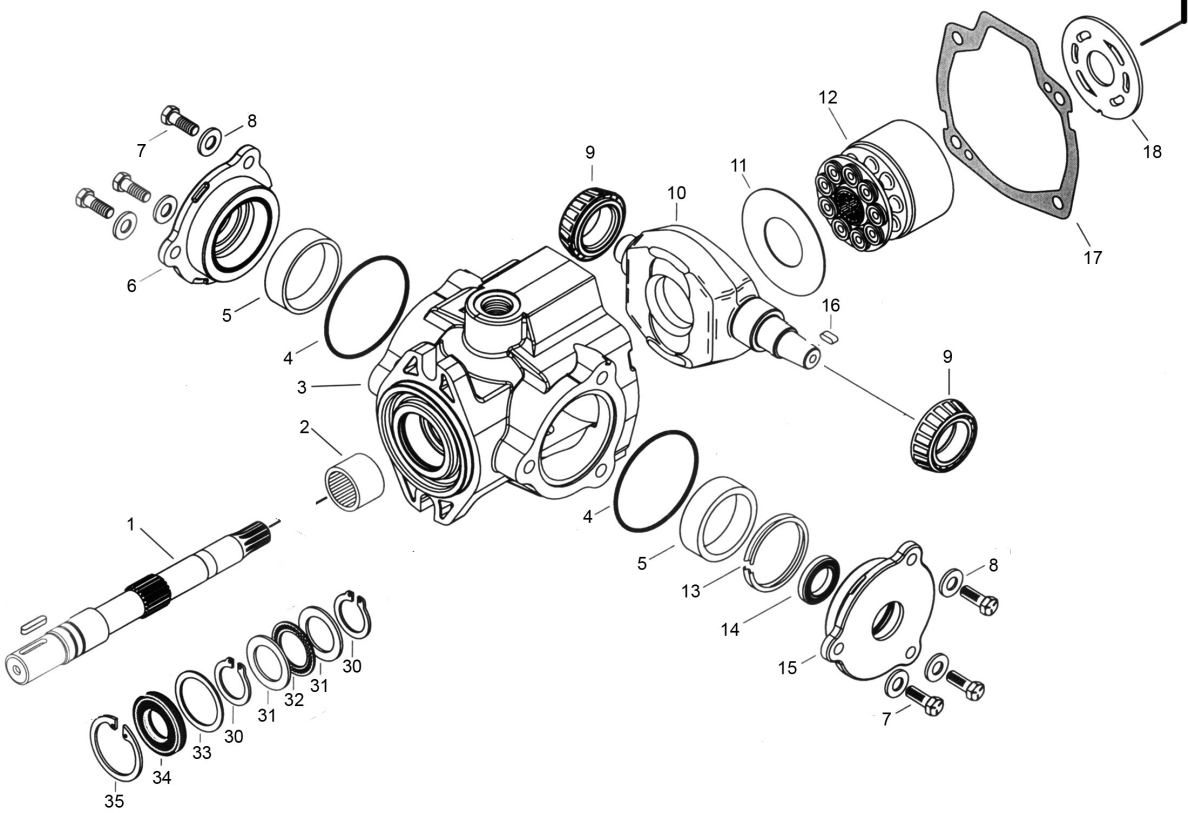
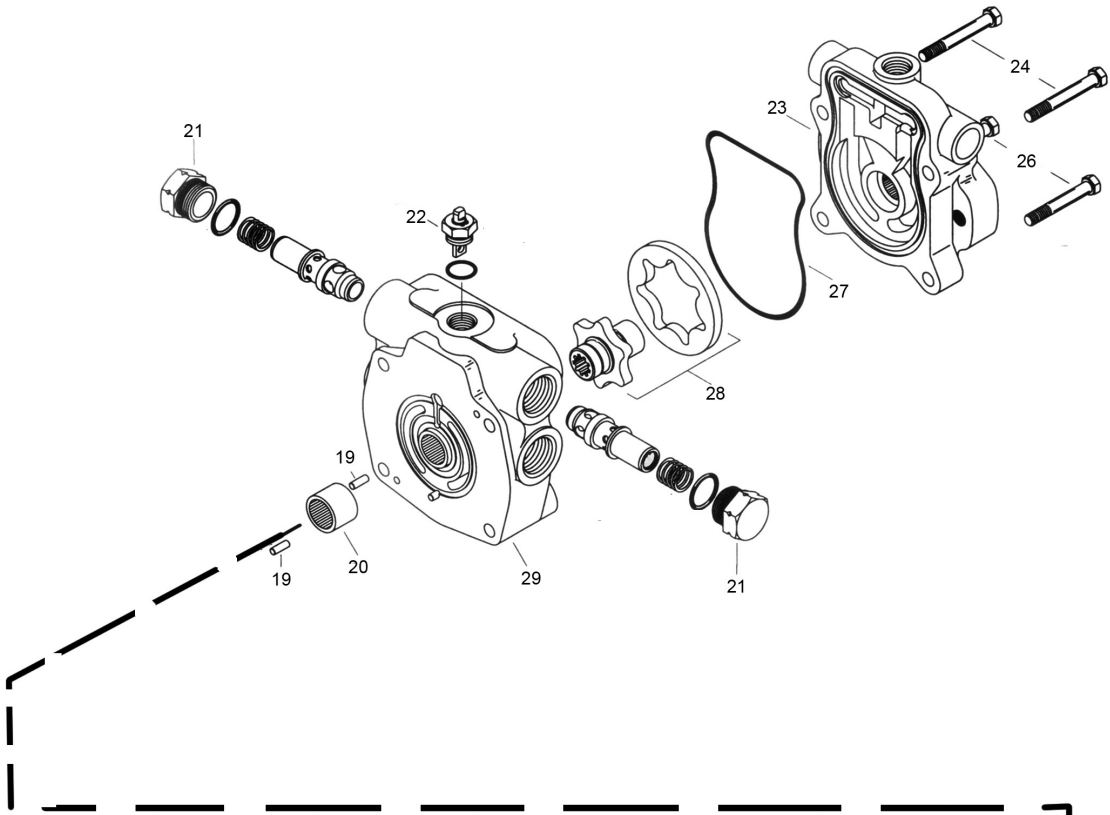

PARTS

## 76-482 HYDROSTATIC PUMP PARTS LIST

REF#	PART#	DESCRIPTION	QUANTITY
1	76-398-01	Drive Shaft (splined)	1
2	60-343-08	Needle Bearing (with housing)	1
3	77-239-01	Housing	1
4	77-239-02	O-Ring	1
5	77-239-03	Thrust Bearing	2
6	77-239-04	Trunnion Cover	1
7	77-239-05	Pan Head Screw	2
8	77-239-06	Washer	6
9	77-239-07	Cone Bearing	2
10	77-239-08	Cam Plate	1
11	77-239-09	Swash Plate Insert	1
12	60-343-21	Rotating Kit	1
13	77-239-10	Crush Ring	1
14*	60-343-12	Shaft Seal	1
15	77-239-11	Seal Cover	1
16	77-239-12	Key	1
17*	77-239-13	Gasket	1
18	76-482-01	Back Plate	1
19	33-058-27	Dowel Pin	2
20	60-343-23	Bearing	1
21	77-239-15	Relief Valve	2
22	77-239-16	Tow Valve Assembly	1
23	76-160	Charge Pump Adaptor	1
24	77-239-17	Cap Screw	2
26	77-239-18	Cap Screw	2
27*	77-239-19	O-Ring	1
28	60-343-43	Gerotor and Coupler	1
29	77-239-20	End Cover Assembly	1
30*	77-239-21	Retaining Ring	2
31	60-343-05	Bearing Race	1
32	60-343-06	Thrust Bearing	1
33	60-343-03	Washer	2
34*	60-343-02	Shaft Seal	1
35*	60-343-01	Retaining Ring	1

\*            77-239-22            Seal Kit

# 76-197 EATON GEAR PUMP DRAWING

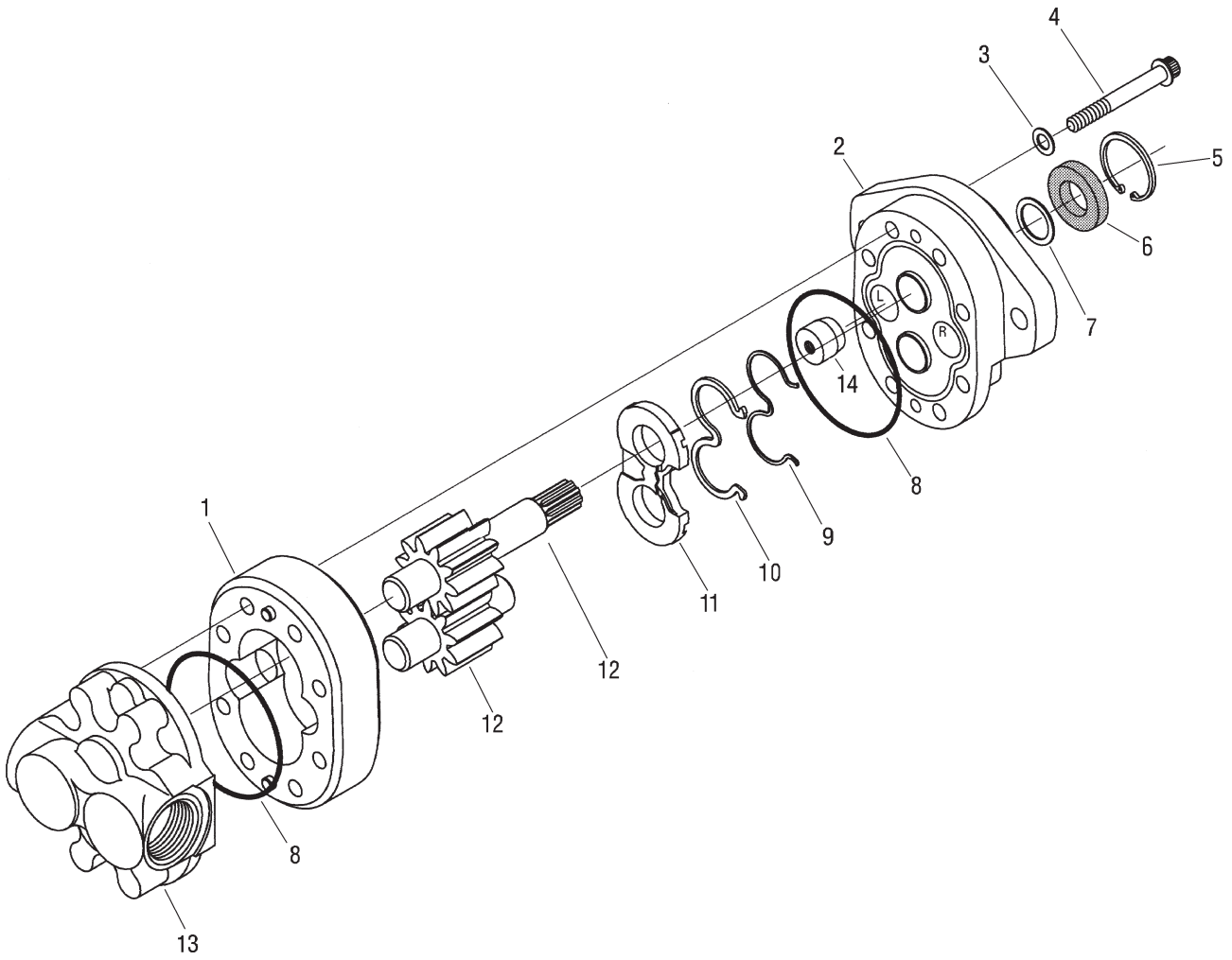

PARTS



## 76-197 EATON GEAR PUMP PARTS LIST

REF#	PART#	DESCRIPTION	QUANTITY
1		Body	1
2	76-197-01	Front Plate	1
3*		Washer	4
4	76-197-06	Cap Screw	8
5	76-197-07	Retaining Ring	1
6*		Shaft Seal	1
7	33-061-15	Washer	1
8*		O-Ring	2
9*		Backup Gasket	1
10*		Seal	1
11*		Wear Plate	1
12	76-197-04	Shaft (comes with Idler Gear)	1
13	76-197-02	Back Plate	1
14*		Plug	1
*	76-197-08	Seal Kit	
	23-145	Oring	

# 16-998 HYPRO PUMP DRAWING

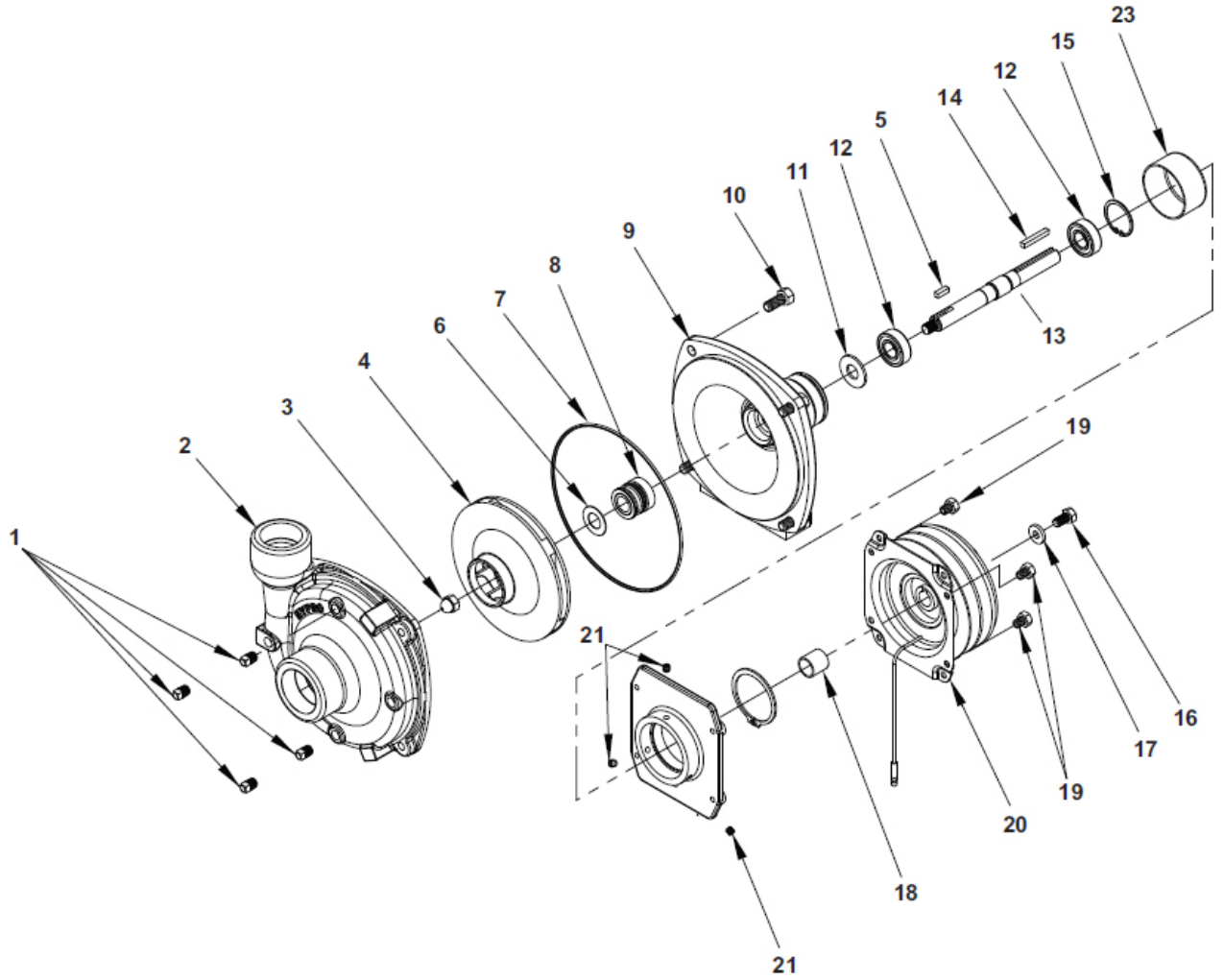

PARTS

## 16-998 HYPRO® PUMP PARTS LIST

REF#	PART#	DESCRIPTION	QUANTITY
1	16-998-01	Drain Plug	4
2	16-998-02	Pump Casing	1
3		Impeller Nut	1
4	16-966-16	Impeller	1
5	16-966-11	Key	1
6	16-998-10	Gasket	1
7*	16-998-04	O-Ring	1
8*	16-967	Mechanical Seal (Silicon Carbide)	1
9	16-998-06	Mounting Flange	1
10	16-998-07	Bolt	
11	16-966-06	Slinger Ring	1
12	16-966-10	Ball Bearing	2
13	16-966-12	Pump Shaft	1
14	16-822-20	Key	1
15	16-966-13	Bearing Retainer	1
16	16-994-05	Bolt	1
17	16-994-06	Retaining Washer	1
18	16-994-03	Spacer	1
19		Bolt	4
20	16-994-01	Clutch	1
21	16-994-04	Set Screw	3
	16-998-12	Pump Only	
*	16-967	Silicone - Carbon Seal Kit	



### IMPORTANT

When servicing the spray pump or filter, all control valves must be shut off if there is liquid in the tank.

# 1752 PLUMBING DRAWING (RADION® 8140)

15-818 #75 Fitting Oring  
 15-817 #50 Fitting Oring

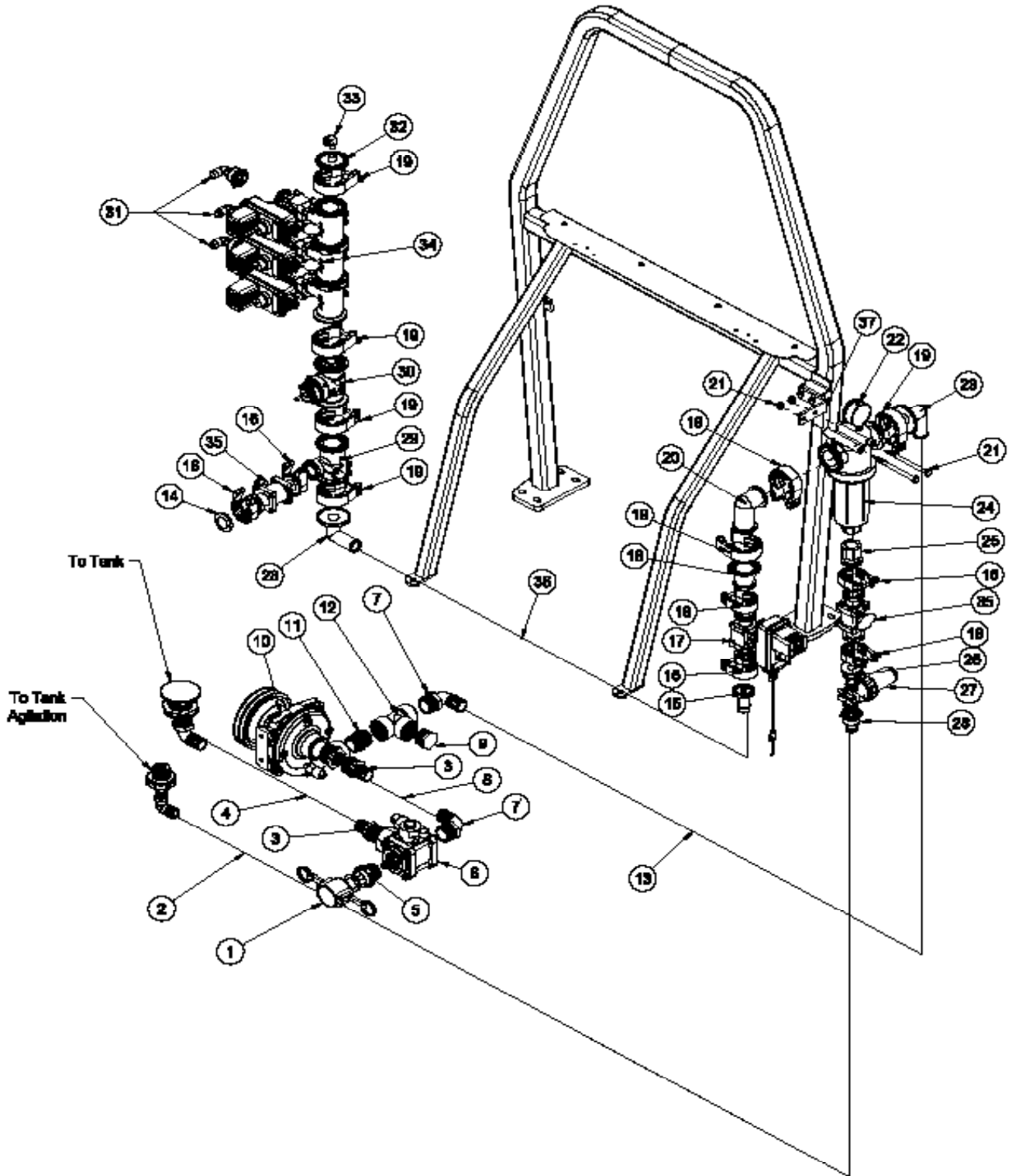

ACCESSORIES

**△ IMPORTANT**

If using Simulated Speed with a Radion 8140, one needs to change back to Ground Speed for proper rate control when spraying.

# 1752 PLUMBING PARTS LIST (RADION® 81401)

REF#	PART#	DESCRIPTION	QUANTITY
1	16-935	Quick Coupler Cap	1
2	8896-68	1" Suction Hose x 68"	1
	18-116	Hose Clamp	2
3	16-161	Fitting	2
4	8897-35	1 <sup>1</sup> / <sub>4</sub> " Discharge Hose x 35"	1
	18-222	Hose Clamp	2
5	16-180	Quick Coupler Male	1
6	18-372	3-Way Valve	1
	18-372-01	T-Handle	1
7	16-156	Elbow	2
8	8897-19	1 <sup>1</sup> / <sub>4</sub> " Discharge Hose x 19"	1
	18-222	Hose Clamp	2
9	10-389	Plug	1
10	16-998	Pump	1
11	16-880	Nipple	1
12	18-390	Tee	1
13	8897-62	1 <sup>1</sup> / <sub>4</sub> " Discharge Hose x 62"	1
	18-116	Hose Clamp	2
14	15-778	Blank Gauge Port Flange	1
15	15-870	#50 1 <sup>1</sup> / <sub>4</sub> " Hose Barb	1
16	15-740	#50 Series Clamp	5
17	20-685	Regulator Valve	1
18	15-748	Reducer Coupling (#75 to #50)	1
19	15-741	#75 Series Clamp	7
20	15-734	#75 Elbow Coupling	1
21	HB-38-16-550	Hex Bolt, <sup>3</sup> / <sub>8</sub> - 16 x 5 <sup>1</sup> / <sub>2</sub>	2
	HNFL-38-16	Flange Whiz-loc Nut, <sup>3</sup> / <sub>8</sub> - 16	2
22	16-281	Liquid Filled Gauge	1
23	15-739	#75 90° Hose Barb	2
24	15-737	Flanged Strainer	1
	16-968-03	Screen (50 mesh)	1
25	15-735	#50 x 1 FTP Fitting	1
26	15-825	#50 Male Quick Coupler	1
27	14-801	Agitator Line Strainer, 50 Mesh	1
	14-802	Replacement 50 Mesh Screen	
28	15-869	1" Hose Barb Outlet	1
	15-553-01	Clip	1
	15-553-02	O-ring	1
29	15-775	Reducer Tee	2
30	20-684	#802 Flow Meter	1
31	15-553	<sup>3</sup> / <sub>4</sub> - 90° Hose Barb	3
32	15-882	#75 Gauge Port	1
33	18-007	Street Elbow	1
34	15-743	Manifold Valve	1
35	15-738	Flanged Ball Valve	2
36	8897-58	1 <sup>1</sup> / <sub>4</sub> " Discharge Hose 58"	1
	18-116	Hose Clamp	2
37	15-904	Filter Bracket	1
	HB-38-16-100	Hex Bolt, <sup>3</sup> / <sub>8</sub> - 16 x 1	2
	HNFL-38-16	Flange Whiz-loc Nut, <sup>3</sup> / <sub>8</sub> - 16	2
<b>FOR 18' BOOM</b>			
	9032-125	<sup>3</sup> / <sub>4</sub> " Black Hose x 125" - Left	1
	9032-90	<sup>3</sup> / <sub>4</sub> " Black Hose x 90" - Center	1
	9032-136	<sup>3</sup> / <sub>4</sub> " Black Hose x 136" - Right	1
	18-040	Hose Clamp	6
<b>FOR 20' BOOM</b>			
	9032-135	<sup>3</sup> / <sub>4</sub> " Black Hose x 135" - Left	1
	9032-90	<sup>3</sup> / <sub>4</sub> " Black Hose x 90" - Center	1
	9032-146	<sup>3</sup> / <sub>4</sub> " Black Hose x 146" - Right	1
	18-040	Hose Clamp	6



# 1754 PLUMBING DRAWING (TEEJET® 744)

15-818  
15-817

#75 Fitting Oring  
#50 Fitting Oring

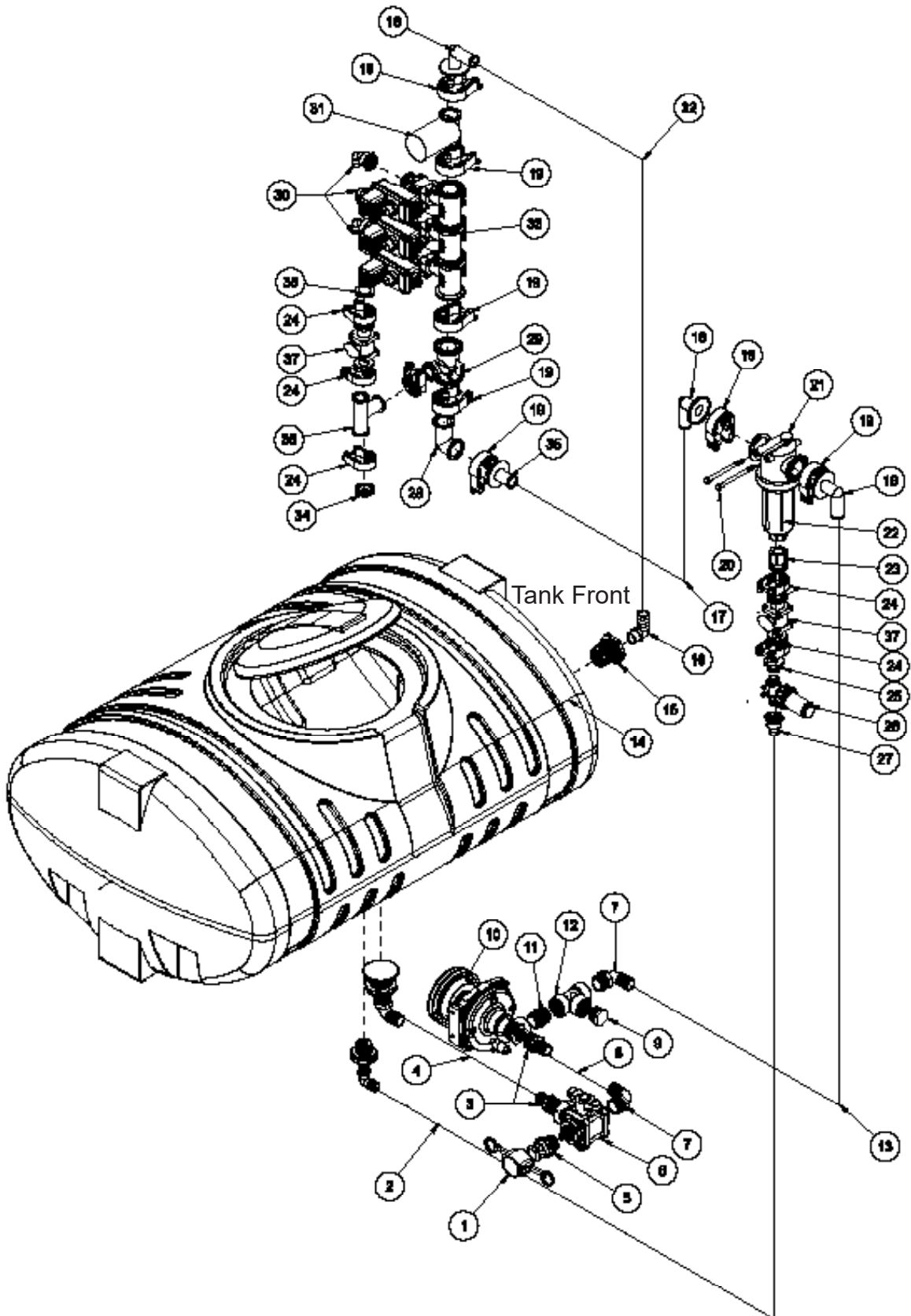

Accessories

# 1754 PLUMBING PARTS LIST (TEEJET® 744)

REF#	PART#	DESCRIPTION	QUANTITY
1	16-935	Quick Coupler Cap	1
2	8896-68	1" Suction Hose x 68"	1
	18-116	Hose Clamp	2
	18-040	Hose Clamp	1
3	16-161	Fitting	2
	16-825	Hex Bushing	1
4	8897-35	1 1/4" Discharge Hose x 35"	1
	18-116	Hose Clamp	2
5	16-180	Quick Coupler Male	1
6	18-372	3-Way Valve	1
	18-372-01	T-Handle	1
7	16-156	Elbow	2
8	8897-19	1 1/4" Discharge Hose x 19"	1
	18-222	Hose Clamp	2
9	10-389	Plug	1
10	16-998	Pump	1
11	16-880	Nipple	1
12	18-390	Tee	1
13	8897-62	1 1/4" Discharge Hose x 62"	1
	18-116	Hose Clamp	2
14	15-879	175 Gallon Spray Tank	1
15	16-945	Double Thread Fitting(part of tank)	1
16	15-779	Hose Barb (remove plug)	1
17	8897-58	1 1/4" Discharge Hose x 58"	1
	18-116	Hose Clamp	2
18	15-739	#75 90° Hose Barb	3
19	15-741	#75 Serise Clamp	7
20	HB-38-16-500	Hex Bolt, 3/8 - 16 x 5	2
	HNFL-38-16	Flange Whiz-loc Nut, 3/8 - 16	2
21	15-780	Poly Hex Plug	1
22	15-737	Flanged Strainer	1
	16-968-03	Screen (50 mesh)	1
23	15-735	#50 1" FTP Fitting	1
24	15-740	#50 Series Clamp	5
25	15-825	QC Flange Adapter	1
26	14-801	Agitator Line Strainer, 50 Mesh	1
	14-802	Replacement 50 Mesh Screen	
27	15-869	1" Hose Barb Outlet	1
	15-553-01	Clip	1
	15-553-02	O-ring	1
28	15-734	#75 Elbow Coupling	1
29	15-775	Reducer Tee	1
30	15-553	3/4- 90° Hose Barb	3
31	16-524	Motorized Control Valve	1
32	8897-26	1 1/4" Discharge Hose x 26"	1
	18-116	Hose Clamp	2
33	15-743	Manifold Ball Valve	1
34	15-777	Gauge Port Flange	1
35	15-744	#75 Hose Barb	1
36	15-776	#50 Tee	1
37	15-738	Flanged Ball Valve	2
38	15-778	Blank Gauge Port Flange	1
<b>FOR 18' BOOM</b>			
	9032-125	3/4" Black Hose x 125" - Left	1
	9032-90	3/4" Black Hose x 90" - Center	1
	9032-136	3/4" Black Hose x 136" - Right	1
	18-040	Hose Clamp	6
<b>FOR 20' BOOM</b>			
	9032-135	3/4" Black Hose x 135" - Left	1
	9032-90	3/4" Black Hose x 90" - Center	1
	9032-146	3/4" Black Hose x 146" - Right	1
	18-040	Hose Clamp	6



# 1755 PLUMBING DRAWING (DYNAJET® + AEROS®)

## FOR 18' BOOM

9032-125	3/4" Black Hose x 125" - Left	1
9032-90	3/4" Black Hose x 90" - Center	1
9032-136	3/4" Black Hose x 136" - Right	1
18-040	Hose Clamp	6

## FOR 20' BOOM

9032-135	3/4" Black Hose x 135" - Left	1
9032-90	3/4" Black Hose x 90" - Center	1
9032-146	3/4" Black Hose x 146" - Right	1
18-040	Hose Clamp	6

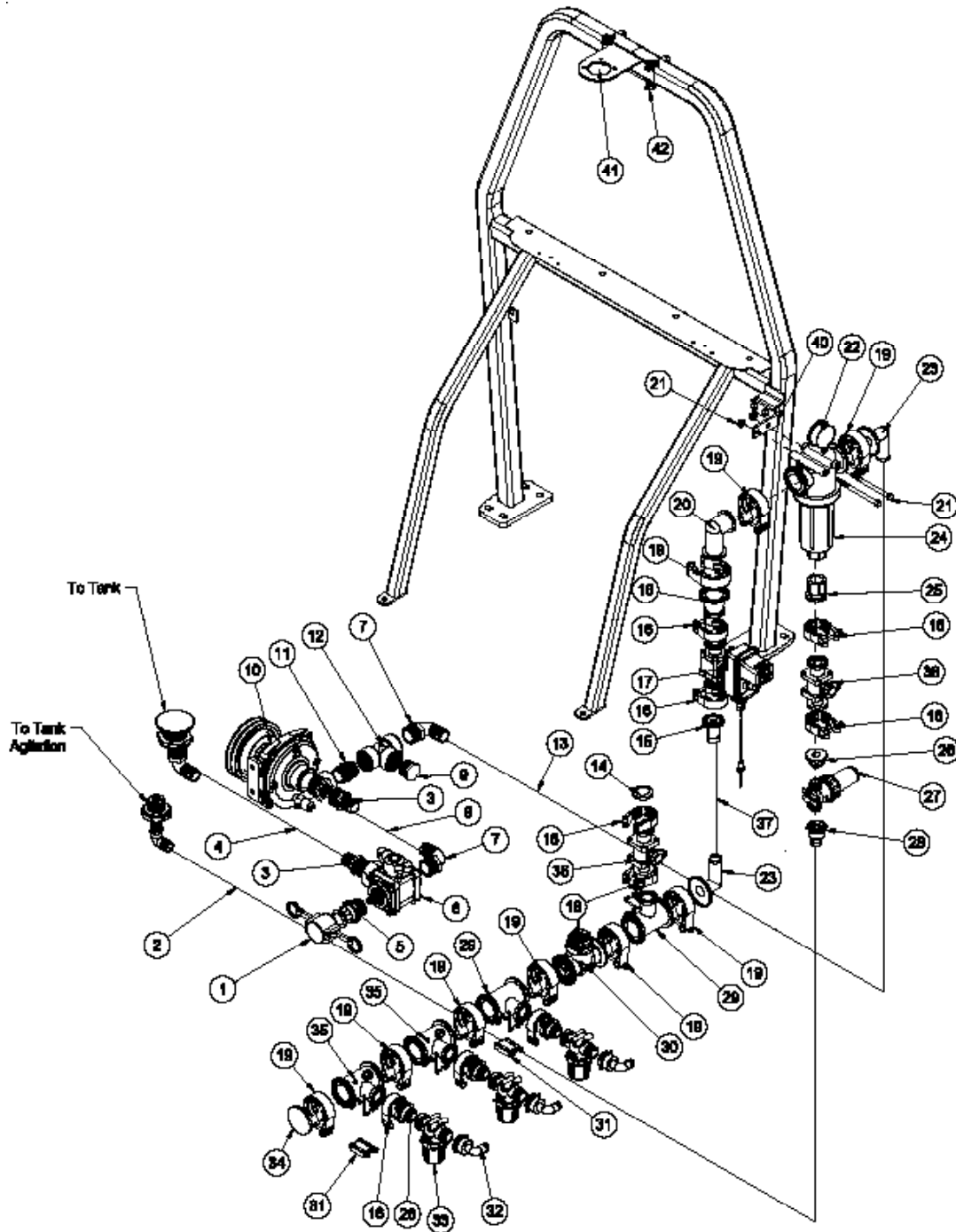

Accessories



# 1755 PLUMBING PARTS LIST (DYNAJET® + AEROS®)

REF#	PART#	DESCRIPTION	QUANTITY
1	16-935	Quick Coupler Cap	1
2	8896-68	1" Suction Hose x 68"	1
	18-116	Hose Clamp	2
3	16-161	Fitting	2
4	8897-35	1 1/4" Discharge Hose x 35"	1
	18-222	Hose Clamp	2
5	16-180	Quick Coupler Male	1
6	18-372	3-Way Valve	1
	18-372-01	T-Handle	1
7	16-156	Elbow	2
8	8897-19	1 1/4" Discharge Hose x 19"	1
	18-222	Hose Clamp	2
9	10-389	Plug	1
10	16-998	Pump	1
11	16-880	Nipple	1
12	18-390	Tee	1
13	8897-62	1 1/4" Discharge Hose x 62"	1
	18-116	Hose Clamp	2
14	15-778	Blank Gauge Port Flange	1
15	15-870	#50 1 1/4" Hose Barb	1
16	15-740	#50 Series Clamp	9
17	20-685	Regulator Valve	1
18	15-748	Reducer Coupling (#75 to #50)	1
19	15-741	#75 Series Clamp	9
20	15-734	#75 Elbow Coupling	1
21	HB-38-16-550	Hex Bolt, 3/8 - 16 x 5 1/2	2
	HNFL-38-16	Flange Whiz-loc Nut, 3/8 - 16	2
22	16-281	Liquid Filled Gauge	1
23	15-739	#75 90° Hose Barb	2
24	14-628	Flanged Strainer with 80 Mesh screen	1
25	15-735	#50 x 1 FTP Fitting	1
26	15-825	#50 Male Quick Coupler	4
27	14-801	Agitator Line Strainer, 50 Mesh	1
	14-802	Replacement 50 Mesh Screen	
28	15-869	1" Hose Barb Outlet	1
	15-553-01	Clip	1
	15-553-02	O-ring	1
29	15-775	Reducer Tee	2
30	20-684	#802 Flow Meter	1
31	15-743-03	Mounting Rail	2
	15-743-06	SS Screw	8
32	15-553	3/4 - 90° Hose Barb	3
33	14-607	QC Strainer 100 Mesh	3
34	15-742	#75 Inlet Cover	1
35	30-164	Tapped Reducer Tee	2
36	15-738	Flanged Ball Valve	2
37	8897-58	1 1/4" Discharge Hose x 58"	1
	18-116	Hose Clamp	2
38	17-537	Square U-Bolt	2
39	20-668	GNS Antenna Mount (Aeros Only)	1
40	15-904	Filter Bracket	1
	HB-38-16-100	Hex Bolt, 3/8 - 16 x 1	2
	HNFL-38-16	Flange Whiz-loc Nut, 3/8 - 16	2

# DYNAJET® MODULE MOUNTS

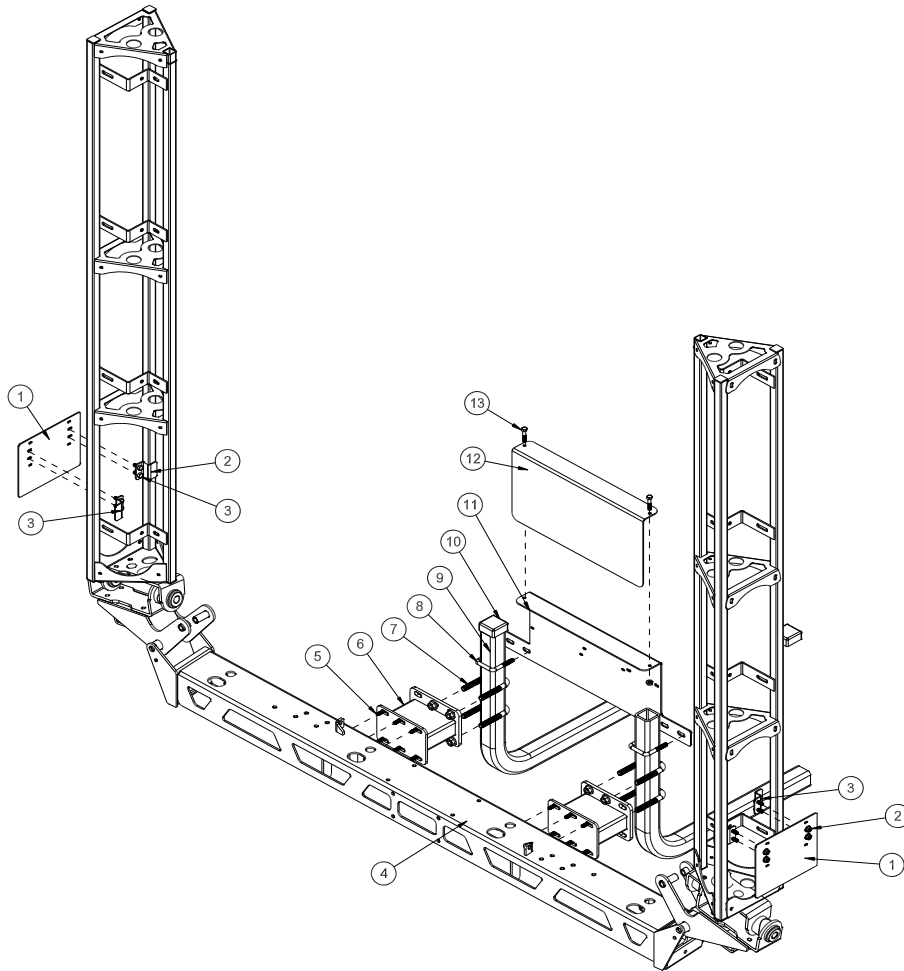

REF#	PART#	DESCRIPTION	QUANTITY
1	20-665	Drive Module Bracket	2
2	20-664	Z Bracket	4
3	HSTP-14-20-075	Machine Screw, $\frac{1}{4}$ - 20 x $\frac{3}{4}$	10
	HNFL-14-20	Flange Whiz Lock Nut, $\frac{1}{4}$ - 2	10
4		Center Boom Mount	1
5	HB-516-18-100	Bolt, $\frac{5}{16}$ - 18 x 1	12
	HNTL-516-18	Lock Nut, $\frac{5}{16}$ - 18	12
6	17-614	Boom Spacer	2
7	20-555	U-Bolt	4
	HNFL-12-13	Flange Whiz-loc Nut, $\frac{1}{2}$ - 13	8
8	17-537	Square U-bolt	2
9	17-615	Boom Carrier	2
10	16-557	Square Cap	2
11	20-667	Module Mount Bracket	1
12	20-666	Module Cover Bracket	1
13	HB-516-18-150	Hex Bolt, $\frac{5}{16}$ - 18 x $1\frac{1}{2}$	2
	HNFL-516-18	Flange Whiz-loc Nut, $\frac{5}{16}$ - 18	2

# 1752 SYSTEM WIRING IRADION® 8140I

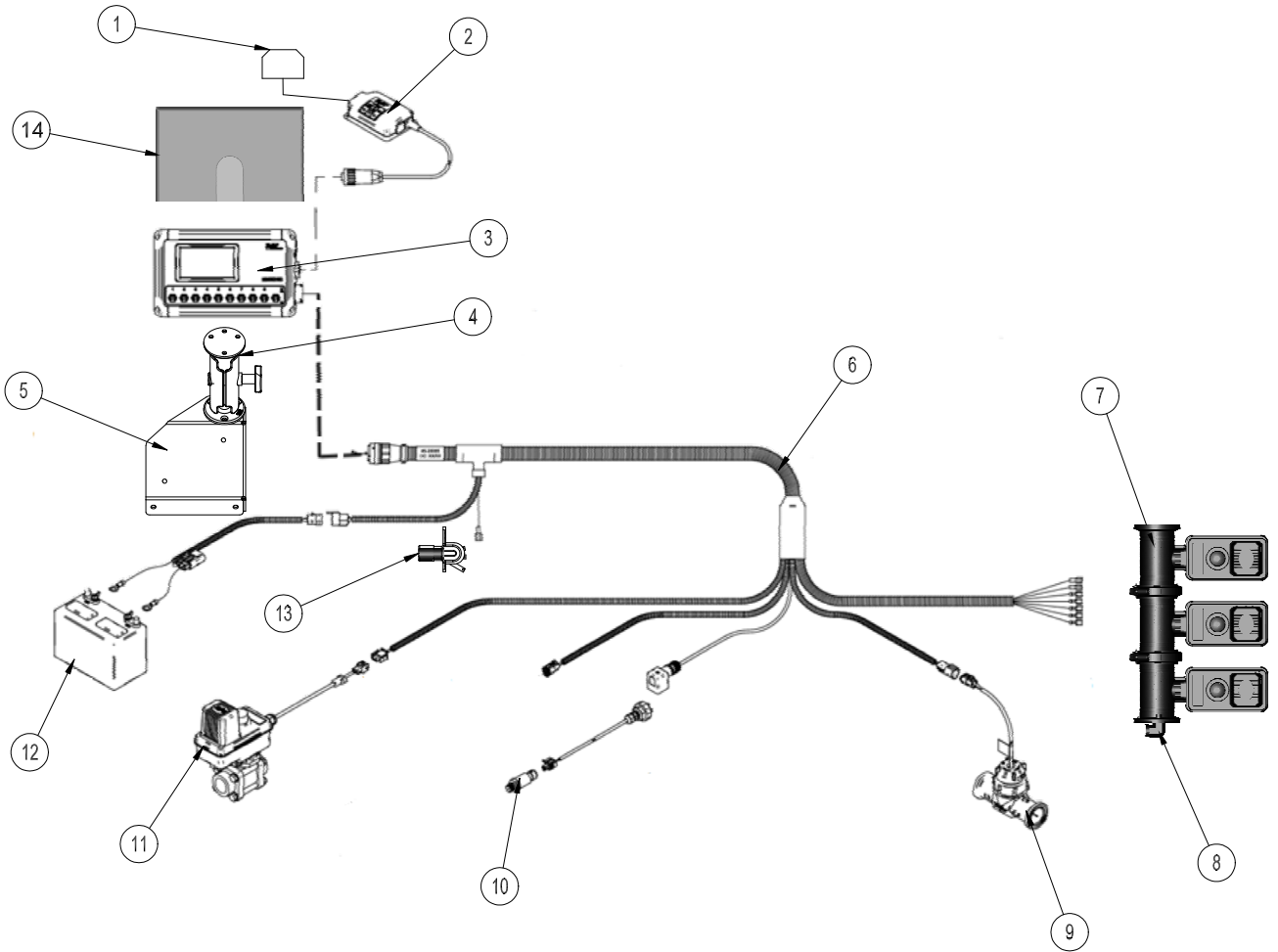

**▲ IMPORTANT**

If using Simulated Speed with a Radion 8140, one needs to change back to Ground Speed for proper rate control when spraying.

REF#	PART#	DESCRIPTION	QUANTITY
1*		Antenna	1
2*	20-687-02	GPS Speed Sensor	1
3*	20-697-01	Radion 8140 Console	1
4	20-540	Ram Mount	1
5	10-643	Mount Bracket	1
6*		Wire Harness	1
7	15-743	Manifold Valve	1
8	18-007	Elbow	1
9	20-684	Flow Meter	1
10*	20-670-04	Pressure Sensor	1
11	20-685	Regulator Valve	1
12	33-509	Master Boom Control	1
13	33-216	Battery	1
14	20-781	Radion Console Cover	1
*	20-697	TeeJet® Radion Kit (includes * items)	1

Accessories

Use Dielectric Grease On All Electrical Connections

# 1754 SYSTEM WIRING [TEEJET 744®]

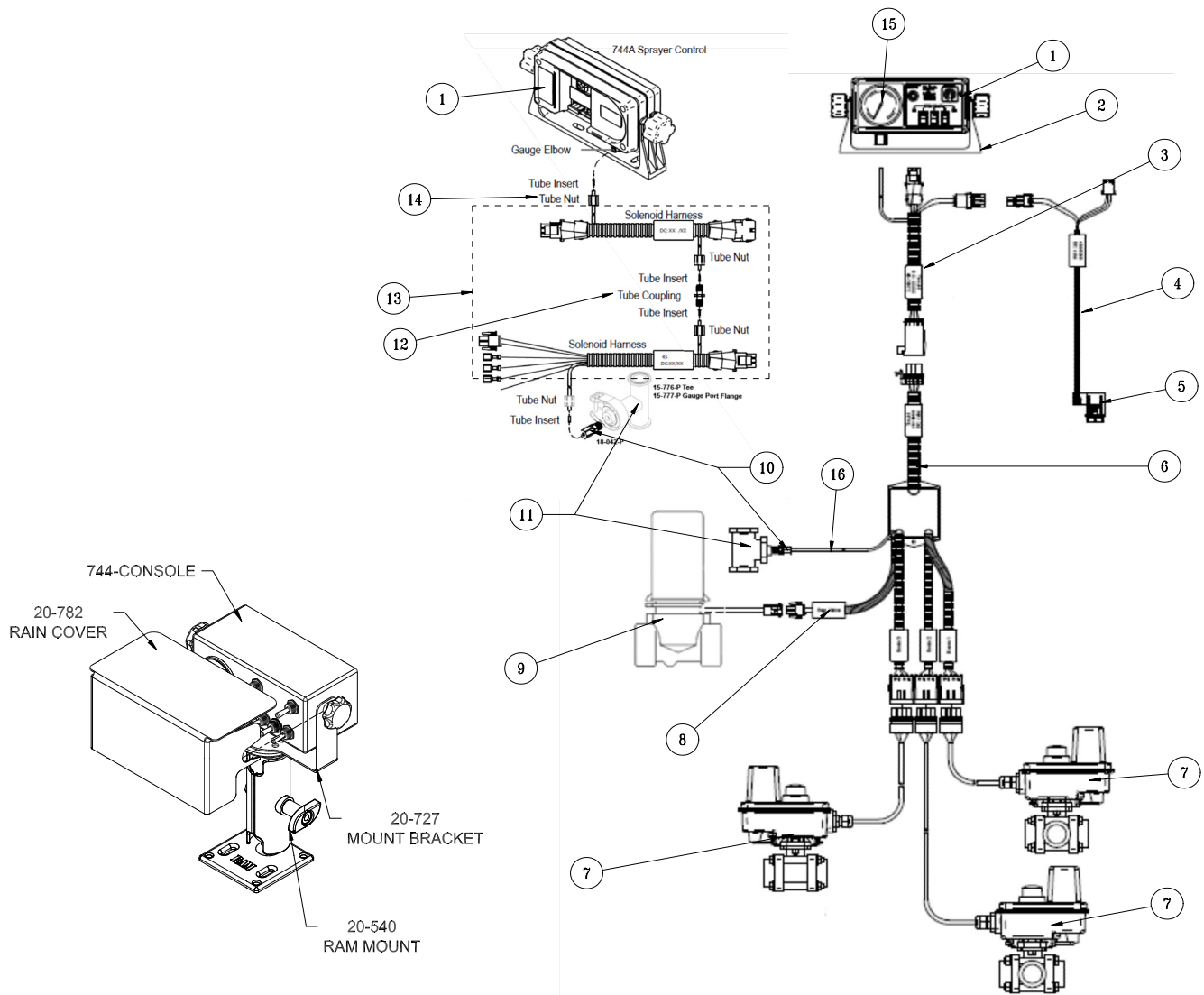

REF#	PART#	DESCRIPTION	QUANTITY
1*	20-688-02	744A Console	1
	20-688-01	200PSI Gauge	1
2	20-727	Mount Bracket	1
	20-540	Ram Mount	1
3*		Console harness	1
4*		Fused Power Cable	1
5	33-271	Fuse Block	1
6*		Ball Valve Wire Harness	1
7	15-743	Manifold Ball Valve	1
8*		Regulator Valve Adapter	1
9	16-524	Regulating Valve	1
10	18-042	Reducer Bushing	1
11	15-776	Tee, 50 Series	1
	15-777	Gauge Port Flange	1
12*	20-688-05	Tube Coupling	1
13*		Tube Nut Kit	1
14*	20-688-06	Tube Nut	1
15*	20-688-01	PSI Liquid Gauge	1
*	20-688	744A Kit Complete (includes * items)	

# 1755 WIRING TEEJET® AEROS SYSTEM

20-767 RX720 RECEIVER  
20-736-01 COM 1 CABLE

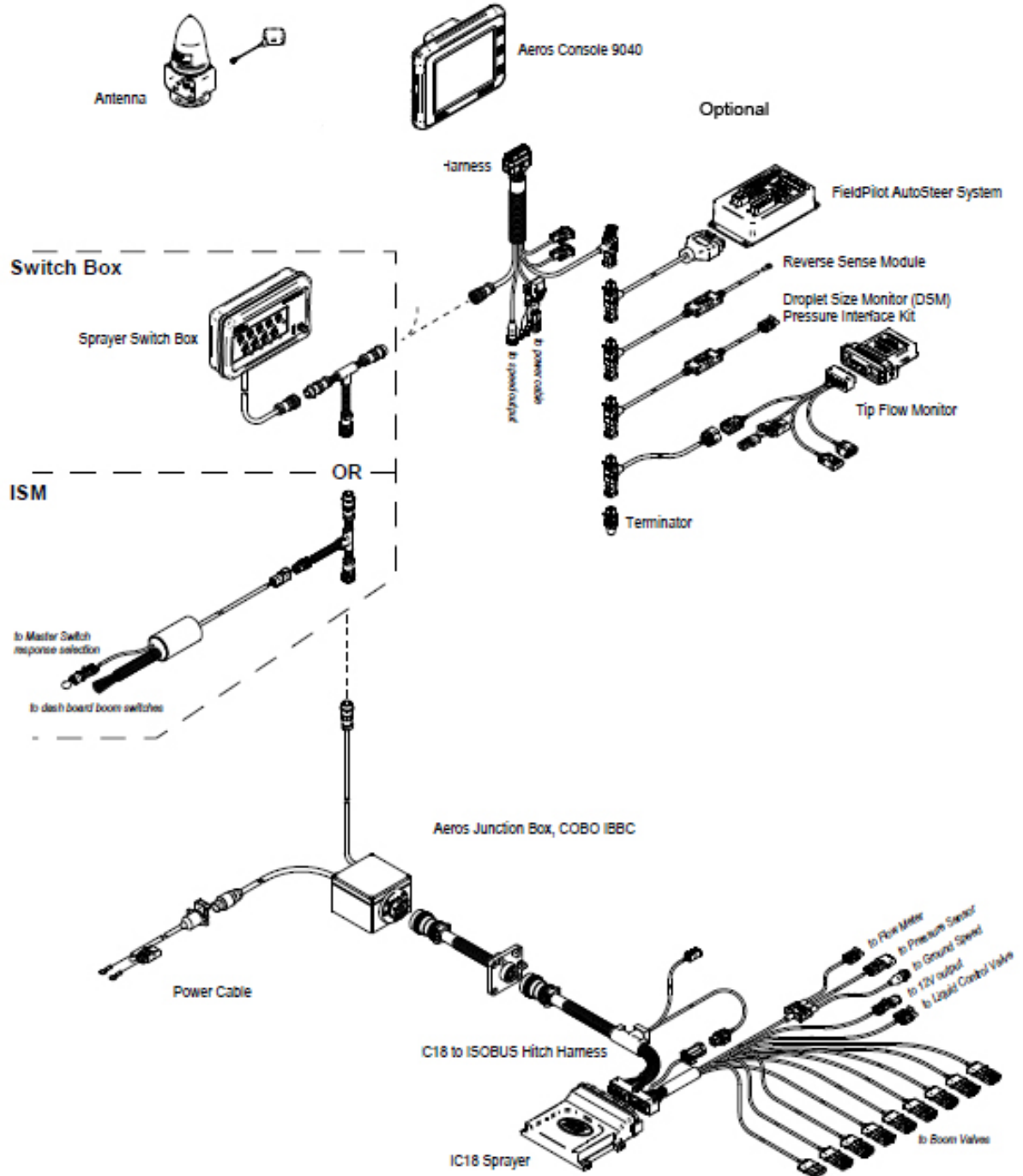

# WIRING TEEJET® DYNA JET SYSTEM

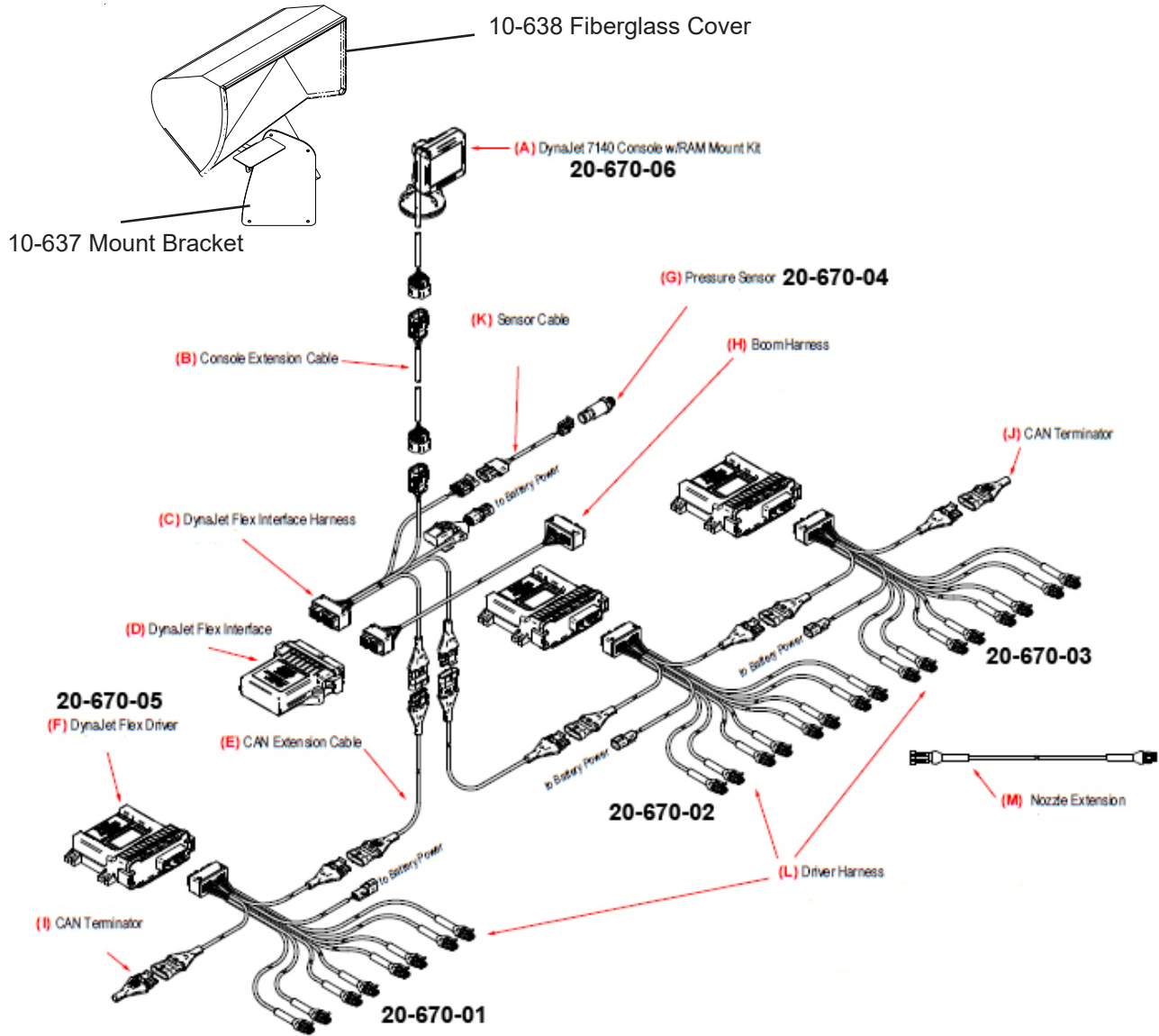

ACCESSORIES

# 14-801 AGITATION STRAINER

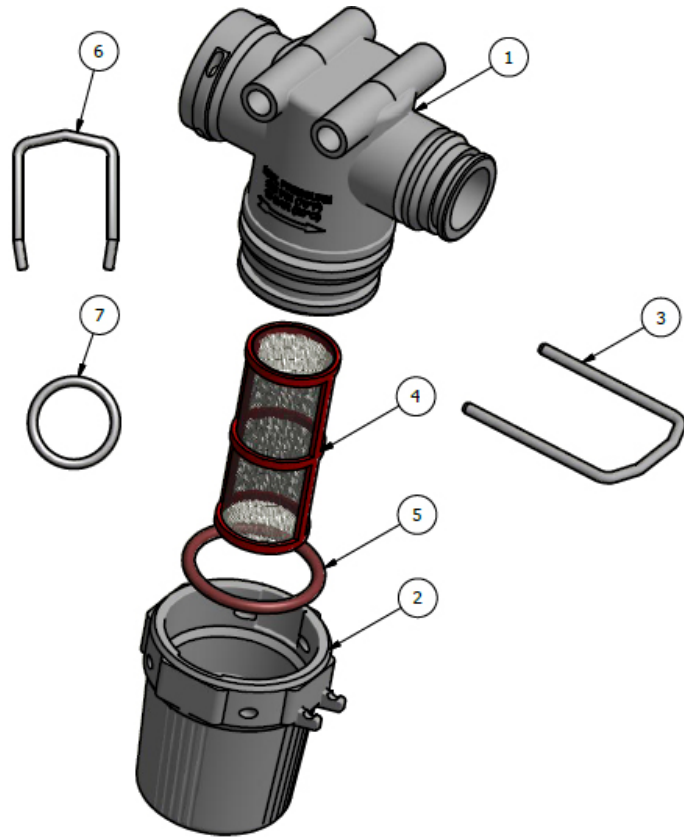

REF#	PART#	DESCRIPTION	QUANTITY
1		QC Strainer Head	1
2		Bowl	1
3		Strainer QC Retaining Clip	1
4	14-802	50 Mesh Strainer	1
5		Viton Oring	1
6	15-553-01	Retaining Clip	1
7	15-553-02	Viton Oring	1

# 16-524 MOTORIZED CONTROL VALVE DRAWING

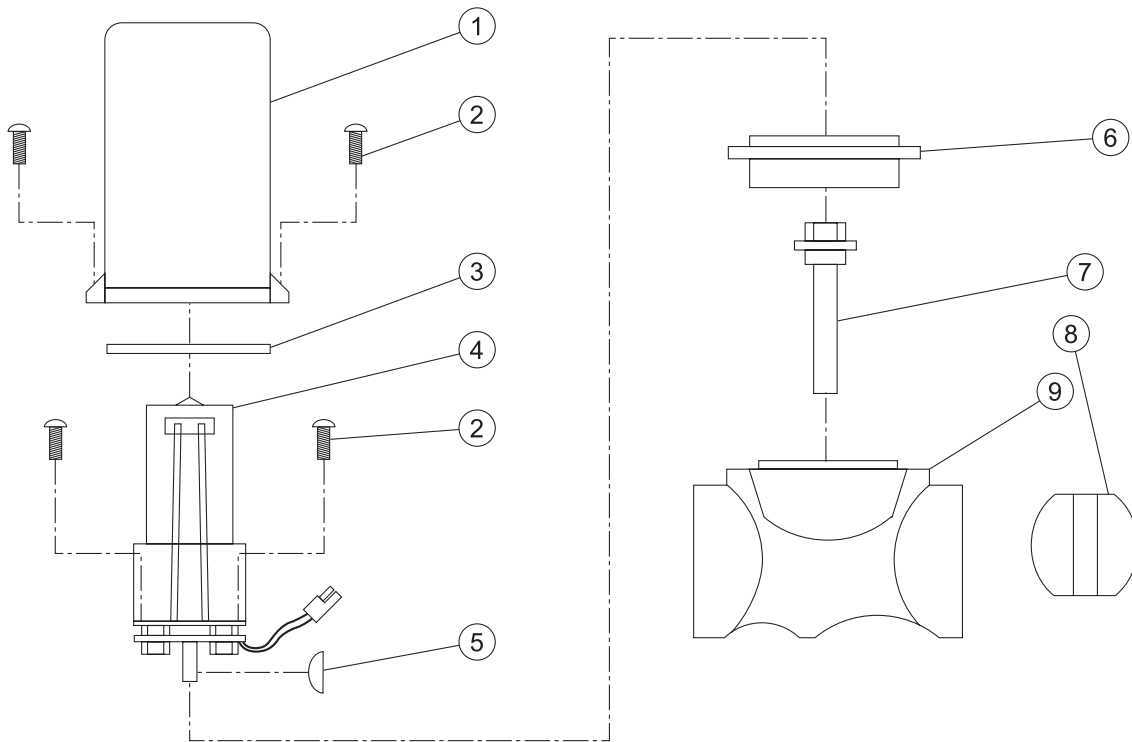

REF#	PART#	DESCRIPTION	QUANTITY
1	16-870	Valve Cover	1
2*	16-524-01	#6 Self Tapping Screw $\frac{3}{4}$ " Long	6
3	16-897	Seal Tetraseal	1
4	16-875	Motor Assembly	1
5*	16-957	Woodruff Key	1
6*	16-524-04	Isolation Flange Assembly	1
7*	16-524-02	Coupler Shaft	1
8*	16-956	Butterfly	1
9*	16-524-03	Valve Body Assembly	1
*	16-524-05	1" Valve ISO-Body Kit	

## WHEN SERVICING VALVE:

Replace valve body with ISO-Body Kit if valve has been leaking internally.

Replace motor assembly if the motor will not run or if the printed circuit board is corroded.

Before reassembling valve, remove the coupler shaft from the valve body. Apply Loctite to coupler shaft and woodruff key. Place the coupler shaft (Ref 7) and the woodruff key (Ref 5) onto the motor shaft. Plug motor into the valve connector coming from Sprayer Control Console. Check that the motor rotates in both directions. Motor must stop when coupler CAM releases printed circuit board switch button. When reassembling valve, grease both sealing surfaces of coupler shaft. Insert coupler shaft into Iso-flange and be sure seal properly seats on shaft. Install on valve body and apply RTV 738 to mounting holes. Reassemble remaining items as shown in parts diagram on opposite side.



# 15-737/ 14-628 FLANGED STRAINER DRAWING

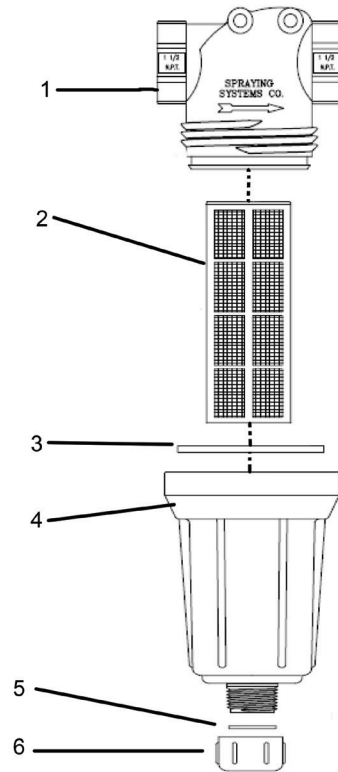

REF#	PART#	DESCRIPTION	QUANTITY
1	15-737-01	Strainer Head 75 Series	1
2*	16-968-03	50 Mesh Screen	1
**	16-968-05	80 Mesh Screen	1
3	14-521-02	EPDM Gasket	1
4	14-521-03	Bowl 1" NPT	1
5	14-521-04	EPDM Rubber gasket	1
6	14-521-05	Cap	1

\* 15-737 Flanged Strainer Assembly with 50 Mesh Screen  
 \*\* 14-628 Flanged Strainer Assembly with 80 Mesh Screen

Accessories

# 15-743 MANIFOLD VALVE DRAWING

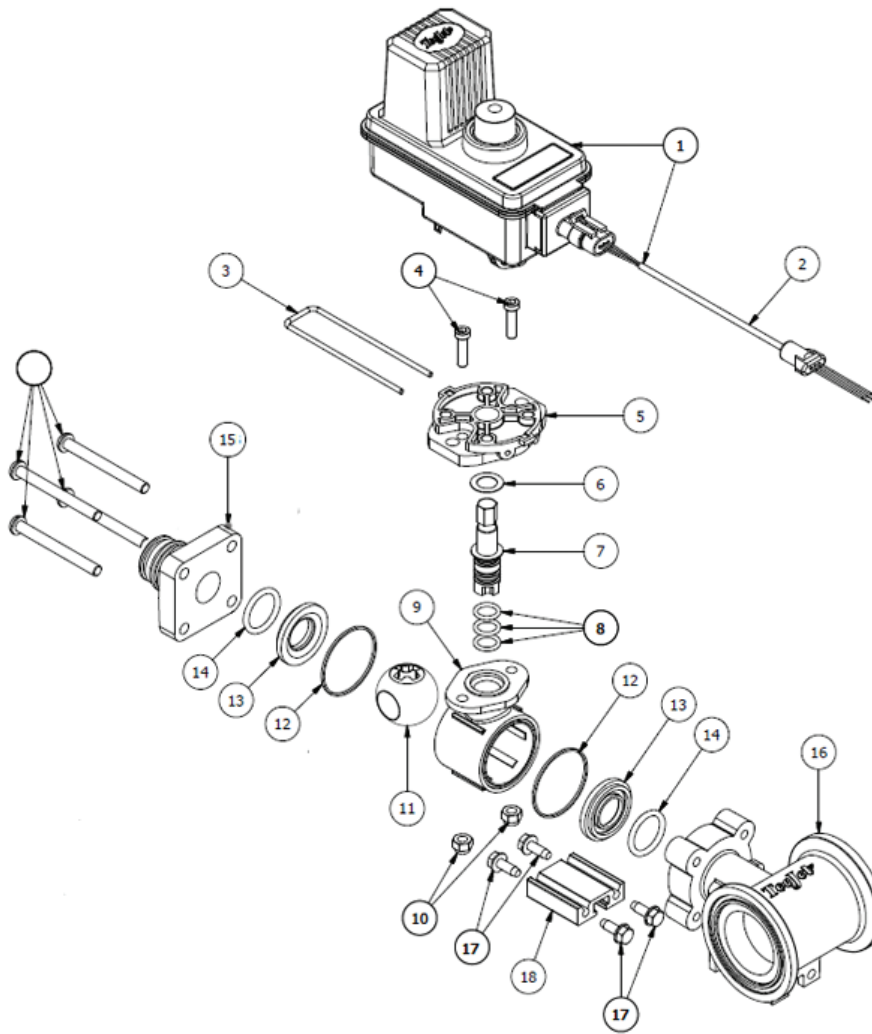

REF#	PART#	DESCRIPTION	QUANTITY
1	15-552-23	Motor	
2	15-878	Metri-Pack Cable (comes with motor)	1
3	15-552-24	Retaining Clip	1
4	15-552-25	Socket Head Cap Screw, Stainless Steel	2
5	15-552-26	Motor Adapter, Polypropylene	1
6*	15-517-11	Thrust Washer, Teflon	1
7	15-552-27	Stem, Stainless Steel	1
8*	15-552-05	O-ring, Viton	3
9	15-517-16	Body, Nylon	1
10		Lock Nut, Stainless Steel	2
11	15-743-04	Ball, Polypropylene	1
12*	15-552-13	Gasket, Viton	2
13*	15-517-19	Seal, Teflon	2
14*	15-517-20	O-ring, Viton	2
15	15-743-01	End Cap	1
16	15-743-02	#75 Tee Body	1
17	15-743-06	Screw, SS	4
18	15-743-03	Mounting Rail Aluminum	1

\* 15-552-10 Spare Parts Kit (includes all \* items)  
 15-743-05 Single Valve (shown)

# 20-685 REGULATOR VALVE

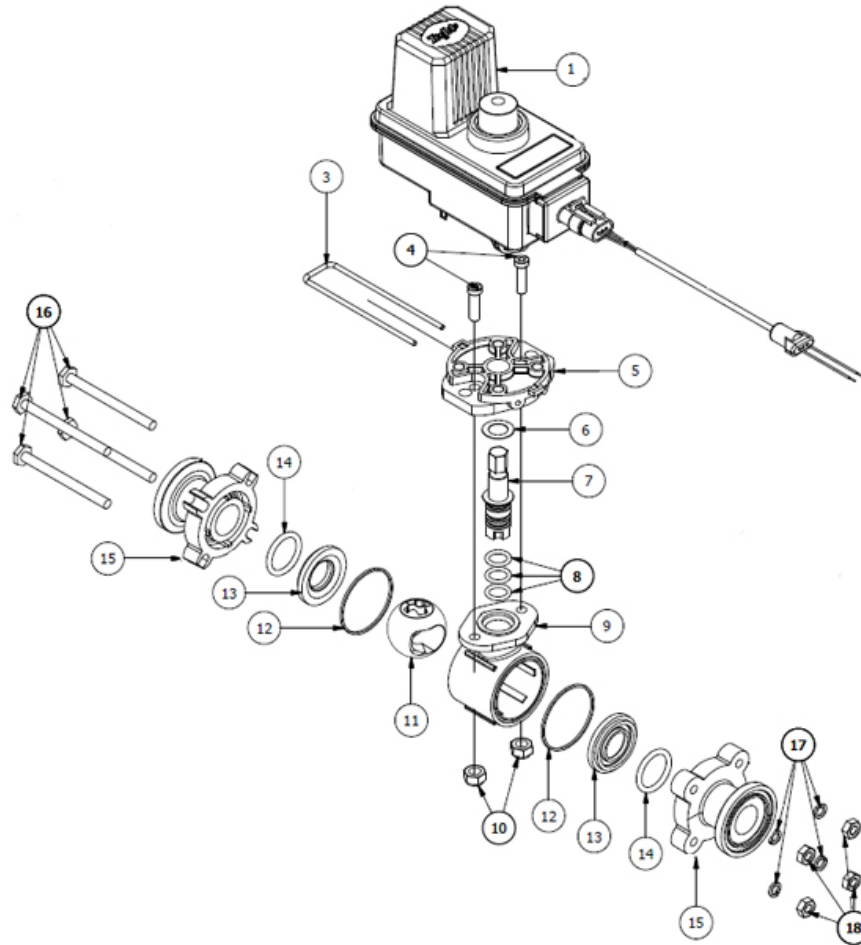

REF#	PART#	DESCRIPTION	QUANTITY
1	20-685-01	Motor	
3	15-552-24	Retaining Clip	1
4	15-552-25	Socket Head Cap Screw, Stainless Steel	2
5	15-552-26	Motor Adapter, Polypropylene	1
6	15-517-11	Thrust Washer, Teflon	1
7	15-552-27	Stem, Stainless Steel	1
8*	15-552-05	O-ring, Viton	3
9	15-517-16	Body, Nylon	1
10		Nylon Lock Nut, Stainless Steel	2
11		Ball, Polypropylene	1
12	15-552-13	Gasket, Viton	2
13	15-517-19	Seal, Teflon	2
14	15-517-20	O-ring, Viton	2
15	15-743-01	End Cap	1
16		SS Hex Bolt, 1/4 - 20 x 3	4
17		SS Lock Washer, 1/4	4
18		SS Nut, 1/4 - 20	4

20-685

Complete Regulator Valve

# 17-585 18' HD SUPER BOOM DRAWING

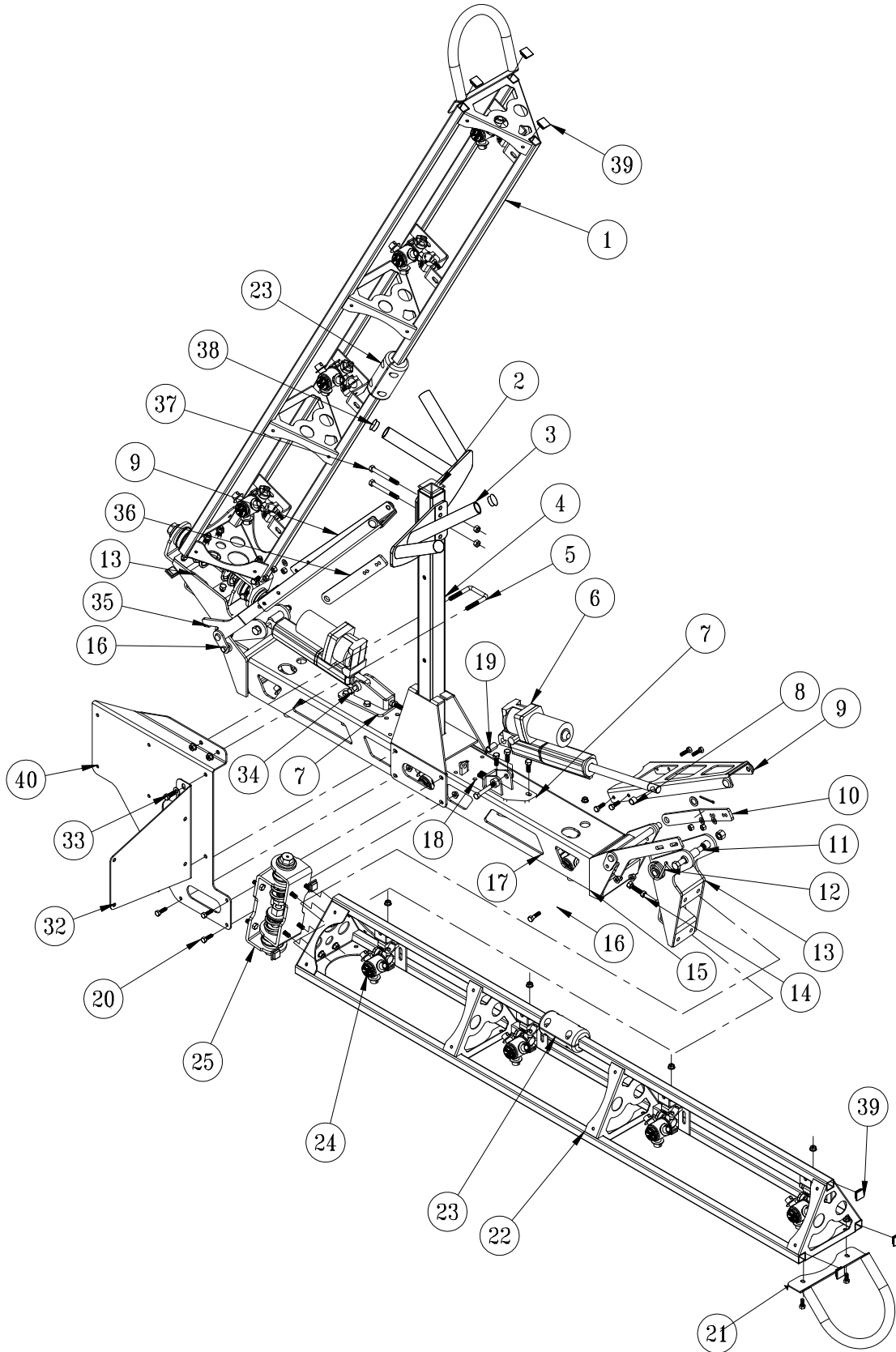

Accessories

# 17-585 18' HD SUPER BOOM PARTS LIST

REF#	PART#	DESCRIPTION	QUANTITY
1	17-531	Left Boom Arm	1
2	18-297	Cap Plug	1
3	17-617	Boom Nest	2
4	17-578	Boom Nest Post	1
5	17-537	Square U-Hex Bolt	1
6	30-214	KYB Electric/ Hydraulic Actuator (includes * items)	2
7	30-184	Ram Mount	2
	HN-38-16	Hex Nut, $\frac{3}{8}$ - 16 ( for adjustment Hex Bolts)	4
	HB-38-16-100	Hex Bolt, $\frac{3}{8}$ - 16 x 1	6
	HW-38	Flat Washer, $\frac{3}{8}$	6
	HNFL-38-16	Flange Whiz-loc Nut, $\frac{3}{8}$ -16	6
8*	18-036	$\frac{1}{2}$ " Bushing (part of 30-214)	2
9	17-587	Boom Lock	2
	HB-516-18-100	Hex Bolt, $\frac{5}{16}$ - 18 x 1	8
	HW-516	Flat Washer, $\frac{5}{16}$	4
	HNTL-516-18	Nylon Lock Nut, $\frac{5}{16}$ -18	8
	42-116	Rubber Insert	4
	8803-2.75	Trim Lace, 2.75"	2
10	17-588	Lock Hinge, RH	1
11	HB-12-13-500	Hex Bolt, $\frac{1}{2}$ - 13 x 5	2
	HNTL-12-13	Nylon Lock Nut, $\frac{1}{2}$ - 13	2
12	17-597	Torsion Spring, RH	1
13	30-185	Arm Pivot Hinge	2
	HG-14-28-180	Grease Fitting, $\frac{1}{4}$ - 28 x 180°	2
	76-128	Bushing (part of 30-185)	4
14	HB-38-16-175	Hex Bolt, $\frac{3}{8}$ - 16 x $1\frac{3}{4}$	2
	HNFL-38-16	Flange Whiz-loc Nut, $\frac{3}{8}$ - 16	4
15	17-589	Limit Hinge, RH	1
16	17-596	Hinge Pin w/ Spacer	2
	HP-18-100	Cotter Pin, $\frac{1}{8}$ x 1	2
	HB-516-18-100	Hex Bolt, $\frac{5}{16}$ - 18 x 1	2
	HNFL-516-18	Flange Whiz-loc Nut, $\frac{5}{16}$ -18	2
17	17-528	Boom Center	1
19*	18-234	1" Bushing (part of 30-214)	2
20	HB-516-18-100	Hex Bolt, $\frac{5}{16}$ - 18 x 1	8
	HW-516	Washer, $\frac{5}{16}$	8
	HNFL-516-18	Flange Whiz-loc Nut, $\frac{5}{16}$ - 18	8
21	17-541	Boom End Guard	2
	HBFL-516-18-075	Hex Bolt, $\frac{5}{16}$ - 18 x $\frac{3}{4}$	4
	HNFL-516-18	Flange Whiz-loc Nut, $\frac{5}{16}$ - 18	4
22	17-532	Right Boom Arm	1
23	17-573	Guide Block Set	2
	HB-14-20-125	Hex Bolt, $\frac{1}{4}$ - 20 x $1\frac{1}{4}$	8
	HNTL-14-20	Nylon Lock Nut, $\frac{1}{4}$ - 20	8
24	33-506	Body	11
	HB-516-18-075	Hex Bolt, $\frac{5}{16}$ -18 x $\frac{3}{4}$	11
	HNTL-516-18	Nylon Lock Nut, $\frac{5}{16}$ -18	11
25	17-632	Boom Hinge Complete	2
	HB-38-16-100	Hex Bolt, $\frac{3}{8}$ - 16 x 1	16
	HNFL-38-16	Nylon Lock Nut, $\frac{3}{8}$ - 16	16

(Continue on next page)

# 17-585 18' HD SUPER BOOM DRAWING

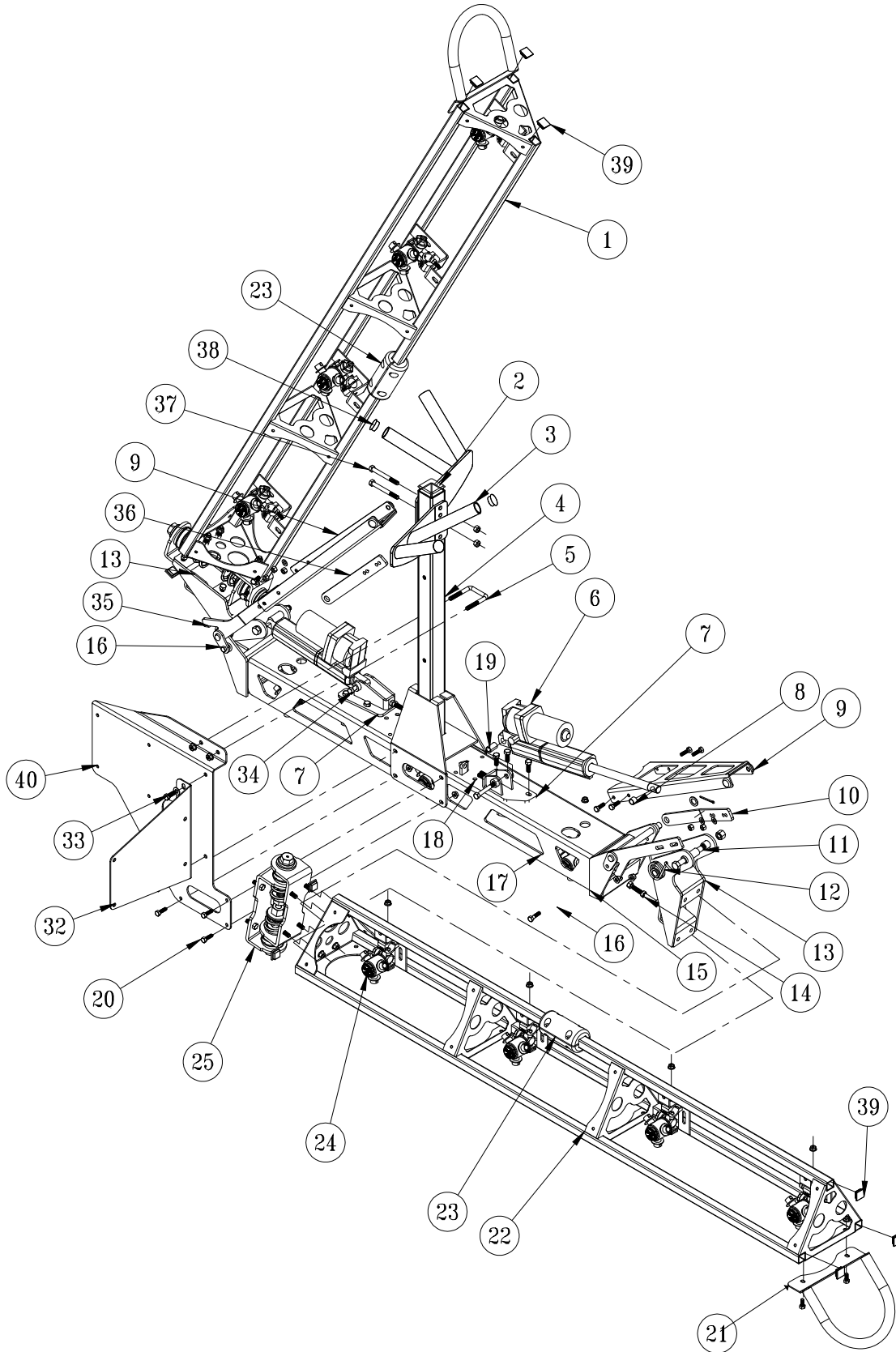

Accessories

## 17-585 18' HD SUPER BOOM PARTS LIST

REF#	PART#	DESCRIPTION	QUANTITY
32	17-636	Fresh Water Tank Mount	1
33	HB-38-16-100	Hex Bolt, $\frac{3}{8}$ - 16 x 1	2
	HNFL-38-16	Flange Whiz-loc Nut, $\frac{3}{8}$ - 16	2
	HW-38	Washer, $\frac{3}{8}$	2
34	HB-12-13-300	Hex Bolt, $\frac{1}{2}$ - 13 x 3	2
	HNTL-12-13	Nylon Lock Nut, $\frac{1}{2}$ - 13	2
35	17-593	Limit Hinge, LH	1
	17-598	Torsion Spring, LH	1
36	17-592	Lock Hinge, LH	1
37	HB-38-16-300	Hex Bolt, $\frac{3}{8}$ - 16 x 3	2
	HNTL-38-16	Nylon Lock Nut, $\frac{3}{8}$ - 16	2
38	17-619	Tube Cap	4
39	30-258	Ribbed 1" Plug	10
40	17-635	Clean Load Mount	1
	8803-13	Black Trim, 13"	1

## BOOM MOUNT TO TRUCK

REF#	PART#	DESCRIPTION	QUANTITY
A		Center Boom Mount	1
B	17-614	Boom Spacer	2
C	HB-516-18-100	Hex Bolt, $\frac{5}{16}$ -18 x 1	12
	HNTL-516-18	Nylon Lock Nut, $\frac{5}{16}$ -18	12
D	20-555	U-Hex Bolt	4
	HNFL-12-13	Flange Whiz-loc Nut, $\frac{1}{2}$ - 13	8

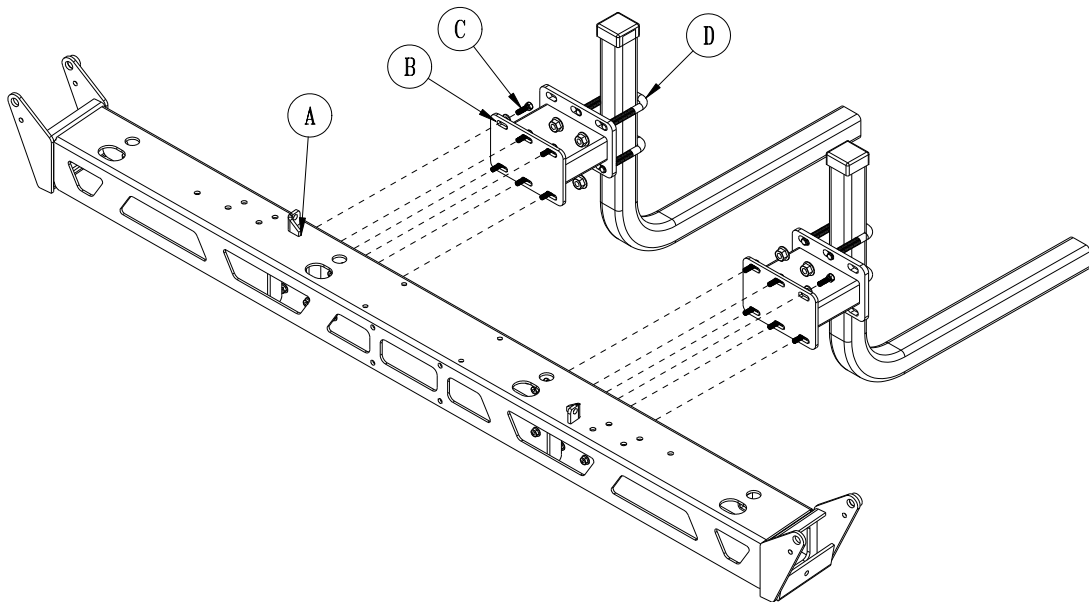

# 17-585 18' HD SUPER BOOM PLUMBING

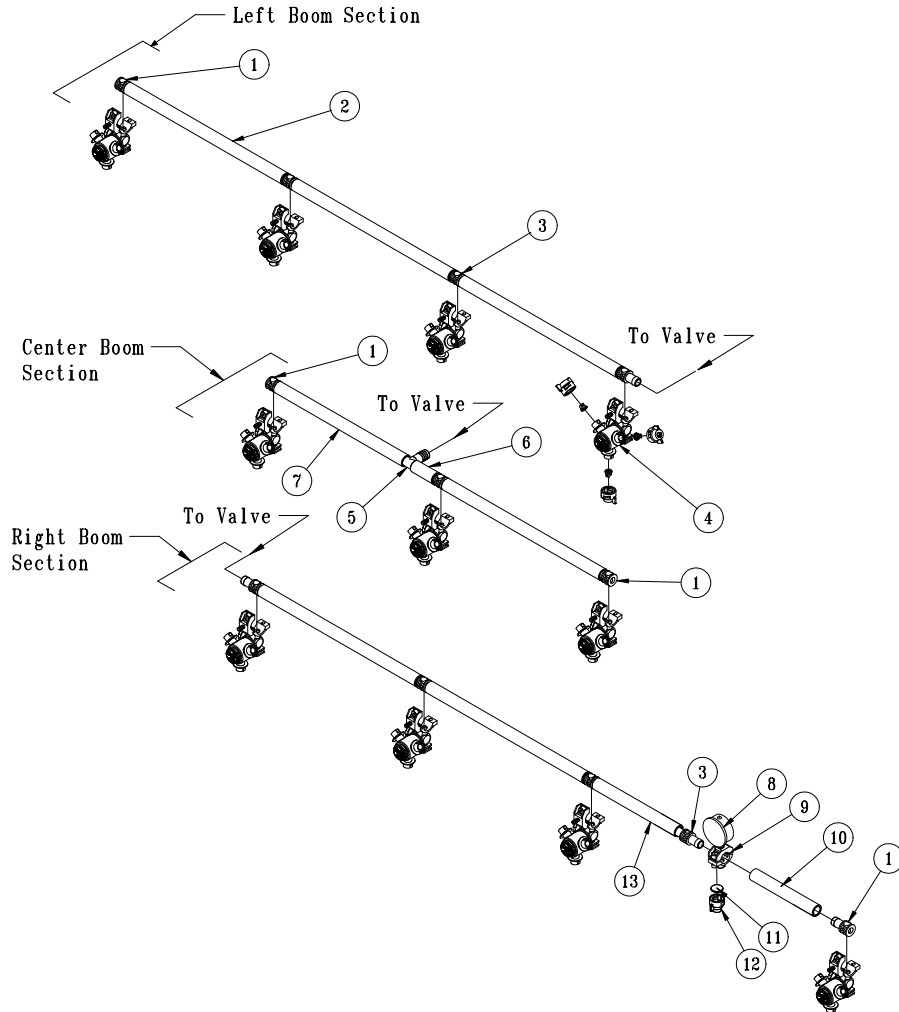

REF#	PART#	DESCRIPTION	QUANTITY
1	18-417	Single Barb	4
2	9032-19	Black Hose $\frac{3}{4}$ " x 19"	6
	18-040	Hose Clamp	12
3	18-416	Double Barb	8
4	33-506	Nozzle body (see nozzle drawing)	11
5	18-415	$\frac{3}{4}$ " Hose Barb	1
6	9032-2.5	Black Hose $\frac{3}{4}$ " x 2 $\frac{1}{2}$ "	1
	18-040	Hose Clamp	2
7	9032-15.5	Black Hose $\frac{3}{4}$ " x 15 $\frac{1}{2}$ "	1
	18-040	Hose Clamp	2
8	16-281	Gauge	1
9	17-602	Nozzle Body	1
10	9032-5	Black Hose $\frac{3}{4}$ " x 5"	1
	18-040	Hose Clamp	2
11	16-800	Strainer	1
12	16-921	Nozzle	1
13	9032-13	Black Hose $\frac{3}{4}$ " x 13"	1
	18-040	Hose Clamp	2



# 17-585 18' HD SUPER BOOM PLUMBING FOR DYNAJET®

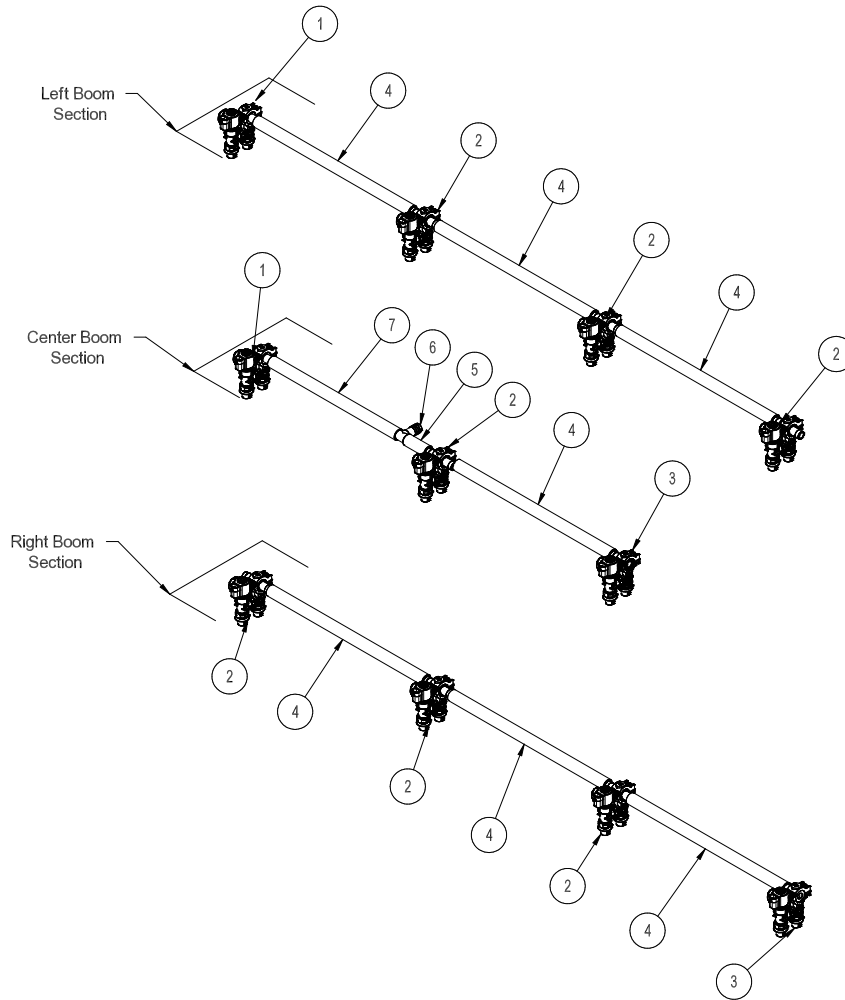

REF#	PART#	DESCRIPTION	QUANTITY
1	20-675	Single Hose Barb - Right Orientation	2
2	20-673	Single Hose Barb	7
3	20-674	Single Hose Barb - Left Orientation	2
4	9032-19	Black Hose, $\frac{3}{4}$ " x 19"	7
	18-040	Hose Clamp	14
5	9032-2.5	Black Hose, $\frac{3}{4}$ " x 2 $\frac{1}{4}$ "	1
	18-040	Hose Clamp	2
6	18-415	$\frac{3}{4}$ " Hose Barb	1
7	9032-15.5	Black Hose, $\frac{3}{4}$ " x 15 $\frac{1}{4}$ "	1
	18-040	Hose Clamp	2

# 17-580 20' HD SUPER BOOM DRAWING

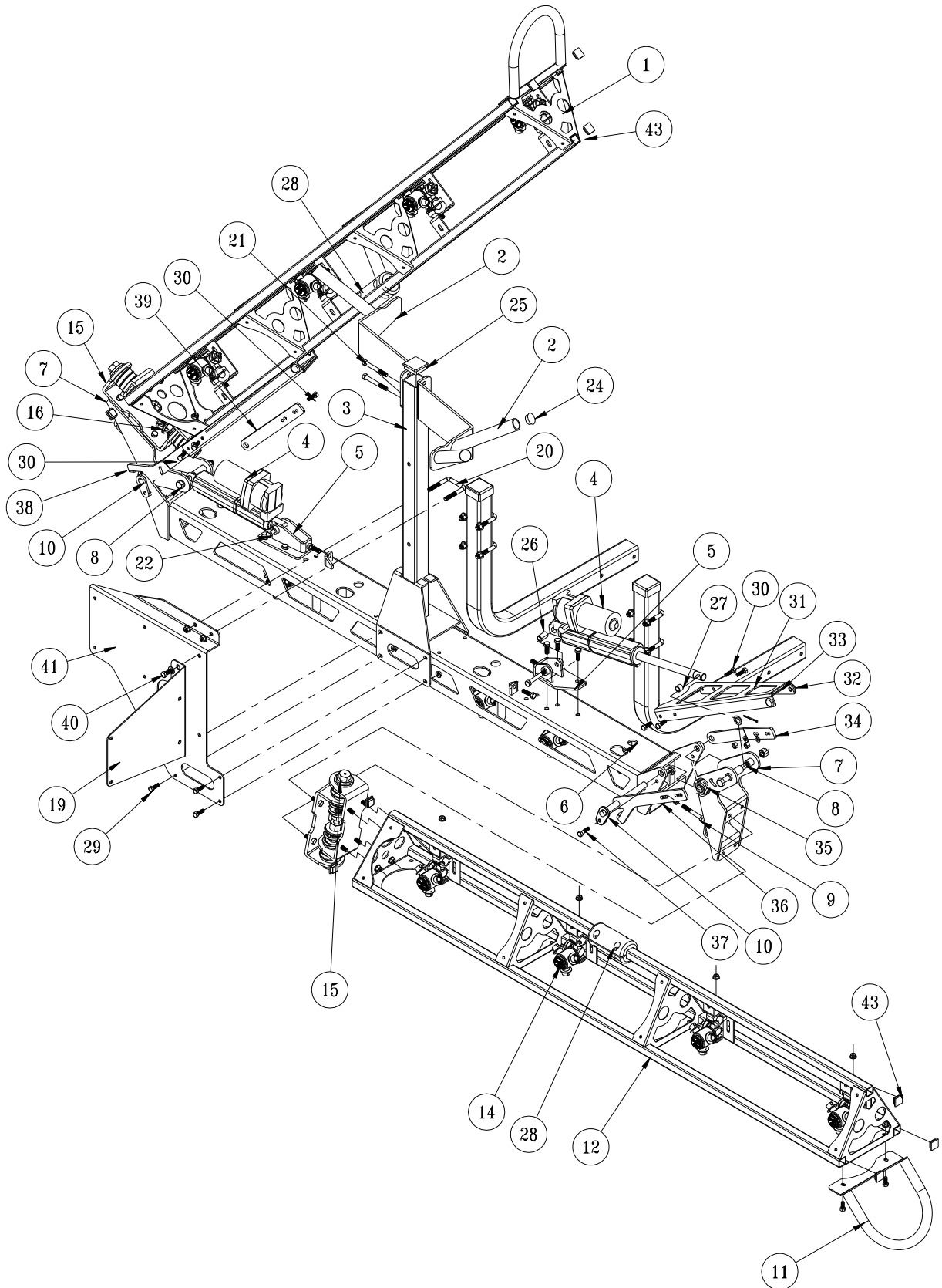

Accessories

## 17-580 20' HD SUPER BOOM PARTS LIST

REF#	PART#	DESCRIPTION	QUANTITY
1	17-531	Left Boom Arm	1
2	17-631	V-Boom Nest	2
3	17-578	Boom Nest Post	1
4	30-214	10" Electric Hydraulic Actuator	2
5	30-184	Actuator Mount	2
	HN-38-16	Hex Nut, $\frac{3}{8}$ - 16 (adjustment Hex Bolt)	4
	HB-38-16-100	Hex Bolt, $\frac{3}{8}$ - 16 x 1	6
	HW-38	Flat Washer, $\frac{3}{8}$	6
	HNFL-38-16	Flange Whiz-loc Nut, $\frac{3}{8}$ -16	6
6	17-579	Boom Center	1
7	30-185	Arm Pivot Hinge	2
	HG-14-28-180	Grease Fitting, $\frac{1}{4}$ - 28 x 180°	2
	76-128	Bushing	4
8	HB-12-13-500	Hex Bolt, $\frac{1}{2}$ - 13 x 5	2
	HNTL-12-13	Nylon Lock Nut, $\frac{1}{2}$ - 13	2
9	HB-38-16-175	Hex Bolt, $\frac{3}{8}$ - 16 x $1\frac{3}{4}$	2
	HNFL-38-16	Flange Whiz-loc Nut, $\frac{3}{8}$ -16	4
10	17-596	Hinge Pin w/Spacer	2
	HP-18-100	Cotter Pin, $\frac{1}{8}$ x 1	2
11	17-541	Boom End Guard	2
	HBFL-516-18-075	Hex Bolt, $\frac{5}{16}$ - 18 x $\frac{3}{4}$	4
	HNFL-516-18	Flange Whiz-loc Nut, $\frac{5}{16}$ - 18	4
12	17-532	Right Boom Arm	1
14	33-506	Body (see nozzle drawing)	12
	HB-516-18-075	Hex Bolt, $\frac{5}{16}$ -18 x $\frac{3}{4}$	12
	HNTL-516-18	Nylon Lock Nut, $\frac{5}{16}$ -18	12
15	17-632	Boom Hinge Complete	2
	HB-38-16-100	Hex Bolt, $\frac{3}{8}$ - 16 x 1	16
	HNFL-38-16	Nylon Lock Nut, $\frac{3}{8}$ - 16	16
19	17-636	Fresh Water Tank Mount	1
20	17-537	Square U-Hex Bolt	1
21	HB-38-16-300	Hex Bolt, $\frac{3}{8}$ - 16 x 3	2
	HNTL-38-16	Nylon Lock Nut, $\frac{3}{8}$ - 16	2
22	HB-12-13-300	Hex Bolt, $\frac{1}{2}$ - 13 x 3	2
	HNTL-12-13	Nylon Lock Nut, $\frac{1}{2}$ - 13	2
24	17-619	Push in Plug	4
25	18-297	Cap Plug	1
26	18-036	1" Bushing (part of 30-216)	2
27	18-234	$\frac{1}{2}$ " Bushing (part of 30-216)	2
28	17-573	Guide Block Set	2
	HB-14-20-125	Hex Bolt, $\frac{1}{4}$ -20 x $1\frac{1}{4}$	8
	HNTL-14-20	Nylon Lock Nut, $\frac{1}{4}$ - 20	8
29	HB-516-18-075	Hex Bolt, $\frac{5}{16}$ - 18 x $\frac{3}{4}$	8
	HW-516	Flat Washer, $\frac{5}{16}$	8
	HNFL-516-18	Flange Whiz-loc Nut, $\frac{5}{16}$ - 18	8
30	HB-516-18-100	Hex Bolt, $\frac{5}{16}$ -16 x 1	8
	HW-516	Flat Washer, $\frac{5}{16}$	4
	HNTL-516-18	Nylon Lock Nut, $\frac{5}{16}$ - 18	8

(Continue on next page)

# 17-580 20' HD SUPER BOOM DRAWING

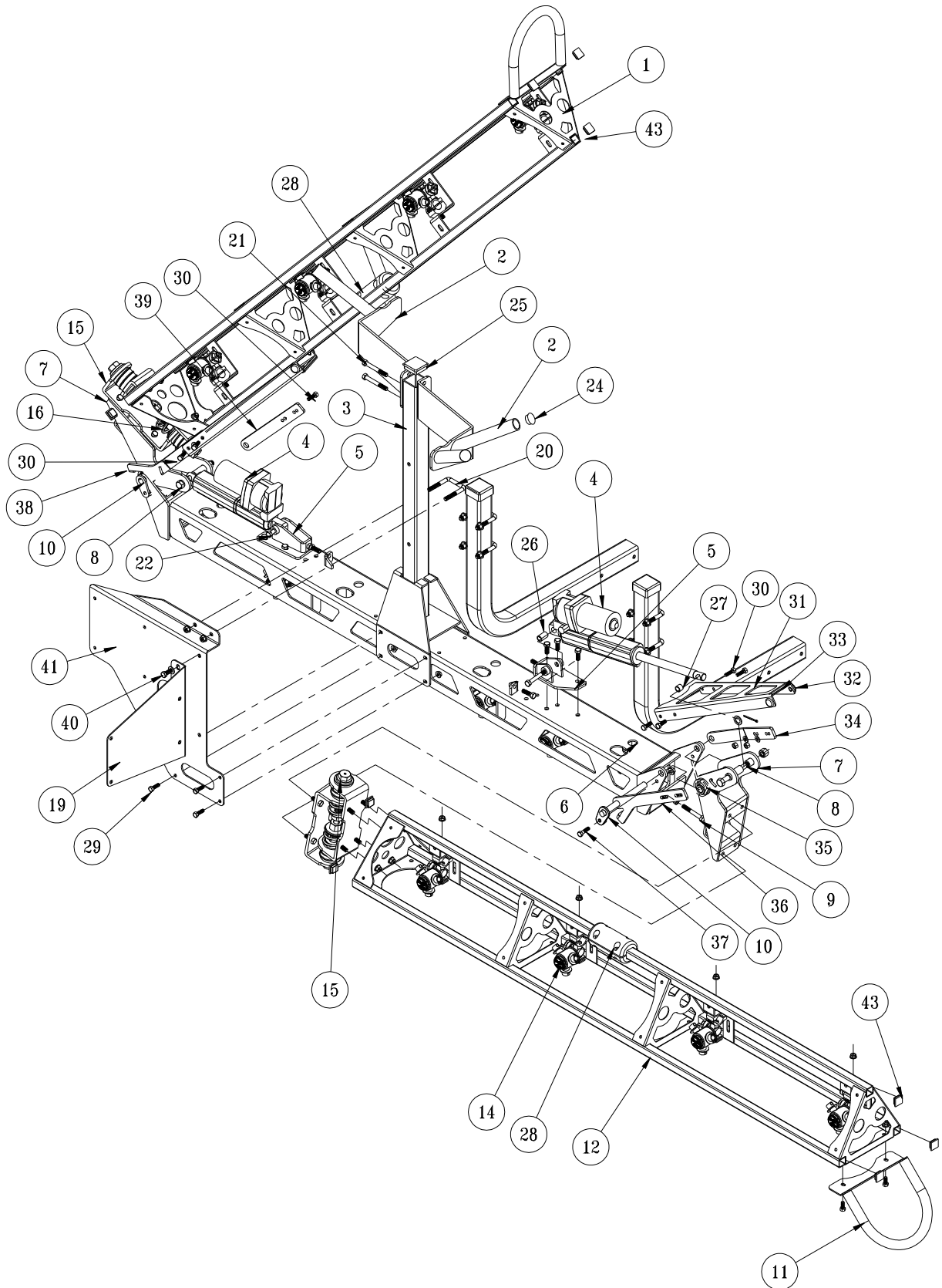

Accessories

## 17-580 20' HD SUPER BOOM PARTS LIST

REF#	PART#	DESCRIPTION	QUANTITY
31	17-587	Boom Lock	2
32	42-116	Rubber Insert	4
33	8803-2.75	Trim Lace, 2 <sup>3</sup> / <sub>4</sub>	2
34	17-588	Lock Hinge, RH	1
35	17-597	Torsion Spring, RH	1
36	17-589	Limit Hinge, RH	1
37	HB-516-18-100	Hex Bolt, <sup>5</sup> / <sub>16</sub> -16 x 1	2
	HNFL-516-18	Flange Whiz-loc Nut, <sup>5</sup> / <sub>16</sub> - 18	2
38	17-593	Limit Hinge, LH	1
	17-598	Torsion Spring, LH	1
39	17-592	Lock Hinge, LH	1
40	HB-38-16-100	Hex Bolt, <sup>3</sup> / <sub>8</sub> - 16 x 1	2
	HNFL-38-16	Flange Whiz-loc Nut, <sup>3</sup> / <sub>8</sub> - 16	2
	HW-38	Washer, <sup>3</sup> / <sub>8</sub>	2
41	17-635	Clean Load Mount	1
	8803-13	Black Trim, 13"	1
43	30-258	1" 10-14ga Ribbed Plug	10

## BOOM MOUNT TO TRUCK

REF#	PART#	DESCRIPTION	QUANTITY
A		Center Boom Mount	1
B	17-614	Boom Spacer	2
C	HB-516-18-100	Hex Bolt, <sup>5</sup> / <sub>16</sub> -18 x 1	12
	HNTL-516-18	Nylon Lock Nut, <sup>5</sup> / <sub>16</sub> -18	12
D	20-555	U-Hex Bolt	4
	HNFL-12-13	Flange Whiz-loc Nut, <sup>1</sup> / <sub>2</sub> - 13	8

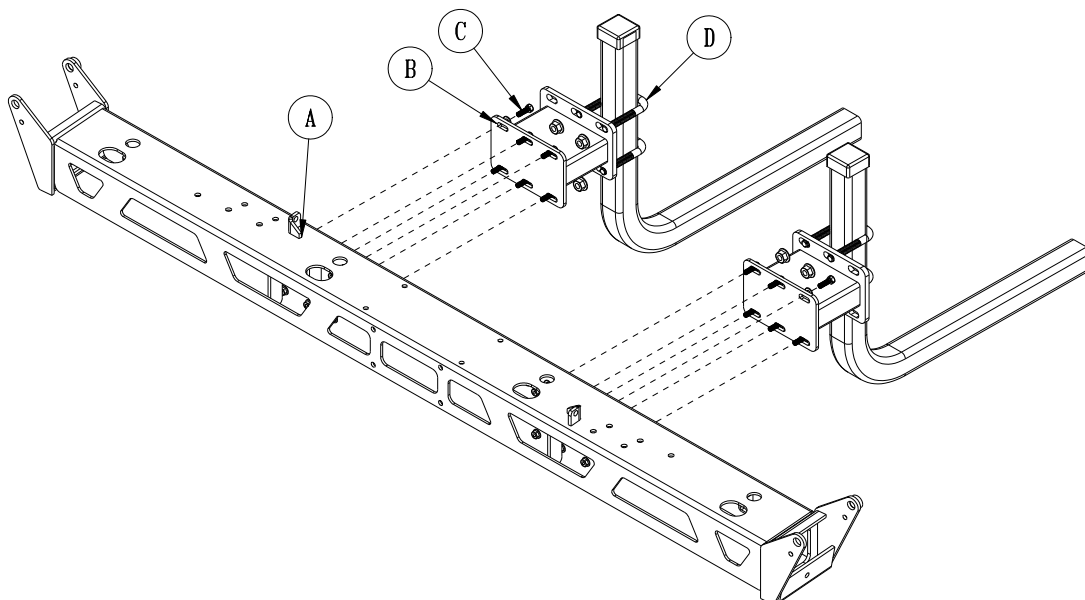

# 17-580 20' HD SUPER BOOM PLUMBING

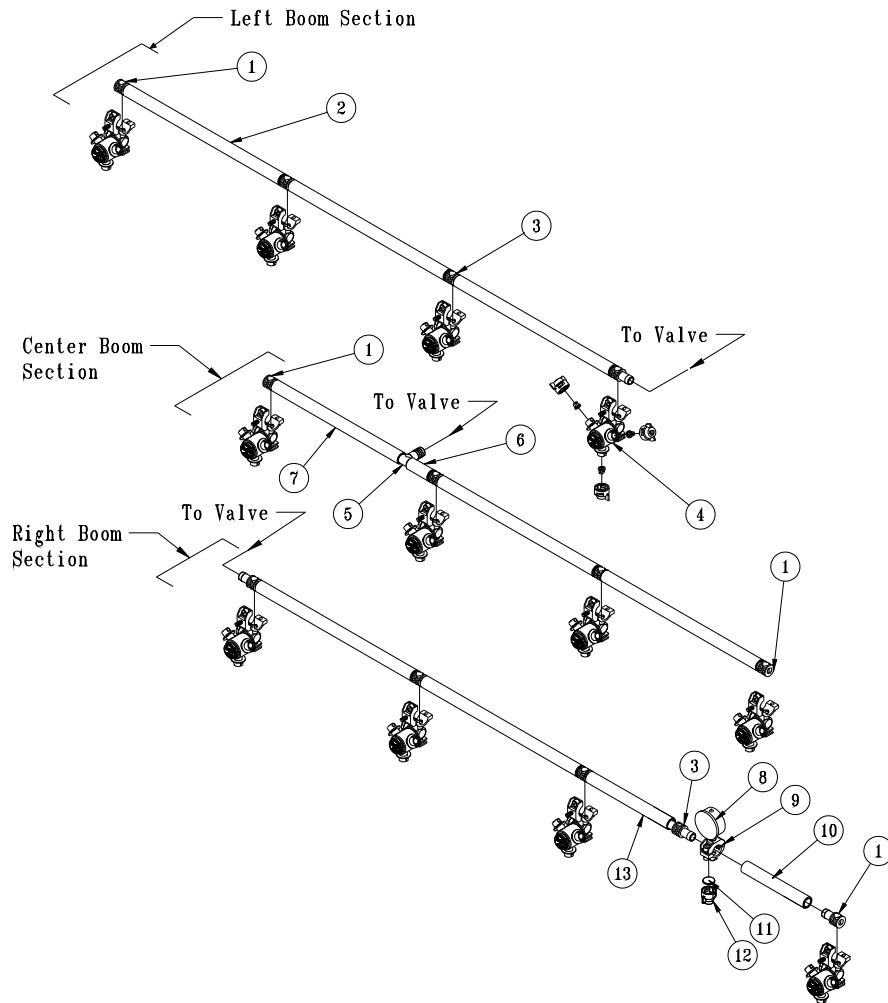

REF#	PART#	DESCRIPTION	QUANTITY
1	18-417	Single Barb	4
2	9032-19	Black Hose $\frac{3}{4}$ " x 19"	7
	18-040	Hose Clamp	14
3	18-416	Double Barb	9
4	33-506	Nozzle body (see nozzle drawing)	12
5	18-415	$\frac{3}{4}$ " Hose Barb	1
6	9032-2.5	Black Hose $\frac{3}{4}$ " x 2 $\frac{1}{2}$ "	1
	18-040	Hose Clamp	2
7	9032-15.5	Black Hose $\frac{3}{4}$ " x 15 $\frac{1}{2}$ "	1
	18-040	Hose Clamp	2
8	16-281	Gauge	1
9	17-602	Nozzle Body	1
10	9032-5	Black Hose $\frac{3}{4}$ " x 5"	1
	18-040	Hose Clamp	2
11	16-800	Strainer	1
12	16-921	Nozzle	1
13	9032-13	Black Hose $\frac{3}{4}$ " x 13"	1
	18-040	Hose Clamp	2

# 17-580 20' HD SUPER BOOM PLUMBING FOR DYNAJET®

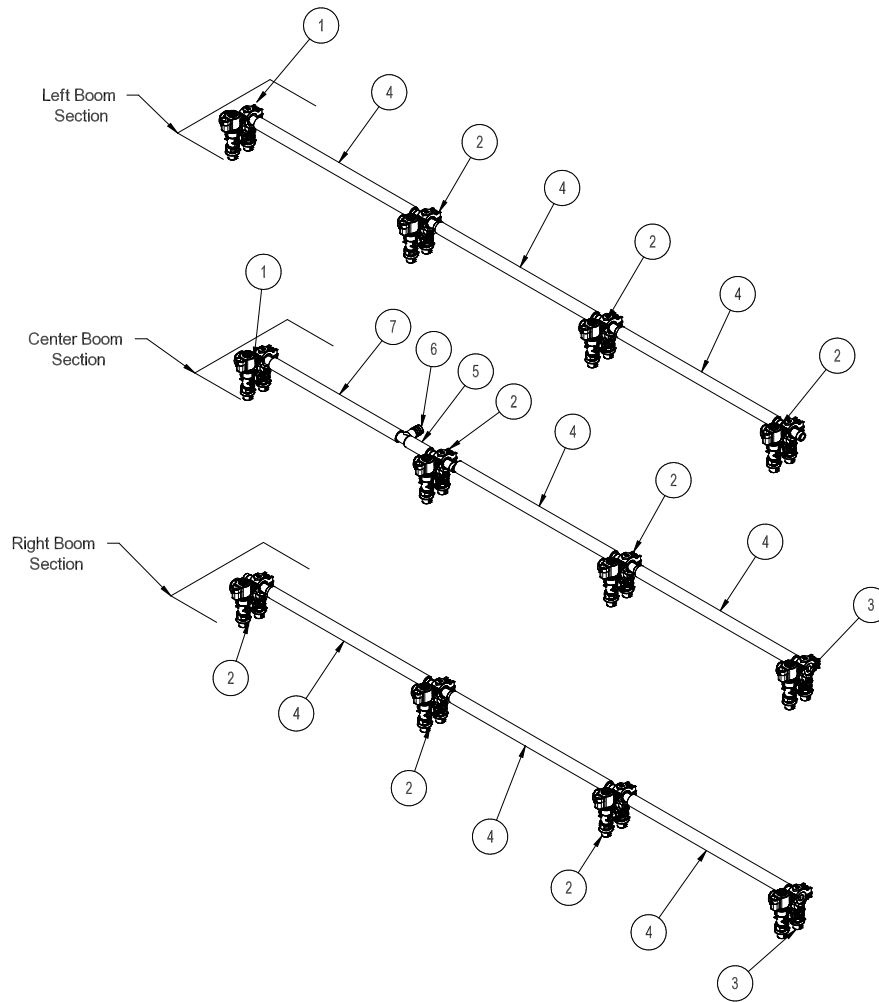

REF#	PART#	DESCRIPTION	QUANTITY
1	20-675	Single Hose Barb - Right Orientation	2
2	20-673	Single Hose Barb	8
3	20-674	Single Hose Barb - Left Orientation	2
4	9032-19	Black Hose $\frac{3}{4}$ " x 19"	8
	18-040	Hose Clamp	16
5	9032-2.5	Black Hose $\frac{3}{4}$ " x 2 $\frac{1}{2}$ "	1
	18-040	Hose Clamp	2
6	18-415	$\frac{3}{4}$ " Hose Barb	1
7	9032-15.5	Black Hose $\frac{3}{4}$ " x 15 $\frac{1}{2}$ "	1
	18-040	Hose Clamp	2

Accessories

# QJS NOZZLE DRAWING

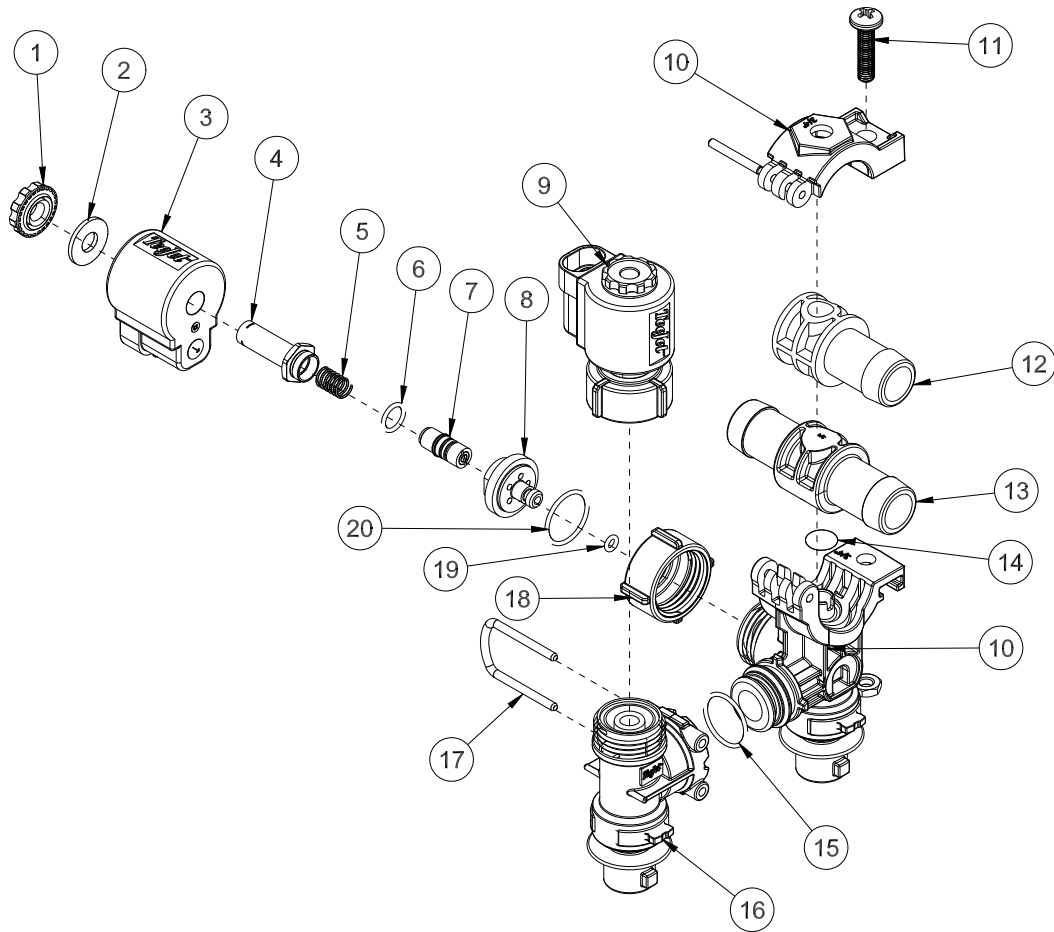

REF#	PART#	DESCRIPTION	QUANTITY
1		Nylon Black Nut	1
2		303 Stainless Steel Washer	1
3	20-673-09	12V Coil Assembly	1
4		Tube Sub Assembly	1
5*		302 Stainless Steel Spring	1
6*		Viton Oring	1
7*		Plunger	1
8		303 Stainless Steel Cap	1
9	20-673-02	E-Chemsaver Solenoid	1
10	20-673-04	3/4" Mount Assembly	1
11		Pan Head Screw	1
12	18-417	Single Barb (part of 20-674-P and 20-675-P)	1
13	18-416	Double Barb (part of 20-673-P)	1
14		Oring	1
15		Oring	1
16	20-673-05	End Body Sub-assembly	1
17		Retaining Clip	1
18		Locking Ring	1
19*	20-673-07	Viton Oring	1
20*	20-673-06	Viton Gasket	1
*	20-673-01	Spare Parts Kit	



# QJS BOTTOM MOUNT NOZZLE ASSEMBLY

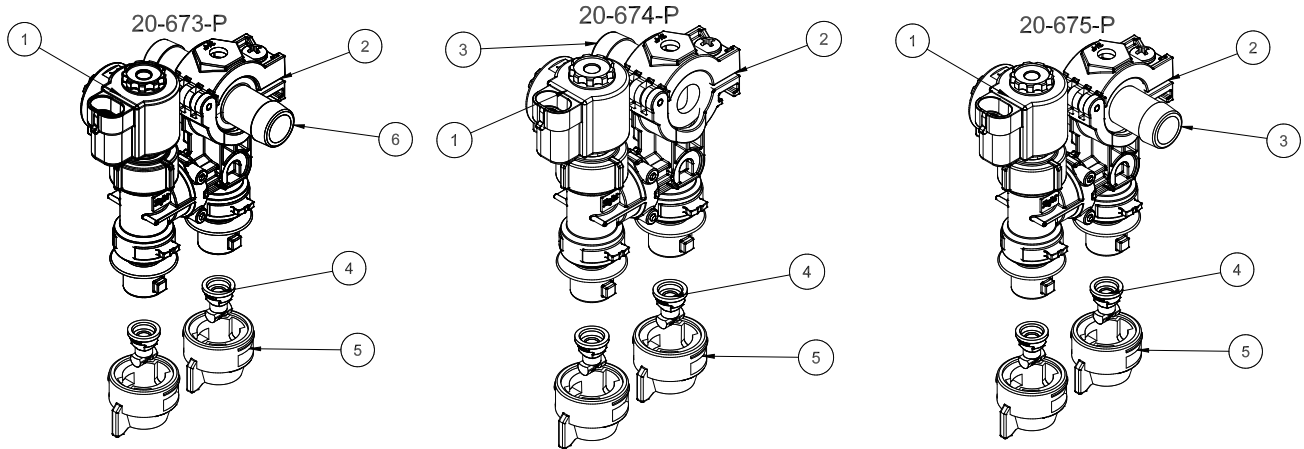

REF#	PART#	DESCRIPTION	QUANTITY
1*	20-673-02	E-Chemsaver®	1
2*	20-673-04	3/4" Bottom Mount Nozzle Body	1
3†	18-417	Single Barb	1
4	20-676	Turbo TeeJet Tip	2
5	20-677	QT White Cap and Washer	2
6‡	18-416	Double Hose Barb	1

Quantity is per nozzle body. For 18' booms multiply quantity by 11.  
 Quantity is per nozzle body. For 20' booms multiply quantity by 12.

20-673	Double Hose Barb Nozzle (includes * and ‡ item)	8 or 9
20-674	Single Hose Barb Left Orientation (includes * and † item)	2
20-675	Single Hose Barb - Right Orientation (includes * and † item)	2

Nozzles are located 20" (51 cm) apart on the right, left, and center tubes. Nozzles are 20" high off ground.

# TRIPLE NOZZLE ASSEMBLY DRAWING

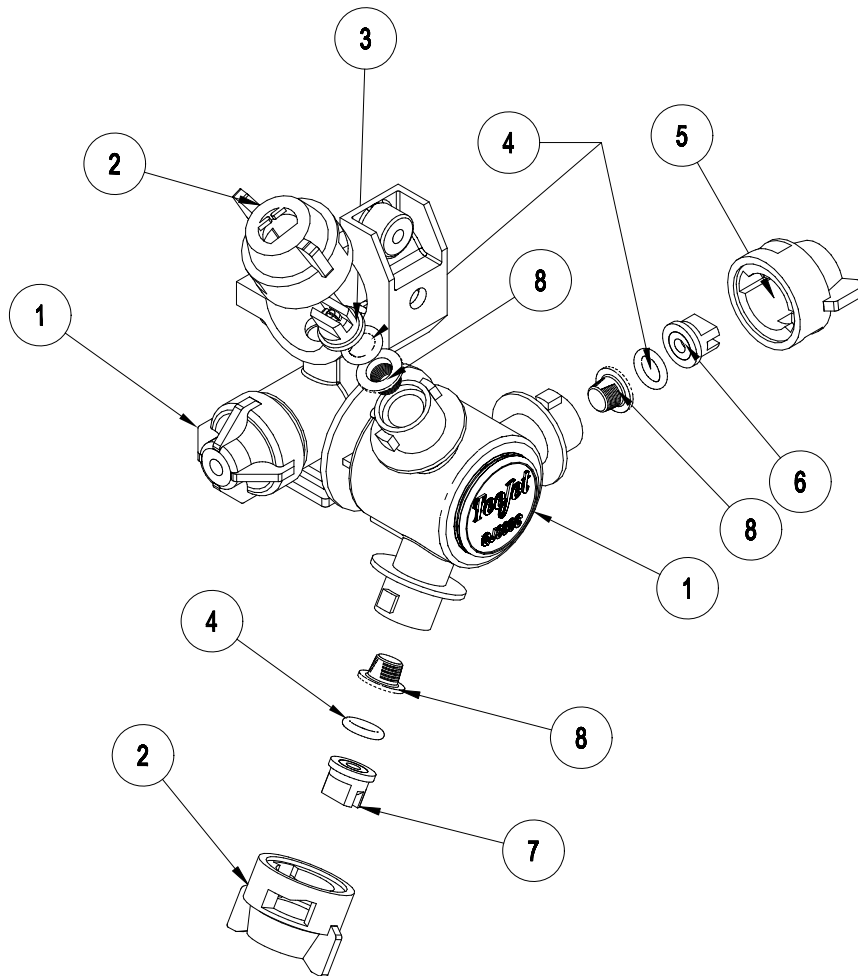

REF#	PART#	DESCRIPTION	QUANTITY
1	33-506	Body	1
2	33-538	Cap - Gray	2
3	33-553	Nozzle -Gray (XR11006-VS)	1
4	16-800	Viton Gasket	3
5	33-537	Cap - Red	1
6	33-552	Nozzle - Red (XR11004-VS)	1
7	33-554	Nozzle - White (XR11008-VS)	1
8	16-802	Strainer	3

Quantity is per nozzle body. For 20' booms multiply quantity by 12.

Quantity is per nozzle body. For 18' booms multiply quantity by 11.

Nozzles are located 20" (51 cm) apart on the right, left, and center tubes. There are predrilled holes in all tubes. The Nozzle should be at a 45° angle to the ground for proper application.

For re-ordering Nozzle Kits the following numbers apply

33-540 Triple Nozzle Kit for 18' Booms

33-542 Triple Nozzle Kit for 20' Booms

# 15-835 TANK RINSING SYSTEM

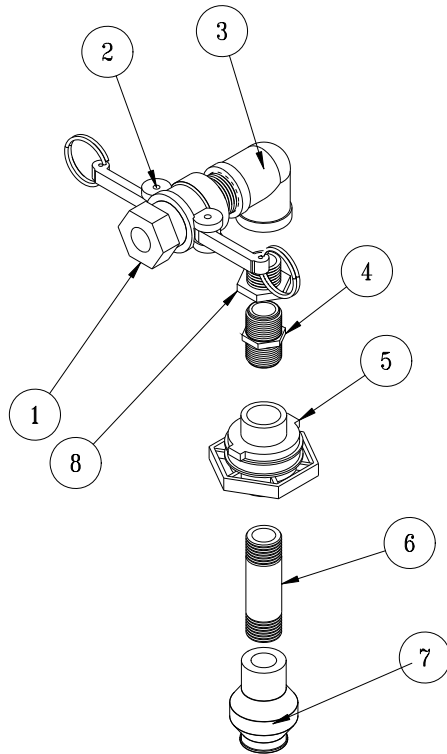

REF#	PART#	DESCRIPTION	QUANTITY
1	16-961	1" Adapter	1
2	16-962	1" Coupler	1
3	16-864	1" FTP Elbow	1
4	16-158	Close Nipple	1
5	16-150	Double Thread Fitting	1
6	16-172	4" Nipple	1
7	15-834	Tank Rinsing Nozzle	1
8	16-163	Reducer Bushing	1

Drill 1<sup>3</sup>/<sub>4</sub>" hole 5" from outside edge of cover.  
 Install Tank Rinsing kit as shown, with the Double Thread Fitting (Ref 5) going into the cover.

Basket Must be removed During Use.

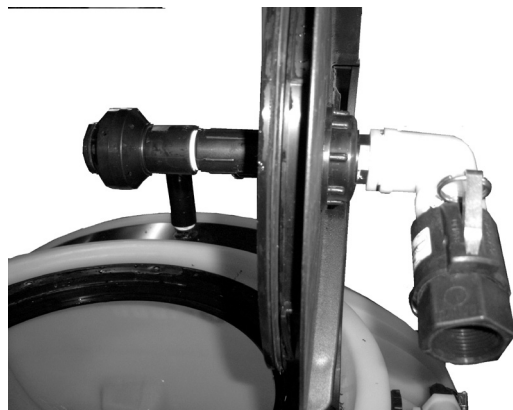

Accessories

# 16-906 ELECTRIC HOSE REEL DRAWING

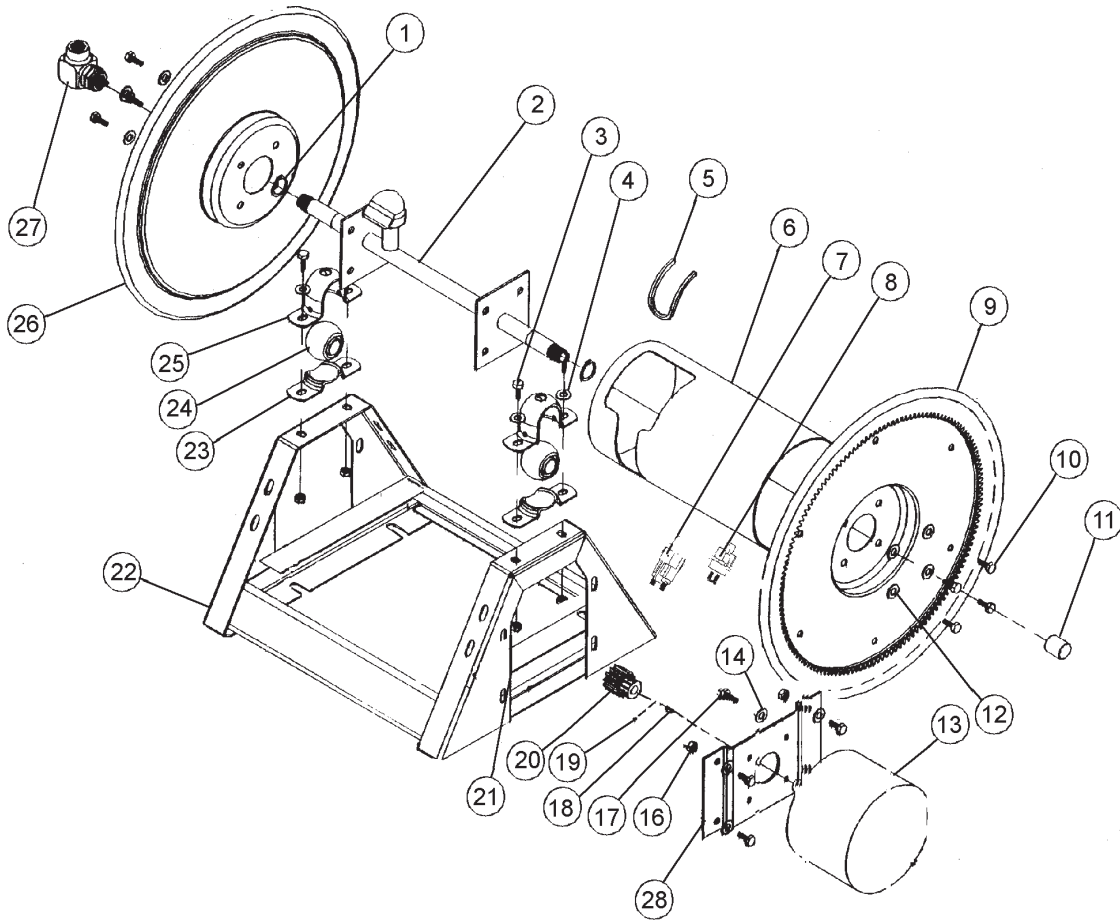

## 16-906ELECTRIC HOSE REEL PARTS LIST

REF#	PART#	DESCRIPTION	QUANTITY
1	16-906-25	Retaining Ring	2
2	16-906-22	Axle Assembly	1
3	HB-38-16-100	Hex Bolt, $\frac{3}{8}$ - 16 x 1	4
4	HW-38	Flat Washer, $\frac{3}{8}$	4
5	16-906-27	Trim, Drum Edge	1
6	16-906-21	Drum Center	1
7	13-750	Solenoid	1
	HB-14-20-075	Hex Bolt, $\frac{1}{4}$ - 20 x $\frac{3}{4}$	2
	HWL-14	Lock Washer, $\frac{1}{4}$	2
	HN-14-20	Hex Nut, $\frac{1}{4}$ - 20	2
8	33-251	Switch	1
9	16-906-19	Disc and Gear Assembly	1
10	HB-516-18-075	Hex Bolt, $\frac{5}{16}$ - 18 x $\frac{3}{4}$	8
11	16-906-26	Pipe Cap, $\frac{3}{4}$	1
12	HWL-516	Lock Washer, $\frac{5}{16}$	8
13		Motor 12VDC	1
14	HW-516	Flat Washer, $\frac{5}{16}$	4
16	HNTL-516-18	Nylon Lock Nut, $\frac{5}{16}$ - 18	4
17	HB-516-18-100	Hex Bolt, $\frac{5}{16}$ -18 x 1	4
18	16-906-17	Key	1
19		Set Screw	2
20	16-906-29	Pinion	1
21	HNTL-38-16	Nylon Lock Nut, $\frac{3}{8}$ - 16	4
22	16-906-18	Frame Assembly	1
23	16-906-08	Mounting Pillow Block (Bottom)	2
24	16-906-24	Bearing	2
25	16-906-07	Mounting Pillow Block (Top)	2
26	16-906-20	Disc, 17 $\frac{1}{2}$ "	1
27	16-906-23	Swivel Assembly, $\frac{3}{4}$	1
	16-906-30	Seal Kit (For 16-906-23)	1
28	16-906-28	Bracket 12VDC	1
	16-982	Electric Hose Reel (only)	1

# ELECTRIC HOSE REEL WIRING DIAGRAM

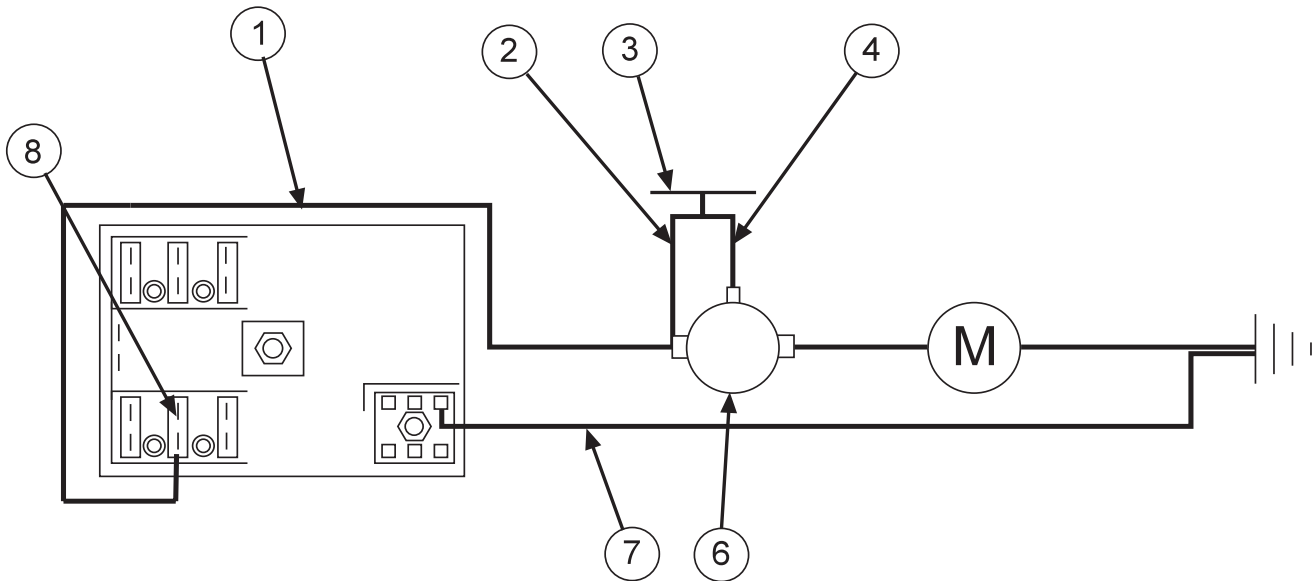

REF#	PART#	DESCRIPTION	QUANTITY
1	8843-132	Flex-guard $\frac{3}{8}$ ID	1
	8919-144	10GA Red Wire 144"	1
	8901	Slide-On Connector	1
2	16-979	Wire, Switch to Solenoid Hot Terminal	1
3	33-251	Push Button Switch	1
4	16-978	Wire, Switch to Solenoid Start Terminal	1
6	13-750	Solenoid	1

## SOLENOID TERMINALS

	HN -516-24	$\frac{5}{16}$ - 24 Hex Nut	2
	HN -10-32	10 - 32 Hex Nut	1
7	8931-144	10GA White Wire 144"	1
	8901	Slide-On Connector	1
8	33-273	Auto Blade Type Fuse 30Amp	1

## CONNECTION INSTRUCTIONS

Route wire harness along side of tank and over to fuse block taking care to stay clear of moving parts or hot engine components. Cut off excess wire and strip back  $\frac{3}{8}$ ". Place one 8963 heat shrink ( $\frac{1}{4} \times 1\frac{1}{4}$ ) on each wire before crimping 8901 slide on connectors to the red and white wires. Connect the two wires to the fuse block first the red to the (+) positive and the white to the (-) negative. Put the 33-273 auto blade type fuse (30 amp) into fuse block.

## ⚠ WARNING

Make certain you are connecting positive (+) to positive; negative (-) to negative while attaching power leads. If you do not observe polarity, damage will result to electrical components.

Use Dielectric Grease On All Electrical Connections

## HOSE REEL ADJUSTMENTS

### **OPERATIONAL CHECK:**

1. Pull hose off drum at least one full revolution. A clicking noise should be heard from locking mechanism.
2. Let the hose retract.
3. Pull the hose off until the first click is heard. Drum should lock when the hose tension is removed.
4. Continue pulling the hose, no more than one revolution, until no clicking is heard. Hose should rewind when tension is removed.

### **HOSE REPLACEMENT PROCEDURE:**

1. Facing swivel, turn the hose drum clockwise until all of the hose is removed from the drum and the drum is held by locking mechanism. Make sure spring is locked.
2. Remove hose clamps and disconnect hose from swivel. Remove old hose.
3. Insert new hose through roller guide, connect to swivel and reinstall hose clamps. Use spring guard over hose to protect the hose from being cut by the drum.
4. Remove check ball from old hose and install on replacement hose.
5. Carefully, keeping the tension on the hose, pull the hose to release the locking mechanism. Let the hose wind on the drum.

# 16-129 MANUAL HOSE REEL DRAWING

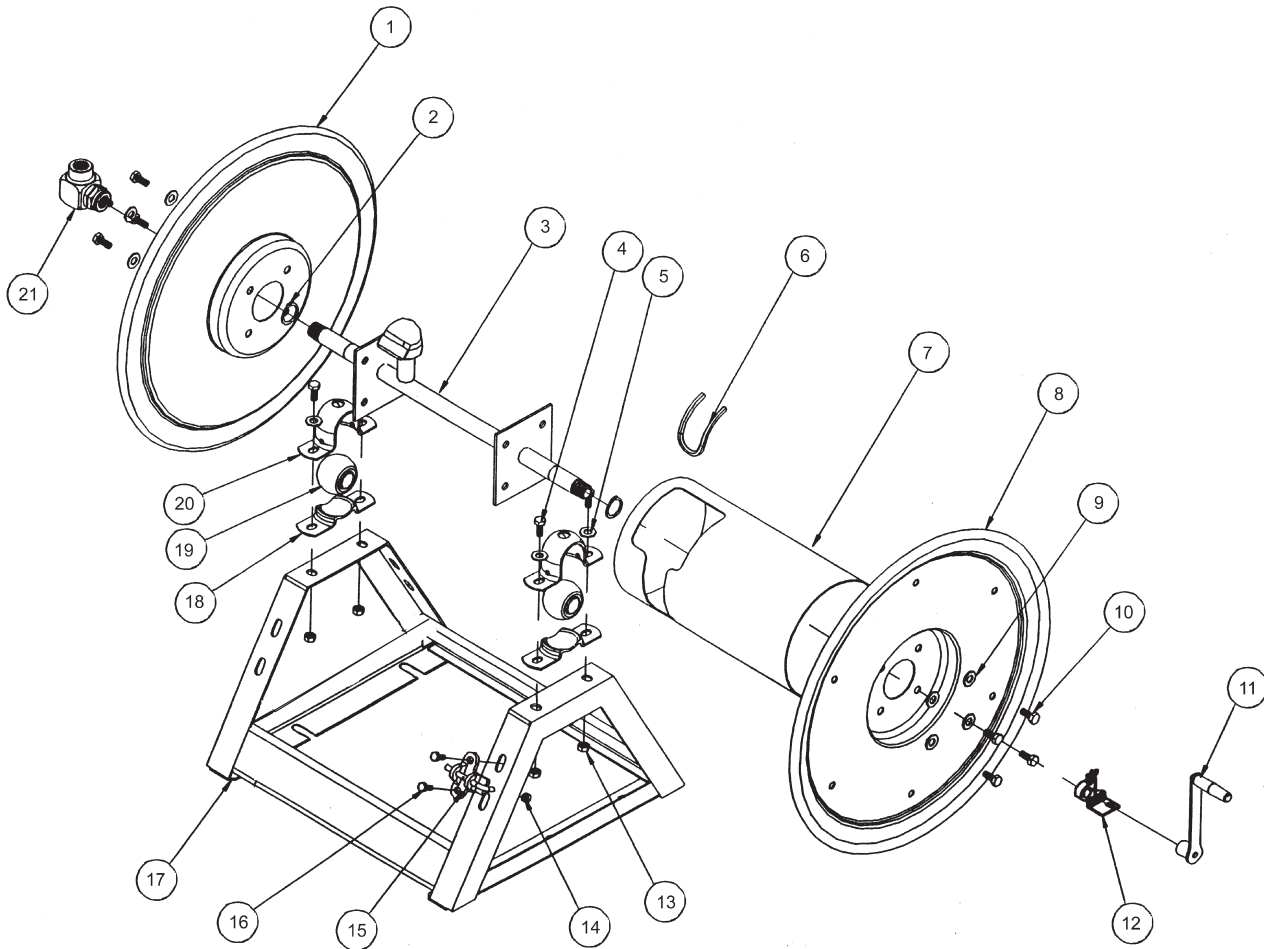

REF#	PART#	DESCRIPTION	QUANTITY
1	16-129-11	Disc 17 $\frac{1}{2}$	1
2	16-906-25	Retaining Ring	2
3	16-906-22	Axle Assembly $\frac{3}{4}$	1
4	HB-38-16-100	Hex Bolt $\frac{3}{8}$ - 16 x 1	4
5	HW-38	Washer $\frac{3}{8}$	4
6	16-906-27	Trim, Drum Edge	1
7	16-906-21	Drum Center	1
8	16-906-20	Disc 17 $\frac{1}{2}$ , Crank Side	1
9	HWL-516	Lockwasher $\frac{5}{16}$	8
10	HB-516-18-075	Hex Bolt $\frac{5}{16}$ - 18 x $\frac{3}{4}$	8
11	16-129-09	Crank Assembly $\frac{3}{4}$	1
12	16-129-10	Brake Assembly $\frac{3}{4}$	1
13	HNTL-38-16	Nylon Lock Nut $\frac{3}{8}$ - 16	4
14	HNTL-516-18	Nylon Lock Nut $\frac{5}{16}$ - 18	2
15	16-129-03	Lock Pin Assembly	1
16	HB-516-18-075	Hex Bolt $\frac{5}{16}$ - 18 x $\frac{3}{4}$	2
	HW-516	Washer $\frac{5}{16}$	2
17	16-129-07	Frame Assembly	1
18	16-906-08	Mounting Pillow Block (Bottom)	2
19	16-906-24	Bearing	2
20	16-906-07	Mounting Pillow Block (Top)	2
21	16-906-23	Swivel Assembly $\frac{3}{4}$	1
	16-906-30	Seal Kit ( For 16-906-23 )	1



# 14-308 HOSE REEL MOUNT

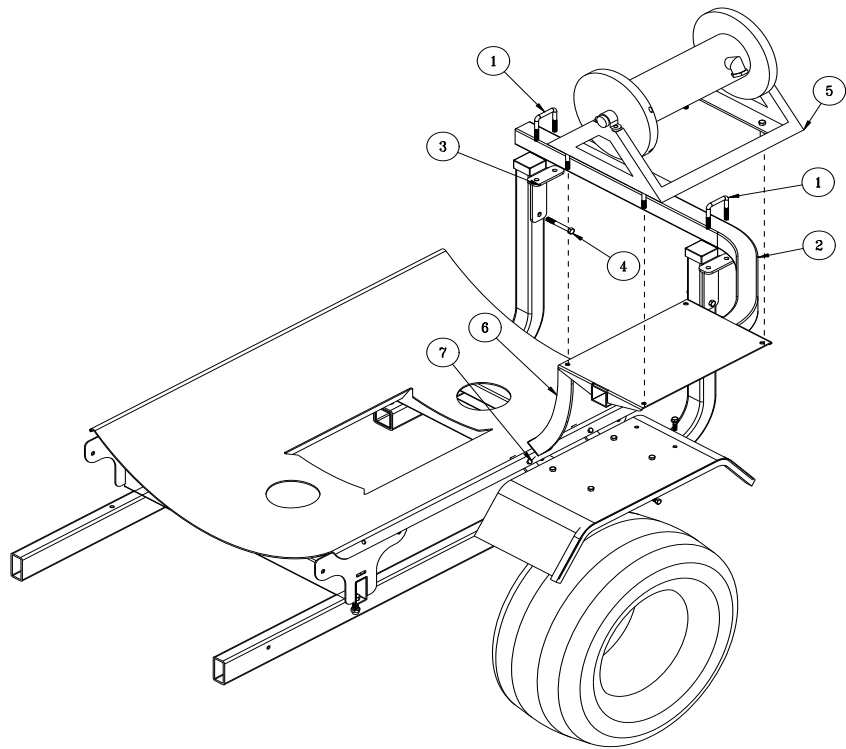

REF#	PART#	DESCRIPTION	QUANTITY
1	17-537	Square U-Hex Bolts	2
2	15-841	Reel Platform	1
3	15-840	Mount Brackets	2
4	HB-38-16-300	Hex Bolt, $\frac{3}{8}$ - 16 x 3	4
	HNTL-38-16	Nylon Lock Nut, $\frac{3}{8}$ - 16	4
	HW-38	Flat Washer, $\frac{3}{8}$	4
5	16-906	Electric Hose Reel	1
	16-129	Manual Hose Reel	1
	18-249	Brass Fitting, $\frac{3}{4}$ MPT x $\frac{3}{4}$ HB	1
6	15-853	Support Bracket	1
7	HB-1420-100	Hex Bolt, $\frac{1}{4}$ -20 x 1	1

1. Wear protective clothing when draining the tank and taking apart the lines.
2. Drain tank and spray system in a safe and approved method insuring that no chemical or water remain in tank as you will be taking apart lines.
3. Remove key from ignition, set park brake and block wheels.
4. Install hose reel mount on the left side of the machine over the rear wheel.
5. Use the clamps and Hex Bolts to secure the mount to the machine.
6. Install the support bracket from the reel platform to the tank carrier using the 1" Hex Bolt.
7. Put hose reel on hose reel bracket with fitting to the rear of machine. Use four Hex Bolts  $\frac{5}{16}$  - 18 x 1" and four  $\frac{5}{16}$  - 18 Nylon Lock Nuts to hold in place. Tighten Hex Bolts.
8. Put 18-249 barb fitting into hose reel.

# 1752 HOSE REEL PLUMBING

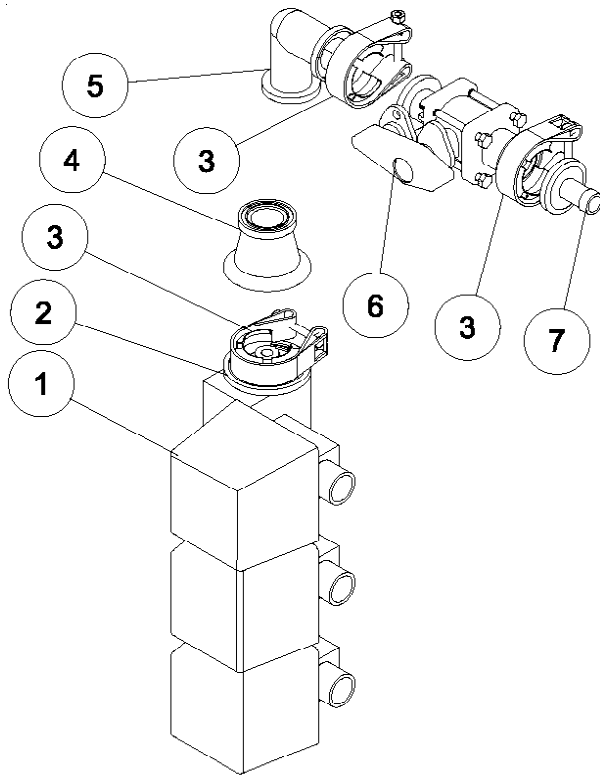

**RAVEN 440**

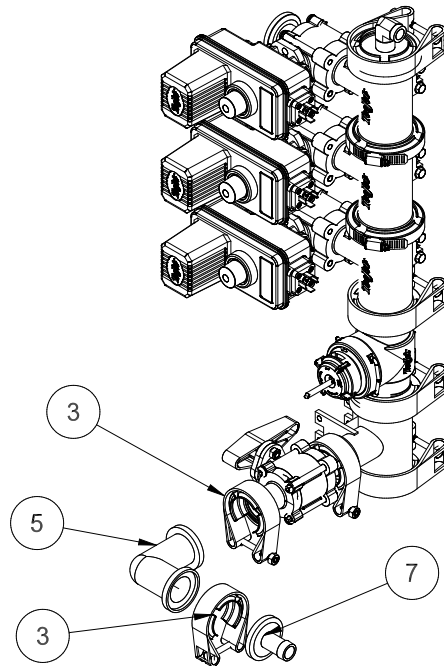

**TEEJET RADION 8140**

REF#	PART#	DESCRIPTION	QUANTITY
1	15-552	Electric Spray Controller	1
2	15-742	Inlet Cover	1
3	15-740	50 Series Clamp	3
4	15-748	Reducer Coupling	1
5	15-736	#50 Elbow Coupling	1
6	15-738	Flanged Ball Valve	1
7	15-749	Hose Barb	1

## INSTALLATION INSTRUCTIONS

1. **RAVEN 440:** On the top of the Electric Spray Control Valve you will find a cover. Remove clamp and cover. Install a 15-748 reducer in place of the cover you just removed. Reinstall clamp and tighten. The cover will not be used again. Install the rest of the fittings as shown.
2. **TeeJet 8140:** Some machines have the ball valve already installed. Remove cover from the tee or the ball valve. Install the rest of the fittings as shown.
3. Route the  $\frac{3}{4}$ " hose from the hose barb to the hose barb on the hose reel and secure with a 18-040 Hose clamp.
4. Secure the hose to the machine with a nylon tie strap.
5. There may be parts left over that you will not need.

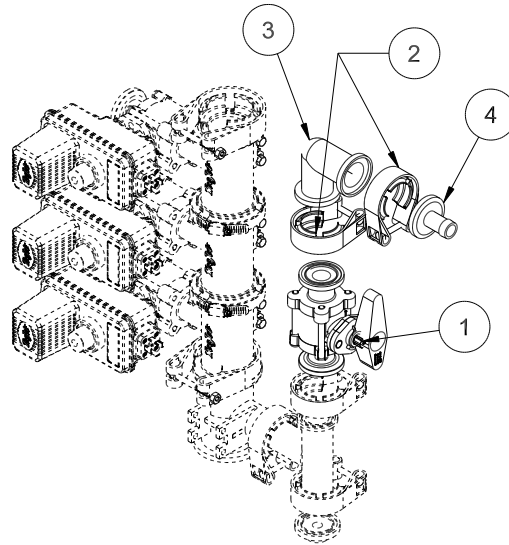

REF#	PART#	DESCRIPTION	QUANTITY
1	15-738	Flanged Ball Valve	1
2	15-740	50 Series Clamp	2
3	15-736	#50 Elbow Coupling	1
4	15-749	Hose Barb	1

## INSTALLATION INSTRUCTIONS

**Some machines are shipped with the flanged ball valve already installed. If your machine has the ball valve on the tee, remove cap from ball valve and skip to step 3.**

1. Between the boom control valves and the fuel tank you will find a tee fitting with a black cap on top of it. Remove the clamp and the cap.
2. Install the 15-738 ball valve (Ref 1) onto the top of the tee using the clamp and o-ring you removed in step 1. The Handle can be positioned so it clears the other hoses by rotating it before the clamp is tightened. Tighten clamp when ball valve is in the position you wanted.
3. Install the 15-736 Elbow (Ref 3) on top of the ball valve pointing to the back of the machine and secure with 15-740 clamp (Ref 2). Tighten.
4. Install the 15-749 flanged hose barb (Ref 4) on to the open end of the elbow with a 15-740 clamp (Ref 2). Tighten.
5. Route the  $\frac{3}{4}$ " hose from the hose barb you just installed to the hose barb on the hose reel. Secure with an 18-40 hose clamp. Secure hose to machine with 22-075 nylon ties.
6. There will be parts left over that you will not need.

# 17-505 FOAM MARKER FOR 1750 DRAWING

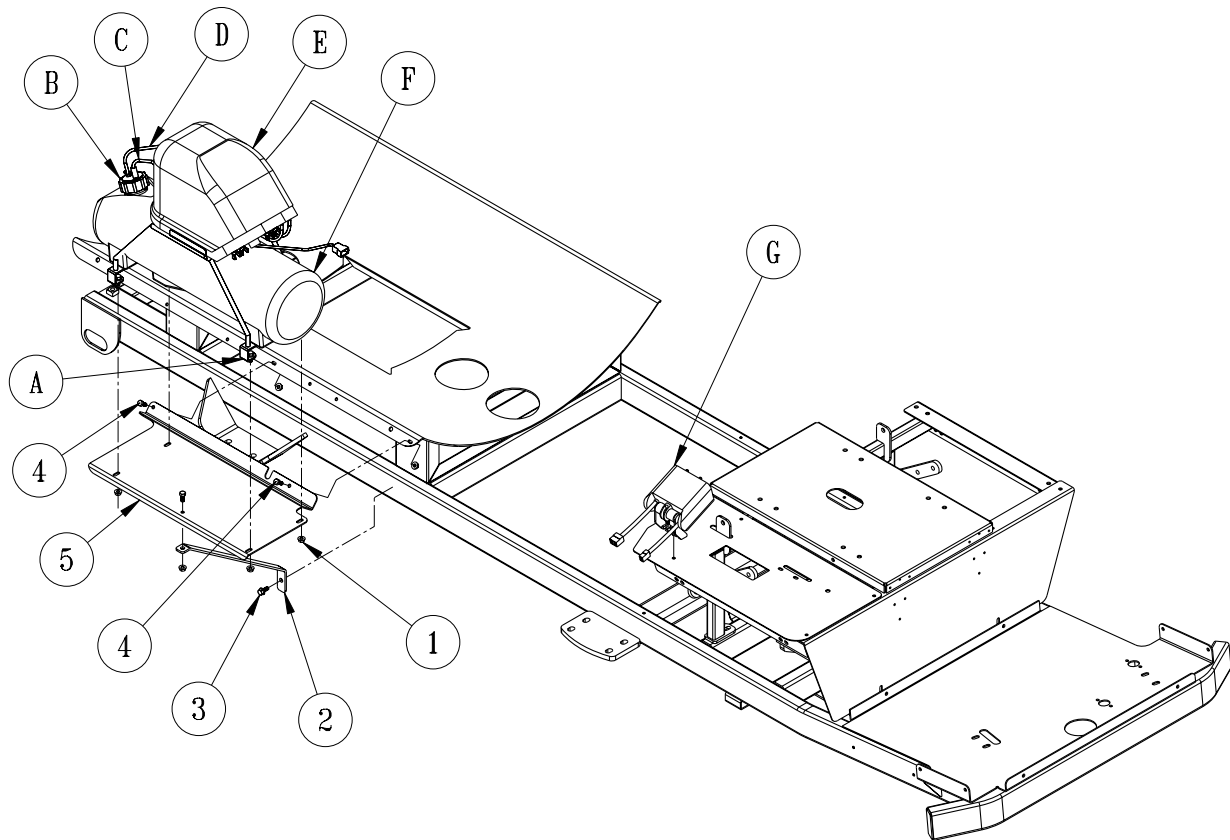

REF#	PART#	DESCRIPTION	QUANTITY
1	HBFL-516-18-075	Flange Hex Bolt, $\frac{5}{16}$ -18 x $\frac{3}{4}$	7
	HNFL-516-18	Flange Whiz-loc Nut, $\frac{5}{16}$ -18	7
2	15-689	Foamer Bottom Brace	1
3	HBFL-516-18-075	Flange Hex Bolt, $\frac{5}{16}$ -18 x $\frac{3}{4}$	1
4	HN-14-20-075	Hex Bolt, $\frac{1}{4}$ -20 x $\frac{3}{4}$	2
	HBFL-14-20	Flange Whiz-loc Nut, $\frac{1}{4}$ -20	2
5	15-755	Mount Plate	1
A	14-291-04	Tank Bracket	2
B	14-284-02	Cap Assembly	1
C		Blue Tube	1
D		Clear Tube	1
E	14-291-03	Compressor Only	1
	14-291-01	Black Cover	1
F	14-291-02	Foamer Tank	1
G	14-291-05	Double Switch Box	1
	33-508	Fuse	1
	15-506-02	Center Switch	1
	14-291-14	Switch	1
A-G	14-291	Foamer (includes parts A-G)	1

# INSTALLATION INSTRUCTIONS

**Safety:** Before working on machine stop engine, set park brake, remove key from ignition and block wheels. Disconnect negative (-) battery terminal.

1. Mount the switch box to the panel to the right of the operator's seat. Remove the drill screw on the right hand rear side and mount the Switch Box (Ref. G) using this screw. The switch box must be mounted facing towards the operator's seat.

## WIRING

Use dielectric grease on all electrical connections. Connect power cable (15-509) to the switch box. Turn the switch off. Route the power wire to the fuse block (on the inside of the engine cover) out of the way of any heat or moving parts. Use nylon ties as needed. Cut the power wire with enough length to connect the fuse block. Put the slide on terminal with heat shrink onto the wire ends and connect to fuse block. Red to positive(+), black to negative(-). Insert 10 amp fuse into slot which has red wire attached to it.

## MOUNTING THE FOAMER UNIT

1. Position the Mount Plate (Ref. 5) as illustrated and mount to the Tank Carrier using two  $\frac{1}{4}$ -20 x  $\frac{3}{4}$  Flange Hex Bolts and  $\frac{1}{4}$ -20 Flange Whiz-loc Nuts. Leave loose.
2. Connect Brace (Ref. 2) to the Mount Plate using one  $\frac{5}{16}$ -18 x  $\frac{3}{4}$  Flange Hex Bolt and  $\frac{5}{16}$ -18 Flange Whiz-loc Nut. Tighten. Hex Bolt Brace (Ref. 2) to the tapped hole in the mainframe using one  $\frac{5}{16}$ -18 x  $\frac{3}{4}$  Flange Hex Bolt. Tighten.
3. Tighten hardware connecting Mount Plate (Ref. 5) to the Tank Carrier.
4. Place Foamer unit (Refs. A-G) on the Mount Plate (Ref. 5) and Hex Bolt in place with four  $\frac{5}{16}$ -18 x  $\frac{3}{4}$  Flange Hex Bolts and  $\frac{5}{16}$ -18 Flange Whiz-loc Nuts (Ref. 1). Foamer must be placed with the Cap Assembly (Ref. B) facing to the **rear** of the machine.
5. Tighten hardware.

## CONNECTING THE CAP ASSEMBLY

Connect the blue tube to the tank cap connector which is also connected to the large blue tube which hangs below the cap. This is the soap outlet tube. Connect the clear tube to the other connector on the tank cap. This is the air input tube. Tighten connectors hand tight, assembly tank cap onto tank.

## HOSES

Being careful not to cut the tubing, cut the oversleeve back approximately 2" (5 cm) to expose blue and clear tubing. Remove blue wing nut from top connector of foam nozzle and slide it on the blue tube with the threads facing toward end of tube. Slide blue tube all the way over the top of the small tube on foam nozzle. Slide wing nut back to the threads and hand tighten. Follow the same steps for the clear tube and tube nut.

Route the tubing along underside of main frame using tie downs as necessary.

Install opposite ends of air-liquid tubes to compressor, again cutting back the oversleeve approximately 2" (5 cm) and inserting blue and clear tubes for the left boom section into the tubing connectors on the right side of compressor as far as possible. Follow the same steps for the right boom tubing. Notice the right boom is inserted into left side of compressor. To release tubing from compressor, hold black ring around tubing, and pull tube out.

# FOAMER NOZZLE MOUNT

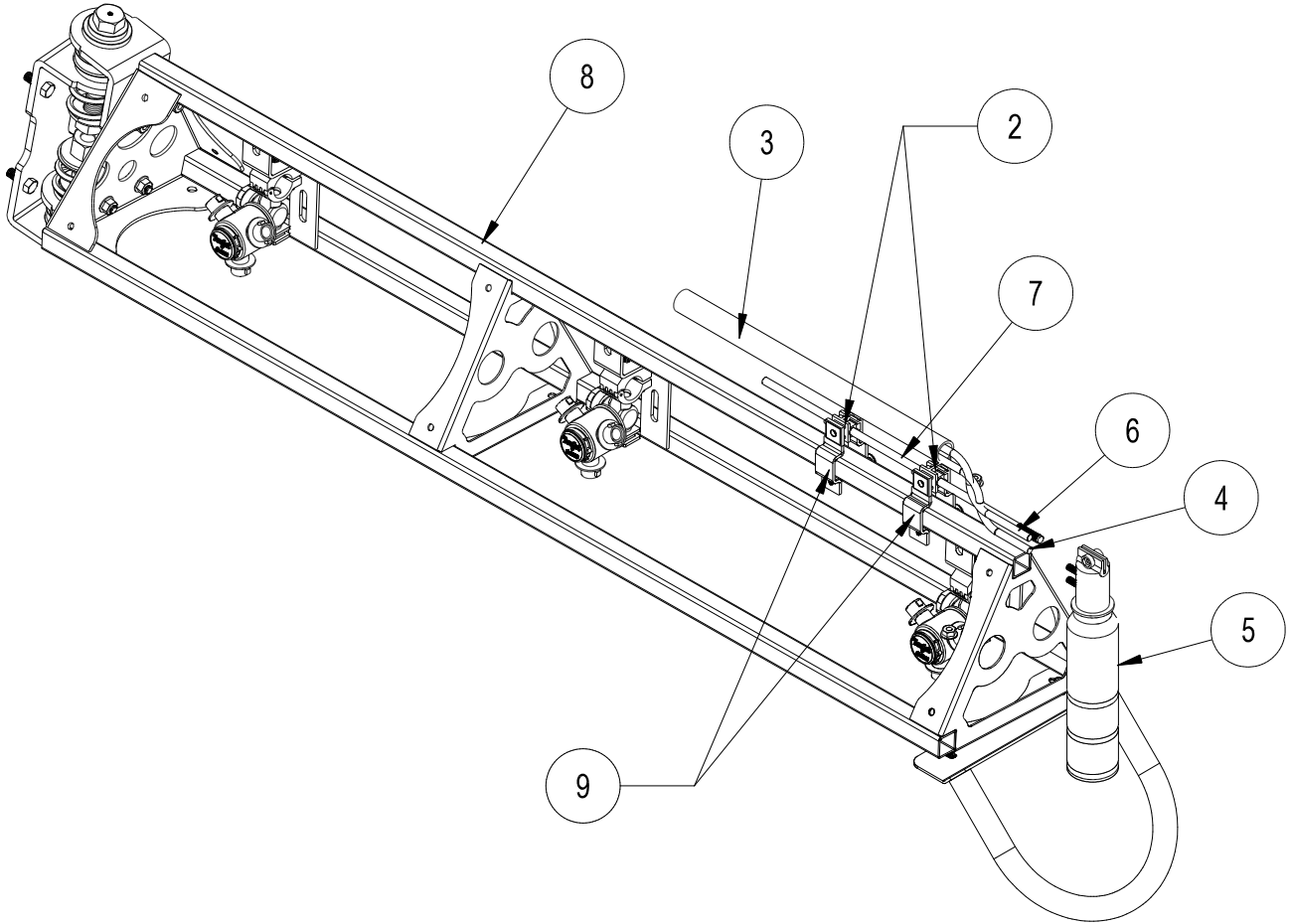

Accessories

REF#	PART#	DESCRIPTION	QUANTITY
2	16-987	Foam Nozzle Mounting Kit	1 per boom
3	15-507	Foamer Tubing	1
4		Clear Tubing	
5	15-511	Foam Nozzle	2
6		Blue Tubing	
7	15-510-01	Nozzle Mounting Rod	2
8		Boom	
9	16-795	Square Clamp	4

## INSTRUCTIONS

1. Slide hose clamp onto drop tube of foam nozzle and attach restrictor bell.
2. Place splined end of Nozzle mounting rod (Ref 7) into top of foam nozzle (Ref 5). Tighten screw.
3. Slide two foam nozzle mounts (Ref 2) onto the rod. Place square clamps (Ref 9) on foam nozzle mounts and mount the square clamps to the boom (Ref 8). Adjust foam nozzle mounts and clamps so nozzle assembly will clear end of boom. Tighten foam nozzle mounts and square clamps to prevent side to side movement. Do the same to the other side.
4. Being careful not to cut the tubing (Ref 3), cut the oversleeve back approximately 2" (5 cm) to expose blue (Ref 6) and clear tubing (Ref 4).
5. Remove blue wing nut from top connector of foam nozzle and slide it on the blue tube with the threads facing toward end of tube. Slide blue tube all the way over the top of the small tube on foam nozzle. Slide wing nut back to the threads and hand tighten. Follow the same steps for the clear tube and tube nut.
6. Route the tubing along underside of main frame using tie downs as necessary.
7. Install opposite ends of air-liquid tubes to compressor, again cutting back the oversleeve approximately 2" (5 cm) and inserting blue and clear tubes for the left boom section into the tubing connectors (Ref A) on the right side of compressor as far as possible.
8. Follow the same steps for the right boom tubing. Notice the right boom is inserted into left side of compressor. To release tubing from compressor, hold black ring around tubing, and pull tube out.
9. Hose's must be routed on bottom of the boom square tubing.
10. Install hose guard using 2 drill screws (you may want to drill a  $\frac{3}{16}$  pilot hole first).
11. Place another hose guard against first and install in same manner.
12. Repeat process for other boom side.
13. Connect small plastic electrical plug under compressor to electrical extension cable.
14. Cut cable and strip casing, allowing enough length to connect to fuse block.
15. Strip and connect slide on connectors to each wire and use the heat shrink.
16. Connect black negative (-) wire to the ground and connect red wire to the positive (+).
17. Insert 10 amp fuse into slot which red wire was attached to.

# 14-291 FOAMER REPLACEMENT PARTS

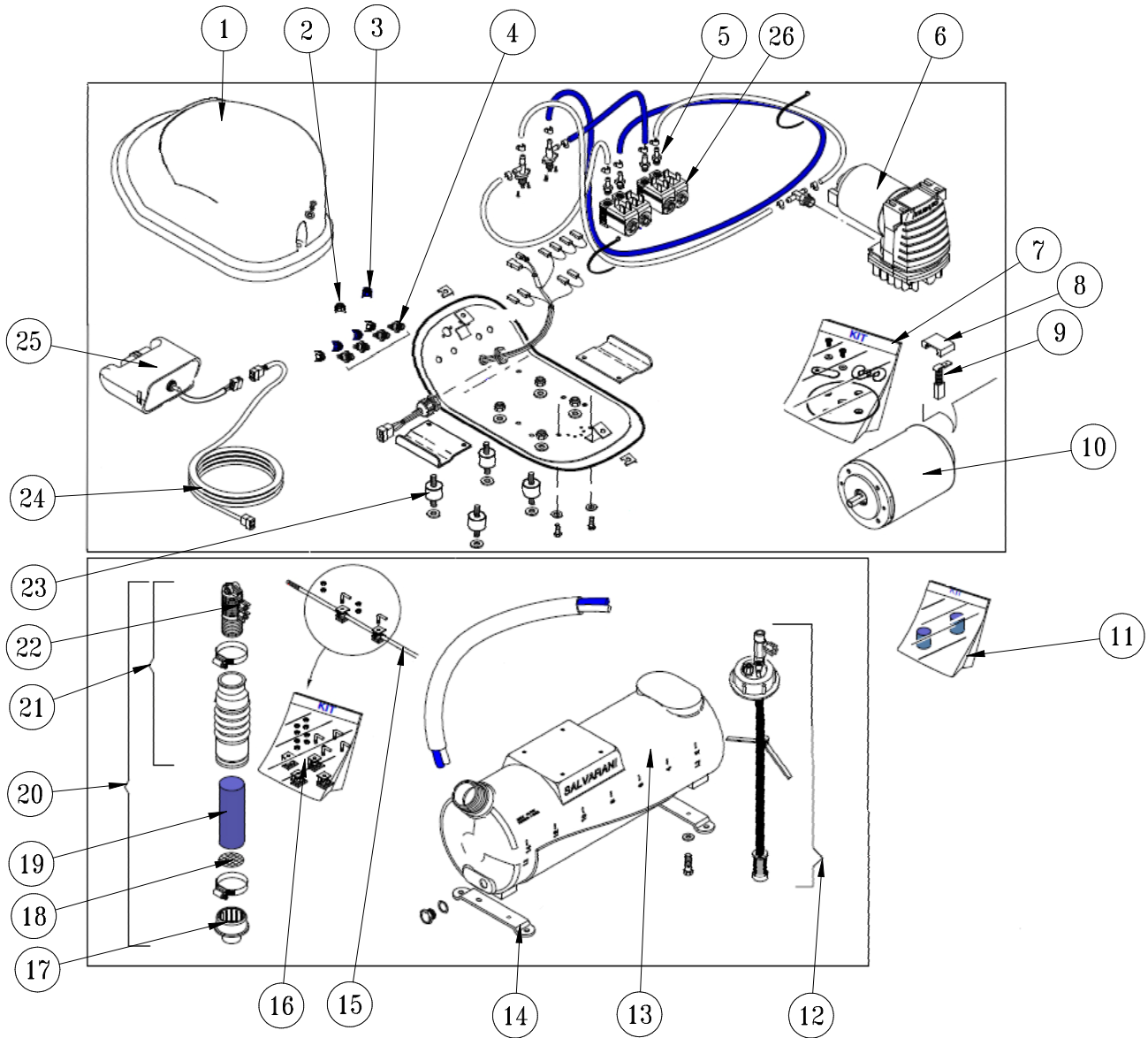

Accessories



## 14-291 FOAMER REPLACEMENT PARTS

REF#	PART#	DESCRIPTION	QUANTITY
1	14-291-01	Black Cover	1
2	14-291-08	White Fly Nut	1
3	14-291-09	Blue Fly Nut	1
4	14-284-10	Tubing Connector	1
5	14-291-17	M6 Tubing Connector	1
6	14-536	Compressor Complete	1
7	14-291-11	Diaphragm Replacement Kit	1
8	15-505-08	Brush Retainer	1
9	15-505-06	Brush	1
10	15-505-07	12V Electric Motor	1
11	15-511-02	Foam Sponge	1
12	14-284-02	Cap Assembly	1
13	14-291-02	Foamer Tank	1
14	14-291-04	Tank Brackets	2
15	15-510-01	Nozzle Mounting Rod	2
16	16-987	Foam Nozzle Mounting Kit	1
17	14-284-09	Foam Nozzle Reducer	2
18	15-511-09	Stainless Steel Screen	2
19	15-511-08	Long Foam Sponge	2
20	15-511	Foam Nozzle	2
21	15-511-07	Foam Nozzle Assembly	1
22	15-511-01	Foam Nozzle Sub Assembly	1
23	14-291-15	Shock Absorber	4
24	14-284-05	Extension Wire	1
25	14-291-05	Switch Box	1
	15-506-02	Switch	1
26	14-284-11	Solenoid Valve	4

# FOAM MARKER WIRING

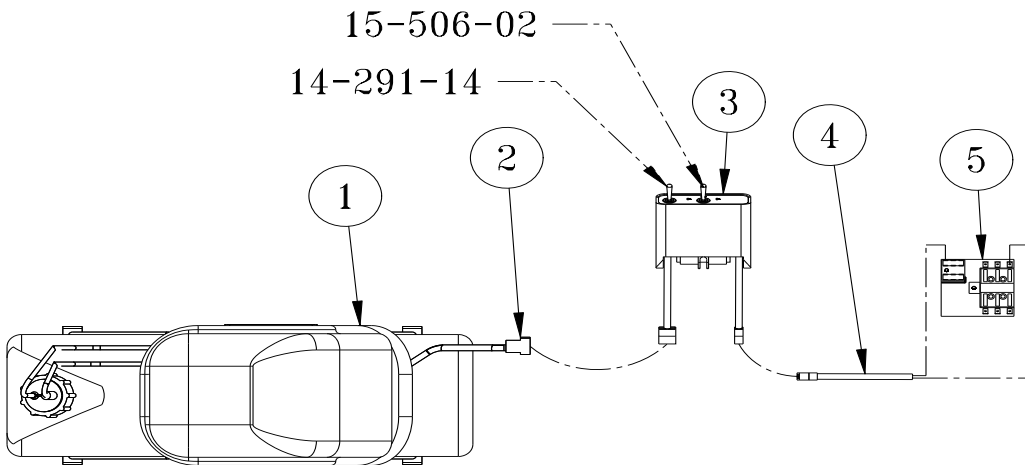

REF#	PART#	DESCRIPTION	QUANTITY
1	14-291-03	Compressor	1
2	15-504-04	Wiring Harness	1
3	14-291-05	Switch Box	1
	33-508	Fuse	1
	15-506-02	Center Switch	1
	14-291-14	Switch	1
4	15-509	Power Cable	1
5	33-271	Fuse Block (part of machine)	1
	33-508	Fuse 15 amp	1

Accessories

# 10-653 FRESH WATER WASH TANK - FRONT MOUNT

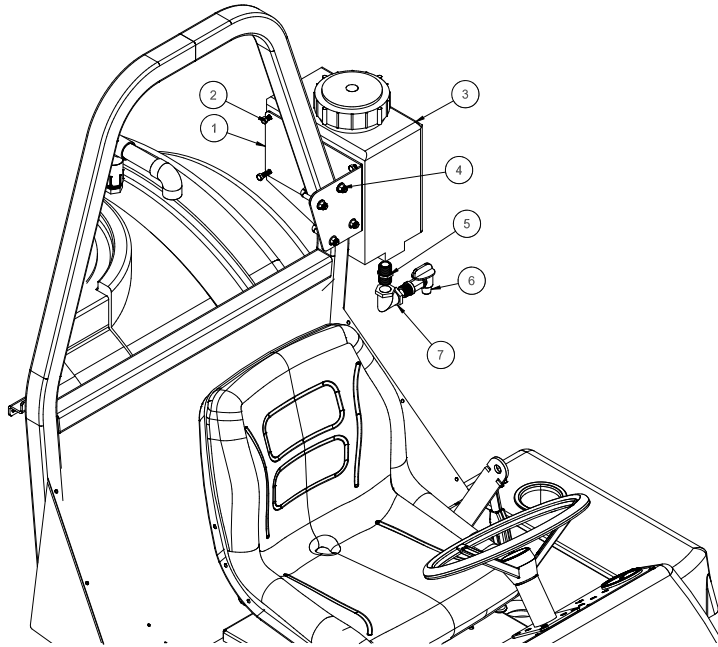

REF#	PART#	DESCRIPTION	QUANTITY
1	10-652	Mount Plate	1
2	HB-516-18-075	Bolt $\frac{5}{16}$ - 18 x $\frac{3}{4}$	4
	HWL-516	Lockwasher $\frac{5}{16}$	4
	HW-516	Washer $\frac{5}{16}$	4
3	10-234	Wash Tank	1
4	17-537	Square U-Bolt	2
5	16-158	Close Nipple	1
6	16-151	Elbow	1
7	16-960	Spigot	1

1. Fresh Water Wash Tank mounts on the left side ROPs.
2. Mount the wash tank (Ref 3) onto the mount bracket (Ref 1) using four  $\frac{5}{16}$  x  $\frac{3}{4}$  bolts, washers and lockwashers (Ref 2). Tighten.
3. Install the nipple (Ref 5), elbow (Ref 6) and spigot (Ref 7) into the bottom of wash tank (Ref 1). Use thread tape on all threads.
4. Mount the tank assembly to the left side ROPs with u-bolts (Ref 4). Tighten.
5. Rinse tank with clear water and check for leaks around fittings.



**WARNING**

**This tank is for fresh clear water ONLY. Do not put chemicals in this tank.**

# 30-006 FRESH WATER TANK - REAR MOUNT

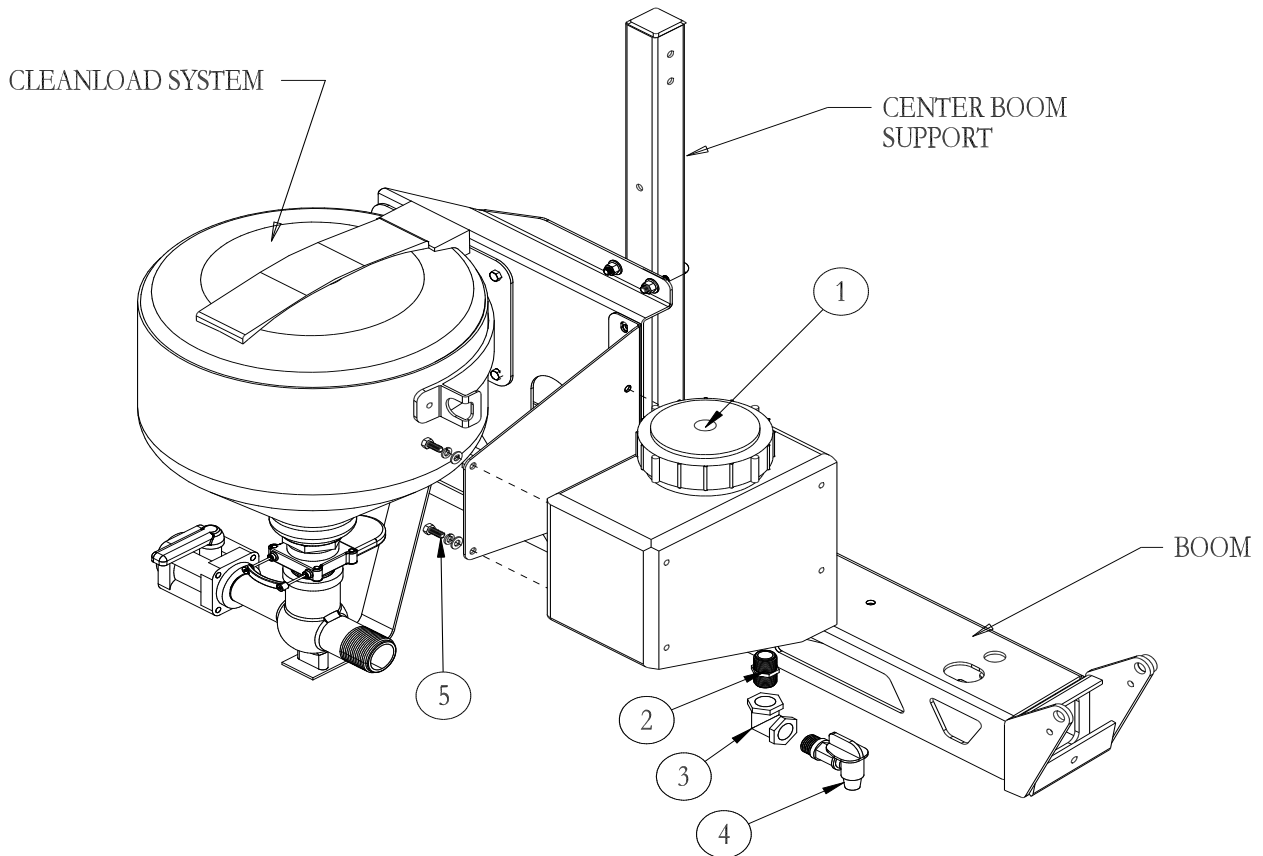

REF#	PART#	DESCRIPTION	QUANTITY
1	10-234	Wash Tank	1
	10-234-01	Lid	
2	16-158	Close Nipple	1
3	16-151	Elbow	1
4	16-960	Spigot	1
5	HB-516-18-075	Hex Bolt, $\frac{5}{16}$ - 18 x $\frac{3}{4}$	4
	HWL-516	Lock Washer, $\frac{5}{16}$	4
	HW-516	Washer, $\frac{5}{16}$	4

1. Fresh Water Wash Tank mounts on the rear of all the machines.
2. The Bracket is already attached to the Super Boom center boom post.
3. Install the nipple (Ref 2), elbow (Ref 3) and spigot (Ref 4) into the bottom of wash tank (Ref 1). Use thread tape on all threads.
4. Mount the tank onto the mount bracket using four  $\frac{5}{16}$  x  $\frac{3}{4}$  Hex Bolts, washers and lockwashers. Tighten.
5. Rinse tank with clear water and check for leaks around fittings.

**⚠ WARNING**

**This tank is for fresh clear water ONLY. Do not put chemicals in this tank.**

## 14-515 WATER METER KIT (GALLONS)

## 15-618 WATER METER KIT (LITERS)

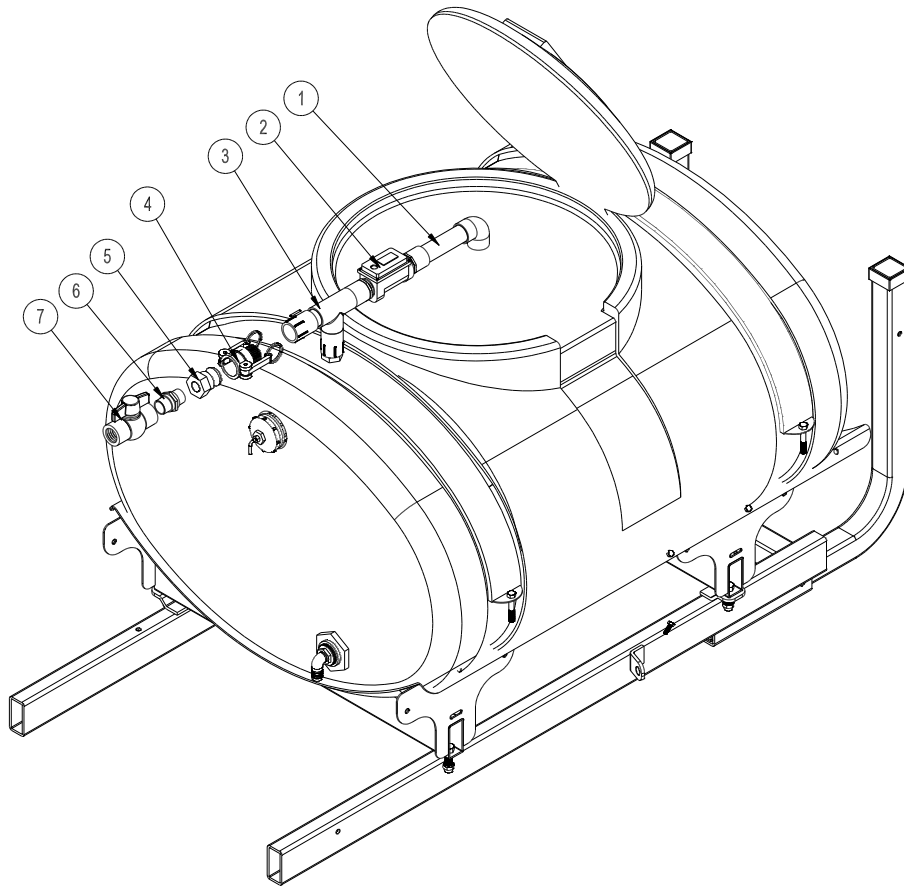

REF #	PART #	DESCRIPTION	QUANTITY
1	14-524	Filler Outlet	1
2	14-514	Water Meter (Gallons)	1
	14-527	Water Meter (Liters)	1
3	14-525	Filler Inlet	1
4	16-962	1" Quick Coupler (already on machine)	1
5	16-961	1" Adapter Quick Coupler (already on machine)	1
6	16-851	1" Nipple (already on machine)	1
7	18-448	1" Ball Valve (already on machine)	1

1. Thoroughly flush the service line upstream of the meter to remove dirt and debris.
2. The DLJ Meter is for use **only** with **COLD WATER** up to 122°F (50°C)
3. Slowly open any upstream valves to prevent damage to the meter.

### Gallons to Cubic feet Conversion :

Multiply gallons reading by 0.1337 to get cubic feet.

There are 7.48052 gallon per cubic foot.

# 15-619 CHEMICAL CLEAN-LOAD SAFE FILL SYSTEM

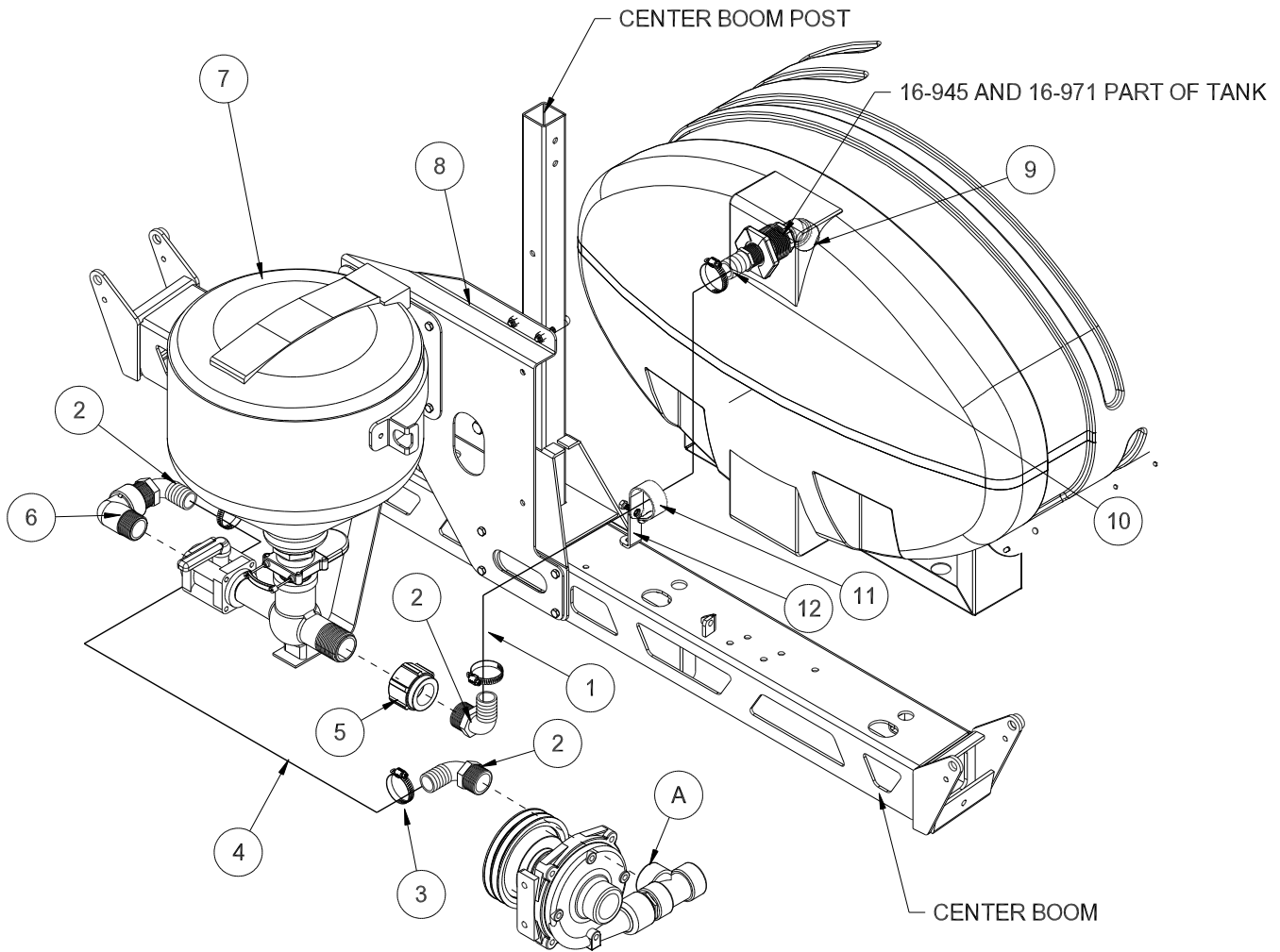

REF#	PART #	DESCRIPTION	QUANTITY
1	8897-31	1 1/4" Discharge Hose x 31"	1
2	16-156	90° Hose Barb	3
3	18-116	Hose Clamp	4
4	8897113	1 1/4" Discharge Hose x 113"	1
5	18-391	Coupling	1
6	16-972	Street Elbow	1
7	15-620	Clean-load Assembly	1
	HBFL-516-18-075	Flange Hex Bolt, <sup>5</sup> / <sub>16</sub> - 18 x <sup>3</sup> / <sub>4</sub>	4
	HNFL-516-18	Flange Whiz-loc Nut, <sup>5</sup> / <sub>16</sub> - 18	4
8	17-635	Clean Load Mount (comes with boom)	1
9	16-975	45° Elbow	1
10	16-159	Fitting	1
11	HLC-A-200	Loom Clamp	1
12	14-604	Loom Clamp Mount	1
	HB-516-18-100	Hex Bolt, <sup>5</sup> / <sub>16</sub> - 18 x 1	2
	HNFL-516-18	Flange Whiz-loc Nut, <sup>5</sup> / <sub>16</sub> - 18	2

# 15-619 CHEMICAL CLEAN-LOAD INSTALLATION INSTRUCTIONS

1. Make sure sprayer tank is empty and flush all chemical residue from sprayer. Always wear protective clothing, goggles and gloves.
2. Remove plug from tee on spray pump (Ref A).
3. Install one of the 90° fittings (Ref 2), should point to the back of the machine.
4. Install 88" of 1 1/4" discharge hose (Ref 4) onto the elbow on the pump that points back and tighten hose clamp (Ref 3).
5. Route the 88" hose to the back of the sprayer so it connects over the top of the left boom support tube.
6. Mixer Mount (Ref 8) is already installed on boom center post.
7. Mount Clean-load Assembly (Ref 5) onto mixer mount using  $5/16 \times 3/4$  flange Hex Bolts and flange nuts. Tighten.
8. Install 18-391 reducer coupling (Ref 4) onto outlet side. Then a 16-156 90° elbow (Ref 2) into the coupling pointing up and one into valve with yellow handle. Tighten fittings so that the elbow in the valve is pointing up and forward. The outlet fitting should be pointing up.
9. Remove the plug from the top back of the spray tank and install 16-972 45° fitting (Ref 9) and 16-159 hose barb (Ref 10) and tighten.
10. Install the loom clamp mount (Ref 12) and the loom clamp (Ref 11) onto the center boom, using the  $5/16 \times 1$  Hex Bolt and Nylon Lock Nut.
11. Now the 31" hose (Ref 1) can be installed from the tank to the outlet fitting through the loom clamp. Tighten with hose clamps.
12. The hose from the spray pump can be connected to the inlet fitting and tightened with hose clamps.
13. Make sure all hardware, fittings and clamps are tight. Add about 25 gallons of water to the spray tank. Start sprayer and circulate water through system to check for leaks.
14. Be sure to read start up, loading and shutdown instructions for Clean-load Assembly before using with chemicals. When working with chemicals **Always** wear protective clothing, goggles and gloves.

## TROUBLE SHOOTING

Symptom	Corrective Action
Low education rate	Check pump pressure and flow. Cleanload Eductor performance is based on flow and pressure to the system. Note requirements for high education rates.  Increase outlet hose size back to tank.
Plugged or clogged bottle rinse nozzle	Disassemble rotary portion of nozzle from lower valve assembly and back flush until nozzle ports are clear of debris.
Plugged or clogged tank rinse nozzle	Disassemble rotary portion of nozzle from NPT hose barb and back flush until nozzle ports are clear of debris. Remove screen and flush with water to clear away foreign material.
Fitting leaks	Check for cracks in fitting. Replace fitting if necessary.  Disassemble and add more joint seal in compound if leak occurs on threads.

# 15-620 CHEMICAL CLEAN-LOAD® PARTS DRAWING

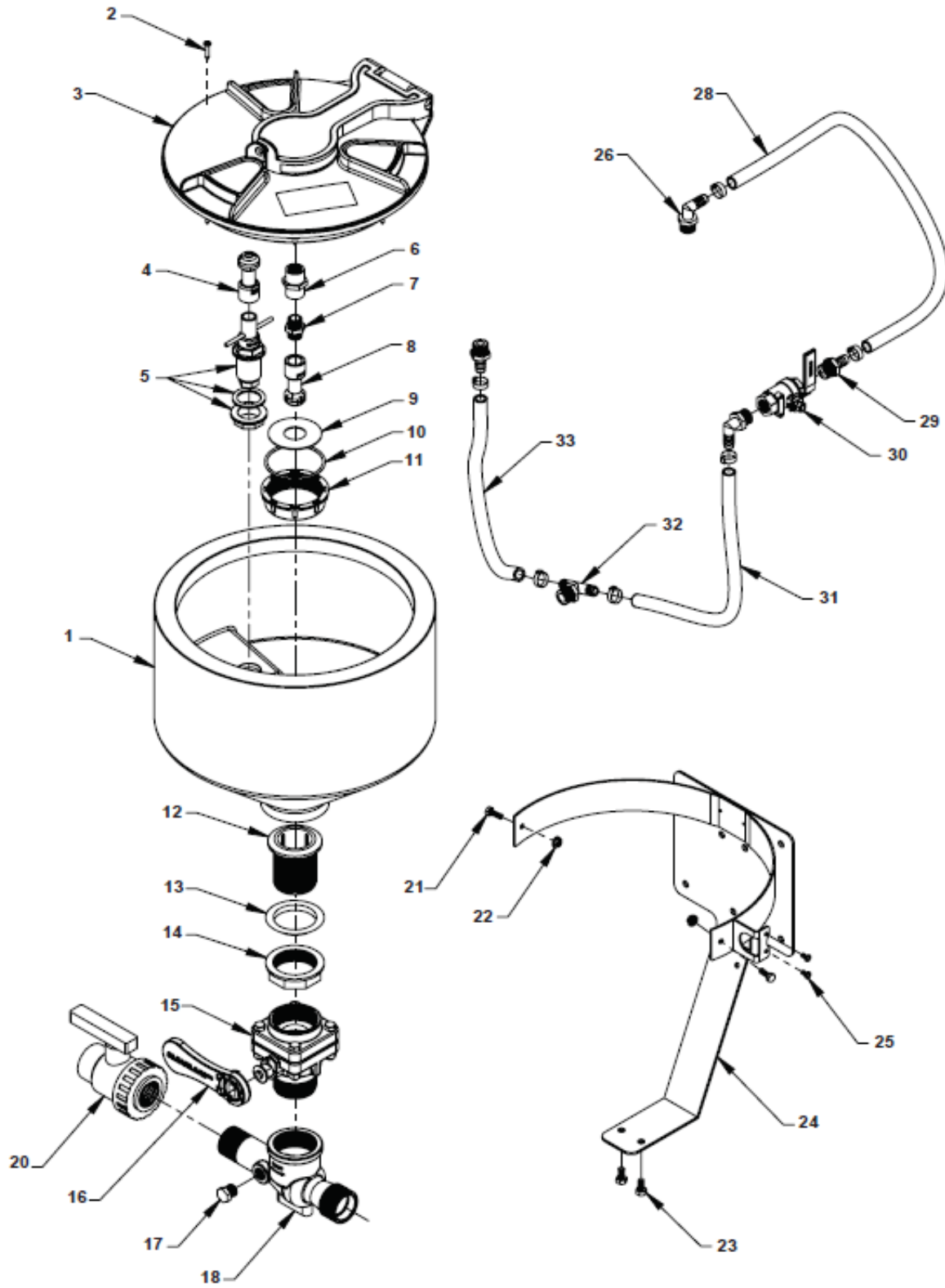

Accessories



## 15-620 CHEMICAL CLEAN-LOAD® PARTS LIST

REF#	PART#	DESCRIPTION	QUANTITY
1	15-620-21	Tank	1
2		Screw, #6 x 1"	8
3	15-620-02	Tank Lid	1
4	15-620-22	ProClean Container Nozzle	1
5	15-620-23	ProClean Push Valve Assembly	1
	15-620-19	Tank Rinse	1
	15-620-20	Gasket, 1"	1
6		1/2 x 1/2 FNPT Coupler	1
7		1/2 x 1/2 Thread Nipple	1
8		ProClean Tank Wash Nozzle	1
9		Splash Retainer	1
10		O-ring Breather	1
11		Nut, Breather	1
12	15-620-18	Drain Head, 2"	1
13	15-620-17	Gasket 2", Tapered	1
14	15-620-16	Locking Ring, 2"	1
15	15-620-12	Ball Valve	1
	15-620-15	Gasket 2" BSP	1
16	15-620-13	Handle, Clean-load	1
17		1/2 MNPT PP Hex Plug	1
18	15-620-04	Clean-load Eductor	1
20	15-620-14	Ball Valve, 1 1/4 Single Union	1
21		Screw	2
22		Flange Nut	2
23		Hex Head Screw	2
24	15-620-01	Frame, Back Mount	1
25		Phillips Head Screw	2
26	15-620-11	Elbow 1/2"	2
28	15-620-08	Hose, Tank Rinse, 1/2" EPDM	1
29	15-620-09	HB, 1/2 MNPT x 1/2 HB	2
30	15-620-10	Valve, SS Tank Rinse	1
31	15-620-06	Hose, Valve Feeder, 1/2" EPDM	1
32	15-620-05	HB Tee, 1/2 MNPT to 1/2 HB	1
33	15-620-07	Hose, Bottle Rinse, 1/2" EPDM	1

# OPERATING INSTRUCTION

## STARTUP

1. All Clean-load valves must be closed prior to starting: inlet ball valve, knife valve and hopper rinse ball valve.
2. Open lid to check for foreign objects which may hinder performance or contaminate the system.
3. Close and lock lid by turning cover clockwise.
4. Divert pump flow to Clean-load inlet line. A pressure of 30 PSI minimum and 150 PSI maximum must be used. Highest pressures increase eduction rate and available wand suction.
5. Turn inlet ball valve on (yellow handle).
6. Open knife valve, located on the bottom of hopper, by pushing handle in (red handle).
7. Unlock and open lid slowly by turning cover counterclockwise.

## LOADING LIQUID OR POWDERED CHEMICAL INTO HOPPER

8. Pour required amount of chemical into hopper. Avoid splashing liquids or powdered chemicals outside of hopper.
9. Rinse empty chemical containers if applicable. Place container opening over container rinse valve and press down. This will activate the rinse valve and rinse container.
10. Rinse Clean-load hopper. Close and lock lid by turning cover clockwise. Release the safety locking band on the hopper rinse ball valve and turn on for 20 seconds. Close ball valve and return locking band to locked position.
11. Open lid and inspect for chemical residue. Repeat step 10 as necessary.
12. Close knife valve by pulling red handle out towards you. Turn inlet (yellow handle) off.

## LOADING LIQUID AND/OR POWDERED CHEMICAL WITH SUCTION LANCE

**Note: Lance suction is dependent upon eductor pressure and flow. For best results, use highest pressure available up to 150 PSI maximum.**

8. Insert lance body with o-ring into eductor until the o-ring is sealed.
9. Use the free end of the lance to pierce bag or container to vacuum powdered or liquid chemical.
10. Rinse lance. Place lance end into a clean container of water to rinse lance assembly.
11. Remove lance body from eductor and drain any remaining fluid into hopper.
12. Close knife valve (red handle). Turn inlet valve (yellow handle) off.

## SHUTDOWN

1. Ensure that:
  - All valves are closed. Be sure to close knife valve first. (Close by pulling red handle out towards you.)
  - Chemical residue has been cleaned.
  - Hopper lid is closed and locked by turning cover clockwise.
2. Divert pump flow back to normal operation.

## DECAL LIST

This is a list of decals located on the Spray Star 1750. Part number, description and location will help in reordering decals.

B	15-902	Decal, Tank Volume 1750
C	15-903	Decal, Rear Tank Volume
D	15-463	Decal, Spray Pump
E	15-636	Decal, Spray Star 1750
F	15-637	Decal, Control Panel
G	15-672	Decal, Dash
H	15-719	Decal, Speed Control
I	16-228	Decal, Towing
J	25-279	Decal, Hot and Moving Parts
K	25-307	Decal, Gas
L	25-286	Decal, Pinch Point
M	25-298	Decal, Warning Hot
N	25-356	Decal, Tire Pressure
O	25-373	Decal, Smithco
P	25-381	Decal, 96 dBA
Q	27-077	Decal, Smithco
R	27-093	Decal, Hydraulic Oil
S	25-277	Decal, Battery
T	34-147	Decal, Smithco
U	14-803	Decal, Clean Agitator Line Strainer

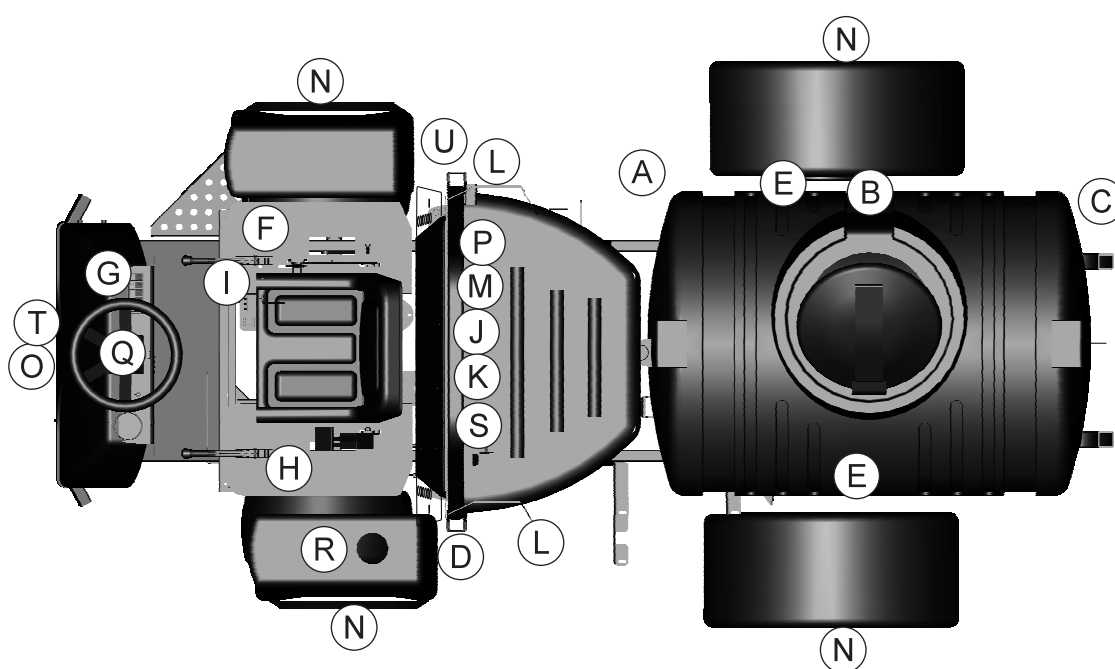

# QUICK REFERENCE REPLACEMENT PARTS

## REPLACEMENT FILTERS

23-031	Hydraulic Oil Filter	
76-487	Engine Oil Filter	Briggs # 842921
76-395-01	Air Cleaner Cartridge	Briggs # 841497
76-395-02	Safety Filter Cartridge	Briggs # 821136
13-488	Key Switch	
76-310	Key Set	
50-403	Fuel Filter	

## REPLACEMENT BELTS

15-704	Spray Pump Belt
--------	-----------------

## SEAL KITS

15-301	Power Steering Orbital Motor
15-301-01	Seal Kit
15-839	Hydraulic Cylinder
14-531	Seal Kit
76-238	Wheel Motors
14-080	Seal Kit
76-398	Hydrostatic Pump
77-239-22	Seal Kit
76-197	Gear Pump
76-197-08	Seal Kit

## FLUIDS

Engine Oil	SAE 10W-40 API Service SJ or higher Motor Oil
Hydraulic Fluid	SAE 10W-40 API Service SJ or higher Motor Oil

## OTHER PARTS

16-953	Hinged Cover On Tank with Gasket	
16-953-01	Gasket For Cover	
16-169	Strainer Basket	
15-818	#75 Fitting Oring	
15-817	#50 Fitting Oring	
	Spark Plugs	Champion type RC12YC (Gap 0.040 inch (1.02mm))

# The Smithco Commercial Products Two-Year Limited Warranty

Smithco, Inc. (Smithco) warrants your 2016 or newer Smithco Commercial Product ("Product") purchased after October 1, 2016 to be free from defects in materials or workmanship for the period of time listed below. Where a warrantable condition exists, Smithco will repair the Product at no cost to you including diagnosis, labor (at the Smithco standard labor rate, subject to the Smithco flat rate schedule), and parts.

## Warranty Duration is:

- (1) Two years, 1500 operational hours\* from the date of delivery to the original purchaser or Five years from the date of original manufacturer of the product, whichever occurs first. (\*Products equipped with hour meter).
- (2) Products used in rental situations are covered for 90 days from date of delivery to original user/renter.

## Owner Responsibilities:

As the Product owner, you are responsible for required maintenance and adjustments stated in your Owner's Manual. Failure to perform required maintenance and adjustments can be grounds for disallowing a warranty claim. **You are particularly responsible to train all present and future operators of this product on the safe operation of this product at your location.**

## Instructions for Obtaining Warranty Service:

You are responsible for notifying the Authorized Smithco Products Distributor from whom you purchased the Product as soon as you believe a warrantable condition exists and not later than 30 days from discovery of the condition.

If you need help locating an Authorized Smithco Distributor, or if you have questions regarding your warranty rights or responsibilities, you may contact us at:

Smithco Product Support Department  
200 West Poplar Ave.  
Cameron, Wisconsin 54822  
Telephone: 800-891-9435 E-Mail: [ProductSupport@Smithco.com](mailto:ProductSupport@Smithco.com)

## Maintenance Parts:

Parts scheduled for replacement as required maintenance ("Maintenance Parts"), are warranted for the period of time up to the scheduled replacement time for that part.

## Items/Conditions Not Covered:

Not all product failures or malfunctions that occur during the warranty period are defects in materials or workmanship. The items/conditions listed below are not covered by this warranty:



Product failures which result from the use of non-Smithco replacement parts, or from installation and use of add-on, modified, or unapproved accessories are not covered.



Product failures which result from failure to perform required maintenance and/or adjustments are not covered.



Product failures that result from operating the Product in an abusive, negligent or reckless manner are not covered.



This warranty does not apply to parts subject to consumption through use, unless found to be defective. Examples of parts which are consumed, or used up, during normal Product operation include, but are not limited to: blades, tines, teeth, scarifiers, rakes, plates, wear plates, castor wheels, tires, batteries, filters, belts, nozzles, etc.



This warranty does not apply to failures caused by outside influence. Items considered to be outside influence include, but are not limited to, weather, storage practices, contamination, use of unapproved coolants, lubricants, additives, or chemicals, etc.



This warranty does not apply to normal "wear and tear" items. Normal "Wear and Tear" includes, but is not limited to, damage to seats due to wear or abrasion, worn painted surfaces, scratched decals or windows, etc.



Smithco may require the return of failed parts or components in order to determine the validity of any warranty claim.



Smithco will not be obligated to replace components of other manufacturers if inspection by the original component manufacturer indicates that failure was due to normal wear and tear, expected consumption through use or improper care or service.

#### **Other Legal Disclaimers:**

The above remedy for product defects through repair or replacement by an authorized Smithco distributor or dealer is the purchaser's sole remedy for any defect. This warranty gives you specific legal rights, and you may also have other rights which vary from state to state.

**THERE ARE NO OTHER EXPRESS WARRANTIES OTHER THAN THOSE SET FORTH ABOVE. ALL IMPLIED WARRANTIES OF MERCHANTABILITY AND FITNESS FOR USE ARE LIMITED TO THE DURATION OF THE LIMITED WARRANTIES CONTAINED HEREIN.**

Some states may not allow limitations on how long an implied warranty lasts, so the above limitation may not apply to you.

**THE SMITHCO COMPANY IS NOT LIABLE FOR INDIRECT, INCIDENTAL OR CONSEQUENTIAL DAMAGES IN CONNECTION WITH THE USE OF THE PRODUCT, INCLUDING ANY COST OR EXPENSE OF PROVIDING A SUBSTITUTE PRODUCT OR SERVICE DURING PERIODS OF MALFUNCTION OR NON-USE.**

Some states may not allow the exclusion of indirect, incidental or consequential damages, so the above exclusion may not apply to you.

**Smithco neither assumes, nor authorizes any person to assume for it, any other liability in connection with the sale or use of this product.**

