

Parts & Service



Spray Star 3180
Model 30-000-B
SN: 300G091

July 2011

Product Support:

Hwy 55 & Poplar Ave; Cameron WI 54822
1-800-891-9435 productsupport@smithco.com

CONTENTS

Introduction

Introduction.....	1-3
Introduction.....	1
General Safe Practices.....	2
Specifications	3
Optional Spray Equipment.....	3

Service

Service.....	4-11
Maintenance.....	4-6
Wheel Creep.....	6
Adjustments.....	7
Service Chart.....	8
End User's Service Chart.....	9
Storage.....	10-11

Diagrams

Diagrams	12-15
Wiring Diagram.....	12-13
Hydraulic Diagram.....	14-15

Parts

Parts.....	16-49
Body & Frame	16-17
Nose Cone	18-21
Linkage.....	22-23
Front Axle	24-25
Oil Tank and Fuel Tank	26-27
Seat Panel.....	28-29
Engine and Pumps	30-33
Cooler and Exhaust.....	34-35
Spray Tank.....	36-37
Turbo Quad Agitator	38-39
15-301 Orbitor	40-41
16-998 Hypro® Pump	42-43
30-102 Hydrostatic Pump.....	44-47
30-101 Eaton Motor.....	48-49

Accessories

Reference

Accessories	50-100
Plumbing 3182 System (Raven 440)	50-51
Plumbing 3184 System (Raven 203).....	52-53
Plumbing 3185/3186 (Envizio Pro II/SharpShooter).....	54-55
Plumbing 3187/3188 (Raven 440/SharpShooter)	56-59
Controls 3182 System (Raven 440)	60-61
Controls 3184 System (Raven 203).....	62-63
Controls 3185/3186 (Envizio Pro II/SharpShooter)	64-65
Controls 3187/3188 (Raven 440/SharpShooter).....	66-67
16-524 Motorized Control Valve	68
15-737 Strainer.....	69
15-743 Manifold Ball valve	70-71
17-580 20' Heavy Duty Boom.....	72-73
17-525 18' Heavy Duty Boom.....	74-75
Triple Nozzle Assembly	76
Sharp Shooter Nozzles.....	77
30-010 Electric Hose Reel	78-80
30-009 Hose Reel	81
Hose Reel Installation.....	82-83
Hose Reel Adjustments	83
30-004 Foam Marker Installation.....	84-90
15-511 Foam Nozzle Sub Assembly	92
14-515 Water Meter Kit (Gallons).....	93
15-618 Water Meter Kit (Liters)	93
30-006 Fresh Water Tank	94-95
30-007 Chemical Cleanload System	96-97
15-620 Chemical Cleanload® Eductor	98-99
15-835 Tank Rinsing System.....	100
Reference	101-102
Decal List.....	101
Quick Reference Replacement Parts	102
Warranty	

Thank you for purchasing a **Smithco** product.

Read this manual and all other manuals pertaining to the Spray Star 3180 carefully as they have safety, operating, assembly and maintenance instructions. Failure to do so could result in personal injury or equipment damage.

Keep manuals in a safe place after operator and maintenance personnel have read them. Right and left sides are from the operator's seat, facing forward.

All **Smithco** machines have a Serial Number and Model Number. Both numbers are needed when ordering parts. The serial number plate on the Spray Star 3180 is located on the left main frame, by front bumper. Refer to engine manual for placement of engine serial number.

For easy access record your Serial and Model numbers here.

SMITHCO		DATE OF MFG.
WAYNE, PENNSYLVANIA 19087 USA 610-688-4009 Fax 610-688-6069		<input type="text"/>
SERIAL NO.	kW/hp	
<input type="text"/>	<input type="text"/>	
MODEL NO.	kg/lb	
<input type="text"/>	<input type="text"/>	



Information needed when ordering replacement parts:

1. Model Number of machine
2. Serial Number of machine
3. Name and Part Number of part
4. Quantity of parts



SAFE PRACTICES

1. It is your responsibility to read this manual and all publications associated with this machine.
2. Never allow anyone to operate or service the machine or its optional equipment without proper training and instructions. Never allow minors to operate any equipment.
3. Learn the proper use of the machine, the location and purpose of all the controls and gauges before you operate the equipment. Working with unfamiliar equipment can lead to accidents.
4. Wear all the necessary protective clothing and personal safety devices to protect your head, eyes, ears, hands and feet. Operate the machine only in daylight or in good artificial light.
5. Inspect the area where the equipment will be used. Pick up all debris you can find before operating. Beware of overhead obstructions and underground obstacles. Stay alert for hidden hazards.
6. Never operate equipment that is not in perfect working order or without decals, guards, shields, or other protective devices in place.
7. Never disconnect or bypass any switch.
8. Carbon monoxide in the exhaust fumes can be fatal when inhaled, never operate a machine without proper ventilation.
9. Fuel is highly flammable, handle with care.
10. Keep engine clean. Allow the engine to cool before storing and always remove the ignition key.
11. Disengage all drives and set park brake before starting the engine.
12. Never use your hands to search for oil leaks. Hydraulic fluid under pressure can penetrate the skin and cause serious injury.
13. This machine demands your attention. To prevent loss of control or tipping of the vehicle:
 - A. Use extra caution in backing up the vehicle. Ensure area is clear.
 - B. Do not stop or start suddenly on any slope.
 - C. Reduce speed on slopes and in sharp turns. Use caution when changing directions on slopes.
 - D. Stay alert for holes in the terrain and other hidden hazards.
14. Before leaving operator's position:
 - A. Disengage all drives.
 - B. Set park brake.
 - C. Shut engine off and remove the ignition key.
 - D. If engine has to run to perform any maintenance keep hands, feet, clothing and all other parts of body away from moving parts.
15. Keep hands, feet and clothing away from moving parts. Wait for all movement to stop before you clean, adjust or service the machine.
16. Keep the area of operation clear of all bystanders.
17. Stop engine before making repairs/adjustments or checking/adding oil to the crankcase.
18. Use parts and materials supplied by **Smithco** only. Do not modify any function or part.
19. Use caution when booms are down as they extend out beyond the center line of the machine.
20. The tank is a confined space, take precaution.

These machines are intended for professional maintenance on golf courses, sports turf, and any other area maintained turf and related trails, paths and lots. No guaranty as to the suitability for any task is expressed or implied.



SPECIFICATIONS SPRAY STAR 3180

WEIGHTS AND DIMENSIONS

Length	128" (325 cm)
Width	72" (183 cm)
Height w/ ROPS	84" (213 cm)
Height w/ Booms Folded	136" (345 cm)
Wheel Base	68" (173 cm)
Weight Empty	2340 lbs (1061 kg)
Weight Full	4950 lbs (2245 kg)

SOUND LEVEL (DBA)

At ear level	88.4 dBA
At 30 ft. (9.14 m)	77 dBA

ENGINE

Make	Kubota
Model#	V1505
Code / Spec#	1G994-0000
Horsepower	35.5 hp (26.6 kW)
Fuel (EMISSIONS)	No.1-D or No. 2-D, S500: Low Sulfur Diesel (LSD) less than 500 ppm or 0.05 wt. % No1-D or No.2-D, S15: Ultra Low Sulfur Diesel (ULSD) less than 15 ppm or 0.0015 wt. %
Cooling System	Liquid Cooled
Lubrication System	Full Pressure
Alternator	40 Amp

WHEELS & TIRE

Front:	Two 20 x 11.00 x 10 Turf; 20 psi (1.4 bar)
Rear:	Two 29 x 14.00 x 15 Multi-Trac; 30 psi (2.0 bar)

SPEED

Infinitely Variable	0-10 m.p.h. (0-18 kph)
---------------------	------------------------

BATTERY

	Automotive type 24F - 12 volt
BCI Group	Size 24
Cold Cranking Amps	900 minimum
Ground Terminal Polarity	Negative (-)
Maximum Length	10.25" (26 cm)
Maximum Width	6.88" (17 cm)
Maximum Height	10" (25 cm)

FLUID CAPACITY

Crankcase Oil	See Engine Manual
Fuel	7 gallon (26.5 liters)
Hydraulic Fluid	10 gallon (37.8 liters)
Radiator	1.06 gallons (4 liters)
Grade of Hydraulic Fluid	SAE 10W-40 API Service SJ or higher Motor Oil

OPTIONAL EQUIPMENT

15-618	Water Meter Kit	30-009	Manual Hose Reel
17-525	18' HD Electric lift Boom	30-010	Electric Hose Reel
17-580	20' HD Elec/Hyd Boom	30-004	Foam Marker
30-006	Clear water Wash Tank	15-835	Tank Rinse System
30-007	Chemical Cleanload Safe Fill		



MAINTENANCE



CAUTION

Before servicing or making adjustments to machine, stop engine and remove key from ignition.

NOTE:

Use all procedures and parts prescribed by the manufacturer's. Read the engine manual before operation.

LUBRICATION

Use No. 2 General purpose lithium base grease and lubricate every 100 hours. The Spray Star 3180 has 7 grease fittings.

- A. One on the rod end of hydraulic cylinder.
- B. One on each the right and left spindles.
- C. One on the center front pivot.
- D. One on the idler arm.
- E. One on each of the pedal relays.

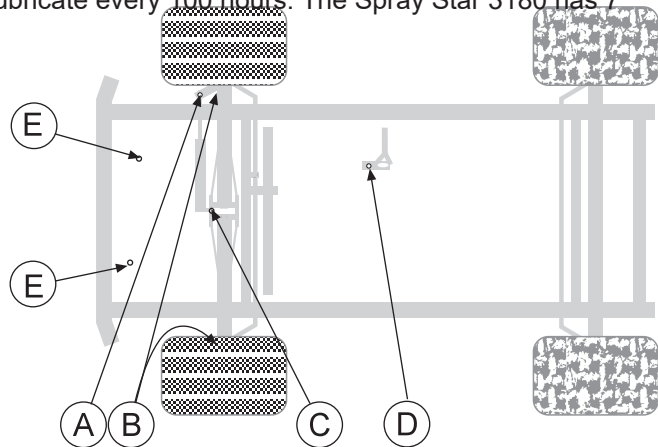

ELECTRICAL CONNECTIONS

Use dielectric grease on all electrical connections.

AIR CLEANER ON ENGINE

Since the air cleaner on this engine is a dry type, never apply oil to it.

1. Open evacuator valve (see engine manual) once a week to remove large particles of dust and dirt.
2. Wipe the inside of the air cleaner with a cloth if it gets wet or dirty.
3. Avoid touching the element except when cleaning.
4. When dust adheres to the element, gently tap element on flat surface.
5. When carbon or oil adheres to the element clean according to engine manual.
6. Replace the element every year or every 6 months.
7. IMPORTANT - Make sure wing bolt for the element is tight enough. If it is loose, dust and dirt may be sucked in, wearing down the cylinder liner and piston ring, resulting in poor power output.

NOTE:

Do not use petroleum solvents, e.g., kerosene, which will cause cartridge to deteriorate. Do not use pressurized air to clean cartridge. Pressurized air can damage cartridge.

FUEL

CHECK EMISSION REGULATIONS OF YOUR AREA

With Emission control now in effect diesel fuel specification type and sulfur content % (ppm) used must be in compliant with all applicable emission regulations for the area in which the engine is operated.

Use of diesel fuel with sulfur content less than 0.10% (1000 ppm) is strongly recommended.

If high sulfur fuel is used, change oil and oil filters twice as often.

DO NOT USE Fuels that have sulfur content greater than 1.0% (10000 ppm).

Diesel fuels specified in EN 590 or ASTM D975 are recommended.

Since KUBOTA diesel engines of less than 56kW (75 hp) utilize EPA Tire 4 and Interim Tier 4 Standards, the use of low sulfur fuel or ultra low sulfur fuel is mandatory for these engines, when operated in US EPA regulated areas. Therefore, use No.2-D S500 or S15 diesel fuel as a alternative toe No. 2-D for ambient temperatures below -10°C (14° F).

ENGINE OIL

With strict emission control regulations now in effect, the CF-4 and CG-4 engine oils have been developed for use with low sulfur fuels, for On-Highway vehicle engines. When Non-Road engines run on high sulfur fuel, it is advisable to use a "CF or better" classification engine oil with Total Base Number (a minimum TBN of 10 is recommended).

Check the engine oil before starting or more than 5 minutes after stopping the engine. If oil level is low, remove oil filler plug and add new oil to the prescribed level. Do not overfill. Engine oil should be MIL-L2104C or have properties of API Classifications CD grades or higher. Change the type of Engine oil according to the ambient temperature.

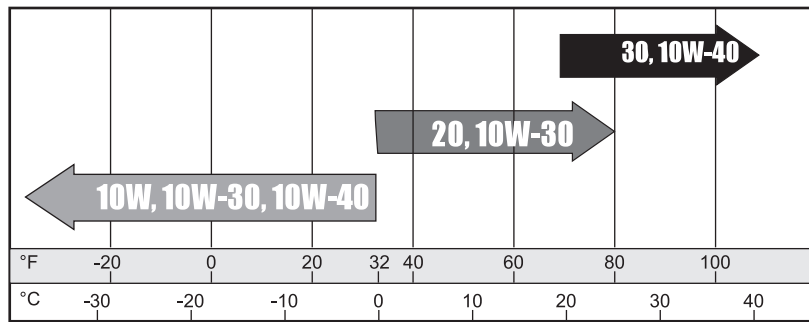

Starting Temperature Range Anticipated Before Next Oil Change

HYDRAULIC OIL

1. Use SAE 10W-40 API Service SJ or higher motor oil.
2. For proper warranty, change oil every 500 hours or annually, which ever is first.
3. Oil level should be 2-2½" (5-6.4cm) from top of the tank when fluid is cold. Do not overfill.
4. After changing oil, run the machine for a few minutes. Check oil level and for leaks.
5. Always use extreme caution when filling hydraulic oil tank or checking level to keep system free of contaminants. Check and service more frequently when operating in extremely cold, hot or dusty conditions.
6. If the natural color of the fluid has become black or smells burnt, it is possible that an overheating problem exists.
7. If fluid becomes milky, water contamination may be a problem.
8. If either of the above conditions happen, change oil immediately after fluid is cool and find the cause. Take fluid level readings when the system is cold.
9. In extreme temperatures you can use straight weight oil. We recommend SAE 30W API Service SG when hot (above 90°F (33°C)) and SAE 10W API Service SJ or higher when cold (below 32°F (0°C) ambient temperature. Use either motor oil or hydraulic oil, but do not mix.
10. Oil being added to the system must be the same as what is already in the tank. Mark the tank fill area as to which type you put in.

TIRE PRESSURE

Caution must be used when inflating a low tire to recommended pressure. Over inflating can cause tires to explode. Front tires should be 20 psi (1.4bar) and rear tires should be 30 psi (2.0bar). Improper inflation will reduce tire life considerably.

MAINTENANCE

BATTERY

Batteries normally produce explosive gases which can cause personal injury. Do not allow flames, sparks or any ignited object to come near the battery. When charging or working near battery, always shield your eyes and always provide proper ventilation.

Battery cable should be disconnected before using "Fast Charge".

Charge battery at 15 amps for 10 minutes or 7 amps for 30 minutes. Do not exceed the recommended charging rate. If electrolyte starts boiling over, decrease charging.

Always remove grounded (-) battery clamp first and replace it last. Avoid hazards by:

1. Filling batteries in well-ventilated areas.
2. Wear eye protection and rubber gloves.
3. Avoid breathing fumes when electrolyte is added.
4.  Avoid spilling or dripping electrolyte.

WARNING Battery Electrolyte is an acidic solution and should be handled with care. If electrolyte is splashed on any part of your body, flush all contact areas immediately with liberal amounts of water. Get medical attention immediately.

Use of booster battery and jumper cables. Particular care should be used when connecting a booster battery. Use proper polarity in order to prevent sparks.

TO JUMP START (NEGATIVE GROUNDED BATTERY):

1. Shield eyes.
2. Connect ends of one cable to positive (+) terminals of each battery, first (A) then (B).
3. Connect one end of other cable to negative (-) terminal of "good" battery (C).
4. Connect other end of cable (D) to engine block on unit being started (NOT to negative (-) terminal of battery)

To prevent damage to other electrical components on unit being started, make certain that engine is at idle speed before disconnecting jumper cables.

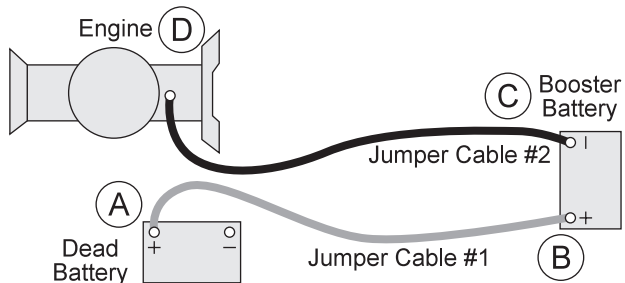

WHEEL CREEP

WHEEL CREEP

"Creep" is when the engine is running and hydrostatic transmission is in neutral, but due to inadequate alignment, wheels still move. Do the following procedure to stop this motion.

1. Lift up and support machine so rear wheels are off the ground and can turn freely.
2. In the engine compartment, the hydrostatic pump is on the right side. The shift arm (D) is on top of the pump. The idler arm (B) has a bearing that rides in the vee of the shift arm. Loosen bolt (A).
3. With engine running, move bearing (B) so it centers on the shift arm (D) and 'wheel creep' stops.
4. Tighten all fasteners and test by using foot pedal linkage to see that 'creep' is removed.
5. Turn engine off and lower machine.

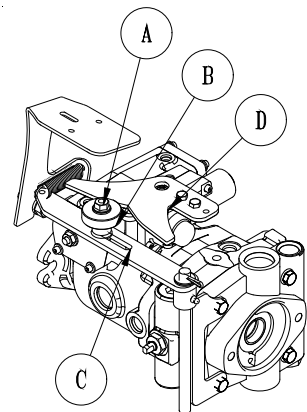

SPRAY PUMP WITH BELT

Located to the right of the engine. The belt should have approximately $\frac{1}{2}$ " (13mm) of deflection in the center of the top strand.

SAFETY INTERLOCK SWITCH

To adjust the interlock switch on the back hydrostatic pump loosen the set screw on the front half of the switch, with the ignition switch OFF. With a continuity tester connected across the switch, it should light with the shift arm centered. Move the shift arm to the right or left and the light should go off. By turning the back half of the switch clockwise it will reduce the amount of travel on the shift arm that is required for the light to remain on. The light must be on **ONLY** with the shift arm centered.

MASTER BOOM SWITCH (FOOT SWITCH)

The master boom switch, located on the left floorboard is used to override the master switch on the computer console of the spray systems. By pushing down it will turn on/off the booms. *For the 440 System* the Master Switch on the computer **must be off** for the master boom control switch to work.

GROUND SPEED CONTROL (FOOT SWITCH)

The ground speed control does not work the same as an automotive type cruise. The ground speed control is located on the center floorboard and is used to lock forward speed.

TO ENGAGE:

1. Flip rocker switch 'On' (green light).
2. Obtain desired speed with foot pedal.
3. Step on foot switch to lock speed.
4. Push foot switch again to disengage.

SPEED CALIBRATION NUMBERS

The speed calibration numbers for the Spray Star 3182 is 612.

SPRAY BOSS CONTROL

Engages and disengages speed boss. Forward is engage and all the way back is disengage. When the lever is engaged it sets a stop for the accelerator. The accelerator pedal must be used to maintain this speed. To adjust speed use the knob on the end of the lever, counter clockwise increases speed and clockwise decreases speed. Disengage the lever and you will have full accelerator pedal range.

TOWING

When it is necessary to move the Spray Star 3180 without the engine running, there are 2 things that need to be done. First, the bypass valve built into hydrostatic pump must be "open" by turning it $\frac{1}{4}$ turn to open. The valve is located on the back side of the pump. An "open" valve allows fluid to pass through the wheels freely. When normal driven operation is desired, valve should be "closed" by turning it clockwise. Failure to "close" the valve with engine running means no power to wheels. Secondly, the hand brake needs to be manually released. The hand brake is located under the engine. To manually release the brake you must loosen the locknut and screw in the stem to the bottom. Tighten the lock nut and pump handle until hard.

MANUAL BRAKE HAND PUMP MANIFOLD

The hand brake is located under the engine. The hand brake is connected to the seat switch and automatically engages when operator gets up from the seat. So when machine is not being driven, the machine is locked down. If engine is not running or you are towing the machine you will have to manually release the brake. **To manually release the brake** you must loosen the locknut and screw in the stem to the bottom. Tighten the lock nut and pump handle until hard.

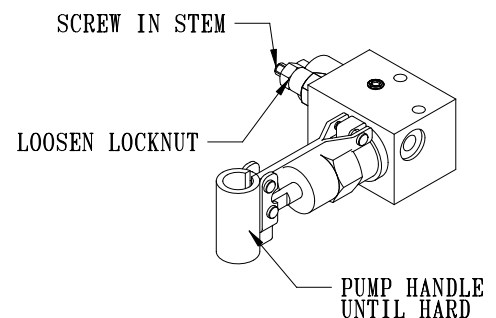

Run machine at half-throttle minimum, prior to operating traction pedal. This will ensure proper brake release.



SERVICE CHART



CAUTION Before servicing or making adjustments to the machine, stop engine, block wheels and remove key from ignition.



Follow all procedures and **ONLY** use parts prescribed by the manufacturer. Read the engine manual before maintenance.

The suggested maintenance checklist is not offered as a replacement for the manufacturer's engine manual but as a supplement. You must adhere to the guidelines established by the manufacturer for warranty coverage. In adverse conditions such as dirt, mud or extreme temperatures, maintenance should be more frequent.

Maintenance Service Interval	Maintenance Procedure
After the first 50 operating hours	Torque the wheel lug nuts. (84-94 ft/lb (23.5-100 Nm)) Change the engine oil and filter.
After the first 20 operating hours	Replace hydraulic filter
Before each use daily	Check the engine oil. Check the hydraulic fluid level. Check the tire pressure. Check condition of hydraulic hoses and fittings. Inspect and clean the machine. Inspect cooling system.
Every 100 hours	Check the battery fluid level and cable Change hydraulic filter Check engine for leaks or loose parts. Check air cleaner. Check the pressure (20 psi for it (30 psi for e a)). Torque the wheel lug nuts. (84-94 ft/lb (23.5-100 Nm)) Grease Machine. Check Planetary for oil Check belts is for (where needed)
Every 200 Hours	Check radiator hoses. Change the engine oil and filter. Change oil filter Change hydraulic filter Clean battery terminals
Every 400 hours	Replace Fuel Filter
Every 500 hours or yearly	Lubricate machine Replace Planetary Oil (80/90 Gear Lube) Visual inspection of machine and hydraulic hoses Change oil Torque lug nuts. Check battery terminals and electrolyte level Change all filters.



END USER SERVICE CHART

Duplicate this page for routine use

Maintenance Check Item	For the Year of:						
	Year	2018	2019	2020	2021	2022	2023
Check the Safety Seal Switch							
Check starting operation							
Check maintenance							
Check the engine oil level							
Check the condition of the air filter							
Clean the engine cooling fins							
Check for unusual engine noises							
Check the hydraulic oil level							
Check hydraulic hoses and fittings for damage							
Check for fluid leaks							
Check the tire pressure (cold) (200 kPa)							
Check the instrumentation							
Inspect the rear suspension for squeaking							
Check neutral oil							
Change oil filter							
Change oil							
Lubricate Machine							
Secure all warning devices and labels							

Service



STORAGE

NOTE:

To prevent damage from freezing, pour window washer fluid into spray systems tank and operate pump to circulate mix through gun and hose back to tank. Open boom control to circulate through rest of spray system.

1. Clean the exterior surfaces of the engine.
2. Change the oil and filter while the engine is still warm from operation.
3. Drain coolant from the radiator. Open cock at the bottom of the radiator, and remove the pressure cap to drain water completely. Leave the cock open. Hang a not written "No Water" on the pressure cap. Since water freezes when temperature drops below 0°C (32° F) it is important that no water is left in the machine.
4. Remove battery from the engine, adjust the electrolyte level, and recharge it. Store battery in a dry dark place.
5. Store machine in a clean, dry place.

XTENDED STORAGE

1. Check for any damaged parts or missing decals. Replace as needed.
2. Drain crankcase completely and refill with recommended engine oil or equivalent.
3. Lubricate all grease points.
4. Check coolant protection and level.
5. Clean exterior surface of engine.
6. Seal all openings in engine and accessories with non-hygroscopic material. Mask off all areas to be used for electrical contact.
7. Tape all openings and make sure all surfaces are dry. Then spray all taped openings, all engine accessories including ignition wiring, and all exterior surfaces of engine with Insulation Compound.
8. Disconnect, remove and clean battery. Check electrolyte level. Charge the battery and store in a cool dry place (NOT directly on cement).
9. Put blocks or stands under the machine to take weight off tires.

AFTER STORAGE

1. Check for any damaged parts or missing decals. Replace as needed.
2. Lubricate all grease points.
3. Clean exterior surface of engine.
4. Remove all tape and obstructions from exterior engine surfaces.
5. Charge and replace battery.
6. Check tire pressure.
7. Remove blocks or supports from under the machine.
8. Check engine oil level and coolant level and lubricate all grease points.
9. Fill fuel tank.
10. Check belt tension.
11. Run engine approximately 5 minutes before putting the engine under load.

E

WIRING DIAGRAM

REF#	PART#	DESCRIPTION	QUANTITY
1	77-223	Timer	1
	30-042-06	Relay	1
2	50-359	Warning Light	3
3	10-556	Speedometer	1
4	12-017	Hour Meter	1
5	14-292	Seat Switch	1
6	13-488	Ignition Switch	1
7	32-014	Lights	2
8	15-725	Mount Panel End	1
	15-727	Switch Actuator	1
	15-782	Rocker Switch, Unlit	1
9	15-729	Mount Panel Middle	1
	15-726	Switch Body, Light	1
	15-732	Actuator, Green	1
10	15-729	Mount Panel Middle	1
	15-726	Switch Body, Light	1
	15-731	Actuator, Amber	1
11	15-729	Mount Panel Middle	1
	15-727	Switch Actuator	1
	15-728	Switch Body, On-Off-On	1
12	15-725	Mount Panel End	1
	15-727	Switch Actuator	1
	15-728	Switch Body, On-Off-On	1

Color Code Chart

Bl	Blue
Br	Brown
Y	Yellow
G	Green
O	Orange
R	Red
B	Black
P	Purple
W	White

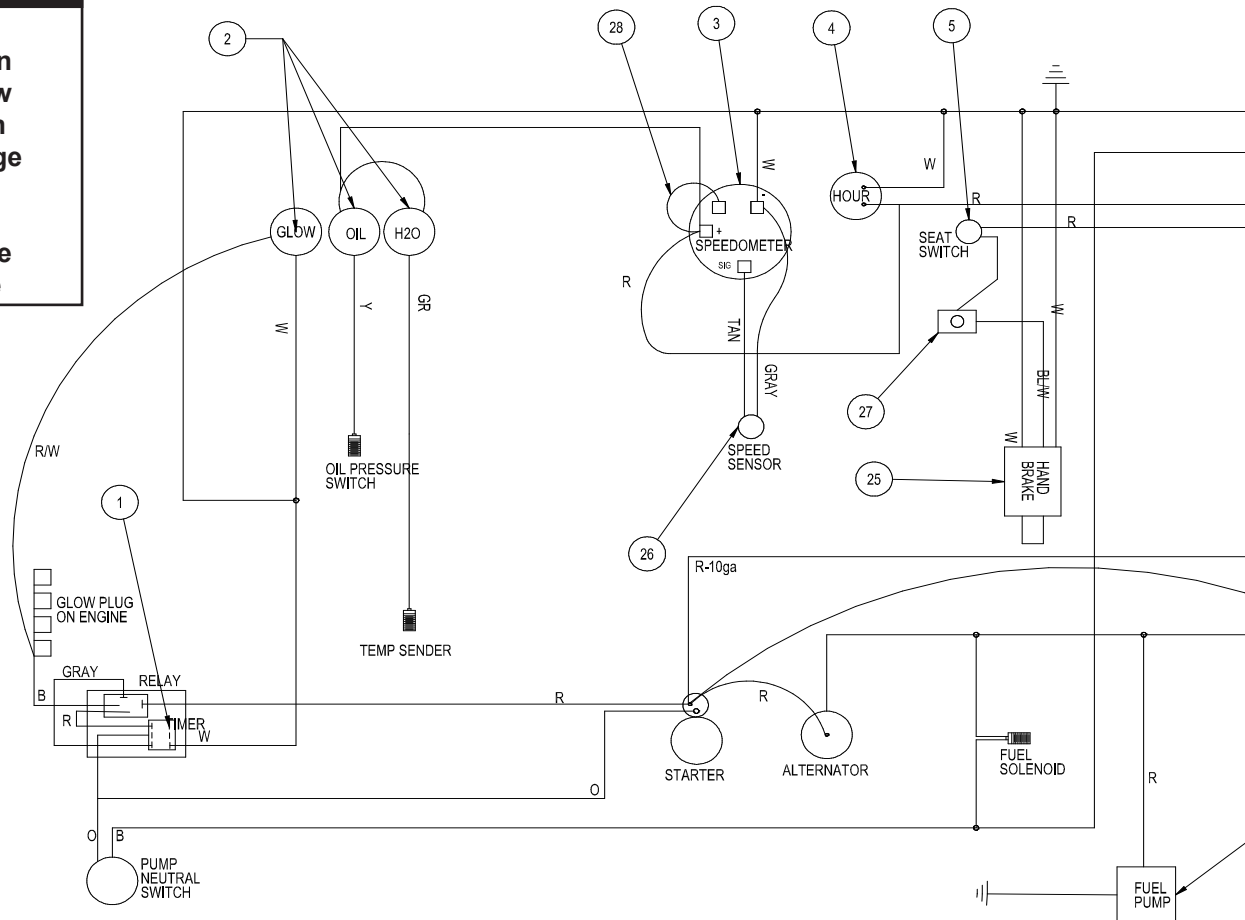

WIRING DIAGRAM

REF#	PART#	DESCRIPTION	QUANTITY
13	77-207	Buzzer	1
14	16-998	Hypro Pump	1
15	18-372	3-Way ball Valve	1
16	33-480	Pressure Switch	1
17	33-271	Buss Bar	1
	33-272	Fuse, 15 AMP	1
	33-273	Fuse, 30 AMP	2
18	33-509	Cruise Foot Switch	1
19	30-107	Wire Harness Battery ground to Fuse	1
20	33-084	Magnetic Coil	1
21	48-147	Ground Battery Cable	1
22	33-216	Battery	1
23	30-106	Wire Harness Battery to Fuse	1
24	76-326	Battery Cable	1
25	30-104	Manual Hand Brake	1
26	16-883	Speed Sensor	1
27	12-003	Park Brake Toggle Switch	1
	30-143	Toggle Switch Guard	1
28	31-071	Speedometer Wire	1
29	30-130	Fuel Pump	1
30	77-261	Circuit Breaker, 40 amp	1
NA	30-148	Main Wire Harness	1
NA	30-149	Engine Wire Harness	1

Service

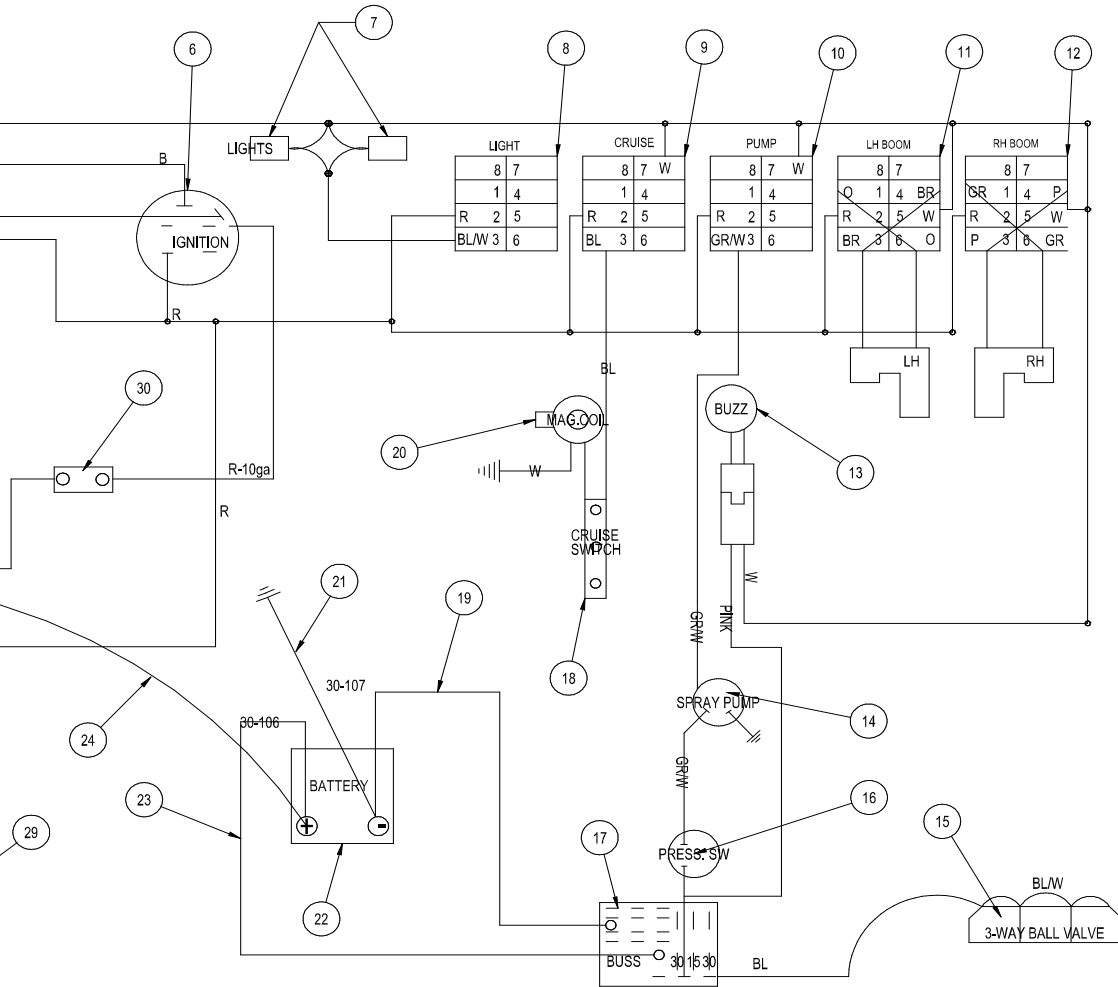

HYDRAULIC DIAGRAM

Use dielectric grease on all electrical connections.

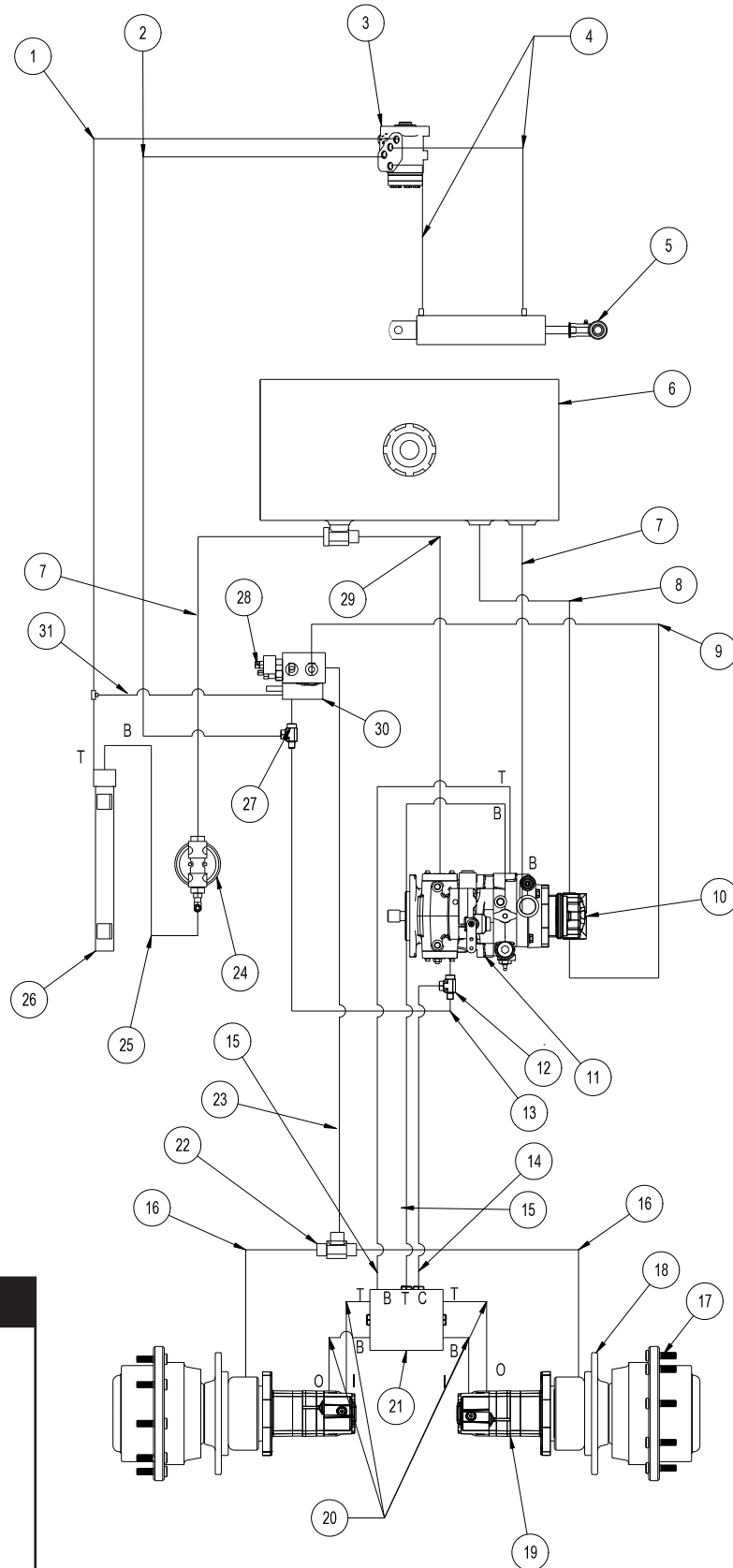

Letter Code Chart

C	Center
I	Inside
O	Outside
T	Top
B	Bottom

HYDRAULIC DIAGRAM PARTS LIST

REF#	PART#	DESCRIPTION	QUANTITY
1	30-156	Hydraulic Hose	1
2	30-091	Hydraulic Hose	1
3	15-301	Orbitrol	1
4	30-094	Hydraulic Hose	2
5	15-839	Hydraulic Cylinder	1
	14-531	Seal Kit	1
	18-171	³ / ₈ Seal Loc Adapter	2
6	30-025	Oil Tank	1
	13-747	Filler Breather	1
	13-586-03	Neck	1
7	8833-9	Suction Hose	2
	18-222	Hose Clamp	4
8	8833-17	Suction Hose	1
	18-222	Hose Clamp	2
9	30-093	Hydraulic Hose	1
10	30-098	Gear Pump	1
11	30-102	Eaton Closed Loop Pump	1
12	18-405	Run Tee	1
13	30-086	Hydraulic Hose	1
14	30-085	Hydraulic Hose	1
15	30-090	Hydraulic Hose	2
16	30-087	Hydraulic Hose	2
17	30-099	Wheel Drive	2
18	30-100	Hydraulic Release Brakes	2
19	30-101	Eaton Wheel Motors	2
20	30-089	Hydraulic Hose	4
21	30-103	Hot Oil Shuttle Manifold	1
22	18-395	Union Tee	1
23	30-088	Hydraulic Hose	1
24	60-215	Oil Filter Assembly	1
	60-334	Replacement Element	1
25	8833-23	Suction Hose	1
	18-222	Hose Clamp	2
26	30-105	Oil to Air Heat Exchanger	1
27	18-308	Swivel Tee	1
28	30-104	Brake and Manual Hand Pump Manifold	1
29	8917-15.5	Suction Hose	1
	18-040	Hose Clamp	2
30	30-181	Relief Valve	1
31	30-182	Hose	1

BODY & FRAME DRAWING

Diagrams

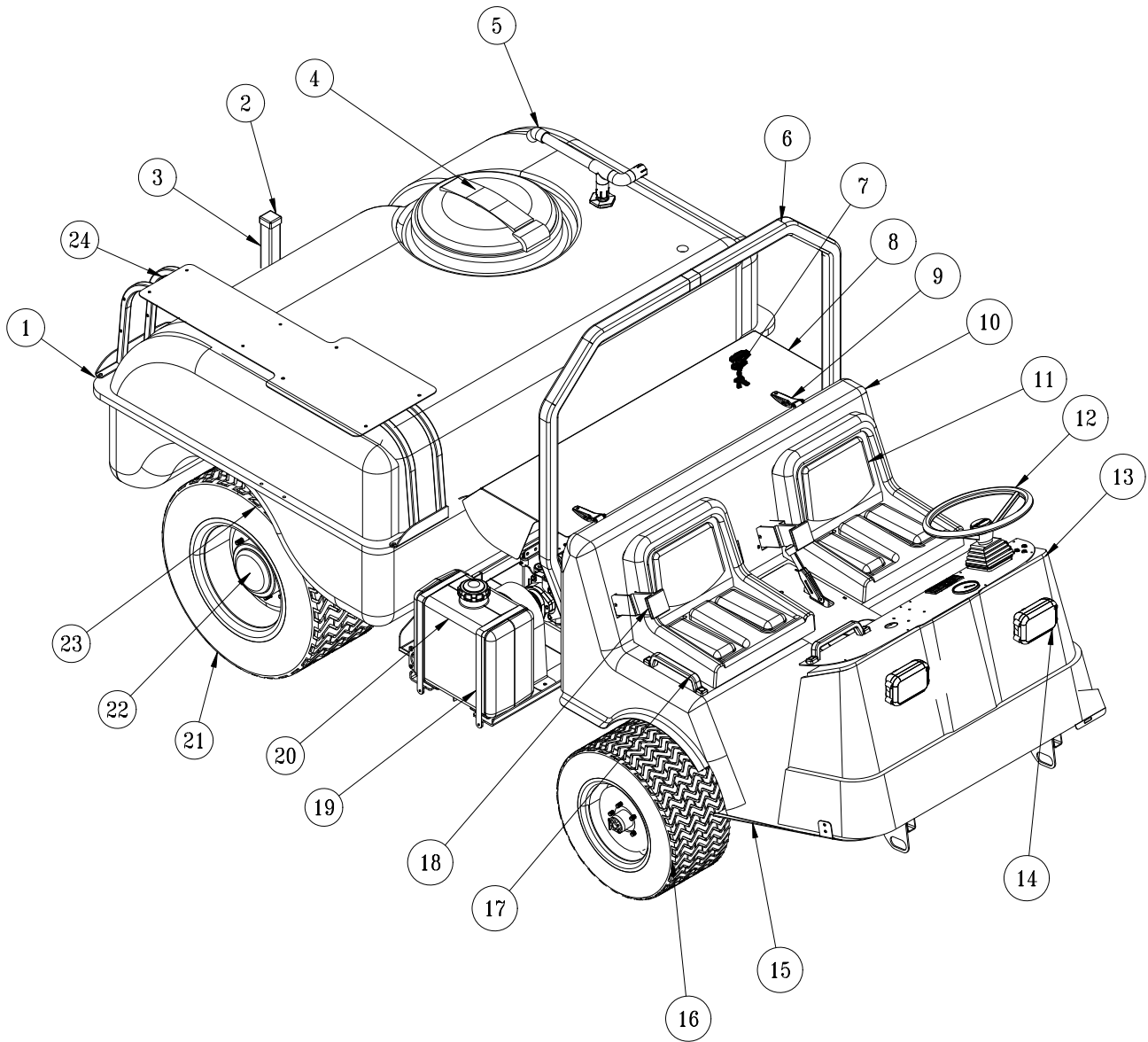

BODY & FRAME PARTS LIST

REF#	PART#	DESCRIPTION	QUANTITY
1	30-095	318 Gallon Tank (fiberglass)	1
	25-372	Decal, Smithco 4" Star	1
	30-016	Decal, Spray Star 3180	2
2	16-557	Square cap	2
3	14-325	Boom Carrier	2
	HB-12-13-150	Bolt $1\frac{1}{2}$ - 13 x $1\frac{1}{2}$	4
	HNFL-12-13	Flange Lock Nut $1\frac{1}{2}$ - 13	4
4	16--953	16" Hinged Lid Well	1
	16-953-01	Gasket for Lid	1
5	14-365	Air Gap Filler	1
6	30-008	Roll Bar	1
7	31-048	T-handle Latch	1
8	31-046	Engine Cover (fiberglass)	1
9	27-055	Flush Hinge	2
	HSM 10-32-100	Machine Screw #10-32-100	12
	HNFL-10-32	Flange Whiz Lock Nut # 10 - 32	12
10	31-045	Seat (fiberglass)	1
11	14-270	Seat	2
	14-292	Seat Switch	1
12	13-718	15" Steering Wheel	1
13	31-044	Nose Cone (fiberglass)	1
	50-400	Grommet	1
14	32-014	Head Lights	2
15	30-155	Main Frame	1
16	43-124	Turf Tread Tire and Wheel	2
	43-123-01	Tire	2
	43-058-01	Wheel	2
	HNL-12-20	Lug Nut $1\frac{1}{2}$ - 20	14
17	76-443	Handle	3
18	76-198-03	Seat Belt	1
19	73-051	Fuel Tank Strap	2
20	73-049	Fuel Tank	1
	73-050	Fuel Cap	1
21	30-048-01	Rear Tire	2
22	30-048-02	Rear Wheel	2
	HNL-12-20	Lug Nut $1\frac{1}{2}$ - 20	14
23	30-110	Accessory Mount Bracket	1
	HB-516-18-175	Bolt $\frac{5}{16}$ - 18 x $1\frac{3}{4}$	4
	HW-516	Washer $\frac{5}{16}$	4
	HNFL-516-18	Flange Lock Nut $\frac{5}{16}$ - 18	4

NOSE CONE DRAWING

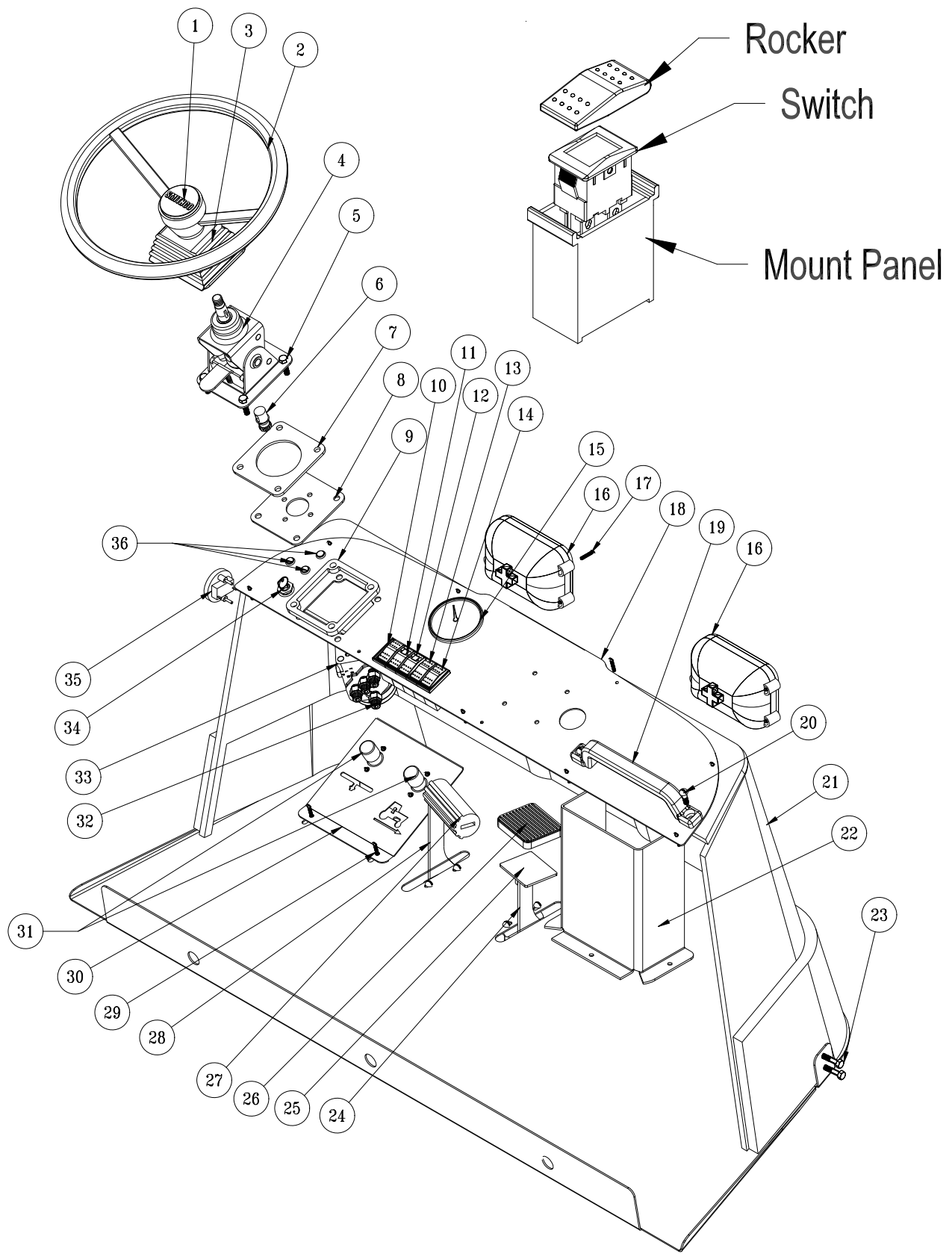

PARTS

NOSE CONE PARTS LIST

REF#	PART#	DESCRIPTION	QUANTITY
1	13-726	Center Cap	1
	27-077	Decal, Smithco Round	1
2	13-718	15" Steering Wheel	1
3	76-364	Square Boot	1
4	76-362	Mini Tilt steering	1
5	HB-516-18-125	Bolt $\frac{5}{16}$ - 18 x $1\frac{1}{4}$	4
	HNFL-516-18	Flange Whiz Lock Nut $\frac{5}{16}$ -18	4
6	48-187	Stub shaft	1
7	15-844	Tilt Steering Spacer	1
8	31-056	Tilt Steering Plate	1
9	31-057	Steering Spacer	1
10	LIGHTS		
	15-725	Mount Panel End	1
	15-727	Actuator, No Light	1
	15-782	Rocker Switch, Unlit	1
11	CRUISE		
	15-731	Actuator, Amber	1
	15-726	Switch Body, Light	1
	15-729	Mount Panel Middle	1
12	PUMP		
	15-732	Actuator, Green	1
	15-726	Switch Body, Light	1
	15-729	Mount Panel Middle	1
13	RIGHT BOOM		
	15-727	Actuator, No Light	1
	15-729	Mount Panel Middle	1
	15-728	Switch Body, Momentary On-Off-On	1
14	LEFT BOOM		
	15-725	Mount Panel End	1
	15-727	Actuator, No Light	1
	15-728	Switch Body, Momentary On-Off-On	1
15	10-556	Speedometer	1
16	32-014	Head Light	2
17	HSM-10-32-100	Machine Screw #10 -32 x 1	8
	HNFL-10-32	Flange Whiz Lock Nut #10 -32	8
18	20-596	Dash Panel	1
	20-545	Decal, Dash Panel	1
	50-400	Grommet	1
	HSM-10-32-100	Machine Screw #10 -32 x 1	9
	HNFL-10-32	Flange Whiz Lock Nut #10 -32	9
19	76-443	Black Handle	1
20	HSTP-516-18-100	Phillips Machine Screw $\frac{5}{16}$ -18 x 1	2
	HNFL-516-18	Flange Whiz Lock Nut $\frac{5}{16}$ -18	2
21	31-044	Nose Cone (fiberglass)	1
22	31-062	Hose Guard	1
23	HSTP-516-18-150	Phillips Machine Screw $\frac{5}{16}$ -18 x $1\frac{1}{2}$	7
	HNFL-516-18	Flange Whiz Lock Nut $\frac{5}{16}$ -18	7
24	31-050	Reverse Pedal	1
25	16-062	Pedal Pad Plate	1
	HB-38-16-125	Bolt $\frac{3}{8}$ -16 x $1\frac{1}{4}$	1
26	15-015	Pedal Pad	1

(Continued on next page)

NOSE CONE DRAWING

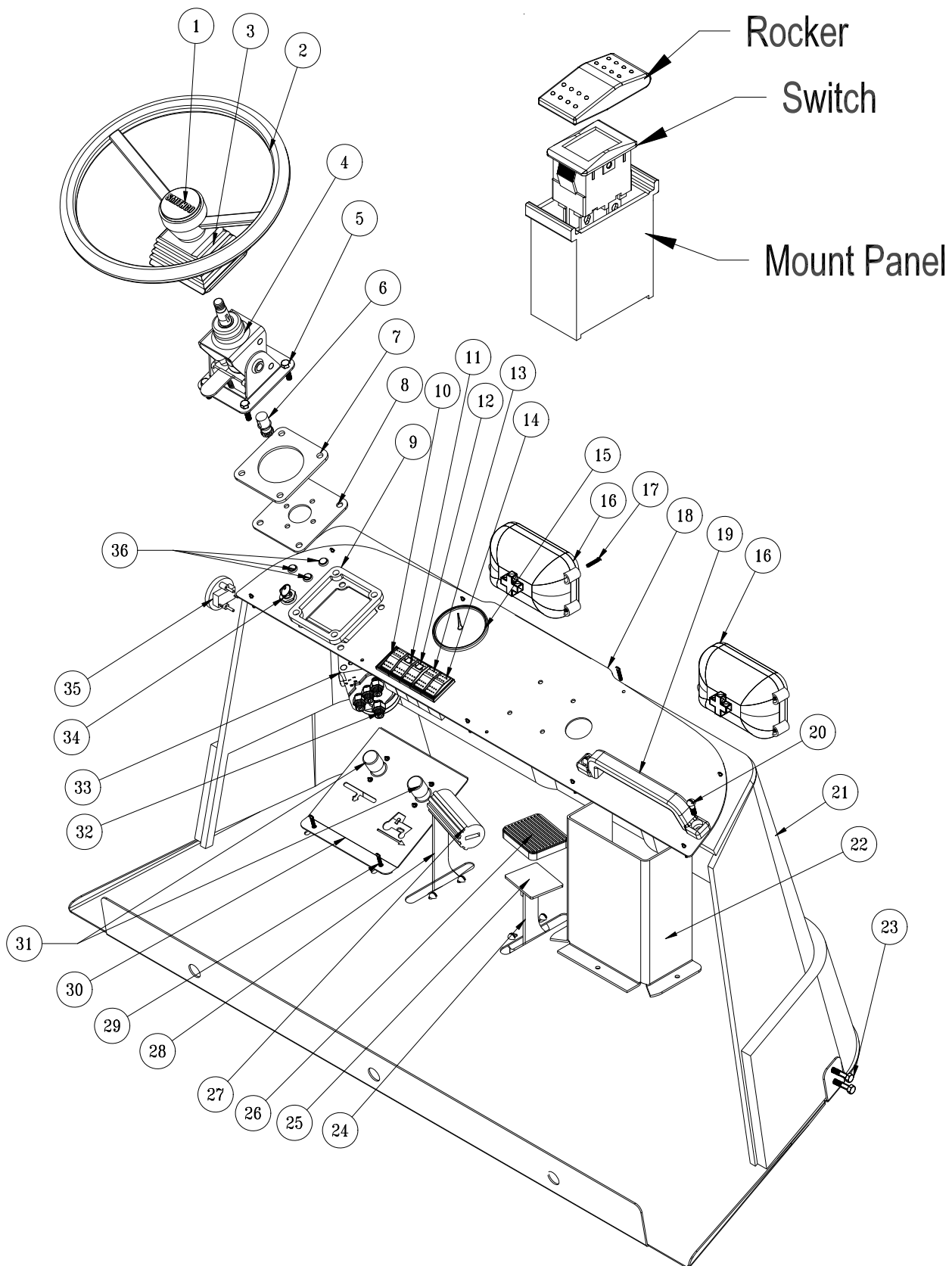

PARTS

NOSE CONE PARTS LIST

REF#	PART#	DESCRIPTION	QUANTITY
27	48-066	Pedal Grip	1
28	10-163	Forward Foot Pedal	1
29	HB-14-20-075	Bolt $\frac{1}{4}$ -20 x $\frac{3}{4}$	2
	HNFL-14-20	Flange Whiz Lock Nut $\frac{1}{4}$ - 20	2
30	31-049	Button Plate	1
31	33-509	Master Control Switch	2
	HSTP-14-20-075	Machine Screw $\frac{1}{4}$ -20 x $\frac{3}{4}$	4
32	7-867	SAE # 6 Adapter	4
33	15-301	Orbitrol	1
34	13-488	Ignition	1
35	12-017	Hour Meter	1
36	50-359	Warning Indicator Light	3

LINKAGE DRAWING

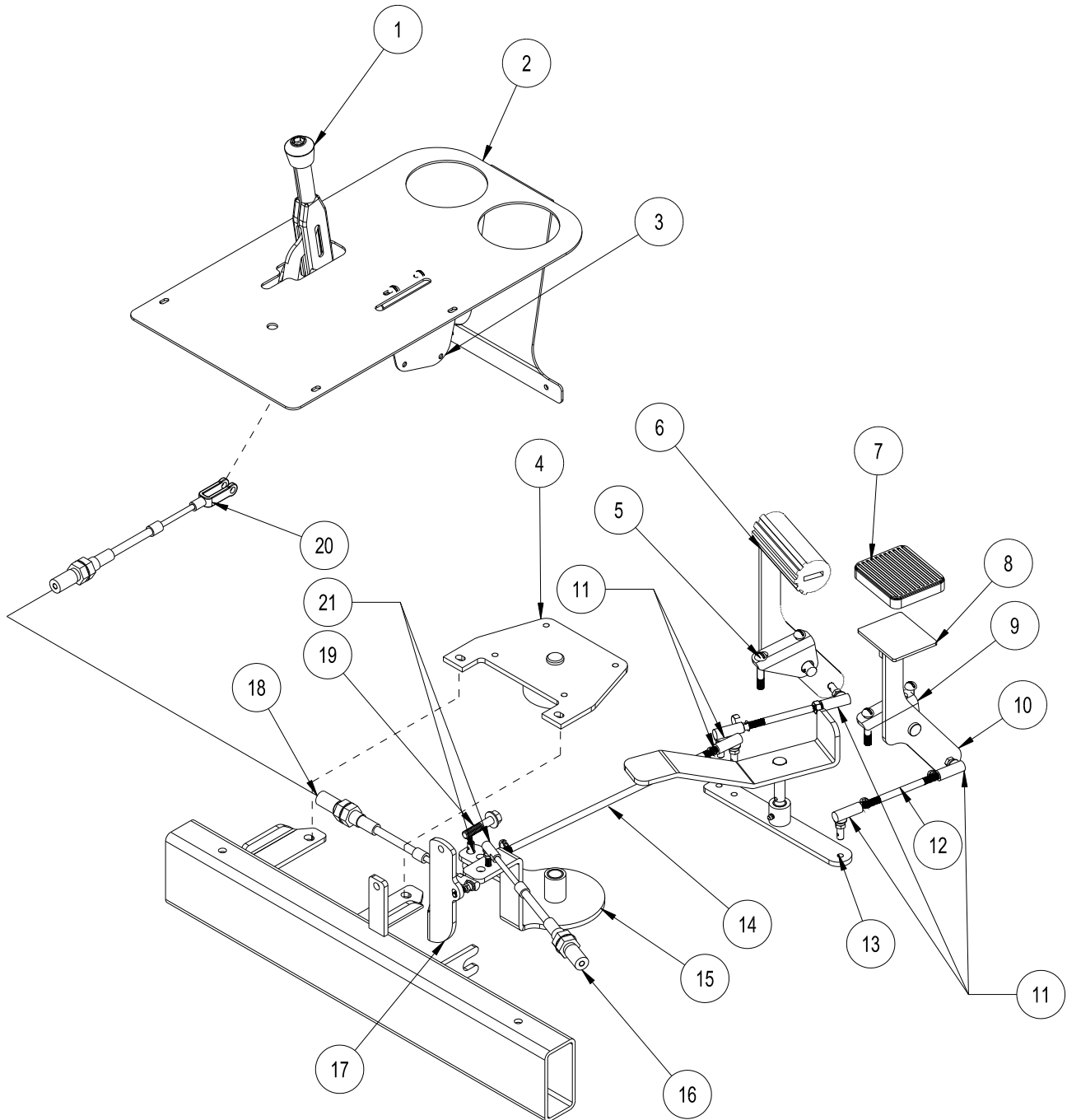

PARTS

LINKAGE PARTS LIST

REF#	PART#	DESCRIPTION	QUANTITY
1	60-106	Control Lever	1
	34-021	Linkage Rod	1
	HN-516-24	Nut $\frac{5}{16}$ - 24	1
2	30-153	Center Console	1
3	42-766	Throttle Bracket	1
4	30-027	Relay Plate	1
5	HSTP-516-18-075	Phillips Machine Screw $\frac{5}{16}$ -18 x $\frac{3}{4}$	4
	HNFL-516-18	Flange Whiz Lock Nut $\frac{5}{16}$ -18	4
6	10-163	Forward Foot Pedal	1
	48-066	Pedal Grip	1
7	15-015	Pedal Pad	1
8	16-062	Pedal Pad Plate	1
	HB-38-16-125	Bolt $\frac{3}{8}$ -16 x $1\frac{1}{4}$	1
9	76-296	Pedal Mount	2
	18-234	Bushing	4
	HG-14-28-180	Grease Zerk	2
10	31-050	Reverse Pedal	1
11	21-462	Ball Joints	6
	HN-516-24	Nut $\frac{5}{16}$ - 24	6
12	31-054	Pedal Rod	2
13	10-178	Relay	1
	18-234	Bushing	2
	HG-14-28-180	Grease Zerk	1
14	31-055	Linkage Rod	1
15	15-692	Pedal Relay	1
16	13-632	Push Pull Cable	1
17	30-159	Spray Boss Arm	1
18	30-152	Push-Pull Cable	1
19	HB-516-18-100	Bolt $\frac{5}{16}$ -18 x 1	1
	HW-516	Washer	4
	HNTL-516-18	Lock Nut $\frac{5}{16}$ -18	1
20	11-103	Linkage Yoke	1
	HN-516-24	Nut $\frac{5}{16}$ - 24	1
21	8-701	Ball Joint	2
	HN-14-20	Nut $\frac{1}{4}$ - 20	2

FRONT AXLE DRAWING

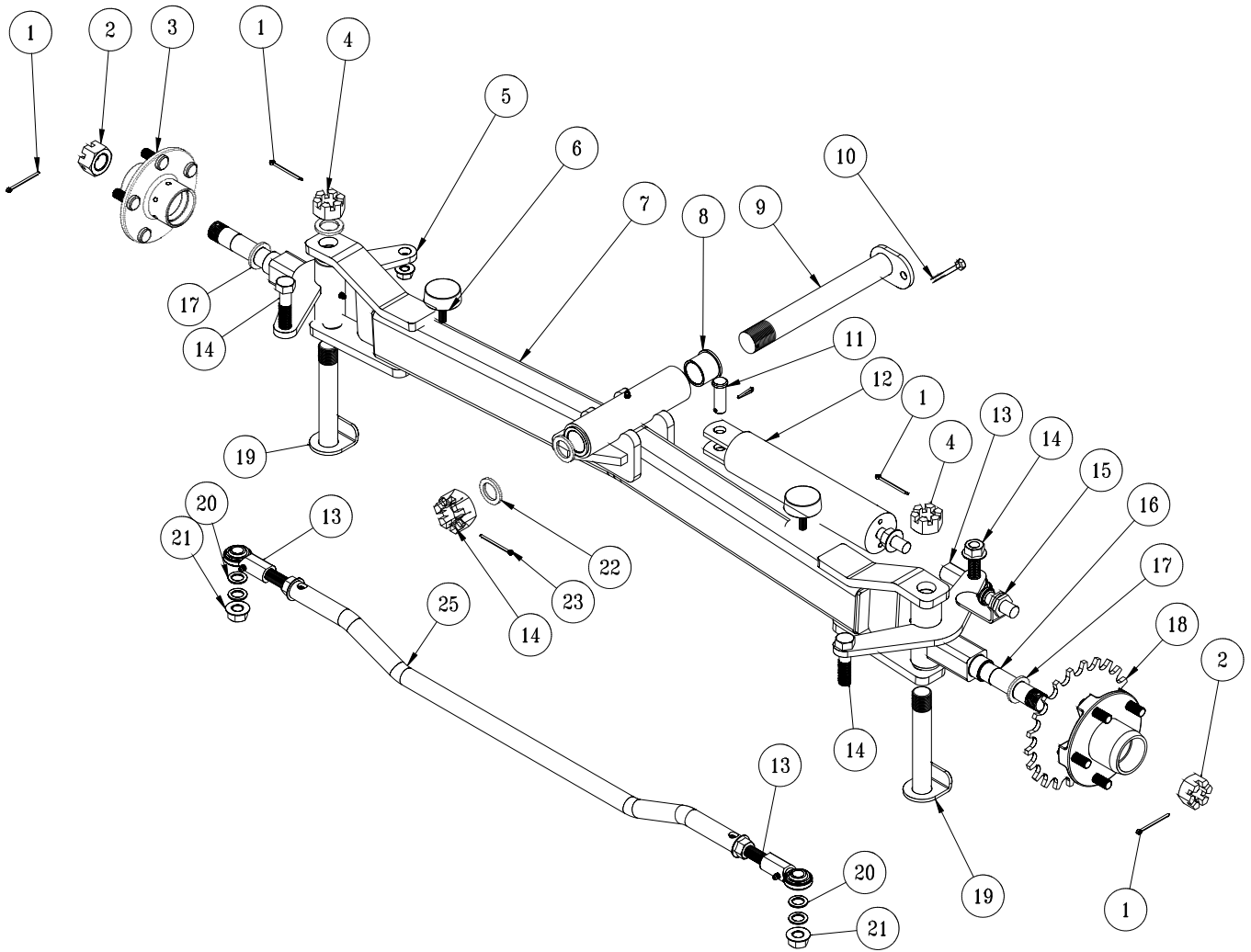

PARTS

FRONT AXLE PARTS LIST

REF#	PART#	DESCRIPTION	QUANTITY
1	HP-18-150	Cotter Pin $\frac{1}{8}$ - $1\frac{1}{2}$	2
2	HNJ-58-18	Jam Nut $\frac{5}{8}$ - 18	2
3	30-071	Hub Assembly	1
4	HNAR-100-14	Slotted Jam Nut 1 - 14	2
5	30-070	Left Spindle	1
6	50-081	Rubber Insulator	2
7	30-039	Front Axle	1
8	18-153	Bushing (part of 30-039)	2
9	14-344	Axle Pin	1
10	HB-516-18-125	Bolt $\frac{5}{16}$ - 18 x $1\frac{1}{4}$	1
	HNTL-516-18	Lock Nut $\frac{5}{16}$ - 18	1
11	HCP-58-175	Clevis Pin $\frac{5}{8}$ x $1\frac{3}{4}$	1
	HP-18-100	Cotter Pin $\frac{1}{8}$ x 1	1
12	15-839	Hydraulic Cylinder	1
	14-531	Seal Kit	1
	18-171	$\frac{3}{8}$ Seal Loc Adapter	2
13	18-154	Rod End	3
	HG-14-28-90	Grease Fitting $\frac{1}{4}$ - 28 x 90°	3
14	HB-58-11-250	Bolt $\frac{5}{8}$ - 11 x $2\frac{1}{2}$	3
15	16-883	Magnetic Sensor	1
16	30-069	Right Spindle	1
17	HMB-100-10	Machine Bushing 1 x 10GA	6
18	30-072	Hub with Sprocket	1
19	16-076	King Pin	2
20	HMB-58-14	Machine Bushing $\frac{5}{8}$ x 14GA	6
21	HNTL-58-11	Lock Nut $\frac{5}{8}$ - 11	3
22	HMB-114-10	Machine Bushing $1\frac{1}{4}$ x 10GA	2
23	HP-18-200	Cotter Pin $\frac{1}{8}$ x 2	1
24	HNAT-114-12	Axle Nut $1\frac{1}{4}$ - 12	1
25	15-690	Tie Rod	1

OIL AND FUEL TANK DRAWING

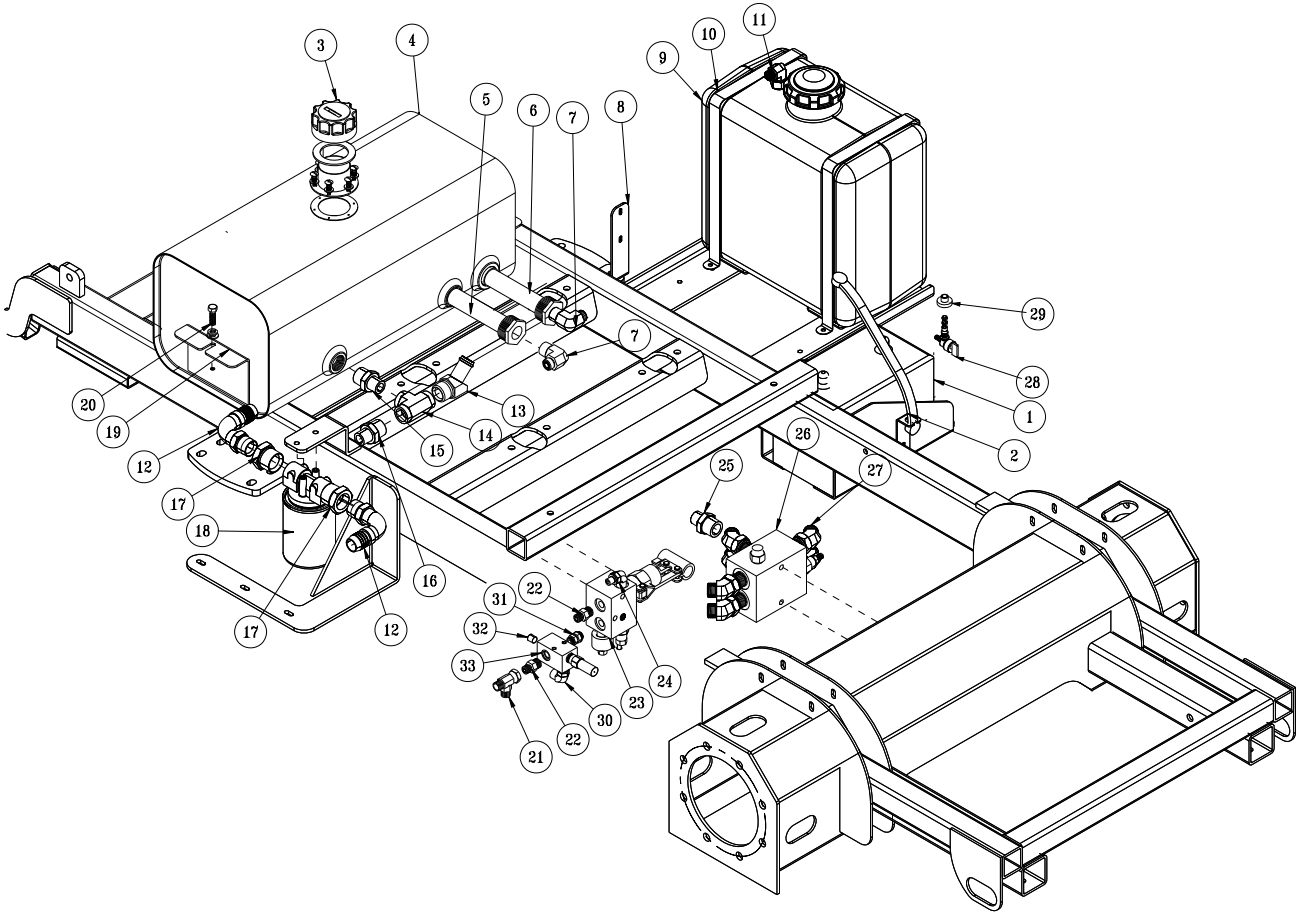

PARTS

OIL AND FUEL TANK PARTS LIST

REF#	PART#	DESCRIPTION	QUANTITY
1	33-216	Battery	1
2	8-603	Battery Hold Down	1
3	13-747	Filler Breather	1
	13-586-03	Fuel Tank Neck	1
	HSM-10-32-063	Machine Screw #10-32 x 5/8	6
	HWL-10	Lock Washer #10	6
4	30-025	Oil Tank	1
	18-069	Pipe Plug	1
5	18-433	Strainer	1
6	60-213	Strainer	1
7	18-398	90° Barb Fitting	2
8	30-132	Fuel Pump Mount	1
9	73-049	Fuel Tank	1
	73-050	Cap with Gauge	1
10	73-051	Fuel Tank Strap	2
	HB-14-20-075	Bolt 1/4 - 20 x 3/4	2
	HB-14-20-150	Bolt 1/4 - 20 x 1 1/2	2
	HNFL-14-20	Flange Lock Nut 1/4 - 20	4
11	30-125	Top Draw Tube	1
	9025-44	3/16 Fuel Hose 44"	
12	18-397	90° Hose Barb Fitting	2
13	18-407	5/8 45° Hose Barb Fitting	1
14	18-399	Tee	1
15	18-400	Pipe Nipple	1
16	18-250	Barb Fitting	1
17	18-396	Reducer	2
18	60-215	Oil Filter Assembly	1
	60-334	Replacement Filter	1
19	30-063	Oil Tank Hold-down	2
20	HB-38-16-125	Bolt 3/8 -16 x 1 1/4	2
	HWL-38	Lock Washer 3/8	2
	HW-38	Washer 3/8	2
21	18-308	Swivel Tee	1
22	18-306	Straight Thread Connector	2
23	30-104	Manual Brake Pump Manifold	1
24	18-171	Seal Lock Elbow	1
25	18-321	Straight thread Connector	1
	23-126	O-ring plug	1
26	30-103	Hot Oil Shuttle Manifold	1
27	18-393	Elbow	6
28	26-054	Bushing Insert	1
29	26-055	Shut Off Valve	1
30	18-171	Elbow	1
31	18-317	Union Fitting	1
32	18-444	1/4 Hollow Plug	1
33	30-181	Relief Valve	1

SEAT PANEL DRAWING

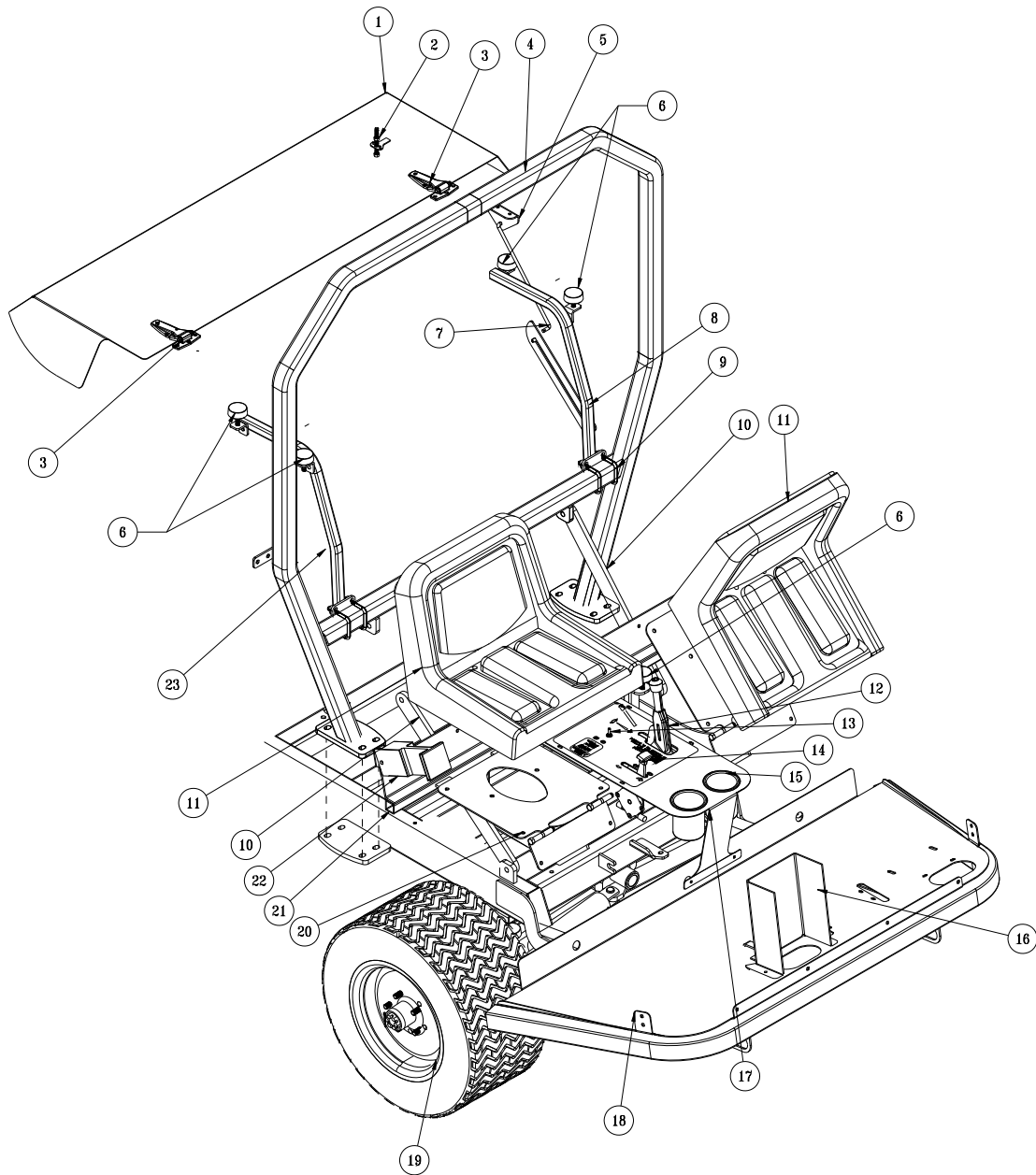

PARTS

SEAT PANEL PARTS LIST

REF#	PART#	DESCRIPTION	QUANTITY
1	31-046	Engine Cover (fiberglass)	1
2	31-048	T-Handle Latch	1
3	27-055	Flush Hinge	2
	HSM 10-32-100	Machine Screw #10-32-100	12
	HNFL-10-32	Flange Whiz Lock Nut # 10 - 32	12
4	31-063	Roll Bar	1
5	31-058	Rod Pivot	1
6	50-081	Rubber Bumper	8
	HNFL-38-16	Flange Whiz Lock Nut $\frac{3}{8}$ -16	8
7	31-059	Hood Rod	1
	HW-516	Washer $\frac{5}{16}$	2
	HP-18-100	Cotter Pin $\frac{1}{8}$ x 1	2
8	31-065	LH Hood Support	1
9	17-537	U-Bolt	4
	HW-38	Washer $\frac{3}{8}$	8
	HNFL-38-16	Flange Whiz Lock Nut $\frac{3}{8}$ - 16	8
10	30-032	Roll Bar Brace	2
11	14-270	Seat	2
12	60-106	Park Brake Handle Kit	1
13	12-003	Toggle Switch	1
	30-143	Toggle Switch Guard	1
14	34-160	Throttle Cable	1
	42-766	Throttle Bracket	1
15	15-781	Drink Cup Holder	2
16	31-062	Hose Cover	1
17	30-153	Center Console	1
	30-157	Decal, Console	1
18	30-155	Main Frame	1
19	43-124	Turf Tread Tire and Wheel	2
	43-123-01	Tire	2
	43-058-02	Wheel	2
20	31-052	Seat Panel	2
21	31-066	Seat Frame	1
22	76-198-03	Seat Belt	2
23	31-064	RH Hood Support	1

ENGINE AND PUMPS DRAWING

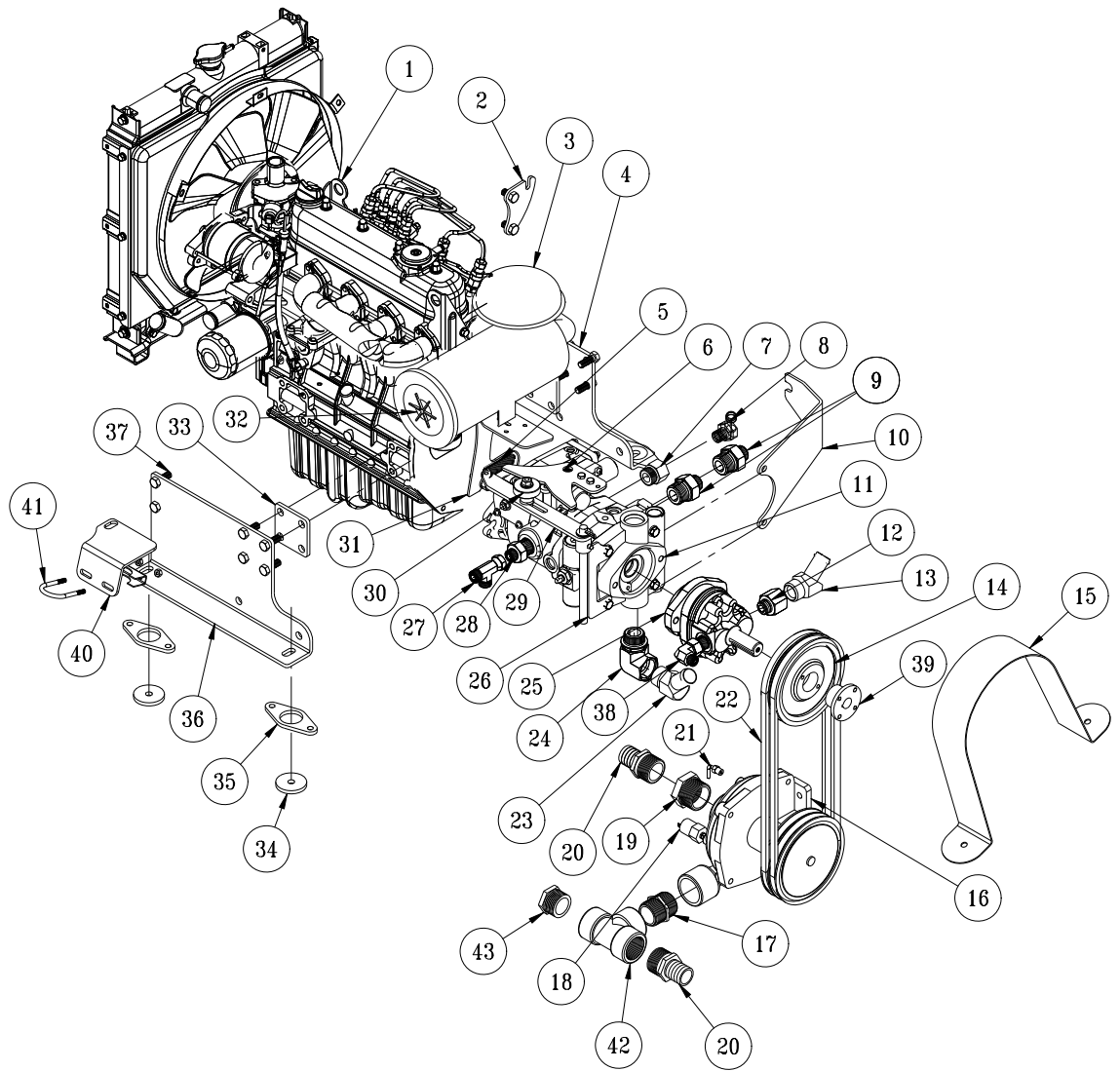

PARTS

ENGINE, AND PUMPS PARTS LIST

REF#	PART#	DESCRIPTION	QUANTITY
1	30-042	Kubota Diesel Engine 33.5 HP	1
	23-145	O-ring	1
2	30-033	Throttle Cable Mount	1
	HBM-10-1.5-20	Bolt #10 - 1.5 x 20	2
	HWLM-10	#10 Lock Washer	2
3	42-004-02	Air Cleaner Cap	1
4	30-041	Right Engine Mount	1
5	48-109	Spring	1
6	30-037	Shift Arm	1
	HB-14-20-075	Bolt $\frac{1}{4}$ - 20 x $\frac{3}{4}$	2
	HNCL-14-20	Center Lock Nut $\frac{1}{4}$ - 20	2
7	18-333	Adapter	1
8	23-143	Connector	1
9	18-403	Adapter	2
10	30-031	Cable Mount	1
11	30-102	Eaton Closed Loop Pump	1
12	18-349	Straight Thread Reducer	1
13	23-190	45° Elbow $\frac{3}{4}$ MPT	1
14	30-135	Pulley	1
15	30-067	Belt Guard	1
	HB-516-18-100	Bolt $\frac{5}{16}$ -18 x 1	2
	HNFL-516-18	Flange Lock Nut $\frac{5}{16}$ -18	2
16	16-998	Hypro Spray Pump	1
	30-139	Pump Mount	1
	HB-38-16-150	Bolt $\frac{3}{8}$ -16 x $1\frac{1}{2}$	2
	HNFL-38-16	Flange Lock Nut $\frac{3}{8}$ -16	2
17	16-880	Nipple	1
18	33-480	Pressure Switch	1
19	16-825	Hex Bushing	1
20	16-161	Hose Barb Fitting	2
21	33-494	Male Elbow	1
22	30-137	Belt	2
23	23-190	Elbow	1
24	23-191	Elbow	1
25	30-204	Gear Pump	1
	30-098-01	Seal Kit	1
26	30-029	Centering Arm Mount	1
29	30-082	Idler Arm	1
	HMB-12-14	Machine Bushing $\frac{1}{2}$ -14GA	
	HP-18-075	Cotter Pin $\frac{1}{8}$ x $\frac{3}{4}$	1
28	18-404	Adapter	1
27	18-405	Run Tee	1
30	14-266	Ball Bearing	1
	48-049	Shift Arm Spacer	1
	HB-38-16-200	Bolt $\frac{3}{8}$ -16 x 2	1
	HW-38	Washer $\frac{3}{8}$	2
	HN-38-16	Nut $\frac{3}{8}$ - 16	1
31	30-036	Timer Spring Mount	1
	HB-12-13-125	Bolt $\frac{1}{2}$ - 13 x $1\frac{1}{2}$	1
	HWL-12	Lock Washer $\frac{1}{2}$	1

(Continued on Next Page)

ENGINE AND PUMPS DRAWING

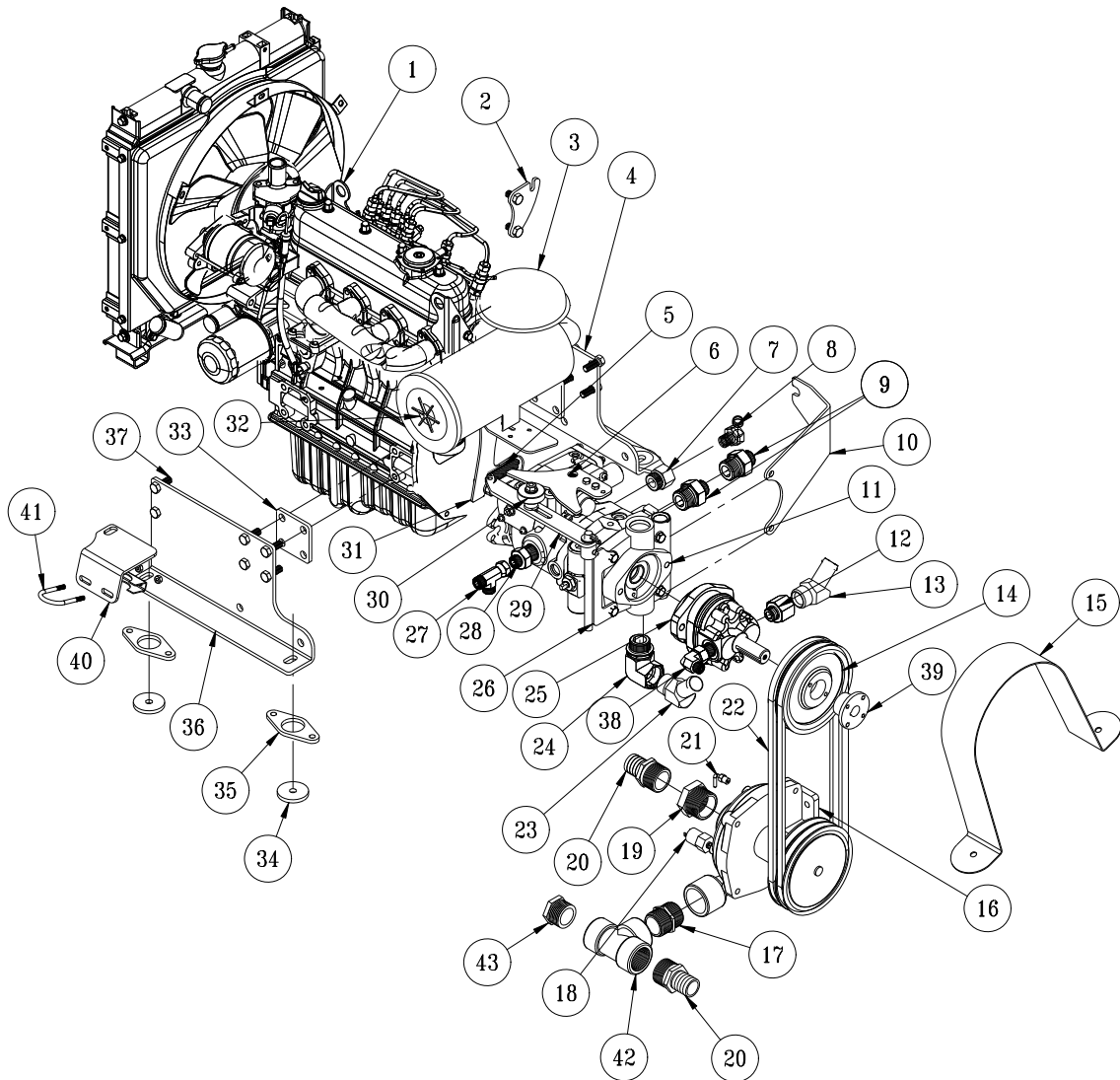

PARTS

ENGINE, AND PUMPS PARTS LIST

REF#	PART#	DESCRIPTION	QUANTITY
32	30-042-02	Air Cleaner	1
	30-042-05	Element	1
33	30-038	Kubota Spacer	2
34	30-064	Motor Washers	4
	HB-716-14-300	Bolt $\frac{7}{16}$ - 14 x 3	4
	HW-716	Washer $\frac{7}{16}$	4
	HNTL-716-14	Lock Nut $\frac{7}{16}$	4
35	30-042-01	Spacers	4
	HB-38-16-100	Bolt $\frac{3}{8}$ - 16 x 1	8
	HNFL-38-16	Flange Lock Nut $\frac{3}{8}$ - 16	8
36	30-040	Left Engine Mount	1
37	HBM-10-1.5-30	Bolt #10 - 1.5 x 30	12
	HWLM-10	#10 Lock Washer	12
38	18-350	$\frac{3}{8}$ Elbow	1
39	30-136	Hub	1
40	31-042	Muffler Support	1
41	50-111	Muffler Clamp	1
42	18-390	Tee	1
43	10-389	Plug	1

COOLER AND EXHAUST DRAWING

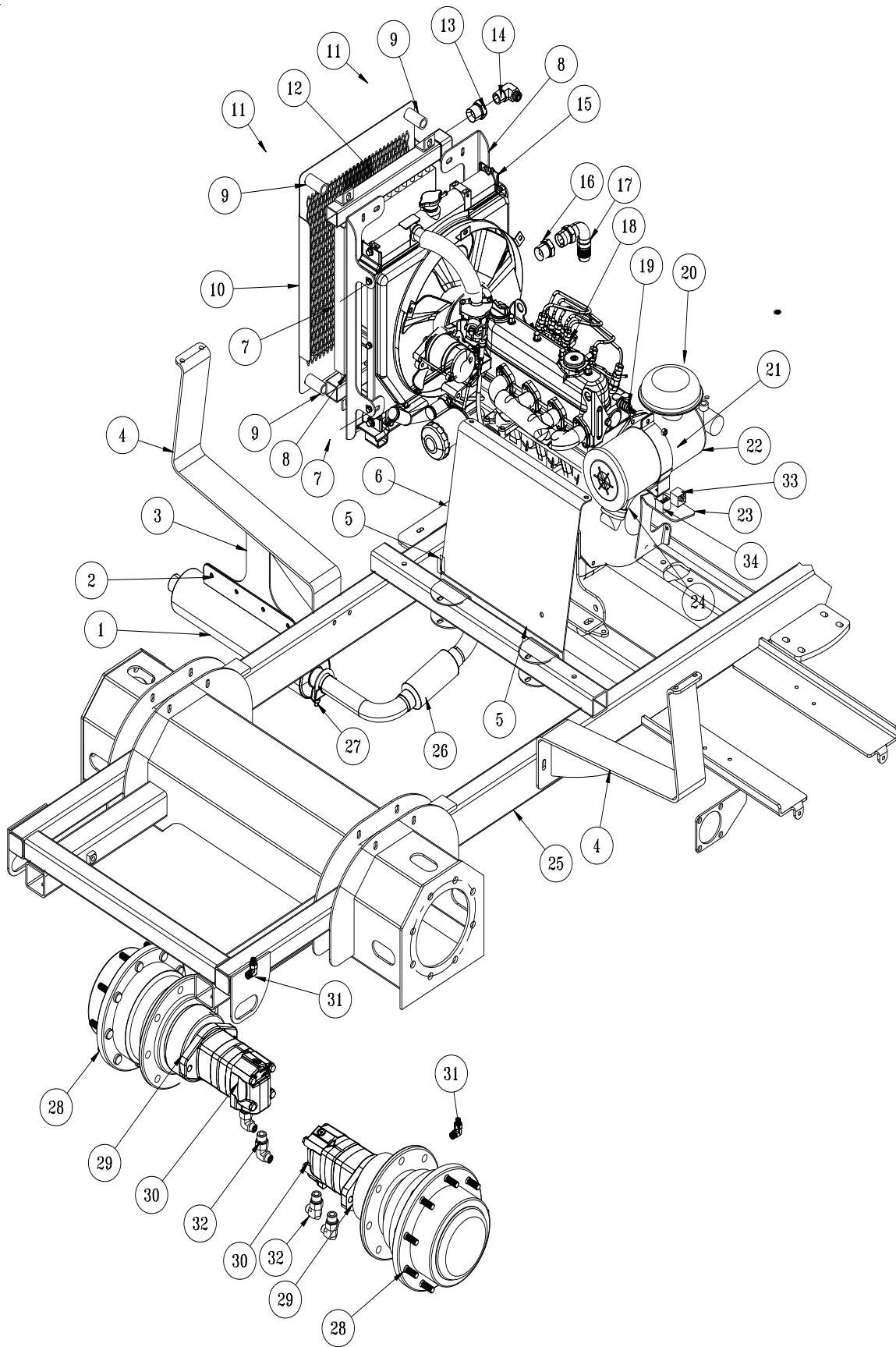

PARTS

COOLER AND EXHAUST PARTS LIST

REF#	PART#	DESCRIPTION	QUANTITY
1	30-133	Muffler	1
2	HBFL-516-18-075	Flange Bolt $\frac{5}{16}$ - 18 x $\frac{3}{4}$	4
	HNFL-516-18	Flange Lock Nut $\frac{5}{16}$ - 18	4
3	30-131	Muffler Hanger	1
4	30-052	Tank Carrier	2
5	HB-38-16-300	Bolt $\frac{3}{8}$ - 16 x 3	2
	HW-38	Washer $\frac{3}{8}$	2
	HNFL-38-16	Flange Lock Nut $\frac{3}{8}$ - 16	2
6	30-050	Front Tank Mount	1
7	HBM-6-1-16	Metric Bolt M6 - 1 - 16	4
	HWLM-6	Metric Washer M6	4
	HW-14	Washer $\frac{1}{4}$	4
8	30-028	Cooler Mount	2
9	60-406	Spacer	4
10	30-043	Oil Cooler Cover	1
11	HB-38-16-275	Bolt $\frac{3}{8}$ - 16 x $2\frac{3}{4}$	4
	HNFL-38-16	Flange Lock Nut $\frac{3}{8}$ - 16	4
12	30-105	Thermal Transfer Heat Exchanger	1
13	18-107	Pipe Thread Reducer	1
14	18-402	$\frac{3}{4}$ x 90° Hose Barb	1
15		Radiator	1
16	18-408	Tube End Reducer	1
17	18-397	90° Hose Barb	1
18	30-042	Kubota 33.5 HP Diesel Engine	1
19		Hardware	
20	42-004-02	Air Cleaner Cap	1
21	30-042-03	Clamp	1
22	30-042-02	Air Cleaner Body	1
	30-042-05	Element	1
	30-042-07	Inlet Hose	1
23	30-036	Timer/Spring Mount	1
24	30-042-04	Evacuator Valve	1
25	30-155	Main Frame	1
26	30-134	Manifold Pipe	1
	77-217	Exhaust Manifold Gasket	1
	48-214	Exhaust Wrap	60"
	18-222	Hose Clamp	2
27	50-111	Clamp	1
28	30-099	Auburn Wheel Drive	2
29	30-100	Micro Spring Hydraulic Brakes	2
30	30-101	Eaton 2000 Series Hydraulic Motor	2
	30-101-11	Seal Kit	2
31	18-394	Elbow	2
32	18-301	Straight Thread Elbow	4
33	30-042-06	Relay (part of engine)	1
34	77-223	Timer (part of engine)	1

TANK DRAWING

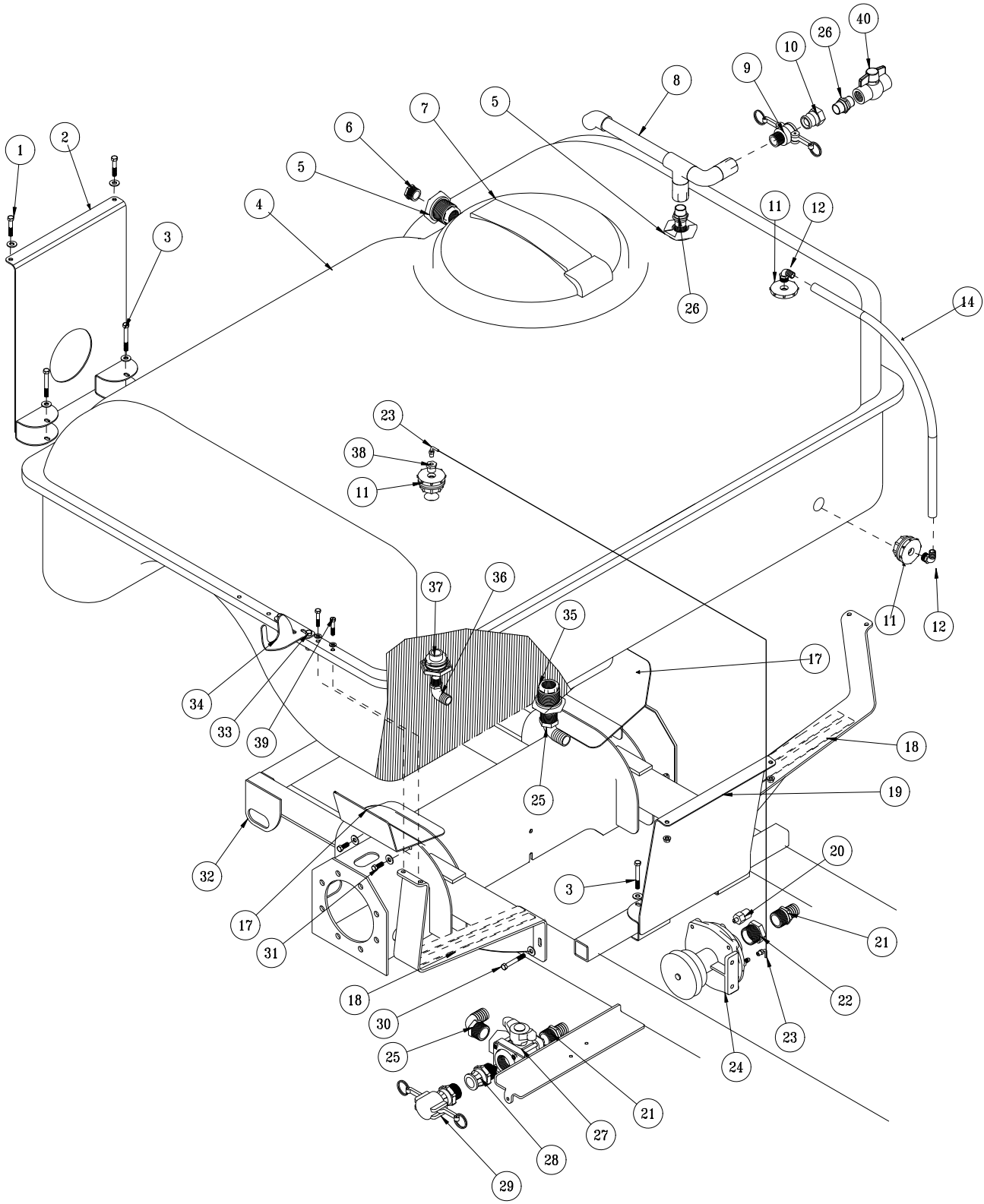

PARTS

TANK PARTS LIST

REF#	PART#	DESCRIPTION	QUANTITY
1	HB-38-16-200	Bolt $\frac{3}{8}$ - 16 X 2	4
	HW-38	Washer $\frac{3}{8}$	4
	HNFL-38-16	Lock Nut $\frac{3}{8}$ - 16	4
2	30-051	Rear Tank Mount	1
	8828-16	Foam Tape	1
3	HB-38-16-300	Bolt $\frac{3}{8}$ - 16 x 3	4
	HW-38	Washer $\frac{3}{8}$	4
	HNFL-38-16	Flange Lock Nut $\frac{3}{8}$ - 16	4
4	30-095	318 Gallon Tank (fiberglass)	1
5	16-945	Double Thread Fitting	2
6	16-162	Hex Plug 1" (Inside tank below air gap filler)	2
7	16-953	Hinged Lid Well	1
	16-953-01	Gasket for Cover	1
	16-169	Strainer Basket	1
8	14-365	Air Gap Filler	1
9	16-962	1" Coupler	1
10	16-961	1" Adapter	1
11	33-495	Bulkhead Fitting	3
12	16-937	Elbow	2
14	8902-28	Clear Flo Tubing	1
	30-019	Decal, Site Gauge	1
17	30-062	Rear Tank Support	2
	30-166	Tank Pad	2
18	30-052	Tank Carrier	2
	8828-26	Foam Tape	4
19	30-050	Front Tank Mount	1
	8828-16	Foam Tape	1
20	33-480	Pressure Switch	1
21	16-161	Fitting	2
22	16-825	Hex Bushing	1
23	33-494	Male Elbow	2
	8954-44	Clear Hose	1
	18-116	Hose Clamp	2
24	16-998	Hypro Pump	1
25	16-156	Elbow	1
26	16-851	Close Nipple	1
27	18-372	3-Way Valve	1
	18-372-01	Handle	1
28	16-180	Quick Coupler Male	1
29	16-935	Quick Coupler Cap	1
30	HB-38-16-275	Bolt $\frac{3}{8}$ - 16 x $2\frac{3}{4}$	4
	HW-38	Washer $\frac{3}{8}$	4
	HNFL-38-16	Flange Lock Nut $\frac{3}{8}$ - 16	4
31	HB-38-16-100	Bolt $\frac{3}{8}$ - 16 x 1	4
	HW-38	Washer $\frac{3}{8}$	4
	HNFL-38-16	Flange Lock Nut $\frac{3}{8}$ -16	4
32	30-155	Main Frame	1
33	HB-38-16-150	Bolt $\frac{3}{8}$ - 16 x $1\frac{1}{2}$	4
	HW-38	Washer $\frac{3}{8}$	4
	HNFL-38-16	Flange Lock Nut $\frac{3}{8}$ - 16	4
34	30-034	Right Boom Holder (17-503 & 15-493 Booms Only)	1
	30-035	Left Boom Holder (17-503 & 15-493 Booms Only)	1
35	16-194	Anti-Vortex Fitting	1
36	16-155	Elbow	1
37		Double Thread Fitting (part of tank)	1
38	33-496	Reducer Bushing	1
39	HB-38-16-150	Bolt $\frac{3}{8}$ - 16 x $1\frac{1}{2}$	4
40	18-448	1" ball valve	1

TURBO-QUAD AGITATOR DRAWING

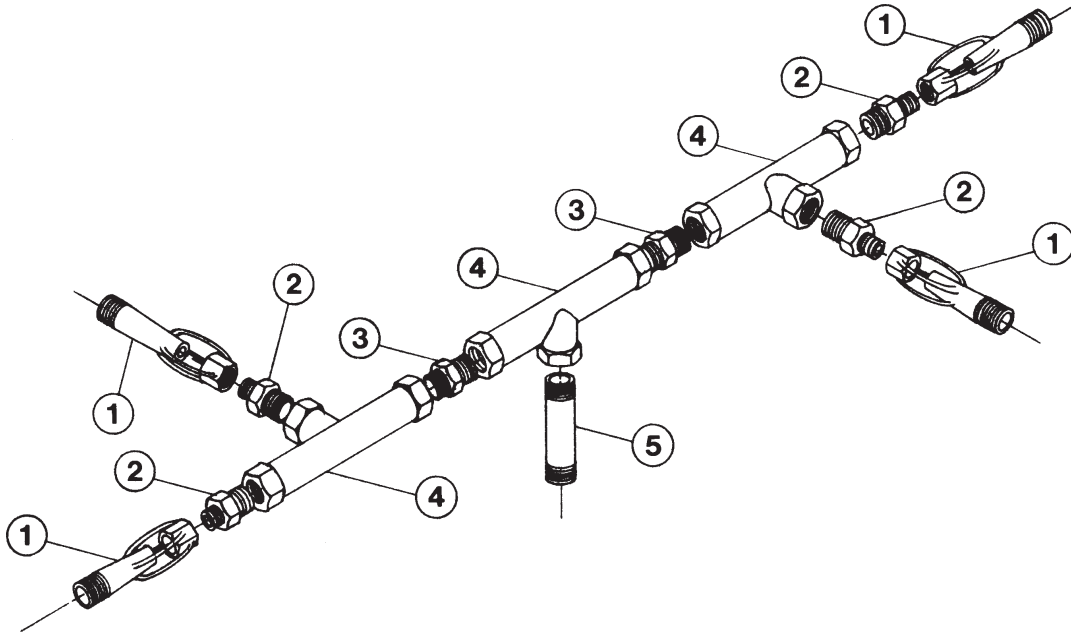

PARTS

TURBO-QUAD AGITATOR PARTS LIST

REF#	PART#	DESCRIPTION	QUANTITY
1	16-036	Agitator Jet (Includes one each $\frac{1}{8}$ " , $\frac{5}{53}$ " , and $\frac{3}{16}$ " orifices)	4
2	16-173	Reducer $\frac{3}{4}$ x $\frac{1}{2}$	4
3	16-158	Close Nipple $\frac{3}{4}$ x $\frac{3}{4}$	2
4	16-157	Female Pipe Thread Tee $\frac{3}{4}$ x $\frac{3}{4}$ x $\frac{3}{4}$	3
5	16-172	Nylon Nipple $\frac{3}{4}$ NPT x $3\frac{1}{2}$	1

15-301 ORBITROL DRAWING

PARTS

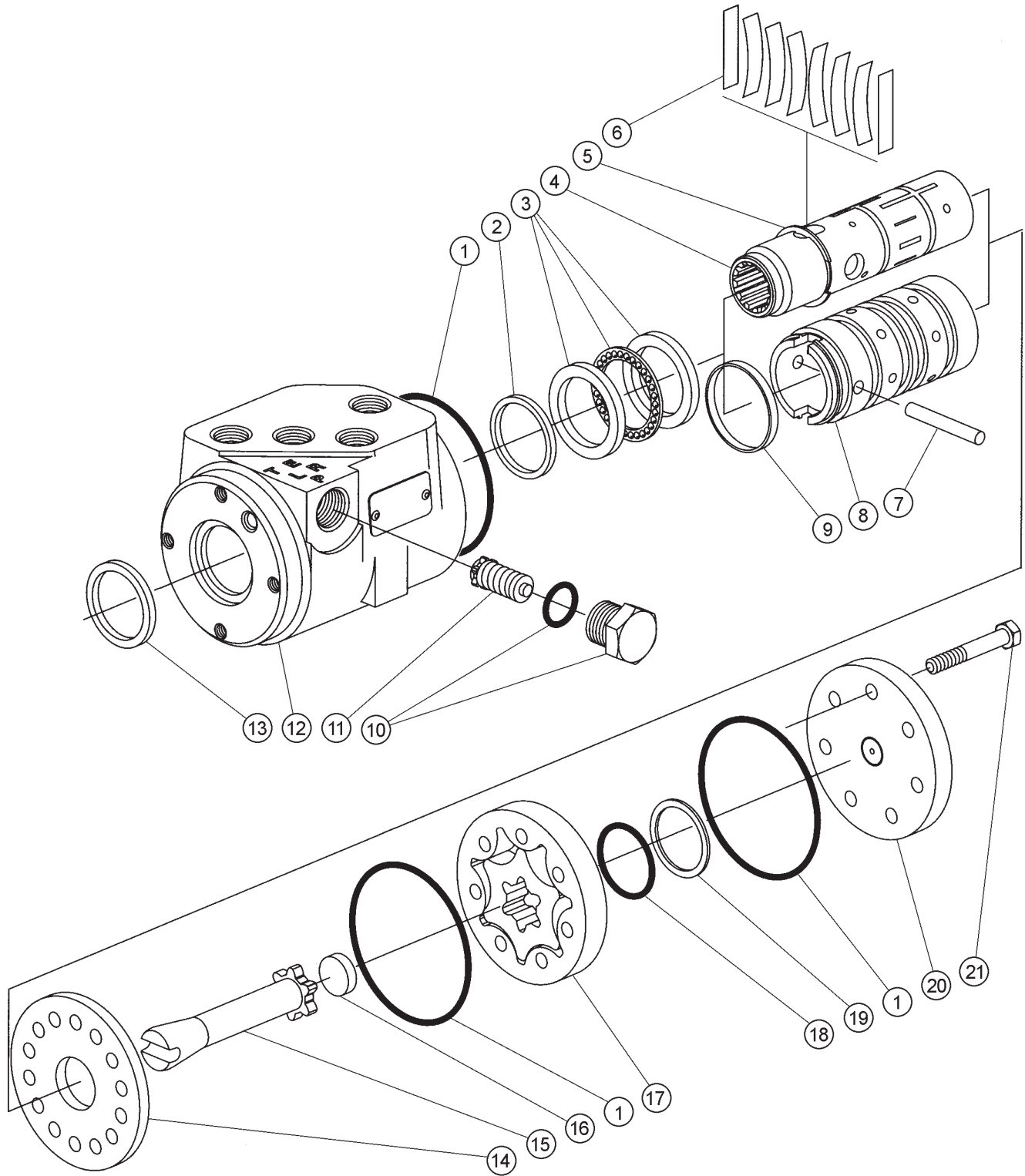

15-301 ORBITROL PARTS LIST

REF #	PART #	DESCRIPTION	QUANTITY
1*		O-Ring Seal	3
2*		Quad Seal	1
3	15-301-14	Bearing Kit	1
		Bearing Race	2
		Bearing	1
4		Spool	1
5	15-301-13	External Retaining Ring	1
6	15-301-15	Spring Centering Kit (Includes Ref# 9)	1
		Spring Spacer	2
		Centering Spring	6
		Spring Retaining Ring	1
7	15-301-08	Pin	1
8		Sleeve	1
9		Retainer	1
10	15-301-11	Plug and O-ring	1
*		O-Ring Seal	1
		Plug	1
11	15-301-12	Relief Valve/Check (1015 psi (70 bar))	1
12		Housing	1
13*		Dust Seal	1
14	15-301-06	Wear Plate	1
15	15-301-07	Drive	1
16	15-301-05	Spacer	1
17	15-301-04	Gerotor	1
18*		O-Ring	1
19*		Seal	1
20	15-301-03	End Cap	1
21	15-301-02	Cap Screw	7
*	15-301-01	Seal Kit	

15-301 ORBITROL SPECIFICATIONS

Maximum System Pressure	1015 psi (70 bar)
Maximum Back Pressure	150 psi (10 bar)
Maximum System Operating Temperature.	200°F (93°C)
Maximum Flow	4 gpm (15 lpm)
Maximum Temperature Differential between Steering Unit and System.	50°F (28°C)
Input Torque Powered	15-25 lb/in @ 100 psi tank pressure (2-3 Nm @ 7 bar)
Input Torque Maximum Non-powered	60 lb/ft (81 Nm)
Rotation Limits	None
Fluid	SAE 10W-40 API Service SJ or higher Motor Oil
Check Valve for Manual Steering	Yes
Relief Valve Setting	1015 psi (70 bar)
Ports	9/16" - 18 SAE O-Ring 4 Ports
Displacement	61 cu. in/ R (100 cu cm/R)

16-998 HYPRO[®] PUMP DRAWING

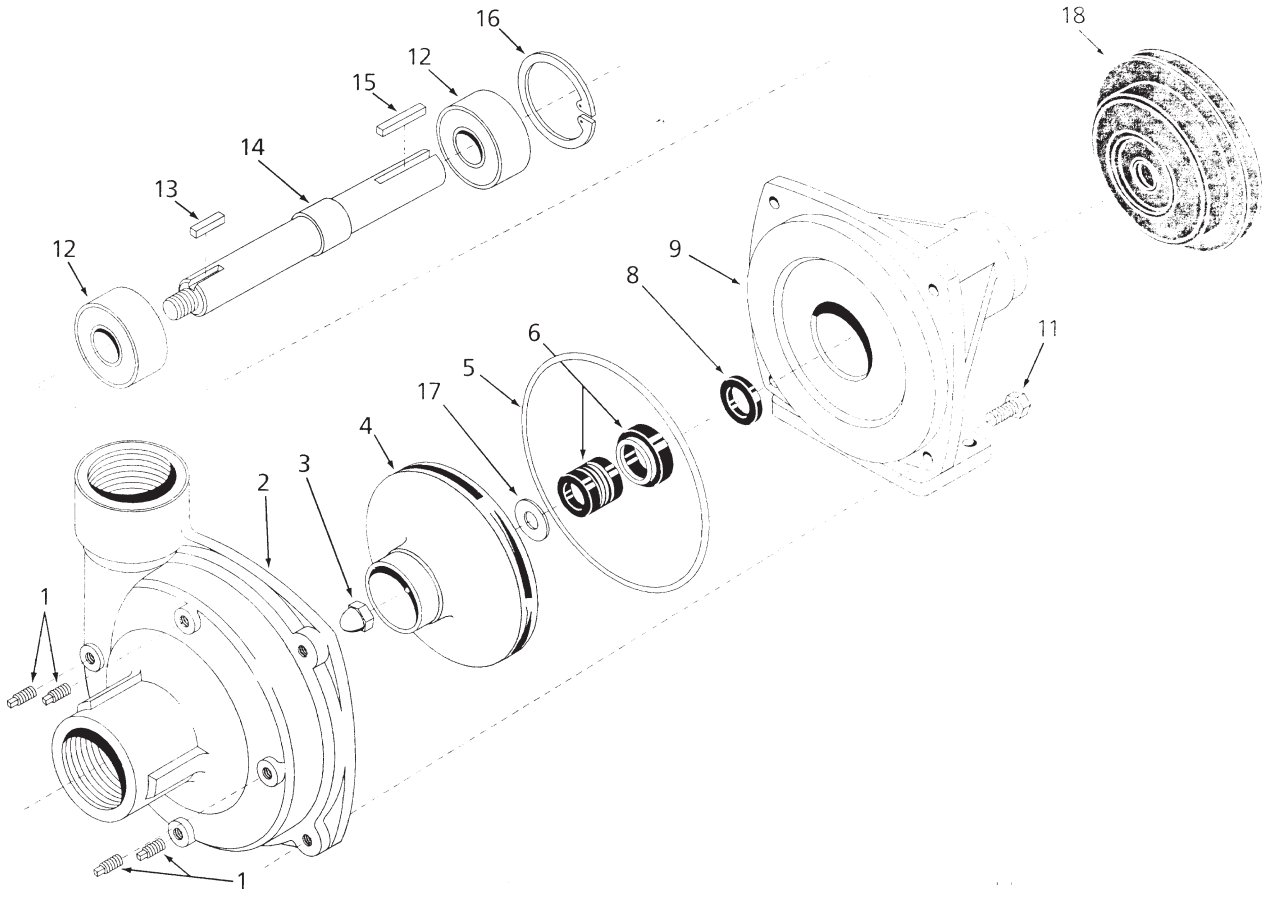

PARTS

16-998 HYPRO® PUMP PARTS LIST

REF#	PART#	DESCRIPTION	QUANTITY
1	16-998-01	Drain Plug	4
2	16-998-02	Pump Casing	1
3	16-998-03	Impeller Nut	1
4	16-966-16	Impeller	1
5*	16-467	O-ring	1
6*	16-998-05	Mechanical Seal (Silicon Carbide)	1
8*	16-966-06	Slinger Ring	1
9	16-998-06	Mounting Flange	1
11	16-998-07	Bolt	4
12	16-966-10	Ball Bearing	2
13	16-998-08	Key	1
14	16-998-09	Pump Shaft	1
15	16-822-20	Key	1
16	16-966-13	Bearing Retainer	1
17*	16-998-10	Gasket	1
18	16-994-01	Clutch	1
	16-998-12	Pump Only	
*	16-967	Silicone - Carbon Seal Kit	

NOTE:

When servicing the spray pump or filter, all control valves must be shut off if there is liquid in the tank.

30-102 EATON PUMP DRAWING

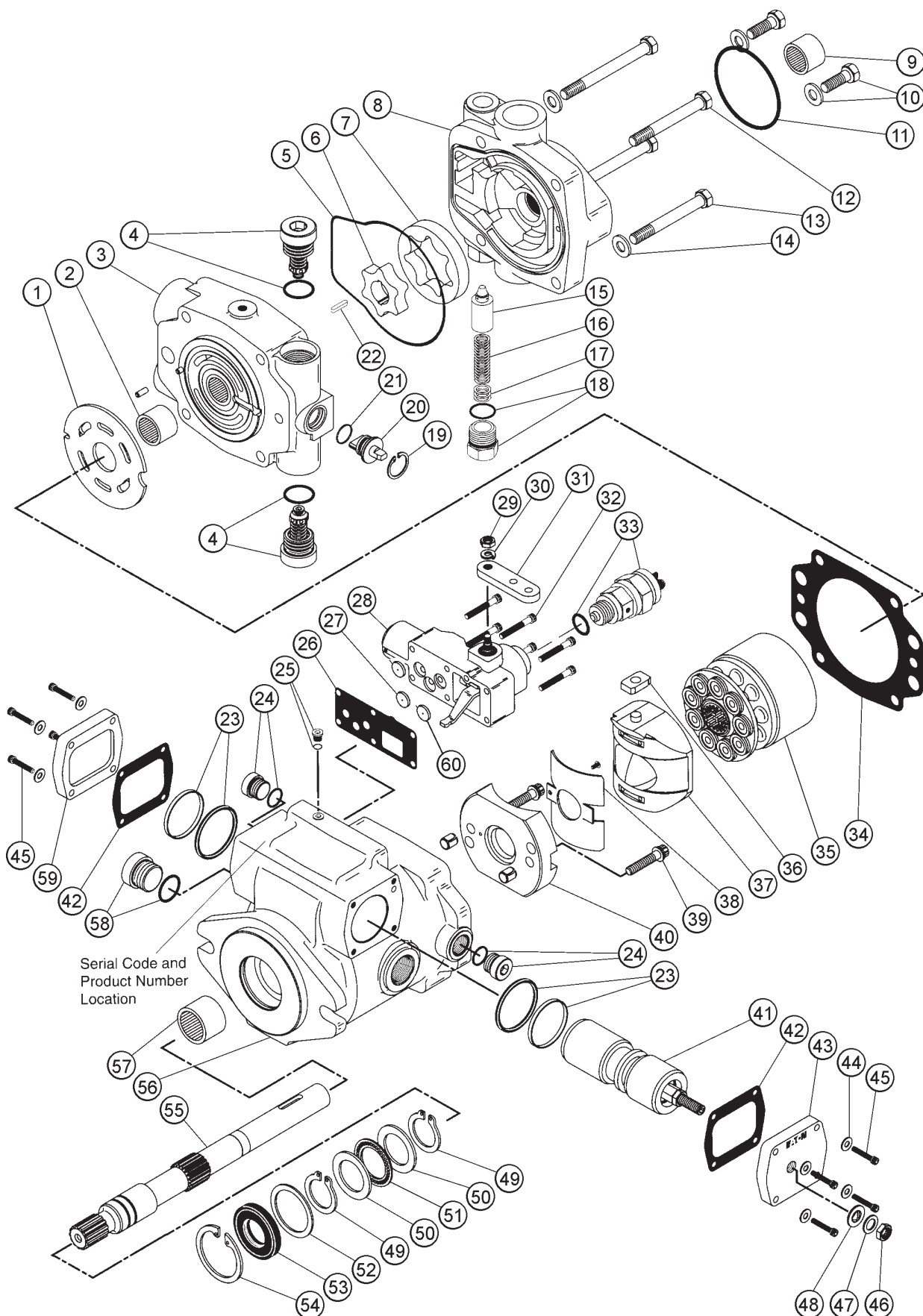

Serial Code and
Product Number
Location

PARTS

30-102 EATON PUMP PARTS LIST

REF#	PART#	DESCRIPTION	QUANTITY
1	33-058-16	Valve Plate (CW Rotation)	1
2	33-058-26	Bearing (Press Fit)	1
3	33-058-25	Back Plate Assembly	1
4	33-058-12	Relief Valve S/A	2
*		O-Ring	2
5*		Molded O-Ring	1
6	33-058-38	Inner Ring Gerotor	1
7	33-058-39	Outer Ring Gerotor	1
8	33-058-35	Charge Pump Adapter Assembly	1
9	33-058-46	Bearing (Press Fit)	1
10		Bolt and Washer	2
11*		O-Ring	1
12	33-058-14	Cap Screw $\frac{3}{8}$ - 16 x 4	2
13	33-058-13	Cap Screw $\frac{3}{8}$ - 16 x $3\frac{1}{2}$	2
14	33-058-44	Washer	4
15	33-058-50	Poppet	1
16	33-058-49	Spring	1
17	33-058-48	Shims	As Required
18	33-058-47	Plug	1
*		O-Ring	1
19*		Retaining Ring	1
20	33-058-41	Dump Valve Actuator	1
21*		Quad-Ring	1
22	33-058-34	Key	1
23*		Seal Sub-Assembly	2
24	33-058-32	Plug S/A	2
*		O-Ring	2
25	33-058-19	Plug Sub-Assembly	1
*		O-Ring	1
26*		Control Housing Gasket	1
27	33-058-40	Control Valve Orifice	1
28	33-058-37	Servo Control Assembly	1
29	33-058-29	Nut	1
30	33-058-30	Lockwasher	1
31	33-058-36	Control Arm	1
32	33-058-15	Cap Screw	6
33	33-058-45	Interlock Switch	1
34*		Housing Gasket	1
35	33-058-04	Rotating Kit Assembly	1
36	33-058-06	Servo Piston Follower	1
37	33-058-09	Cam Plate S/A	1
38	33-058-22	Bushing	1
39	33-058-24	Cap Screw	2
40	33-058-20	Cradle Sub-Assembly	1
41	33-058-05	Servo Piston Assembly	1
42*		Cover Plate Gasket	2
43	33-058-08	Cover Plate	1
44	33-058-43	Washer	8
*	33-058-01	Seal Repair Kit	

(Continued on next page)

30-102 EATON PUMP DRAWING

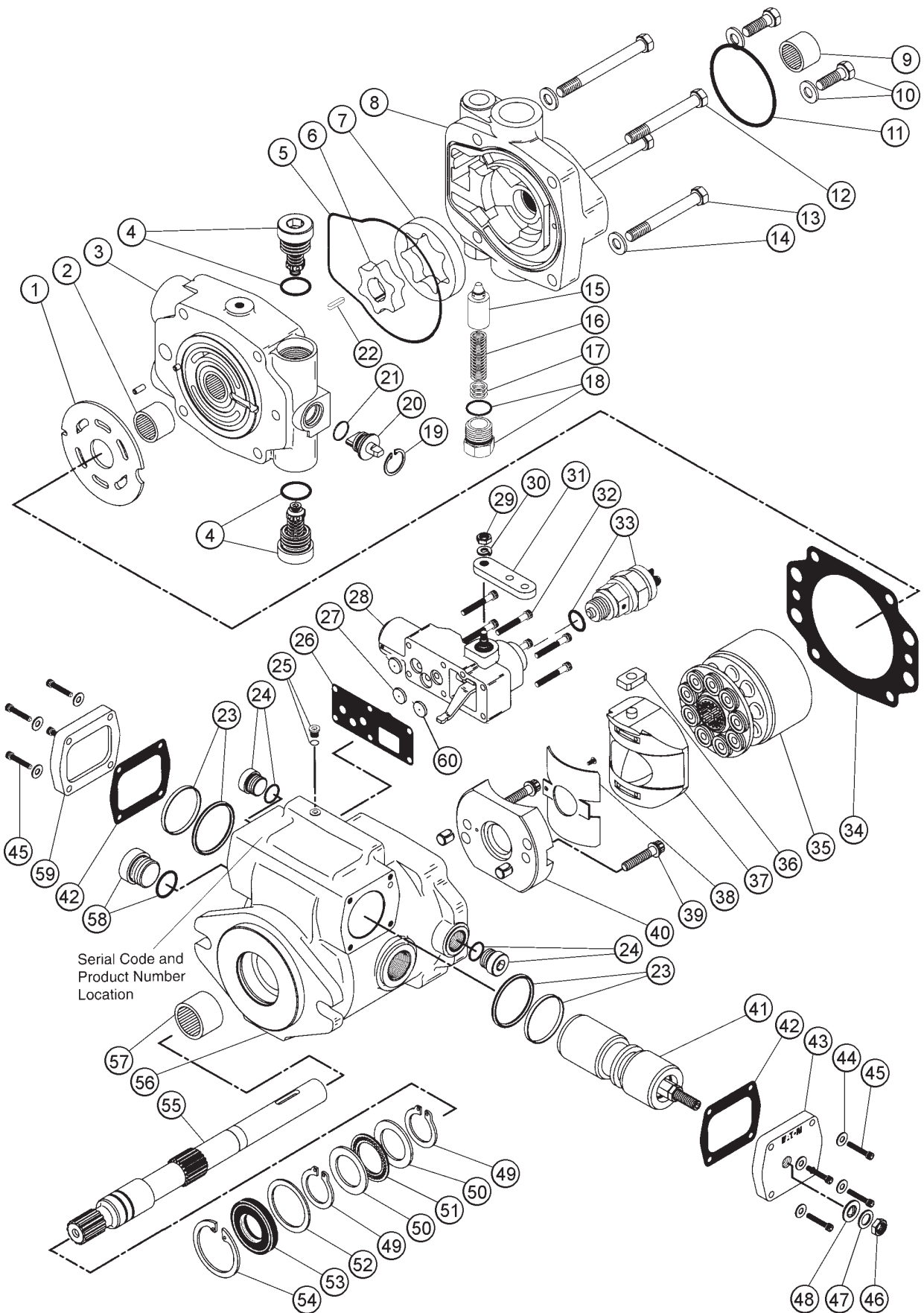

Serial Code and
Product Number
Location

PARTS

30-102 EATON PUMP PARTS LIST

REF#	PART#	DESCRIPTION	QUANTITY
45	33-058-03	Cap Screw #10 - 24 x 1	8
46	33-058-02	Jam Nut	1
47	33-058-42	Washer	1
48*		Seal Washer	1
49*		Retaining Ring	2
50	33-058-10	Thrust Race	2
51	33-058-11	Thrust Bearing	1
52	33-058-31	Washer	1
53*	33-058-52	Shaft Seal	1
54*		Retaining Ring	1
55	33-058-28	Drive Shaft	1
56	33-058-17	Housing Assembly	1
57	33-058-18	Bearing (Press Fit)	1
58	33-058-33	Plug S/A	1
*		O-Ring	1
59	33-058-07	Cover Plate	1
60	33-058-51	Control Valve Orifice	2
*	33-058-01	Seal Repair Kit	

30-101 EATON MOTOR DRAWING

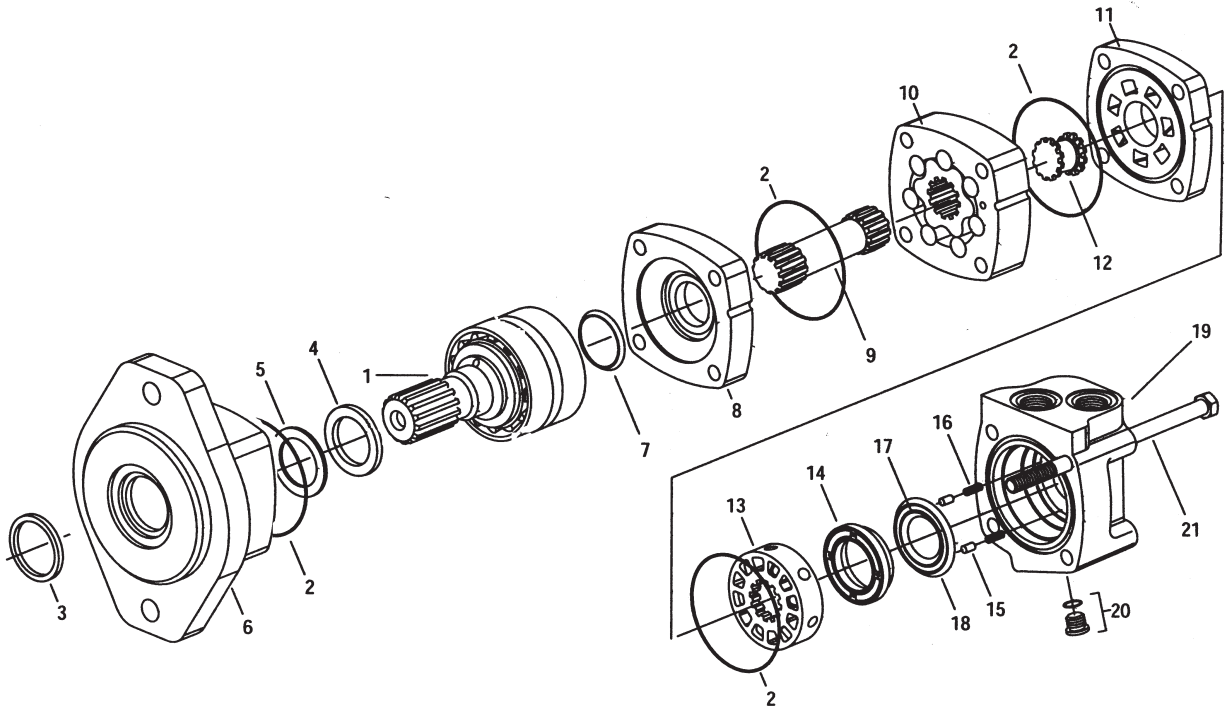

PARTS

30-101 EATON MOTOR PARTS LIST

REF#	PART#	DESCRIPTION	QUANTITY
1	30-101-01	Shaft and Bearing Kit (7/8 splined 13T)	1
2*		Seal	4
3*		Exclusion Seal	1
4*		Shaft Seal	1
5*		Back Up Ring	1
6	30-101-02	Bearing Housing	1
7*		Shaft Face Seal	1
8	30-101-03	Wear Plate	1
9	30-101-04	Main Drive	1
10	30-101-05	Geroler	1
11	30-101-06	Valve Plate	1
12	14-207	Valve Drive	1
13	14-208	Valve	1
14	30-101-07	Balance Ring	1
15	14-210	Balance Ring Pin	2
16	14-209	Compression Spring	2
17*		Inner Face Seal	1
18*		Outer Face Seal	1
19	30-101-08	Valve Housing	1
20	30-101-09	Plug Assembly	1
*		O-ring	1
21	30-101-10	Cap Screw	4
* 	30-101-11	Seal Kit	1 per

3182 PLUMBING DRAWING (RAVEN 440)

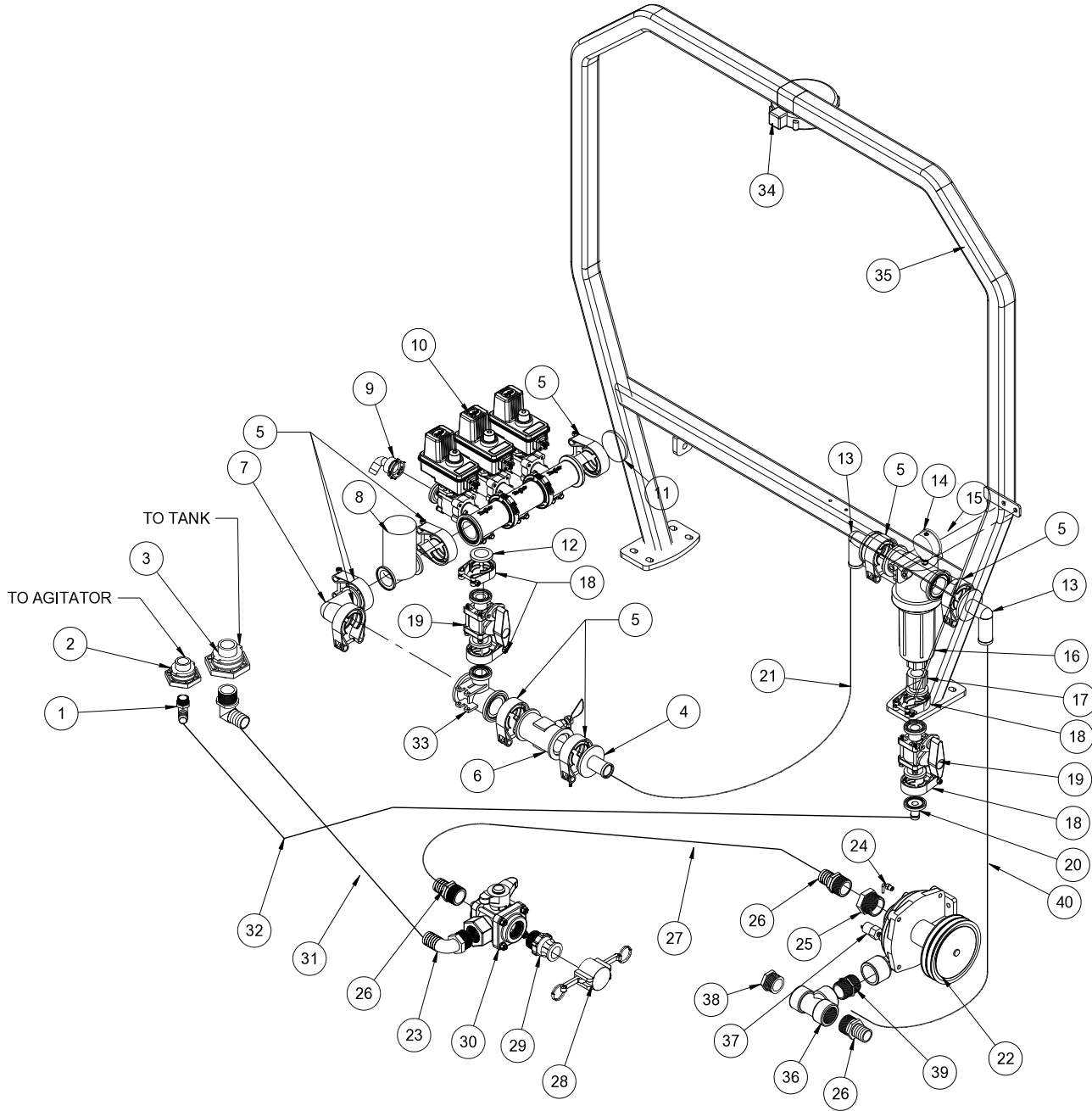

Accessories

3182 PLUMBING PARTS LIST (RAVEN 440)

REF#	PART#	DESCRIPTION	QUANTITY
1	16-155	Elbow	1
2	16-150	Double Threaded Fitting	1
3	16-194	Anti-Vortex Fitting	1
4	15-744	#75 1 ¹ / ₄ Hose Barb	1
5	15-741	#75 Series Clamp	8
6	18-373	Flow Meter	1
	18-373-01	Sensor	1
7	15-734	#75 Elbow Coupling	1
8	16-524	Motorized Control Valve	1
9	15-553	³ / ₄ - 90° Hose Barb	3
	15-553-01	Clip	3
	15-553-02	O-ring	3
	8887-132	³ / ₄ " Orange PVC Hose 132" (left boom)	1
	8887-90	³ / ₄ " Orange PVC Hose 90" (center boom)	1
	8887-124	³ / ₄ " Orange PVC Hose 124" (right boom)	1
	18-040	Hose Clamps	6
10	15-743	Manifold Valve	1
11	15-742	#75 Inlet Cover	1
12	15-778	Blank Gauge Port Flange	1
13	15-739	#75 x 90° x 1 ¹ / ₂ Hose Barb	2
14	16-281	Liquid Filled Gauge	1
15	HB-38-16-500	Bolt ³ / ₈ - 16 x 5	2
	HNFL-38-16	Flange Lock Nut ³ / ₈ - 16	2
16	15-737	Flanged Strainer	1
	16-968-03	Screen (50 mesh)	1
17	15-735	#50 x 1 Female Pipe thread Fitting	1
18	15-740	#50 Series Clamp	4
19	15-738	Flanged Ball Valve	2
20	15-808	#50 x 1 Straight Hose Barb	1
21	8897-60	1 ¹ / ₄ " Discharge Hose 60"	1
	18-116	Hose Clamp	2
22	16-998	Hypro Spray Pump	1
23	16-156	Elbow	2
24	33-494	Male Elbow	1
25	16-825	Hex Bushing	1
26	16-161	Fitting	3
27	8897-36	1 ¹ / ₄ " Discharge Hose 36"	1
	18-116	Hose Clamp	2
28	16-935	Quick Coupler Cap	1
29	16-180	Quick Coupler Male	1
30	18-372	3-Way Valve	1
	18-372-01	Handle	1
31	8897-23	1 ¹ / ₄ " Discharge Hose 23"	1
	18-116	Hose Clamp	2
32	8896-60	1" Discharge Hose 60"	1
	18-222	Hose Clamp	2
33	15-775	Reducer Tee	1
34	10-408-01	Phoenix 10 GPS	1
35	31-063	ROPs	1
36	18-390	Tee	1
37	33-480	Pressure Switch	1
38	10-389	Plug	1
39	16-880	Nipple	1
40	8897-48	1 ¹ / ₄ " Discharge Hose 48"	1
	18-116	Hose Clamp	2

3184 PLUMBING DRAWING (RAVEN 203)

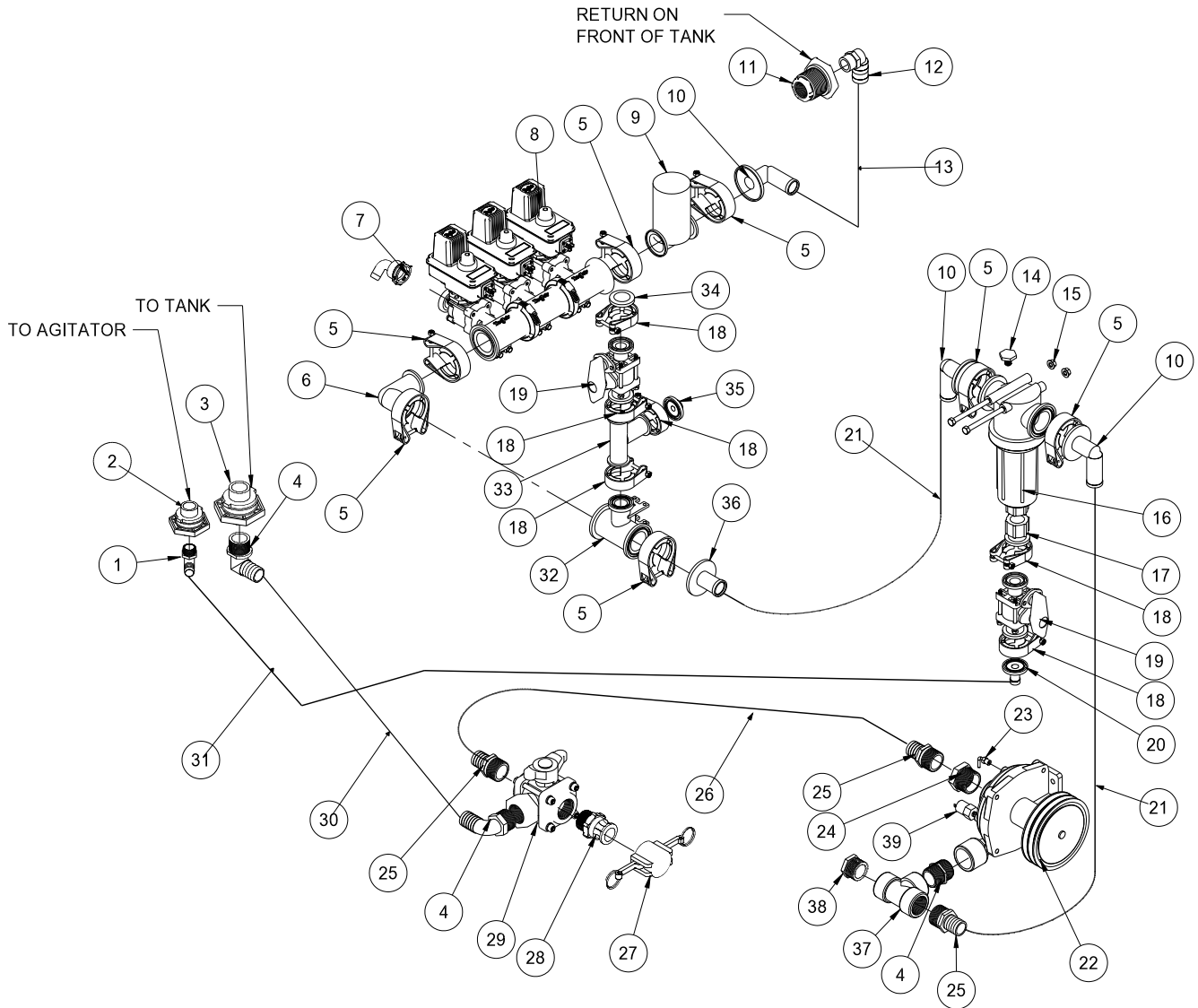

Accessories

3184 PLUMBING PARTS LIST (RAVEN 203)

REF#	PART#	DESCRIPTION	QUANTITY
1	16-155	Elbow	1
2	16-150	Double Threaded Fitting	1
3	16-194	Anti-Vortex Fitting	1
4	16-880	Nipple	3
5	15-741	#75 Series Clamp	7
6	15-734	#75 Elbow Coupling	1
7	15-553	$\frac{3}{4}$ " - 90° Hose Barb	3
	15-553-01	Clip	3
	15-553-02	O-ring	3
	8887-120	$\frac{3}{4}$ " Orange PVC Hose 120"	3
	18-040	Hose Clamps	6
8	15-743	Manifold Valve	1
9	16-524	Motorized Control Valve	1
10	15-739	#75 x 90° x $1\frac{1}{2}$ " Hose Barb	3
11	16-945	Double Threaded Fitting	1
12	15-779	Hose Barb	1
13	8897-44	$1\frac{1}{4}$ " Discharge Hose 44"	1
	18-116	Hose Clamp	2
14	15-780	$\frac{1}{4}$ " Poly Hex Plug	1
15	HB-38-16-500	Bolt $\frac{3}{8}$ " - 16 x 5	2
	HNFL-38-16	Flange Lock Nut $\frac{3}{8}$ " - 16	2
16	15-737	Flanged Strainer	1
	16-968-03	Screen (50 mesh)	1
17	15-735	#50 x 1 Female Pipe thread Fitting	1
18	15-740	#50 Series Clamp	4
19	15-738	Flanged Ball Valve	2
20	15-808	#50 x 1 Straight Hose Barb	1
21	8897-60	$1\frac{1}{4}$ " Discharge Hose 60"	2
	9021-65	Fire Sleeve	2
	18-116	Hose Clamp	4
22	16-998	Hypro Spray Pump	1
23	33-494	Male Elbow	1
	8954-30	Clear Hose	1
24	16-825	Hex Bushing	1
25	16-161	Fitting	3
26	8897-24	$1\frac{1}{4}$ " Discharge Hose 24"	1
	18-116	Hose Clamp	2
27	16-935	Quick Coupler Cap	1
28	16-180	Quick Coupler Male	1
29	18-372	3-Way Valve	1
	18-372-01	Handle	1
30	8897-36	$1\frac{1}{4}$ " Discharge Hose 36"	1
	18-116	Hose Clamp	2
31	8896-66	1" Discharge Hose 55"	1
	18-222	Hose Clamp	2
32	15-775	Reducer Tee	1
33	15-776	#50 Series Tee	1
34	15-778	Blank Gauge Port Flange	1
35	15-777	Gauge Port Flange	1
36	15-744	#75 $1\frac{1}{4}$ " Hose Barb	1
37	18-390	Tee	1
38	10-389	Plug	1
39	33-480	Pressure Switch	1

3185/3186 PLUMBING DRAWING (ENVIZIO PRO II + SHARP SHOOTER)

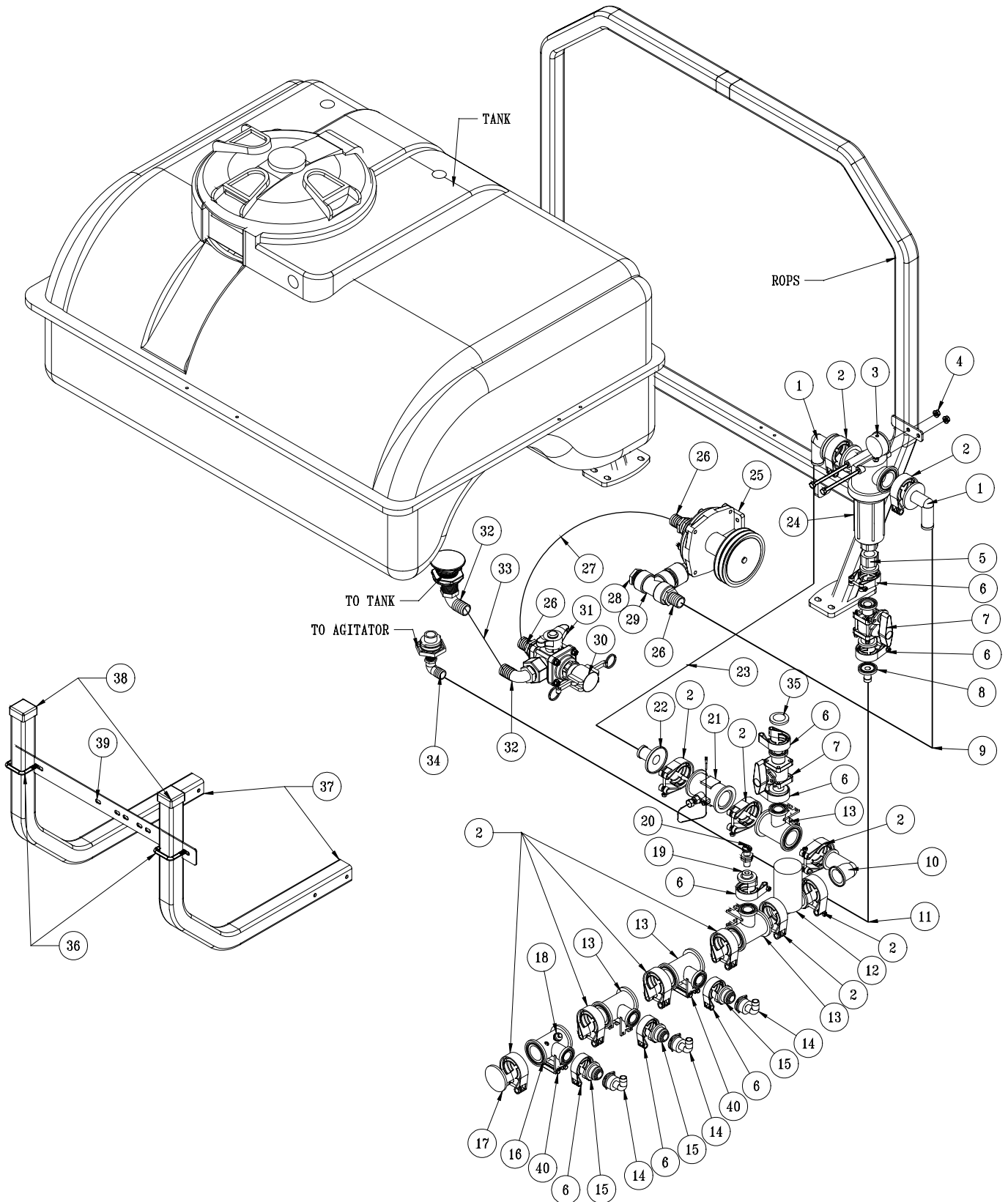

Accessories

3185/3186 PLUMBING PARTS LIST (ENVIZIO PRO II + SHARP SHOOTER)

REF#	PART#	DESCRIPTION	QUANTITY
1	15-739	#75 90° Hose Barb	2
2	15-741	#75 Series Clamp	11
3	16-281	Liquid Filled Gauge	1
4	HB-38-16-550	Bolt $\frac{3}{8}$ - 16 x $5\frac{1}{2}$	2
	HNFL-38-16	Flange Lock Nut $\frac{3}{8}$ - 16	2
5	15-735	#50 x 1 FTP Fitting	1
6	15-740	#50 Series Clamp	8
7	15-738	Flanged Ball Valve	2
8	15-808	Flanged Hose Barb, Straight	1
9	8897-46	1 $\frac{1}{4}$ " Discharge Hose x 46"	1
	18-116	Hose Clamp	2
10	15-734	#75 Elbow Coupling	1
11	8896-60	1" Discharge Hose x 60"	1
	18-222	Hose Clamp	2
12	16-524	Motorized Control Valve	1
13	15-775	Reducer Tee	4
14	15-553	$\frac{3}{4}$ - 90° Hose Barb	3
	8887-124	$\frac{3}{4}$ " Orange PVC Hose x 124" (Right Boom)	1
	8887-90	$\frac{3}{4}$ " Orange PVC Hose x 90" (Center Boom)	1
	8887-132	$\frac{3}{4}$ " Orange PVC Hose x 132" (Left Boom)	1
	18-040	Hose Clamp	6
15	15-825	QC Flange Adapter	3
16	30-164	Tapped Reducer Tee	1
17	15-742	#75 Inlet Cover	1
18	30-168-04	SharpShooter Presser Sensor Assembly	1
19	15-777	Gauge Port Flange	1
20	30-177	Envizio Pro II® Pressure Transducer	1
21	18-373	Flow Meter	1
	18-373-01	Sensor	1
22	15-744	#75 Hose Barb	1
23	8897-60	1 $\frac{1}{4}$ " Discharge Hose x 60"	1
	18-116	Hose Clamp	2
24	15-737	Flanged Strainer	1
	16-968-05	Screen (80 mesh)	1
25	16-998	Hypro® Pump	1
26	16-161	Fitting	3
27	8897-36	Discharge Hose	1
	18-116	Hose Clamp	2
28	10-389	Plug	1
29	18-390	Pipe Tee	1
30	16-935	Quick Coupler Cap	1
	16-180	Quick Coupler Male	1
31	18-372	3-Way Valve	1
32	16-156	Elbow	2
33	8897-24	1 $\frac{1}{4}$ " Discharge Hose x 24"	1
	18-116	Hose Clamp	2
34	16-155	Elbow	1
35	15-778	Blank Gauge Port Flange	1
36	17-537	Square U-bolt	2
37	30-163	SharpShooter Boom Support	2
38	16-557	Square Cap	2
39	30-167	Mounting Strap	1
40	15-743-03	Mounting Rail	2
	15-743-06	SS Screw	8

3187/3188 PLUMBING DRAWING (RAVEN 400 + SHARPSHOOTER)

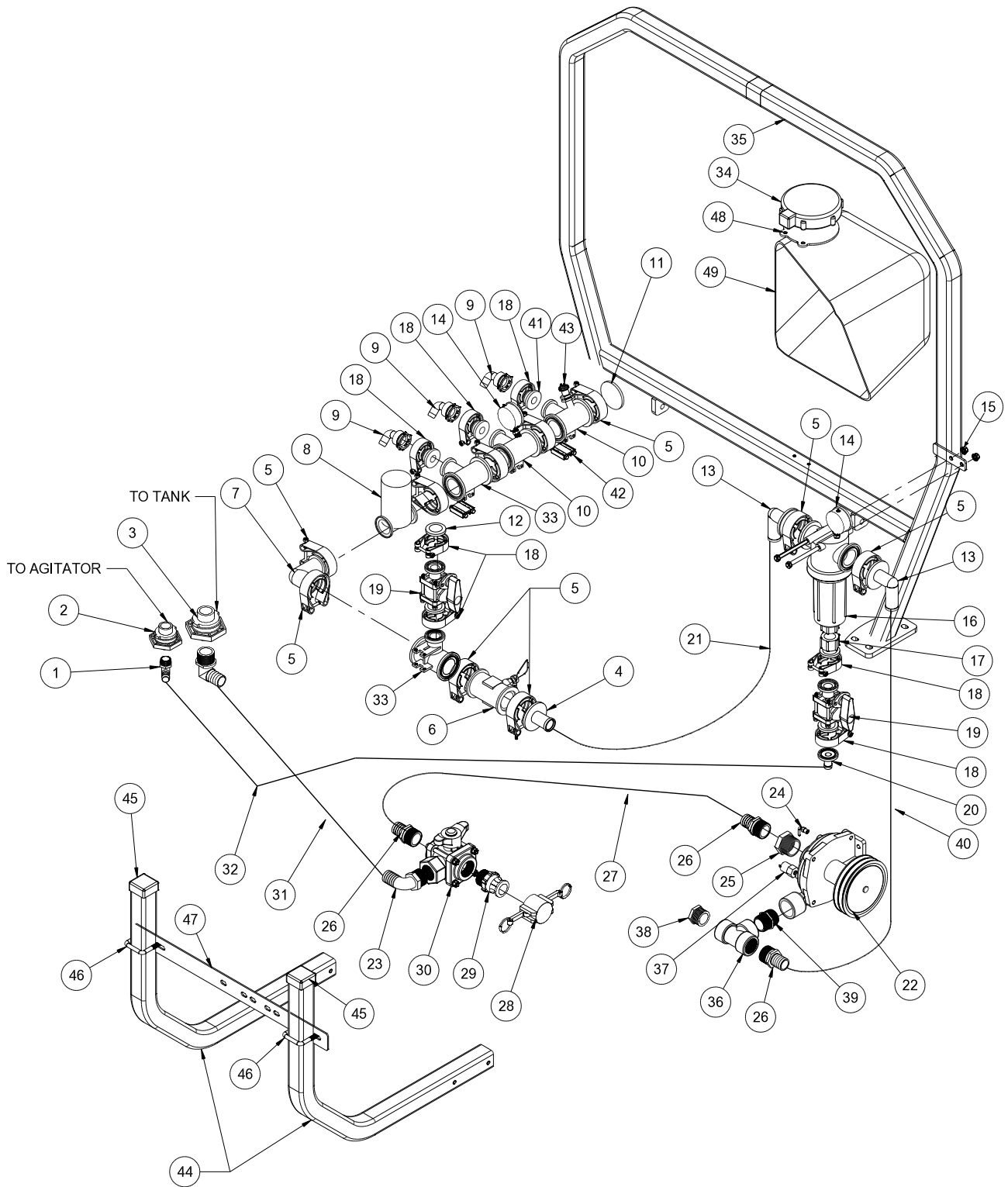

Accessories

3187/3188 PLUMBING PARTS LIST (RAVEN 440 + SHARPSHOOTER)

REF#	PART#	DESCRIPTION	QUANTITY
1	16-155	Elbow	1
2	16-150	Double Threaded Fitting	1
3	16-194	Anti-Vortex Fitting	1
4	15-744	#75 1 ¹ / ₄ Hose Barb	1
5	15-741	#75 Series Clamp	10
6	18-373	Flow Meter	1
	18-373-01	Sensor	1
7	15-734	#75 Elbow Coupling	1
8	16-524	Motorized Control Valve	1
9	15-553	³ / ₄ - 90° Hose Barb	3
	15-553-01	Clip	3
	15-553-02	O-ring	3
	8887-132	³ / ₄ " Orange PVC Hose 132" (left boom)	1
	8887-90	³ / ₄ " Orange PVC Hose 90" (center boom)	1
	8887-124	³ / ₄ " Orange PVC Hose 124" (right boom)	1
	18-040	Hose Clamps	6
10	30-164	Tapped Reducer Tee	2
11	15-742	#75 Inlet Cover	1
12	15-778	Blank Gauge Port Flange	1
13	15-739	#75 x 90° x 1 ¹ / ₂ Hose Barb	2
14	16-281	Liquid Filled Gauge	2
15	HB-38-16-550	Bolt ³ / ₈ - 16 x 5 ¹ / ₂	2
	HNFL-38-16	Flange Lock Nut ³ / ₈ - 16	2
16	15-737	Flanged Strainer	1
	16-968-05	Screen (80 mesh)	1
17	15-735	#50 x 1 Female Pipe thread Fitting	1
18	15-740	#50 Series Clamp	7
19	15-738	Flanged Ball Valve	2
20	15-808	#50 x 1 Straight Hose Barb	1
21	8897-60	1 ¹ / ₄ " Discharge Hose 60"	1
	18-116	Hose Clamp	2
22	16-998	Hypro Spray Pump	1
23	16-156	Elbow	2
24	33-494	Male Elbow	1
25	16-825	Hex Bushing	1
26	16-161	Fitting	3
27	8897-36	1 ¹ / ₄ " Discharge Hose 36"	1
	18-116	Hose Clamp	2
28	16-935	Quick Coupler Cap	1
29	16-180	Quick Coupler Male	1
30	18-372	3-Way Valve	1
	18-372-01	Handle	1
31	8897-24	1 ¹ / ₄ " Discharge Hose 24"	1
	18-116	Hose Clamp	2
32	8896-60	1" Discharge Hose 60"	1
	18-222	Hose Clamp	2
33	15-775	Reducer Tee	2
34	10-408-01	Phoenix 10 GPS	1
35	31-063	ROPs	1
36	18-390	Tee	1
37	33-480	Pressure Switch	1

(continued on next page)

3187/3188 PLUMBING DRAWING (RAVEN 400 + SHARPSHOOTER)

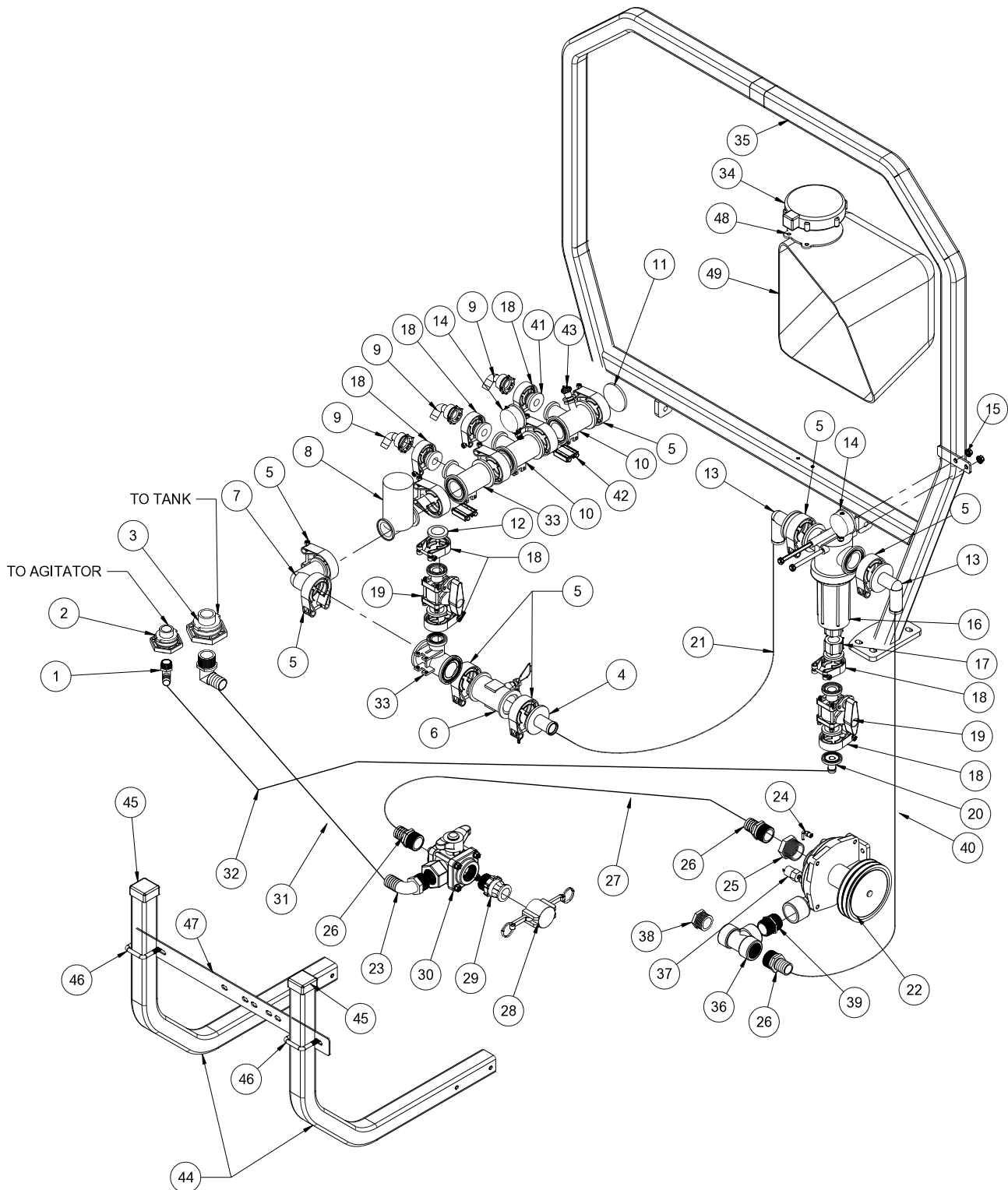

3187/3188 PLUMBING PARTS LIST (RAVEN 440 + SHARPSHOOTER)

REF#	PART#	DESCRIPTION	QUANTITY
38	10-389	Plug	1
39	16-880	Nipple	1
40	8897-46	1 ¹ / ₄ " Discharge Hose 46"	1
	18-116	Hose Clamp	2
41	15-825	QC Flange Adapter	3
42	15-743-03	Mounting Rail	2
	15-743-06	SS Screws	8
43	30-168-04	SharpShooter Pressure Sensor	1
44	30-163	SharpShooter Boom Support	2
45	16-557	Square Cap	2
46	17-537	Square U-bolt	2
47	30-167	Mounting Strap	1
48	30-173	GPS Plate	1
49	30-172	Fiberglass Cover	1

CONTROLS 3182 SYSTEM DRAWING (RAVEN 440)

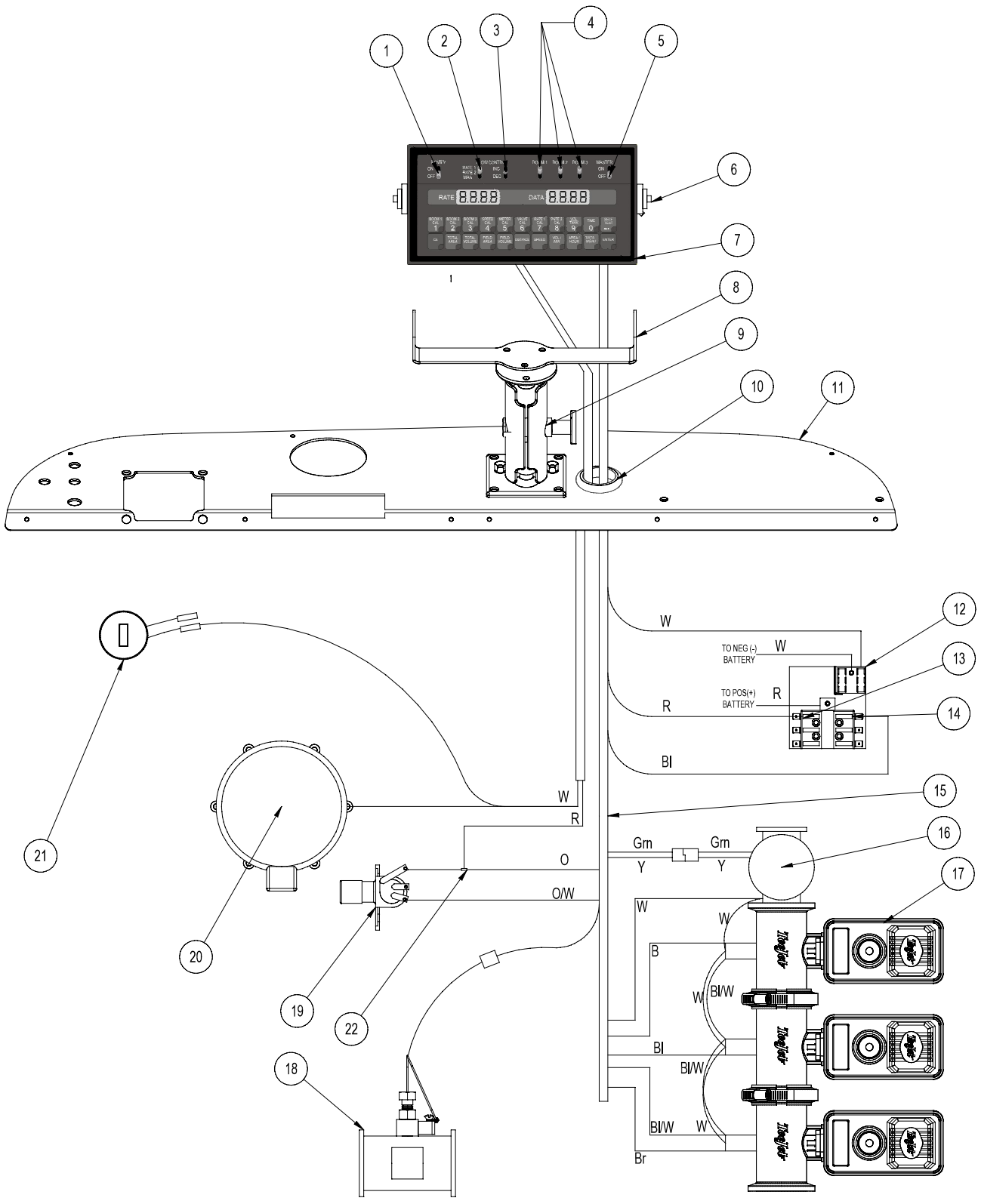

Accessories

CONTROLS 3182 SYSTEM PARTS LIST

REF#	PART#	DESCRIPTION	QUANTITY
1	16-140	Power Switch	1
2	16-525-01	Rate1/Rate2 Manual Switch	1
3	16-873	Adjustment Switch	1
4	16-141	Boom Switch	3
5	16-697	Master Switch	1
6	16-558	Mounting Knob	2
7	16-525	Console (only)	1
	16-234	Console Cover	1
8	20-557	440 Console Mount	1
9	20-540	Ram Mount	1
10	50-400	Grommet	1
11	20-596	Dash Board	1
12	33-271	Fuse Block	1
13	33-508	Auto Blade Type Fuse 15 amp	1
14	33-562	Auto Blade Type Fuse 40 amp	1
15	15-369	Console Control Cable	1
16	16-524	Motorized Control Valve	1
17	15-743	Manifold Valve	1
18	18-373	Flow Meter	1
19	33-509	Master Boom Floor Switch	1
20	10-408-01	Phoenix 10 GPS	1
21	12-017	Hour Meter	1

Use Dielectric Grease On All Electrical Connections

CONTROLS 3184 SYSTEM DRAWING (RAVEN 203)

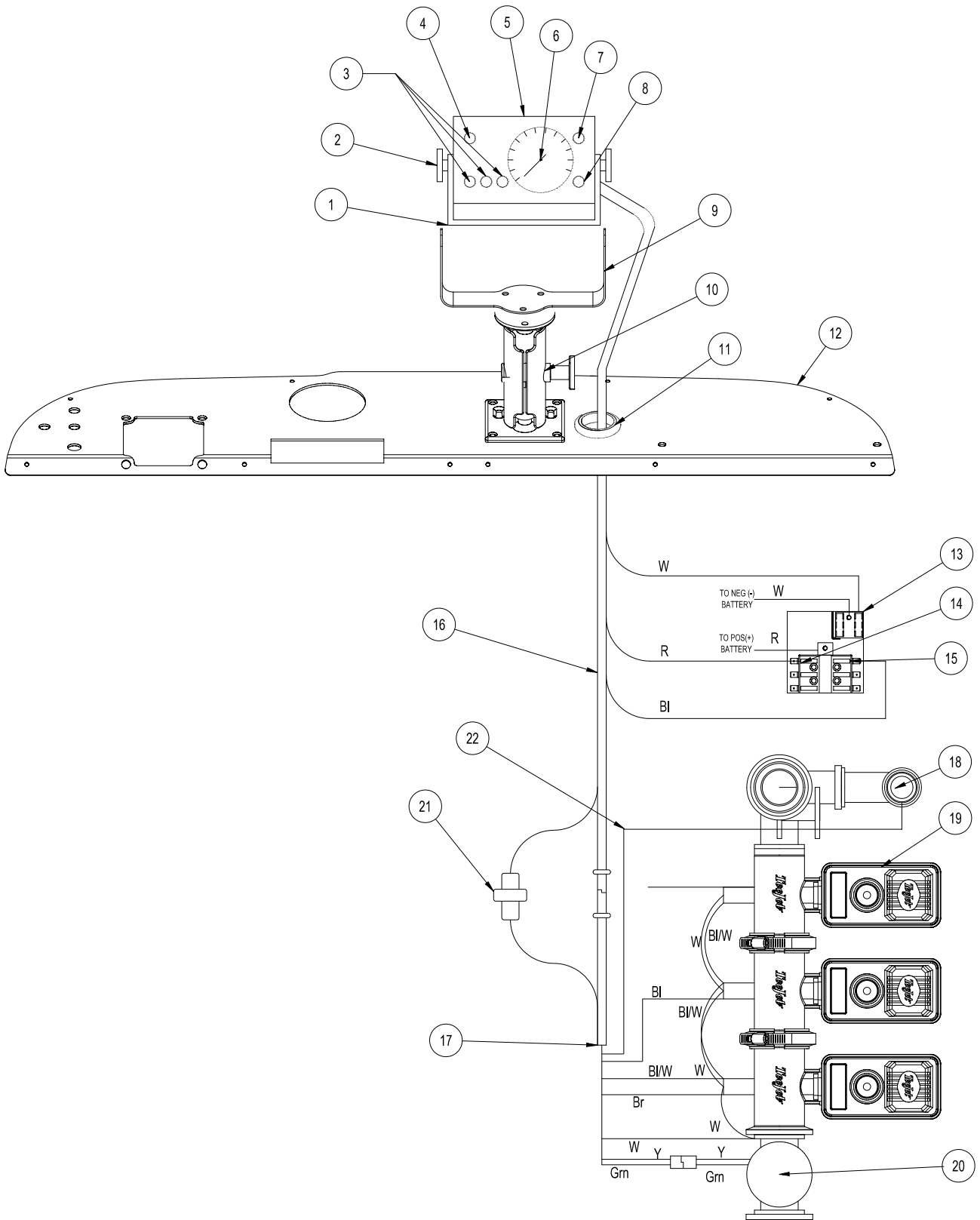

Accessories

CONTROLS 3184 SYSTEM PARTS LIST (RAVEN 203)

REF#	PART#	DESCRIPTION	QUANTITY
1	16-958-01	Mounting Bracket	1
3	16-898	Boom Switch	3
2	16-900	Mounting Knob	2
4	16-899	Master Switch	1
5	18-418	Console with Liquid Filled Pressure Gauge	1
6	33-090-02	Liquid Filled Pressure Gauge	1
	33-090-04	Pressure Gauge Tube Fitting	1
7	16-958-02	Fuse Holder	1
	16-525-03	Fuse 15 AMP	1
8	16-895	Pressure Switch	1
9	20-546	Console Mount	1
10	20-540	Ram Mount	1
11	50-400	Grommet	1
12	20-596	Dash Board	1
13	33-271	Fuse Block	1
14	33-508	Auto Blade Type Fuse 15 amp	1
15	33-562	Auto Blade Type Fuse 40 Amp	1
16	16-958-04	Cable Assembly 8ft Enclosure Hook-Up	1
17	16-902	Cable Assembly 72" Solenoid Hook-Up	1
18	15-776	Tee	1
19	15-743	Manifold Valve	1
20	16-524	Motorized Control Valve	1
21	16-958-05	Union Fitting	1
22	16-955	Tubing	1
23	10-225	Wire Harness (fuse block to electric valve)	1

Use Dielectric Grease On All Electrical Connections

WIRING 3185/3186 SYSTEM (ENVIZIO PRO II + SHARP SHOOTER)

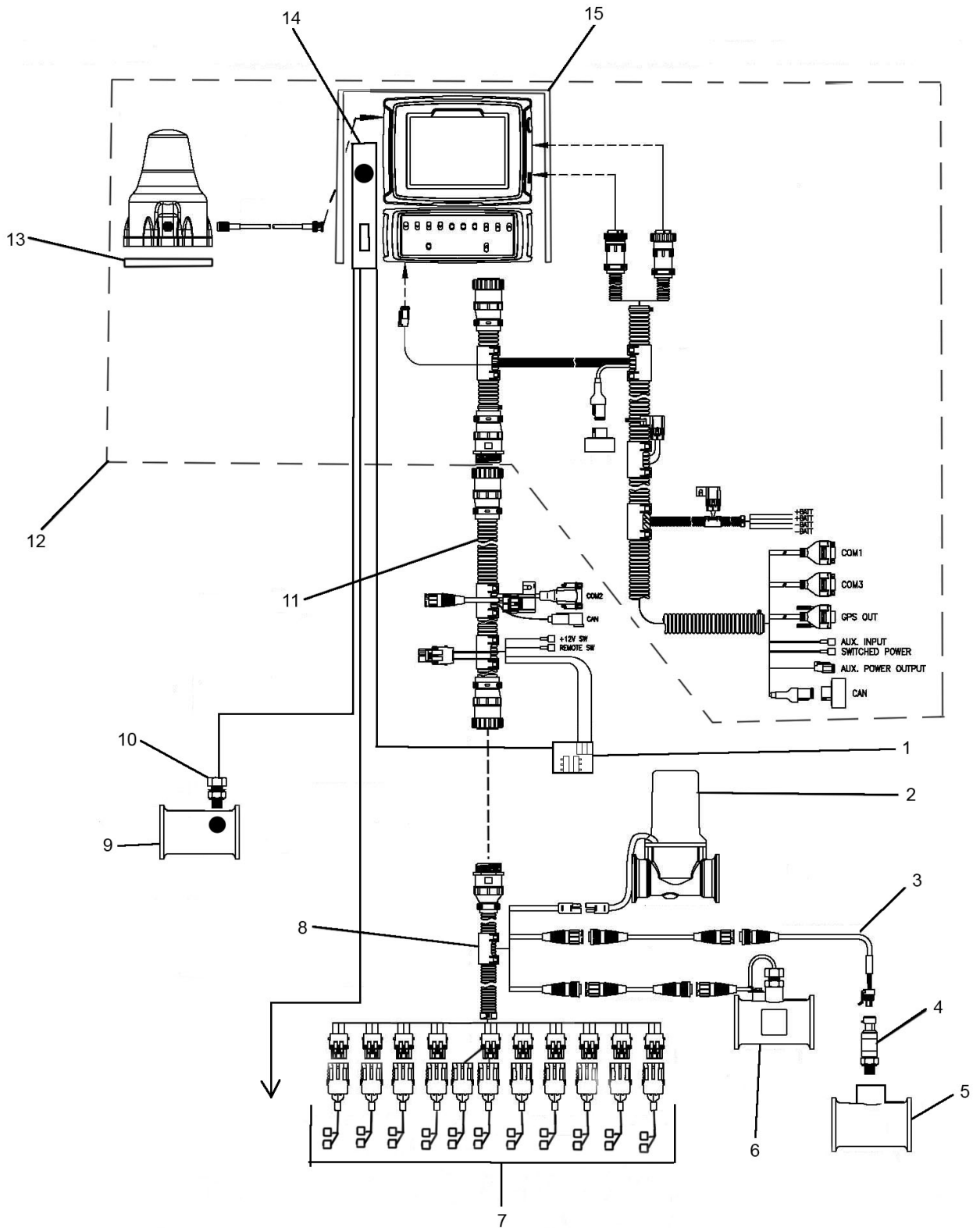

WIRING 3185/3186 SYSTEM (ENVIZIO PRO II + SHARP SHOOTER)

REF#	PART#	DESCRIPTION	QUANTITY
1	33-271	Fuse Block	1
	33-508	Auto Blade Type Fuse 15Amp	2
	33-273	Auto Blade Type Fuse 30Amp	1
	9035	Blade Fuse 1AMP	1
2	16-524	Motorized Control Valve	1
3	30-178	6' Cable for Transducer	1
4	30-177	Pressure Transducer	1
5	15-775	Tee	1
6	18-373	Flow Meter	1
7	30-168	11 Nozzle SharpShooter Turf System for 18' Boom	1
	30-189	12 Nozzle SharpShooter Turf System for 20' Boom	1
8	30-174	12' Product Cable	1
9	30-164	Tapped Reducer Tee	1
10	30-168-04	SharpShooter Pressure Sensor	1
11	30-176	3' Console Cable	1
12	30-171	Envizio Pro Switch Kit	1
13	30-173	GPS Plate	1
14	30-168-01	SharpShooter Power Hub	1
15	30-172	Fiberglass Cover	1
	8803-48	Trim 48"	1
	18-134	Grommet	1
	20-540	Ram Mount	1

Use Dielectric Grease On All Electrical Connections

WIRING 3187/3188 SYSTEM (RAVEN 440 + SHARP SHOOTER)

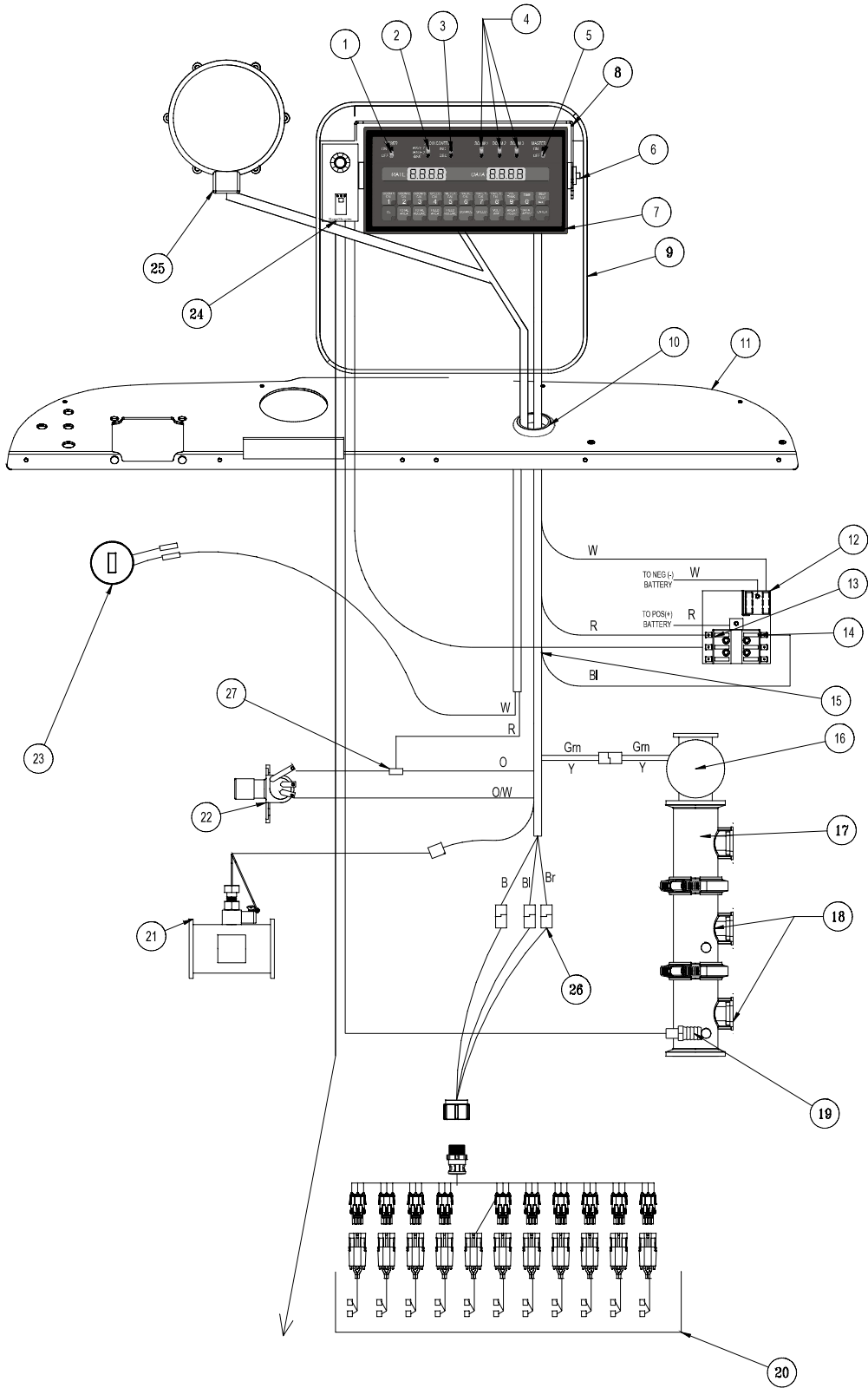

Accessories

WIRING 3187/3188 SYSTEM (RAVEN 440 + SHARP SHOOTER)

REF#	PART#	DESCRIPTION	QUANTITY
1	16-140	Power Switch	1
2	16-525-01	Rate1/Rate2 Manual Switch	1
3	16-873	Adjustment Switch	1
4	16-141	Boom Switch	3
5	16-697	Master Switch	1
6	16-558	Mounting Knob	2
7	16-525	Console (only)	1
8	20-601	440 Console Mount	1
9	30-172	Fiberglass Cover	1
	8803-48	Trim-48"	1
	18-134	Grommet ⁵ / ₈	1
10	50-400	Grommet	1
11	20-596	Dash Board	1
12	33-271	Fuse Block	1
	9035	Blade Fuse 1amp	1
13	33-508	Auto Blade Type Fuse 15 amp	2
14	33-273	Auto Blade Type Fuse 30 amp	1
15	15-369	Console Control Cable	1
16	16-524	Motorized Control Valve	1
17	15-775	Reducer Tee	1
18	30-164	Tapped Reducer	2
19	30-168-04	SharpShooter Pressure Sensor	1
20	30-188	SharpShooter 11-Nozzle Turf System for 18' Boom	1
	30-190	SharpShooter 12-Nozzle Turf System for 20' Boom	1
21	18-373	Flow Meter	1
22	33-509	Master Boom Floor Switch	1
23	12-017	Hour Meter	1
24	30-168-01	SharpShooter Power Hub	1
25	10-408-01	Phoenix 10 GPS	1
	30-173	GPS Mount Plate	1
26	20-600	440 Harness Extension	1

Use Dielectric Grease On All Electrical Connections

16-524 MOTORIZED CONTROL VALVE DRAWING

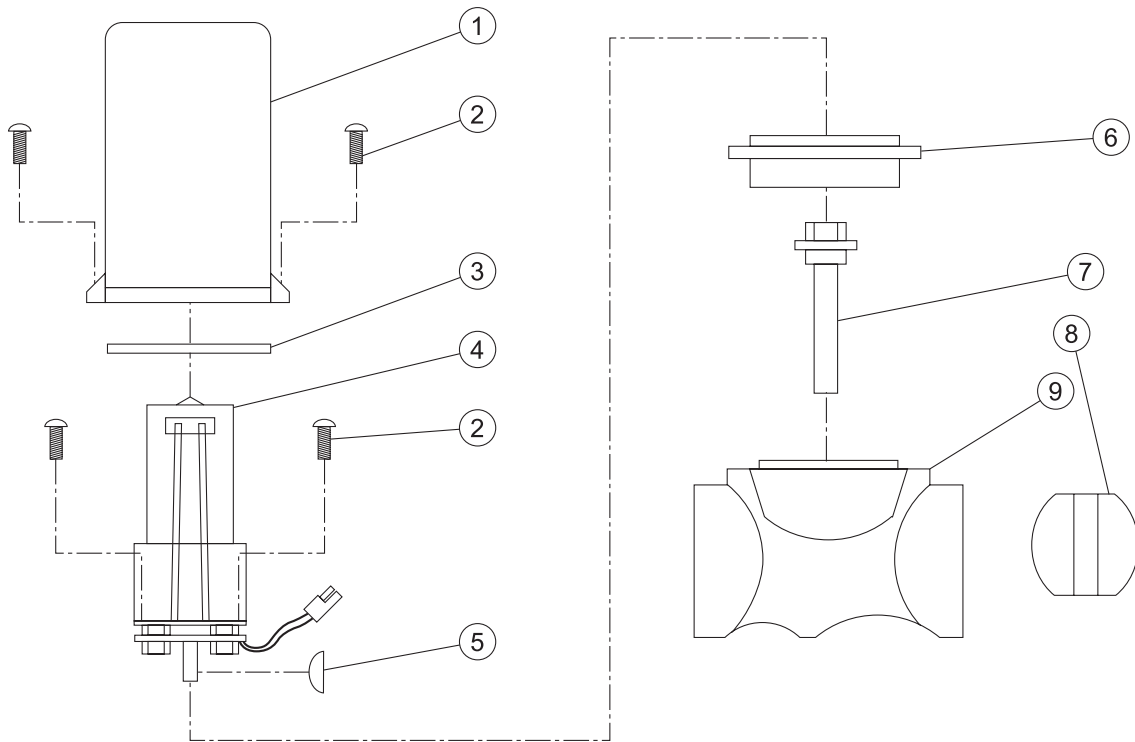

REF#	PART#	DESCRIPTION	QUANTITY
1	16-870	Valve Cover	1
2*	16-524-01	#6 Self Tapping Screw $\frac{3}{4}$ " Long	6
3	16-897	Tetra Seal	1
4	16-875	Motor Assembly (For 16-524)	1
4	16-866-01	Motor Assembly (For 16-995)	1
5*	16-957	Woodruff Key	1
6*	16-524-04	Isolation Flange Assembly	1
7*	16-524-02	Coupler Shaft	1
8*	16-956	Butterfly	1
9*	16-524-03	Valve Body Assembly	1
*	16-524-05	1" Valve ISO-Body Kit	

WHEN SERVICING VALVE:

Replace valve body with ISO-Body Kit if valve has been leaking internally.

Replace motor assembly if the motor will not run or if the printed circuit board is corroded.

Before reassembling valve, remove the coupler shaft from the valve body. Apply Loctite to coupler shaft and woodruff key. Place the coupler shaft (Ref 7) and the woodruff key (Ref 5) onto the motor shaft. Plug motor into the valve connector coming from Sprayer Control Console. Check that the motor rotates in both directions. Motor must stop when coupler CAM releases printed circuit board switch button.

When reassembling valve, grease both sealing surfaces of coupler shaft. Insert coupler shaft into Iso-flange and be sure seal properly seats on shaft. Install on valve body and apply RTV 738 to mounting holes. Reassemble remaining items as shown in parts diagram on opposite side.

15-737 STRAINER

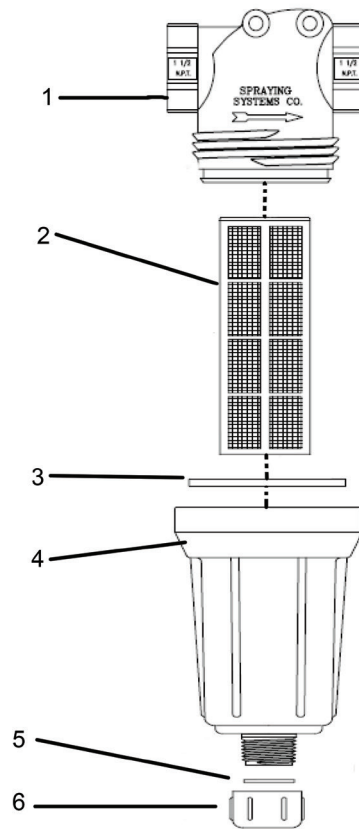

REF#	PART#	DESCRIPTION	QUANTITY
1	15-737-01	Strainer Head 75 Series	1
2	16-968-03	50 Mesh Strainer	1
3	14-521-02	EPDM Gasket	1
4	14-521-03	Bowl 1" NPT	1
5	14-521-04	EPDM Rubber gasket	1
6	14-521-05	Cap	1

15-743 MANIFOLD VALVE DRAWING

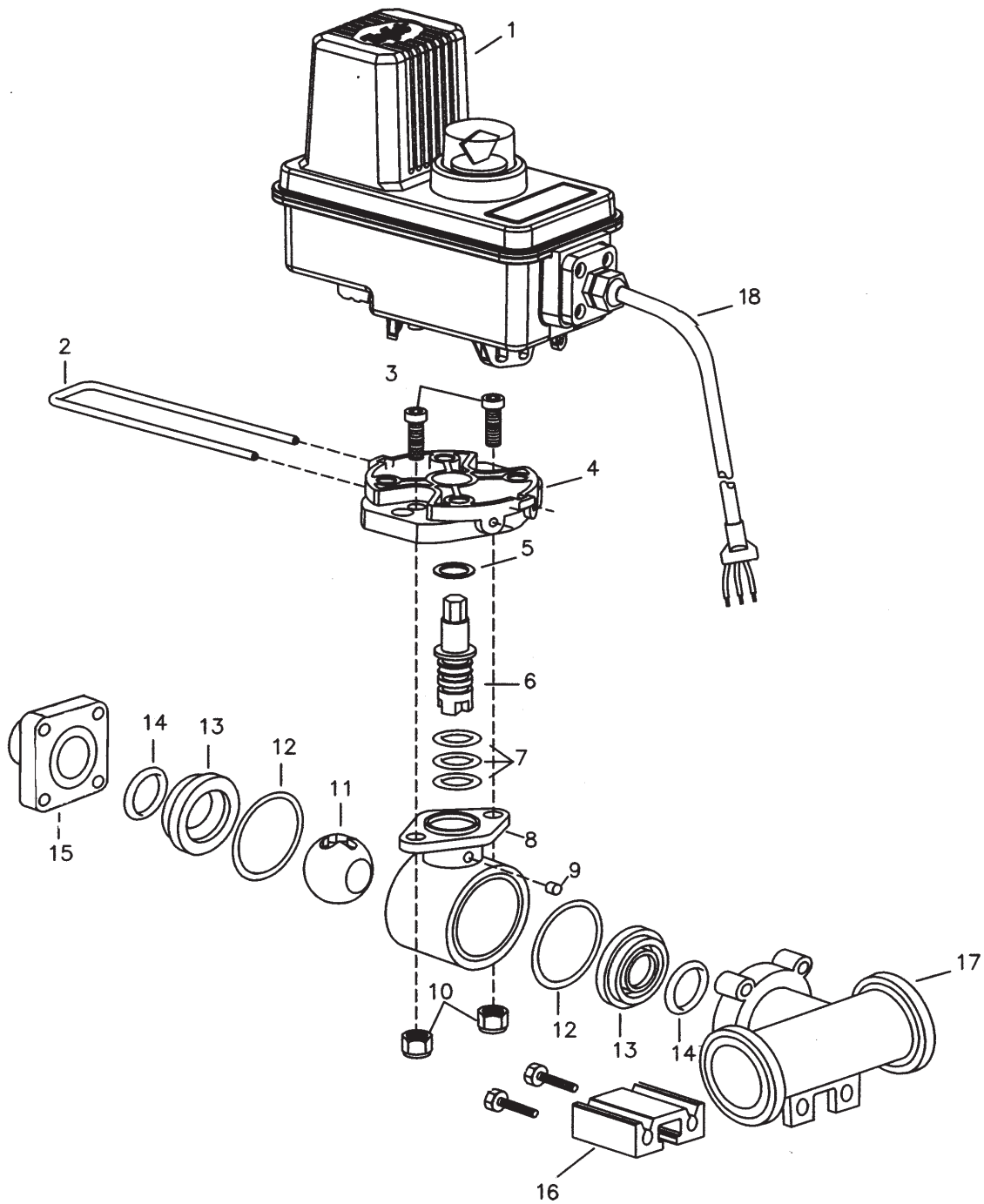

Accessories

15-743 MANIFOLD VALVE PARTS LIST

REF#	PART#	DESCRIPTION	QUANTITY
1	15-552-23	Motor	
2	15-552-24	Retaining Clip	1
3	15-552-25	Socket Head Cap Screw, Stainless Steel	2
4	15-552-26	Motor Adapter, Polypropylene	1
5*	15-517-11	Thrust Washer, Teflon	1
6	15-552-27	Stem, Stainless Steel	1
7*	15-552-05	O-ring, Viton	3
8	15-517-16	Body, Nylon	1
9*	15-517-17	Dust Plug, Felt	1
10		Lock Nut, Stainless Steel	2
11	15-743-04	Ball, Polypropylene	1
12*	15-552-13	Gasket, Viton	2
13*	15-517-19	Seal, teflon	2
14*	15-517-20	O-ring, Viton	2
15	15-743-01	End Cap	1
16	15-743-03	Mounting Rail aluminum	1
17	15-743-02	#75 tee Body	1
*	15-552-10	Spare Parts Kit (includes all * items)	



17-580 20' HEAVY BOOM

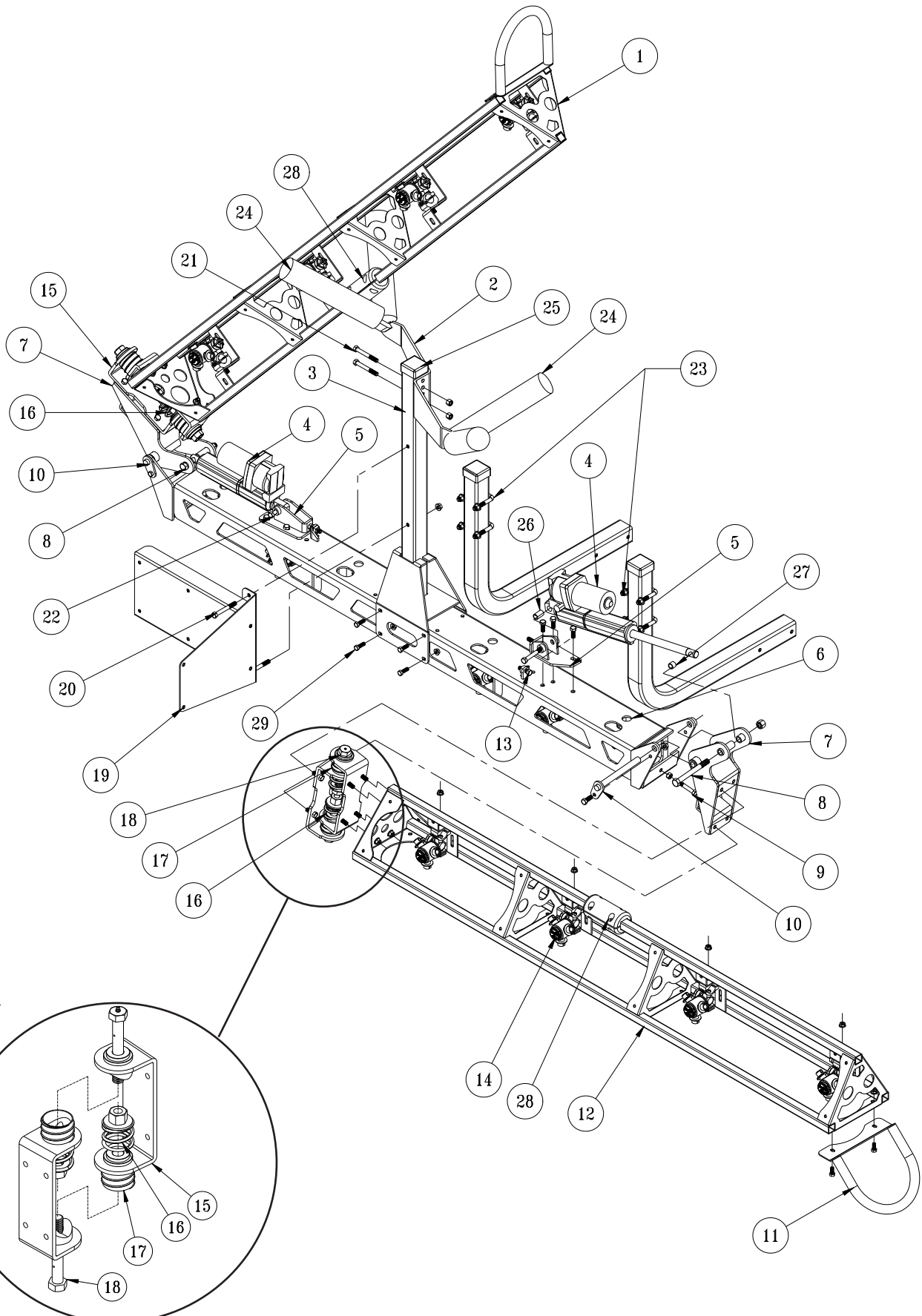

Accessories

17-580 20' HEAVY BOOM

REF#	PART#	DESCRIPTION	QUANTITY
1	17-531	Left Boom Arm	1
2	17-577	V-Boom Nest	1
3	17-578	Boom Nest Post	1
4	30-187	10" Electric Hydraulic Actuator	2
5	30-184	Actuator Mount	2
	HB-38-16-100	Bolt, $\frac{3}{8}$ - 16 x 1	6
	HW-516	Washer, $\frac{5}{16}$	6
	HNFL-38-16	Flange Lock Nut, $\frac{3}{8}$ -16	6
6	17-579	Boom Center	1
7	30-185	Arm Pivot Hinge	2
	76-128	Bushing	4
8	HB-12-13-500	Bolt, $\frac{1}{2}$ - 13 x 5	2
	HNTL-12-13	Lock Nut, $\frac{1}{2}$ - 13	2
9	HB-38-16-150	Bolt, $\frac{3}{8}$ - 16 x $1\frac{1}{2}$	2
	HNFL-38-16	Flange Lock Nut, $\frac{3}{8}$ -16	4
10	17-530	Hinge Pin	2
	HB-516-18-075	Bolt, $\frac{5}{16}$ - 18 x $\frac{3}{4}$	2
11	17-541	Boom End Guard	2
	HBFL-516-18-075	Bolt, $\frac{5}{16}$ - 18 x $\frac{3}{4}$	4
	HNFL-516-18	Flange Lock Nut, $\frac{5}{16}$ - 18	4
12	17-532	Right Boom Arm	1
13	HSSQS-38-16-150	Square Head Set Screw , $\frac{3}{8}$ -16 x $1\frac{1}{2}$	2
14	33-506	Body (see nozzle drawing)	12
	HB-516-18-075	Bolt, $\frac{5}{16}$ -18 x $\frac{3}{4}$	12
	HNFL-516-18	Flange Lock Nut, $\frac{5}{16}$ -18	12
15	17-527	Boom Hinge	4
	HB-38-16-100	Bolt, $\frac{3}{8}$ - 16 x 1	16
	HNFL-38-16	Lock Nut, $\frac{3}{8}$ - 16	16
16	17-539	Compression Spring	4
17	9026-2	Rubber Duct Hose x 2"	4
18	17-540	Tapped Bolt	4
	HW-34	Washer, $\frac{3}{4}$	4
	HNTL-34-10	Lock Nut, $\frac{3}{4}$ -10	4
	HG-14-28-180	Grease Fitting, $\frac{1}{4}$ - 28 x 180°	4
19	17-535	Clean Load Mount	1
20	HB-38-16-300	Bolt, $\frac{3}{8}$ - 16 x 3	2
	HNTL-38-16	Lock Nut, $\frac{3}{8}$ - 16	2
21	HB-38-16-300	Bolt, $\frac{3}{8}$ - 16 x 3	2
	HW-38	Washer, $\frac{3}{8}$	2
	HNTL-38-16	Lock Nut, $\frac{3}{8}$ - 16	2
22	HB-12-13-300	Bolt, $\frac{1}{2}$ - 13 x 3	2
	HNTL-12-13	Lock Nut, $\frac{1}{2}$ - 13	2
23	17-537	Square U-bolt with Nut	4
24	8897-12	$1\frac{1}{4}$ Discharge Hose 12"	4
25	16-557	Square Rubber Cap	1
26	18-036	1" Bushing	2
27	18-234	$\frac{1}{2}$ " Bushing	2
28	17-573	Guide Block	2
	HB-14-20-125	Bol $\frac{1}{4}$ -20 x $1\frac{1}{4}$	8
	HWL-14	Lock Washer $\frac{1}{4}$	8
	HN-14-20	Nut $\frac{1}{4}$ - 20	8
29	HBFL-516-18-075	Bolt, $\frac{5}{16}$ - 18 x $\frac{3}{4}$	4
	HNFL-516-18	Flange Lock Nut, $\frac{5}{16}$ - 18	4

17-525 18' HEAVY BOOM

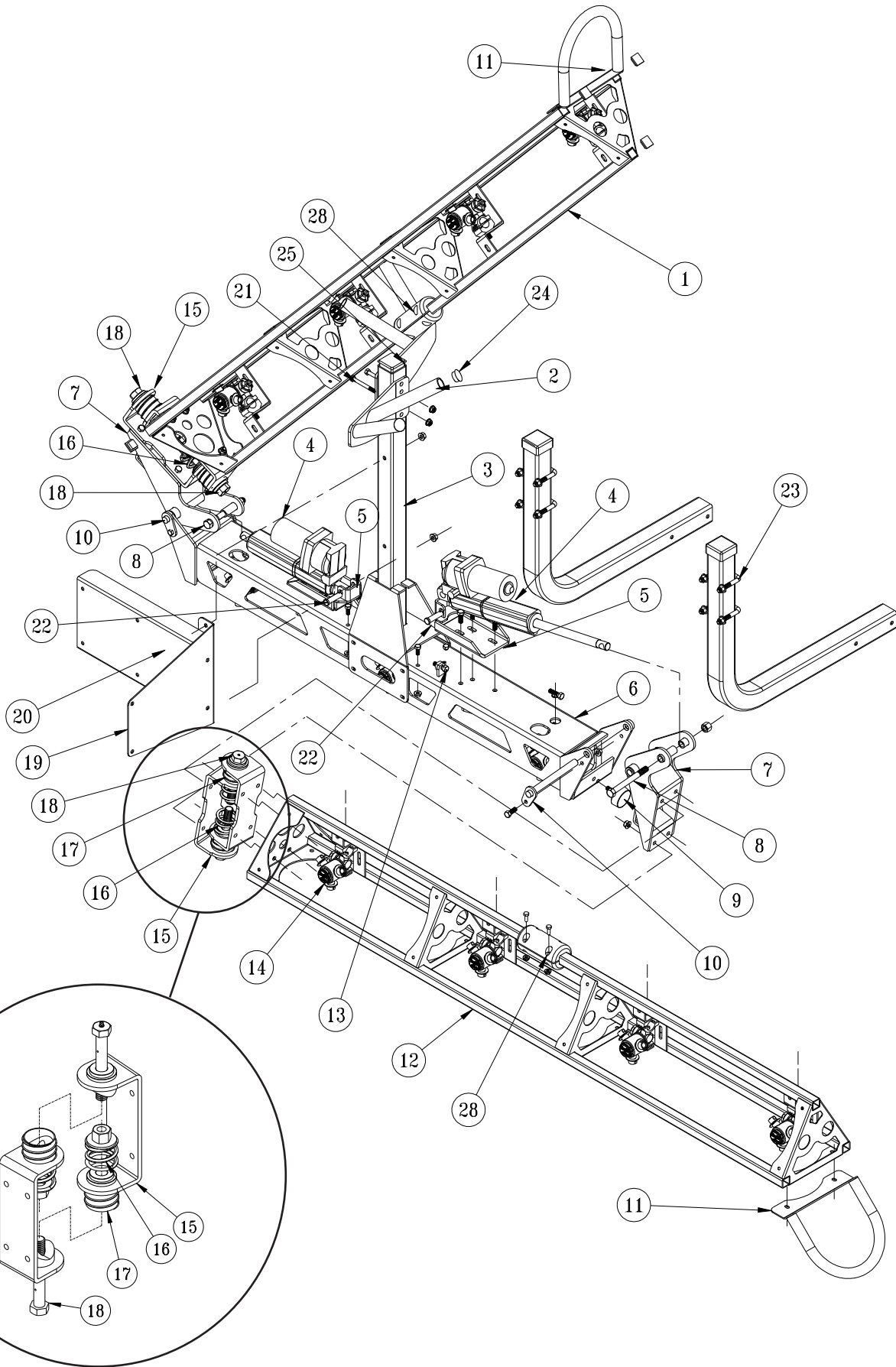

Accessories

17-525 18' HEAVY BOOM

REF#	PART#	DESCRIPTION	QUANTITY
1	17-531	Left Boom Arm	1
2	17-576	V Boom Nest	1
3	17-578	Boom Nest Post	1
	HBFL-516-18-075	Bolt, $\frac{5}{16}$ - 18 x $\frac{3}{4}$	4
	HNFL-516-18	Flange Lock Nut, $\frac{5}{16}$ - 18	4
4	17-553	8" Electric Hydraulic Actuator	2
5	17-545	Ram Mount	2
	HB-38-16-100	Bolt, $\frac{3}{8}$ - 16 x 1	6
	HW-516	Washer, $\frac{5}{16}$	6
	HNFL-38-16	Flange Lock Nut, $\frac{3}{8}$ -16	6
6	17-528	Boom Center	1
7	17-529	Arm Pivot Hinge	2
	76-128	Bushing	4
8	HB-12-13-500	Bolt, $\frac{1}{2}$ - 13 x 5	2
	HNTL-12-13	Lock Nut, $\frac{1}{2}$ - 13	2
9	HB-38-16-250	Bolt, $\frac{3}{8}$ - 16 x $2\frac{1}{2}$	2
	HNTL-38-16	Lock Nut, $\frac{3}{8}$ - 16	2
10	17-530	Hinge Pin	2
	HB-516-18-075	Bolt, $\frac{5}{16}$ - 18 x $\frac{3}{4}$	2
11	17-541	Boom End Guard	2
	HBFL-516-18-075	Bolt, $\frac{5}{16}$ - 18 x $\frac{3}{4}$	4
	HNFL-516-18	Flange Lock Nut, $\frac{5}{16}$ - 18	4
12	17-532	Right Boom Arm	1
13	HSSQS-38-16-150	Square Head Set Screw , $\frac{3}{8}$ -16 x $1\frac{1}{2}$	2
14	33-506	Body (see nozzle drawing)	11
	HB-516-18-075	Bolt, $\frac{5}{16}$ -18 x $\frac{3}{4}$	11
	HNFL-516-18	Flange Lock Nut, $\frac{5}{16}$ -18	11
15	17-527	Boom Hinge	4
	HB-38-16-100	Bolt, $\frac{3}{8}$ - 16 x 1	16
	HNFL-38-16	Lock Nut, $\frac{3}{8}$ - 16	16
16	17-539	Compression Spring	4
17	9026-2	Rubber Duct Hose x 2"	4
18	17-540	Tapped Bolt	4
	HW-34	Washer, $\frac{3}{4}$	4
	HNTL-34-10	Lock Nut, $\frac{3}{4}$ -10	4
	HG-14-28-180	Grease Fitting, $\frac{1}{4}$ - 28 x 180°	4
19	17-535	Clean Load Mount	1
20	HB-38-16-300	Bolt, $\frac{3}{8}$ - 16 x 3	2
	HNTL-38-16	Lock Nut, $\frac{3}{8}$ - 16	2
21	HB-38-16-300	Bolt, $\frac{3}{8}$ - 16 x 3	2
	HW-38	Washer, $\frac{3}{8}$	2
	HNTL-38-16	Lock Nut, $\frac{3}{8}$ - 16	2
22	HB-12-13-300	Bolt, $\frac{1}{2}$ - 13 x 3	2
	HNTL-12-13	Lock Nut, $\frac{1}{2}$ - 13	2
23	17-537	Square U-bolt with Nut	4
24	8897-12	Discharge Hose 1-1/4"	4
25	16-557	Rubber Cap	1
26	18-234	1" Bushing (part of 17-553)	2
27	18-036	$\frac{1}{2}$ " Bushing (part of 17-553)	2
28	17-573	Guide Block	2
	HB-14-20-125	Bolt $\frac{1}{4}$ - 20 x $1\frac{1}{4}$	8
	HNFL-14-20	Flange Lock Nut $\frac{1}{4}$ - 20	8

TRIPLE NOZZLE ASSEMBLY

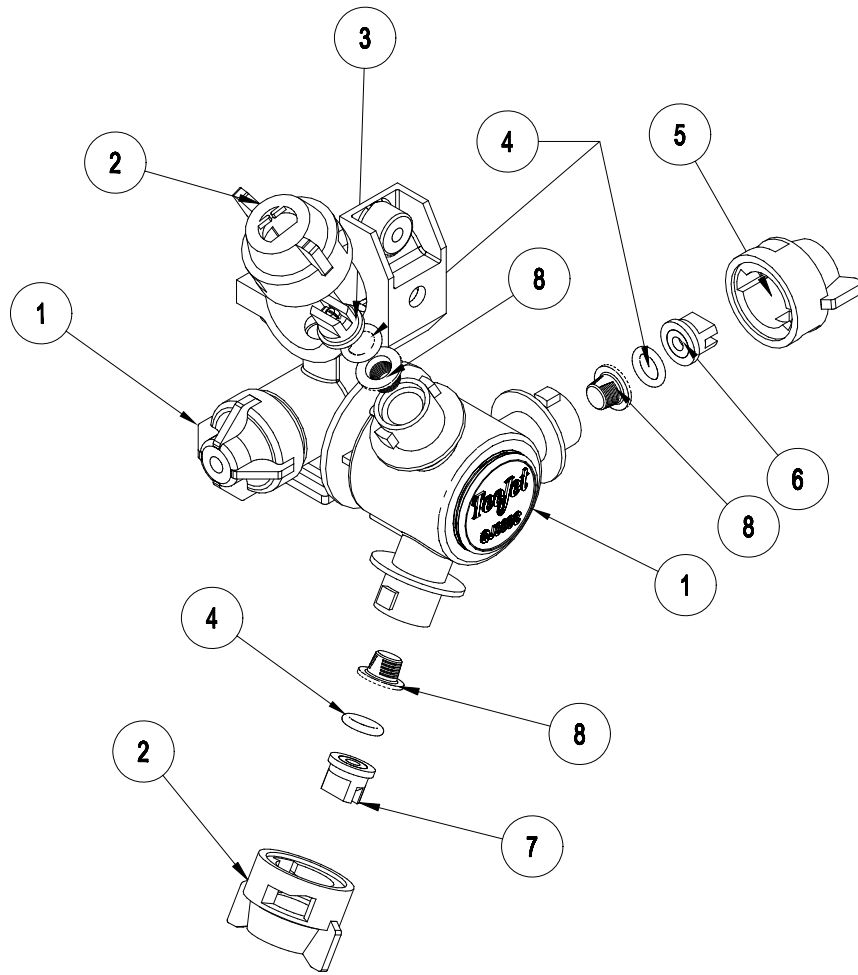

REF#	PART#	DESCRIPTION	QUANTITY
1	33-506	Body	1
2	33-538	Cap - Gray	2
3	33-553	Nozzle -Gray (XR11006-VS)	1
4	16-800	Viton Gasket	3
5	33-537	Cap - Red	1
6	33-552	Nozzle - Red (XR11004-VS)	1
7	33-554	Nozzle - White (XR11008-VS)	1
8	16-802	Strainer	3

Quantity is per nozzle body. For 20' booms multiply quantity by 12.

Quantity is per nozzle body. For 18' booms multiply quantity by 11.

Nozzles are located 20" (51 cm) apart on the right, left, and center tubes. Nozzles are 20" high off ground.

For reordering Nozzle Kits the following numbers apply

33-540 Triple Nozzle Kit for 18' Booms

33-542 Triple Nozzle Kit for 20' Booms

NOZZLE VALVE ASSEMBLY

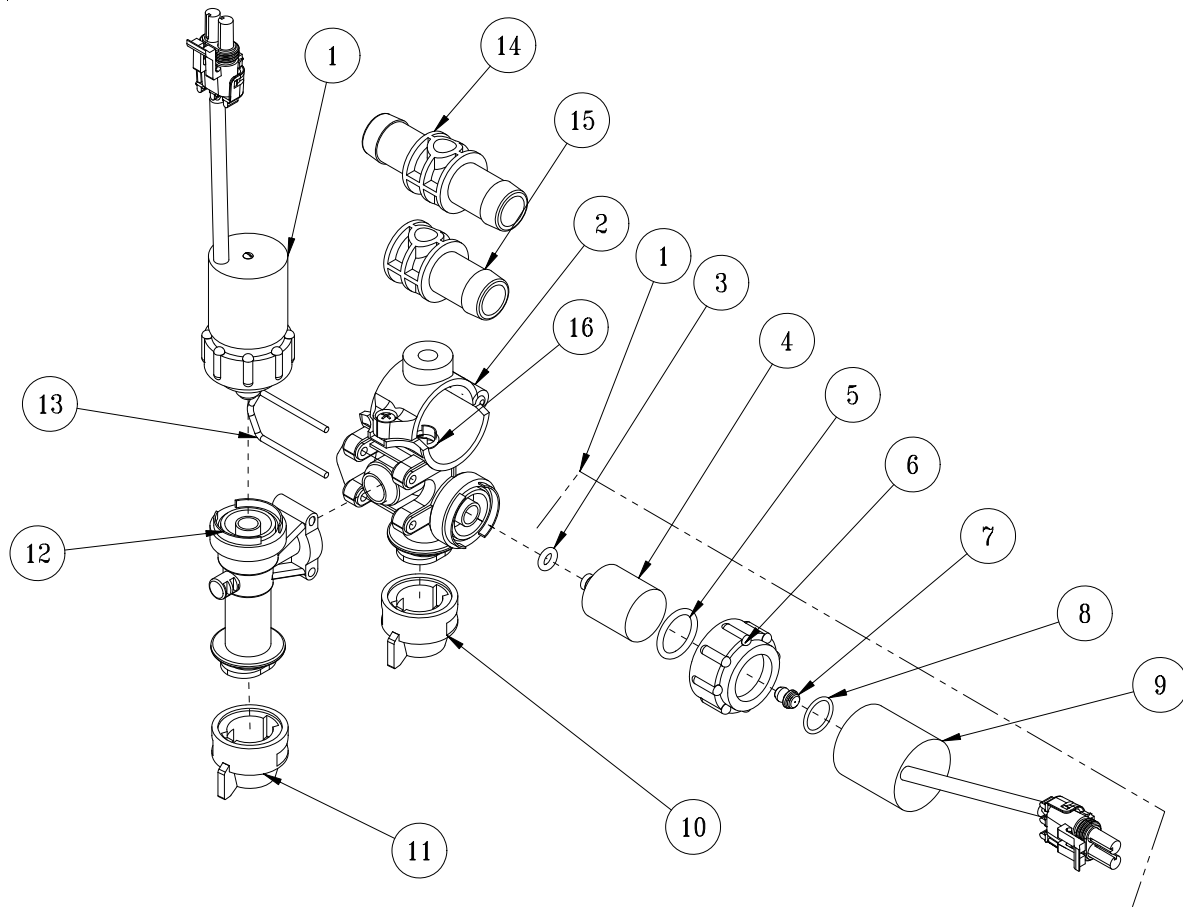

REF#	PART#	DESCRIPTION	QUANTITY
1	30-168-05	Complete Nozzle Valve Assembly (includes * items)	2
2	30-168-12	CR11 Saddle Assembly	1
3*	30-168-20	O-ring	1
4*	30-168-26	Valve Body	1
5*	30-168-18	O-ring	1
6*	30-168-25	Fly Nut	1
7*	30-168-17	Plunger	1
8*	30-168-19	O-ring	1
9*	30-168-21	Coil	1
10	30-168-13	Combo-Jet SR110-10	1
11	30-168-14	Combo-Jet MR110-10`	1
12	30-168-22	End Body Assembly	1
13	30-168-15	Lock U-Clip	1
14	30-170	Double Barb For SharpShooter	1
15	30-169	Single Barb for SharpShooter	1
16	30-168-28	Oring for Double or Single Barb	1

30-010 ELECTRIC HOSE REEL DRAWING

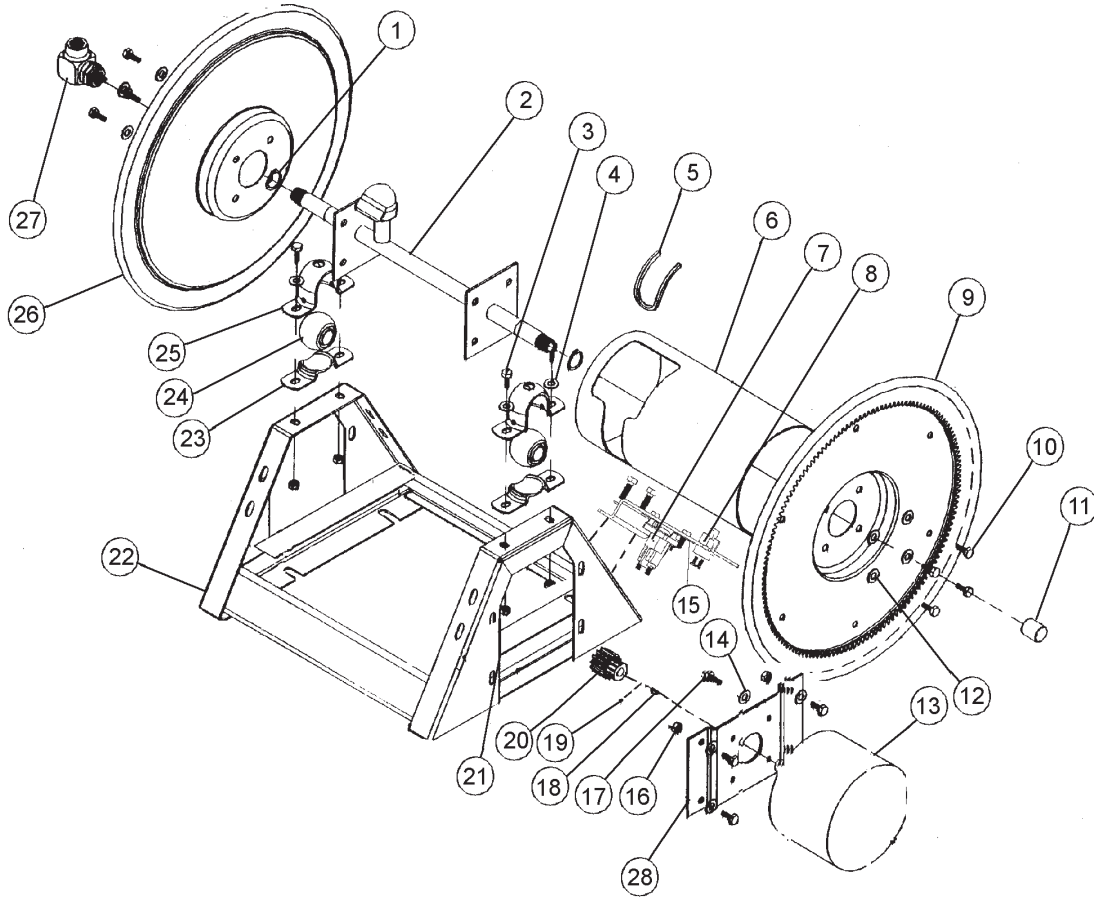

Accessories

30-010 ELECTRIC HOSE REEL PARTS LIST

REF#	PART#	DESCRIPTION	QUANTITY
1	16-906-25	Retaining Ring	2
2	16-906-22	Axle Assembly	1
3	HB-38-16-100	Bolt $\frac{3}{8}$ - 16 x 1	4
4	HW-38	Washer $\frac{3}{8}$	4
5	16-906-27	Trim, Drum Edge	1
6	16-906-21	Drum Center	1
7	13-750	Solenoid	1
	HB-14-20-075	Bolt $\frac{1}{4}$ - 20 x $\frac{3}{4}$	2
	HWL-14	Lockwasher $\frac{1}{4}$	2
	HN-14-20	Nut $\frac{1}{4}$ - 20	2
8	33-251	Switch	1
9	16-906-19	Disc and Gear Assembly	1
10	HB-516-18-075	Bolt $\frac{5}{16}$ - 18 x $\frac{3}{4}$	8
11	16-906-26	Pipe Cap $\frac{3}{4}$	1
12	HWL-516	Lockwasher $\frac{5}{16}$	8
13		Motor 12VDC	1
14	HW-516	Washer $\frac{5}{16}$	4
15	33-252	Switch and Solenoid Bracket	1
	HB-516-18-075	Bolt $\frac{5}{16}$ - 18 x $\frac{3}{4}$	2
	HW-516	Washer $\frac{5}{16}$	2
	HWL-516	Lockwasher $\frac{5}{16}$	2
	HN-516-18	Nut $\frac{5}{16}$ - 18	2
16	HNTL-516-18	Lock Nut $\frac{5}{16}$ - 18	4
17	HB-516-18-100	Bolt $\frac{5}{16}$ -18 x 1	4
18	16-906-17	Key	1
19		Set Screw	2
20	16-906-29	Pinion	1
21	HNTL-38-16	Lock Nut $\frac{3}{8}$ - 16	4
22	16-906-18	Frame Assembly	1
23	16-906-08	Mounting Pillow Block (Bottom)	2
24	16-906-24	Bearing	2
25	16-906-07	Mounting Pillow Block (Top)	2
26	16-906-20	Disc 17 $\frac{1}{2}$	1
27	16-906-23	Swivel Assembly $\frac{3}{4}$	1
	16-906-30	Seal Kit (For 16-906-23)	1
28	16-906-28	Bracket 12VDC	1
29	16-980	Mount Bracket	2
	HB-516-18-175	Bolt $\frac{5}{16}$ - 18 x 1 $\frac{3}{4}$	4
	HW-516	Washer $\frac{5}{16}$	4
	HNTL-516-18	Lock Nut $\frac{5}{16}$ - 18	4
	16-982	Electric Hose Reel (only)	1

ELECTRIC HOSE REEL WIRING DIAGRAM

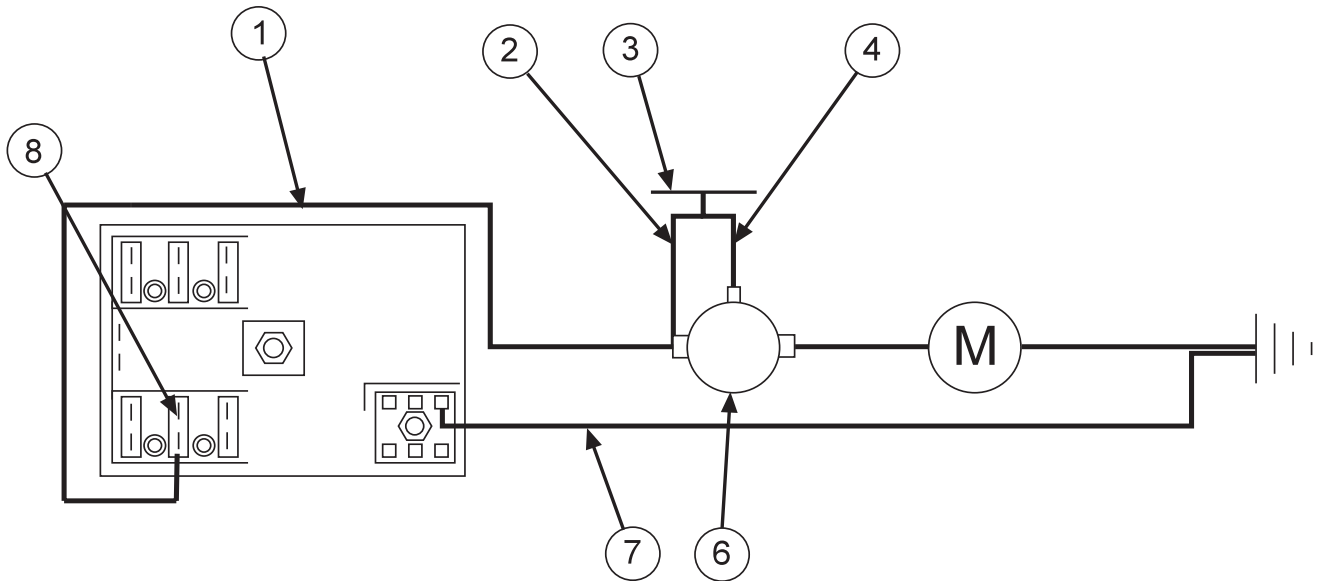

REF#	PART#	DESCRIPTION	QUANTITY
1	8843-132	Flexguard $\frac{3}{8}$ ID	1
	8919-144	10GA Red Wire 144"	1
	8901	Slide-On Connector	1
2	16-979	Wire, Switch to Solenoid Hot Terminal	1
3	33-251	Push Button Switch	1
4	16-978	Wire, Switch to Solenoid Start Terminal	1
6	13-750	Solenoid	1
SOLENOID TERMINALS			
	HN -516-24	$\frac{5}{16}$ - 24 Hex Nut	2
	HN -10-32	10 - 32 Hex Nut	1
7	8931-144	10GA White Wire 144"	1
	8901	Slide-On Connector	1
8	33-273	Auto Blade Type Fuse 30Amp	1

CONNECTION INSTRUCTIONS

Route wire harness along side of tank and over to fuse block taking care to stay clear of moving parts or hot engine components. Cut off excess wire and strip back $\frac{3}{8}$ ". Place one 8963 heat shrink ($\frac{1}{4} \times 1\frac{1}{4}$ ") on each wire before crimping 8901 slide on connectors to the red and white wires. Connect the two wires to the fuse block first the red to the (+) positive and the white to the (-) negative. Put the 33-273 auto blade type fuse (30 amp) into fuse block.



WARNING Make certain you are connecting positive (+) to positive; negative (-) to negative while attaching power leads. If you do not observe polarity, damage will result to electrical components.

Use Dielectric Grease On All Electrical Connections

30-009 MANUAL HOSE REEL DRAWING

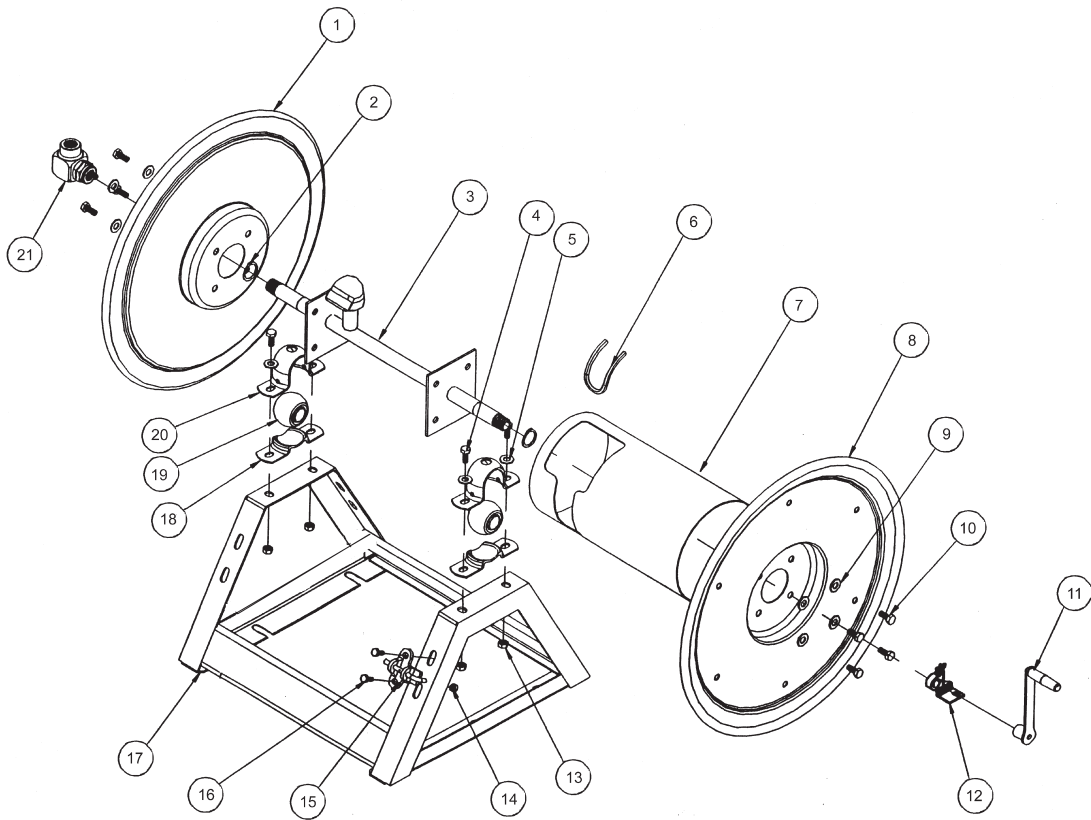

REF#	PART#	DESCRIPTION	QUANTITY
1	16-129-11	Disc 17 $\frac{1}{2}$	1
2	16-906-25	Retaining Ring	2
3	16-906-22	Axle Assembly $\frac{3}{4}$	1
4	HB-38-16-100	Bolt $\frac{3}{8}$ - 16 x 1	4
5	HW-38	Washer $\frac{3}{8}$	4
6	16-906-27	Trim, Drum Edge	1
7	16-906-21	Drum Center	1
8	16-906-20	Disc 17 $\frac{1}{2}$, Crank Side	1
9	HWL-516	Lockwasher $\frac{5}{16}$	8
10	HB-516-18-075	Bolt $\frac{5}{16}$ - 18 x $\frac{3}{4}$	8
11	16-129-09	Crank Assembly $\frac{3}{4}$	1
12	16-129-10	Brake Assembly $\frac{3}{4}$	1
13	HNTL-38-16	Lock Nut $\frac{3}{8}$ - 16	4
14	HNTL-516-18	Lock Nut $\frac{5}{16}$ - 18	2
15	16-129-08	Lock Pin Assembly	1
16	HB-516-18-075	Bolt $\frac{5}{16}$ - 18 x $\frac{3}{4}$	2
	HW-516	Washer $\frac{5}{16}$	2
17	16-129-07	Frame Assembly	1
18	16-906-08	Mounting Pillow Block (Bottom)	2
19	16-906-24	Bearing	2
20	16-906-07	Mounting Pillow Block (Top)	2
21	16-906-23	Swivel Assembly $\frac{3}{4}$	1
	16-906-30	Seal Kit (For 16-906-23)	1
22	16-980	Mount Bracket	2
	HB-516-18-1	Bolt $\frac{5}{16}$ - 18 x 1	4
	HW-516	Washer $\frac{5}{16}$	4
	HNTL-516-18	Lock Nut $\frac{5}{16}$ - 18	4

HOSE REEL MOUNT DRAWING

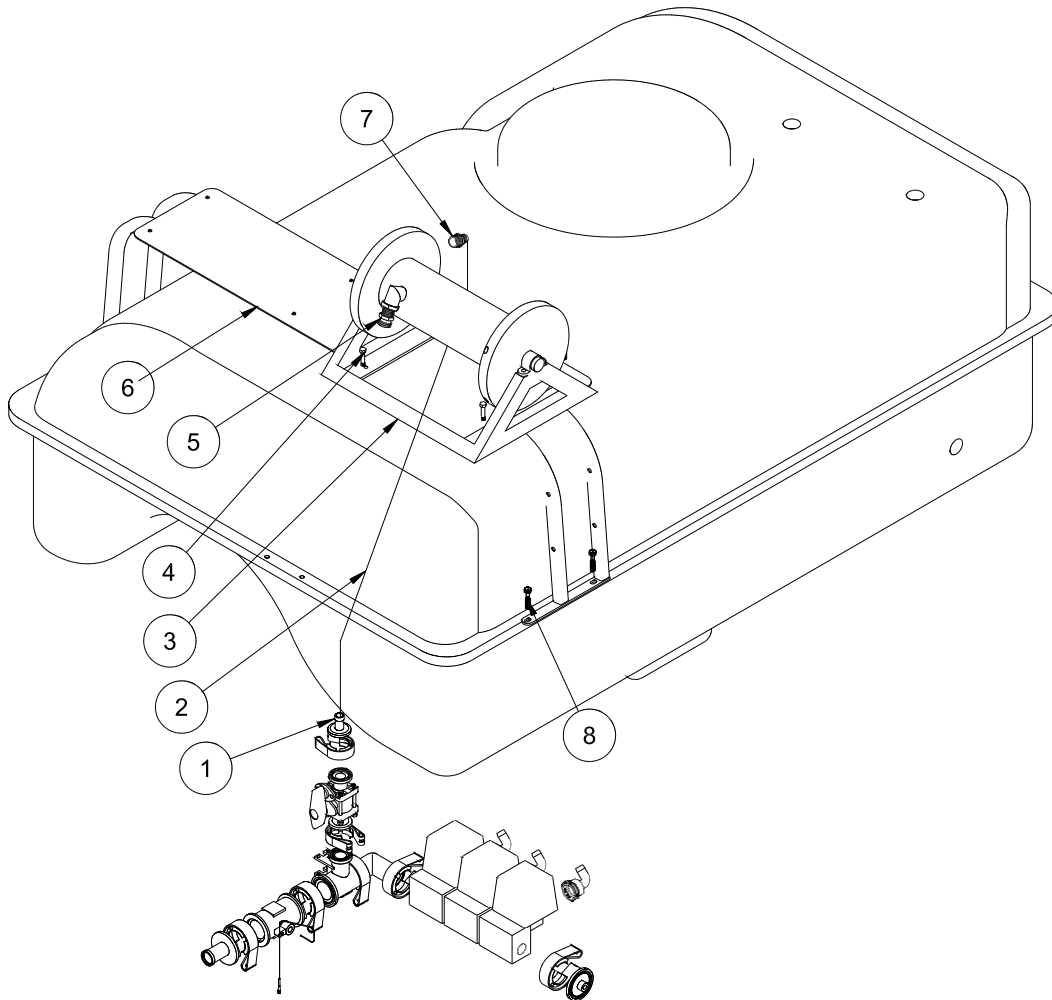

HOSE REEL MOUNT PARTS LIST

REF#	PART#	DESCRIPTION	QUANTITY
1	15-749	Hose Barb $\frac{3}{4}$ "	1
2	8887-110	$\frac{3}{4}$ " Orange PVC Hose 110"	1
	18-040	Hose Clamp	2
3	16-129	Manual Rewind Hose Reel	1
4	HB-516-18-100	Bolt $\frac{5}{16}$ " -18 x 1	4
	HW-516	Washer $\frac{5}{16}$ "	4
	HNTL-516-18	Lock Nut $\frac{5}{16}$ " - 18	4
5	16-295	Hose Fitting $\frac{3}{4}$ "	1
6	30-110	Hose Reel Mount bracket (part of 30-005-K)	1
7	18-249	Barb Fitting	1
8	HB-516-18-175	Bolt, $\frac{5}{16}$ " -18 x $1\frac{3}{4}$ " (part of 30-005-K)	4
	HNFL-516-18	Flange Lock Nut, $\frac{5}{16}$ " - 18 (part of 30-005-K)	4

1. Wear protective clothing when draining the tank and taking apart the lines.
2. Drain tank and spray system in a safe and approved method insuring that no chemical or water remain in tank as you will be taking apart lines.
3. Remove key from ignition, set park brake and block wheels.
4. Put hose reel on hose reel bracket with fitting to the rear of machine. Use four bolts $\frac{5}{16}$ " - 18 x 1 and four $\frac{5}{16}$ " - 18 lock nuts to hold in place. Tighten bolts.
5. Put 18-249 barb fitting into hose reel side.
6. Place the 16-295 Hose Fitting into the Hose reel center.
7. Remove the blank cover from the ball valve by the manifold valve and place the 15-749 Hose Barb. Tighten clamp.
8. Route hose from the hose barb on the ball valve to the barb fitting on the side of the hose reel. Hold in place with the two 18-040 clamps.
9. Be sure all clamps and hardware are tight before using.

HOSE REEL ADJUSTMENTS

OPERATIONAL CHECK:

1. Pull hose off drum at least one full revolution. A clicking noise should be heard from locking mechanism.
2. Let the hose retract.
3. Pull the hose off until the first click is heard. Drum should lock when the hose tension is removed.
4. Continue pulling the hose, no more than one revolution, until no clicking is heard. Hose should rewind when tension is removed.

HOSE REPLACEMENT PROCEDURE:

1. Facing swivel, turn the hose drum clockwise until all of the hose is removed from the drum and the drum is held by locking mechanism. Make sure spring is locked.
2. Remove hose clamps and disconnect hose from swivel. Remove old hose.
3. Insert new hose through roller guide, connect to swivel and reinstall hose clamps. Use spring guard over hose to protect the hose from being cut by the drum.
4. Remove check ball from old hose and install on replacement hose.
5. Carefully, keeping the tension on the hose, pull the hose to release the locking mechanism. Let the hose wind on the drum.

30-004 FOAM MARKER DRAWING

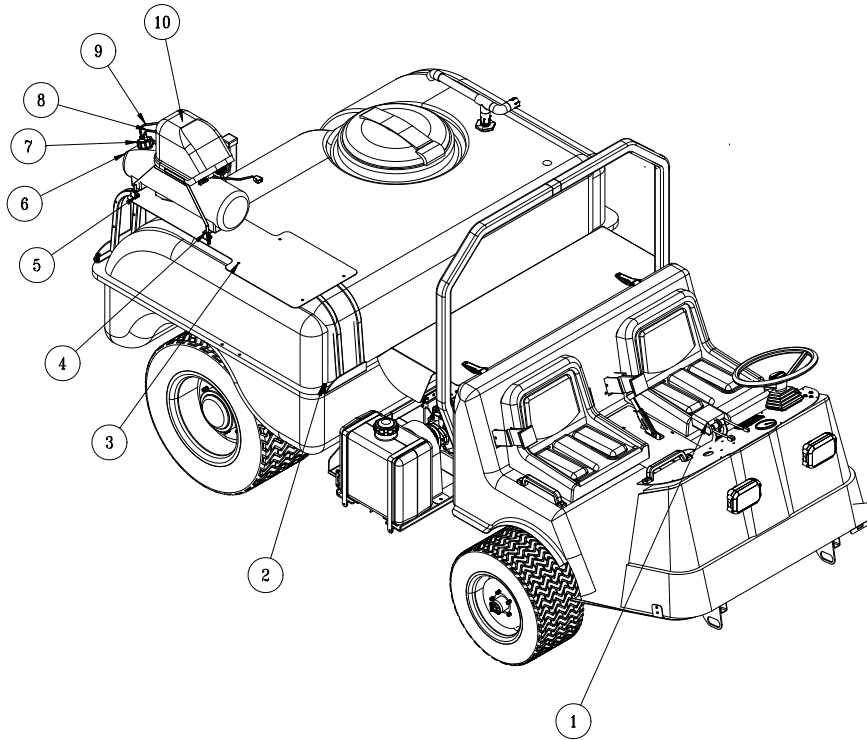

WIRING DRAWING

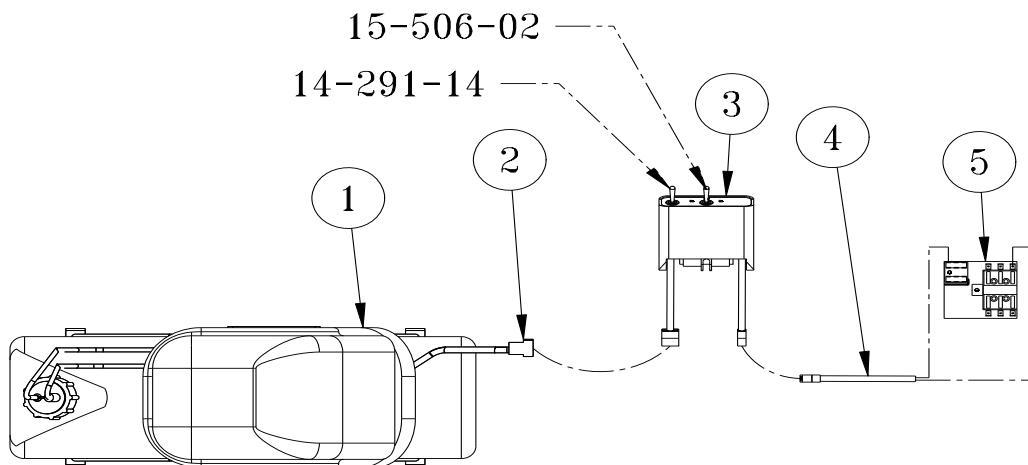

Accessories

30-004 FOAM MARKER PARTS LIST

REF#	PART#	DESCRIPTION	QUANTITY
1*	14-291-05	Double Switch Box	1
	33-508	Fuse	1
	15-506-02	Center Switch	1
	14-291-14	Switch	1
2	HB-516-18-175	Bolt, $\frac{5}{16}$ -18 x $1\frac{3}{4}$ (part of machine)	4
	HNFL-516-18	Flange Lock Nut, $\frac{5}{16}$ - 18 (part of machine)	4
3	30-110	Mount Bracket (part of machine)	1
4*	14-291-04	Tank Bracket	2
5	HN-14-20-075	Hex Bolt, $\frac{1}{4}$ -20 x $\frac{3}{4}$	2
	HBFL-14-20	Flange Lock Nut, $\frac{1}{4}$ -20	2
6*	14-291-02	Foamer Tank	1
7*	14-284-02	Cap Assembly	1
8*		Blue Tube	1
9*		Clear Tube	1
10*	14-291-03	Compressor Only	1
	14-291-01	Black Cover	1
*	14-291	Foamer (includes * parts)	1

REF#	PART#	DESCRIPTION	QUANTITY
1	14-291-03	Compressor	1
2	15-504-04	Wiring Harness	1
3	14-291-05	Switch Box	1
	33-508	Fuse	1
	15-506-02	Center Switch	1
	14-291-14	Outside Switch	1
4	15-509	Power Cable	1
5	33-271	Fuse Block (part of machine)	1
	33-293	Auto Blade Type Fuse 30 amp	1

30-004 FOAM MARKER DRAWING

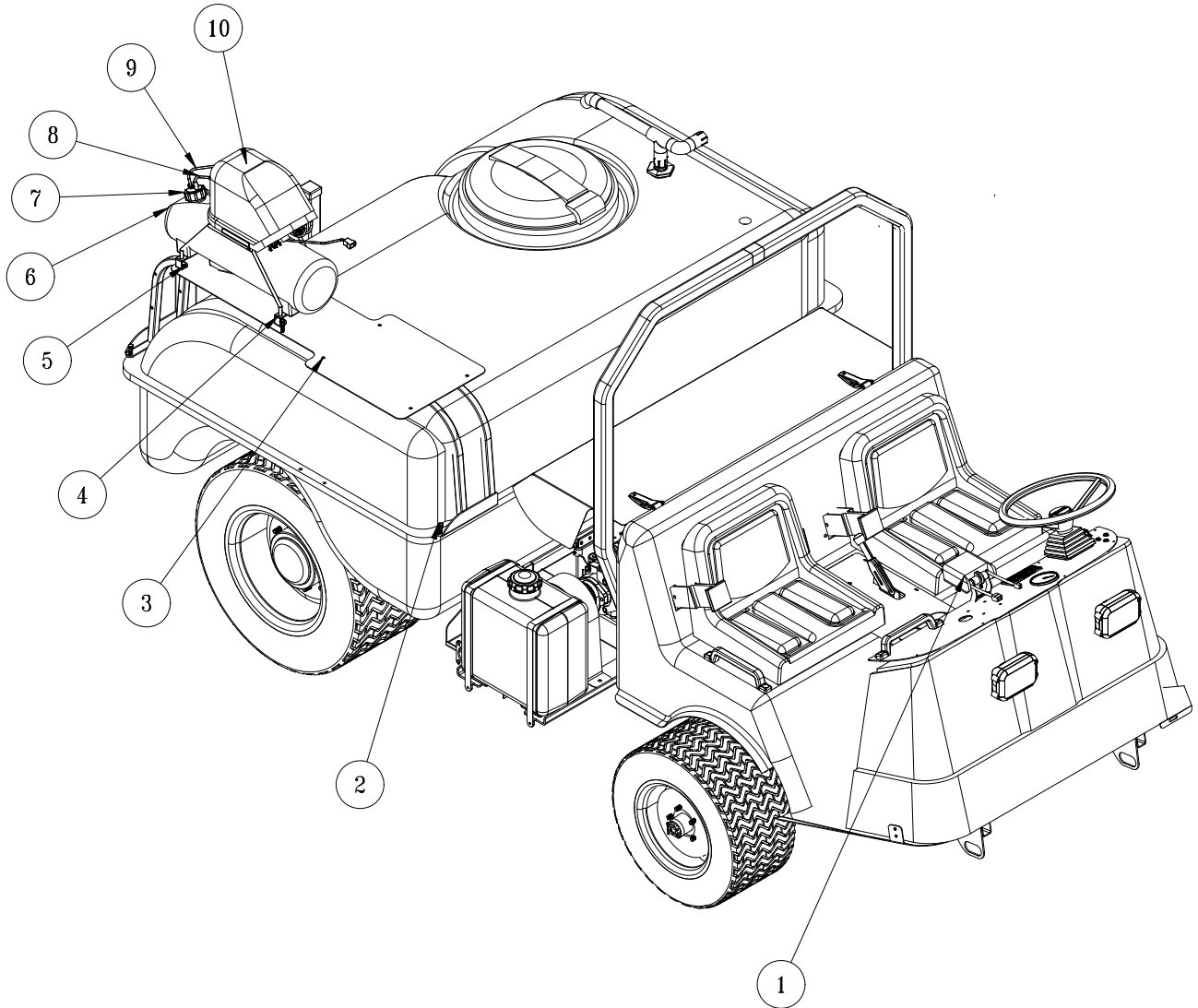

Accessories

INSTALLATION INSTRUCTIONS

Safety: Before working on machine stop engine, set park brake, remove key from ignition and block wheels. Disconnect negative (-) battery terminal.

BOX MOUNT

Mount the switch box to the lower center of the dashboard. Remove the two phillips head bolts. Reinstall the #10 x 1 phillips head bolts and lockwashers to hold the switchbox onto the dashboard. Tighten all bolts.

WIRING

Use dielectric grease on all electrical connections. Connect power cable (15-509) to the switch box. Turn the switch off. Route the power wire down through the grommet in the dashboard. Follow the wire harness down under the floorboard, then back along the main frame and up to the fuse block in the engine compartment behind the passenger seat. The power cable will need to be cut and shortened. Attach slide-on terminals to the wire ends with heat shrink, then connect to fuse block. Red to positive(+), black to negative(-). Insert 10 AMP fuse into slot which has red wire attached to it.

Route Control Harness (15-504) from switch box on dashboard same as the power wire. Only continue all the way to the rear of the machine. Then pull the cable up over the back of the spray tank so it can be connected to the compressor.

CONNECTING THE CAP ASSEMBLY

Connect the blue tube to the tank cap connector which is also connected to the large blue tube which hangs below the cap. This is the soap outlet tube. Connect the clear tube to the other connector on the tank cap. This is the air input tube. Tighten connectors hand tight, assembly tank cap onto tank.

HOSES

Being careful not to cut the tubing, cut the oversleeve back approximately 2" (5 cm) to expose blue and clear tubing. Remove blue wing nut from top connector of foam nozzle and slide it on the blue tube with the threads facing toward end of tube. Slide blue tube all the way over the top of the small tube on foam nozzle. Slide wing nut back to the threads and hand tighten. Follow the same steps for the clear tube and tube nut.

Route the tubing along underside of main frame using tie downs as necessary.

Install opposite ends of air-liquid tubes to compressor, again cutting back the oversleeve approximately 2" (5 cm) and inserting blue and clear tubes for the left boom section into the tubing connectors on the right side of compressor as far as possible. Follow the same steps for the right boom tubing. Notice the right boom is inserted into left side of compressor. To release tubing from compressor, hold black ring around tubing, and pull tube out.

FOAMER NOZZLE MOUNT & HOSE GUARD MOUNT DRAWING

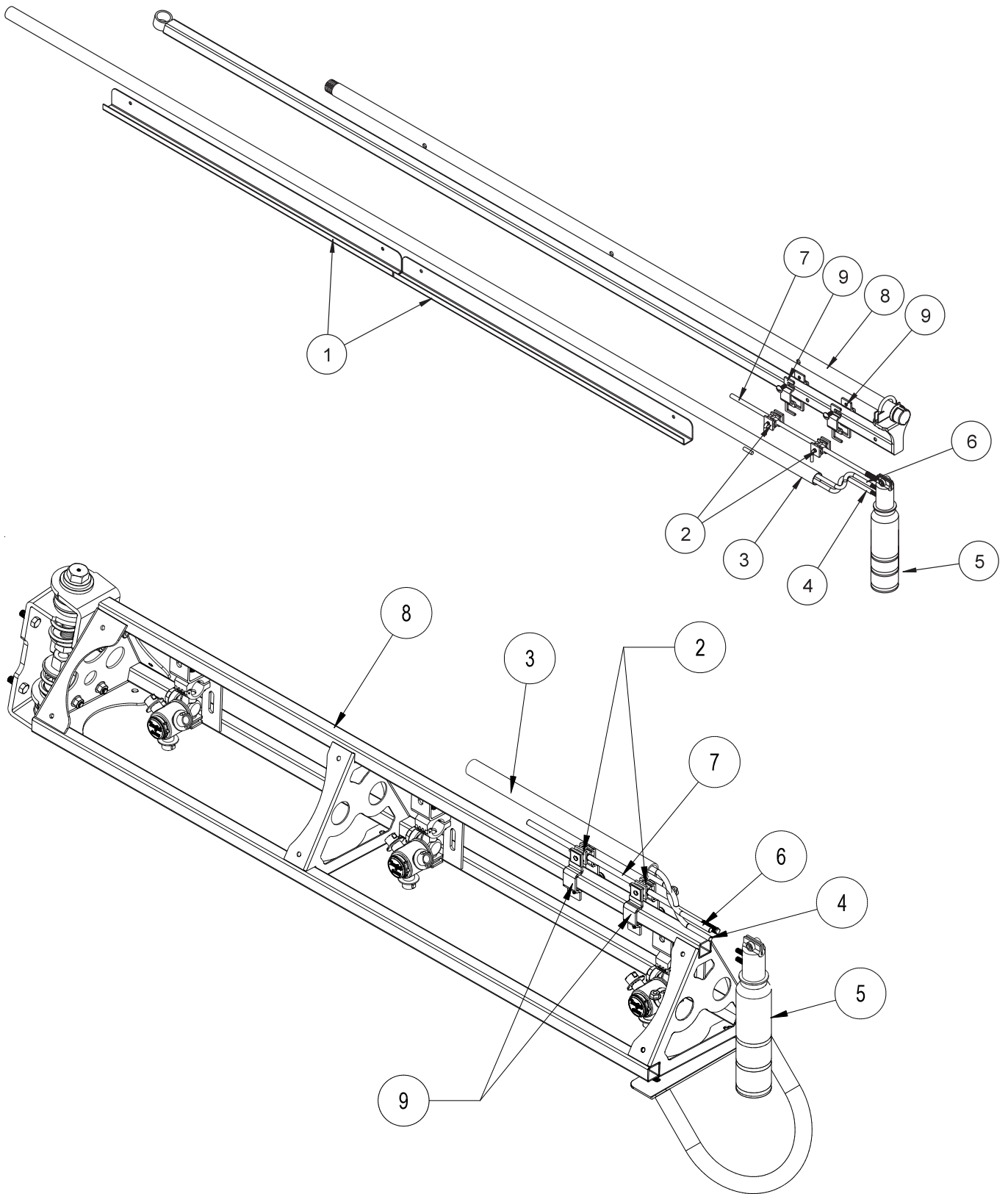

Accessories

30-162 FOAM MARKER PARTS LIST

REF#	PART#	DESCRIPTION	QUANTITY
1	15-537	Foamer Hose Guard 31"	4
	HSDPS-14-075	Stainless Steel Pan Head Drill Screw $\frac{1}{4} \times \frac{3}{4}$	8
2	16-987	Foam Nozzle Mounting Kit	1 per boom
3	15-507	Foamer Tubing	1
4		Clear Tubing	
5	15-511	Foam Nozzle	2
6		Blue Tubing	
7	15-510-01	Nozzle Mounting Rod	2
8		Boom	
9	16-795	Square Clamp	4

- Slide hose clamp onto drop tube of foam nozzle and attach restrictor bell.
- Place splined end of Nozzle mounting rod (Ref 7) into top of foam nozzle (Ref 5). Tighten screw.
- Slide two foam nozzle mounts (Ref 2) onto the rod. Place square clamps (Ref 9) on foam nozzle mounts and mount the square clamps to the boom (Ref 8). Adjust foam nozzle mounts and clamps so nozzle assembly will clear end of boom. Tighten foam nozzle mounts and square clamps to prevent side to side movement. Do the same to the other side.
- Being careful not to cut the tubing (Ref 3), cut the oversleeve back approximately 2" (5 cm) to expose blue (Ref 6) and clear tubing (Ref 4).
- Remove blue wing nut from top connector of foam nozzle and slide it on the blue tube with the threads facing toward end of tube. Slide blue tube all the way over the top of the small tube on foam nozzle. Slide wing nut back to the threads and hand tighten. Follow the same steps for the clear tube and tube nut.
- Route the tubing along underside of main frame using tie downs as necessary.
- Install opposite ends of air-liquid tubes to compressor, again cutting back the oversleeve approximately 2" (5 cm) and inserting blue and clear tubes for the left boom section into the tubing connectors (Ref A) on the right side of compressor as far as possible.
- Follow the same steps for the right boom tubing. Notice the right boom is inserted into left side of compressor. To release tubing from compressor, hold black ring around tubing, and pull tube out.
- Hose's must be routed on bottom of the boom square tubing.
- Mark 6 inches in from inside edge of foamer nozzle mounting bracket on square boom tubing.
- Place hose guard (Ref 1) flush with top of square tubing with edge on previous mark. The channel covers hoses on the bottom of the square tubing.
- Install hose guard using 2 drill screws (you may want to drill a $\frac{3}{16}$ pilot hole first).
- Place another hose guard against first and install in same manner.
- Repeat process for other boom side.
- Connect small plastic electrical plug under compressor to electrical extension cable.
- For *Spray Star 1600* route extension cable under engine along the mainframe cross bar, using tie downs as necessary.
- Cut cable and strip casing, allowing enough length to connect to fuse block.
- Strip and connect slide on connectors to each wire and use the heat shrink.
- Connect black negative (-) wire to the ground and connect red wire to the positive (+).
- Insert 10 amp fuse into slot which red wire was attached to.

FOAM MARKER DRAWING



Accessories

REF#	PART#	DESCRIPTION	QUANTITY
1	15-507	Foamer Tubing	1
2	14-291-02	Tank	1
3	14-291-01	Black Cover	1
	14-291-03	Compressor Complete	1
4	14-284-02	Cap Assembly	1
5	14-291-04	Tank Bracket	1
6	14-291-05	Double Switch Box	1
7	15-511	Foam Nozzle	1
8	15-510-01	Nozzle Mounting Rod	1
9	16-987	Foam Nozzle Mounting Kit	1
	14-536	Compressor Sub-assembly	

15-511 FOAM NOZZLE SUB ASSEMBLY DRAWING

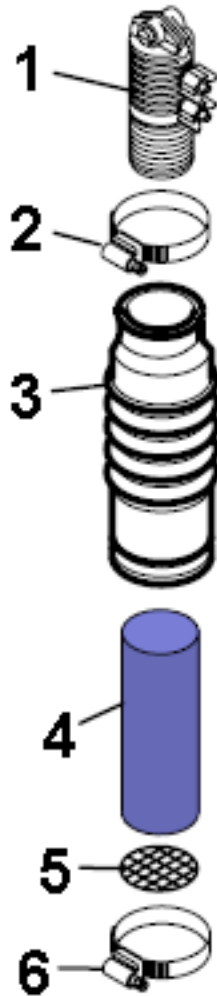

Accessories

REF#	PART#	DESCRIPTION	QUANTITY
1*	15-511-01	Foam Nozzle Inlet Body	1
	15-511-02	Foam Sponge	1
	15-511-10	Plastic Screen	1
2*		Hose Clamp	1
3*		Drop Tube	1
4	15-511-08	Long Foam Sponge	1
5	15-511-09	Stainless Steel Screen	1
6		Hose Clamp	1
NS	15-510-01	Nozzle Mounting Rods	2
*	15-511-07	Foam Nozzle Sub Assembly	

14-515 WATER METER KIT (GALLONS)

15-618 WATER METER KIT (LITERS)

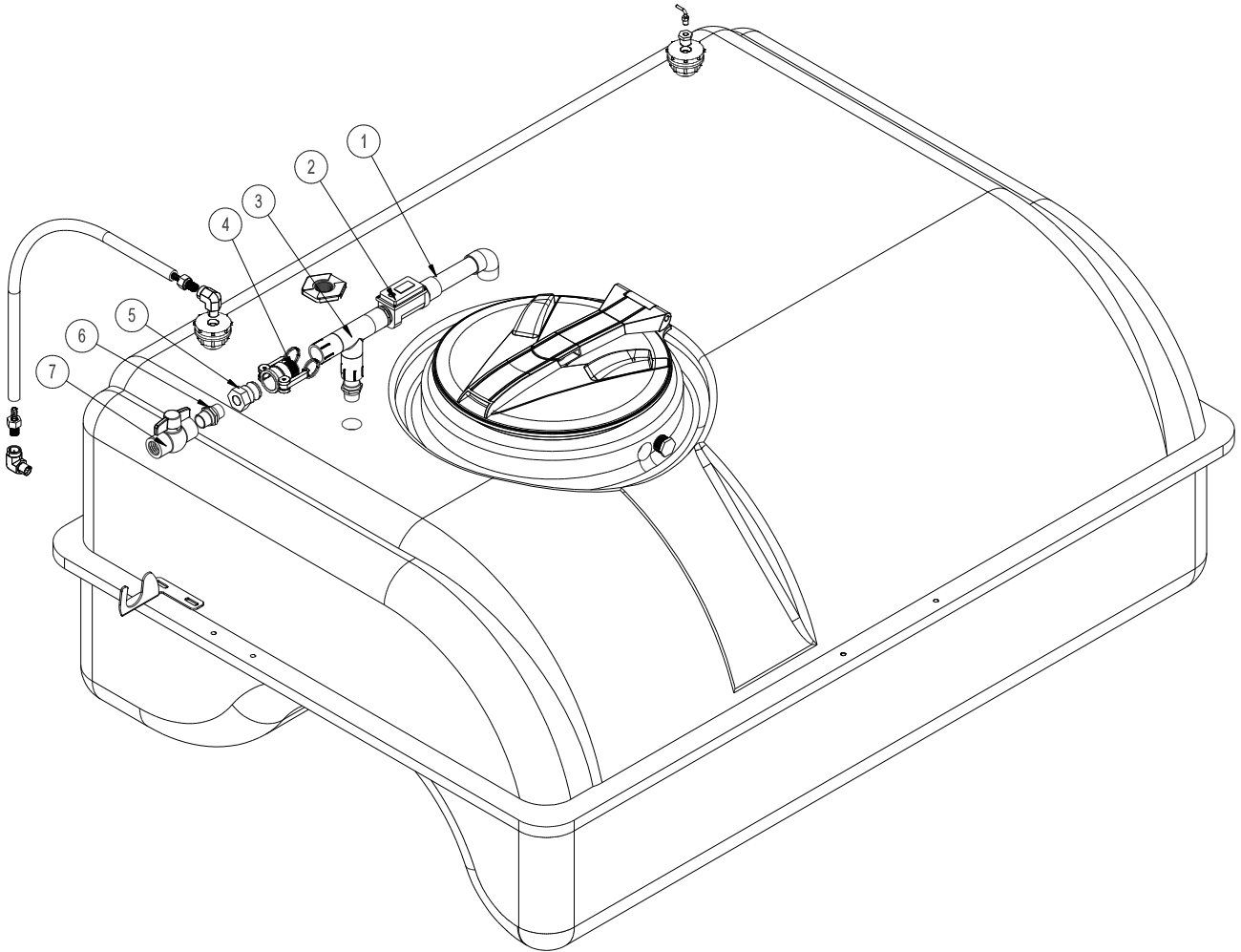

REF #	PART #	DESCRIPTION	QUANTITY
1	14-524	Filler Outlet	1
2	14-514	Water Meter (Gallons)	1
	14-527	Water Meter (Liters)	1
3	14-525	Filler Inlet	1
4	16-962	1" Quick Coupler (already on machine)	1
5	16-961	1" Adapter Quick Coupler (already on machine)	1

1. Thoroughly flush the service line upstream of the meter to remove dirt and debris.
2. The DLJ Meter is for use **only** with **COLD WATER** up to 122°F (50°C)
3. Slowly open any upstream valves to prevent damage to the meter.

Gallons to Cubic feet Conversion :

Multiply gallons reading by 0.1337 to get cubic feet.

There are 7.48052 gallon per cubic foot.

30-006 FRESH WATER TANK DRAWING

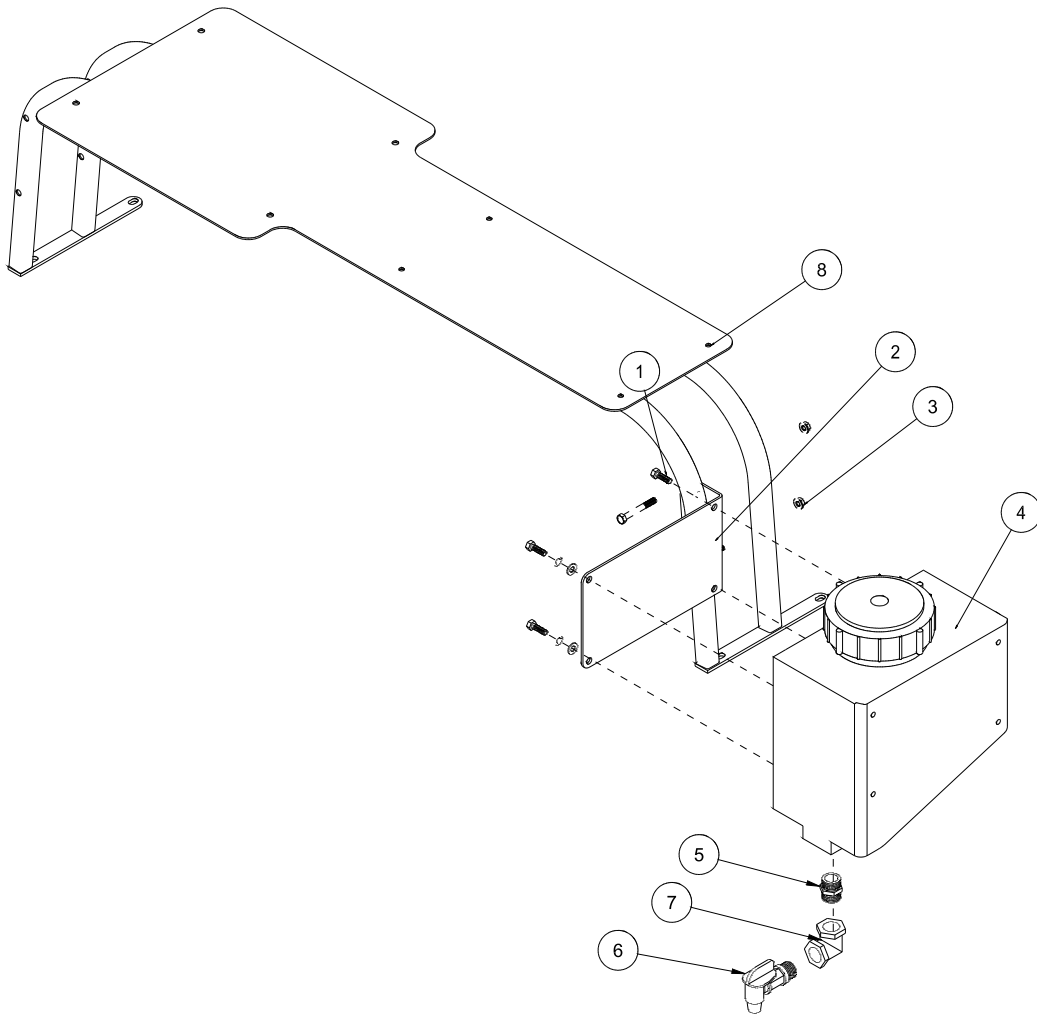

30-006 FRESH WATER TANK PARTS LIST

REF#	PART#	DESCRIPTION	QUANTITY
1	HB-516-18-075	Bolt $\frac{5}{16}$ - 18 x $\frac{3}{4}$	4
	HW-516	Washer $\frac{5}{16}$	4
	HWL-516	Lock Washer $\frac{5}{16}$	4
2	30-111	Tank Mount Bracket	1
3	HB-516-18-150	Bolt $\frac{5}{16}$ - 18 x $1\frac{1}{2}$	2
	HNFL-516-18	Flange Lock Nut $\frac{5}{16}$ - 18	2
4	10-234	3 Gallon Rectangular Tank	1
	10-234-01	Lid	1
5	16-158	Close Nipple $\frac{3}{4}$ x $\frac{3}{4}$	1
6	16-960	Spigot $\frac{3}{4}$ NPT	1
7	16-151	Elbow FPT $\frac{3}{4}$ x $\frac{3}{4}$	1
8	30-110	Mount Bracket (part of machine)	1

INSTALLATION INSTRUCTIONS

1. Fresh Water Wash Tank mounts on the rear of the machine.
2. Clamp the mount bracket to the Mount Bracket and mark the holes onto the tube with a center punch. Drill the two holes using a $\frac{3}{8}$ drill bit.
3. Secure the bracket to the post with two $\frac{5}{16}$ x $1\frac{1}{2}$ bolts and flange lock nuts. Then tighten.
4. Install the nipple (Ref 5), elbow (Ref 7) and spigot (Ref 6) into the bottom of wash tank (Ref 4). Use thread tape on all threads.
5. Mount the tank onto the mount bracket (Ref 2) using four $\frac{5}{16}$ x $\frac{3}{4}$ bolts, washers and lockwashers. Tighten.
6. Rinse tank with clear water and check for leaks around fittings.



WARNING

This tank is for fresh clear water **ONLY**. Do not put chemicals in this tank.

30-007 CHEMICAL CLEANLOAD DRAWING

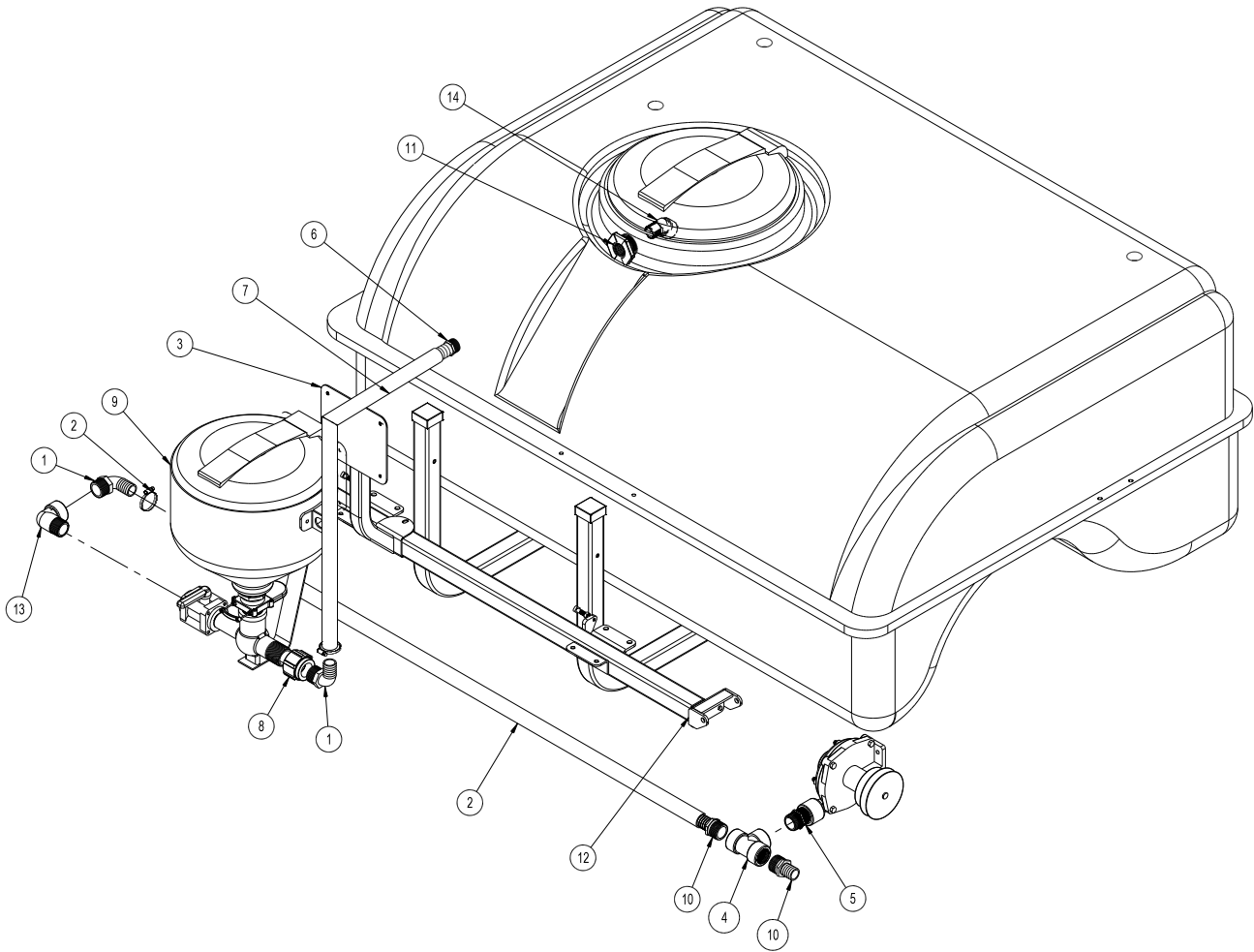

Accessories

REF#	PART #	DESCRIPTION	QUANTITY
1	16-156	Elbow	2
2	8897-90	1 1/4" Discharge Hose 90"	1
	18-116	Hose Clamp	2
3	15-816	Cleanload Mount	1
	HBFL-516-18-075	Flange Bolt	4
	HNFL-516-18	Flange Lock Nut	4
4	18-390	Pipe Tee	1
5	16-880	Close Nipple	1
6	16-159	Fitting	1
7	8897-38	1 1/4" Discharge Hose 38"	1
	18-116	Hose Clamp	2
8	18-391	Coupling	1
9	15-620	Cleanload Assembly	1
10	16-161	Fitting	2
11	16-945	Fitting (part of tank)	1
12		Center Boom	1
13	16-972	90° Elbow	1
14	16-971	45° Elbow (goes inside a tank)	1

OPERATING INSTRUCTION

STARTUP

1. All Cleanload valves must be closed prior to starting: inlet ball valve, knife valve and hopper rinse ball valve.
2. Open lid to check for foreign objects which may hinder performance or contaminate the system.
3. Close and lock lid by turning cover clockwise.
4. Divert pump flow to Cleanload inlet line. A pressure of 30 PSI minimum and 150 PSI maximum must be used. Highest pressures increase education rate and available wand suction.
5. Turn inlet ball valve on (yellow handle).
6. Open knife valve, located on the bottom of hopper, by pushing handle in (red handle).
7. Unlock and open lid slowly by turning cover counterclockwise.

LOADING LIQUID OR POWDERED CHEMICAL INTO HOPPER

8. Pour required amount of chemical into hopper. Avoid splashing liquids or powdered chemicals outside of hopper.
9. Rinse empty chemical containers if applicable. Place container opening over container rinse valve and press down. This will activate the rinse valve and rinse container.
10. Rinse Cleanload hopper. Close and lock lid by turning cover clockwise. Release the safety locking band on the hopper rinse ball valve and turn on for 20 seconds. Close ball valve and return locking band to locked position.
11. Open lid and inspect for chemical residue. Repeat step 10 as necessary.
12. Close knife valve by pulling red handle out towards you. Turn inlet (yellow handle) off.

LOADING LIQUID AND/OR POWDERED CHEMICAL WITH SUCTION LANCE

Note: Lance suction is dependent upon eductor pressure and flow. For best results, use highest pressure available up to 150 PSI maximum.

8. Insert lance body with o-ring into eductor until the o-ring is sealed.
9. Use the free end of the lance to pierce bag or container to vacuum powdered or liquid chemical.
10. Rinse lance. Place lance end into a clean container of water to rinse lance assembly.
11. Remove lance body from eductor and drain any remaining fluid into hopper.
12. Close knife valve (red handle). Turn inlet valve (yellow handle) off.

SHUTDOWN

1. Ensure that:
 - All valves are closed. Be sure to close knife valve first. (Close by pulling red handle out towards you.)
 - Chemical residue has been cleaned.
 - Hopper lid is closed and locked by turning cover clockwise.
2. Divert pump flow back to normal operation.

Symptom	Corrective Action
Low education rate	Check pump pressure and flow. Cleanload Eductor performance is based on flow and pressure to the system. Note requirements for high education rates. hoses outlet hoses are back to tank.
Plugged or clogged bottle rinse nozzle	Disassemble to by-pass nozzle from lance valve assembly and back flush until nozzle ports are clear of debris.
Plugged or clogged tank rinse nozzle	Disassemble to by-pass nozzle from NPT hose barb and back flush until nozzle ports are clear of debris. Remove screen and flush with water to clear any foreign material.
Filling leaks	Check for cracks in fitting. Replace fitting if necessary. Disassemble and add more joint seal in compound if leak occurs on threads.

15-620 CHEMICAL CLEANLOAD® PARTS DRAWING

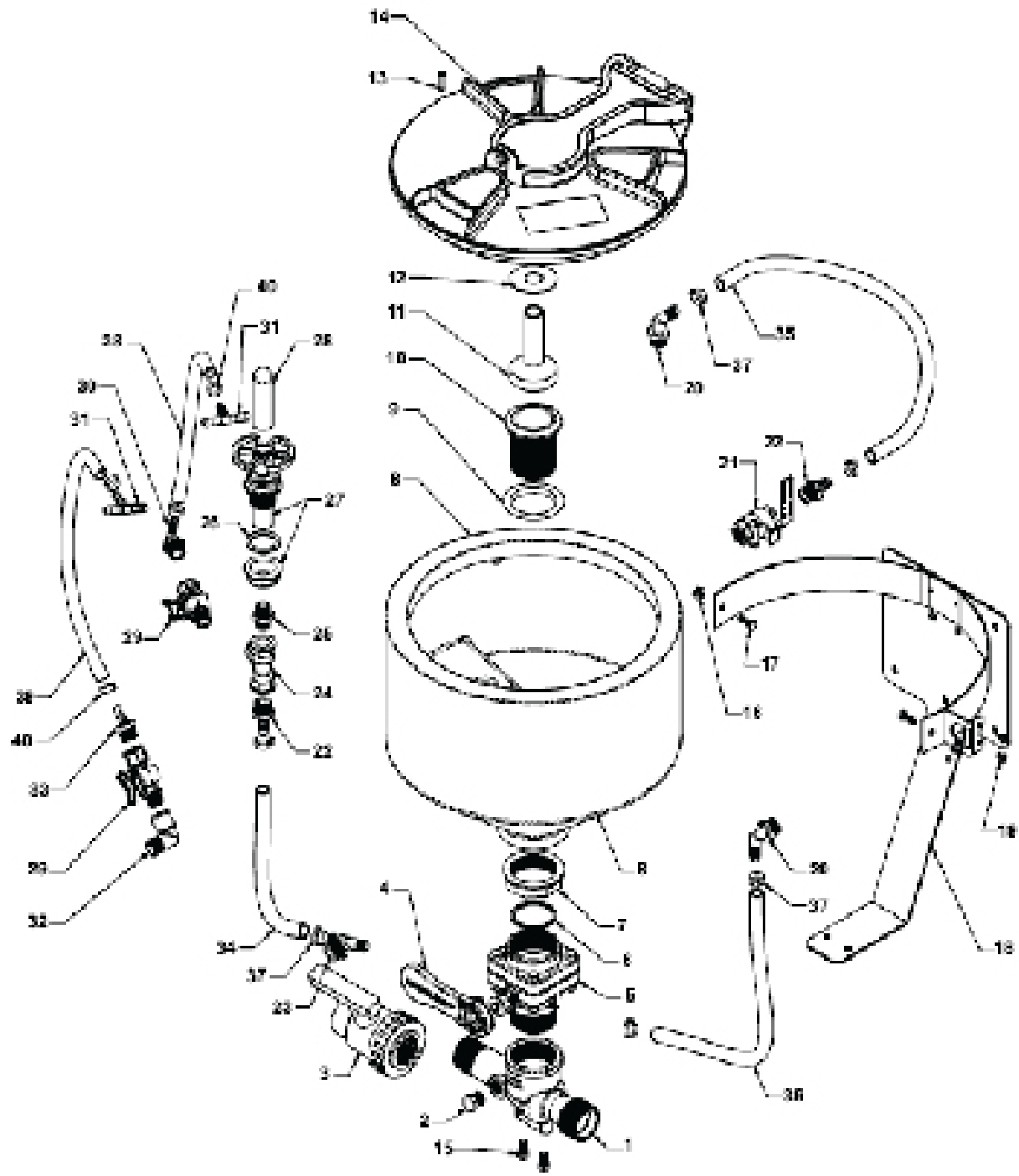

Accessories

15-620 CHEMICAL CLEANLOAD® PARTS LIST

REF#	PART#	DESCRIPTION	QUANTITY
1	15-620-04	Cleanload Eductor	1
2		Plug, 1/2"	1
3	15-620-14	Ball Valve, 1 1/4" Single Union	1
4	15-620-13	Handle, Cleanload	1
5	15-620-12	Ball Valve	1
6	15-620-15	Gasket: 2" BSP	1
7	15-620-16	Locking Ring, 2"	1
8		Tank	1
9	15-620-17	Gasket: 2", Tapered	1
10	15-620-18	Drain Head, 2"	1
11	15-620-19	Tank Rinse	1
12		Slinger Ring	1
13		Screw, #6 x 1"	8
14	15-620-02	Tank Lid	1
15		Bolt, 5/16"-18 x 5/8	2
16		Nut, Flanged 1/4" - 20	2
17		Bolt, 1/4" - 20 x 3/4" SS	2
18	15-620-01	Frame, Back Mount	1
19		Screw, 10-24 x .375	2
20	15-620-11	Elbow 1/2"	2
21	15-620-10	Valve, SS Tank Rinse	1
22	15-620-09	HB, 1/2" MNPT x 1/2" HB	2
23	15-620-05	HB Tee, 1/2" MNPT to 1/2" HB	1
24		Tee, 1/2" FNPT	1
25		Nipple, 1/2"	1
26	15-620-20	Gasket, 1"	1
27		Valve, Bottle Rinse Base Assy.	1
28		Bottle Rinse Head	1
29		Valve, 1/2"	1
30		HB Elbow, 1/2" MNPT x 3/8" HB	1
31		HB Tee, 3/8"	1
32		1/2" Street Elbow	1
33		HB, 1/2" MNPT x 3/8" HB	1
34	15-620-07	Hose, Bottle Rinse, 1/2" EPDM	1
35	15-620-08	Hose, Tank Rinse, 1/2" EPDM	1
36	15-620-06	Hose, Valve Feeder, 1/2" EPDM	1
37		Hose Clamp, 1/2"	6
38		Hose Tank Rinse, 3/8" EPDM	1
39		Hose Tank Rinse, 3/8" EPDM	1
40		Hose Clamp, 3/8"	2

15-835 TANK RINSING SYSTEM

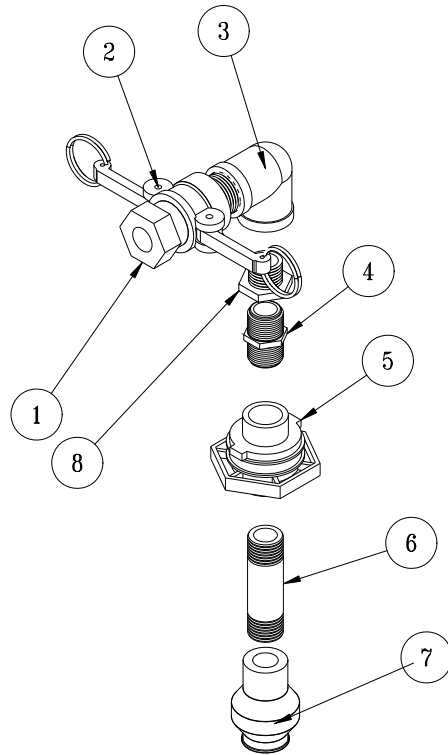

REF#	PART#	DESCRIPTION	QUANTITY
1	16-961	1" Adapter	1
2	16-962	1" Coupler	1
3	16-864	1" FTP Elbow	1
4	16-158	Close Nipple	1
5	16-150	Double Thread Fitting	1
6	16-172	4" Nipple	1
7	15-834	Tank Rinsing Nozzle	1
8	16-163	Reducer Bushing	1

Drill 1-3/4" hole 5" from outside edge of cover.

Install Tank Rinsing kit as shown, with the Double Thread Fitting (Ref 5) going into the cover.

Basket Must be removed During Use.

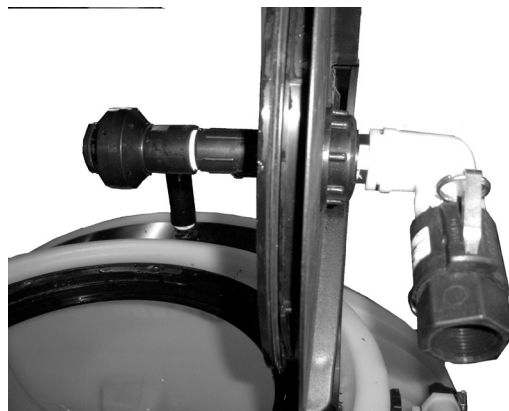

DECAL LIST

This is a list of decals located on the Spray Star 3180. Part number, description and location will help in reordering decals.

15-463 Decal, Spray Pump	Right Side Panel
16-228 Decal, Over the Road towing	Front Seat Panel
25-277 Decal, Battery Warning	Battery
25-279 Decal, Safety Warning	Belt Guard
25-286 Decal, Pinch Point	Both Sides of Seat Panel
25-298 Decal, Warning Hot	Cooler Guard, Above Muffler on Tank Side, Panel Behind
Seat	
25-321 Decal, Refuel w/ Diesel	Front Right Tank
25-356 Decal, Tire Pressure 20psi	Front Tires
25-371 Decal, Diesel	Sides of Engine Cover
25-372 Decal, 4" Star	Rear Tank, Computer Cover
25-370 Decal, 88 dBA	Panel Behind Seat
25-380 Decal, Tire Pressure 30psi	Rear Tires
27-077 Decal Smithco	Steering Wheel
27-093 Decal, Hydraulic Oil Level	Oil Tank
30-016 Decal, Spray Star 3180	Tank Sides
20-545 Decal, Dashboard	Dashboard
30-019 Decal, Site Gauge	Tank Fill Hose
30-157 Decal, Control Panel	Right Side Panel
30-117 decal, Ultra Fuel	Fuel Tank
34-147 Decal, Smithco Logo	Nose Cone

QUICK REFERENCE REPLACEMENT PARTS

REPLACEMENT FILTERS

60-215	Hydraulic Oil Filter Assembly
60-334	Oil Filter
30-042-05	Air Cleaner Cartridge
13-488	Key Switch
30-042-08	Fuel Filter Element
30-042-09	Engine Oil Filter
77-217	Exhaust Muffler Gasket

REPLACEMENT BELTS

30-137	Spray Pump Belt
--------	-----------------

SEAL KITS

15-301	Power Steering Orbital Motor
15-301-01	Seal Kit
30-101	Wheel Motors
30-101-11	Seal Kit
30-102	Hydrostatic Pump
33-058-01	Seal Kit
30-098	Gear Pump
30-098-01	Seal Kit
15-839	Hydraulic Cylinder (steering)
14-531	Seal Kit

FLUIDS

Engine Oil	SAE 10W-40 API Service SJ or higher Motor Oil
Hydraulic Fluid	SAE 10W-40 API Service SJ or higher Motor Oil
Radiator	1.06 Gal 50/50 Antifreeze/water mixture

OTHER PARTS

16-953	Hinged Cover On Tank with Gasket
16-953-01	Gasket For Cover
16-169	Strainer Basket
15-818	#75 Fitting O-ring
15-817	#50 Fitting O-ring

LIMITED WARRANTY

SMITHCO warrants this product to be free from defects in material and workmanship under normal use for one year from the date of purchase by the original user. (60 days if product is used for rental purposes.) All warranty claims must be handled through a SMITHCO authorized dealer or by SMITHCO, INC. All transportation charges must be paid by the purchaser.

There is no further express warranty. All implied warranties, including those of merchantability and fitness for a particular purpose, are limited to one year, (60 days if product is used for rental purposes) from the date of purchase by the original user, and to the extent permitted by law any and all implied warranties are excluded and disclaimed after the expiration of such period.

All incidental and consequential damages, including pickup and delivery of the unit, communication, mileage charges and/or rental of a replacement unit during repair, are not covered under this warranty, nor is any loss of income and/or other loss resulting from the failure of the product to function due to a warranty defect.

The following items are not covered under the SMITHCO warranty, and are warranted by their respective manufacturer.

- (a) Engine and engine parts, including starters, generators, alternators and filters.**
- (b) Transaxle, differentials, gear boxes and mechanical pumps.**
- (c) Hydrostatic transmissions, hydraulic pumps and motors.**
- (d) Batteries.**
- (e) Wheels and tires.**

A copy of the warranty for the above items is furnished if necessary with each SMITHCO product.

Some states do not allow limitations on how long an implied warranty lasts, or the exclusion or limitations of incidental or consequential damages, so the above limitations or exclusions may not apply to you. This warranty gives you specific legal rights and you may also have other rights, which may vary from state to state.

Federal law now requires disclosure of the warranty which applies to this product prior to the sale to a customer. Please leave this statement attached to the product and allow the buyer to remove it after purchase.

SMITHCO

Wayne, Pennsylvania 19087

