

Parts & Service



Spray Star 3180
Model 30-000-C
SN: 300G255

September 2016

Product Support:

Hwy 55 & Poplar Ave; Cameron WI 54822

1-800-891-9435 productsupport@smithco.com

CONTENTS

Introduction

Introduction.....	1-3
Introduction.....	1
General Safe Practices.....	2
Specifications	3
Optional Spray Equipment.....	3

Service

Service.....	4-11
Maintenance	4-6
Wheel Creep.....	6
Adjustments.....	7
Service Chart.....	8-9
Storage.....	10-11

Diagrams

Diagrams	12-15
Wiring Diagram.....	12-13
Hydraulic Diagram.....	14-15

Parts

Parts.....	16-53
Body & Frame	16-17
Nose Cone	18-21
Linkage.....	22-23
Front Axle	24-25
Oil Tank and Fuel Tank.....	26-27
Seat Panel.....	28-29
Engine and Pumps	30-33
Cooler and Exhaust.....	34-35
Rear Wheel Drive.....	36-37
Spray Tank.....	38-39
Turbo Quad Agitator	40-41
15-301 Orbitor	42-43
16-998 Hypro® Pump	44
76-197 Eaton Gear Pump.....	45
30-102 Hydrostatic Pump.....	46-49
30-101 Eaton Motor.....	50-51
30-099 Auburn Power Wheel®	52-53

Accessories

Reference

Accessories	54-110
Plumbing 3182 System (Raven 440)	54-55
Plumbing 3184 System (Raven 203).....	56-57
Plumbing 3185/3186 (Envizio Pro II/SharpShooter).....	58-59
Plumbing 3187/3188 (Raven 440/SharpShooter)	60-63
Controls 3182 System (Raven 440)	64-65
Controls 3184 System (Raven 203).....	66-67
Controls 3185/3186 (Envizio Pro II/SharpShooter)	68-69
Controls 3187/3188 (Raven 440/SharpShooter).....	70-71
16-524 Motorized Control Valve	72
15-737 Strainer.....	72
15-743 Manifold Ball valve	74-75
17-580 20' Heavy Duty Boom.....	76-79
17-580 Plumbing	80
17-585 Plumbing	81
17-585 18' Heavy Duty Boom.....	82-85
Triple Nozzle Assembly	86
Star Command Capstan Nozzles	87
30-010 Electric Hose Reel	88-90
30-009 Hose Reel	91
Hose Reel Installation.....	92-93
Hose Reel Adjustments	92
30-004 Foam Marker Installation.....	94-100
15-511 Foam Nozzle Sub Assembly	102
14-515 Water Meter Kit (Gallons).....	103
15-618 Water Meter Kit (Liters)	103
30-006 Fresh Water Tank	104-105
30-007 Chemical Cleanload System	106-107
15-620 Chemical Cleanload® Eductor	108-109
15-835 Tank Rinsing System.....	110
Reference	111-112
Decal List.....	111
Quick Reference Replacement Parts	112
Warranty	

Thank you for purchasing a **Smithco** product.

Read this manual and all other manuals pertaining to the Spray Star 3180 carefully as they contain safety, operating, assembly and maintenance instructions. Failure to do so could result in personal injury or equipment damage.

Keep manuals in a safe place after operator and maintenance personnel have read them. Right and left sides are from the operator's seat, facing forward.

WARNING:

Engine exhaust and some of its constituents are known to the State of California to cause cancer, birth defects, and other reproductive harm.
For more information visit
www.P65Warning.ca.gov

All **Smithco** machines have a Serial Number and Model Number. Both numbers are needed when ordering parts. Refer to engine manual for placement of engine serial number.

For product and accessory information, help finding a dealer, or to register your product please contact us at www.Smithco.com.

Information needed when ordering replacement parts:

1. Model Number of machine
2. Serial Number of machine
3. Name and Part Number of part
4. Quantity of parts

For easy access record your Serial and Model numbers here.

SMITHCO			
WAYNE, PENNSYLVANIA 19087 USA 610-688-4009 Fax 610-688-6069			
SERIAL NO.	kW/hp	DATE OF MFG.	
<input style="width: 95%; height: 20px;" type="text"/>	<input style="width: 95%; height: 20px;" type="text"/>	<input style="width: 95%; height: 20px;" type="text"/>	
MODEL NO.	lb/kg Empty	lb/kg Full	
<input style="width: 95%; height: 20px;" type="text"/>	<input style="width: 95%; height: 20px;" type="text"/>	<input style="width: 95%; height: 20px;" type="text"/>	



SAFE PRACTICES

1. It is your responsibility to read this manual and all publications associated with this machine.
2. Never allow anyone to operate or service the machine or its optional equipment without proper training and instructions. Never allow minors to operate any equipment.
3. Learn the proper use of the machine, the location and purpose of all the controls and gauges before you operate the equipment. Working with unfamiliar equipment can lead to accidents.
4. Wear all the necessary protective clothing and personal safety devices to protect your head, eyes, ears, hands and feet. Operate the machine only in daylight or in good artificial light.
5. Inspect the area where the equipment will be used. Pick up all debris you can find before operating. Beware of overhead obstructions and underground obstacles. Stay alert for hidden hazards.
6. Never operate equipment that is not in perfect working order or without decals, guards, shields, or other protective devices in place.
7. Never disconnect or bypass any switch.
8. Carbon monoxide in the exhaust fumes can be fatal when inhaled, never operate a machine without proper ventilation.
9. Fuel is highly flammable, handle with care.
10. Keep engine clean. Allow the engine to cool before storing and always remove the ignition key.
11. Disengage all drives and set park brake before starting the engine.
12. Never use your hands to search for oil leaks. Hydraulic fluid under pressure can penetrate the skin and cause serious injury.
13. This machine demands your attention. To prevent loss of control or tipping of the vehicle:
 - A. Use extra caution in backing up the vehicle. Ensure area is clear.
 - B. Do not stop or start suddenly on any slope.
 - C. Reduce speed on slopes and in sharp turns. Use caution when changing directions on slopes.
 - D. Stay alert for holes in the terrain and other hidden hazards.
14. Before leaving operator's position:
 - A. Disengage all drives.
 - B. Set park brake.
 - C. Shut engine off and remove the ignition key.
 - D. If engine has to run to perform any maintenance keep hands, feet, clothing and all other parts of body away from moving parts.
15. Keep hands, feet and clothing away from moving parts. Wait for all movement to stop before you clean, adjust or service the machine.
16. Keep the area of operation clear of all bystanders.
17. Stop engine before making repairs/adjustments or checking/adding oil to the crankcase.
18. Use parts and materials supplied by **Smithco** only. Do not modify any function or part.
19. Use caution when booms are down as they extend out beyond the center line of the machine.
20. The tank is a confined space, take precaution.

These machines are intended for professional maintenance on golf courses, sports turf, and any other area maintained turf and related trails, paths and lots. No guaranty as to the suitability for any task is expressed or implied.



SPECIFICATIONS SPRAY STAR 3180

WEIGHTS AND DIMENSIONS

Length	128" (325 cm)
Width	72" (183 cm)
Height w/ ROPS	84" (213 cm)
Height w/ Booms Folded	136" (345 cm)
Wheel Base	68" (173 cm)
Weight Empty	2340 lbs (1061 kg)
Weight Full	4950 lbs (2245 kg)

SOUND LEVEL (DBA)

At ear level	88.4 dBA
At 30 ft. (9.14 m)	77 dBA

ENGINE

Make	Kubota
Model#	V1505
Code / Spec#	1G994-0000
Horsepower	35.5 hp (26.6 kW)
Fuel (EMISSIONS)	No.1-D or No. 2-D, S500: Low Sulfur Diesel (LSD) less than 500 ppm or 0.05 wt.% No1-D or No.2-D, S15: Ultra Low Sulfur Diesel (ULSD) less than 15 ppm or 0.0015 wt.%
Cooling System	Liquid Cooled
Lubrication System	Full Pressure
Alternator	40 Amp

WHEELS & TIRE

Front: Two 22 x 11.00 x 10 Turf; 20 psi (1.4 bar)
Rear: Two 29 x 14.00 x 15 Multi-Trac; 30 psi (2.0 bar)

SPEED

Infinitely Variable	0-10 m.p.h. (0-18 kph)
---------------------	------------------------

BATTERY

Automotive type 24F - 12 volt	
BCI Group	Size 24
Cold Cranking Amps	900 minimum
Ground Terminal Polarity	Negative (-)
Maximum Length	10.25" (26 cm)
Maximum Width	6.88" (17 cm)
Maximum Height	10" (25 cm)

FLUID CAPACITY

Crankcase Oil	See Engine Manual
Fuel	7 gallon (26.5 liters)
Hydraulic Fluid	10 gallon (37.8 liters)
Radiator	1.06 gallons (4 liters)
Grade of Hydraulic Fluid	SAE 10W-40 API Service SJ or higher Motor Oil

OPTIONAL EQUIPMENT

15-618	Water Meter Kit	30-009	Manual Hose Reel
17-585	18' HD Super Boom	30-010	Electric Hose Reel
17-580	20' HD Super Boom	30-004	Foam Marker
30-006	Fresh Water Tank	15-835	Tank Rinse System
30-007	Chemical Cleanload Safe Fill	15-850	Sunshade Canopy
31-004	All Weather Top	14-515	Water Meter Kit (Gal)
17-590	Lazer-Beam Auto Boom for HD Booms	30-140	Electric Wash Tank



MAINTENANCE



CAUTION Before servicing or making adjustments to machine, stop engine and remove key from ignition.

NOTE: Use all procedures and parts prescribed by the manufacturer's. Read the engine manual before operation.

LUBRICATION

Use No. 2 General purpose lithium base grease and lubricate every 100 hours. The Spray Star 3180 has 7 grease fittings.

- A. One on the rod end of hydraulic cylinder.
- B. One on each the right and left spindles.
- C. One on the center front pivot.
- D. One on the idler arm.
- E. One on each of the pedal relays.

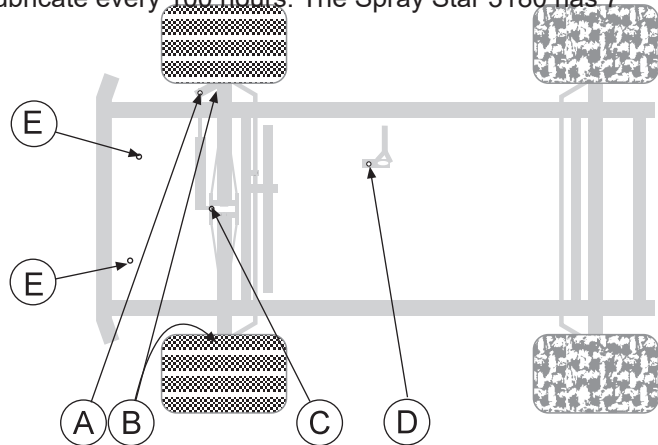

ELECTRICAL CONNECTIONS

Use dielectric grease on all electrical connections.

AIR CLEANER ON ENGINE

Since the air cleaner on this engine is a dry type, never apply oil to it.

1. Open evacuator valve (see engine manual) once a week to remove large particles of dust and dirt.
2. Wipe the inside of the air cleaner with a cloth if it gets wet or dirty.
3. Avoid touching the element except when cleaning.
4. When dust adheres to the element, gently tap element on flat surface.
5. When carbon or oil adheres to the element clean according to engine manual.
6. Replace the element every year or every 6 months.
7. **IMPORTANT** - Make sure wing bolt for the element is tight enough. If it is loose, dust and dirt may be sucked in, wearing down the cylinder liner and piston ring, resulting in poor power output.

NOTE: Do not use petroleum solvents, e.g., kerosene, which will cause cartridge to deteriorate. Do not use pressurized air to clean cartridge. Pressurized air can damage cartridge.

FUEL

CHECK EMISSION REGULATIONS OF YOUR AREA

With Emission control now in effect diesel fuel specification type and sulfur content % (ppm) used must be in compliant with all applicable emission regulations for the area in which the engine is operated.

Use of diesel fuel with sulfur content less than 0.10% (1000 ppm) is strongly recommended.

If high sulfur fuel is used, change oil and oil filters twice as often.

DO NOT USE Fuels that have sulfur content greater than 1.0% (10000 ppm).

Diesel fuels specified in EN 590 or ASTM D975 are recommended.

Since KUBOTA diesel engines of less than 56kW (75 hp) utilize EPA Tire 4 and Interim Tier 4 Standards, the use of low sulfur fuel or ultra low sulfur fuel is mandatory for these engines, when operated in US EPA regulated areas. Therefore, use No.2-D S500 or S15 diesel fuel as a alternative toe No. 2-D for ambient temperatures below -10°C (14° F).

ENGINE OIL

With strict emission control regulations now in effect, the CF-4 and CG-4 engine oils have been developed for use with low sulfur fuels, for On-Highway vehicle engines. When Non-Road engines run on high sulfur fuel, it is advisable to use a "CF or better" classification engine oil with Total Base Number (a minimum TBN of 10 is recommended).

Check the engine oil before starting or more than 5 minutes after stopping the engine. If oil level is low, remove oil filler plug and add new oil to the prescribed level. Do not overfill.

Engine oil should be MIL-L2104C or have properties of API Classifications CD grades or higher. Change the type of Engine oil according to the ambient temperature.

O= Recommended	X= Not Recommended	
Lubricating Oil Class	Fuel	
CF-4	O	X
CG-4	O	X

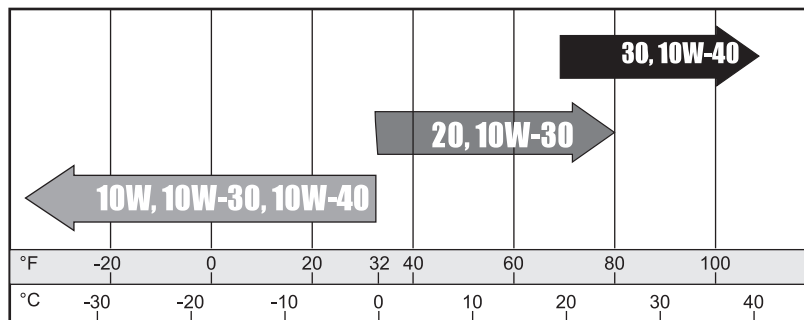

Starting Temperature Range Anticipated Before Next Oil Change

HYDRAULIC OIL

1. Use SAE 10W-40 API Service SJ or higher motor oil.
2. For proper warranty, change oil the first 50 hours and then every 500 hours or annually, which ever is first.
3. Oil level should be 2-2½" (5-6.4cm) from top of the tank when fluid is cold. Do not overfill.
4. After changing oil, run the machine for a few minutes. Check oil level and for leaks.
5. Always use extreme caution when filling hydraulic oil tank or checking level to keep system free of contaminants. Check and service more frequently when operating in extremely cold, hot or dusty conditions.
6. If the natural color of the fluid has become black or smells burnt, it is possible that an overheating problem exists.
7. If fluid becomes milky, water contamination may be a problem.
8. If either of the above conditions happen, change oil immediately after fluid is cool and find the cause. Take fluid level readings when the system is cold.
9. In extreme temperatures you can use straight weight oil. We recommend SAE 30W API Service SG when hot (above 90°F (33°C)) and SAE 10W API Service SJ or higher when cold (below 32°F (0°C) ambient temperature. Use either motor oil or hydraulic oil, but do not mix.
10. Oil being added to the system must be the same as what is already in the tank. Mark the tank fill area as to which type you put in.

TIRE PRESSURE

Caution must be used when inflating a low tire to recommended pressure. Over inflating can cause tires to explode. Front tires should be 20 psi (1.4bar) and rear tires should be 30 psi (2.0bar). Improper inflation will reduce tire life considerably.

MAINTENANCE

BATTERY

Batteries normally produce explosive gases which can cause personal injury. Do not allow flames, sparks or any ignited object to come near the battery. When charging or working near battery, always shield your eyes and always provide proper ventilation.

Battery cable should be disconnected before using "Fast Charge".

Charge battery at 15 amps for 10 minutes or 7 amps for 30 minutes. Do not exceed the recommended charging rate. If electrolyte starts boiling over, decrease charging.

Always remove grounded (-) battery clamp first and replace it last. Avoid hazards by:

1. Filling batteries in well-ventilated areas.
2. Wear eye protection and rubber gloves.
3. Avoid breathing fumes when electrolyte is added.
4. Avoid spilling or dripping electrolyte.



WARNING Battery Electrolyte is an acidic solution and should be handled with care. If electrolyte is splashed on any part of your body, flush all contact areas immediately with liberal amounts of water. Get medical attention immediately.

Use of booster battery and jumper cables. Particular care should be used when connecting a booster battery. Use proper polarity in order to prevent sparks.

TO JUMP START (NEGATIVE GROUNDED BATTERY):

1. Shield eyes.
2. Connect ends of one cable to positive (+) terminals of each battery, first (A) then (B).
3. Connect one end of other cable to negative (-) terminal of "good" battery (C).
4. Connect other end of cable (D) to engine block on unit being started (NOT to negative (-) terminal of battery)

To prevent damage to other electrical components on unit being started, make certain that engine is at idle speed before disconnecting jumper cables.

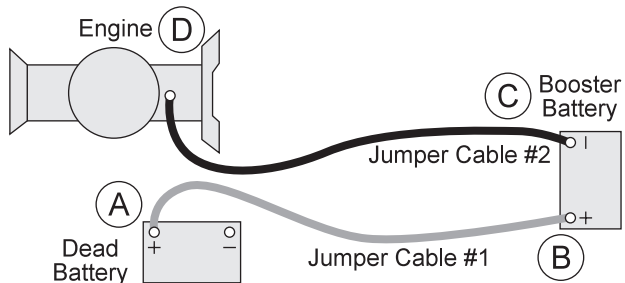

WHEEL CREEP

WHEEL CREEP

"Creep" is when the engine is running and hydrostatic transmission is in neutral, but due to inadequate alignment, wheels still move. Do the following procedure to stop this motion.

1. Lift up and support machine so rear wheels are off the ground and can turn freely.
2. In the engine compartment, the hydrostatic pump is on the right side. The shift arm (D) is on top of the pump. The idler arm (B) has a bearing that rides in the vee of the shift arm. Loosen bolt (A).
3. With engine running, move bearing (B) so it centers on the shift arm (D) and 'wheel creep' stops.
4. Tighten all fasteners and test by using foot pedal linkage to see that 'creep' is removed.
5. Turn engine off and lower machine.

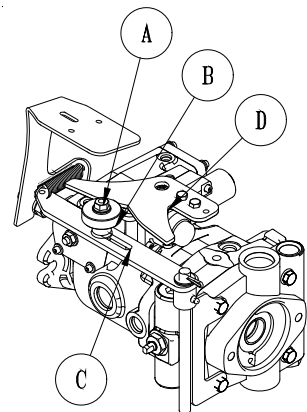

SPRAY PUMP WITH BELT

Located to the right of the engine. The belt should have approximately $\frac{1}{2}$ " (13mm) of deflection in the center of the top strand.

SAFETY INTERLOCK SWITCH

To adjust the interlock switch on the back hydrostatic pump loosen the set screw on the front half of the switch, with the ignition switch OFF. With a continuity tester connected across the switch, it should light with the shift arm centered. Move the shift arm to the right or left and the light should go off. By turning the back half of the switch clockwise it will reduce the amount of travel on the shift arm that is required for the light to remain on. The light must be on ONLY with the shift arm centered.

MASTER BOOM SWITCH (FOOT SWITCH)

The master boom switch, located on the left floorboard is used to override the master switch on the computer console of the spray systems. By pushing down it will turn on/off the booms. *For the 440 System* the Master Switch on the computer **must be off** for the master boom control switch to work.

GROUND SPEED CONTROL (FOOT SWITCH)

The ground speed control does not work the same as an automotive type cruise. The ground speed control is located on the center floorboard and is used to lock forward speed.

TO ENGAGE:

1. Flip rocker switch 'On' (green light).
2. Obtain desired speed with foot pedal.
3. Step on foot switch to lock speed.
4. Push foot switch again to disengage.

SPEED CALIBRATION NUMBERS

The speed calibration numbers for the Spray Star 3182 is 612.

SPRAY BOSS CONTROL (ORANGE)

Engages and disengages speed boss. Forward is engage and all the way back is disengage. When the lever is engaged it sets a stop for the accelerator. The accelerator pedal must be used to maintain this speed. To adjust speed use the knob on the end of the lever, counter clockwise increases speed and clockwise decreases speed. Disengage the lever and you will have full accelerator pedal range.

BRAKE RELEASE

Run machine at half-throttle minimum, prior to operating traction pedal. This will ensure proper brake release.

To disengage the brake, assemble the disengage cover with the dimple center protruding inward. This will release the brake shaft. Re-assemble the disengage cover back to its original way.

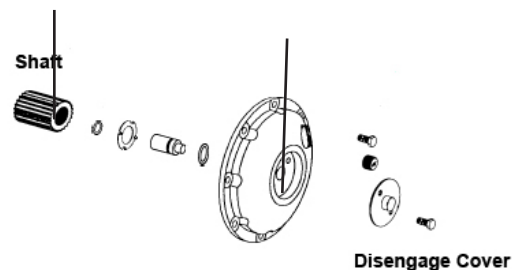

TANK AGITATION

The valve to turn on and off the tank agitation is located on the front of the seat panel, drivers right hand side. Turn valve handle down to turn on and turn back up to shut off.

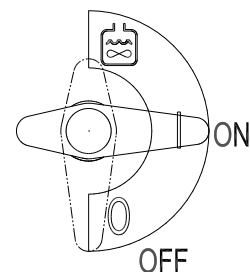

SERVICE CHART



CAUTION Before servicing or making adjustments to the machine, stop engine, block wheels and remove key from ignition.



NOTE: Follow all procedures and ONLY use parts prescribed by the manufacturer. Read the engine manual before maintenance.

The suggested maintenance checklist is not offered as a replacement for the manufacturer's engine manual but as a supplement. You must adhere to the guidelines established by the manufacturer for warranty coverage. In adverse conditions such as dirt, mud or extreme temperatures, maintenance should be more frequent.

Duplicate this page for routine use

Maintenance Check Item	For the month of _____						
	Mon.	Tues.	Wed.	Thurs.	Fri.	Sat.	Sun.
Check the Safety Seal Switch							
Check Slowing Operation							
Check the Fuel level							
Check the engine oil level							
Check the condition of the air filter							
Clean the engine cooling fan							
Check for unusual engine noises							
Check the hydraulic oil level							
Check hydraulic hoses and fittings for damage							
Check for fluid leaks							
Check the tire pressure (20-28 psi)							
Check the instrumentation							
Inspect electrical system for loose wires							
Check neutral start							
Change oil filter							
Change oil							
Lubricate Machine and Boom							
Secure all warning devices are intact							
Area of Concern _____							
Inspection Performed by _____							
Item	Date	Information					

SERVICE CHART

Item	Maintenance Procedure
At the first 20 operating hours	Torque the wheel lug nuts. (84-74 Nm (37-100 Ft-lb)) UUUUUUUUUUUU
Before each use daily	Check the engine oil level. Clean area around muffler and controls. Check the hydraulic fluid level. Check the tire pressure. Check condition of hydraulic hoses and fittings. UUUUUUUUUUUU Prove function of glow plug lines .
At the first 50 hours	Change Hydraulic Oil Filter . Change Engine oil and filter .
Every 100 hours	Clean or change air filter : P Clean fuel filter element . Lubricate machine . Check the battery fluid level and cable connections . Check fan belt tension and damage .
Every 200 hours	Check radial or hoses and clamp bands . Change engine oil : Check oil speed . UUUUUUUUUUUU Change hydraulic oil filter : Check air intake line : Torque the wheel lug nuts. (84-74 Nm (37-100 Ft-lb))
Every 500 hours or yearly	Clean Water Jacket and radiator inlets . Replace fan belt .
Every 300 hours	Check valve clearance .
Every 1500 hours	Check injection needle pressure .
Every 3000 hours	Check turbo charge . Check injection pump . Check injection timing .
Every 2 years	Change radiator coolant (L.L.C .) Replace radial or hoses and clamp bands . Replace fuel hoses and clamps . Replace intake air lines .

† In dusty conditions or when airborne dirt or is present, clean more often.

P Replace oil filter every 8 times of cleaning



STORAGE

NOTE:

To prevent damage from freezing, pour window washer fluid into spray systems tank and operate pump to circulate mix through gun and hose back to tank. Open boom control to circulate through rest of spray system.

1. Clean the exterior surfaces of the engine.
2. Change the oil and filter while the engine is still warm from operation.
3. Drain coolant from the radiator. Open cock at the bottom of the radiator, and remove the pressure cap to drain water completely. Leave the cock open. Hang a not written "No Water" on the pressure cap. Since water freezes when temperature drops below 0°C (32° F) it is important that no water is left in the machine.
4. Remove battery from the engine, adjust the electrolyte level, and recharge it. Store battery in a dry dark place.
5. Store machine in a clean, dry place.

XTENDED STORAGE

1. Check for any damaged parts or missing decals. Replace as needed.
2. Drain crankcase completely and refill with recommended engine oil or equivalent.
3. Lubricate all grease points.
4. Check coolant protection and level.
5. Clean exterior surface of engine.
6. Seal all openings in engine and accessories with non-hygroscopic material. Mask off all areas to be used for electrical contact.
7. Tape all openings and make sure all surfaces are dry. Then spray all taped openings, all engine accessories including ignition wiring, and all exterior surfaces of engine with Insulation Compound.
8. Disconnect, remove and clean battery. Check electrolyte level. Charge the battery and store in a cool dry place (NOT directly on cement).
9. Put blocks or stands under the machine to take weight off tires.

AFTER STORAGE

1. Check for any damaged parts or missing decals. Replace as needed.
2. Lubricate all grease points.
3. Clean exterior surface of engine.
4. Remove all tape and obstructions from exterior engine surfaces.
5. Charge and replace battery.
6. Check tire pressure.
7. Remove blocks or supports from under the machine.
8. Check engine oil level and coolant level and lubricate all grease points.
9. Fill fuel tank.
10. Check belt tension.
11. Run engine approximately 5 minutes before putting the engine under load.

WIRING DIAGRAM

Service

REF#	PART#	DESCRIPTION	QUANTITY
1	77-223	Timer	1
	30-042-06	Relay	1
2	50-359	Warning Light	3
3	10-556	Speedometer	1
4	12-017	Hour Meter	1
5	14-292	Seat Switch	1
6	13-488	Ignition Switch	1
7	32-014	Lights	2
8	15-725	Mount Panel End	1
	15-727	Rocker, No Light	1
	15-782	Non-Lighted Switch	1
9	15-729	Mount Panel Middle	1
	15-726	Lighted Switch	1
	15-732	Rocker, Green	1
10	15-729	Mount Panel Middle	1
	15-726	Lighted Switch	1
	15-731	Rocker, Amber	1
11	15-729	Mount Panel Middle	1
	15-727	Rocker, No Light	1
	15-728	Centering Switch, Momentary, On-Off-On	1
12	15-725	Mount Panel End	1
	15-727	Rocker, No Light	1
	15-728	Centering Switch, Momentary, On-Off-On	1

Color Code Chart

Bl	Blue
Br	Brown
Y	Yellow
G	Green
O	Orange
R	Red
B	Black
P	Purple
W	White

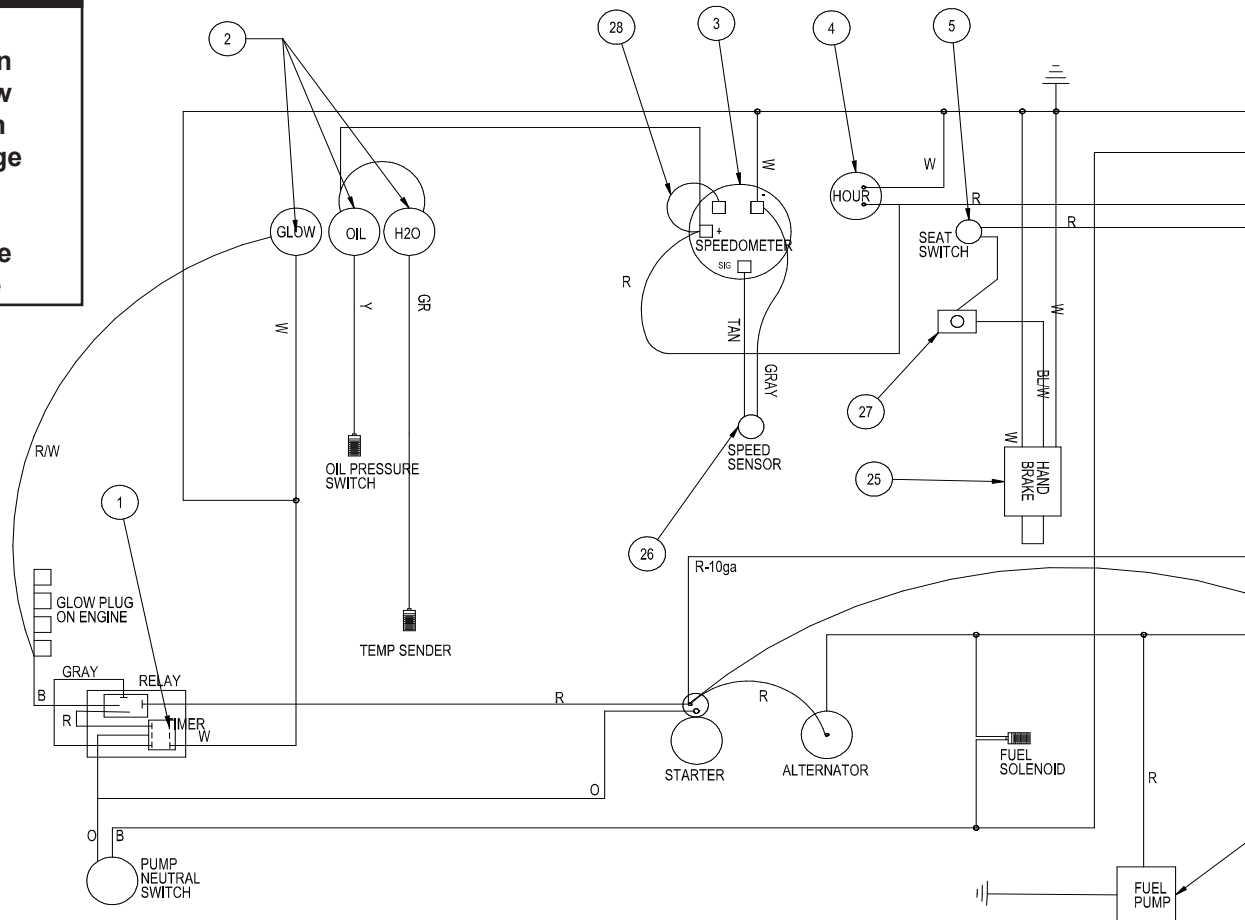

WIRING DIAGRAM

REF#	PART#	DESCRIPTION	QUANTITY
13	77-207	Buzzer	1
14	16-998	Hypro Pump	1
15	18-372	3-Way ball Valve	1
16	33-480	Pressure Switch	1
17	33-271	Buss Bar	1
	33-272	Fuse, 15 AMP	1
	33-273	Fuse, 30 AMP	2
18	33-509	Cruise Foot Switch	1
19	30-107	Wire Harness Battery ground to Fuse	1
20	33-084	Magnetic Coil	1
21	48-147	Ground Battery Cable	1
22	33-216	Battery	1
23	30-106	Wire Harness Battery to Fuse	1
24	76-326	Battery Cable	1
25	30-104	Manual Hand Brake	1
26	16-883	Speed Sensor	1
27	12-003	Park Brake Toggle Switch	1
	30-143	Toggle Switch Guard	1
28	31-071	Speedometer Wire	1
29	30-130	Fuel Pump	1
30	20-693	Circuit Breaker, 50amp	1
NA	30-148	Main Wire Harness	1
NA	30-149	Engine Wire Harness	1

Service

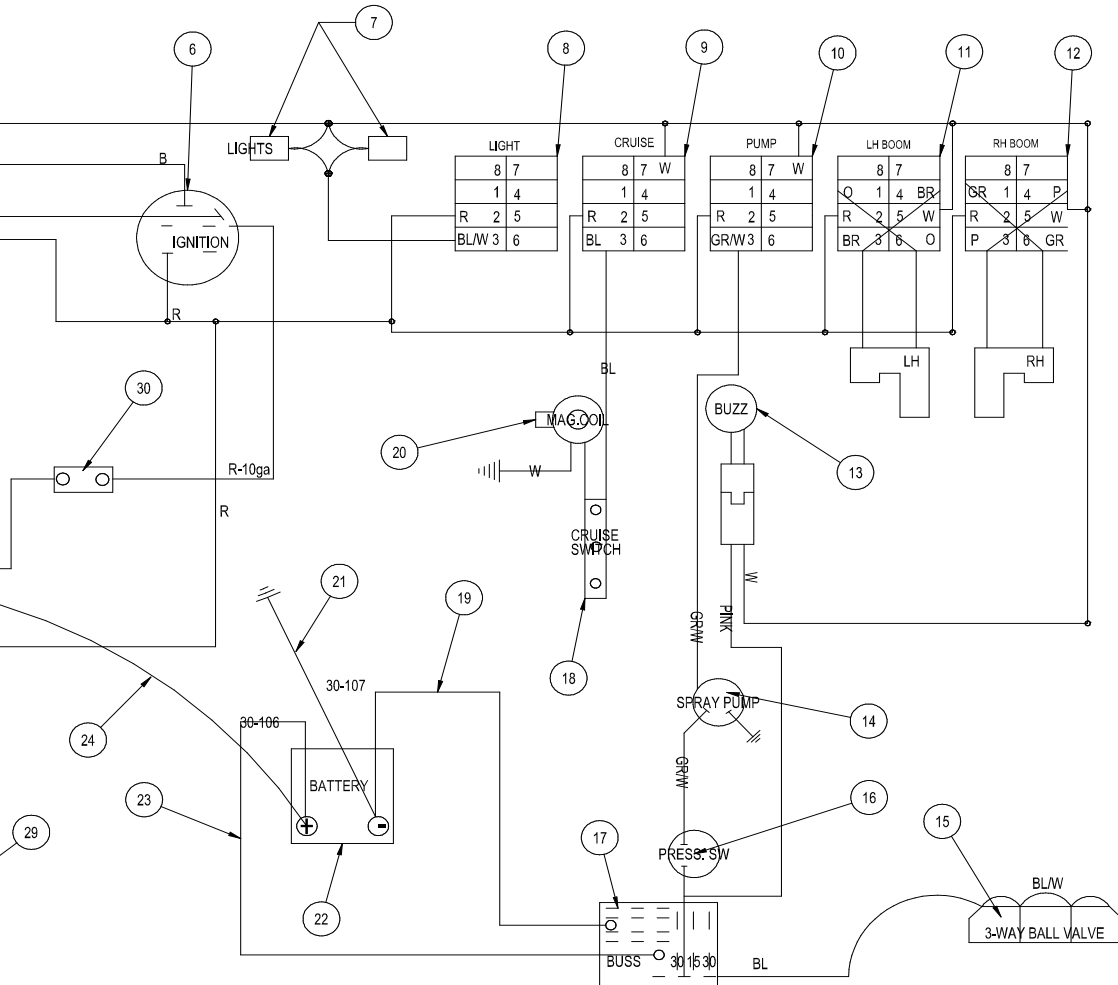

HYDRAULIC DIAGRAM

Use dielectric grease on all electrical connections.

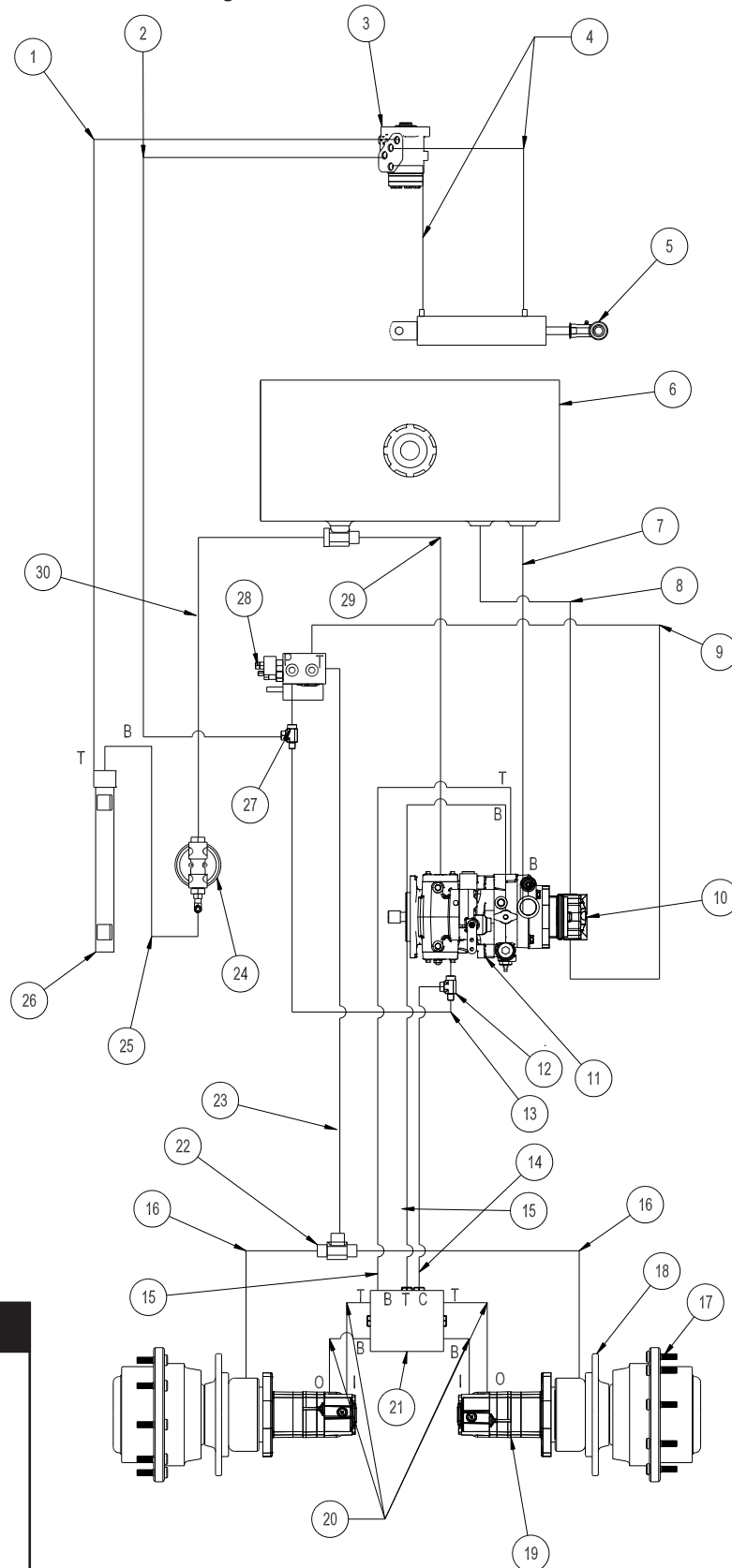

Letter Code Chart

C	Center
I	Inside
O	Outside
T	Top
B	Bottom

HYDRAULIC DIAGRAM PARTS LIST

REF#	PART#	DESCRIPTION	QUANTITY
1	30-156	Hydraulic Hose	1
2	30-091	Hydraulic Hose	1
3	15-301	Orbitrol	1
4	30-094	Hydraulic Hose	2
5	15-839	Hydraulic Cylinder	1
	14-531	Seal Kit	1
	18-171	³ / ₈ Seal Loc Adapter	2
6	30-025	Oil Tank	1
	13-747	Filler Breather	1
	13-586-03	Neck	1
7	8833-9	Suction Hose	1
	18-222	Hose Clamp	2
8	8833-17	Suction Hose	1
	18-222	Hose Clamp	2
9	30-093	Hydraulic Hose	1
10	76-197	Gear Pump	1
11	30-102	Eaton Closed Loop Pump	1
12	18-405	Run Tee	1
13	30-086	Hydraulic Hose	1
14	30-085	Hydraulic Hose	1
15	30-090	Hydraulic Hose	2
16	30-087	Hydraulic Hose	2
17	30-099	Wheel Drive	2
18	30-100	Hydraulic Release Brakes	2
19	30-101	Eaton Wheel Motors	2
20	30-089	Hydraulic Hose	4
21	30-103	Hot Oil Shuttle Manifold	1
22	18-395	Union Tee	1
23	30-088	Hydraulic Hose	1
24	60-215	Oil Filter Assembly	1
	60-334	Replacement Element	1
25	8833-41	Suction Hose	1
	18-222	Hose Clamp	2
26	30-105	Oil to Air Heat Exchanger	1
27	18-308	Swivel Tee	1
28	30-194	Brake Manifold w/ Relief	1
	30-104-01	Cartridge Valve	1
	30-104-02	Coil	1
29	8917-15.5	Suction Hose	1
	18-040	Hose Clamp	2
30	8833-24	Suction Hose	1
	18-222	Hose Clamp	2

BODY & FRAME DRAWING

Parts

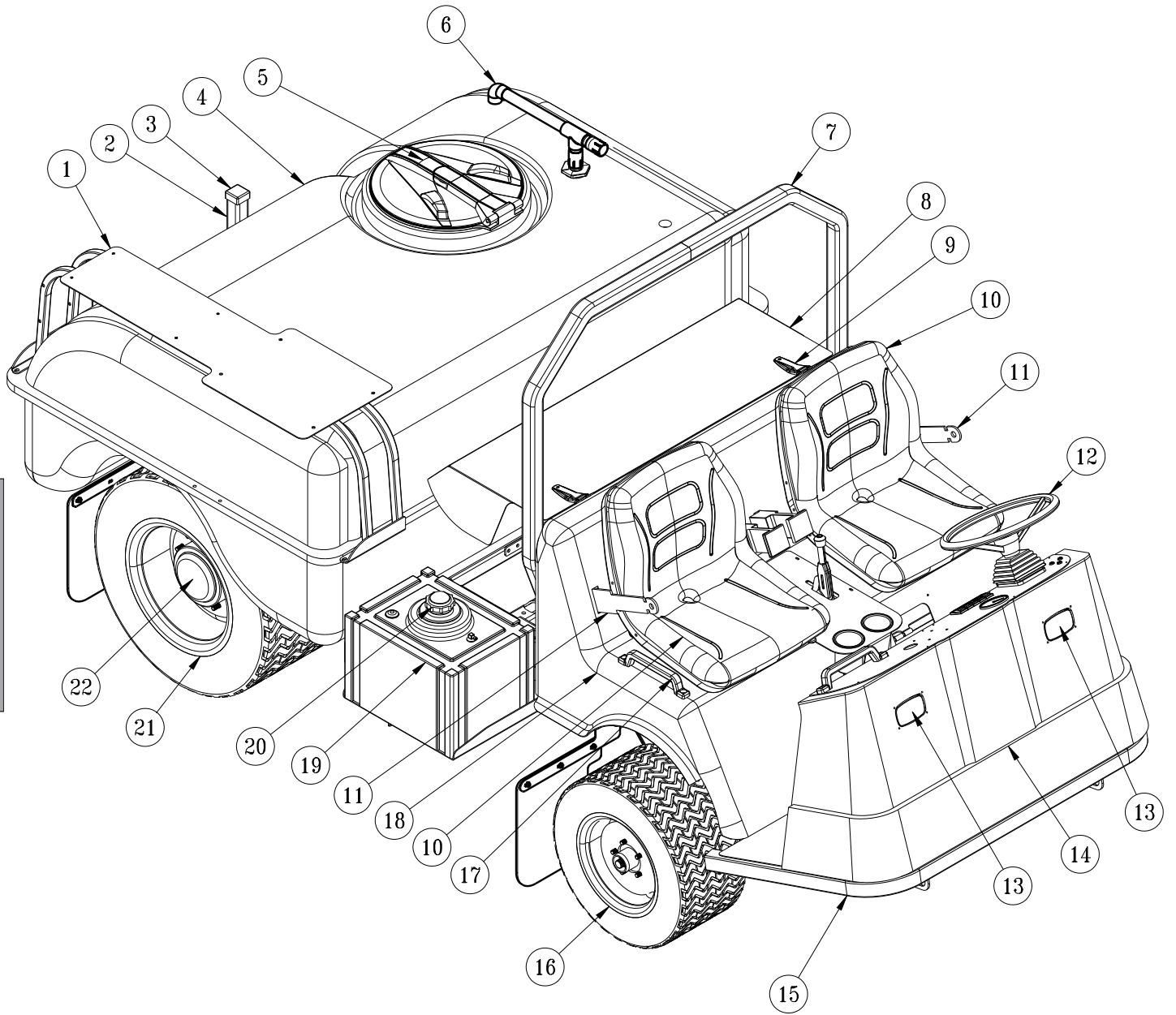

BODY & FRAME PARTS LIST

REF#	PART#	DESCRIPTION	QUANTITY
1	30-110	Accessory Mount Bracket	1
	HB-516-18-175	Bolt $\frac{5}{16}$ - 18 x $1\frac{3}{4}$	4
	HW-516	Washer $\frac{5}{16}$	4
	HNFL-516-18	Flange Lock Nut $\frac{5}{16}$ - 18	4
2	17-615	Boom Carrier	2
	HB-12-13-150	Bolt, $\frac{1}{2}$ - 13 x $1\frac{1}{2}$	4
	HNFL-12-13	Flange Lock Nut, $\frac{1}{2}$ - 13	4
3	16-557	Square Cap	2
4	30-095	318 Gallon Tank (Fiberglass)	1
	25-372	Decal, Smithco 4" Star	1
	30-016	Decal, Spray Star 3180	2
5	16-953	16" Hinged Lid Well	1
	16-953-01	Gasket for Lid	1
	16-169	Strainer Basket	1
	14-365	Air Gap Filler	1
7	31-063	Roll Bar	1
8	30-308	Engine Cover (Fiberglass)	1
9	27-055	Flush Hinge	2
	HSM 10-32-100	Machine Screw #10-32-100	12
	HNFL-10-32	Flange Whiz Lock Nut # 10 - 32	12
	10	14-270	Seat
14-292		Seat Switch	2
14-800		Seat Rail Set	2
HSP-1260-340-250		Seat Spacer	8
76-198-03		Seat Belt	2
12	13-718	15" Steering Wheel	1
	13-726	Center Cap	1
	27-077	Decal, Smithco Round	1
	32-014	Headlight	2
14	31-044	Nose Cone (Fiberglass)	1
	50-400	Grommet	1
15	30-250	Main Frame	1
16	43-124	Turf Tread Tire and Wheel	2
	43-123-01	Tire	2
	43-058-01	Wheel	2
	HNL-12-20	Lug Nut, $\frac{1}{2}$ - 20	14
17	76-443	Handle	3
18	31-045	Seat (Fiberglass)	1
19	30-262	12 Gallon Fuel Tank	1
20	30-286	Fuel Cap	1
21	30-048	Tire and Wheel(assembled)	2
	30-048-01	Tire	2
	30-048-02	Wheel	2
	HNL-12-20	Lug Nut, $\frac{1}{2}$ - 20	14
22	30-099	Wheel Drive	2

NOSE CONE DRAWING

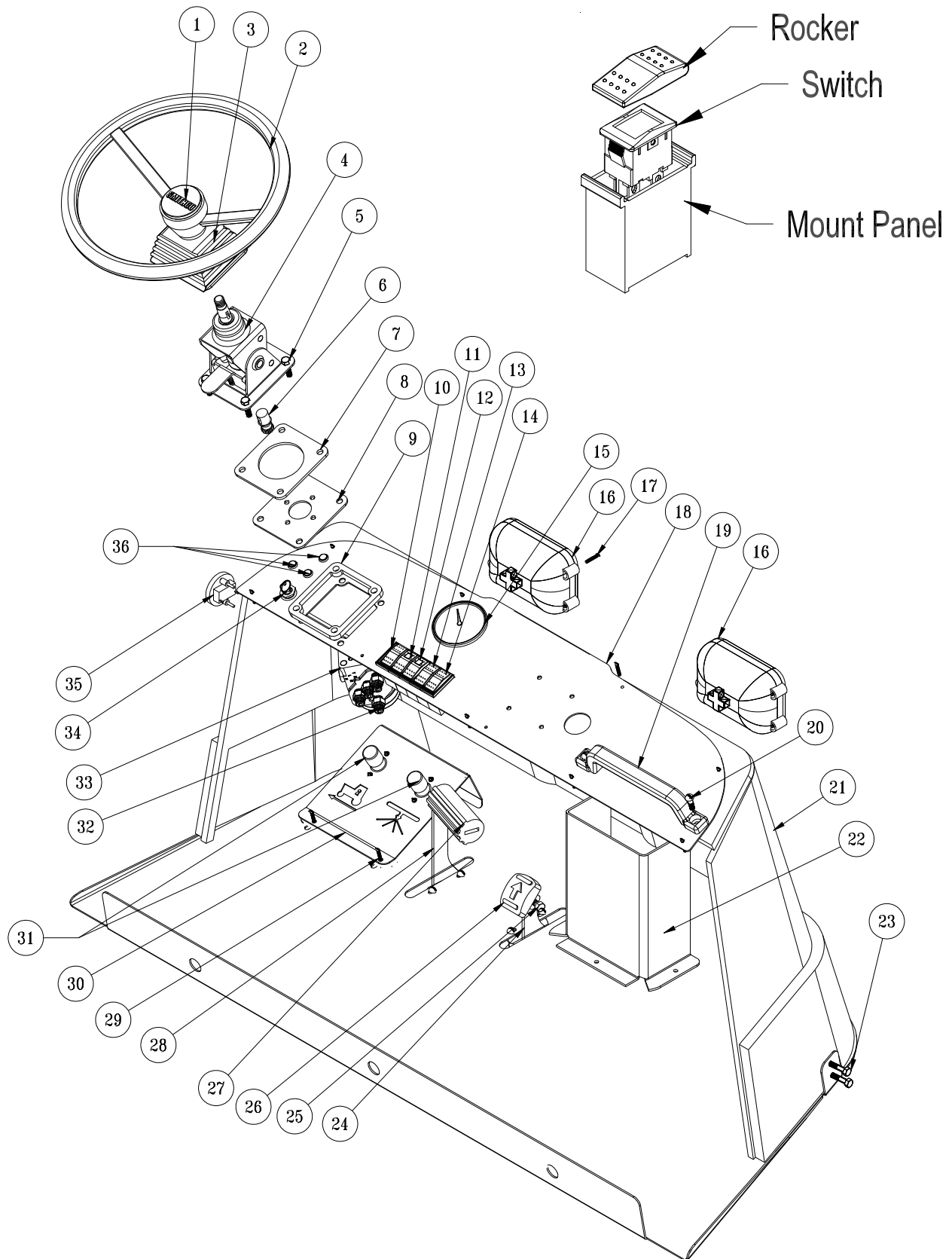

PARTS

NOSE CONE PARTS LIST

REF#	PART#	DESCRIPTION	QUANTITY
1	13-726	Center Cap	1
	27-077	Decal, Smithco Round	1
2	13-718	15" Steering Wheel	1
3	76-364	Square Boot	1
4	76-362	Mini Tilt steering	1
5	HB-516-18-125	Bolt $\frac{5}{16}$ - 18 x $1\frac{1}{4}$	4
	HNFL-516-18	Flange Whiz Lock Nut $\frac{5}{16}$ -18	4
6	48-187	Stub shaft	1
7	15-844	Tilt Steering Spacer	1
8	31-056	Tilt Steering Plate	1
9	31-057	Steering Spacer	1
10	LIGHTS		
	15-725	Mount Panel End	1
	15-727	Rocker, No Light	1
	15-782	Non-Lighted Switch	1
11	CRUISE		
	15-731	Rocker, Amber	1
	15-726	Lighted Switch	1
	15-729	Mount Panel Middle	1
12	PUMP		
	15-732	Rocker, Green	1
	15-726	Lighted Switch	1
	15-729	Mount Panel Middle	1
13	RIGHT BOOM		
	15-727	Rocker, No Light	1
	15-729	Mount Panel Middle	1
	15-728	Centering Switch, Momentary On-Off-On	1
14	LEFT BOOM		
	15-725	Mount Panel End	1
	15-727	Rocker, No Light	1
	15-728	Centering Switch, Momentary On-Off-On	1
15	10-556	Speedometer	1
16	32-014	Head Light	2
17	HSM-10-32-100	Machine Screw #10 -32 x 1	8
	HNFL-10-32	Flange Whiz Lock Nut #10 -32	8
18	20-596	Dash Panel	1
	20-545	Decal, Dash Panel	1
	HSM-10-32-100	Machine Screw #10 -32 x 1	9
	HNFL-10-32	Flange Whiz Lock Nut #10 -32	9
19	76-443	Black Handle	1
20	HSTP-516-18-100	Phillips Machine Screw $\frac{5}{16}$ -18 x 1	2
	HNFL-516-18	Flange Whiz Lock Nut $\frac{5}{16}$ -18	2
21	31-044	Nose Cone (fiberglass)	1
22	31-062	Hose Guard	1
23	HSTP-516-18-150	Phillips Machine Screw $\frac{5}{16}$ -18 x $1\frac{1}{2}$	7
	HNFL-516-18	Flange Whiz Lock Nut $\frac{5}{16}$ -18	7
24	31-050	Reverse Pedal	1
25	HB-38-16-125	Bolt $\frac{3}{8}$ -16 x $1\frac{1}{4}$	1
	HNTL-38-16	Lock Nut $\frac{3}{8}$ -16	1
26	45-022	Molded Pedal Pad	1

(Continued on next page)

NOSE CONE DRAWING

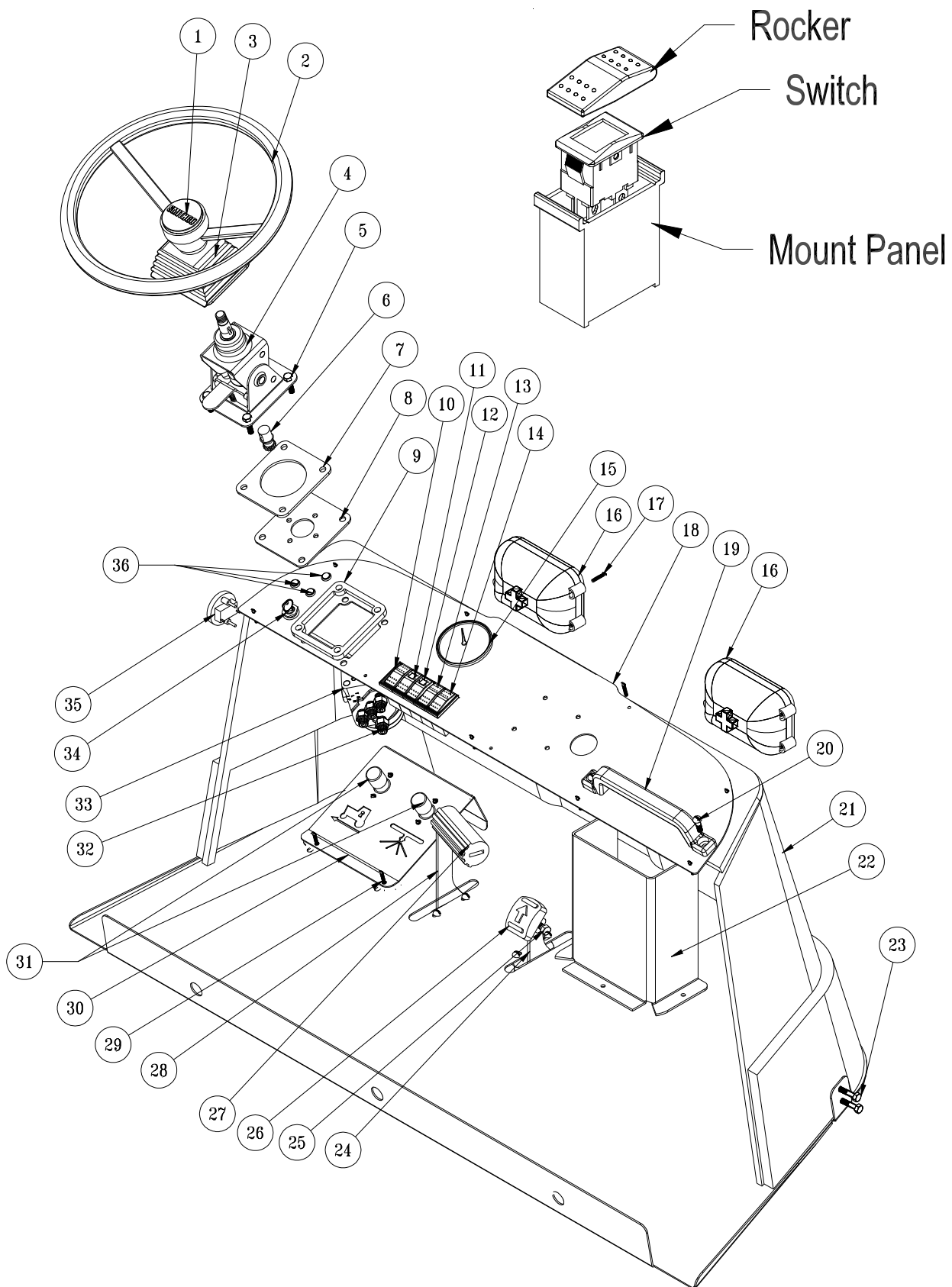

PARTS

NOSE CONE PARTS LIST

REF#	PART#	DESCRIPTION	QUANTITY
27	48-066	Pedal Grip	1
28	10-163	Forward Foot Pedal	1
29	HB-14-20-075	Bolt $\frac{1}{4}$ -20 x $\frac{3}{4}$	2
	HNFL-14-20	Flange Whiz Lock Nut $\frac{1}{4}$ - 20	2
30	31-049	Button Plate	1
31	33-509	Master Control Switch	2
	HSTP-14-20-075	Machine Screw $\frac{1}{4}$ -20 x $\frac{3}{4}$	4
32	7-867	SAE # 6 Adapter	4
33	15-301	Orbitrol	1
34	13-488	Ignition	1
35	12-017	Hour Meter	1
36	50-359	Warning Indicator Light	3

LINKAGE DRAWING

PARTS

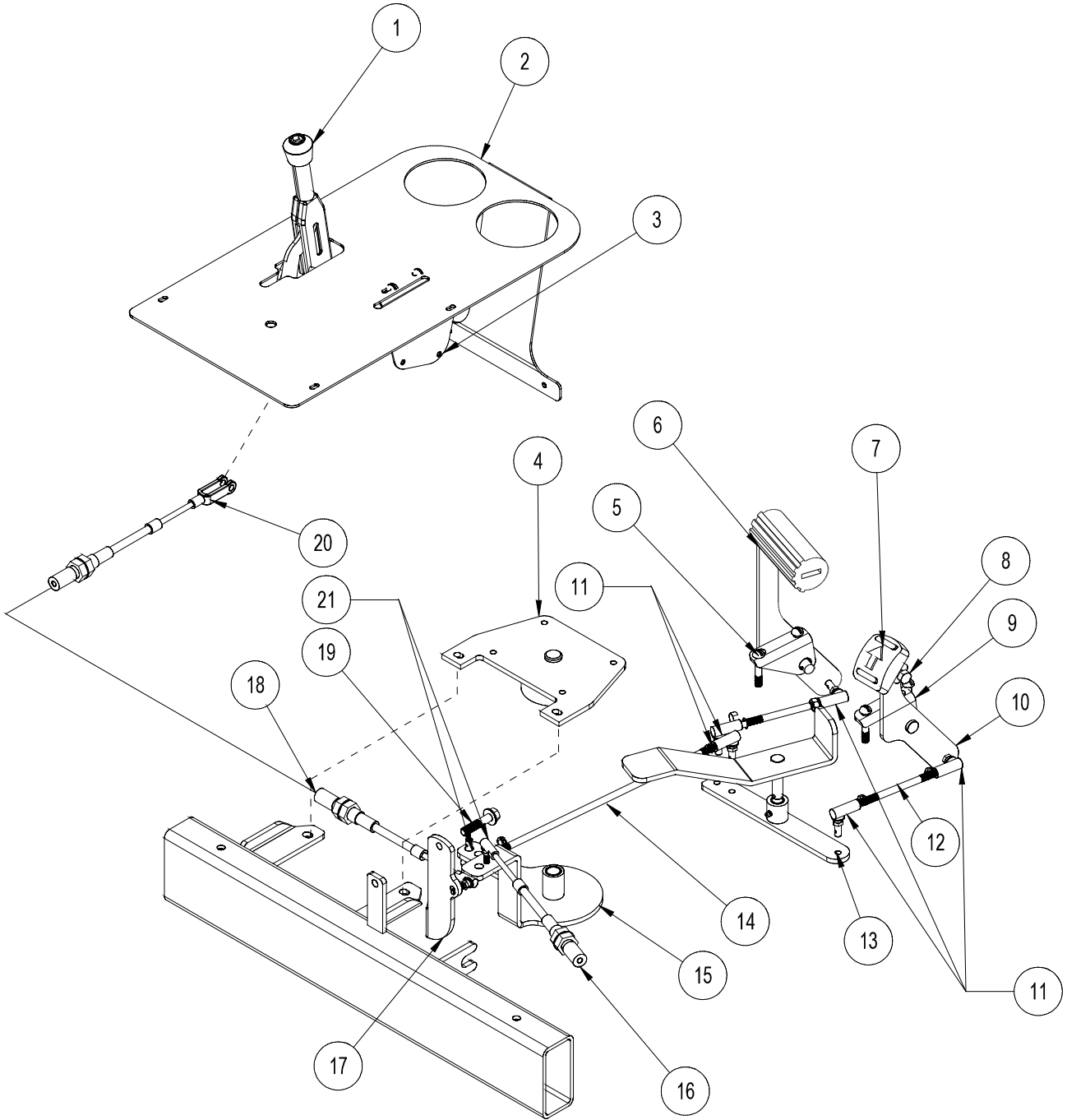

LINKAGE PARTS LIST

REF#	PART#	DESCRIPTION	QUANTITY
1	60-106	Spray Boss Control Lever	1
	34-021	Linkage Rod	1
	HN-516-24	Nut $\frac{5}{16}$ - 24	1
2	30-153	Center Console	1
3	42-766	Throttle Bracket	1
4	30-027	Relay Plate	1
5	HSTP-516-18-075	Phillips Machine Screw $\frac{5}{16}$ -18 x $\frac{3}{4}$	4
	HNFL-516-18	Flange Whiz Lock Nut $\frac{5}{16}$ -18	4
6	10-163	Forward Foot Pedal	1
	48-066	Pedal Grip	1
7	45-022	Molded Pedal Pad	1
8	HB-38-16-125	Bolt $\frac{3}{8}$ -16 x $1\frac{1}{4}$	1
	HNTL-38-16	Lock Nut $\frac{3}{8}$ -16	1
9	76-296	Pedal Mount	2
	18-234	Bushing	4
	HG-14-28-180	Grease Zerk	2
10	31-050	Reverse Pedal	1
11	21-462	Ball Joints	6
	HN-516-24	Nut $\frac{5}{16}$ - 24	6
12	31-054	Pedal Rod	2
13	10-178	Relay	1
	18-234	Bushing	2
	HG-14-28-180	Grease Zerk	1
14	31-055	Linkage Rod	1
15	15-692	Pedal Relay	1
16	13-632	Push Pull Cable	1
17	30-159	Spray Boss Arm	1
18	30-152	Push-Pull Cable	1
19	HB-516-18-100	Bolt $\frac{5}{16}$ -18 x 1	1
	HW-516	Washer	4
	HNTL-516-18	Lock Nut $\frac{5}{16}$ -18	1
20	11-103	Linkage Yoke	1
	HN-516-24	Nut $\frac{5}{16}$ - 24	1
21	8-701	Ball Joint	2
	HN-14-20	Nut $\frac{1}{4}$ - 20	2

FRONT AXLE DRAWING

PARTS

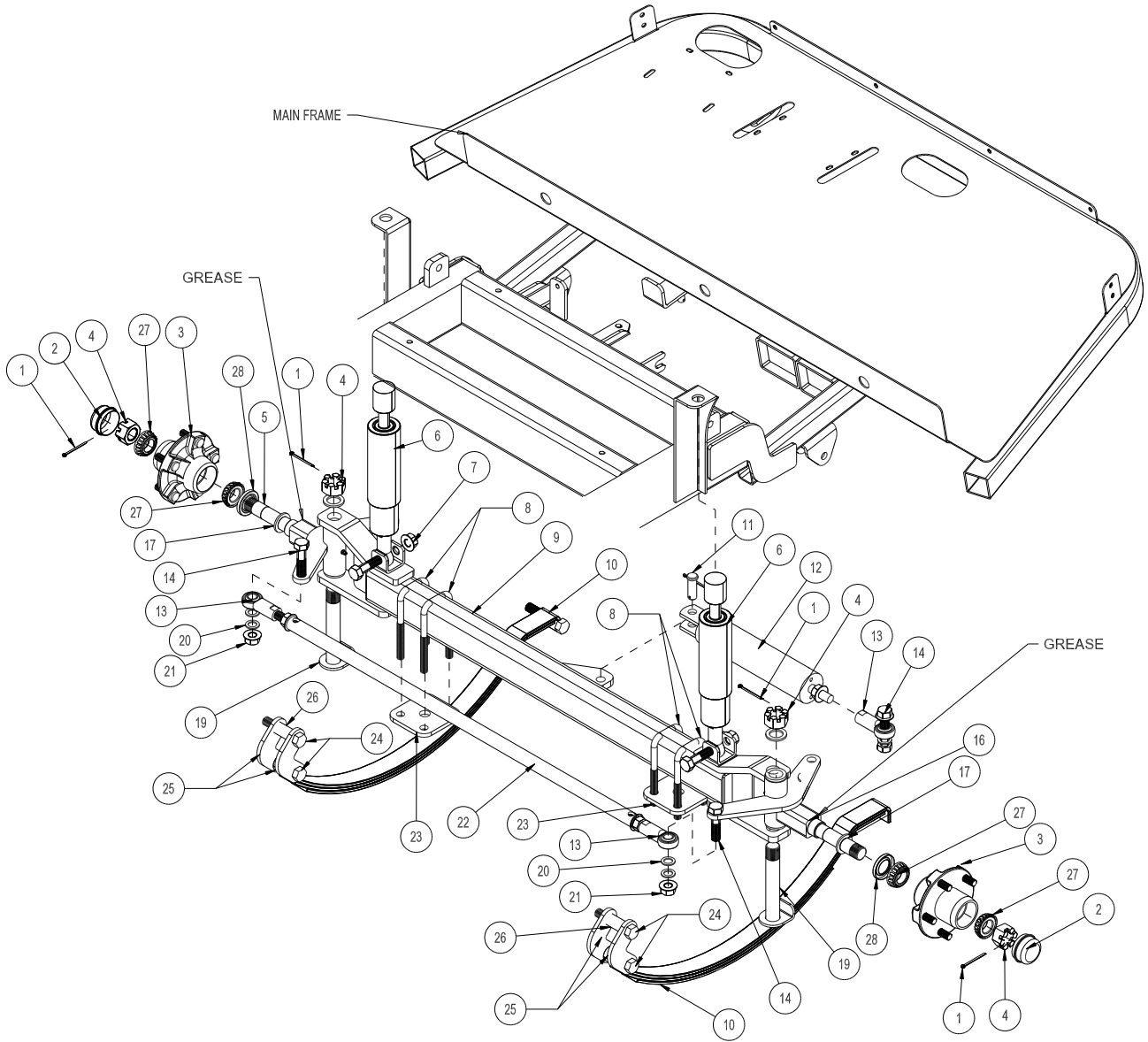

FRONT AXLE PARTS LIST

REF#	PART#	DESCRIPTION	QUANTITY
1	HP-18-150	Cotter Pin $\frac{1}{8}$ - $1\frac{1}{2}$	4
2	33-073-02	Dust Cap	2
3	30-071	Hub Assembly	1
4	HNAR-100-14	Slotted Jam Nut 1 - 14	4
5	30-070	Left Spindle	1
6	20-617	Shock Absorber	2
7	HB-58-11-300	Bolt $\frac{5}{8}$ - 11 x 3	2
	HNTL-58-11	Lock Nut $\frac{5}{8}$ -11	2
8	30-249	U-Bolt	4
	HNFL-12-13	FLange Lock Nut $\frac{1}{2}$ - 13	8
9	30-252	Front Axle	1
10	16-042	Leaf Spring	
11	HCP-58-175	Clevis Pin $\frac{5}{8}$ x $1\frac{3}{4}$	1
	HP-18-100	Cotter Pin $\frac{1}{8}$ x 1	1
12	15-839	Hydraulic Cylinder	1
	14-531	Seal Kit	1
	18-171	$\frac{3}{8}$ Seal Loc Adapter	2
13	18-154	Rod End	3
	HNJ-58-18	Jam Nut, $\frac{5}{8}$ - 18	3
	HG-14-28-90	Grease Fitting $\frac{1}{4}$ - 28 x 90°	3
14	HB-58-11-250	Bolt $\frac{5}{8}$ - 11 x $2\frac{1}{2}$	3
15	16-883	Magnetic Sensor	1
16	30-069	Right Spindle	1
17	HMB-100-10	Machine Bushing 1 x 10GA	6
18	30-072	Hub with Sprocket	1
19	16-076	King Pin	2
20	HMB-58-14	Machine Bushing $\frac{5}{8}$ x 14GA	6
21	HNTL-58-11	Lock Nut $\frac{5}{8}$ -11	3
22	30-254	Steering Link	1
23	20-538	Spring Mount	2
24	HB-916-18-325	Bolt $\frac{9}{16}$ - 18 x 3-1/4	6
	HNTL-916-18	Lock Nut $\frac{9}{16}$ -18	6
25	30-253	Spring Shackle	4
26	30-251	Bushing (pressed in main frame)	2
27	30-071-01	Bearing, Inner/Outer	2
28	30-071-02	Seal	2

OIL & FUEL TANK DRAWING

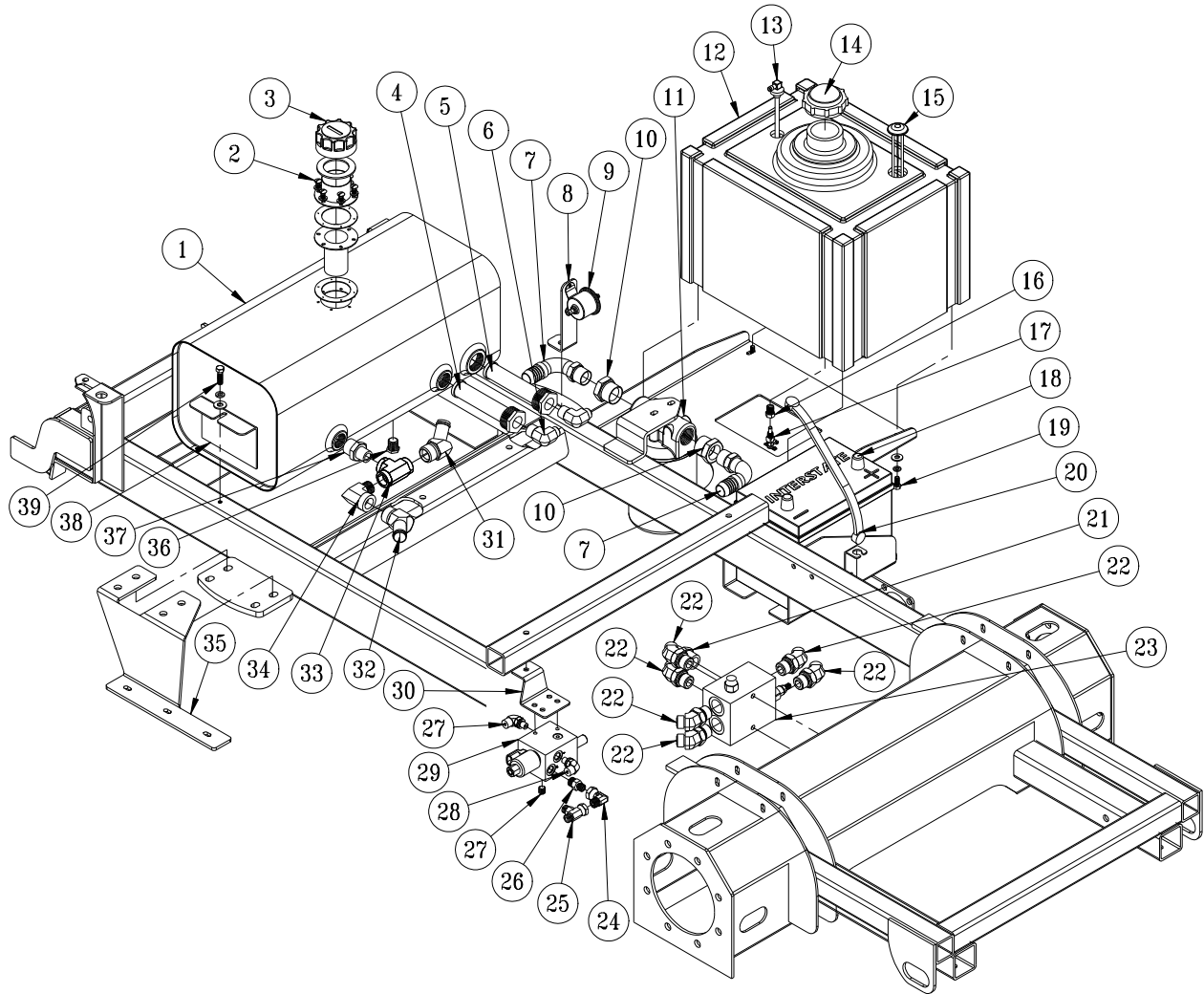

PARTS

OIL & FUEL TANK PARTS LIST

REF#	PART#	DESCRIPTION	QUANTITY
1	30-025	Oil Tank	1
2	13-586-03	Fuel Tank Neck	1
	HSM-10-32-063	Machine Screw #10-32 x $\frac{5}{8}$	6
	HWL-10	Lock Washer #10	6
3	13-747	Filler Breather	1
	13-586-01	Cap Gasket	1
	13-586-02	Bottom Gasket	1
4	18-433	Strainer	1
5	60-213	Strainer	1
6	18-398	90° Barb Fitting	2
7	18-397	90° Hose Barb Fitting	2
8	30-132	Fuel Pump Mount	1
9	30-130	Fuel Pump	1
10	18-396	Reducer	2
11	72-146	Oil Filter Assembly	1
	60-334	Replacement Filter	1
12	30-262	Fuel Tank	1
13	30-125	Top Draw Tube w/ Grommet	1
	42-814-07	Replacement Grommet	1
	9025-44	$\frac{3}{16}$ Fuel Hose 44"	1
14	30-286	Fuel Cap	1
15	31-078	Fuel Gauge w/Gasket	1
16	18-042	Reducing Bushing	1
17	15-039	Fuel Valve	1
18	33-216	Battery	1
19	HB-516-18-075	Bolt, $\frac{5}{16}$ - 18 x $\frac{3}{4}$	4
	HW-516	Flat Washer, $\frac{5}{16}$	4
	HWL-516	Lock Washer, $\frac{5}{16}$	4
20	8-603	Battery Hold Down	1
21	18-321	Straight thread Connector	1
22	18-393	Elbow	6
23	30-103	Hot Oil Shuttle Manifold	1
24	18-309	90° Elbow	1
25	18-308	Swivel Tee	1
26	18-306	Straight Thread Connector	1
27	23-126	O-ring plug	1
28	18-171	Elbow	2
29	30-194	Manifold	1
	30-104-01	Cartridge Valve	1
	30-104-02	Coil	1
30	30-209	Brake Valve Mount	1
31	18-407	$\frac{5}{8}$ 45° Hose Barb Fitting	1
32	23-190	45° Hose Barb	1
33	18-399	Tee	1
34	18-140	Elbow	1
35	30-211	Manifold Mount	1
36	18-069	Pipe Plug	1
37	18-400	Pipe Nipple	1
38	30-063	Oil Tank Hold-down	2
39	HB-38-16-125	Bolt $\frac{3}{8}$ -16 x $1\frac{1}{4}$	2
	HWL-38	Lock Washer $\frac{3}{8}$	2
	HW-38	Washer $\frac{3}{8}$	2

SEAT PANEL DRAWING

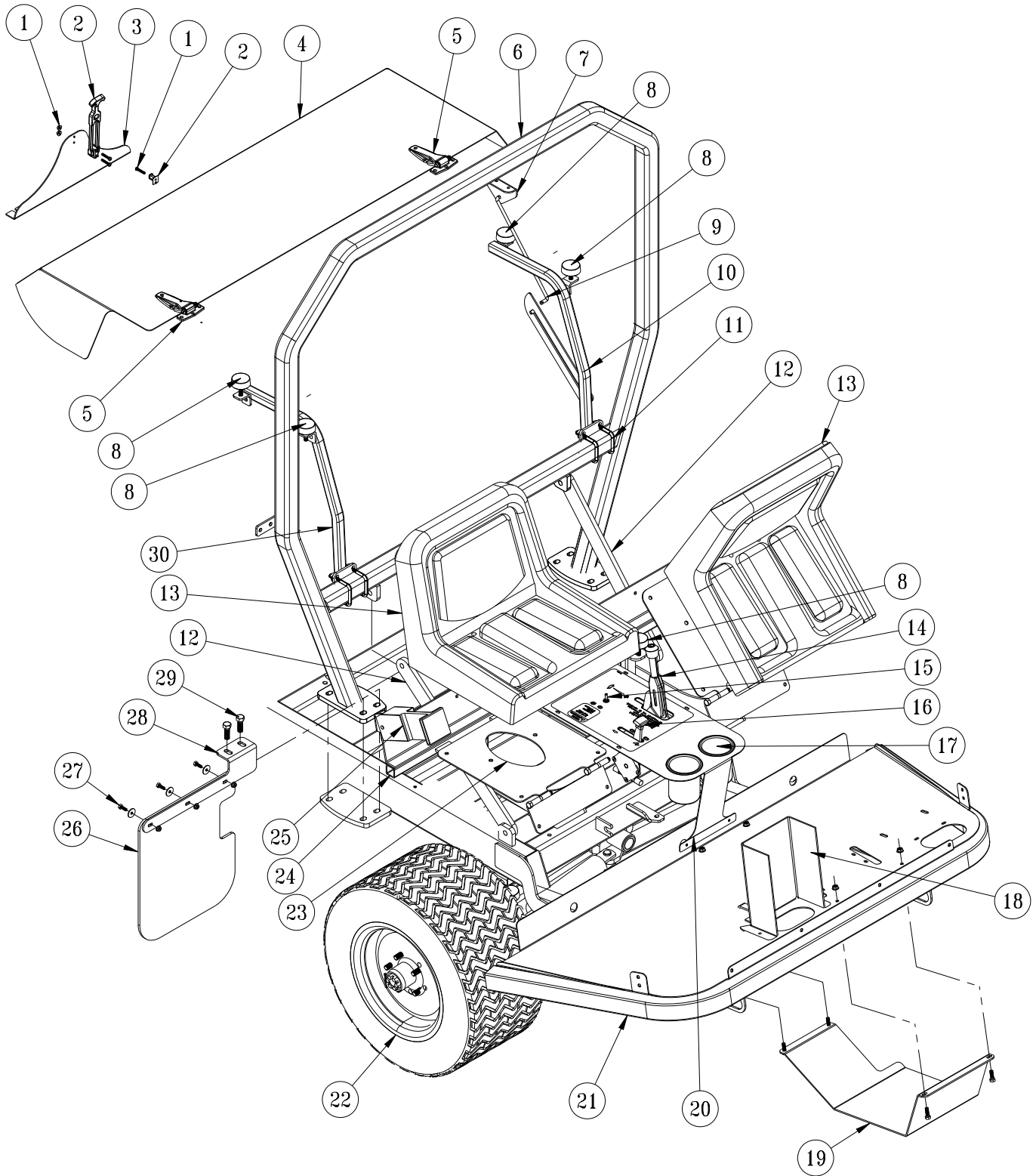

PARTS

SEAT PANEL PARTS LIST

REF#	PART#	DESCRIPTION	QUANTITY
1	HSM 10-32-112	Machine Screw #10-32 x 1 ¹ / ₈	3
	HNFL-10-32	Flange Whiz Lock Nut #10-32	3
2	15-437	Rubber Latch	1
3	30-307	Latch Mount	1
4	30-308	Engine Cover (Fiberglass)	1
5	27-055	Flush Hinge	2
	HSM 10-32-100	Machine Screw #10-32 x 1	12
	HNFL-10-32	Flange Whiz Lock Nut # 10-32	12
6	31-063	Roll Bar	1
7	31-058	Rod Pivot	1
8	50-081	Rubber Bumper	8
	HNFL-38-16	Flange Whiz Lock Nut 3 ³ / ₈ -16	8
9	31-059	Hood Rod	1
	HW-516	Washer 5 ⁵ / ₁₆	2
	HP-18-100	Cotter Pin 1 ¹ / ₈ x 1	2
10	31-065	LH Hood Support	1
11	17-537	U-Bolt	4
	HW-38	Washer 3 ³ / ₈	8
	HNFL-38-16	Flange Whiz Lock Nut 3 ³ / ₈ - 16	8
12	30-032	Roll Bar Brace	2
13	14-270	Seat	2
	14-800	Seat Rail Set	2
	HSP-1260-340-250	Seat Spacer	8
14	60-106	Park Brake Handle Kit	1
15	12-003	Toggle Switch	1
	30-143	Toggle Switch Guard	1
16	34-160	Throttle Cable	1
	42-766	Throttle Bracket	1
17	15-781	Drink Cup Holder	2
18	31-062	Hose Cover	1
19	30-288	Pedal Guard	1
	HB-516-18-100	Bolt, 5 ⁵ / ₁₆ - 18 x 1	4
	HNFL-516-18	Flange Lock Nut, 5 ⁵ / ₁₆ - 18	4
20	30-153	Center Console	1
	30-157	Decal, Console	1
21	30-250	Main Frame	1
22	43-124	Turf Tread Tire and Wheel	2
	43-123-01	Tire	2
	43-058-02	Wheel	2
23	31-052	Seat Panel	2
24	31-066	Seat Frame	1
25	76-198-03	Seat Belt	2
26	20-658	Mud Flap	2
27	HB-14-20-075	Bolt 1 ¹ / ₄ - 20 x 3 ³ / ₄	6
	HWF-14	Fender Washer 1 ¹ / ₄	6
	HNFL-14-20	Flange Lock Nut 1 ¹ / ₄ - 20	6
28	30-291	RH Front Mud Flap Bracket	1
	30-292	LH Front Mud Flap Bracket (not shown)	1
29	HB-12-13-150	Bolt 1 ¹ / ₂ - 13 x 1 ¹ / ₂	8
	HNFL-12-13	Flange Lock Nut 1 ¹ / ₂ - 13	8
30	31-064	RH Hood Support	1

ENGINE AND PUMPS DRAWING

PARTS

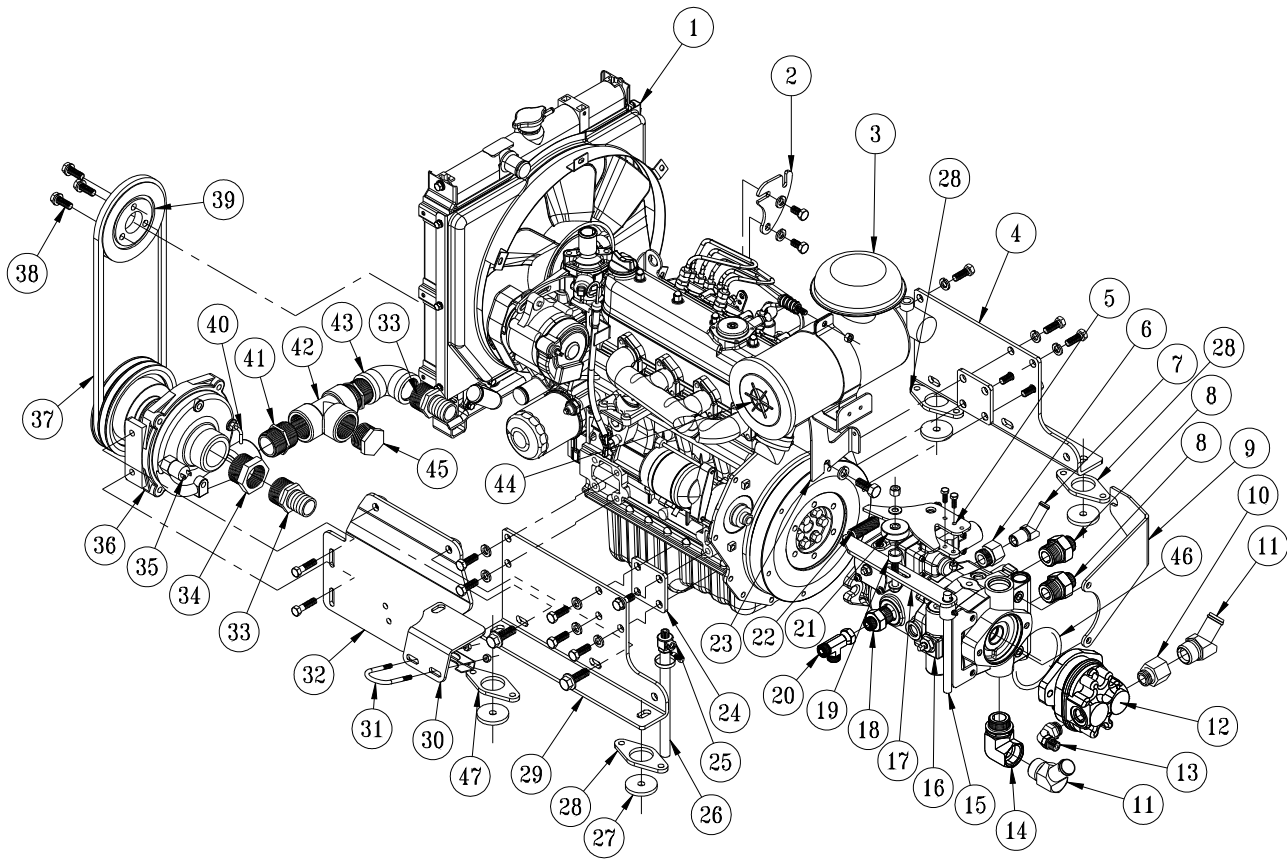

ENGINE, AND PUMPS PARTS LIST

REF#	PART#	DESCRIPTION	QUANTITY
1	30-042	Kubota Diesel Engine 33.5 HP	1
	23-145	O-Ring	1
	HW-14	Flat Washer, $\frac{1}{4}$	5
2	30-033	Throttle Cable Mount	1
	HBM-10-1.5-20	Metric Bolt, #10 - 1.5 x 20	2
	HWLM-10	#10 Lock Washer	2
3	42-004-02	Air Cleaner Cap	1
4	30-040	Engine Mount LH	1
	HBM-10-1.5-30	Metric Bolt, #10 - 1.5 x 30	6
	HWLM-10	#10 Lock Washer	6
5	30-037	Shift Arm	1
	HB-14-20-075	Bolt, $\frac{1}{4}$ - 20 x $\frac{3}{4}$	2
	HNCL-14-20	Center Lock Nut, $\frac{1}{4}$ - 20	2
6	18-333	Adapter	1
7	23-143	Connector	1
8	18-403	Adapter	2
9	30-031	Cable Mount	1
10	23-136	Straight Thread Reducer	1
11	23-190	45° Elbow, $\frac{3}{4}$ MPT	2
12	76-197	Gear Pump	1
	76-197-08	Seal Kit	1
13	18-350	Elbow, $\frac{3}{8}$	1
14	23-191	Elbow	1
15	30-029	Centering Arm Mount	1
16	30-102	Eaton Closed Loop Pump	1
17	30-082	Idler Arm	1
	HMB-12-14	Machine Bushing $\frac{1}{2}$ -14GA	
	HP-18-075	Cotter Pin $\frac{1}{8}$ x $\frac{3}{4}$	1
18	18-404	Adapter	1
19	48-049	Shift Arm Spacer	1
20	18-405	Run Tee	1
21	14-266	Ball Bearing	1
	HB-38-16-200	Bolt $\frac{3}{8}$ -16 x 2	1
	HW-38	Washer $\frac{3}{8}$	2
	HN-38-16	Nut $\frac{3}{8}$ - 16	1
22	48-109	Spring	1
23	30-036	Timer Spring Mount	1
	HB-12-13-125	Bolt $\frac{1}{2}$ - 13 x $\frac{1}{2}$	1
	HWL-12	Lock Washer $\frac{1}{2}$	1
24	30-038	Kubota Spacer	2
25	30-212	Oil Drain Valve	1
26	8810-8	Black Hose, 8"	1
	18-040	Hose Clamp	1
27	30-064	Motor Washer	4
	HB-716-14-300	Bolt, $\frac{7}{16}$ - 14 x 3	4
	HW-716	Washer, $\frac{7}{16}$	4
	HNTL-716-14	Lock Nut, $\frac{7}{16}$	4
28	30-042-01	Engine Isolator	3
	HB-38-16-100	Bolt, $\frac{3}{8}$ - 16 x 1	6
	HNFL-38-16	Flange Lock Nut, $\frac{3}{8}$ - 16	6

(Continued on Next Page)

ENGINE AND PUMPS DRAWING

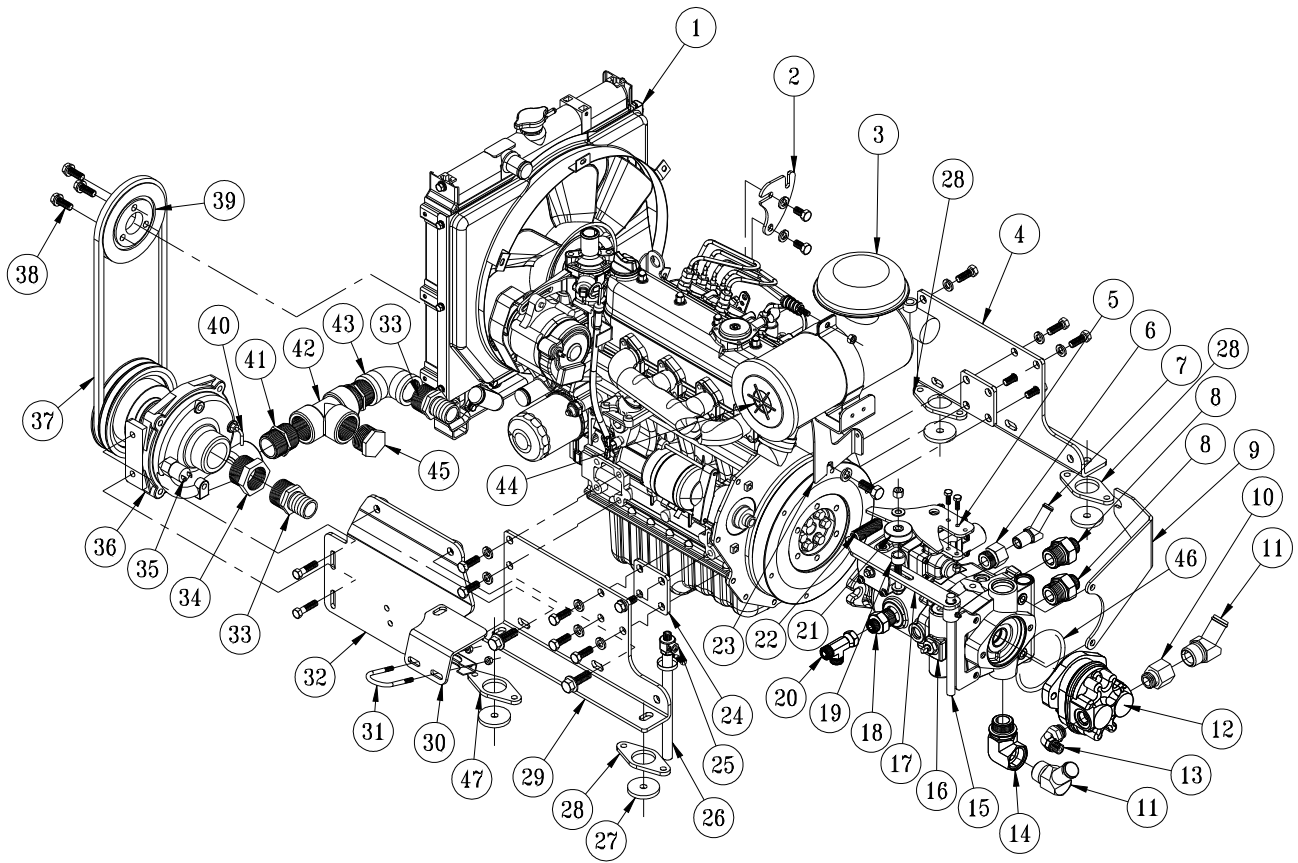

PARTS

ENGINE, AND PUMPS PARTS LIST

REF#	PART#	DESCRIPTION	QUANTITY
29	30-041	Engine Mount RH	1
	HBM-10-1.5-30	Bolt #10 - 1.5 x 30	6
	HWLM-10	#10 Lock Washer	6
30	31-042	Muffler Support	1
31	50-111	Muffler Clamp	1
32	30-207	Pump Mount	1
33	16-161	Hose Barb Fitting	2
34	16-825	Hex Bushing	1
35	33-480	Pressure Switch	1
36	16-998	Hypro Spray Pump	1
	HB-38-16-150	Bolt, $\frac{3}{8}$ -16 x $1\frac{1}{2}$	2
	HNFL-38-16	Flange Lock Nut, $\frac{3}{8}$ -16	2
37	30-197	V-Belt	1
38	HBM-10-1.25-30	Bolt #10 - 1.25 x 30	3
	HWLM-10	#10 Lock Washer	3
39	30-206	Pulley	1
40	33-494	Male Elbow	1
41	16-880	Nipple	2
42	18-390	Tee	1
43	16-182	90° Elbow	1
44	30-042-02	Air Cleaner	1
	30-042-05	Element	1
	10-389	Plug	1
45	10-389	Plug	1
46	23-145	Oring	1
47	30-042-14	515 Vibration Mount	1
	HB-38-16-100	Bolt, $\frac{3}{8}$ - 16 x 1	1
	HNFL-38-16	Flange Lock Nut, $\frac{3}{8}$ - 16	1
NS	30-042-11	Fan Belt	1
	30-042-12	Flange	1
	30-042-13	Fan Shroud	1
	30-042-17	Fuel Stop Solenoid	1

COOLER AND EXHAUST DRAWING

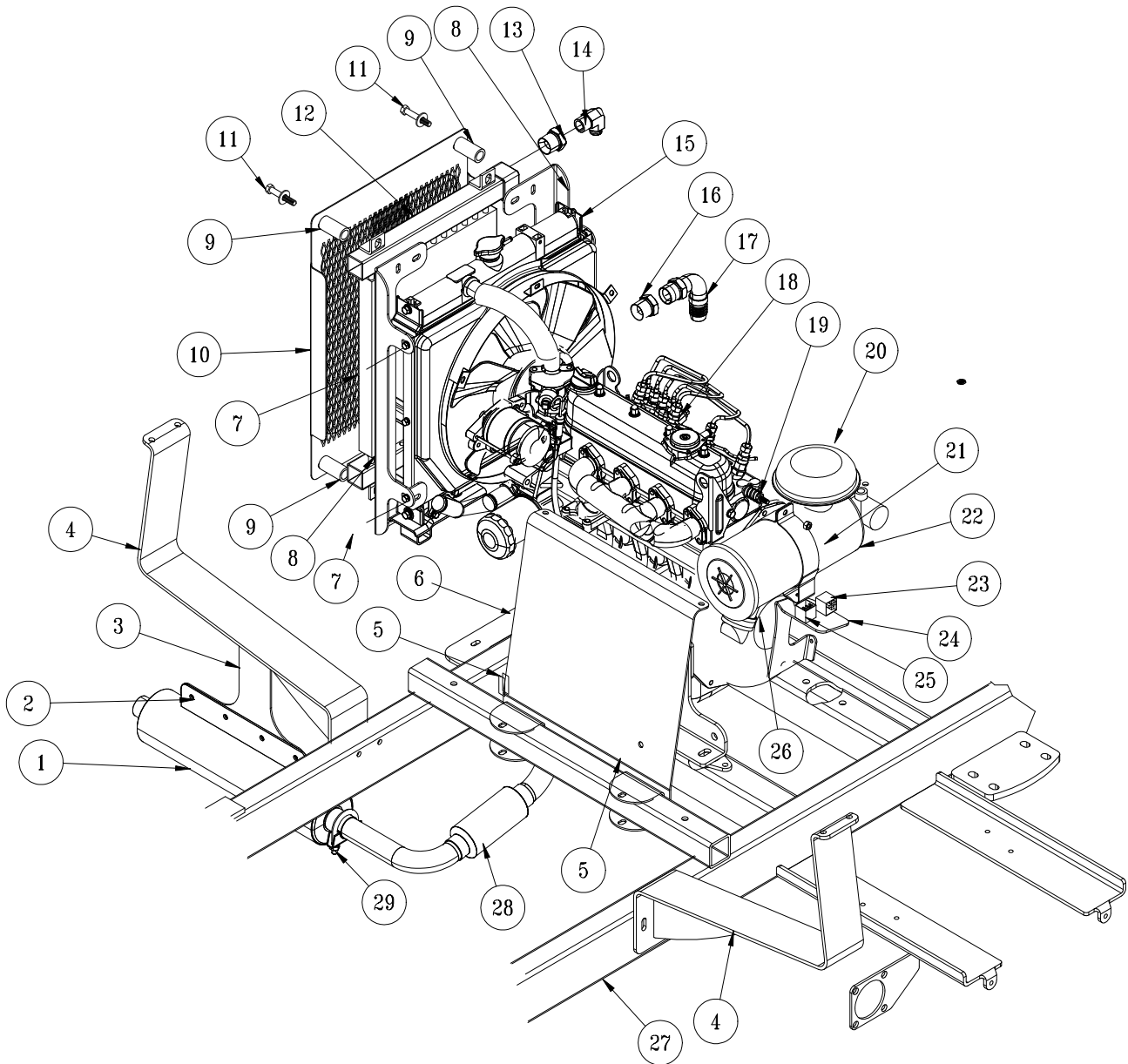

PARTS

COOLER AND EXHAUST PARTS LIST

REF#	PART#	DESCRIPTION	QUANTITY
1	30-269	Muffler with Exhaust Manifold	1
2	HBFL-516-18-075	Flange Bolt $\frac{5}{16}$ - 18 x $\frac{3}{4}$	4
	HNFL-516-18	Flange Lock Nut $\frac{5}{16}$ - 18	4
3	30-131	Muffler Hanger	1
4	30-052	Tank Carrier	2
5	HB-38-16-300	Bolt $\frac{3}{8}$ - 16 x 3	2
	HW-38	Washer $\frac{3}{8}$	2
	HNFL-38-16	Flange Lock Nut $\frac{3}{8}$ - 16	2
6	30-050	Front Tank Mount	1
7	HBM-6-1-16	Metric Bolt M6 - 1 - 16	4
	HWLM-6	Metric Washer M6	4
	HW-14	Washer $\frac{1}{4}$	4
8	30-028	Cooler Mount	2
9	60-406	Spacer	4
10	30-043	Oil Cooler Cover	1
11	HB-38-16-275	Bolt $\frac{3}{8}$ - 16 x $2\frac{3}{4}$	4
	HNFL-38-16	Flange Lock Nut $\frac{3}{8}$ - 16	4
12	30-105	Thermal Transfer Heat Exchanger	1
13	18-107	Pipe Thread Reducer	1
14	18-402	$\frac{3}{4}$ x 90° Hose Barb	1
15		Radiator	1
16	18-408	Tube End Reducer	1
17	18-397	90° Hose Barb	1
18	30-042	Kubota 33.5 HP Diesel Engine	1
19		Hardware	
20	42-004-02	Air Cleaner Cap	1
21	30-042-03	Clamp	1
22	30-042-02	Air Cleaner Body	1
	30-042-05	Element	1
	30-042-07	Inlet Hose	1
23	30-042-06	Relay (part of engine)	1
24	30-036	Timer/Spring Mount	1
25	77-223	Timer (part of engine)	1
26	30-042-04	Evacuator Valve	1
27	30-250	Main Frame	1
28	30-269	Muffler with Exhaust Manifold	1
	77-217	Exhaust Manifold Gasket	1
	48-214	Exhaust Wrap	60"
	18-222	Hose Clamp	2
29	50-111	Clamp	1

REAR WHEEL DRIVE DRAWING

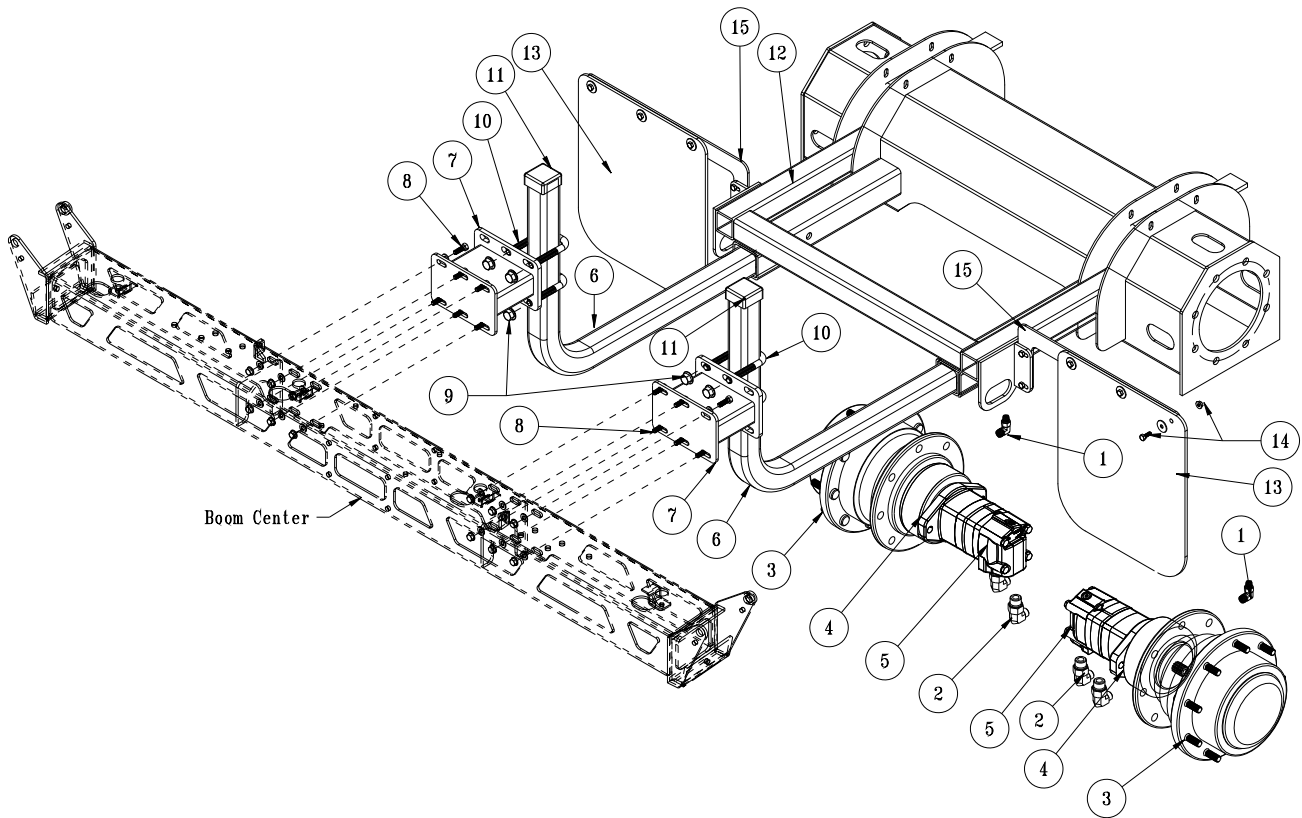

PARTS

REAR WHEEL DRIVE PARTS LIST

REF#	PART#	DESCRIPTION	QUANTITY
1	18-394	Elbow	2
2	18-301	Straight Thread Elbow	4
3	30-099	Auburn Wheel Drive	2
4	30-100	Micro Spring Hydraulic Brakes	2
5	30-101	Eaton 2000 Series Hydraulic Motor	2
	30-101-11	Seal Kit	2
6	17-615	Boom Tube	2
7	17-614	Boom Spacer	2
8	HB-516-18-100	Bolt $\frac{5}{16}$ - 18 x 1	12
	HW-516-18	Washer $\frac{5}{16}$	12
	HNFL-516-18	Flange Nut $\frac{5}{16}$ - 18	12
9	HNFL-12-13	Flange Nut $\frac{1}{2}$ - 13	8
10	20-555	U-bolt	4
11	16-557	Square Cap	2
12	30-250	Main Frame	1
13	20-657	Mud Flap	2
14	HB-14-20-075	Bolt $\frac{1}{4}$ - 20 x $\frac{3}{4}$	6
	HWF-14	Fender Washer $\frac{1}{4}$	6
	HNFL-14-20	Flange Nut $\frac{1}{4}$ - 20	6
15	30-290	Rear Mud Flap Bracket	2
	HB-516-18-100	Bolt, $\frac{5}{16}$ - 18 x 1	4
	HNFL-516-18	Flange Nut $\frac{5}{16}$ - 18	4

TANK DRAWING

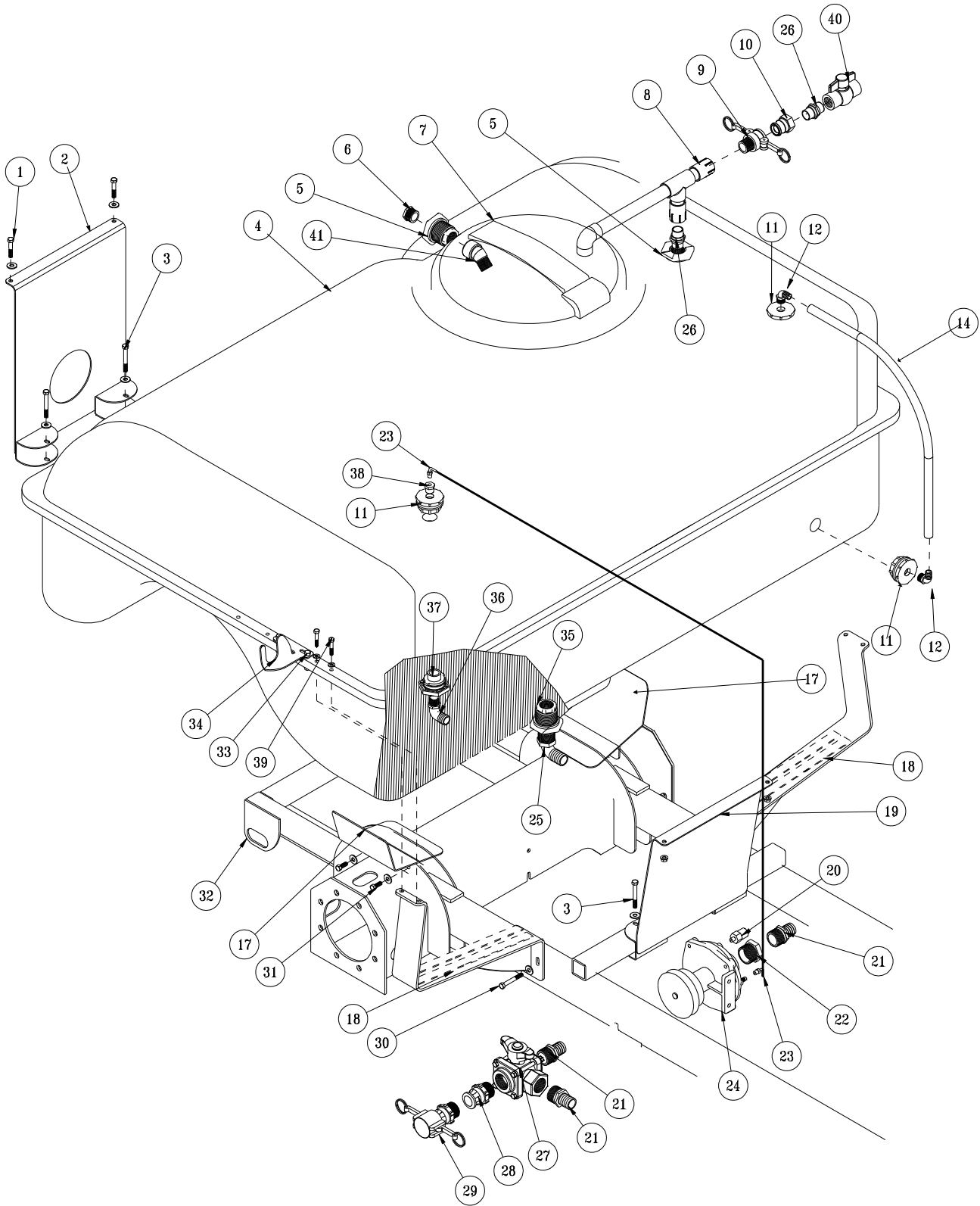

PARTS

TANK PARTS LIST

REF#	PART#	DESCRIPTION	QUANTITY
1	HB-38-16-200	Bolt $\frac{3}{8}$ - 16 X 2	4
	HW-38	Washer $\frac{3}{8}$	4
	HNFL-38-16	Lock Nut $\frac{3}{8}$ - 16	4
2	30-051	Rear Tank Mount	1
	8828-16	Foam Tape	1
3	HB-38-16-300	Bolt $\frac{3}{8}$ - 16 x 3	4
	HW-38	Washer $\frac{3}{8}$	4
	HNFL-38-16	Flange Lock Nut $\frac{3}{8}$ - 16	4
4	30-095	318 Gallon Tank (fiberglass)	1
5	16-945	Double Thread Fitting	2
6	16-162	Hex Plug 1" (Inside tank below air gap filler)	2
7	16-953	Hinged Lid Well	1
	16-953-01	Gasket for Cover	1
	16-169	Strainer Basket	1
8	14-365	Air Gap Filler	1
9	16-962	1" Coupler	1
10	16-961	1" Adapter	1
11	33-495	Bulkhead Fitting	3
12	16-937	Elbow	2
14	8902-28	Clear Flo Tubing	1
	30-019	Decal, Site Gauge	1
17	30-062	Rear Tank Support	2
	30-166	Tank Pad	2
18	30-052	Tank Carrier	2
	8828-26	Foam Tape	4
19	30-050	Front Tank Mount	1
	8828-16	Foam Tape	1
20	33-480	Pressure Switch	1
21	16-161	Fitting	3
22	16-825	Hex Bushing	1
23	33-494	Male Elbow	2
	8954-44	Clear Hose	1
	18-116	Hose Clamp	2
24	16-998	Hypro Pump	1
25	16-156	Elbow	2
26	16-851	1" Close Nipple	1
27	18-372	3-Way Valve	1
	18-372-01	Handle	1
28	16-180	Quick Coupler Male	1
29	16-935	Quick Coupler Cap	1
30	HB-38-16-275	Bolt $\frac{3}{8}$ - 16 x $2\frac{3}{4}$	4
	HW-38	Washer $\frac{3}{8}$	4
	HNFL-38-16	Flange Lock Nut $\frac{3}{8}$ - 16	4
31	HB-38-16-100	Bolt $\frac{3}{8}$ - 16 x 1	4
	HW-38	Washer $\frac{3}{8}$	4
	HNFL-38-16	Flange Lock Nut $\frac{3}{8}$ - 16	4
32	30-250	Main Frame	1
33	HB-38-16-150	Bolt $\frac{3}{8}$ - 16 x $1\frac{1}{2}$	4
	HW-38	Washer $\frac{3}{8}$	4
	HNFL-38-16	Flange Lock Nut $\frac{3}{8}$ - 16	4
34	30-034	Right Boom Holder (17-503 & 15-493 Booms Only)	1
	30-035	Left Boom Holder (17-503 & 15-493 Booms Only)	1
35	16-194	Anti-Vortex Fitting	1
36	16-155	Elbow	1
37		Double Thread Fitting (part of tank)	1
38	33-496	Reducer Bushing	1
39	HB-38-16-150	Bolt $\frac{3}{8}$ - 16 x $1\frac{1}{2}$	4
40	18-448	1" Ball Valve	1
41	16-971	45° Elbow (inside tank)	1
NS	20-663	Tank Lid Gasket	

TURBO-QUAD AGITATOR DRAWING

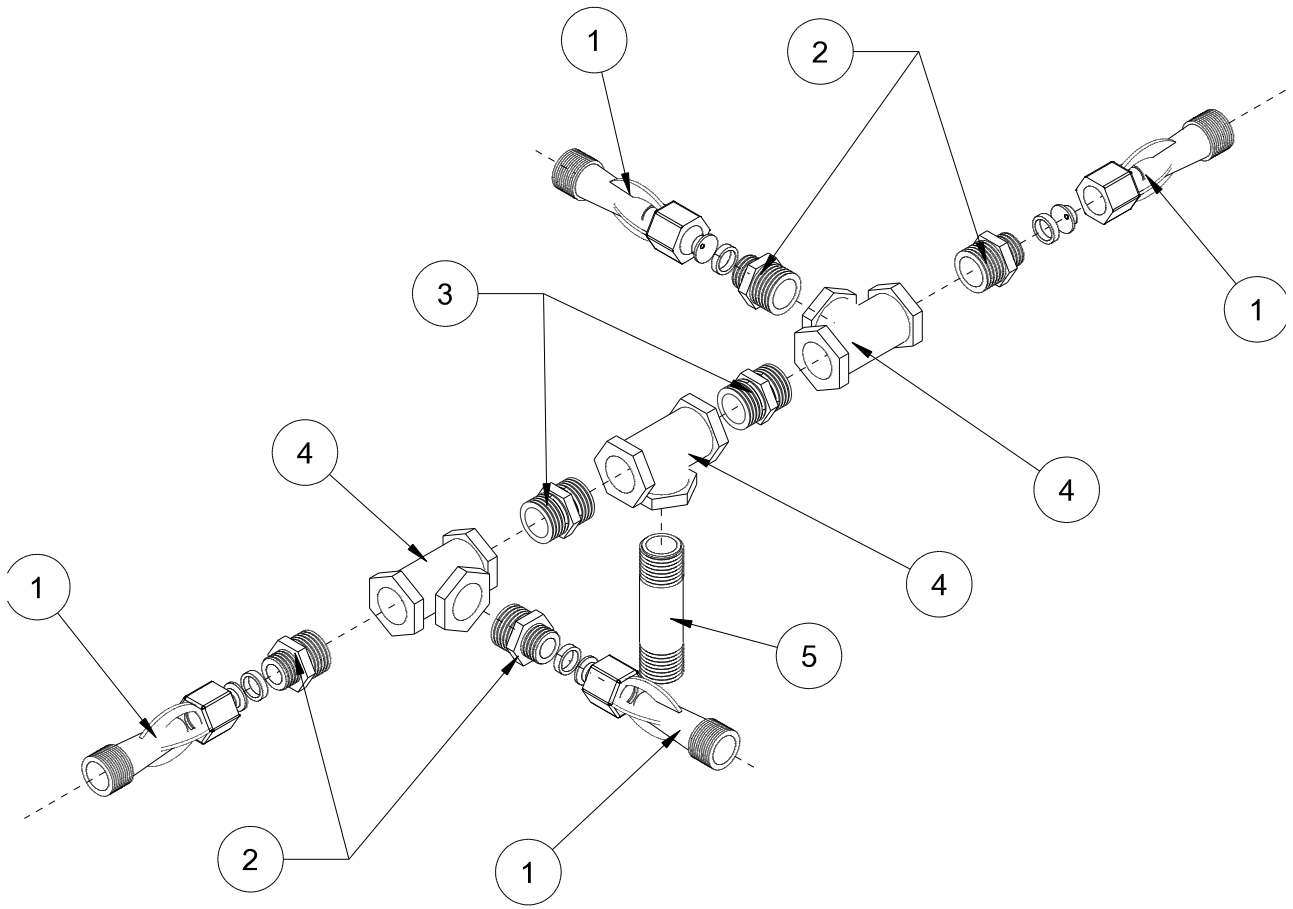

PARTS

TURBO-QUAD AGITATOR PARTS LIST

REF#	PART#	DESCRIPTION	QUANTITY
1	16-036	Agitator Jet (Includes one each $\frac{1}{8}$ " , $\frac{5}{53}$ " , and $\frac{3}{16}$ " orifices)	4
2	16-173	Reducer $\frac{3}{4}$ x $\frac{1}{2}$	4
3	16-158	Close Nipple $\frac{3}{4}$ x $\frac{3}{4}$	2
4	16-157	Female Pipe Thread Tee $\frac{3}{4}$ x $\frac{3}{4}$ x $\frac{3}{4}$	3
5	16-172	Nylon Nipple $\frac{3}{4}$ NPT x $3\frac{1}{2}$	1

15-301 ORBITROL DRAWING

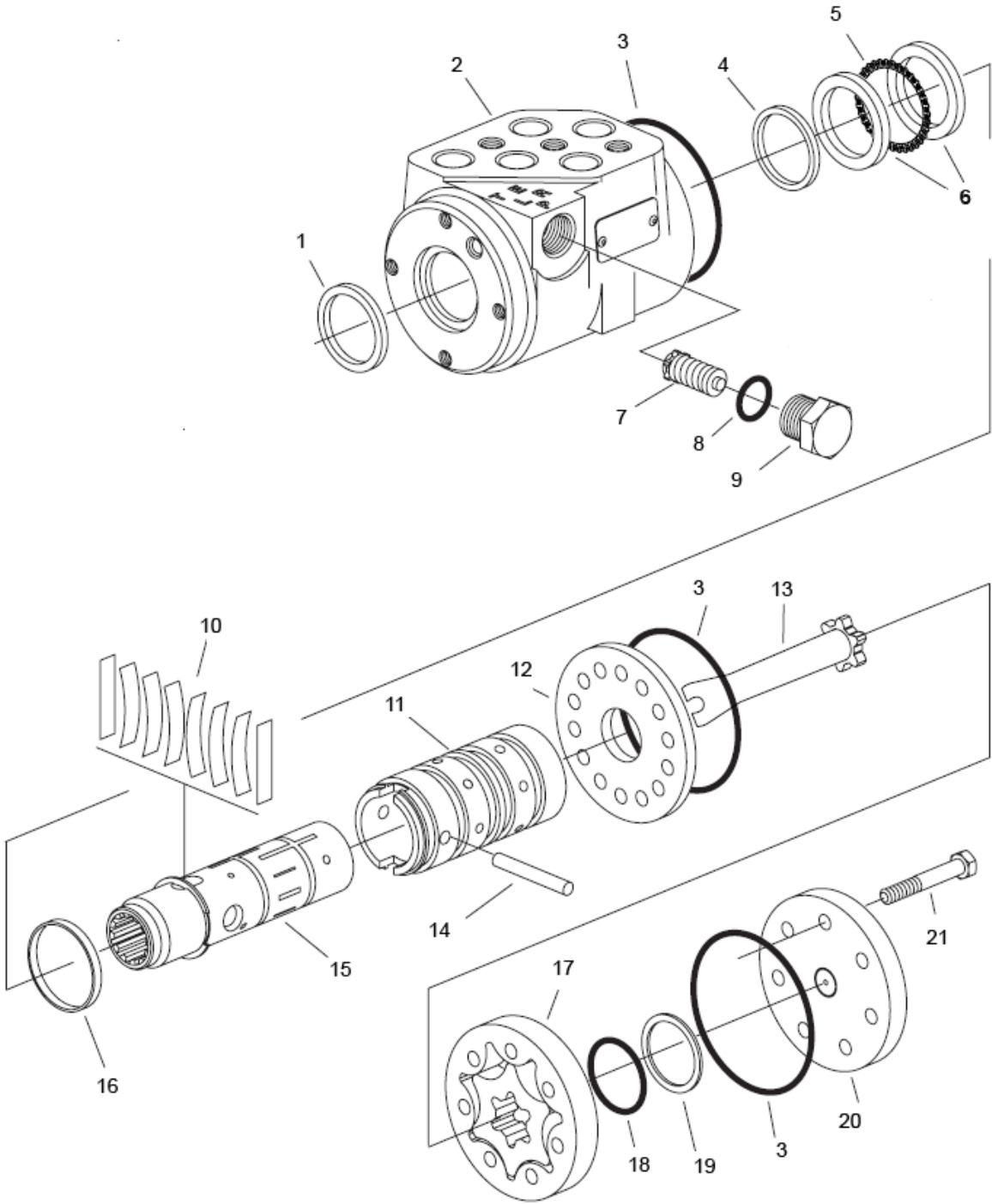

PARTS

15-301 ORBITROL PARTS LIST

REF #	PART #	DESCRIPTION	QUANTITY
1	10-576-04	Dust Seal	1
2		Housing	1
3**		O-Ring Seal	3
4**		Quad Seal	1
5	10-576-03	Thrust Bearing	1
6	10-576-02	Bearing Race	2
7		Manual Steering Relief Valve	1
8**		O-ring	1
9		Plug	1
10‡		Standard Torque Centering Springs	1
11		Sleeve	1
12	15-301-06	Wear Plate	1
13	10-576-01	Drive	1
14	15-301-08	Drive Pin	1
15		Spool	1
16‡		Spring Retaining Ring	1
17	10-576-05	Gerotor	1
18**		O-Ring	1
19**		Seal Ring	1
20	15-301-03	End Cap	1
21	10-576-06	Cap Screw	7
**	15-301-01	Seal Kit	1
‡	15-301-15	Centering Spring Kit	1

15-301 ORBITROL SPECIFICATIONS

Inlet Relief Valve Setting	1020 psi (70 bar)
Nominal Flow	3 gpm (11 lpm)
Displacement	4.50 cu. in/ R (73.8 cu cm/R)
Check Valve for Manual Steering	Yes
Inlet Pressure Rating	2030 psi (140 bar)
Return Pressure Rating	145 psi (10 bar) Maximum
Fluid	SAE 10W-40 API Service SJ or higher Motor Oil
Ports	$\frac{9}{16}$ - 18 SAE O-Ring 4 Ports

16-998 HYPRO[®] PUMP

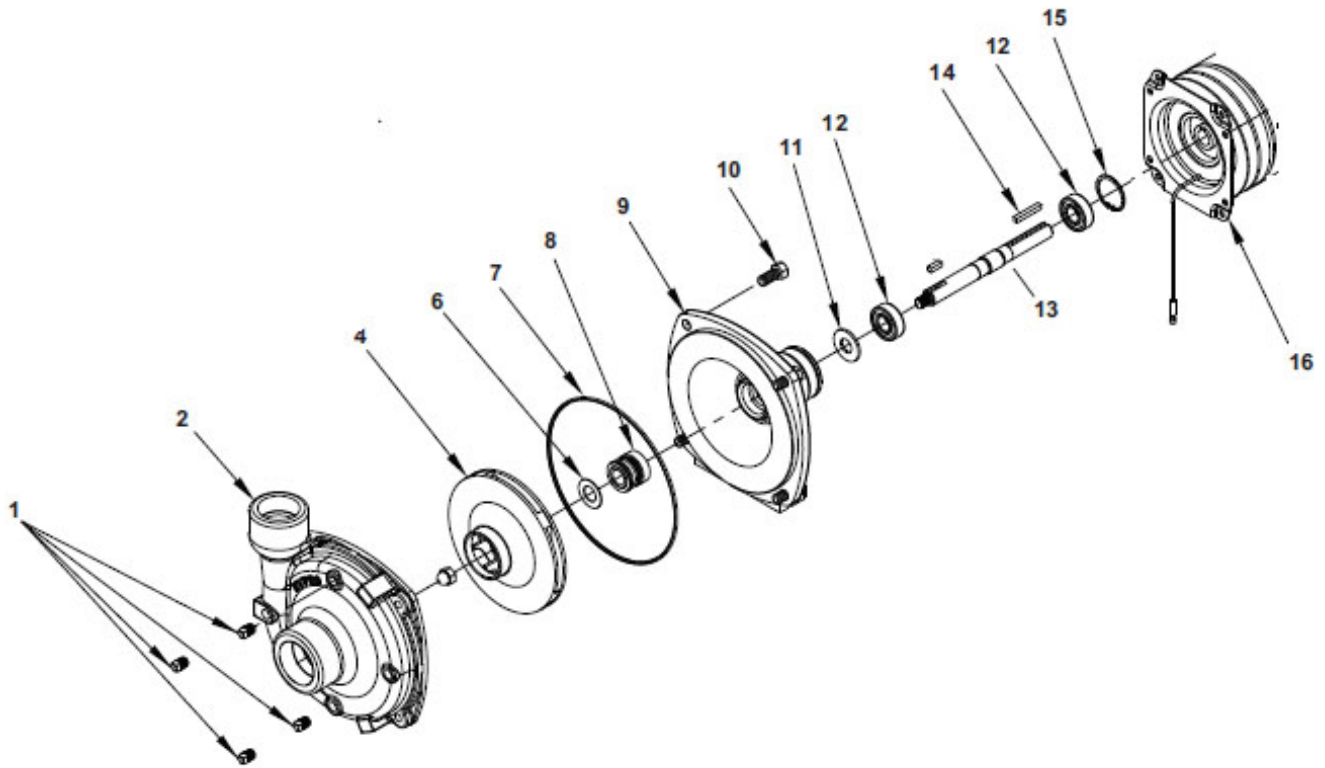

PARTS

REF#	PART#	DESCRIPTION	QUANTITY
1	16-998-01	Drain Plug	4
2	16-998-02	Pump Casing	1
4	16-966-16	Impeller	1
6	16-998-10	Gasket	1
7*	16-998-04	O-Ring	1
8*	16-998-05	Mechanical Seal (Silicon Carbide)	1
9	16-998-06	Mounting Flange	1
10	16-998-07	Bolt	
11	16-966-06	Slinger Ring	1
12	16-966-10	Ball Bearing	2
13	16-998-09	Pump Shaft	1
14	16-822-20	Key	1
15	16-966-13	Bearing Retainer	1
16	16-994-01	Clutch	1
	16-998-12	Pump Only	
*	16-967	Silicone - Carbon Seal Kit	

NOTE:

When servicing the spray pump or filter, all control valves must be shut off if there is liquid in the tank.

76-197 EATON GEAR PUMP

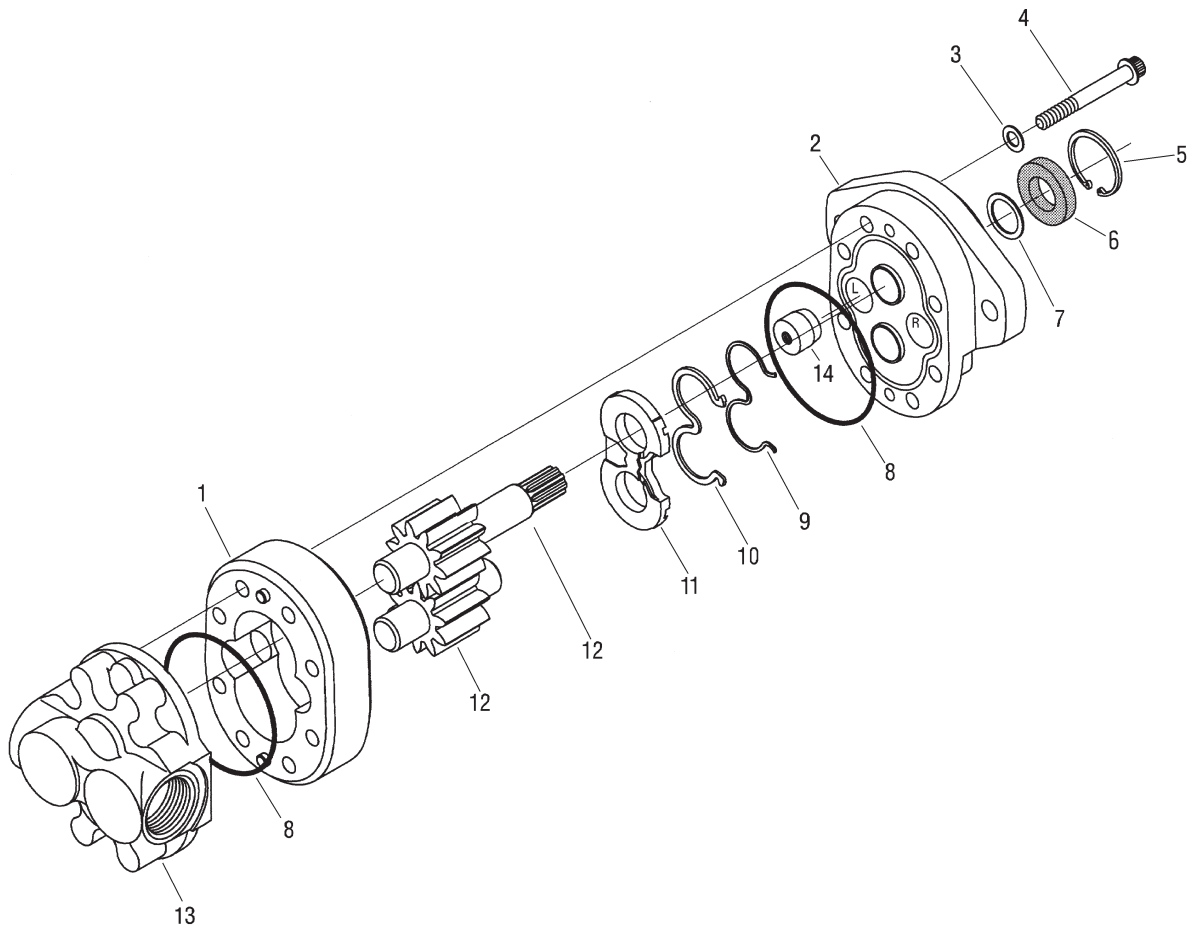

REF#	PART#	DESCRIPTION	QUANTITY
1		Body	1
2	76-197-01	Front Plate	1
3*		Washer	4
4	76-197-06	Cap Screw	8
5	76-197-07	Retaining Ring	1
6*		Shaft Seal	1
7	33-061-15	Washer	1
8*		O-Ring	2
9*		Backup Gasket	1
10*		Seal	1
11*		Wear Plate	1
12	76-197-04	Shaft (comes with Idler Gear)	1
13	76-197-02	Back Plate	1
14*		Plug	1
*	76-197-08	Seal Kit	

30-102 EATON PUMP DRAWING

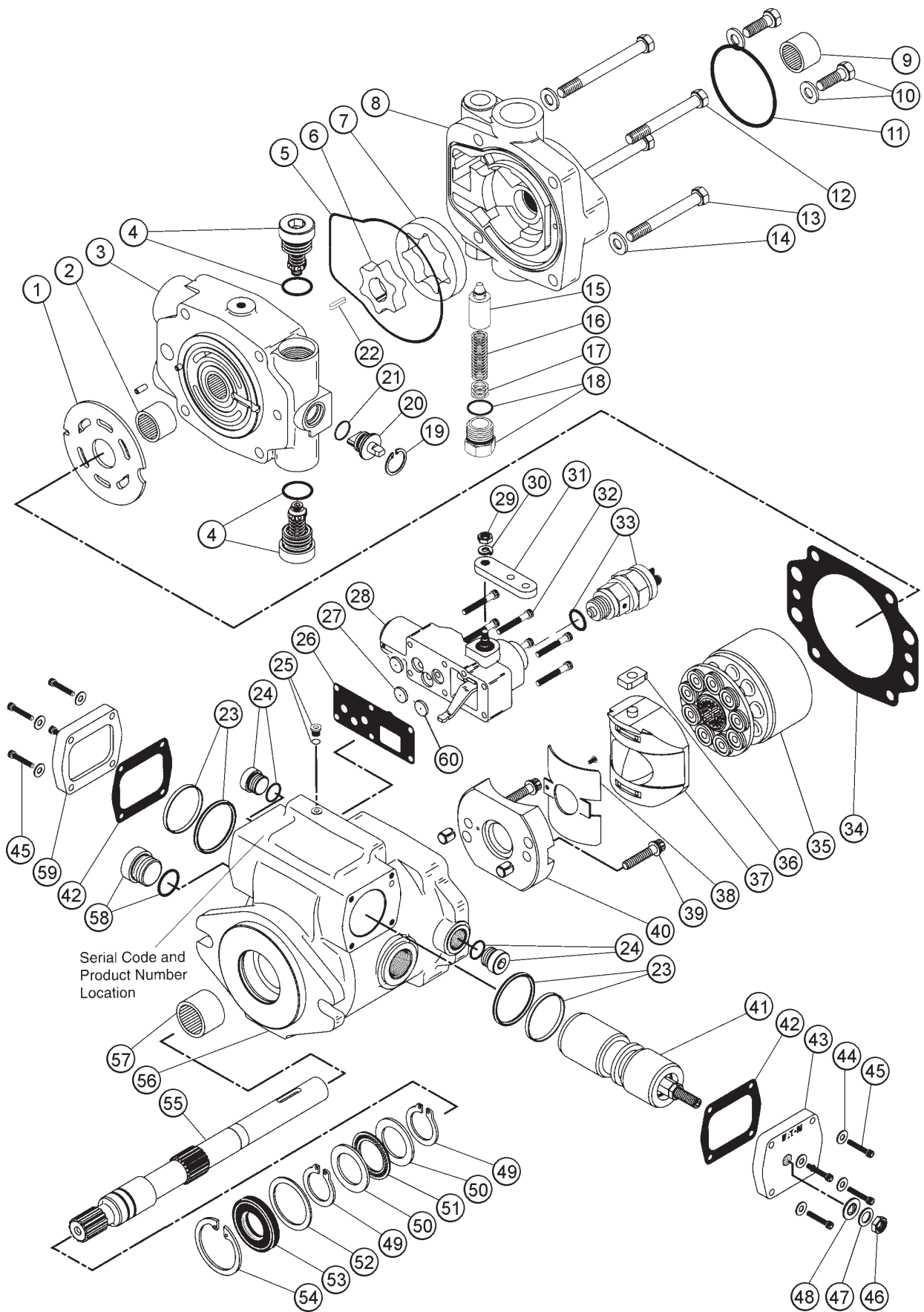

Serial Code and
Product Number
Location

PARTS

30-102 EATON PUMP PARTS LIST

REF#	PART#	DESCRIPTION	QUANTITY
1	33-058-16	Valve Plate (CW Rotation)	1
2	33-058-26	Bearing (Press Fit)	1
3	33-058-25	Back Plate Assembly	1
4	33-058-12	Relief Valve S/A	2
*		O-Ring	2
5*		Molded O-Ring	1
6	33-058-38	Inner Ring Gerotor	1
7	33-058-39	Outer Ring Gerotor	1
8	33-058-35	Charge Pump Adapter Assembly	1
9	33-058-46	Bearing (Press Fit)	1
10		Bolt and Washer	2
11*		O-Ring	1
12	33-058-14	Cap Screw $\frac{3}{8}$ - 16 x 4	2
13	33-058-13	Cap Screw $\frac{3}{8}$ - 16 x $3\frac{1}{2}$	2
14	33-058-44	Washer	4
15	33-058-50	Poppet	1
16	33-058-49	Spring	1
17	33-058-48	Shims	As Required
18	33-058-47	Plug	1
*		O-Ring	1
19*		Retaining Ring	1
20	33-058-41	Dump Valve Actuator	1
21*		Quad-Ring	1
22	33-058-34	Key	1
23*		Seal Sub-Assembly	2
24	33-058-32	Plug S/A	2
*		O-Ring	2
25	33-058-19	Plug Sub-Assembly	1
*		O-Ring	1
26*		Control Housing Gasket	1
27	33-058-40	Control Valve Orifice	1
28	33-058-37	Servo Control Assembly	1
29	33-058-29	Nut	1
30	33-058-30	Lockwasher	1
31	33-058-36	Control Arm	1
32	33-058-15	Cap Screw	6
33	33-058-45	Interlock Switch	1
34*		Housing Gasket	1
35	33-058-04	Rotating Kit Assembly	1
36	33-058-06	Servo Piston Follower	1
37	33-058-09	Cam Plate S/A	1
38	33-058-22	Bushing	1
39	33-058-24	Cap Screw	2
40	33-058-20	Cradle Sub-Assembly	1
41	33-058-05	Servo Piston Assembly	1
42*		Cover Plate Gasket	2
43	33-058-08	Cover Plate	1
44	33-058-43	Washer	8
*	33-058-01	Seal Repair Kit	

(Continued on next page)

30-102 EATON PUMP DRAWING

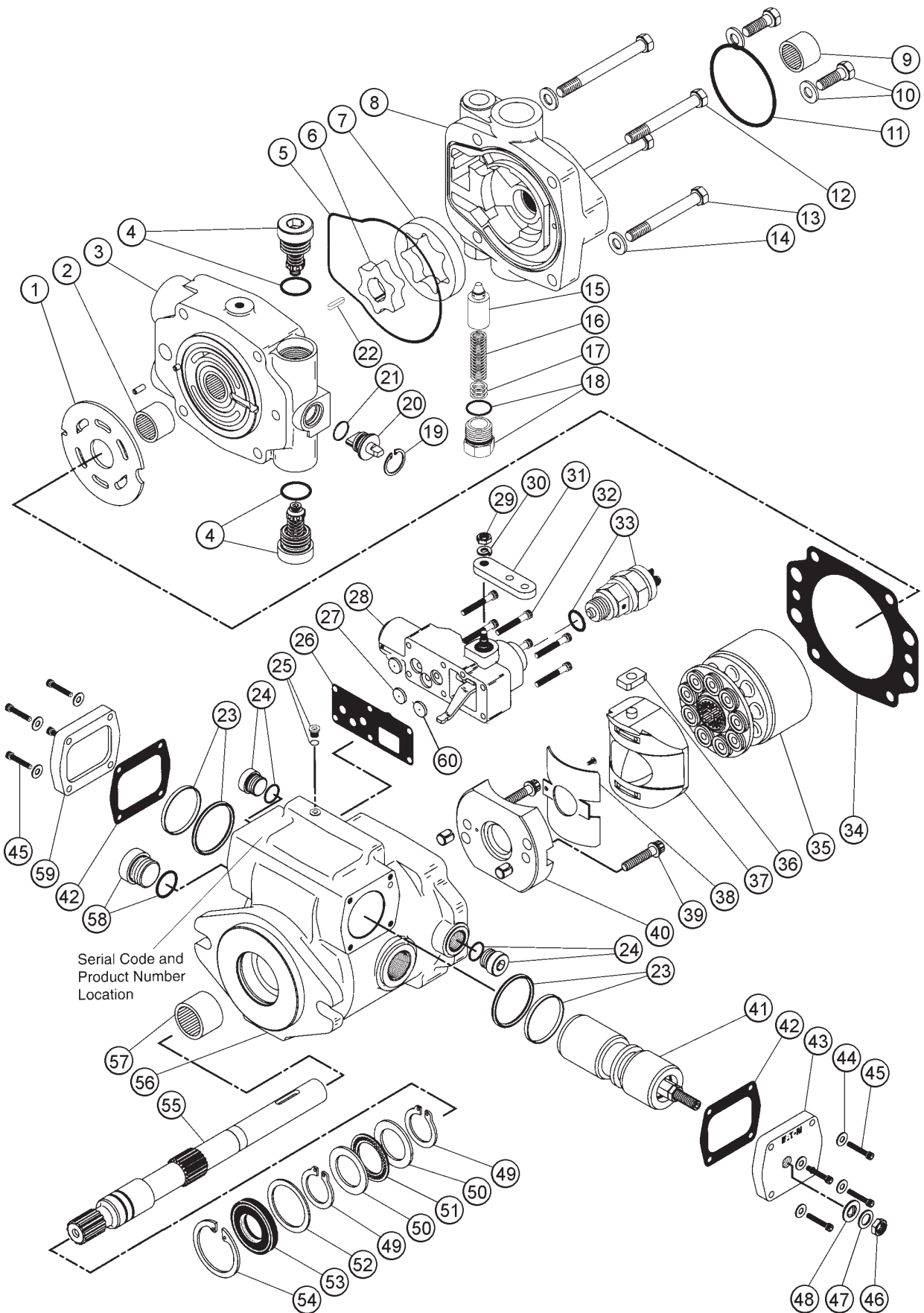

Serial Code and
Product Number
Location

PARTS

30-102 EATON PUMP PARTS LIST

REF#	PART#	DESCRIPTION	QUANTITY
45	33-058-03	Cap Screw #10 - 24 x 1	8
46	33-058-02	Jam Nut	1
47	33-058-42	Washer	1
48*		Seal Washer	1
49*		Retaining Ring	2
50	33-058-10	Thrust Race	2
51	33-058-11	Thrust Bearing	1
52	33-058-31	Washer	1
53*	33-058-52	Shaft Seal	1
54*		Retaining Ring	1
55	33-058-28	Drive Shaft	1
56	33-058-17	Housing Assembly	1
57	33-058-18	Bearing (Press Fit)	1
58	33-058-33	Plug S/A	1
*		O-Ring	1
59	33-058-07	Cover Plate	1
60	33-058-51	Control Valve Orifice	2
*	33-058-01	Seal Repair Kit	
NS	23-145	Oring (between gear pump and hydro pump)	1

30-101 EATON MOTOR DRAWING

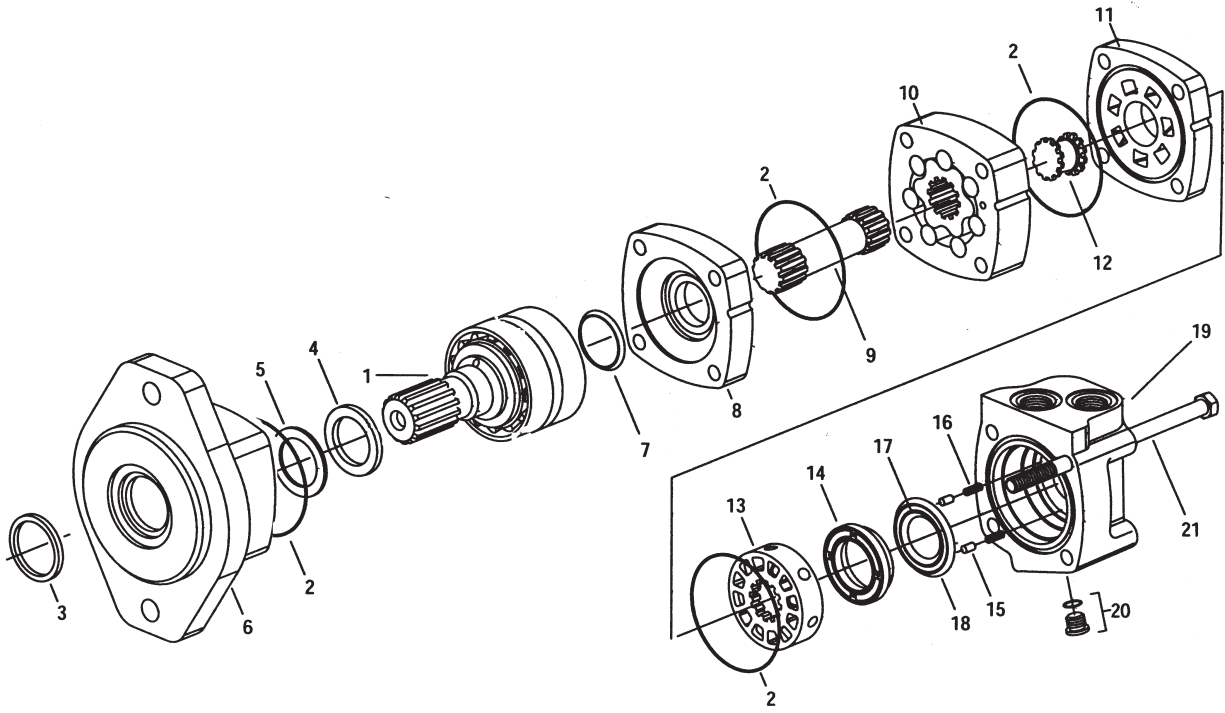

PARTS

30-101 EATON MOTOR PARTS LIST

REF#	PART#	DESCRIPTION	QUANTITY
1	30-101-01	Shaft and Bearing Kit (7/8 splined 13T)	1
2*		Seal	4
3*		Exclusion Seal	1
4*		Shaft Seal	1
5*		Back Up Ring	1
6	30-101-02	Bearing Housing	1
7*		Shaft Face Seal	1
8	30-101-03	Wear Plate	1
9	30-101-04	Main Drive	1
10	30-101-05	Geroler	1
11	30-101-06	Valve Plate	1
12	14-207	Valve Drive	1
13	14-208	Valve	1
14	30-101-07	Balance Ring	1
15	14-210	Balance Ring Pin	2
16	14-209	Compression Spring	2
17*		Inner Face Seal	1
18*		Outer Face Seal	1
19	30-101-08	Valve Housing	1
20	30-101-09	Plug Assembly	1
*		O-ring	1
21	30-101-10	Cap Screw	4
* 	30-101-11	Seal Kit	1 per

30-099 AUBURN® POWER WHEEL DRAWING

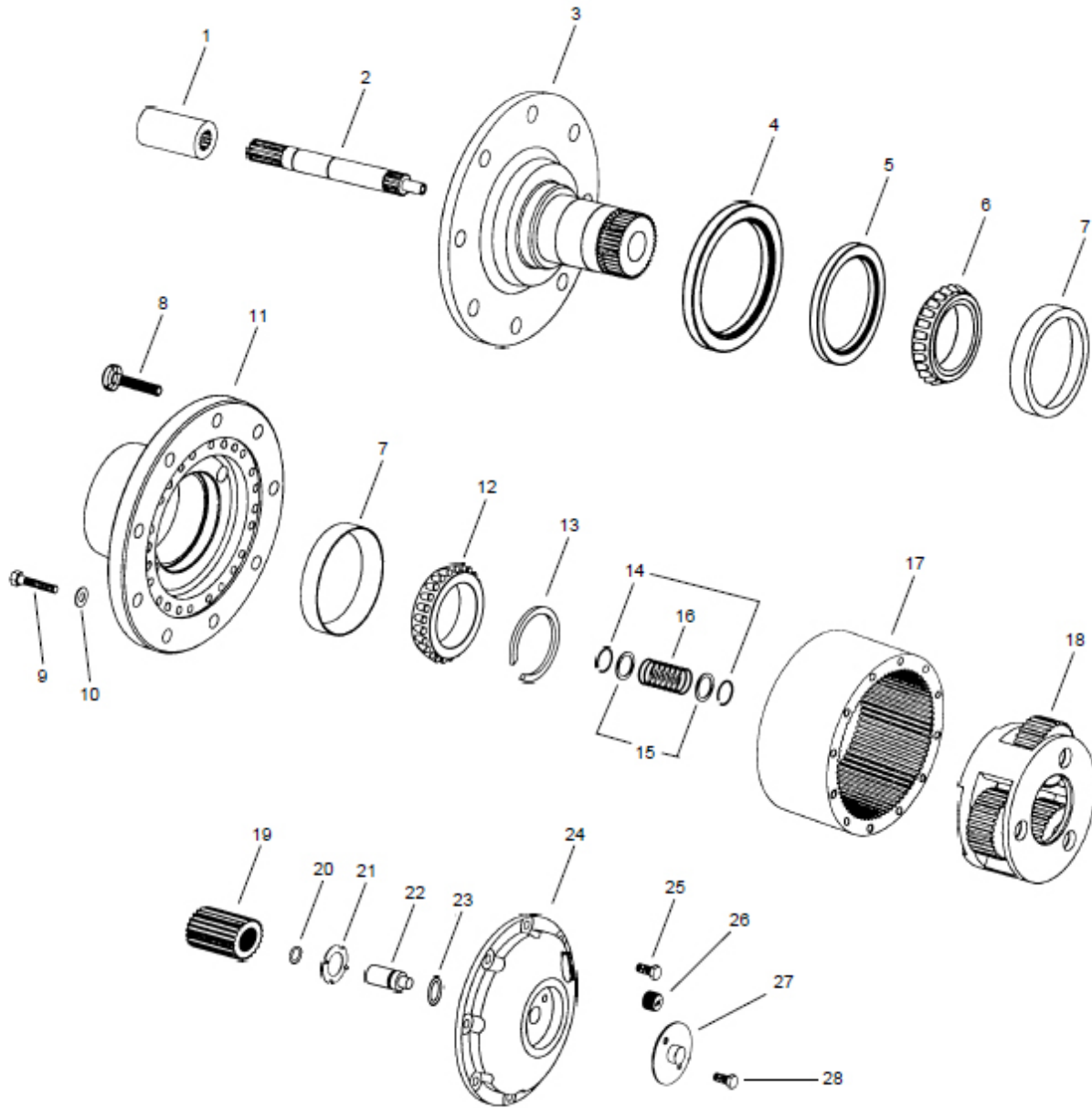

PARTS

30-099 AUBURN® POWER WHEEL PARTS LIST

REF#	PART#	DESCRIPTION	QUANTITY
1		Coupling	1
2		Input Shaft	1
3		Spindle	1
4†	30-099-02	Boot Seal	1
5*†	30-099-06	Oil Seal	1
6*		Bearing Cone	1
7*		Bearing Cup	2
8		Wheel Bolr	9
9		Hex Head Bolt (Grade 8)	6-12
10		Flat Washer	6-12
11		Hub	1
12*		Bearing Cone	1
13*†		Retaining Ring Kit	1
14	30-099-04	Retaining Ring	2
15		Washer	2
16	30-099-03	Disengage Spring	1
17		Ring Gear	1
18		Carrier Assembly	1
19		Sun Gear	1
20		Retaining Ring	1
21	30-099-07	Thrust Washer	1
22		Disengage Plunger	1
23*†		O-ring	1
24		Large Cover	1
25		Hex Head Bolt	8
26		Magnetic Plug	1
27		Disengage Cover	1
28		Hex Head Bolt	2
29		Quick Disconnect Gasket	1
30		Quick Disconnect Assembly	1
31		Hex Head Bolt	2
*	30-099-05	Bearing and Seal Kit	
†	30-099-01	Seal Kit	

3182 PLUMBING DRAWING (RAVEN 440)

15-818
15-817

#75 Fitting O-ring
#50 Fitting O-ring

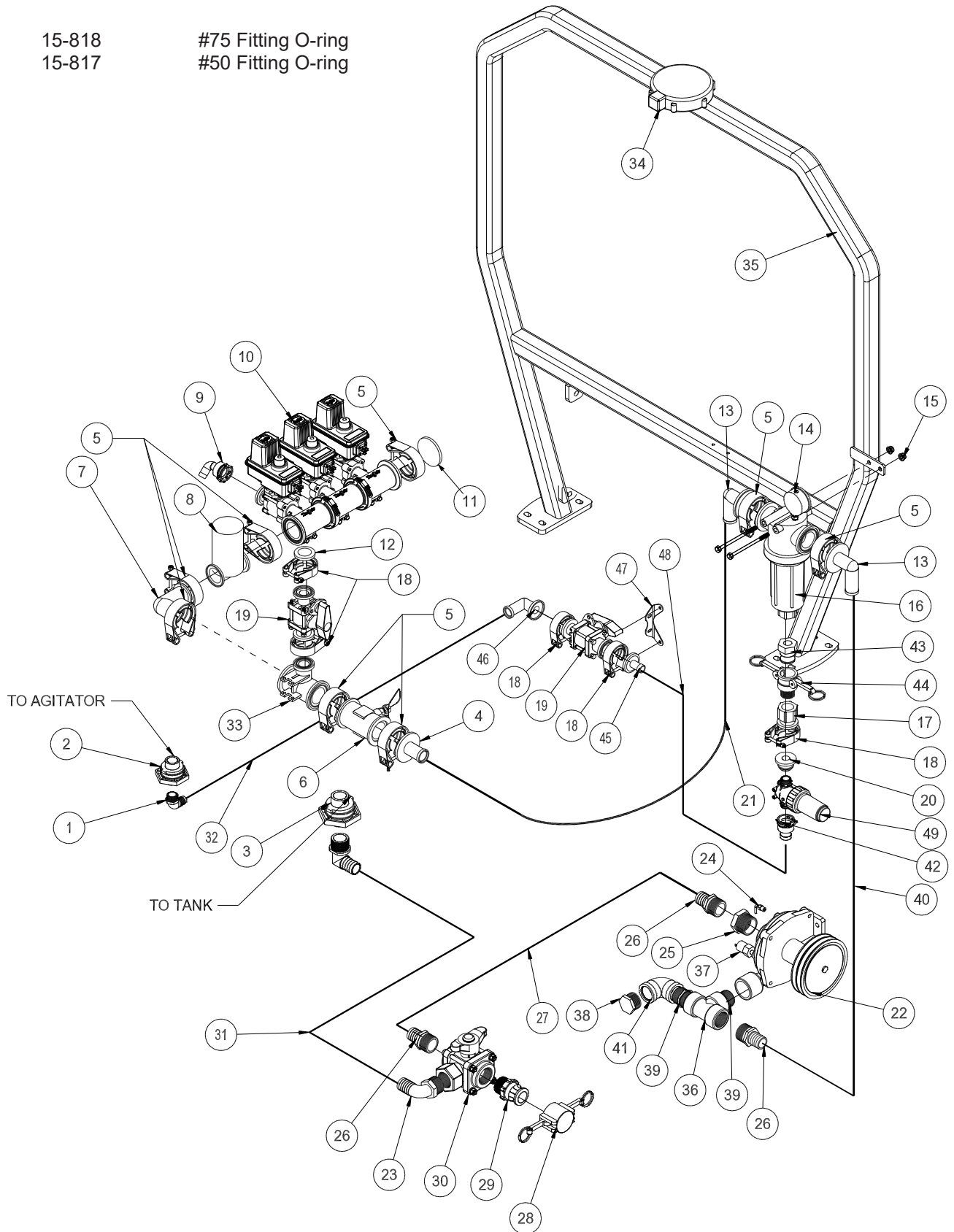

Accessories

3182 PLUMBING PARTS LIST (RAVEN 440)

REF#	PART#	DESCRIPTION	QUANTITY
1	16-155	Elbow	1
2	16-150	Double Threaded Fitting	1
3	16-194	Anti-Vortex Fitting	1
4	15-744	#75 1 ¹ / ₄ Hose Barb	1
5	15-741	#75 Series Clamp	8
6	18-373	Flow Meter	1
	18-373-01	Sensor	1
7	15-734	#75 Elbow Coupling	1
8	16-524	Motorized Control Valve	1
9	15-553	3 ³ / ₄ - 90° Hose Barb	3
	15-553-01	Clip	3
	15-553-02	O-ring	3
	8887-132	3 ³ / ₄ " Orange PVC Hose 132" (left boom)	1
	8887-90	3 ³ / ₄ " Orange PVC Hose 90" (center boom)	1
	8887-124	3 ³ / ₄ " Orange PVC Hose 124" (right boom)	1
	18-040	Hose Clamps	6
10	15-743	Manifold Valve	1
11	15-742	#75 Inlet Cover	1
12	15-778	Blank Gauge Port Flange	1
13	15-739	#75 x 90° x 1 ¹ / ₂ Hose Barb	2
14	16-281	Liquid Filled Gauge	1
15	HB-38-16-500	Bolt 3 ³ / ₈ - 16 x 5	2
	HNFL-38-16	Flange Lock Nut 3 ³ / ₈ - 16	2
16	15-737	Flanged Strainer	1
	16-968-03	Screen (50 mesh)	1
17	15-735	#50 x 1 Female Pipe thread Fitting	1
18	15-740	#50 Series Clamp	5
19	15-738	Flanged Ball Valve	2
20	15-825	#50 Male Quick Coupler	1
21	8897-60	1 ¹ / ₄ " Discharge Hose 60"	1
	18-116	Hose Clamp	2
22	16-998	Hypro Spray Pump	1
23	16-156	Elbow	2
24	33-494	Male Elbow	1
25	16-825	Hex Bushing	1
26	16-161	Fitting	3
27	8897-36	1 ¹ / ₄ " Discharge Hose 36"	1
	18-116	Hose Clamp	2
28	16-935	Quick Coupler Cap	1
29	16-180	Quick Coupler Male	1
30	18-372	3-Way Valve	1
	18-372-01	Handle	1
31	8897-23	1 ¹ / ₄ " Discharge Hose 23"	1
	18-116	Hose Clamp	2
32	8896-85	1" Discharge Hose 85"	1
	18-222	Hose Clamp	2
33	15-775	Reducer Tee	1
34	10-408-01	Phoenix 10 GPS	1
35	31-063	ROPs	1
36	18-390	Tee	1
37	33-480	Pressure Switch	1
38	10-389	Plug	1
39	16-880	Nipple	2
40	8897-64	1 ¹ / ₄ " Discharge Hose 48"	1
	18-116	Hose Clamp	2
41	16-182	90° Elbow	1
42	15-869	1" Hose Barb Outlet	1
	15-553-01	Clip	1
	15-553-02	O-ring	1
43	16-961	Adapter 1"	1
44	16-962	Coupler 1"	1
45	15-808	#50 Straight Hose Barb	1
46	15-746	#50 - 90° Hose Barb	1
47	20-689	Valve Bracket	1
48	8896-72	1" Discharge hose x 72"	1
	18-222	Hose Clamp	2
49	14-801	Agitator Line Strainer, 50 Mesh	1
	14-802	Replacement 50 Mesh Screen	

3184 PLUMBING DRAWING (RAVEN 203)

15-818
15-817

#75 Fitting O-ring
#50 Fitting O-ring

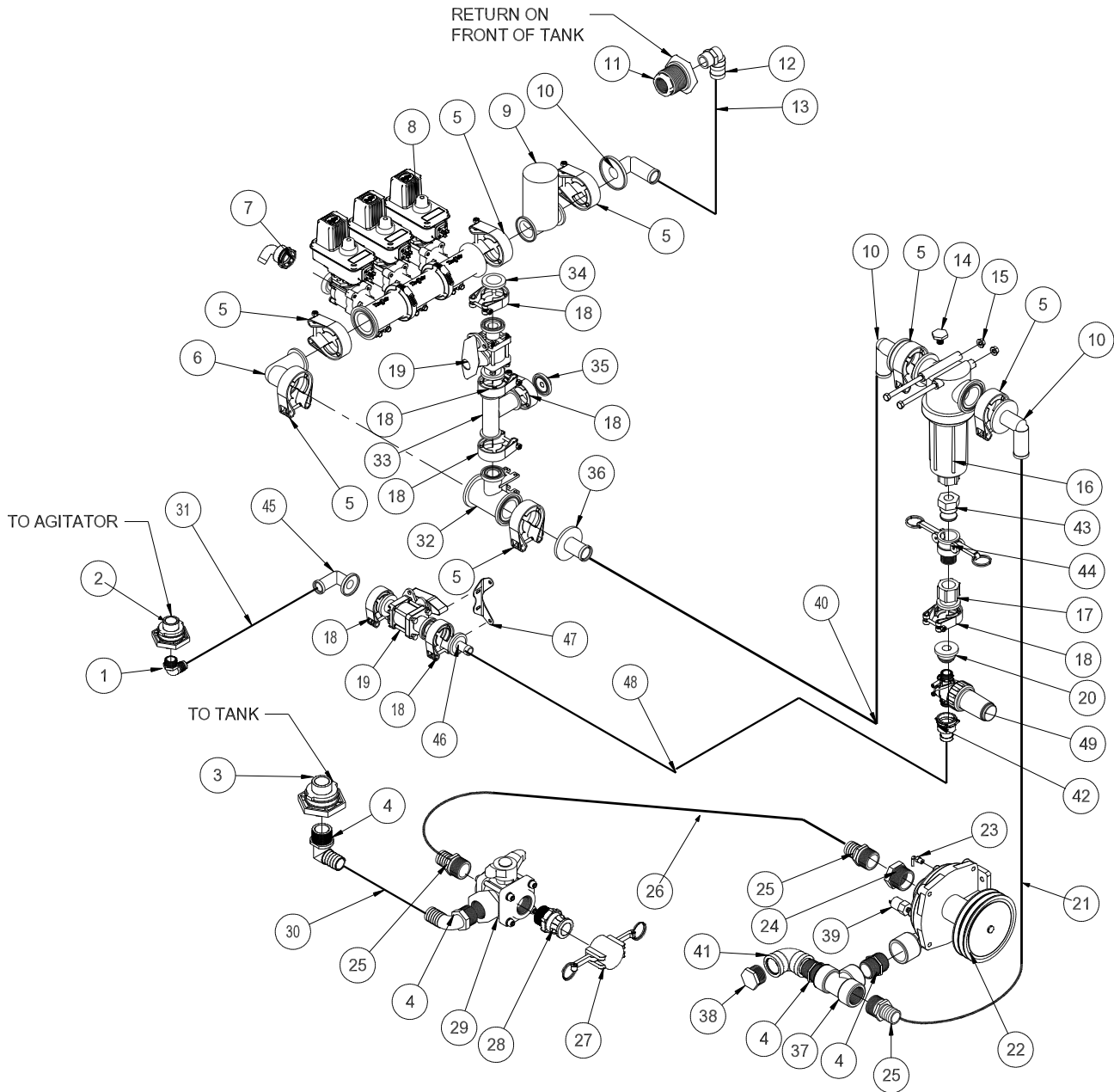

Accessories

3184 PLUMBING PARTS LIST (RAVEN 203)

REF#	PART#	DESCRIPTION	QUANTITY
1	16-155	Elbow	1
2	16-150	Double Threaded Fitting	1
3	16-194	Anti-Vortex Fitting	1
4	16-880	Nipple	3
5	15-741	#75 Series Clamp	7
6	15-734	#75 Elbow Coupling	1
7	15-553	3/4" - 90° Hose Barb	3
	15-553-01	Clip	3
	15-553-02	O-ring	3
	8887-120	3/4" Orange PVC Hose 120"	3
	18-040	Hose Clamps	6
8	15-743	Manifold Valve	1
9	16-524	Motorized Control Valve	1
10	15-739	#75 x 90° x 1 1/2" Hose Barb	3
11	16-945	Double Threaded Fitting	1
12	15-779	Hose Barb	1
13	8897-44	1 1/4" Discharge Hose 44"	1
	18-116	Hose Clamp	2
14	15-780	1/4" Poly Hex Plug	1
15	HB-38-16-500	Bolt 3/8" - 16 x 5	2
	HNFL-38-16	Flange Lock Nut 3/8" - 16	2
16	15-737	Flanged Strainer	1
	16-968-03	Screen (50 mesh)	1
17	15-735	#50 x 1 Female Pipe thread Fitting	1
18	15-740	#50 Series Clamp	5
19	15-738	Flanged Ball Valve	2
20	15-825	#50 Male Quick Coupler	1
21	8897-64	1 1/4" Discharge Hose 64"	1
	18-116	Hose Clamp	2
22	16-998	Hypro Spray Pump	1
23	33-494	Male Elbow	1
	8954-30	Clear Hose	1
24	16-825	Hex Bushing	1
25	16-161	Fitting	3
26	8897-24	1 1/4" Discharge Hose 24"	1
	18-116	Hose Clamp	2
27	16-935	Quick Coupler Cap	1
28	16-180	Quick Coupler Male	1
29	18-372	3-Way Valve	1
	18-372-01	Handle	1
30	8897-36	1 1/4" Discharge Hose 36"	1
	18-116	Hose Clamp	2
31	8896-85	1" Discharge Hose 85"	1
	18-222	Hose Clamp	2
32	15-775	Reducer Tee	1
33	15-776	#50 Series Tee	1
34	15-778	Blank Gauge Port Flange	1
35	15-777	Gauge Port Flange	1
36	15-744	#75 1 1/4" Hose Barb	1
37	18-390	Tee	1
38	10-389	Plug	1
39	33-480	Pressure Switch	1
40	8897-60	1 1/4" Discharge Hose 60"	1
	18-116	Hose Clamp	2
41	16-182	90° Elbow	1
42	15-869	1" Hose Barb Outlet	1
	15-553-01	Clip	1
	15-553-02	O-ring	1
43	16-961	Adapter 1"	1
44	16-962	Coupler 1"	1
45	15-746	#50 - 90° Hose Barb	1
46	15-808	#50 Straight Hose Barb	1
47	20-689	Valve Bracket	1
48	8896-72	1" Discharge Hose x 72"	1
	18-222	Hose Clamp	2
49	14-801	Agitator Line Strainer, 50 Mesh	1
	14-802	Replacement 50 Mesh Screen	

3185/3186 PLUMBING DRAWING (ENVIZIO PRO II + SHARP SHOOTER)

15-818
15-817

#75 Fitting O-ring
#50 Fitting O-ring

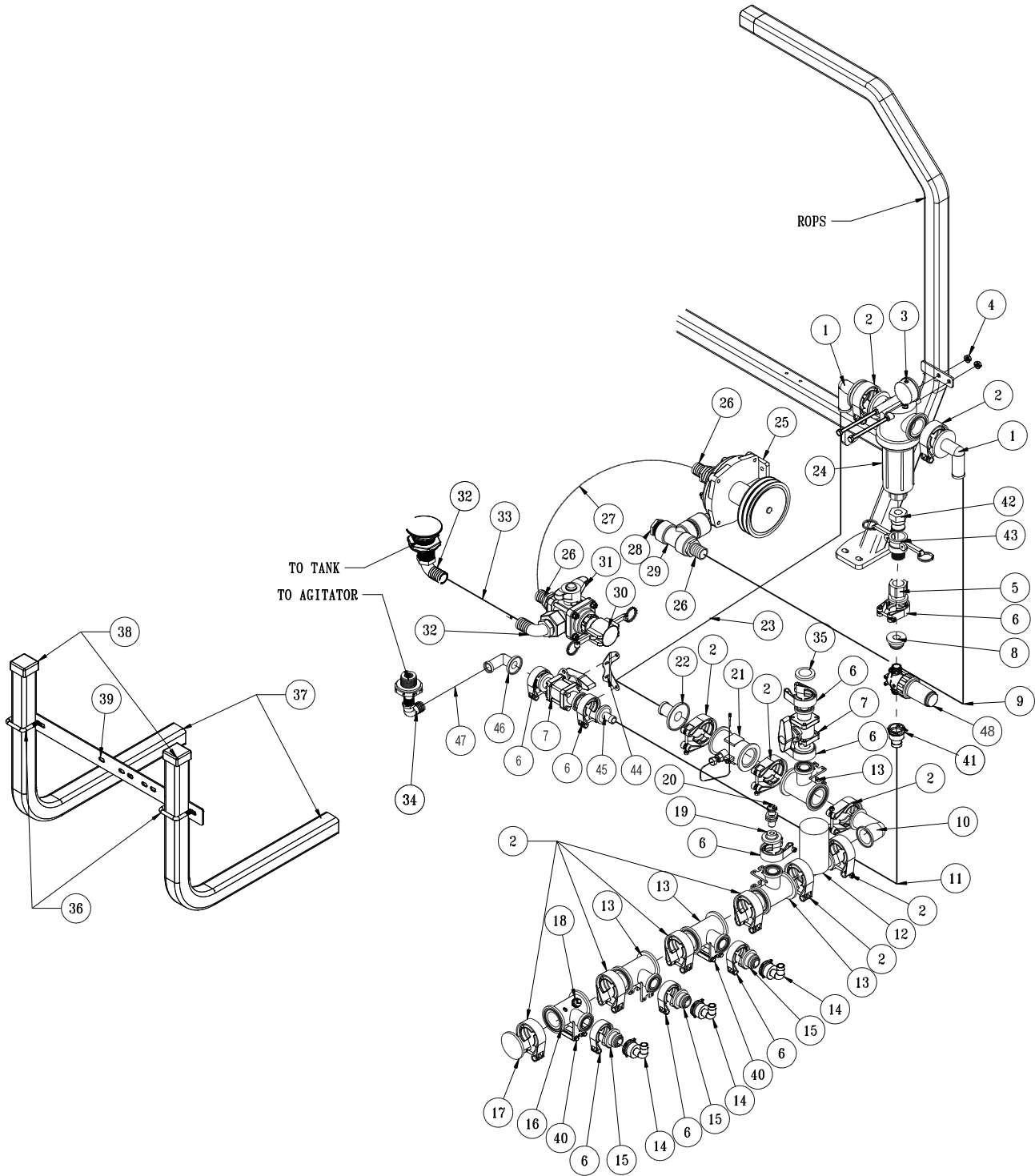

Accessories

3185/3186 PLUMBING PARTS LIST (ENVIZIO PRO II + SHARP SHOOTER)

REF#	PART#	DESCRIPTION	QUANTITY
1	15-739	#75 90° Hose Barb	2
2	15-741	#75 Series Clamp	11
3	16-281	Liquid Filled Gauge	1
4	HB-38-16-550	Bolt $\frac{3}{8}$ - 16 x $5\frac{1}{2}$	2
	HNFL-38-16	Flange Lock Nut $\frac{3}{8}$ - 16	2
5	15-735	#50 x 1 FTP Fitting	1
6	15-740	#50 Series Clamp	8
7	15-738	Flanged Ball Valve	2
8	15-825	#50 Male Quick Coupler	1
9	8897-64	1 $\frac{1}{4}$ " Discharge Hose x 64"	1
	18-116	Hose Clamp	2
10	15-734	#75 Elbow Coupling	1
11	8896-72	1" Discharge Hose x 72"	1
	18-222	Hose Clamp	2
12	16-524	Motorized Control Valve	1
13	15-775	Reducer Tee	4
14	15-553	$\frac{3}{4}$ - 90° Hose Barb	3
	8887-124	$\frac{3}{4}$ " Orange PVC Hose x 124" (Right Boom)	1
	8887-90	$\frac{3}{4}$ " Orange PVC Hose x 90" (Center Boom)	1
	8887-132	$\frac{3}{4}$ " Orange PVC Hose x 132" (Left Boom)	1
	18-040	Hose Clamp	6
15	15-825	QC Flange Adapter	3
16	30-164	Tapped Reducer Tee	1
17	15-742	#75 Inlet Cover	1
18	30-168-04	SharpShooter Presser Sensor Assembly	1
19	15-777	Gauge Port Flange	1
20	30-177	Envizio Pro II® Pressure Transducer	1
21	18-373	Flow Meter	1
	18-373-01	Sensor	1
22	15-744	#75 Hose Barb	1
23	8897-60	1 $\frac{1}{4}$ " Discharge Hose x 60"	1
	18-116	Hose Clamp	2
24	15-737	Flanged Strainer	1
	16-968-05	Screen (80 mesh)	1
25	16-998	Hypro® Pump	1
26	16-161	Fitting	3
27	8897-36	Discharge Hose	1
	18-116	Hose Clamp	2
28	10-389	Plug	1
29	18-390	Pipe Tee	1
30	16-935	Quick Coupler Cap	1
	16-180	Quick Coupler Male	1
31	18-372	3-Way Valve	1
32	16-156	Elbow	2
33	8897-24	1 $\frac{1}{4}$ " Discharge Hose x 24"	1
	18-116	Hose Clamp	2
34	16-155	Elbow	1
35	15-778	Blank Gauge Port Flange	1
36	17-537	Square U-bolt	2
37	17-615	Universal Boom Support	2
38	16-557	Square Cap	2
39	30-167	Mounting Strap	1
40	15-743-03	Mounting Rail	2
	15-743-06	SS Screw	8
41	15-869	1" Hose Barb Outlet	1
	15-553-01	Clip	1
	15-553-02	O-ring	1
42	16-961	Adapter1"	1
43	16-962	Coupler 1"	1
44	20-689	Valve Bracket	1
45	15-808	#50 Straight Hose Barb	1
46	15-746	#50 -90° Hose Barb	1
47	8896-85	1" Discharge Hose x 85"	1
	18-222	Hose Clamp	2
48	14-801	Agitator Line Strainer, 50 Mesh	1
	14-802	Replacement 50 Mesh Screen	

3187/3188 PLUMBING DRAWING (RAVEN 400 + SHARPSHOOTER)

15-818
15-817

#75 Fitting O-ring
#50 Fitting O-ring

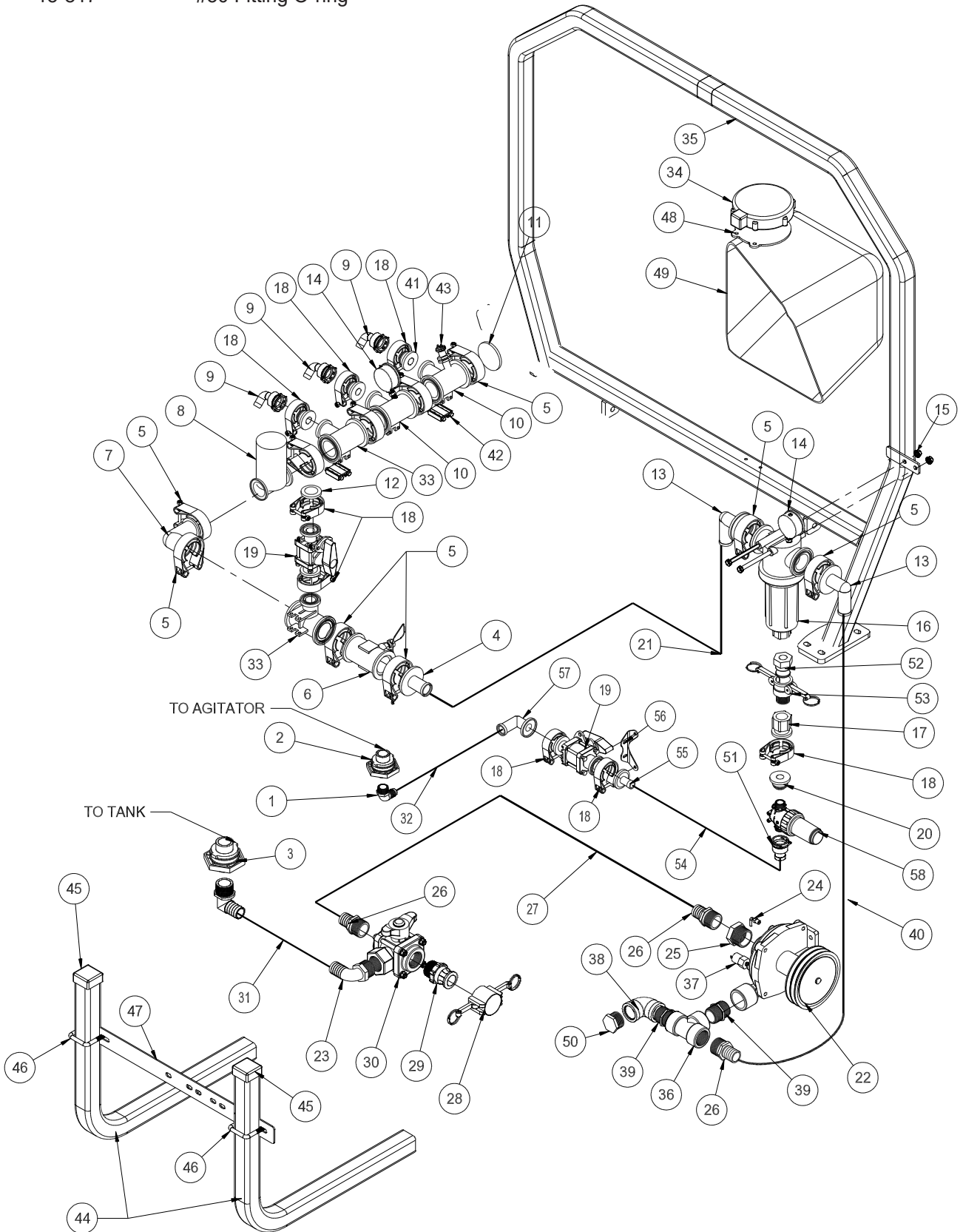

Accessories

3187/3188 PLUMBING PARTS LIST (RAVEN 440 + SHARPSHOOTER)

REF#	PART#	DESCRIPTION	QUANTITY
1	16-155	Elbow	1
2	16-150	Double Threaded Fitting	1
3	16-194	Anti-Vortex Fitting	1
4	15-744	#75 1 ¹ / ₄ Hose Barb	1
5	15-741	#75 Series Clamp	10
6	18-373	Flow Meter	1
	18-373-01	Sensor	1
7	15-734	#75 Elbow Coupling	1
8	16-524	Motorized Control Valve	1
9	15-553	³ / ₄ - 90° Hose Barb	3
	15-553-01	Clip	3
	15-553-02	O-ring	3
	8887-132	³ / ₄ " Orange PVC Hose 132" (left boom)	1
	8887-90	³ / ₄ " Orange PVC Hose 90" (center boom)	1
	8887-124	³ / ₄ " Orange PVC Hose 124" (right boom)	1
	18-040	Hose Clamps	6
10	30-164	Tapped Reducer Tee	2
11	15-742	#75 Inlet Cover	1
12	15-778	Blank Gauge Port Flange	1
13	15-739	#75 x 90° x 1 ¹ / ₂ Hose Barb	2
14	16-281	Liquid Filled Gauge	2
15	HB-38-16-550	Bolt ³ / ₈ - 16 x 5 ¹ / ₂	2
	HNFL-38-16	Flange Lock Nut ³ / ₈ - 16	2
16	15-737	Flanged Strainer	1
	16-968-05	Screen (80 mesh)	1
17	15-735	#50 x 1 Female Pipe thread Fitting	1
18	15-740	#50 Series Clamp	7
19	15-738	Flanged Ball Valve	2
20	15-825	#50 Male Quick Coupler	1
21	8897-60	1 ¹ / ₄ " Discharge Hose 60"	1
	18-116	Hose Clamp	2
22	16-998	Hypro Spray Pump	1
23	16-156	Elbow	2
24	33-494	Male Elbow	1
25	16-825	Hex Bushing	1
26	16-161	Fitting	3
27	8897-36	1 ¹ / ₄ " Discharge Hose 36"	1
	18-116	Hose Clamp	2
28	16-935	Quick Coupler Cap	1
29	16-180	Quick Coupler Male	1
30	18-372	3-Way Valve	1
	18-372-01	Handle	1
31	8897-24	1 ¹ / ₄ " Discharge Hose 24"	1
	18-116	Hose Clamp	2
32	8896-85	1" Discharge Hose 85"	1
	18-222	Hose Clamp	2
33	15-775	Reducer Tee	2
34	10-408-01	Phoenix 10 GPS	1
35	31-063	ROPs	1
36	18-390	Tee	1
37	33-480	Pressure Switch	1

(continued on next page)

3187/3188 PLUMBING DRAWING (RAVEN 400 + SHARPSHOOTER)

15-818
15-817

#75 Fitting O-ring
#50 Fitting O-ring

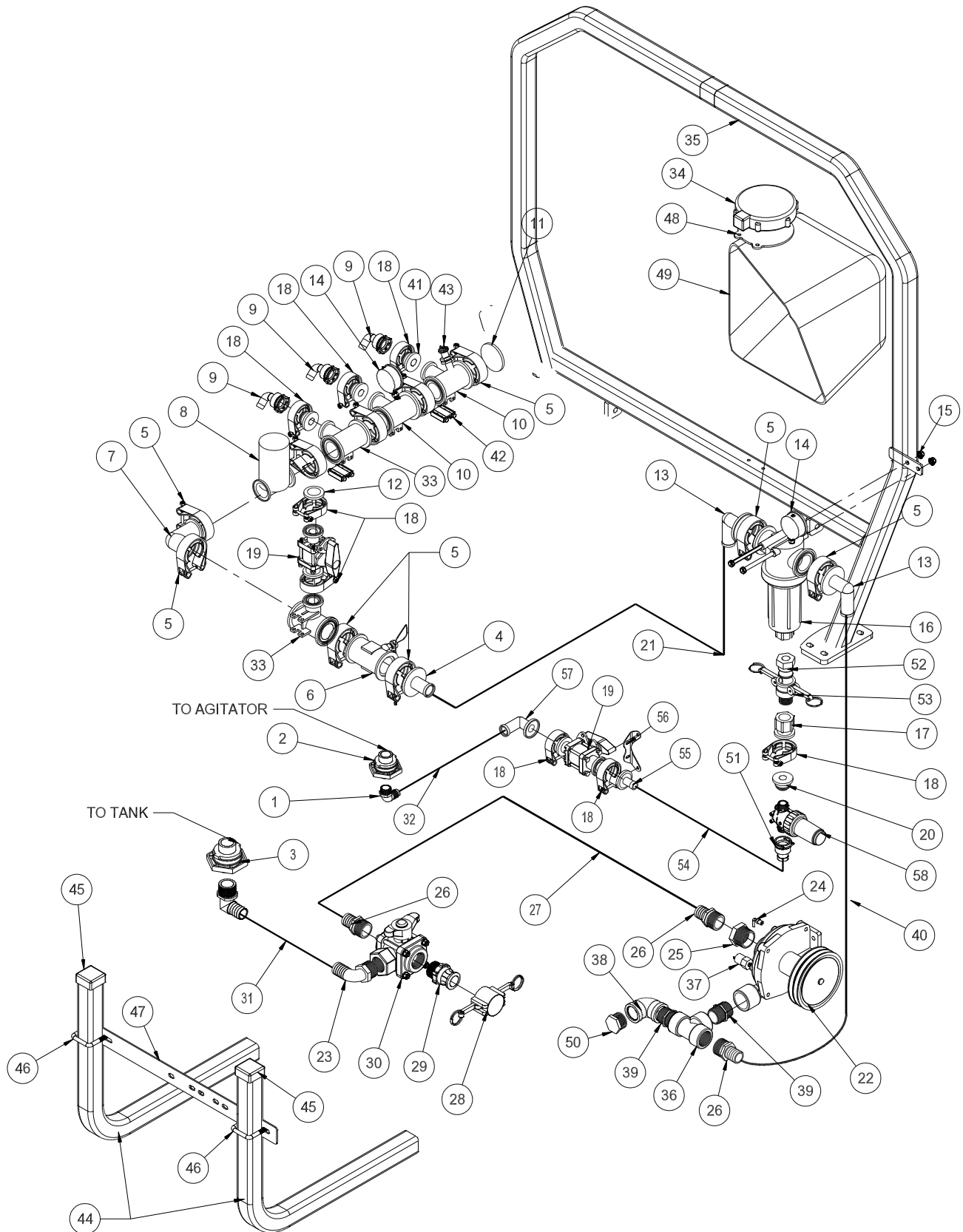

Accessories

3187/3188 PLUMBING PARTS LIST (RAVEN 440 + SHARPSHOOTER)

REF#	PART#	DESCRIPTION	QUANTITY
38	16-182	90° Elbow	1
39	16-880	Nipple	2
40	8897-64	1 1/4" Discharge Hose 64"	1
	18-116	Hose Clamp	2
41	15-825	QC Flange Adapter	3
42	15-743-03	Mounting Rail	2
	15-743-06	SS Screws	8
43	30-168-04	SharpShooter Pressure Sensor	1
44	17-615	Universal Boom Support	2
45	16-557	Square Cap	2
46	17-537	Square U-bolt	2
47	30-167	Mounting Strap	1
48	30-173	GPS Plate	1
49	30-172	Fiberglass Cover	1
50	10-389	Plug	1
51	15-869	1" Hose Barb Outlet	1
	15-553-01	Clip	1
	15-553-02	O-ring	1
52	16-961	Adapter1"	1
53	16-962	Coupler 1"	1
54	8896-72	1" Discharge Hose x 72"	1
	18-222	Hose Clamp	2
55	15-808	#50 Striaight Hose Barb	1
56	20-689	Valve Mount	1
57	15-746	#50 - 90° Hose Barb	1
58	14-801	Agitator Line Strainer, 50 Mesh	1
	14-802	Replacement 50 Mesh Screen	

CONTROLS 3182 SYSTEM DRAWING (RAVEN 440)

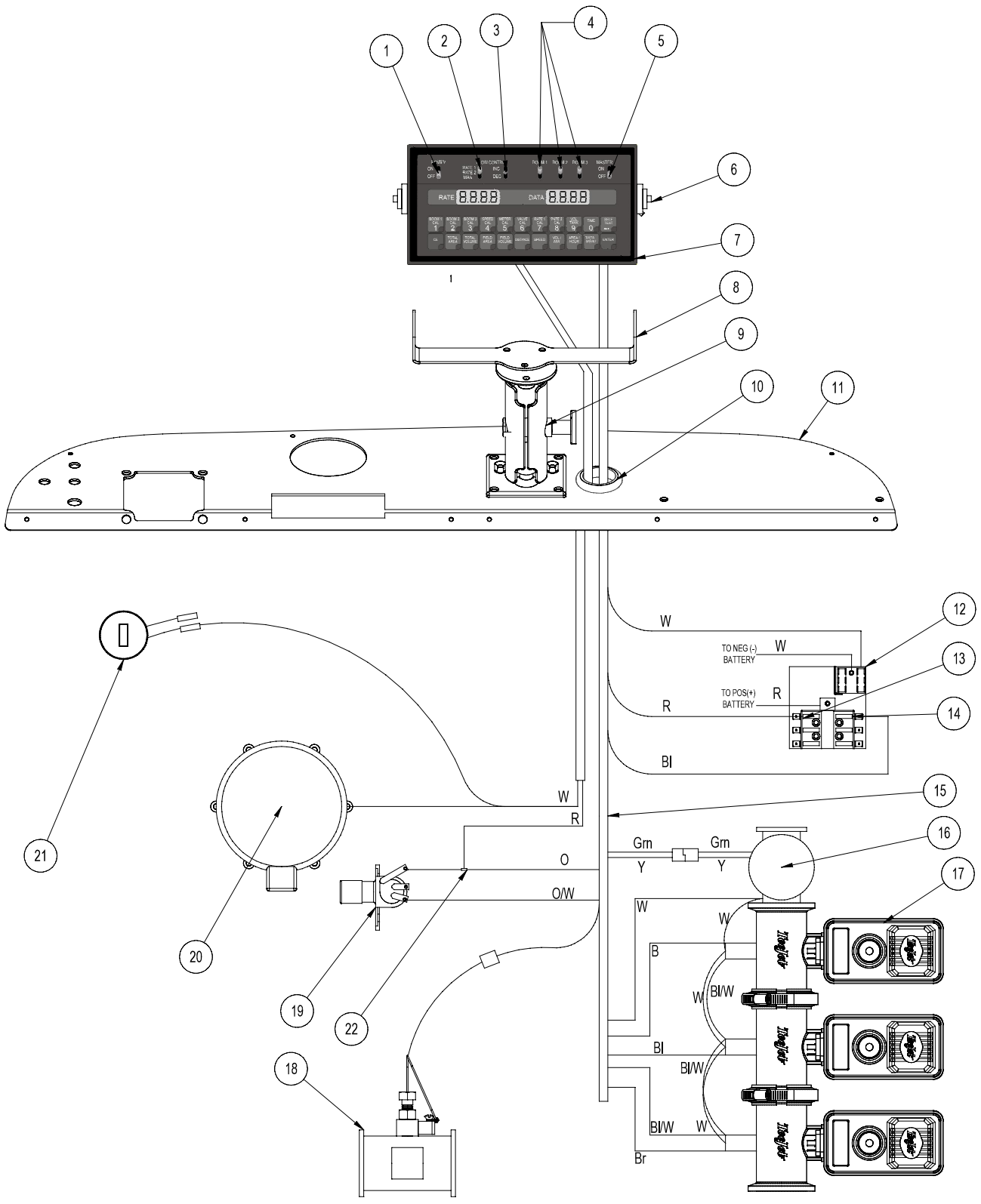

Accessories

CONTROLS 3182 SYSTEM PARTS LIST

REF#	PART#	DESCRIPTION	QUANTITY
1	16-140	Power Switch	1
2	16-525-01	Rate1/Rate2 Manual Switch	1
3	16-873	Adjustment Switch	1
4	16-141	Boom Switch	3
5	16-697	Master Switch	1
6	16-558	Mounting Knob	2
7	16-525	Console (only)	1
	16-234	Console Cover	1
8	20-557	440 Console Mount	1
9	20-540	Ram Mount	1
10	50-400	Grommet	1
11	20-596	Dash Board	1
12	33-271	Fuse Block	1
13	33-508	Auto Blade Type Fuse 15 amp	1
14	33-562	Auto Blade Type Fuse 40 amp	1
15	15-369	Console Control Cable	1
16	16-524	Motorized Control Valve	1
17	15-743	Manifold Valve	1
18	18-373	Flow Meter	1
19	33-509	Master Boom Floor Switch	1
20	10-408-01	Phoenix 10 GPS	1
	10-408-02	Cable	1
21	12-017	Hour Meter	1
22	9027	Terminal T-tap	1
	8958	Male Slide on Connector	1

Use Dielectric Grease On All Electrical Connections

CONTROLS 3184 SYSTEM DRAWING (RAVEN 203)

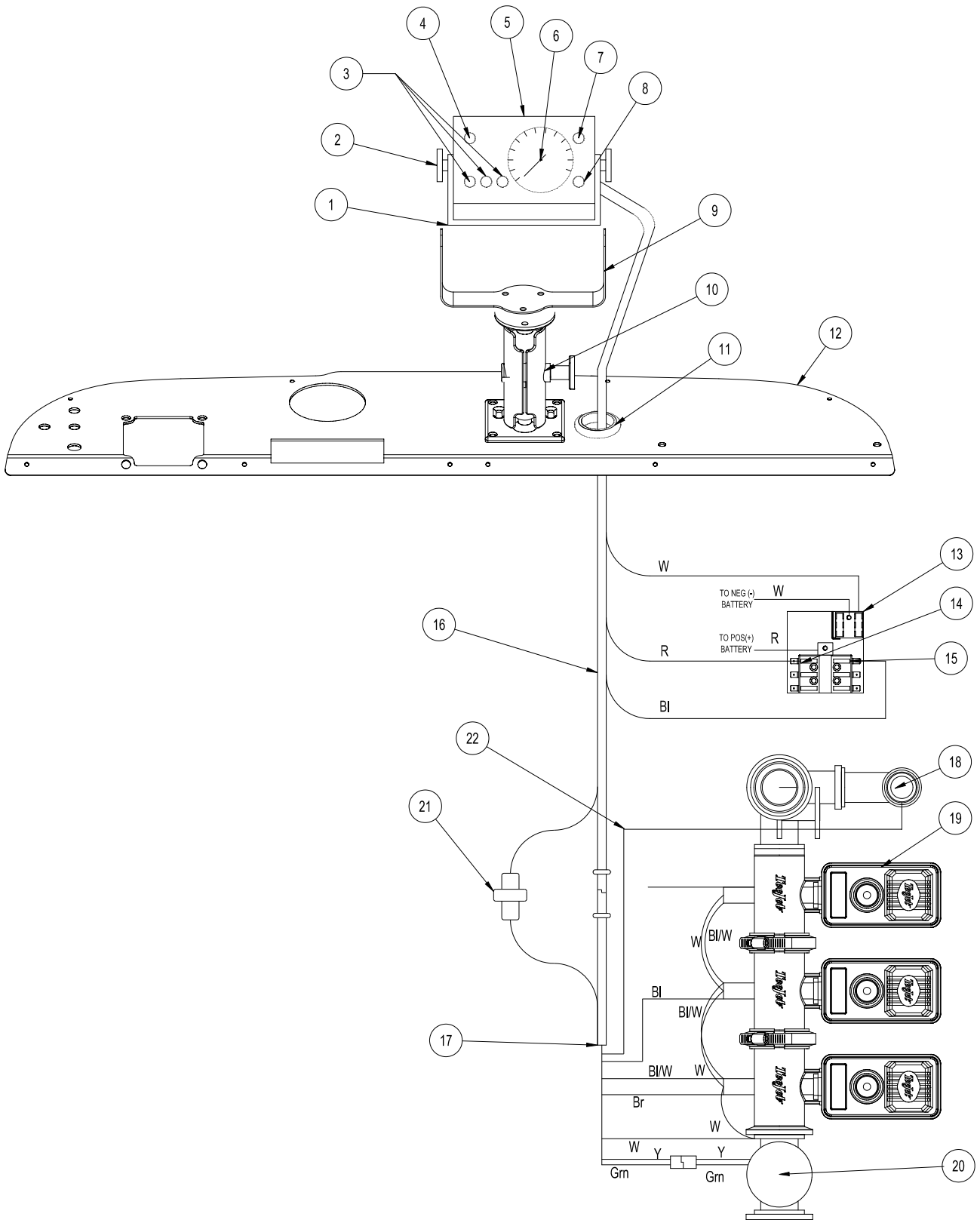

Accessories

CONTROLS 3184 SYSTEM PARTS LIST (RAVEN 203)

REF#	PART#	DESCRIPTION	QUANTITY
1	16-958-01	Mounting Bracket	1
3	16-898	Boom Switch	3
2	16-900	Mounting Knob	2
4	16-899	Master Switch	1
5	18-418	Console with Liquid Filled Pressure Gauge	1
6	33-090-02	Liquid Filled Pressure Gauge	1
	33-090-04	Pressure Gauge Tube Fitting	1
7	16-958-02	Fuse Holder	1
	16-525-03	Fuse 15 AMP	1
8	16-895	Pressure Switch	1
9	20-546	Console Mount	1
10	20-540	Ram Mount	1
11	50-400	Grommet	1
12	20-596	Dash Board	1
13	33-271	Fuse Block	1
14	33-508	Auto Blade Type Fuse 15 amp	1
15	33-562	Auto Blade Type Fuse 40 Amp	1
16	16-958-04	Cable Assembly 8ft Enclosure Hook-Up	1
17	16-902	Cable Assembly 72" Solenoid Hook-Up	1
18	15-776	Tee	1
19	15-743	Manifold Valve	1
20	16-524	Motorized Control Valve	1
21	16-958-05	Union Fitting	1
22	9038	1/4" Tubing	by the foot
23	10-225	Wire Harness (fuse block to electric valve)	1

Use Dielectric Grease On All Electrical Connections

WIRING 3185/3186 SYSTEM (ENVIZIO PRO II + SHARP SHOOTER W/ RATE-SYNC)

REF#	PART#	DESCRIPTION	QUANTITY
1	33-271	Fuse Block	1
	33-508	Auto Blade Type Fuse 15Amp	2
	33-273	Auto Blade Type Fuse 30Amp	1
	9035	Blade Fuse 1AMP	1
2	16-524	Motorized Control Valve	1
3	30-178	6' Cable for Transducer	1
4	30-177	Pressure Transducer	1
5	15-775	Tee	1
6	18-373	Flow Meter	1
7		See Valve Nozzle Drawing	
8	30-174	12' Product Cable	1
9	30-164	Tapped Reducer Tee	1
10	30-168-04	SharpShooter Pressure Sensor	1
11	30-176	3' Console Cable	1
12	30-264	SharpShooter with Rate Sync	1
	30-264-01	Display	1
13	30-173	GPS Plate	1
14	30-220	SwitchPro Kit	1
15	30-172	Fiberglass Cover	1
	8803-48	Trim 48"	1
	18-134	Grommet	1
16*	30-218-02	GPS Antenna	1
17*	30-218-03	GPS Cable	1
18*	30-218-01	Envizio Pro II Console	1
19	30-219	Combo Cable	1
20	30-270	DB9 Cable	1
*	30-218	Epro II with WAAS (includes * items)	
	30-228	GLONAS Unlock Code	

Use Dielectric Grease On All Electrical Connections

WIRING 3187/3188 SYSTEM (RAVEN 440 + SHARP SHOOTER)

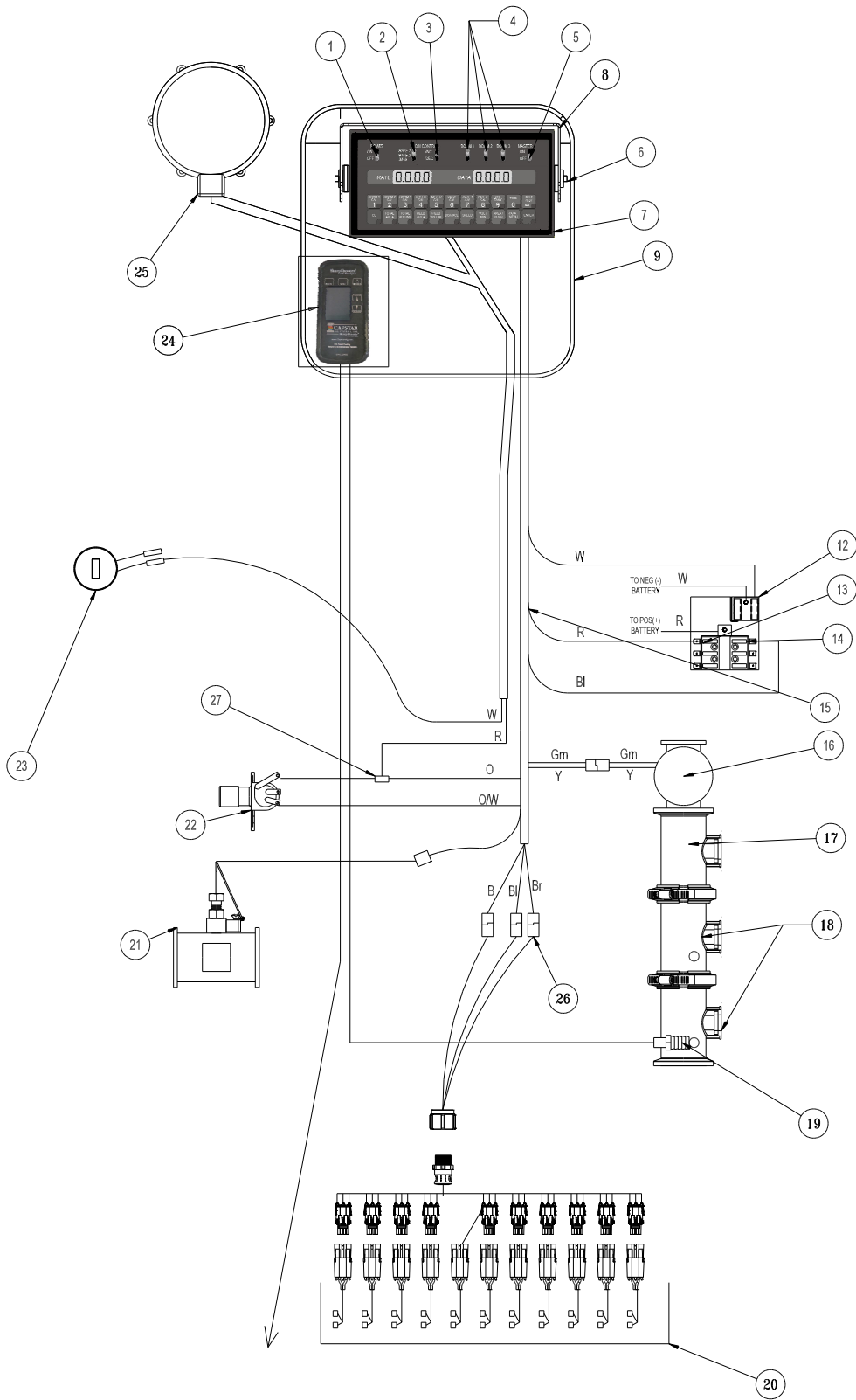

Accessories

WIRING 3187/3188 SYSTEM (RAVEN 440 + SHARP SHOOTER)

REF#	PART#	DESCRIPTION	QUANTITY
1	16-140	Power Switch	1
2	16-525-01	Rate1/Rate2 Manual Switch	1
3	16-873	Adjustment Switch	1
4	16-141	Boom Switch	3
5	16-697	Master Switch	1
6	16-558	Mounting Knob	2
7	16-525	Console (only)	1
8	20-601	440 Console Mount	1
9	30-172	Fiberglass Cover	1
	8803-48	Trim-48"	1
	18-134	Grommet ⁵ / ₈	1
10	50-400	Grommet	1
11	20-596	Dash Board	1
12	33-271	Fuse Block	1
	9035	Blade Fuse 1amp	1
13	33-508	Auto Blade Type Fuse 15 amp	2
14	33-273	Auto Blade Type Fuse 30 amp	1
15	15-369	Console Control Cable	1
16	16-524	Motorized Control Valve	1
17	15-775	Reducer Tee	1
18	30-164	Tapped Reducer	2
19	30-168-04	SharpShooter Pressure Sensor	1
20		See Valve Nozzle Drawing	
21	18-373	Flow Meter	1
22	33-509	Master Boom Floor Switch	1
23	12-017	Hour Meter	1
24	30-264	SharpShooter with Rate Sync	1
	30-264-01	Display	1
25	10-408-01	Phoenix 10 GPS	1
	10-408-02	Cable	1
	30-173	GPS Mount Plate	1
26	30-179	440 Harness Extension	1
27	9027	Terminal T-tap	1
	8958	Male Slide on Connector	1

Use Dielectric Grease On All Electrical Connections

16-524 MOTORIZED CONTROL VALVE DRAWING

WHEN SERVICING VALVE:

Replace valve body with ISO-Body Kit if valve has been leaking internally.

Replace motor assembly if the motor will not run.

Before reassembling valve, remove the coupler shaft from the valve body. Apply Loctite to coupler shaft and woodruff key. Place the coupler shaft (Ref 5) and the woodruff key (Ref 4) onto the motor shaft. Plug motor into the valve connector coming from Sprayer Control Console. Check that the motor rotates in both directions. Motor must stop when coupler shaft CAM releases printed circuit board button.

When reassembling valve, grease both sealing surfaces of coupler shaft. Insert coupler shaft into Iso-flange and be sure seal properly seats on shaft. Install motor on valve body and apply silicon sealant to mounting holes. Reassemble remaining items as shown in parts diagram.

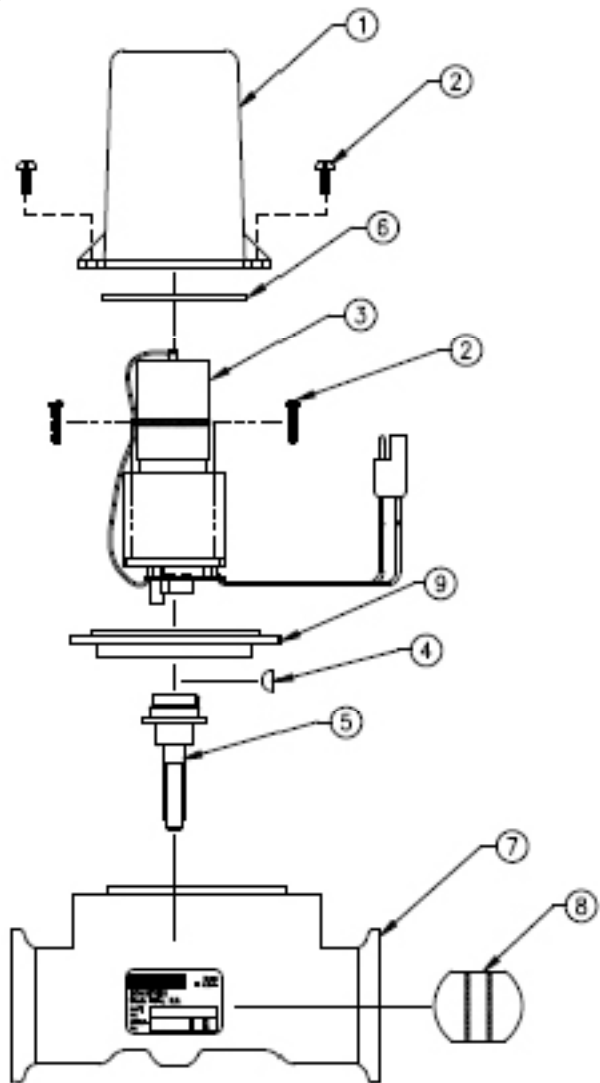

REF#	PART#	DESCRIPTION	QUANTITY
1	16-870	Valve Cover	1
2*	16-524-01	#6 Self Tapping Screw $\frac{3}{4}$ " Long	6
3	16-875	Motor Assembly	1
4*	16-957	Woodruff Key	1
5*	16-524-02	Coupler Shaft	1
6*	16-897	Seal Tetraseal	1
7*	16-524-06	Valve Body Assembly 1"	1
8*	16-956	Butterfly	1
9*	16-524-04	Isolation Flange Assembly	1
*	16-524-05	1" Valve ISO-Body Kit	

15-737 STRAINER

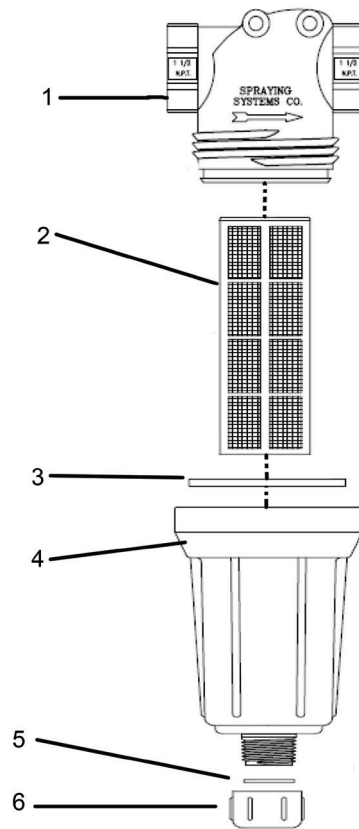

REF#	PART#	DESCRIPTION	QUANTITY
1	15-737-01	Strainer Head 75 Series	1
2	16-968-03	50 Mesh Strainer	1
	16-968-05	80 Mesh Strainer	1
3	14-521-02	EPDM Gasket	1
4	14-521-03	Bowl 1" NPT	1
5	14-521-04	EPDM Rubber gasket	1
6	14-521-05	Cap	1

15-743 MANIFOLD VALVE DRAWING

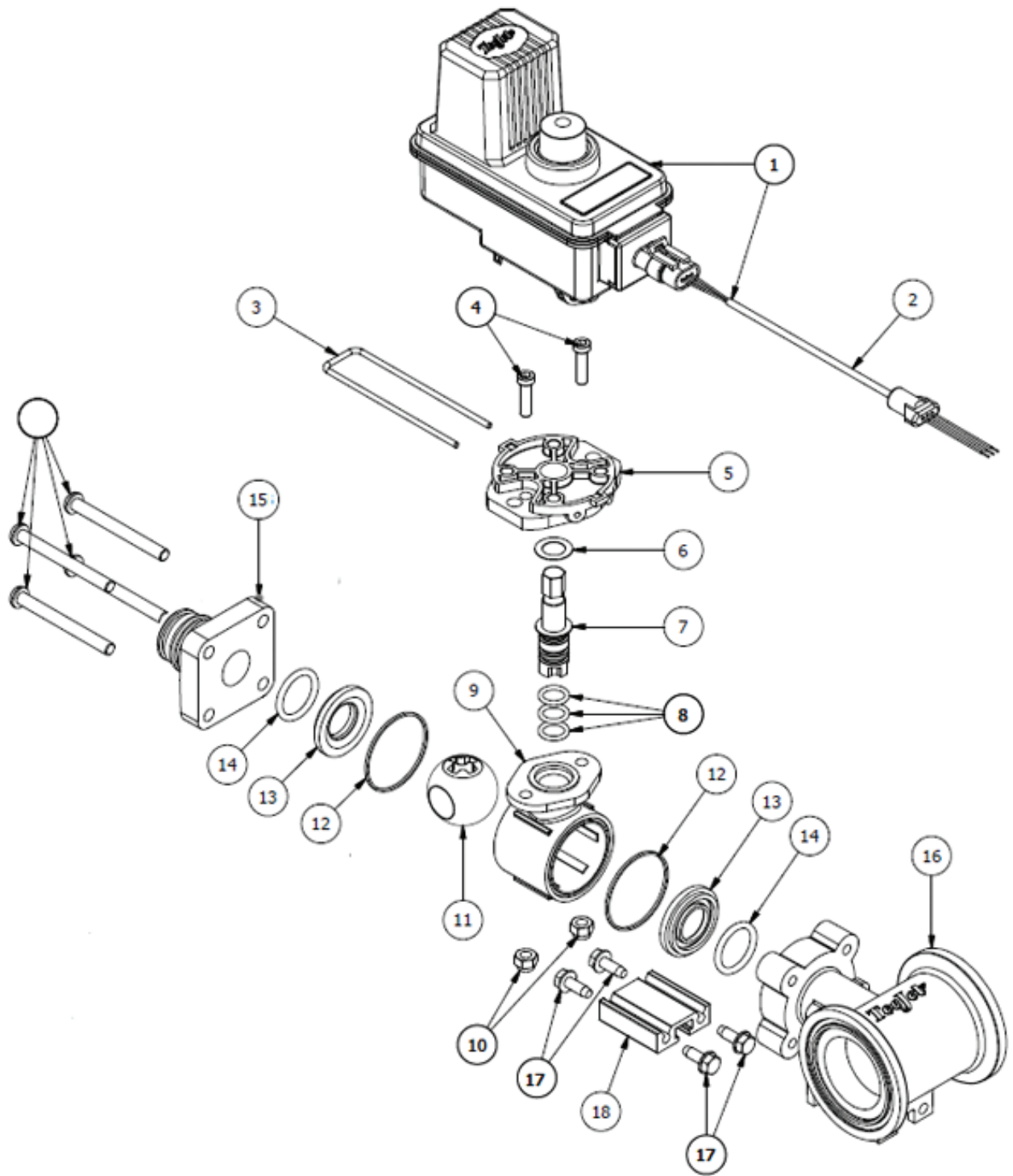

Accessories

15-743 MANIFOLD VALVE PARTS LIST

REF#	PART#	DESCRIPTION	QUANTITY
1	15-552-23	Motor	
2	15-878	Metri-Pack Cable (comes with motor)	1
3	15-552-24	Retaining Clip	1
4	15-552-25	Socket Head Cap Screw, Stainless Steel	2
5	15-552-26	Motor Adapter, Polypropylene	1
6*	15-517-11	Thrust Washer, Teflon	1
7	15-552-27	Stem, Stainless Steel	1
8*	15-552-05	O-ring, Viton	3
9	15-517-16	Body, Nylon	1
10		Lock Nut, Stainless Steel	2
11	15-743-04	Ball, Polypropylene	1
12*	15-552-13	Gasket, Viton	2
13*	15-517-19	Seal, Teflon	2
14*	15-517-20	O-ring, Viton	2
15	15-743-01	End Cap	1
16	15-743-02	#75 Tee Body	1
17	15-743-06	Screw, SS	4
18	15-743-03	Mounting Rail Aluminum	1
*	15-552-10	Spare Parts Kit (includes all * items)	
	15-743-05	Single Valve (shown)	

17-580 20' HEAVY BOOM

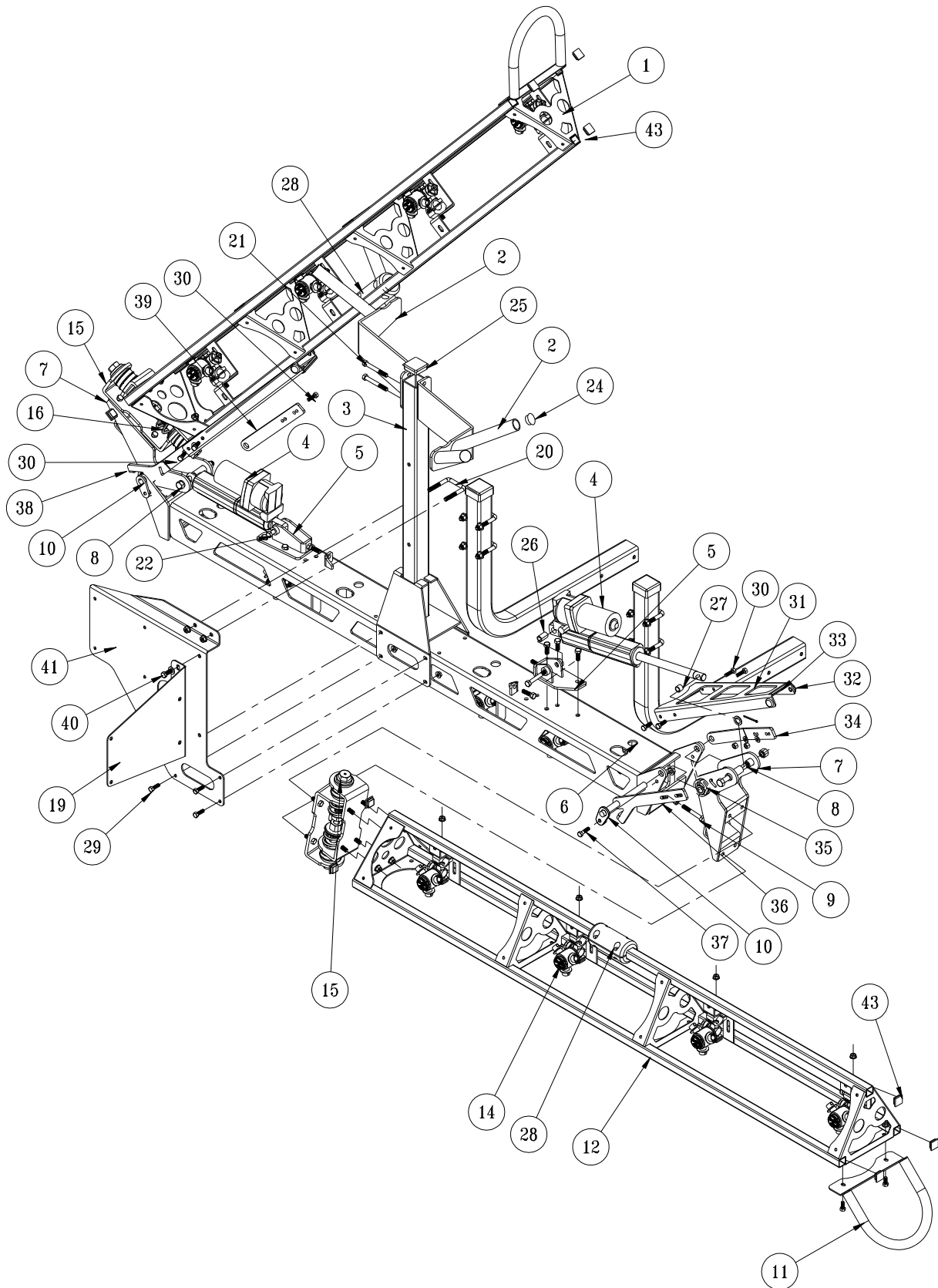

Accessories

17-580 20' HEAVY BOOM

REF#	PART#	DESCRIPTION	QUANTITY
1	17-531	Left Boom Arm	1
2	17-631	V-Boom Nest	2
3	17-578	Boom Nest Post	1
4	30-214	10" Electric Hydraulic Actuator	2
5	30-184	Actuator Mount	2
	HN-38-16	Nut, $\frac{3}{8}$ - 16 (adjustment bolt)	4
	HB-38-16-100	Bolt, $\frac{3}{8}$ - 16 x 1	6
	HW-38	Washer, $\frac{3}{8}$	6
	HNFL-38-16	Flange Lock Nut, $\frac{3}{8}$ -16	6
6	17-579	Boom Center	1
7	30-185	Arm Pivot Hinge	2
	HG-14-28-180	Grease Fitting, $\frac{1}{4}$ - 28 x 180°	2
	76-128	Bushing	4
8	HB-12-13-500	Bolt, $\frac{1}{2}$ - 13 x 5	2
	HNTL-12-13	Lock Nut, $\frac{1}{2}$ - 13	2
9	HB-38-16-175	Bolt, $\frac{3}{8}$ - 16 x $1\frac{3}{4}$	2
	HNFL-38-16	Flange Lock Nut, $\frac{3}{8}$ -16	4
10	17-596	Hinge Pin w/Spacer	2
	HP-18-100	Cotter Pin, $\frac{1}{8}$ x 1	2
11	17-541	Boom End Guard	2
	HBFL-516-18-075	Bolt, $\frac{5}{16}$ - 18 x $\frac{3}{4}$	4
	HNFL-516-18	Flange Lock Nut, $\frac{5}{16}$ - 18	4
12	17-532	Right Boom Arm	1
14	33-506	Body (see nozzle drawing)	12
	HB-516-18-075	Bolt, $\frac{5}{16}$ -18 x $\frac{3}{4}$	12
	HNTL-516-18	Lock Nut, $\frac{5}{16}$ -18	12
15	17-632	Boom Hinge Complete	2
	HB-38-16-100	Bolt, $\frac{3}{8}$ - 16 x 1	16
	HNFL-38-16	Lock Nut, $\frac{3}{8}$ - 16	16
19	17-636	Fresh Water Tank Mount	1
20	17-537	Square U-bolt	1
21	HB-38-16-300	Bolt, $\frac{3}{8}$ - 16 x 3	2
	HNTL-38-16	Lock Nut, $\frac{3}{8}$ - 16	2
22	HB-12-13-300	Bolt, $\frac{1}{2}$ - 13 x 3	2
	HNTL-12-13	Lock Nut, $\frac{1}{2}$ - 13	2
24	17-619	Push in Plug	4
25	18-297	Cap Plug	1
26	18-036	1" Bushing (part of 30-214)	2
27	18-234	$\frac{1}{2}$ " Bushing (part of 30-214)	2
28	17-573	Guide Block Set	2
	HB-14-20-125	Bol $\frac{1}{4}$ -20 x $1\frac{1}{4}$	8
	HNTL-14-20	Lock Nut $\frac{1}{4}$ - 20	8
29	HB-516-18-075	Bolt, $\frac{5}{16}$ - 18 x $\frac{3}{4}$	8
	HW-516	Flat Washer, $\frac{5}{16}$	8
	HNFL-516-18	Flange Lock Nut, $\frac{5}{16}$ - 18	8
30	HB-516-18-100	Bolt, $\frac{5}{16}$ -16 x 1	8
	HW-516	Flat Washer, $\frac{5}{16}$	4
	HNTL-516-18	Lock Nut, $\frac{5}{16}$ - 18	8

(Continue on next page)

17-580 20' BOOM DRAWING

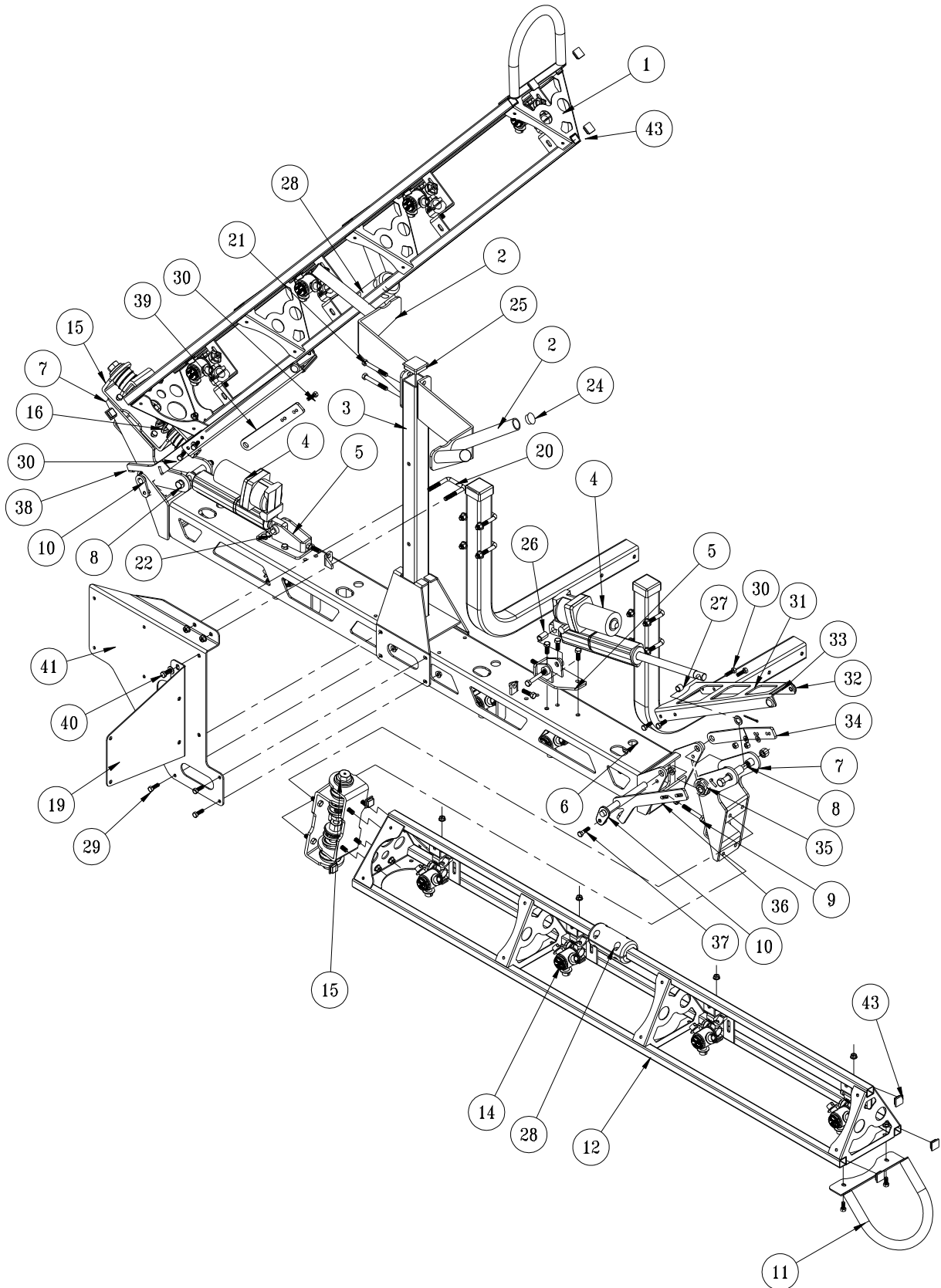

Accessories

17-580 20' BOOM PARTS LIST

REF#	PART#	DESCRIPTION	QUANTITY
31	17-587	Boom Lock	2
32	42-116	Rubber Insert	4
33	8803-2.75	Trim Lace, 2 ³ / ₄	2
34	17-588	Lock Hinge, RH	1
35	17-597	Torsion Spring, RH	1
36	17-589	Limit Hinge, RH	1
37	HB-516-18-100	Bolt, ⁵ / ₁₆ -16 x 1	2
	HNFL-516-18	Flange Lock Nut, ⁵ / ₁₆ - 18	2
38	17-593	Limit Hinge, LH	1
	17-598	Torsion Spring, LH	1
39	17-592	Lock Hinge, LH	1
40	HB-38-16-100	Bolt, ³ / ₈ - 16 x 1	2
	HNFL-38-16	Flange Lock Nut, ³ / ₈ - 16	2
	HW-38	Washer, ³ / ₈	2
41	17-635	Clean Load Mount	1
	8803-13	Black Trim, 13"	1
43	30-258	1" 10-14ga Ribbed Plug	10

BOOM MOUNT TO TRUCK

REF#	PART#	DESCRIPTION	QUANTITY
A		Center Boom Mount	1
B	17-614	Boom Spacer	2
C	HB-516-18-100	Bolt, ⁵ / ₁₆ -18 x 1	12
	HNTL-516-18	Lock Nut, ⁵ / ₁₆ -18	12
D	20-555	U-Bolt	4
	HNFL-12-13	Flange Lock Nut, ¹ / ₂ - 13	8

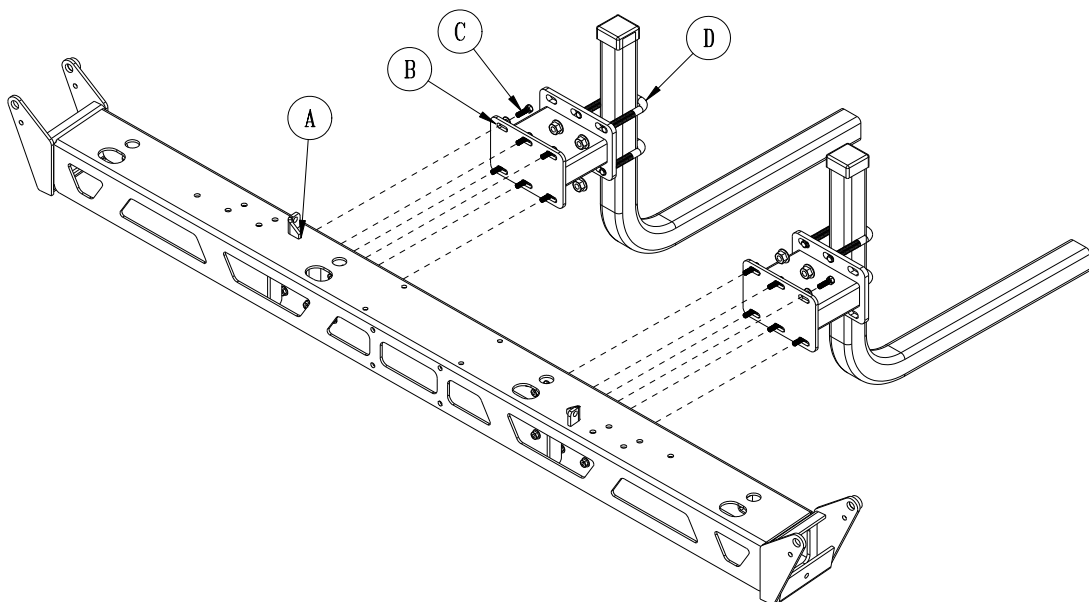

17-585 18' HD SUPER BOOM PLUMBING

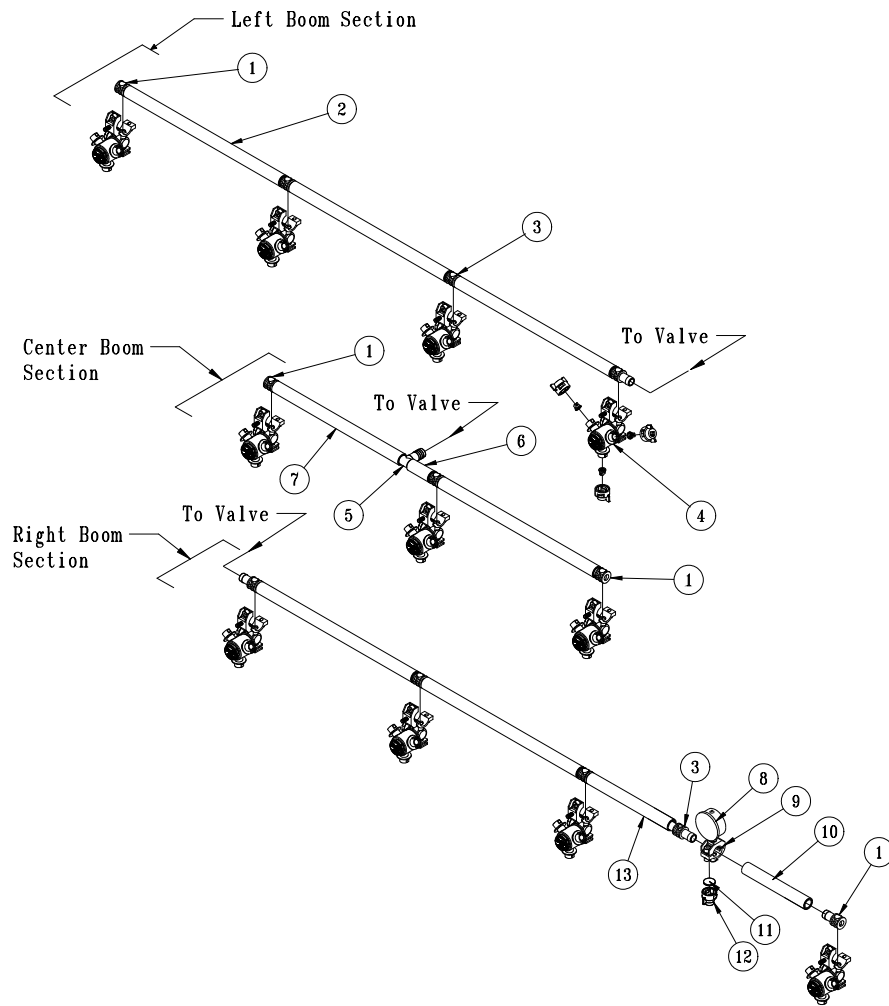

REF#	PART#	DESCRIPTION	QUANTITY
1	18-417	Single Barb	4
2	8887-19	Orange PVC Hose $\frac{3}{4}$ " x 19"	6
	18-040	Hose Clamp	12
3	18-416	Double Barb	8
4	33-506	Nozzle body (see nozzle drawing)	11
5	18-415	$\frac{3}{4}$ " Hose Barb	1
6	8887-2.5	Orange PVC Hose $\frac{3}{4}$ " x 2 $\frac{1}{2}$ "	1
	18-040	Hose Clamp	2
7	8887-15.5	Orange PVC Hose $\frac{3}{4}$ " x 15 $\frac{1}{2}$ "	1
	18-040	Hose Clamp	2
8	16-281	Gauge	1
9	17-602	Nozzle Body	1
10	8887-5	Orange PVC Hose $\frac{3}{4}$ " x 5"	1
	18-040	Hose Clamp	2
11	16-800	Strainer	1
12	16-921	Nozzle	1
13	8887-13	Orange PVC Hose $\frac{3}{4}$ " x 13"	1
	18-040	Hose Clamp	2

17-580 20' HD SUPER BOOM PLUMBING

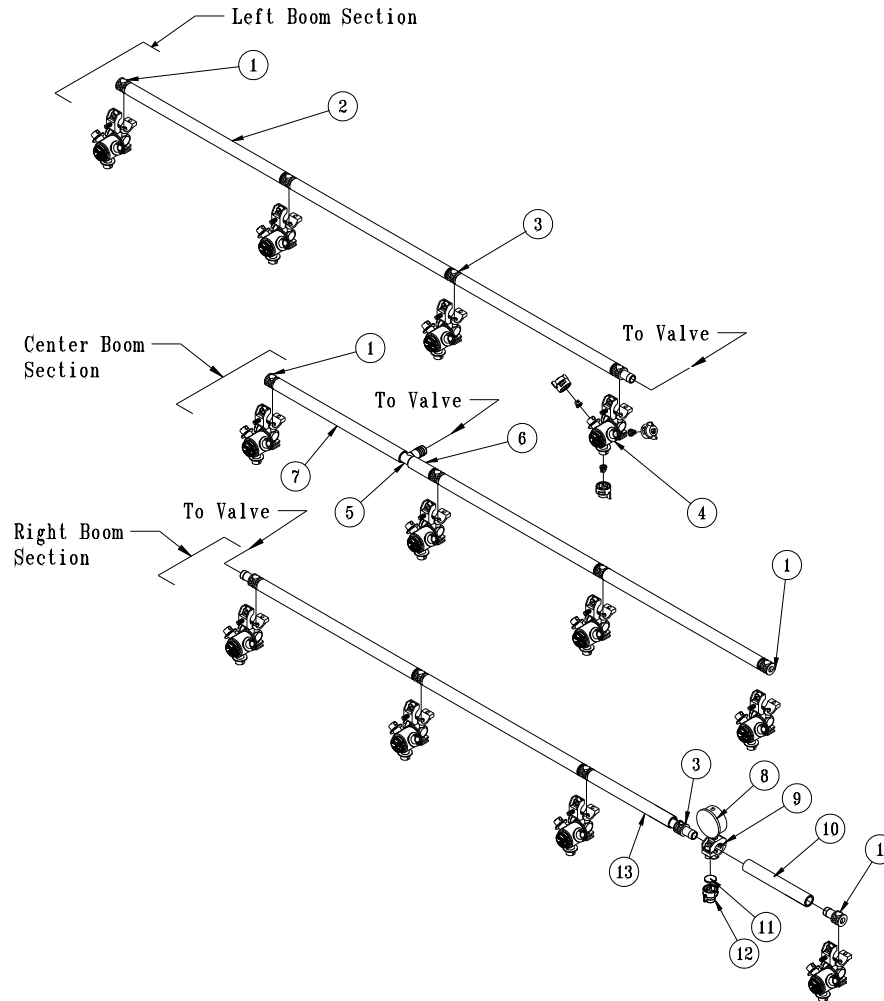

REF#	PART#	DESCRIPTION	QUANTITY
1	18-417	Single Barb	4
2	8887-19	Orange PVC Hose $\frac{3}{4}$ " x 19"	7
	18-040	Hose Clamp	14
3	18-416	Double Barb	9
4	33-506	Nozzle body (see nozzle drawing)	12
5	18-415	$\frac{3}{4}$ " Hose Barb	1
6	8887-2.5	Orange PVC Hose $\frac{3}{4}$ " x 2 $\frac{1}{2}$ "	1
	18-040	Hose Clamp	2
7	8887-15.5	Orange PVC Hose $\frac{3}{4}$ " x 15 $\frac{1}{2}$ "	1
	18-040	Hose Clamp	2
8	16-281	Gauge	1
9	17-602	Nozzle Body	1
10	8887-5	Orange PVC Hose $\frac{3}{4}$ " x 5"	1
	18-040	Hose Clamp	2
11	16-800	Strainer	1
12	16-921	Nozzle	1
13	8887-13	Orange PVC Hose $\frac{3}{4}$ " x 13"	1
	18-040	Hose Clamp	2

Accessories

17-585 18' HEAVY BOOM

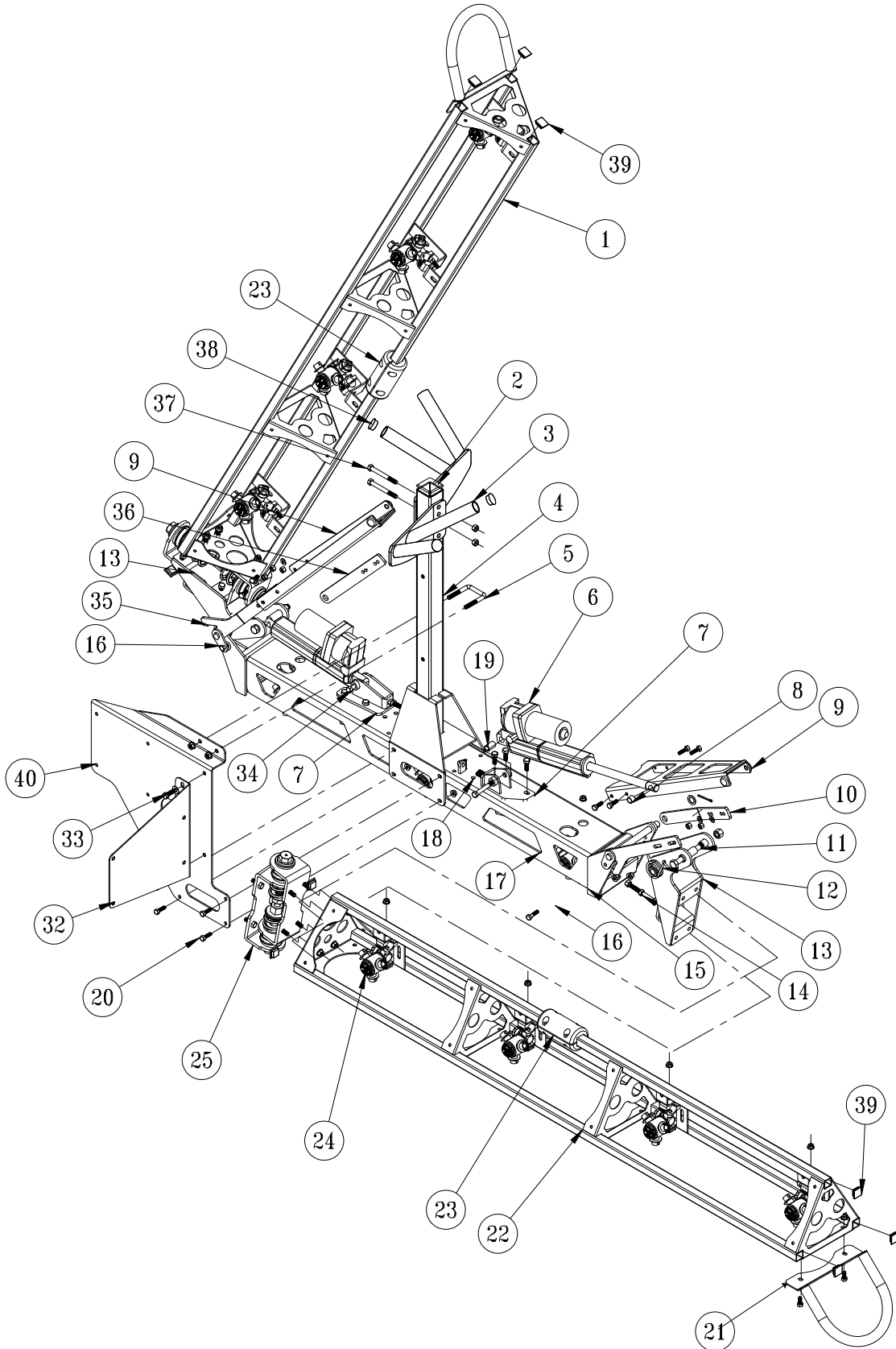

Accessories

17-585 18' HEAVY BOOM

REF#	PART#	DESCRIPTION	QUANTITY
1	17-531	Left Boom Arm	1
2	18-297	Cap Plug	1
3	17-617	Boom Nest	2
4	17-578	Boom Nest Post	1
5	17-537	Square U-bolt	1
6	30-214	KYB Electric/ Hydraulic Actuator (includes * items)	2
7	30-184	Ram Mount	2
	HN-38-16	Nut, $\frac{3}{8}$ - 16 (for adjustment bolts)	4
	HB-38-16-100	Bolt, $\frac{3}{8}$ - 16 x 1	6
	HW-38	Washer, $\frac{3}{8}$	6
	HNFL-38-16	Flange Lock Nut, $\frac{3}{8}$ -16	6
8*	18-036	$\frac{1}{2}$ " Bushing (part of 30-214)	2
9	17-587	Boom Lock	2
	HB-516-18-100	Bolt, $\frac{5}{16}$ - 18 x 1	8
	HW-516	Flat Washer, $\frac{5}{16}$	4
	HNTL-516-18	Lock Nut, $\frac{5}{16}$ -18	8
	42-116	Rubber Insert	4
	8803-2.75	Trim Lace, 2.75"	2
10	17-588	Lock Hinge, RH	1
11	HB-12-13-500	Bolt, $\frac{1}{2}$ - 13 x 5	2
	HNTL-12-13	Lock Nut, $\frac{1}{2}$ - 13	2
12	17-597	Torson Spring, RH	1
13	30-185	Arm Pivot Hinge	2
	HG-14-28-180	Grease Fitting, $\frac{1}{4}$ - 28 x 180°	2
	76-128	Bushing (part of 30-185)	4
14	HB-38-16-175	Bolt, $\frac{3}{8}$ - 16 x $1\frac{3}{4}$	2
	HNFL-38-16	Flange Lock Nut, $\frac{3}{8}$ - 16	4
15	17-589	Limit Hinge, RH	1
16	17-596	Hinge Pin w/ Spacer	2
	HP-18-100	Cotter Pin $\frac{1}{8}$ x 1	2
	HB-516-18-100	Bolt, $\frac{5}{16}$ - 18 x 1	2
	HNFL-516-18	Flange Lock Nut, $\frac{5}{16}$ -18	2
17	17-528	Boom Center	1
19*	18-234	1" Bushing (part of 30-214)	2
20	HB-516-18-100	Bolt, $\frac{5}{16}$ - 18 x 1	8
	HW-516	Washer, $\frac{5}{16}$	8
	HNFL-516-18	Flange Lock Nut, $\frac{5}{16}$ - 18	8
21	17-541	Boom End Guard	2
	HBFL-516-18-075	Bolt, $\frac{5}{16}$ - 18 x $\frac{3}{4}$	4
	HNFL-516-18	Flange Lock Nut, $\frac{5}{16}$ - 18	4
22	17-532	Right Boom Arm	1
23	17-573	Guide Block Set	2
	HB-14-20-125	Bolt $\frac{1}{4}$ - 20 x $1\frac{1}{4}$	8
	HNTL-14-20	Lock Nut $\frac{1}{4}$ - 20	8
24	33-506	Body	11
	HB-516-18-075	Bolt, $\frac{5}{16}$ -18 x $\frac{3}{4}$	11
	HNTL-516-18	Lock Nut, $\frac{5}{16}$ -18	11
25	17-632	Boom Hinge Complete	2
	HB-38-16-100	Bolt, $\frac{3}{8}$ - 16 x 1	16
	HNFL-38-16	Lock Nut, $\frac{3}{8}$ - 16	16

(Continue on next page)

17-585 18' HEAVY BOOM

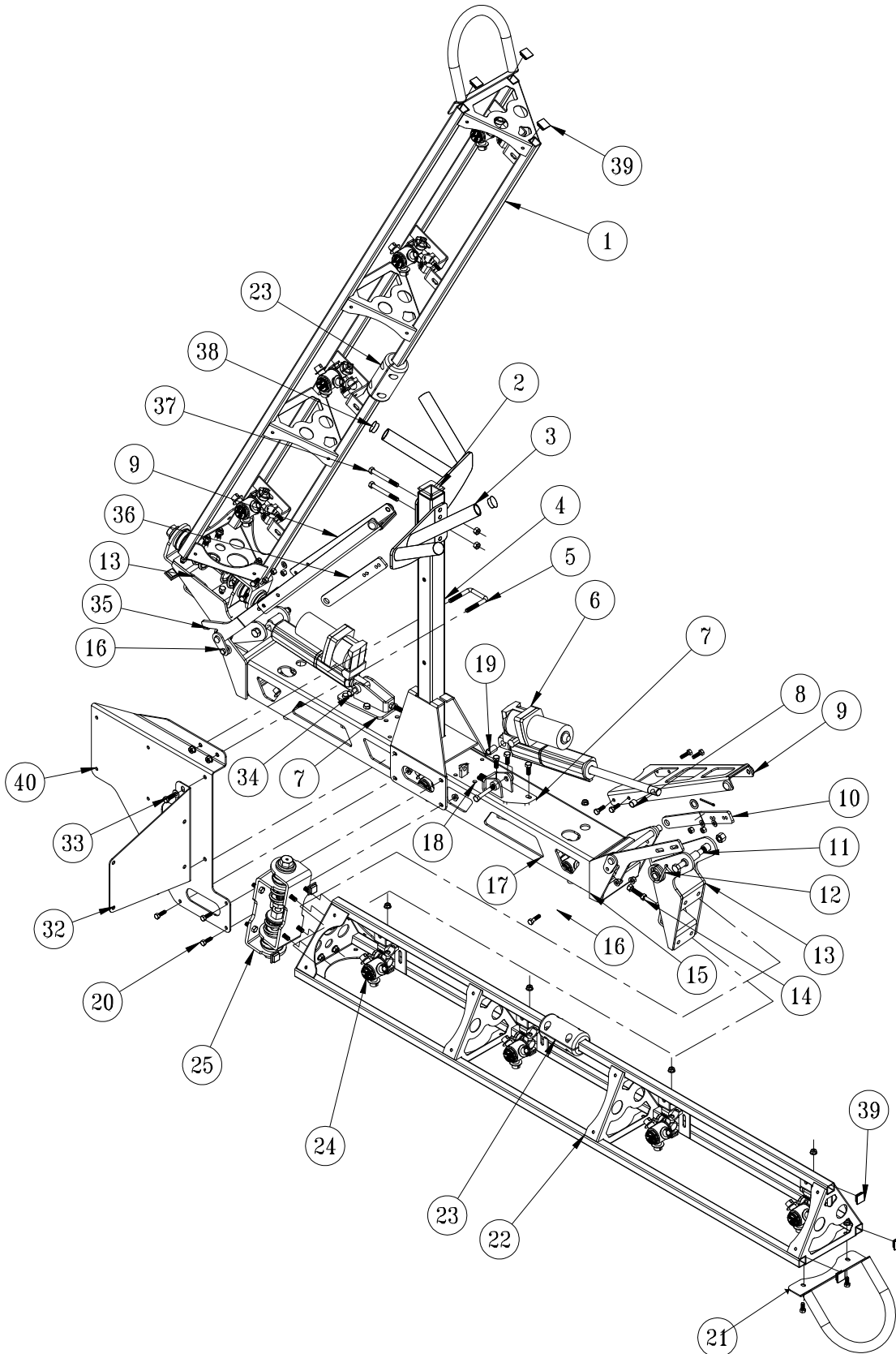

Accessories

17-585 18' HEAVY BOOM

REF#	PART#	DESCRIPTION	QUANTITY
32	17-636	Fresh Water Tank Mount	1
33	HB-38-16-100	Bolt, $\frac{3}{8}$ - 16 x 1	2
	HNFL-38-16	Flange Lock Nut, $\frac{3}{8}$ - 16	2
	HW-38	Washer, $\frac{3}{8}$	2
34	HB-12-13-300	Bolt, $\frac{1}{2}$ - 13 x 3	2
	HNTL-12-13	Lock Nut, $\frac{1}{2}$ - 13	2
35	17-593	Limit Hinge, LH	1
	17-598	Torsion Spring, LH	1
36	17-592	Lock Hinge, LH	1
37	HB-38-16-300	Bolt, $\frac{3}{8}$ - 16 x 3	2
	HNTL-38-16	Lock Nut, $\frac{3}{8}$ - 16	2
38	17-619	Tube Cap	4
39	30-258	Ribbed 1" Plug	10
40	17-635	Clean Load Mount	1
	8803-13	BLack Trim- 13"	1

BOOM MOUNT TO TRUCK

REF#	PART#	DESCRIPTION	QUANTITY
A		Center Boom Mount	1
B	17-614	Boom Spacer	2
C	HB-516-18-100	Bolt, $\frac{5}{16}$ - 18 x 1	12
	HNTL-516-18	Lock Nut, $\frac{5}{16}$ - 18	12
D	20-555	U-Bolt	4
	HNFL-12-13	Flange Lock Nut, $\frac{1}{2}$ - 13	8

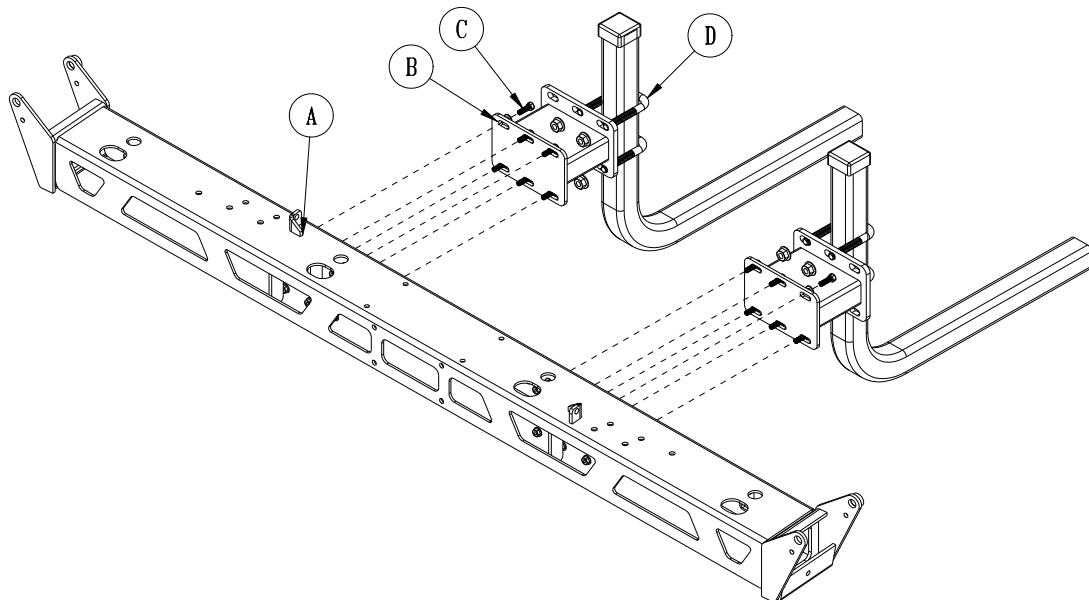

TRIPLE NOZZLE ASSEMBLY

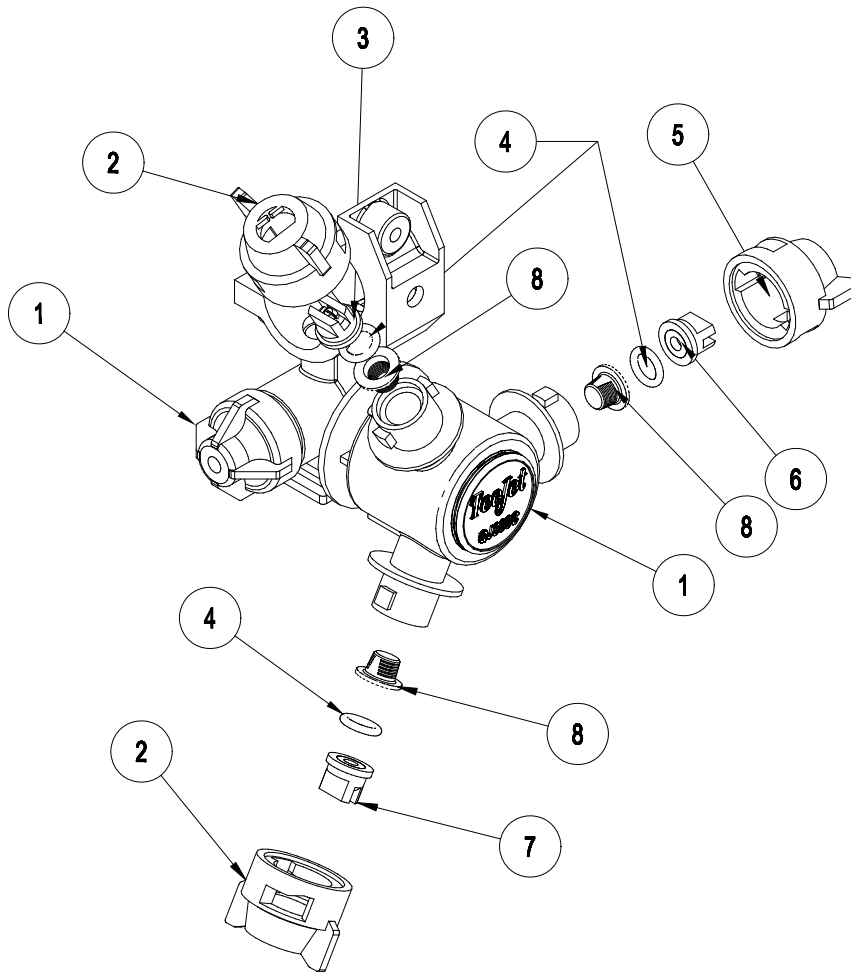

REF#	PART#	DESCRIPTION	QUANTITY
1	33-506	Body	1
2	33-538	Cap - Gray	2
3	33-553	Nozzle -Gray (XR11006-VS)	1
4	16-800	Viton Gasket	3
5	33-537	Cap - Red	1
6	33-552	Nozzle - Red (XR11004-VS)	1
7	33-554	Nozzle - White (XR11008-VS)	1
8	16-802	Strainer	3

Quantity is per nozzle body. For 20' booms multiply quantity by 12.

Quantity is per nozzle body. For 18' booms multiply quantity by 11.

Nozzles are located 20" (51 cm) apart on the right, left, and center tubes. Nozzles are 20" high off ground.

For reordering Nozzle Kits the following numbers apply

33-540 Triple Nozzle Kit for 18' Booms

33-542 Triple Nozzle Kit for 20' Booms

STAR COMMAND NOZZLE VALVE ASSEMBLY

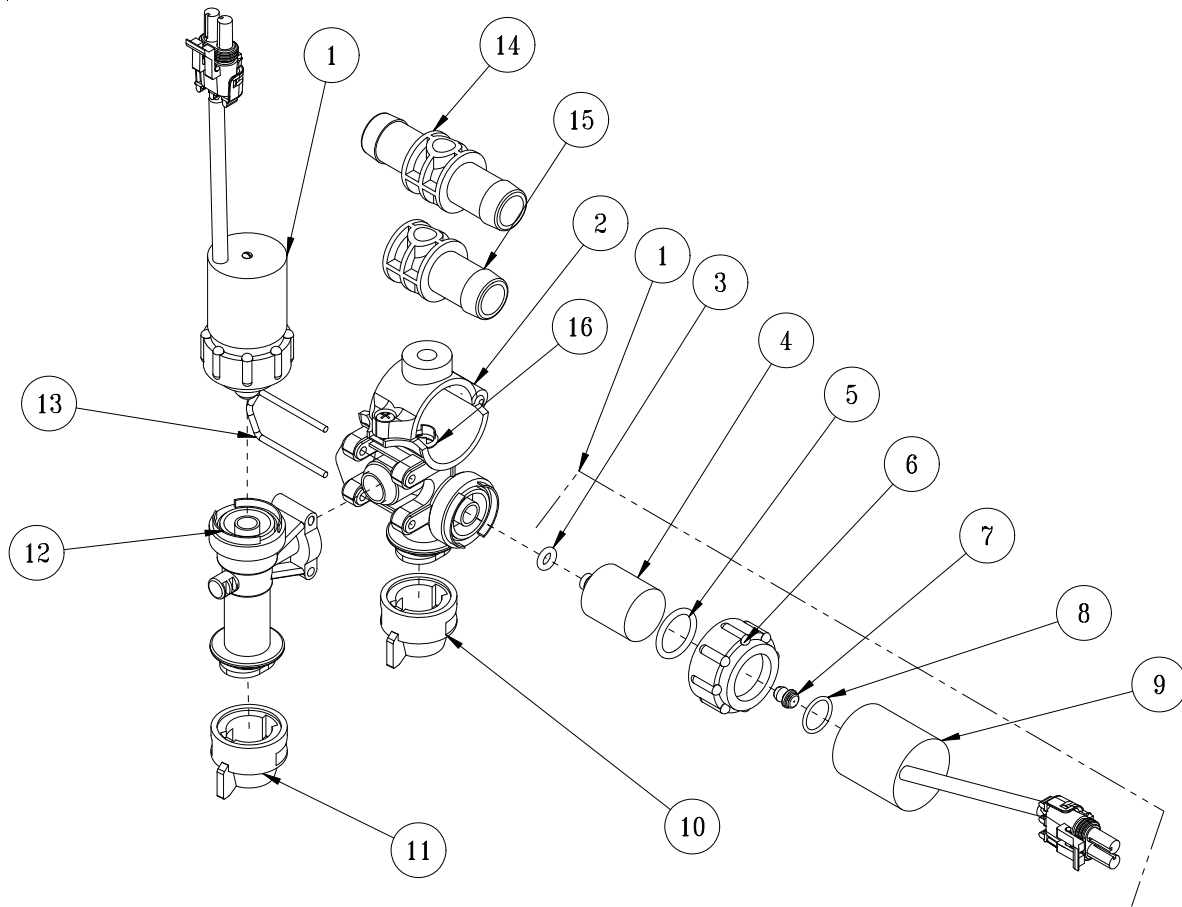

REF#	PART#	DESCRIPTION	QUANTITY
1	30-168-05	Complete Nozzle Valve Assembly (includes * items)	2
2	30-168-12	CR11 Saddle Assembly	1
3*	30-168-20	O-ring	1
4*	30-168-26	Valve Body	1
5*	30-168-18	O-ring	1
6*	30-168-25	Fly Nut	1
7*	30-168-17	Plunger	1
8*	30-168-19	O-ring	1
9*	30-168-21	Coil	1
10	30-168-13	Combo-Jet SR110-10	1
11	30-168-14	Combo-Jet MR110-10`	1
12	30-168-22	End Body Assembly	1
13	30-168-15	Lock U-Clip	1
14	30-170	Double Barb For SharpShooter	1
15	30-169	Single Barb for SharpShooter	1
16	30-168-28	Oring for Double or Singel Barb	1

30-010 ELECTRIC HOSE REEL DRAWING

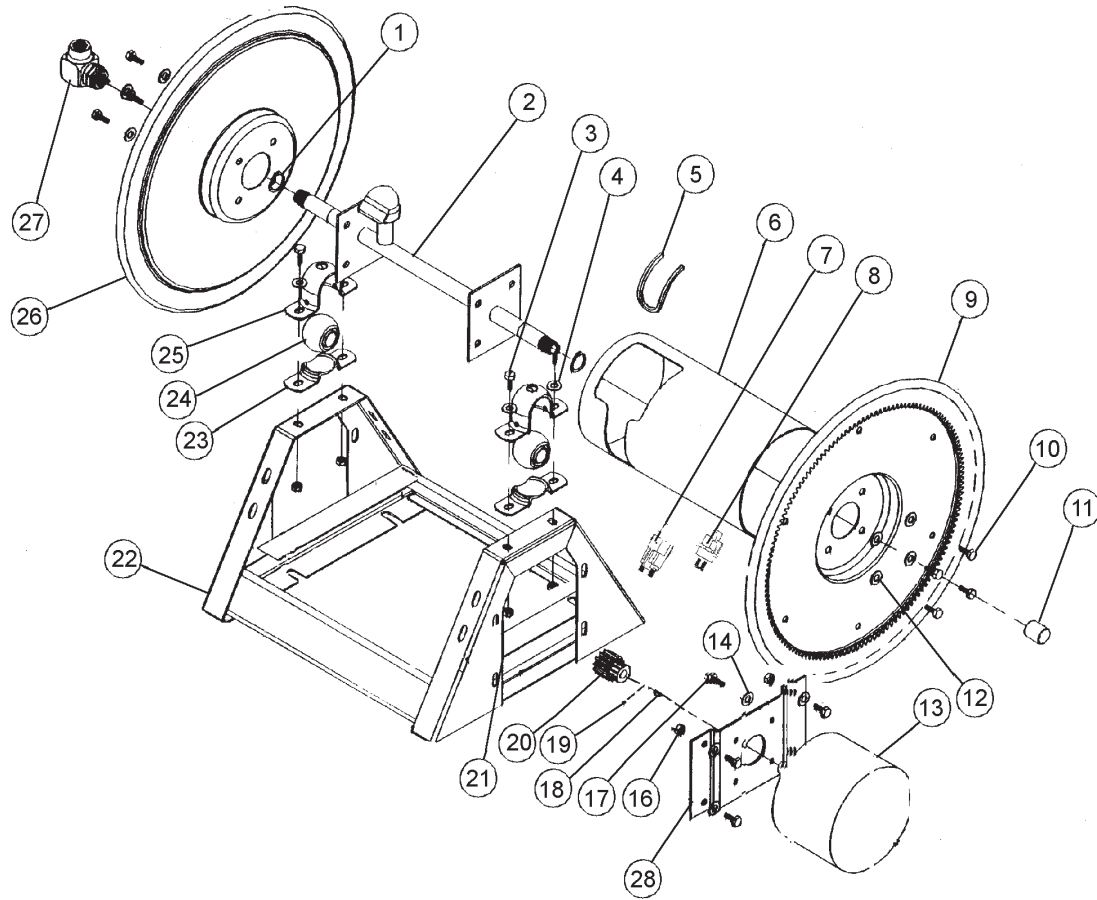

30-010 ELECTRIC HOSE REEL PARTS LIST

REF#	PART#	DESCRIPTION	QUANTITY
1	16-906-25	Retaining Ring	2
2	16-906-22	Axle Assembly	1
3	HB-38-16-100	Bolt $\frac{3}{8}$ - 16 x 1	4
4	HW-38	Washer $\frac{3}{8}$	4
5	16-906-27	Trim, Drum Edge	1
6	16-906-21	Drum Center	1
7	13-750	Solenoid	1
	HB-14-20-075	Bolt $\frac{1}{4}$ - 20 x $\frac{3}{4}$	2
	HWL-14	Lockwasher $\frac{1}{4}$	2
	HN-14-20	Nut $\frac{1}{4}$ - 20	2
8	33-251	Switch	1
9	16-906-19	Disc and Gear Assembly	1
10	HB-516-18-075	Bolt $\frac{5}{16}$ - 18 x $\frac{3}{4}$	8
11	16-906-26	Pipe Cap $\frac{3}{4}$	1
12	HWL-516	Lockwasher $\frac{5}{16}$	8
13		Motor 12VDC	1
14	HW-516	Washer $\frac{5}{16}$	4
16	HNTL-516-18	Lock Nut $\frac{5}{16}$ - 18	4
17	HB-516-18-100	Bolt $\frac{5}{16}$ -18 x 1	4
18	16-906-17	Key	1
19		Set Screw	2
20	16-906-29	Pinion	1
21	HNTL-38-16	Lock Nut $\frac{3}{8}$ - 16	4
22	16-906-18	Frame Assembly	1
23	16-906-08	Mounting Pillow Block (Bottom)	2
24	16-906-24	Bearing	2
25	16-906-07	Mounting Pillow Block (Top)	2
26	16-906-20	Disc 17 $\frac{1}{2}$	1
27	16-906-23	Swivel Assembly $\frac{3}{4}$	1
	16-906-30	Seal Kit (For 16-906-23)	1
28	16-906-28	Bracket 12VDC	1
	16-982	Electric Hose Reel (only)	1

ELECTRIC HOSE REEL WIRING DIAGRAM

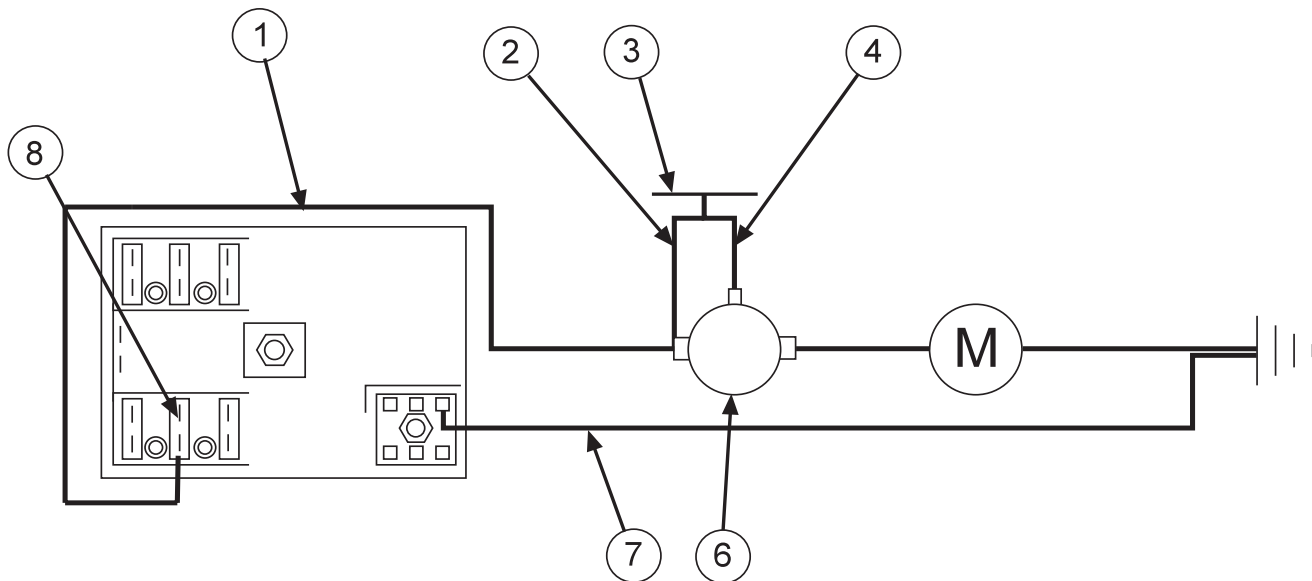

REF#	PART#	DESCRIPTION	QUANTITY
1	8843-132	Flexguard $\frac{3}{8}$ ID	1
	8919-144	10GA Red Wire 144"	1
	8901	Slide-On Connector	1
2	16-979	Wire, Switch to Solenoid Hot Terminal	1
3	33-251	Push Button Switch	1
4	16-978	Wire, Switch to Solenoid Start Terminal	1
6	13-750	Solenoid	1
SOLENOID TERMINALS			
	HN -516-24	$\frac{5}{16}$ - 24 Hex Nut	2
	HN -10-32	10 - 32 Hex Nut	1
7	8931-144	10GA White Wire 144"	1
	8901	Slide-On Connector	1
8	33-273	Auto Blade Type Fuse 30Amp	1

CONNECTION INSTRUCTIONS

Route wire harness along side of tank and over to fuse block taking care to stay clear of moving parts or hot engine components. Cut off excess wire and strip back $\frac{3}{8}$ ". Place one 8963 heat shrink ($\frac{1}{4} \times 1\frac{1}{4}$ ") on each wire before crimping 8901 slide on connectors to the red and white wires. Connect the two wires to the fuse block first the red to the (+) positive and the white to the (-) negative. Put the 33-273 auto blade type fuse (30 amp) into fuse block.



WARNING Make certain you are connecting positive (+) to positive; negative (-) to negative while attaching power leads. If you do not observe polarity, damage will result to electrical components.

Use Dielectric Grease On All Electrical Connections

Accessories

30-009 MANUAL HOSE REEL DRAWING

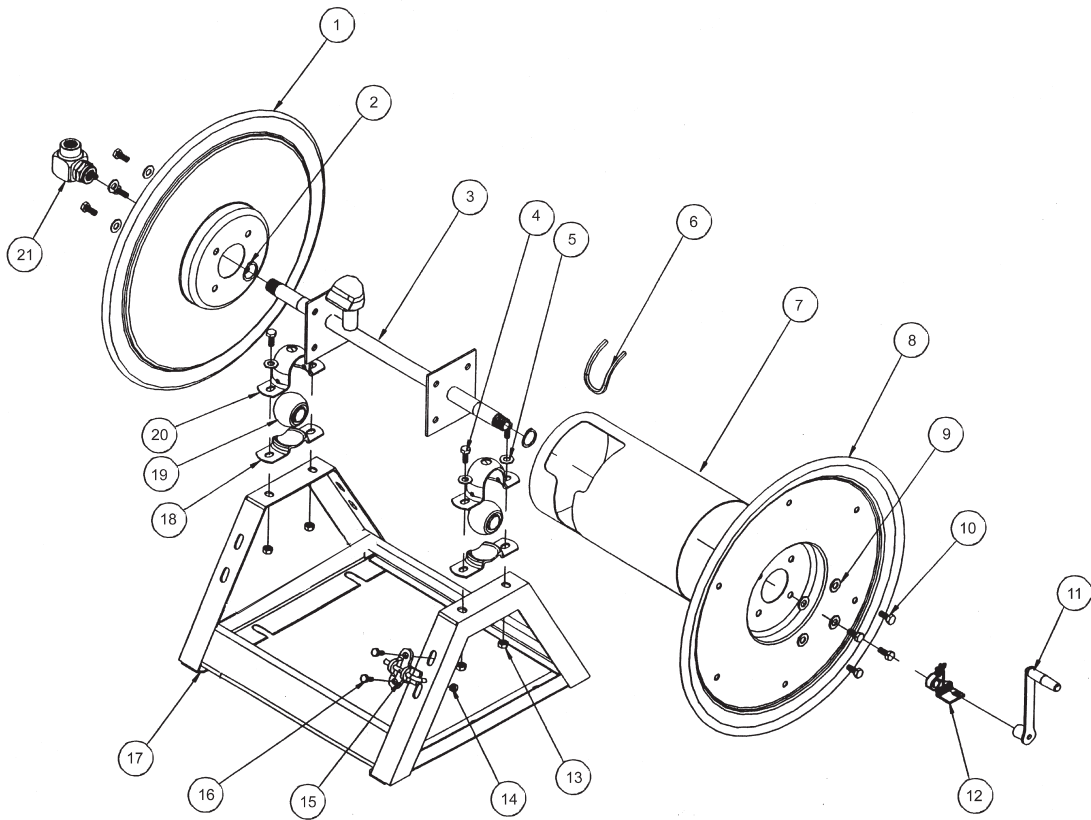

REF#	PART#	DESCRIPTION	QUANTITY
1	16-129-11	Disc 17 $\frac{1}{2}$	1
2	16-906-25	Retaining Ring	2
3	16-906-22	Axle Assembly $\frac{3}{4}$	1
4	HB-38-16-100	Bolt $\frac{3}{8}$ - 16 x 1	4
5	HW-38	Washer $\frac{3}{8}$	4
6	16-906-27	Trim, Drum Edge	1
7	16-906-21	Drum Center	1
8	16-906-20	Disc 17 $\frac{1}{2}$, Crank Side	1
9	HWL-516	Lockwasher $\frac{5}{16}$	8
10	HB-516-18-075	Bolt $\frac{5}{16}$ - 18 x $\frac{3}{4}$	8
11	16-129-09	Crank Assembly $\frac{3}{4}$	1
12	16-129-10	Brake Assembly $\frac{3}{4}$	1
13	HNTL-38-16	Lock Nut $\frac{3}{8}$ - 16	4
14	HNTL-516-18	Lock Nut $\frac{5}{16}$ - 18	2
15	16-129-08	Lock Pin Assembly	1
16	HB-516-18-075	Bolt $\frac{5}{16}$ - 18 x $\frac{3}{4}$	2
	HW-516	Washer $\frac{5}{16}$	2
17	16-129-07	Frame Assembly	1
18	16-906-08	Mounting Pillow Block (Bottom)	2
19	16-906-24	Bearing	2
20	16-906-07	Mounting Pillow Block (Top)	2
21	16-906-23	Swivel Assembly $\frac{3}{4}$	1
	16-906-30	Seal Kit (For 16-906-23)	1

HOSE REEL MOUNT DRAWING

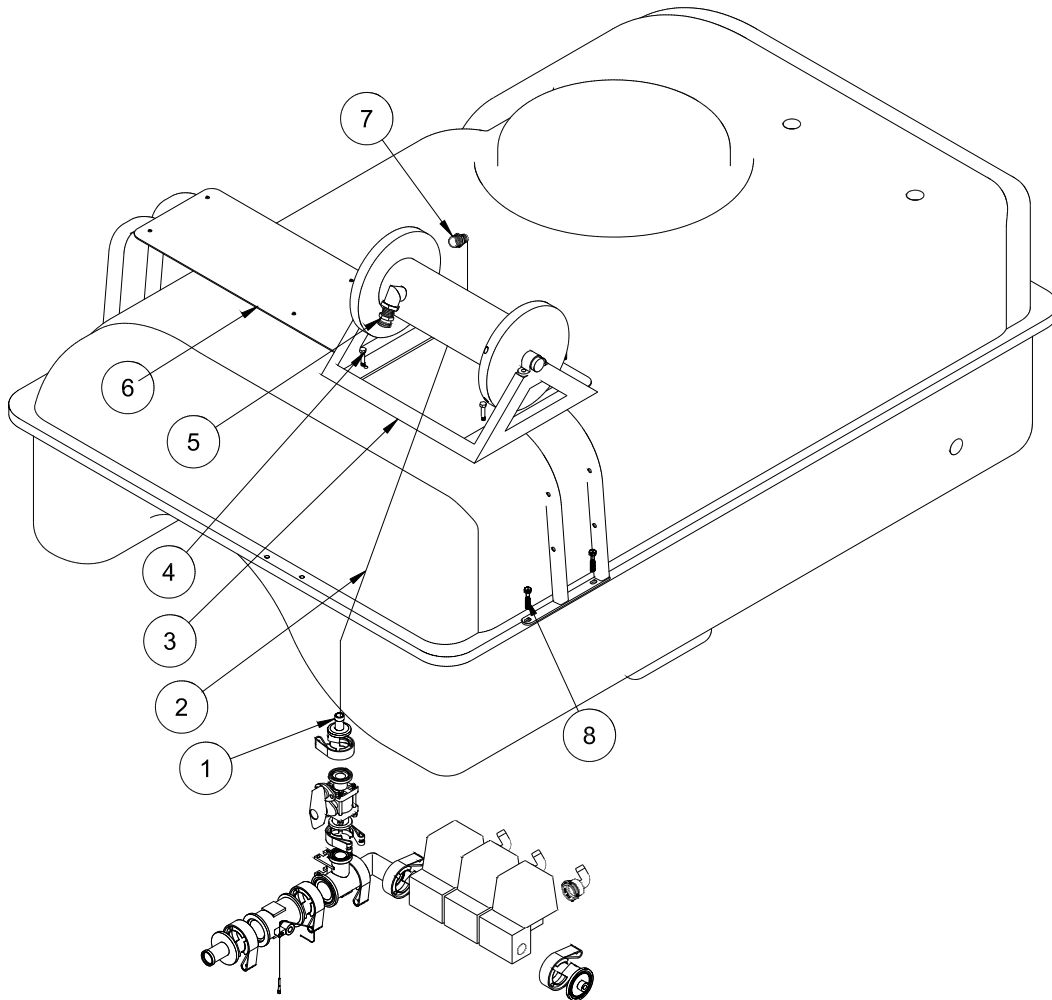

HOSE REEL MOUNT PARTS LIST

REF#	PART#	DESCRIPTION	QUANTITY
1	15-749	Hose Barb $\frac{3}{4}$ "	1
2	8887-110	$\frac{3}{4}$ " Orange PVC Hose 110"	1
	18-040	Hose Clamp	2
3	16-129	Manual Rewind Hose Reel	1
4	HB-516-18-150	Bolt $\frac{5}{16}$ " -18 x $1\frac{1}{2}$ "	4
	HW-516	Washer $\frac{5}{16}$ "	4
	HNTL-516-18	Lock Nut $\frac{5}{16}$ " - 18	4
5	16-295	Hose Fitting $\frac{3}{4}$ "	1
6	30-110	Hose Reel Mount bracket (part of machine)	1
7	18-249	Barb Fitting	1
8	HB-516-18-175	Bolt, $\frac{5}{16}$ " -18 x $1\frac{3}{4}$ " (part of machine)	4
	HNFL-516-18	Flange Lock Nut, $\frac{5}{16}$ " - 18 (part of machine)	4

1. Wear protective clothing when draining the tank and taking apart the lines.
2. Drain tank and spray system in a safe and approved method insuring that no chemical or water remain in tank as you will be taking apart lines.
3. Remove key from ignition, set park brake and block wheels.
4. Put hose reel on hose reel bracket with fitting to the rear of machine. Use four bolts $\frac{5}{16}$ " - 18 x $1\frac{1}{2}$ " and four $\frac{5}{16}$ " - 18 lock nuts to hold in place. Tighten bolts.
5. Put 18-249 barb fitting into hose reel side.
6. Place the 16-295 Hose Fitting into the Hose reel center.
7. Remove the blank cover from the ball valve by the manifold valve and place the 15-749 Hose Barb. Tighten clamp.
8. Route hose from the hose barb on the ball valve to the barb fitting on the side of the hose reel. Hold in place with the two 18-040 clamps.
9. Be sure all clamps and hardware are tight before using.

HOSE REEL ADJUSTMENTS

OPERATIONAL CHECK:

1. Pull hose off drum at least one full revolution. A clicking noise should be heard from locking mechanism.
2. Let the hose retract.
3. Pull the hose off until the first click is heard. Drum should lock when the hose tension is removed.
4. Continue pulling the hose, no more than one revolution, until no clicking is heard. Hose should rewind when tension is removed.

HOSE REPLACEMENT PROCEDURE:

1. Facing swivel, turn the hose drum clockwise until all of the hose is removed from the drum and the drum is held by locking mechanism. Make sure spring is locked.
2. Remove hose clamps and disconnect hose from swivel. Remove old hose.
3. Insert new hose through roller guide, connect to swivel and reinstall hose clamps. Use spring guard over hose to protect the hose from being cut by the drum.
4. Remove check ball from old hose and install on replacement hose.
5. Carefully, keeping the tension on the hose, pull the hose to release the locking mechanism. Let the hose wind on the drum.

30-004 FOAM MARKER DRAWING

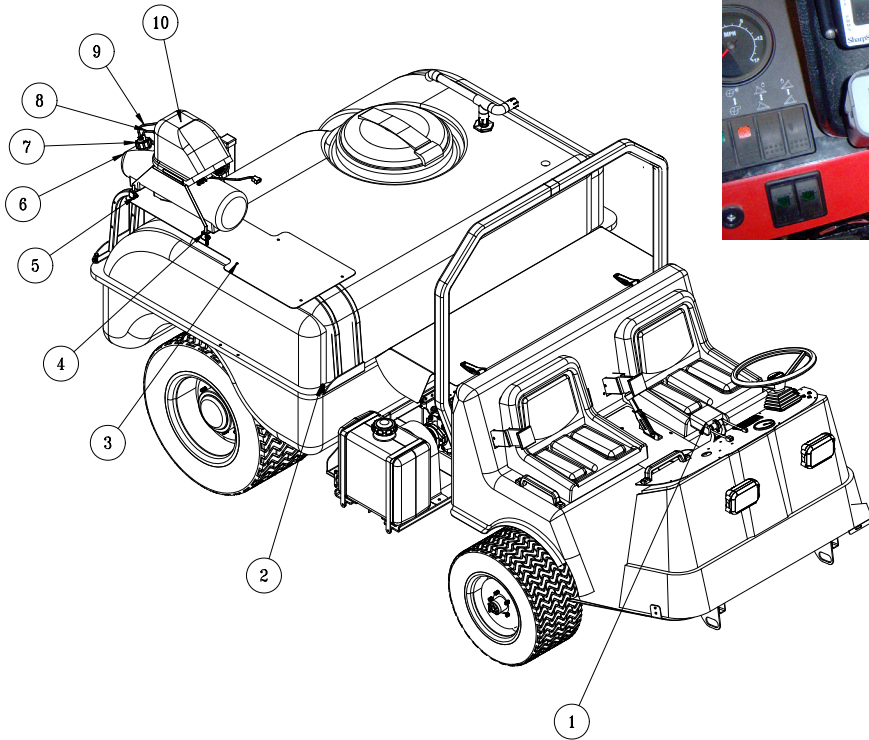

WIRING DRAWING

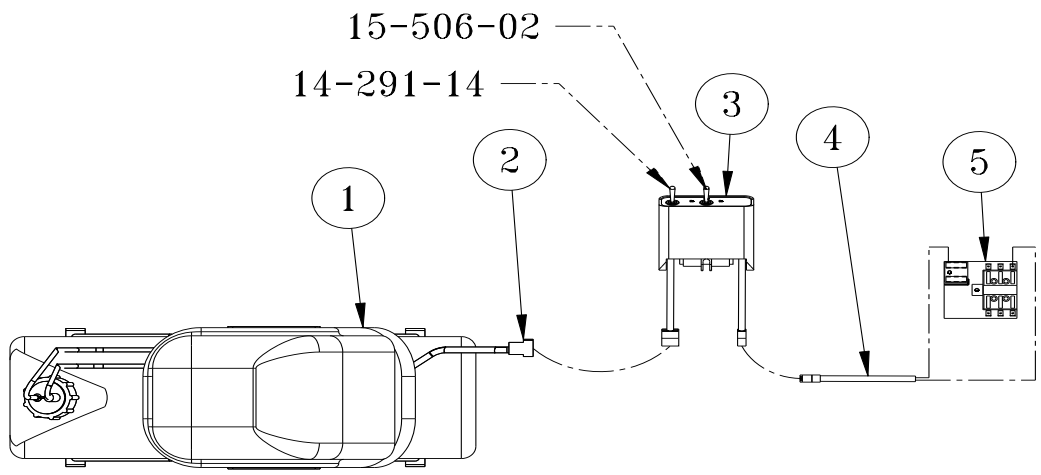

Accessories

30-004 FOAM MARKER PARTS LIST

REF#	PART#	DESCRIPTION	QUANTITY
1*	14-291-05	Double Switch Box	1
	33-508	Fuse	1
	15-506-02	Center Switch	1
	14-291-14	Switch	1
2	HB-516-18-175	Bolt, $\frac{5}{16}$ -18 x $1\frac{3}{4}$ (part of machine)	4
	HNFL-516-18	Flange Lock Nut, $\frac{5}{16}$ - 18 (part of machine)	4
3	30-110	Mount Bracket (part of machine)	1
4*	14-291-04	Tank Bracket	2
5	HN-14-20-075	Hex Bolt, $\frac{1}{4}$ -20 x $\frac{3}{4}$	2
	HBFL-14-20	Flange Lock Nut, $\frac{1}{4}$ -20	2
6*	14-291-02	Foamer Tank	1
7*	14-284-02	Cap Assembly	1
8*		Blue Tube	1
9*		Clear Tube	1
10*	14-291-03	Compressor Only	1
	14-291-01	Black Cover	1
* 	14-291	Foamer (includes * parts)	1

REF#	PART#	DESCRIPTION	QUANTITY
1	14-291-03	Compressor	1
2	15-504-04	Wiring Harness	1
3	14-291-05	Switch Box	1
	33-508	Fuse	1
	15-506-02	Center Switch	1
	14-291-14	Outside Switch	1
4	15-509	Power Cable	1
5	33-271	Fuse Block (part of machine)	1
	33-293	Auto Blade Type Fuse 30 amp	1

30-004 FOAM MARKER DRAWING

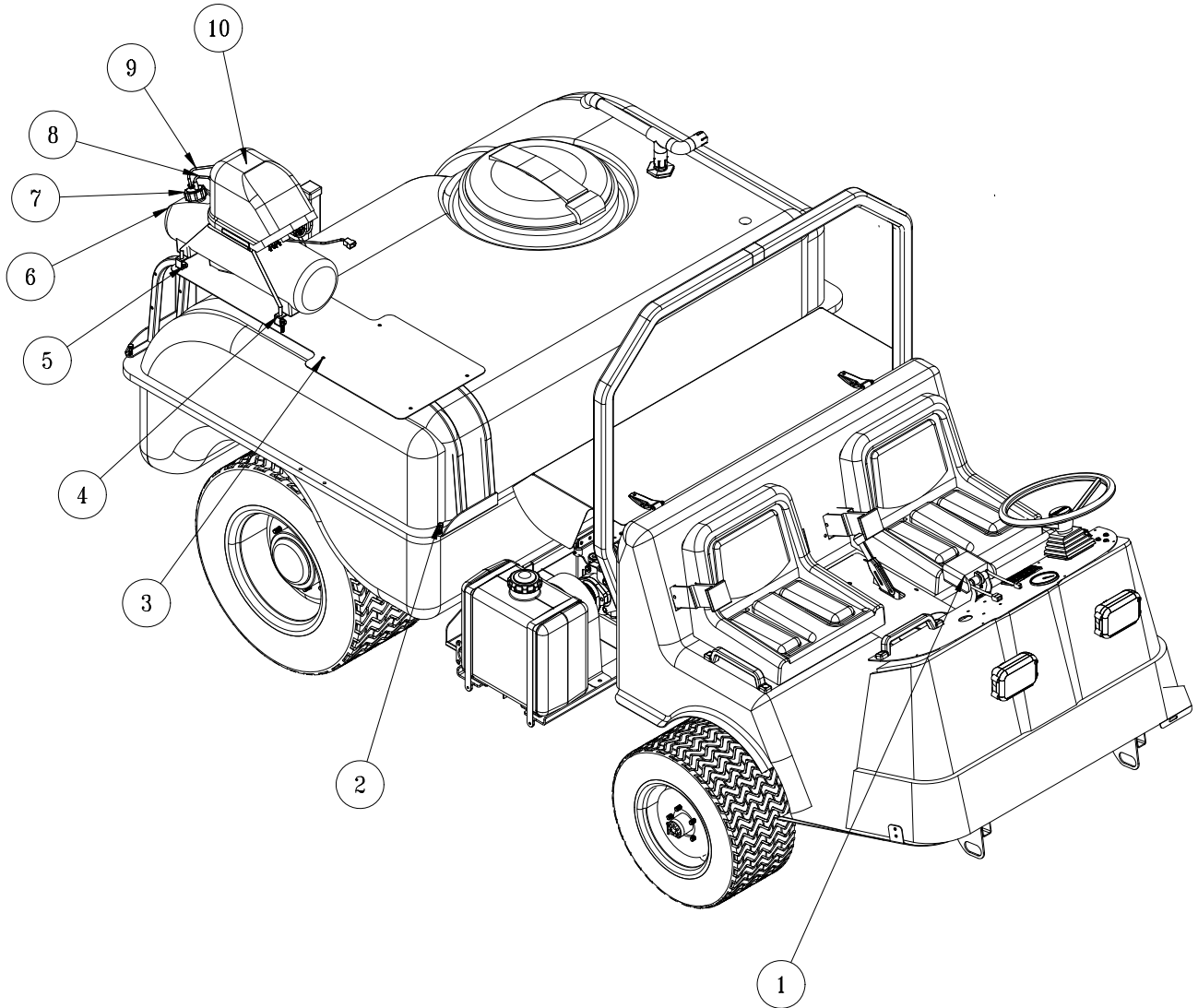

Accessories

INSTALLATION INSTRUCTIONS

Safety: Before working on machine stop engine, set park brake, remove key from ignition and block wheels. Disconnect negative (-) battery terminal.

BOX MOUNT

Mount the switch box to the lower center of the dashboard. Remove the two phillips head bolts. Reinstall the #10 x 1 phillips head bolts and lockwashers to hold the switchbox onto the dashboard. Tighten all bolts.

WIRING

Use dielectric grease on all electrical connections. Connect power cable (15-509) to the switch box. Turn the switch off. Route the power wire down through the grommet in the dashboard. Follow the wire harness down under the floorboard, then back along the main frame and up to the fuse block in the engine compartment behind the passenger seat. The power cable will need to be cut and shortened. Attach slide-on terminals to the wire ends with heat shrink, then connect to fuse block. Red to positive(+), black to negative(-). Insert 10 AMP fuse into slot which has red wire attached to it.

Route Control Harness (15-504) from switch box on dashboard same as the power wire. Only continue all the way to the rear of the machine. Then pull the cable up over the back of the spray tank so it can be connected to the compressor.

CONNECTING THE CAP ASSEMBLY

Connect the blue tube to the tank cap connector which is also connected to the large blue tube which hangs below the cap. This is the soap outlet tube. Connect the clear tube to the other connector on the tank cap. This is the air input tube. Tighten connectors hand tight, assembly tank cap onto tank.

HOSES

Being careful not to cut the tubing, cut the oversleeve back approximately 2" (5 cm) to expose blue and clear tubing. Remove blue wing nut from top connector of foam nozzle and slide it on the blue tube with the threads facing toward end of tube. Slide blue tube all the way over the top of the small tube on foam nozzle. Slide wing nut back to the threads and hand tighten. Follow the same steps for the clear tube and tube nut.

Route the tubing along underside of main frame using tie downs as necessary.

Install opposite ends of air-liquid tubes to compressor, again cutting back the oversleeve approximately 2" (5 cm) and inserting blue and clear tubes for the left boom section into the tubing connectors on the right side of compressor as far as possible. Follow the same steps for the right boom tubing. Notice the right boom is inserted into left side of compressor. To release tubing from compressor, hold black ring around tubing, and pull tube out.

FOAMER NOZZLE MOUNT & HOSE GUARD MOUNT DRAWING

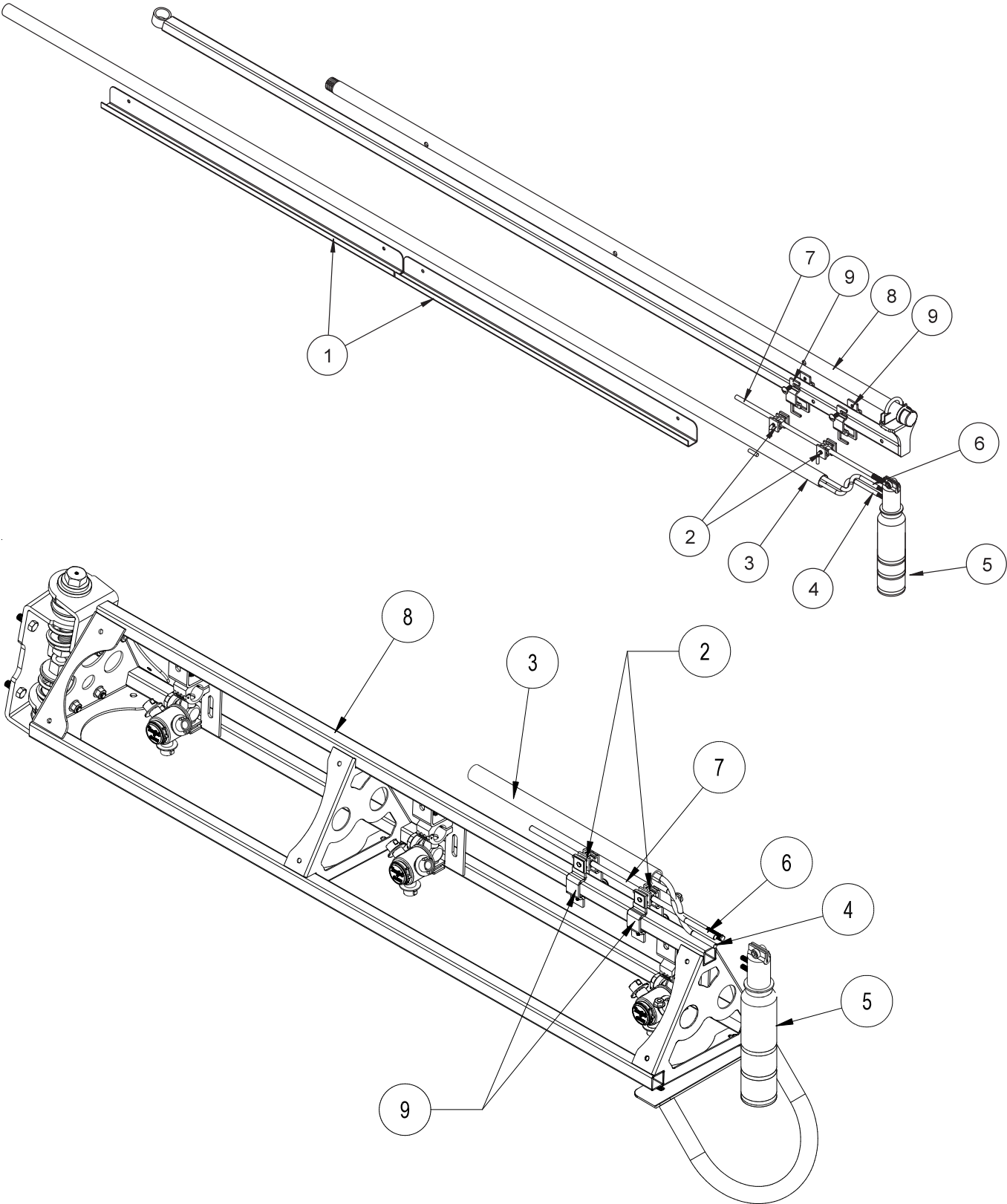

Accessories

30-162 FOAM MARKER PARTS LIST

REF#	PART#	DESCRIPTION	QUANTITY
1	15-537	Foamer Hose Guard 31"	4
	HSDPS-14-075	Stainless Steel Pan Head Drill Screw $\frac{1}{4} \times \frac{3}{4}$	8
2	16-987	Foam Nozzle Mounting Kit	1 per boom
3	15-507	Foamer Tubing	1
4		Clear Tubing	
5	15-511	Foam Nozzle	2
6		Blue Tubing	
7	15-510-01	Nozzle Mounting Rod	2
8		Boom	
9	16-795	Square Clamp	4

- Slide hose clamp onto drop tube of foam nozzle and attach restrictor bell.
- Place splined end of Nozzle mounting rod (Ref 7) into top of foam nozzle (Ref 5). Tighten screw.
- Slide two foam nozzle mounts (Ref 2) onto the rod. Place square clamps (Ref 9) on foam nozzle mounts and mount the square clamps to the boom (Ref 8). Adjust foam nozzle mounts and clamps so nozzle assembly will clear end of boom. Tighten foam nozzle mounts and square clamps to prevent side to side movement. Do the same to the other side.
- Being careful not to cut the tubing (Ref 3), cut the oversleeve back approximately 2" (5 cm) to expose blue (Ref 6) and clear tubing (Ref 4).
- Remove blue wing nut from top connector of foam nozzle and slide it on the blue tube with the threads facing toward end of tube. Slide blue tube all the way over the top of the small tube on foam nozzle. Slide wing nut back to the threads and hand tighten. Follow the same steps for the clear tube and tube nut.
- Route the tubing along underside of main frame using tie downs as necessary.
- Install opposite ends of air-liquid tubes to compressor, again cutting back the oversleeve approximately 2" (5 cm) and inserting blue and clear tubes for the left boom section into the tubing connectors (Ref A) on the right side of compressor as far as possible.
- Follow the same steps for the right boom tubing. Notice the right boom is inserted into left side of compressor. To release tubing from compressor, hold black ring around tubing, and pull tube out.
- Hose's must be routed on bottom of the boom square tubing.
- Mark 6 inches in from inside edge of foamer nozzle mounting bracket on square boom tubing.
- Place hose guard (Ref 1) flush with top of square tubing with edge on previous mark. The channel covers hoses on the bottom of the square tubing.
- Install hose guard using 2 drill screws (you may want to drill a $\frac{3}{16}$ pilot hole first).
- Place another hose guard against first and install in same manner.
- Repeat process for other boom side.
- Connect small plastic electrical plug under compressor to electrical extension cable.
- For *Spray Star 1600* route extension cable under engine along the mainframe cross bar, using tie downs as necessary.
- Cut cable and strip casing, allowing enough length to connect to fuse block.
- Strip and connect slide on connectors to each wire and use the heat shrink.
- Connect black negative (-) wire to the ground and connect red wire to the positive (+).
- Insert 10 amp fuse into slot which red wire was attached to.

FOAM MARKER DRAWING



Accessories

REF#	PART#	DESCRIPTION	QUANTITY
1	15-507	Foamer Tubing	1
2	14-291-02	Tank	1
3	14-291-01	Black Cover	1
	14-536	Compressor Complete	1
4	14-284-02	Cap Assembly	1
5	14-291-04	Tank Bracket	1
6	14-291-05	Double Switch Box	1
7	15-511	Foam Nozzle	1
8	15-510-01	Nozzle Mounting Rod	1
9	16-987	Foam Nozzle Mounting Kit	1
	14-536	Compressor Subassembly	

15-511 FOAM NOZZLE SUB ASSEMBLY DRAWING

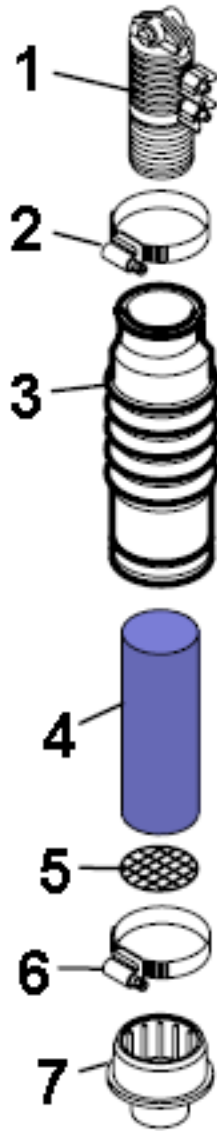

Accessories

REF#	PART#	DESCRIPTION	QUANTITY
1*	15-511-01	Foam Nozzle Inlet Body	1
	15-511-02	Foam Sponge	1
	15-511-10	Plastic Screen	1
2*		Hose Clamp	1
3*		Drop Tube	1
4	15-511-08	Long Foam Sponge	1
5	15-511-09	Stainless Steel Screen	1
6		Hose Clamp	1
7	14-284-09	Foam Nozzle Reducer	1
NS	15-510-01	Nozzle Mounting Rods	2
*	15-511-07	Foam Nozzle Sub Assembly	

14-515 WATER METER KIT (GALLONS)

15-618 WATER METER KIT (LITERS)

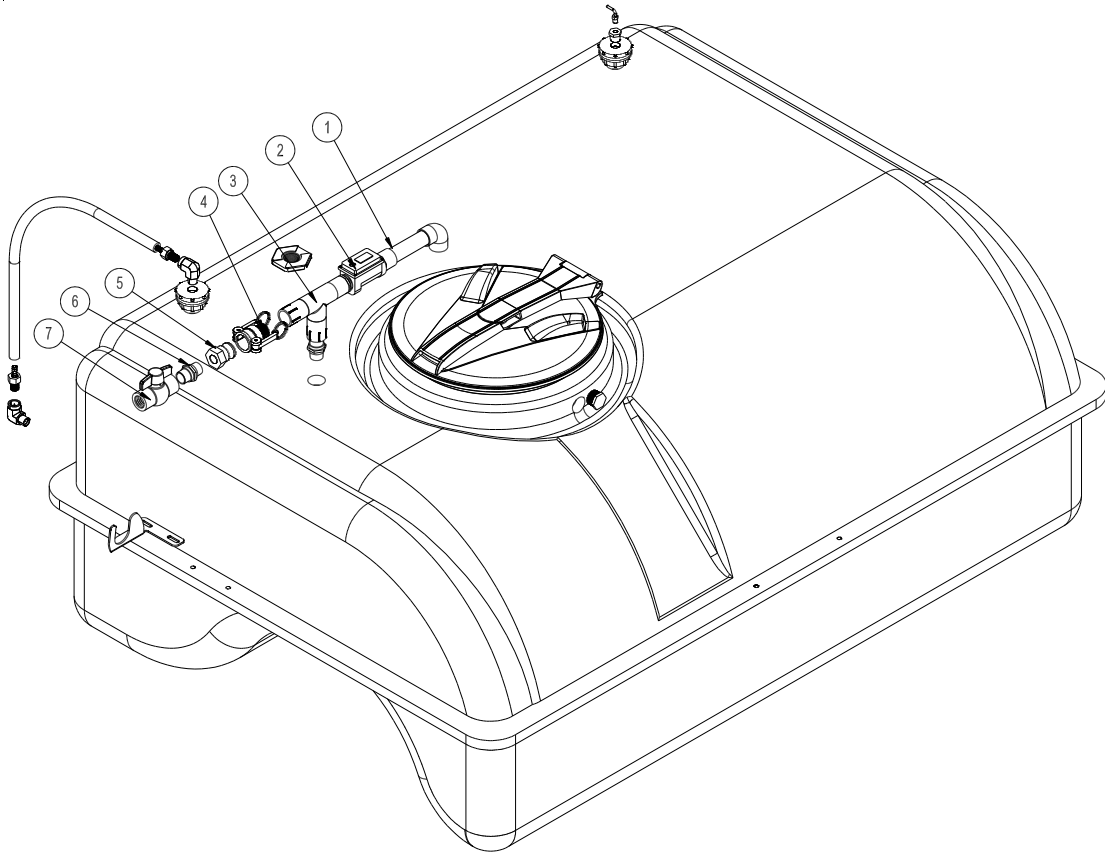

REF #	PART #	DESCRIPTION	QUANTITY
1	14-524	Filler Outlet	1
2	14-514	Water Meter (Gallons)	1
	14-527	Water Meter (Liters)	1
3	14-525	Filler Inlet	1
4	16-962	1" Quick Coupler (already on machine)	1
5	16-961	1" Adapter Quick Coupler (already on machine)	1
6	16-851	1" Nipple	1
7	18-448	1" Ball Valve	1

1. Thoroughly flush the service line upstream of the meter to remove dirt and debris.
2. The DLJ Meter is for use **only** with **COLD WATER** up to 122°F (50°C)
3. Slowly open any upstream valves to prevent damage to the meter.

Gallons to Cubic feet Conversion :

Multiply gallons reading by 0.1337 to get cubic feet.

There are 7.48052 gallon per cubic foot.

30-006 FRESH WATER TANK DRAWING

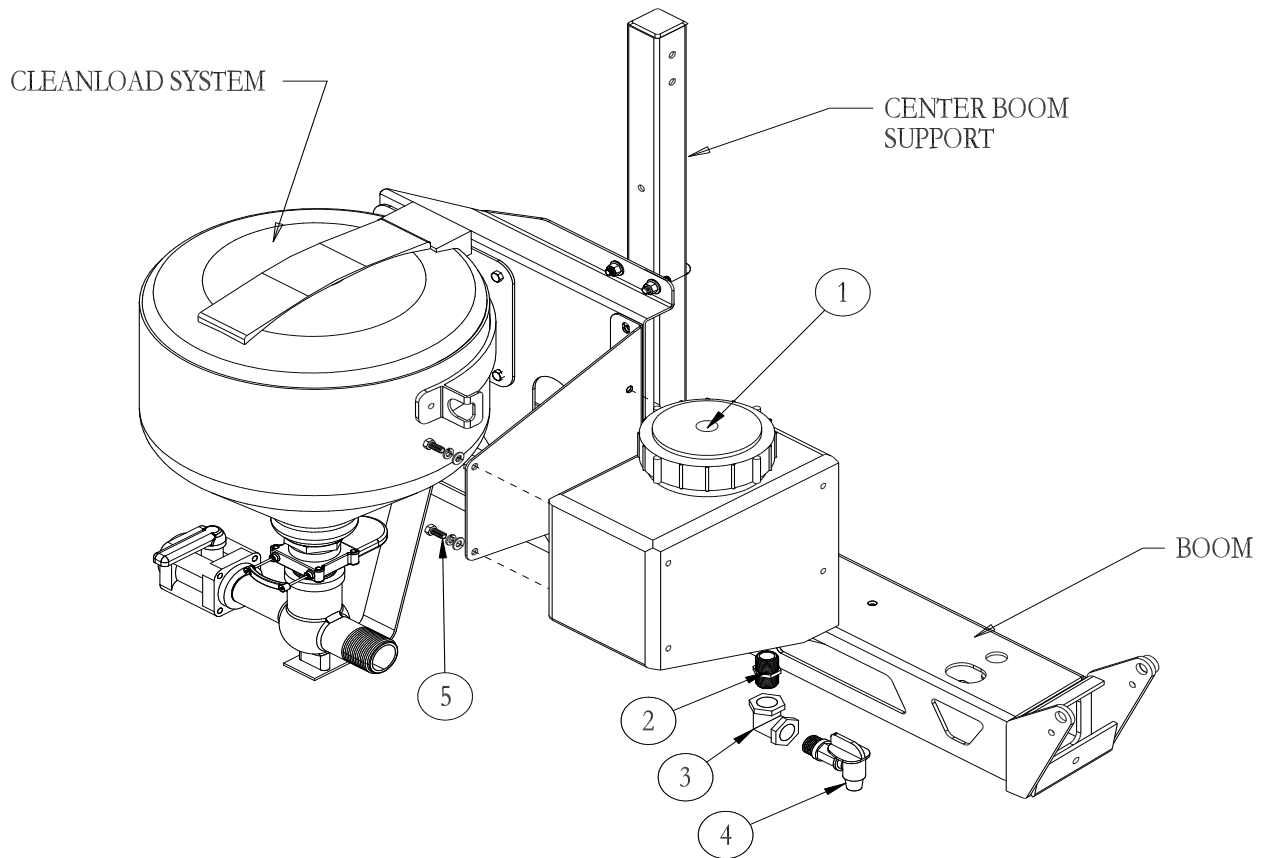

30-006 FRESH WATER TANK PARTS LIST

REF#	PART#	DESCRIPTION	QUANTITY
1	10-234	Wash Tank	1
2	16-158	Close Nipple	1
3	16-151	Elbow	1
4	16-960	Spigot	1
5	HB-516-18-075	Bolt $\frac{5}{16}$ - 18 x $\frac{3}{4}$	4
	HWL-516	Lockwasher $\frac{5}{16}$	4
	HW-516	Washer $\frac{5}{16}$	4

INSTALLATION INSTRUCTIONS

1. Fresh Water Wash Tank mounts on the rear of all the machines.
2. The Bracket is already attached to the Super Boom center boom post.
3. Install the nipple (Ref 2), elbow (Ref 3) and spigot (Ref 4) into the bottom of wash tank (Ref 1). Use thread tape on all threads.
4. Mount the tank onto the mount bracket using four $\frac{5}{16}$ x $\frac{3}{4}$ bolts, washers and lockwashers. Tighten.
5. Rinse tank with clear water and check for leaks around fittings.



This tank is for fresh clear water ONLY. Do not put chemicals in this tank.

30-007 CHEMICAL CLEANLOAD DRAWING

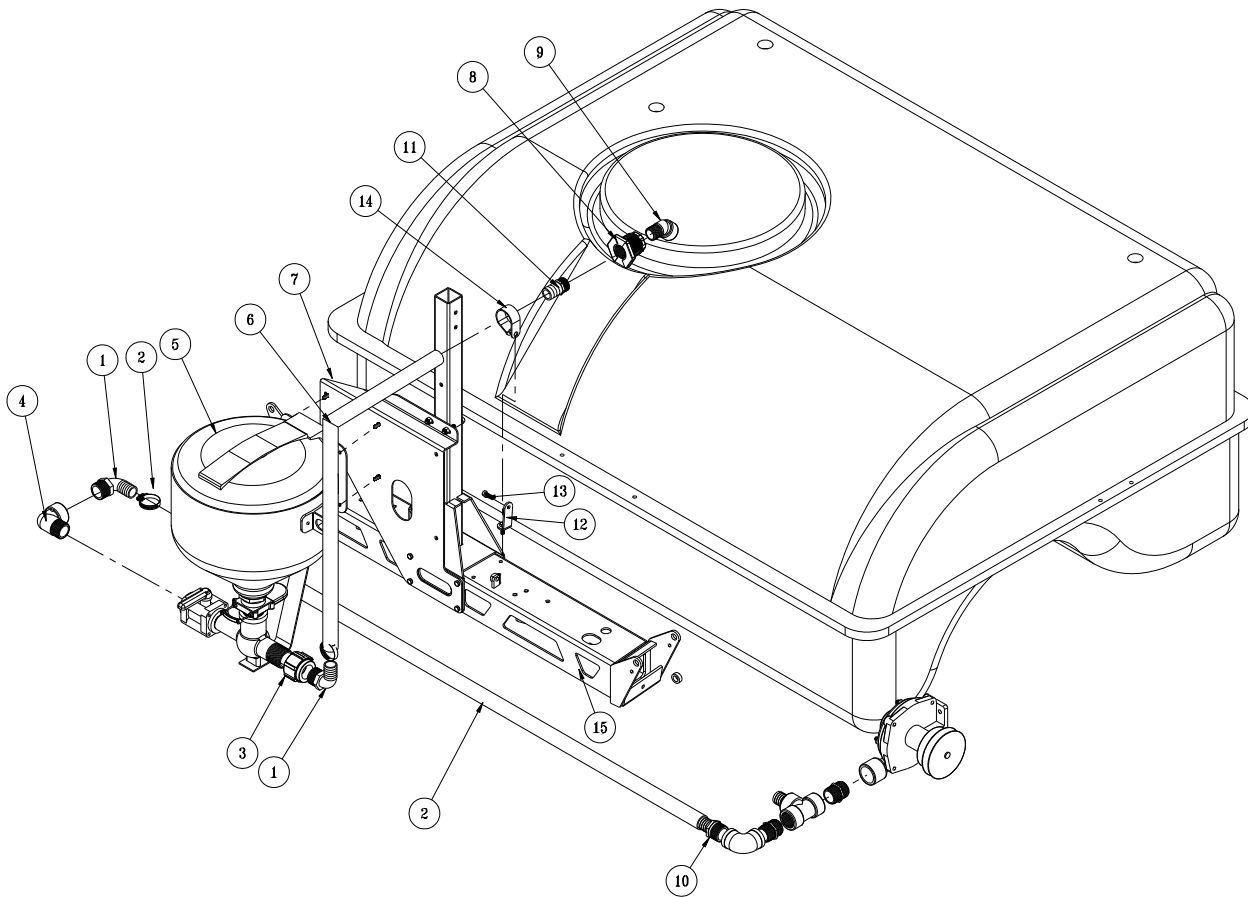

REF#	PART #	DESCRIPTION	QUANTITY
1	16-156	Elbow	2
2	8897-125	1 1/4" Discharge Hose 125"	1
	18-116	Hose Clamp	2
3	18-391	Coupling	1
4	16-972	90° Elbow	1
5	15-620	Cleanload Assembly	1
6	8897-43	1 1/4" Discharge Hose 43"	1
	18-116	Hose Clamp	2
7	17-635	Clean Load Mount (part of boom)	1
8	16-945	Fitting (part of tank)	1
9	16-971	45° Elbow (part of tank)	1
10	16-161	Fitting	1
11	16-159	Hose Barb	1
12	14-604	Loom Clamp Mount	1
13	HB-516-18-100	Bolt 5/16 - 18 x 1	2
	HNFL-516-18	Flange Lock Nut 5/16 - 18	2
14	HLC-A-200	Loom Clamp	1
15		Center Boom	1

Accessories

START-UP

1. All Cleanload valves must be closed prior to starting: inlet ball valve, knife valve and hopper rinse ball valve.
2. Open lid to check for foreign objects which may hinder performance or contaminate the system.
3. Close and lock lid by turning cover clockwise.
4. Divert pump flow to Cleanload inlet line. A pressure of 30 PSI minimum and 150 PSI maximum must be used. Highest pressures increase education rate and available wand suction.
5. Turn inlet ball valve on (yellow handle).
6. Open knife valve, located on the bottom of hopper, by pushing handle in (red handle).
7. Unlock and open lid slowly by turning cover counterclockwise.

LOADING LIQUID OR POWDERED CHEMICAL INTO HOPPER

8. Pour required amount of chemical into hopper. Avoid splashing liquids or powdered chemicals outside of hopper.
9. Rinse empty chemical containers if applicable. Place container opening over container rinse valve and press down. This will activate the rinse valve and rinse container.
10. Rinse Cleanload hopper. Close and lock lid by turning cover clockwise. Release the safety locking band on the hopper rinse ball valve and turn on for 20 seconds. Close ball valve and return locking band to locked position.
11. Open lid and inspect for chemical residue. Repeat step 10 as necessary.
12. Close knife valve by pulling red handle out towards you. Turn inlet (yellow handle) off.

LOADING LIQUID AND/OR POWDERED CHEMICAL WITH SUCTION LANCE

Note: Lance suction is dependent upon eductor pressure and flow. For best results, use highest pressure available up to 150 PSI maximum.

8. Insert lance body with o-ring into eductor until the o-ring is sealed.
9. Use the free end of the lance to pierce bag or container to vacuum powdered or liquid chemical.
10. Rinse lance. Place lance end into a clean container of water to rinse lance assembly.
11. Remove lance body from eductor and drain any remaining fluid into hopper.
12. Close knife valve (red handle). Turn inlet valve (yellow handle) off.

SHUTDOWN

1. Ensure that:
 - All valves are closed. Be sure to close knife valve first. (Close by pulling red handle out towards you.)
 - Chemical residue has been cleaned.
 - Hopper lid is closed and locked by turning cover clockwise.
2. Divert pump flow back to normal operation.

Symptom	Corrective Action
Low education rate	Check pump pressure and flow. Cleanload Eductor performance is based on flow and pressure to the system. Note requirements for high education rates. hoses outlet hoses are back to tank.
Plugged or clogged bottle rinse nozzle	Disassemble to by-pass nozzle from lance valve assembly and back flush until nozzle ports are clear of debris.
Plugged or clogged tank rinse nozzle	Disassemble to by-pass nozzle from NPV hose barb and back flush until nozzle ports are clear of debris. Remove screen and flush with water to clear any foreign material.
Filling leaks	Check for cracks in fitting. Replace fitting if necessary. Disassemble and add more joint seal in compound if leak occurs on threads.

15-620 CHEMICAL CLEAN LOAD® PARTS DRAWING

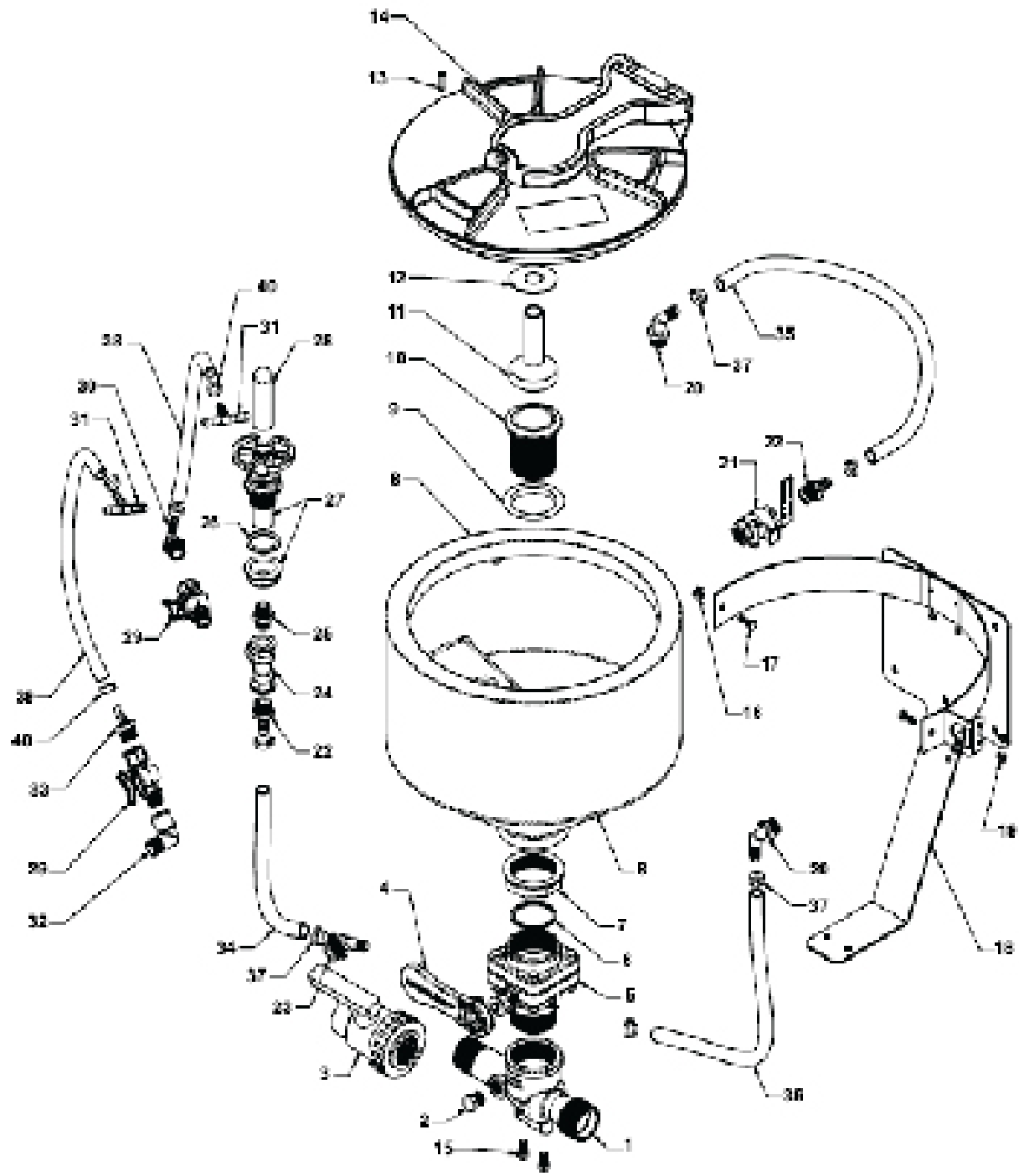

Accessories

15-620 CHEMICAL CLEAN LOAD® PARTS LIST

REF#	PART#	DESCRIPTION	QUANTITY
1	15-620-04	Cleanload Eductor	1
2		Plug, 1/2"	1
3	15-620-14	Ball Valve, 1 1/4" Single Union	1
4	15-620-13	Handle, Cleanload	1
5	15-620-12	Ball Valve	1
6	15-620-15	Gasket: 2"	1
7	15-620-16	Locking Ring, 2"	1
8	15-620-21	Tank, 5.8 gallon	1
9	15-620-17	Gasket: 2", Tapered	1
10	15-620-18	Drain Head, 2"	1
11	15-620-19	Tank Rinse	1
12		Slinger Ring	1
13		Screw, #6 x 1"	8
14	15-620-02	Tank Lid	1
15		Bolt, 5/16"-18 x 5/8	2
16		Nut, Flanged 1/4" - 20	2
17		Bolt, 1/4" - 20 x 3/4" SS	2
18	15-620-01	Frame, Back Mount	1
19		Screw, 10-24 x .375	2
20	15-620-11	Elbow 1/2"	2
21	15-620-10	Valve, SS Tank Rinse	1
22	15-620-09	HB, 1/2" MNPT x 1/2" HB	2
23	15-620-05	HB Tee, 1/2" MNPT to 1/2" HB	1
24		Tee, 1/2" FNPT	1
25		Nipple, 1/2"	1
26	15-620-20	Gasket, 1"	1
27		Valve, Bottle Rinse Base Assy.	1
28		Bottle Rinse Head	1
29		Valve, 1/2"	1
30		HB Elbow, 1/2" MNPT x 3/8" HB	1
31		HB Tee, 3/8"	1
32		1/2" Street Elbow	1
33		HB, 1/2" MNPT x 3/8" HB	1
34	15-620-07	Hose, Bottle Rinse, 1/2" EPDM	1
35	15-620-08	Hose, Tank Rinse, 1/2" EPDM	1
36	15-620-06	Hose, Valve Feeder, 1/2" EPDM	1
37		Hose Clamp, 1/2"	6
38		Hose Tank Rinse, 3/8" EPDM	1
39		Hose Tank Rinse, 3/8" EPDM	1
40		Hose Clamp, 3/8"	2

15-835 TANK RINSING SYSTEM

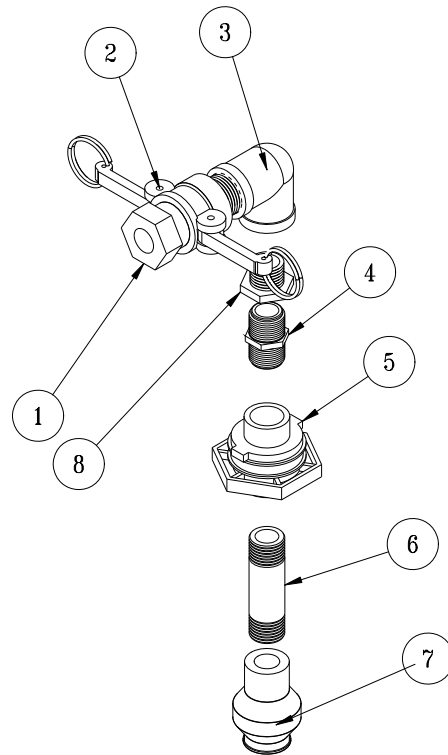

REF#	PART#	DESCRIPTION	QUANTITY
1	16-961	1" Adapter	1
2	16-962	1" Coupler	1
3	16-864	1" FTP Elbow	1
4	16-158	Close Nipple	1
5	16-150	Double Thread Fitting	1
6	16-172	4" Nipple	1
7	15-834	Tank Rinsing Nozzle	1
8	16-163	Reducer Bushing	1

Drill 1-3/4" hole 5" from outside edge of cover.

Install Tank Rinsing kit as shown, with the Double Thread Fitting (Ref 5) going into the cover.

Basket Must be removed During Use.

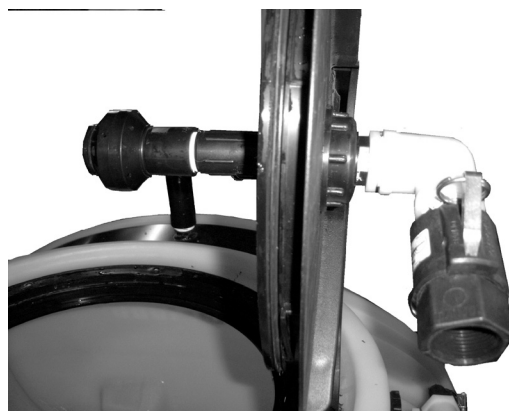

DECAL LIST

This is a list of decals located on the Spray Star 3180. Part number, description and location will help in reordering decals.

A	15-463 Decal, Spray Pump
B	16-228 Decal, Over the Road towing
C	25-277 Decal, Battery Warning
D	25-279 Decal, Safety Warning
E	25-286 Decal, Pinch Point
F	25-298 Decal, Warning Hot
G	25-321 Decal, Refuel w/ Diesel
H	25-356 Decal, Tire Pressure 20psi
I	25-371 Decal, Diesel
J	25-372 Decal, 4" Star
K	25-375 Decal, 94 dBA
L	25-380 Decal, Tire Pressure 30psi
M	27-077 Decal Smithco
N	27-093 Decal, Hydraulic Oil Level
O	30-016 Decal, Spray Star 3180
P	20-545 Decal, Dashboard
Q	30-019 Decal, Site Gauge
R	30-157 Decal, Control Panel
S	30-117 decal, Ultra Fuel
T	34-147 Decal, Smithco Logo
U	25-387 Decal, Agitation
V	14-803 Decal, Clean Agitation Line Strainer

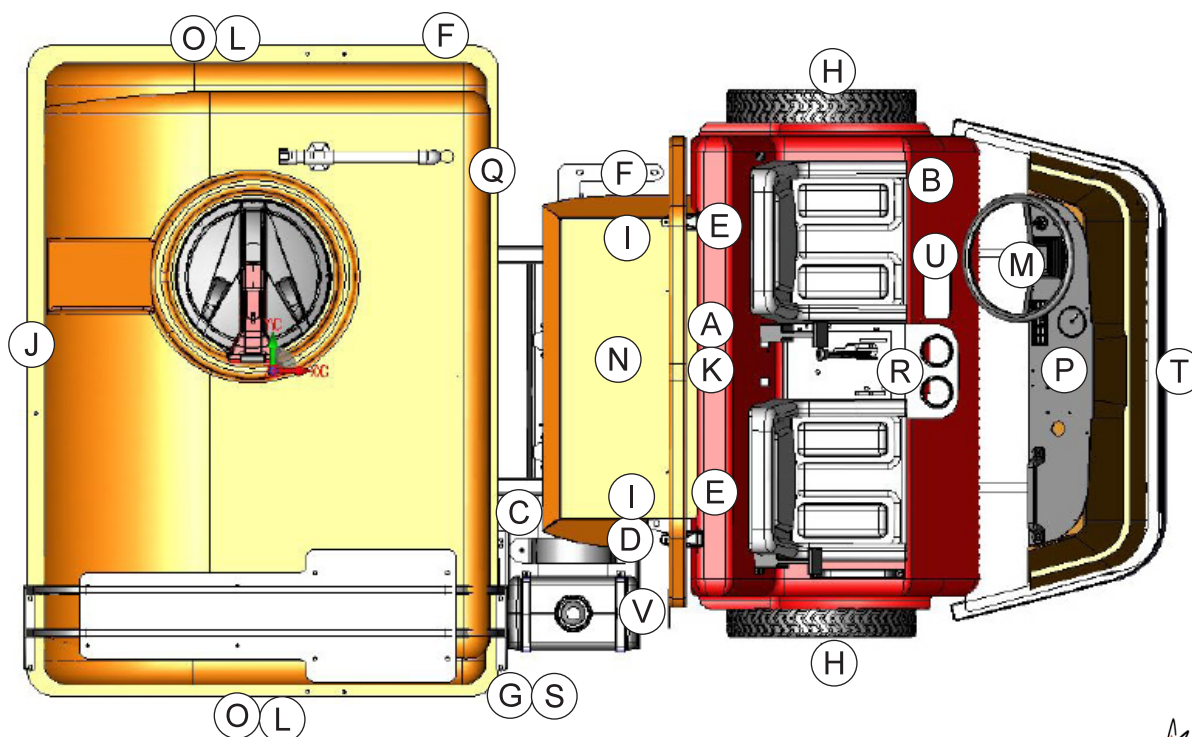

QUICK REFERENCE REPLACEMENT PARTS

REPLACEMENT FILTERS

72-146	Hydraulic Oil Filter Assembly
60-334	Replacement Element
30-042-05	Air Cleaner Cartridge
13-488	Key Switch
30-042-08	Fuel Filter Element
30-042-09	Engine Oil Filter
77-217	Exhaust Muffler Gasket

REPLACEMENT BELTS

30-137	Spray Pump Belt
30-042-11	Fan Belt

SEAL KITS

15-301	Power Steering Orbital Motor
15-301-01	Seal Kit
30-101	Wheel Motors
30-101-11	Seal Kit
30-102	Hydrostatic Pump
33-058-01	Seal Kit
76-197	Gear Pump
76-197-08	Seal Kit
15-839	Hydraulic Cylinder (steering)
14-531	Seal Kit

FLUIDS

Engine Oil	SAE 10W-40 API Service SJ or higher Motor Oil
Hydraulic Fluid	SAE 10W-40 API Service SJ or higher Motor Oil
Radiator	1.06 Gal 50/50 Antifreeze/water mixture

OTHER PARTS

16-953	Hinged Cover On Tank with Gasket
16-953-01	Gasket For Cover
16-169	Strainer Basket
15-818	#75 Fitting O-ring
15-817	#50 Fitting O-ring
20-663	Tank Lid Gasket
20-593	Circuit Breaker 50Amp