

Parts & Service

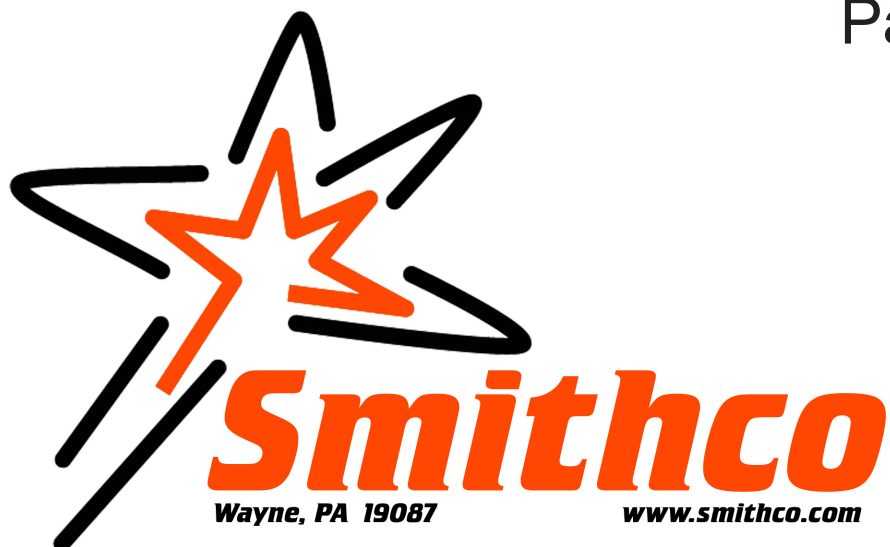

Big Vac Engine Drive
73-000-B
SN: 73096

March 2018

Product Support: **Hwy 55 & Poplar Ave; Cameron WI 54822**
1-800-891-9435 productsupport@smithco.com

CONTENTS

Introduction

Service

Diagrams

Parts

Accessories

Reference

Introduction	1-3
Introduction	1
Safe Practices	2
Specifications	3
Optional Equipment	3
Service	4-9
Maintenance	4-5
Service Chart	6-7
Overloading Debris Hopper and Vacuum Housing Wear	8
Adjustments	9
Diagrams	10-13
Wiring Drawings	10-11
Hydraulic Drawings	12-13
Parts	14-31
Big Vac Main	14-15
Control Panel	16-19
Gas and Oil Tank	20-21
Pulley and Pump Drawing	22-23
Vacuum and Blower Housing	24-25
Hopper	26-27
78-416 3 Bank Hydraulic Valve	28-29
72-048 Axle	30-31
Accessories	32-49
72-002 Rubber Finger Sweeper Head	32-35
72-005 Brush Reel Sweeper Head with 72-006 Brush Only	36-39
73-003 Standard Clevis Hitch	40-41
73-004 5th Wheel Hitch for Turf Truckster	42-43
73-005 5th Wheel Hitch for Cushman	44-45
73-006 Hand Held Vacuum Hose	46-49
73-007 3-Point Ball Hitch for Tractor	50
Reference	51-52
Decal List	51
Quick Reference Replacement Parts	52
Warranty	Inside Back Cover

Thank you for purchasing a **Smithco** product.

Read this manual and all other manuals pertaining to the Sand Star Zee carefully as they contain safety, operating, assembly and maintenance instructions. Failure to do so could result in personal injury or equipment damage.

Keep manuals in a safe place after operator and maintenance personnel have read them. Right and left sides are from the operator's seat, facing forward.

 **WARNING:**

Engine exhaust and some of its constituents are known to the State of California to cause cancer, birth defects, and other reproductive harm.

For more information visit www.P65Warning.ca.gov

WARNING

Failure to follow cautious operating practices can result in serious injury to the operator or other persons. The owner must understand these instructions, and must allow only trained persons who understand these instructions to operate this vehicle.

All **Smithco** machines have a Serial Number and Model Number. Both numbers are needed when ordering parts. Refer to engine manual for placement of engine serial number.

For product and accessory information, help finding a dealer, or to register your product please contact us at www.Smithco.com.

Information needed when ordering replacement parts:

1. Model Number of machine
2. Serial Number of machine
3. Name and Part Number of part
4. Quantity of parts

For easy access record your Serial and Model numbers here.

SMITHCO WAYNE, PENNSYLVANIA 19087 USA 610-688-4009 Fax 610-688-6069			
SERIAL NO. <input type="text"/>	kW/hp <input type="text"/>	DATE OF MFG. <input type="text"/>	
MODEL NO. <input type="text"/>	lb/kg Empty <input type="text"/>	lb/kg Full <input type="text"/>	

SMITHCO CUSTOMER SERVICE 1-800-891-9435

SAFE PRACTICES

1. It is your responsibility to read this manual and all publications associated with this machine (engine, accessories and attachments).
2. Never allow anyone to operate or service the machine or its attachments without proper training and instructions. Never allow minors to operate any equipment.
3. Learn the proper use of the machine, the location and purpose of all the controls and gauges before you operate the equipment. Working with unfamiliar equipment can lead to accidents.
4. Wear all the necessary Personal Protective Equipment (PPE) to protect our head, eyes, ears, hands and feet. **Ear and eye protection are required.** Operate the machine only in daylight or in good artificial light.
5. Inspect the area where the equipment will be used. Beware of overhead obstructions and underground obstacles. Stay alert for hidden hazards.
6. Never operate equipment that is not in perfect working order or without decals, guards, shields, or other protective devices in place.
7. Never disconnect or bypass any switch.
8. Carbon monoxide in the exhaust fumes can be fatal when inhaled, never operate a machine without proper ventilation.
9. Fuel is highly flammable, handle with care. When filling tank stop 1 inch(2.54 cm) from top. Leave room for expansion. **DO NOT OVERFILL.**
10. Never use your hands to search for oil leaks. Hydraulic fluid under pressure can penetrate the skin and cause serious injury.
11. This machine demands your attention. To prevent loss of control or tipping of the vehicle:
 - A. Use extra caution in backing up the vehicle. Ensure area is clear.
 - B. Do not stop or start suddenly on any slope.
 - C. Reduce speed on slopes and in sharp turns. Use caution when changing directions on slopes.
 - D. Stay alert for holes in the terrain and other hidden hazards.
 - E. Operate equipment up and down slopes, never across the face.
12. Before leaving operator's position for any reason:
 - A. Disengage all drives.
 - B. Lower all attachments to the ground.
 - C. Shut engine off and remove the ignition key.
13. Keep hands, feet and clothing away from moving parts. Wait for all movement to stop before you clean, adjust or service the machine.
14. The rubber fingers, sweeper and vacuum pick up and propel debris and small objects in machines path during operation. Keep the area of operation clear of all bystanders.
15. Never carry passengers.
16. Use parts and materials supplied by **Smithco** only. Do not modify any function or part.
17. Avoid sharp turns. Watch the tires of the tractor while turning to make sure they do not contact the tongue of the Big Vac.
18. Shut down power source before attempting to unclog any part of the machine.
19. If reel deck and/or blower began to vibrate abnormally, immediately shut off power and determine the cause.
20. Always drive at a safe towing speed relative to conditions and ensure that your speed is low enough for an emergency stop to be safe and secure. Smithco recommends a maximum speed of 8mph (12 kph).

These machines are intended for professional maintenance on golf courses, sports turf, and any other area maintained turf and related trails, paths and lots. No guaranty as to the suitability for any task is expressed or implied.

SPECIFICATIONS FOR BIG VAC ENGINE DRIVE

WEIGHTS AND DIMENSIONS

Length	180" (458 cm)
Width	84" (214 cm)
Height	87" (221 cm)
Weight	2950 lb (1338 kg)

SOUND LEVEL

At ear level	98 dBA
At 30 ft (9.14 m)	92.5 dBA

ENGINE

Make	Briggs & Stratton
Model#	543477
Type/Spec	0175J1
Horsepower	31 Hp (23 kW)
Fuel	Unleaded 87 Octane Gasoline Minimum
Cooling System	Air Cooled
Lubrication System	Full Pressure
Alternator	24 Amp

TIRES & WHEELS

Two 26.5 - 1400 x 12 NHS (18 psi (1.3 bar)) Fairway Type Turf Tires
Castor: 13 x 5 x 6 (20 psi (1.4 bar))

BATTERY (optional)

	Automotive type 45 - 12 volt
BCI Group	Size 45
Cold Cranking Amps	480 minimum
Ground Terminal Polarity	Negative (-)
Maximum Length	9" (23 cm)
Maximum Width	5.38" (14 cm)
Maximum Height	9" (23 cm)

FLUID CAPACITY

Crankcase Oil	See Engine Manual
Fuel	6 gallon (22.7 liters)
Hydraulic Fluid	3.2 gallon (12.2 liters)
Grade of Hydraulic Fluid	SAE 10W-40 API Service SJ or higher Motor Oil

OPTIONAL EQUIPMENT

72-002 Rubber Finger Sweeper Head	73-003 Standard Clevis Hitch
72-005 Nylon Brush Head	73-004 5th Wheel Hitch for Turf Truckster w/ Electric brakes
72-006 Replacement Brush Reel	73-005 5th Wheel Hitch
22-073 Battery	73-006 Vacuum Hose Hand Held
	73-007 3-Point Hitch for 35HP (minimum) Tractor

MAINTENANCE

⚠ CAUTION

Before servicing or making adjustments to machine, stop engine on tow vehicle and remove key from ignition.

⚠ IMPORTANT

Use all procedures and parts prescribed by the manufacturer's. Read the engine manual before operation.

LUBRICATION

Use No. 2 General Purpose Lithium Base Grease and lubricate **DAILY**. The Big Vac has 13 grease fittings. All bearings are sealed bearings. When inserting grease, be careful not to ruin the seal, if this happens, replace the bearing at once. Be sure to wipe grease fitting clean before injecting grease. Give only one or two pumps of grease at each lubrication.

REF# LOCATION

- 1 One on all four castor wheels.
- 2 Two on the fan shaft.
- 3 One on each mounted bearing for reel shaft.
- 4 One on all four castor wheel mount brackets.
- 5 One on the jack stand.

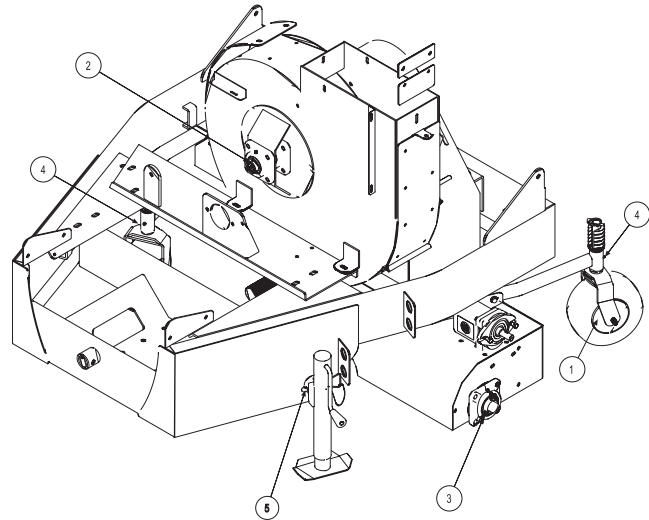

HYDRAULIC OIL

1. Use SAE 10W-40 API Service SJ or higher motor oil.
2. For proper warranty, change oil every 500 hours or annually, whichever is first and change the filter after the first 50 hours, then every 250 hours thereafter.
3. Inspect hydraulic lines for damage or leaks. Never use hands to inspect leaks.
4. Check hydraulic fluid level in tank. Look at the sight gauge on the front left side of the tank. The oil level should be at 90°C (194°F). If level is low, add SAE 10W-40 API Service SJ or higher motor oil.
5. After changing oil and/or filter, operate the machine for a few minutes. Check oil level and for leaks.
6. Always use caution when filling hydraulic oil tank or checking level to keep system free of contaminants. Check and service more frequently when operating in extremely cold, hot or dusty conditions.
7. If natural color of fluid is now black or smells burnt, it is possible that an overheating problem exists.
8. If fluid becomes milky, water contamination may be a problem.
9. If either of the above conditions happen, change oil and filter immediately after fluid is cool and find cause. Take fluid level readings when system is cold.
10. In extreme temperatures you can use straight weight oil. We recommend SAE 30W API Service SJ or higher when hot (above 90°F (33°C)) and SAE 10W API Service SJ or higher when cold (below 32°F (0°C)) ambient temperature. Use either motor oil or hydraulic oil, but do not mix.
11. Oil being added to the system must be the same as what is already in the tank. Mark tank fill area as to which type you put in.

TIRE PRESSURE

Caution must be used when inflating a low tire to recommended pressure. Over inflating can cause tires to explode. Tires on the machine should be 18 psi (1.3 bar), castor wheels should be 20 psi (1.4 bar). Improper inflation will reduce tire life considerably.

ENGINE OIL

Change and add oil according to charts below. Do not overfill. Use a high quality detergent oil. For Briggs engine use oil classified "For Service SJ or higher" SAE 30 oil. Use no special additives with recommended oils. Do not mix oil with gasoline.

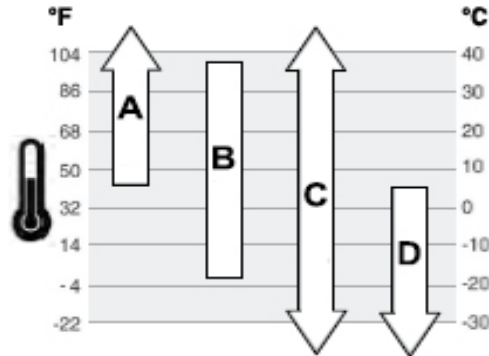

A	SAE 30 - Below 40 °F (4 °C) the use of SAE 30 will result in hard starting.
B	10W-30 - Above 80 °F (27 °C) the use of 10W-30 may cause increased oil consumption. Check oil level more frequently.
C	Synthetic 5W-30
D	5W-30

WHEEL MOUNTING PROCEDURE

1. Turn machine off and remove key.
2. Be sure unit is on a level surface. Unhitch from tow vehicle if possible.
3. Block the opposite wheel then the one you are working on.
4. Loosen nuts slightly on wheel to be removed.
5. Jack up machine being careful not to damage underside of machine.
6. Remove nuts, remove wheel.
7. Place new wheel on hub lining up Hex Bolt holes.
8. Torque nuts to 64-74 ft/lb (87-100 Nm) using a cross pattern. Torque again after first 10 hours and every 200 hours thereafter.
9. Lower machine to ground and remove blocks and jack.

HOPPER LIFT SAFETY

The Hopper Lift Safety is used to support the ram on the hopper bottom in the extended position so you may service or repair the machine under the hopper. When not in use the Hopper Lift Safety can be stored on the hopper bed frame.

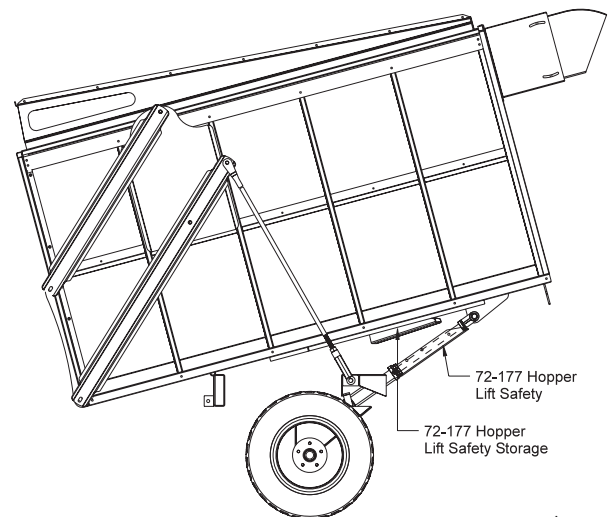

SERVICE CHART

⚠ CAUTION

Before servicing or making adjustments to the machine, stop engine, set park break, block wheels and remove key from ignition.

⚠ IMPORTANT

Follow all procedures and **ONLY** use parts prescribed by the manufacturer. Read the engine manual before maintenance.

The suggested maintenance checklist is not offered as a replacement for the manufacturer's engine manual but as a supplement. You must adhere to the guidelines established by the manufacturer for warranty coverage. In adverse conditions such as dirt, mud or extreme temperatures, maintenance should be more frequent.

Maintenance Service Interval	Maintenance Procedure
After the first 5 operating hours	Torque the wheel lug nuts. (64-74 ft/lb (87-100 Nm))
	Change the engine oil filter.
Before each use daily	Check the engine oil level.
	Clean area around muffler and controls.
	Check the tire pressure.
	Inspect and clean the machine.
Every 50 hours	Clean or change air filter.1&2
	Clean pre-cleaner.1
	Change engine oil and filter.
Every 100 hours	Replace spark plug.
	Lubricate machine.
	Clean or change remote air cleaner.
	Check the battery fluid level and cable connections..
	Change engine oil and filter
	Check belt tension .
Every 250 hours	Check Idle Speed.
	Clean battery terminals.
	Torque the wheel lug nuts. (64-74 ft/lb (87-100 Nm))
Every 400 hours or yearly	Change fuel filter.
	Clean oil cooler fins.1
	Replace air filter2
	Replace fuel filter
	Clean air cooling system.1
	Check safety filter in remote air cleaner.
1 In dusty conditions or when airborne debris is present, clean more often.	
2 Every third air filter change, replace the inner safety filter.	

SERVICE CHART

Duplicate this page for routine us

Maintenance Check Item	For the week of:						
	Mon	Tues.	Wed.	Thurs.	Fri.	Sat.	Sun.
Check the fuel level							
Check the engine oil level.							
Check the condition of the air filter							
Clean the engine cooling fins.							
Check for unusual engine noises							
Check the tire pressure (18 psi)							
Check the Instrumentation							
Inspect electrical system for frayed wires							
Change oil filter.							
Change oil.							
Lubricate Machine and Booms							
Ensure all warning decals are intact.							
Areas of Concern							
Inspection Performed by:							
Item	Date		Information				

Service

OVERLOADING DEBRIS HOPPER AND VACUUM HOUSING WEAR

SMITHCO SWEEPER-VACS ARE DESIGNED TO CARRY THE FOLLOWING MAXIMUM LOADS:

Model 73-000 Big Vac V72E	1500 lbs. (608 kg)
Model 72-000 Big Vac V72	1500 lbs. (608 kg)

PLEASE NOTE THE FOLLOWING:

1. Loads heavier than that will damage the unit.
2. Such damage is not covered by warranty.
3. Overloading is particularly easy when collecting aerifier cores.
4. The hoppers on the Big Vac are large in order to hold 7 and 4 cubic yards respectively, of thatch, grass clippings, leaves and trash.
5. They will not hold 7 or 4 cubic yards of aerifier cores.
6. The maximum depth (in the debris hopper) of aerifier cores is:

Model 73-000 Big Vac V72E	12 in. (30 cm)
Model 72-000 Big Vac	12 in. (30 cm)

Overloading will cause damage that is not covered by the warranty.

VACUUM HOUSING WEAR

The Big Vac are fitted with a wear resistant liner in the vacuum housing. This will provide additional housing life. Be sure the following points are explained to the user:

1. The vacuum housing and impeller must be cleaned each time the unit is used so the housing liner is inspected daily. Only Smithco Sweeper-Vacs provide a clean out/inspection port for easy inspection and cleaning.
2. When bare steel is visible at any point in the housing lining, the lining must be replaced. It is expected the liner will wear and be replaced. It is a vast improvement over competitive units with no liners.
3. Replacement of the liner or the vacuum housing due to wear is normal and is not covered by warranty.
4. Collection of aerifier cores causes extreme wear on the liner (and if unchecked, on the housing).
5. Caution users that, while Smithco Sweeper-Vacs do an excellent job collecting cores, the lining (and the housing) will wear quickly in such use.

RUBBERIZED BOOT

The rubberized boot between main unit and sweeper head is subject to wear and damage from debris. Unless defective, replacement of this boot is not covered by warranty.

STORAGE

1. Before storing clean machine thoroughly.
2. Check Hex Bolts and nuts, tighten as necessary.
3. Make all repairs that are needed and remove any debris.
4. Store in a clean and dry area.

ADJUSTMENTS

ADJUSTMENT OF BELT TENSIONER

There are four maximum belt tensioners on the Big Vac. Two control the tension on the belts on the blower housing, one each on the finger reel and the thatcher reel. The proper tension of the idler should be 12 to 15 as per the gauge (A) on the side of the tightener. Over tightening the belt will shorten the life of the belt and the machine may not perform to the best of its ability. To adjust belt tensioner, loosen Hex Bolt holding tensioner. Bring idler pulley tight to belts and turn tensioner into belts to 15°. Tighten holder Hex Bolt.

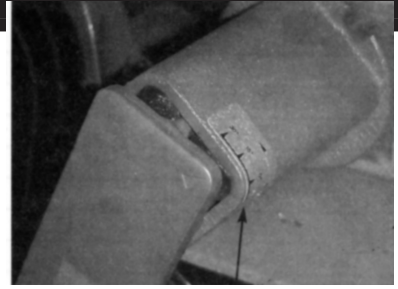

CONTROL PANEL ADJUSTMENT ARM

On the right hand side of machine is the adjustment lock arm, by lifting up you can adjust the control panel by moving it forward or rearward. Make certain that the lock arm is locked back in place after adjustment. For up and down adjustment loosen the four adjustment Hex Bolts place the control panel to where you want it and tighten the four Hex Bolts.

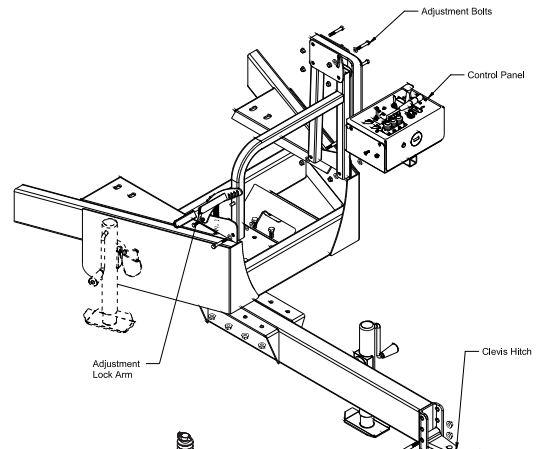

HITCH OPTIONS

You may use the clevis hitch that is shipped with your machine or a 2⁵/₁₆ ball hitch that is an optional accessory. Both mount in the same location with three different Hex Bolt hole options.

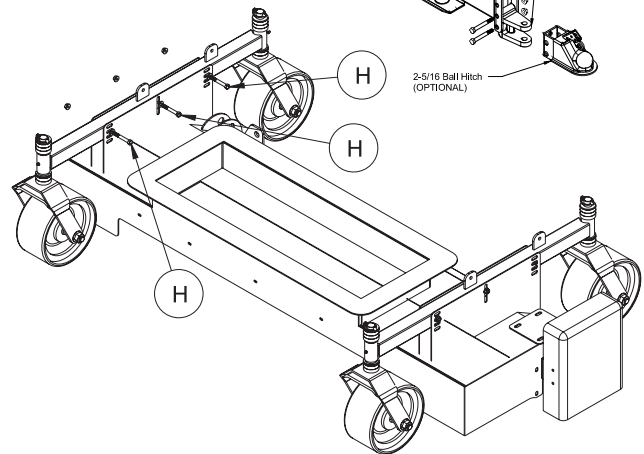

SINGLE REEL HOUSING

Normal setting is two slots down (H) both front and rear (both sides).

CASTOR WHEELS

Install castor wheels onto the brush/finger head assembly. You may put the machine bushings and spacers (A) on in any combination to get desired height. You should leave one machine bushing on the very bottom and one on the very top next to the lock pin. Check the tire pressure on Castor Wheels they should be 20 psi (1.4 bar).

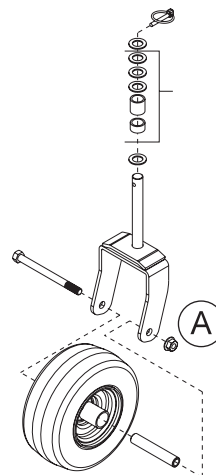

WIRING DRAWING

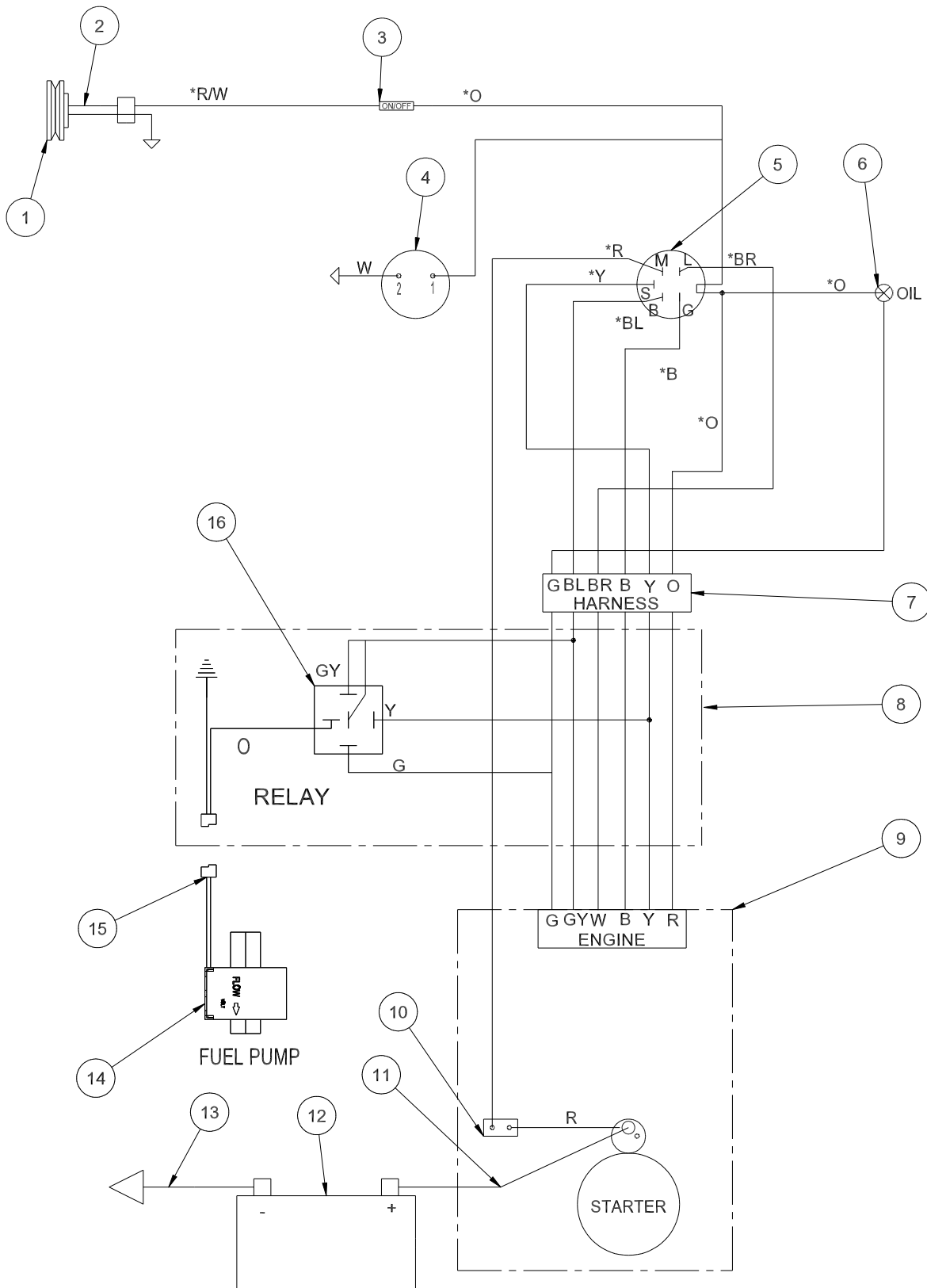

Diagrams

WIRING PARTS LIST

REF#	PART#	DESCRIPTION	QUANTITY
1	78-368	Electric Clutch	1
2	17-271	Pigtail Harness for Electric Clutch	1
3	15-314	Toggle Switch	1
	15-472	Switch Boot	1
4	12-804	Hour Meter	1
5	13-488	Ignition Switch	1
6	50-359	Oil Light	1
	8874	Female Bullet Connector	1
	8875	Male Bullet Connector	1
	8963	Heat Shrink	2
7	78-442	Main Wire Harness (includes all wire colors with *)	1
8	76-633	Fuel Pump Wire Harness	1
9		Plug on Engine	1
10	8975	30 Amp Circuit Breaker	1
	8977	Circuit Breaker Boot	1
11	78-325	Red Battery Cable with Boot	1
12	22-073	Battery	1
13	22-054	Battery Cable Black	1
14	76-471	Electric Fuel Pump	1
15	15-814	2-Contact Tower	1
	9017	Weather Pack Terminal	2
	9018	Seal	2
16	30-042-06	Relay	1
	78-442	Wire Harness (includes all wire colors with *)	
	76-633	Electric Fuel Pump Wire Harness	

HYDRAULIC DRAWING

Diagrams

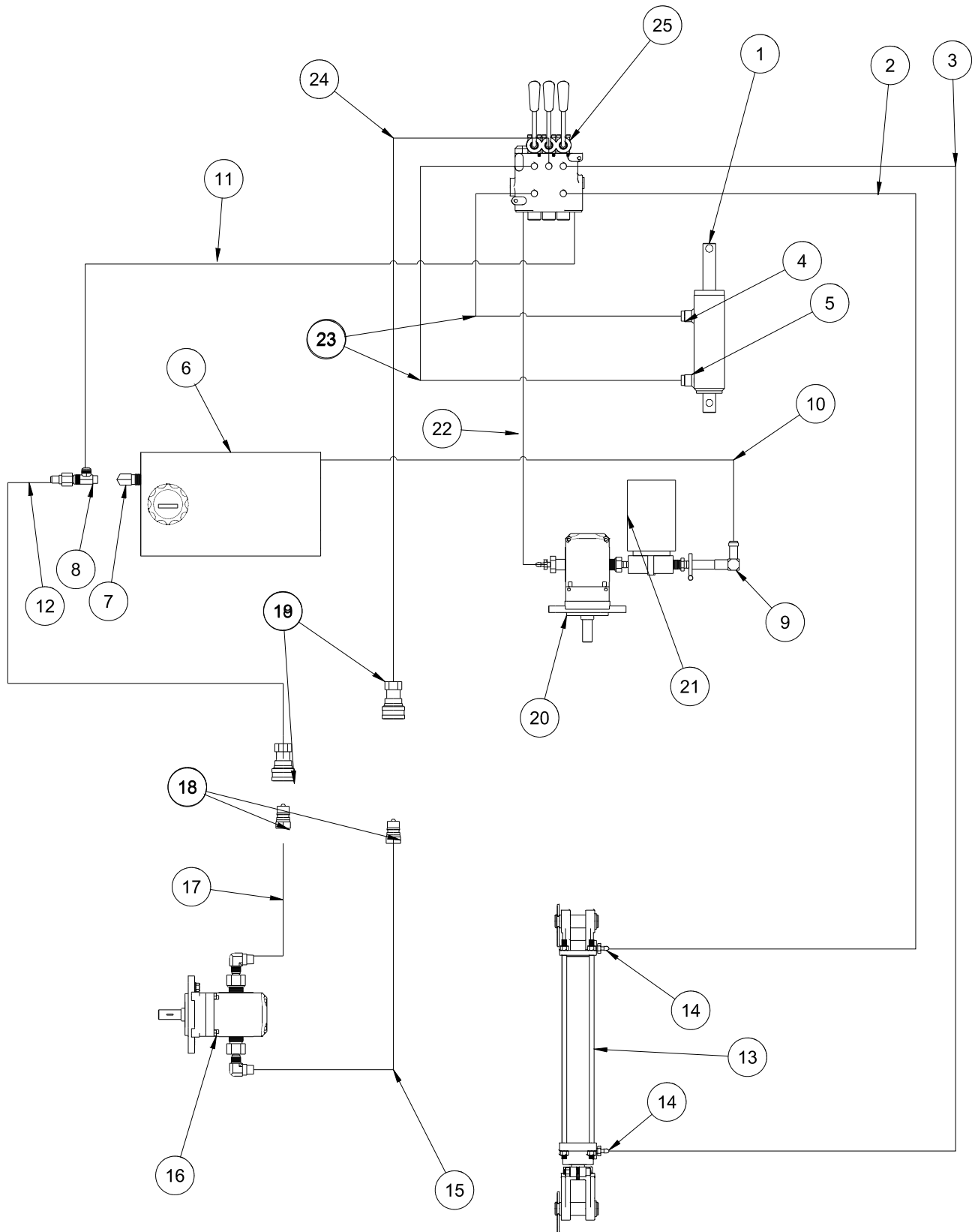

HYDRAULIC PARTS LIST

REF#	PART#	DESCRIPTION	QUANTITY
1	10-187	Hydraulic Cylinder	1
	14-273	Seal Kit	
	HCP-12-200	Clevis Pin, 1/2 x 2	2
	HP-18-100	Cotter Pin, 1/8 x 1	2
2	73-012	Hydraulic Hose, 186"	1
3	73-011	Hydraulic Hose, 206"	1
4	18-169	Adapter, 3/8 SAE	1
5	78-365	Adapter with Orifice	1
6	60-473	Oil Tank	1
	13-747	Filler Breather	1
	13-586-03	Neck	1
7	17-019	Male Elbow	1
8	18-190	Tee	1
9	23-142	Connector	1
10	8917-9	5/8 Suction Hose, 9"	1
	18-040	Hose Clamp	2
11	73-015	Hydraulic Hose, 90"	1
12	73-017	Hydraulic Hose, 53"	1
13	72-040	Hydraulic Cylinder	1
	72-040-01	Seal Kit	
14	23-184	Male Connector	2
15	72-075	Hydraulic Hose	1
16*	72-199	Hydraulic Motor	1
17	72-074	Hydraulic Hose	1
18	72-043	Quick Coupler 1/2" Male End	2
19	72-046	Quick Coupler 1/2" Female End	2
20*	78-413	Hydraulic Pump	1
21	23-006	Oil Filter	1
	23-031	Replacement Filter	
22	73-016	Hydraulic Hose, 90"	1
23	73-013	Hydraulic Hose, 118"	2
24	73-014	Hydraulic Hose, 94"	1
25	78-416	Hydraulic 3-Bank Bank Valve	1

* No other parts are replaceable for hydraulic motor or pump.

HYDRAULIC PRESSURES	Front	Rear
Pump Displacement	.90 in ³ /rev	.40 in ³ /rev
Pump Input Speed (up to)	4000 rpm	4000 rpm
Max. Operating Pressure	3600 psi	3600 psi
Max. Inlet Vacuum	10 in. Hg	10 in. Hg
Max. Case Pressure	80 psi	80 psi

BIG VAC MAIN DRAWING

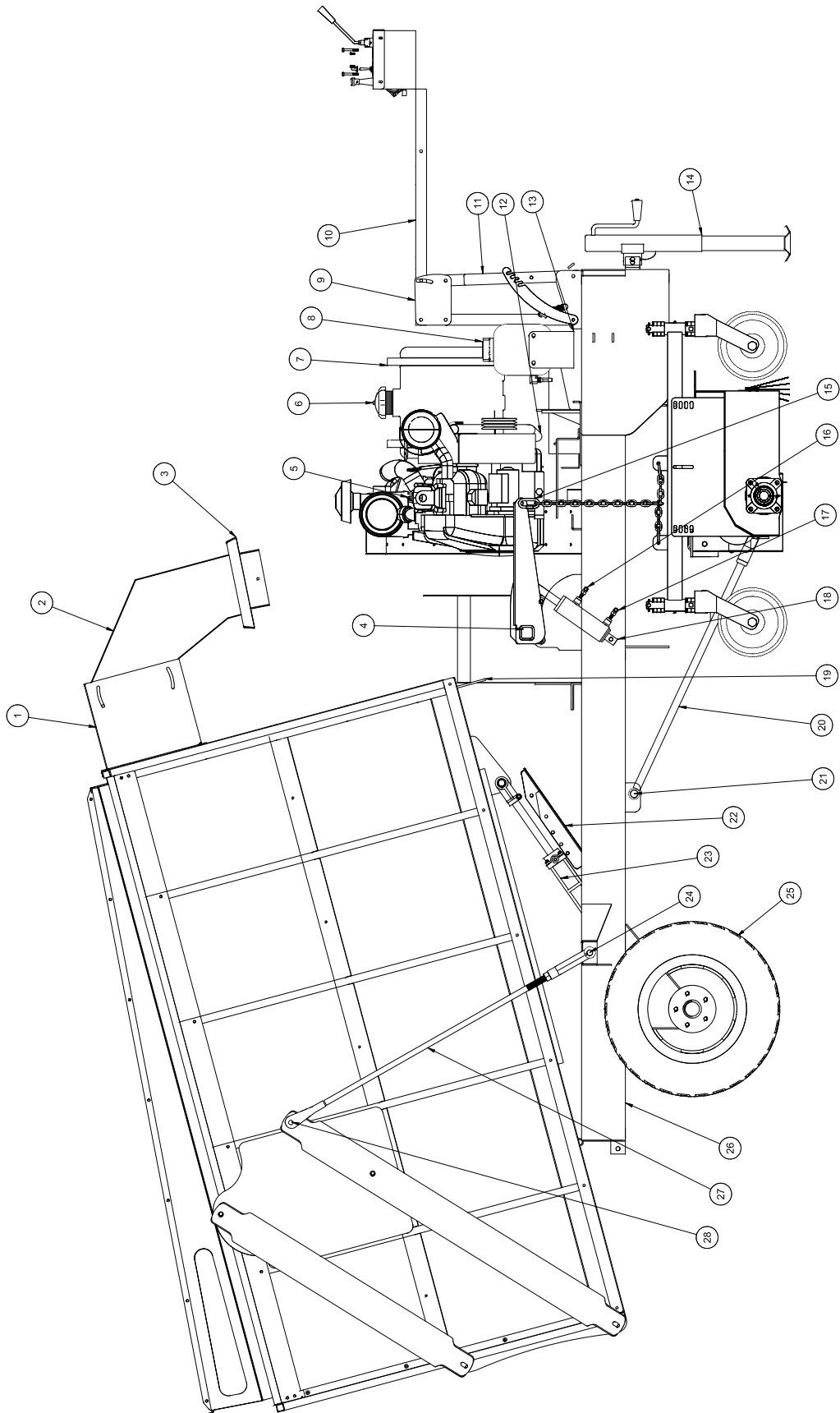

Parts

BIG VAC MAIN PARTS LIST

REF#	PART#	DESCRIPTION	QUANTITY
1	72-110	Hopper Chute	1
2	73-026	Debris Chute	1
	8980-60	Trim Seal 60"	1
3	73-024	Chute Flange	1
4	73-061	Reel Lift Cross Bar	1
	HB-12-13-125	Hex Bolt, 1/2 - 13 x 1 1/4	2
	HNTL-12-13	Nylon Lock Nut, 1/2 - 13	2
5	76-484	31HP Vanguard Engine	1
6	73-049	Fuel Tank	1
	73-050	Fuel Tank Cap	1
7	73-051	Gas Tank Strap	2
8	60-473	Oil Tank	1
	13-747	Filler Breather	1
	13-586-03	Neck	1
9	72-119	Control Panel Adjustment	2
10	73-040	Control Panel Mount	1
11	72-121	Control Panel Leg	1
12	73-055	Belt Cover	1
	73-056	Belt Cover Brace	1
13	73-059	Oil Tank Mount	1
14	78-240	Trailer Jack	1
15	HCP-12-200	Clevis Pin, 1/2 x 2	2
	HP-18-100	Cotter Pin, 1/8 x 1	2
16	18-169	Adapter	1
17	78-365	Adapter with Orifice	1
18	10-187	Hydraulic Cylinder	1
	14-273	Seal Kit	1
	HCP-12-200	Clevis Pin, 1/2 x 2	2
	HP-18-100	Cotter Pin, 1/8 x 1	2
19	72-183	Guide Bumpers	2
20	72-103	Reel Lift Rod	2
21	HCP-100-200	Clevis Pin, 1 x 2	4
	HHP-18-100	Bridge Pin, 1/8 x 1	4
22	72-177	Hopper Lift Safety	1
	HB-38-16-250	Hex Bolt, 3/8 - 16 x 2 1/2	2
	HNW-38-16	Wing Nut, 3/8 - 16	2
23	72-040	Hydraulic Cylinder	1
	72-040-02	Pin with Clips (part of 72-040)	2
	72-040-01	Seal Kit	1
	23-184	Male Connector	2
24	HMB-34-10	Machine Bushing, 3/4 x 10GA	6
	HP-18-100	Cotter Pin, 1/8 x 1	2
25	72-042	Tire and Wheel	2
	33-072-01	Tire, W26.5 x 14.00 - 12 4 Ply	2
	72-042-02	Wheel	2
26	72-080	Main Frame	1
27	72-099	Tailgate Lift Rod	2
28	HCP-12-175	Clevis Pin, 1/2 x 1 3/4	2
	HP-18-100	Cotter Pin, 1/8 x 1	2
NS	72-140	Boot (Connects vacuum hosing to reel deck)	1
NS	72-148	Sway Bar	2
NS	72-140	Yoke End	1

CONTROL PANEL DRAWING

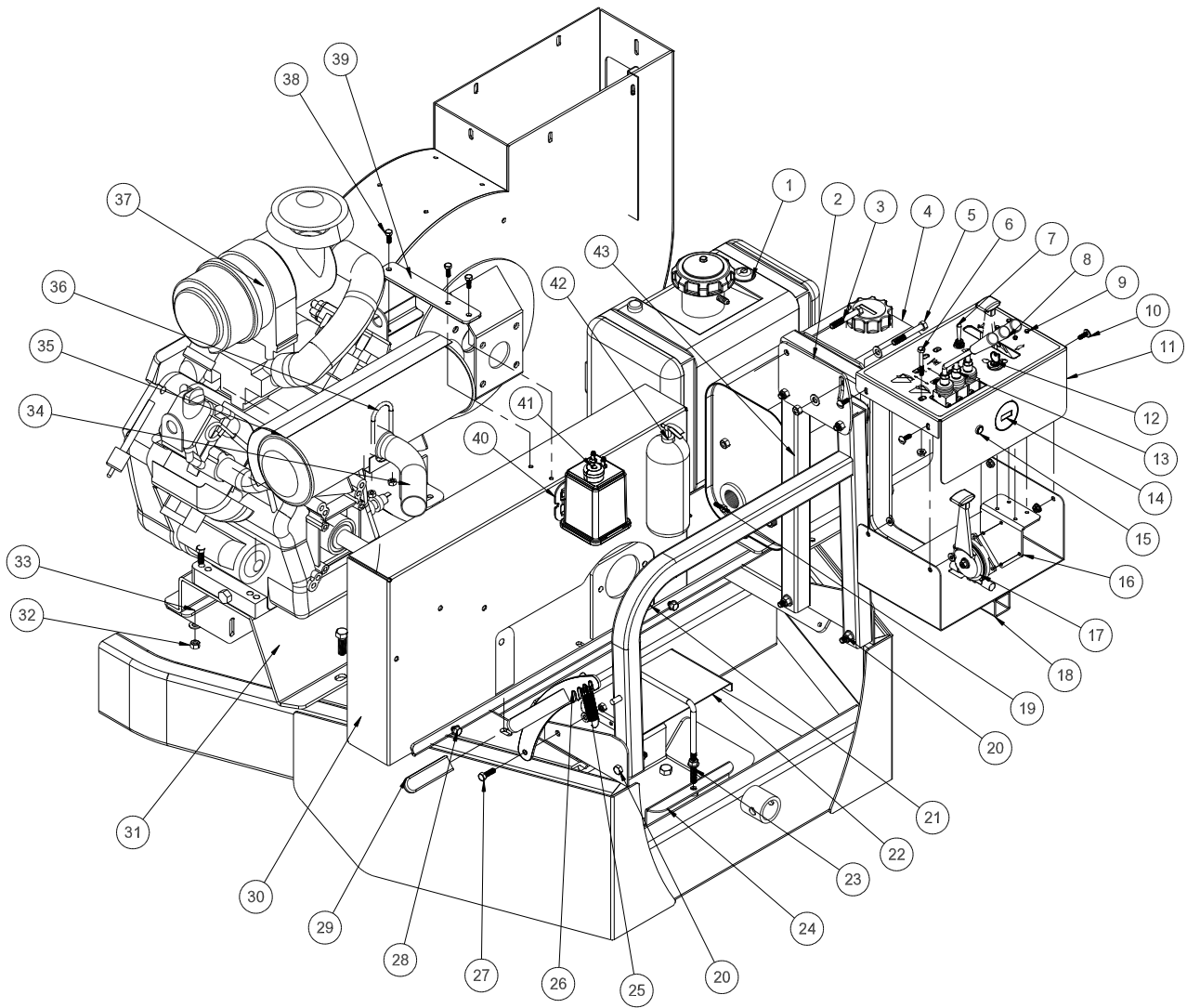

PARTS

CONTROL PANEL PARTS LIST

REF#	PART#	DESCRIPTION	QUANTITY
1	15-838	6 Gal. CARB Gas Tank (includes all * items)	1
2	72-119	Control Panel Adjustment Bracket	2
3	HB-38-16-250	Hex Bolt, $\frac{3}{8}$ - 16 x $2\frac{1}{2}$	3
	HNTL-38-16	Nylon Lock Nut, $\frac{3}{8}$ - 16	3
4	60-473	Oil Tank	1
5	HB-38-16-275	Hex Bolt, $\frac{3}{8}$ - 16 x $2\frac{3}{4}$	1
	HW-38	Flat Washer, $\frac{3}{8}$	2
	HNTL-38-16	Nylon Lock Nut, $\frac{3}{8}$ - 16	1
6	HB-14-20-200	Hex Bolt, $\frac{1}{4}$ - 20 x 2	2
	HNFL-14-20	Flange Whiz-loc Nut, $\frac{1}{4}$ - 20	2
7	15-472	Switch Boot	1
	15-314	Toggle Switch	1
8	78-418	Bent Handle	2
	78-417	Straight Handle	1
9	HSM 8-32-050	Machine Screw, #8-32 x $\frac{1}{2}$	4
	HWL-8	Lock Washer, #8	4
	HNFL-8-32	Flange Whiz-loc Nut, #8-32	4
10	HSTP-14-20-075	Phillips Truss Head Hex Bolt, $\frac{1}{4}$ - 20 x $\frac{3}{4}$	4
	HNFL-14-20	Flange Whiz-loc Nut, $\frac{1}{4}$ - 20	4
11	78-446	Control Panel	1
	78-217	Decal, Control Panel	1
	78-438	Decal, Dumping Debris	1
12	13-488	Ignition Switch	1
13	78-416	3-Bank Hydraulic Valve	1
14	12-804	Hour Meter	1
15	78-340	Oil Light	1
16	34-159	Throttle Mounting Bracket	1
17	78-337	Throttle Cable	1
18	73-040	Control Panel Mount	1
19	HB-38-16-250	Hex Bolt, $\frac{3}{8}$ - 16 x $2\frac{1}{2}$	3
	HW-38	Flat Washer, $\frac{3}{8}$	6
	HNTL-38-16	Nylon Lock Nut, $\frac{3}{8}$ - 16	3
20	HB-38-16-250	Hex Bolt, $\frac{3}{8}$ - 16 x $2\frac{1}{2}$	3
	HW-38	Flat Washer, $\frac{3}{8}$	6
	HNTL-38-16	Nylon Lock Nut, $\frac{3}{8}$ - 16	3
21	72-121	Control Panel Leg	1
22	72-206	Battery Cover	1
23	73-053	Battery Hold-down	1
24	73-018	Battery Box	1
	72-206	Battery Box Cover (not illustrated)	1
25	60-323	Spring	1
26	72-093	Adjustment Lock Arm	1
27	HB-516-18-100	Hex Bolt, $\frac{5}{16}$ - 18 x 1	1
	HW-516	Flat Washer, $\frac{5}{16}$	2
	HNTL-516-18	Nylon Lock Nut, $\frac{5}{16}$ - 18	1

(Continued on Next Page)

CONTROL PANEL DRAWING

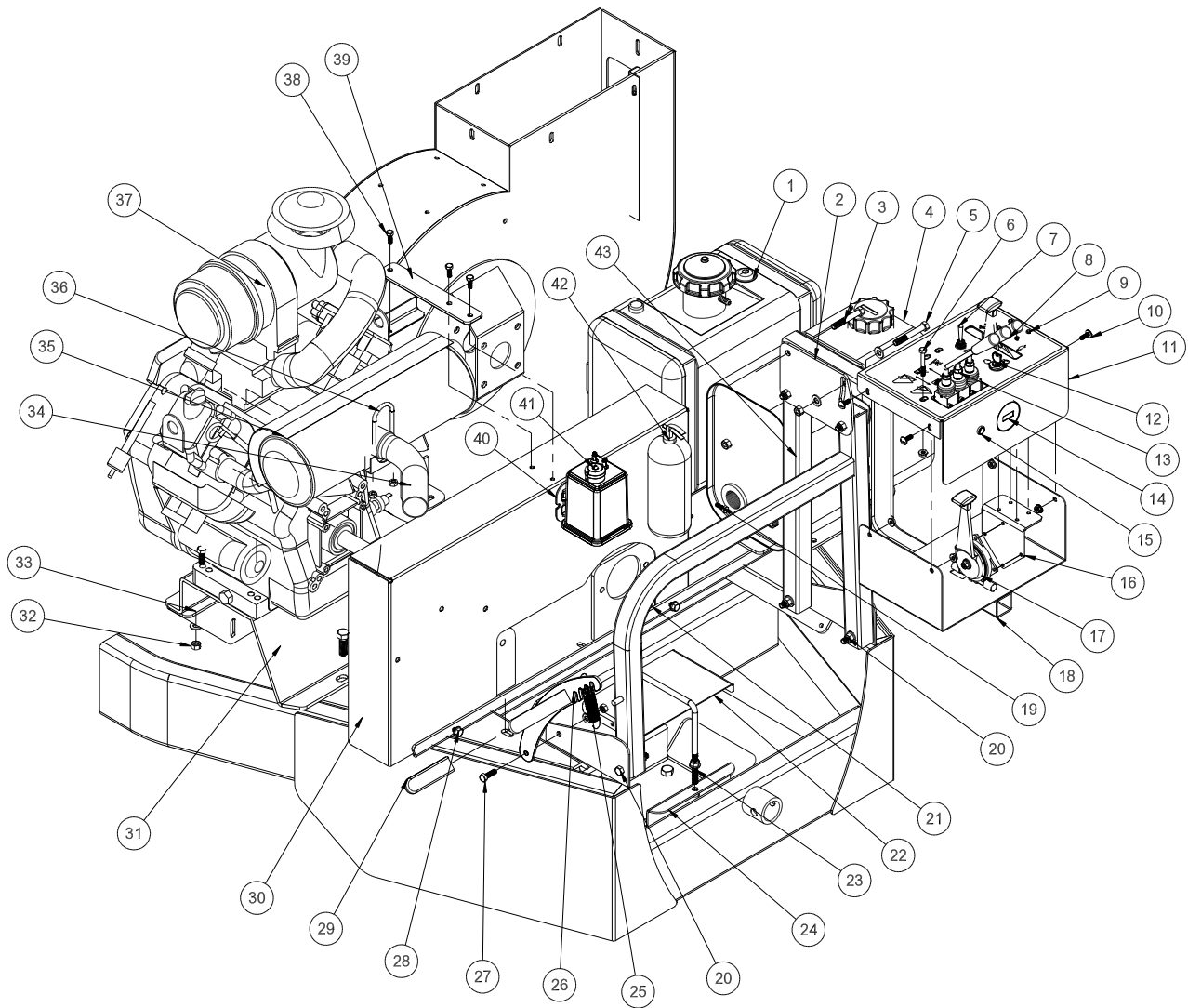

PARTS

CONTROL PANEL PARTS LIST

REF#	PART#	DESCRIPTION	QUANTITY
28	HBFL-516-18-075	Flange Whiz-loc Bolt, $\frac{5}{16}$ - 18 x $\frac{3}{4}$	2
	HNFL-516-18	Flange Whiz-loc Nut, $\frac{5}{16}$ -18	2
29	15-020	Grip	1
30	73-055	Belt Guard	1
31	73-058	Engine Plate	1
	HB-12-13-150	Hex Bolt, $\frac{1}{2}$ - 13 x $1\frac{1}{2}$	2
	HNTL-12-13	Nylon Lock Nut, $\frac{1}{2}$ - 13	2
32	HB-38-16-250	Hex Bolt, $\frac{3}{8}$ - 16 x 1	2
	HNTL-38-16	Nylon Lock Nut, $\frac{3}{8}$ - 16	2
33	73-020	Engine Support	1
34	73-062	Tail Pipe	1
35	76-447	Muffler	1
	73-060	Muffler Guard	1
36	50-394	Muffler Clamp	1
37	76-484	31hp Vanguard Engine	1
	76-452	Fan Screen	1
	76-453	Hardware Kit	1
38	HB-14-20-075	Hex Bolt, $\frac{1}{4}$ - 20 x $\frac{3}{4}$	3
	HNTL-14-20	Nylon Lock Nut, $\frac{1}{4}$ - 20	3
39	73-056	Belt Cover Brace	1
40	8-688	Canister Mount	1
41	8-689	Carbon Canister	1
	8800-70	Fuel Line 70" (canister to air cleaner)	1
	18-186	Clamp	2
42	76-354	Fire Extinguisher	1
43	72-120	Adjustment Leg	1

Cyclonic air cleaner 76-395-04

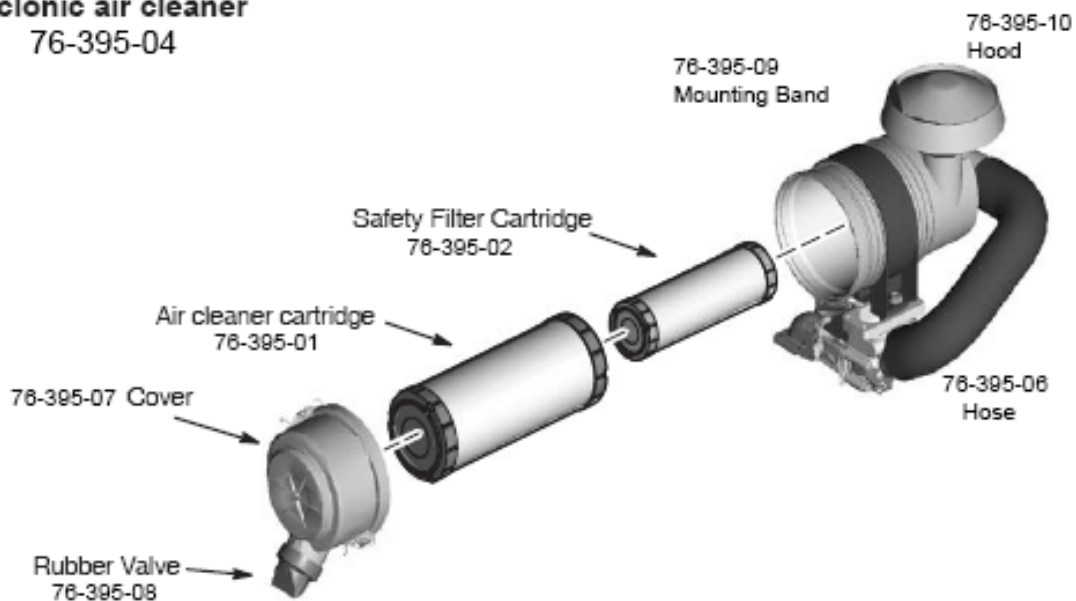

GAS & OIL TANK DRAWING

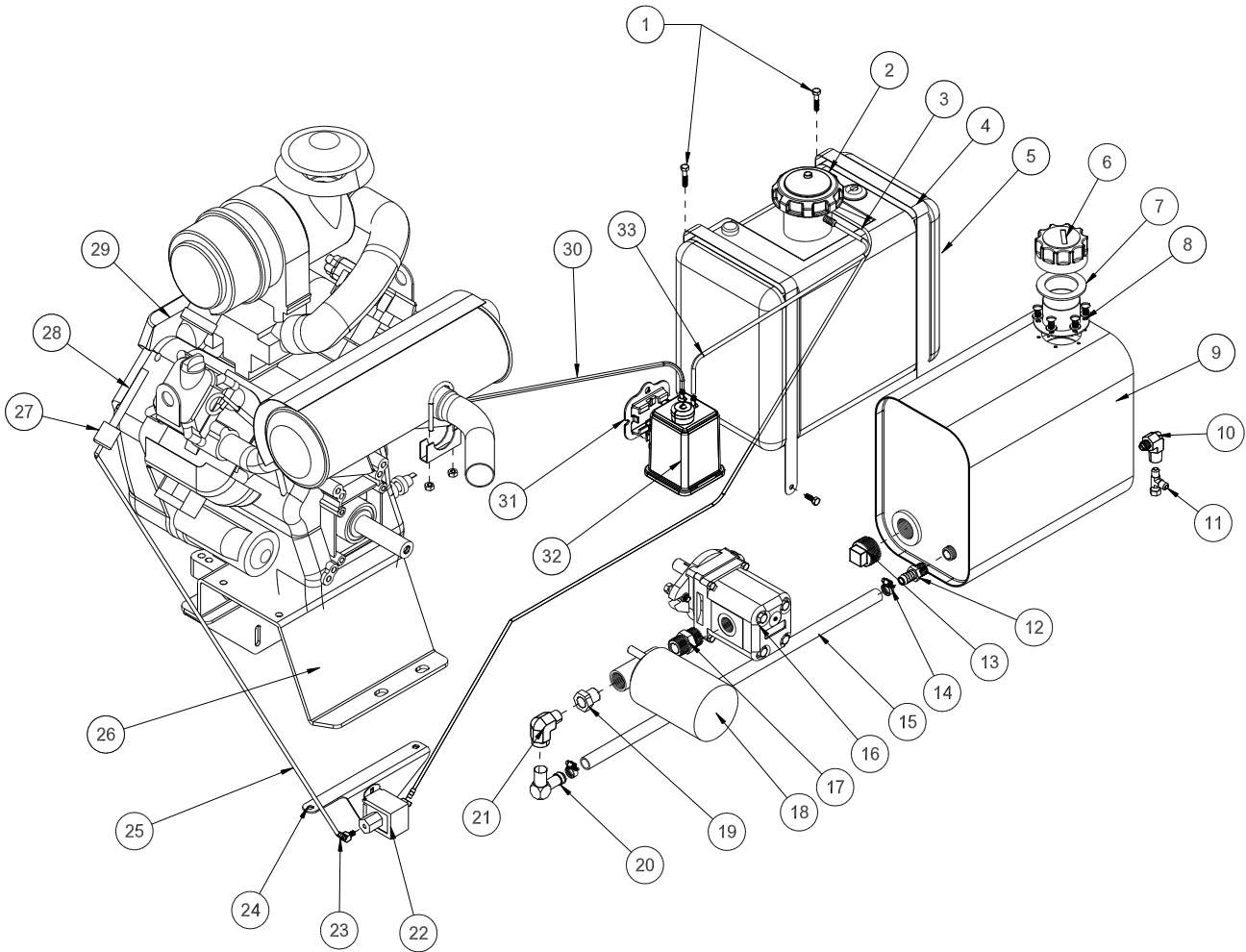

PARTS

GAS & OIL TANK PARTS LIST

REF#	PART#	DESCRIPTION	QUANTITY
1	HB-14-20-150	Hex Bolt, 1/4 - 20 x 1 1/2	2
	HNTL-14-20	Nylon Lock Nut, 1/4 - 20	2
2	73-050	Replacement Vented Cap	
3	8800-40	Fuel Line 40"	1
	18-186	Hose Clamp	2
4	78-456	Tank Straps	2
5	15-838	6 Gallon CARB Gas Tank	1
	15-838-01	Fuel Gauge	1
	42-814-08	Gauge Grommet	1
	42-814-07	TOP Draw Grommet	1
6	13-747	Filler Breather Cap	1
	13-586-01	Cap Gasket	1
7	13-586-03	Neck	1
	13-586-02	Bottom Gasket	1
8	HSM-10-32-063	Machine Screw, 10-32 x 5/8	6
	HWL-10	Lock Washer	6
9	60-473	Oil Tank	1
10	17-019	Male Elbow	1
11	18-190	Tee	1
12	23-139	Barb Fitting	1
13	18-098	Plug, 1 1/4	1
14	18-040	Hose Clamp	2
15	8917	Suction Hose, 5/8 ID	1
16	78-413	Hydraulic Pump (no parts available for service)	1
17	18-332	Adapter	1
18	23-006	Oil Filter	1
	23-031	Replacement Filter Only	
19	18-008	Pipe Reducer	1
20	23-142	Connector	1
21	18-009	Street Elbow	1
22	76-471	Fuel Pump	1
23	18-420	45° Barb	2
24	78-459	Fuel Pump Mount	1
25	8800-16	Fuel Line, 16"	1
	18-186	Hose Clamp	2
26	73-058	Engine Plate	1
27	50-403	In-line Fuel Filter	1
28	8800-14	Fuel Line, 14"	1
	18-186	Hose Clamp	2
29	76-484	31HP Vanguard Engine	1
30	8800-44	Fuel Line, 44"	1
	18-186	Hose Clamp	2
31	8-688	Canister Mount	1
32	8-689	CARB Canister	1
33	8800-27	Fuel Line, 27"	1
	18-186	Hose Clamp	2

PULLEY AND PUMP DRAWING

Parts

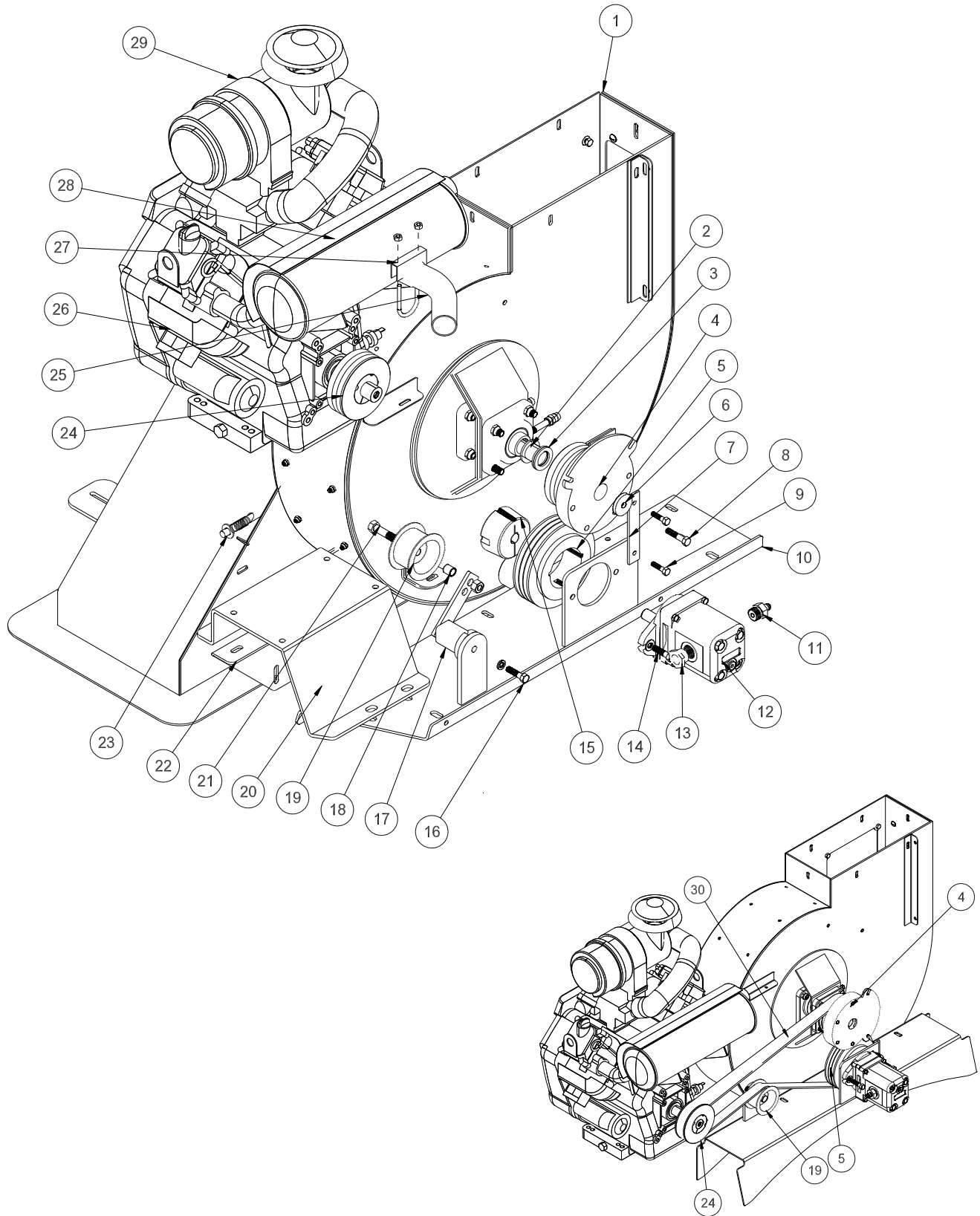

PULLEY AND PUMP PARTS LIST

REF#	PART#	DESCRIPTION	QUANTITY
1	78-375	Blower Housing	1
2	78-336	Vacuum Housing Shaft	1
3	HMB-118-10	Machine Bushing, 1 ¹ / ₈ x 10GA	2
	HMB-118-14	Machine Bushing, 1 ¹ / ₈ x 14GA	1
4	78-368	Electric Clutch	1
5	78-426	Pulley 3-Groove (pump)	1
6	78-370	Washer	1
7	76-340	Clutch Strap	1
8	HB-38-16-175	Hex Bolt, 3 ³ / ₈ - 16 x 1 ³ / ₄	1
9	HB-516-18-125	Hex Bolt, 5 ⁵ / ₁₆ - 18 x 1 ¹ / ₄	2
	HW-516	Flat Washer, 5 ⁵ / ₁₆	3
	HNTL-516-18	Nylon Lock Nut, 5 ⁵ / ₁₆ - 18	2
10	73-025	Blower Mount	1
11	18-331	Adapter	1
12	78-413	Hydraulic Pump (no parts available for service)	1
	HWK-316-063	Woodruff Key, 3 ³ / ₁₆ x 5 ⁵ / ₈	1
13	18-362	Adapter	1
14	HB-38-16-150	Hex Bolt, 3 ³ / ₈ - 16 x 1 ¹ / ₂	2
	HW-38	Flat Washer, 3 ³ / ₈	4
	HNTL-38-16	Nylon Lock Nut, 3 ³ / ₈ - 16	2
15	42-246	Hub, 3 ³ / ₄	1
	HSSHS-12-13-100	Set Screw, 1 ¹ / ₂ - 13 x 1 (part of 42-246)	2
16	HBM-10-1.5-30	Metric Hex Bolt, 10-1.5 x 30 (part of 78-224)	1
	HWLM-10	Metric Lock Washer, #10 (part of 78-224)	1
17	78-224	Belt Tensioner	1
18	76-275	Spacer (part of 78-224)	1
19	16-013	Idler Pulley	1
20	73-058	Engine Plate	1
21	HB-12-13-250	Hex Bolt, 1 ¹ / ₂ - 13 x 2 ¹ / ₂ (part of 78-224)	1
	HMB-12-14	Machine Bushing, 1 ¹ / ₂ - 14GA	2
	HNCL-12-13	Center Nylon Lock Nut, 1 ¹ / ₂ - 13 (part of 78-224)	1
22	73-020	Engine Support	1
23		Flapper (part of housing)	1
	19-205	Spring	1
	HP-18-100	Cotter Pin, 1 ¹ / ₈ x 1	1
24	78-424	Pulley	1
	78-427	Hub, 1 ¹ / ₈	1
	HSSHS-38-16-063	Set Screw, 3 ³ / ₈ - 16 x 5 ⁵ / ₈ (part of 78-427)	2
25	73-062	Tail Pipe	1
26	76-484	31HP Vanguard Engine	1
27	50-394	Muffler Clamp	1
28	76-447	Muffler	1
29	76-395-04	Cyclonic Air Cleaner	1
30	78-227	Belt	1

VACUUM AND BLOWER DRAWING

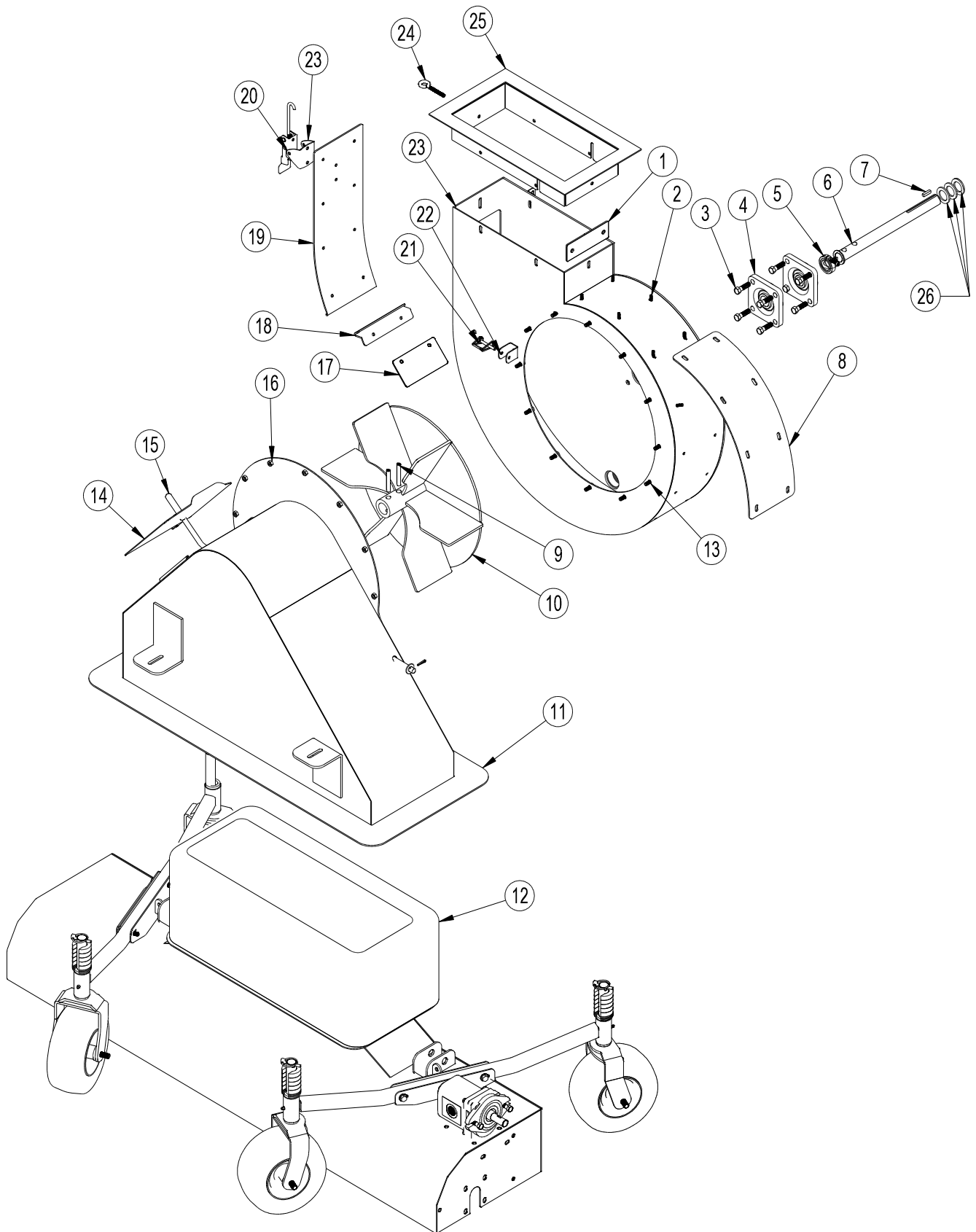

Parts

VACUUM AND BLOWER PARTS LIST

REF#	PART#	DESCRIPTION	QUANTITY
1	78-419	Bottom Lining Holder	1
2	HSTP-14-20-075	Phillips Truss Head Machine Screw, 1/4 -20 x 3/4	20
	HSTP-14-20-100	Phillips Truss Head Machine Screw, 1/4 -20 x 1	12
	HWF-14-150	Fender Washer, 1/4 x 1 1/2	32
	HNTL-14-20	Nylon Lock Nut, 1/4 -20	32
3	HB-716-14-150	Hex Bolt, 7/16 -14 x 1 1/2	8
	HNTL-716-14	Nylon Lock Nut, 7/16 -14	8
4	78-223	Mounted Bearing (1 1/8" Bore)	2
5	78-437	Shaft Collar	1
6	78-336	Vacuum Housing Shaft	1
7	HKSQ-14-100	Machine Key, 1/4 x 1/4 x 1	1
8	78-412	Wear Cover	1
9	78-347	Spiral Spring Pin	2
10	78-301	Balanced Fan	1
11	8803-114	Trim Black	1
12	72-140	Sweeper Boot	1
13	HBFL-516-18-075	Flange Whiz-loc Bolt, 5/16 -18 x 3/4	11
	HNTL-516-18	Nylon Lock Nut, 5/16 -18	7
	HNFL-516-18	Flange Whiz-loc Nut, 5/16 -18	4
14	78-293	Cover Plate	1
	HBfl-516-18-075	Flange Whiz-loc Bolt, 5/16 - 18 x 3/4	1
	HNTL-516-18	Nylon Lock Nut, 5/16 - 18	1
	78-433	Cover Plate Hex Bolt Tab	1
	HB-14-20-075	Hex Bolt, 1/4 - 20 x 3/4	1
	HNTL-14-20	Nylon Lock Nut, 1/4 - 20	1
15	25-120	Handle Grip	1
	19-205	Spring	1
	HP-18-100	Cotter Pin, 1/8 x 1	1
16	73-027	Vacuum Housing	1
17	78-411	Top Lining Holder	1
18	78-440	Door Pivot	1
19	73-052	Access Panel	1
	78-403	Lining	1
20	48-115	Adjustable Draw Latch	1
	HSTP-14-20-075	Truss Head Machine Screw, 1/4 - 20 x 3/4	2
	78-432	Latch Keeper	1
	HB-516-18-250	Hex Bolt, 5/16 -18 x 2 1/2	1
	HNTL-516-18	Nylon Lock Nut, 5/16 -18	1
21	73-033	Handle Latch	1
22	29-541	Lock Pin	1
23	78-375	Blower Housing	1
	78-436	Pipe Plug	1
	78-402	Blower Lining	1
	HWF-14-150	Fender Washer, 1/4 x 1 1/2	32
24	20-008	Eye Hex Bolt	1
	HNFL-516-18	Flange Whiz-loc Nut, 5/16 -18	1
25	73-024	Chute Flange	1
	8947-64	Trim Seal - 64"	1
26	HMB-118-14	Machine Bushing, 1 1/8 - 14GA	1
	HMB-118-10	Machine Bushing, 1 1/8 - 10GA	2

HOPPER PARTS LIST

REF #	PART #	DESCRIPTION	QUANTITY
1	72-106	Left Hopper Side Frame	1
2	HB-14-20-250	Hex Bolt, 1/4 -20 x 2 1/2	15
	HNFL-14-20	Flange Whiz-loc Nut, 1/4 -20	15
3	72-115	Hopper Front	1
	HSDPS-14-075	Stainless Pan Head Drill Screw, 1/4 x 3/4	9
4	72-110	Hopper Chute	1
	HSTP-14-20-075	Phillip Head Machine Screw, 1/4 -20 x 3/4	6
	HNFL-14-20	Flange Whiz-loc Nut, 1/4 - 20	6
5	HBFL-516-18-075	Flange Whiz-loc Bolt, 5/16 -18 x 3/4	10
	HNFL-516-18	Flange Whiz-loc Nut ,5/16 -18	10
6	8947-18	Trim Seal	2
7	73-024	Chute Flange	1
	8947-64	Trim Seal - 64"	1
8	73-026	Debris Chute	1
	8980-60	Edge Seal	1
9	72-107	Hopper Top	1
10	72-102	Left Hopper Cover	1
11	HW-14	Washer 1/4	10
12	HSDPS-14-075	Stainless Pan Head Drill Screw, 1/4 x 3/4	6
13	HB-14-20-075	Hex Bolt, 1/4 -20 x 3/4	23
	HNFL-14-20	Flange Whiz-loc Nut, 1/4 -20	23
14	72-101	Right Hopper Cover	1
15	72-124	Hood Stiffener	1
16	72-105	Right Hopper Side Frame	1
17	72-138	Slide Strip	2
	HRS-316-075	Pop Rivet, 3/16	8
18	72-137	Hopper Side	2
	HSDPS-14-075	Stainless Pan Head Drill Screw, 1/4 x 3/4	82
19	HB-14-20-175	Hex Bolt, 1/4 -20 x 1 3/4	14
	HNFL-14-20	Flange Whiz-loc Nut, 1/4 - 20	14
20	72-116	Tailgate	1
21	HB-12-13-175	Hex Bolt, 1/2 -13 x 1 3/4	4
	HNFL-12-13	Flange Whiz-loc Nut, 1/2 - 13	4
22	72-098	Hopper Floor	1
23	72-123	Pivot Pin	2
	HP-18-100	Cotter Pin, 1/8 x 1	4
24	HSTP-14-20-075	Phillip Head Machine Screw, 1/4 -20 x 3/4	18
	HNFL-14-20	Flange Whiz-loc Nut, 1/4 - 20	18
25	72-118	Short Tailgate Lift Arm	2
	18-234	Bushing (part of 72-118)	1
	HMB-12-14	Machine Bushing, 1/2 x 14 GA	6
	HP-18-100	Cotter Pin, 1/8 x 1	2
26	72-117	Long Tailgate Lift Arm	2
	18-234	Bushing (part of 72-117)	2
	HMB-12-14	Machine Bushing, 1/2 x 14 GA	6
	HP-18-100	Cotter Pin, 1/8 x 1	2

78-416 3-BANK HYDRAULIC VALVE DRAWING

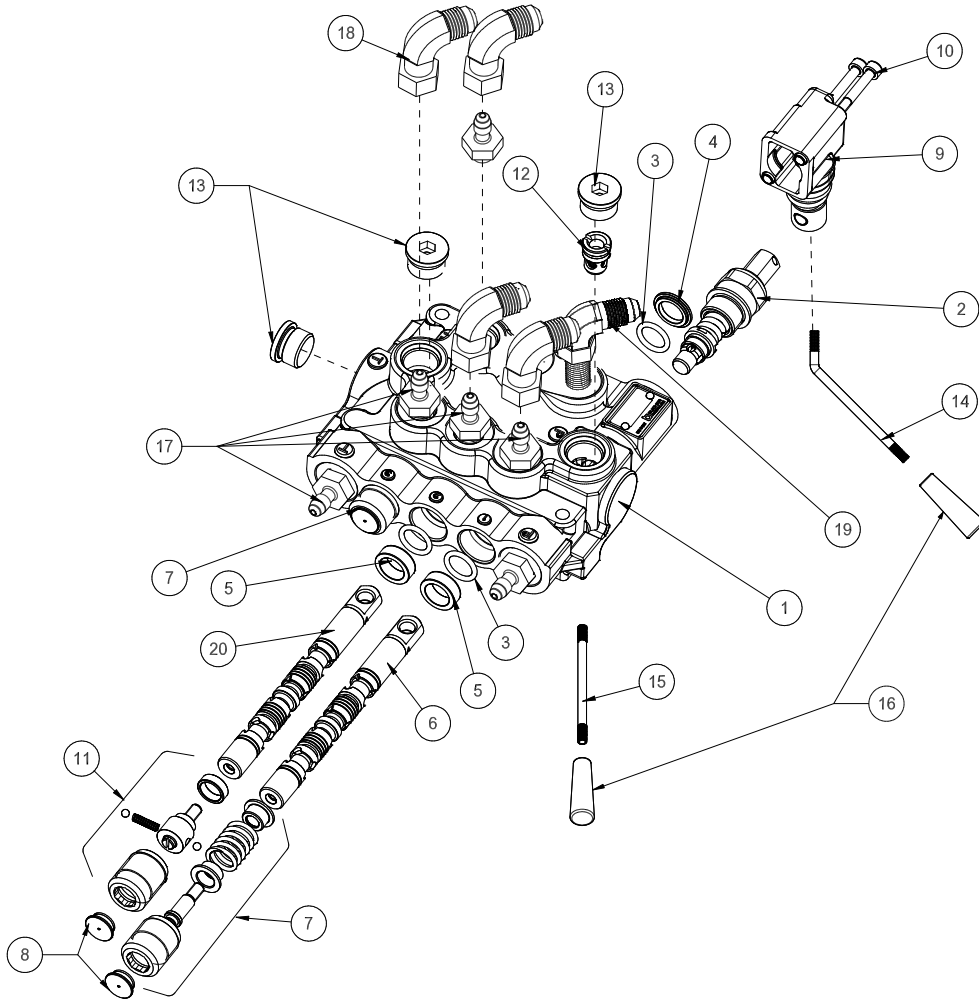

Parts

78-416 3-BANK HYDRAULIC VALVE PARTS LIST

REF#	PART#	DESCRIPTION	QUANTITY
1*	78-416-01	Body (complete with spacer and check valve)	1
2*	78-415-02	Spool HDM10	1
3*	78-415-03	O-Ring Seal	6
4*	78-415-04	Flanged Washer HDM10	3
5*	78-415-05	Spacer	3
6*	78-415-06	A Type Spool HDS11	2
7*	78-415-11	Positioner HDM10	2
8*	78-415-08	Plug	3
9*	78-415-09	Lever Group HDS11	3
10*	78-415-10	Metric Socket Screw M5 x .8 x 45	6
11*	78-415-07	Positioner	1
12*	78-415-12	Check Valve Assembly HDM12	1
13*	78-415-13	³ / ₄ - 16 SAE 8 Screw Plug	3
14	78-418	Bent Handle	2
15	78-417	Straight Handle (center)	1
16	78-417-01	Tapered Knob	3
17	18-169	Adapter SAE 3/8	6
18	18-202	Elbow	4
19	18-168	Elbow 3/8 Straight Thread	1
20		C- Type Spool	1
* 78-416		3 – Bank Hydraulic Valve (includes all * items)	

AXLE DRAWING

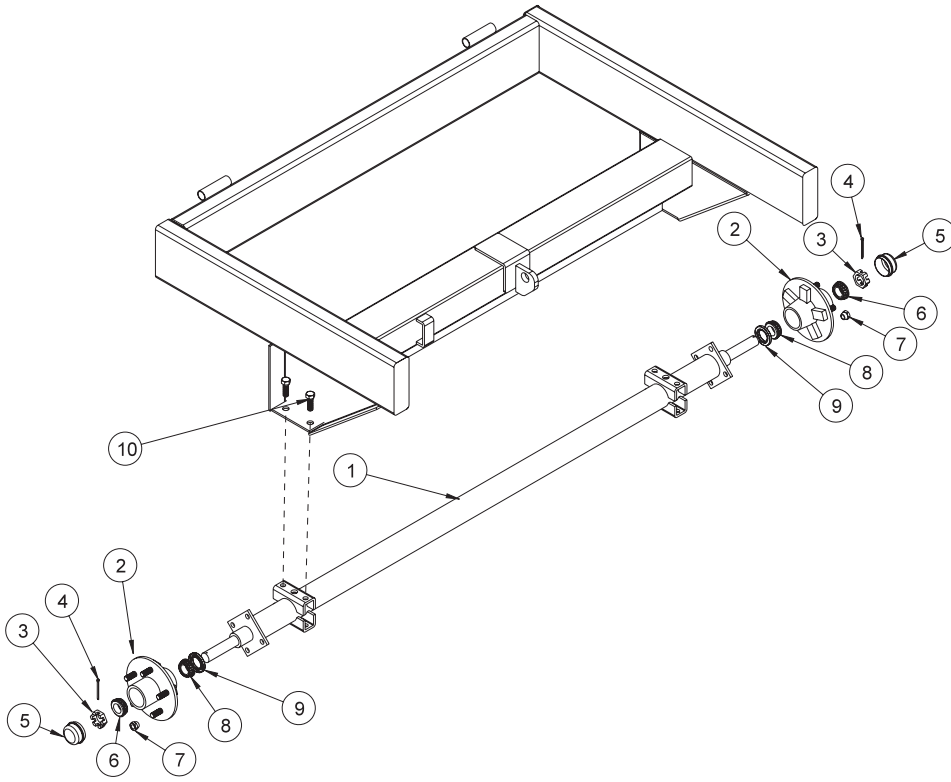

Parts

AXLE PARTS LIST

REF #	PART #	DESCRIPTION	QUANTITY
1	72-194	Axle (includes all items listed below except #10)	1
2	33-074	Hub Assembly (includes all * items listed below)	2
3	HNAR-100-14	Slotted Jam Nut, 1-14	2
4	HP-18-200	Cotter Pin, 1/8 x 2	2
5*	33-073-02	Dust Cap	2
6*	78-119	Outer Bearing	2
7*	HNL-12-20	Lug Nut	10
8*	78-118	Inter Bearing	2
9*	33-073-01	Grease Seal	2
10	HB-12-13-125	Hex Bolt, 1/2 - 13 x 1 1/4	4
	HNTL-12-13	Nylon Lock Nut, 1/2 - 13	4

72-002 RUBBER FINGER SWEEPER HEAD DRAWING

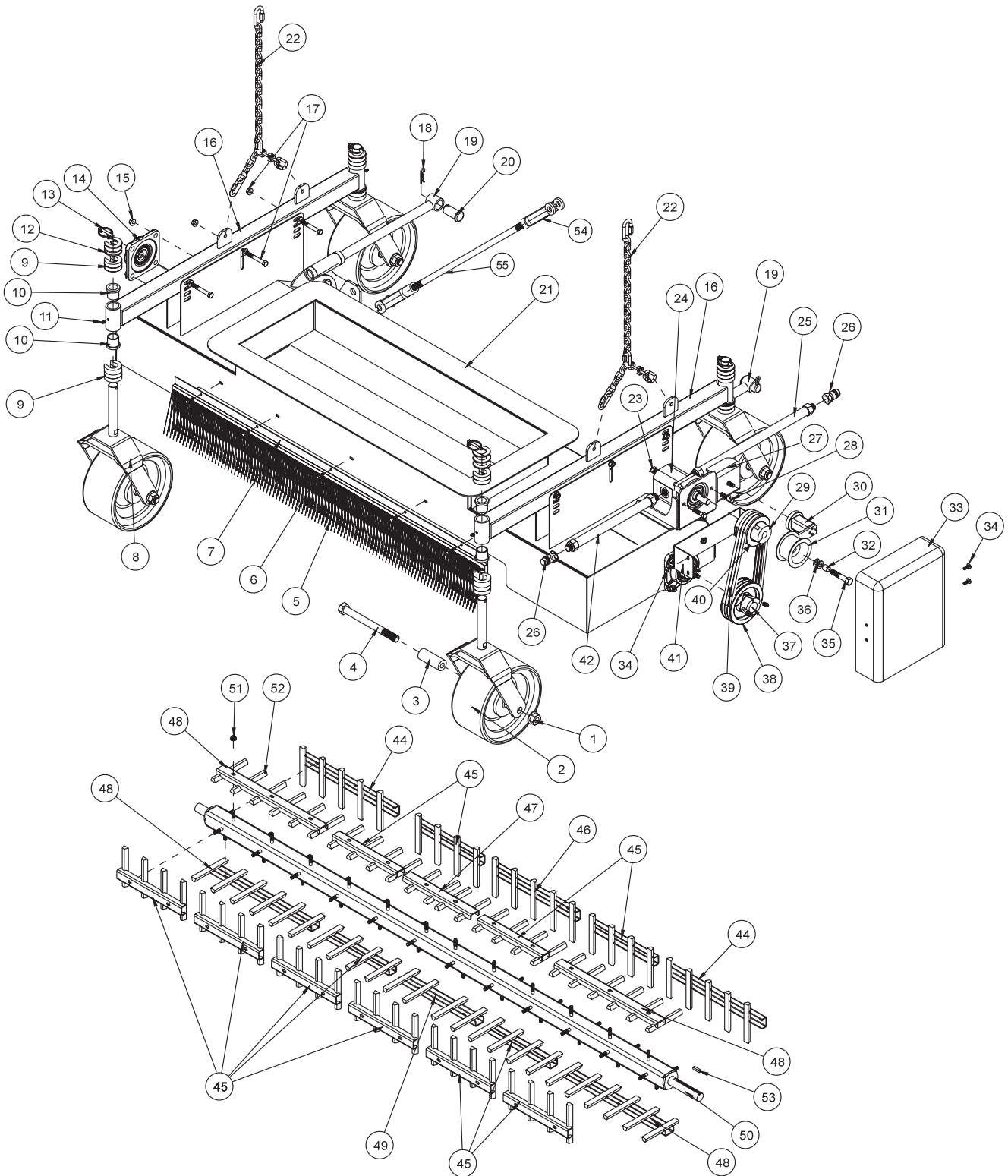

Accessories

72-002 RUBBER FINGER SWEEPER HEAD PARTS LIST

REF#	PART#	DESCRIPTION	QUANTITY
1	HNTL-34-10	Nylon Lock Nut, $\frac{3}{4}$ - 10	4
2	78-012	Tire and Wheel	4
	78-012-01	Bearing (part of 78-012)	2 per Wheel
3	72-135	Castor Wheel Spacer	8
4	HB-34-10-800	Hex Bolt, $\frac{3}{4}$ - 10 x 8	4
5	78-322	Brush	1
6	HB-14-20-075	Hex Bolt, $\frac{1}{4}$ - 20 x $\frac{3}{4}$	5
	HNFL-14-20	Flange Whiz-loc Nut, $\frac{1}{4}$ - 20	5
7	78-344	Brush Holder	1
8	72-134	Castor Fork	4
9	72-053	Quick Spacer, $\frac{1}{2}$ "	20
10	18-223	Flange Bushing (part of 72-139)	8
11	HG-14-28-180	Grease Fitting, $\frac{1}{4}$ - 28 x 180° (part of 72-139)	2
12	72-136	Quick Spacer 10GA	12
13	42-539	Lynch Pin, $\frac{5}{16}$	4
14	72-023	Flange Bearing	2
	HG-14-28-180	Grease Fitting, $\frac{1}{4}$ - 28 x 180° (part of 72-023)	2
15	HNFL-38-16	Flange Whiz-loc Nut, $\frac{3}{8}$ - 16	8
	HB-38-16-125	Hex Bolt, $\frac{3}{8}$ - 16 x $1\frac{1}{4}$	8
16	72-139	Single Castor Wheel Arm	2
17	HB-38-16-275	Hex Bolt, $\frac{3}{8}$ - 16 x $2\frac{3}{4}$	6
	HW-38	Flat Washer, $\frac{3}{8}$	6
	HNFL-38-16	Flange Whiz-loc Nut, $\frac{3}{8}$ - 16	6
18	HHP-18-100	Bridge Pin, $\frac{1}{8}$ x 1	4
19	72-103	Reel Lift Rod	2
20	HCP-100-250	Clevis Pin, 1 x 2	4
21	72-133	Single Reel Housing	1
	8803-114	Trim Black with Lace, 114"	1
22	72-144	Single Reel Lift Chain	2
23	18-362	Straight Thread Reducer	1
24†	72-199	Hydraulic Motor	1
25	72-075	Hydraulic Hose, 48"	1
26	72-043	$\frac{1}{2}$ " Male Quick Coupler	2
27	72-097	Motor Mount	1
	HB-38-16-100	Hex Bolt, $\frac{3}{8}$ - 16 x 1	4
	HW-38	Flat Washer, $\frac{3}{8}$	4
	HNFL-38-16	Flange Whiz-loc Nut, $\frac{3}{8}$ - 16	4
28	HB-38-16-125	Hex Bolt, $\frac{3}{8}$ - 16 x $1\frac{1}{4}$	2
	HW-38	Flat Washer, $\frac{3}{8}$	2
	HNTL-38-16	Nylon Lock Nut, $\frac{3}{8}$ - 16	2
29	78-428	Hub	1
	HSSHS-38-16-063	Set Screw, $\frac{3}{8}$ - 16 x $\frac{5}{8}$ (part of 78-237)	2

(Continued on next page)

†	72-199-01	Seal kit	1 per
	HWK-316-063	Woodruff Key, $\frac{3}{16}$ x $\frac{5}{8}$	1 per

No other parts are replaceable for hydraulic motors.

72-002 RUBBER FINGER SWEEPER HEAD DRAWING

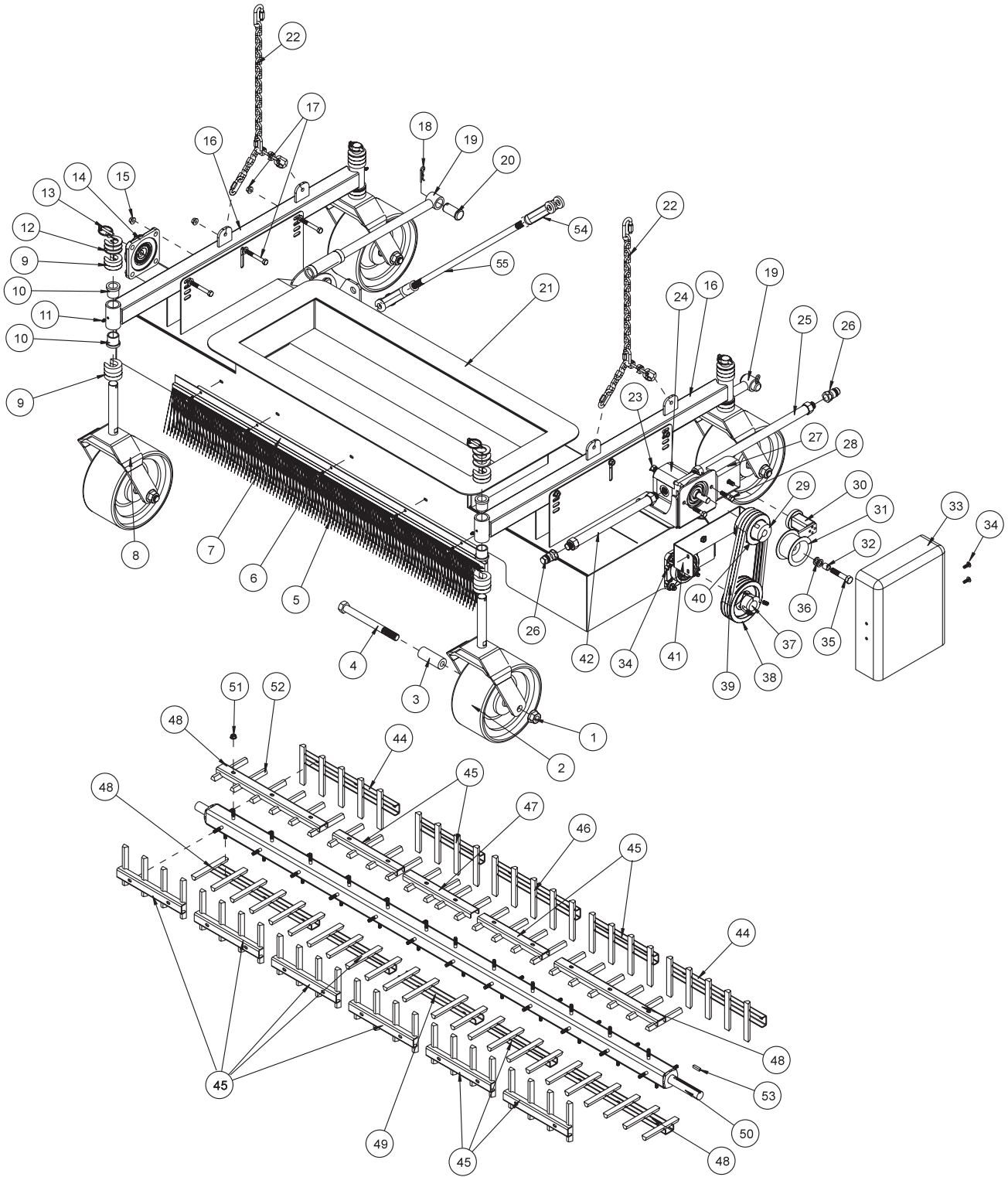

Accessories

72-002 RUBBER FINGER SWEEPER HEAD PARTS LIST

REF#	PART#	DESCRIPTION	QUANTITY
30	78-224	Belt Tensioner	1
	HBM-10-1.50-30	Metric Hex Bolt, 10 - 1.50 x 30 (part of 78-224)	1
	HWLM-10	Metric Lock Washer, 10 (part of 78-224)	1
31	16-013	Idler pulley	1
32	76-275	Spacer (part of 78-224)	1
33	72-056	Belt Guard	1
34	HSTP-14-20-075	Phillip Head Machine Screw, 1/4 - 20 x 3/4	4
	HNFL-14-20	Flange Whiz-loc Nut, 1/4 - 20	4
35	HB-12-13-250	Hex Bolt, 1/2 - 13 x 2 1/2 (part of 78-224)	1
	HNCL-12-13	Center Nylon Lock Nut, 1/2 - 13 (part of 78-224)	1
36	HMB-12-14	Machine Bushing, 1/2 x 14GA	2
37	78-431	Hub, 1 1/4	1
	HSSHS-38-16-063	Set Screw, 3/8 - 16 x 5/8 (part of 72-035)	2
38	78-425	Pulley	1
39	72-038	Belt	3
40	78-424	Pulley	1
41	72-058	Belt Guard Mount	1
	HB-516-18-075	Hex Bolt, 5/16 - 18 x 3/4	2
	HW-516	Flat Washer, 5/16	2
	HNFL-516-18	Flange Whiz-loc Nut, 5/16 - 18	2
42	72-074	Hydraulic Hose, 39"	1
44	72-091	Finger Clamp, 14 3/4"	2
45	78-297	Finger Clamp, 10"	12
46	78-287	Finger Clamp, 13"	1
47	78-327	Finger Clamp, 10 1/2"	1
48	72-092	Finger Clamp, 16"	4
49	78-326	Finger Clamp, 12"	1
50	72-125	Finger Reel	1
51	HNFL-516-18	Flange Whiz-loc Nut, 5/16 - 18	48
52	8969-5.250	Sweeper Finger	96
53	HKSQ-14-100	Square Key, 1/4 x 1/4 x 1	1
54	42-040	Yoke End	2
	HNJ-34-16	Jam Nut, 3/4 - 16	2
	HCP-34-200	Clevis Pin, 3/4 x 2	2
	HHP-18	Bridge Pin, 1/8 x 1	2
55	42-148	Sway Bar	1

VERTICUT REEL VALVE HANDLE

⚠ CAUTION

If the rubber finger sweeper head is installed on your unit and verticut reel handle is activated, the hydraulic system may be damaged due to overheating the oil. Remove the verticut reel valve handle when using the rubber finger sweeper head (72-002).

72-005 BRUSH REEL SWEEPER HEAD DRAWING

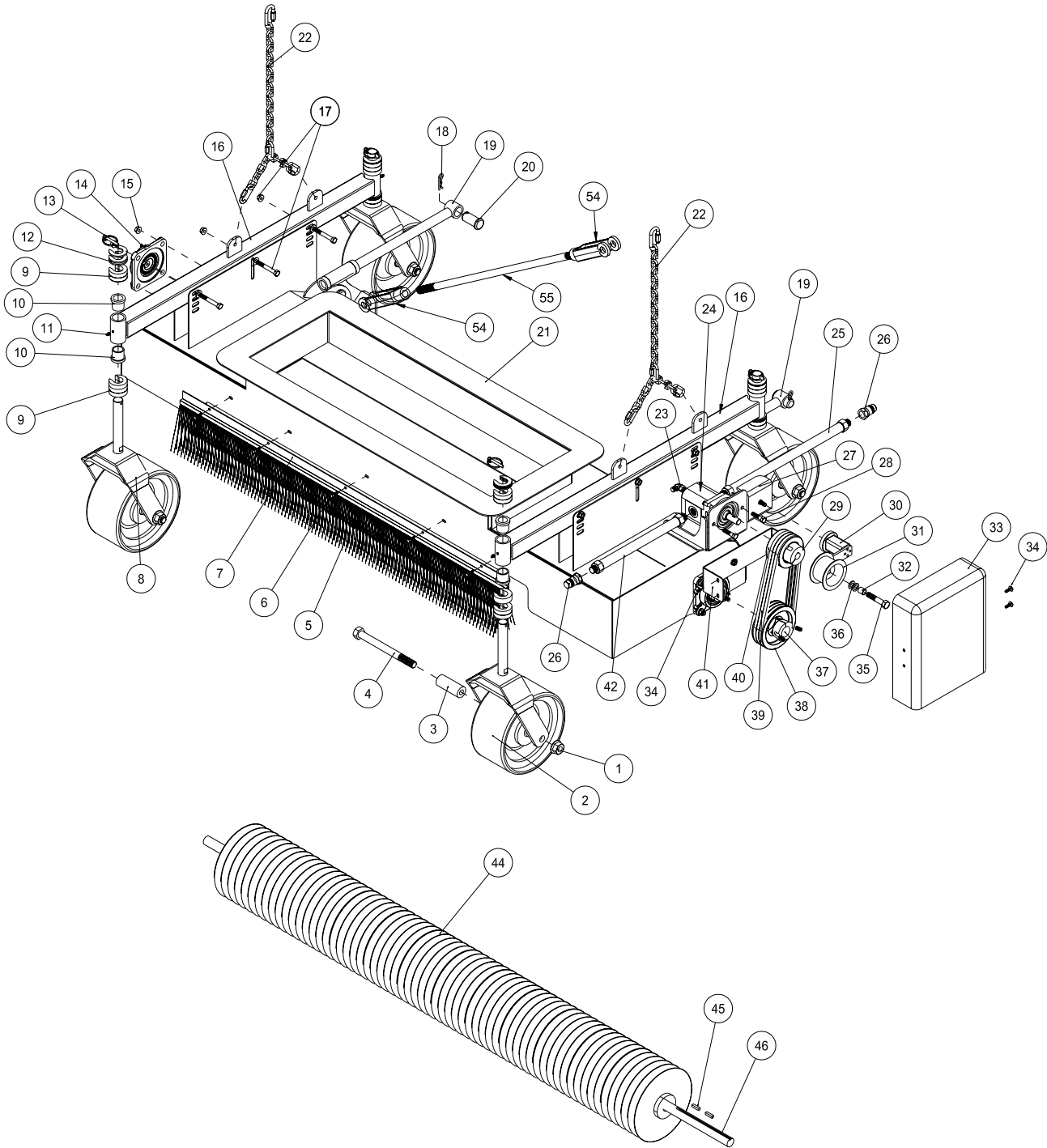

Accessories

72-005 BRUSH REEL SWEEPER HEAD PARTS LIST

REF#	PART#	DESCRIPTION	QUANTITY
1	HNTL-34-10	Nylon Lock Nut, $\frac{3}{4}$ - 10	4
2	78-012	Tire and Wheel	4
	78-012-01	Bearing (part of 78-012)	2 per Wheel
3	72-135	Castor Wheel Spacer	8
4	HB-34-10-800	Hex Bolt, $\frac{3}{4}$ - 10 x 8	4
5	78-322	Brush	1
6	HB-14-20-075	Hex Bolt, $\frac{1}{4}$ - 20 x $\frac{3}{4}$	5
	HNFL-14-20	Flange Whiz-loc Nut, $\frac{1}{4}$ - 20	5
7	78-344	Brush Holder	1
8	72-134	Castor Fork	4
9	72-053	Quick Spacer, $\frac{1}{2}$ "	20
10	18-223	Flange Bushing (part of 72-139)	8
11	HG-14-28-180	Grease Fitting, $\frac{1}{4}$ - 28 x 180° (part of 72-139)	2
12	72-136	Quick Spacer, 10GA	12
13	42-539	Lynch Pin, $\frac{5}{16}$	4
14	72-023	Flange Bearing	2
	HG-14-28-180	Grease Fitting, $\frac{1}{4}$ - 28 x 180° (part of 72-023)	2
15	HNFL-38-16	Flange Whiz-loc Nut, $\frac{3}{8}$ - 16	8
	HB-38-16-125	Hex Bolt, $\frac{3}{8}$ - 16 x $1\frac{1}{4}$	8
16	72-139	Single Castor Wheel Arm	2
17	HB-38-16-275	Hex Bolt, $\frac{3}{8}$ - 16 x $2\frac{3}{4}$	6
	HW-38	Flat Washer, $\frac{3}{8}$	6
	HNFL-38-16	Flange Whiz-loc Nut, $\frac{3}{8}$ - 16	6
18	HHP-18-100	Bridge Pin, $\frac{1}{8}$ x 1	4
19	72-103	Reel Lift Rod	2
20	HCP-100-250	Clevis Pin, 1 x 2	4
21	72-133	Single Reel Housing	1
	8803-114	Trim Black with Lace, 114"	1
22	72-076	Hydraulic Hose, 22"	1
23	18-168	Elbow	1
24†	78-219	Hydraulic Motor	1
25	72-075	Hydraulic Hose, 48"	1
26	72-043	$\frac{1}{2}$ " Male Quick Coupler	2
27	72-097	Motor Mount	1
	HB-38-16-100	Hex Bolt, $\frac{3}{8}$ - 16 x 1	4
	HW-38	Flat Washer, $\frac{3}{8}$	4
	HNFL-38-16	Flange Whiz-loc Nut, $\frac{3}{8}$ - 16	4
28	HB-38-16-125	Hex Bolt, $\frac{3}{8}$ - 16 x $1\frac{1}{4}$	2
	HW-38	Flat Washer, $\frac{3}{8}$	2
	HNTL-38-16	Nylon Lock Nut, $\frac{3}{8}$ - 16	2
29	78-428	Hub	1
	HSSHS-38-16-063	Set Screw, $\frac{3}{8}$ - 16 x $\frac{5}{8}$ (part of 78-237)	2

(Continued on next page)

†	78-219-01	Seal kit	1 per
	78-219-02	Driver Coupler	1 per
	HWK-316-063	Woodruff Key, $\frac{3}{16}$ x $\frac{5}{8}$	1 per

No other parts are replaceable for hydraulic motors.

72-005 BRUSH REEL SWEEPER HEAD DRAWING

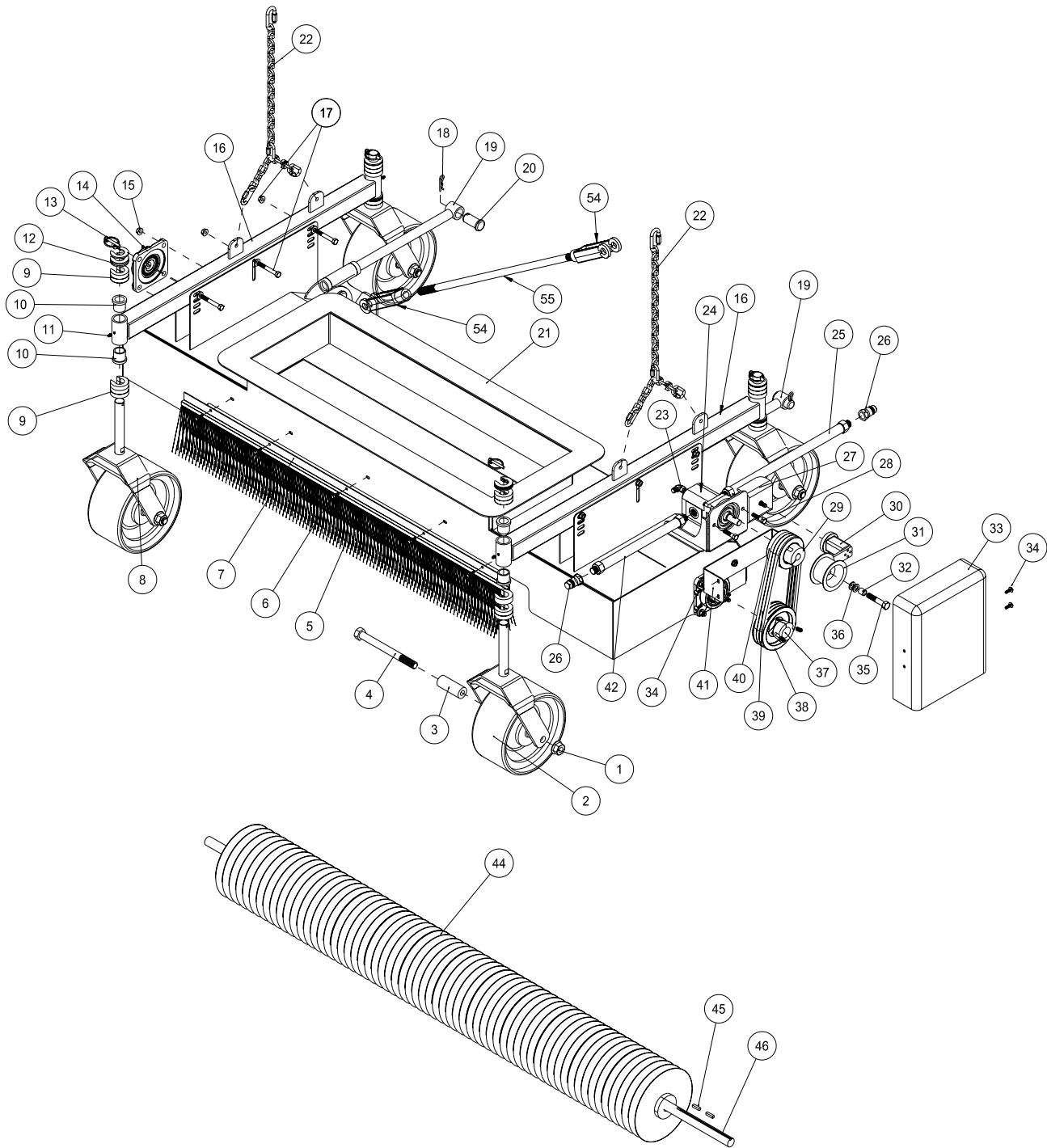

Accessories

72-005 BRUSH REEL SWEEPER HEAD PARTS LIST

REF#	PART#	DESCRIPTION	QUANTITY
30	78-224	Belt Tensioner	1
	HBM-10-1.50-30	Metric Hex Bolt, 10 - 1.50 x 30 (part of 78-224)	1
	HWLM-10	Metric Lock Washer, 10 (part of 78-224)	1
31	16-013	Idler pulley	1
32	76-275	Spacer (part of 78-224)	1
33	72-056	Belt Guard	1
34	HSTP-14-20-075	Phillip Head Machine Screw, 1/4 - 20 x 3/4	4
	HNFL-14-20	Flange Whiz-loc Nut, 1/4 - 20	4
35	HB-12-13-250	Hex Bolt, 1/2 - 13 x 2 1/2 (part of 78-224)	1
	HNCL-12-13	Center Nylon Lock Nut, 1/2 - 13 (part of 78-224)	1
36	HMB-12-14	Machine Bushing, 1/2 x 14GA	2
37	78-431	Hub, 1 1/4	1
	HSSHS-38-16-063	Set Screw, 3/8 - 16 x 5/8 (part of 72-035)	2
38	78-425	Pulley	1
39	72-038	Belt	3
40	78-424	Pulley	1
41	72-058	Belt Guard Mount	1
	HB-516-18-075	Hex Bolt, 5/16 - 18 x 3/4	2
	HW-516	Flat Washer, 5/16	2
	HNFL-516-18	Flange Whiz-loc Nut, 5/16 - 18	2
42	72-074	Hydraulic Hose, 39"	1
43	72-045	3/8 Female Quick Coupler	1
44*	72-188	Spiral Brush	1
45*	HKSQ-14-100	Square Key, 1/4 x 1/4 x 1	2.
46*	72-189	Shaft	1
47	72-144	Single Reel Lift Chain	2
48	72-148	Sway Bar	1
49	42-040	Yoke End	2
	HNJ-34-16	Jam Nut, 3/4 - 16	2
	HCP-34-200	Clevis Pin, 3/4 x 2	2
	HHP-18	Bridge Pin, 1/8 x 1	2
*	72-006	Brush Head Only (includes * items)	

73-003 STANDARD CLEVIS HITCH DRAWING

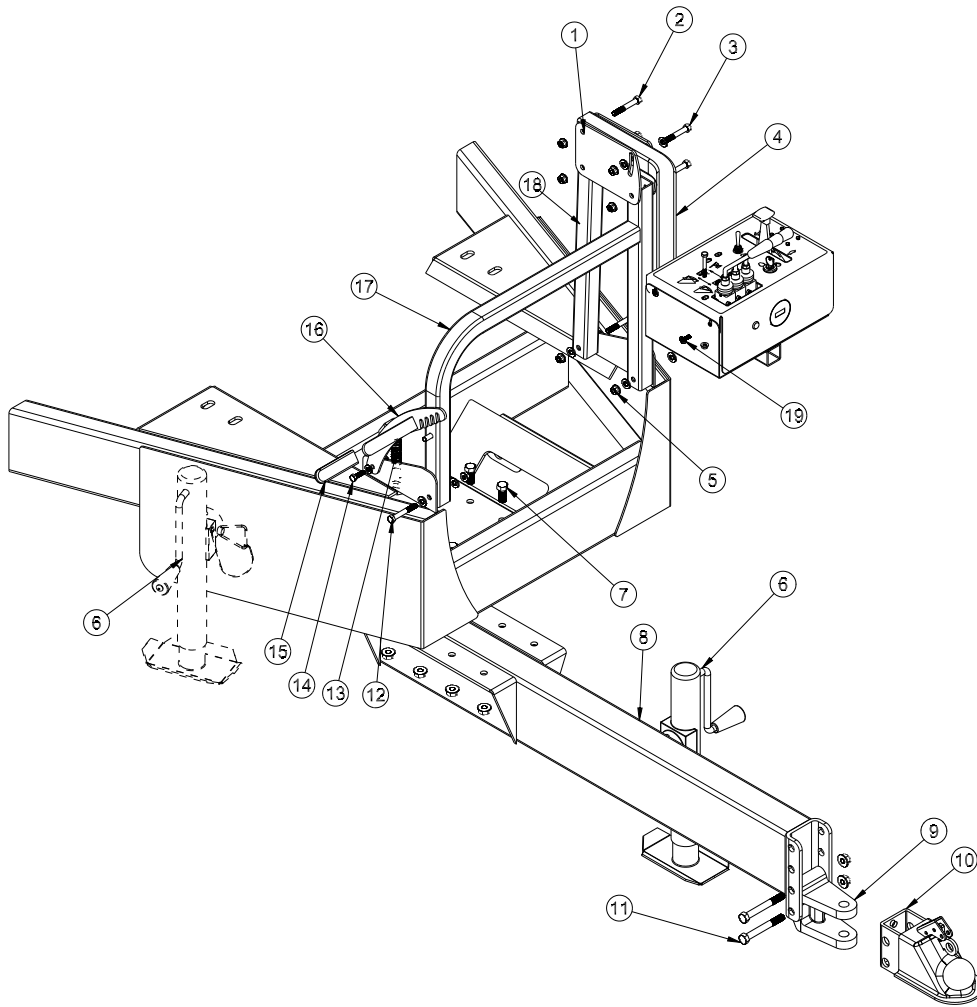

Accessories

73-003 STANDARD CLEVIS HITCH PARTS LIST

REF#	PART#	DESCRIPTION	QUANTITY
1	72-119	Control Panel Adjustment	2
2	HB-38-16-250	Hex Bolt, $\frac{3}{8}$ - 16 x 2 $\frac{1}{2}$	3
	HNTL-38-16	Nylon Lock Nut, $\frac{3}{8}$ - 16	3
3	HB-38-16-275	Hex Bolt, $\frac{3}{8}$ - 16 x 2 $\frac{3}{4}$	1
	HW-38	Flat Washer, $\frac{3}{8}$	2
	HNTL-38-16	Nylon Lock Nut, $\frac{3}{8}$ - 16	1
4	73-040	Control Panel Mount	1
5	HB-38-16-250	Hex Bolt, $\frac{3}{8}$ - 16 x 2 $\frac{1}{2}$	2
	HW-38	Flat Washer, $\frac{3}{8}$	4
	HNTL-38-16	Nylon Lock Nut, $\frac{3}{8}$ - 16	2
6	78-240	Jack (part of machine)	1
7	HB-12-13-125	Hex Bolt, $\frac{1}{2}$ - 13 x 1 $\frac{1}{4}$	8
	HNTL-12-13	Nylon Lock Nut, $\frac{1}{2}$ - 13	8
8	72-086	Tongue	1
9	78-244	Adjustable, $\frac{3}{4}$ " Clevis Hitch	1
10	78-245	2 $\frac{5}{16}$ Ball Hitch (Optional)	
11	HB-58-11-400	Hex Bolt, $\frac{5}{8}$ - 11 x 4	2
	HNCL-58-11	Center Nylon Lock Nut, $\frac{5}{8}$ - 11	2
12	HB-38-16-250	Hex Bolt, $\frac{3}{8}$ - 16 x 2 $\frac{1}{2}$	1
	HW-38	Flat Washer, $\frac{3}{8}$	2
	HNTL-38-16	Nylon Lock Nut, $\frac{3}{8}$ - 16	1
13	60-323	Spring	1
14	HB-516-18-100	Hex Bolt, $\frac{5}{16}$ - 18 x 1	1
	HW-516	Flat Washer, $\frac{5}{16}$	2
	HNTL-516-18	Nylon Lock Nut, $\frac{5}{16}$ - 18	1
15	15-020	Hand Grip	1
16	72-093	Adjustment Lock Arm	1
17	72-121	Control Panel Leg	1
18	72-120	Adjustment Leg	1
19	HST-14-20-075	Truss Head Hex Bolt, $\frac{1}{4}$ - 20 x $\frac{3}{4}$	4
	HNFL-14-20	Flange Whiz-loc Nut, $\frac{1}{4}$ - 20	4

INSTALLATION INSTRUCTIONS

Use two people to install hitches.

1. Block both wheels so machine does not roll.
2. Use the jack that is part of the sweeper to raise or lower sweeper to comfortable working height.
3. Slide the tongue (Ref 8) under the sweeper frame. Use the eight $\frac{1}{2}$ - 13 x 1 $\frac{1}{4}$ Hex Bolts (Ref 7) and Nylon Lock Nuts to secure tongue. Tighten all hardware.
4. Block up machine and remove jack from machine and place it on the tongue. Use the jack here for more support.
5. Install the control panel leg (Ref 17) and the adjustment leg (Ref 18) as shown, using two $\frac{3}{8}$ - 16 x 2 $\frac{1}{2}$ Hex Bolts (Ref 5 and 12). Install the control panel adjustment plates (Ref 1) using hardware (Ref 2 and 3) as shown. Install control panel arm (Ref 4).
6. Install the adjustment lock arm (Ref 16) with the Hex Bolt and the spring (Ref 13 and 14) as shown. Put the hand grip (Ref 15) on the arm. Tighten all hardware.
5. The control panel has all hose, wiring and throttle cable connected to it and the sweeper. The control panel is wrapped and fastened to the front of the sweeper.
6. Remove the control panel from the sweeper, bring it forward with the hoses to the rear and the throttle on the left hand side.
7. Fasten the control panel to the control panel mount with the four Truss Head Hex Bolts $\frac{1}{4}$ - 20 x $\frac{3}{4}$ (Ref 19) and four Flange Whiz-loc Nuts. Tighten all hardware.



Do not tow on public roads.



73-004 5TH WHEEL HITCH FOR TURF TRUCKSTER W/ ELECTRIC BRAKES

REF#	PART#	DESCRIPTION	QUANTITY
1	73-045	Hose Guard Cover	1
2	HSDPS-14-100	Pan Head Drill Screw, 1/4 x 1	2
	HW-14	Flat Washer, 1/4	2
3	HB-516-18-075	Hex Bolt, 5/16 - 18 x 3/4	4
	HNFL-516-18	Flange Whiz-loc Nut, 5/16 - 18	4
4	73-044	Hose Guard	1
5	73-038	5th Wheel Goose neck	1
6	HB-12-13-125	Hex Bolt, 1/2 - 13 x 1 1/4	8
	HNTL-12-13	Nylon Lock Nut, 1/2 - 13	8
7	73-041	LH Brake Assembly with Backplate	1
	73-042	RH Brake Assembly with Backplate	1
8	72-162	Hub & Drum Assembly	2
9	72-204-01	Tire	1
10	72-204-02	Wheel	2
11	HN-716-20	Hex Nut, 7/16 - 20	8
	HWL-716	Lock Washer, 7/16	8
12	25-358	Decal, Smithco	1
13	HB-516-18-100	Hex Bolt, 5/16 - 18 x 1	1
	HNTL-516-18	Nylon Lock Nut, 5/16-18	1
14	78-390	Ball Lock Arm	1
15	HB-14-20-075	Hex Bolt, 1/4 - 20 x 3/4	1
	HNTL-14-20	Nylon Lock Nut, 1/4 - 20	1
16	HB-38-16-225	Hex Bolt, 3/8 - 16 x 2 1/4	1
	HW-38	Flat Washer, 3/8	1
	HNTL-38-16	Nylon Lock Nut, 3/8 - 16	1
17	HB-38-16-225	Hex Bolt, 3/8 - 16 x 2 1/4	1
	HW-38	Flat Washer, 3/8	1
	HNW-38-16	Wing Nut, 3/8 - 16	1
18	78-352	Control Panel Mount	1
19	HST-14-20-075	Truss Head Hex Bolt, 1/4 - 20 x 3/4	4
	HNFL-14-20	Flange Whiz-loc Nut, 1/4 - 20	4

INSTALLATION INSTRUCTIONS

Use two people to install hitches.

1. Block both wheels so machine does not roll.
2. Use the jack that is part of the sweeper to raise or lower sweeper to comfortable working height.
3. Slide the goose neck (Ref 5) under the sweeper frame. Use the eight 1/2 - 13 x 1 1/4 Hex Bolts (Ref 6) and Nylon Lock Nuts onto secure goose neck. Tighten all hardware.
4. Install the control panel mount (Ref 19) on the front of the goose neck (Ref 5) as shown, using two 3/8 - 16 x 2 1/4 Hex Bolts (Ref 17 and 18). On the bottom Hex Bolt use Nylon Lock Nut (Ref 18) and just tighten snug. On the top Hex Bolt use the 3/8 washer and wing nut (Ref 17). Tighten both after adjusting for the proper position.
5. The control panel has all hose, wiring and throttle cable connected to it and the sweeper. The control panel is wrapped and fastened to the front of the sweeper.
6. Remove the control panel from the sweeper, bring it forward with the hoses to the rear and the throttle on the left hand side.
7. Fasten the control panel to the control panel mount with the four Truss Head Hex Bolts 1/4 - 20 x 3/4 (Ref 19) and four Flange Whiz-loc Nuts. Tighten all hardware.
9. Lay the hoses, wiring and throttle cable on top of the goose neck in hose guard(Ref 4). secure hose guard cover (Ref 1) with Hex Bolt 5/16 - 18 x 3/4 (Ref 3) and Flange Whiz-loc Nuts.



Do not tow on public roads.

73-005 5TH WHEEL HITCH

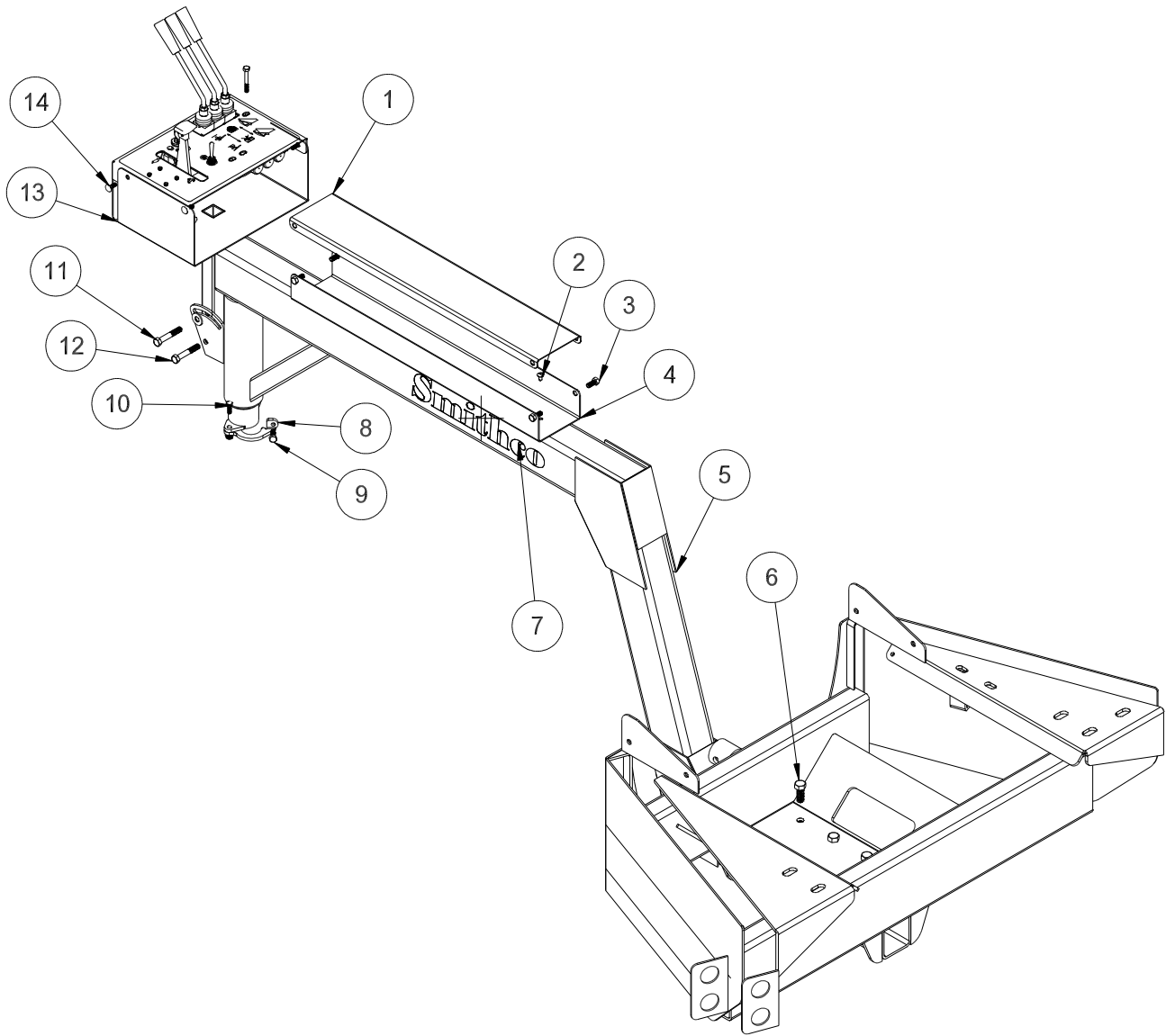

⚠ CAUTION

Do not tow on public roads.

73-005 5TH WHEEL HITCH

REF#	PART#	DESCRIPTION	QUANTITY
1	73-045	Hose Guard Cover	1
2	HSDPS-14-100	Pan Head Drill Screw, 1/4 x 1	2
	HW-14	Flat Washer, 1/4	2
3	HB-516-18-075	Hex Bolt, 5/16 - 18 x 3/4	4
	HNFL-516-18	Flange Whiz-loc Nut, 5/16 - 18	4
4	73-044	Hose Guard	1
5	73-038	5th Wheel Goose neck	1
6	HB-12-13-125	Hex Bolt, 1/2 - 13 x 1 1/4	8
	HNTL-12-13	Nylon Lock Nut, 1/2 - 13	8
7	25-358	Decal, Smithco	1
8	78-390	Ball Lock Arm	1
9	HB-516-18-100	Hex Bolt, 5/16 - 18 x 1	1
	HNTL-516-18	Nylon Lock Nut, 5/16-18	1
10	HB-14-20-075	Hex Bolt, 1/4 - 20 x 3/4	1
	HNTL-14-20	Nylon Lock Nut, 1/4 - 20	1
11	HB-38-16-225	Hex Bolt, 3/8 - 16 x 2 1/4	1
	HW-38	Flat Washer, 3/8	1
	HNW-38-16	Wing Nut, 3/8 - 16	1
12	HB-38-16-225	Hex Bolt, 3/8 - 16 x 2 1/4	1
	HW-38	Flat Washer, 3/8	2
	HNTL-38-16	Nylon Lock Nut, 3/8 - 16	1
13	78-352	Control Panel Mount	1
14	HST-14-20-075	Truss Head Hex Bolt, 1/4 - 20 x 3/4	4
	HNFL-14-20	Flange Whiz-loc Nut, 1/4 - 20	4

INSTALLATION INSTRUCTIONS

Use two people to install hitch.

- Block both wheels so machine does not roll.
- Remove tires (Ref 6) from wheels on sweeper and mount on new wheels (Ref 7) supplied with kit. Block rear of machine up. Remove the rear tires and rear hubs. All parts except hubs to be reused.
- Put new wheel assembly back on and hold in place with the 1/2-20 lug nuts.
- Check all nuts and be sure they are tight.
- Use the jack that is part of the sweeper to raise or lower sweeper to comfortable working height.
- Slide the goose neck (Ref 2) under the sweeper frame. Use the eight 1/2 - 13 x 1 1/4 Hex Bolts (Ref 3) and Nylon Lock Nuts onto secure goose neck. Tighten all hardware.
- Install the control panel mount (Ref 1) on the front of the goose neck (Ref 2) as shown, using two 3/8 - 16 x 2 1/4 Hex Bolts (Ref 11 and 12). On the bottom Hex Bolt use Nylon Lock Nut (Ref 12) and just tighten snug. On the top Hex Bolt use the 3/8 washer and wing nut (Ref 11). Tighten both after adjusting for the proper position.
- The control panel has all hose, wiring and throttle cable connected to it and the sweeper. The control panel is wrapped and fastened to the front of the sweeper.
- Remove the control panel from the sweeper, bring it forward with the hoses to the rear and the throttle on the left hand side.
- Fasten the control panel to the control panel mount with the four Truss Head Hex Bolts 1/4 - 20 x 3/4 (Ref 13) and four Flange Whiz-loc Nuts. Tighten all hardware.
- Install 2" Ball in 5th Wheel Hitch of tow vehicle.



73-006 HAND HELD VACUUM HOSE PARTS LIST

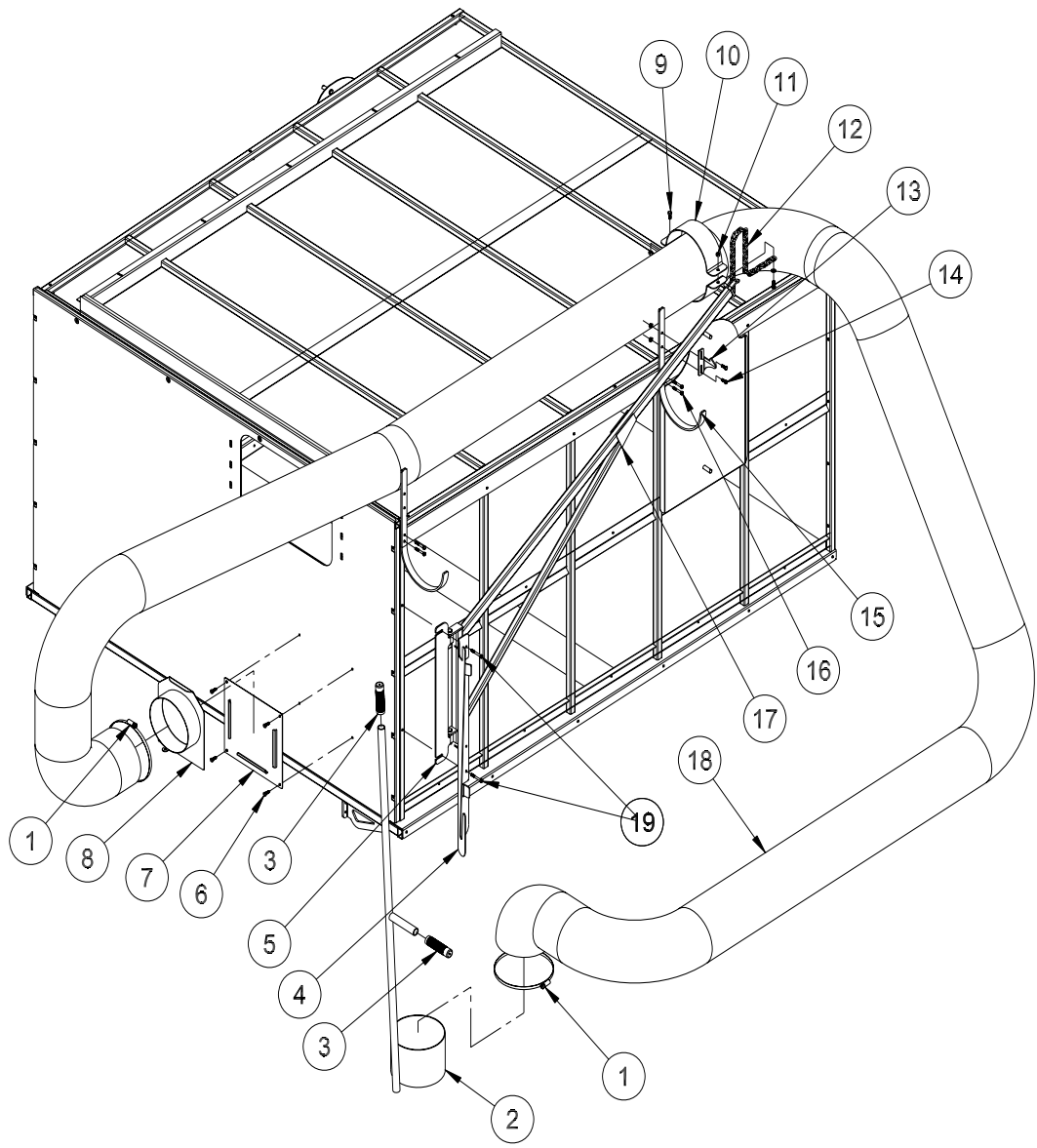

73-006 HAND HELD VACUUM HOSE PARTS LIST

REF#	PART#	DESCRIPTION	QUANTITY
1	18-340	Hose Clamp	2
2	78-354	Hose Handle	1
3	15-019	Round Grip	2
4	78-350	Handle Holder	1
	8803-17	Trim, Black	1
5	72-153	Boom Mounting Bracket	1
	HP-18-100	Cotter Pin, 1/8 x 1	2
	18-043	Flange Bushing (part of 72-153)	2
6	HB-14-20-075	Hex Bolt, 1/4 - 20 x 3/4	4
	HNFL-14-20	Flange Whiz-loc Nut, 1/4 - 20	4
7	72-141	Hose Plate	1
8	78-314	Remote Hose Connection	1
9	HB-516-18-075	Hex Bolt, 5/16 - 18 x 3/4	1
	HNFL-516-18	Flange Whiz-loc Nut, 5/16 - 18	1
10	72-154	Hose Clamp	2
11	HB-516-18-075	Hex Bolt, 5/16 - 18 x 3/4	1
	HW-516	Flat Washer, 5/16	1
	HNFL-516-18	Flange Whiz-loc Nut, 5/16 - 18	1
12	8820-25	Straight Link Chain, 25"	1
13	72-152	Latch Bracket	1
14	HSTP-14-20-075	Machine Screw, 1/4 - 20 x 3/4	2
	HNFL-14-20	Flange Whiz-loc Nut, 1/4 - 20	2
15	72-142	Hose Hanger	2
16	HB-14-20-175	Hex Bolt, 1/4 - 20 x 1 3/4	4
	HNFL-14-20	Flange Wkwhiz Nylon Lock Nut, 1/4 - 20	4
17	72-155	Vacuum Hose Boom	1
18	8970-300	Vacuum Hose	1
19	HB-14-20-200	Hex Bolt, 1/4 - 20 x 2	2
	HNFL-14-20	Flange Whiz-loc Nut, 1/4 - 20	2

(Continued on next page)

73-006 HAND HELD VACUUM HOSE DRAWING

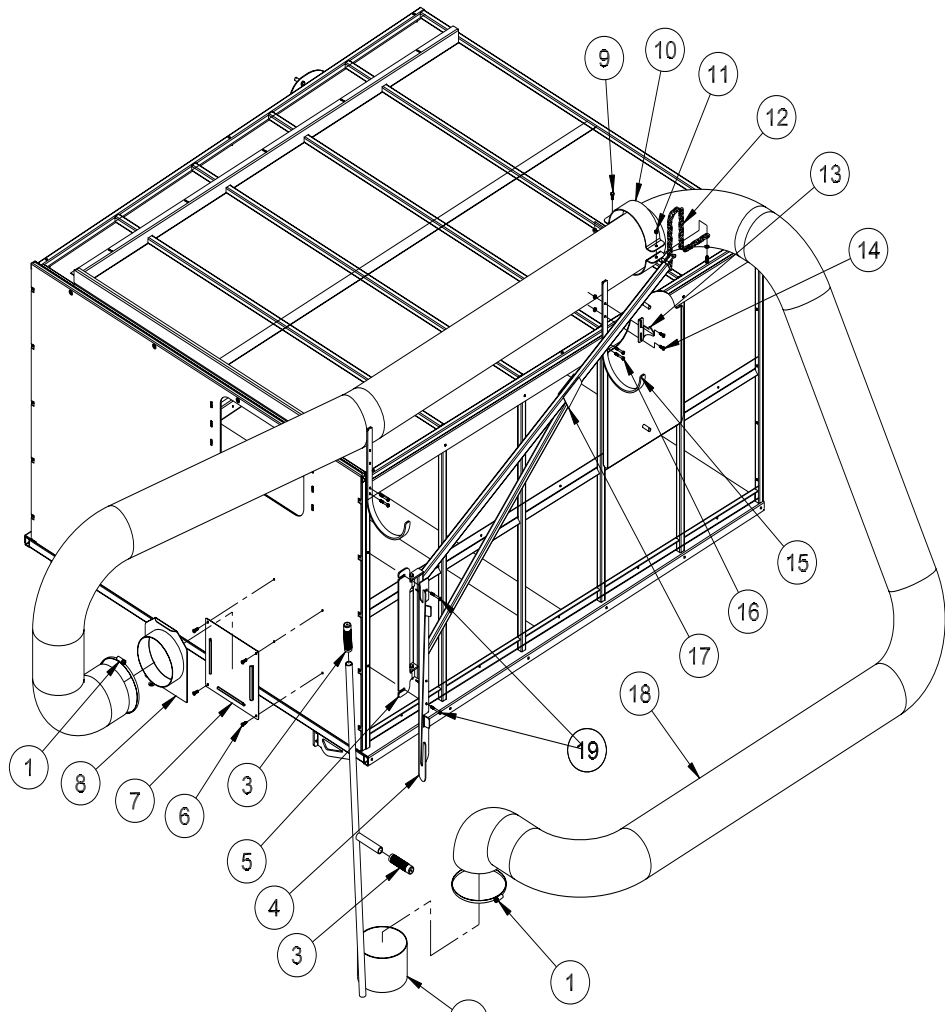

Accessories

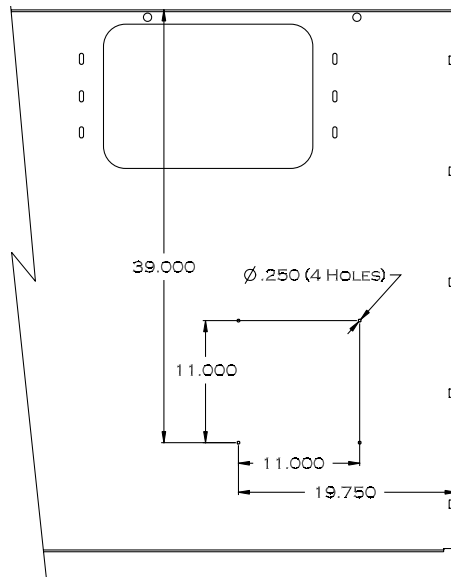
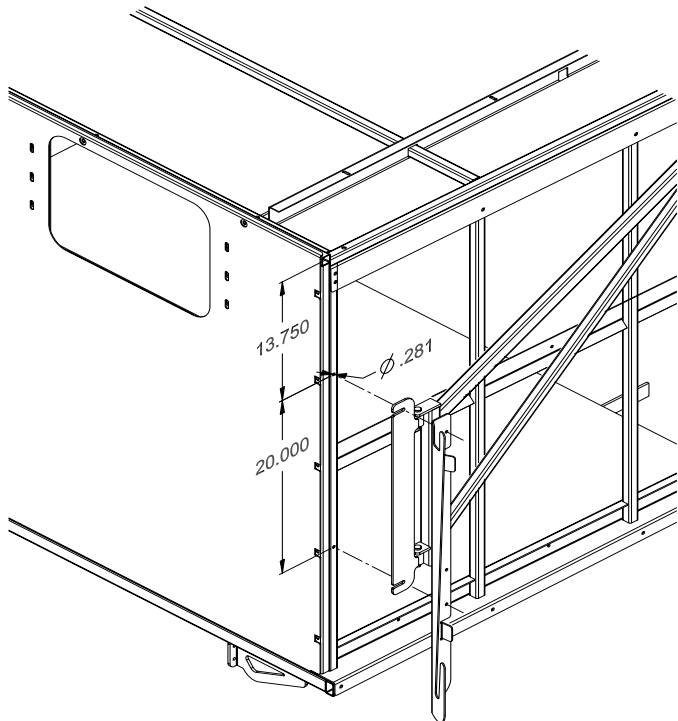

73-006 HAND HELD VACUUM HOSE PARTS LIST

You will need two people and the tailgate open with an empty hopper **and the machine not operating.**

Note: **Left** and **Right** sides are determined by standing and facing the rear of the machine.

1. Start by drilling four(4) $\frac{9}{32}$ holes in the front panel on the left side, under the hopper chute opening, as illustrated. Start with the top right hole at 28 inches down from the top and $8\frac{3}{4}$ inches in from the right, as illustrated in the drawing.
2. Drill the three remaining holes in a square pattern as illustrated in the drawing. De-burr holes and mount the Hose Plate(Ref 7) and secure with four(4) $\frac{1}{4}$ -20 x $\frac{3}{4}$ Hex Bolts and Flange Whiz-Nylon Lock Nuts.
3. To mount the Handle Holder(Ref 4) drill two(2) $\frac{9}{32}$ holes through the front vertical tube and hopper side panel on the Left Hand Hopper Side. Mark hole locations by measuring from the top of the hopper side, down $13\frac{3}{4}$ inches to the first hole and $33\frac{3}{4}$ inches to the second hole. Drill holes centered ($\frac{1}{2}$ ") from the side of the tube. Reference illustration to the left.
4. Install Boom Mount Bracket with Boom(Ref's 5 & 17) and Handle Holder(Ref 4) using two(2) $\frac{1}{4}$ -20 x $2\frac{3}{4}$ Hex Bolts and $\frac{1}{4}$ -20 Flange Whiz-Nylon Lock Nuts(Ref 19) in the holes drilled in the previous step. Mount parts (Ref's 5 & 4) loosely, do not tighten yet. Pull boom mount bracket outward in the slots and tighten Hex Bolts.
5. Mount one Hose Hanger(Ref 15) on the front of the hopper using the existing hardware. Tighten hardware.
5. To mount the second hose hanger, remove the drill screw in the upright to the front of hopper door arm plate. In the remaining screw hole, drill a $\frac{9}{32}$ hole completely through to the inside and de-burr. Mount the remaining Hose Hanger(Ref 15) using the lower hole of the hanger with one(1) $\frac{1}{4}$ - 20 x $1\frac{3}{4}$ Hex Bolt and Flange Whiz-Nylon Lock Nut(Ref 16). Position the hanger in the vertical position and drill another $\frac{9}{32}$ " hole using the second hole as a guide. Drill hole completely through to inside of hopper. De-burr and install the remaining Hex Bolt and nut.
6. Mount Latch Bracket(Ref 13) on the rear Hose Hanger(Ref 15) in the top holes using two(2) $\frac{1}{4}$ - 20 x $\frac{3}{4}$ Machine Screws and Flange Whiz-Nylon Lock Nuts(Ref 14). Tighten hardware.
7. Next, swing the Boom back alongside the hopper until it comes in contact with the Latch Bracket(Ref 13). Slide Latch Bracket up until it lifts the Boom $\frac{1}{8}$ ". Tighten the hardware(Ref 14) for the Latch Bracket and the hardware(Ref 19) for the Boom Mount Bracket.
8. Now connect the Hose(Ref 18) to the Hose Handle(Ref 2) in the position illustrated and secure with one Hose Clamp(Ref 1). Connect the other end of the hose to the Remote Hose Connector(Ref 8) and secure with the remaining Hose Clamp.
9. Hex Bolt Hose Clamps(Ref 10) together over the Hose(Ref 18), close to center. Use one(1) $\frac{5}{16}$ - 18 x $\frac{3}{4}$ Hex Bolt and Flange Whiz-Nylon Lock Nut(Ref 9) for one side. For the other side, use the remaining $\frac{5}{16}$ - 18 x $\frac{3}{4}$ Hex Bolt, $\frac{5}{16}$ Washer and Flange Whiz-Nylon Lock Nut(Ref 11) to connect the Chain(Ref 12). Place the Washer between the Hex Bolt and the Chain with the Hex Bolt going through the end link in the chain first, then through the clamp.
10. Slide the two round Grips(Ref 3) on to the Hose Handle.
11. For storage, place Remote Hose Connector(Ref 8) in Hose Plate(Ref 7) on the front panel. Drape hose over the top and go toward the back of machine, past the rear hose hanger bring hose to the side of machine and up into the Hose Hangers. At the front place the Hose Handle(Ref 2) into the Handle Holder(Ref 4).
12. To use the remote vacuum, remove the Cover Plate from either side of the vacuum housing and replace with the Remote Hose Connector(Ref 8). Store the Cover Plate in the Hose Plate(Ref 7). Before using the vacuum the lever on the left hand side of the vacuum housing must be pulled out and turned counterclockwise 90° and secured in the handle bracket with lynch pin.
13. You may want to remove the hose handle, hose and remote hose connector if you are not going to use the remote vacuum for an extended amount of time.

73-007 3-POINT HITCH FOR TRACTOR

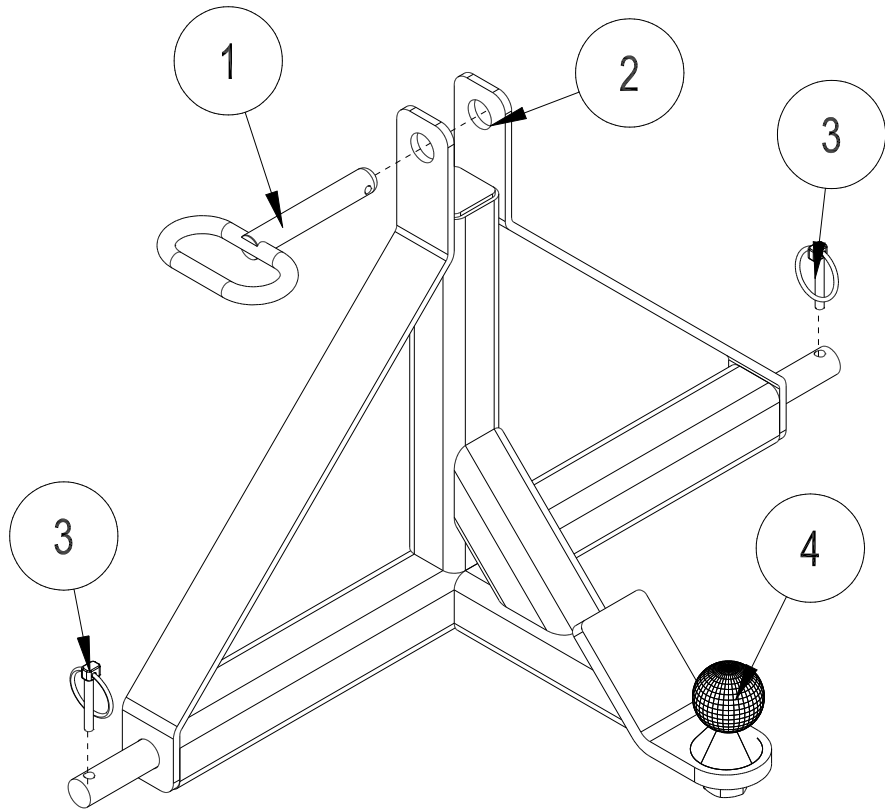

FOR USE WITH 35HP MINIMUM TRACTOR

REF#	PART#	DESCRIPTION	QUANTITY
1	7-029	Hitch Pin, $\frac{3}{4}$ x 4	1
2	73-039	3-Point Hitch	1
3	42-539	Lynch Pin	2
4	18-371	2" Ball	1

DECAL LIST

REF#	PART#	DESCRIPTION	QUANTITY
A	16-088	Decal, Moving Parts Hot	1
B	25-277	Decal, Battery Warning	1
C	25-298	Decal, Warning Hot	2
D	25-279	Decal, Safety Warning	1
E	25-286	Decal, Pinch Point	2
F	25-355	Decal, Tire Pressure 18 PSI	2
G	25-356	Decal, Tire Pressure 20 PSI	2
H	25-374	Decal, Smithco 12"	1
I	25-362	Decal, Danger Fire	1
	25-363	Decal, Max. Depth	1
	72-182	Decal, Max Load	1
J	25-376	Decal, 98 dBA	1
K	27-093	Decal, Hydraulic Oil	1
L	72-061	Decal, Big Vac (Small)	2
M	72-089	Decal, Hose Routing	1
N	73-034	Decal, V72E (large)	1
	72-047	Decal, Big Vac (Large)	1
O	75-651	Decal, Hopper Lift Safety	2
P	76-304	Decal, Crush Points	2
Q	76-305	Decal, Rotating Parts	2
R	76-307	Decal, Tower Warning	2
S	78-217	Decal, Control Panel	1
	78-438	Decal, Hang Tag Dumping	1
T	78-552	Decal, Open Close	1

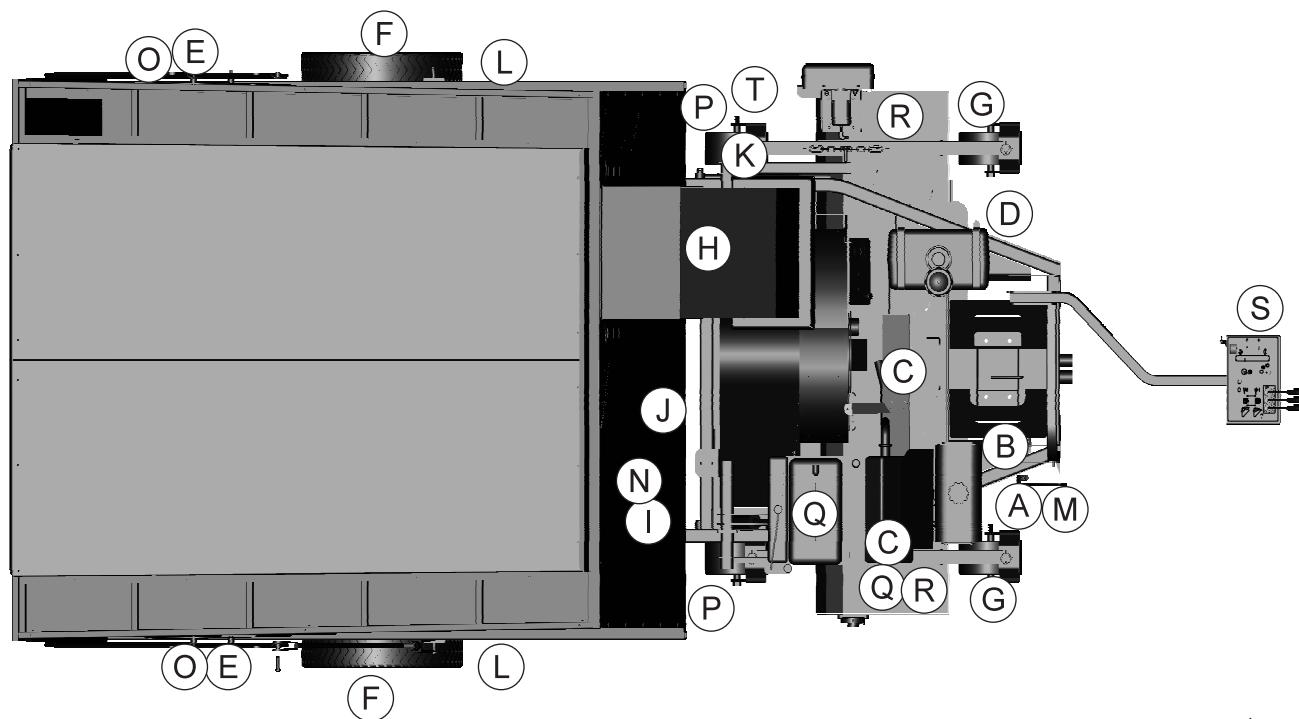

QUICK REFERENCE REPLACEMENT PARTS

REPLACEMENT FILTER

23-031	Hydraulic Oil Filter Element	
76-395-01	Air Cleaner Cartridge	Briggs # 841497
76-395-02	Safety Filter Cartridge	Briggs #8241497
76-487	Engine Oil Filter	Briggs #842921

REPLACEMENT BELTS

78-277	Belt 3V x 315 (finger reel) 3
--------	-------------------------------

SEAL KITS

78-416	Hydraulic Valve 3 Bank
10-187	Hydraulic Cylinder
14-273	Seal Kit
72-040	Hydraulic Cylinder
72-040-01	Seal Kit
72-040-02	Pin with Clips (2 per cylinder)
*72-199	Hydraulic Motor (finger reel)
72-199-01	Seal Kit
*78-413	Hydraulic Pump
78-413-01	Seal Kit
72-077	Hearing Protection
76-354	Fire Extinguisher

* NO OTHER PARTS ARE REPLACEABLE FOR HYDRAULIC MOTOR OR PUMP

HYDRAULIC FLUID

SAE 10W-40 API Service SJ or higher motor oil

The Smithco Commercial Products Two-Year Limited Warranty

Smithco, Inc. (Smithco) warrants your 2016 or newer Smithco Commercial Product ("Product") purchased after October 1, 2016 to be free from defects in materials or workmanship for the period of time listed below. Where a warrantable condition exists, Smithco will repair the Product at no cost to you including diagnosis, labor (at the Smithco standard labor rate, subject to the Smithco flat rate schedule), and parts.

Warranty Duration is:

- (1) Two years, 1500 operational hours* from the date of delivery to the original purchaser or Five years from the date of original manufacturer of the product, whichever occurs first. (*Products equipped with hour meter).
- (2) Products used in rental situations are covered for 90 days from date of delivery to original user/renter.

Owner Responsibilities:

As the Product owner, you are responsible for required maintenance and adjustments stated in your Owner's Manual. Failure to perform required maintenance and adjustments can be grounds for disallowing a warranty claim. **You are particularly responsible to train all present and future operators of this product on the safe operation of this product at your location.**

Instructions for Obtaining Warranty Service:

You are responsible for notifying the Authorized Smithco Products Distributor from whom you purchased the Product as soon as you believe a warrantable condition exists and not later than 30 days from discovery of the condition.

If you need help locating an Authorized Smithco Distributor, or if you have questions regarding your warranty rights or responsibilities, you may contact us at:

Smithco Product Support Department
200 West Poplar Ave.
Cameron, Wisconsin 54822
Telephone: 800-891-9435 E-Mail: ProductSupport@Smithco.com

Maintenance Parts:

Parts scheduled for replacement as required maintenance ("Maintenance Parts"), are warranted for the period of time up to the scheduled replacement time for that part.

Items/Conditions Not Covered:

Not all product failures or malfunctions that occur during the warranty period are defects in materials or workmanship. The items/conditions listed below are not covered by this warranty:



Product failures which result from the use of non-Smithco replacement parts, or from installation and use of add-on, modified, or unapproved accessories are not covered.



Product failures which result from failure to perform required maintenance and/or adjustments are not covered.



Product failures that result from operating the Product in an abusive, negligent or reckless manner are not covered.



This warranty does not apply to parts subject to consumption through use, unless found to be defective. Examples of parts which are consumed, or used up, during normal Product operation include, but are not limited to: blades, tines, teeth, scarifiers, rakes, plates, wear plates, castor wheels, tires, batteries, filters, belts, nozzles, etc.



This warranty does not apply to failures caused by outside influence. Items considered to be outside influence include, but are not limited to, weather, storage practices, contamination, use of unapproved coolants, lubricants, additives, or chemicals, etc.



This warranty does not apply to normal “wear and tear” items. Normal “Wear and Tear” includes, but is not limited to, damage to seats due to wear or abrasion, worn painted surfaces, scratched decals or windows, etc.



Smithco may require the return of failed parts or components in order to determine the validity of any warranty claim.



Smithco will not be obligated to replace components of other manufacturers if inspection by the original component manufacturer indicates that failure was due to normal wear and tear, expected consumption through use or improper care or service.

Other Legal Disclaimers:

The above remedy for product defects through repair or replacement by an authorized Smithco distributor or dealer is the purchaser’s sole remedy for any defect. This warranty gives you specific legal rights, and you may also have other rights which vary from state to state.

THERE ARE NO OTHER EXPRESS WARRANTIES OTHER THAN THOSE SET FORTH ABOVE. ALL IMPLIED WARRANTIES OF MERCHANTABILITY AND FITNESS FOR USE ARE LIMITED TO THE DURATION OF THE LIMITED WARRANTIES CONTAINED HEREIN.

Some states may not allow limitations on how long an implied warranty lasts, so the above limitation may not apply to you.

THE SMITHCO COMPANY IS NOT LIABLE FOR INDIRECT, INCIDENTAL OR CONSEQUENTIAL DAMAGES IN CONNECTION WITH THE USE OF THE PRODUCT, INCLUDING ANY COST OR EXPENSE OF PROVIDING A SUBSTITUTE PRODUCT OR SERVICE DURING PERIODS OF MALFUNCTION OR NON-USE.

Some states may not allow the exclusion of indirect, incidental or consequential damages, so the above exclusion may not apply to you.

Smithco neither assumes, nor authorizes any person to assume for it, any other liability in connection with the sale or use of this product.

