

Parts & Service



Spray Star 1200

Truck Model 20-500-C

Manual System 1201
TeeJet Radion® 8140 1202
TeeJet® 744 1204
TeeJet Aeros/DynaJet® 1215/1218/1220
TeeJet Radion/DynaJet® 1207/1208

SN: 12021

Product Support:

Hwy 55 & Poplar Ave; Cameron WI 54822

1-800-891-9435 productsupport@smithco.com

CONTENTS

Introduction.....1-3

Introduction.....	1
General Safe Practices.....	2
Specifications	3
Optional Spray Equipment.....	3

Service.....4-9

Maintenance.....	4-6
Storage.....	6
Service Chart.....	7
End User's Service Chart.....	8
Adjustments.....	9

Diagrams10-13

Wiring Diagram.....	10-11
Hydraulic Diagram.....	12-13

Parts.....14-59

Body & Frame	14-15
Engine Cover/ Roll Bat	16-17
Control Panel and Steering	18-19
Foot Pedal Linkage.....	20-21
Front Axle	22-23
Oil Tank and Fuel Tank	24-25
Seat Panel.....	26-27
Hydraulic Pump.....	28-29
Engine and Exhaust	30-31
Spray Pump.....	32-33
Spray Tank.....	34-35
Turbo Quad Agitator	36-37
Park Brake and Rear Axle	38-39
15-301 Orbital	40-41
76-638 Hydrostatic Pump.....	42-43
76-638 Pump Maintenance	44-54
76-197 Eaton Gear Pump.....	55
76-197 Pump Maintenance	56-57
15-970 Hypro® Pump	58-59

Spray Systems.....60-110

Plumbing 1201 Manual System.....	60-61
Plumbing 1202 System (Radion® 8140)	62-65
Plumbing 1204 System (TeeJet® 744)	66-69
1202 Wiring System(Radion® 8140)	70
1204 Wiring System (TeeJet® 744)	71
Control Mounts	72-73
Plumbing 1207/1208/1215/1218/1220	74-75
1207/1208 DynaJet Wiring	76
1207/1208 Rear Module Mounts	77
1215/1218/1220 Aeros Wiring	78
1215/1218/1220 DynaJet Wiring	79
1215/1218/1220 Rear Module Mounts	80
14-801/14-607 Strainer.....	81
15-737/14-628 Flanged Strainer.....	82
15-743 Manifold Ball Valve	83
20-817 Regulaotr Valve	84
20-785 Regulator Valve	85
17-580 20' HD Boom	86-89
17-580 20' HD Boom 1202/1204 Plumbing	90
17-580 20' HD Boom 1207 Plumbing	91
17-580 20' HD Boom 1220 Plumbing	92
17-585 18' HD Boom 1218 Plumbing	93
17-585 18' HD Boom	94-97
17-585 18' HD 1202/1204 Plumbing	98
17-585 18' HD Boom 1208 Plumbing	99
17-601 15' HD Boom	100-103
17-601 15' HD Boom 1202/1204 Plumbing	104
17-601 15' HD Boom 1215 Plumbing	105
Boom Hinge.....	106
Standard Nozzle Assembly.....	107
1207/1208 Nozzle Assembly	108-109
1215/1218/1220 Nozzle Assembly	110

Accessories 111-136

15-835 Tank Rinsing System.....	111
16-906 Electric Hose Reel	112-113
Electric Hose Reel Wiring Diagram	114
Hose Reel Adjustments	115
16-129 Manual Hose Reel	116
15-967 Hose Reel for HD Booms	117
Hose Reel Plumbing.....	118-119
15-965 Foam Marker Installation.....	120-123
14-291 Foam Marker Parts List.....	124-125
Foam Marker Wiring	126
20-815 Water Meter Kit (Gallons).....	127
20-816 Water Meter Kit (Liters)	127
15-968 20 Gallon Rinse Tank	128-129
30-006 Fresh Water Tank - Rear Mount	130
10-653 Fresh Water Tank - Front Mount.....	131
15-619 Chemical Clean-load System.....	132-136

Reference137-138

Decal List.....	137
Quick Reference Replacement Parts	138
Limited Warranty Limited Warranty	

Thank you for purchasing a **Smithco** product.

Read this manual and all other manuals pertaining to the Spray Star 1200 carefully as they have safety, operating, assembly and maintenance instructions. Failure to do so could result in personal injury or equipment damage.

Keep manuals in a safe place after operator and maintenance personnel have read them. Right and left sides are from the operator's seat, facing forward.

 **WARNING:**

Engine exhaust and some of its constituents are known to the State of California to cause cancer, birth defects, and other reproductive harm.
For more information visit www.P65Warning.ca.gov

WARNING

Failure to follow cautious operating practices can result in serious injury to the operator or other persons. The owner must understand these instructions, and must allow only trained persons who understand these instructions to operate this vehicle.

All **Smithco** machines have a Serial Number and Model Number. Both numbers are needed when ordering parts. The serial number plate on the Spray Star 1200 is located on right mainframe behind exhaust. Refer to engine manual for placement of engine serial number.

For product and accessory information, help finding a dealer, or to register your product please contact us at www.Smithco.com.

Information needed when ordering replacement parts:

1. Model Number of machine
2. Serial Number of machine
3. Name and Part Number of part
4. Quantity of parts

For easy access record your Serial and Model numbers here.

SMITHCO WAYNE, PENNSYLVANIA 19087 USA 610-688-4009 Fax 610-688-6069			
SERIAL NO.	kW/hp	DATE OF MFG.	
<input type="text"/>	<input type="text"/>	<input type="text"/>	
MODEL NO.	lb/kg Empty	lb/kg Full	
<input type="text"/>	<input type="text"/>	<input type="text"/>	

SMITHCO CUSTOMER SERVICE 1-800-891-9435

SAFE PRACTICES

1. It is your responsibility to read this manual and all publications associated with this machine.
2. Never allow anyone to operate or service the machine or its optional equipment without proper training and instructions. Never allow minors to operate any equipment.
3. Learn the proper use of the machine, the location and purpose of all the controls and gauges before you operate the equipment. Working with unfamiliar equipment can lead to accidents.
4. Wear all the necessary protective clothing and personal safety devices to protect your head, eyes, ears, hands and feet. Operate the machine only in daylight or in good artificial light.
5. Inspect the area where the equipment will be used. Pick up all debris you can find before operating. Beware of overhead obstructions and underground obstacles. Stay alert for hidden hazards.
6. Never operate equipment that is not in perfect working order or without decals, guards, shields, or other protective devices in place.
7. Never disconnect or bypass any switch.
8. Carbon monoxide in the exhaust fumes can be fatal when inhaled, never operate a machine without proper ventilation.
9. Fuel is highly flammable, handle with care.
10. Keep engine clean. Allow the engine to cool before storing and always remove the ignition key.
11. Disengage all drives and set park brake before starting the engine.
12. Never use your hands to search for oil leaks. Hydraulic fluid under pressure can penetrate the skin and cause serious injury.
13. This machine demands your attention. To prevent loss of control or tipping of the vehicle:
 - A. Use extra caution in backing up the vehicle. Ensure area is clear.
 - B. Do not stop or start suddenly on any slope.
 - C. Reduce speed on slopes and in sharp turns. Use caution when changing directions on slopes.
 - D. Stay alert for holes in the terrain and other hidden hazards.
14. Before leaving operator's position:
 - A. Disengage all drives.
 - B. Set park brake.
 - C. Shut engine off and remove the ignition key.
 - D. If engine has to run to perform any maintenance keep hands, feet, clothing and all other parts of body away from moving parts.
15. Keep hands, feet and clothing away from moving parts. Wait for all movement to stop before you clean, adjust or service the machine.
16. Keep the area of operation clear of all bystanders.
17. Never carry passengers.
18. Stop engine before making repairs/adjustments or checking/adding oil to the crankcase.
19. Use parts and materials supplied by **Smithco** only. Do not modify any function or part.
20. Use caution when booms are down as they extend out beyond the center line of the machine.
21. The tank is a confined space, take precaution.

These machines are intended for professional maintenance on golf courses, sports turf, and any other area maintained turf and related trails, paths and lots. No guaranty as to the suitability for any task is expressed or implied.

SPECIFICATIONS SPRAY STAR 1200

WEIGHTS AND DIMENSIONS

Length	120" (305 cm)
Width	65" (165 cm)
Width With 18' Boom Open	240" (610 cm)
Height w/ Roll Bar	77" (195 cm)
Height w/ 18' Booms Folded	110" (279 cm)
Wheel Base	68" (173 cm)
Weight Empty	1877 lbs (851 kg)
Weight Full	3626 lbs (1645 kg)

SOUND LEVEL (DBA)

At ear level	92 dBA
At 3 ft. (0.914 m)	98 dBA
At 30 ft. (9.14 m)	88 dBA

ENGINE

Make	Briggs & Stratton
Model#	613477
Type / Spec#	0271-J1
Horsepower	35 hp (26 kW)
Fuel	Unleaded 87 Octane Gasoline Minimum
Cooling System	Air Cooled
Lubrication System	Full Pressure
Alternator	20 Amp

WHEELS & TIRE

Front: Two 20 x 10.00 x 10 NHS Multi-Rib; 20 psi (1.4 bar)
Rear: Two 24 x 13.00 x 12 NHS Multi-Trac; 20 psi (1.4 bar)

SPEED

Infinitely Variable 0-12 m.p.h. (0-20 kph)

BATTERY

	Automotive type 24F - 12 volt
BCI Group	Size 24
Cold Cranking Amps	900 minimum
Ground Terminal Polarity	Negative (-)
Maximum Length	10.25" (26 cm)
Maximum Width	6.88" (17 cm)
Maximum Height	10" (25 cm)

FLUID CAPACITY

Crankcase Oil	See Engine Manual
Fuel	10 gallon (45.46 liters)
Hydraulic Fluid	5 gallon (19 liters)
Grade of Hydraulic Fluid	SAE 10W-40 API Service SJ or higher Motor Oil

OPTIONAL EQUIPMENT

20-816	Water Meter Kit (Liters)	20-815	Water Meter Kit (Gallons)
15-619	Chemical Clean-load	10-653	Fresh Water Wash Tank- Front Mount
15-622	Canopy	30-006	Fresh Water Wash Tank - Rear Mount
15-965	Foam Marker	15-968	26 Gal. Wash System with Electric Pump
17-601	15' HD Boom	17-585	18' HD Boom
17-580	20' HD Boom	17-622	Boom Shield for 17-585
15-967	Hose Reel Mount Kit	17-590	Sonic Boom
15-835	Tank Rinsing System		
16-129	Manual Rewind Hose Reel, 200-foot/61-meter capacity		
16-906	Electric Rewind Hose Reel, 200-foot/61-meter capacity		



MAINTENANCE

CAUTION

Before servicing or making adjustments to machine, stop engine and remove key from ignition.

IMPORTANT

Use all procedures and parts prescribed by the manufacturer's. Read the engine manual before operation.

LUBRICATION

Use No. 2 General purpose lithium base grease and lubricate every 100 hours. The Spray Star 1200 has 7 lube points.

- One on the rod end of hydraulic cylinder.
- One on each the right and left spindles.
- One on the reverse pedal.
- One on each end of tie rod.
- One on the forward pedal.

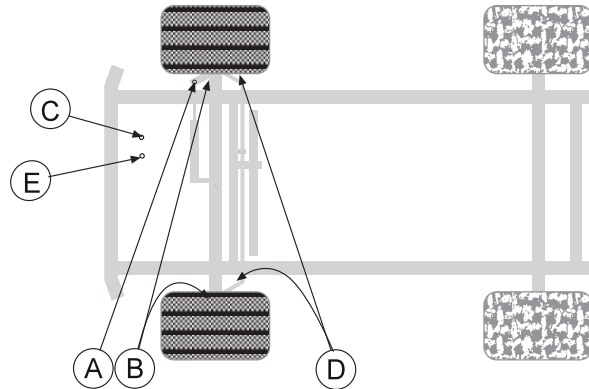

ELECTRICAL CONNECTIONS

Use dielectric grease on all electrical connections.

AIR CLEANER ON ENGINE

- Unclip the two clips, remove the cover and pull out the element.
- To service, clean by tapping gently on flat surface. Do not oil. Replace if very dirty or damaged.
- Clean out the inside of the body and cover.
- Place the element into the body and put the cover back on..

IMPORTANT

Do not use petroleum solvents, e.g., kerosene, which will cause cartridge to deteriorate. Do not use pressurized air to clean cartridge. Pressurized air can damage cartridge.

Cyclonic air cleaner 76-395-04

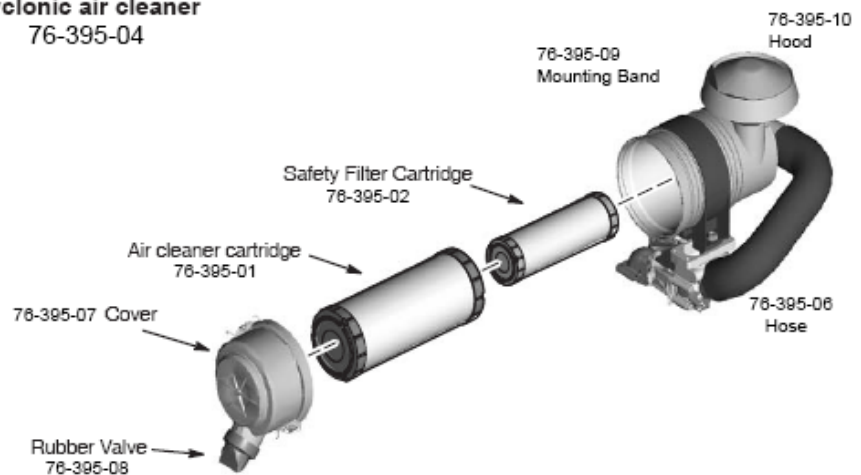

ENGINE OIL

Change and add oil according to chart below based on air temperature at the time of operation. Do not overfill. Use a high-quality detergent oil classified for service SF, SG, SH, SJ or higher. Use no special additives with recommended oils. Do not mix oil with gasoline.

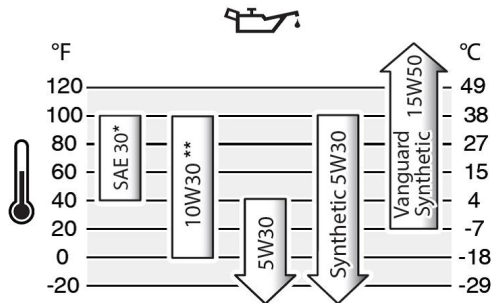

SAE Viscosity Grades

A quick twist and pull motion to open, push to close. Allows a quick and easy way to change oil without the mess



Engine Oil Drain Valve

HYDRAULIC OIL

1. Use SAE 10W-30 API Service SJ or higher motor oil.
2. For proper warranty, change oil every 500 hours or annually, which ever is first.
3. Oil level should be 2-2½" (5-6.4cm) from top of the tank when fluid is cold. Do not overfill.
4. After changing oil, run the machine for a few minutes. Check oil level and for leaks.
5. Always use extreme caution when filling hydraulic oil tank or checking level to keep system free of contaminants. Check and service more frequently when operating in extremely cold, hot or dusty conditions.
6. If the natural color of the fluid has become black or smells burnt, it is possible that an overheating problem exists.
7. If fluid becomes milky, water contamination may be a problem.
8. If either of the above conditions happen, change oil immediately after fluid is cool and find the cause. Take fluid level readings when the system is cold.
9. In extreme temperatures you can use straight weight oil. We recommend SAE 30W API Service SG when hot (above 90°F (33°C)) and SAE 10W API Service SJ or higher when cold (below 32°F (0°C) ambient temperature. Use either motor oil or hydraulic oil, but do not mix.
10. Oil being added to the system must be the same as what is already in the tank. Mark the tank fill area as to which type you put in.

TIRE PRESSURE

Caution must be used when inflating a low tire to recommended pressure. Over inflating can cause tires to explode. All tires should be 20 psi (1.4bar). Improper inflation will reduce tire life considerably.

WHEEL MOUNTING PROCEDURE

1. Set park brake. Turn machine off and remove key.
2. Block wheel on opposite corner.
3. Loosen nuts slightly on wheel to be removed.
4. Jack up machine being careful not to damage underside of machine.
5. Place wheel on hub lining up bolt holes.
6. Torque to 64-74 ft/lb (87-100Nm) using a cross pattern. Re-torque after first 10 hours and every 200 hours thereafter.
7. Lower machine to ground and remove blocks and jack.

MAINTENANCE

BATTERY

Batteries normally produce explosive gases which can cause personal injury. Do not allow flames, sparks or any ignited object to come near the battery. When charging or working near battery, always shield your eyes and always provide proper ventilation.

Battery cable should be disconnected before using "Fast Charge."

Charge battery at 15 amps for 10 minutes or 7 amps for 30 minutes. Do not exceed the recommended charging rate. If electrolyte starts boiling over, decrease charging.

Always remove grounded (-) battery clamp first and replace it last. Avoid hazards by:

1. Filling batteries in well-ventilated areas.
2. Wear eye protection and rubber gloves.
3. Avoid breathing fumes when electrolyte is added.
4. Avoid spilling or dripping electrolyte.

⚠ WARNING

Battery Electrolyte is an acidic solution and should be handled with care. If electrolyte is splashed on any part of your body, flush all contact areas immediately with liberal amounts of water. Get medical attention immediately.

⚠ WARNING

Use of booster battery and jumper cables. Particular care should be used when connecting a booster battery. Use proper polarity in order to prevent sparks.

TO JUMP START (NEGATIVE GROUNDED BATTERY):

1. Shield eyes.
2. Connect ends of one cable to positive (+) terminals of each battery, first (A) then (B).
3. Connect one end of other cable to negative (-) terminal of "good" battery (C).
4. Connect other end of cable (D) to engine block on unit being started (NOT to negative (-) terminal of battery)

To prevent damage to other electrical components on unit being started, make certain that engine is at idle speed before disconnecting jumper cables.

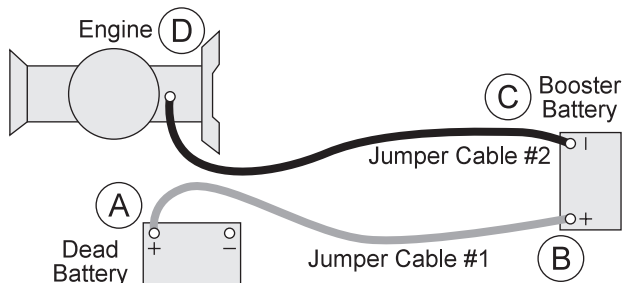

STORAGE

If the engine will be out of service for two or more months, use the following storage procedure.

1. Clean the exterior surfaces of the engine.
2. Change the oil and filter while the engine is still warm from operation.
3. The fuel system must be completely emptied, or the gasoline must be treated with a stabilizer to prevent deterioration.

If you choose to use a stabilizer, follow manufacturers recommendations, and add the correct amount for the capacity of fuel system. Fill fuel tank with clean, fresh gasoline. Run engine for 2-3 minutes to get stabilized fuel into carburetor. Close fuel shut-off valve when unit is being stored or transported.

To empty the system, drain fuel tank and carburetor, or run engine until tank and system are empty.

4. Remove the spark plugs. Add one tablespoon of engine oil into each spark plug hole. Install plugs, but do not connect the plug leads. Crank the engine two or three revolutions.
5. Store machine in a clean, dry place.

⚠ CAUTION

Before servicing or making adjustments to the machine, stop engine, set park break, block wheels and remove key from ignition.

⚠ IMPORTANT

Follow all procedures and **ONLY** use parts prescribed by the manufacturer. Read the engine manual before maintenance.

The suggested maintenance checklist is not offered as a replacement for the manufacturer's engine manual but as a supplement. You must adhere to the guidelines established by the manufacturer for warranty coverage. In adverse conditions such as dirt, mud or extreme temperatures, maintenance should be more frequent.

Maintenance Service Interval	Maintenance Procedure
After the first 8 operating hours	Torque the wheel lug nuts. (64-74 ft/lb (87-100 Nm)) Change the engine oil filter.
Before each use daily	Check the engine oil level. Clean area around muffler and controls. Check the hydraulic fluid level. Check the tire pressure. Check condition of hydraulic hoses and fittings. Inspect and clean the machine.
After the first 50 hours	Change Hydraulic Oil Filter.
Every 100 hours	Clean or change air filter. ^{1&2} Clean pre-cleaner. ¹ Change engine oil and filter. Replace spark plug . Lubricate machine. Clean or change remote air cleaner. Check the battery fluid level and cable connections.. Service exhaust system. Check belt tension .
Every 250 hours	Check engine valve clearance and adjust if necessary. Check idle speed. Clean battery terminals. Change hydraulic oil filter. Torque the wheel lug nuts. (64-74 ft/lb (87-100 Nm))
Every 500 hours or yearly	Change fuel filter. Change hydraulic oil and filter. Clean oil cooler fins. ¹ Replace air filter ² Replace fuel filter Clean air cooling system. ¹ Check safety filter in remote air cleaner.

¹ In dusty conditions or when airborne debris is present, clean more often.

² Every third air filter change, replace the inner safety filter.

WHEEL CREEP

"Creep" is when the engine is running and hydrostatic transmission is in neutral, but due to inadequate alignment, wheels still move. Do the following procedure to stop this motion.

1. Lift up and support machine so rear wheels are off the ground and can turn freely.
2. In the engine compartment, the hydrostatic transmission is on the left side. The shift arm (D) is under the pump and comes out the side. The idler arm (B) has a bearing that runs in the notch of the shift arm. Loosen bolt (A).
3. With engine running, move bearing (B) so it centers on the shift arm (D) and 'wheel creep' stops.
4. Tighten all fasteners and test by using foot pedal linkage to see that 'creep' is removed.
5. Turn engine off and lower machine.

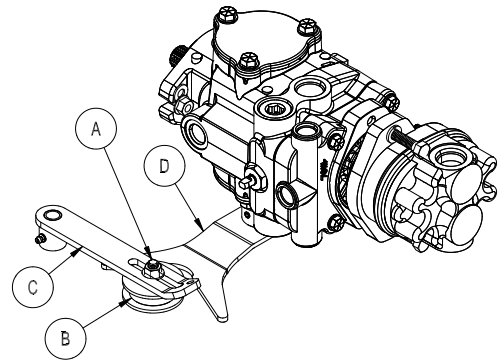

SPRAY PUMP WITH BELT

Located below the engine. The belt should have approximately $\frac{1}{2}$ " (13mm) of deflection in the center of the top strand. Loosen and tighten the $\frac{5}{16}$ "-18 x $1\frac{1}{4}$ " set screw located on the foot of the pump mount.

PARK BRAKE

Turn knob clockwise on end of park brake to tighten. Turn it counter clockwise to loosen. If finer adjustment is needed turn clevis on brake cable to adjust length of cable.

MASTER BOOM SWITCH (FOOT SWITCH)

The master boom switch, located on the left floorboard is used to override the master switch on the computer console of the spray systems. By pushing down it will turn on/off the booms.

GROUND SPEED CONTROL (FOOT SWITCH)

The ground speed control does not work the same as an automotive type cruise. The ground speed control is located on the left floorboard and is used to lock forward speed.

TO ENGAGE:

1. Flip rocker switch 'On' (green light).
2. Obtain desired speed with foot pedal.
3. Step on foot switch to lock speed.
4. Push foot switch again to disengage.

SPRAY BOSS CONTROL - ORANGE

Engages and disengages speed boss. Forward is engage and all the way back is disengage. When the lever is engaged it sets a stop for the accelerator. The accelerator pedal must be used to maintain this speed. To adjust speed use the knob on the end of the lever, counter clockwise increases speed and clockwise decreases speed. Disengage the lever and you will have full accelerator pedal range.

WIRING DIAGRAM

Diagrams

Color Code Chart

BI	Blue
Br	Brown
Y	Yellow
G	Green
O	Orange
R	Red
B	Black
GY	Gray
W	White

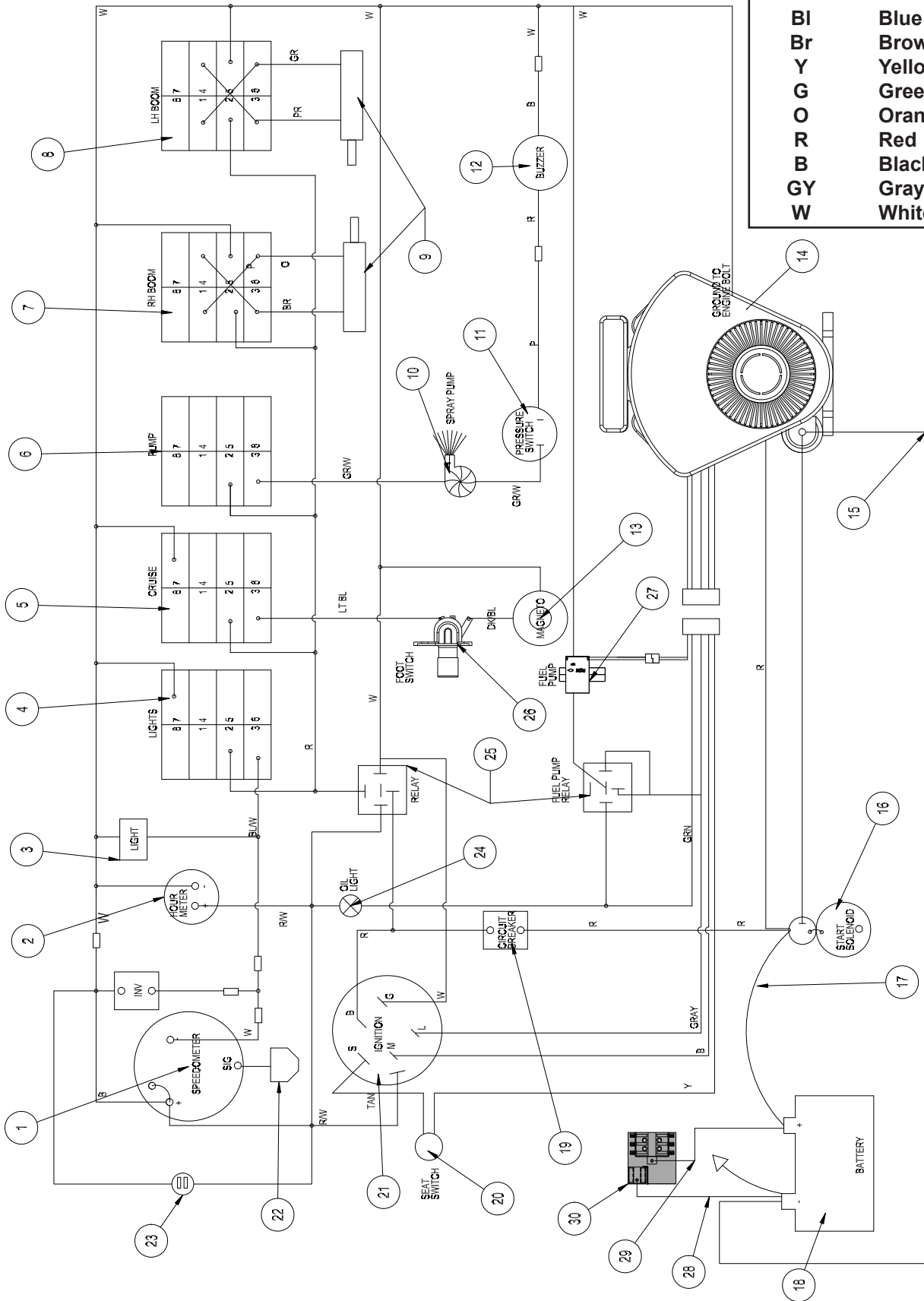

WIRING PARTS LIST

REF#	PART#	DESCRIPTION	QUANTITY
1	30-356	GPS Speedometer	1
2	12-804	Hour Meter	1
3	10-732	LED Light	1
4	Lights		
	15-782	Non-Lighted Switch, On-None-Off	1
	15-727	Rocker - No light	1
5	Cruise		
	15-726	Lighted Switch	1
	15-732	Rocker - Green	1
6	Pump		
	15-726	Lighted Switch	1
	15-731	Rocker - Amber	1
7	Left Boom		
	15-727	Rocker - No light	1
	15-728	Centering Switch, Momentary, On-Off-On	1
8	Right Boom		
	15-728	Centering Switch, Momentary, On-Off-On	1
	15-727	Rocker - No light	1
9	30-214	Boom Actuator	2
10	15-970	Spray Pump	1
11	33-480	Pressure Switch	1
12	77-207	Buzzer	1
	8874	Female Bullet	1
	8875	Male Bullet	2
	8963	Heat Shrink	2
13	33-084	Magnetic Coil	1
14	76-636	Briggs & Stratton 35 HP Engine	1
15	76-327	Negative Battery Cable	1
16		Solenoid	1
17	75-518	Red Battery Cable	1
18	33-216	Battery	1
19	77-261	40 Amp Circuit Breaker	1
	8977	Red Circuit Breaker Boot	1
	20-733	10AMP Circuit Breaker	1
	8877	Red Circuit Breaker Boot	1
20	14-292	Seat Switch	1
21	13-488	Key Switch	1
22	20-730-01	GPS Antenna (part of speedometer)	1
23	32-576	USB	1
24	50-359	Oil Temperature Light	1
25	30-042-06	Relay	2
26	33-509	Master Boom Switch	1
27	76-471	Electric Fuel Pump	1
28	8931-20	10GA White Wire	1
	8928	⁵ / ₁₆ Ring Terminal	1
	8912	³ / ₁₆ Ring Terminal	1
	8963	Heat Shrink	2
29	8919-26	10GA Red Wire	1
	8928	⁵ / ₁₆ Ring Terminal	1
	8912	³ / ₁₆ Ring Terminal	1
	8963	Heat Shrink	2
30	33-271	Fuse Panel	1
	15-941	Wire Harness	1

Use dielectric grease on all electrical connections.

HYDRAULIC DIAGRAM

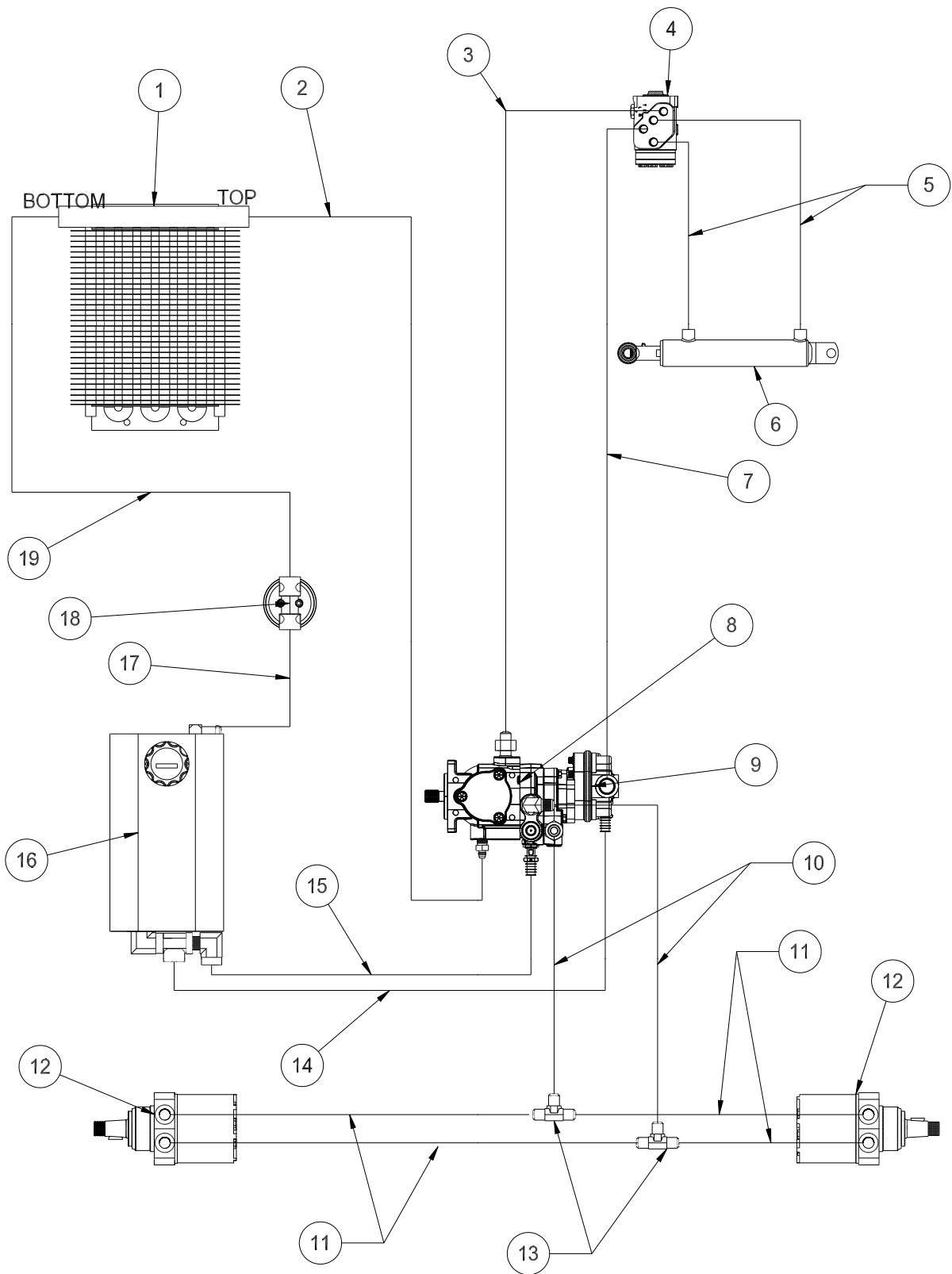

Diagrams

HYDRAULIC DIAGRAM PARTS LIST

REF#	PART#	DESCRIPTION	QUANTITY
1	15-624	Cooler	1
2	15-947	Hydraulic Hose, 34"	1
3	15-946	Hydraulic Hose, 74"	1
4	15-301	Orbital	1
5	10-671	Hydraulic Hose, 65"	2
6	15-839	Hydraulic Cylinder	1
	15-839-01	Seal Kit	1
7	15-945	Hydraulic Hose, 76.5"	1
8	76-638	Hydrostatic Pump	1
9	76-197	Gear Pump	1
10	15-682	Hydraulic Hose, 46 ³ / ₄ "	2
11	20-656	Tube Assembly	4
12	76-238	Wheel Motor	2
13	34-057	Tee	2
14	8832-30	³ / ₄ " Suction Hose x 30"	1
	18-040	Hose Clamp	2
15	8832-29	³ / ₄ " Suction Hose x 29"	1
	18-040	Hose Clamp	2
16	60-473	Hydraulic Oil tank	1
17	8917-16	³ / ₈ " Suction Hose x 16"	1
	18-040	Hose Clamp	2
18	26-016	Oil Filter	1
	23-031	Replacement Filter	1
19	15-948	Hydraulic Hose, 16.5"	1

PUMP DISPLACEMENT

76-638 Hydrostatic Pump

Displacement	Variable to 1.44 in ³ /R (23.6 cm ³ /R) 22.44 gpm (84.94 lpm) at 3600 rpm
Max Operating Speed	3600 rpm
Rated Pressure	3000 psi (206.8 bar)
Max Pressure	5000 psi (344.7 bar)
Max Inlet Vacuum	6 in Hg (.203 bar)
Max Inlet Temperature	225°F (107°C)
Max Allowable Case Pressure	25 psi (1.72 bar)

76-197 Gear Pump

Displacement	.40 in ³ /R (6.6 cm ³ /R) 6.23 gpm (25.39 lpm)
--------------	--

⚠ CAUTION

Over tightened fittings will result in crushing the cone which will create a leak.

MAIN DRAWING

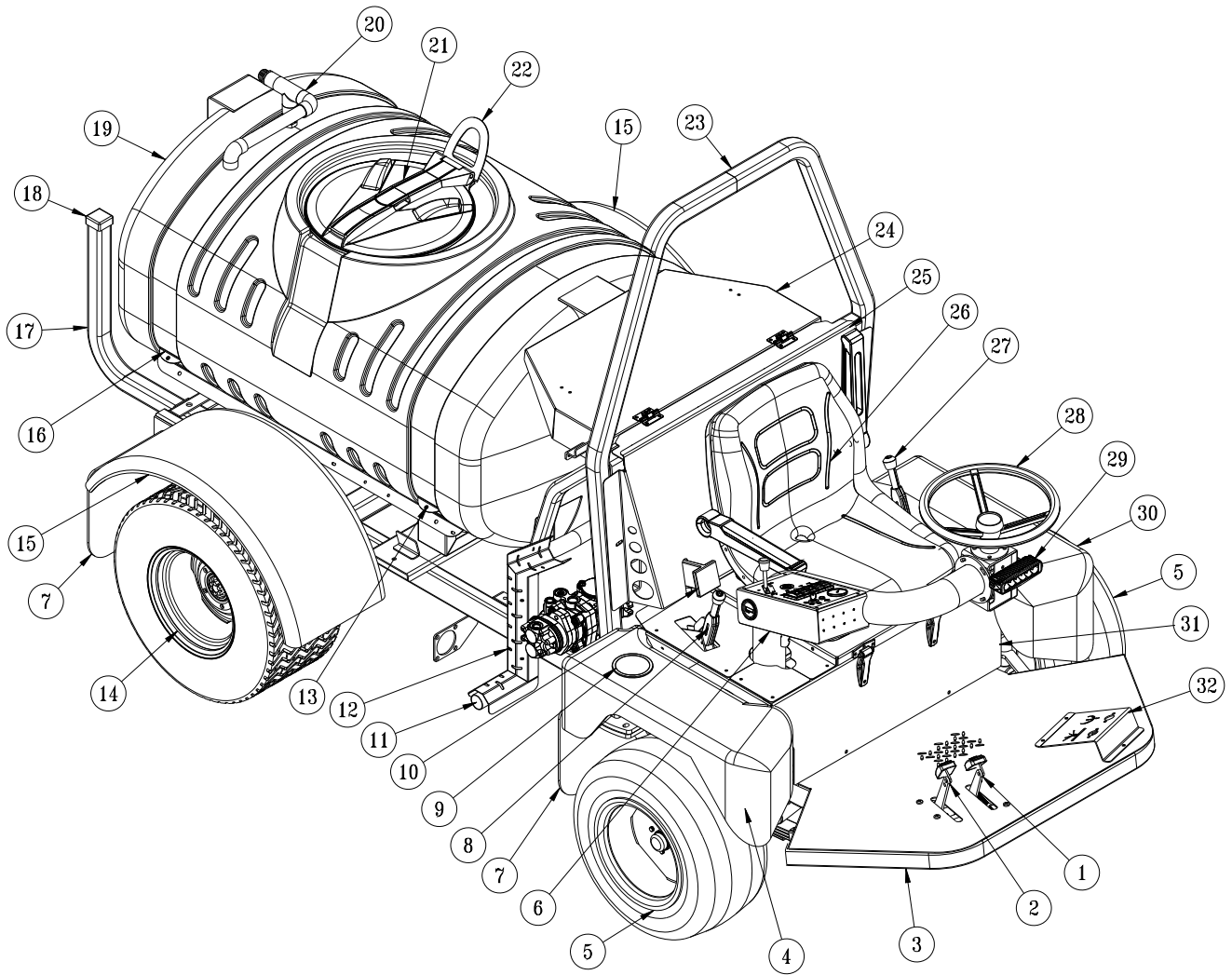

Parts

BODY & FRAME PARTS LIST

REF#	PART#	DESCRIPTION	QUANTITY
1	10-678	Reverse Pedal	1
2	10-677	Forward Pedal	1
3	15-925	Main Frame	1
4	10-663	RH Front Fender	1
5	16-857	Front Tire and Wheel	2
	16-857-01	Tire, 20 x 10.00 - 10NHS 4 Ply	2
	42-161-02	Wheel	2
6	10-683	Side Control Arm	1
	10-684	Control Panel	1
7	20-659	Mud Flap	4
8	60-106	Park Brake Handle	1
9	15-781	Drink Cup Holder	1
10	76-198-03	Seat Belt	1
11	15-963	Tailpipe	1
12	15-962	Tailpipe Guard	1
13	20-812	Front Tank Strap	1
14	16-225	Rear Tire and Wheel	2
	16-225-01	Tire, 24 x 13.00 - 12NHS 4 Ply	2
	16-225-02	Wheel	2
15	10-168	Rear Fender	2
16	20-811	Rear Tank Strap	1
17	17-615	Boom Support Tube	2
18	16-557	Square Cap	2
19	20-802	200 Gallon Spray Tank	1
	16-169	Strainer Basket	1
20	15-964	Air Gap Filler	1
21	16-953	Lid	1
	16-953-01	Gasket for Lid	1
22	10-639	Lid Stop	1
23	15-922	Roll Bar	1
24	15-936	Engine Hood	1
25	15-934	Back Panel	1
26	14-294	Seat kit	1
	10-706	Arm Rests	1
27	10-120	Speed Boss Handle	1
28	20-057	Steering Wheel	1
	20-129	Center Steering Wheel Cap	1
29	10-732	LED Head Light	1
30	10-662	LH Front Fender	1
31	10-680	Seat Frame	1
32	10-705	Foot Rest	1



ENGINE HOOD & ROLL BAR DRAWING

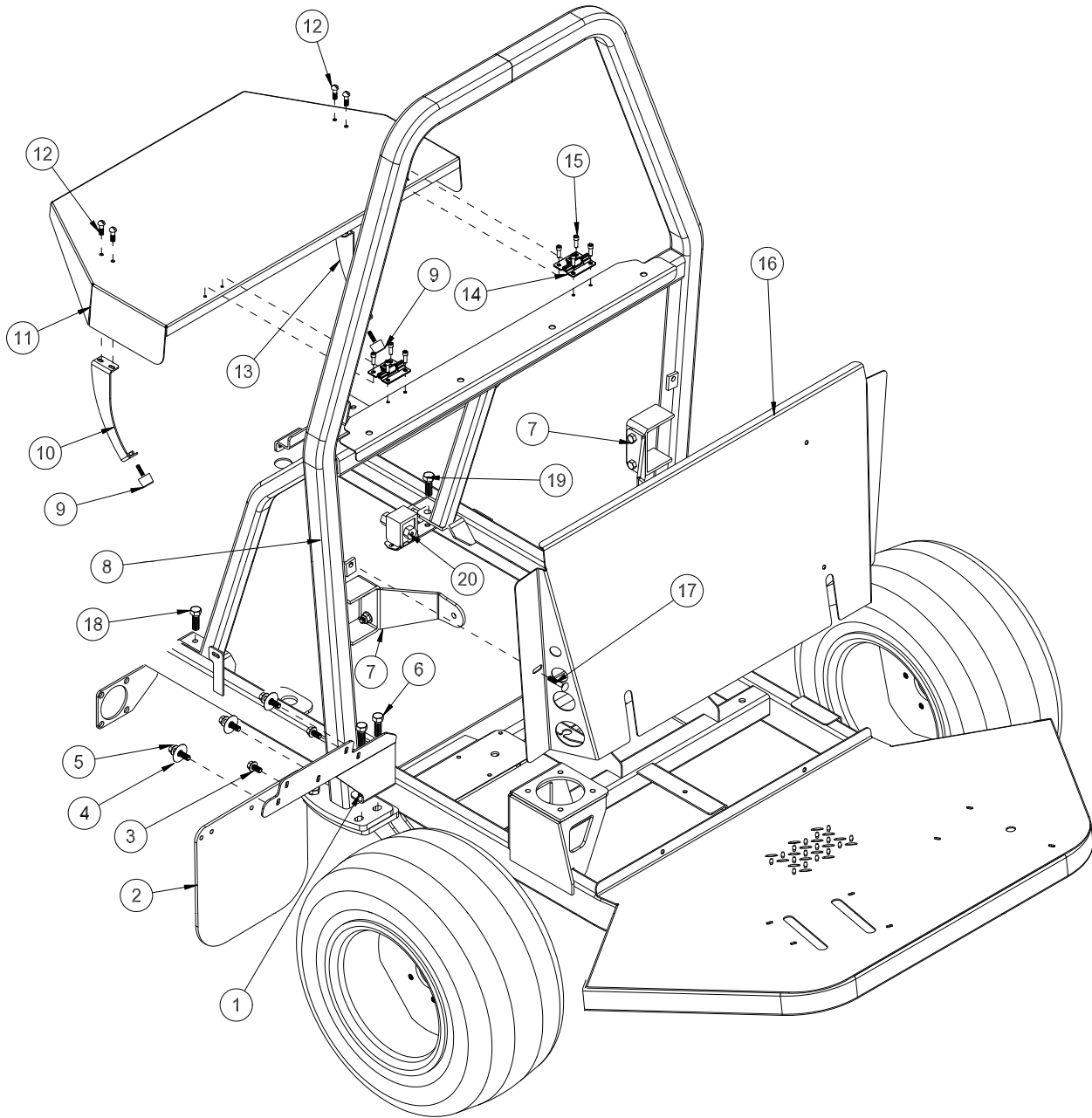

PARTS

ENGINE HOOD AND ROLL BAR PARTS LIST

REF#	PART#	DESCRIPTION	QUANTITY
1	15-940	RH Fender Brace	1
	15-939	LH Fender Brace (not shown)	1
2	20-659	Mud Flap	2
3	HBC-516-18-100	Carriage Bolt, $\frac{5}{16}$ -18 x 1	4
	HNFL-516-18	Flange-Loc Nut, $\frac{5}{16}$ - 18	4
4	HB-14-20-075	Hex Bolt, $\frac{1}{4}$ -20 x $\frac{3}{4}$	6
	HNFL-14-20	Flange-Loc Nut, $\frac{1}{4}$ - 20	6
5	HWF-14-150	Fender Washer, $\frac{1}{4}$ x $1\frac{1}{2}$	6
6	HB-12-13-175	Hex Bolt, $\frac{1}{2}$ - 13 x $1\frac{3}{4}$	10
	HW-12	Flat Washer, $\frac{1}{2}$	10
	HNTL-12-13	Lock Nut, $\frac{1}{2}$ - 13	10
7	15-935	Seat Belt Bracket	2
	HB-12-13-150	Hex Bolt, $\frac{1}{2}$ - 13 x $1\frac{1}{2}$	4
	HNTL-12-13	Lock Nut, $\frac{1}{2}$ - 13	4
8	15-922	Roll Bar	1
9	15-013	Rubber Bumper	2
	HNFL-14-20	Flange-Loc Nut, $\frac{1}{4}$ - 20	2
10	15-952	RH Hood Stand	1
11	15-936	Engine Hood	1
12	HSTP-516-18-075	Truss Head Screw, $\frac{5}{16}$ -18 x $\frac{3}{4}$	4
	HNFL-516-18	Flange-Loc Nut, $\frac{5}{16}$ - 18	4
13	15-951	LH Hood Stand	1
14	32-695	Adjustable Hinge	2
15	HSM-10-32-063	Machine Screw, 10-32 x $\frac{5}{8}$	8
	HNFL-10-32	Flange-Loc Nut, 10 - 32	8
16	15-934	Back Panel	1
	9023	Heat Reflective Matting (18 x 25.5)	$\frac{1}{4}$ Sheet
17	HB-38-16-075	Hex Bolt, $\frac{3}{8}$ -16 x $\frac{3}{4}$	2
	HNFL-38-16	Flange-Loc Nut, $\frac{3}{8}$ -16	2
18	hb-38-16-125	Hex Bolt, $\frac{3}{8}$ - 16 x $1\frac{1}{4}$	1
	HNTL-38-16	Lock Nut, $\frac{3}{8}$ - 16	1
19	HB-38-16-150	Hex Bolt, $\frac{3}{8}$ - 16 x $1\frac{1}{2}$	1
	HNTL-38-16	Lock Nut, $\frac{3}{8}$ - 16	1
20	15-931	Fuel Pump mount	1
	76-471	Fuel Pump	1

CONTROL PANEL AND STEERING DRAWING

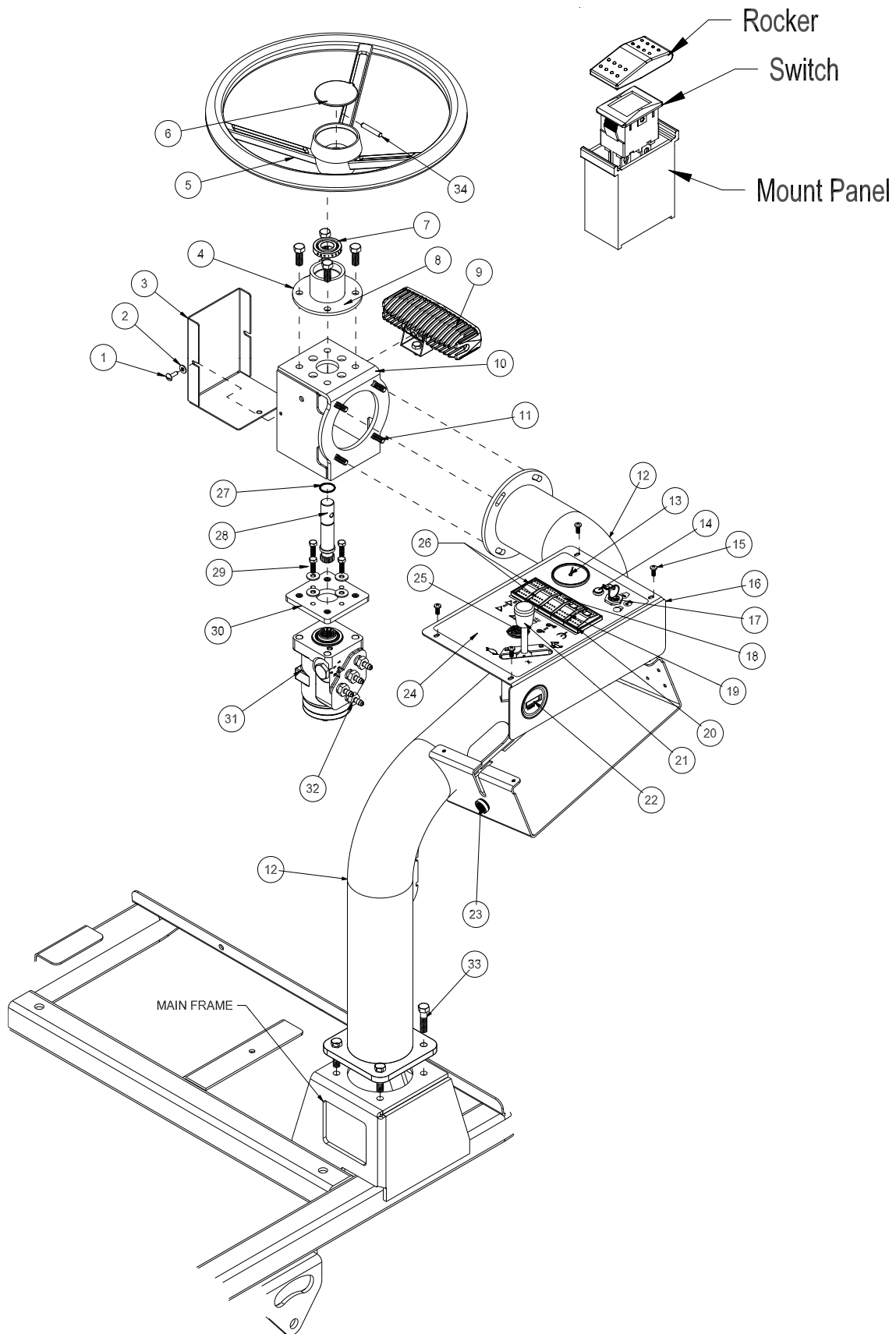

PARTS

CONTROL PANEL AND STEERING PARTS LIST

REF#	PART#	DESCRIPTION	QUANTITY
1	HSM-10-32-063	Machine Screw, #10 -32 x 5/8	2
2	HW-10	Flat Washer, #10	2
3	10-704	Steering Box Cover	1
4	HB-38-16-100	Hex Bolt, 3/8 -16 x 1	4
	HWL-38	Lock Washer, 3/8	4
5	20-057	Steering Wheel	1
6	20-129	Steering Wheel Cap	1
7	10-711	Ball Bearing	1
8	10-698	Steering Column	1
9	10-732	LED Head Light	1
10	10-682	Steering Box	1
11	HBC-516-18-100	Carriage Bolt, 5/16 - 18 x 1	4
	HNFL-516-18	Flange-Loc Nut, 5/16 - 18	4
12	10-683	Side Control Arm	1
13	30-356	GPS Speedometer w/Connectors	1
14	50-359	Oil Warning Indicator Light	1
	8853	Female Spade Connector	1
	8958	Male Spade Connector	1
15	HSM-10-32-100	Machine Screw, #10 -32 x 1	4
	HNFL-10-32	Flange-Loc Nut, #10- 32	4
16	10-684	Control Panel	1
17	13-488	Ignition Switch	1
18	LED Head Light		
	15-727	Rocker	1
	15-729	Panel Mount Middle	1
	15-782	Switch, On-None-Off	1
19	Spray Pump		
	15-731	Amber Rocker	1
	15-729	Panel Mount Middle	1
	15-726	Lighted Switch	1
20	Cruise Control		
	15-732	Green Rocker	1
	15-726	Lighted Switch	1
	15-725	Panel Mount End	1
21	45-118	Throttle Cable	1
22	12-804	Hour Meter	1
23	77-207	Buzzer	1
	8875	Male Bullet	1
	8874	Female Bullet	1
	8963	HEat Shrink	2
24	10-657	Decal, Control Panel	1
25	32-576	Dual USB Power Charger	1
26	RH and LH Booms		
	15-725	Panel Mount End	1
	15-729	Panel Mount Middle	1
	15-727	Rocker	2
	15-728	Centering Switch, On-Off-On	2
27	HRR-075	Retaining Ring, 3/4"	1
28	10-708	Splined Steering Shaft	1
29	HBM-6-1-16	Metric Bolt, #6 - 1 x 16	4
30	10-689	Orb Adapter	1
31	15-301	Orbtirol	1
32	18-169	3/8 Adapter Fitting	4
33	HB-38-16-100	Hex Bolt, 3/8-16-100	4
	HNFL-38-16	Flange-Loc Nut, 3/8-16	4
34	HRP-14-150	Roll Pin, 1/4 x 1 1/2	1

FOOT PEDAL LINKAGE DRAWING

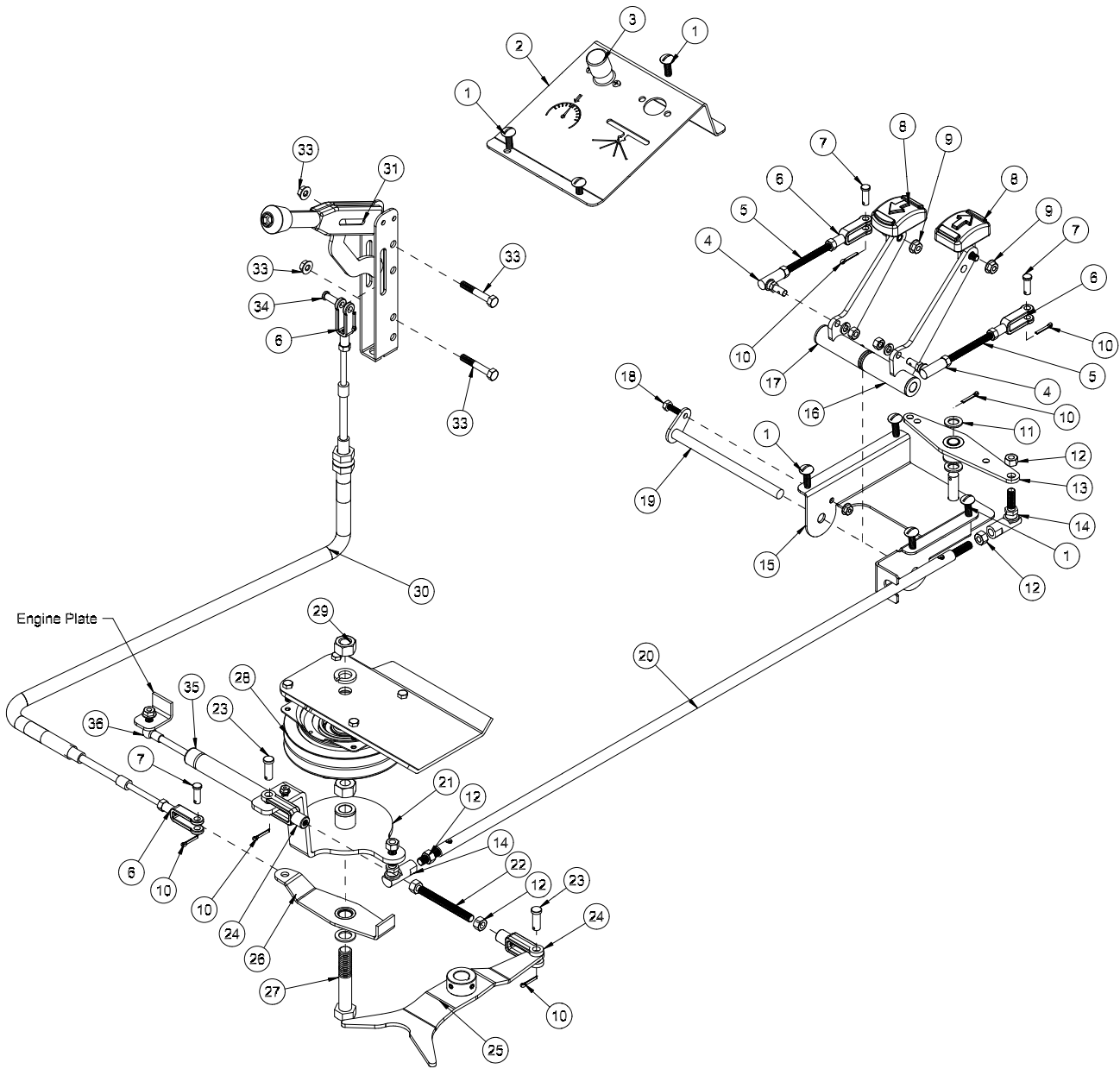

FOOT PEDAL LINKAGE PARTS LIST

REF#	PART#	DESCRIPTION	QUANTITY
1	HSTP-516-18-100	Truss Head Screw, ⁵ / ₁₆ - 18 x 1	7
	HNTL-516-18	Lock Nut ⁵ / ₁₆ - 18	7
2	10-705	Foot Rest	1
3	33-509	Cruise Control Foot Switch	1
4	21-462	Ball Joint, ⁵ / ₁₆ -24	2
	HN-516-24	Hex Nut, ⁵ / ₁₆ - 24	2
	HWL-516	Lock Washer, ⁵ / ₁₆	2
5	10-598	Connector Rod	2
	HN-516-24	Hex Nut, ⁵ / ₁₆ - 24	4
6	11-100	Yoke, ⁵ / ₁₆ - 24	4
7	HCP-516-100	Clevis Pin, ⁵ / ₁₆ x 1	4
8	45-022	Molded Foot Pedal	2
9	HBFL-516-18-075	Flange Whiz-loc Bolt, ⁵ / ₁₆ -18 x ³ / ₄	2
	HNFL-516-18	Flange Whiz-loc Nut, ⁵ / ₁₆ -18	2
10	HP-18-100	Cotter Pin, ¹ / ₈ x 1	5
11	HMB-12-14	Machine Bushing, ¹ / ₂ x 14GA	2
12	HN-38-24	Hex Nut, ³ / ₈ - 24	6
13	15-924	Pedal Relay	1
14	21-173	Ball Joint, ³ / ₈ -24	2
15	10-674	Pedal Mount	1
16	10-677	Forward Pedal Assembly	1
	76-128	Bushing	2
	HG-14-28-180	Grease Zerk	1
17	10-678	Reverse Pedal Assembly	1
	76-128	Bushing	2
	HG-14-28-180	Grease Zerk	1
18	HB-14-20-075	Hex Bolt, ¹ / ₄ - 20 x ³ / ₄	1
	HNFL-14-20	Flange Whiz-loc Nut, ¹ / ₄ - 20	1
19	10-673	Pedal Pivot	1
20	15-926	Control Link	1
21	15-923	Control Relay	1
22	52-133	Brake Rod	1
23	HCP-38-113	Clevis Pin, ³ / ₈ x 1 ¹ / ₈	2
24	21-351	Linkage Yoke, ³ / ₈ -24	2
25	20-652	Shift Arm	1
26	15-927	Speed Boss Arm	1
27	HB-58-11-400	Hex Bolt, ⁵ / ₈ -11x 4	1
	HMB-58-14	Machine Bushing, ⁵ / ₈ x 14GA	3
28	33-084	Magnetic Coil	1
29	HN-58-11	Hex Nut, ⁵ / ₈ -11	2
	HWL-58	Lock Washer, ⁵ / ₈	1
30	10-658	Speed Boss Cable	1
31	10-120	Spray Boss Handle	1
32	10-134	Handle Spacer	2
33	HB-516-18-200	Hex Bolt, ⁵ / ₁₆ -18 x 2	2
	HNTL-516-18	Lock Nut, ⁵ / ₁₆ - 18	2
34	HCP-14-075	Clevis Pin, ¹ / ₄ x ³ / ₄	1
	HP-18-100	Cotter Pin, ¹ / ₈ x 1	1
35	20-649	Dampner	1
36	26-034	Ball Stud	2
	HNFL-10-32	Flange Whiz-loc Nut, #10- 32	2

FRONT AXLE DRAWING

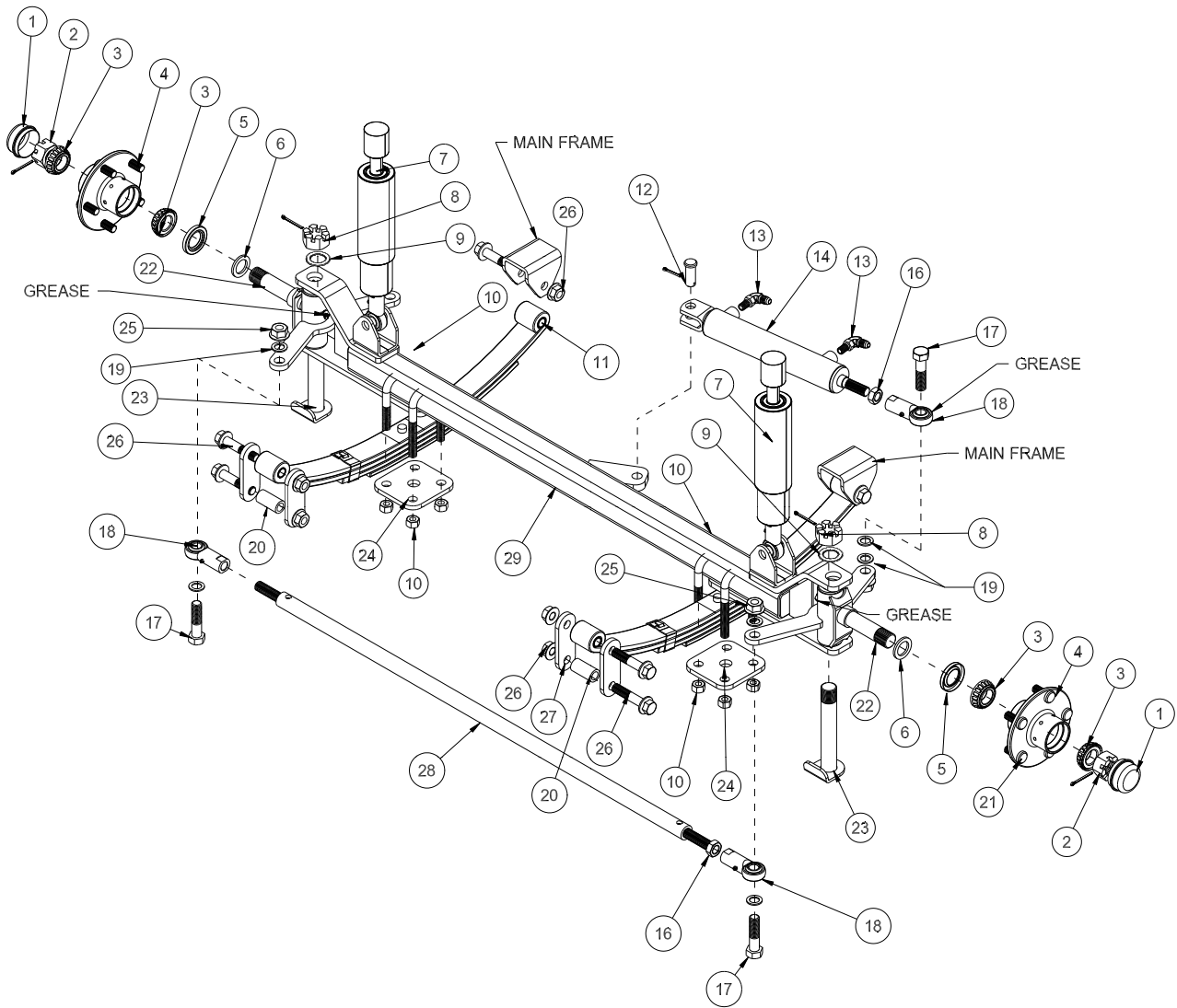

PARTS

FRONT AXLE PARTS LIST

REF#	PART#	DESCRIPTION	QUANTITY
1*	33-073-02	Dust Cap	2
2	HNAR-100-14	Slotted Jam Nut, 1 - 14	2
	HP-18-150	Cotter Pin, 1/8 - 1 1/2	2
3*	11-043	Bearing	4
4	80-019	Hub (includes * items)	2
5*	11-041	Oil Seal	2
6	HMB-100-10	Machine Bushing, 1 x 10GA	2
7	20-617	Shock Absorbers	2
8	HNA-100-14	Slotted Nut, 1 - 14	2
	HP-18-150	Cotter Pin, 1/8 - 1 1/2	2
9	HMB-100-14	Machine Bushing, 1 x 14GA	2
10	20-555	U-bolt	4
	HNTL-12-13	Lock Nut, 1/2 - 13	8
11	20-740	Leaf Spring	2
12	HCP-58-175	Clevis Pin, 5/8 - 1 3/4	1
	HP-18-100	Cotter Pin, 1/8 x 1	1
13	18-168	90° Elbow	2
14	15-839	Hydraulic Cylinder	1
	15-839-01	Seal Kit	1
16	HNJ-58-18	Jam Nut, 5/8 - 18	3
17	HB-58-11-250	Bolt, 5/8 - 11 x 2 1/2	3
18	18-154	Rod End	3
	HG-14-28-180	Grease Fitting, 1/4 - 28 x 180°	3
19	HMB-58-14	Machine Bushing, 5/8 x 14GA	6
20	30-251	Bushing (pressed in mainframe)	2
21	60-268	Stud, 1/2 - 20 x 1 5/16	10
22	10-582	Spindle	2
	18-035	Bushing (part of Spindle; 2 per)	4
	HG-14-28-45	Grease Fitting, 1/4 - 28 x 45°	2
23	16-076	King Pin	2
24	20-538	Spring Mount	2
25	HNTL-58-11	Lock Nut, 5/8 - 11	3
26	HB-916-18-325	Hex Bolt, 9/16 - 18 x 3 1/4	6
	HNTL-916-18	Lock Nut, 9/16 - 18	6
27	15-930	Shackle	4
28	10-583	Steering Link	1
29	10-629	Front Axle	1

OIL AND FUEL TANK DRAWING

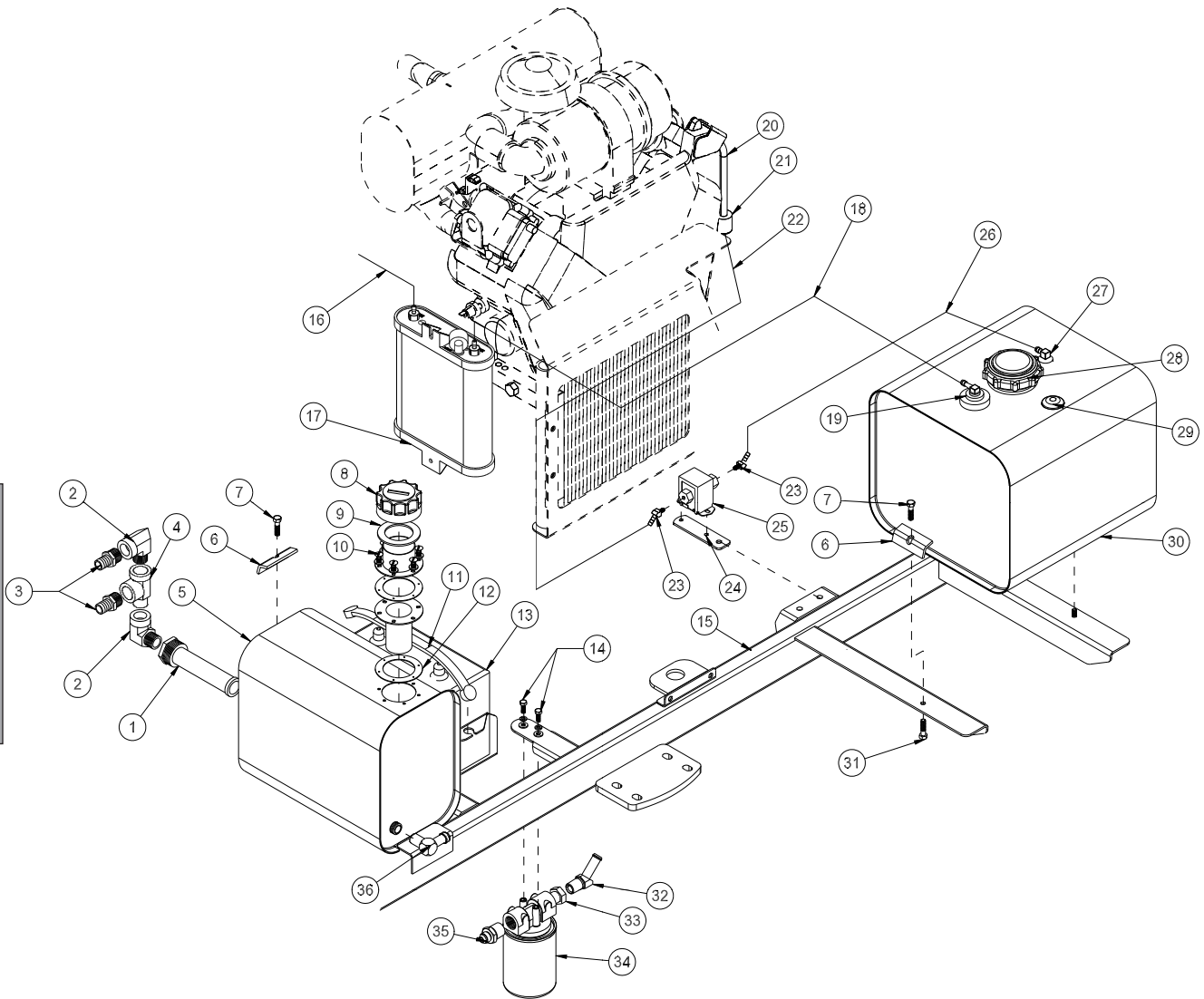

PARTS

OIL AND FUEL TANK PARTS LIST

REF#	PART#	DESCRIPTION	QUANTITY
1	60-213	Strainer	1
2	18-140	Street Elbow	2
3	18-249	Barb Fitting	2
4	18-093	Straight Tee	1
5	60-473	Oil Tank	1
6	75-792	Tank Hold Down	3
7	HB-516-18-150	Hex Bolt, $\frac{5}{16}$ - 18 x $1\frac{1}{2}$	3
	HW-516	Flat Washer, $\frac{5}{16}$	6
	HNFL-516-18	Flange Whiz-loc Nut, $\frac{5}{16}$ - 18	3
8	13-747	Filler Breather	1
9	13-586-01	Cap Gasket	1
10	13-586-03	Filler Neck	1
	HSM-10-32-063	Machine Screw, 10-32 x $\frac{5}{8}$	6
	HWL-10	Lock Washer, #10	6
11	8-603	Battery Hold Down - Rubber Strap	1
12	13-586-02	Bottom Gasket	1
13	33-216	Battery	1
14	HB-14-20-075	Hex Bolt, $\frac{1}{4}$ - 20 x $\frac{3}{4}$	2
	HW-14	Flat Washer, $\frac{1}{4}$	2
	HWL-14	Lock Washer, $\frac{1}{4}$	2
15	15-925	Main Frame	1
16	8800-48	Fuel Line, $\frac{1}{4}$ " x 48"	1
	18-186	Hose Clamp	2
17	20-721	1.8l Carbon Canister	1
18	8800-70	Fuel Line, $\frac{1}{4}$ " x 70"	1
	18-186	Hose Clamp	2
19	42-814-05	Rollover Valve	1
	42-814-06	Valve Grommet	1
20	8800-10	Fuel Line, $\frac{1}{4}$ " x 10	1
	18-186	Hose Clamp	2
21	50-403	In-line Fuel Filter	1
22	8800-14	Fuel Line, $\frac{1}{4}$ " x 14	1
	18-186	Hose Clamp	2
23	18-420	45° Hose Barb	2
24	15-931	Fuel Pump Mount	1
25	76-471	Electric Fuel Pump	1
26	8800-29	Fuel Line, $\frac{1}{4}$ " x 29	1
	18-186	Hose Clamp	2
27	20-692-01	Top Draw	1
	42-814-07	Top Draw Grommet	1
28	20-694	Cap	1
29	20-692-02	Fuel Gauge	1
	20-692-03	Grommet	1
30	20-692	10 Gallon Gas Tank	1
31	HB-516-18-100	Hex Bolt, $\frac{5}{16}$ - 18 x $1\frac{1}{2}$	2
	HNFL-516-18	Flange Whiz-loc Nut, $\frac{5}{16}$ - 18	2
32	23-143	Connector	1
33	18-008	Pipe Thread Reducer	1
34	26-016	Oil Filter	1
	23-031	Replacement Filter	1
35	18-243	Male Connector	1
36	23-142	Connector	1

SEAT PANEL DRAWING

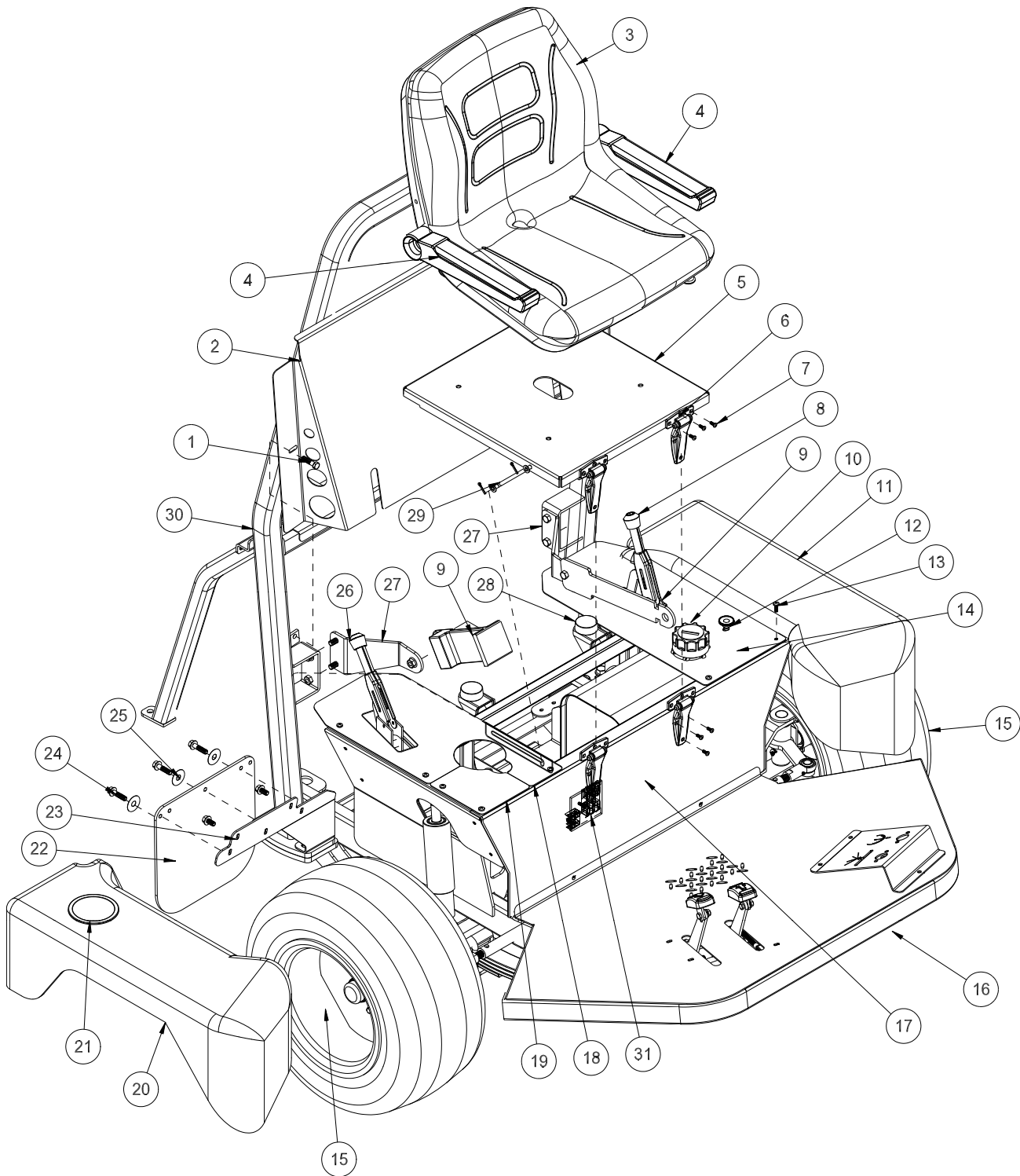

PARTS

SEAT PANEL PARTS LIST

REF#	PART#	DESCRIPTION	QUANTITY
1	HSTP-516-18-075	Truss Head Screw, $\frac{5}{16}$ - 18 x $\frac{3}{4}$	2
	HNFL-516-18	Flange-Loc Nut, $\frac{5}{16}$ - 18	2
2	15-934	Back Panel	1
	9023	Heat Reflective Matting (18 x 25.5)	1 Sheet
3	14-294	Seat Kit	1
	14-292	Seat Switch	1
	14-800	Seat Rail	1
	HB-516-18-125	Hex Bolt, $\frac{5}{16}$ - 18 x $1\frac{1}{4}$	4
	HW-516	Flat Washer, $\frac{5}{16}$	4
	HWL-516	Lock Washer, $\frac{5}{16}$	4
	HN-516-18	Hex Nut, $\frac{5}{16}$ - 18	4
4	10-706	Arm Rest Kit	1
5	10-714	Seat Panel	1
6	27-055	Hinge	2
7	HSMFCS-10-32-050	Machine Screw, #10-32- $\frac{1}{2}$	12
	HNFL-10-32	Flange-Loc Nut, #10-32	12
8	10-120	Speed Boss Handle	1
9	76-198-03	Seat Belt	1
10	13-747	Filler Breather	1
	60-473	Oil Tank	1
11	10-662	LH Front Fender	1
12	80-020	Choke Cable	1
13	HSDPS-14-100	Pan Head Drill Screw, $\frac{1}{4}$ x 1	8
14	15-954	LH Control Panel	1
15	16-857	Tire and Wheel	2
	16-857-01	Tire, 20 x 10 - 10NHS 4 Ply	2
	42-161-02	Wheel	2
16	15-925	Main Frame	1
17	10-680	Seat Frame	1
18	15-953	RH Control Panel	1
19	10-694	RH Panel Cover	1
20	10-663	RH Front Fender	1
21	15-781	Drink Cup Holder	1
22	20-659	Mud Flap	2
23	15-940	RH Fender Brace	1
	15-939	LH Fender Brace (not shown)	1
	HBC-516-18-100	Carriage Bolt, $\frac{5}{16}$ - 18 x 1	4
	HNFL-516-18	Flange-Loc Nut, $\frac{5}{16}$ - 18	4
24	HB-14-20-075	Hex Bolt, $\frac{1}{4}$ - 20 x $\frac{3}{4}$	6
	HNFL-14-20	Flange-Loc Nut, $\frac{1}{4}$ - 20	6
25	HWF-14-150	Fender Washer, $\frac{1}{4}$ x $1\frac{1}{2}$	6
26	60-106	Park Brake Handle	1
27	15-935	Seat Belt Bracket	2
	HB-12-13-150	Hex Bolt, $\frac{1}{2}$ - 13 x $1\frac{1}{2}$	4
	HNTL-12-13	Lock Nut, $\frac{1}{2}$ - 13	4
28	50-081	Rubber Bumper	2
	HNTL-38-16	Lock Nut, $\frac{3}{8}$ - 16	2
29	10-697	Seat Prop Rod	1
	HW-38	Flat Washer, $\frac{3}{8}$	2
	HP-18-075	Cotter Pin, $\frac{1}{8}$ x $\frac{3}{4}$	2
30	15-922	Roll Bar	1
	HB-12-13-175	Hex Bolt, $\frac{1}{2}$ - 13 x $1\frac{3}{4}$	8
	HW-12	Flat Washer, $\frac{1}{2}$	8
	HNTL-12-13	Lock Nut, $\frac{1}{2}$ - 13	4
31	33-271	Fuse Panel	1

PUMP DRAWING

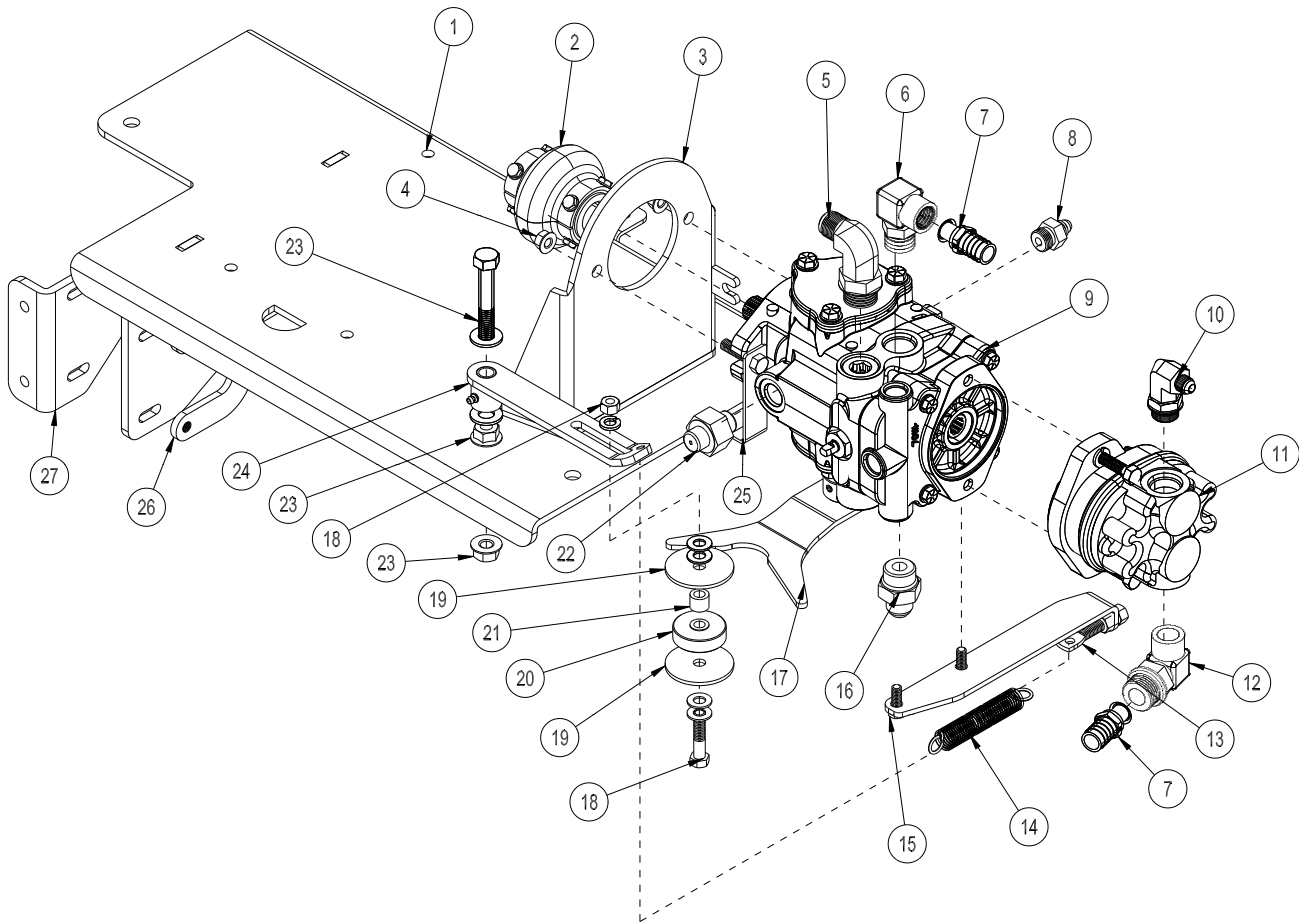

PARTS

PUMP PARTS LIST

REF#	PART#	DESCRIPTION	QUANTITY
1	15-944	Engine Plate	1
2	76-465	Pump Coupling Complete	1
	76-466	7/8 Coupling Half	1
	76-467	1 1/8 Coupling Half	1
	76-468	Sleeve M42	1
3	15-774	Pump Mount	1
	HB-38-16-125	Hex Bolt, 3/8 - 16 x 1 1/4	2
	HW-38	Flat Washer, 3/8	2
	HNTL-38-16	Nylon Lock Nut, 3/8 -16	2
4	HB-38-16-150	Hex Bolt, 3/8 - 16 x 1 1/2	2
	HW-516	Flat Washer, 5/16	2
	HNTL-38-16	Nylon Lock Nut, 3/8 - 16	2
5	18-204	Elbow	1
6	23-130	Elbow	1
7	18-133	Hose Barb	2
8	18-241	Straight Thread Connector	1
9	76-638	Hydrostat Pump	1
	23-145	O-ring	1
10	32-022	Straight Thread Elbow	1
11	76-197	Gear Pump	1
	HB-38-16-125	Hex Bolt 3/8 - 16 X 1 1/4	2
	HNFL-38-16	Flange Whiz-loc Nut, 3/8 - 16	2
12	23-133	Adjustable Elbow, 90°	1
13	42-537	Spade Hex Bolt, 3/8"	1
14	21-445	Spring	1
15	15-876	Spring Mount	1
16	15-702	Adapter	1
17	20-652	Shift Arm	1
	HSSHS-14-20-025	Set Screw, 1/4 - 20 x 1/4	1
18	HB-38-16-175	Hex Bolt, 3/8 - 16 x 1 3/4	1
	HW-38	Flat Washer, 3/8	5
	HN-38-16	Hex Nut, 3/8 - 16	1
	HWL-38	Lock Washer, 3/8	1
19	20-594	Guide Disc	2
20	14-266	Ball Bearing	1
21	18-270	Oilite Bushing	1
22	18-227	Straight Thread Connector	1
23	HB-12-13-300	Hex Bolt, 1/2 - 13 x 3	1
	HN-12-13	Hex Nut, 1/2 - 13	2
	HMB-12-14	Machine Bushing, 1/2 x 14GA	2
	HWL-12	Lock Washer, 1/2	1
24	15-854	Tensioner Arm	1
	HG-14-28-180	Grease Fitting, 1/4 - 28 x 180°	1
25	15-928	Cable Support	1
26	15-938	Spray Pump Adjuster (threaded)	1
27	15-943	Spray Pump Mount	1

ENGINE AND EXHAUST DRAWING

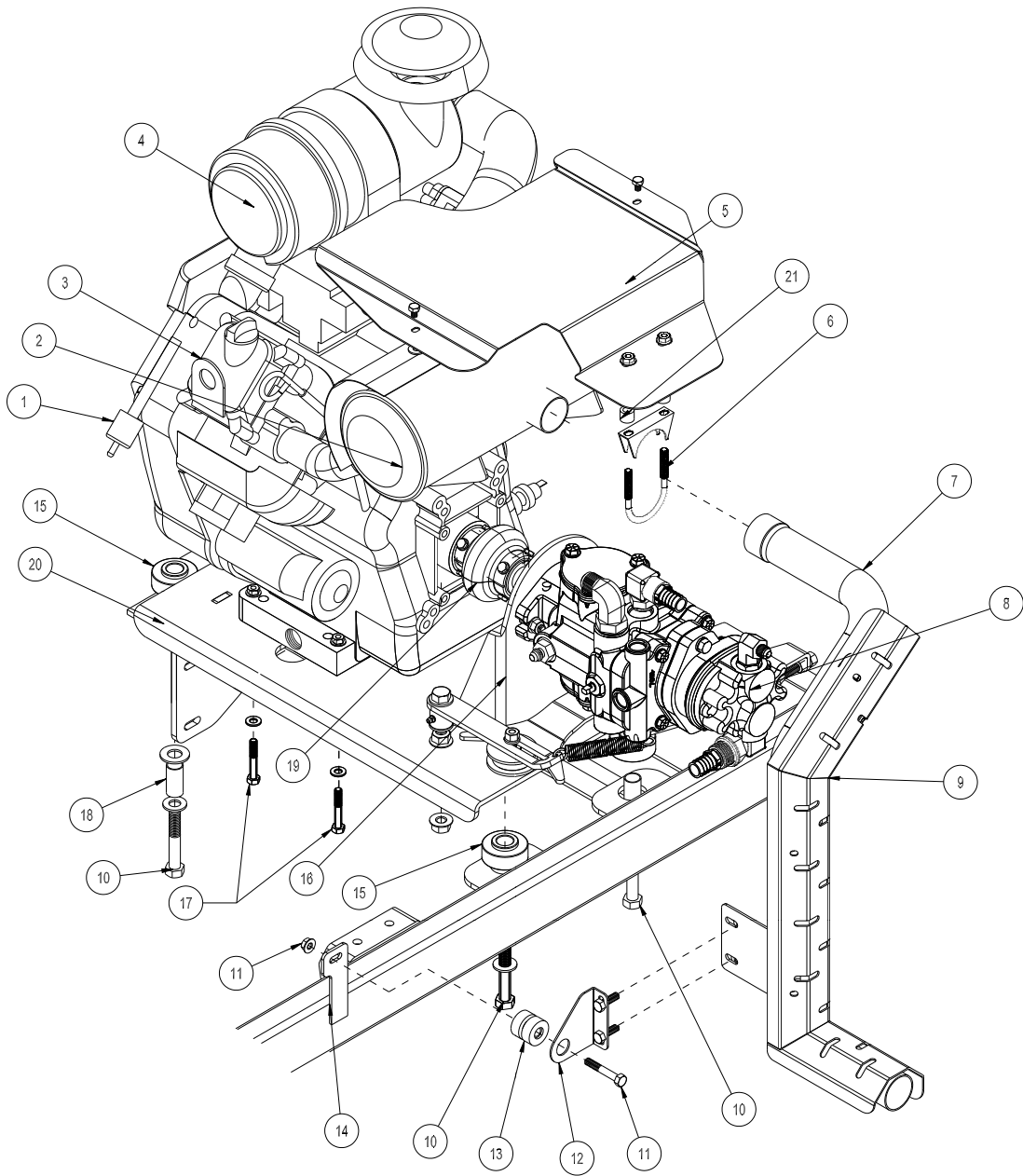

PARTS

Cyclonic air cleaner
76-395-04

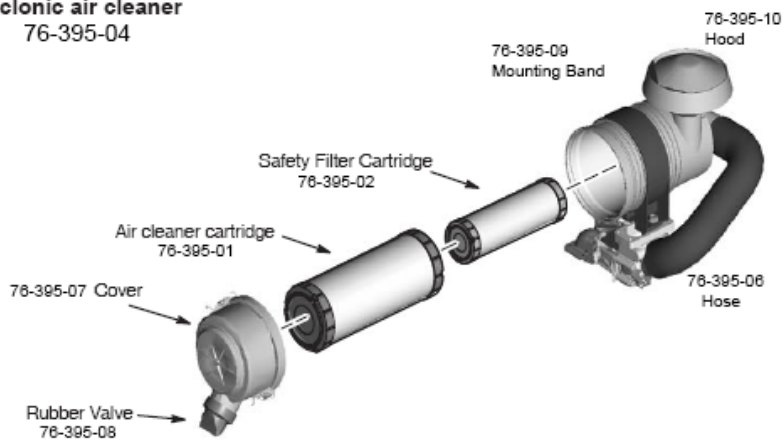

ENGINE AND EXHAUST PARTS LIST

REF#	PART#	DESCRIPTION	QUANTITY
1	50-403	In-line Fuel Filter	1
2	76-447	Muffler	1
	HB-14-20-038	Hex Bolt, 1/4 - 20 x 3/8	2
	HW-14	Flat Washer, 1/4	
	HNFL-14-20	Flange Whiz-loc Nut, 1/4- 20	2
3	76-636	Engine, Briggs & Stratton 35HP	1
	76-487	Engine Oil Filter	1
	21-161	Wire Block	1
	18-118	Pipe Plug	1
4	76-395-04	Cyclonic Air Cleaner	1
	76-395-01	Air Cleaner Cartridge	1
	76-395-02	Safety Filter Cartridge	1
5	15-955	Heat Shield	1
6	50-394	Muffler Clamp	1
7	15-963	Tailpipe	1
	HB-516-18-200	Hex Bolt, 5/16 - 18 x 2	1
	HNFL-516-18	Flange Whiz-loc Nut 5/16 - 16	1
8	76-638	Hydrostat Pump	1
	76-197	Gear Pump	1
9	15-962	Tailpipe Guard	1
	HB-516-18-075	Hex Bolt, 5/16 - 18 x 3/4	4
	HNTL-516-18	Nylon Lock Nut, 5/16 - 18	4
10	HB-12-13-300	Hex Bolt, 1/2 - 13 x 3	3
	HW-58	Flat Washer, 5/8	3
	HW-12	Flat Washer, 1/2	3
11	HB-516-18-200	Hex Bolt, 5/16 - 18 x 2	1
	HNFL-516-18	Flange Whiz-loc Nut 5/16 - 16	1
12	15-961	Insulator Mount	1
13	52-124	Rubber Insulator	1
14	15-925	Main Frame	1
15	60-107	Rubber Insulator	6
16	15-774	Pump Mount	1
17	HB-516-18-200	Hex Bolt, 5/16 - 18 x 2	4
	HW-516	Flat Washer, 5/16	4
	HNTL-516-18	Nylon Lock Nut, 5/16 - 18	4
18	60-168	Spacer	3
19	76-465	Pump Coupling Complete	1
20	15-944	Engine Plate	1
21	45-154	Spacer	2



SPRAY PUMP DRAWING

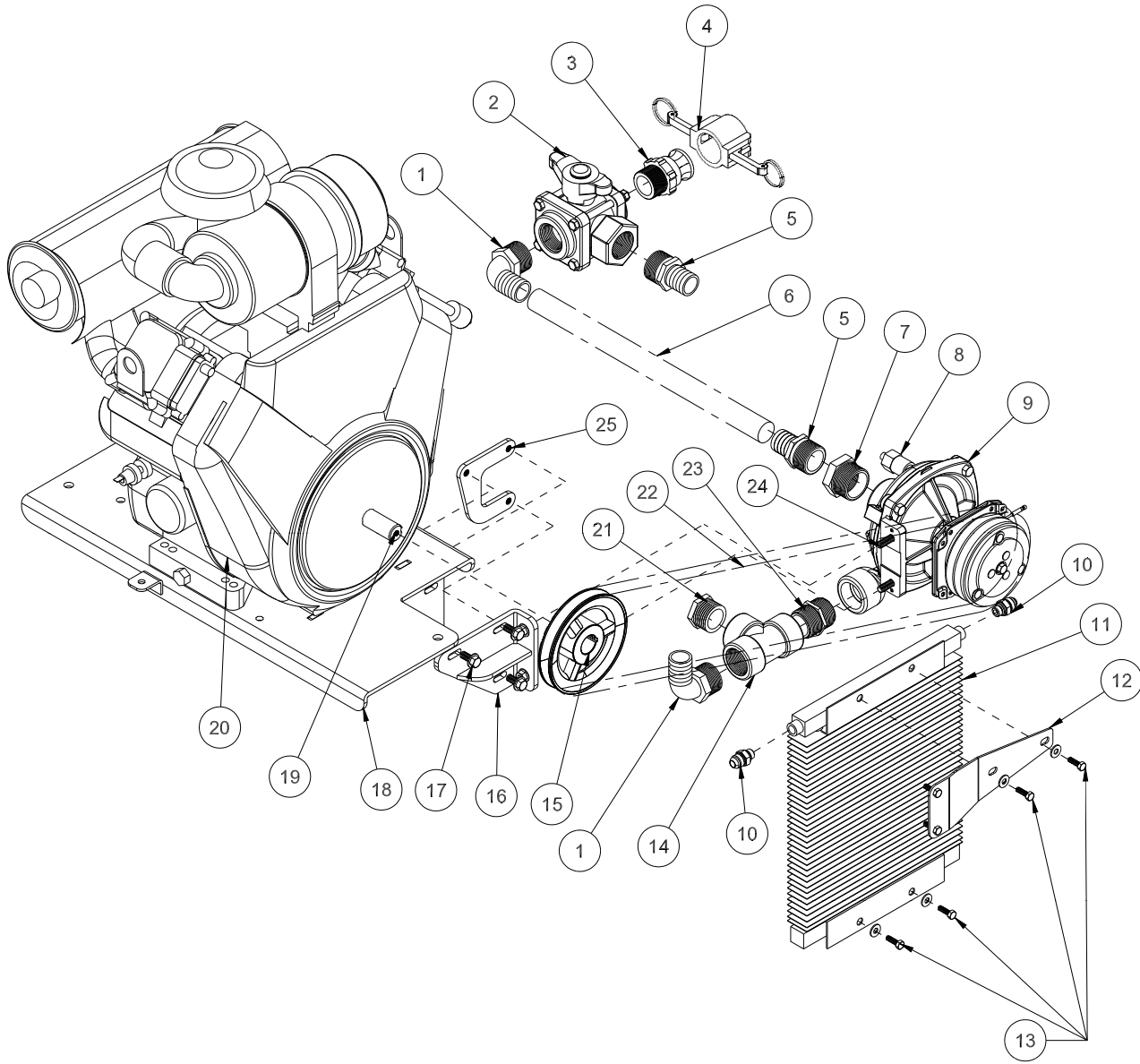

PARTS

SPRAY PUMP PARTS LIST

REF#	PART#	DESCRIPTION	QUANTITY
1	16-156	Elbow	2
2	18-372	3-Way Valve	1
	18-372-01	T-Handle	1
3	16-180	Quick Coupler Male	1
4	16-935	Quick Coupler Cap	1
5	16-161	Fitting	2
6	8897-19	Discharge Hose, 1 1/4" x 19"	1
	18-222	Hose Clamp	2
7	16-825	Hex Bushing	1
8	33-480	Pressure Switch	1
9	15-970	Spray Pump	1
10	18-509	Straight Thread Connector	2
11	15-624	Oil Cooler	1
12	15-929	Upper Cooler Mount	1
13	HB-14-20-075	Hex Bolt, 1/4 - 20 x 3/4	6
	HW-14	Flat Washer, 1/4	6
	HNFL-14-20	Flange Lock Nut, 1/4 - 20	6
14	18-390	Tee	1
15	15-703	Pulley	1
16	15-943	Pump Mount	1
17	HB-38-16-125	Hex Bolt, 3/8 - 16 x 1 1/4	2
	HW-38	Flat Washer, 3/8	2
18	15-944	Engine Plate	1
19	76-466-01	Stub Shaft (comes with engine)	1
20	76-636	Briggs & Stratton 35 HP Engine	1
	76-487	Engine Oil Filter	1
21	10-389	Plug	1
22	16-869	Belt	1
23	16-880	Nipple	1
24	HB-38-16-150	Hex Bolt, 3/8 - 16 x 1 1/2	2
	HW-38	Flat Washer, 3/8	2
	HNTL-38-16	Nylon Lock Nut, 3/8 - 16	2
25	15-938	Spray Pump Adjuster (threaded)	1

TANK DRAWING

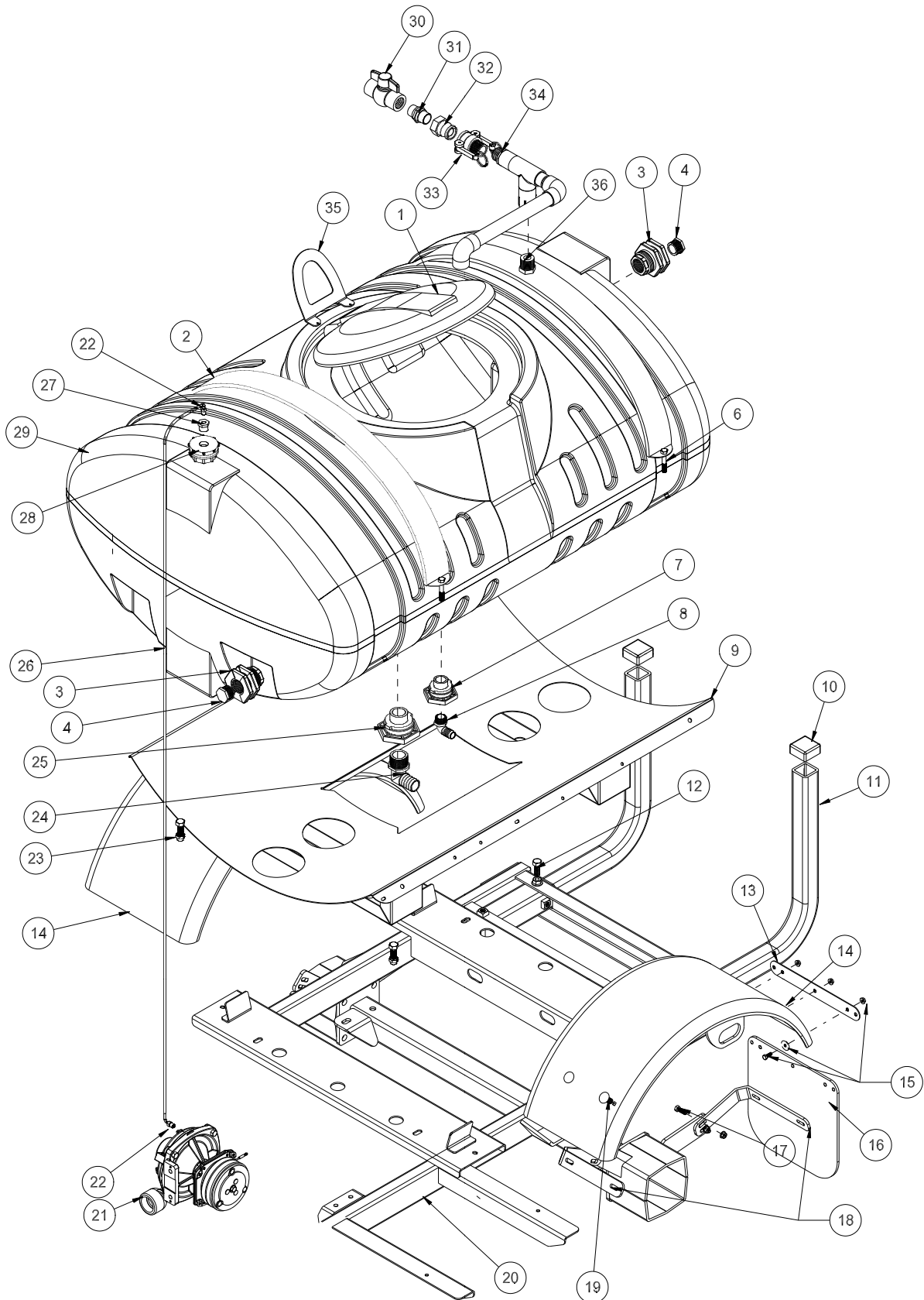

PARTS

TANK PARTS LIST

REF#	PART#	DESCRIPTION	QUANTITY
1	16-953	16" Hinged Lid Well with Gasket	1
	16-953-01	Gasket (for Lid)	1
	16-169	Strainer Basket	1
2	20-811	Tank Strap	1
3	16-945	1" Double Thread Fitting	2
4	16-162	1" Hex Plug	2
6	HB-38-16-250	Hex Bolt, $\frac{3}{8}$ - 16 x 2 $\frac{1}{2}$	4
	HW-38	Flat Washer, $\frac{3}{8}$	8
	HNTL-38-16	Nylon Lock Nut, $\frac{3}{8}$ - 16	4
7		$\frac{1}{2}$ " Double Thread Fitting (part of tank)	1
8	16-155	Elbow	1
9	15-932	Tank Carrier	1
10	16-557	Square Cap	2
11	17-615	Boom Support Tube	2
12	HB-12-13-150	Hex Bolt, $\frac{1}{2}$ - 13 x 1 $\frac{1}{2}$	4
	HNJ-12-13	Jam Nut, $\frac{1}{2}$ - 13	4
13	20-660	Mud Flap Strap	2
14	10-168	Rear Fender	2
15	HB-14-20-075	Hex Bolt, $\frac{1}{4}$ - 20 x $\frac{3}{4}$	6
	HWF-14-150	Fender Washer, $\frac{1}{4}$ x 1 $\frac{1}{2}$	6
	HNFL-14-20	Flange Whiz-loc Nut, $\frac{1}{4}$ - 20	6
16	20-659	Mud Flap	2
17	HBFL-516-18-075	Flange Whiz-loc Bolt, $\frac{5}{16}$ - 18 x $\frac{3}{4}$	8
	HNFL-516 - 18	Flange Whiz-loc Nut, $\frac{5}{16}$ - 18	8
18	10-466	Rear Fender Brackets	4
19	HBC-516-18-100	Carriage Hex Bolt, $\frac{5}{16}$ - 18 x 1	8
	HNFL-516-18	Flange Whiz-loc Nut, $\frac{5}{16}$ - 18	8
20	15-925	Main Frame	1
21	15-970	Hypro Pump	1
22	18-475	Male Elbow	2
23	HB-12-13-125	Hex Bolt, $\frac{1}{2}$ - 13 x 1 $\frac{1}{4}$	4
	HNFL-12-13	Flange Whiz-loc Nut, $\frac{1}{2}$ - 13	4
24	16-156	Elbow	1
25	16-194	1 $\frac{1}{4}$ Anti Vortex Fitting (part of tank)	1
26	9038-46	Tubing, $\frac{1}{4}$ x 46"	1
27	33-496	Reducer Bushing, $\frac{1}{2}$ to $\frac{1}{8}$	1
28	33-495	Bulkhead Fitting	1
29	20-802	200 Gallon Spray Tank	1
30	18-448	1" Ball Valve	1
31	16-851	1" Nipple	1
32	16-961	1" Adapter	1
33	16-962	1" Coupler	1
	16-962-01	Buna-N Gasket (for 16-962)	1
34	15-964	Air Gap Filler	1
35	10-639	Lid Stop	1
36	20-812	Tank Strap w/ plug	1

TURBO-QUAD AGITATOR DRAWING

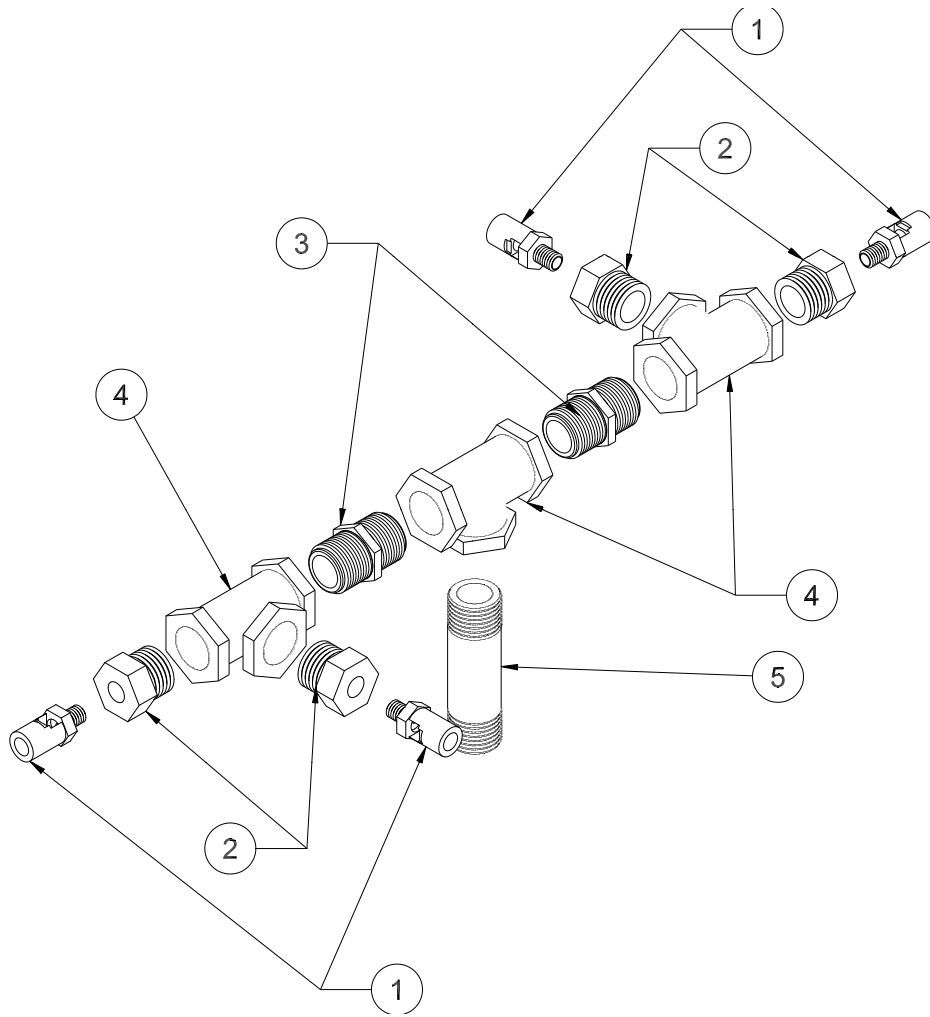

PARTS

TURBO-QUAD AGITATOR PARTS LIST

REF#	PART#	DESCRIPTION	QUANTITY
1	18-510	Mini Eductor	4
2	16-288	Reducer, $\frac{3}{4}$ x $\frac{1}{4}$	4
3	16-158	Close Nipple, $\frac{3}{4}$ x $\frac{3}{4}$	2
4	16-157	Female Pipe Thread Tee, $\frac{3}{4}$ x $\frac{3}{4}$ x $\frac{3}{4}$	3
5	16-172	Nylon Nipple, $\frac{3}{4}$ NPT x $3\frac{1}{2}$	1

PARK BRAKE AND REAR AXLE DRAWING

PARTS

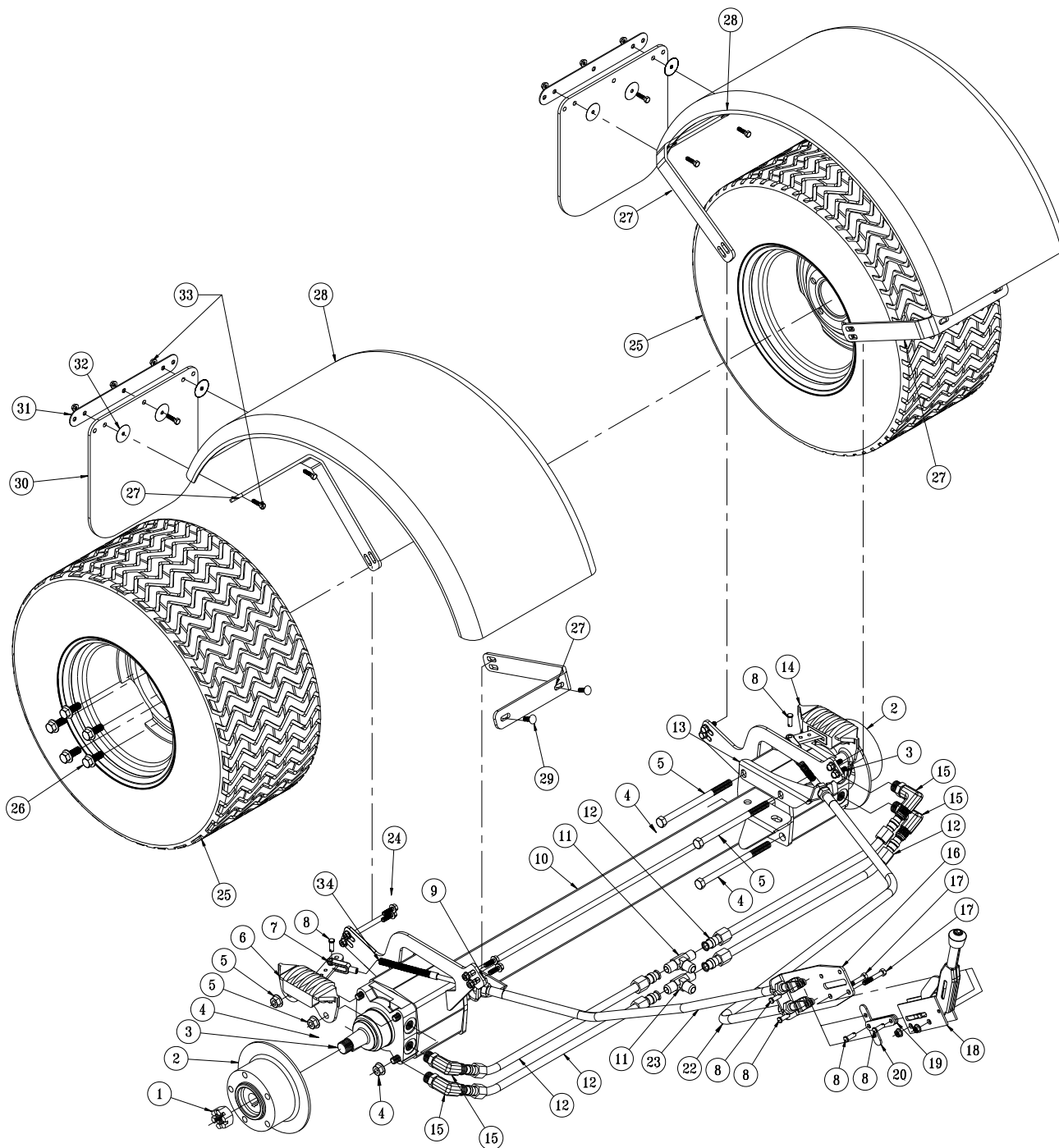

PARK BRAKE AND REAR AXLE PARTS LIST

REF#	PART#	DESCRIPTION	QUANTITY
1	14-265	Lug Nut (comes with wheel motor)	2
2	76-239	Brake Disc, 5-hole	2
3	76-238	Wheel Motor	2
	HMB-100-14	Machine Bushing, 1 x 14GA	1
	HWK-516-100	Woodruff Key, $\frac{5}{16}$ x 1 (comes with wheel motor)	2
4	HB-12-13-750	Hex Bolt, $\frac{1}{2}$ - 13 x $7\frac{1}{2}$	4
	HNFL-12-13	Flange Whiz-loc Nut, $\frac{1}{2}$ -13	4
5	HB-12-13-800	Hex Bolt, $\frac{1}{2}$ - 13 x 8	4
	HNFL-12-13	Flange Whiz-loc Nut, $\frac{1}{2}$ - 13	8
6	76-241	Right Caliper CW	1
	34-101-02	Pad Kit	1
7	11-100	Linkage Yoke, $\frac{5}{16}$ "	2
	HN-516-24	Hex Nut, $\frac{5}{16}$ - 24	2
8	HCP-516-100	Clevis Pin, $\frac{5}{16}$ x 1	6
	HP-18-075	Cotter Pin, $\frac{1}{8}$ x $\frac{3}{4}$	6
9	10-589	RH Brake Cable Bracket	1
10	15-921	Rear Axle	1
11	34-057	Tee	2
12	20-656	Hydraulic Tube	4
13	10-588	LH Brake Cable Bracket	1
14	76-240	Left Caliper CCW	1
	34-101-02	Pad Kit	1
15	34-122	Short Elbow	4
16	15-942	Cable Bracket	1
17	HB-516-18-200	Hex Bolt, $\frac{5}{16}$ -18 x 2	2
	HNTL-516-18	Lock Nut, $\frac{5}{16}$ - 18	2
18	60-106	Park Brake Lever Kit	1
19	45-074	Park Brake Link	2
20	10-591	Brake Equalizer	1
21	10-134	Spacer	2
22	15-913	LH Brake Cable	1
23	15-914	RH Brake Cable	1
24	HBFL-516-18-075	Flange Whiz-loc Bolt, $\frac{5}{16}$ - 18 x $\frac{3}{4}$	8
	HNFL-516 - 18	Flange Whiz-loc Nut, $\frac{5}{16}$ - 18	8
25	16-225	Rear Tire and Wheel	2
	16-225-01	Tire, 24 x 13.00 - 12NHS 4 Ply	2
	16-225-02	Wheel	2
26	60-268	Lug Bolt, $\frac{1}{2}$ -20 x $1\frac{5}{16}$	10
27	10-466	Rear Fender Brackets	4
28	10-168	Rear Fender	2
29	HBC-516-18-100	Carriage Hex Bolt, $\frac{5}{16}$ - 18 x 1	4
	HNFL-516-18	Flange Whiz-loc Nut, $\frac{5}{16}$ - 18	4
30	20-659	Mud Flap	2
31	20-660	Mud Flap Strap	2
32	HWF-14-150	Fender Washer, $\frac{1}{4}$ x $1\frac{1}{2}$	6
33	HB-14-20-075	Hex Bolt, $\frac{1}{4}$ - 20 x $\frac{3}{4}$	6
	HNFL-14-20	Flange Whiz-loc Nut, $\frac{1}{4}$ - 20	6
34	15-949	Compression Spring	2
	HW-14	Flat Washer, $\frac{1}{4}$	2

15-301 ORBITROL DRAWING

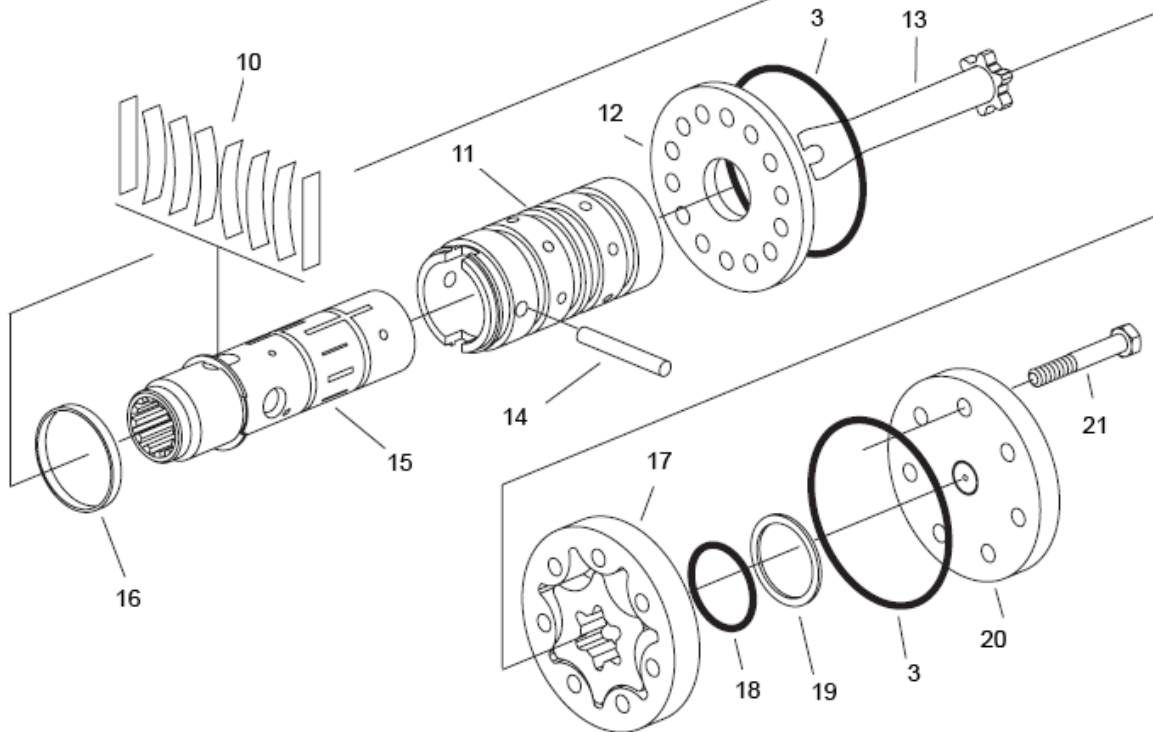
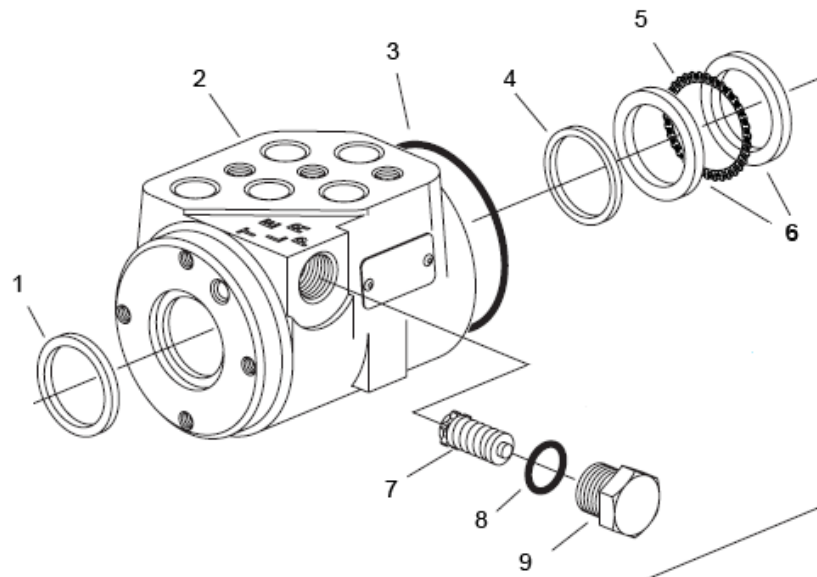

PARTS

15-301 ORBITROL PARTS LIST

REF #	PART #	DESCRIPTION	QUANTITY
1**	10-576-04	Dust Seal	1
2		Housing	1
3**		O-Ring Seal	3
4**		Quad Seal	1
5	10-576-03	Thrust Bearing	1
6	10-576-02	Bearing Race	2
7		Manual Steering Relief Valve	1
8**		O-ring	1
9		Plug	1
10‡		Standard Torque Centering Springs	1
11		Sleeve	1
12	15-301-06	Wear Plate	1
13	10-576-01	Drive	1
14	15-301-08	Drive Pin	1
15		Spool	1
16‡		Spring Retaining Ring	1
17	10-576-05	Gerotor	1
18**		O-Ring	1
19**		Seal Ring	1
20	15-301-03	End Cap	1
21	10-576-06	Cap Screw	7
**	15-301-01	Seal Kit	1
‡	15-301-15	Centering Spring Kit	1

15-301 ORBITROL SPECIFICATIONS

Inlet Relief Valve Setting	1020 psi (70 bar)
Nominal Flow	3 gpm (11 lpm)
Displacement	4.50 cu. in/ R (73.8 cu cm/R)
Check Valve for Manual Steering	Yes
Inlet Pressure Rating	2030 psi (140 bar)
Return Pressure Rating	145 psi (10 bar) Maximum
Fluid	SAE 10W-40 API Service SJ or higher Motor Oil
Ports	9/16 - 18 SAE O-Ring 4 Ports

76-638 HYDROSTATIC PUMP DRAWING

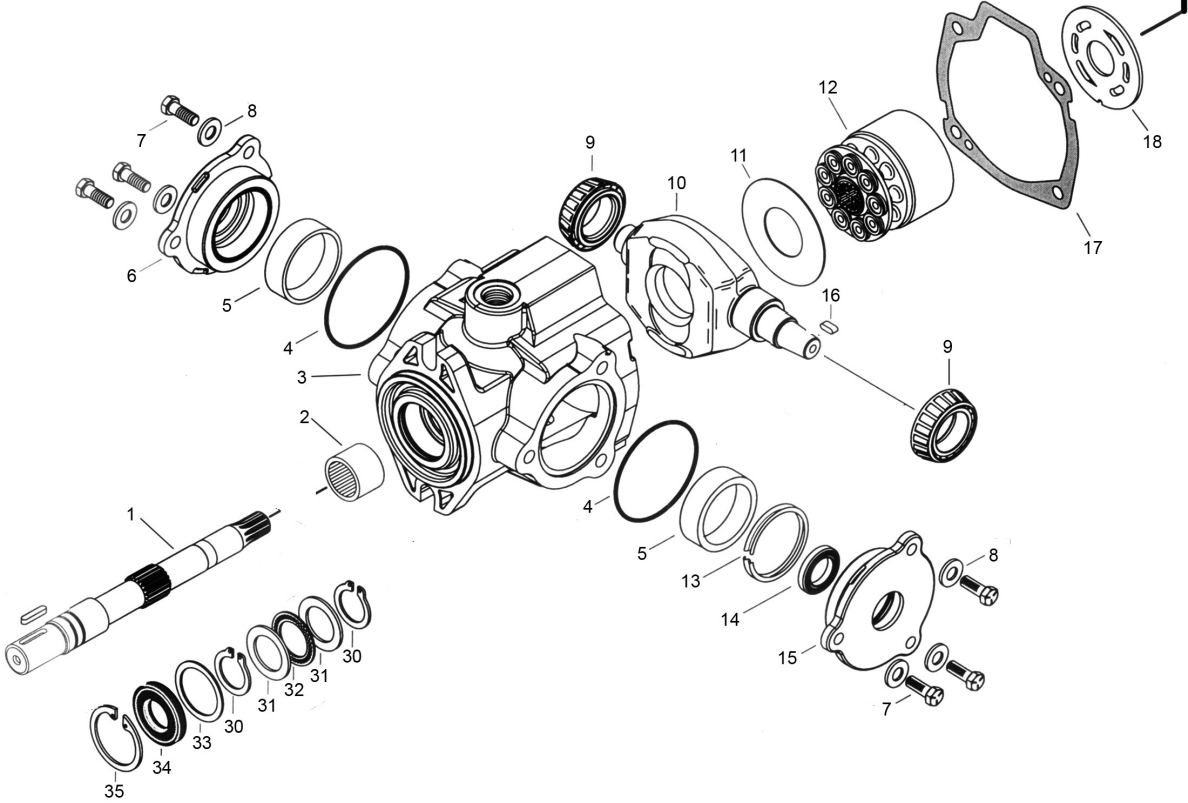
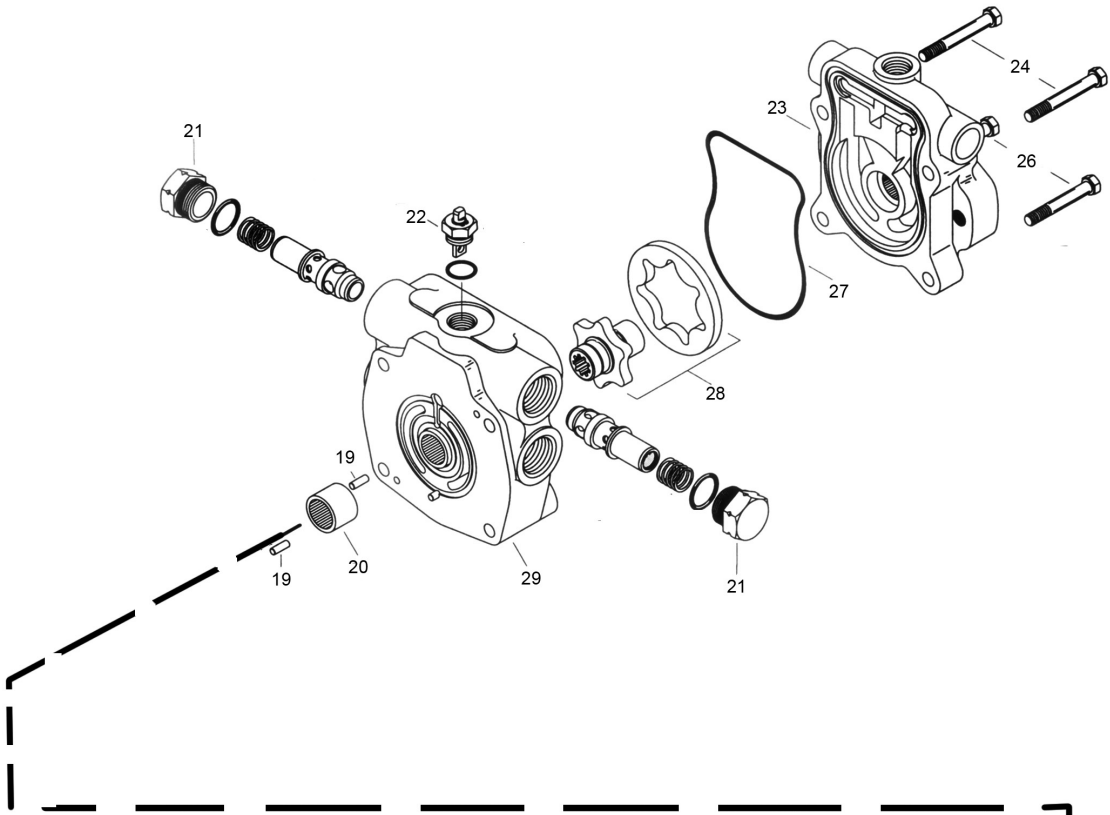

PARTS

76-638 HYDROSTATIC PUMP PARTS LIST

REF#	PART#	DESCRIPTION	QUANTITY
1	76-398-01	Drive Shaft (splined)	1
2		Needle Bearing (with housing)	1
3	77-239-01	Housing	1
4	77-239-02	O-Ring	1
5	77-239-03	Thrust Bearing	2
6	77-239-04	Trunnion Cover	1
7	77-239-05	Pan Head Screw	2
8	77-239-06	Washer	6
9	77-239-07	Cone Bearing	2
10	77-239-08	Swash Plate	1
11	77-239-09	Swash Plate Insert	1
12	60-343-21	Rotating Kit	1
13	77-239-10	Crush Ring	1
14*	60-343-12	Shaft Seal	1
15	77-239-11	Seal Cover	1
16		Key	1
17*	77-239-13	Gasket	1
18	76-482-01	Back Plate	1
19		Dowel Pin	2
20		Bearing	1
21	77-239-15	Relief Valve	2
22	77-239-16	Tow Valve Assembly	1
23		Charge Pump Adapter	1
24	77-239-17	Cap Screw	2
26	77-239-18	Cap Screw	2
27*	77-239-19	O-Ring	1
28	60-343-43	Gerotor and Coupler	1
29		End Cover Assembly	1
30*	77-239-21	Retaining Ring	2
31	60-343-05	Bearing Race	1
32	60-343-06	Thrust Bearing	1
33	60-343-03	Washer	2
34*	60-343-02	Shaft Seal	1
35*	60-343-01	Retaining Ring	1
* 	77-239-23	Seal Repair Kit	

76-638 REPAIR DISASSEMBLY INSTRUCTIONS

Disassembly

The following disassembly procedure applies to a single pump with or without gear pump. The repair procedure for tandem pumps, once they are separated, is basically the same. The basic configuration differences between a single and tandem pumps are the backplates, pump shafts and housing assemblies. In most cases, only the rear pump of tandem units contain a charge pump, which is common to both the front and rear pump. The rear tandem pump does not incorporate a shaft seal.

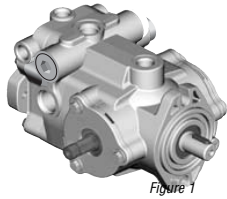

Thoroughly clean the Eaton Model 70160 or 78162 variable displacement pump before any repairs are attempted. When working on tandem pumps, separate the front and rear pumps first.

1 Support the pump with the input shaft down. Use a 1/2 in. socket or end wrench to remove the pump adapter cover plate or gear pump (see Figure 2).



2 Use a pick or similar tool to remove the adapter cover plate or gear pump o-ring. (See Figure 3)

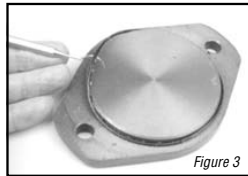

3 Use a 7/16 in. Allen wrench or bit socket remover to remove the charge pressure relief valve spring retainer from the pump adaptor assembly (see Figure 4).



4 Use a pencil magnet or similar tool to carefully remove the charge pressure spring and poppet from the pump adaptor assembly. (See Figure 5) Use caution not to drop the charge pump poppet into the pump adaptor assembly.



5 The charge pressure relief valve and poppet may be of the standard or high pressure type. The (6.9 to 10.3 bar [100 to 150 PSI]) standard spring and poppet are shown on the bottom and the optional high pressure (13.7 to 20.7 bar [200 to 300 PSI]) spring and poppet is shown on the top.

The same charge pressure relief valve spring retainer is used with either the standard or high pressure (see Figure 6).

6 Use a 7/8 in. socket or end wrench to remove the optional bypass valve assembly from the backplate (see Figure 7).



7 The internal seal may be replaced by first removing the small retaining ring on the end of the bypass valve. Remove and replace the o-rings (see Figure 8).

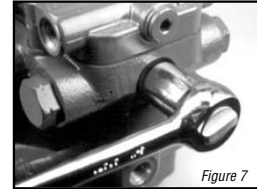

8 Use a 9/16 in. hex key to remove the two high pressure relief valves from the pumps backplate assembly (see Figure 9). Remove relief valve as shown from each side (see Figure 10). Each system relief valve S/A is identified by both its part number and relief valve setting as shown in Parts Information manual.

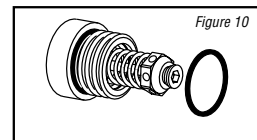
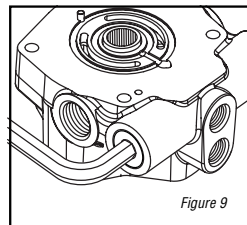
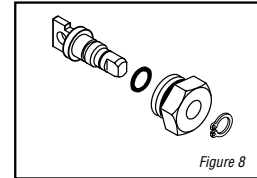

9 Firmly support the pump assembly. Use a 1/2 in. socket or end wrench to remove the four cap screws retaining the charge pump adaptor assembly.

10 With the cap screws removed, remove the charge pump adaptor assembly from the backplate (see Figure 11).

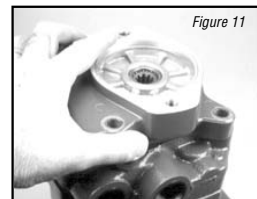

Note: The front pump assemblies do not have charge pump adaptor assemblies.

11 Turn the adapter assembly over. Use an o-ring pick or similar tool remove the o-ring seal (see Figure 12).



12 Inspect the gerotor pocket and needle bearing located in the charge pump adapter. The needles in the needle bearing must remain intact in the bearing cage.

13 When the needle bearing assembly is replaced, the numbered end of the bearing must face toward the flange side of the adapter to the dimension as shown (see Figure 13).

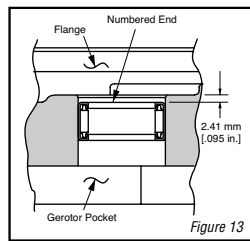

14 With the charge pump adapter removed, remove the charge pump outer ring and inner gerotor ring assembly (see Figure 14 and 15).

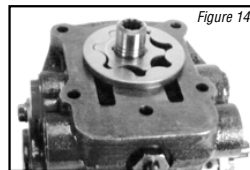

15 Charge pumps are available in two different displacements. Charge pump displacements are based on the thickness of the gerotor assembly and the depth of the pocket located in the charge pump adapter. To determine the displacement, refer to the table below.

Gerotor Pocket Depth

Displacement cm ³ /r [in ³ /r]	Depth of Pocket mm [in.]
6.9 [.42]	6.35 [.25]
13.8 [.84]	12.7 [.50]

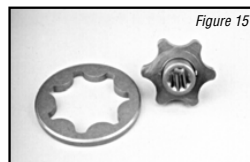

16 To separate the backplate assembly from the dowel pins in the pump housing assembly, insert two screwdrivers between backplate and housing assembly and pry upward (see Figure 16).

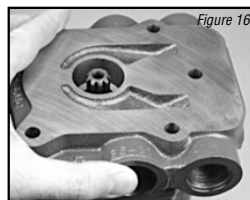

17 After separation, remove the backplate from the housing assembly.

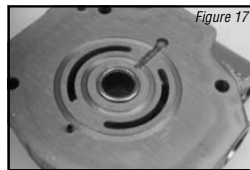

18 Turn the backplate assembly over and inspect the needle bearing. The needles in the needle bearing must remain intact in the bearing cage (see Figure 17).

19 When the needle bearing assembly is replaced, the numbered end of the bearing must face the valve plate side of the backplate to the dimension as shown (see Figure 18).

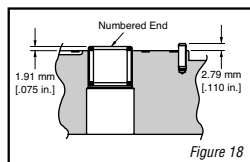

20 With the backplate removed, remove the gasket from the pump housing assembly and discard (see Figure 19).



21 Remove the valve plate from the piston block assembly. Note: This valve plate may have stuck to the backplate assembly that was previously removed.

22 Valveplate directional rotation (CW or CCW) is identified by the location of the metering slots located on the face of the valve plates. Pump input rotation should always turn into the metering slots (see Figure 20). A clockwise valve plate is shown on the left and a counter clockwise valveplate is on the right.

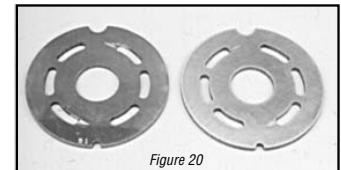

Note: Whenever pump input rotation is changed, the valve plate must be replaced along with the desired rotation charge pump adapter.

23 Remove the rotating kit assembly by carefully retaining it in the housing assembly (see Figure 21). Lift the housing and rotating kit assembly and turn over assemblies allowing the rotating kit assembly to slide down the input shaft and out of the pump housing.

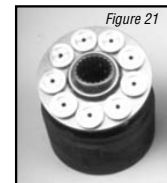

24 With the rotating kit assembly removed, remove the piston assemblies, spider and spider pivot from the piston barrel. (see Figure 22).



25 Inspect the piston assemblies, spider, spider pivot and piston block. The piston block assembly usually requires no further disassembly unless the pins or block spring are damaged.

26 When any excessive wear or scratches are noted on the face of the piston block, the block assembly must be replaced (see Figure 23).



DO NOT LAP THE FACE OF PISTON BLOCK ASSEMBLY.

27 To remove the input shaft assembly, use a pair of internal snap ring pliers and remove the shaft seal retaining ring from the housing assembly (see Figure 24).



76-638 REPAIR DISASSEMBLY INSTRUCTIONS

28 With the retaining ring removed, use a small press to press the shaft seal and input shaft assembly from the housing assembly.

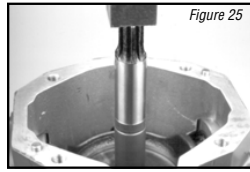

29 With the input shaft assembly removed, disassemble the assembly for inspection by removing the shaft seal, washer, retaining ring thrust washers and bearing (see Figure 26).



Note: The rear pump on tandem units uses a spacer in place of shaft seals.

30 To remove the camplate from the housing assembly, use a 9/16 in. socket or end wrench and remove the three cap screws and washers retaining the control arm cover plate assembly. Start at the cover plate with control arm (see Figure 27).

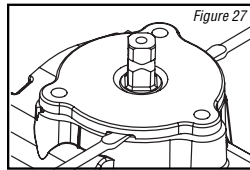

31 With the retaining cap screws removed, insert two small screwdrivers in the notches located in the cover plate assembly and pry upward. Make sure bearing cup comes off with the cover plate (see Figure 28).

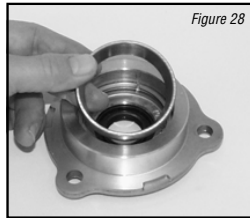

Note: The crush ring in the control arm trunnion cover does not need to be removed (see Figure 29). The only time the crush ring needs to be removed is when either the trunnion cover, the camplate assembly or the housing assembly is replaced. A shim kit is then required in the crush ring's place.

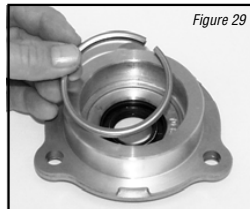

32 Reposition the pump assembly to remove opposite cover plate. The bearing cup in this cover plate is press fit and not removable. Repeat steps 30 through 31.

32b Remove the slip fit bearing on the non-control arm side of the camplate.

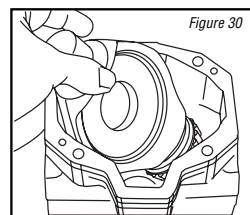

33 With housing in the upright position, slide the camplate toward the control side and lift it from the pump housing (see Figure 30).

Note: The camplate control shaft will fit out either side of the pump housing. Be sure to note on which side of the housing the control shaft protrudes before removing camplate from

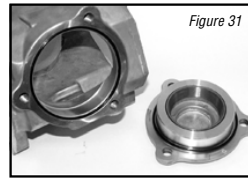

34 Use an o-ring pick or similar tool to remove the o-ring seals from the two counter-bores in the housing or the cover plates (see Figure 31).

35 To remove the control side cover plate lip seal, use a small press and press the lip seal inward (see Figure 32).

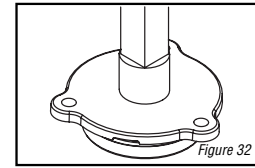

36 Remove the thrust plate from the camplate. The thrust plate is reversible and either side may face the camplate (see Figure 33).



37 Inspect the housing assembly's front needle bearing. If the needles remain in their cage and move freely, replacement usually is not required (see Figure 34).

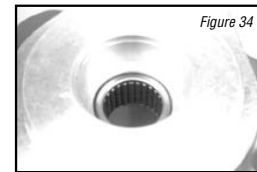

38 When the needle bearing is replaced, the numbered end of the needle bearing must face away from the housing and pressed to the dimension as shown (see Figure 35).

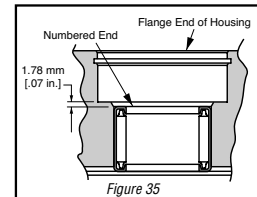

Reassembly

1 Before reassembling the pump, replace all worn and damaged parts, assemblies, seals and o-rings. Lubricate the seals and o-rings with petroleum jelly to help retain them during reassembly and to provide lubrication to the input and control shaft seals. Lubricate all finished part surfaces freely with clean hydraulic fluid to help provide start up lubrication between all rotating parts.

2 To reassemble the camplate assembly into the pump housing, tilt the camplate slightly and install the control side of the camplate through the previously noted or marked side of the housing assembly (see Figure 36).

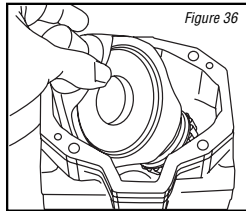

3 Lubricate the tapered bearing and reassemble it on the non-control arm side of the camplate (see Figure 37).

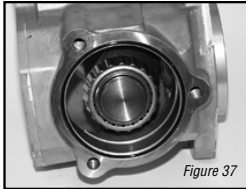

4 Lubricate and install the o-ring seal into counter-bore of housing (see Figure 37).

5 Install the trunnion cover over bearing and onto pump housing. Install the three cap screws and washers, torque screws to 39,3 Nm [29 ft-lb] (see Figure 38).

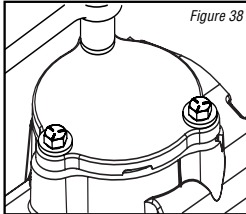

6 Lubricate and install the control arm shaft seal into the control arm cover plate. Install with the lip of the seal facing upward or to the inside of the pump (see Figure 39).

7 If the housing, trunnion covers or camplate assembly have not been replaced, the existing crush ring may be re-used. If you have replaced anyone of the above a shim kit must replace the crush ring. See Parts Information manual for number.

8 Place the bearing cup into trunnion cover over the crush ring or shims (see Figure 40).

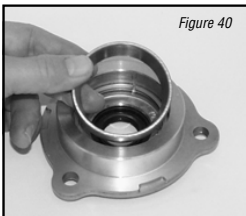
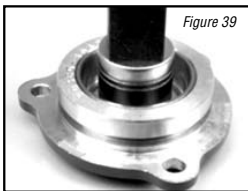

9 Lubricate and install the o-ring seal into counter-bore of housing (see Figure 41).

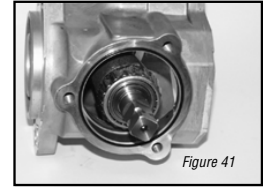

10 Install the trunnion cover over the control shaft and into the pump housing. Install the three retaining cap screws and washers, torque screws to 39,3 Nm [29 ft-lb] (see Figure 42).

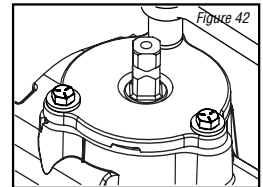

11 Using your fingers, tilt the camplate back and forth to check the trunnion bearing preload. Proper preload is achieved when the camplate has a very slight tilting resistance. The camplate must not have any or very little side clearance.

12 Reassemble the input shaft assembly by installing the thrust washer, thrust bearing, second thrust washer, retaining ring, washer and shaft seal (see Figure 43).



Note: The lip of the shaft seal must point toward the center of the input shaft.

13 Install the input shaft assembly into the housing assembly. Push the shaft seal in just far enough so you can start the shaft seal retaining ring.

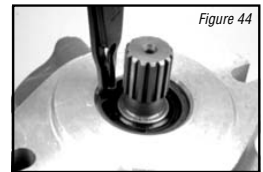

14 Use a pair of snap ring pliers to install retaining snap ring into the housing assembly (see Figure 44).

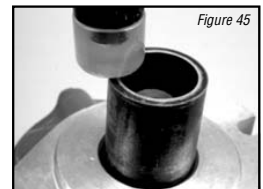

15 Use a seal driver or similar tool to press or drive the snap ring and seal into the housing assembly (see Figure 45).

CAUTION! Press or drive inward until the snap ring snaps into the snap ring groove located in the pump housing assembly.

16 The thrust plate is reversible. Either side will fit into the camplate. In most cases if any irregularities are noted it is best to replace the thrust plate (see Figure 46).

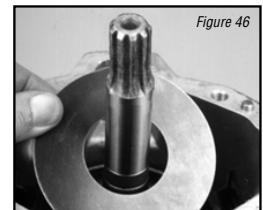

76-638 REPAIR REASSEMBLY INSTRUCTIONS

18 Lubricate and install the thrustplate over the input shaft assembly and into the camplate. The thrustplate must rest firmly in its pocket located in the camplate.

19 Reassemble the rotating kit assembly by first aligning the splines in the pivot with the splines in the block. Install the pivot on the block assembly pins (see Figure 47).

20 Use a small socket or similar tool to help retain the pivot in the centered position. Lubricate and install the spider and piston assemblies onto the pivot and pistons into the piston block assembly (see Figure 48).

21 Hold the housing assembly in the vertical position then carefully install the rotating kit by first aligning with the splines on the input shaft. With splines aligned, install the rotating kit into the pump housing (see Figure 50). Use caution to ensure all parts are kept in their proper position.

22 With the rotating kit installed, reposition the housing assembly in the input shaft down position and install a new housing gasket (see Figure 50).

23 Lightly coat the backplate side of the valve plate with petroleum jelly for retention during assembly. Install the valve plate over the needle bearing, aligning the small slot on the outside of the valve plate with the dowel pin in the backplate (see Figure 51).

24 Carefully install the backplate assembly by aligning it with the dowel pins located in the pump housing. Use caution not to dislodge the valve plate (see Figure 54).

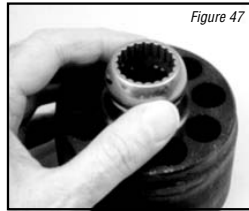

Figure 47



Figure 48

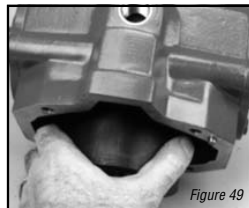

Figure 49

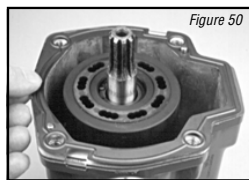

Figure 50

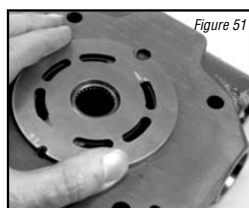

Figure 51

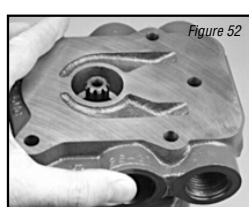

Figure 52

25 Align the spline of the gerotor's inner ring, then lubricate and install the inner ring and outer ring over the input shaft and onto the backplate assembly (see Figure 53).

Note: Before installing the charge pump adaptor plate, offset the outer ring of the gerotor as shown.

26 With the gerotor assembly installed, install new o-ring into charge pump adapter plate and place adapter onto backplate over gerotor. Retain with cap screws. Torque cap screws to 25 N•m [18.5 lbf•ft] (see Figure 54).

27 Install the two high pressure relief valves. Torque valves 128,8 to 142,4 Nm [95 to 105 lb-ft] (see Figure 55).

29 Lubricate and reassemble the bypass valve assembly. Install the bypass valve into the backplate. Torque valve to 30,5±2 Nm [22.5±1.5 lb-ft] (see Figure 56).

30 Coat the charge pressure poppet with petroleum jelly and place poppet onto spring and install into the adapter plate (see Figure 57).

31 Install the hollow charge pressure relief valve retainer into the adapter plate. Torque retainer to 6,8 to 9,5 Nm [5 to 7 lb-ft].

32 Lubricate and install the o-ring on the cover plate or gear pump. Install the cover plate or gear pump and two cap screws. Torque cap screws to 36,6 to 40 Nm [27 to 31 lb-ft].

The Model 70160 or 78162 variable displacement pump is now ready for test and reinstallation.

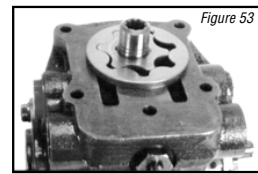

Figure 53

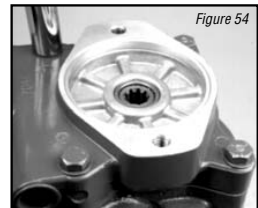

Figure 54

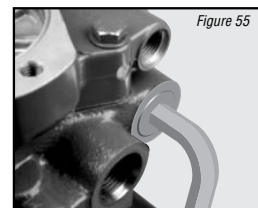

Figure 55

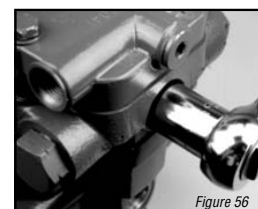

Figure 56



Figure 57

This fault - logic troubleshooting guide is a diagnostic aid in locating transmission problems.

Match the transmission symptoms with the problem statements and follow the action steps shown in the box diagrams. This will provide help in correcting minor problems eliminating unnecessary machine down time.

Following the fault - logic diagrams are diagram action comments of the action steps shown in the diagrams. Where applicable, the comment number of the statement appears in the action block of the diagrams.

Explanatory Diagram

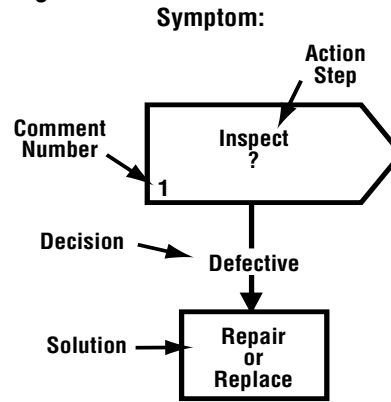

Recommended Gauge Locations

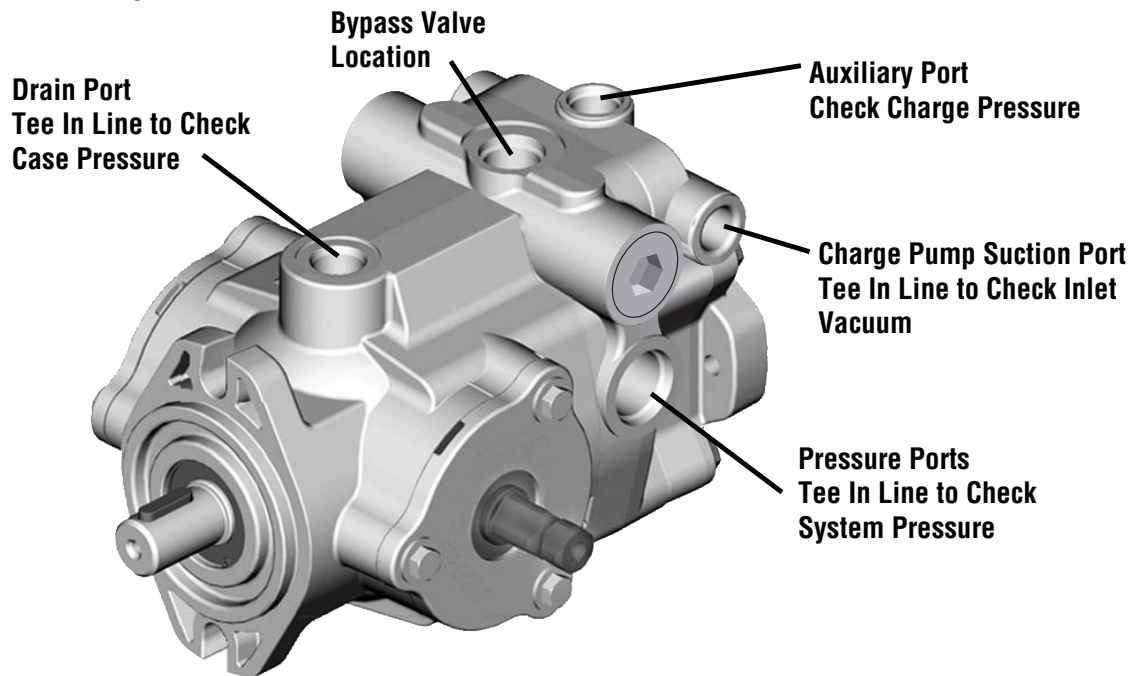

Figure 58

Gauges Recommended

Inlet vacuum gauge: 2 bar to 1 bar [30 PSI to 30 inHg]

System pressure gauge: 700 bar [10,000 PSI]

Charge pressure gauge: 0 to 50 bar [0 to 600 PSI]

Case pressure gauge: 0 to 25 bar [0 to 300 PSI]

Symptom: Neutral Difficult or Impossible to Find

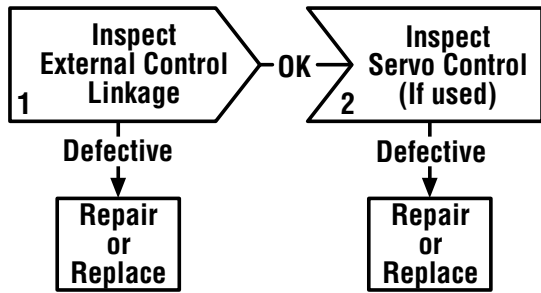

Symptom: System Operating Hot

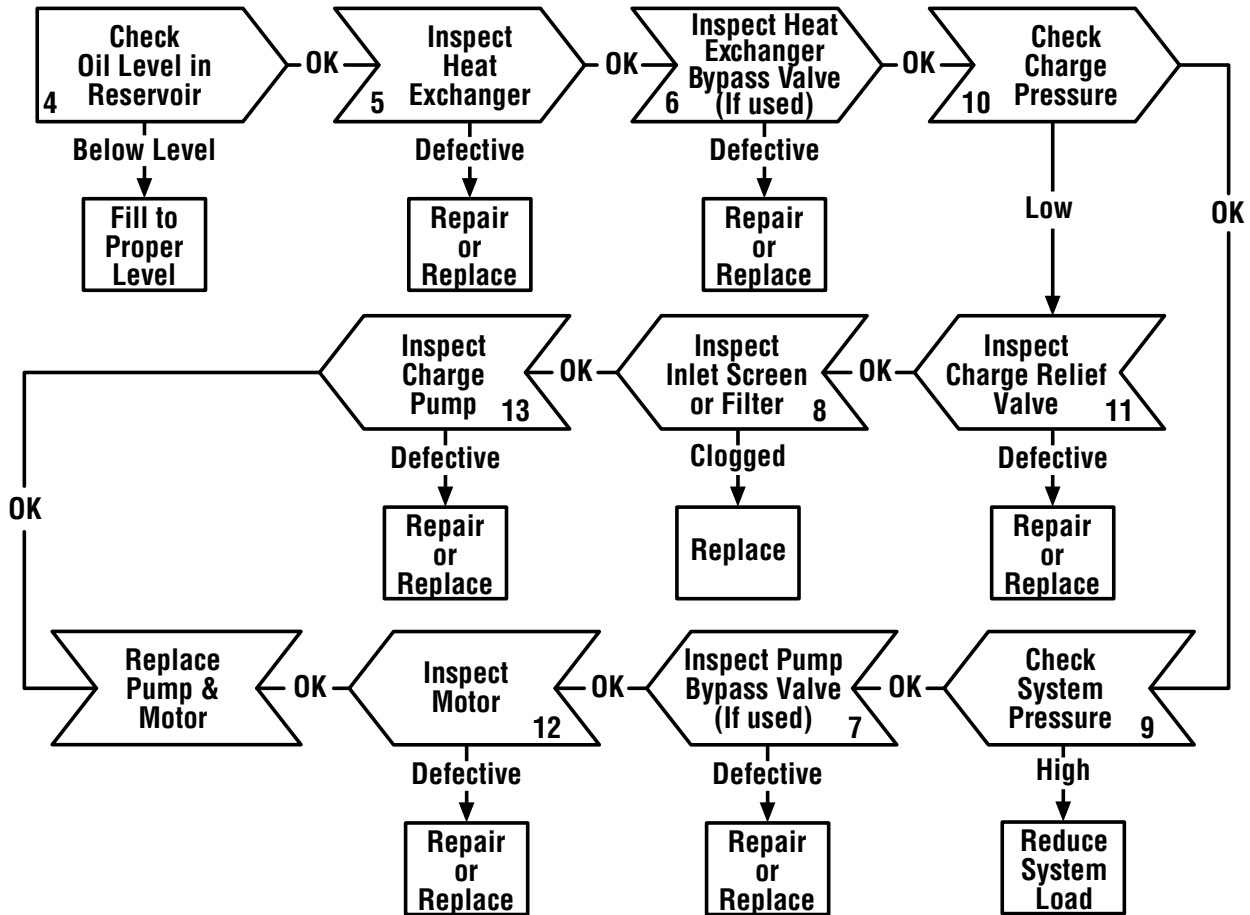

PARTS

Symptom: Operates in One Direction Only

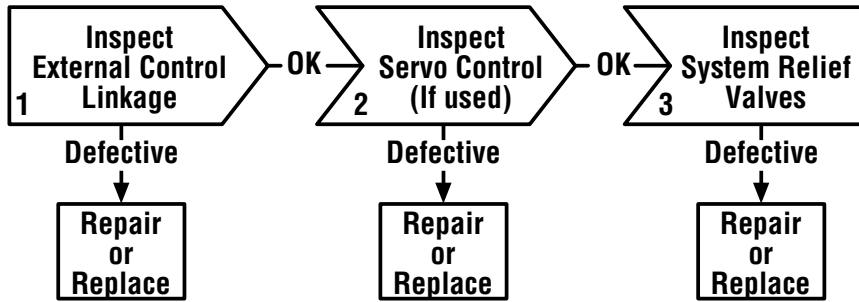

Symptom: System Response Sluggish

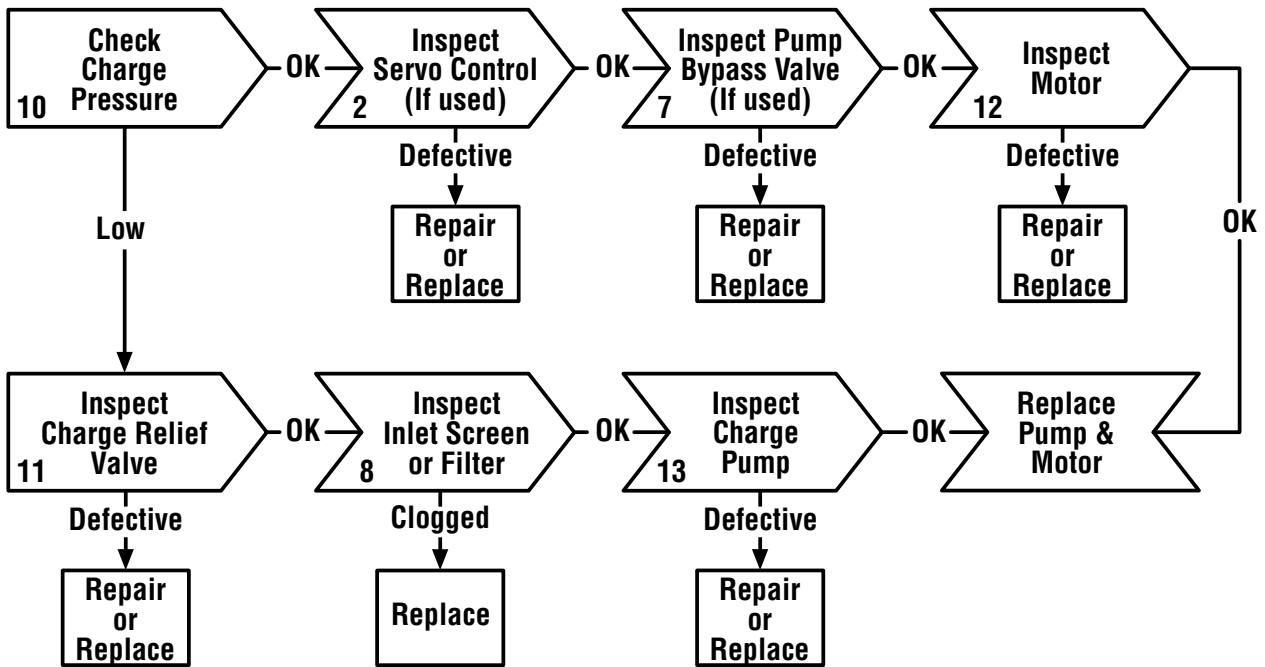

Parts

Symptom: System Will Not Operate In Either Direction

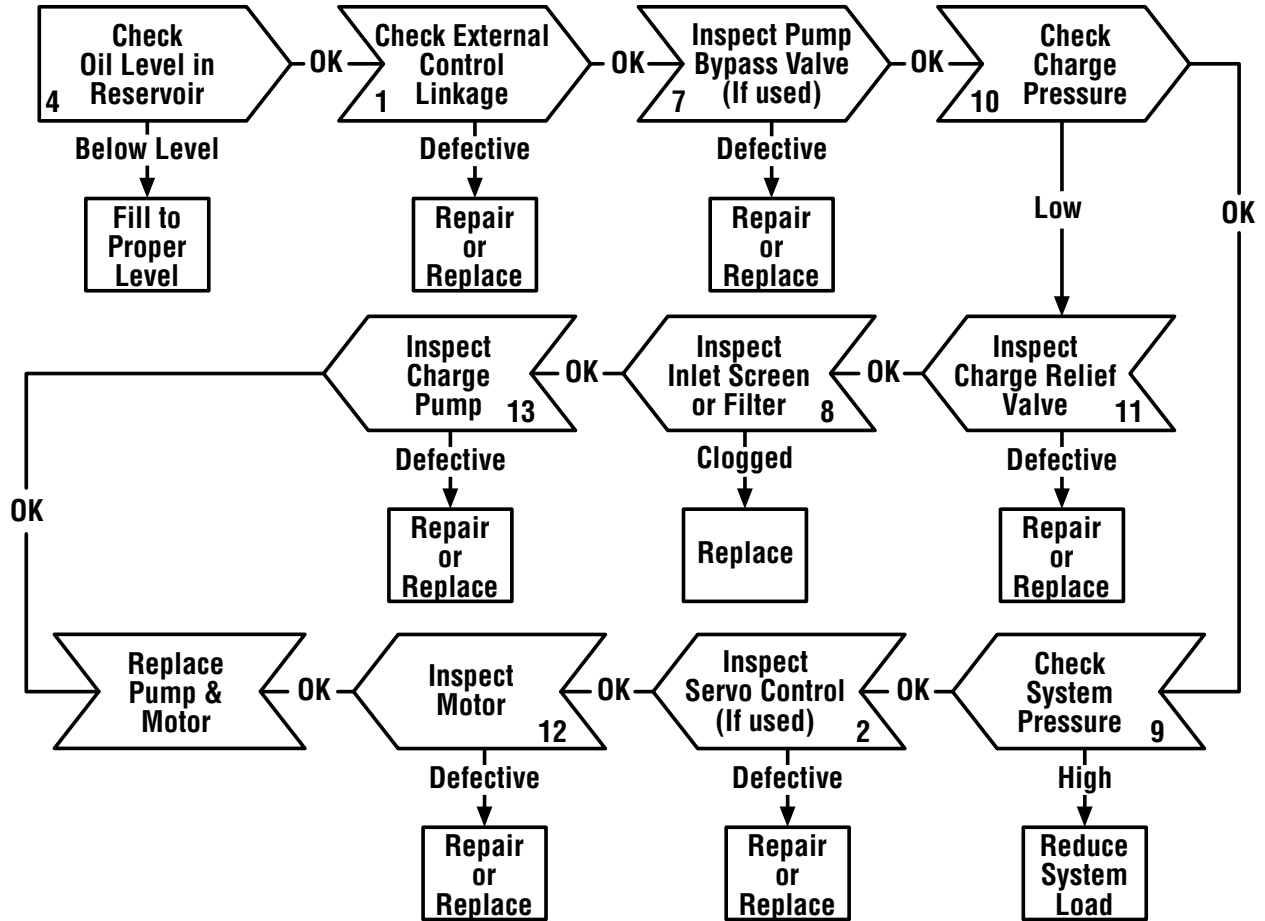

Diagram Action Step Comments

- 1 Inspect External Control Linkage for:**
 - a. misadjustment or disconnection
 - b. binding, bending or breakage
 - c. misadjusted, damaged or broken neutral return spring
- 2 Inspect Servo Control Valve for: (if used)**
 - a. proper inlet pressure
 - b. misadjusted, damaged or broken neutral return spring
 - c. galled or stuck control spool
 - d. galled or stuck servo piston
- 3 Inspect System Relief Valves* for:**
 - a. improper pressure relief setting
 - b. damaged or broken spring
 - c. valve held off seat
 - d. damaged valve seat
- 4 Check Oil Level in Reservoir:**
 - a. consult owner/operators manual for the proper type fluid and level
- 5 Inspect Heat Exchanger for:**
 - a. obstructed air flow (air cooled)
 - b. obstructed water flow (water cooled)
 - c. improper plumbing (inlet to outlet)
 - d. obstructed fluid flow
- 6 Inspect Heat Exchanger Bypass Valve for: (if used)**
 - a. improper pressure adjustment
 - b. stuck or broken valve
- 7 Inspect Pump Bypass Valve for: (if used)**
 - a. held in a partial or full open position
- 8 Inspect Inlet Screen or Filter for:**
 - a. plugged or clogged screen or filter element
 - b. obstructed inlet or outlet
 - c. open inlet to charge pump
- 9 Check System Pressure:**
 - a. See figure 60 for location of pressure gauge installation.
 - b. consult owner/operators manual for maximum system relief valve settings
- 10 Check Charge Pressure:**
 - a. See figure 60 for location of pressure gauge installation.
 - b. consult owner/operators manual for maximum charge relief valve settings

- 11 Inspect Charge Relief Valve for:**
 - a. improper charge relief pressure setting *
 - b. damaged or broken spring
 - c. poppet valve held off seat
- 12 Inspect Motor for:**
 - a. disconnected coupling
- 13 Inspect Charge Pump for:**
 - a. broken or missing drive key
 - b. damaged or missing o-ring
 - c. excessive gerotor clearance
 - d. galled or broken gerotor set

* System/Charge Relief Valve Pressure Settings for Eaton's Variable Displacement Controlled Piston Pumps

Inlet Vacuum	6 inHg max.
Case Pressure	25 PSI maximum
Charge Pressure	100 to 150 PSI Standard 200 to 250 PSI Optional 250 to 300 PSI Optional
System Pressure	5000 PSI maximum 3000 PSI continuous

The high pressure relief valves are all factory preset and cannot be readjusted.

The pressure setting and assembly number is stamped on each high pressure relief valve cartridge.

Valve Identification Example:

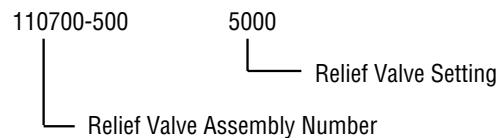

76-638 START-UP PROCEDURE

When starting a new or rebuilt transmission system, it is extremely important to follow the start-up procedure. It prevents the chance of damaging the unit which might occur if the system was not properly purged of air before start-up.

- 1 After the transmission components have been properly installed, fill the pump housing at least half full with filtered system oil. Connect all hydraulic lines and check to be sure they are tight.
- 2 Install and adjust all control linkage.
- 3 Fill the reservoir with an approved oil that has been filtered through a 10 micron filter. Refer to Eaton Hydraulics Technical Data Sheet number 3-401 titled [Hydraulic Fluid Recommendations](#).
- 4 For Gasoline engines or L.P. engines remove the coil wire and turn the engine over for 15 seconds. For Diesel engines shut off the fuel flow to the injectors and turn the engine over for 15 seconds.
- 5 Replace the coil wire or return the fuel flow to the injectors. Place the transmission unit in the neutral position, start the engine and run it at a low idle. The charge pump should immediately pick up oil and fill the system. If there is no indication of fill in 30 seconds, stop the engine and determine the cause.

- 6 After the system starts to show signs of fill, slowly move pump camplate to a slight cam angle. Continue to operate system slowly with no load on motors until system responds fully.
- 7 Check fluid level in the reservoir and refill if necessary to the proper level with an approved filtered oil.
- 8 Check all line connections for leaks and tighten if necessary.

The machine is now ready to be put into operation.

Frequent filter changes are recommended for the first two changes after placing the machine back into operation. Change the first filter in 3-5 hours and the second in approximately 50 hours. Routinely scheduled filter changes are recommended for maximum life of the hydraulic system.

76-197 EATON GEAR PUMP DRAWING

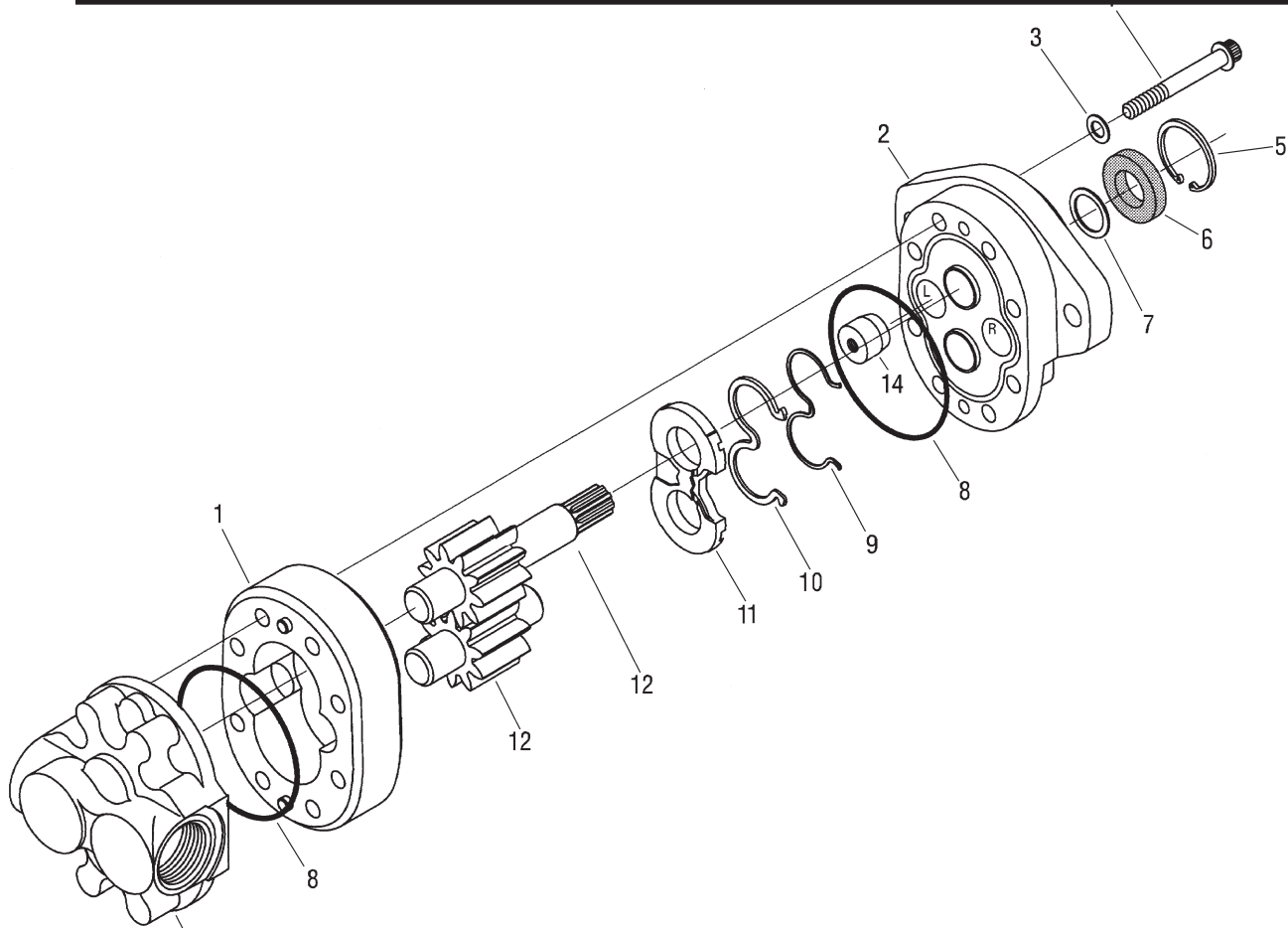

REF#	PART#	DESCRIPTION	QUANTITY
1		Body	1
2	76-197-01	Front Plate	1
3*		Washer	4
4	76-197-06	Cap Screw	8
5	76-197-07	Retaining Ring	1
6*		Shaft Seal	1
7	33-061-15	Washer	1
8*		O-Ring	2
9*		Backup Gasket	1
10*		Seal	1
11*		Wear Plate	1
12	76-197-04	Shaft (comes with Idler Gear)	1
13	76-197-02	Back Plate	1
14*		Plug	1
*	76-197-08	Seal Kit	

76-197 REPAIR DISSASSEMBLY INSTRUCTIONS

Repair Information - Model 26000

Work in a clean area; cleanliness is extremely important when repairing hydraulic pumps. Before disconnecting the lines, clean port area of pump. Disconnect hydraulic lines, removing pump assembly from vehicle and plugging ports. Thoroughly clean the outside of pump. After cleaning, remove port plugs and drain oil.

Disassembly

- 1 Remove *key* from drive shaft if keyed drive gear assembly is used.
- 2 Put a *location mark* across front plate, body and backplate to assure proper reassembly.
- 3 Clamp pump in vise, shaft end up.
- 4 Remove *cap screws* (eight each) and washer (four each).
- 5 Remove pump from vise, hold pump in hands and tap shaft with plastic hammer or rawhide mallet to separate front plate from backplate. Body will remain with either front plate or backplate.

- 6 Remove *o-ring* seal from backplate.

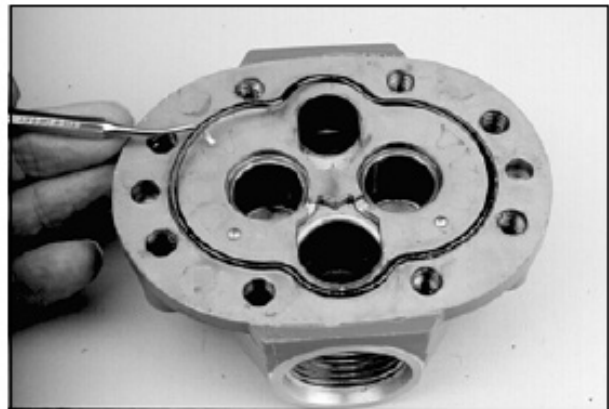

7. Remove backplate.



76-197 REPAIR DISASSEMBLY INSTRUCTIONS

8 Remove *idler gear assembly* from body.

9 To separate *body* from the plate it remained with, place *drive gear assembly* in gear pocket and tap protruding end with plastic hammer or rawhide mallet. Remove drive gear assembly.

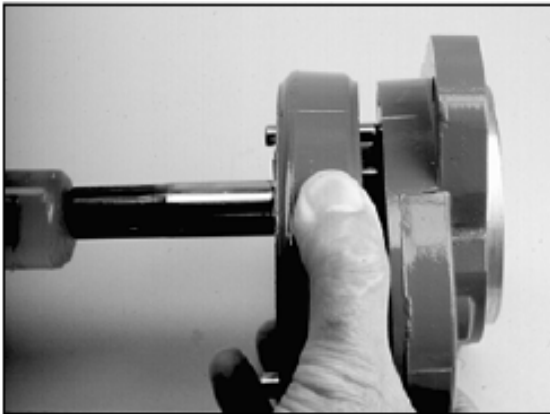

10 Remove wear plate and o-ring seal, noting position of open side of wear plate.

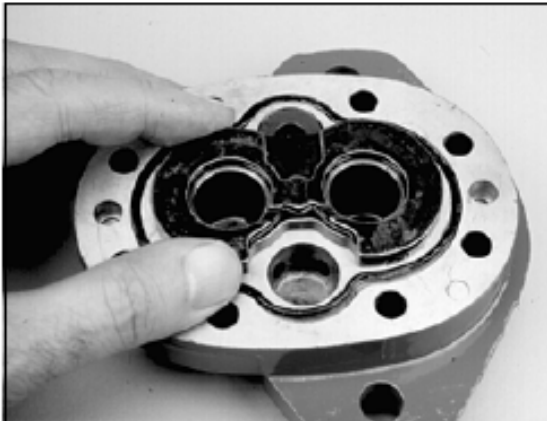

11 Remove *back-up gasket and seal* from wear plate by extracting with a o-ring tool.



12 Remove snap ring (if applicable) from the front of the front plate shaft seal area.

13 Remove *shaft seal and washer* from front plate with a blunt punch from the back side.

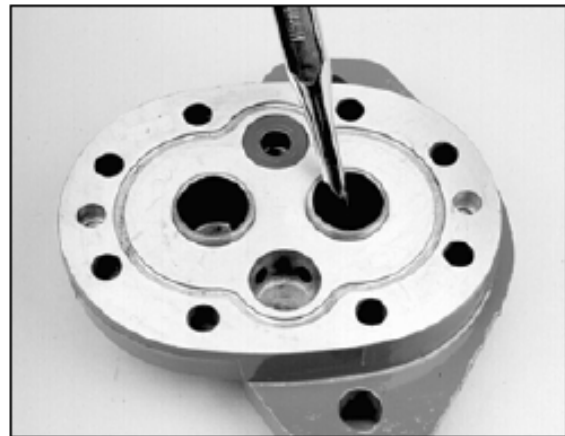

14 Removing the *plug* in front plate is not necessary, unless you intend to change rotation. See Reversibility - Changing Input Rotation of Pump.

15-970 HYPRO PUMP DRAWING

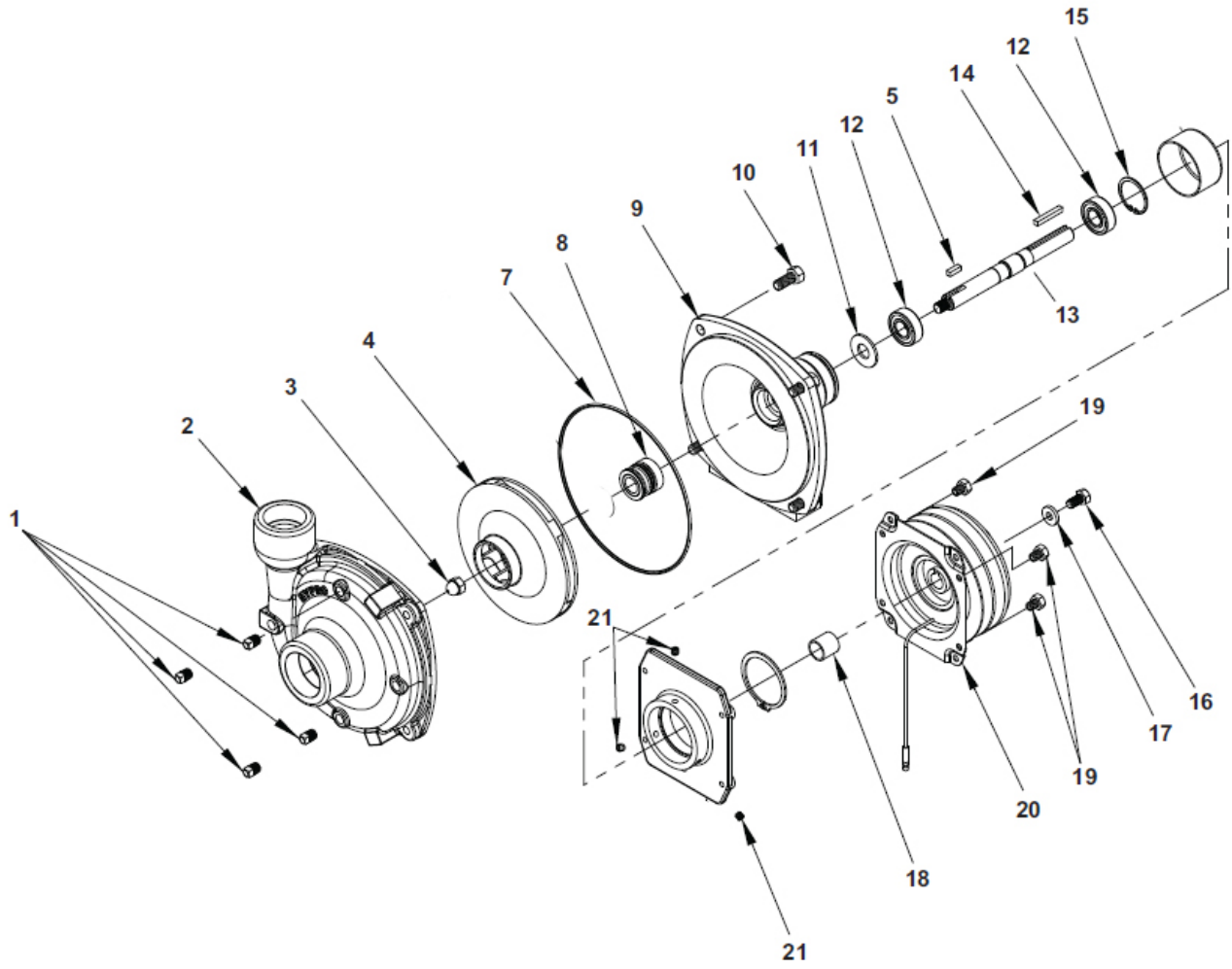

PARTS

15-970 HYPRO® PUMP PARTS LIST

REF#	PART#	DESCRIPTION	QUANTITY
1	16-998-01	Drain Plug	4
2	16-998-02	Pump Casing	1
3		Impeller Nut	1
4	16-966-16	Impeller	1
5	16-966-11	Key	1
7*	16-998-04	O-Ring	1
8*	16-967	Mechanical Seal (Silicon Carbide)	1
9	16-998-06	Mounting Flange	1
10	16-998-07	Bolt	
11	16-966-06	Slinger Ring	1
12	16-966-10	Ball Bearing	2
13	16-966-12	Pump Shaft	1
14	16-822-20	Key	1
15	16-966-13	Bearing Retainer	1
16	16-994-05	Bolt	1
17	16-994-06	Retaining Washer	1
18	16-994-03	Spacer	1
19		Bolt	4
20	16-994-01	Clutch	1
21	16-994-04	Set Screw	3
	16-998-12	Pump Only	
*	16-967	Silicone - Carbon Seal Kit	

When servicing the spray pump or filter, all control valves must be shut off if there is liquid in the tank.

 **IMPORTANT**

1201 PLUMBING DRAWING (MANUAL SYSTEM)

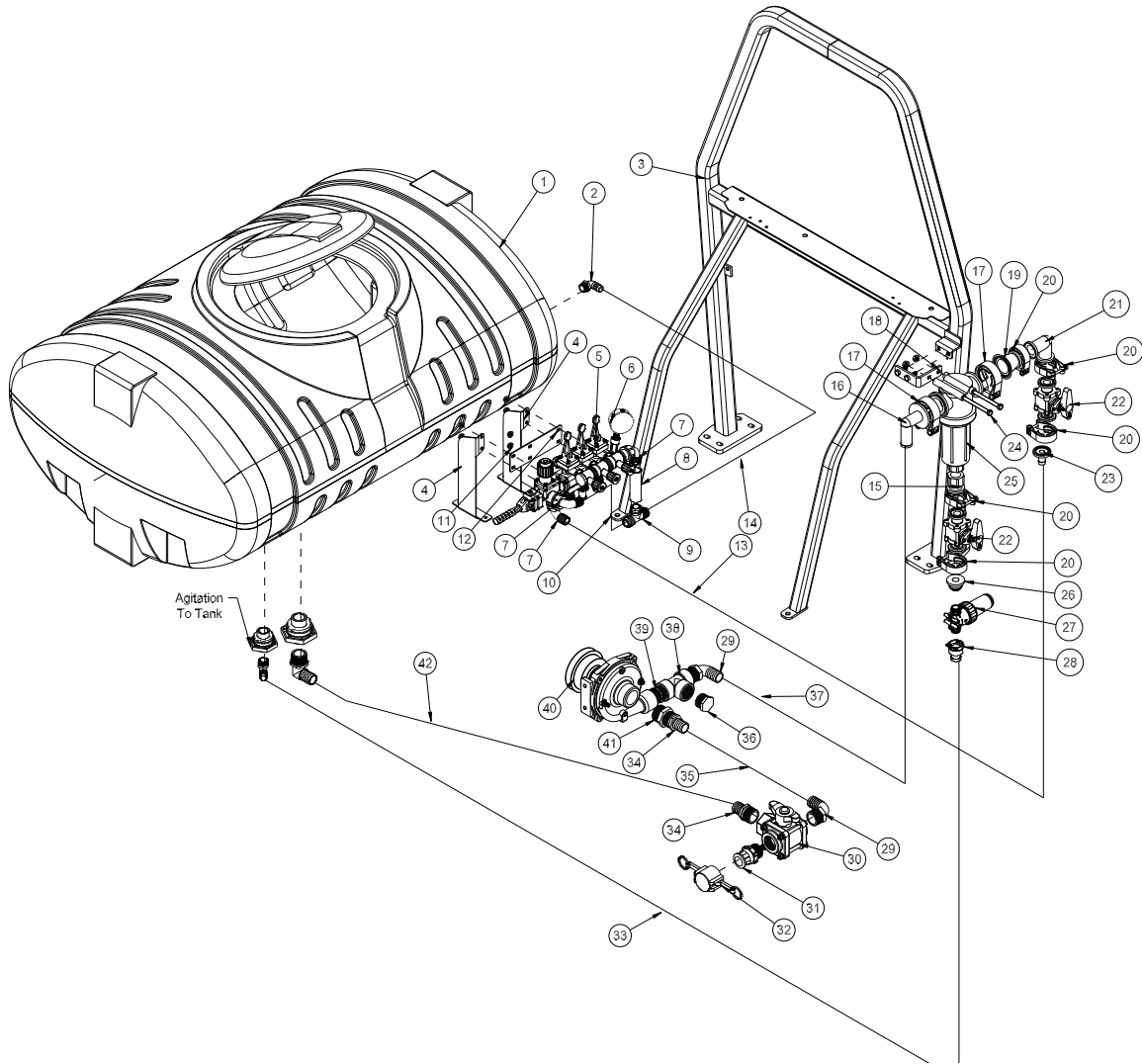

REF#	PART#	DESCRIPTION	QUANTITY
1	20-802	200 Gallon Poly Tank	1
2	16-153	Elbow	1
3	15-922	Roll Bar	1
4	10-646	Ball Valve Mount Bracket	2
5	10-648	Valve 3-Way	1
6	16-281	Liquid Filled Gauge	1
7	10-268-13	90° Elbow (comes with 10-268)	3
	9032-153	3/4" Black Hose x 153"(right and left)	2
	9032-114	3/4" Black Hose x 114"(center)	1
	18-040	Hose Clamp	6
8	8896-4	Discharge Hose 1"	1
	18-222	Hose Clamp	2
9	10-269	Plastic Tee	1
10	8896-12	Discharge Hose 1" x 12"	1
	18-222	Hose Clamp	2

1201 PLUMBING PARTS LIST (MANUAL SYSTEM)

REF#	PART#	DESCRIPTION	QUANTITY
11	HB-516-18-075	Bolt $\frac{5}{16}$ - 18 x $\frac{3}{4}$	6
	HNFL-516-18	Flange Lock Nut, $\frac{5}{16}$ - 18	6
12	10-647	Mount Plate	1
13	8896-40	Discharge Hose 1"	1
	18-222	Hose Clamp	2
14	8896-22	Discharge Hose 1"	1
	18-222	Hose Clamp	2
15	15-735	50 Series 1 FPT	1
16	15-739	75 Series 90° x $1\frac{1}{4}$ Hose Barb	1
17	15-741	75 Series Clamp	2
18	15-904	Filter Mount	1
	HB-38-16-100	Bolt, $\frac{3}{8}$ - 16 x 1	2
	HNFL-38-16	Flange Lock Nut, $\frac{3}{8}$ - 16	2
19	15-748	Reducer Coupling	1
20	15-740	50 Series Clamp	5
21	15-736	50 Series Elbow Coupling	1
22	15-738	Flanged Ball Valve	2
23	15-808	Hose Barb Flange	1
24	HB-38-16-500	Bolt, $\frac{3}{8}$ - 16 x 5	2
	HNFL-38-16	Flange Lock Nut, $\frac{3}{8}$ - 16	2
25	15-737	Flanged Strainer	1
	15-780	$\frac{1}{4}$ " Poly Plug	1
26	15-825	QC Flange Adapter	1
27	14-801	Agitation Strainer, 50 mesh	1
	14-802	50 Mesh Screen	
	14-803	Decal, Clean Strainer	1
28	15-869	Hose Barb Outlet	1
29	16-156	Elbow $1\frac{1}{4}$ MPT x $1\frac{1}{4}$ HB	3
30	18-372	3-Way Ball Valve	1
	18-372-01	T-Handle	1
31	16-180	Quick Coupler $1\frac{1}{4}$ Male	1
32	16-935	Quick Coupler $1\frac{1}{4}$ Cap	1
33	8896-68	Discharge Hose 1"	1
	18-222	Hose Clamp	2
34	16-161	Fitting $1\frac{1}{4}$ NPT x $1\frac{1}{4}$ HB	2
35	8897-19	Discharge Hose $1\frac{1}{4}$ x 26"	1
	18-116	Hose Clamp	2
36	10-389	Plug $1\frac{1}{4}$	1
37	8897-70	Discharge Hose $1\frac{1}{4}$ "	1
	18-116	Hose Clamp, HS-24	2
38	18-390	Pipe Tee $1\frac{1}{4}$	1
39	16-880	Nipple	1
40	16-998	Hypro® Pump	1
41	16-825	Reducer	1
42	8897-32	Discharge Hose $1\frac{1}{4}$ "	1
	18-116	Hose Clamp	2

BOOM	LEFT HOSE	CENTER HOSE	RIGHT HOSE
15"	9032-125	9032-90	9032-136
18'	9032-125	9032-90	9032-136
20'	9032-135	9032-90	9032-146

1202 PLUMBING DRAWING (RADION® 8140)

15-818 #75 Fitting Oring

15-817 #50 Fitting Oring

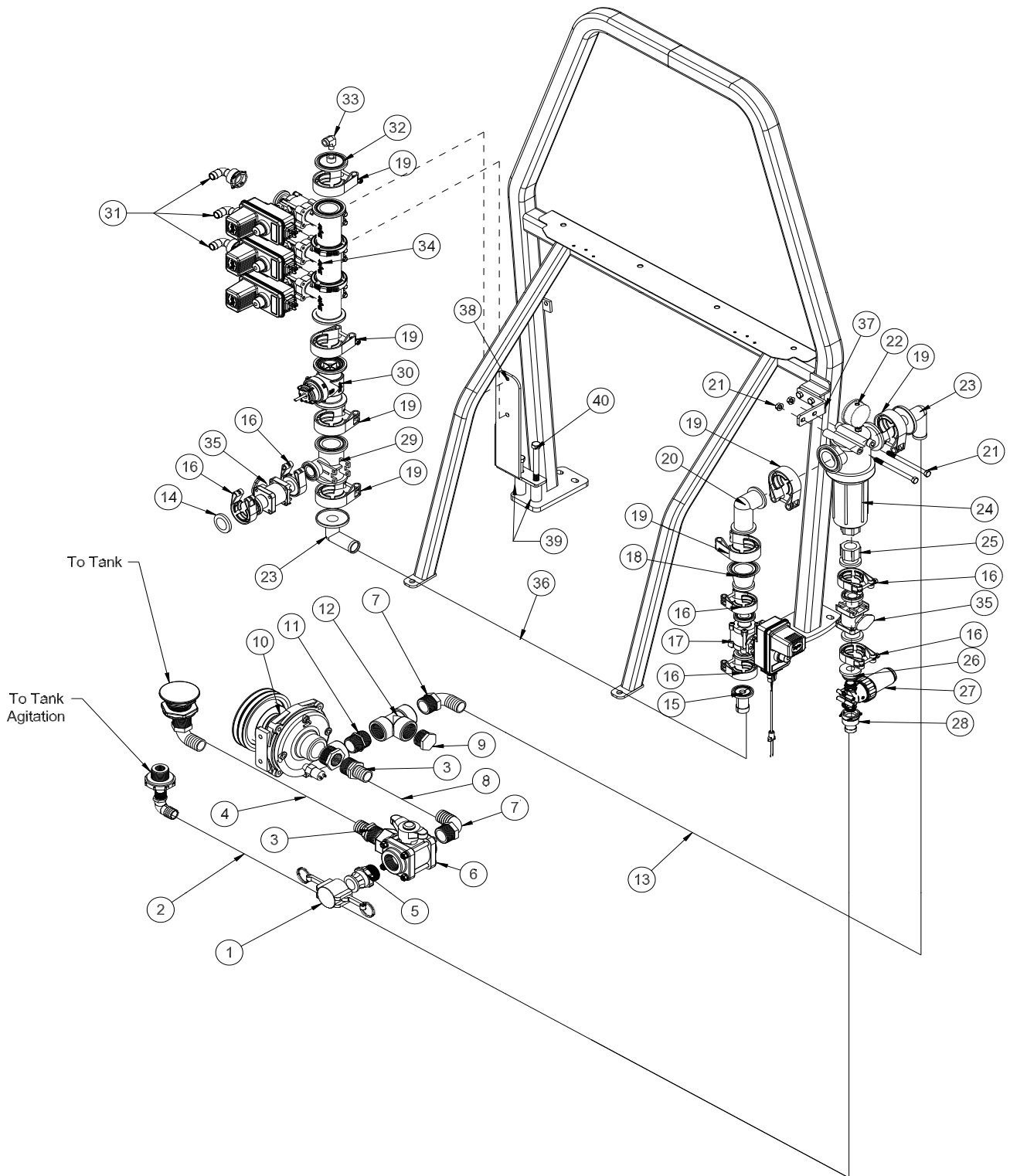

▲ IMPORTANT

If using Simulated Speed with a Radion 8140, one needs to change back to Ground Speed for proper rate control when spraying.

1202 PLUMBING PARTS LIST (RADION® 81401)

REF#	PART#	DESCRIPTION	QUANTITY
1	16-935	Quick Coupler Cap	1
2	8896-68	1" Suction Hose x 68"	1
	18-116	Hose Clamp	2
3	16-161	Fitting	2
4	8897-35	1 1/4" Discharge Hose x 35"	1
	18-222	Hose Clamp	2
5	16-180	Quick Coupler Male	1
6	18-372	3-Way Valve	1
	18-372-01	T-Handle	1
7	16-156	Elbow	2
8	8897-19	1 1/4" Discharge Hose x 19"	1
	18-222	Hose Clamp	2
9	10-389	Plug	1
10	15-970	Pump	1
11	16-880	Nipple	1
12	18-390	Tee	1
13	8897-60	1 1/4" Discharge Hose x 60"	1
	18-116	Hose Clamp	2
14	15-778	Blank Gauge Port Flange	1
15	15-870	#50 1 1/4" Hose Barb	1
16	15-740	#50 Series Clamp	6
17	20-785	Regulator Valve	1
18	15-748	Reducer Coupling (#75 to #50)	1
19	15-741	#75 Series Clamp	7
20	15-734	#75 Elbow Coupling	1
21	HB-38-16-500	Hex Bolt, 3/8 - 16 x 5	2
	HNFL-38-16	Flange Whiz-loc Nut, 3/8 - 16	2
22	16-281	Liquid Filled Gauge	1
23	15-739	#75 90° Hose Barb	2
24	15-737	Flanged Strainer	1
	16-968-03	Screen (50 mesh)	1
25	15-735	#50 x 1 FTP Fitting	1
26	15-825	#50 Male Quick Coupler	1
27	14-801	Agitator Line Strainer, 50 Mesh	1
	14-802	Replacement 50 Mesh Screen	
28	15-869	1" Hose Barb Outlet	1
	15-553-01	Clip	1
	15-553-02	O-ring	1
29	15-775	Reducer Tee	1
30	20-684	#802 Flow Meter	1

(Continued on next page)

1202 PLUMBING DRAWING (RADION® 8140)

15-818

#75 Fitting Oring

15-817

#50 Fitting Oring

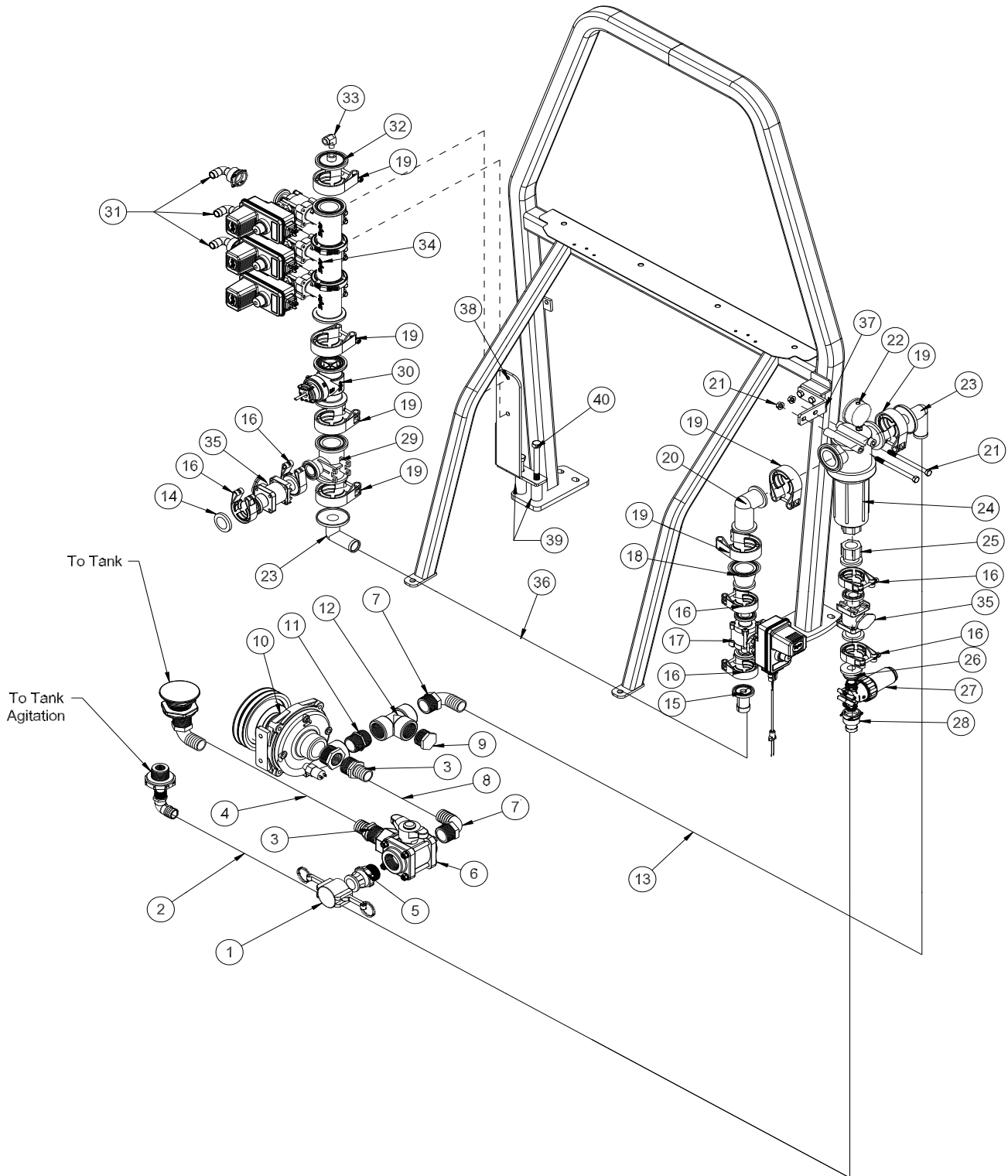

ACCESSORIES

1202 PLUMBING PARTS LIST (RADION® 8140)

REF#	PART#	DESCRIPTION	QUANTITY
31	15-553	3/4 - 90° Hose Barb	3
32	15-882	#75 Gauge Port	1
33	18-007	Street Elbow	1
34	15-743	Manifold Valve	1
35	15-738	Flanged Ball Valve	2
36	8897-66	1 1/4" Discharge Hose 66"	1
	18-116	Hose Clamp	2
37	15-904	Filter Bracket	1
	HB-38-16-100	Hex Bolt, 3/8 - 16 x 1	2
	HNFL-38-16	Flange Whiz-loc Nut, 3/8 - 16	2
38	15-708	Valve Mount	1
39	15-937	Valve Mount Spacer	2
40	HB-12-13-450	Hex Bolt, 1/2- 13 x 4 1/2	2
	HW-12	Washer, 1/2	2
	HNTL-12-13	Lock Nut, 1/2- 13	2

BOOM	LEFT HOSE	CENTER HOSE	RIGHT HOSE
15"	9032-125	9032-90	9032-136
18'	9032-125	9032-90	9032-136
20'	9032-135	9032-90	9032-146

▲ IMPORTANT

If using Simulated Speed with a Radion 8140, one needs to change back to Ground Speed for proper rate control when spraying.

1204 PLUMBING DRAWING (TEEJET® 744)

15-818
15-817

#75 Fitting Oring
#50 Fitting Oring

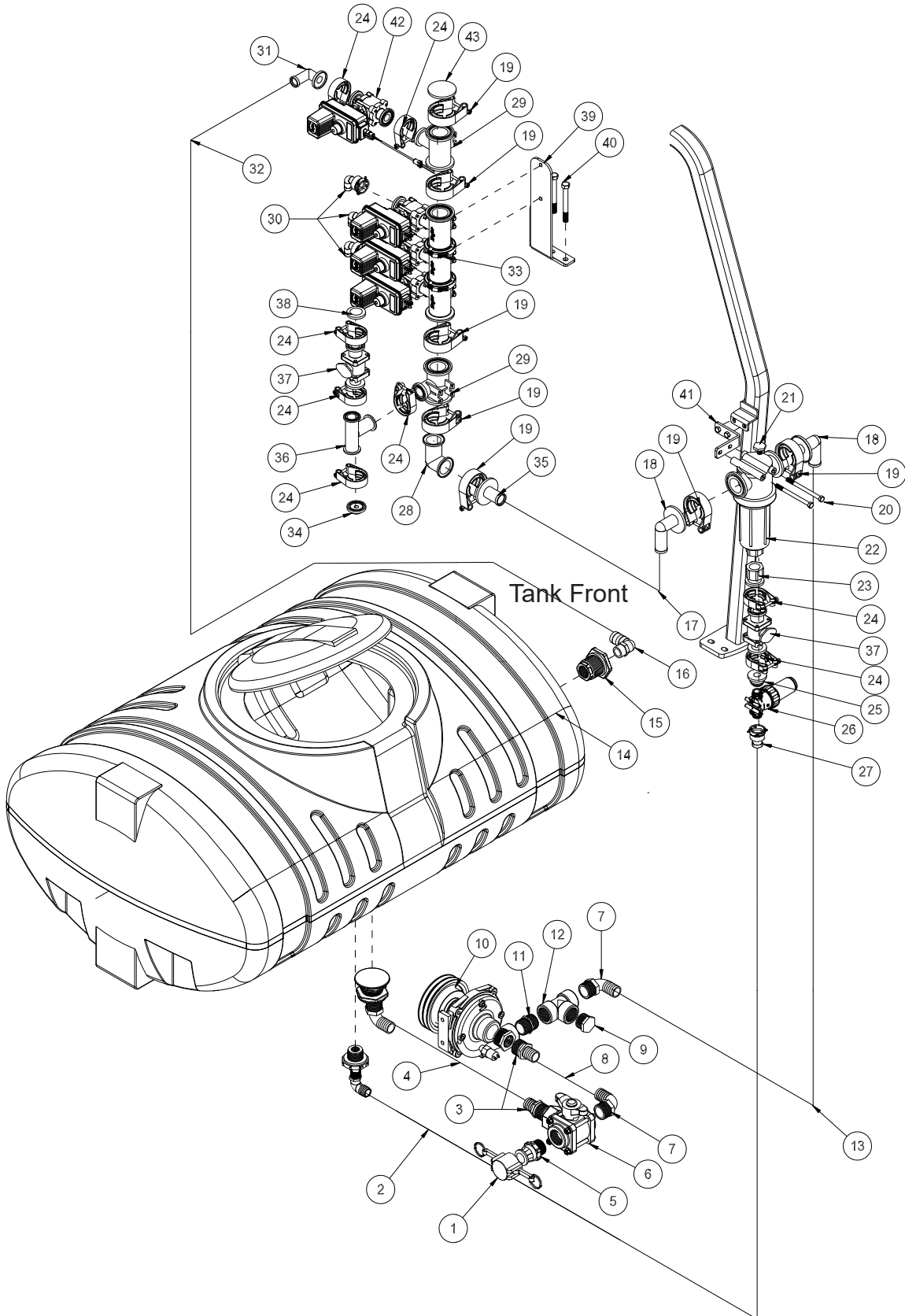

Accessories

1204 PLUMBING PARTS LIST (TEEJET® 744)

REF#	PART#	DESCRIPTION	QUANTITY
1	16-935	Quick Coupler Cap	1
2	8896-68	1" Suction Hose x 68"	1
	18-116	Hose Clamp	2
3	16-161	Fitting	2
	16-825	Hex Bushing	1
4	8897-35	1 1/4" Discharge Hose x 35"	1
	18-116	Hose Clamp	2
5	16-180	Quick Coupler Male	1
6	18-372	3-Way Valve	1
	18-372-01	T-Handle	1
7	16-156	Elbow	2
8	8897-19	1 1/4" Discharge Hose x 19"	1
	18-222	Hose Clamp	2
9	10-389	Plug	1
10	15-970	Pump	1
11	16-880	Nipple	1
12	18-390	Tee	1
13	8897-60	1 1/4" Discharge Hose x 60"	1
	18-116	Hose Clamp	2
14	20-802	200 Gallon Spray Tank	1
15	16-945	Double Thread Fitting(part of tank)	1
16	15-779	Hose Barb (remove plug)	1
17	8897-70	1 1/4" Discharge Hose x 70"	1
	18-116	Hose Clamp	2
18	15-739	#75 90° Hose Barb	2
19	15-741	#75 Series Clamp	7
20	HB-38-16-500	Hex Bolt, 3/8 - 16 x 5	2
	HNFL-38-16	Flange Whiz-loc Nut, 3/8 - 16	2
21	15-780	Poly Hex Plug	1
22	15-737	Flanged Strainer	1
	16-968-03	Screen (50 mesh)	1
23	15-735	#50 1" FTP Fitting	1
24	15-740	#50 Series Clamp	8
25	15-825	QC Flange Adapter	1
26	14-801	Agitator Line Strainer, 50 Mesh	1
	14-802	Replacement 50 Mesh Screen	
27	15-869	1" Hose Barb Outlet	1
	15-553-01	Clip	1
	15-553-02	O-ring	1
28	15-734	#75 Elbow Coupling	1
29	15-775	Reducer Tee	2

(Continued on next page)

1204 PLUMBING DRAWING (TEEJET® 744)

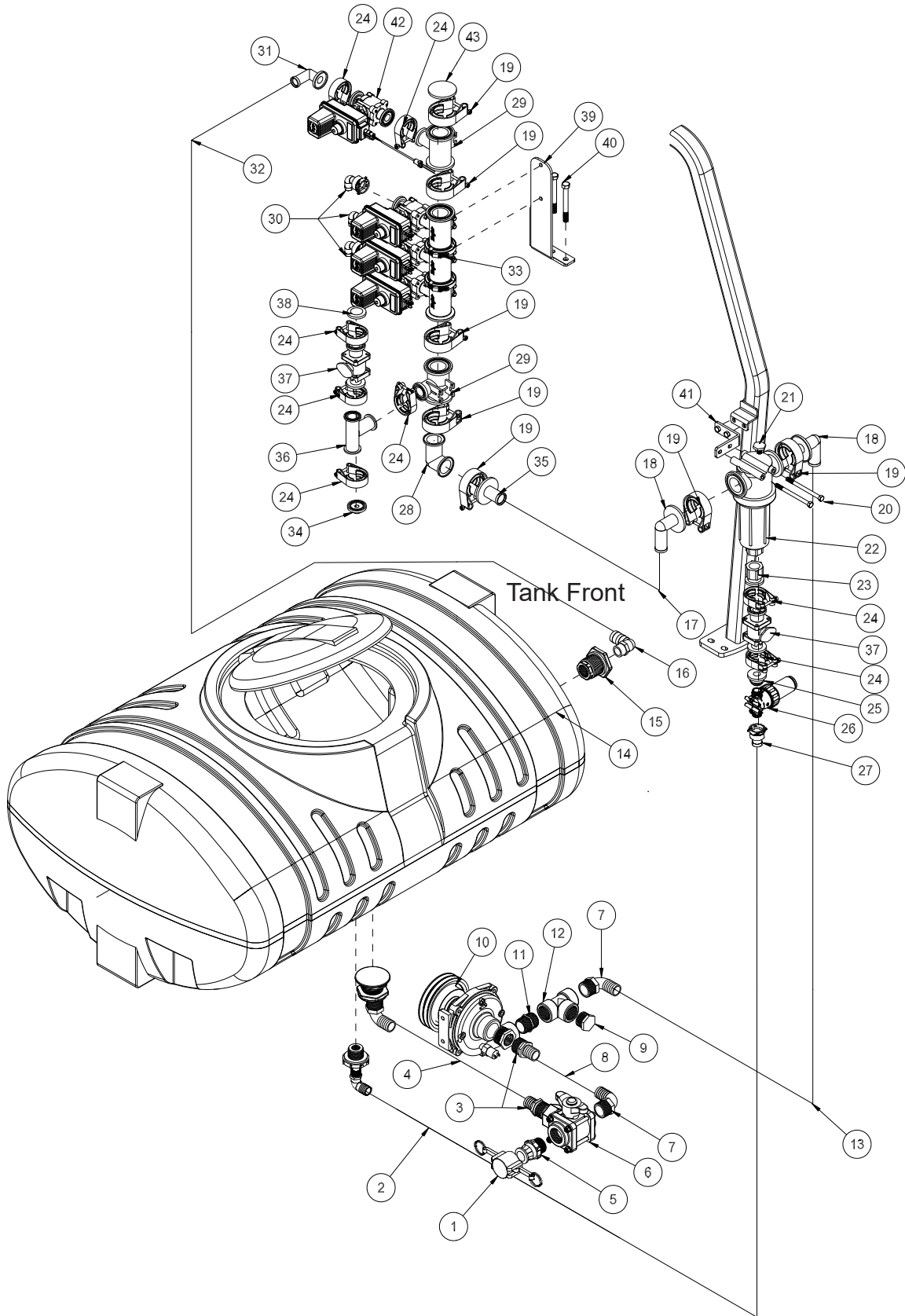

Accessories

1204 PLUMBING PARTS LIST (TEEJET® 744)

REF#	PART#	DESCRIPTION	QUANTITY
30	15-553	3/4- 90° Hose Barb	3
31	15-976	#50 -90° X 1-1/4 Hose Barb	1
32	8897-30	1 1/4" Discharge Hose x 30"	1
	18-116	Hose Clamp	2
33	15-743	Manifold Ball Valve	1
34	15-777	Gauge Port Flange	1
35	15-744	#75 Hose Barb	1
36	15-776	#50 Tee	1
37	15-738	Flanged Ball Valve	2
38	15-778	Blank Gauge Port Flange	1
39	15-708	Valve Mount	1
40	HB-12-13-250	Hex Bolt, 1/2- 13 x 2 1/2	2
	HW-12	Washer, 1/2- 13	2
	HNTL-12-13	Lock Nut, 1/2- 13	2
41	15-904	Filter Bracket	1
	HB-38-16-100	Hex Bolt, 3/8 - 16 x 1	2
	HNFL-38-16	Flange Whiz-loc Nut, 3/8 - 16	2
42	20-817	Regulating Valve	1
43	15-742	#75 Inlet Cover	1

<u>BOOM</u>	<u>LEFT HOSE</u>	<u>CENTER HOSE</u>	<u>RIGHT HOSE</u>
15"	9032-125	9032-90	9032-136
18'	9032-125	9032-90	9032-136
20'	9032-135	9032-90	9032-146

1202 SYSTEM WIRING (RADION® 8140)

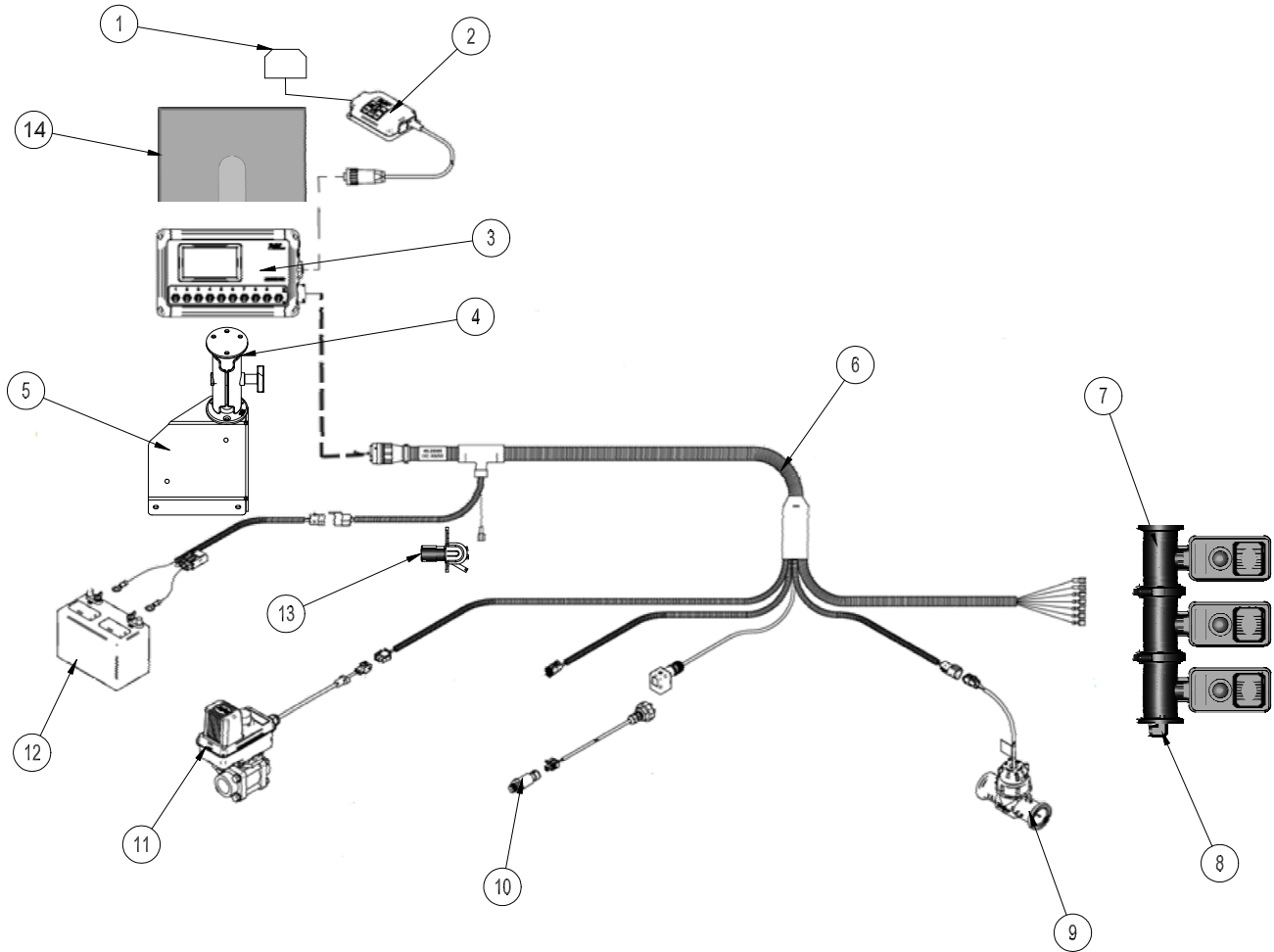

IMPORTANT

If using Simulated Speed with a Radion 8140, one needs to change back to Ground Speed for proper rate control when spraying.

REF#	PART#	DESCRIPTION	QUANTITY
1*		Antenna	1
2*	20-687-02	GPS Speed Sensor	1
3*	20-697-01	Radion 8140 Console	1
4	20-540	Ram Mount	1
5	10-643	Mount Bracket	1
6*		Wire Harness	1
7	15-743	Manifold Valve	1
8	18-007	Elbow	1
9	20-684	Flow Meter	1
10*	20-670-04	Pressure Sensor	1
11	20-785	Regulator Valve	1
12	33-509	Master Boom Control	1
13	33-216	Battery	1
14	20-781	Radion Console Cover	1
*	20-697	TeeJet® Radion Kit (includes * items)	1

Use Dielectric Grease On All Electrical Connections

1204 SYSTEM WIRING [TEEJET 744®]

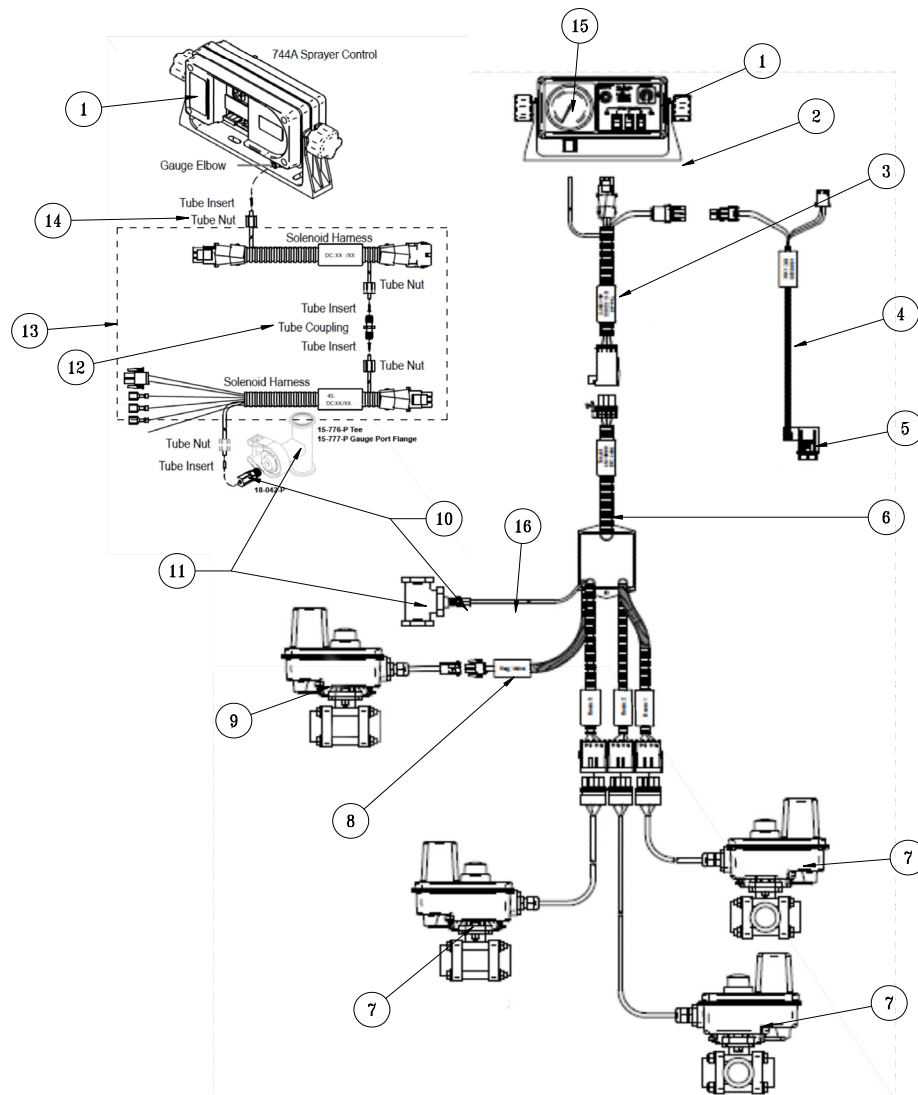

REF#	PART#	DESCRIPTION	QUANTITY
1*	20-688-02	744A Console	1
	20-688-01	200PSI Gauge	1
	20-688-08	Gauge Elbow	1
2	10-718	Mount Bracket	1
3*		Console harness	1
4*		Fused Power Cable	1
5	33-271	Fuse Block	1
6*		Ball Valve Wire Harness	1
7	15-743	Manifold Ball Valve	1
8*		Regulator Valve Adapter	1
9	20-817	Regulating Valve	1
10	18-042	Reducer Bushing	1
11	15-776	Tee, 50 Series	1
	15-777	Gauge Port Flange	1
12*	20-688-05	Tube Coupling	1
13*		Tube Nut Kit	1
14*	20-688-06	Tube Nut	1
15*	20-688-01	PSI Liquid Gauge	1
16*	20-688-04	Tubing	1

* 20-688 744A Kit Complete (includes * items)

CONTROL MOUNTS

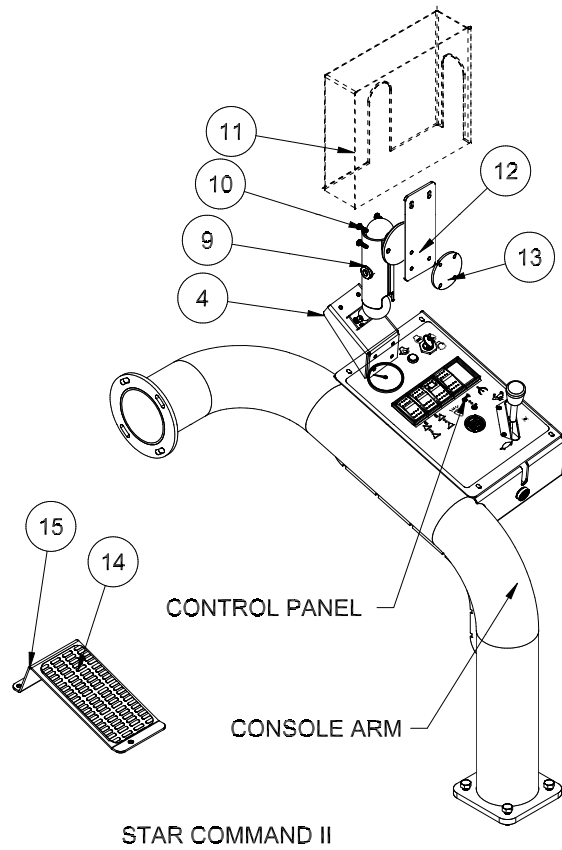
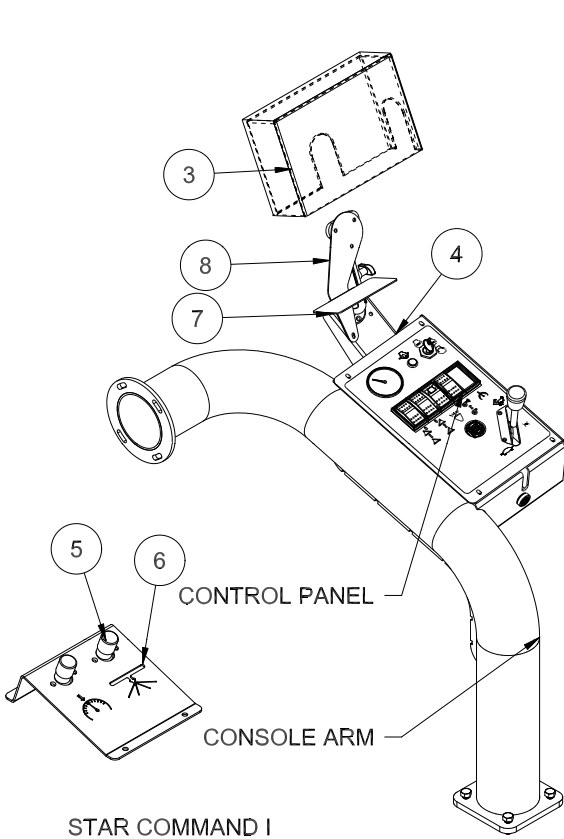
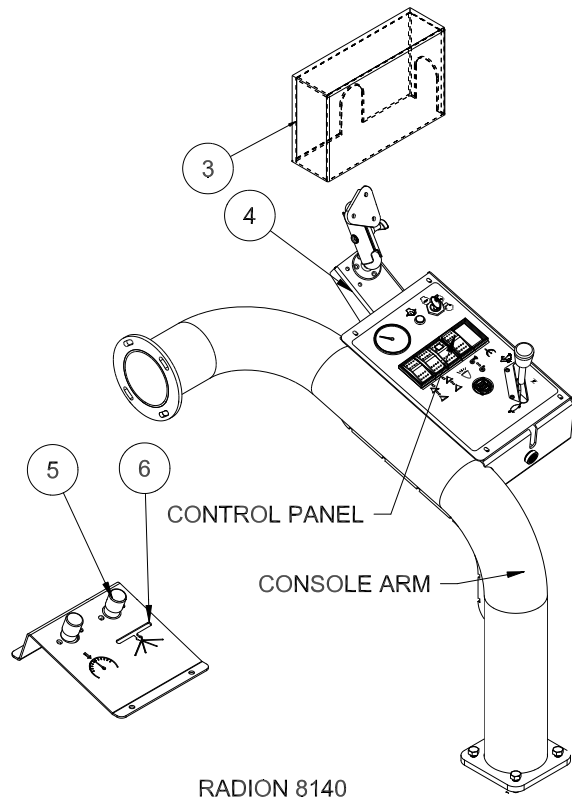
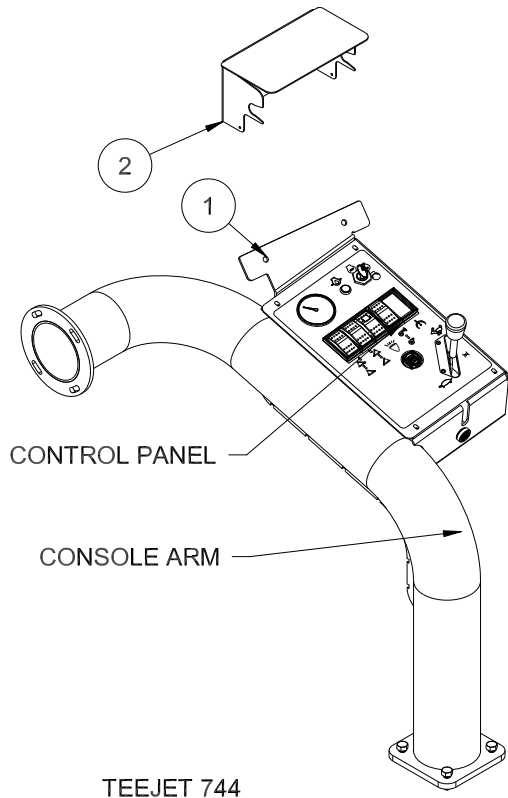

CONTROL MOUNTS

REF#	PART#	DESCRIPTION	QUANTITY
1	10-718	744 Control Mount	1
2	20-782	Rain Cover	1
3	20-781	Cover for Radion Control	1
4	10-721	Short Ram Mount	1
5	33-509	Master Boom Switch	1
6	10-705	Switch Foot Plate	1
7	10-716	DynaJet Control Cover	1
8	10-719	Radion/DynaJet Control Mount	1
9	HSM-10-32-075	Machine Screw, 10-32 x ³ / ₄	6
10		Star Command II RAM Mount	1
11	20-836	Star Command II Cover	1
12	32-690	Star Command II Control Mount	1
13	32-691	Control Mount Spacer	1

1207/1208/1215/1218/1220 PLUMBING DRAWING

BOOM	LEFT HOSE	CENTER HOSE	RIGHT HOSE
15"	9032-115	9032-90	9032-126
18'	9032-125	9032-90	9032-136
20'	9032-135	9032-90	9032-146

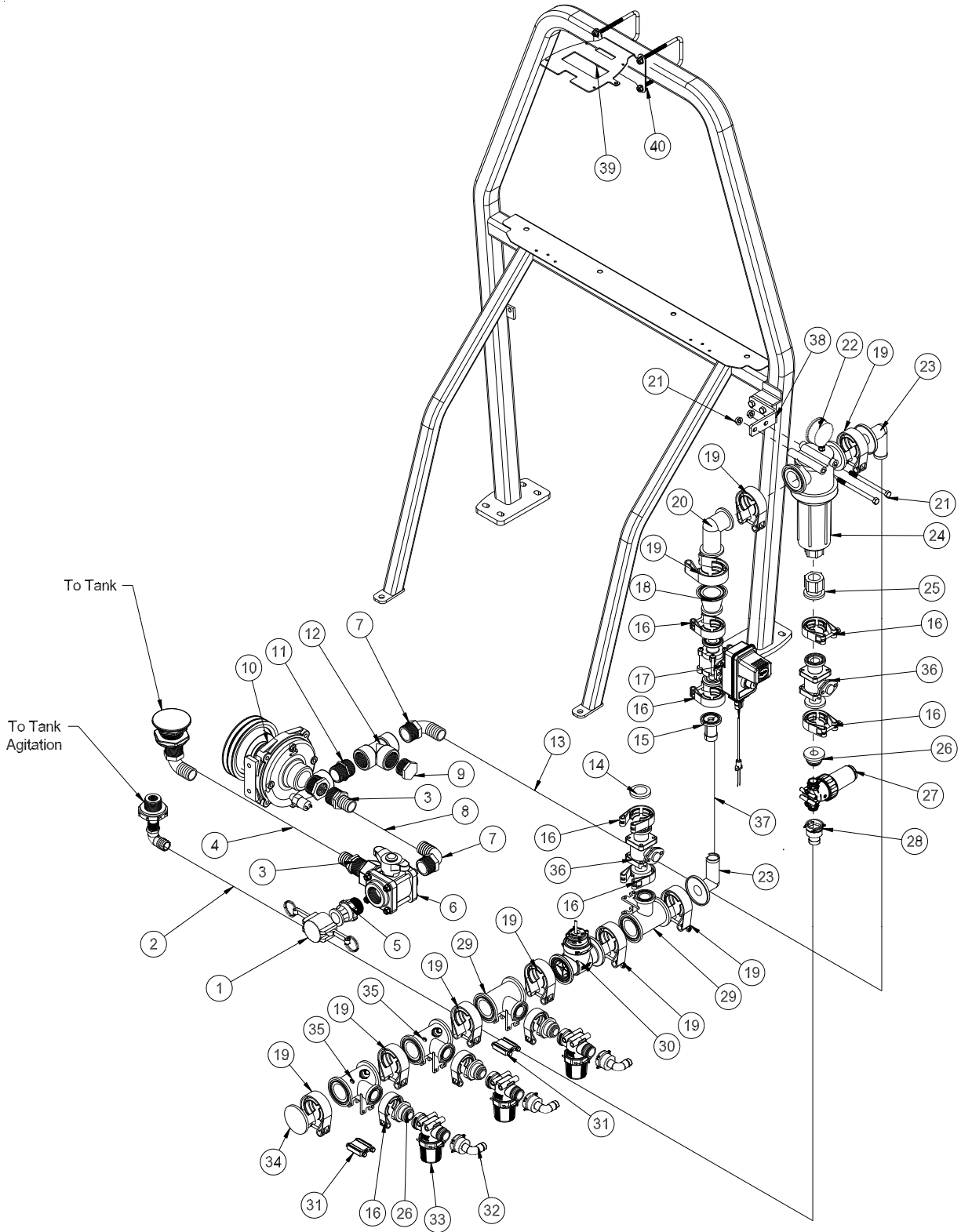

Accessories

1207/1208/1215/1218/1220 PLUMBING PARTS LIST

REF#	PART#	DESCRIPTION	QUANTITY
1	16-935	Quick Coupler Cap	1
2	8896-68	1" Suction Hose x 68"	1
	18-116	Hose Clamp	2
3	16-161	Fitting	2
4	8897-32	1 1/4" Discharge Hose x 32"	1
	18-222	Hose Clamp	2
5	16-180	Quick Coupler Male	1
6	18-372	3-Way Valve	1
	18-372-01	T-Handle	1
7	16-156	Elbow	2
8	8897-19	1 1/4" Discharge Hose x19"	1
	18-222	Hose Clamp	2
9	10-389	Plug	1
10	16-998	Pump	1
11	16-880	Nipple	1
12	18-390	Tee	1
13	8897-60	1 1/4" Discharge Hose x 60"	1
	18-116	Hose Clamp	2
14	15-778	Blank Gauge Port Flange	1
15	15-870	#50 1 1/4" Hose Barb	1
16	15-740	#50 Series Clamp	9
17	20-785	Regulator Valve	1
18	15-748	Reducer Coupling (#75 to #50)	1
19	15-741	#75 Series Clamp	9
20	15-734	#75 Elbow Coupling	1
21	HB-38-16-500	Hex Bolt, 3/8 - 16 x 5	2
	HNFL-38-16	Flange Whiz-loc Nut, 3/8 - 16	2
22	16-281	Liquid Filled Gauge	1
23	15-739	#75 90° Hose Barb	2
24	14-628	Flanged Strainer with 80 Mesh screen	1
25	15-735	#50 x 1 FTP Fitting	1
26	15-825	#50 Male Quick Coupler	4
27	14-801	Agitator Line Strainer, 50 Mesh	1
	14-802	Replacement 50 Mesh Screen	
28	15-869	1" Hose Barb Outlet	1
	15-553-01	Clip	1
	15-553-02	O-ring	1
29	15-775	Reducer Tee	2
30	20-684	#802 Flow Meter	1
31	15-743-03	Mounting Rail	2
	15-743-06	SS Screw	8
32	15-553	3/4 - 90° Hose Barb	3
33	14-607	QC Strainer 100 Mesh	3
	14-609	Replacement 100 Mesh Screen	
34	15-742	#75 Inlet Cover	1
35	30-164	Tapped Reducer Tee	2
36	15-738	Flanged Ball Valve	2
37	8897-66	1 1/4" Discharge Hose x 66"	1
	18-116	Hose Clamp	2
38	15-904	Filter Bracket	1
	HB-38-16-100	Hex Bolt, 3/8 - 16 x 1	2
	HNFL-38-16	Flange Whiz-loc Nut, 3/8 - 16	2
39	20-770	Receiver Mount(Star Command II Only)	1
40	17-537	U-bolt (Star Command II Only)	2

1207/1208 DYNAJET WIRING

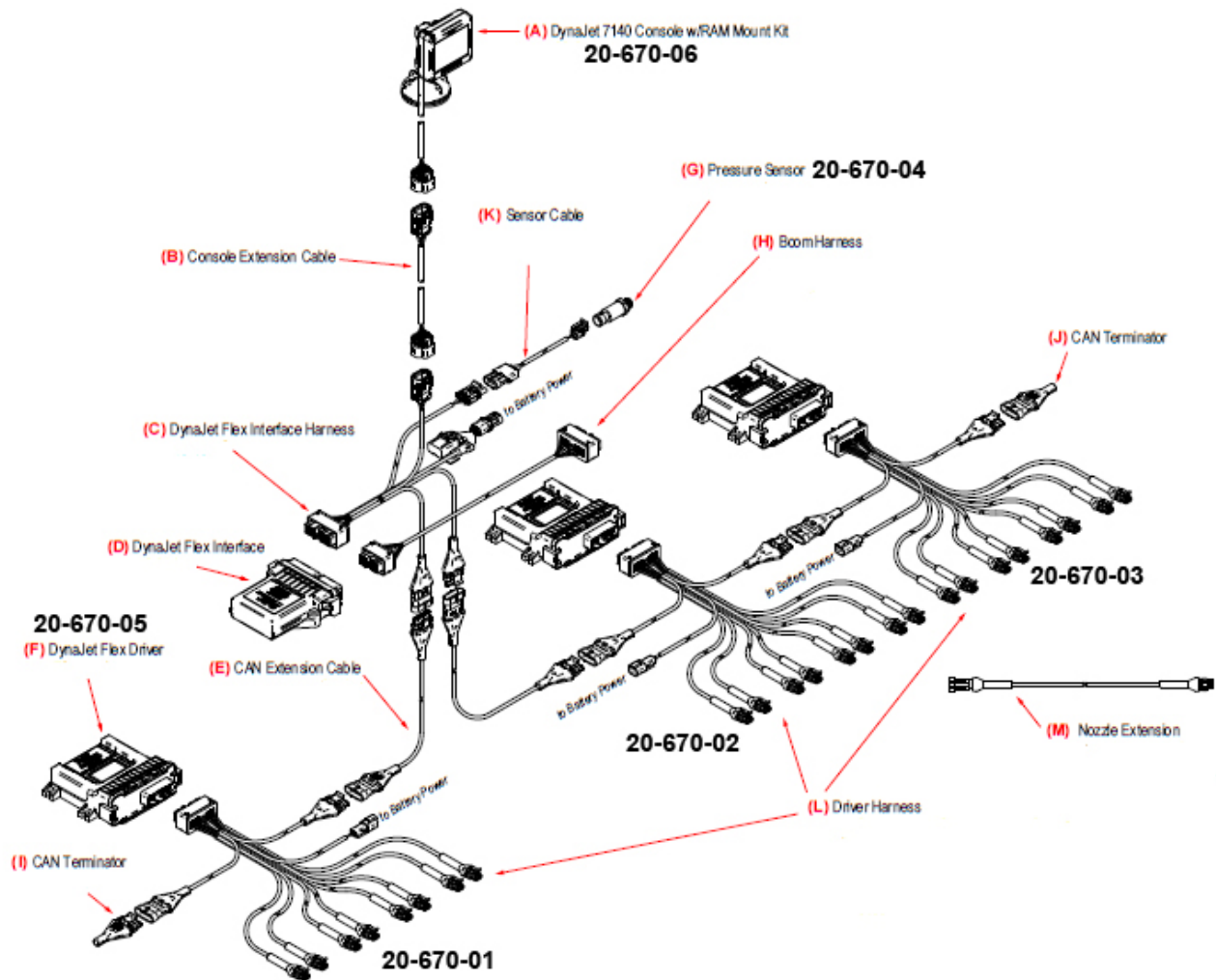

ACCESSORIES

1207/1208 MODULE MOUNTS

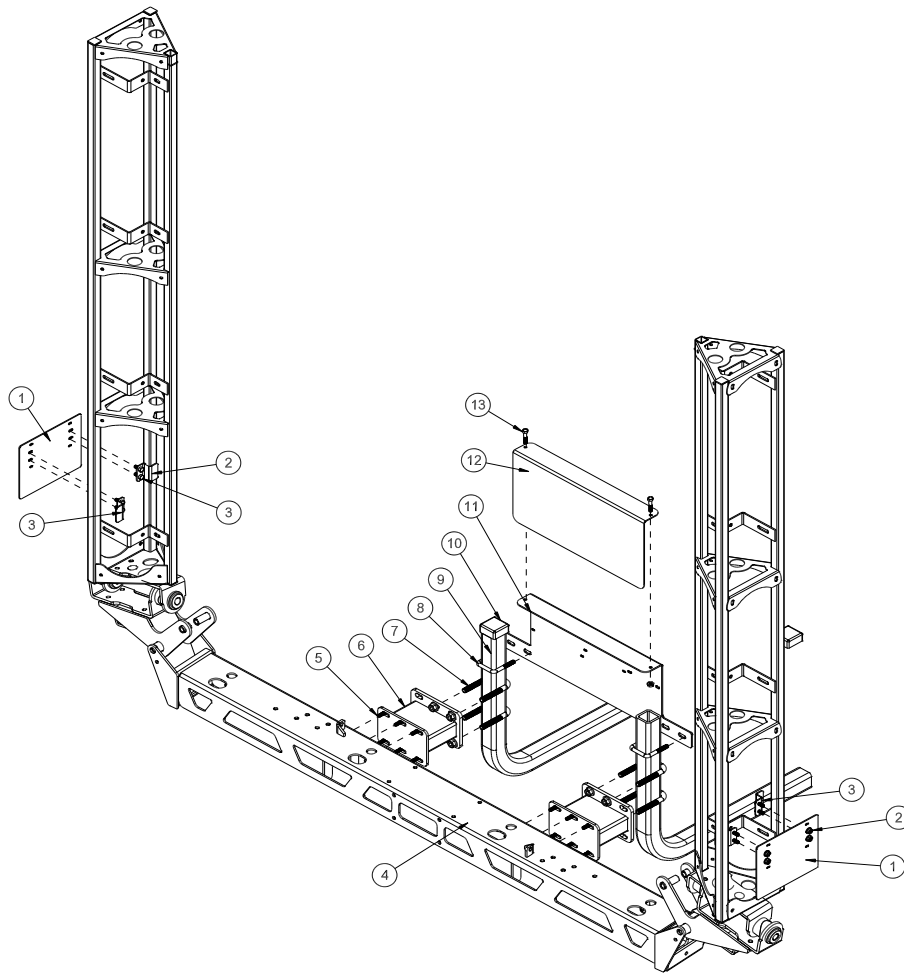

REF#	PART#	DESCRIPTION	QUANTITY
1	20-665	Drive Module Bracket	2
2	20-664	Z Bracket	4
3	HSTP-14-20-075	Machine Screw, $\frac{1}{4}$ - 20 x $\frac{3}{4}$	10
	HNFL-14-20	Flange Whiz Lock Nut, $\frac{1}{4}$ - 2	10
4		Center Boom Mount	1
5	HB-516-18-100	Bolt, $\frac{5}{16}$ - 18 x 1	12
	HNTL-516-18	Lock Nut, $\frac{5}{16}$ - 18	12
6	17-614	Boom Spacer	2
7	20-555	U-Bolt	4
	HNFL-12-13	Flange Whiz-loc Nut, $\frac{1}{2}$ - 13	8
8	17-537	Square U-bolt	2
9	17-615	Boom Carrier	2
10	16-557	Square Cap	2
11	20-667	Module Mount Bracket	1
12	20-666	Module Cover Bracket	1
13	HB-516-18-150	Hex Bolt, $\frac{5}{16}$ - 18 x $1\frac{1}{2}$	2
	HNFL-516-18	Flange Whiz-loc Nut, $\frac{5}{16}$ - 18	2

AEROS WIRING FOR 1215/1218/1220

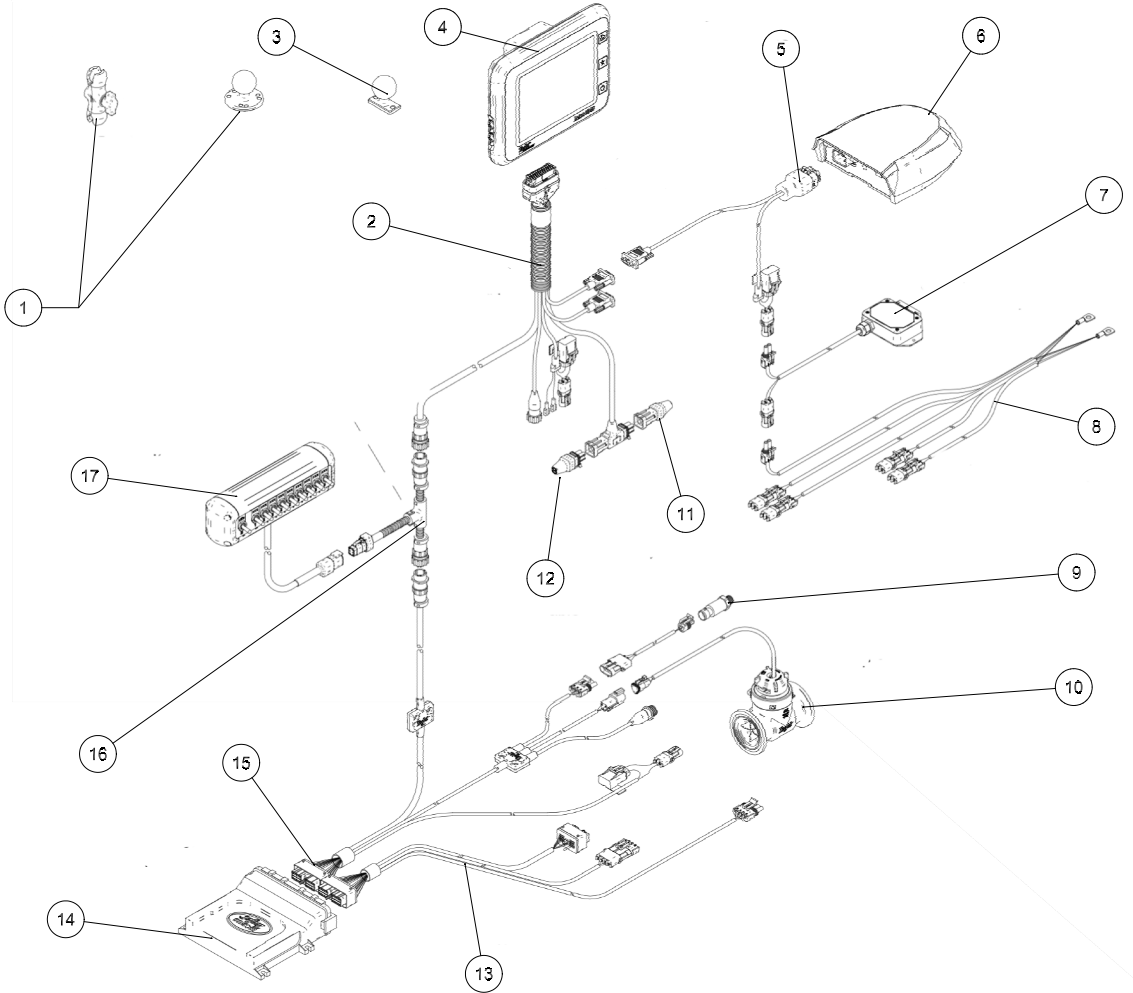

REF#	PART#	DESCRIPTION	QUANTITY
1		RAM Mount	1
2		Aeros Harness w/ ISO CAN	1
3	32-709	RAM Base	1
4	20-868-03	Aeros Console	1
5	20-736-01	Antenna Cable	1
6	20-767	RX720 Receiver	1
7	20-686-02	Switch Box	1
8		Power Cable	1
9	20-670-04	Pressure Sensor	1
10	20-684	Flow Meter	1
11		Terminator, Male	1
12		Terminator, Female	1
13		DynaJet Interface Boom Harness	1
14	20-806	IC18 Sprayer Module	1
15		IC18 Harness	1
16		TeeJet In-Cab Cable	1
17	20-686-01	Switch Box	1
NS	17-647	E-chemsaver Extensin Cable for 15' Boom	

DYNAJET WIRING FOR 1215/1218/1220

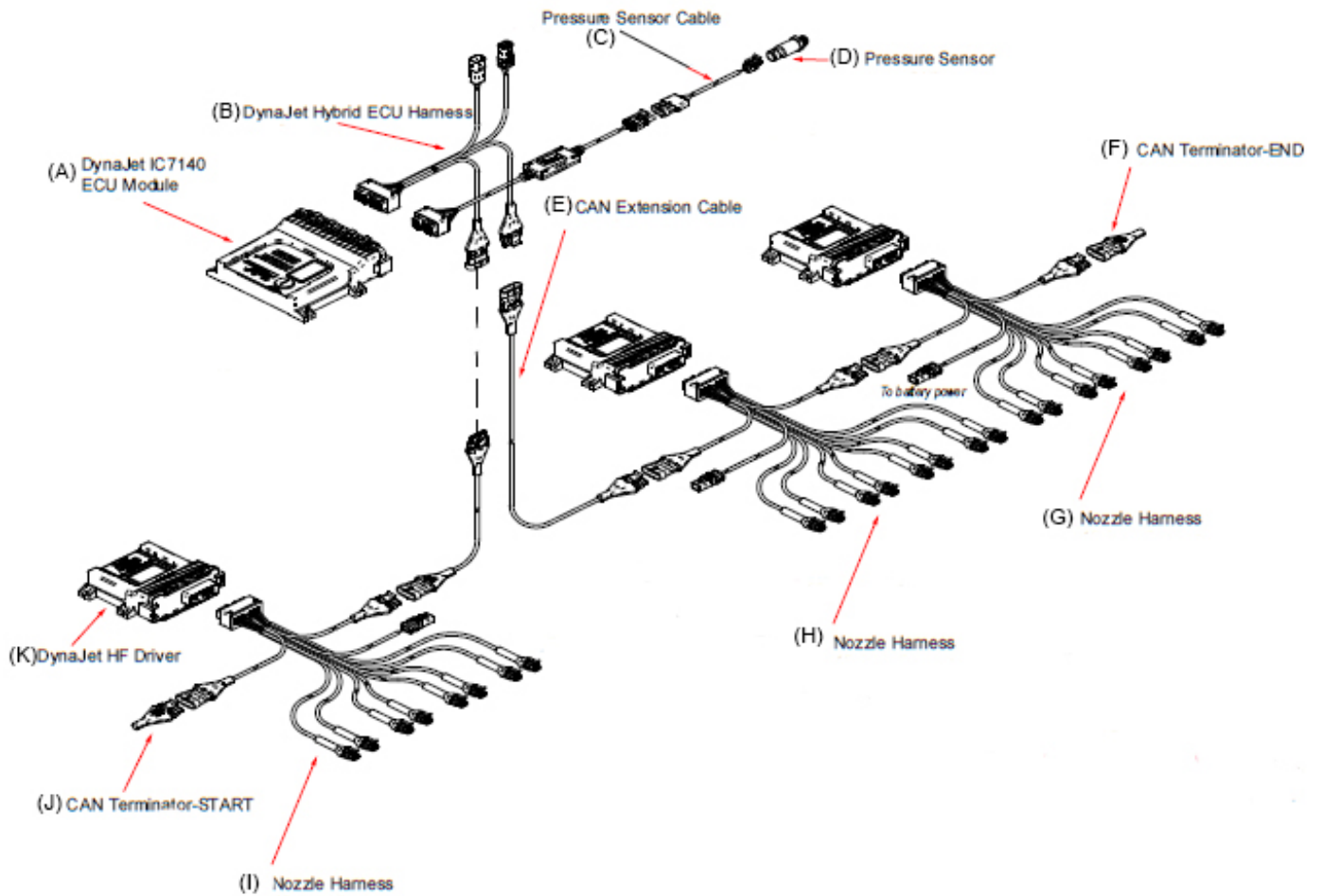

REF#	PART#	DESCRIPTION	QUANTITY
A		DynaJet IUC7140 Module	1
B		Harness, IC7140 to IC35	1
C		Cable, Pressure Sensor	1
D	20-670-04	Pressure Sensor	1
E		CAN Extension Cable	1
F	20-670-08	CAN Terminator End	1
G		Right Harness, DJ Driver	1
H		Center Harness, DJ Driver	1
I		Left Harness, DJ Driver	1
J		CAN Terminator Start	1
K	20-670-05	DynaJet Driver	3

Accessories

1215/1218/1220 MODULE MOUNTS

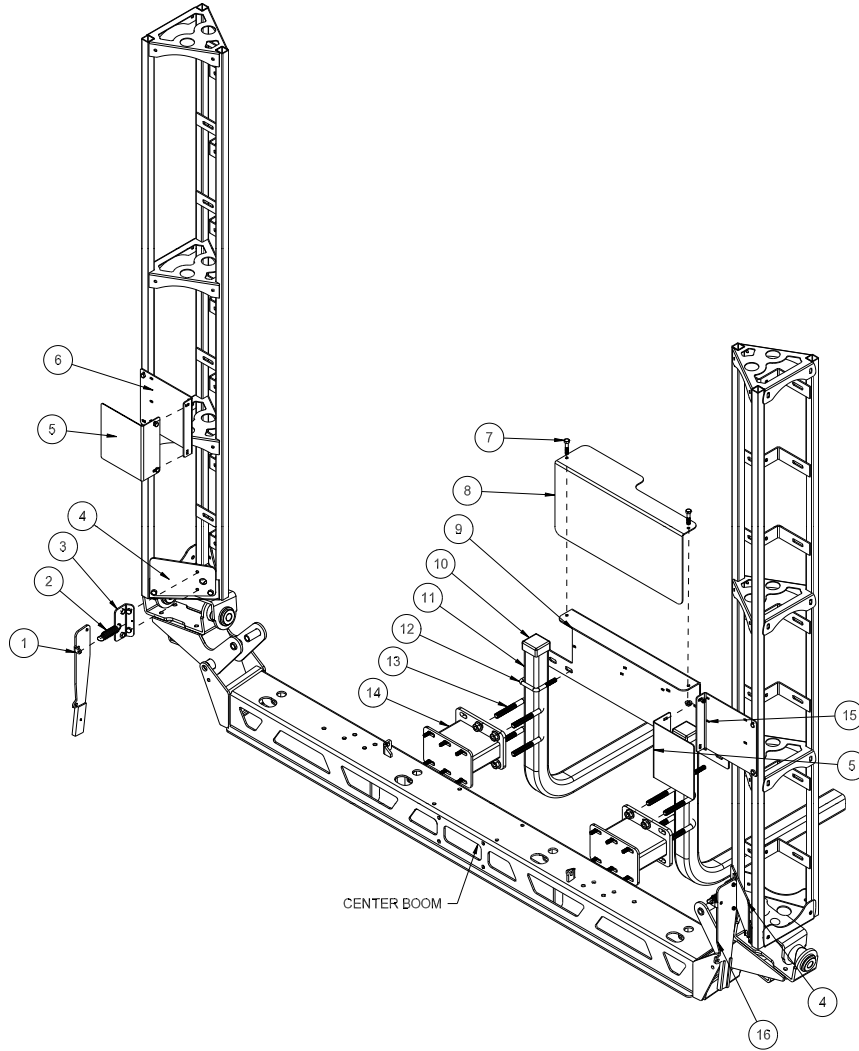

REF#	PART#	DESCRIPTION	QUANTITY
1	17-562	LH Break-Away Arm	1
2	11-050	Spring	2
3	17-560	Hinge Mount	2
4	17-559	Break-Away Mount	2
5	20-796	Bracket Cover	2
6	20-795	LH Driver Module Bracket	1
7	HB-516-18-150	Hex Bolt, $\frac{5}{16}$ -18 x $1\frac{1}{2}$	2
	HNFL-516-18	Flange Whiz-loc Nut, $\frac{5}{16}$ -18	2
8	20-794	Module Cover Bracket	1
9	10-625	Module Mount Bracket	1
10	16-557	Square Cap	2
11	17-615	Boom Carrier	2
12	17-537	Square U-bolt	1
13	20-555	U-Bolt	4
	HNFL-12-13	Flange Whiz-loc Nut, $\frac{1}{2}$ - 13	8
14	17-614	Boom Spacer	2
15	20-793	RH Driver Module Bracket	1
16	17-561	RH Break-Away Arm	1

14-801/14-607 STRAINER

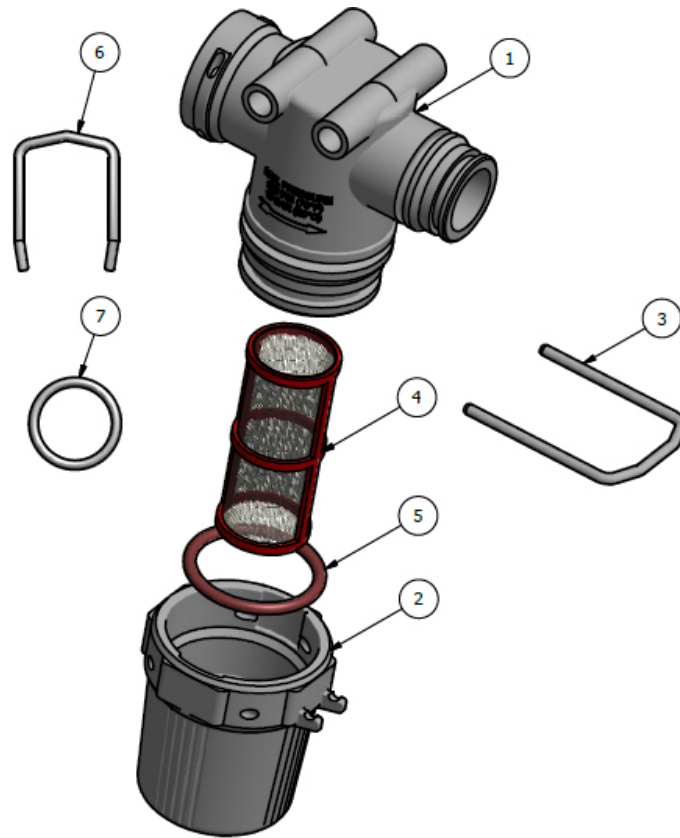

REF#	PART#	DESCRIPTION	QUANTITY
1		QC Strainer Head	1
2	14-801-01	Bowl	1
3		Strainer QC Retaining Clip	1
4*	14-802	50 Mesh Screen	1
**	14-609	100 Mwsh Screen	1
5	14-801-02	Viton O-ring	1
6	15-553-01	Retaining Clip	1
7	15-553-02	Viton O-ring	1
*	14-801	Agitation Strainer Assembly with 50 Mesh Screen	
**	14-607	QC Strainer Assembly with 100 Mesh Screen	

15-737/ 14-628 FLANGED STRAINER DRAWING

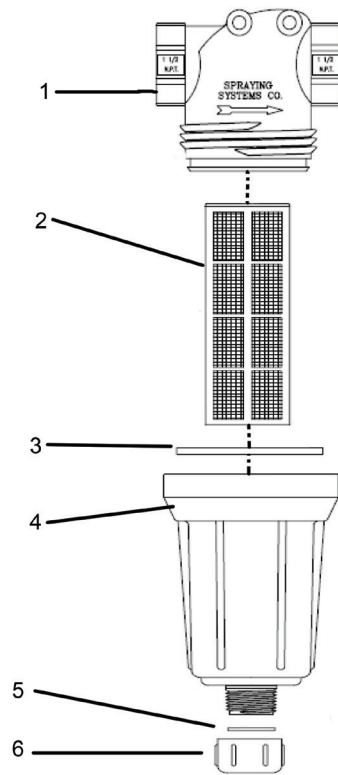

REF#	PART#	DESCRIPTION	QUANTITY
1	15-737-01	Strainer Head 75 Series	1
2*	16-968-03	50 Mesh Screen	1
**	16-968-05	80 Mesh Screen	1
3	14-521-02	EPDM Gasket	1
4	14-521-03	Bowl 1" NPT	1
5	14-521-04	EPDM Rubber gasket	1
6	14-521-05	Cap	1
*	15-737	Flanged Strainer Assembly with 50 Mesh Screen	
**	14-628	Flanged Strainer Assembly with 80 Mesh Screen	

15-743 MANIFOLD VALVE DRAWING

15-818
15-817

#75 Fitting Oring
#50 Fitting Oring

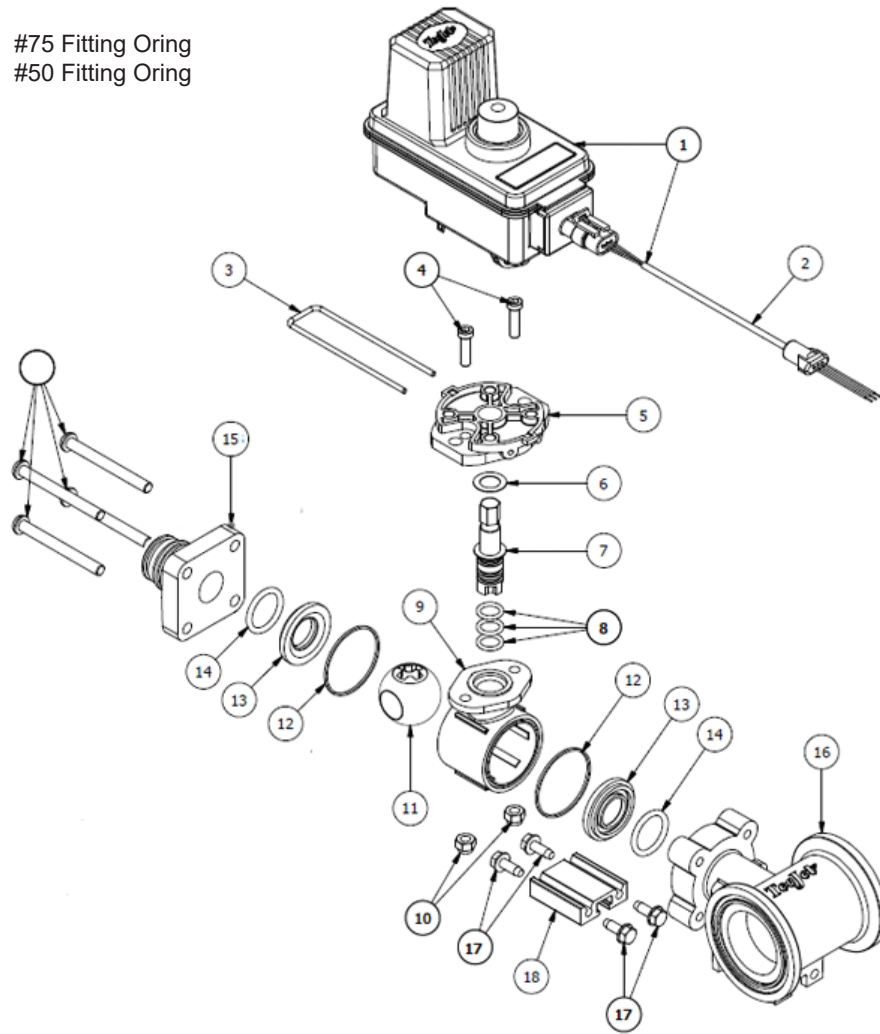

REF#	PART#	DESCRIPTION	QUANTITY
1	15-552-23	Motor	
2	15-878	Metri-Pack Cable (comes with motor)	1
3	15-552-24	Retaining Clip	1
4	15-552-25	Socket Head Cap Screw, Stainless Steel	2
5	15-552-26	Motor Adapter, Polypropylene	1
6*	15-517-11	Thrust Washer, Teflon	1
7	15-552-27	Stem, Stainless Steel	1
8	15-552-05	O-ring, Viton	3
9	15-517-16	Body, Nylon	1
10		Lock Nut, Stainless Steel	2
11	15-743-04	Ball, Polypropylene	1
12*	15-552-13	Gasket, Viton	2
13*	15-517-19	Seal, Teflon	2
14*	15-517-20	O-ring, Viton	2
15	15-743-01	End Cap	1
16	15-743-02	#75 Tee Body	1
17	15-743-06	Screw, SS	4
18	15-743-03	Mounting Rail Aluminum	1

* 15-552-10 Spare Parts Kit (includes all * items)
15-743-05 Single Valve (shown)

20-817 REGULATOR VALVE

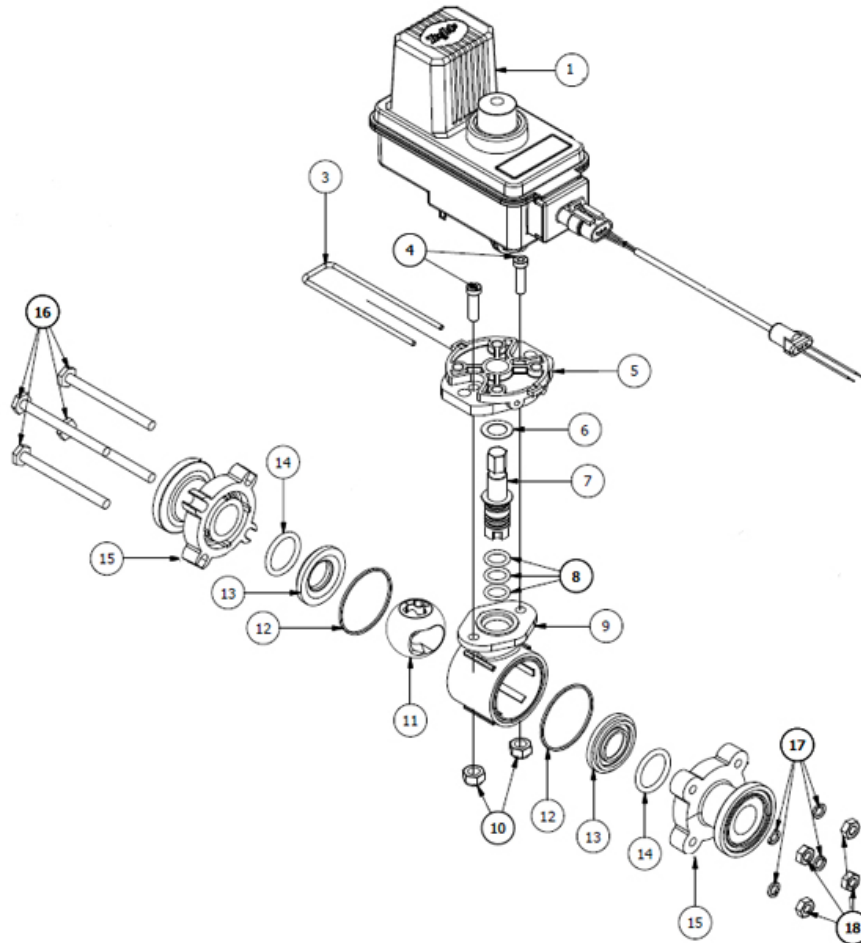

REF#	PART#	DESCRIPTION	QUANTITY
1		Motor,	1
3	15-552-24	Retaining Clip	1
4		Socket Head Cap Screw, Stainless Steel	2
5	15-552-26	Motor Adapter, Polypropylene	1
6*	15-517-11	Thrust Washer, Teflon	1
7	15-552-27	Stem, Stainless Steel	1
8	15-552-05	O-ring, Viton	3
9	15-517-16	Body, Nylon	1
10		Nylon Lock Nut, Stainless Steel	2
11		Ball, Polypropylene	1
12*	15-552-13	Gasket, Viton	2
13*	15-517-19	Seal, Teflon	2
14*	15-517-20	O-ring, Viton	2
15	15-743-01	End Cap	1
16		SS Hex Bolt, 1/4 - 20 x 3	4
17		SS Lock Washer, 1/4	4
18	15-517-23	SS Nut, 1/4 - 20	4
*	15-552-10	Spare Parts Kit	
	20-817	Complete Regulator Valve	

20-785 REGULATOR VALVE

15-818 #75 Fitting Oring
 15-817 #50 Fitting Oring

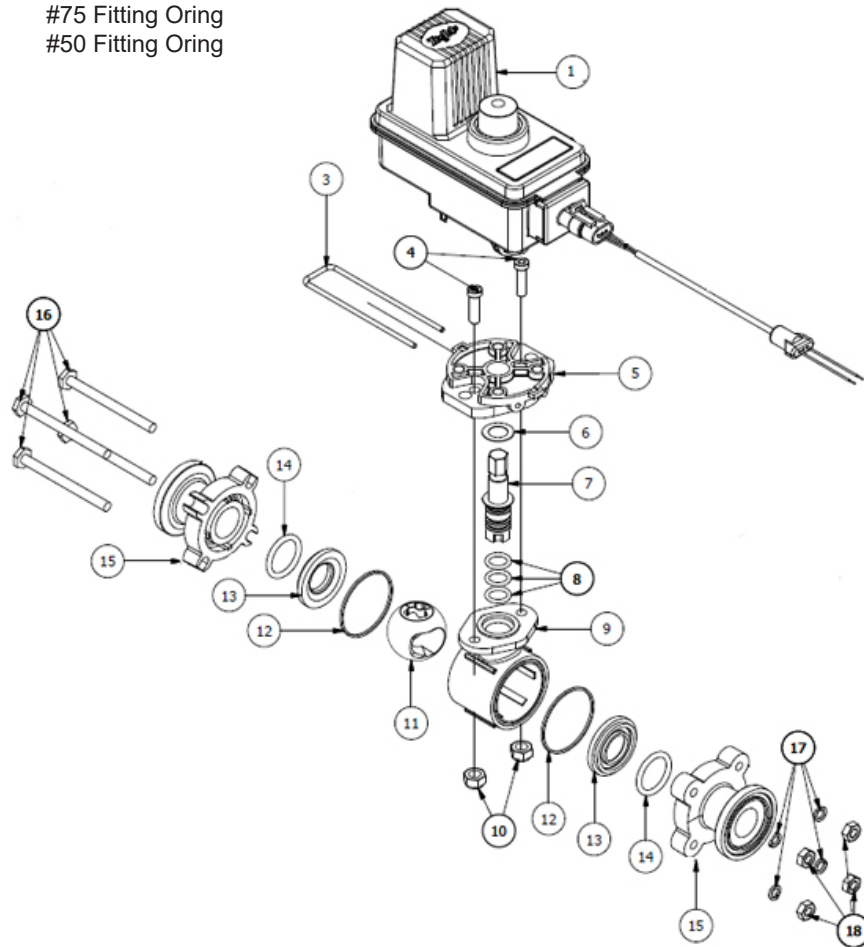

REF#	PART#	DESCRIPTION	QUANTITY
1	20-785-01	Motor, 6RPM	
3	15-552-24	Retaining Clip	1
4		Socket Head Cap Screw, Stainless Steel	2
5	15-552-26	Motor Adapter, Polypropylene	1
6*	15-517-11	Thrust Washer, Teflon	1
7	15-552-27	Stem, Stainless Steel	1
8	15-552-05	O-ring, Viton	3
9	15-517-16	Body, Nylon	1
10		Nylon Lock Nut, Stainless Steel	2
11		Ball, Polypropylene	1
12*	15-552-13	Gasket, Viton	2
13*	15-517-19	Seal, Teflon	2
14*	15-517-20	O-ring, Viton	2
15	15-743-01	End Cap	1
16		SS Hex Bolt, 1/4 - 20 x 3	4
17		SS Lock Washer, 1/4	4
18	15-517-23	SS Nut, 1/4 - 20	4
*	15-552-10	Spare Parts Kit	
	20-785	Complete Regulator Valve	

17-580 20' HEAVY BOOM

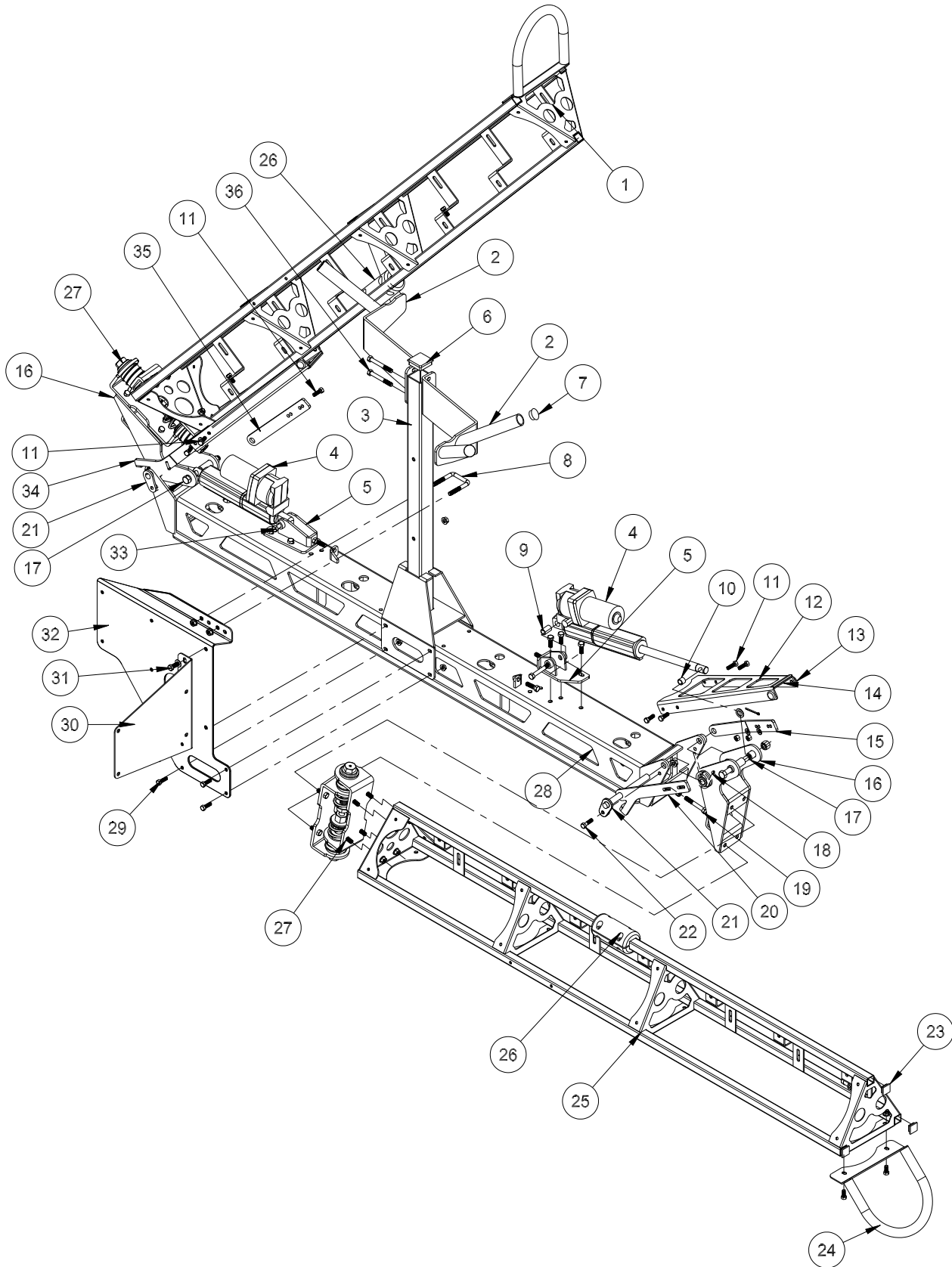

Accessories

17-580 20' HEAVY BOOM

REF#	PART#	DESCRIPTION	QUANTITY
1	17-652	Left Boom Arm	1
2	17-631	V-Boom Nest	2
3	17-578	Boom Nest Post	1
4	30-214	10" Electric Hydraulic Actuator	2
5	30-184	Actuator Mount	2
	HN-38-16	Hex Nut, $\frac{3}{8}$ - 16 (adjustment Hex Bolt)	4
	HB-38-16-100	Hex Bolt, $\frac{3}{8}$ - 16 x 1	6
	HW-38	Flat Washer, $\frac{3}{8}$	6
	HNFL-38-16	Flange Whiz-loc Nut, $\frac{3}{8}$ -16	6
6	18-297	Cap Plug	1
7	17-619	Push in Plug	4
8	17-537	Square U-Hex Bolt	1
9	18-036	1" Bushing (part of 30-214)	2
10	18-234	$\frac{1}{2}$ " Bushing (part of 30-214)	2
11	HB-516-18-100	Hex Bolt, $\frac{5}{16}$ -16 x 1	8
	HW-516	Flat Washer, $\frac{5}{16}$	4
	HNTL-516-18	Nylon Lock Nut, $\frac{5}{16}$ - 18	8
12	17-587	Boom Lock	2
13	8803-2.75	Trim Lace, $2\frac{3}{4}$	2
14	42-116	Rubber Insert	4
15	17-588	Lock Hinge, RH	1
16	30-185	Arm Pivot Hinge	2
	HG-14-28-180	Grease Fitting, $\frac{1}{4}$ - 28 x 180°	2
	76-128	Bushing	4
17	HB-12-13-500	Hex Bolt, $\frac{1}{2}$ - 13 x 5	2
	HNTL-12-13	Nylon Lock Nut, $\frac{1}{2}$ - 13	2
18	17-597	Torsion Spring, RH	1
19	HB-38-16-175	Hex Bolt, $\frac{3}{8}$ - 16 x $1\frac{3}{4}$	2
	HNFL-38-16	Flange Whiz-loc Nut, $\frac{3}{8}$ -16	4
20	17-589	Limit Hinge, RH	1
21	17-596	Hinge Pin w/Spacer	2
	HP-18-100	Cotter Pin, $\frac{1}{8}$ x 1	2
22	HB-516-18-100	Hex Bolt, $\frac{5}{16}$ -16 x 1	2
	HNFL-516-18	Flange Whiz-loc Nut, $\frac{5}{16}$ - 18	2
23	30-258	1" 10-14ga Ribbed Plug	10
24	17-541	Boom End Guard	2
	HBFL-516-18-075	Flange Whiz-loc Bolt, $\frac{5}{16}$ - 18 x $\frac{3}{4}$	4
	HNFL-516-18	Flange Whiz-loc Nut, $\frac{5}{16}$ - 18	4
25	17-653	Right Boom Arm	1
26	17-573	Guide Block Set	2
	HB-14-20-125	Hex Bolt, $\frac{1}{4}$ -20 x $1\frac{1}{4}$	8
	HNTL-14-20	Nylon Lock Nut, $\frac{1}{4}$ - 20	8
27	17-632	Boom Hinge Complete	2
	HB-38-16-100	Hex Bolt, $\frac{3}{8}$ - 16 x 1	16
	HNFL-38-16	Flange Whiz-loc Nut, $\frac{3}{8}$ - 16	16
28	17-651	Boom Center	1
29	HB-516-18-075	Hex Bolt, $\frac{5}{16}$ - 18 x $\frac{3}{4}$	8
	HW-516	Flat Washer, $\frac{5}{16}$	8
	HNFL-516-18	Flange Whiz-loc Nut, $\frac{5}{16}$ - 18	8

(Continue on next page)

17-580 20' BOOM DRAWING

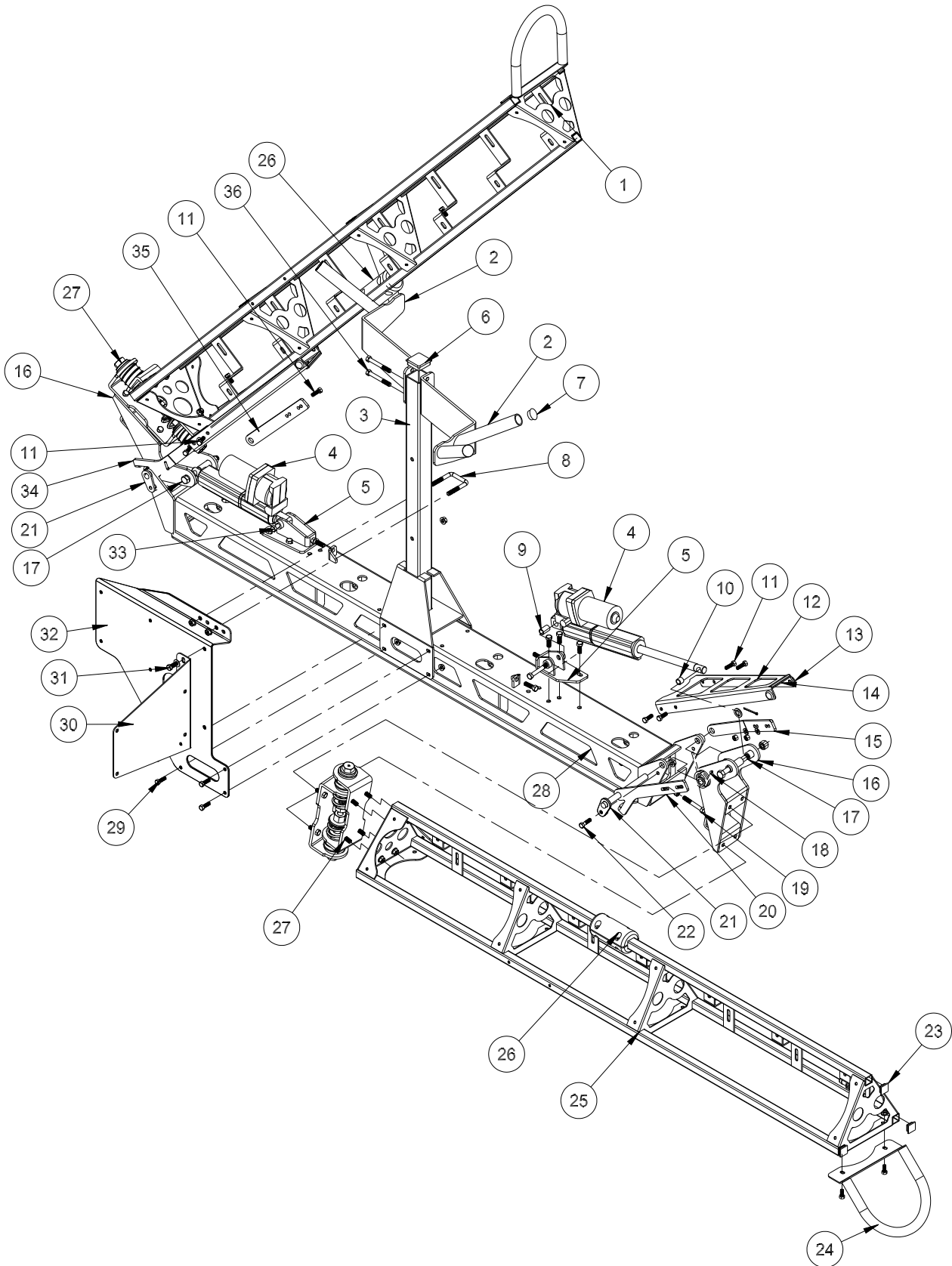

ACCESSORIES

17-580 20' BOOM PARTS LIST

REF#	PART#	DESCRIPTION	QUANTITY
30	17-636	Fresh Water Tank Mount	1
31	HB-38-16-100	Hex Bolt, $\frac{3}{8}$ - 16 x 1	2
	HNFL-38-16	Flange Whiz-loc Nut, $\frac{3}{8}$ - 16	2
	HW-38	Flat Washer, $\frac{3}{8}$	2
32	17-635	Clean Load Mount	1
	8803-13	Black Trim, 13"	1
33	HB-12-13-300	Hex Bolt, $\frac{1}{2}$ - 13 x 3	2
	HNTL-12-13	Nylon Lock Nut, $\frac{1}{2}$ - 13	2
34	17-593	Limit Hinge, LH	1
	17-598	Torsion Spring, LH	1
35	17-592	Lock Hinge, LH	1
36	HB-38-16-300	Hex Bolt, $\frac{3}{8}$ - 16 x 3	2
	HNTL-38-16	Nylon Lock Nut, $\frac{3}{8}$ - 16	2

BOOM MOUNT TO TRUCK

REF#	PART#	DESCRIPTION	QUANTITY
A		Center Boom Mount	1
B	17-614	Boom Spacer	2
C	HB-516-18-100	Hex Bolt, $\frac{5}{16}$ - 18 x 1	12
	HNTL-516-18	Nylon Lock Nut, $\frac{5}{16}$ - 18	12
D	20-555	U-Hex Bolt	4
	HNFL-12-13	Flange Whiz-loc Nut, $\frac{1}{2}$ - 13	8

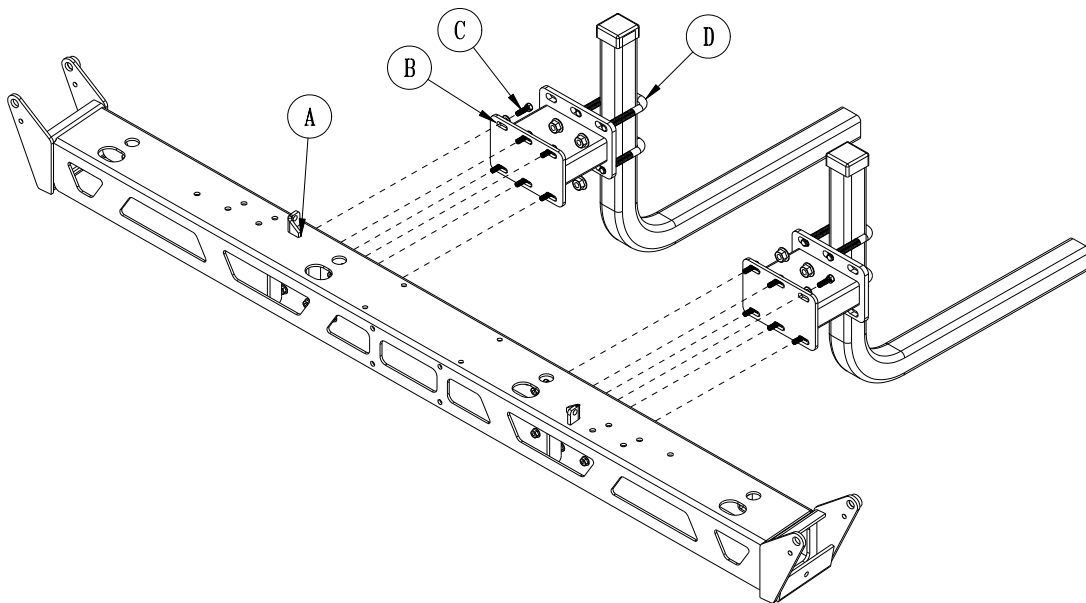

17-580 20' HD BOOM 1202/1204 PLUMBING

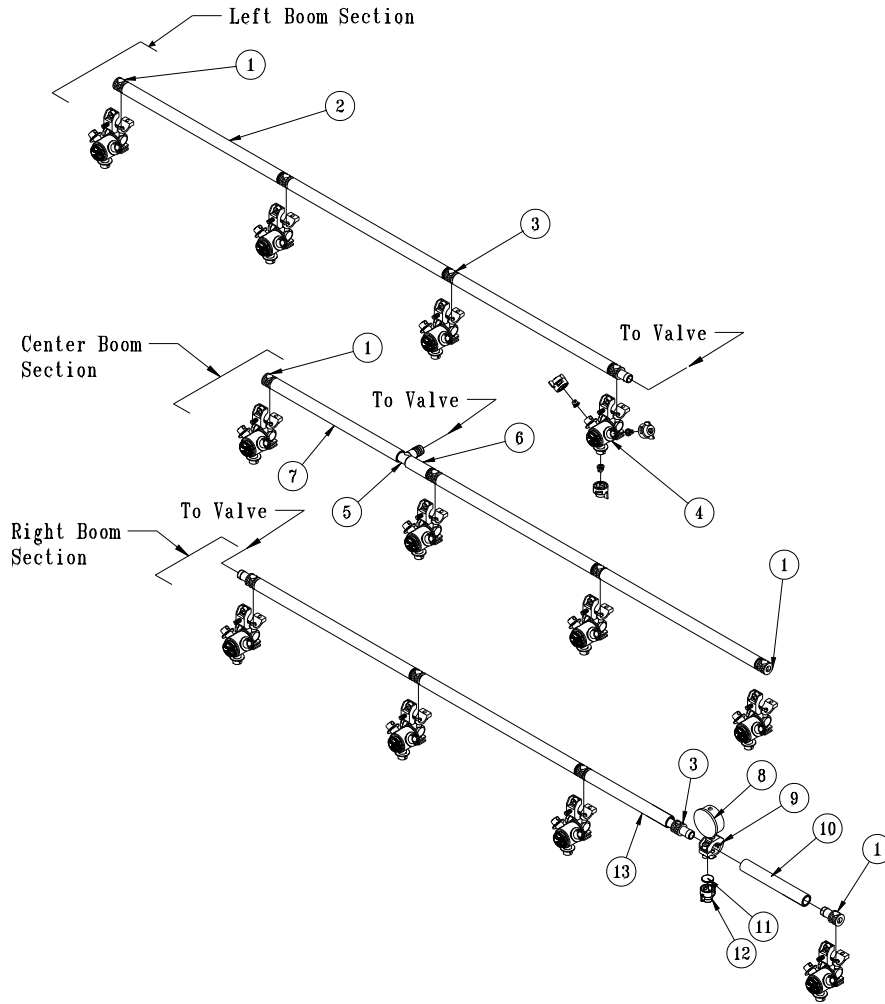

REF#	PART#	DESCRIPTION	QUANTITY
1	18-417	Single Barb	4
2	9032-19	Black Hose, $\frac{3}{4}$ " x 19"	7
	18-040	Hose Clamp	14
3	18-416	Double Barb	9
4	33-506	Nozzle body (see nozzle drawing)	12
5	18-415	$\frac{3}{4}$ " Hose Barb	1
6	9032-2.5	Black Hose $\frac{3}{4}$ " x 2 $\frac{1}{2}$ "	1
	18-040	Hose Clamp	2
7	9032-15.5	Black Hose $\frac{3}{4}$ " x 15 $\frac{1}{2}$ "	1
	18-040	Hose Clamp	2
8	16-281	Gauge	1
9	17-602	Nozzle Body	1
10	9032-5	Black Hose $\frac{3}{4}$ " x 5"	1
	18-040	Hose Clamp	2
11	16-800	Strainer	1
12	16-921	Nozzle	1
13	9032-13	Black Hose $\frac{3}{4}$ " x 13"	1
	18-040	Hose Clamp	2

17-580 20' HD BOOM 1207 PLUMBING

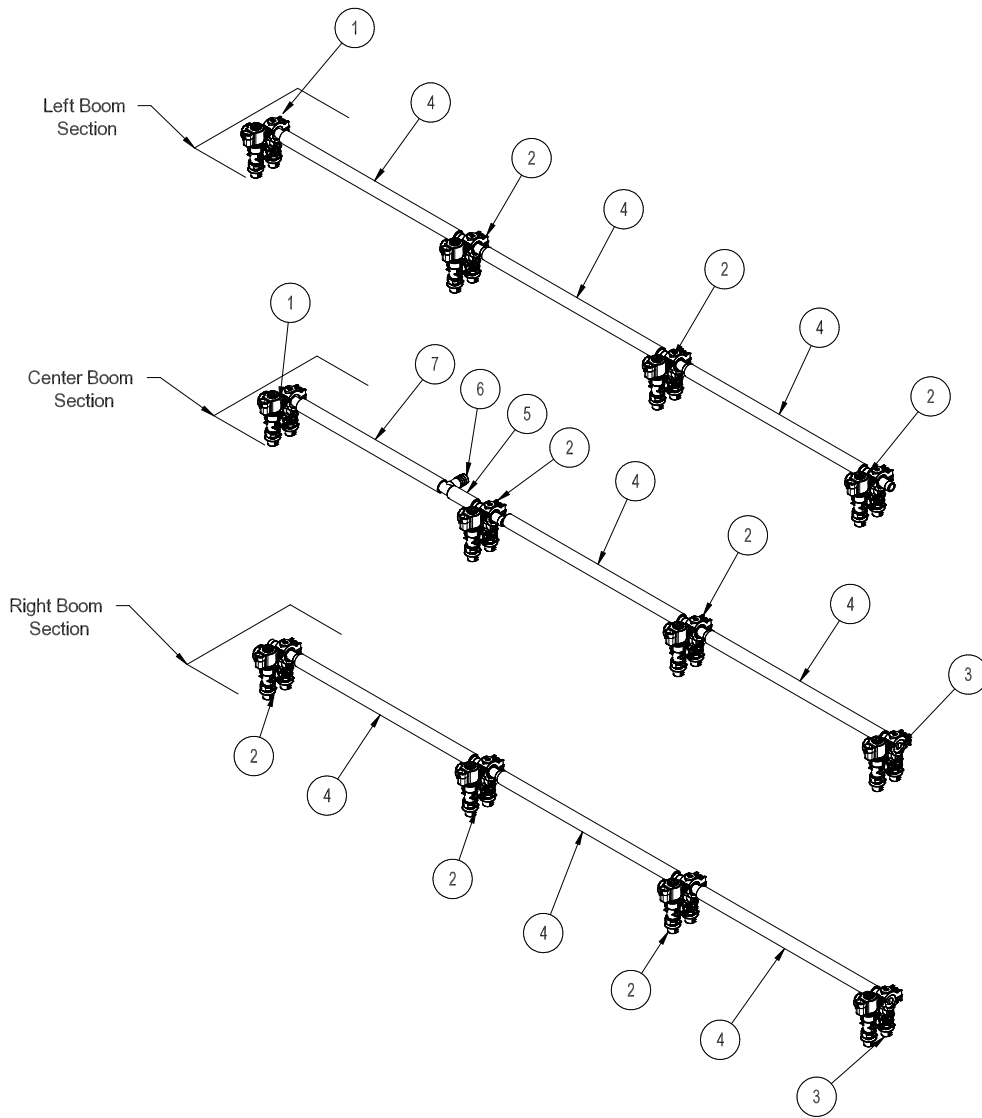

REF#	PART#	DESCRIPTION	QUANTITY
1	20-675	Single Hose Barb - Right Orientation	2
2	20-673	Single Hose Barb	8
3	20-674	Single Hose Barb - Left Orientation	2
4	9032-19	Black Hose, $\frac{3}{4}$ " x 19"	8
	18-040	Hose Clamp	16
5	9032-2.5	Black Hose, $\frac{3}{4}$ " x 2 $\frac{1}{2}$ "	1
	18-040	Hose Clamp	2
6	18-415	$\frac{3}{4}$ " Hose Barb	1
7	9032-15.5	Black Hose, $\frac{3}{4}$ " x 15 $\frac{1}{2}$ "	1
	18-040	Hose Clamp	2

17-580 20' HD BOOM 1220 PLUMBING

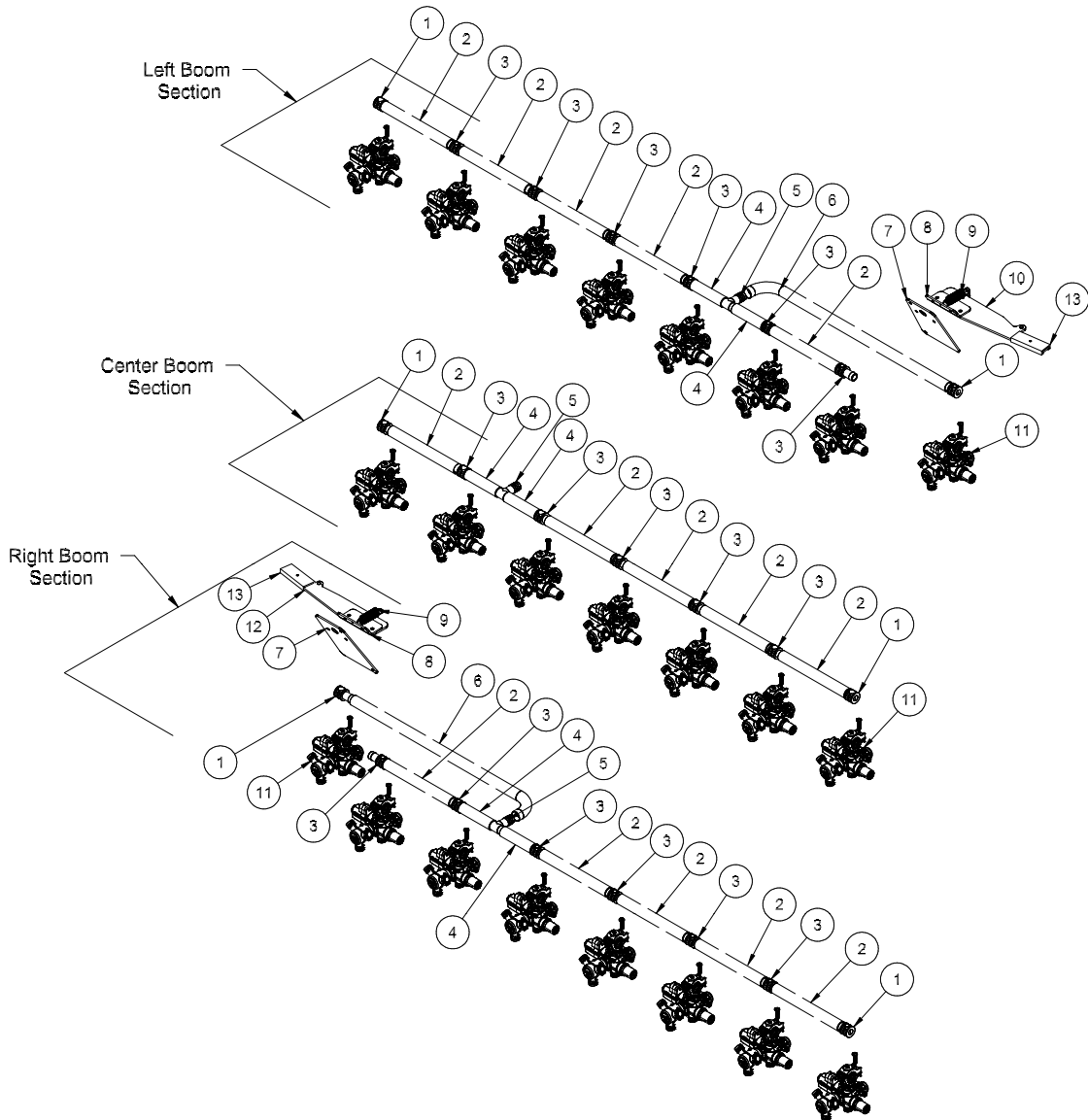

REF#	PART#	DESCRIPTION	QUANTITY
1	18-417	Single Barb	6
2	9032-8.5	Black Hose, $\frac{3}{4}$ " x 8.5"	15
	18-040	Hose Clamp	30
3	18-416	Double Barb	17
4	9032-4	Black Hose $\frac{3}{4}$ " x 4"	6
	18-040	Hose Clamp	12
5	18-415	$\frac{3}{4}$ " Hose Barb	3
6	9032-28	Black Hose $\frac{3}{4}$ " x 15 $\frac{1}{2}$ "	2
	18-040	Hose Clamp	4
7	17-559	Break-Away Mount	2
8	17-560	Hinge Mount	2
9	11-050	Spring	2
10	17-562	LH Break-Away Arm	1
11	20-807	Nozzle Body	23
12	17-561	RH Break-Away Arm	1

17-585 18' HD BOOM 1218 PLUMBING

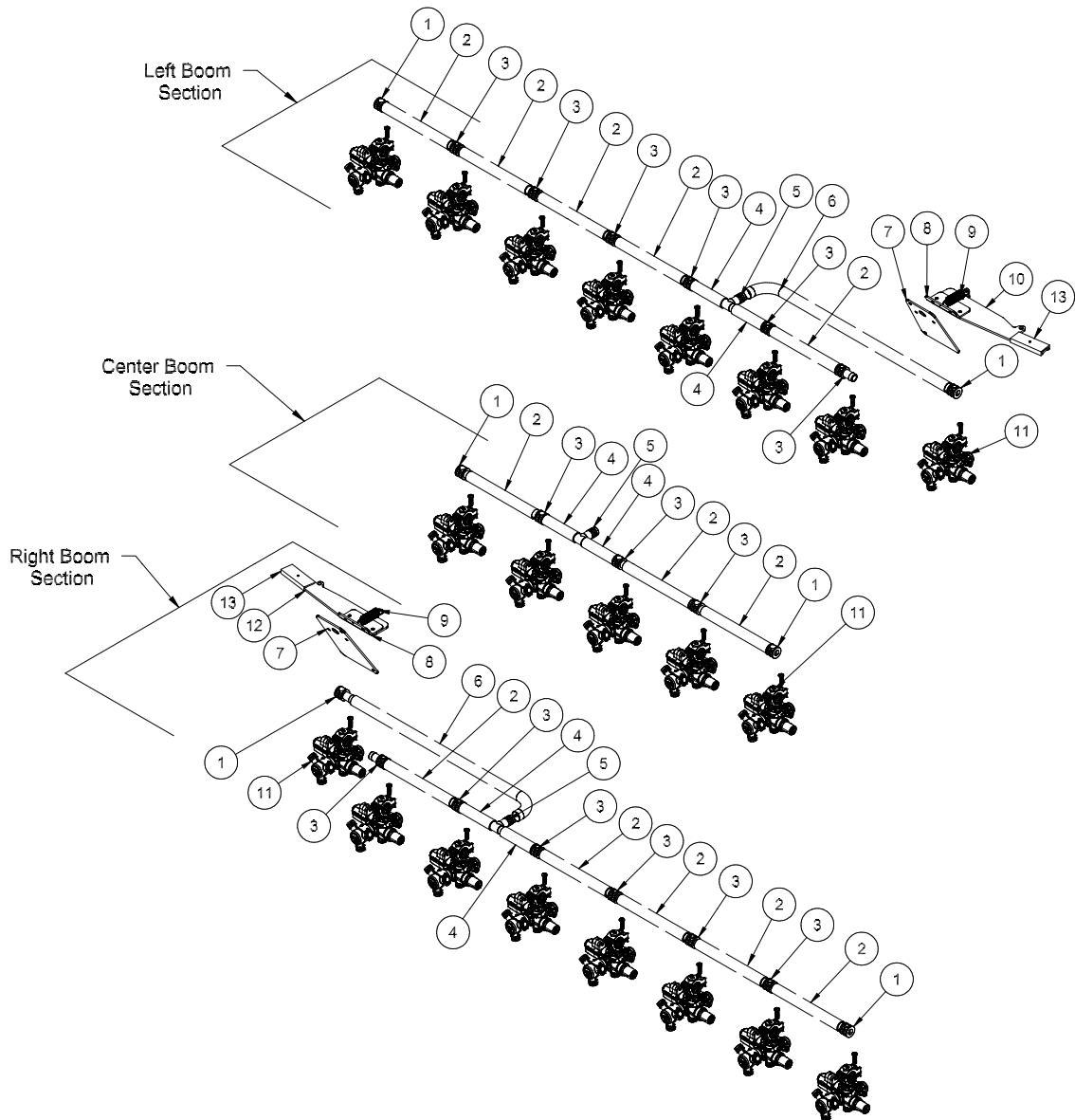

REF#	PART#	DESCRIPTION	QUANTITY
1	18-417	Single Barb	6
2	9032-8.5	Black Hose, $\frac{3}{4}$ " x 8.5"	13
	18-040	Hose Clamp	26
3	18-416	Double Barb	15
4	9032-4	Black Hose $\frac{3}{4}$ " x 4"	6
	18-040	Hose Clamp	12
5	18-415	$\frac{3}{4}$ " Hose Barb	3
6	9032-28	Black Hose $\frac{3}{4}$ " x 15 $\frac{1}{2}$ "	2
	18-040	Hose Clamp	4
7	17-559	Break-Away Mount	2
8	17-560	Hinge Mount	2
9	11-050	Spring	2
10	17-562	LH Break-Away Arm	1
11	20-807	Nozzle Body	21
12	17-561	RH Break-Away Arm	1

17-585 18' HD BOOM DRAWING

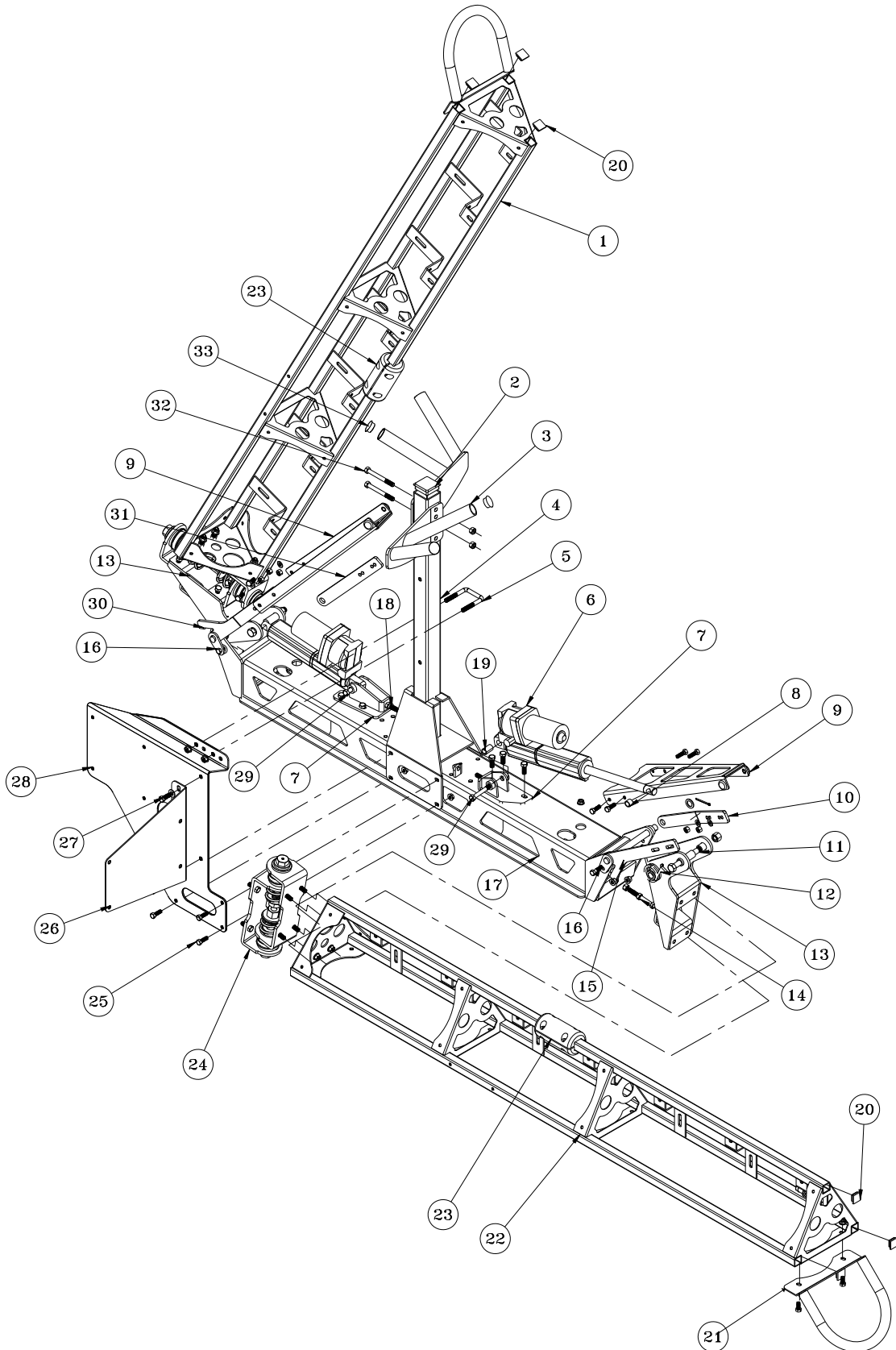

Accessories

17-585 18' HD BOOM PARTS LIST

REF#	PART#	DESCRIPTION	QUANTITY
1	17-652	Left Boom Arm	1
2	18-297	Cap Plug	1
3	17-617	Boom Nest	2
4	17-578	Boom Nest Post	1
5	17-537	Square U-Hex Bolt	1
6	30-214	KYB Electric/ Hydraulic Actuator (includes * items)	2
7	30-184	Ram Mount	2
	HN-38-16	Hex Nut, $\frac{3}{8}$ - 16 (for adjustment Hex Bolts)	4
	HB-38-16-100	Hex Bolt, $\frac{3}{8}$ - 16 x 1	6
	HW-38	Flat Washer, $\frac{3}{8}$	6
	HNFL-38-16	Flange Whiz-loc Nut, $\frac{3}{8}$ -16	6
8*	18-036	$\frac{1}{2}$ " Bushing (part of 30-214)	2
9	17-587	Boom Lock	2
	HB-516-18-100	Hex Bolt, $\frac{5}{16}$ - 18 x 1	8
	HW-516	Flat Washer, $\frac{5}{16}$	4
	HNTL-516-18	Nylon Lock Nut, $\frac{5}{16}$ -18	8
	42-116	Rubber Insert	4
	8803-2.75	Trim Lace, 2.75"	2
10	17-588	Lock Hinge, RH	1
11	HB-12-13-500	Hex Bolt, $\frac{1}{2}$ - 13 x 5	2
	HNTL-12-13	Nylon Lock Nut, $\frac{1}{2}$ - 13	2
12	17-597	Torsion Spring, RH	1
13	30-185	Arm Pivot Hinge	2
	HG-14-28-180	Grease Fitting, $\frac{1}{4}$ - 28 x 180°	2
	76-128	Bushing (part of 30-185)	4
14	HB-38-16-175	Hex Bolt, $\frac{3}{8}$ - 16 x $1\frac{3}{4}$	2
	HNFL-38-16	Flange Whiz-loc Nut, $\frac{3}{8}$ - 16	4
15	17-589	Limit Hinge, RH	1
16	17-596	Hinge Pin w/ Spacer	2
	HP-18-100	Cotter Pin $\frac{1}{8}$ x 1	2
	HB-516-18-100	Hex Bolt, $\frac{5}{16}$ - 18 x 1	2
	HNFL-516-18	Flange Whiz-loc Nut, $\frac{5}{16}$ -18	2
17	17-650	Boom Center	1
18	HB-38-16-100	Hex Bolt, $\frac{3}{8}$ - 16 x 1	2
	HNFL-38-16	Hex Nut, $\frac{3}{8}$ - 16	4
19*	18-234	1" Bushing (part of 30-214)	2
20	30-258	Ribbed 1" Plug	10
21	17-541	Boom End Guard	2
	HBFL-516-18-075	Hex Bolt, $\frac{5}{16}$ - 18 x $\frac{3}{4}$	4
	HNFL-516-18	Flange Whiz-loc Nut, $\frac{5}{16}$ - 18	4
22	17-653	Right Boom Arm	1
23	17-573	Guide Block Set	2
	HB-14-20-125	Hex Bolt, $\frac{1}{4}$ - 20 x $1\frac{1}{4}$	8
	HNTL-14-20	Nylon Lock Nut, $\frac{1}{4}$ - 20	8
24	17-632	Boom Hinge Complete	2
	HB-38-16-100	Hex Bolt, $\frac{3}{8}$ - 16 x 1	16
	HNFL-38-16	Flange Whiz-loc Nut, $\frac{3}{8}$ - 16	16
25	HB-516-18-100	Hex Bolt, $\frac{5}{16}$ - 18 x 1	8
	HW-516	Flat Washer, $\frac{5}{16}$	8
	HNFL-516-18	Flange Whiz-loc Nut, $\frac{5}{16}$ - 18	8

(Continue on next page)

17-585 18' HD BOOM DRAWING

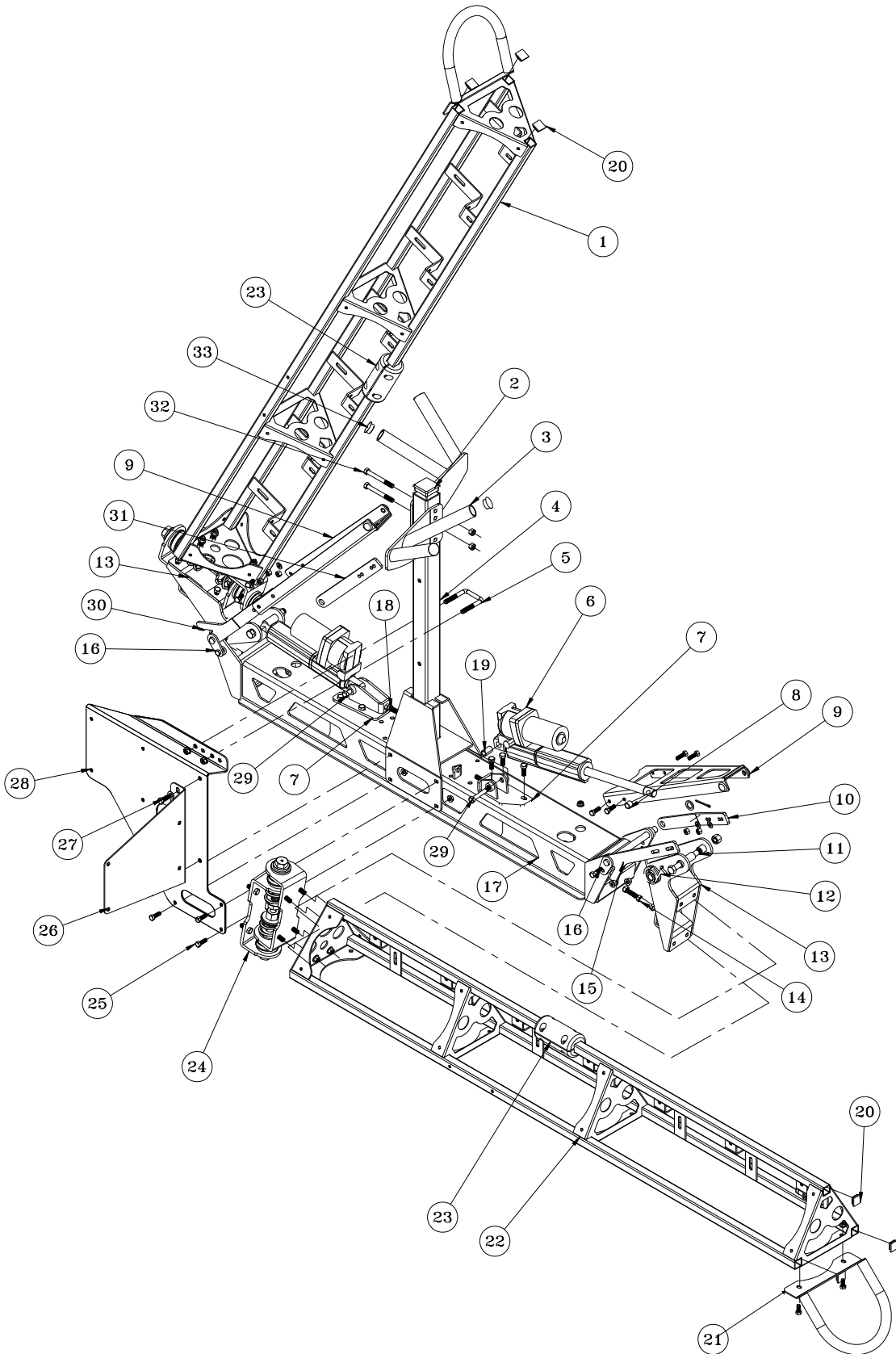

Accessories

17-585 18' HD BOOM PARTS LIST

REF#	PART#	DESCRIPTION	QUANTITY
26	17-636	Fresh Water Tank Mount	1
27	HB-38-16-100	Hex Bolt, $\frac{3}{8}$ - 16 x 1	2
	HNFL-38-16	Flange Whiz-loc Nut, $\frac{3}{8}$ - 16	2
	HW-38	Flat Washer, $\frac{3}{8}$	2
28	17-635	Clean Load Mount	1
	8803-13	Black Trim x 13"	1
29	HB-12-13-300	Hex Bolt, $\frac{1}{2}$ - 13 x 3	2
	HNTL-12-13	Nylon Lock Nut, $\frac{1}{2}$ - 13	2
30	17-593	Limit Hinge, LH	1
	17-598	Torsion Spring, LH	1
31	17-592	Lock Hinge, LH	1
32	HB-38-16-300	Hex Bolt, $\frac{3}{8}$ - 16 x 3	2
	HNTL-38-16	Nylon Lock Nut, $\frac{3}{8}$ - 16	2
33	17-619	Tube Cap	4

BOOM MOUNT TO TRUCK

REF#	PART#	DESCRIPTION	QUANTITY
A		Center Boom Mount	1
B	17-614	Boom Spacer	2
C	HB-516-18-100	Hex Bolt, $\frac{5}{16}$ -18 x 1	12
	HNTL-516-18	Nylon Lock Nut, $\frac{5}{16}$ -18	12
D	20-555	U-Hex Bolt	4
	HNFL-12-13	Flange Whiz-loc Nut, $\frac{1}{2}$ - 13	8

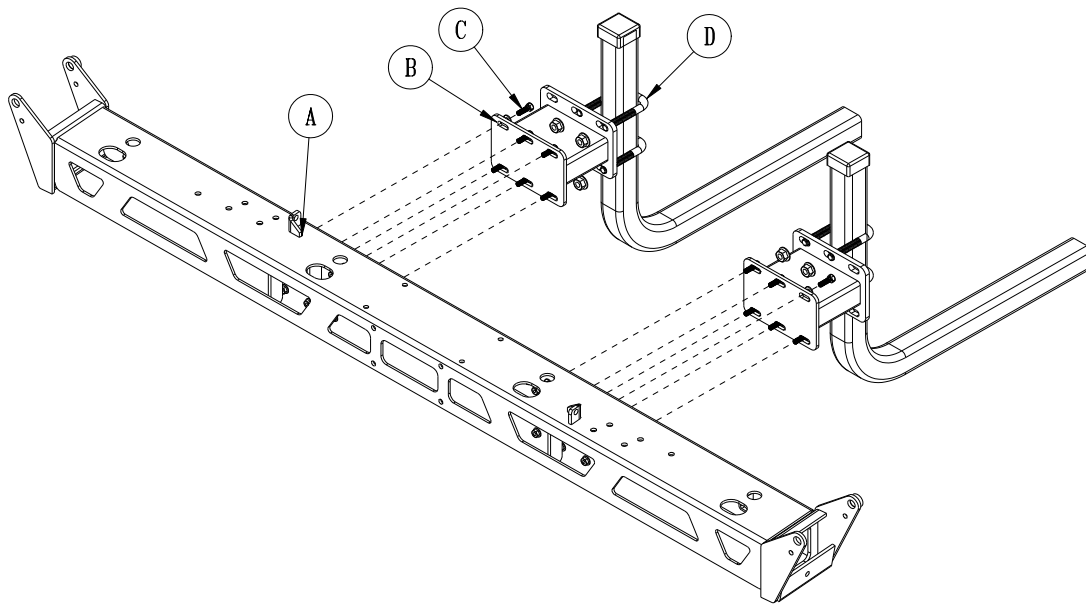

17-585 18' HD BOOM 1202/1204 PLUMBING

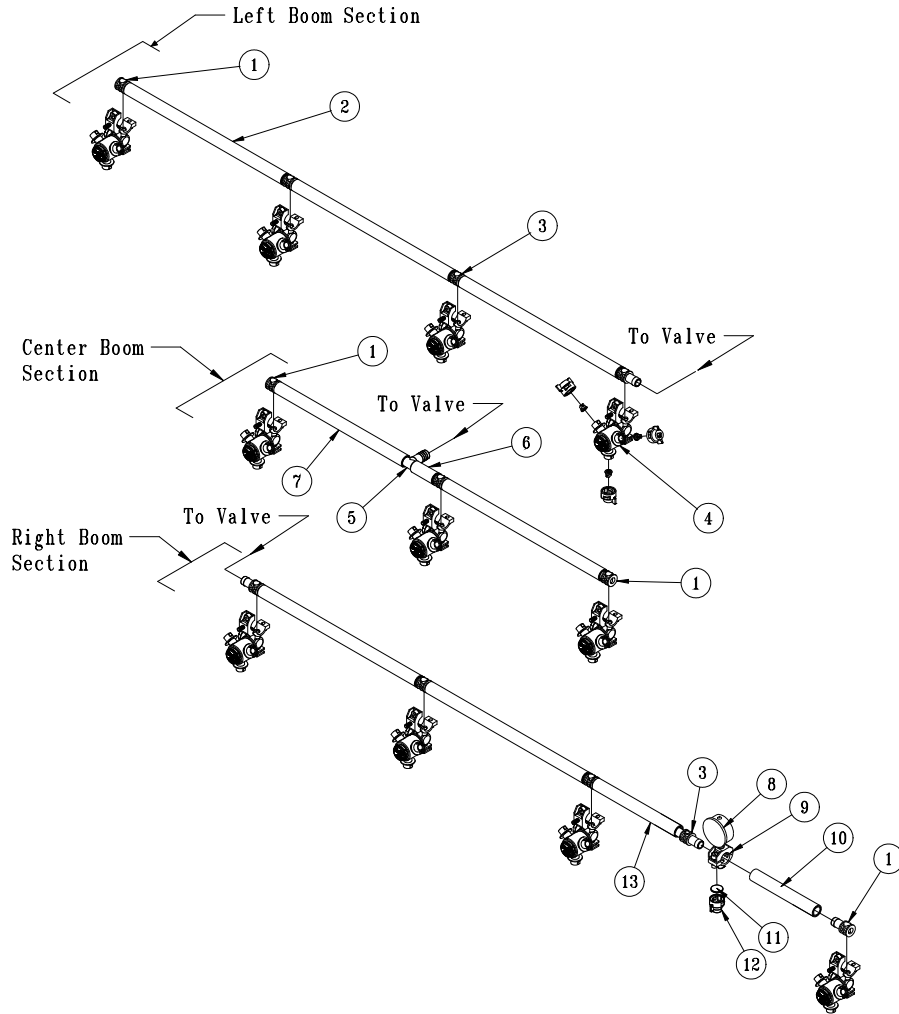

REF#	PART#	DESCRIPTION	QUANTITY
1	18-417	Single Barb	4
2	9032-19	Black Hose, 3/4" x 19"	6
	18-040	Hose Clamp	12
3	18-416	Double Barb	8
4	33-506	Nozzle body (see nozzle drawing)	11
5	18-415	3/4" Hose Barb	1
6	9032-2.5	Black Hose, 3/4" x 2 1/2"	1
	18-040	Hose Clamp	2
7	9032-15.5	Black Hose, 3/4" x 15 1/2"	1
	18-040	Hose Clamp	2
8	16-281	Gauge	1
9	17-602	Nozzle Body	1
10	9032-5	Black Hose, 3/4" x 5"	1
	18-040	Hose Clamp	2
11	16-800	Strainer	1
12	16-921	Nozzle	1
13	9032-13	Black Hose, 3/4" x 13"	1
	18-040	Hose Clamp	2

Accessories

17-585 18' HD BOOM 1208 PLUMBING

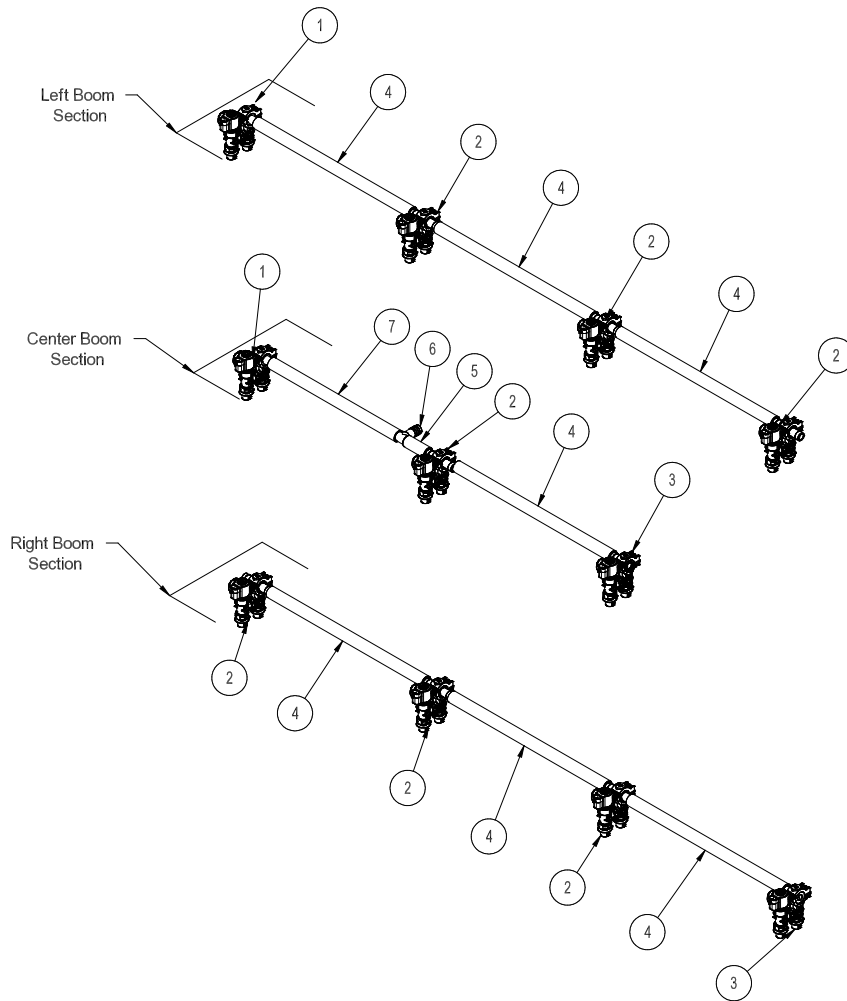

REF#	PART#	DESCRIPTION	QUANTITY
1	20-675	Single Hose Barb - Right Orientation	2
2	20-673	Single Hose Barb	8
3	20-674	Single Hose Barb - Left Orientation	2
4	9032-19	Black Hose, $\frac{3}{4}$ " x 19"	7
	18-040	Hose Clamp	14
5	9032-2.5	Black Hose, $\frac{3}{4}$ " x 2 $\frac{1}{2}$ "	1
	18-040	Hose Clamp	2
6	18-415	$\frac{3}{4}$ " Hose Barb	1
7	9032-15.5	Black Hose, $\frac{3}{4}$ " x 15 $\frac{1}{2}$ "	1
	18-040	Hose Clamp	2

17-601 15' HD BOOM DRAWING

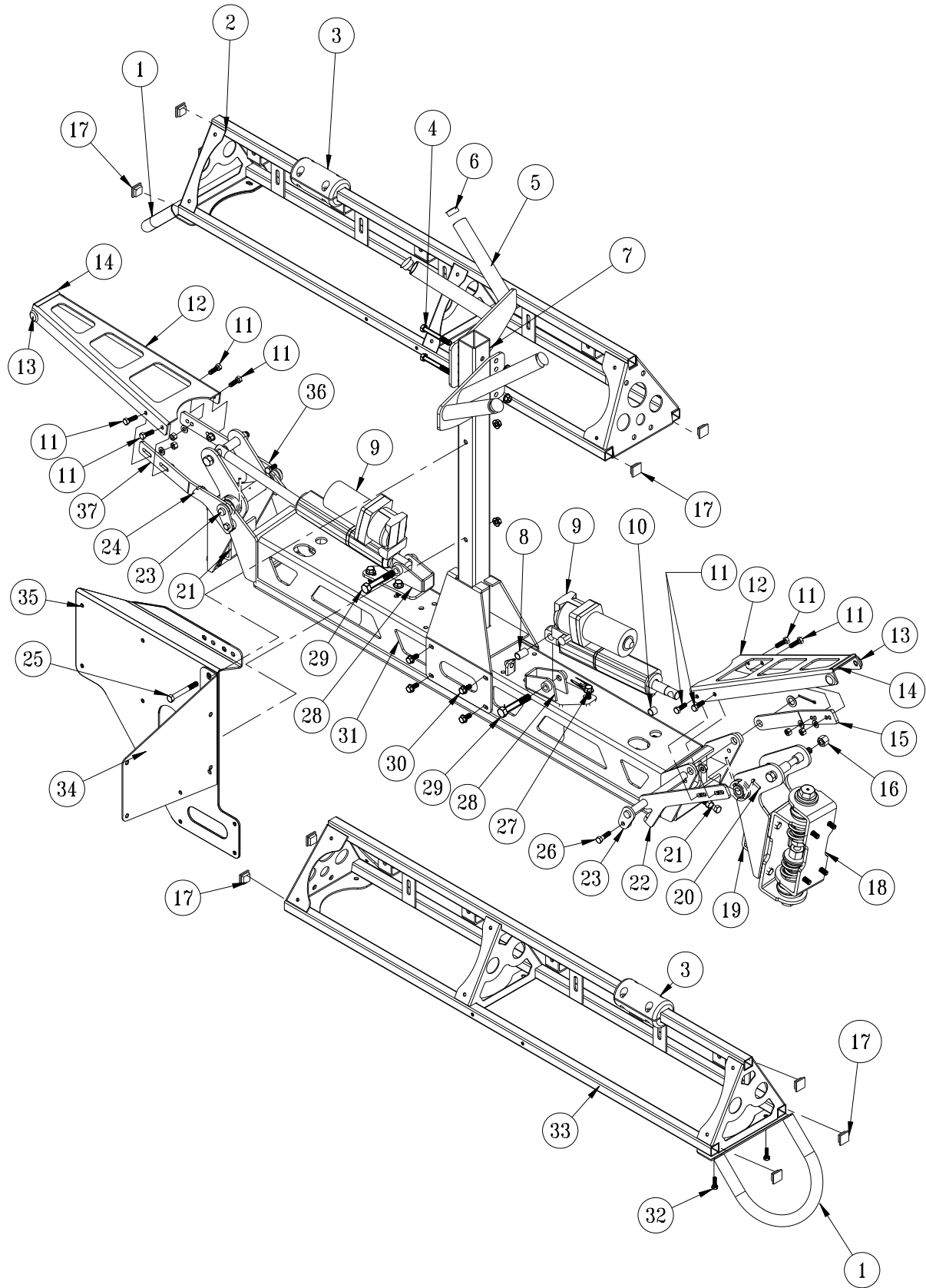

Accessories

17-601 15' HD BOOM PARTS LIST

REF#	PART#	DESCRIPTION	QUANTITY
1	17-541	Boom End Guard	2
2	17-551	Left Boom Arm	1
3	17-573	Guide Block Set	2
	HB-14-20-125	Bolt $\frac{1}{4}$ -20 x $1\frac{1}{4}$	8
	HNTL-14-20	Lock Nut $\frac{1}{4}$ - 20	8
4	HB-38-16-300	Bolt, $\frac{3}{8}$ - 16 x 3	2
	HNTL-38-16	Lock Nut, $\frac{3}{8}$ - 16	2
5	17-617	V-Boom Nest	2
6	17-619	Push-In Rounds	4
7	17-578	Boom Nest Post	1
	18-297	Cap Plug	1
8	18-036	1" Bushing (part of 30-214)	2
9	30-214	10" Electric/Hydraulic Actuator	2
10	18-234	$\frac{1}{2}$ " Bushing (part of 30-214)	2
11	HB-516-18-100	Bolt, $\frac{5}{16}$ -16 x 1	8
	HW-516	Flat Washer, $\frac{5}{16}$	4
	HNTL-516-18	Lock Nut, $\frac{5}{16}$ - 18	8
12	17-587	Boom Lock	2
13	42-116	Rubber Insert	4
14	8803-2.75	Trim Lace, $2\frac{3}{4}$	2
15	17-588	Lock Hinge, RH	1
16	HB-12-13-500	Bolt, $\frac{1}{2}$ - 13 x 5	2
	HNTL-12-13	Lock Nut, $\frac{1}{2}$ -13	2
17	30-258	1" 10-14ga Ribbed Plug	10
18	17-632	Boom Hinge Complete	2
	HB-38-16-100	Bolt, $\frac{3}{8}$ - 16 x 1	16
	HNFL-38-16	Lock Nut, $\frac{3}{8}$ - 16	16
19	30-185	Arm Pivot Hinge	2
	HG-14-28-180	Grease Fitting, $\frac{1}{4}$ - 28 x 180°	2
	76-128	Bushing (part of 30-185)	4
20	17-597	Torsion Spring, RH	1
21	HB-38-16-175	Bolt, $\frac{3}{8}$ - 16 x $1\frac{3}{4}$	2
	HNFL-38-16	Flange Lock Nut, $\frac{3}{8}$ - 16	4
22	17-589	Limit Hinge, RH	1
23	17-596	Hinge Pin w/Spacer	2
	HP-18-100	Cotter Pin, $\frac{1}{8}$ x 1	2
24	17-598	Torsion Spring, LH	1
25	HB-38-16-100	Bolt, $\frac{3}{8}$ - 16 x 1	2
	HW-38	Washer, $\frac{3}{8}$	2
	HNFL-38-16	Flange Lock Nut, $\frac{3}{8}$ - 16	2
26	HB-516-18-100	Bolt, $\frac{5}{16}$ -16 x 1	2
	HNFL-516-18	Flange Lock Nut, $\frac{5}{16}$ - 18	2
27	HB-38-16-100	Bolt, $\frac{3}{8}$ - 16 x 1	6
	HW-38	Washer, $\frac{3}{8}$	6
	HNFL-38-16	Flange Lock Nut, $\frac{3}{8}$ -16	6
28	30-184	Ram Mount	2
	HN-38-16	Nut, $\frac{3}{8}$ - 16 (on adjustment nuts)	4
29	HB-12-13-300	Bolt, $\frac{1}{2}$ - 13 x 3	2
	HNTL-12-13	Lock Nut, $\frac{1}{2}$ - 13	2
30	HB-516-18-100	Bolt, $\frac{5}{16}$ - 18 x 1	8
	HW-516	Washer, $\frac{5}{16}$	8
	HNFL-516-18	Flange Lock Nut, $\frac{5}{16}$ - 18	8

(Continued on next page)

17-601 15' HD BOOM DRAWING

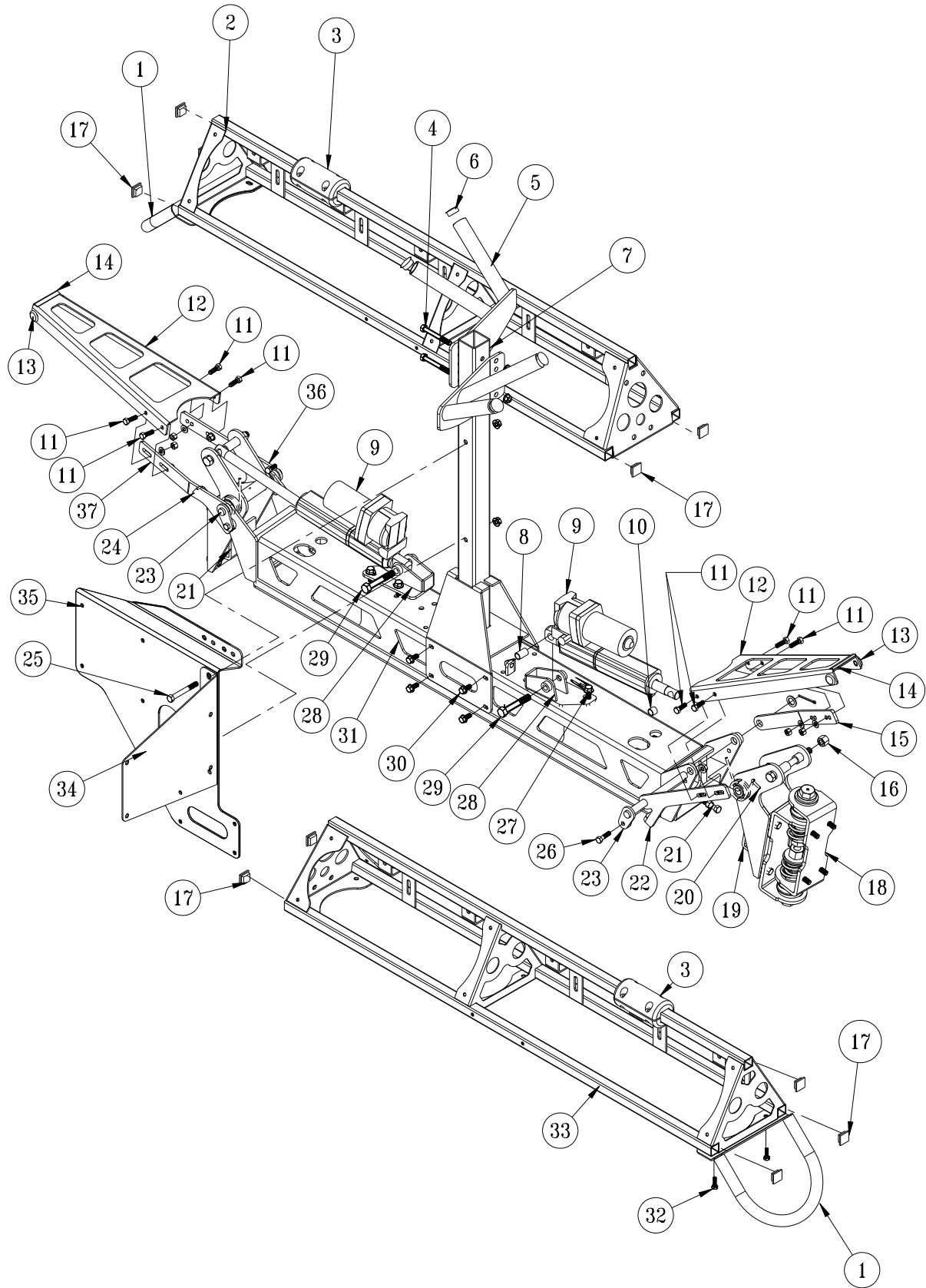

Accessories

17-601 15' HD BOOM PARTS LIST

REF#	PART#	DESCRIPTION	QUANTITY
31	17-528	Boom Center	1
	25-334	Decal, Serial Tag	1
32	HBFL-516-18-075	Bolt, $\frac{5}{16}$ - 18 x $\frac{3}{4}$	4
	HNFL-516-18	Flange Lock Nut, $\frac{5}{16}$ - 18	4
33	17-552	Right Boom Arm	1
34	17-636	Freshwater Mount	1
35	17-635	Clean Load Mount	1
	8803-13	Black Trim, 13"	
36	17-592	Lock Hinge, LH	1
37	17-593	Limit Hinge, LH	1
38	17-537	Square U-bolt	1
	HNCL-34-10	Center Lock Nut, $\frac{3}{4}$ -10	4
	HW-34	Flat Washer, $\frac{3}{4}$	4

BOOM MOUNT TO TRUCK

REF#	PART#	DESCRIPTION	QUANTITY
A		Center Boom Mount	1
B	17-614	Boom Spacer	2
C	HB-516-18-100	Hex Bolt, $\frac{5}{16}$ -18 x 1	12
	HNTL-516-18	Nylon Lock Nut, $\frac{5}{16}$ -18	12
D	20-555	U-Hex Bolt	4
	HNFL-12-13	Flange Whiz-loc Nut, $\frac{1}{2}$ - 13	8

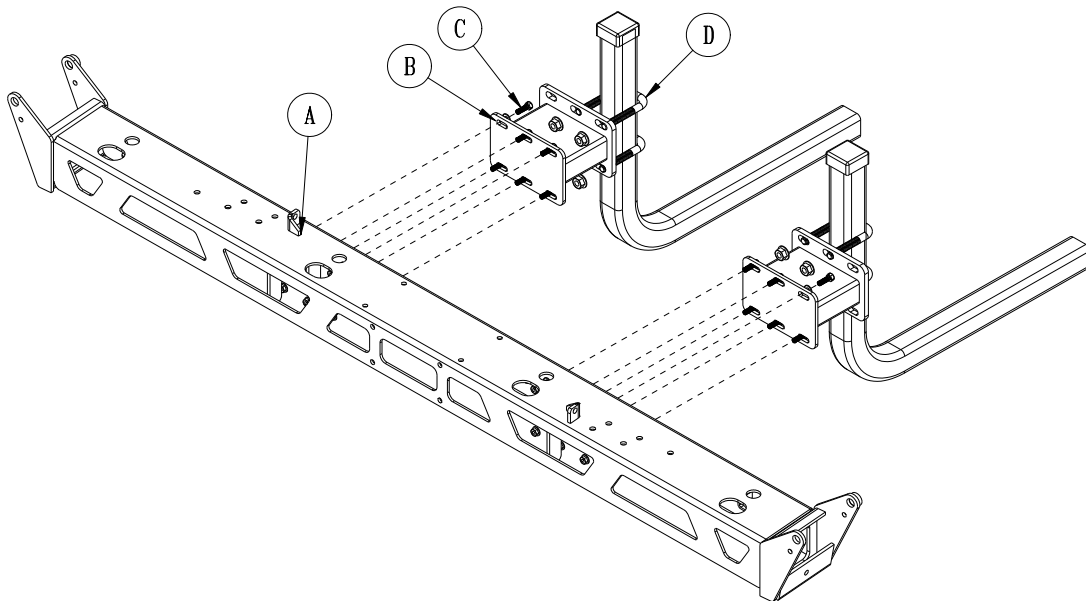

17-601 15' HD SUPER BOOM 1202/1204 PLUMBING

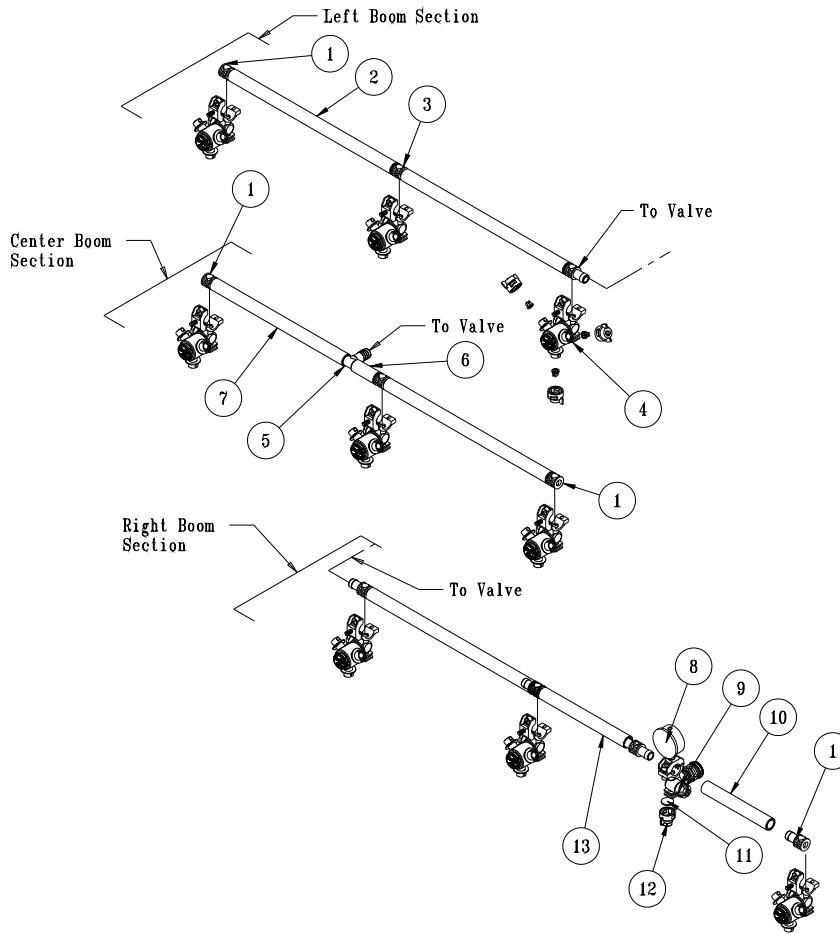

REF#	PART#	DESCRIPTION	QUANTITY
1	18-417	Single Barb	4
2	9032-19	Black Hose $\frac{3}{4}$ " x 19"	4
	18-040	Hose Clamp	8
3	18-416	Double Barb	6
4	33-506	Nozzle body (see nozzle drawing)	9
5	18-415	$\frac{3}{4}$ " Hose Barb	1
6	9032-2.5	Black Hose $\frac{3}{4}$ " x 2 $\frac{1}{2}$ "	1
	18-040	Hose Clamp	2
7	9032-15.5	Black Hose $\frac{3}{4}$ " x 15 $\frac{1}{2}$ "	1
	18-040	Hose Clamp	2
8	16-281	Gauge	1
9	17-602	Nozzle Body	1
10	9032-5	Black Hose $\frac{3}{4}$ " x 5"	1
	18-040	Hose Clamp	2
11	16-800	Strainer	1
12	16-921	Nozzle	1
13	9032-13	Black Hose $\frac{3}{4}$ " x 13"	1
	18-040	Hose Clamp	2

17-601 15' HD BOOM 1215 PLUMBING

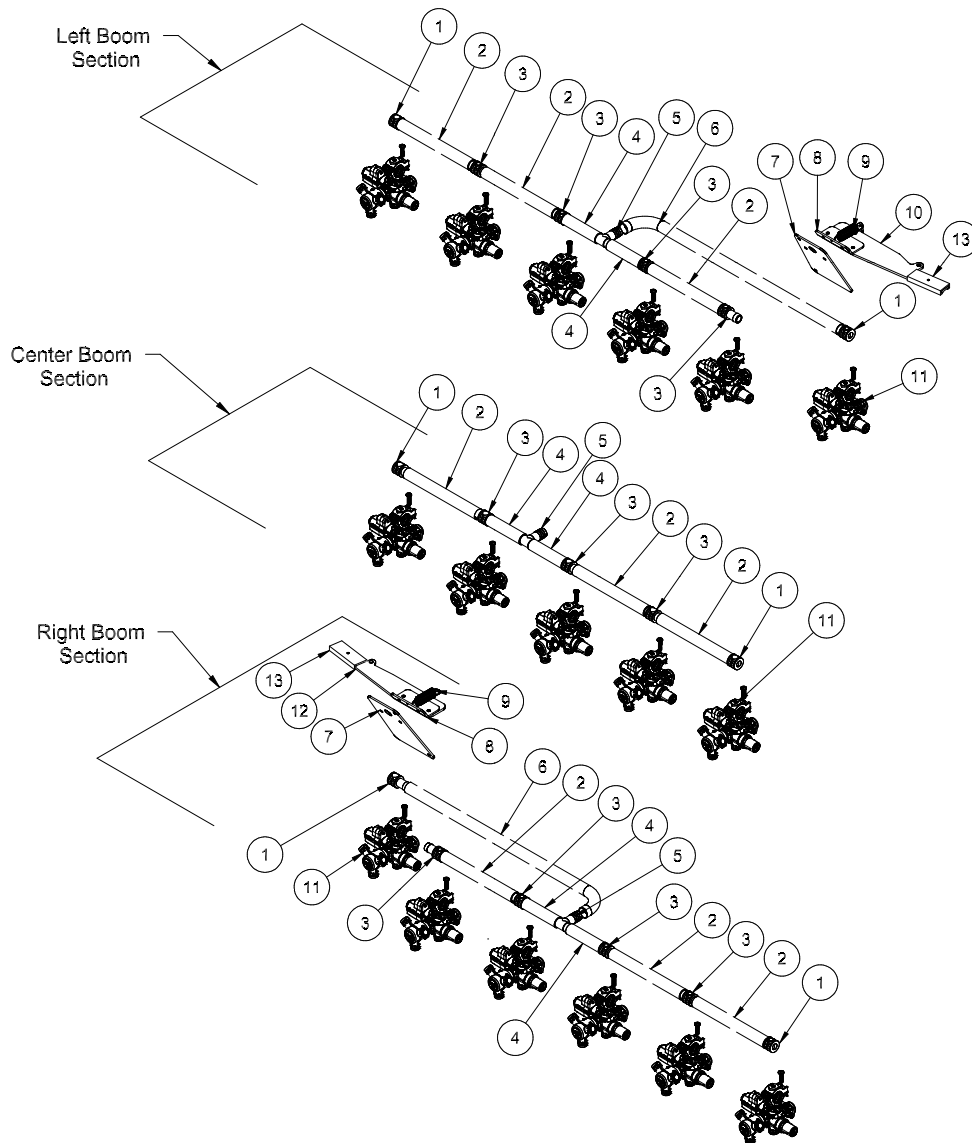

REF#	PART#	DESCRIPTION	QUANTITY
1	18-417	Single Barb	6
2	9032-8.5	Black Hose, $\frac{3}{4}$ " x 8.5"	9
	18-040	Hose Clamp	18
3	18-416	Double Barb	11
4	9032-4	Black Hose $\frac{3}{4}$ " x 4"	6
	18-040	Hose Clamp	12
5	18-415	$\frac{3}{4}$ " Hose Barb	3
6	9032-28	Black Hose $\frac{3}{4}$ " x 15 $\frac{1}{2}$ "	2
	18-040	Hose Clamp	4
7	17-559	Break-Away Mount	2
8	17-560	Hinge Mount	2
9	11-050	Spring	2
10	17-562	LH Break-Away Arm	1
11	20-807	Nozzle Body	17
12	17-561	RH Break-Away Arm	1

BOOM HINGE ASSEMBLED

2 HINGE ASSEMBLIES PER BOOM

*17-632-K Boom Hinge Complete

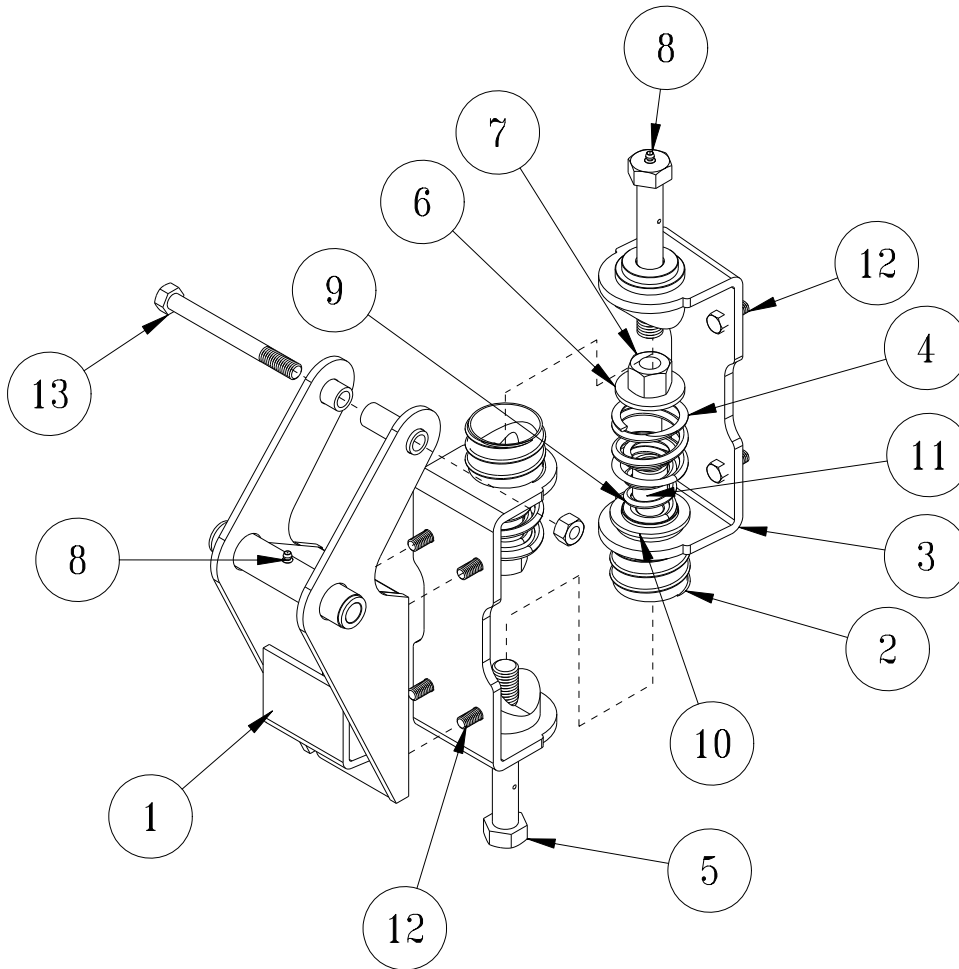

REF#	PART#	DESCRIPTION	QUANTITY
1	30-185	Arm Pivot Hinge (part of boom)	1
	HG-14-28-180	Grease Zerker (part of boom)	1
2*	9026-2	Rubber Duct Hose, 2"	2
3*	17-527	Boom Hinge	1
4*	17-539	Compression Spring	2
5*	17-540	Tapped Bolt	2
6*	HW-34	Flat Washer, 3/4	2
7*	HNCL-34-10	Center Lock Nut, 3/4 - 10	2
8*	HG-14-28-180	Grease Zerker	2
9*	17-591	Compression Spring	2
10*	17-599	Spring Shim	2
11*	17-594	Spring Sleeve	2
12*	HB-38-16-100	Hex Bolt, 3/8 - 16 x 1	8
	HNFL-38-16	Flange Lock Nut, 3/8 - 16	8
13	HB-12-13-500	Hex Bolt, 1/2 - 13 x 5	1
	HNTL-12-13	Lock Nut, 1/2 - 13	1

33-506 STANDARD NOZZLE ASSEMBLY

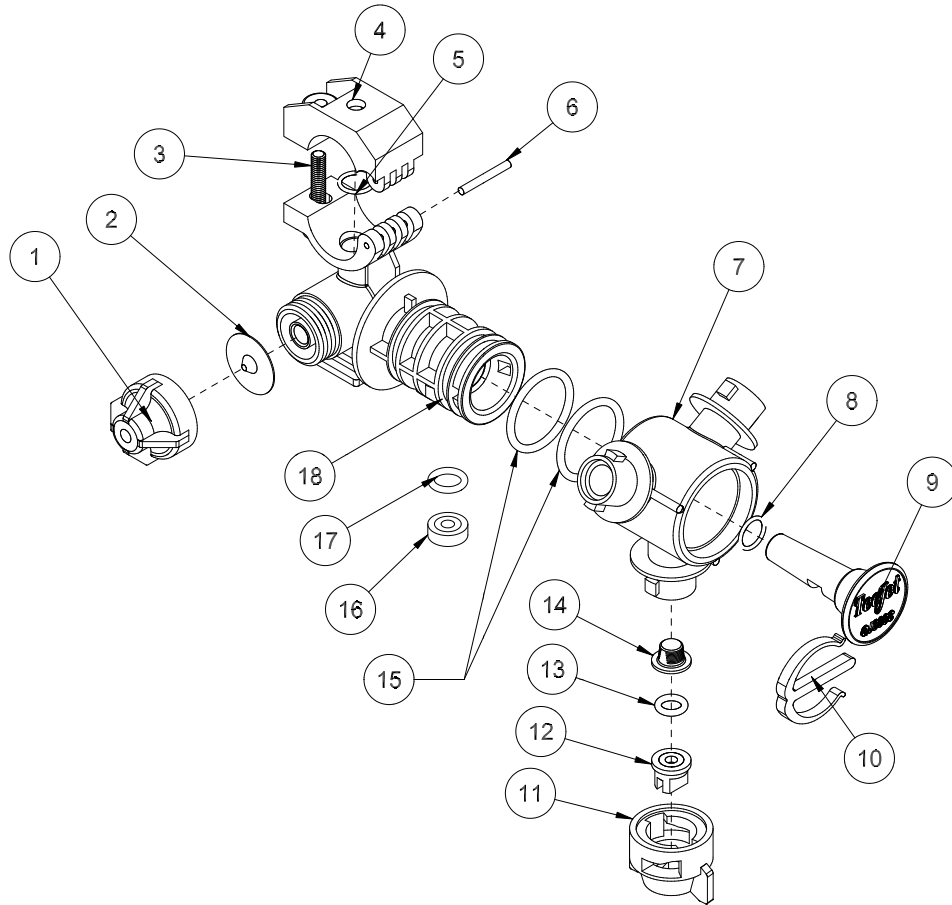

REF#	PART#	DESCRIPTION	QUANTITY
1*	16-988	Cap Assembly	1
2*	16-920-06	Diaphragm, EPDM	1
3*		Stainless Steel Screw	1
4*		Upper Clamp	1
5*	16-920-03	O-ring	1
6*		Pivot Pin, Stainless Steel	1
7*		Turret, 3-Outlet, Nylon	1
8*		O-ring, EPDM	1
9*		Plug	1
10*		E-clip	1
11	33-538	Cap - White	1
12	33-554	Nozzle Tip - White (XR11008-VS)	1
13	16-800	Viton Gasket	1
14	16-802	Strainer	1
15*		O-ring, Teflon	2
16*		O-ring, Viton	1
17*		Seal, Viton Teflon Filled	1
18*	33-506	Body Assembly (includes all * items)	1

Quantity is per nozzle body. For 20' booms multiply quantity by 12.

Quantity is per nozzle body. For 18' booms multiply quantity by 11.

Quantity is per nozzle body. For 18' booms multiply quantity by 9.

Nozzles are located 20" (51 cm) apart on the right, left, and center tubes.

Nozzles are 20" high off ground.

1207/1208 NOZZLE DRAWING

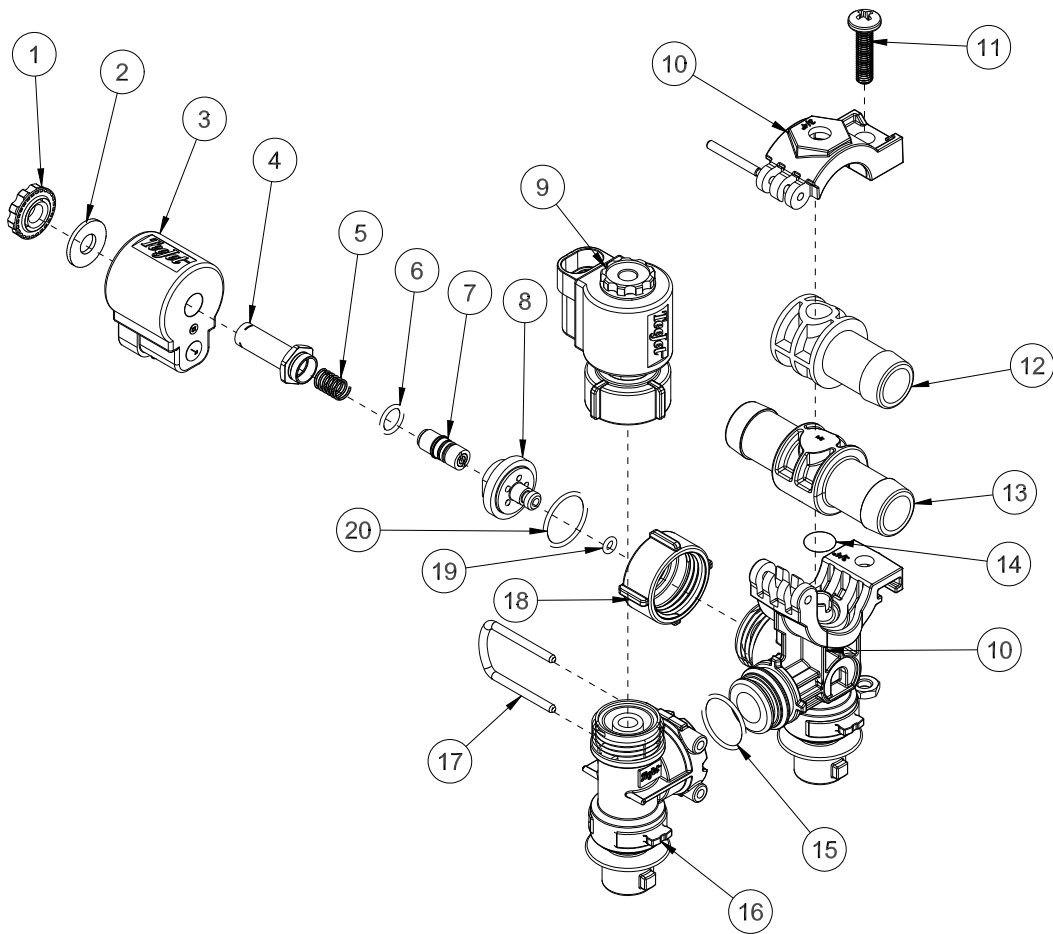

REF#	PART#	DESCRIPTION	QUANTITY
1		Nylon Black Nut	1
2		303 Stainless Steel Washer	1
3	20-673-09	12V Coil Assembly	1
4		Tube Sub Assembly	1
5*		302 Stainless Steel Spring	1
6*		Viton O-ring	1
7*		Plunger	1
8		303 Stainless Steel Cap	1
9	20-673-02	E-Chemsaver Solenoid	1
10	20-673-04	3/4" Mount Assembly	1
11		Pan Head Screw	1
12	18-417	Single Barb (part of 20-674-P and 20-675-P)	1
13	18-416	Double Barb (part of 20-673-P)	1
14	16-920-03	O-ring	1
15	20-673-11	O-ring	1
16	20-673-05	End Body Sub-assembly	1
17	20-673-08	Retaining Clip	1
18		Locking Ring	1
19*	20-673-07	Viton O-ring	1
20*	20-673-06	Viton Gasket	1
*	20-673-01	Spare Parts Kit	

Accessories

1207/1208 NOZZLE ASSEMBLY

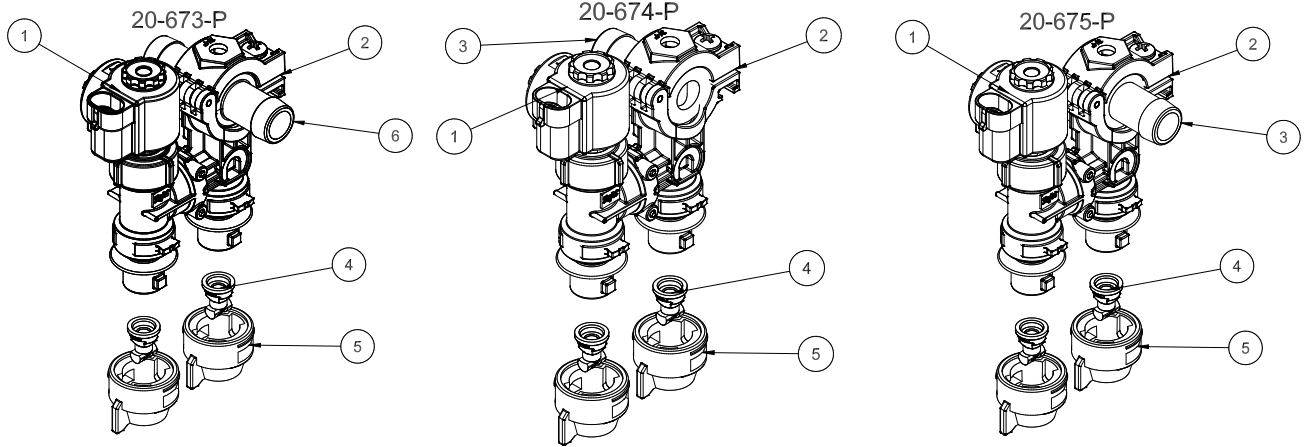

REF#	PART#	DESCRIPTION	QUANTITY
1*	20-673-02	E-Chemsaver®	1
2*	20-673-04	3/4" Bottom Mount Nozzle Body	1
3†	18-417	Single Barb	1
4	20-676	Turbo TeeJet Tip	2
5	20-677	QT White Cap and Washer	2
6‡	18-416	Double Hose Barb	1

Quantity is per nozzle body. For 18' booms multiply quantity by 11.
 Quantity is per nozzle body. For 20' booms multiply quantity by 12.

20-673	Double Hose Barb Nozzle (includes * and ‡ item)	8 or 9
20-674	Single Hose Barb Left Orientation (includes * and † item)	2
20-675	Single Hose Barb - Right Orientation (includes * and † item)	2

Nozzles are located 20" (51 cm) apart on the right, left, and center tubes. Nozzles are 20" high off ground.

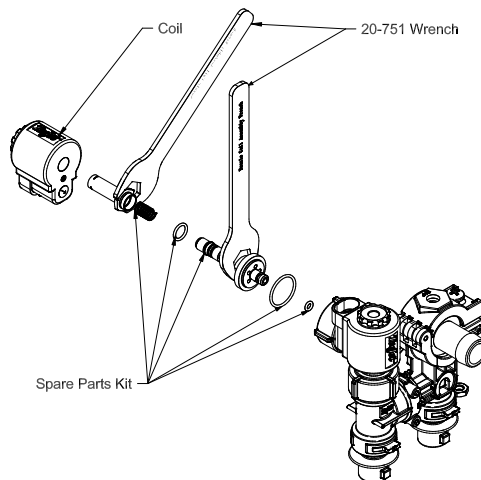

20-807 NOZZLE 1215/1218/1220 DRAWING

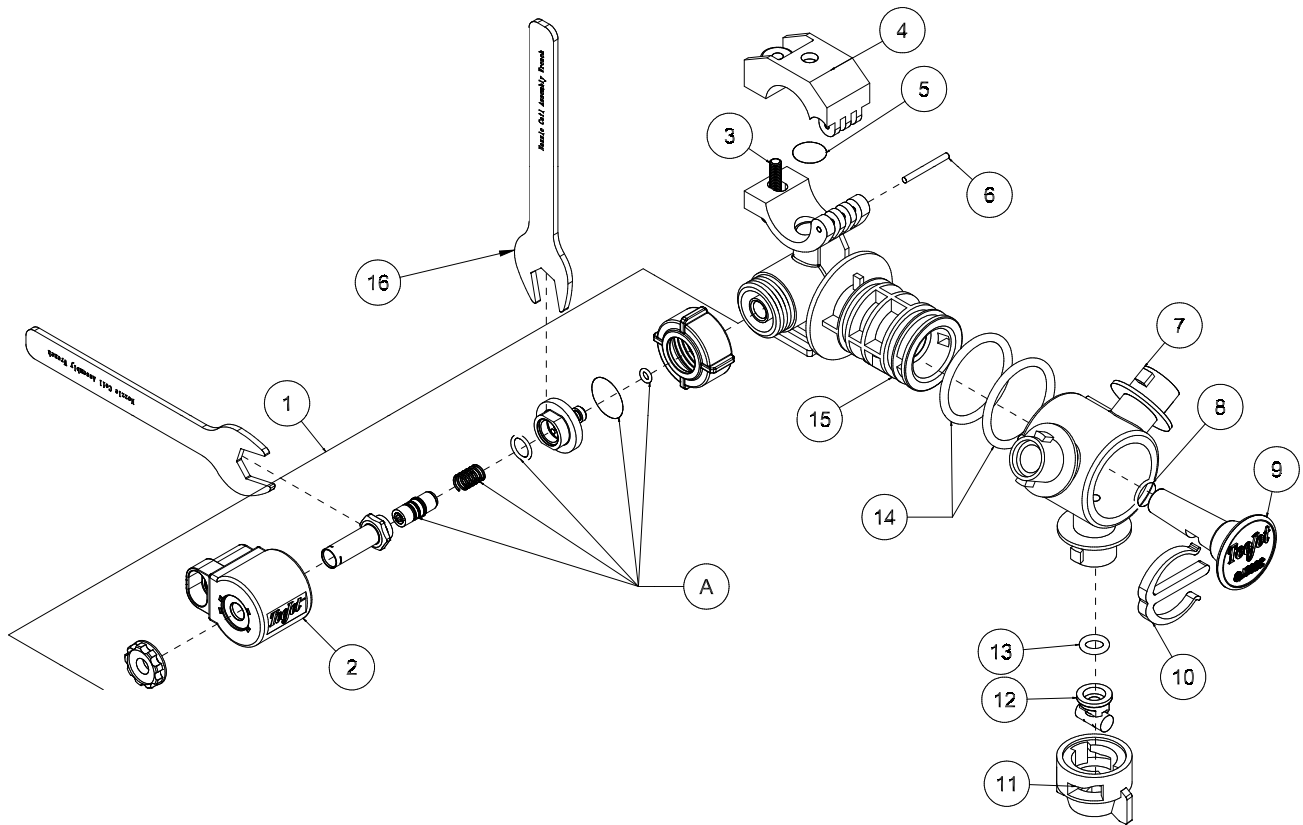

REF#	PART#	DESCRIPTION	QUANTITY
1	20-807-01	e-Chemsaver	1
2	20-673-09	12V Coil	1
3*		Stainless Steel Screw	1
4*		Upper Clamp	1
5*	16-920-03	O-ring	1
6*		Pivot Pin, Stainless Steel	1
7*		Turret, 3-Outlet, Nylon	1
8*		O-ring, EPDM	1
9*		Plug	1
10*		E-clip	1
11	20-838	Cap - Gray	1
12	20-837	Turbo Twinjet Nozzle Tip, Cap & Gasket - Gray	1
13	16-800	Viton Gasket	1
14	16-802	Strainer	1
15*		O-ring, Teflon	2
16*	33-506	Body Assembly (includes all * items)	1
A	20-807-02	Spare Parts Kit	

Quantity is per nozzle body. For 20' booms multiply quantity by 23.

Quantity is per nozzle body. For 18' booms multiply quantity by 21.

Quantity is per nozzle body. For 15' booms multiply quantity by 17.

Nozzles are located 10" (25 cm) apart on the right, left, and center tubes.

Nozzles are 20" high off ground.

15-835 TANK RINSING SYSTEM

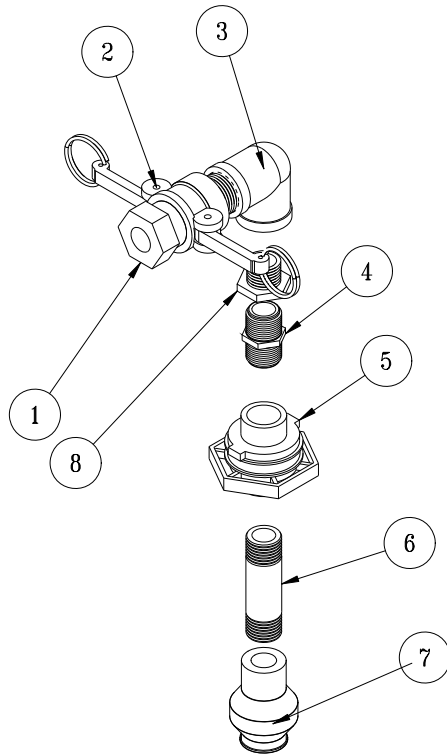

REF#	PART#	DESCRIPTION	QUANTITY
1	16-961	1" Adapter	1
2	16-962	1" Coupler	1
3	16-864	1" FTP Elbow	1
4	16-158	Close Nipple	1
5	16-150	Double Thread Fitting	1
6	16-172	4" Nipple	1
7	15-834	Tank Rinsing Nozzle	1
8	16-163	Reducer Bushing	1

Drill 1³/₄" hole 5" from outside edge of cover.
 Install Tank Rinsing kit as shown, with the Double Thread Fitting (Ref 5) going into the cover.

Basket Must be removed During Use.

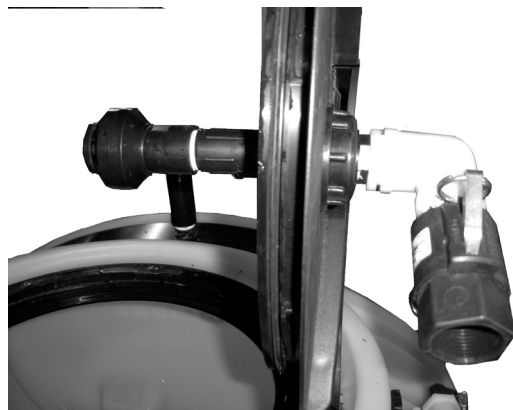

Accessories

16-906 ELECTRIC HOSE REEL DRAWING

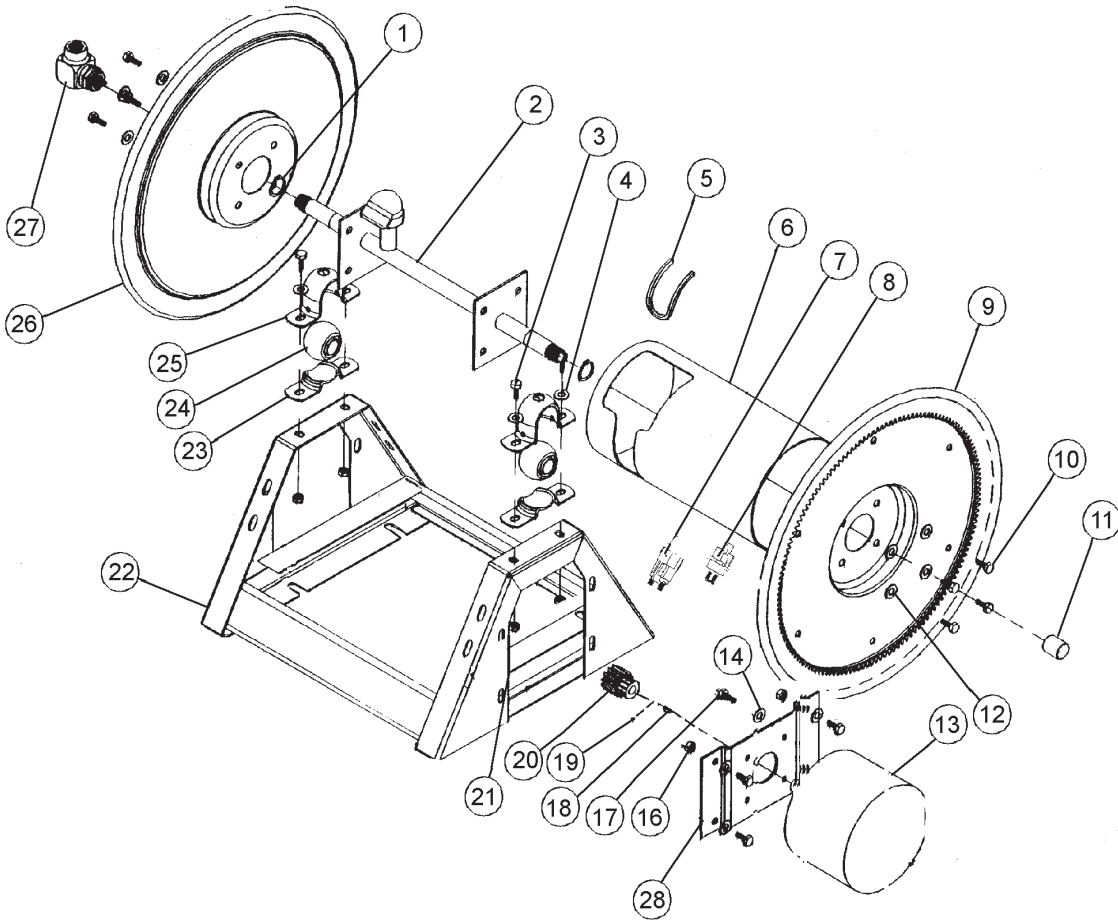

16-906 ELECTRIC HOSE REEL PARTS LIST

REF#	PART#	DESCRIPTION	QUANTITY
1	16-906-25	Retaining Ring	2
2	16-906-22	Axle Assembly	1
3	HB-38-16-100	Hex Bolt, $\frac{3}{8}$ - 16 x 1	4
4	HW-38	Flat Washer, $\frac{3}{8}$	4
5	16-906-27	Trim, Drum Edge	1
6	16-906-21	Drum Center	1
7	13-750	Solenoid	1
	HB-14-20-075	Hex Bolt, $\frac{1}{4}$ - 20 x $\frac{3}{4}$	2
	HWL-14	Lock Washer, $\frac{1}{4}$	2
	HN-14-20	Hex Nut, $\frac{1}{4}$ - 20	2
8	33-251	Switch	1
9	16-906-19	Disc and Gear Assembly	1
10	HB-516-18-075	Hex Bolt, $\frac{5}{16}$ - 18 x $\frac{3}{4}$	8
11	16-906-26	Pipe Cap, $\frac{3}{4}$	1
12	HWL-516	Lock Washer, $\frac{5}{16}$	8
13	16-906-15	$\frac{1}{3}$ HP Motor 12VDC	1
14	HW-516	Flat Washer, $\frac{5}{16}$	4
16	HNTL-516-18	Nylon Lock Nut, $\frac{5}{16}$ - 18	4
17	HB-516-18-100	Hex Bolt, $\frac{5}{16}$ -18 x 1	4
18	16-906-17	Key	1
19		Set Screw	2
20	16-906-29	Pinion	1
21	HNTL-38-16	Nylon Lock Nut, $\frac{3}{8}$ - 16	4
22	16-906-18	Frame Assembly	1
23	16-906-08	Mounting Pillow Block (Bottom)	2
24	16-906-24	Bearing	2
25	16-906-07	Mounting Pillow Block (Top)	2
26	16-906-20	Disc, 17 $\frac{1}{2}$ "	1
27	16-906-23	Swivel Assembly, $\frac{3}{4}$	1
	16-906-30	Seal Kit (For 16-906-23)	1
28	16-906-28	Bracket 12VDC	1
	16-982	Electric Hose Reel (only)	1

ELECTRIC HOSE REEL WIRING DIAGRAM

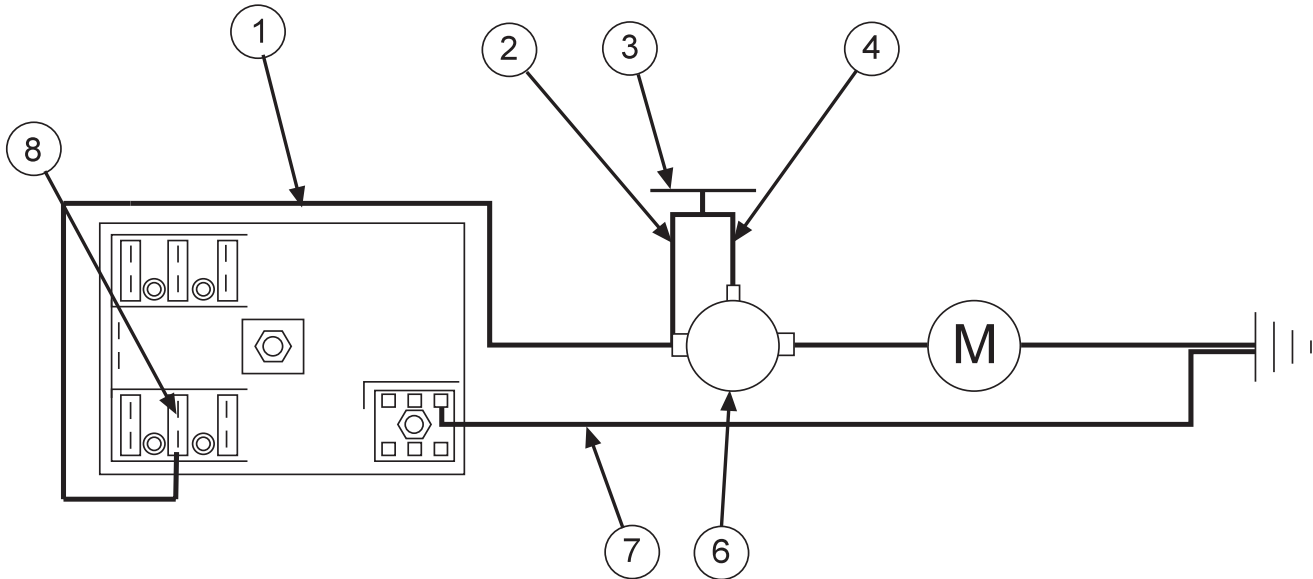

REF#	PART#	DESCRIPTION	QUANTITY
1	8843-132	Flex-guard $\frac{3}{8}$ ID	1
	8919-144	10GA Red Wire 144"	1
	8901	Slide-On Connector	1
2	16-979	Wire, Switch to Solenoid Hot Terminal	1
3	33-251	Push Button Switch	1
4	16-978	Wire, Switch to Solenoid Start Terminal	1
6	13-750	Solenoid	1

SOLENOID TERMINALS

	HN -516-24	$\frac{5}{16}$ - 24 Hex Nut	2
	HN -10-32	10 - 32 Hex Nut	1
7	8931-144	10GA White Wire 144"	1
	8901	Slide-On Connector	1
8	33-273	Auto Blade Type Fuse 30Amp	1

CONNECTION INSTRUCTIONS

Route wire harness along side of tank and over to fuse block taking care to stay clear of moving parts or hot engine components. Cut off excess wire and strip back $\frac{3}{8}$ ". Place one 8963 heat shrink ($\frac{1}{4} \times 1\frac{1}{4}$) on each wire before crimping 8901 slide on connectors to the red and white wires. Connect the two wires to the fuse block first the red to the (+) positive and the white to the (-) negative. Put the 33-273 auto blade type fuse (30 amp) into fuse block.

⚠ WARNING

Make certain you are connecting positive (+) to positive; negative (-) to negative while attaching power leads. If you do not observe polarity, damage will result to electrical components.

Use Dielectric Grease On All Electrical Connections

HOSE REEL ADJUSTMENTS

OPERATIONAL CHECK:

1. Pull hose off drum at least one full revolution. A clicking noise should be heard from locking mechanism.
2. Let the hose retract.
3. Pull the hose off until the first click is heard. Drum should lock when the hose tension is removed.
4. Continue pulling the hose, no more than one revolution, until no clicking is heard. Hose should rewind when tension is removed.

HOSE REPLACEMENT PROCEDURE:

1. Facing swivel, turn the hose drum clockwise until all of the hose is removed from the drum and the drum is held by locking mechanism. Make sure spring is locked.
2. Remove hose clamps and disconnect hose from swivel. Remove old hose.
3. Insert new hose through roller guide, connect to swivel and reinstall hose clamps. Use spring guard over hose to protect the hose from being cut by the drum.
4. Remove check ball from old hose and install on replacement hose.
5. Carefully, keeping the tension on the hose, pull the hose to release the locking mechanism. Let the hose wind on the drum.

16-129 MANUAL HOSE REEL DRAWING

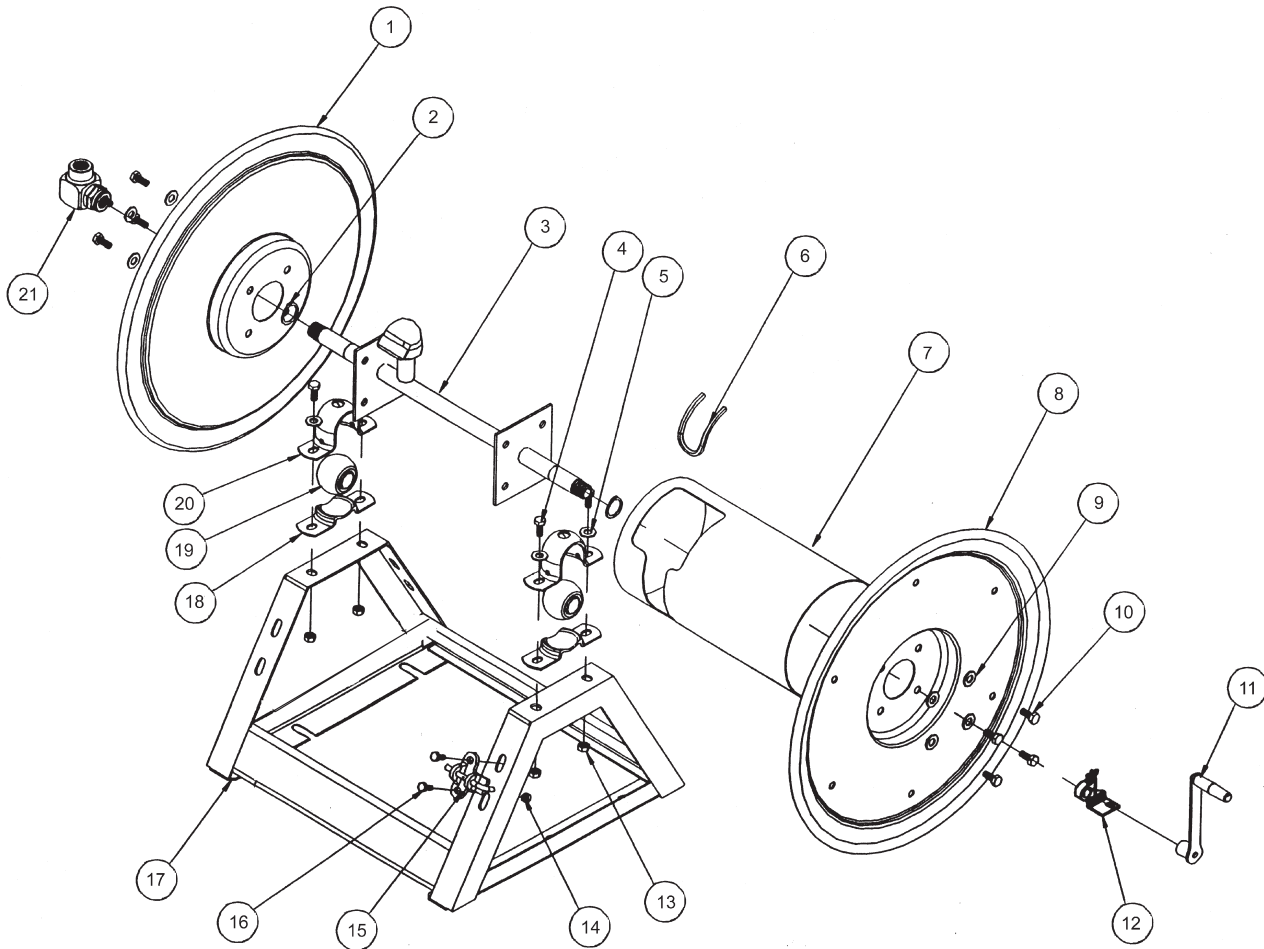

REF#	PART#	DESCRIPTION	QUANTITY
1	16-129-11	Disc 17 $\frac{1}{2}$	1
2	16-906-25	Retaining Ring	2
3	16-906-22	Axle Assembly $\frac{3}{4}$	1
4	HB-38-16-100	Hex Bolt $\frac{3}{8}$ - 16 x 1	4
5	HW-38	Washer $\frac{3}{8}$	4
6	16-906-27	Trim, Drum Edge	1
7	16-906-21	Drum Center	1
8	16-906-20	Disc 17 $\frac{1}{2}$, Crank Side	1
9	HWL-516	Lockwasher $\frac{5}{16}$	8
10	HB-516-18-075	Hex Bolt $\frac{5}{16}$ - 18 x $\frac{3}{4}$	8
11	16-129-09	Crank Assembly $\frac{3}{4}$	1
12	16-129-10	Brake Assembly $\frac{3}{4}$	1
13	HNTL-38-16	Nylon Lock Nut $\frac{3}{8}$ - 16	4
14	HNTL-516-18	Nylon Lock Nut $\frac{5}{16}$ - 18	2
15	16-129-03	Lock Pin Assembly	1
16	HB-516-18-075	Hex Bolt $\frac{5}{16}$ - 18 x $\frac{3}{4}$	2
	HW-516	Washer $\frac{5}{16}$	2
17	16-129-07	Frame Assembly	1
18	16-906-08	Mounting Pillow Block (Bottom)	2
19	16-906-24	Bearing	2
20	16-906-07	Mounting Pillow Block (Top)	2
21	16-906-23	Swivel Assembly $\frac{3}{4}$	1
	16-906-30	Seal Kit (For 16-906-23)	1

15-967 HOSE REEL MOUNT

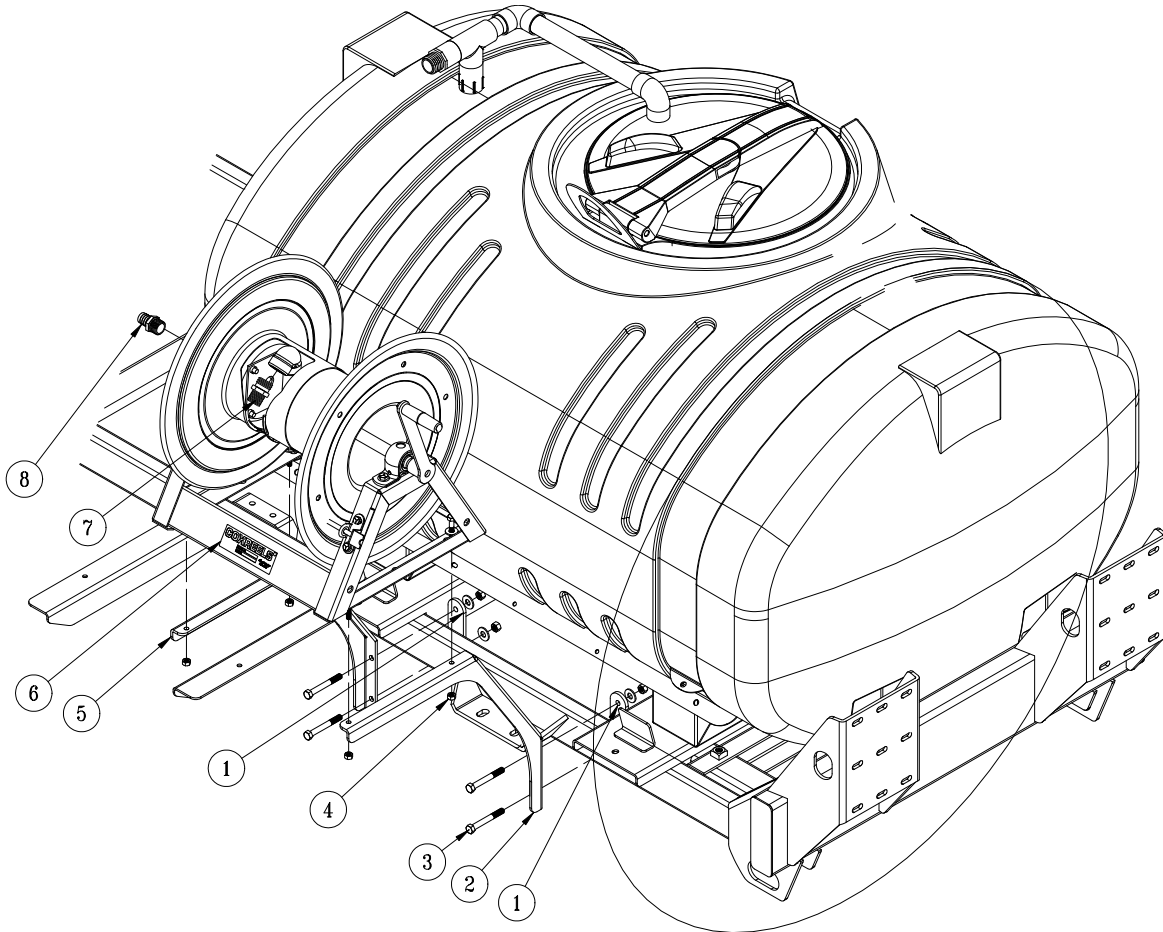

REF#	PART#	DESCRIPTION	QUANTITY
1	20-799	Backing Plate	2
2	20-788	Rear Hose Reel Mount	1
3	HB-38-16-300	Hex Bolt, $\frac{3}{8}$ - 16 x 3	4
	HNTL-38-16	Nylon Lock Nut, $\frac{3}{8}$ - 16	4
	HW-38	Flat Washer, $\frac{3}{8}$	4
4	HB-516-18-150	Hex Bolt, $\frac{5}{16}$ - 18 x $1\frac{1}{2}$	4
	HNTL-516-18	Nylon Lock Nut, $\frac{5}{16}$ - 18	4
	HW-516	Flat Washer, $\frac{5}{16}$	4
5	20-789	Front Hose Reel Mount	1
6	16-906	Electric Hose Reel	1
	16-129	Manual Hose Reel	1
7	16-295	Hose Fitting	1
8	18-249	Brass Fitting, $\frac{3}{4}$ MPT x $\frac{3}{4}$ HB	1

1. Wear protective clothing when draining the tank and taking apart the lines.
2. Drain tank and spray system in a safe and approved method ensuring that no chemical or water remain in tank as you will be taking apart lines.
3. Remove key from ignition, set park brake and block wheels.
4. Install Front Mount(Ref. 2) using Backing Plate(Ref. 1) and two $\frac{3}{8}$ x 3 Hex Bolts, Nuts and Washers. Repeat with Rear Mount(Ref. 5). Leave loose to reposition.
5. Position Hose Reel on Mounts. Use four Hex Bolts $\frac{5}{16}$ - 18 x $1\frac{1}{2}$ and four $\frac{5}{16}$ - 18 Nylon Lock Nuts to hold in place. Tighten Hex Bolts.
6. Tighten Mount Bolts(Ref 3).
7. Put 18-249 barb fitting(Ref. 8) into hose reel end and 16-295 hose fitting(Ref 7) into center of hose reel.

RADION HOSE REEL PLUMBING

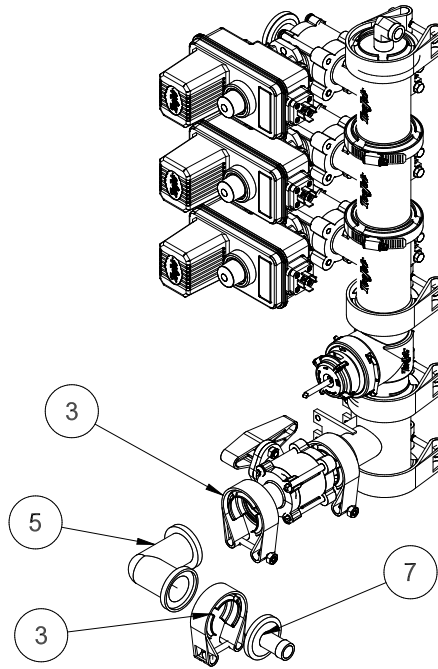

TEEJET RADION 8140

REF#	PART#	DESCRIPTION	QUANTITY
3	15-740	50 Series Clamp	3
5	15-736	#50 Elbow Coupling	1
7	15-749	Hose Barb	1

INSTALLATION INSTRUCTIONS

1. TeeJet 8140: Some machines have the ball valve already installed. Remove cover from the tee or the ball valve. Install the rest of the fittings as shown.
2. Route the $\frac{3}{4}$ " hose from the hose barb to the hose barb on the hose reel and secure with a 18-040 Hose clamp.
3. Secure the hose to the machine with a nylon tie strap.
4. There may be parts left over that you will not need.

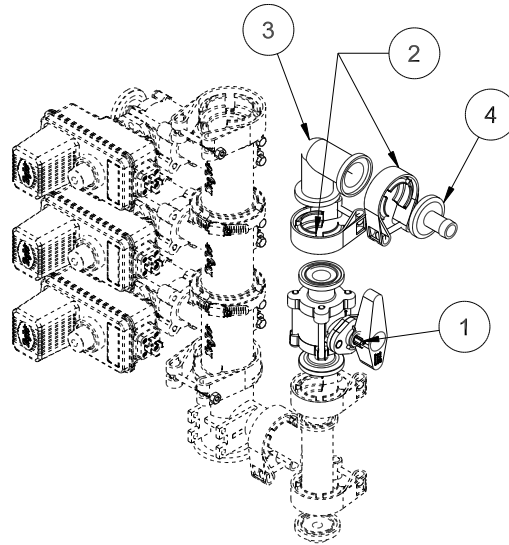

REF#	PART#	DESCRIPTION	QUANTITY
1	15-738	Flanged Ball Valve	1
2	15-740	50 Series Clamp	2
3	15-736	#50 Elbow Coupling	1
4	15-749	Hose Barb	1

INSTALLATION INSTRUCTIONS

Some machines are shipped with the flanged ball valve already installed. If your machine has the ball valve on the tee, remove cap from ball valve and skip to step 3.

1. Between the boom control valves and the fuel tank you will find a tee fitting with a black cap on top of it. Remove the clamp and the cap.
2. Install the 15-738 ball valve (Ref 1) onto the top of the tee using the clamp and o-ring you removed in step 1. The Handle can be positioned so it clears the other hoses by rotating it before the clamp is tightened. Tighten clamp when ball valve is in the position you wanted.
3. Install the 15-736 Elbow (Ref 3) on top of the ball valve pointing to the back of the machine and secure with 15-740 clamp (Ref 2). Tighten.
4. Install the 15-749 flanged hose barb (Ref 4) on to the open end of the elbow with a 15-740 clamp (Ref 2). Tighten.
5. Route the $\frac{3}{4}$ " hose from the hose barb you just installed to the hose barb on the hose reel. Secure with an 18-40 hose clamp. Secure hose to machine with 22-075 nylon ties.
6. There will be parts left over that you will not need.

15-965 FOAM MARKER DRAWING

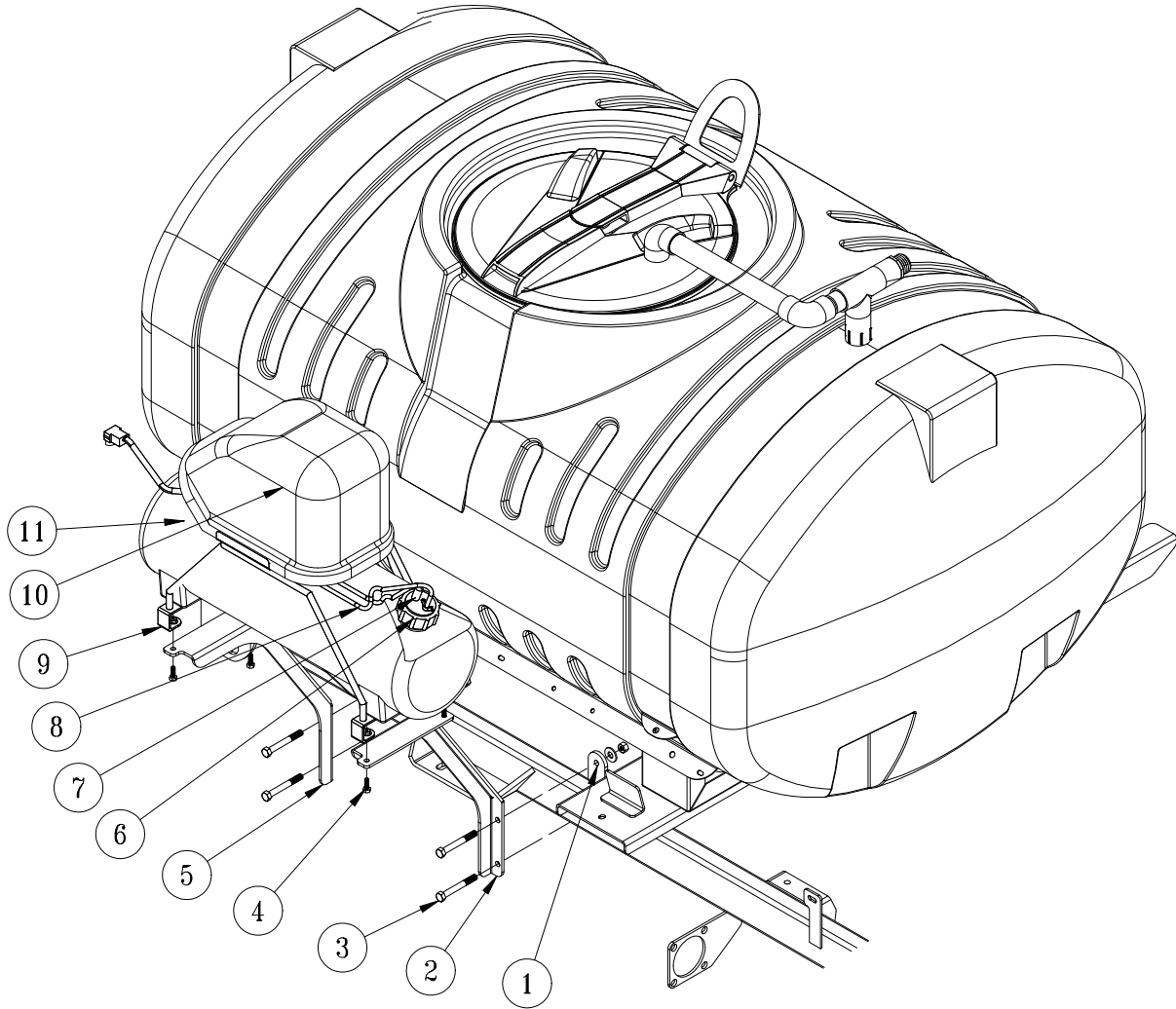

REF#	PART#	DESCRIPTION	QUANTITY
1	20-799	Backing Plate	2
2	20-791	Front Foamer Mount	1
3	HB-38-16-300	Hex Bolt, $\frac{3}{8}$ - 16 x 3	4
	HNTL-38-16	Nylon Lock Nut, $\frac{3}{8}$ - 16	4
	HW-38	Flat Washer, $\frac{3}{8}$	4
4	HB-14-20-075	Hex Bolt, $\frac{1}{4}$ - 20 x $\frac{3}{4}$	4
	HNFL-14-20	Flange Whiz-loc Nut, $\frac{1}{4}$ - 20	4
5	20-790	Rear Foamer Mount	1
6	14-284-02	Cap Assembly	1
7		Clear Tube	1
8		Blue Tube	1
9	14-291-04	Tank Bracket	2
10	14-291-03	Compressor Only	1
	14-291-01	Black Cover	1
11	14-291-02	Foamer Tank	1
6-11	14-291	Foamer (includes parts 6-11)	1

15-965 FOAM MARKER CONTROL PANEL

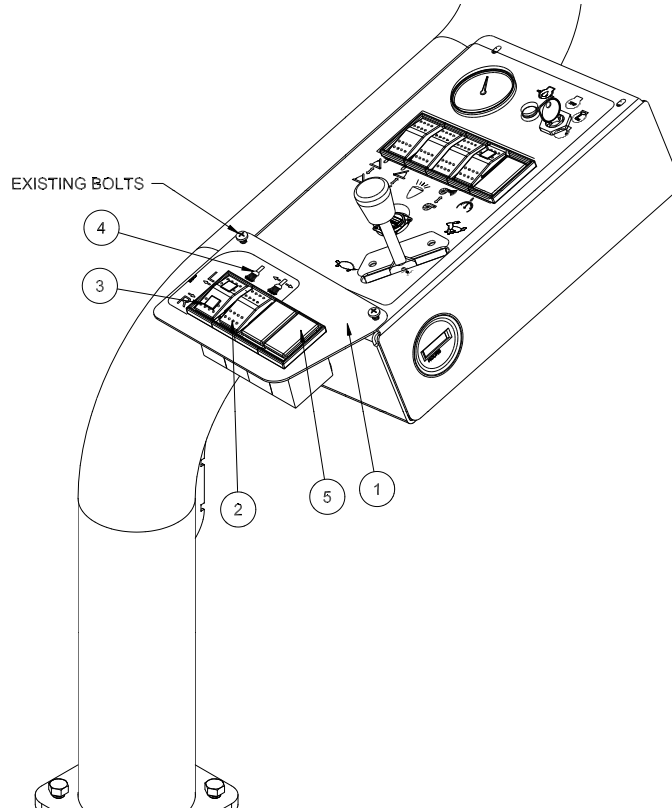

REF#	PART#	DESCRIPTION	QUANTITY
1	10-739	Switch Mount Plate	1
	15-725	Panel Mount End	2
2	15-782	Switch, Unlit	1
	15-727	Rocker, No Light	1
3	15-918	Switch, 2 Red LED	1
	15-917	Rocker, 2 Red Lenses	1
4	30-374	Decal, Foamer	1

Safety: Before working on machine: stop engine, set park brake, remove key from ignition and block wheels. Disconnect negative (-) battery terminal.

1. Place decal(Ref 4) on Switch mount plate. Place panel mount ends in mount plate.
2. Mount switches(Ref 2 & 3) to switch mount plate(Ref 1) as shown above. Mount the switch mount plate(Ref 1) on the side control panel using existing bolts.

Tank Mount Drawing

3. Position the Front Foamer Mount(Ref 2) and one Backing Plate on the right hand side of the mainframe ahead of the rear axle, secure using two $\frac{3}{8}$ x 3 bolts, flat washers and lock nuts. Repeat with the Rear Foamer Mount(Ref 5). *Leave loose enough to reposition when mounting the Foamer(Refs 6-11).*
4. Place Foamer unit(Refs 6-11) onto the Mounts. Using the $\frac{1}{4}$ x $\frac{3}{4}$ Bolts and $\frac{1}{4}$ Flange Lock Nuts fasten Foamer to Mounts. Tighten hardware.
5. Tighten hardware securing Foamer Mounts to the mainframe.

FOAMER NOZZLE MOUNT

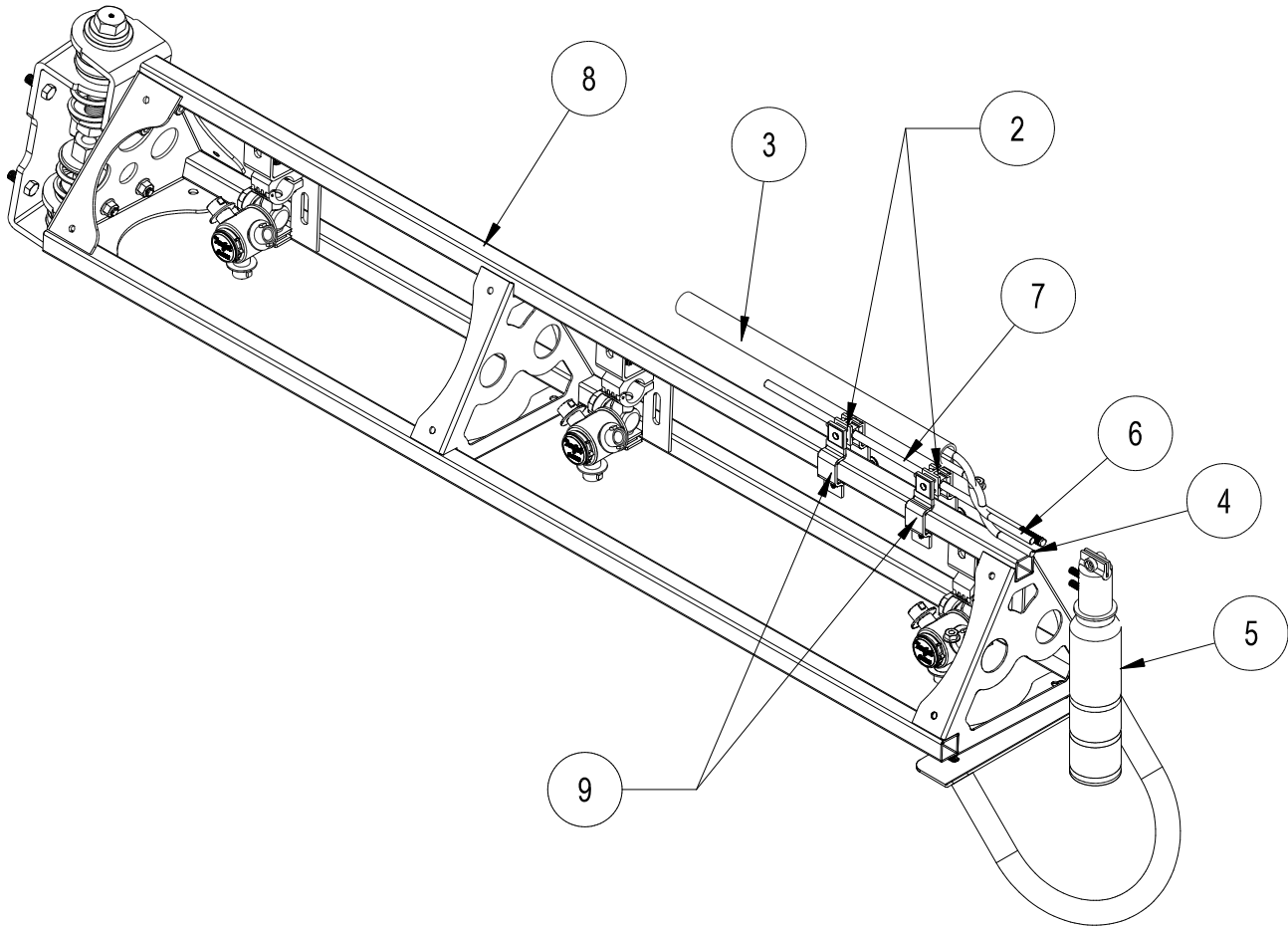

REF#	PART#	DESCRIPTION	QUANTITY
2	16-987	Foam Nozzle Mounting Kit	1 per boom
3	15-507	Foamer Tubing	1
4		Clear Tubing	
5	15-511	Foam Nozzle	2
6		Blue Tubing	
7	15-510-01	Nozzle Mounting Rod	2
8		Boom	
9	16-795	Square Clamp	4

INSTRUCTIONS

1. Slide hose clamp onto drop tube of foam nozzle and attach restricter bell.
2. Place splined end of Nozzle mounting rod (Ref 7) into top of foam nozzle (Ref 5). Tighten screw.
3. Slide two foam nozzle mounts (Ref 2) onto the rod. Place square clamps (Ref 9) on foam nozzle mounts and mount the square clamps to the boom (Ref 8). Adjust foam nozzle mounts and clamps so nozzle assembly will clear end of boom. Tighten foam nozzle mounts and square clamps to prevent side to side movement. Do the same to the other side.
4. Being careful not to cut the tubing (Ref 3), cut the oversleeve back approximately 2" (5 cm) to expose blue (Ref 6) and clear tubing (Ref 4).
5. Remove blue wing nut from top connector of foam nozzle and slide it on the blue tube with the threads facing toward end of tube. Slide blue tube all the way over the top of the small tube on foam nozzle. Slide wing nut back to the threads and hand tighten. Follow the same steps for the clear tube and tube nut.
6. Route the tubing along underside of main frame using tie downs as necessary.
7. Install opposite ends of air-liquid tubes to compressor, again cutting back the oversleeve approximately 2" (5 cm) and inserting blue and clear tubes for the left boom section into the tubing connectors (Ref A) on the right side of compressor as far as possible.
8. Follow the same steps for the right boom tubing. Notice the right boom is inserted into left side of compressor. To release tubing from compressor, hold black ring around tubing, and pull tube out.
9. Hose's must be routed on bottom of the boom square tubing.
10. Install hose guard using 2 drill screws (you may want to drill a $\frac{3}{16}$ pilot hole first).
11. Place another hose guard against first and install in same manner.
12. Repeat process for other boom side.
13. Connect small plastic electrical plug under compressor to electrical extension cable.
14. Cut cable and strip casing, allowing enough length to connect to fuse block.
15. Strip and connect slide on connectors to each wire and use the heat shrink.
16. Connect black negative (-) wire to the ground and connect red wire to the positive (+).
17. Insert 10 amp fuse into slot which red wire was attached to.

14-291 FOAMER REPLACEMENT PARTS

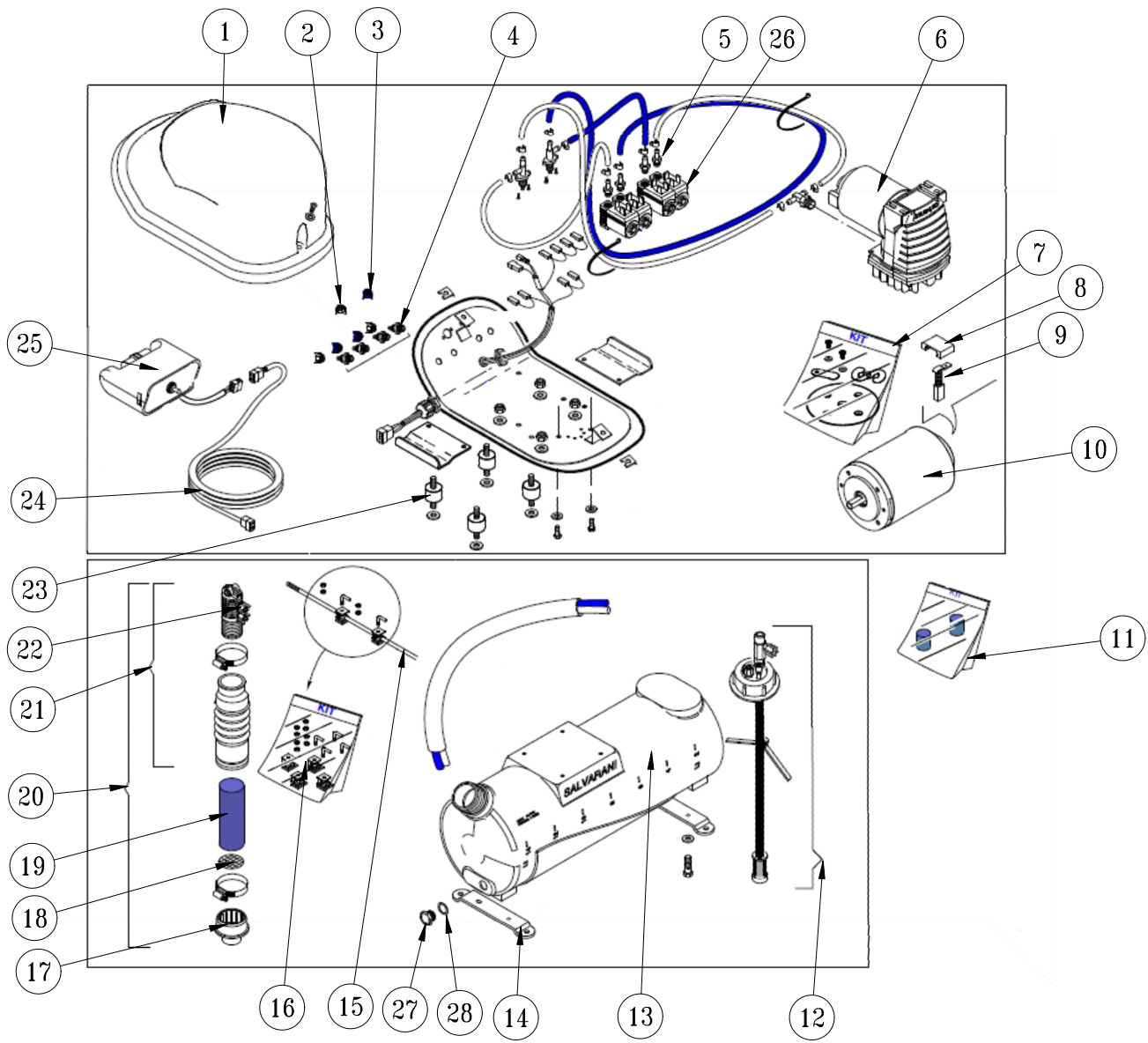

Accessories

14-291 FOAMER REPLACEMENT PARTS

REF#	PART#	DESCRIPTION	QUANTITY
1	14-291-01	Black Cover	1
2	14-291-08	White Fly Nut	1
3	14-291-09	Blue Fly Nut	1
4	14-284-10	Tubing Connector	1
5	14-291-17	M6 Tubing Connector	1
6	14-536	Compressor Complete	1
7	14-291-11	Diaphragm Replacement Kit	1
8	15-505-08	Brush Retainer	1
9	15-505-06	Brush	1
10	15-505-07	12V Electric Motor	1
11	15-511-02	Foam Sponge	1
12	14-284-02	Cap Assembly	1
13	14-291-02	Foamer Tank	1
14	14-291-04	Tank Brackets	2
15	15-510-01	Nozzle Mounting Rod	2
16	16-987	Foam Nozzle Mounting Kit	1
17	14-284-09	Foam Nozzle Reducer	2
18	15-511-09	Stainless Steel Screen	2
19	15-511-08	Long Foam Sponge	2
20	15-511	Foam Nozzle	2
21	15-511-07	Foam Nozzle Assembly	1
22	15-511-01	Foam Nozzle Sub Assembly	1
23	14-291-15	Shock Absorber	4
24	14-284-05	Extension Wire	1
25	14-291-05	Switch Box	1
	15-506-02	Switch	1
26	14-284-11	Solenoid Valve	4
27	14-291-19	Drain Plug	1
28	14-291-18	Drain Plug Seal	1

FOAM MARKER WIRING

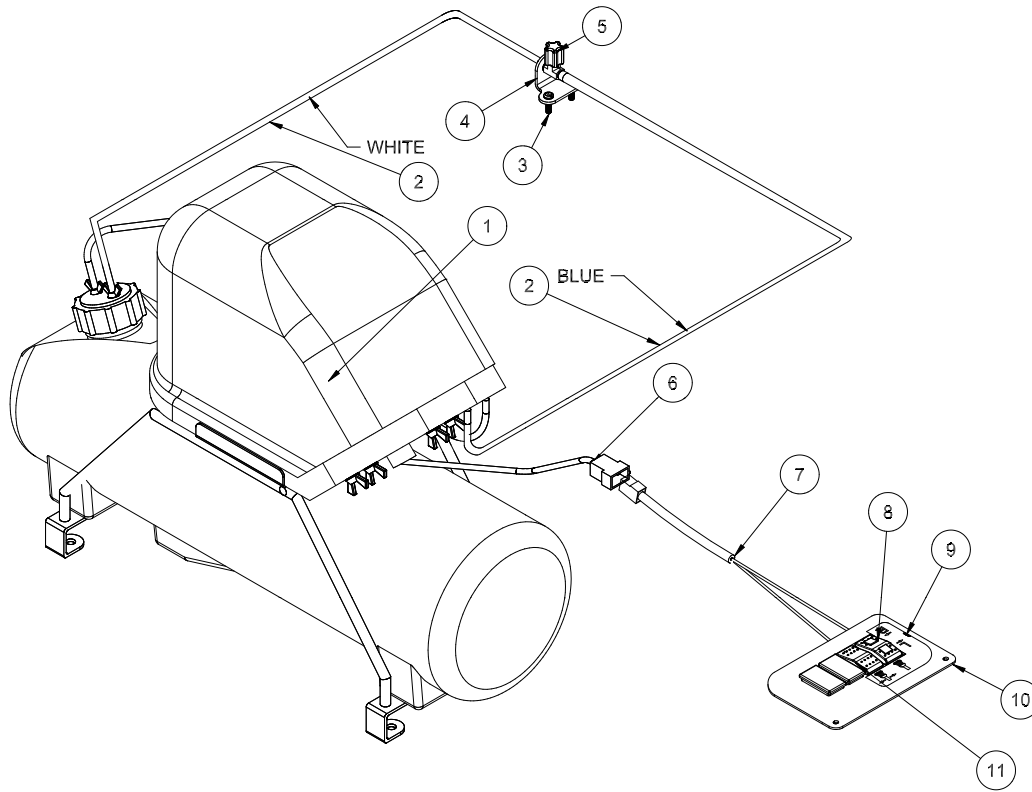

REF#	PART#	DESCRIPTION	QUANTITY
1	14-291-03	Compressor	1
2	15-507	Tubing -Blue and white	1
3	HSM-10-32-075	Machine Screw, #10-32 x 3/4	2
	HNFL-10-32	Flange Whiz-loc Nut, #10-32	2
4	20-769	Mount Bracket	1
5	14-699	Malle Coupler	1
	14-291-09	Blue FLY Nut	1
	14-702	Red Washer	1
6	15-504-04	Foam Marker Wiring Harness	1
7	32-574	Foamer Wire Harness	1
8	15-918	Switch, 2 Red LED	1
	15-917	Rocker, 2 Red Lenses	1
9	30-374	Decal, Foamer	1
10	10-739	Switch Mount Plate	1
11	15-782	Switch, Unlit	1
	15-727	Rocker, No Light	1

INSTALLATION

1. Connect the compressor wire harness (Ref 6) to the switches using the wire harness (Ref 7).
2. Use dielectric grease on all electrical connections. Route the wire harness to the battery and out of the way of any heat or moving parts. Use nylon ties as needed. Connect the wire harness to the battery. Red to positive(+), black to negative(-).

20-815 WATER METER KIT (GALLONS)

20-816 WATER METER KIT (LITERS)

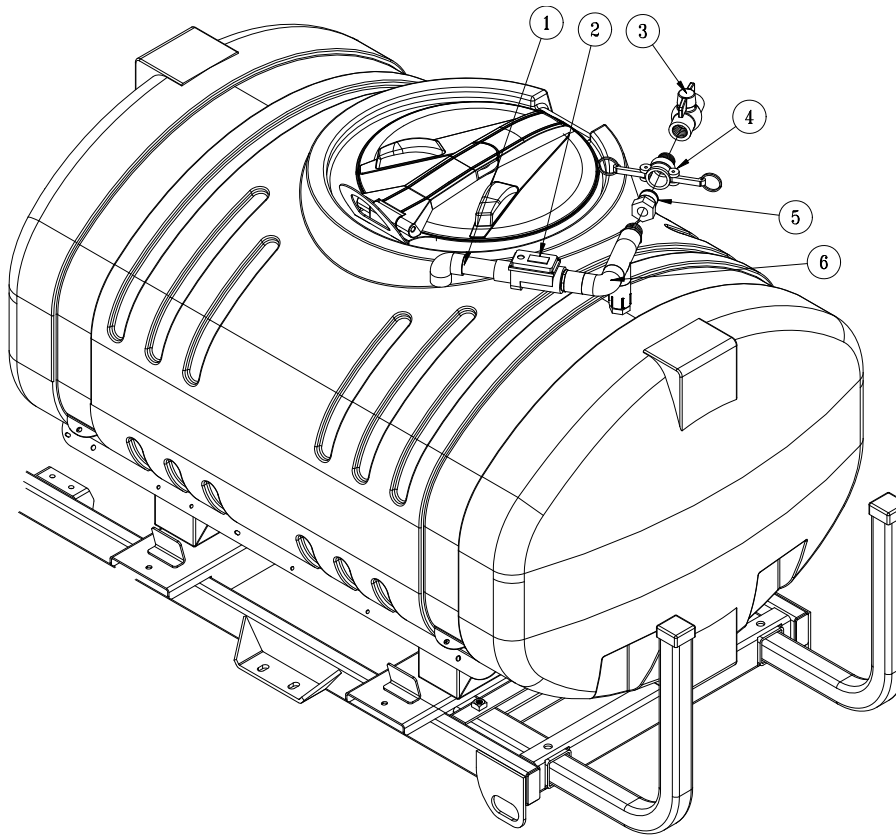

REF #	PART #	DESCRIPTION	QUANTITY
1	20-814	Filler Outlet	1
2	14-804	Water Meter	1
	14-527	Water Meter (Liters)	1
3	18-448	1" Ball Valve (already on machine)	1
4	16-962	1" Quick Coupler (already on machine)	1
5	16-961	1" Adapter Quick Coupler (already on machine)	1
6	20-813	Filler Inlet	1

1. Thoroughly flush the service line upstream of the meter to remove dirt and debris.
2. The DLJ Meter is for use **only** with **COLD WATER** up to 122°F (50°C)
3. Slowly open any upstream valves to prevent damage to the meter.

Gallons to Cubic feet Conversion :

Multiply gallons reading by 0.1337 to get cubic feet.

There are 7.48052 gallon per cubic foot.

15-968 20 GALLON RINSE TANK PARTS LIST

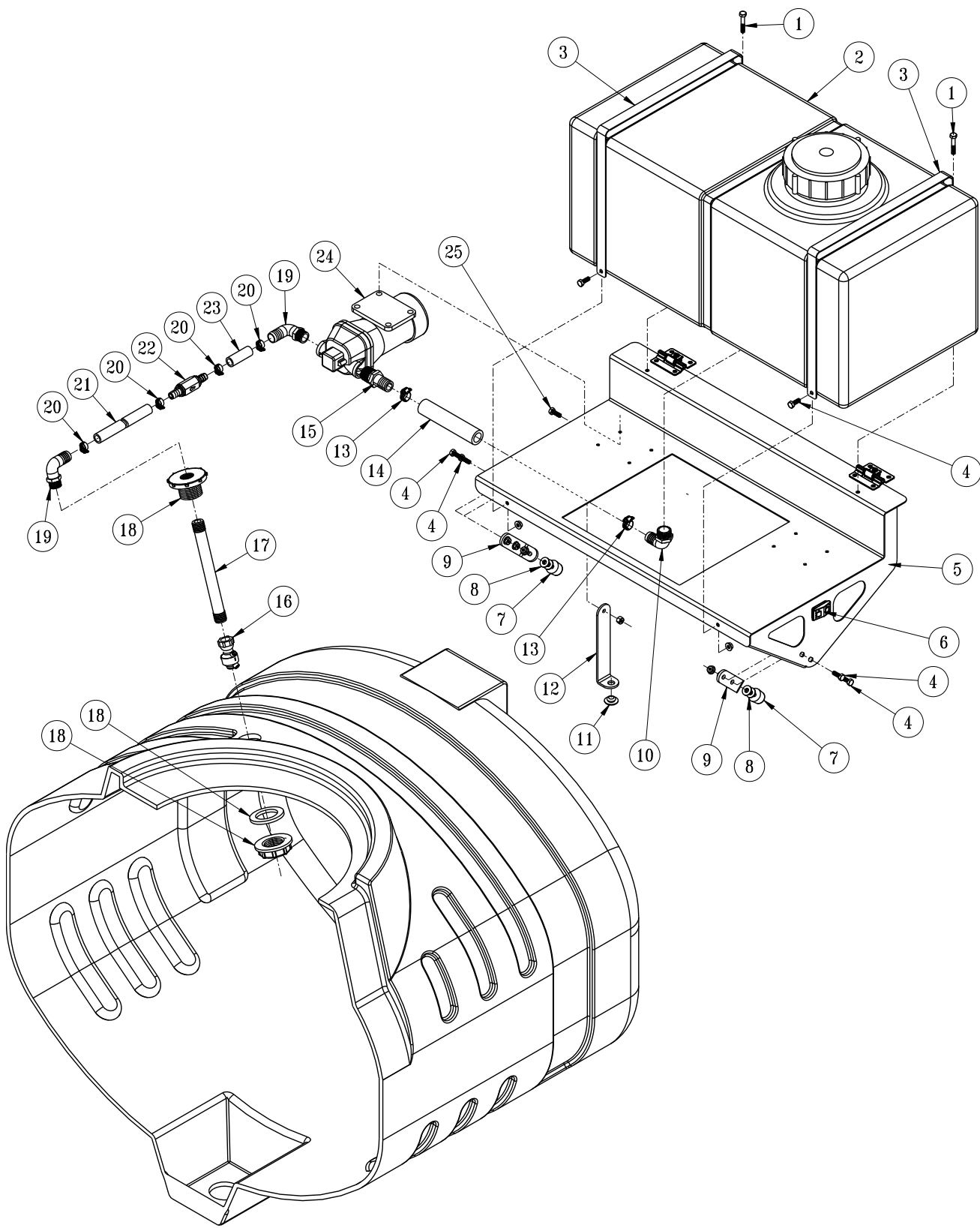

Accessories

15-968 20 GALLON RINSE TANK PARTS LIST

REF#	PART#	DESCRIPTION	QUANTITY
1	HB-14-20-150	Hex Bolt, $\frac{1}{4}$ - 20 x $1\frac{1}{2}$	2
	HNFL-14-20	Flange Lock Nut, $\frac{1}{4}$ - 20	2
2	20-797	20 Gallon Tank	1
3	20-800	Tank Strap	2
4	HB-14-20-075	Hex Bolt, $\frac{1}{4}$ - 20 x $\frac{3}{4}$	6
	HNFL-14-20	Flange Lock Nut, $\frac{1}{4}$ - 20	6
5	20-792	Rinse Tank Mount	1
6	15-726	Lighted Rocker Switch	1
	15-917	Red Rocker	1
7	15-013	Rubber Bumper	2
	HNFL-14-20	Flange Lock Nut, $\frac{1}{4}$ - 20	2
8	HW-14	Flat Washer, $\frac{1}{4}$	4
9	20-801	Bumper Mount	2
10	16-153	Elbow	1
11	42-116	Rubber Pad	1
12	15-933	Prop Strap	1
13	18-040	Hose Clamp, HS12	2
14	9032-5.5	Black Hose, $\frac{3}{4}$	1
15	18-489	Connector, $\frac{1}{2}$ NPT x $\frac{3}{4}$ Barb	1
16	30-246	Rinse Nozzle	1
17	30-247	PVC Nipple	1
18	33-495	Bulkhead Fitting	1
19	16-186	Elbow, $\frac{1}{2}$ NPT x $\frac{3}{4}$ Barb	2
20	18-077	Hose Clamp, HS10	3
21	9050-51	Nylon Clear Tubing, $\frac{1}{2}$	1
22	18-497	Check Valve	1
23	9050-2	Nylon Clear Tubing, $\frac{1}{2}$	1
24	20-798	Pump, 4 GPM	1
25	HB-14-20-075	Hex Bolt, $\frac{1}{4}$ - 20 x $\frac{3}{4}$	1
	HNTL-14-20	Nylon Lock Nut, $\frac{1}{4}$ - 20	1

⚠ WARNING

This tank is for fresh clear water ONLY. Do not put chemicals in this tank.

30-006 FRESH WATER WASH TANK -REAR MOUNT

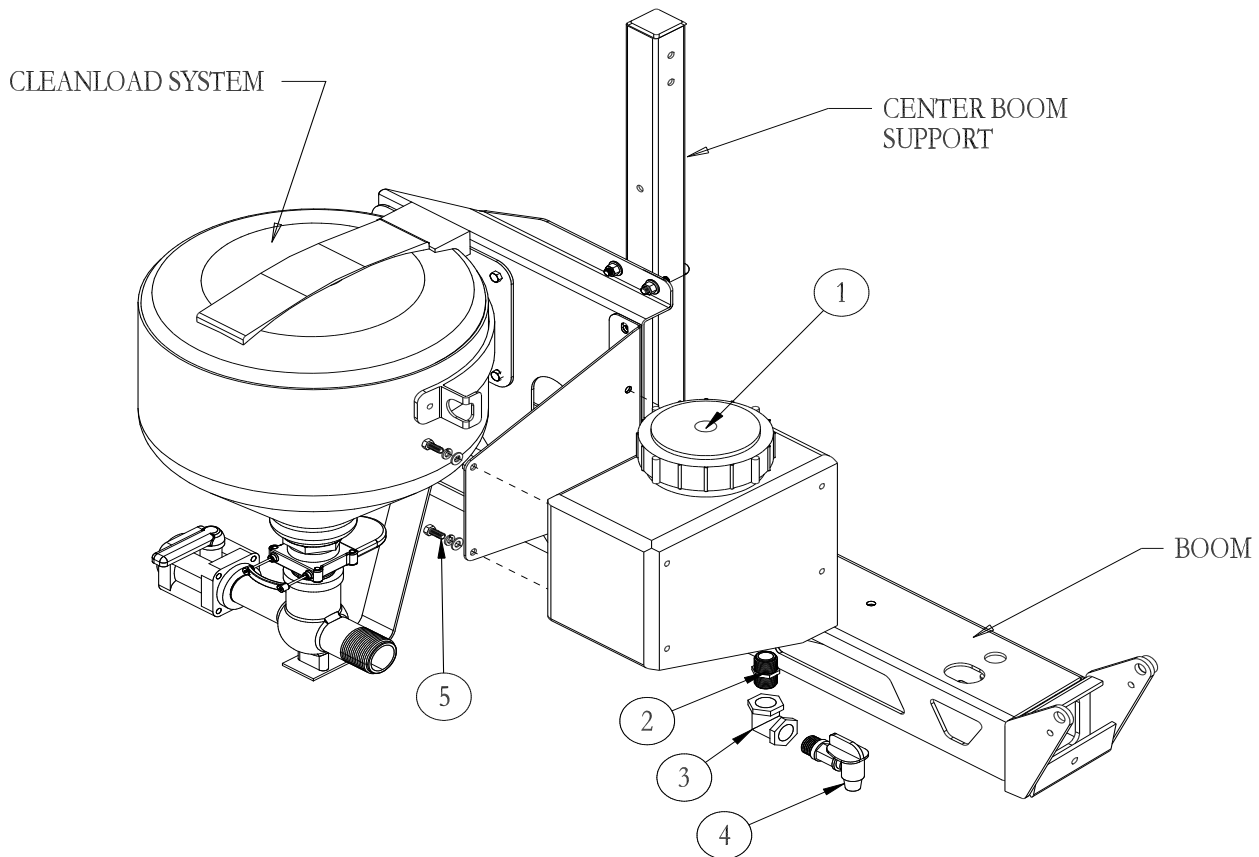

REF#	PART#	DESCRIPTION	QUANTITY
1	10-234	Wash Tank	1
2	16-158	Close Nipple	1
3	16-151	Elbow	1
4	16-960	Spigot	1
5	HB-516-18-075	Hex Bolt, $\frac{5}{16}$ - 18 x $\frac{3}{4}$	4
	HWL-516	Lockwasher, $\frac{5}{16}$	4
	HW-516	Flat Washer, $\frac{5}{16}$	4

1. Fresh Water Wash Tank mounts on the rear of all the machines.
2. The Bracket is already attached to the Super Boom center boom post.
3. Install the nipple (Ref 2), elbow (Ref 3) and spigot (Ref 4) into the bottom of wash tank (Ref 1). Use thread tape on all threads.
4. Mount the tank onto the mount bracket using four $\frac{5}{16}$ x $\frac{3}{4}$ bolts, washers and lockwashers. Tighten.
5. Rinse tank with clear water and check for leaks around fittings.

⚠ WARNING

This tank is for fresh clear water ONLY. Do not put chemicals in this tank.

17-506 FRESH WATER WASH TANK - FRONT MOUNT

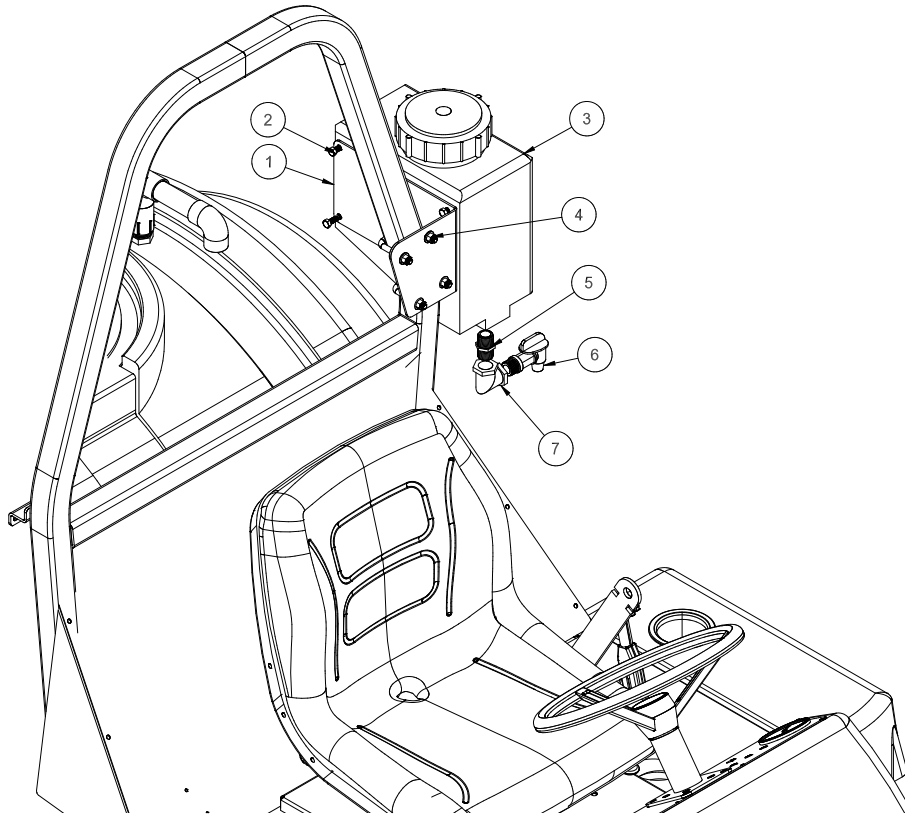

REF#	PART#	DESCRIPTION	QUANTITY
1	10-652	Mount Plate	1
2	HB-516-18-075	Bolt $\frac{5}{16}$ - 18 x $\frac{3}{4}$	4
	HWL-516	Lockwasher $\frac{5}{16}$	4
	HW-516	Washer $\frac{5}{16}$	4
3	10-234	Wash Tank	1
4	17-537	Square U-Bolt	2
5	16-158	Close Nipple	1
6	16-151	Elbow	1
7	16-960	Spigot	1

1. Fresh Water Wash Tank mounts on the left side ROPs.
2. Mount the wash tank (Ref 3) onto the mount bracket (Ref 1) using four $\frac{5}{16}$ x $\frac{3}{4}$ bolts, washers and lockwashers (Ref 2). Tighten.
3. Install the nipple (Ref 5), elbow (Ref 6) and spigot (Ref 7) into the bottom of wash tank (Ref 1). Use thread tape on all threads.
4. Mount the tank assembly to the left side ROPs with u-bolts (Ref 4). Tighten.
5. Rinse tank with clear water and check for leaks around fittings.

⚠ WARNING

This tank is for fresh clear water ONLY. Do not put chemicals in this tank.

15-619 CHEMICAL CLEAN-LOAD SAFE FILL SYSTEM

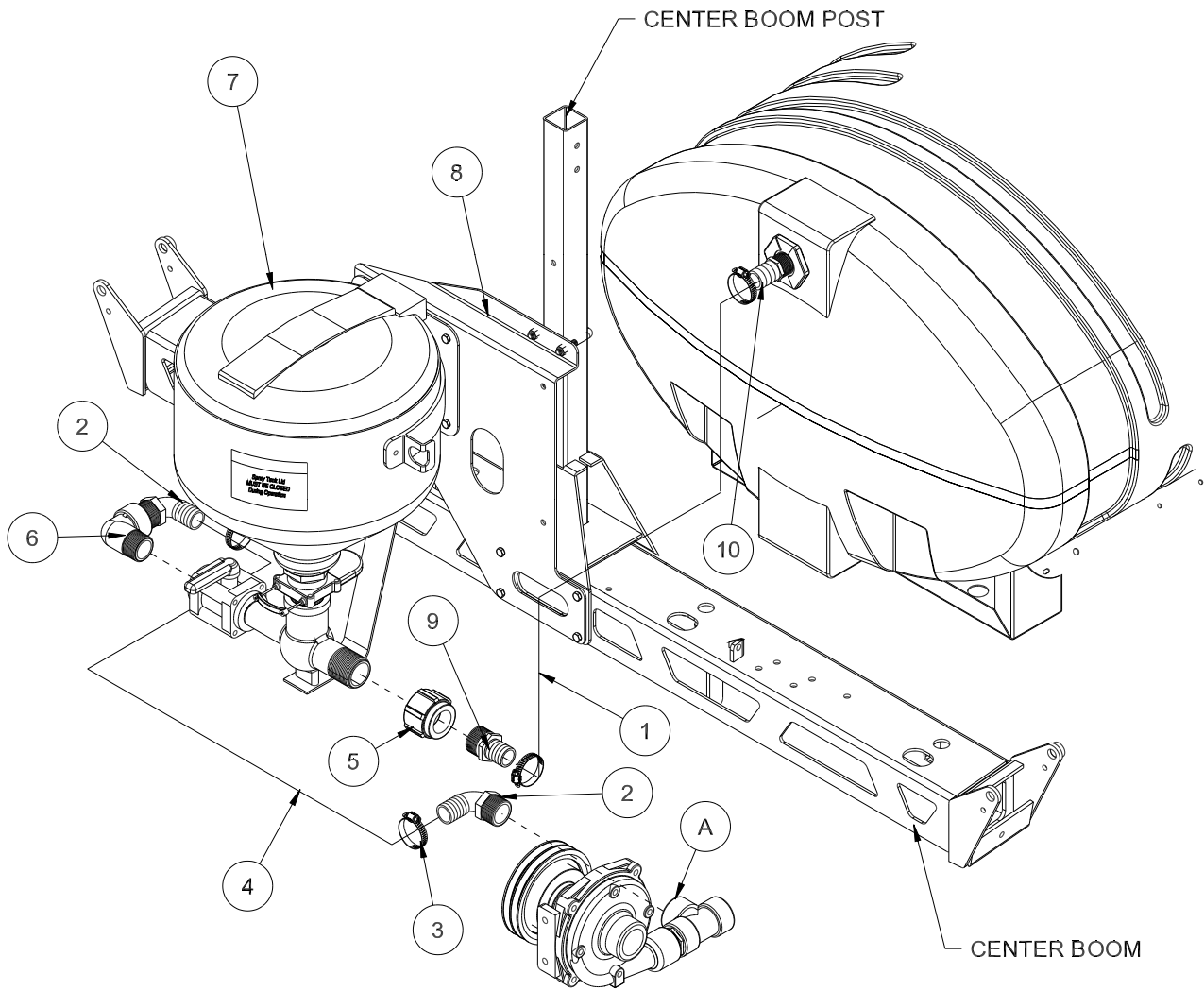

REF#	PART #	DESCRIPTION	QUANTITY
1	8897-46	1 1/4" Discharge Hose 46"	1
2	16-156	90° Hose Barb	2
3	18-116	Hose Clamp	4
4	8897-113	1 1/4" Discharge Hose 113"	1
5	18-391	Coupling	1
6	16-972	Street Elbow	1
7	15-620	Cleanload Assembly	1
	25-389	Decal, Tank Lid	1
	HBFL-516-18-075	Flange Bolt, 5/16 - 18 x 3/4	4
	HNFL-516-18	Flange Lock Nut, 5/16 - 18	4
8	17-635	Clean Load Mount (comes with boom)	1
9	16-161	Straight Fitting	1
10	16-159	Fitting	1

15-619 CHEMICAL CLEAN-LOAD INSTALLATION INSTRUCTIONS

1. Make sure sprayer tank is empty and flush all chemical residue from sprayer. Always wear protective clothing, goggles and gloves.
2. Remove plug from tee on spray pump (Ref A).
3. Install one of the 90° fittings (Ref 2), should point to the back of the machine.
4. Install 113" of 1 1/4" discharge hose (Ref 4) onto the elbow on the pump that points back and tighten hose clamp (Ref 3).
5. Route the 113" hose to the back of the sprayer so it connects over the top of the left boom support tube.
6. Mixer Mount (Ref 8) is already installed on boom center post.
7. Mount Cleanload Assembly (Ref 5) onto mixer mount using 5/16 x 3/4 flange bolts and flange nuts. Tighten.
8. Install 18-391 reducer coupling (Ref 4) onto outlet side. Then a 16-161 fitting (Ref 9) into the coupling. Tighten fittings so that the elbow in the valve is pointing up and forward.
9. Remove the plug from the top back of the spray tank and install a 16-159 hose barb (Ref 10) and tighten.
10. Now the 46" hose (Ref 1) can be installed from the tank to the outlet fitting. Tighten with hose clamps.
11. The hose from the spray pump can be connected to the inlet fitting and tightened with hose clamps.
12. Make sure all hardware, fittings and clamps are tight. Add about 25 gallons of water to the spray tank. Start sprayer and circulate water through system to check for leaks.
13. Be sure to read start up, loading and shutdown instructions for Cleanload Assembly before using with chemicals. When working with chemicals **Always** wear protective clothing, goggles and gloves.

SPRAY TANK LID MUST BE CLOSED WHEN USING CLEANLOAD.

TROUBLE SHOOTING

Symptom	Corrective Action
Low education rate	Check pump pressure and flow. Cleanload Eductor performance is based on flow and pressure to the system. Note requirements for high education rates. Increase outlet hose size back to tank.
Plugged or clogged bottle rinse nozzle	Disassemble rotary portion of nozzle from lower valve assembly and back flush until nozzle ports are clear of debris.
Plugged or clogged tank rinse nozzle	Disassemble rotary portion of nozzle from NPT hose barb and back flush until nozzle ports are clear of debris. Remove screen and flush with water to clear away foreign material.
Fitting leaks	Check for cracks in fitting. Replace fitting if necessary. Disassemble and add more joint seal in compound if leak occurs on threads.

15-620 CHEMICAL CLEAN-LOAD® PARTS DRAWING

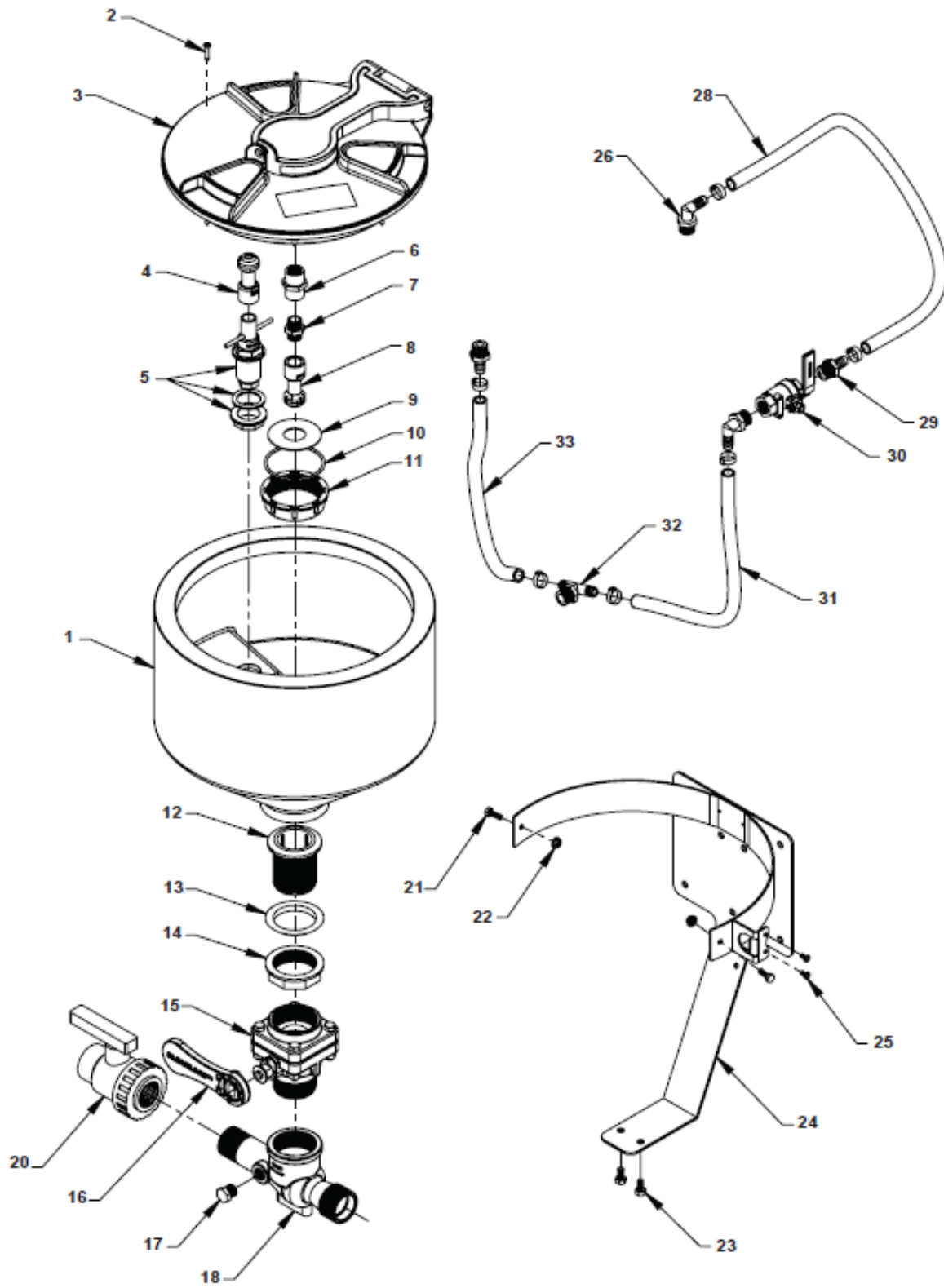

Accessories

15-620 CHEMICAL CLEAN-LOAD® PARTS LIST

REF#	PART#	DESCRIPTION	QUANTITY
1	15-620-21	Tank	1
2		Screw, #6 x 1"	8
3	15-620-02	Tank Lid	1
4	15-620-22	ProClean Container Nozzle	1
5	15-620-23	ProClean Push Valve Assembly	1
	15-620-19	Tank Rinse	1
	15-620-20	Gasket, 1"	1
6		1/2 x 1/2 FNPT Coupler	1
7		1/2 x 1/2 Thread Nipple	1
8		ProClean Tank Wash Nozzle	1
9		Splash Retainer	1
10		O-ring Breather	1
11		Nut, Breather	1
12	15-620-18	Drain Head, 2"	1
13	15-620-17	Gasket 2", Tapered	1
14	15-620-16	Locking Ring, 2"	1
15	15-620-12	Ball Valve	1
	15-620-15	Gasket 2" BSP	1
16	15-620-13	Handle, Clean-load	1
17		1/2 MNPT PP Hex Plug	1
18	15-620-04	Clean-load Eductor	1
20	15-620-14	Ball Valve, 1 1/4 Single Union	1
21		Screw	2
22		Flange Nut	2
23		Hex Head Screw	2
24	15-620-01	Frame, Back Mount	1
25		Phillips Head Screw	2
26	15-620-11	Elbow 1/2"	2
28	15-620-08	Hose, Tank Rinse, 1/2" EPDM	1
29	15-620-09	HB, 1/2 MNPT x 1/2 HB	2
30	15-620-10	Valve, SS Tank Rinse	1
31	15-620-06	Hose, Valve Feeder, 1/2" EPDM	1
32	15-620-05	HB Tee, 1/2 MNPT to 1/2 HB	1
33	15-620-07	Hose, Bottle Rinse, 1/2" EPDM	1

OPERATING INSTRUCTION

STARTUP

1. All Clean-load valves must be closed prior to starting: inlet ball valve, knife valve and hopper rinse ball valve.
2. Open lid to check for foreign objects which may hinder performance or contaminate the system.
3. Close and lock lid by turning cover clockwise.
4. Divert pump flow to Clean-load inlet line. A pressure of 30 PSI minimum and 150 PSI maximum must be used. Highest pressures increase eduction rate and available wand suction.
5. Turn inlet ball valve on (yellow handle).
6. Open knife valve, located on the bottom of hopper, by pushing handle in (red handle).
7. Unlock and open lid slowly by turning cover counterclockwise.

LOADING LIQUID OR POWDERED CHEMICAL INTO HOPPER

8. Pour required amount of chemical into hopper. Avoid splashing liquids or powdered chemicals outside of hopper.
9. Rinse empty chemical containers if applicable. Place container opening over container rinse valve and press down. This will activate the rinse valve and rinse container.
10. Rinse Clean-load hopper. Close and lock lid by turning cover clockwise. Release the safety locking band on the hopper rinse ball valve and turn on for 20 seconds. Close ball valve and return locking band to locked position.
11. Open lid and inspect for chemical residue. Repeat step 10 as necessary.
12. Close knife valve by pulling red handle out towards you. Turn inlet (yellow handle) off.

LOADING LIQUID AND/OR POWDERED CHEMICAL WITH SUCTION LANCE

Note: Lance suction is dependent upon eductor pressure and flow. For best results, use highest pressure available up to 150 PSI maximum.

8. Insert lance body with o-ring into eductor until the o-ring is sealed.
9. Use the free end of the lance to pierce bag or container to vacuum powdered or liquid chemical.
10. Rinse lance. Place lance end into a clean container of water to rinse lance assembly.
11. Remove lance body from eductor and drain any remaining fluid into hopper.
12. Close knife valve (red handle). Turn inlet valve (yellow handle) off.

SHUTDOWN

1. Ensure that:
 - All valves are closed. Be sure to close knife valve first. (Close by pulling red handle out towards you.)
 - Chemical residue has been cleaned.
 - Hopper lid is closed and locked by turning cover clockwise.
2. Divert pump flow back to normal operation.

DECAL LOCATION

⚠ WARNING

If Safety Decals** have been damaged, removed, become illegible or parts replaced without decals, new decals must be applied. New decals are available from your authorized distributor.

This is a list of decals located on the Spray Star 1200. Part number, description and location will help in re-ordering decals.

A	20-705	Decal, Tank Volume
B	20-707	Decal, Rear Tank Volume
C**	15-463	Decal, Spray Pump
D	20-706	Decal, Spray Star 1200
E**	10-657	Decal, Control Panel
F**	51-184	Decal, Park Brake
G**	15-719	Decal, Speed Control
H**	25-298	Decal, Warning Hot
I**	25-307	Decal, Gas
J*	25-286	Decal, Pinch Point
K	25-356	Decal, Tire Pressure
L	25-373	Decal, Smithco
M	25-381	Decal, 96 dBA
N	27-077	Decal, Smithco
O**	27-093	Decal, Hydraulic Oil
P**	25-277	Decal, Battery

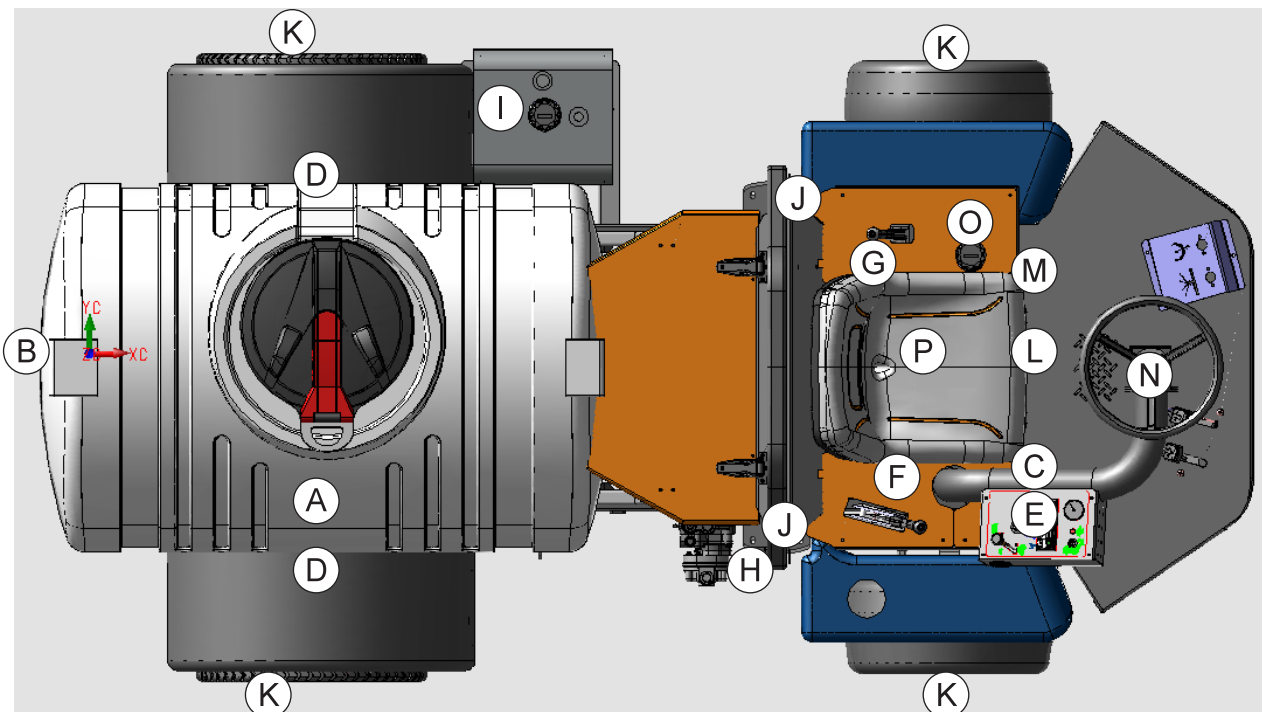

Accessories

QUICK REFERENCE REPLACEMENT PARTS

REPLACEMENT FILTERS

23-031	Hydraulic Oil Filter	
76-487	Engine Oil Filter	Briggs # 842921
76-395-01	Air Cleaner Cartridge	Briggs # 841497
76-395-02	Safety Filter Cartridge	Briggs # 821136
13-488	Key Switch	
8-709	Key Set	
50-403	Fuel Filter	

REPLACEMENT BELTS

16-869	Spray Pump Belt
--------	-----------------

SEAL KITS

15-301	Power Steering Orbital Motor
15-301-01	Seal Kit
15-839	Hydraulic Cylinder
15-839-01	Seal Kit
76-238	Wheel Motors
14-080	Seal Kit
76-638	Hydrostatic Pump
77-239-23	Seal Kit
76-197	Gear Pump
76-197-08	Seal Kit

FLUIDS

Engine Oil	SAE 10W-40 API Service SJ or higher Motor Oil
Hydraulic Fluid	SAE 10W-40 API Service SJ or higher Motor Oil

OTHER PARTS

16-953	Hinged Cover On Tank with Gasket	
16-953-01	Gasket For Cover	
16-169	Strainer Basket	
15-818	#75 Fitting Oring	
15-817	#50 Fitting Oring	
	Spark Plugs	Champion type RC12YC (Gap 0.040 inch (1.02mm))

The Smithco Commercial Products Two-Year Limited Warranty

Smithco, Inc. (Smithco) warrants your 2016 or newer Smithco Commercial Product ("Product") purchased after October 1, 2016 to be free from defects in materials or workmanship for the period of time listed below. Where a warrantable condition exists, Smithco will repair the Product at no cost to you including diagnosis, labor (at the Smithco standard labor rate, subject to the Smithco flat rate schedule), and parts.

Warranty Duration is:

- (1) Two years, 1500 operational hours* from the date of delivery to the original purchaser or Five years from the date of original manufacturer of the product, whichever occurs first. (*Products equipped with hour meter).
- (2) Products used in rental situations are covered for 90 days from date of delivery to original user/renter.

Owner Responsibilities:

As the Product owner, you are responsible for required maintenance and adjustments stated in your Owner's Manual. Failure to perform required maintenance and adjustments can be grounds for disallowing a warranty claim. **You are particularly responsible to train all present and future operators of this product on the safe operation of this product at your location.**

Instructions for Obtaining Warranty Service:

You are responsible for notifying the Authorized Smithco Products Distributor from whom you purchased the Product as soon as you believe a warrantable condition exists and not later than 30 days from discovery of the condition.

If you need help locating an Authorized Smithco Distributor, or if you have questions regarding your warranty rights or responsibilities, you may contact us at:

Smithco Product Support Department
200 West Poplar Ave.
Cameron, Wisconsin 54822
Telephone: 800-891-9435 E-Mail: ProductSupport@Smithco.com

Maintenance Parts:

Parts scheduled for replacement as required maintenance ("Maintenance Parts"), are warranted for the period of time up to the scheduled replacement time for that part.

Items/Conditions Not Covered:

Not all product failures or malfunctions that occur during the warranty period are defects in materials or workmanship. The items/conditions listed below are not covered by this warranty:



Product failures which result from the use of non-Smithco replacement parts, or from installation and use of add-on, modified, or unapproved accessories are not covered.



Product failures which result from failure to perform required maintenance and/or adjustments are not covered.



Product failures that result from operating the Product in an abusive, negligent or reckless manner are not covered.



This warranty does not apply to parts subject to consumption through use, unless found to be defective. Examples of parts which are consumed, or used up, during normal Product operation include, but are not limited to: blades, tines, teeth, scarifiers, rakes, plates, wear plates, castor wheels, tires, batteries, filters, belts, nozzles, etc.



This warranty does not apply to failures caused by outside influence. Items considered to be outside influence include, but are not limited to, weather, storage practices, contamination, use of unapproved coolants, lubricants, additives, or chemicals, etc.



This warranty does not apply to normal “wear and tear” items. Normal “Wear and Tear” includes, but is not limited to, damage to seats due to wear or abrasion, worn painted surfaces, scratched decals or windows, etc.



Smithco may require the return of failed parts or components in order to determine the validity of any warranty claim.



Smithco will not be obligated to replace components of other manufacturers if inspection by the original component manufacturer indicates that failure was due to normal wear and tear, expected consumption through use or improper care or service.

Other Legal Disclaimers:

The above remedy for product defects through repair or replacement by an authorized Smithco distributor or dealer is the purchaser’s sole remedy for any defect. This warranty gives you specific legal rights, and you may also have other rights which vary from state to state.

THERE ARE NO OTHER EXPRESS WARRANTIES OTHER THAN THOSE SET FORTH ABOVE. ALL IMPLIED WARRANTIES OF MERCHANTABILITY AND FITNESS FOR USE ARE LIMITED TO THE DURATION OF THE LIMITED WARRANTIES CONTAINED HEREIN.

Some states may not allow limitations on how long an implied warranty lasts, so the above limitation may not apply to you.

THE SMITHCO COMPANY IS NOT LIABLE FOR INDIRECT, INCIDENTAL OR CONSEQUENTIAL DAMAGES IN CONNECTION WITH THE USE OF THE PRODUCT, INCLUDING ANY COST OR EXPENSE OF PROVIDING A SUBSTITUTE PRODUCT OR SERVICE DURING PERIODS OF MALFUNCTION OR NON-USE.

Some states may not allow the exclusion of indirect, incidental or consequential damages, so the above exclusion may not apply to you.

Smithco neither assumes, nor authorizes any person to assume for it, any other liability in connection with the sale or use of this product.

