

Parts & Service

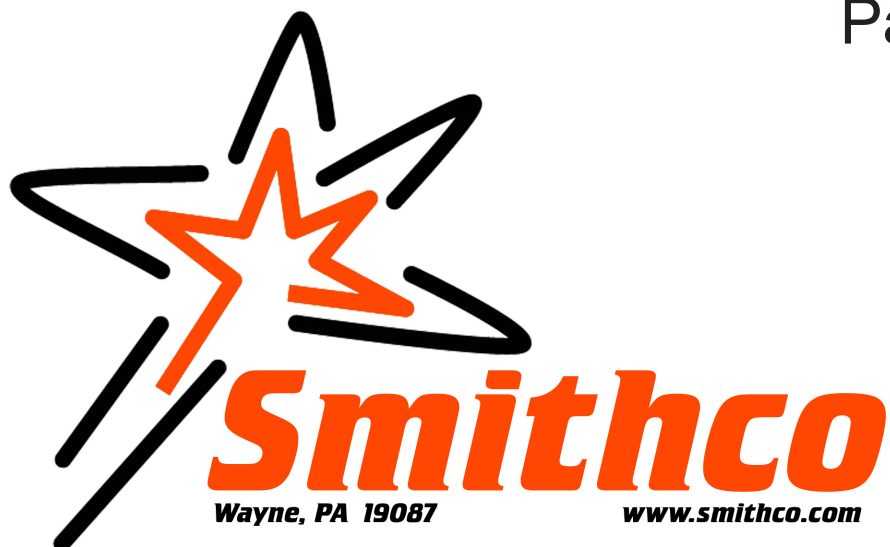

Sweep Star 48H
48-500-A
SN: GH5288

April 2020

Product Support: Hwy 55 & Poplar Ave; Cameron WI 54822
1-800-891-9435 productsupport@smithco.com

CONTENTS

Introduction

Introduction	1-3
Safe Practices	2
Specification	3
Optional Equipment	3

Service

Service	4-10
Maintenance	4-6
Service Chart	7
End User's Service Chart	8
Adjustments	9
Storage	9
Reel Height Adjustment	10

Diagrams

Diagrams	11-15
Wiring Diagram	12-13
Hydraulic Diagram High Lift	14-15

Parts

Parts	16-90
Smithco Engineered Roll Over Protection	16-17
Nose Cone	18-19
Steering	20-21
Front Fork	22-23
Foot Pedal Linkage	24-25
Seat and Console	26-27
Fuel and Oil Tank	28-29
Hopper Lift Cylinder	30-31
Reel Lift Cylinder	30-31
Tailgate Cylinder	30-31
Engine and Exhaust	32-35
Electric Clutch Driven Belt Drive and Muffler	36-37
Finger / Brush Reel	38-39
Rear Axle	40-41
Hopper and Tailgate	42-43
48-267 Hydrostatic Pump	44-45
48-267 Repair Instructions	46-54
48-266 Gear Pump	55
48-266 Repair Instructions	56-66
76-238 Rear Wheel Motor	67
76-238 Repair Instructions	68-89
48-258 3-Bank Hydraulic Valve	90

Accessories

Accessory	91
45-501 Hopper Dust Cover	91

Reference

Reference	93-94
Decal List	93
Quick Reference Replacement Parts	54
Warranty	Inside Back Cover

Thank you for purchasing a **Smithco** product.

Read this manual and all other manuals pertaining to the Sweep Star 48H carefully as they have safety, operating, assembly and maintenance instructions. Failure to do so could result in personal injury or equipment damage.

Keep manuals in a safe place after operator and maintenance personnel have read them. Right and left sides are from the operator's seat, facing forward.

 WARNING: Engine exhaust and some of its constituents are known to the State of California to cause cancer, birth defects, and other reproductive harm. For more information visit www.P65Warning.ca.gov	WARNING <i>Failure to follow cautious operating practices can result in serious injury to the operator or other persons. The owner must understand these instructions, and must allow only trained persons who understand these instructions to operate this vehicle.</i>
---	---

All **Smithco** machines have a Serial Number and Model Number. Both numbers are needed when ordering parts. Refer to engine manual for placement of engine serial number.

For product and accessory information, help finding a dealer, or to register your product please contact us at www.Smithco.com.

Information needed when ordering replacement parts:

1. Model Number of machine
2. Serial Number of machine
3. Name and Part Number of part
4. Quantity of parts

For easy access record your Serial and Model numbers here.

SMITHCO WAYNE, PENNSYLVANIA 19087 USA 610-688-4009 Fax 610-688-6069			
SERIAL NO. <input type="text"/>	kW/hp <input type="text"/>	DATE OF MFG. <input type="text"/>	
MODEL NO. <input type="text"/>	lb/kg Empty <input type="text"/>	lb/kg Full <input type="text"/>	

SMITHCO CUSTOMER SERVICE 1-800-891-9435

SAFE PRACTICES

1. It is your responsibility to read this manual and all publications associated with this machine (engine, accessories and attachments).
2. Never allow anyone to operate or service the machine or its attachments without proper training and instructions. Never allow minors to operate any equipment.
3. Learn the proper use of the machine, the location and purpose of all the controls and gauges before you operate the equipment. Working with unfamiliar equipment can lead to accidents.
4. Wear all the necessary protective clothing and personal safety devices to protect your head, eyes, ears, hands and feet. Operate the machine only in daylight or in good artificial light.
5. Inspect the area where the equipment will be used. Beware of overhead obstructions and underground obstacles. Stay alert for hidden hazards.
6. Never operate equipment that is not in perfect working order or without decals, guards, shields, or other protective devices in place.
7. Never disconnect or bypass any switch.
8. Carbon monoxide in the exhaust fumes can be fatal when inhaled, never operate a machine without proper ventilation.
9. Fuel is highly flammable, handle with care.
10. Keep engine clean. Allow the engine to cool before storing and always remove the ignition key.
11. After engine has started, machine must not move. If movement is evident, the neutral mechanism is not adjusted correctly. Shut engine off and readjust so the machine does not move when in neutral position.
13. Never use your hands to search for oil leaks. Hydraulic fluid under pressure can penetrate the skin and cause serious injury.
14. This machine demands your attention. To prevent loss of control or tipping of the vehicle:
 - A. Use extra caution in backing up the vehicle. Ensure area is clear.
 - B. Do not stop or start suddenly on any slope.
 - C. Reduce speed on slopes and in sharp turns. Use caution when changing directions on slopes.
 - D. Stay alert for holes in the terrain and other hidden hazards.
15. Before leaving operator's position for any reason:
 - A. Disengage all drives.
 - B. Lower all attachments to the ground.
 - C. Set park brake.
 - D. Shut engine off and remove the ignition key.
16. Keep hands, feet and clothing away from moving parts. Wait for all movement to stop before you clean, adjust or service the machine.
17. Keep the area of operation clear of all bystanders.
18. Never carry passengers.
19. Stop engine before making repairs/adjustments or checking/adding oil to the crankcase.
20. Use parts and materials supplied by **Smithco** only. Do not modify any function or part.

These machines are intended for professional maintenance on golf courses, sports turf, and any other area maintained turf and related trails, paths and lots. No guaranty as to the suitability for any task is expressed or implied.

SPECIFICATIONS FOR SWEEP STAR 48H

WEIGHTS AND DIMENSIONS

Length	121" (307 cm)
Width	60" (153 cm)
Height with Hopper Down	63" (160 cm)
Height with Hopper Up	126" (320 cm)
Wheel Base	70" (179 cm)
Weight	1900 lb (862 kg)

HIGH LIFT

SOUND LEVEL

At ear level	90 dB
--------------	-------

ENGINE

Make	Briggs & Stratton
Model#	356447
Type / Spec#	0263G1
Horsepower	18 Hp (13kW)
Fuel	Unleaded 87 Octane Gasoline Minimum
Cooling System	Air Cooled
Lubrication System	Full Pressure
Alternator	16 Amp

WHEELS & TIRE

Front:	One 18 x 9.50 x 8 Multi-rib (20 psi (1.4 bar))
Rear:	Two 22 x 11.00 - 10 4-ply (20 psi (1.4 bar))
Castor:	9 x 3.50 - 4 (20 psi (1.4 bar))

SPEED

Forward Speed	0 to 10 m.p.h. (0-16 kph)
Reverse Speed	0 to 4 m.p.h. (0-6 kph)

BATTERY

	Automotive IBS type 45-12 volt
BCI Group	Size 45
Cold Cranking Amps	480 minimum
Ground Terminal Polarity	Negative (-)
Maximum Length	9" (23 cm)
Maximum Width	5.38" (14 cm)
Maximum Height	9" (23 cm)

FLUID CAPACITY

Crankcase Oil	See Engine Manual
Fuel	6 gallon (22,7 liters)
Hydraulic Fluid	5 gallon (19 liters)
Grade of Hydraulic Fluid	SAE 10W-40 API Service SJ or higher Motor Oil

OPTIONAL EQUIPMENT

- 48-502 48" Brush Reel Kit (includes pillow blocks and pulley drive)
- 48-503 48" Finger Reel Kit (includes pillow blocks and pulley drive)
- 48-501 Hopper Dust Shield



MAINTENANCE

⚠ CAUTION

Before servicing or making adjustments to the machine, stop engine, set park break, block wheels and remove key from ignition.

⚠ IMPORTANT

Follow all procedures and **ONLY** use parts prescribed by the manufacturer. Read the engine manual before maintenance.

LUBRICATION

Use No. 2 General Purpose Lithium Base Grease and lubricate every 100 hours. The Sweep Star 48H has fifteen grease fittings.

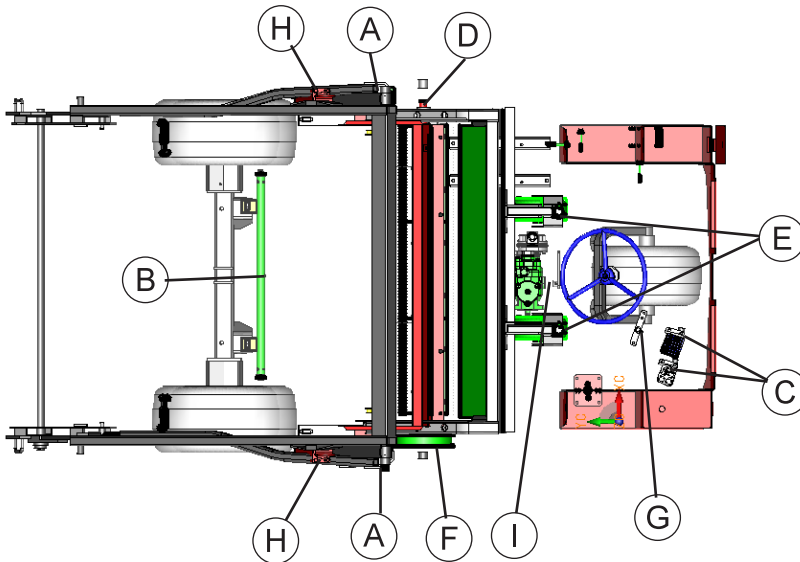

- A. One on the top of each tower.
- B. One on the center of park brake relay on rear axle.
- C. One on each pedal under the floorboard.
- D. One on the pillow block bearing on each end of finger/brush reel.
- E. One on caster wheel mount bracket.
- F. One on reel clutch relay. One on reel clutch belt tightener.
- G. One on pedal pivot arm.
- H. One on rod end of the tailgate cylinder.
- I. Pump idler Arm.

HYDRAULIC OIL

1. Use SAE 10W-40 API Service SG motor oil.
2. For proper warranty, change oil every 500 hours or annually, whichever is first and change the filter after the first 50 hours, then every 250 hours thereafter.
3. The oil level should be 2" to 2 1/2" (5 - 6.4 cm) from top of fill neck when fluid is cold. Do not overfill.
4. After changing oil and/or filter, run the machine for a few minutes. Check oil level and for leaks.
5. Always use caution when filling hydraulic oil tank or checking level to keep system free of contaminants. Check and service more frequently when operating in extremely cold, hot or dusty conditions.
6. If natural color of fluid is now black or smells burnt, it is possible that an overheating problem exists.
7. If fluid becomes milky, water contamination may be a problem.
8. If either of the above conditions happen, change oil and filter immediately after fluid is cool and find cause. Take fluid level readings when system is cold.
9. In extreme temperatures you can use straight weight oil. We recommend SAE 30W API Service SG when hot (above 90°F (33°C)) and SAE 10W API Service SG when cold (below 32°F (0°C)) ambient temperature. Use either motor oil or hydraulic oil, but do not mix.
10. Oil being added to the system must be the same as what is already in the tank. Mark tank fill area as to which type you put in.

ENGINE OIL

Change and add oil according to chart below. Do not overfill. Engine oil capacity is 2 quarts. We recommend high-quality detergent oils classified for service SF, SG, SH, SJ or higher. Do not use special additives. Outdoor temperatures determine the proper oil viscosity for the engine. Use the chart to select the best viscosity for the outdoor temperature range expected.

SAE Viscosity Grades

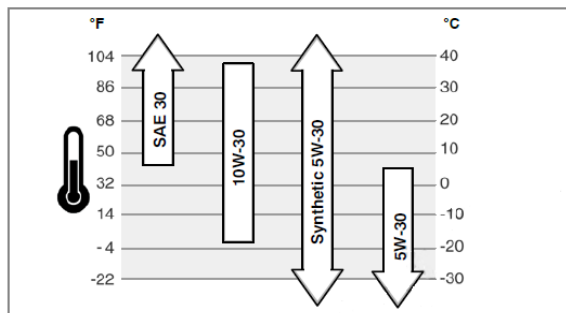

Use of multi-viscosity oils (10W-30, etc.) above 80° F (27° C) will result in high oil consumption and possible engine damage. Check oil level more frequently if using these types of oils.

SAE 30 oil, if used below 40° F (4° C), will result in hard starting and possible engine bore damage due to inadequate lubrication.



MAINTENANCE

TIRE PRESSURE

Caution must be used when inflating a low tire to recommended pressure. Over inflating can cause tires to explode. Front and rear tires and caster wheel should be 20 psi (1.4bar) maximum. Improper inflation will reduce tire life considerably.

WHEEL MOUNTING PROCEDURE

REAR WHEELS

1. Set park brake. Turn machine off and remove key.
2. Block one of the other wheels.
3. Loosen nuts slightly on wheel to be removed.
4. Jack up machine being careful not to damage underside of machine.
5. Remove nuts, remove wheel.
5. Place new wheel on hub lining up bolt holes.
6. Torque nuts to 64-74 ft/lb (87-100Nm) using a cross pattern. Re-torque after first 8 hours and every 250 hours thereafter.
7. Lower machine to ground and remove blocks and jack.

FRONT WHEEL

1. Set park brake. Turn machine off and remove key.
2. Block one of the other wheels.
3. Remove cotter pins from each end of the axle.
4. Remove axle nuts, machine bushings and axle locks.
5. Jack up front of machine being careful not to damage underside of machine.
6. Wheel and axle will come out of slots in the u-bracket, pull wheel forward.
7. Place new wheel on hub lining up bolt holes.
8. Torque nuts to 64-74 ft/lb (87-100Nm) using a cross pattern. Re-torque after first 8 hours and every 250 hours thereafter.
9. Place wheel back on front fork. Tighten all bolts.
10. Lower machine to ground and remove blocks and jack.

SWEEPING

While sweeping close tailgate frequently to ensure tailgate does not creep open. While operating the sweeper head it is important to disengage the head before raising. If the sweeper head is raised while engaged, it can cause the belt to slip off the pulleys. This can result in belt failure and engine crankshaft failure.

DISENGAGE THE SWEEPER HEAD BEFORE RAISING.

BATTERY

Batteries normally produce explosive gases which can cause personal injury. Do not allow flames, sparks or any ignited object to come near the battery. When charging or working near battery, always shield your eyes and always provide proper ventilation.

Battery cable should be disconnected before using "Fast Charge".

Charge battery at 15 amps for 10 minutes or 7 amps for 30 minutes. Do not exceed the recommended charging rate. If electrolyte starts boiling over, decrease charging.

Always remove grounded (-) battery clamp first and replace it last. Avoid hazards by:

1. Filling batteries in well-ventilated areas.
2. Wear eye protection and rubber gloves.
3. Avoid breathing fumes when electrolyte is added.
4. Avoid spilling or dripping electrolyte.

WARNING

Battery Electrolyte is an acidic solution and should be handled with care. If electrolyte is splashed on any part of your body, flush all contact areas immediately with liberal amounts of water. Get medical attention immediately.

JUMP STARTING

WARNING

Use of booster battery and jumper cables. Particular care should be used when connecting a booster battery. Use proper polarity in order to prevent sparks.

To jump start (negative grounded battery):

1. Shield eyes.
2. Connect ends of one cable to positive (+) terminals of each battery, first (A) then (B).
3. Connect one end of other cable to negative (-) terminal of "good" battery (C).
4. Connect other end of cable (D) to engine block on unit being started (NOT to negative (-) terminal of battery)

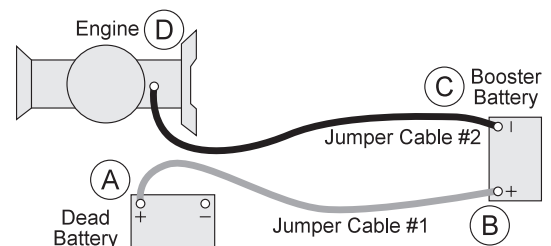

To prevent damage to other electrical components on unit being started, make certain that engine is at idle speed before disconnecting jumper cables.

TOWING

When it is necessary to move the Sweep Star 48H without engine running, the bypass valve built into hydrostatic pump must be "open" by turning it $\frac{1}{4}$ turn. An "open" valve allows fluid to pass through the wheels freely. When normal, driven, operation is desired, valve should be closed by turning it $\frac{1}{4}$ turn. Failure to "close" the valve with engine running means no power to wheels. Tow slowly. 2 m.p.h. or less.

The bypass valve is a $\frac{3}{8}$ diameter shaft with two flat spots on the sides so you can turn it. On the high lift it is on the top of the hydrostatic.

FILTER PACK

Filters can be removed and cleaned by shaking or use a low pressure water hose. Filter will disintegrate if cleaned under high pressure.



SERVICE CHART

⚠ CAUTION

Before servicing or making adjustments to the machine, stop engine, set park break, block wheels and remove key from ignition.

⚠ IMPORTANT

Follow all procedures and **ONLY** use parts prescribed by the manufacturer. Read the engine manual before maintenance.

The suggested maintenance checklist is not offered as a replacement for the manufacturer's engine manual but as a supplement. You must adhere to the guidelines established by the manufacturer for warranty coverage. In adverse conditions such as dirt, mud or extreme temperatures, maintenance should be more frequent.

Maintenance Service Interval	Maintenance Procedure
After the first 8 operating hours	Torque the wheel lug nuts. (64-74 ft/lb (87-100 Nm))
	Change the engine oil filter.
Before each use daily	Check the engine oil level.
	Clean area around muffler and controls.
	Check the hydraulic fluid level.
	Check the tire pressure.
	Check and clean Debris Filter Pack1
	Check condition of hydraulic hoses and fittings.
	Inspect and clean the machine.
After the first 50 hours	Change Hydraulic Oil Filter.
Every 100 hours	Clean or change air filter.1
	Clean pre-cleaner.1
	Change engine oil and filter.
	Replace spark plug .
	Lubricate machine.
	Clean or change remote air cleaner.
	Check the battery fluid level and cable connections..
	Check muffler and spark arrestor.
Check belt tension .	
Every 250 hours	Check engine valve clearance and adjust if necessary.
	Check idle speed.
	Clean battery terminals.
	Change hydraulic oil filter.
	Torque the wheel lug nuts. (64-74 ft/lb (87-100 Nm))
Every 500 hours or yearly	Change fuel filter.
	Change hydraulic oil and filter.
	Clean oil cooler fins.1
	Clean air cooling system.1
	Check safety filter in remote air cleaner.
1 In dusty conditions or when airborne debris is present, clean more often.	

MAINTENANCE CHART

Duplicate this page for routine use.

Maintenance Check Item	For the week of:						
	Mon	Tues.	Wed.	Thurs.	Fri.	Sat.	Sun.
Check the Safety Seat Switch							
Check Steering Operation							
Check the fuel level							
Check the engine oil level.							
Clean the air filter							
Clean the engine cooling fins.							
Check for unusual engine noises							
Check the hydraulic oil level							
Check hydraulic hoses and fittings for damage							
Check for fluid leaks.							
Check the tire pressure							
Check the Instrumentation							
Inspect electrical system for frayed wires							
Check park brake adjustment							
Change oil filter.							
Change oil.							
Lubricate Machine							
Ensure all warning decals are intact.							
Areas of Concern							
Inspection Performed by:							
Item	Date	Information					

Service



ADJUSTMENTS

PARK BRAKE ADJUSTMENT

By turning knob on end of park brake lever you can tighten or loosen brake a small amount. To tighten turn the knob clockwise. To loosen turn counter clockwise. If this is not enough turn clevis on the rear of the brake cable to adjust length of cable. Do not adjust the clevis on the front of the machine.

STEERING CHAIN ADJUSTMENT

Steering Sprockets (A) should be level with each other. Check with straight edge. Make any adjustments. Slide Idler Pulley (B) so that it is snug onto the chain. Tighten all nuts and bolts in place.

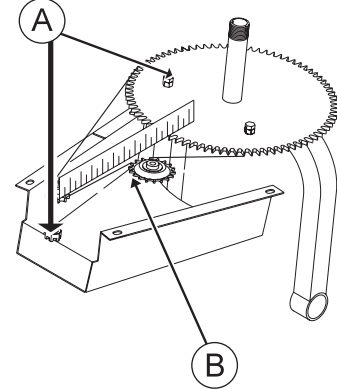

WHEEL 'CREEP' ADJUSTMENT

'Creep' is when engine is running and hydrostatic transmission is in neutral, but due to inadequate alignment, wheels still move. Do the following procedures to stop this motion.

1. Lift up and support machine so rear wheels are off the ground and can turn freely.
2. Below the seat is the engine compartment. The shift arm (D) is on the side of the pump. The idler arm (F) is attached to the pump mount bracket and has an idler pulley (C) that runs in the "y" of the shift arm. Loosen bolt (E).
3. With engine running, move idler pulley (C) so it centers on the shift arm (D) and 'wheel creep' stops.
4. Tighten all fasteners and test by using foot pedal linkage to see that 'creep' is removed.
5. Turn engine off and lower machine.

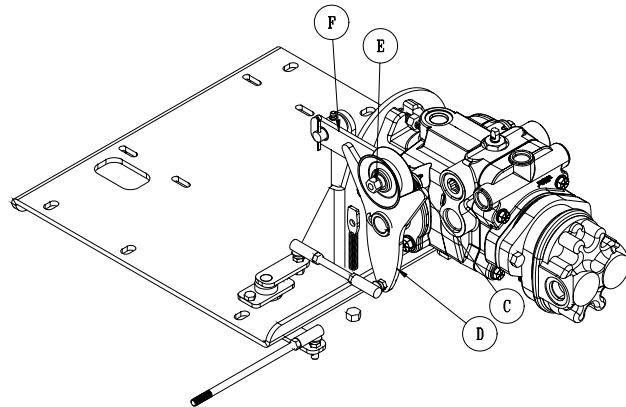

RUBBER FINGERS AND NYLON BRUSHES

In normal use, rubber fingers and nylon brushes wear out and require replacement. They will break, dislodge, and wear prematurely if used in less than ideal conditions.

STORAGE

When storing, remove the key from the key switch to avoid unauthorized persons from operating machine.

1. Before storing clean machine thoroughly.
2. Check bolts and nuts, tighten as necessary.
3. Make all repairs that are needed and remove any debris.
4. Remove the battery, adjust the electrolyte level and recharge it. Store the battery in a dry, dark place.
5. Store in a clean and dry area, but NOT near a stove, furnace or water heater which uses a pilot light or any device that can create a spark.
6. Engines stored over 30 days need to be protected or drained of fuel to prevent gum from forming in a fuel system or on essential carburetor parts. Check the engine manual and follow the instructions for the storage of the engine.

REEL HEIGHT ADJUSTMENT

Below are the various ways that the Sweep Star 48H caster wheels can be adjusted to accommodate for the finger/brush reel height. By changing the two spacers around on the caster wheel fork you can experience a range of ground clearances on the finger/brush reel. Keep both caster wheels at the same height.

⚠ CAUTION

These clearances change as the brush and finger reels wear.

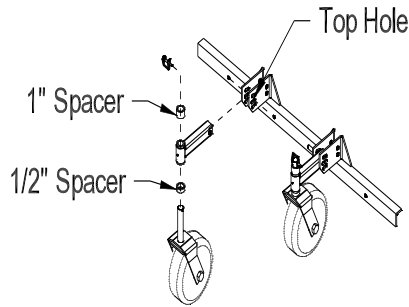

1/2" Spacer
 Top Hole
Ground Clearance
 Brush Reel $\frac{3}{4}$ "
 Finger Reel $1\frac{1}{8}$ "

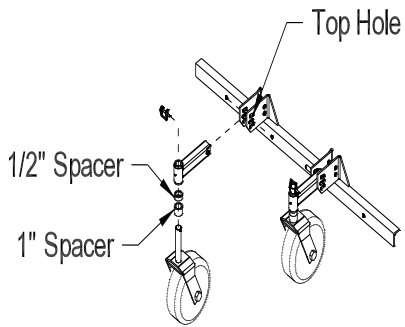

1" Spacer
 1/2" Spacer
 Top Hole
Ground Clearance
 Brush Reel $1\frac{1}{8}$ "
 Finger Reel $1\frac{7}{16}$ "

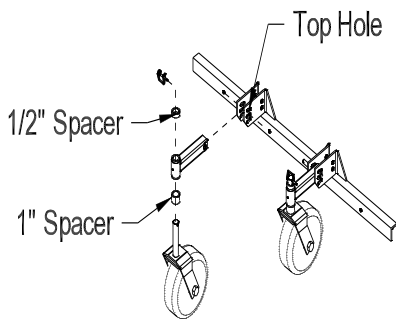

1" Spacer
 Top Hole
Ground Clearance
 Brush Reel $\frac{5}{8}$ "
 Finger Reel $1\frac{1}{4}$ "

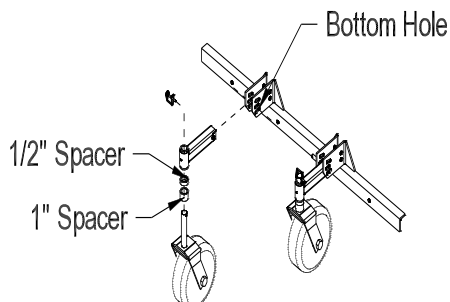

1" Spacer(2 per)
 1/2" Spacer(1 per)
 Bottom Hole
Ground Clearance
 Brush Reel $1\frac{1}{2}$ "
 Finger Reel $1\frac{7}{8}$ "



WIRING DIAGRAM

Color Code Chart

Bl	Blue
Br	Brown
Y	Yellow
Grn	Green
O	Orange
R	Red
B	Black
P	Purple

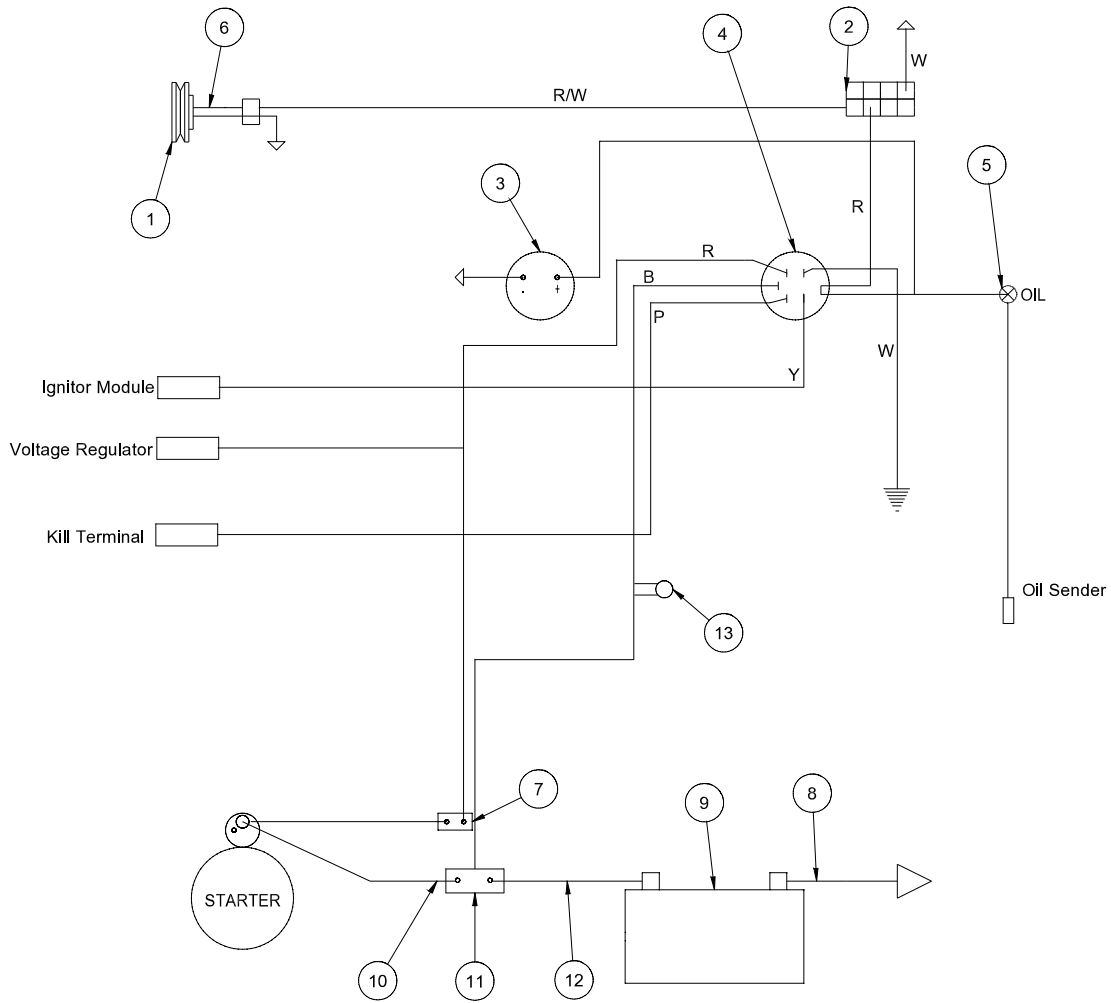

WIRING DIAGRAM PARTS LIST

REF#	PART#	DESCRIPTION	QUANTITY
1	76-337	Electric Clutch	1
2	15-725	Mount Panel End	1
	15-726	Lighted Switch, On-None-Off	1
	15-732	Rocker Switch, Green	1
3	12-804	Hour Meter	1
4	13-488	Key Switch with Hardware	1
5	50-359	Warning Indicator Light	1
6	17-271	Pigtail	1
7	8975	Circuit Breaker, 30 amp	1
	8977	Circuit Breaker Boot	1
8	48-268	Black Battery Cable	1
9	22-073	Battery	1
	48-166	Battery Hold-down	1
10	22-065	Black Starter Cable	1
11	13-750	Solenoid with Connector	1
12	48-157	Red Battery Cable	1
13	14-292	Seat Switch	1
	48-511	Wire Harness	1
	8874	Line Connector Blue (Voltage Regulator)	1
	8875	Bullet Terminal (Ignition Module)	1
	8963	Heat Shrink	2

HYDRAULIC DIAGRAM

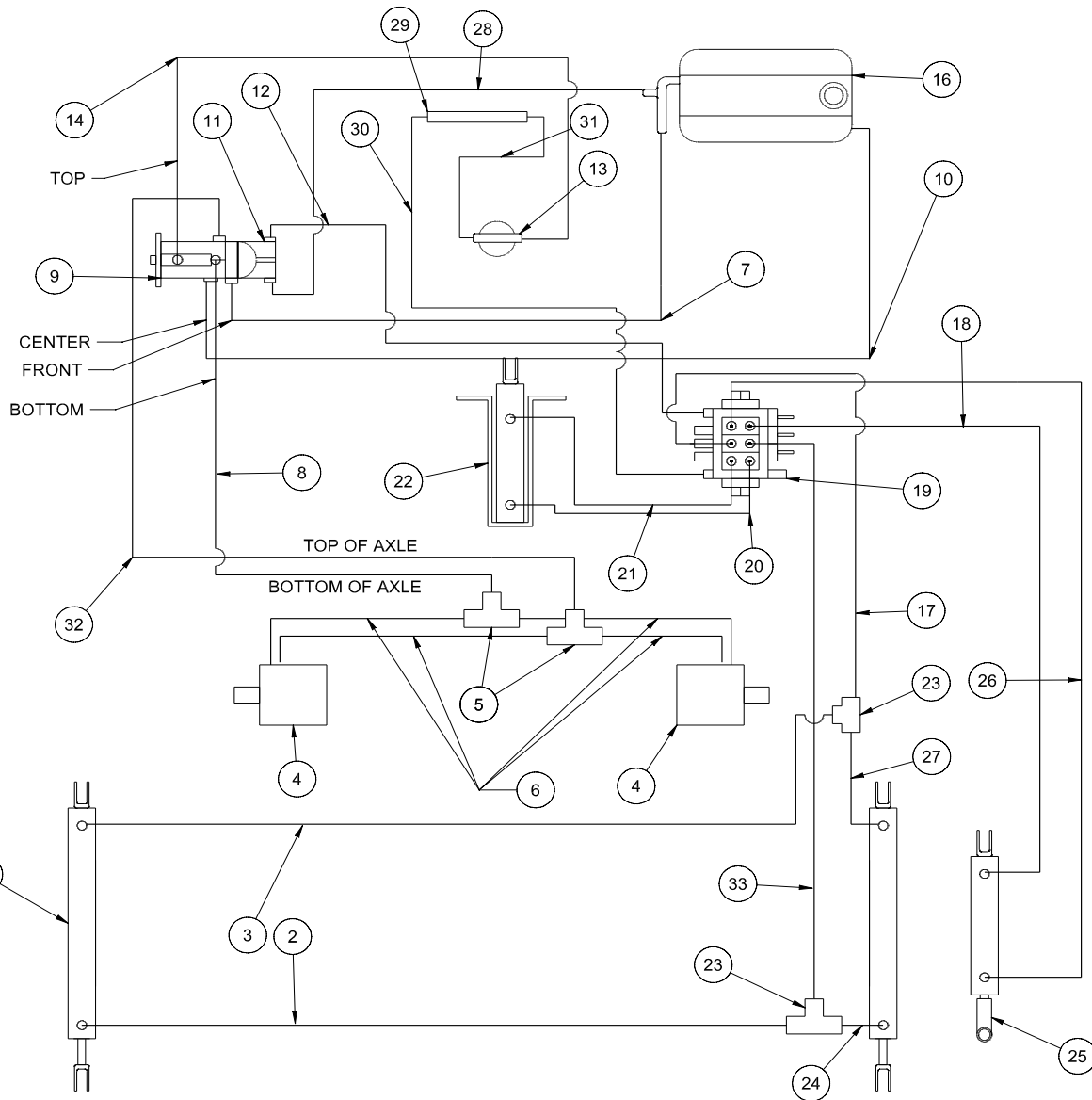

48-267 Hydrostatic Pump

Displacement	Variable to 1.44 in ³ /R (23.6 cm ³ /R)
	22.44 gpm (84.94 lpm) at 3600 rpm
Max Operating Speed	3600 rpm
Rated Pressure	3000 psi (206.8 bar)
Max Pressure	5000 psi (344.7 bar)
Max Inlet Vacuum	6 in Hg (.203 bar)
Max Inlet Temperature	225°F (107°C)
Max Allowable Case Pressure	25 psi (1.72 bar)

48-266 Gear Pump

Displacement	.40 in ³ /R (6.6 cm ³ /R) 6.23 gpm (25.39 lpm)
--------------	--

HYDRAULIC DIAGRAM PARTS LIST

REF#	PART#	DESCRIPTION	QUANTITY
1	76-627	Hydraulic Cylinder	2
	76-242-01	Seal Kit	
2	48-012	Hydraulic Hose, 80"	1
3	48-013	Hydraulic Hose, 60"	1
4	76-238	Wheel Motor	2
5	34-057	Tee	2
6	48-244	Hydraulic Tube	4
7	8832-12.5	Suction Hose, 3/4 ID x 12.5"	1
	18-040	Hose Clamp	2
8	48-257	Hydraulic Hose, 77"	2
9	48-267	Hydrostatic Pump	1
10	8832-42.5	Suction Hose, 3/4 ID x 42.5"	1
	18-040	Hose Clamp	2
11	48-266	Gear Pump (replacement; no repair)	1
12	48-253	Hydraulic Hose, 56"	1
13	20-576	Oil Filter	1
	20-576-01	Filter Element (replacement only)	1
14	8832-15	Suction Hose, 3/4 ID x 15"	1
	18-040	Hose Clamp	2
16	60-473	Oil Tank	1
17	48-249	Hydraulic Hose, 65"	1
18	48-252	Hydraulic Hose, 150"	1
19	48-258	3-Bank Hydraulic Valve	1
20	48-255	Hydraulic Hose, 44"	1
21	48-256	Hydraulic Hose, 41"	1
22	76-478	Hydraulic Cylinder	1
	14-531	Seal Kit	
23	18-173	Tee 3/8 Junction Union	2
24	27-065	Hydraulic Hose, 26"	1
25	10-554	Hydraulic Cylinder	1
	14-529	Seal Kit	
26	48-248	Hydraulic Hose, 147"	1
27	48-014	Hydraulic Hose, 10.5"	1
28	8832-20	Suction Hose, 3/4 ID x 20"	1
	18-040	Hose Clamp	2
29	45-382	Oil Cooler	1
30	48-251	Hydraulic Hose, 38"	1
31	48-250	Hydraulic Hose, 44"	1
32	48-247	Hydraulic Hose, 92"	1
33	48-254	Hydraulic Hose, 63"	1

SMITHCO ENGINEERED ROLL OVER DRAWING

Diagrams

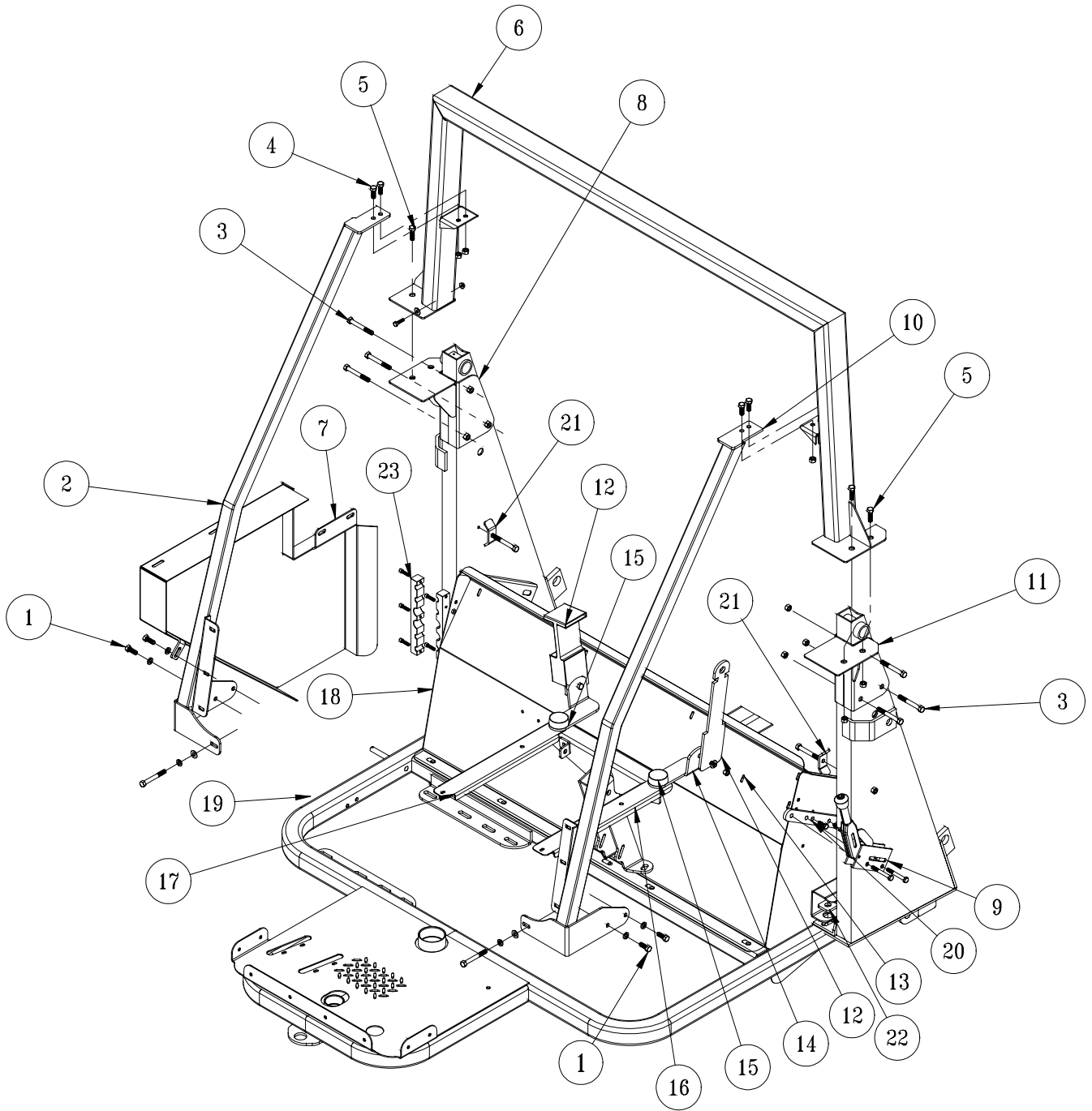

SMITHCO ENGINEERED ROLL OVER PARTS LIST

REF#	PART#	DESCRIPTION	QUANTITY
1	HB-38-16-100	Hex Bolt, $\frac{3}{8}$ - 16 x 1	4
	HWL-38	Lock Washer, $\frac{3}{8}$ - 16	4
2	48-295	Left Support Bar	1
3	HB-12-13-300	Hex Bolt, $\frac{1}{2}$ -13 x 3	6
	HNTL-12-13	Nylon Lock Nut, $\frac{1}{2}$ -13	6
4	HB-38-16-100	Hex Bolt, $\frac{3}{8}$ - 16 x 1	4
	HNTL-38-16	Nylon Lock Nut, $\frac{3}{8}$ -16	4
5	HB-12-13-125	Hex Bolt, $\frac{1}{2}$ -13 x $1\frac{1}{4}$	4
	HNTL-12-13	Nylon Lock Nut, $\frac{1}{2}$ - 13	4
6	48-208	Roll Bar	1
7	48-313	Belt Guard	1
8	48-207	Left Hand Mount	1
	25-286	Decal, Pinch Point	3
9	60-106	Brake Lever	1
10	48-294	Right Support Bar	1
11	48-206	Right Hand Mount	1
12	76-198-03	Seat Belt	1
13	HBCL-38-16-100	Carriage Hex Bolt, $\frac{3}{8}$ - 16 x 1	2
	HNTL-38-16	Nylon Lock Nut, $\frac{3}{8}$ - 16	2
	HW-38	Flat Washer, $\frac{3}{8}$	2
14	48-287	Left Seat Belt Bracket	1
15	50-081	Rubber Bumper	2
16	48-284	Left Seat Brace	1
17	48-285	Right Seat Brace	1
18	48-307	Grass Chute	1
	8803-47	Black Trim	1
19	48-300	Main Frame	1
20	48-324	Park Brake Handle Mount	1
	HB-516-18-225	Hex Bolt, $\frac{5}{16}$ -18 x $2\frac{1}{4}$	2
	HNFL-516-18	Flange Whiz-loc Nut, $\frac{5}{16}$ -18	2
21	13-099	Hose Clamp	1
	HB-516-18-125	Hex Bolt, $\frac{5}{16}$ -18 x $1\frac{1}{4}$	1
	HNFL-516-18	Flange Whiz-loc Nut, $\frac{5}{16}$ -18	1
22	76-151	Washer	4
23	76-336	Hose Clamp w/ Hardware	1

NOSE CONE DRAWING

PARTS

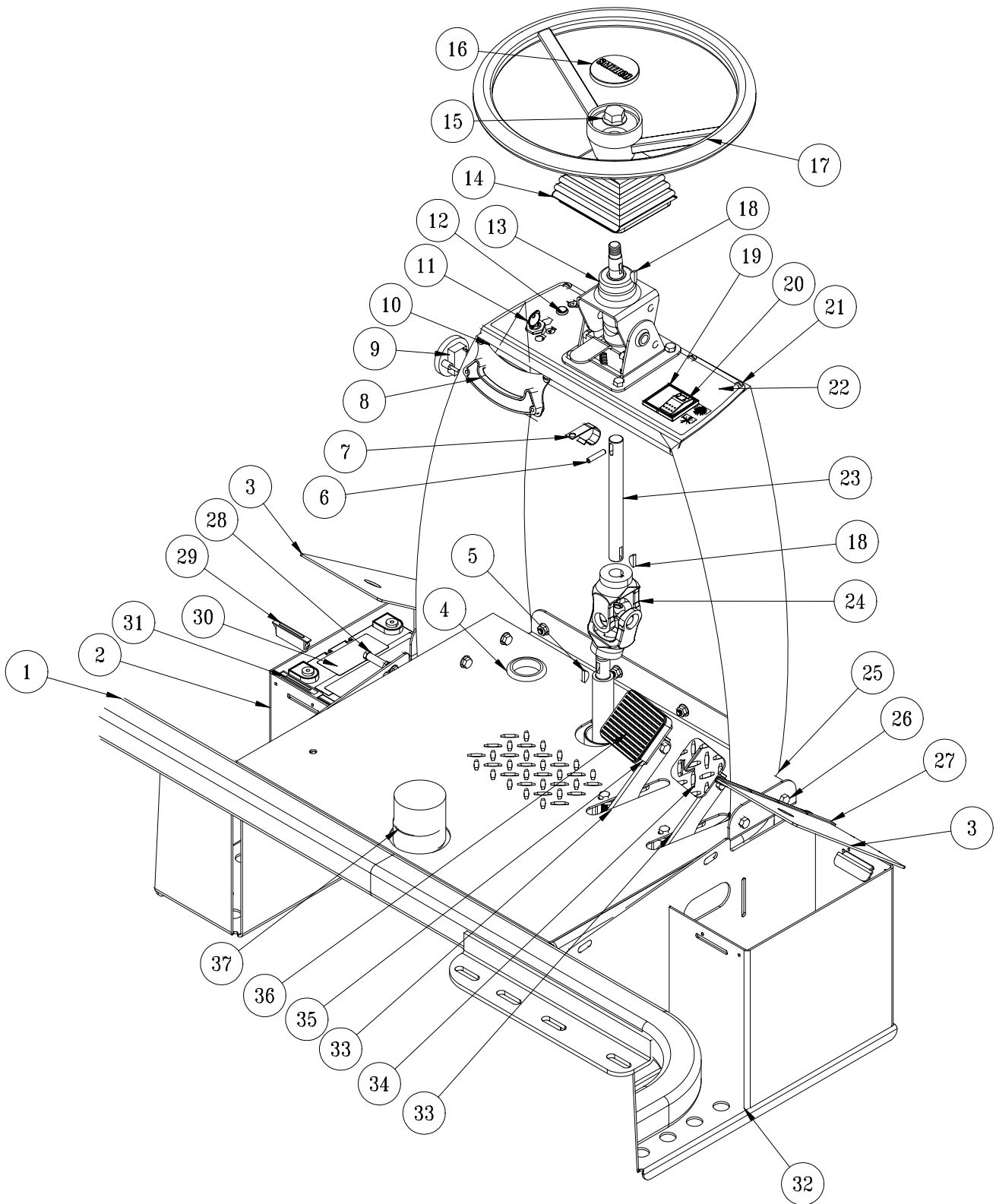

NOSE CONE PARTS LIST

REF#	PART#	DESCRIPTION	QUANTITY
1	48-300	Main Frame	1
2	48-293	Left Step	1
	HB-38-16-300	Hex Bolt, $\frac{3}{8}$ -16 x 3	3
	HW-38	Flat Washer, $\frac{3}{8}$	3
	HNTL-38-16	Nylon Lock Nut, $\frac{3}{8}$ -16	3
3	48-159	Battery Box Cover	2
4	50-400	Rubber Grommet	1
5	HWK-316-063	Woodruff Key, $\frac{3}{16}$ x $\frac{5}{8}$	1
6	HRP-14-150	Roll Pin, $\frac{1}{4}$ x $1\frac{1}{2}$	1
7	HLC-A-58	Loom Clamp	1
8	76-372	Inclinometer	1
	HSM-8-32-100	Machine Screw, 8 - 32 x 1	2
	HNFL-8-32	Flange Whiz-loc Nut, 8 - 32	2
9	12-804	Hour Meter	1
10	76-373	Inclinometer Bracket	1
11	13-488	Ignition Switch	1
12	50-359	Warning Indicator Light	1
13	76-362	Mini Tilt Steering	1
14	76-364	Tilt Steering Boot	1
15	HNJ-58-18	Jam Nut, $\frac{5}{8}$ - 18	1
16	13-726	Center Cap	1
	27-077	Decal, Smithco	1
17	13-718	15" Steering Wheel	1
18	HWK-316-075	Woodruff Key, $\frac{3}{16}$ x $\frac{3}{4}$	2
19	15-725	Mount Panel End	1
	15-730	Mount Panel Plug	1
20	15-725	Mount Panel End	1
	15-726	Lighted Switch, On-None-Off	1
	15-732	Rocker, Green	1
21	HSM-10-32-075	Machine Screw, 10 - 32 x $\frac{3}{4}$	7
	HNFL-10-32	Flange Nut, 10 -32	7
22	48-274	Dashboard Panel	1
	48-245	Decal, Dash Panel	1
23	42-760	Top Steering Shaft	1
24	75-833	Universal Joint	1
	HSSHS-516-18-038	Socket Head Set Screw, $\frac{5}{16}$ - 18 x $\frac{3}{8}$	4
25	48-263	Nose Cone	1
26	HSTP-516-18-100	Truss Head Screw, $\frac{5}{16}$ - 18 x 1	8
	HNFL-516-18	Flange Whiz-loc Nut, $\frac{5}{16}$ -18	8
27	8803-10	Black Trim	2
28	48-166	Battery Hold-down	1
29	48-164	Magnet	2
30	22-073	Battery	1
31	48-165	Magnet Bracket	2
	HRS-18-050	Rivet, $\frac{1}{4}$ x $\frac{1}{2}$	4
	HW-6	Flat Washer, #6	4
32	48-292	Right Step	1
	HB-38-16-300	Hex Bolt, $\frac{3}{8}$ -16 x 3	3
	HW-38	Flat Washer, $\frac{3}{8}$	3
	HNTL-38-16	Nylon Lock Nut, $\frac{3}{8}$ -16	3
33	48-311	Foot Pedal	2
34	48-312	Reverse Pedal Pad	1
35	16-062	Pedal Pad Plate	1
36	15-015	Pedal Pad	1
37	76-301	Rubber Cap	1

STEERING DRAWING

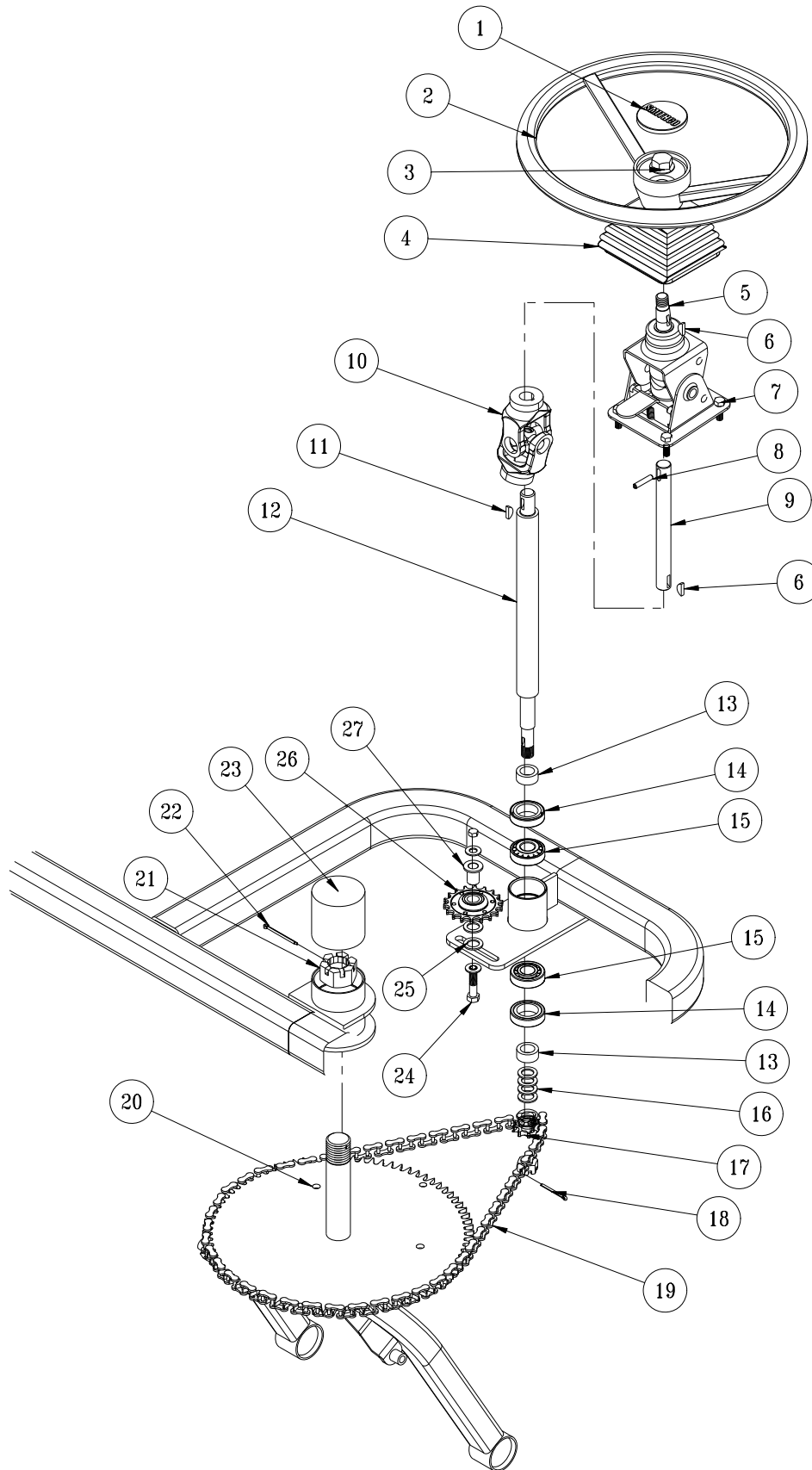

Parts

STEERING PARTS LIST

REF#	PART#	DESCRIPTION	QUANTITY
1	13-726	Steering Wheel Cap	1
2	13-718	Steering Wheel	1
3	HNJ-58-18	Jam Nut, $\frac{5}{8}$ - 18	1
4	76-364	Tilt Steering Boot (comes with 76-362)	1
5	76-362	Tilt Steering Mechanism	1
6	HWK-316-075	Woodruff Key, $\frac{3}{16}$ x $\frac{3}{4}$	2
7	HB-516-18-100	Hex Bolt, $\frac{5}{16}$ - 18 x 1	4
	HNFL-516-18	Flange Whiz-loc Nut, $\frac{5}{16}$ - 18	4
8	HRP-14-150	Roll Pin, $\frac{1}{4}$ x $1\frac{1}{2}$	1
9	42-760	Top Steering Shaft	1
10	75-833	Universal Joint	1
	HSSHS-516-18-038	Socket Head Set Screw, $\frac{5}{16}$ - 18 x $\frac{3}{8}$	4
11	HWK-316-063	Woodruff Key, $\frac{3}{16}$ - $\frac{5}{8}$	1
12	48-260	Bottom Steering Shaft	1
13	11-040	Spacer, $\frac{3}{4}$	2
14	11-039	Seal	2
15	11-038	Bearing Cup and Cone	2
16	HMB-58-14	Machine Bushing, $\frac{5}{8}$ - 14	as Req'd
17	76-153	Sprocket	1
18	HNA-58-18	Axle Nut, $\frac{5}{8}$ - 18	1
	HP-18-100	Cotter Pin, $\frac{1}{8}$ x 1	1
19	8827-55	Roller Chain	1
	18-032	Master Link, #40	1
20	76-155	Front Fork	1
21	HNA-114-12	Axle Nut, $1\frac{5}{4}$ - 12	1
22	HP-18-200	Cotter Pin, $\frac{1}{8}$ x 2	1
23	76-301	Rubber Cap	1
24	HB-38-16-175	Hex Bolt, $\frac{3}{8}$ - 16 x $1\frac{3}{4}$	1
	HW-38	Flat Washer, $\frac{3}{8}$	1
	HWL-38	Lock Washer, $\frac{3}{8}$	1
	HN-38-16	Hex Nut, $\frac{3}{8}$ - 16	1
25*	HMB-58-14	Machine Bushing, $\frac{5}{8}$ - 14	2
26*	18-511	Idler Sprocket	1
27*	18-043	Flange Buhsing	1
-	76-759	Idler Pulley Kit	

FRONT FORK DRAWING

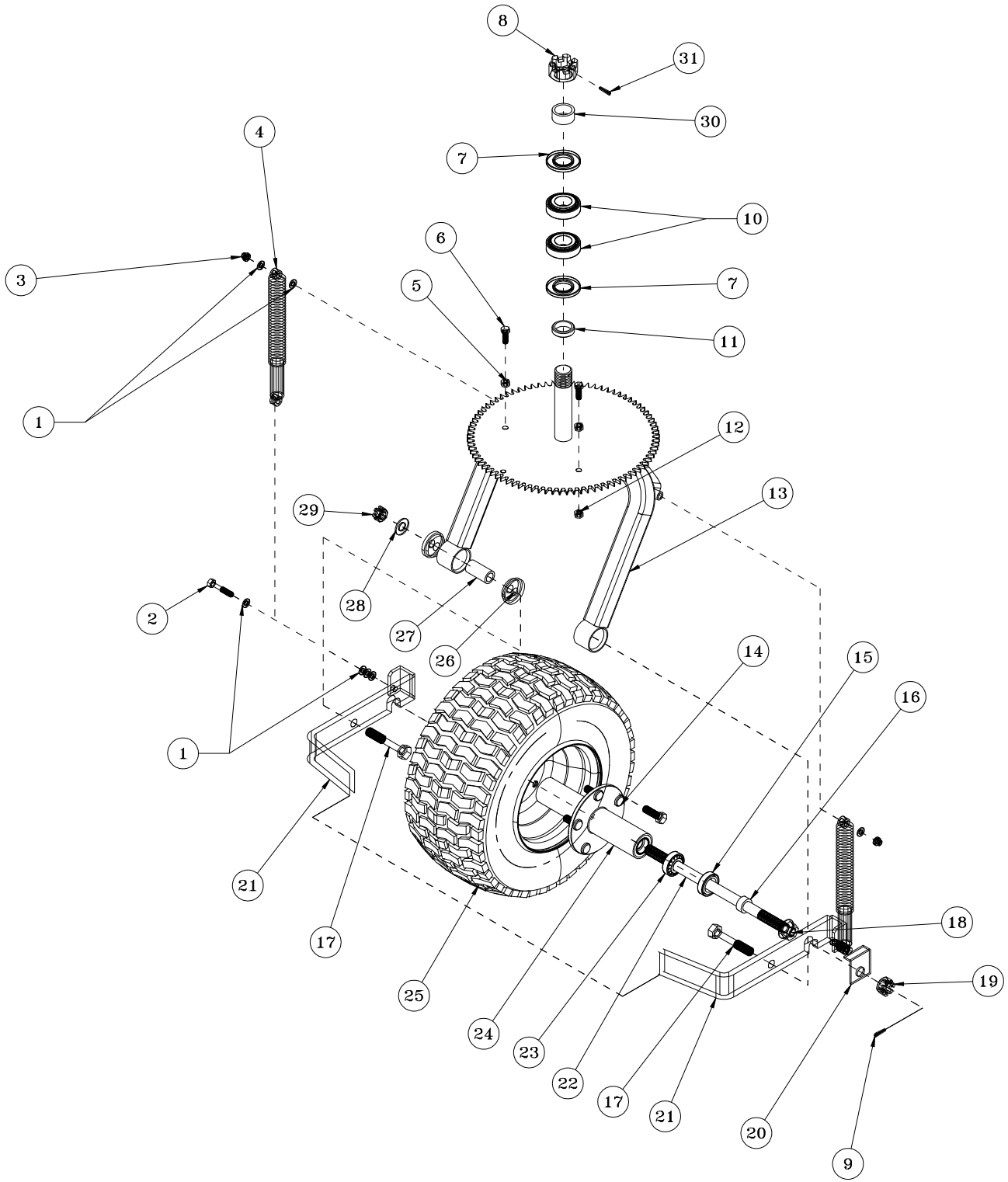

Parts

FRONT FORK PARTS LIST

REF#	PART#	DESCRIPTION	QUANTITY
1	HW-38	Flat Washer, $\frac{3}{8}$ (as Req'd)	14
2	HB-38-16-200	Hex Bolt, $\frac{3}{8}$ - 16 x 2	2
	HNTL-38-16	Nylon Lock Nut, $\frac{3}{8}$ - 16	2
3	HB-38-16-250	Hex Bolt, $\frac{3}{8}$ - 16 x 2 $\frac{1}{2}$	2
	HNTL-38-16	Nylon Lock Nut, $\frac{3}{8}$ - 16	2
4	75-715	Shock Absorber	2
	75-864	Bushing (comes with shock)	2 per shock
5	HN-38-16	Hex Nut, $\frac{3}{8}$ - 16	2
6	HB-38-16-100	Hex Bolt, $\frac{3}{8}$ - 16 x 1	2
7	20-142	Grease Seal, $\frac{1}{4}$	2
8	HNA-114-12	Axle Nut, $\frac{1}{4}$ - 12	1
9	HP-18-100	Cotter Pin, $\frac{1}{8}$ x 1	2
10	20-143	Bearing Cup and Cone, $\frac{1}{4}$ ID	2
11	20-141	Spacer, $1\frac{5}{8}$ OD x $\frac{1}{4}$ ID x $\frac{7}{16}$	1
12	HNCL-38-16	Nylon Lock Nut, $\frac{3}{8}$ - 16	2
13	76-155	Front Fork	1
14	27-022-02	Hex Bolt Stud, $\frac{1}{2}$ - 20 x $1\frac{1}{2}$	5
	HNL-12-20	Lug Nut, $\frac{1}{2}$ - 20	5
15	11-039	Grease Seal, $\frac{1}{8}$ ID	2
16	11-040	Spacer, $1\frac{1}{8}$ OD x $\frac{3}{4}$ ID x $\frac{17}{32}$	2
17	HBC-11-18-350	Carriage Bolt, $\frac{5}{8}$ - 11 x $3\frac{1}{2}$	2
18	HNJ-34-16	Jam Nut, $\frac{3}{4}$ - 16	2
19	HNA-34-16	Axle Nut, $\frac{3}{4}$ - 16	2
	HMB-34-10	Machine Bushing, $\frac{3}{4}$ x 10GA	2
20	60-511	Axle Lock	2
21	60-728	U-Bracket Kit	1
22	60-407	Front Axle	1
23	11-038	Bearing Cup and Cone, $\frac{3}{4}$ ID	2
24	11-010	Wheel Hub (comes with 11-038 and 11-039)	1
25	60-130	Wheel and Tire	1
	60-130-01	Tire, 18 x 9.5 - 8	1
	60-130-02	Wheel	1
	8839	Windshield Washer Fluid	28 pints
26	60-128	Rubber Bushing	4
27	60-406	Spacer, 1 OD x $\frac{5}{8}$ ID x 2	2
28	HW-58	Washer, $\frac{5}{8}$	2
29	HNTL-58-11	Nylon Lock Nut, $\frac{5}{8}$ - 11	2
30	76-158	Spacer Seal	1
31	HP-18-200	Cotter Pin, $\frac{1}{8}$ x 2	1

LINKAGE DRAWING

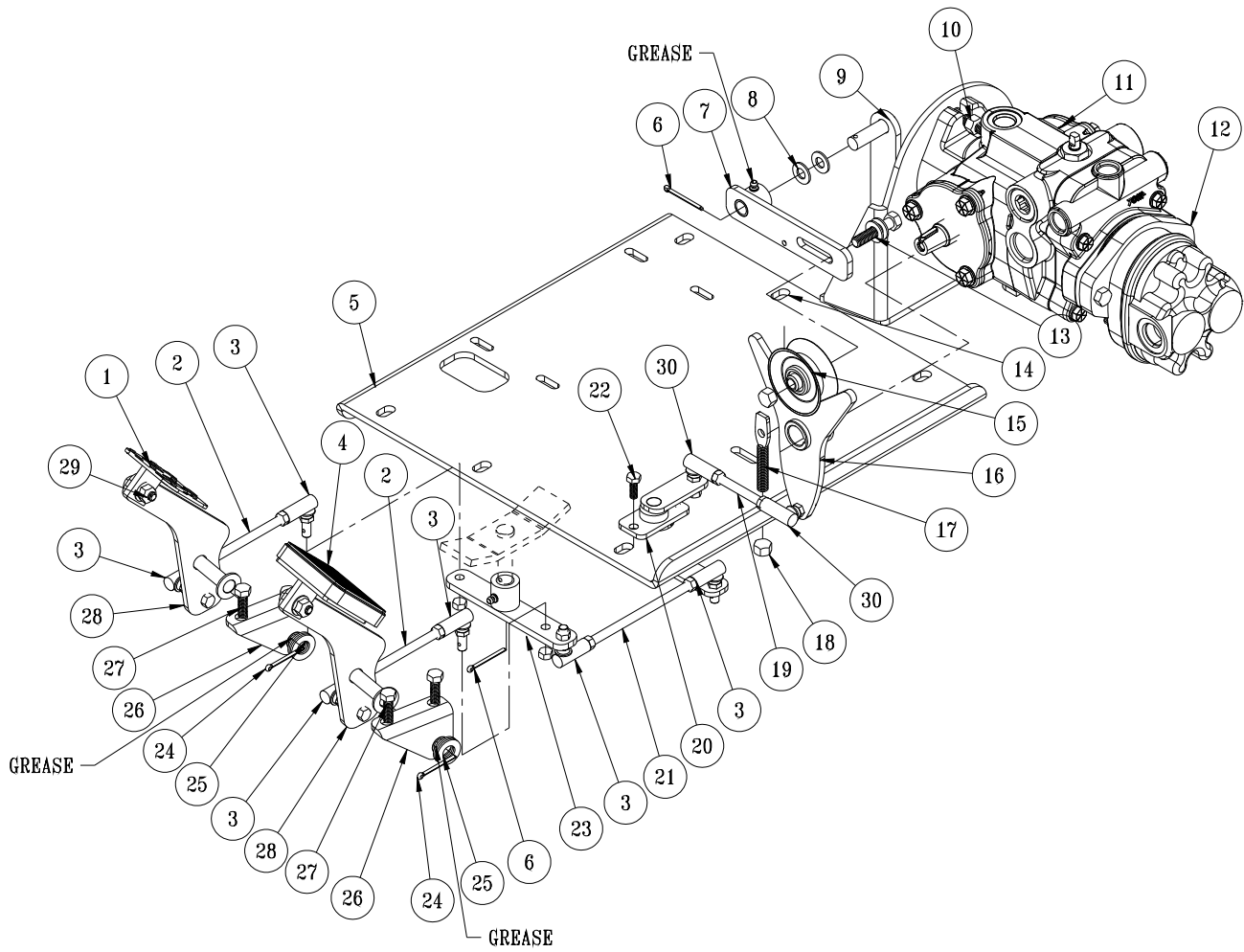

LINKAGE PARTS LIST

REF#	PART#	DESCRIPTION	QUANTITY
1	48-312	Reverse Pedal Pad	1
2	48-315	Foot Pedal Rod	2
	HN-516-24	Hex Nut, $\frac{5}{16}$ - 24	4
3	21-462	Ball Joint, $\frac{5}{16}$ - 24	6
	HWL-516	Lock Washer, $\frac{5}{16}$	6
	HN-516-24	Hex Nut, $\frac{5}{16}$ - 24	6
4	16-062	Pedal Pad Plate	1
	15-015	Pedal Pad	1
5	48-275	Engine Plate	1
6	HP-18-200	Cotter Pin, $\frac{1}{8}$ x 1	2
7	48-283	Idler Arm	1
	18-036	Bushing	1
	HG-14-28-180	Grease Fitting, $\frac{1}{4}$ - 28 x 180°	1
8	HMB-12-14	Machine Bushings, $\frac{1}{2}$ x 14GA	4
9	48-278	Pump Mount	1
10	HB-38-16-150	Hex Bolt, $\frac{3}{8}$ - 16 x $1\frac{1}{2}$	2
	HW-516	Flat Washer, $\frac{5}{16}$	2
	HNTL-38-16	Nylon Lock Nut, $\frac{3}{8}$ - 16	2
11	48-267	Hydro pump	1
12	48-268	Gear Pump	1
13	HB-38-24-150	Hex Bolt, $\frac{3}{8}$ - 24 x $1\frac{1}{2}$	1
	HW-38	Flat Washer, $\frac{3}{8}$	4
	HNTL-38-24	Nylon Lock Nut, $\frac{3}{8}$ - 24	1
14	21-212	Spring	1
15	13-060	Idler Pulley	1
16	48-282	Shift Arm	1
	HSSHS-14-20-025	Socket Set Screw, $\frac{1}{4}$ - 20 x $\frac{1}{4}$	1
17	42-537	Spade Hex Bolt	1
18	HNTL-38-16	Nylon Lock Nut, $\frac{3}{8}$ - 16	1
19	48-277	Linkage Rod	1
	HN-38-24	Hex Nut, $\frac{3}{8}$ - 24	2
20	48-276	Pedal Relay	1
21	48-314	Linkage Rod	1
	HN-516-24	Hex Nut, $\frac{5}{16}$ - 24	2
22	HB-14-20-100	Hex Bolt, $\frac{1}{4}$ -20 x 1	2
	HNTL-14-20	Nylon Lock Nut, $\frac{1}{4}$ -20	2
23	48-272	Pedal Pivot Arm	1
	HG-14-28-180	Grease Fitting, $\frac{1}{4}$ - 28 x 180°	1
24	HP-18-100	Cotter Pin, $\frac{1}{8}$ x 1	2
25	HMB-12-14	Machine Bushings, $\frac{1}{2}$ x 14GA	6
26	76-296	Pedal Mount	2
	18-234	Bushing	2
	HG-14-28-180	Grease Fitting, $\frac{1}{4}$ - 28 x 180°	2
27	HSTP-516-18-075	Truss Head Screw, $\frac{5}{16}$ - 18 x $\frac{3}{4}$	4
	HNFL-516-18	Flange Whiz-loc Nut, $\frac{5}{16}$ -18	4
28	48-311	Foot Pedal	2
29	HB-38-16-100	Hex Bolt, $\frac{3}{8}$ - 16 x 1	2
	HNTL-38-16	Nylon Lock Nut, $\frac{3}{8}$ - 16	2
30	21-173	Ball Joint, $\frac{3}{8}$ - 24	2
	HWL-38	Lock Washer, $\frac{3}{8}$	2
	HN-38-24	Hex Nut, $\frac{3}{8}$ - 24	2

SEAT AND CONSOLE DRAWING

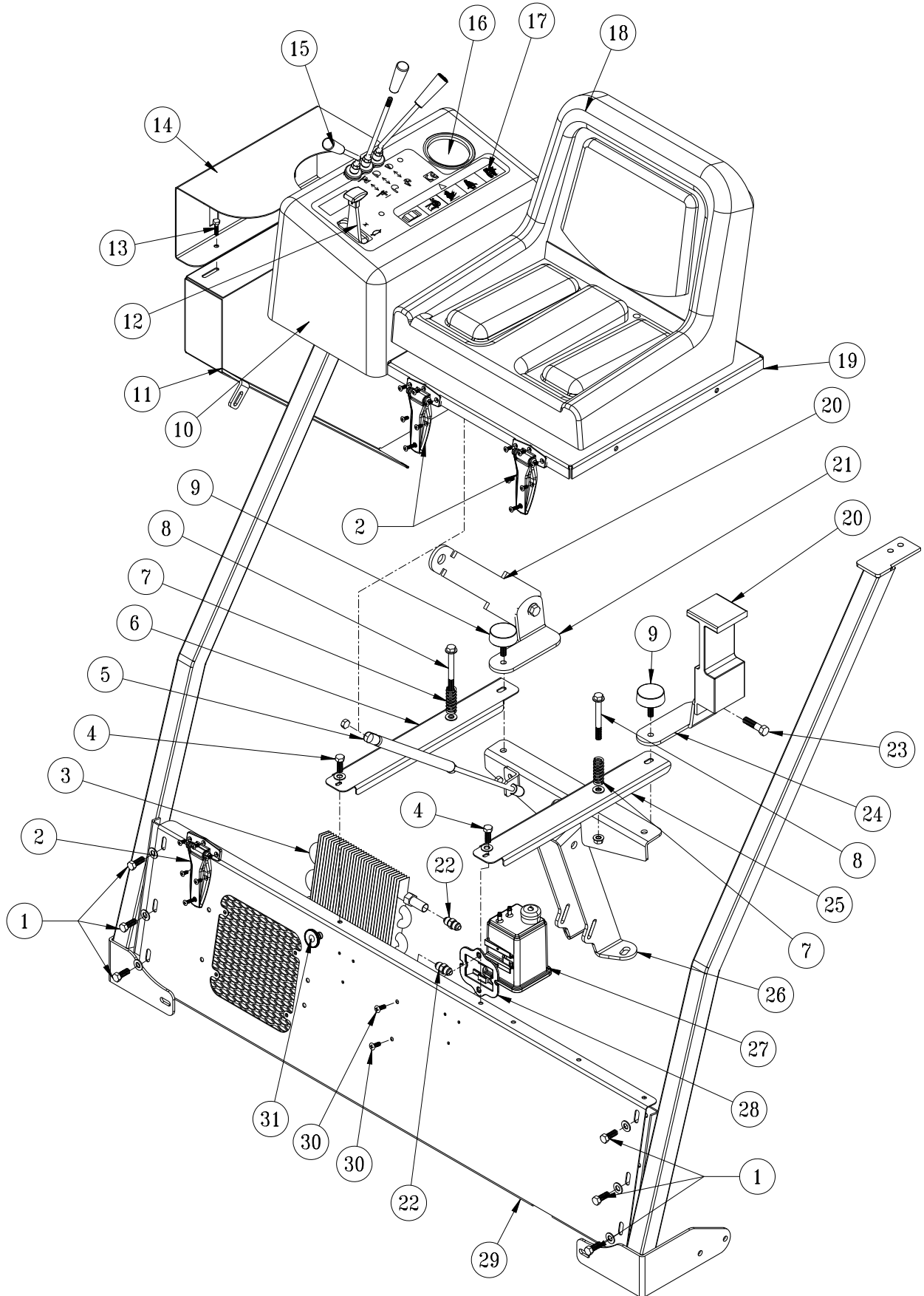

Parts

SEAT AND CONSOLE PARTS LIST

REF#	PART#	DESCRIPTION	QUANTITY
1	HB-38-16-100	Hex Bolt, $\frac{3}{8}$ - 16 x 1	6
	HW-38	Flat Washer, $\frac{3}{8}$	12
	HNFL-38-16	Flange Whiz-loc Nut, $\frac{3}{8}$ - 16	6
2	27-055	Flush Hinge	3
	HSMFCS-10-32-050	Machine Screw, #10 - 32 x $\frac{1}{2}$	15
	HSMFCS-10-32-100	Machine Screw, #10 - 32 x $\frac{1}{2}$	3
	HNFL-10-32	Flange Whiz-loc Nut, #10 -32	18
3	45-382	Oil Cooler	1
	18-410	Connector	1
4	HB-38-16-125	Hex Bolt, $\frac{3}{8}$ - 16 x $1\frac{1}{4}$	2
	HW-38	Flat Washer, $\frac{3}{8}$	2
	HNFL-38-16	Flange Whiz-loc Nut, $\frac{3}{8}$ - 16	2
5	8-563	Gas Spring	1
	26-034	Ball Stud	2
	HNFL-38-16	Flange Whiz-loc Nut, $\frac{3}{8}$ - 16	2
6	48-285	Right Seat Brace	1
7	11-055	Spring	2
8	HB-38-16-350	Hex Bolt, $\frac{3}{8}$ - 16 x $3\frac{1}{2}$	2
	HW-38	Flat Washer, $\frac{3}{8}$	4
	HNTL-38-16	Nylon Lock Nut, $\frac{3}{8}$ - 16	2
9	50-081	Rubber Insulator	2
	HNFL-38-16	Flange Whiz-loc Nut, $\frac{3}{8}$ - 16	2
10	48-262	Engine Cover	1
11	48-313	Belt Guard	1
12	48-271	Throttle Cable Assembly	1
	8-624	Knob	1
13	HB-516-18-100	Hex Bolt, $\frac{5}{16}$ -18 x 1	2
	HNFL-516-18	Flange Whiz-loc Nut, $\frac{5}{16}$ - 18	2
14	48-308	Heat Shield	1
15	78-417	Valve Handles	3
16	15-781	Drink Cup Holder	1
17	48-261	Decal, Control Panel	1
18	14-294	Seat Kit	1
	14-292	Seat Switch	1
	14-800	Seat Rail	2
	HSP-1260-340-250	Spacer	4
	HB-516-18-100	Hex Bolt, $\frac{5}{16}$ -18 x 1	4
19	48-290	Seat Panel	1
	HLC-A-58	Loom Clamp	1
20	76-198-03	Seat Belt	1
21	48-286	RH Seat Belt Bracket	1
22	18-410	Connector	2
23	HB-716-14-125	Hex Bolt, $\frac{7}{16}$ -14 x $1\frac{1}{4}$	2
	HW-716	Flat Washer, $\frac{7}{16}$	2
	HNTL-716-14	Nylon Lock Nut, $\frac{7}{16}$ -14	2
24	48-287	LH Seat Belt Bracket	1
25	48-284	Left Seat Brace	1
26	48-288	Seat Support	1
27	8-738	Carbon Canister	1
	8800-50	Fuel Line (purge line to engine)	1
	8800-26	Fuel Line (to gas tank)	1
	18-186	Hose Clamp	4
28	8-688	Mount Bracket	1
29	48-291	Front Panel	1
30	HSTP-14-20-075	Truss Head Screw, $\frac{1}{4}$ - 20 x $\frac{3}{4}$	2
	HNFL-14-20	Flange Whiz-loc Nut, $\frac{1}{4}$ -20	2
31	80-020	Choke Cable	1

FUEL AND OIL TANK DRAWING

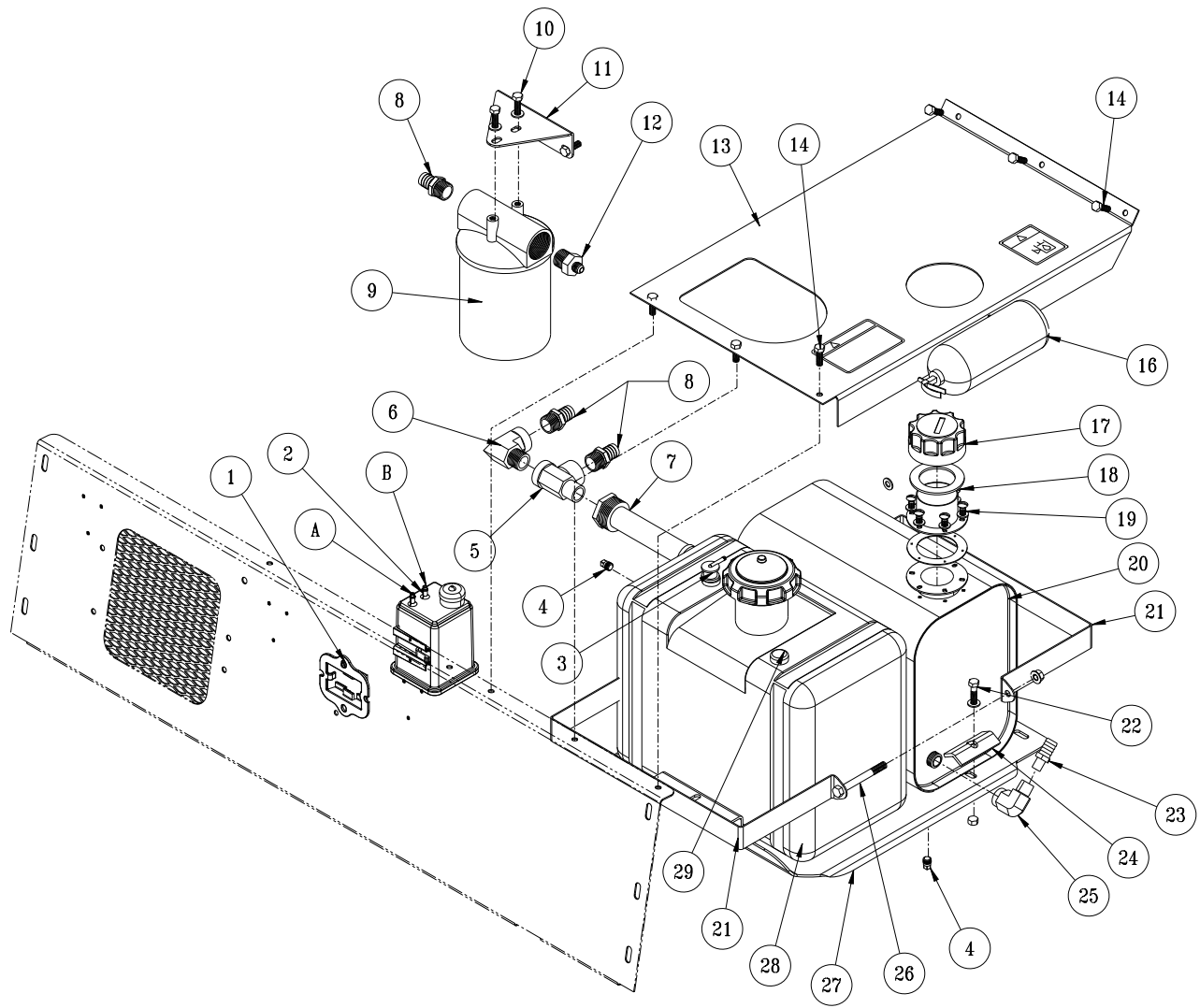

PARTS

Not Illustrated

A	8800-26	1/4" Fuel Line	1
	18-186	Hose Clamp	2
B	9025-32	3/16" Fuel Line	1
	18-186	Hose Clamp	2

FUEL AND OIL TANK PARTS LIST

REF#	PART#	DESCRIPTION	QUANTITY
1	8-688	Mount Bracket	1
2	8-738	Carbon Canister	1
3	*	Top Draw	1
	8800-50	1/4" Fuel Hose (tank to engine)	1
	8983-44	Fire Sleeve	1
	50-403	In-line Fuel Filter (replacement parts)	1
	18-116	Hose Clamp	2
4	18-118	Pipe Plug, 1/8 (part of tank)	2
5	18-093	Street Tee	1
6	18-140	Elbow	1
7	60-213	Strainer	1
8	18-249	Barb Fitting	3
9	20-576	Oil Filter	1
	20-576-01	Replacement Filter Only	1
10	HB-516-18-100	Hex Bolt, 5/16 - 18 x 1	2
	HW-516	Flat Washer, 5/16	2
	HWL-516	Lock Washer, 5/16	2
11	13-217	Filter Bracket	1
12	23-183	Male Connector	1
13	48-316	Side Cover	1
	25-307	Decal, Refuel w/ Gasoline	1
	27-093	Decal, Hydraulic Oil	1
	25-362	Decal, Danger Fire	1
	8803-24	Black Trim	1
	8803-16	Black Trim	1
14	HB-516-18-100	Hex Bolt, 5/16 - 18 -100	6
	HNFL-516-18	Flange Whiz-loc Nut, 5/16 - 18	6
16	76-354	Fire Extinguisher	1
	HSM-8-32-100	Machine Screw, #8 - 32 x 1	3
	HNFL-8-32	Flange Whiz-loc Nut, #8 - 32	3
17	13-747	Filler Breather	1
	13-586-01	Cap Gasket	1
18	13-586-03	Neck	1
	13-586-02	Bottom Gasket	1
19	HSM-10-32-063	Machine Screw #10 - 32 x 5/8	6
	HWL-10	Lock Washer #10	6
20	60-473	Oil Tank	1
21	48-281	Tank Strap	2
22	HB-516-18-150	Hex Bolt, 5/16 - 18 x 1 1/2	2
	HW-516	Flat Washer, 5/16	2
	HNTL-516-18	Nylon Lock Nut 5/16 - 18	2
23	18-133	Hose Barb	1
24	75-792	Tank Hold-down	2
25	18-009	90° Street Elbow	1
26	HB-516-18-300	Hex Bolt 5/16 - 18 - x 3	2
	HNTL-516-18	Nylon Lock Nut 5/16 - 18	2
27	48-280	Tank Plate	1
28	15-838	CARB Gas Tank (includes all * items)	1
	*73-050	Cap	
29	*	Dial Fuel Level Gauge	1

HOPPER LIFT CYLINDER

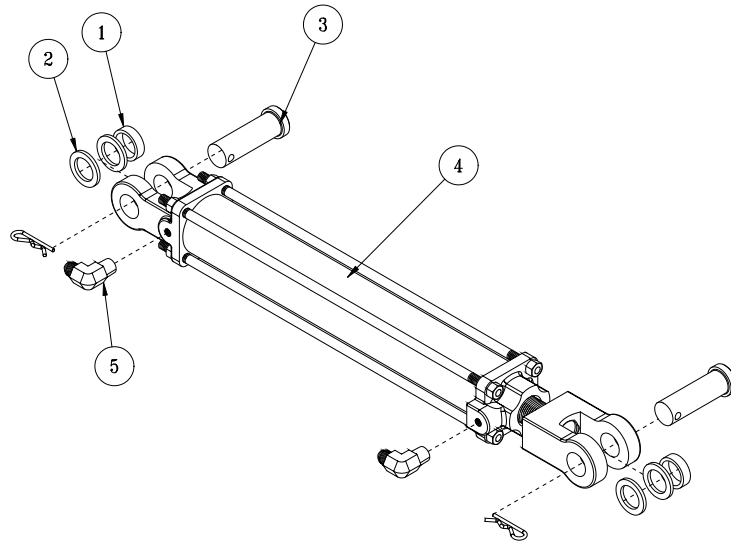

REEL LIFT CYLINDER

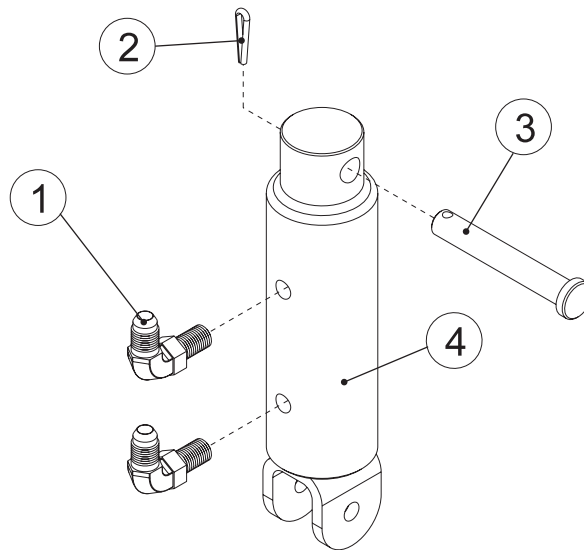

TAILGATE CYLINDER

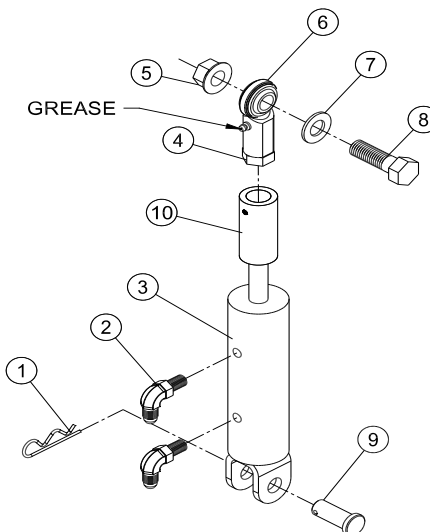

HOPPER LIFT CYLINDER

REF#	PART#	DESCRIPTION	QUANTITY
1	48-129	Spacer (inside of clevis to outside of machine)	4
2	HMB-100-10	Machine Bushing 1 x 10GA (inside clevis; inside machine)	8
3	HCP-100-325	Clevis Pin, 1 x 3¼	4
	HHP-.177	Bridge Pin	4
4	76-627	Hydraulic Cylinder	2
	76-242-01	Seal Kit	1 per
5	23-167	Elbow	4

REEL LIFT CYLINDER

REF#	PART#	DESCRIPTION	QUANTITY
1	18-168	Elbow	2
2	HP-18-100	Cotter Pin, 1/8 x 1	1
3	HCP-12-350	Clevis Pin, 1/2 x 3 1/2	1
4	76-478	Hydraulic Cylinder	1
	14-531	Seal Kit	1

TAILGATE CYLINDER

REF#	PART#	DESCRIPTION	QUANTITY
1	HHP-.177	Bridge Pin	1
2	18-168	Elbow	2
3	10-554	Hydraulic Cylinder	1
	14-531	Seal Kit	1
4	HNJ-58-18	Jam Nut, 5/8 - 18	1
5	HNCL -58-11	Center Nylon Lock Nut, 5/8 - 11	1
6	18-154	Rod End	1
	HG-14-28-180	Grease Fitting, 1/4 - 28 x 180°	1
7	HMB-58-14	Machine Bushing, 5/8 - 14GA	3
8	HB-58-11-200	Hex Bolt, 5/8 - 11 x 2	1
9	HCP-58-150	Clevis Pin, 5/8 x 1 1/2	1
10	48-328	Cylinder Stop	1

ENGINE AND EXHAUST DRAWING

PARTS

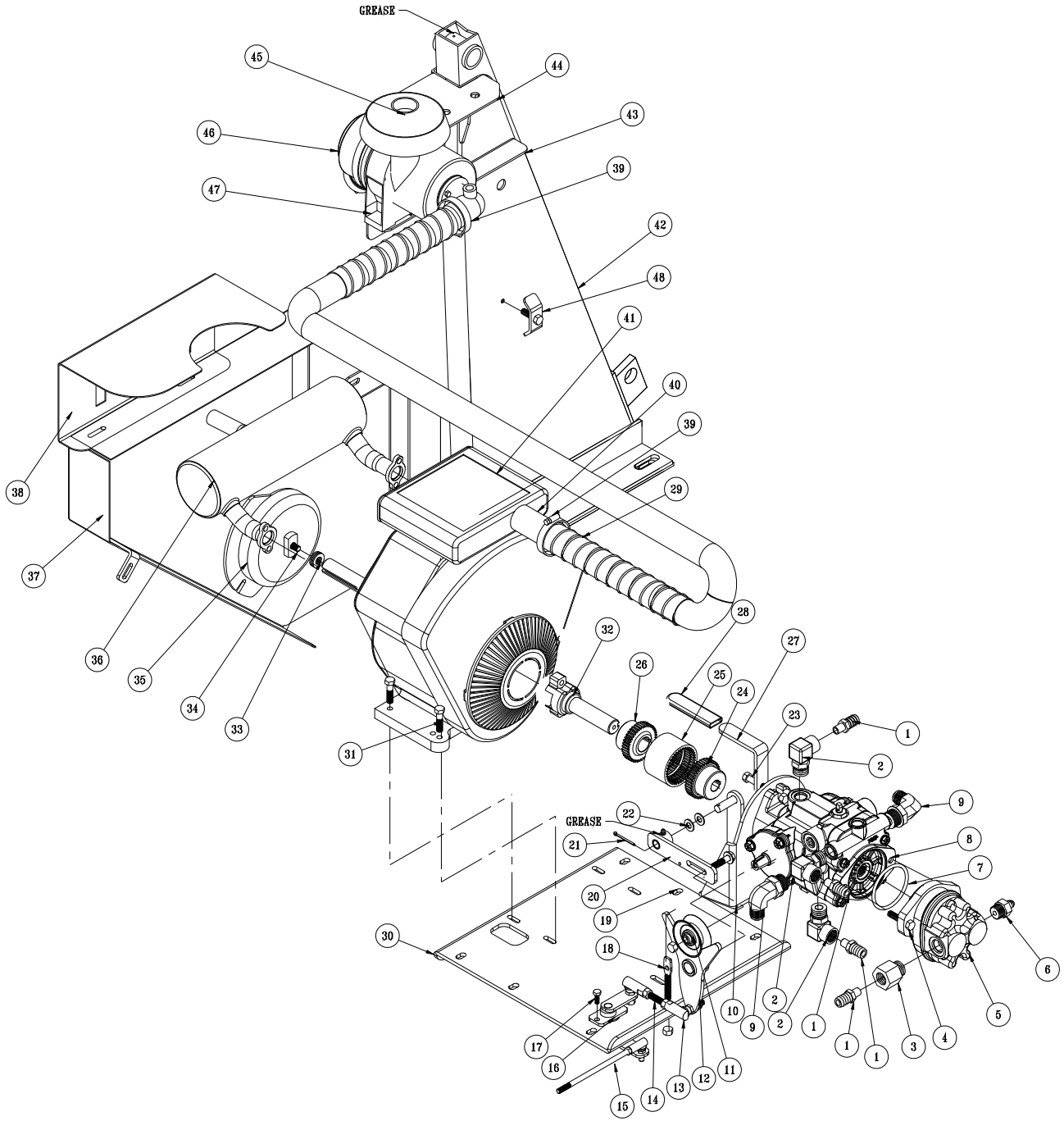

ENGINE AND EXHAUST PARTS LIST

REF#	PART#	DESCRIPTION	QUANTITY
1	18-133	Hose Barb	4
2	23-130	90° Straight Elbow	3
3	23-136	Female Adapter	1
4	HB-38-16-125	Hex Bolt, $\frac{3}{8}$ -16 x $1\frac{1}{4}$	2
	HNFL-38-16	Flange Whiz-loc Nut, $\frac{3}{8}$ - 16	2
5	48-266	Gear Pump	1
6	18-331	Straight Thread Connector	1
7	23-145	O-ring	1
8	48-267	Hydro Pump	1
9	18-204	Straight Thread Elbow	2
10	48-278	Pump Mount	1
	HB-38-16-150	Hex Bolt, $\frac{3}{8}$ - 16 x $1\frac{1}{2}$	2
	HW-38	Flat Washer, $\frac{3}{8}$	2
	HNTL-38-16	Nylon Lock Nut, $\frac{3}{8}$ - 16	2
11	13-060	Idler Pulley	1
	HB-38-24-150	Hex Bolt, $\frac{3}{8}$ - 24 x $1\frac{1}{2}$	1
	HW-38	Flat Washer, $\frac{3}{8}$	4
	HNTL-38-24	Nylon Lock Nut, $\frac{3}{8}$ - 24	1
14	21-212	Spring	1
15	13-060	Idler Pulley	1
12	48-282	Shift Arm	1
	HSSHS-14-20-025	Socket Set Screw, $\frac{1}{4}$ - 20 x $\frac{1}{4}$	1
13	21-173	Ball Joint, $\frac{3}{8}$ - 24	2
	HWL-38	Lock Washer, $\frac{3}{8}$	2
	HN-38-24	Hex Nut, $\frac{3}{8}$ - 24	2
14	48-277	$\frac{3}{8}$ " Linkage Rod	1
	HN-38-24	Nut $\frac{3}{8}$ - 24	2
15	48-314	$\frac{5}{16}$ " Linkage Rod	1
	HN-516-24	Hex Nut, $\frac{5}{16}$ - 24	4
	21-462	Ball Joint, $\frac{5}{16}$ - 24	2
	HWL-516	Lock Washer, $\frac{5}{16}$	2
16	48-276	Pedal Relay	1
17	HB-14-20-100	Hex Bolt, $\frac{1}{4}$ -20 x 1	2
	HNTL-14-20	Nylon Lock Nut, $\frac{1}{4}$ -20	2
18	42-537	Spade Hex Bolt	1
19	21-212	Spring	1
20	48-283	Idler Arm	1
	18-036	Bushing	1
	HG-14-28-180	Grease Fitting, $\frac{1}{4}$ - 28 x 180°	1
21	HP-18-200	Cotter Pin, $\frac{1}{8}$ x 1	1
22	HMB-12-14	Machine Bushings, $\frac{1}{2}$ x 14GA	4
23	HB-38-16-150	Hex Bolt, $\frac{3}{8}$ - 16 x $1\frac{1}{2}$	1
	HB-38-16-175	Hex Bolt, $\frac{3}{8}$ - 16 x $1\frac{3}{4}$	1
	HW-516	Flat Washer, $\frac{5}{16}$	2
	HNTL-38-16	Nylon Lock Nut, $\frac{3}{8}$ - 16	2
24	48-269	Coupler Half, $\frac{7}{8}$ " Bore	1
	HSSHS-516-18-038	Socket Head Set Screw, $\frac{5}{16}$ - 18 x $\frac{3}{8}$	1
25	43-098	Steel Coupler Insert, #4	1
26	43-099	Splined Steel Coupler Half #4, 1" Bore	1
	HSSHS-516-18-038	Socket Head Set Screw, $\frac{5}{16}$ - 18 x $\frac{3}{8}$	1

(Continued on next page)

ENGINE AND EXHAUST DRAWING

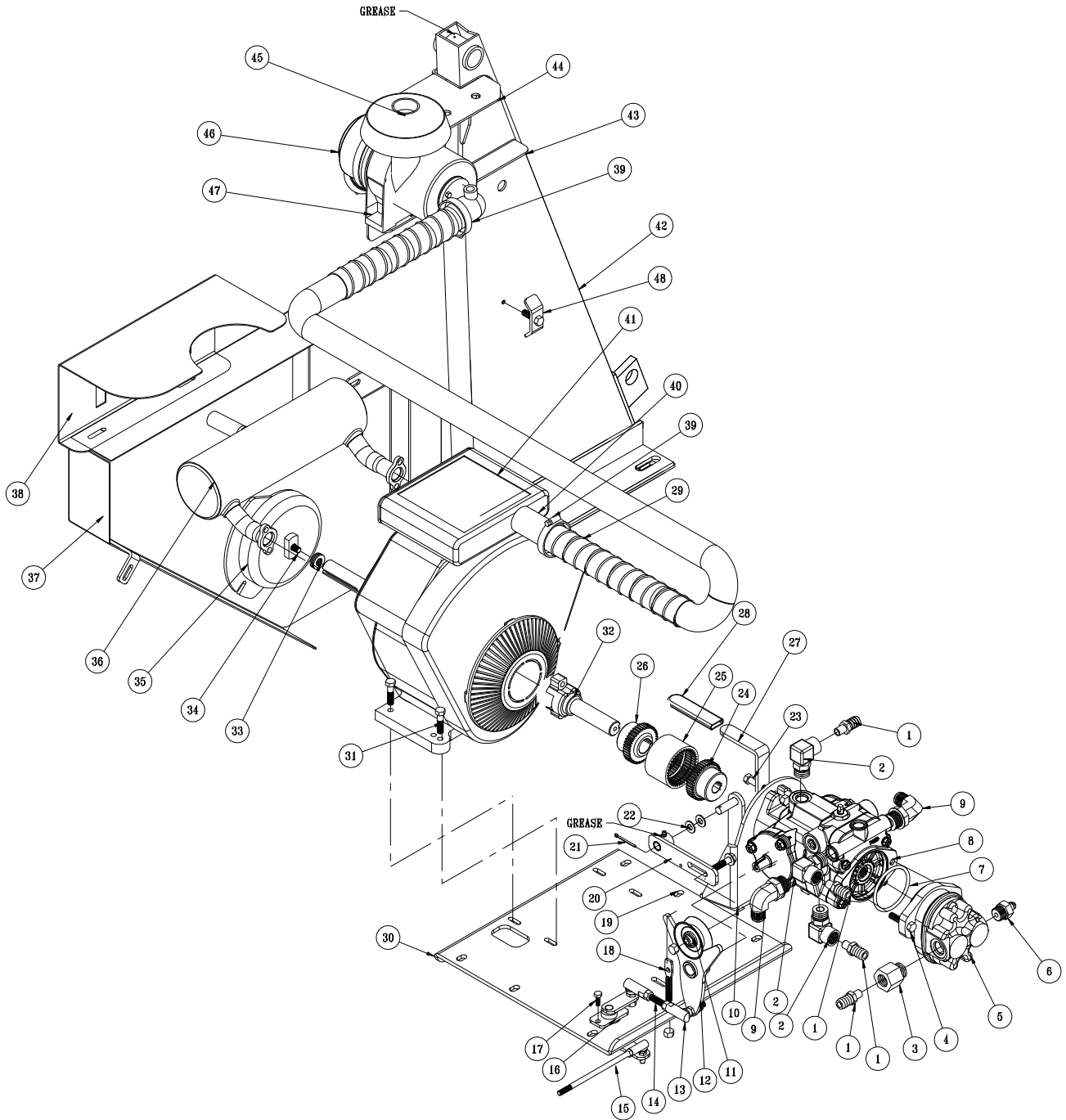

ENGINE AND EXHAUST PARTS LIST

REF#	PART#	DESCRIPTION	QUANTITY
27	48-279	Guard Strap	1
28	15-020	Hand Grip	1
29	8959-28	Flex Hose, 28"	1
30	48-275	Engine Plate	1
31	HB-516-18-175	Hex Bolt, $\frac{5}{16}$ - 18 x $1\frac{3}{4}$	4
	HNTL-516-18	Nylon Lock Nut, $\frac{5}{16}$ - 18	4
32	48-270	Stub Shaft	1
33	HMB-100-10	Machine Bushing, 1 x 10GA	4
34	HB-38-16-200	Hex Bolt, $\frac{3}{8}$ - 16 x 2	1
35	76-337	Electric Clutch	1
	17-271	Lead Wire for Clutch	1
36	45-158	Muffler	1
37	48-313	Belt Guard	1
38	48-308	Heat Shield	1
39	18-116	Hose Clamp	2
40	42-776	Air Cleaner Hose Sleeve	1
41	43-024	Engine, Briggs & Stratton 18HP	1
42	48-008	Right Tower	1
43	48-318	Air Cleaner Mount	1
	8803-5	Black Trim	1
44	48-206	Right Hand Mount	1
45	42-834-02	Hood	1
46	42-834	Air Cleaner	1
	42-076-03	Replacement Filter	
	13-603	Air Cleaner Base (comes with engine)	1
47	42-834-01	Band	1
48	13-099	Hose Clamp	1
	HB-516-18-125	Hex Bolt, $\frac{5}{16}$ -18 x $1\frac{1}{4}$	1
	HNFL-516-18	Flange Whiz-loc Nut, $\frac{5}{16}$ -18	1

Parts

Cyclonic air cleaner 42-834

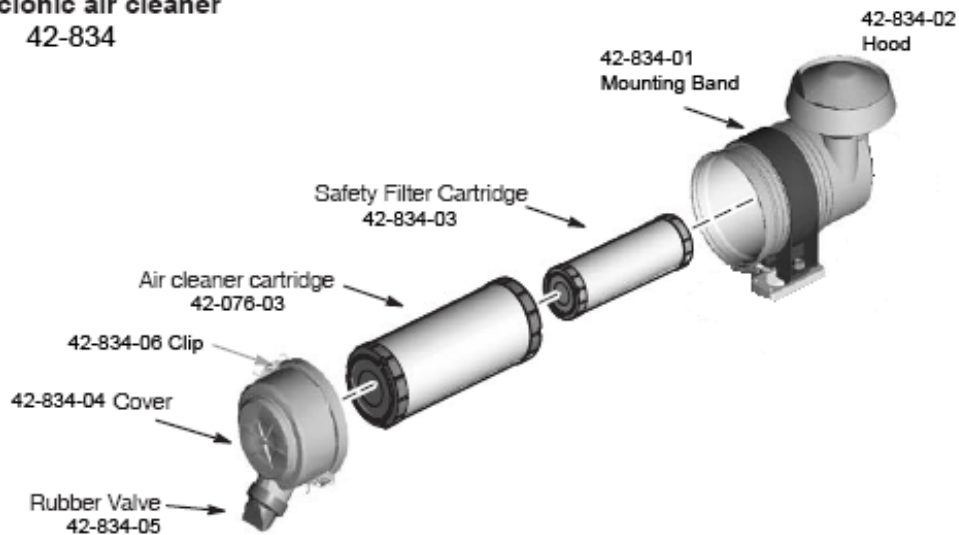

ELECTRIC CLUTCH DRIVEN BELT DRIVE & MUFFLER DRAWING

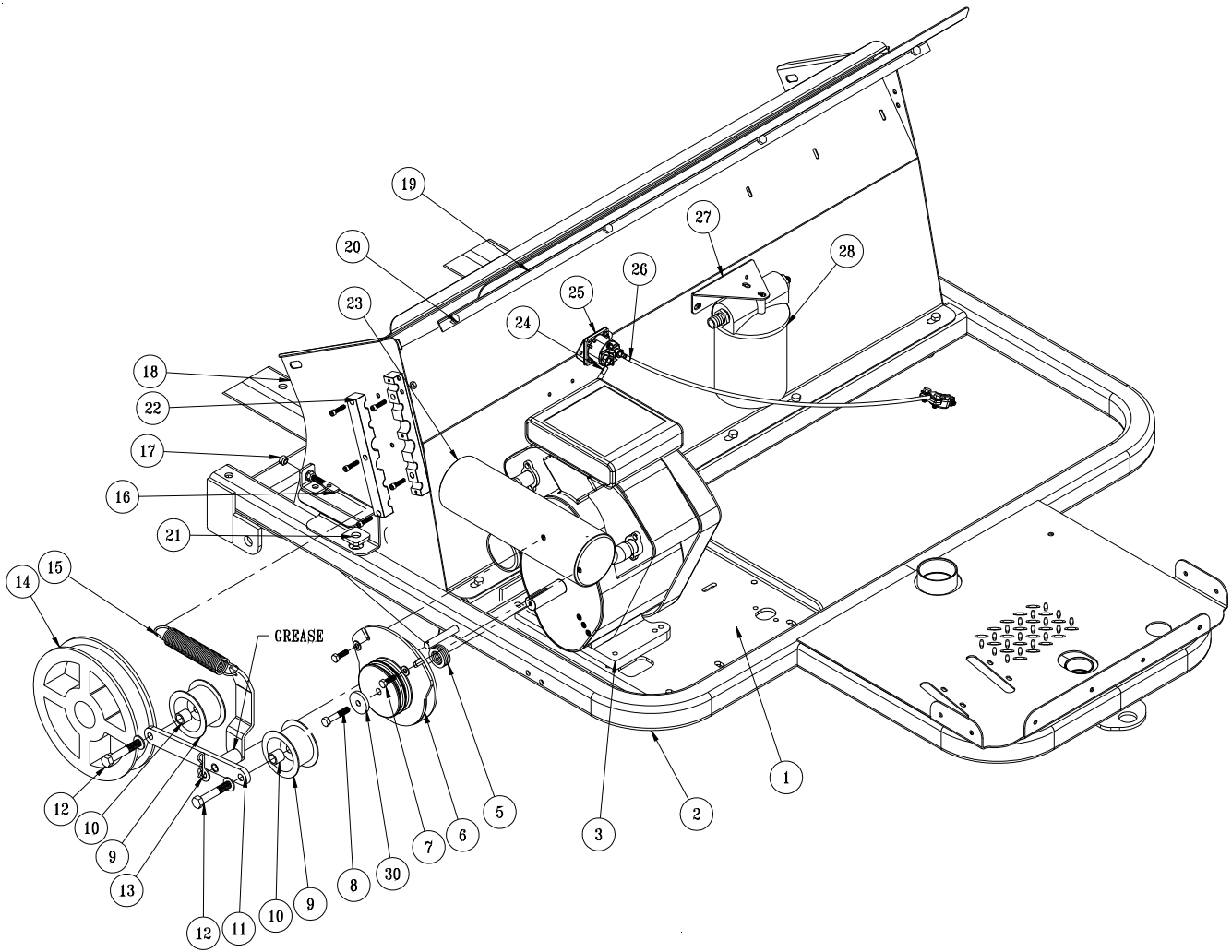

PARTS

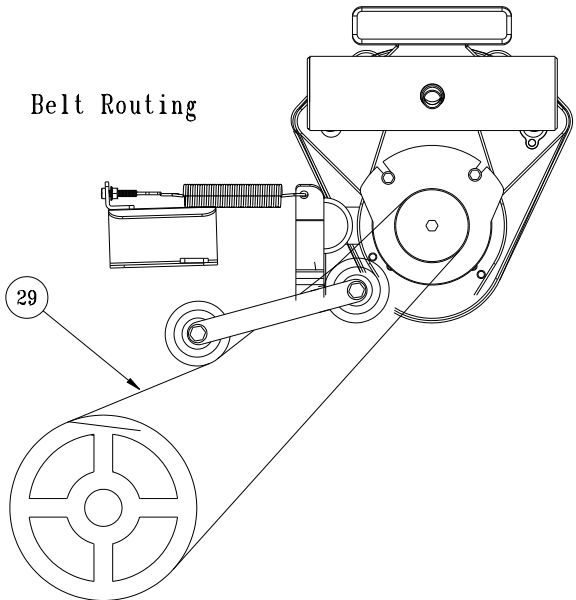

ELECTRIC CLUTCH DRIVEN BELT DRIVE & MUFFLER PARTS LIST

REF#	PART#	DESCRIPTION	QUANTITY
1	48-275	Engine Plate	1
2	48-300	Main Frame	1
3	43-024	Engine, Briggs & Stratton 18HP	1
5	HMB-100-10	Machine Bushing 1 x 10GA	4
6	76-337	Electric Clutch	1
	17-271	Lead Wire for Clutch	1
7	HB-38-16-125	Hex Bolt, $\frac{3}{8}$ - 16 x $1\frac{1}{4}$	2
	HWL-38	Lock Washer, $\frac{3}{8}$	2
8	HB-38-24-150	Hex Bolt, $\frac{3}{8}$ - 24 x $1\frac{1}{2}$	1
9	16-013	Idler Pulley	2
10	76-298	Spacer	2
11	48-273	Belt Tensioner	1
12	HB-12-13-350	Hex Bolt, $\frac{1}{2}$ - 13 x $3\frac{1}{2}$	2
	HNTL-12-13	Nylon Lock Nut, $\frac{1}{2}$ - 13	2
13	HMB-12-14	Machine Bushing, $\frac{1}{2}$ x 14GA	5
	HP-18-150	Cotter Pin, $\frac{1}{8}$ x $1\frac{1}{2}$	1
14	76-102	Pulley	1
	76-102-01	Hub, $1\frac{1}{4}$ ID	1
	HKSQ-14-150	Machine Key, $\frac{1}{4}$ x $\frac{1}{4}$ x $1\frac{1}{2}$	1
15	21-445	Spring	1
16	42-537	Spade Hex Bolt	1
17	HNFL-38-16	Flange Whiz-loc Nut, $\frac{3}{8}$ -16	2
18	48-307	Grass Chute	1
	8803-47	Black Trim	1
	8947-48	Trim Seal	1
	8828-14	Foam Tape	2
19	48-289	Rear Debris Guard	1
20	HB-516-18-100	Hex Bolt, $\frac{5}{16}$ - 18 x 1	4
	HW-516	Flat Washer, $\frac{5}{16}$	4
	HNTL-516-18	Nylon Lock Nut, $\frac{5}{16}$ - 18	4
21	76-151	Washer	4
22	76-336	Hose Clamp w/ Hardware	1
23	42-600	Muffler	1
24	22-065	Starter Cable - Black	1
25	13-750	Solenoid w/ Connector	1
26	78-325	Battery Cable - red	1
27	13-217	Oil Filter Mount	1
28	20-576	Oil Filter	1
	20-576-01	Replacement Filter	
29	48-259	Belt	1
30	78-370	Spacer	1

FINGER / BRUSH REEL DRAWING

PARTS

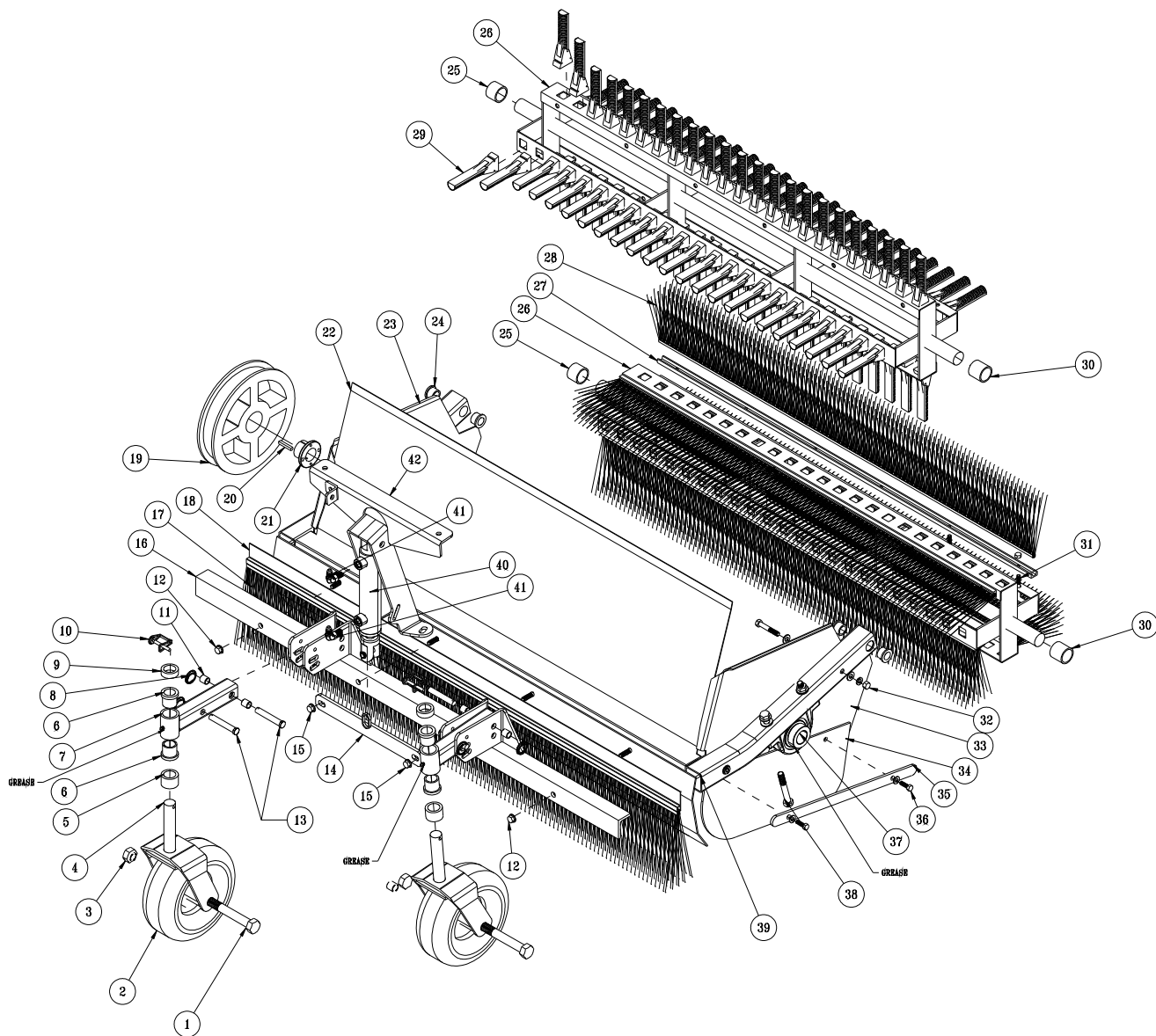

FINGER / BRUSH REEL PARTS LIST

REF#	PART#	DESCRIPTION	QUANTITY
1	HB-34-10-550	Hex Bolt, $\frac{3}{4}$ - 10 x 5 $\frac{1}{2}$	2
2	33-435	Tire and Wheel	2
	33-435-02	Wheel with Roller Bearing	
	33-435-03	Roller Bearing	
	33-435-04	Bushing	
3	HNTL-34-10	Nut $\frac{3}{4}$ - 10	2
4	48-046	Castor Fork	2
5	29-585	Spacer Height Adjustment 1"	2
6	18-223	Bushing (part of 77-171)	4
7	77-171	Arm	2
	HG-14-28-180	Grease Fitting, $\frac{1}{4}$ - 28 x 180°	1
8	76-483	Kickout Ring	4
9	29-584	Spacer Adjustment, $\frac{1}{4}$ "	2
10	29-541	Lock Pin	2
11	20-019	Bushing (part of 77-171)	4
12	HB-38-16-350	Hex Bolt, $\frac{3}{8}$ - 16 x 3 $\frac{1}{2}$	2
	HW-38	Flat Washer, $\frac{3}{8}$	4
	HNTL-38-16	Nylon Lock Nut, $\frac{3}{8}$ - 16	2
13	HCP-12-225	Clevis Pin, $\frac{1}{2}$ - 2 $\frac{1}{4}$	4
14	48-048	Beater Chain Bracket	1
15	HB-38-16-400	Hex Bolt, $\frac{3}{8}$ - 16 x 4	2
	HW-38	Washer, $\frac{3}{8}$	4
	HNTL-38-16	Nylon Lock Nut, $\frac{3}{8}$ - 16	2
16	48-045	Castor Frame	1
17	48-221	Brush	1
18	48-222	Brush Channel	1
19	76-102	Pulley with Hub	1
20	HKSQ-14-150	Square Key, $\frac{1}{4}$ x 1 $\frac{1}{2}$	1
21	76-102-01	Hub, 1 $\frac{1}{4}$ ID	1
22	48-028	Front Baffle	1
23	75-799	Right Side Plate	1
24	18-221	Flange Bushing (part of 48-030)	4
25	75-834	Spacer (right)	1
26	48-323	Reel	1
27	48-105	Clamp	4
28	48-086	Brush	4
29	75-506	Sweeper Finger	96
30	75-686	Spacer (left)	1
31	HB-516-18-125	Hex Bolt, $\frac{5}{16}$ - 18 x 1 $\frac{1}{4}$	24
	HNTL-516-18	Nylon Lock Nut, $\frac{5}{16}$ - 18	24
32	HB-38-16-275	Hex Bolt, $\frac{3}{8}$ - 16 x 2 $\frac{3}{4}$	4
	HN-38-16	Hex Nut, $\frac{3}{8}$ - 16	4
	HWL-38	Lock Washer, $\frac{3}{8}$	4
	HW-38	Flat Washer, $\frac{3}{8}$	8
33	75-800	Left Side Plate	1
34	76-210	Matting	2
35	76-213	Reel Guard Strap	2
36	HB-516-18-100	Hex Bolt, $\frac{5}{16}$ - 18 x 1	4
	HW-516	Flat Washer, $\frac{5}{16}$	4
	HWL-516	Lock Washer, $\frac{5}{16}$	4
	HN-516-18	Hex Nut, $\frac{5}{16}$ - 18	4
37	75-511	Pillow Block	2
38	HB-12-13-350	Hex Bolt, $\frac{1}{2}$ - 13 x 3 $\frac{1}{2}$	4
	HW-716	Flat Washer, $\frac{7}{16}$	4
	HNTL -12-13	Nylon Lock Nut, $\frac{1}{2}$ - 13	4
39	48-030	Beater Frame	1
40	76-478	Hydraulic Cylinder	1
	14-531	Seal Kit	1
	HP-18-100	Cotter Pin, $\frac{1}{8}$ x 1	1
	HCP-12-350	Clevis Pin, $\frac{1}{2}$ x 3 $\frac{1}{2}$	1
41	18-168	Elbow	2
42	48-288	Seat Support	1

REAR AXLE DRAWING

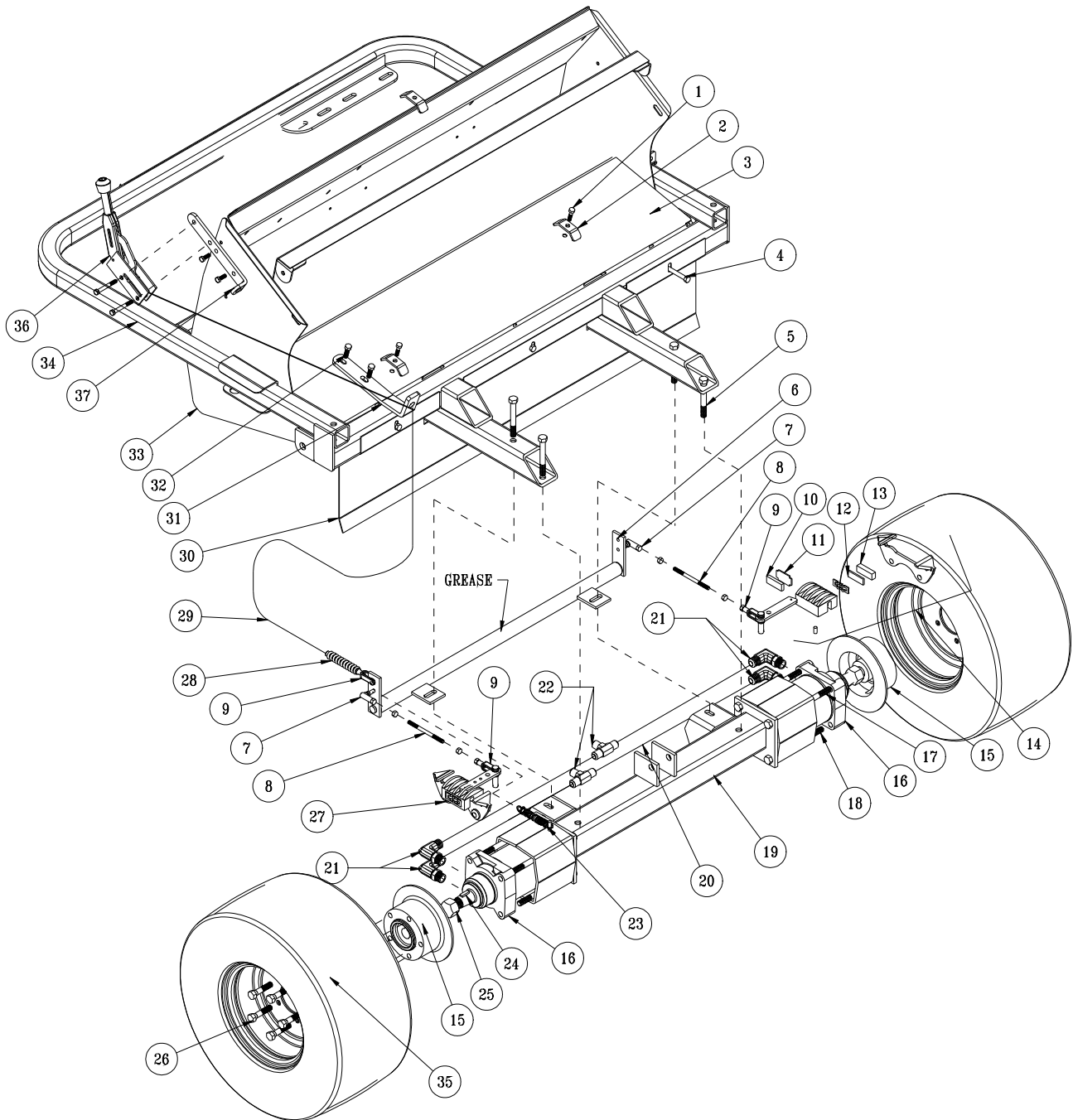

PARTS

REAR AXLE PARTS LIST

REF#	PART#	DESCRIPTION	QUANTITY
1	HB-516-18-125	Hex Bolt, $\frac{5}{16}$ - 18 x $1\frac{1}{4}$	2
	HWL-516	Lock Washer, $\frac{5}{16}$	2
2	13-099	Clamp	2
3	48-305	Rear Baffle	1
4	HB-38-16-350	Hex Bolt, $\frac{3}{8}$ - 16 x $3\frac{1}{2}$	5
	HW-38	Flat Washer, $\frac{3}{8}$	5
	HNTL-38-16	Nylon Lock Nut, $\frac{3}{8}$ - 16	5
5	HB-12-13-400	Hex Bolt, $\frac{1}{2}$ - 13 x 4	4
	HW-716	Flat Washer, $\frac{7}{16}$	2
	HNTL-12-13	Nylon Lock Nut, $\frac{1}{2}$ - 13	4
6	48-055	Brake Relay	1
7	21-462	Ball Joint, $\frac{5}{16}$ - 24	2
8	76-300	Brake Rod	2
	HN-516-24	Hex Nut, $\frac{5}{16}$ - 24	4
9	11-100	Linkage Yoke, $\frac{5}{16}$	3
	HCP-516-100	Clevis Pin, $\frac{5}{16}$ x 1	3
	HP-18-075	Cotter Pin, $\frac{1}{8}$ x $\frac{3}{4}$	3
10*		Carrier Side Pad	1
11*		Carrier Side Pad Support	1
12*		Cam Side Pad support	1
13*		Cam Side Pad	1
14	76-241	Right Caliper	1
15	76-239	Brake Disc	2
16	76-238	Wheel Motor	2
17	HB-12-13-800	Hex Bolt, $\frac{1}{2}$ - 13 x 8	4
	HNTL-12-13	Nylon Lock Nut, $\frac{1}{2}$ - 13	4
	HMB-12-14	Machine Bushing, $\frac{1}{2}$ x 14GA	4
18	HB-12-13-750	Hex Bolt, $\frac{1}{2}$ - 13 x $7\frac{1}{2}$	4
	HNTL-12-13	Nylon Lock Nut, $\frac{1}{2}$ - 13	4
19	48-031	Rear Axle	1
20	48-244	Hydraulic Tube	4
21	34-122	Short Elbow	4
22	34-057	Tee	2
23	29-118	Zinc Plate Spring	1
24	HWK-516-100	Woodruff Key $\frac{5}{16}$ x 1 (comes with wheel motor)	2
25	14-265	Nut 1 - 20 (comes with wheel motor)	2
26	60-268	Lug Hex Bolt $\frac{1}{2}$ - 20 x $1\frac{5}{16}$	10
27	76-240	Left Caliper	1
28	60-536	Bellows	1
29	34-029	Brake Cable	1
30	48-006	Rear Beater Panel	1
31	48-134	Brake Cable Bracket	1
32	HB-38-16-125	Hex Bolt, $\frac{3}{8}$ - 16 x $1\frac{1}{4}$	2
	HW-38	Flat Washer, $\frac{3}{8}$	4
	HNTL-38-16	Nylon Lock Nut, $\frac{3}{8}$ - 16	2
33	48-307	Grass Chute	1
	8947-48	Trim Seal	2
34	48-300	Main Frame	1
35	48-265	Tire and Wheel	2
	43-123-01	Tire, 22 x 11 x 10 Turf Master	2
	16-857-02	Wheel	2
36	60-106	Brake Lever	1
37	48-324	Park Brake Handle Mount	1
	HB-516-18-225	Hex Bolt, $\frac{5}{16}$ -18 x $2\frac{1}{4}$	2
	HNFL-516-18	Flange Whiz-loc Nut, $\frac{5}{16}$ -18	2
*	34-101-02	Pad Kit with 2 Pads and Steel Support Plates	2 Kits per Axle

HOPPER AND TAILGATE DRAWING

- 48-501 Hopper Dust Shield
- 48-326 Hopper Filter 20" x 45"
- 48-325 Tailgate Filter 17" x 46"

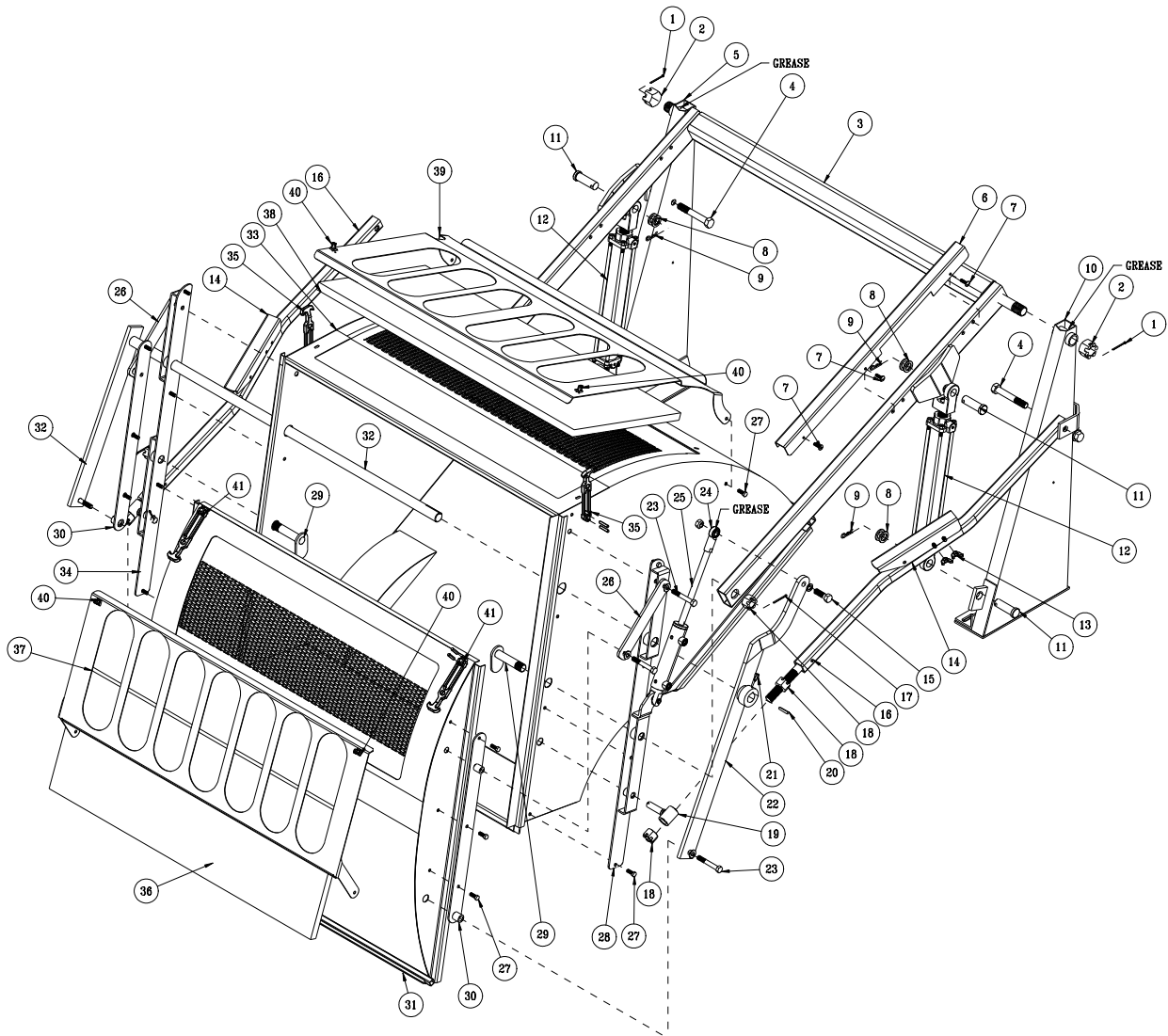
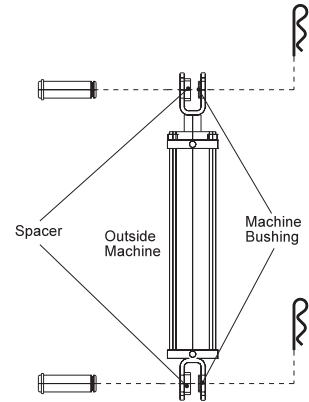

PARTS

HOPPER AND TAILGATE PARTS LIST

REF#	PART#	DESCRIPTION	QUANTITY
1	HP-18-200	Cotter Pin, 1/8 x 2	2
2	HNA-114-12	Axle Nut, 1 1/4 - 12	2
3	48-297	Pivot Arm	1
4	HB-34-10-500	Hex Bolt, 3/4 - 10 x 5	2
	HNTL-34-10	Nylon Lock Nut, 3/4 - 10	2
5	48-009	LH Tower	1
6	48-296	Hose Guard	1
7	HSSHS -516-18-075	Socket Head Set Screws, 5/16 - 18 x 3/4	3
	HNFL-516-18	Flange Whiz-loc Nut, 5/16 - 18	3
8	HMB-100-10	Machine Bushing, 1 x 10GA (inside clevis; inside machine)	8
9	HHP-.177	Bridge Pin	4
10	48-008	RH Tower	1
11	HCP-100-325	Clevis Pin, 1 x 3 1/4	4
	48-129	Spacer (inside of clevis to outside of machine)	4
12	76-627	Hydraulic Cylinder	2
	76-242-01	Seal Kit	
13	HB-38-16-225	Hex Bolt, 3/8 - 16 x 2 1/4	4
	HNW-38-16	Wing Nut, 3/8 - 16	4
14	75-653	Hopper Safety Lift	2
	75-651	Decal, Hopper Lift Safety Bar	2
15	HB-58-11-250	Hex Bolt, 5/8 - 11 x 2 1/2	2
	HMB-58-14	Machine Bushing, 5/8 x 14GA	2
	HNTL-58-11	Nylon Lock Nut, 5/8 - 11	2
16	48-299	Dump Arm	2
17	HP-18-150	Cotter Pin, 1/8 x 1 1/2	2
18	HNA-100-14	Castle Nut, 1 - 14	4
19	75-632	Adjustment Sleeve	2
	HP-18-100	Cotter Pin, 1/8 x 1	2
20	HKSQ-14-150	Machine Key, 1/4 x 1/4 x 1 1/2	1
21	HSSHS-516-18-038	Socket Set Screw 5/16 - 18 x 3/8	1
22	48-302	RH Dump Arm	1
23	HB-12-13-300	Hex Bolt, 1/2 - 13 x 3	6
	HNTL-12-13	Nylon Lock Nut, 1/2 - 13	6
24	18-154	Rod End	1
25	10-554	Hydraulic Cylinder	1
	14-529	Seal Kit	
	HCP-58-150	Clevis Pin, 5/8 x 1 1/2	1
	HHP-.177	Bridge Pin	1
26	48-298	Hinge Strap	2
27	HB-38-16-100	Hex Bolt, 3/8 - 16 x 1	12
	HNTL-38-16	Nylon Lock Nut, 3/8 - 16	12
28	48-304	RH Hopper Hinge Strap	1
29	75-569	Swivel Bottom	2
30	48-303	Tailgate Hinge Strap	2
31	48-310	Tailgate	1
32	48-301	LH Dump Arm	1
33	48-309	Hopper	1
34	48-306	LH Hopper Hinge Strap	1
35	15-437	Latch and Keeper Complete	2
	15-437-02	Latch and Bracket only	2
	HRS-316-1125	Rivet	4
	HRW-316	Rivet Washer	6
36	48-325	Tailgate Filter	1
37	48-321	Dust Cover	1
38	48-326	Hopper Filter	1
39	48-322	Top Filter Cover	1
40	15-437-01	Keeper only	4
41	78-384	Latch	2
	HRS-316-1125	Rivet	4
	HRW-316	Rivet Washer, 5/16	4
	HW-316	Flat Washer, 5/16	2

48-267 HYDROSTATIC PUMP DRAWING

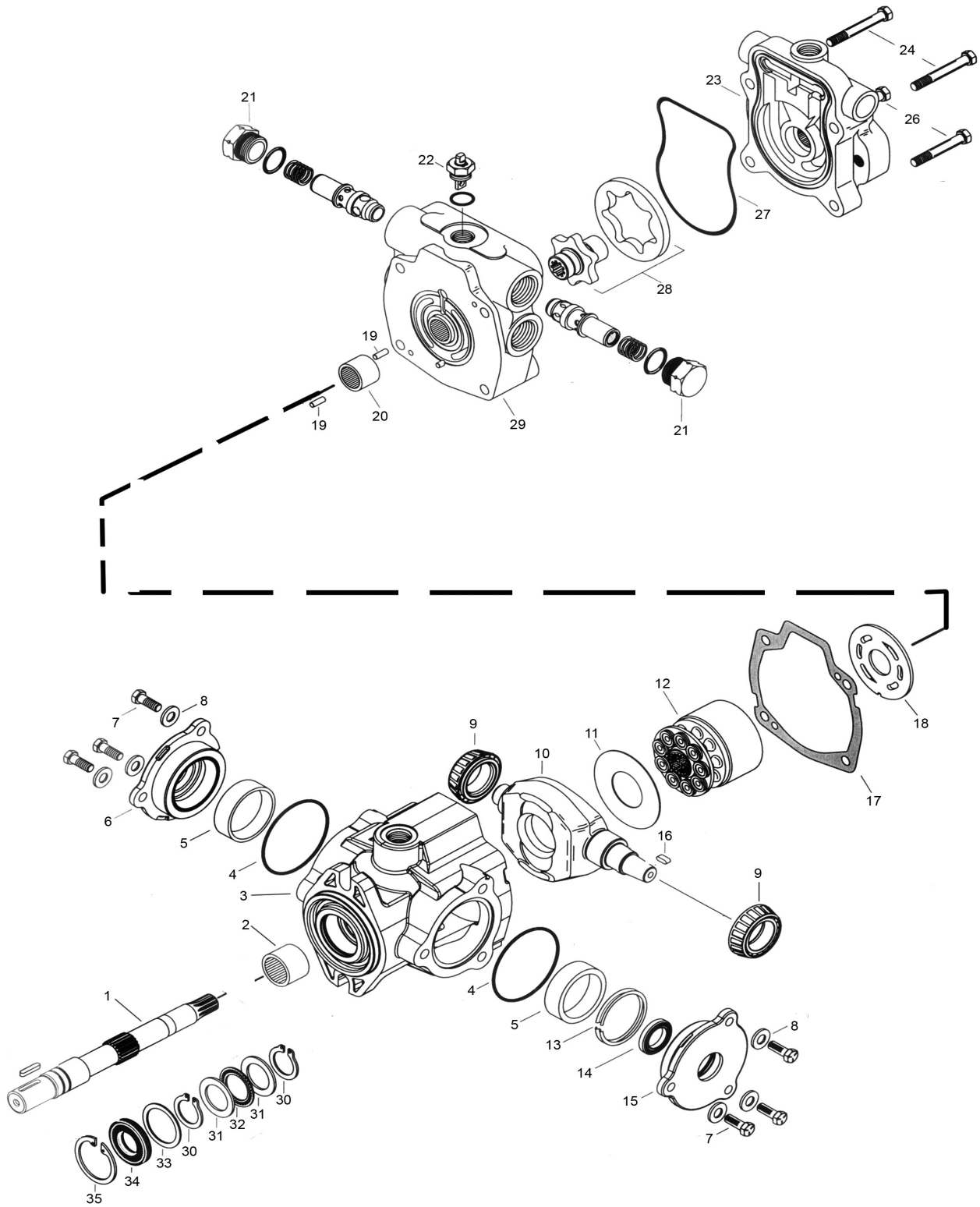

Parts

48-267 HYDROSTATIC PUMP PARTS LIST

REF#	PART#	DESCRIPTION	QUANTITY
1	76-398-01	Drive Shaft (splined)	1
2	60-343-08	Needle Bearing (with housing)	1
3	77-239-01	Housing	1
4	77-239-02	O-Ring	1
5	77-239-03	Thrust Bearing	2
6	77-239-04	Trunnion Cover	1
7	77-239-05	Pan Head Screw	2
8	77-239-06	Washer	6
9	77-239-07	Cone Bearing	2
10	77-239-08	Cam Plate	1
11	77-239-09	Swash Plate Insert	1
12	60-343-21	Rotating Kit	1
13	77-239-10	Crush Ring	1
14*	60-343-12	Shaft Seal	1
15	77-239-11	Seal Cover	1
16	77-239-12	Key	1
17*	77-239-13	Gasket	1
18		Back Plate	1
19	33-058-27	Dowel Pin	2
20	60-343-23	Bearing	1
21	77-239-15	Relief Valve	2
22	77-239-16	Tow Valve Assembly	1
23		Charge Pump Adapter	1
24	77-239-17	Cap Screw	2
26	77-239-18	Cap Screw	2
27*	77-239-19	O-Ring	1
28		Gerotor and Coupler	1
29	77-239-20	End cover Assembly	1
30*	77-239-21	Retaining Ring	2
31	60-343-05	Bearing Race	1
32	60-343-06	Thrust Bearing	1
33	60-343-03	Washer	2
34*	60-343-02	Shaft Seal	1
35*	60-343-01	Retaining Ring	1
* 77-239-23		Seal Repair Kit	

48-267 REPAIR DISASSEMBLY INSTRUCTIONS

Disassembly

The following disassembly procedure applies to a single pump with or without gear pump. The repair procedure for tandem pumps, once they are separated, is basically the same. The basic configuration differences between a single and tandem pumps are the backplates, pump shafts and housing assemblies. In most cases, only the rear pump of tandem units contain a charge pump, which is common to both the front and rear pump. The rear tandem pump does not incorporate a shaft seal.

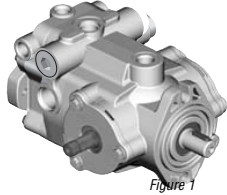

Figure 1

Thoroughly clean the Eaton Model 70160 or 78162 variable displacement pump before any repairs are attempted. When working on tandem pumps, separate the front and rear pumps first.

1 Support the pump with the input shaft down. Use a 1/2 in. socket or end wrench to remove the pump adapter cover plate or gear pump (see Figure 2).



Figure 2

2 Use a pick or similar tool to remove the adapter cover plate or gear pump o-ring. (See Figure 3)

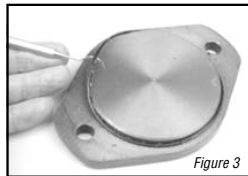

Figure 3

3 Use a 7/16 in. Allen wrench or bit socket remover to remove the charge pressure relief valve spring retainer from the pump adaptor assembly (see Figure 4).



Figure 4

4 Use a pencil magnet or similar tool to carefully remove the charge pressure spring and poppet from the pump adaptor assembly. (See Figure 5) Use caution not to drop the charge pump poppet into the pump adaptor assembly.

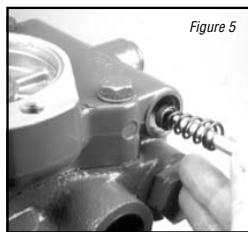

Figure 5

5 The charge pressure relief valve and poppet may be of the standard or high pressure type. The (6.9 to 10.3 bar [100 to 150 PSI]) standard spring and poppet are shown on the bottom and the optional high pressure (13.7 to 20.7 bar [200 to 300 PSI]) spring and poppet is shown on the top.

The same charge pressure relief valve spring retainer is used with either the standard or high pressure (see Figure 6).

6 Use a 7/8 in. socket or end wrench to remove the optional bypass valve assembly from the backplate (see Figure 7).



Figure 6

7 The internal seal may be replaced by first removing the small retaining ring on the end of the bypass valve. Remove and replace the o-rings (see Figure 8).

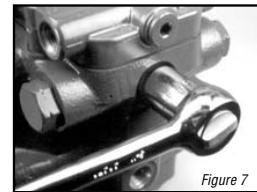

Figure 7

8 Use a 9/16 in. hex key to remove the two high pressure relief valves from the pumps backplate assembly (see Figure 9). Remove relief valve as shown from each side (see Figure 10). Each system relief valve S/A is identified by both its part number and relief valve setting as shown in Parts Information manual.

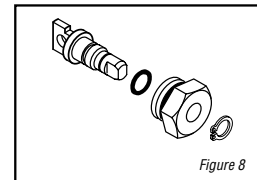

Figure 8

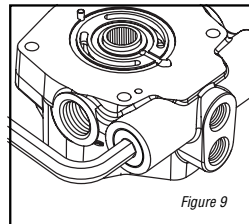

Figure 9

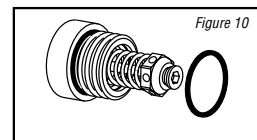

Figure 10

9 Firmly support the pump assembly. Use a 1/2 in. socket or end wrench to remove the four cap screws retaining the charge pump adaptor assembly.

10 With the cap screws removed, remove the charge pump adaptor assembly from the backplate (see Figure 11).

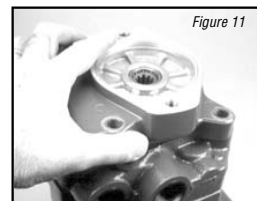

Figure 11

Note: The front pump assemblies do not have charge pump adapter assemblies.

11 Turn the adapter assembly over. Use an o-ring pick or similar tool remove the o-ring seal (see Figure 12).



Figure 12

12 Inspect the gerotor pocket and needle bearing located in the charge pump adapter. The needles in the needle bearing must remain intact in the bearing cage.

13 When the needle bearing assembly is replaced, the numbered end of the bearing must face toward the flange side of the adapter to the dimension as shown (see Figure 13).

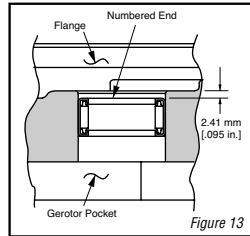

14 With the charge pump adapter removed, remove the charge pump outerring and inner gerotor ring assembly (see Figure 14 and 15).

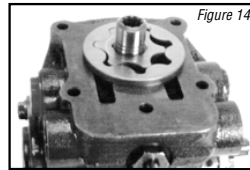

15 Charge pumps are available in two different displacements. Charge pump displacements are based on the thickness of the gerotor assembly and the depth of the pocket located in the charge pump adapter. To determine the displacement, refer to the table below.

Gerotor Pocket Depth

Displacement cm ³ /r [in ³ /r]	Depth of Pocket mm [in.]
6.9 [.42]	6.35 [.25]
13.8 [.84]	12.7 [.50]

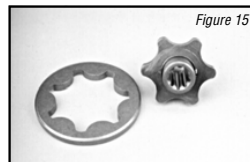

16 To separate the backplate assembly from the dowel pins in the pump housing assembly, insert two screwdrivers between backplate and housing assembly and pry upward (see Figure 16).

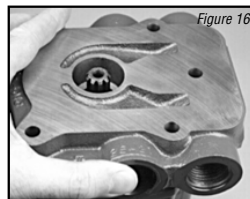

17 After separation, remove the backplate from the housing assembly.

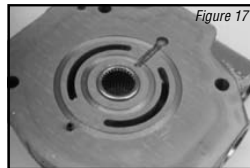

18 Turn the backplate assembly over and inspect the needle bearing. The needles in the needle bearing must remain intact in the bearing cage (see Figure 17).

19 When the needle bearing assembly is replaced, the numbered end of the bearing must face the valve plate side of the backplate to the dimension as shown (see Figure 18).

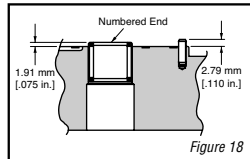

20 With the backplate removed, remove the gasket from the pump housing assembly and discard (see Figure 19).



21 Remove the valve plate from the piston block assembly. Note: This valve plate may have stuck to the backplate assembly that was previously removed.

22 Valveplate directional rotation (CW or CCW) is identified by the location of the metering slots located on the face of the valve plates. Pump input rotation should always turn into the metering slots (see Figure 20). A clockwise valve plate is shown on the left and a counter clockwise valveplate is on the right.

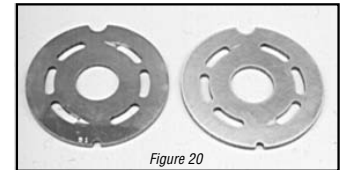

Note: Whenever pump input rotation is changed, the valve plate must be replaced along with the desired rotation charge pump adapter.

23 Remove the rotating kit assembly by carefully retaining it in the housing assembly (see Figure 21). Lift the housing and rotating kit assembly and turn over assemblies allowing the rotating kit assembly to slide down the input shaft and out of the pump housing.

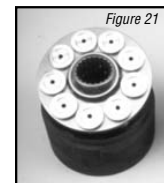

24 With the rotating kit assembly removed, remove the piston assemblies, spider and spider pivot from the piston barrel. (see Figure 22).



25 Inspect the piston assemblies, spider, spider pivot and piston block. The piston block assembly usually requires no further disassembly unless the pins or block spring are damaged.

26 When any excessive wear or scratches are noted on the face of the piston block, the block assembly must be replaced (see Figure 23).



DO NOT LAP THE FACE OF PISTON BLOCK ASSEMBLY.

27 To remove the input shaft assembly, use a pair of internal snap ring pliers and remove the shaft seal retaining ring from the housing assembly (see Figure 24).



48-267 REPAIR DISASSEMBLY INSTRUCTIONS

28 With the retaining ring removed, use a small press to press the shaft seal and input shaft assembly from the housing assembly.

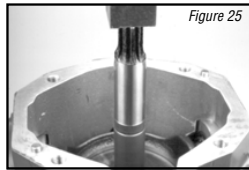

29 With the input shaft assembly removed, disassemble the assembly for inspection by removing the shaft seal, washer, retaining ring thrust washers and bearing (see Figure 26).



Note: The rear pump on tandem units uses a spacer in place of shaft seals.

30 To remove the camplate from the housing assembly, use a 9/16 in. socket or end wrench and remove the three cap screws and washers retaining the control arm cover plate assembly. Start at the cover plate with control arm (see Figure 27).

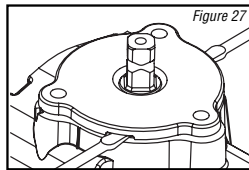

31 With the retaining cap screws removed, insert two small screwdrivers in the notches located in the cover plate assembly and pry upward. Make sure bearing cup comes off with the cover plate (see Figure 28).

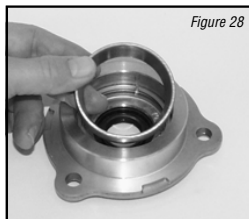

Note: The crush ring in the control arm trunnion cover does not need to be removed (see Figure 29). The only time the crush ring needs to be removed is when either the trunnion cover, the camplate assembly or the housing assembly is replaced. A shim kit is then required in the crush ring's place.

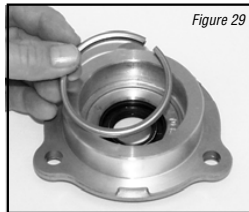

32 Reposition the pump assembly to remove opposite cover plate. The bearing cup in this cover plate is press fit and not removable. Repeat steps 30 through 31.

32b Remove the slip fit bearing on the non-control arm side of the camplate.

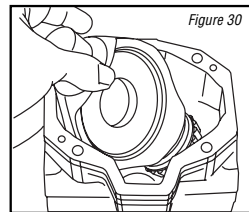

33 With housing in the upright position, slide the camplate toward the control side and lift it from the pump housing (see Figure 30).

Note: The camplate control shaft will fit out either side of the pump housing. Be sure to note on which side of the housing the control shaft protrudes before removing camplate from

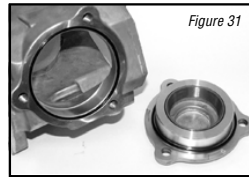

34 Use an o-ring pick or similar tool to remove the o-ring seals from the two counter-bores in the housing or the cover plates (see Figure 31).

35 To remove the control side cover plate lip seal, use a small press and press the lip seal inward (see Figure 32).

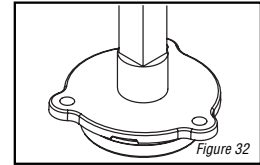

36 Remove the thrust plate from the camplate. The thrust plate is reversible and either side may face the camplate (see Figure 33).

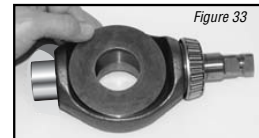

37 Inspect the housing assembly's front needle bearing. If the needles remain in their cage and move freely, replacement usually is not required (see Figure 34).

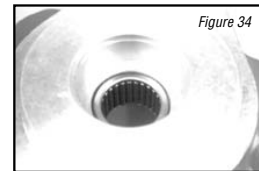

38 When the needle bearing is replaced, the numbered end of the needle bearing must face away from the housing and pressed to the dimension as shown (see Figure 35).

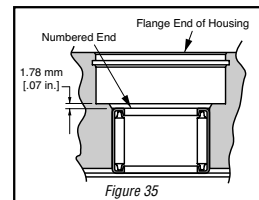

Reassembly

1 Before reassembling the pump, replace all worn and damaged parts, assemblies, seals and o-rings. Lubricate the seals and o-rings with petroleum jelly to help retain them during reassembly and to provide lubrication to the input and control shaft seals. Lubricate all finished part surfaces freely with clean hydraulic fluid to help provide start up lubrication between all rotating parts.

2 To reassemble the camplate assembly into the pump housing, tilt the camplate slightly and install the control side of the camplate through the previously noted or marked side of the housing assembly (see Figure 36).

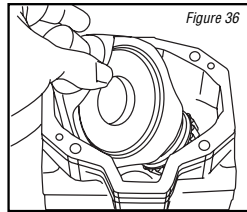

3 Lubricate the tapered bearing and reassemble it on the non-control arm side of the camplate (see Figure 37).

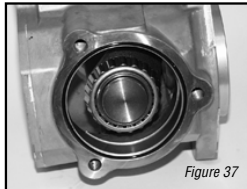

4 Lubricate and install the o-ring seal into counter-bore of housing (see Figure 37).

5 Install the trunnion cover over bearing and onto pump housing. Install the three cap screws and washers, torque screws to 39,3 Nm [29 ft-lb] (see Figure 38).

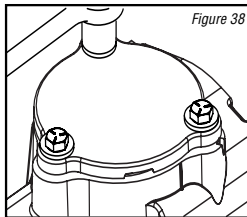

6 Lubricate and install the control arm shaft seal into the control arm cover plate. Install with the lip of the seal facing upward or to the inside of the pump (see Figure 39).

7 If the housing, trunnion covers or camplate assembly have not been replaced, the existing crush ring may be re-used. If you have replaced anyone of the above a shim kit must replace the crush ring. See Parts Information manual for number.

8 Place the bearing cup into trunnion cover over the crush ring or shims (see Figure 40).

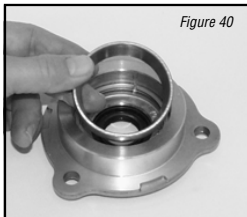
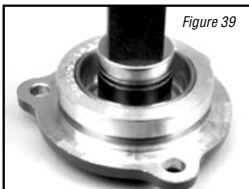

9 Lubricate and install the o-ring seal into counter-bore of housing (see Figure 41).

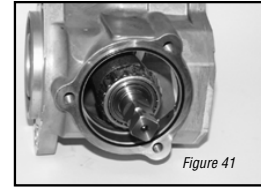

10 Install the trunnion cover over the control shaft and into the pump housing. Install the three retaining cap screws and washers, torque screws to 39,3 Nm [29 ft-lb] (see Figure 42).

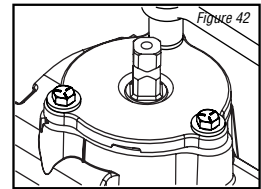

11 Using your fingers, tilt the camplate back and forth to check the trunnion bearing preload. Proper preload is achieved when the camplate has a very slight tilting resistance. The camplate must not have any or very little side clearance.

12 Reassemble the input shaft assembly by installing the thrust washer, thrust bearing, second thrust washer, retaining ring, washer and shaft seal (see Figure 43).



Note: The lip of the shaft seal must point toward the center of the input shaft.

13 Install the input shaft assembly into the housing assembly. Push the shaft seal in just far enough so you can start the shaft seal retaining ring.

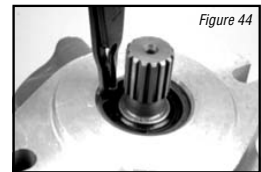

14 Use a pair of snap ring pliers to install retaining snap ring into the housing assembly (see Figure 44).

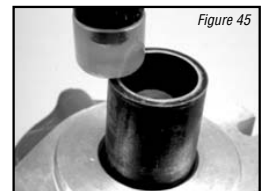

15 Use a seal driver or similar tool to press or drive the snap ring and seal into the housing assembly (see Figure 45).

CAUTION! Press or drive inward until the snap ring snaps into the snap ring groove located in the pump housing assembly.

16 The thrust plate is reversible. Either side will fit into the camplate. In most cases if any irregularities are noted it is best to replace the thrust plate (see Figure 46).

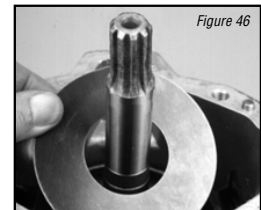

48-267 REPAIR ASSEMBLY INSTRUCTIONS

18 Lubricate and install the thrustplate over the input shaft assembly and into the camplate. The thrustplate must rest firmly in its pocket located in the camplate.

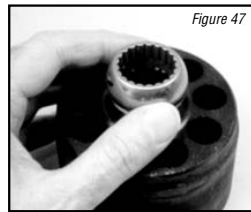

19 Reassemble the rotating kit assembly by first aligning the splines in the pivot with the splines in the block. Install the pivot on the block assembly pins (see Figure 47).



20 Use a small socket or similar tool to help retain the pivot in the centered position. Lubricate and install the spider and piston assemblies onto the pivot and pistons into the piston block assembly (see Figure 48).

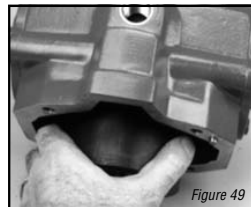

21 Hold the housing assembly in the vertical position then carefully install the rotating kit by first aligning with the splines on the input shaft. With splines aligned, install the rotating kit into the pump housing (see Figure 50). Use caution to ensure all parts are kept in their proper position.

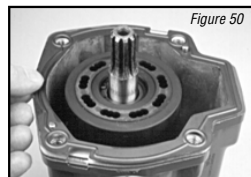

22 With the rotating kit installed, reposition the housing assembly in the input shaft down position and install a new housing gasket (see Figure 50).

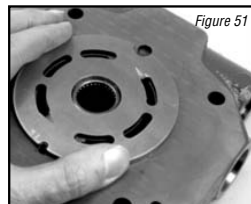

23 Lightly coat the backplate side of the valve plate with petroleum jelly for retention during assembly. Install the valve plate over the needle bearing, aligning the small slot on the outside of the valve plate with the dowel pin in the backplate (see Figure 51).

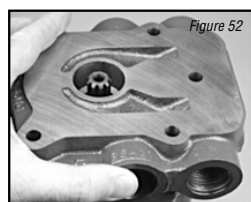

24 Carefully install the backplate assembly by aligning it with the dowel pins located in the pump housing. Use caution not to dislodge the valve plate (see Figure 54).

25 Align the spline of the gerotor's inner ring, then lubricate and install the inner ring and outer ring over the input shaft and onto the backplate assembly (see Figure 53).

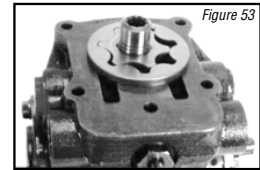

Note: Before installing the charge pump adaptor plate, offset the outer ring of the gerotor as shown.

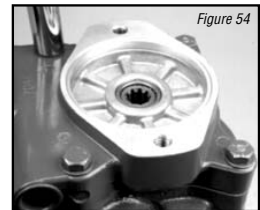

26 With the gerotor assembly installed, install new o-ring into charge pump adaptor plate and place adapter onto backplate over gerotor. Retain with cap screws. Torque cap screws to 25 N•m [18.5 lbf•ft] (see Figure 54).

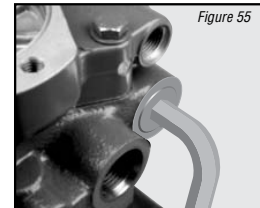

27 Install the two high pressure relief valves. Torque valves 128,8 to 142,4 Nm [95 to 105 lb-ft] (see Figure 55).

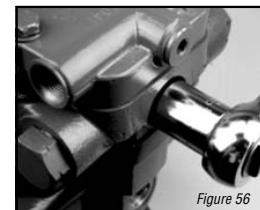

29 Lubricate and reassemble the bypass valve assembly. Install the bypass valve into the backplate. Torque valve to 30,5±2 Nm [22.5±1.5 lb-ft] (see Figure 56).

30 Coat the charge pressure poppet with petroleum jelly and place poppet onto spring and install into the adapter plate (see Figure 57).



31 Install the hollow charge pressure relief valve retainer into the adapter plate. Torque retainer to 6,8 to 9,5 Nm [5 to 7 lb-ft].

32 Lubricate and install the o-ring on the cover plate or gear pump. Install the cover plate or gear pump and two cap screws. Torque cap screws to 36,6 to 40 Nm [27 to 31 lb-ft].

The Model 70160 or 78162 variable displacement pump is now ready for test and reinstallation.

This fault - logic troubleshooting guide is a diagnostic aid in locating transmission problems.

Match the transmission symptoms with the problem statements and follow the action steps shown in the box diagrams. This will provide help in correcting minor problems eliminating unnecessary machine down time.

Following the fault - logic diagrams are diagram action comments of the action steps shown in the diagrams. Where applicable, the comment number of the statement appears in the action block of the diagrams.

Explanatory Diagram

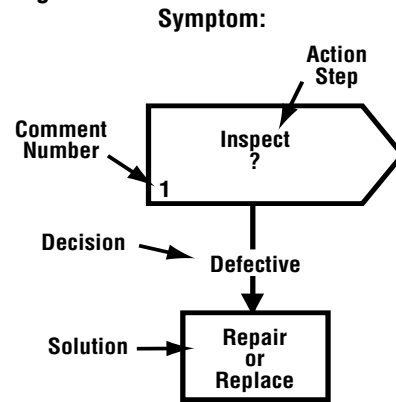

Recommended Gauge Locations

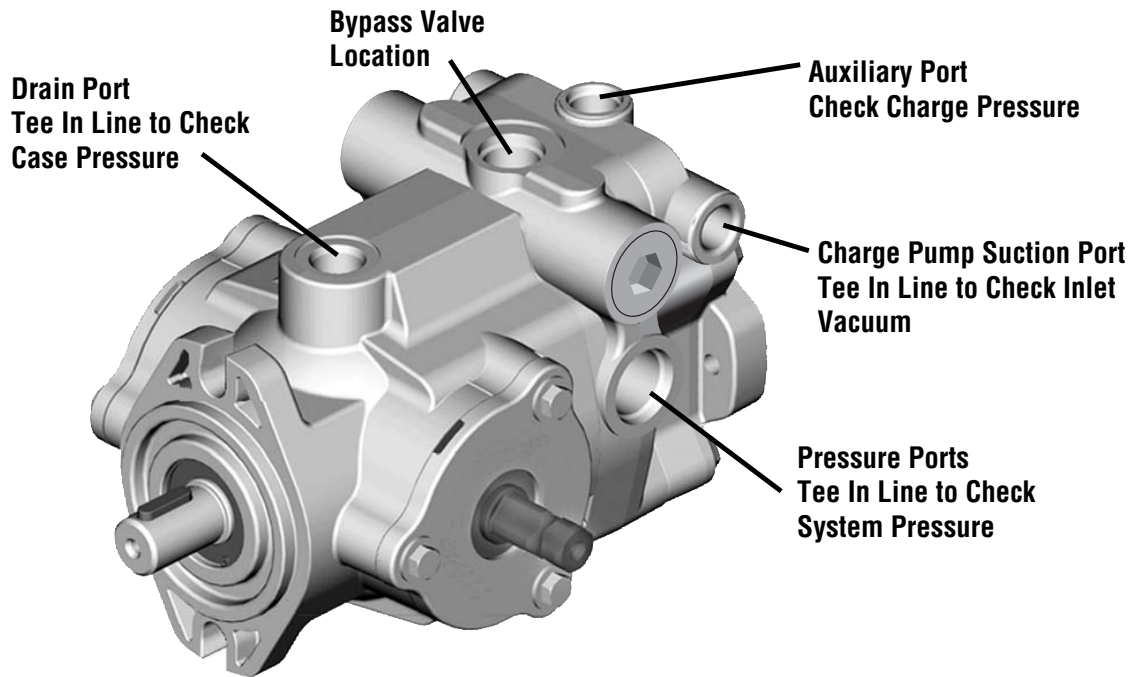

Figure 58

Gauges Recommended

- Inlet vacuum gauge: 2 bar to 1 bar [30 PSI to 30 inHg]
- System pressure gauge: 700 bar [10,000 PSI]
- Charge pressure gauge: 0 to 50 bar [0 to 600 PSI]
- Case pressure gauge: 0 to 25 bar [0 to 300 PSI]

Symptom: System Will Not Operate In Either Direction

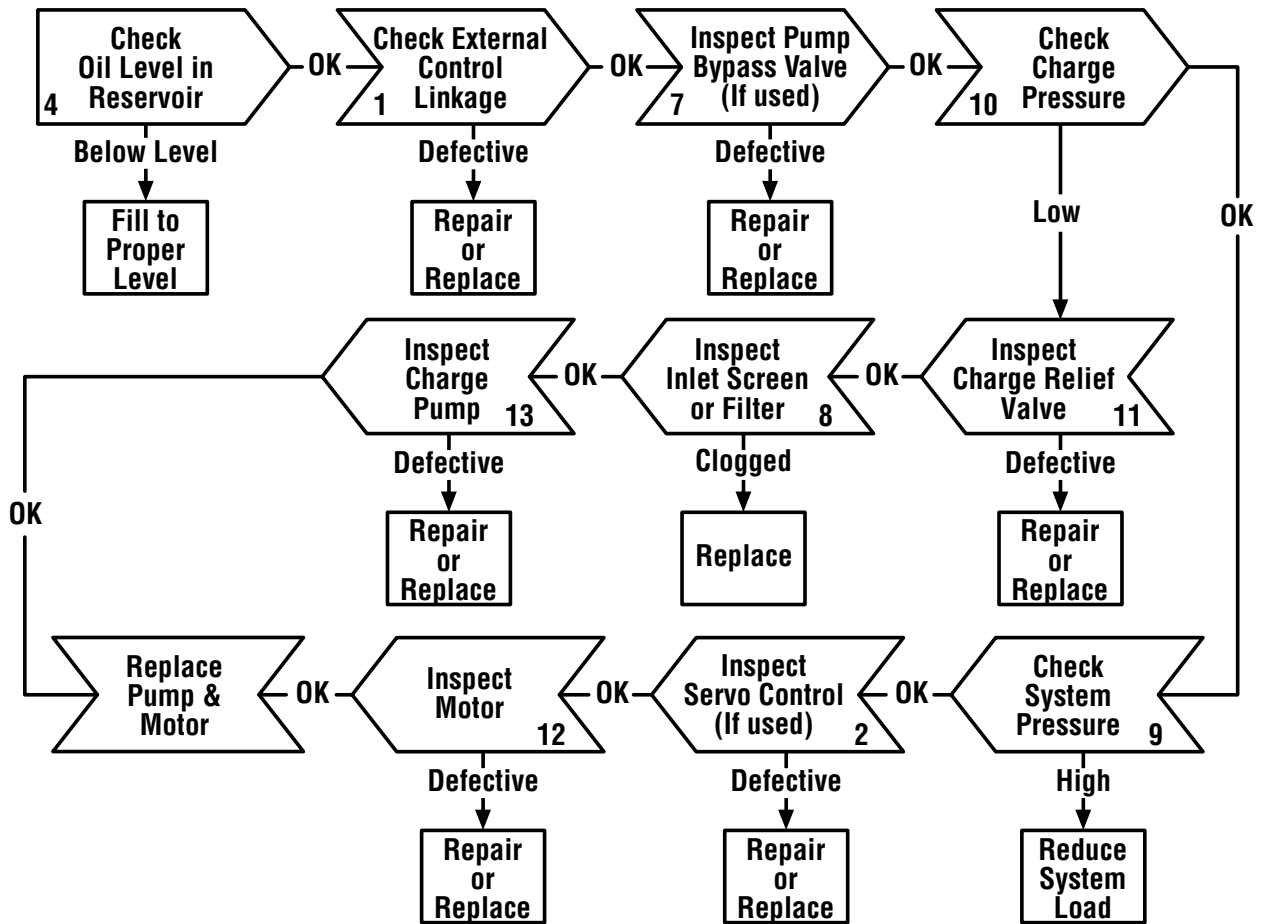

Diagram Action Step Comments

- 1 Inspect External Control Linkage for:**
 - a. misadjustment or disconnection
 - b. binding, bending or breakage
 - c. misadjusted, damaged or broken neutral return spring
- 2 Inspect Servo Control Valve for: (if used)**
 - a. proper inlet pressure
 - b. misadjusted, damaged or broken neutral return spring
 - c. galled or stuck control spool
 - d. galled or stuck servo piston
- 3 Inspect System Relief Valves* for:**
 - a. improper pressure relief setting
 - b. damaged or broken spring
 - c. valve held off seat
 - d. damaged valve seat
- 4 Check Oil Level in Reservoir:**
 - a. consult owner/operators manual for the proper type fluid and level
- 5 Inspect Heat Exchanger for:**
 - a. obstructed air flow (air cooled)
 - b. obstructed water flow (water cooled)
 - c. improper plumbing (inlet to outlet)
 - d. obstructed fluid flow
- 6 Inspect Heat Exchanger Bypass Valve for: (if used)**
 - a. improper pressure adjustment
 - b. stuck or broken valve
- 7 Inspect Pump Bypass Valve for: (if used)**
 - a. held in a partial or full open position
- 8 Inspect Inlet Screen or Filter for:**
 - a. plugged or clogged screen or filter element
 - b. obstructed inlet or outlet
 - c. open inlet to charge pump
- 9 Check System Pressure:**
 - a. See figure 60 for location of pressure gauge installation.
 - b. consult owner/operators manual for maximum system relief valve settings
- 10 Check Charge Pressure:**
 - a. See figure 60 for location of pressure gauge installation.
 - b. consult owner/operators manual for maximum charge relief valve settings

- 11 Inspect Charge Relief Valve for:**
 - a. improper charge relief pressure setting *
 - b. damaged or broken spring
 - c. poppet valve held off seat

- 12 Inspect Motor for:**
 - a. disconnected coupling

- 13 Inspect Charge Pump for:**
 - a. broken or missing drive key
 - b. damaged or missing o-ring
 - c. excessive gerotor clearance
 - d. galled or broken gerotor set

*** System/Charge Relief Valve Pressure Settings for Eaton's Variable Displacement Controlled Piston Pumps**

Inlet Vacuum	6 inHg max.
Case Pressure	25 PSI maximum
Charge Pressure	100 to 150 PSI Standard 200 to 250 PSI Optional 250 to 300 PSI Optional
System Pressure	5000 PSI maximum 3000 PSI continuous

The high pressure relief valves are all factory preset and cannot be readjusted.

The pressure setting and assembly number is stamped on each high pressure relief valve cartridge.

Valve Identification Example:

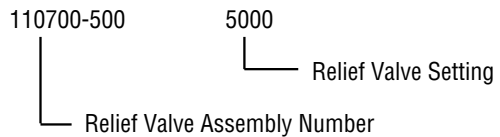

48-267 START-UP PROCEDURE

When starting a new or rebuilt transmission system, it is extremely important to follow the start-up procedure. It prevents the chance of damaging the unit which might occur if the system was not properly purged of air before start-up.

- 1 After the transmission components have been properly installed, fill the pump housing at least half full with filtered system oil. Connect all hydraulic lines and check to be sure they are tight.
- 2 Install and adjust all control linkage.
- 3 Fill the reservoir with an approved oil that has been filtered through a 10 micron filter. Refer to Eaton Hydraulics Technical Data Sheet number 3-401 titled [Hydraulic Fluid Recommendations](#).
- 4 For Gasoline engines or L.P. engines remove the coil wire and turn the engine over for 15 seconds. For Diesel engines shut off the fuel flow to the injectors and turn the engine over for 15 seconds.
- 5 Replace the coil wire or return the fuel flow to the injectors. Place the transmission unit in the neutral position, start the engine and run it at a low idle. The charge pump should immediately pick up oil and fill the system. If there is no indication of fill in 30 seconds, stop the engine and determine the cause.

- 6 After the system starts to show signs of fill, slowly move pump camplate to a slight cam angle. Continue to operate system slowly with no load on motors until system responds fully.
- 7 Check fluid level in the reservoir and refill if necessary to the proper level with an approved filtered oil.
- 8 Check all line connections for leaks and tighten if necessary.

The machine is now ready to be put into operation.

Frequent filter changes are recommended for the first two changes after placing the machine back into operation. Change the first filter in 3-5 hours and the second in approximately 50 hours. Routinely scheduled filter changes are recommended for maximum life of the hydraulic system.

48-266 GEAR PUMP

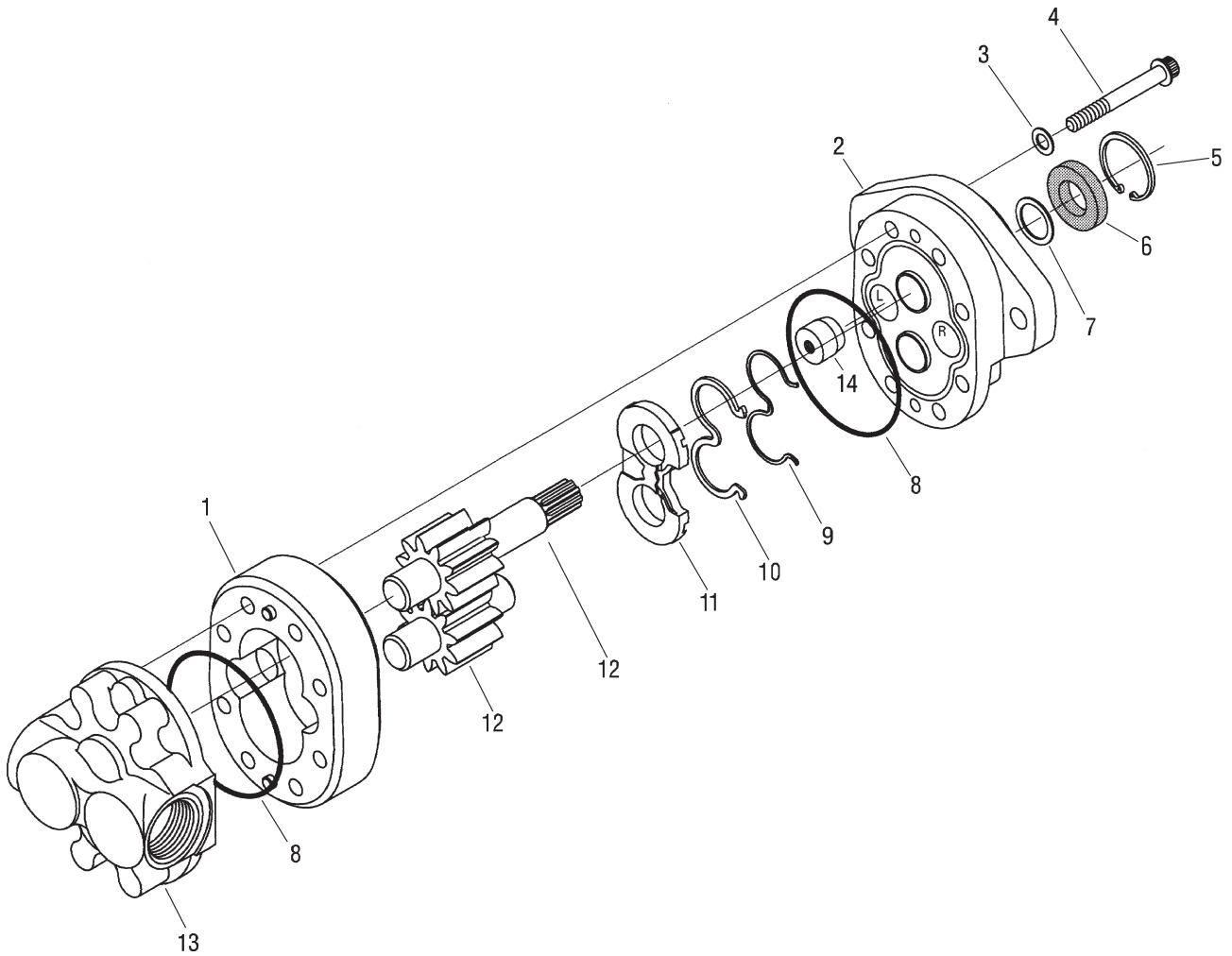

Parts

REF#	PART#	DESCRIPTION	QUANTITY
1		Body	1
2	76-197-01	Front Plate	1
3*		Washer	4
4	76-197-06	Cap Screw	8
5	76-197-07	Retaining Ring	1
6*		Shaft Seal	1
7	33-061-15	Washer	1
8*		O-Ring	2
9*		Backup Gasket	1
10*		Seal	1
11*		Wear Plate	1
12	76-197-04	Shaft (comes with Idler Gear)	1
13	76-197-02	Back Plate	1
14*		Plug	1
*	76-197-08	Seal Kit	

Disassembly

Repair Information - Model 26000

Work in a clean area; cleanliness is extremely important when repairing hydraulic pumps. Before disconnecting the lines, clean port areas of pump. Disconnect hydraulic lines, removing pump assembly from vehicle and plugging ports. Thoroughly clean the outside of the pump. After cleaning, remove port plugs and drain oil.

Disassembly of a Triple Pump

During disassembly keep all mating part in order and together.

- 1 Remove *key* from drive shaft if keyed drive gear assembly is used.
- 2 Put a *location mark* across front plate, bodies, adapters and backplate to assure proper reassembly.



- 3 Clamp pump in vise, shaft end up. Caution must be used as excessive clamping pressure on pump housing may distort the housing.
- 4 Remove *cap screws* (eight each) and washer (four each).



- 6 Start by tapping the backplate with a soft faced hammer to remove from the third pump body. Remove *o-ring* seal from backplate.
- 7 To disassemble the *relief valve backplate and flow divider backplate* see page 15.

- 5 Remove pump from vise and position pump so that the shaft end is down. Now disassembly will continue from the rear of the pump.

Disassembly

8 To separate the *third pump body* from adapter plate use a soft faced hammer and tap to loosen and then lift straight up.



9 Remove *idler gear assembly* from wear plate and adaptor plate.



10 Remove *drive gear* from input shaft.



11 Remove *wear plate and o-ring seal*, noting position of open or closed side of wear plate.



12 Using a pencil magnet remove the *drive gear key* from the drive shaft.



13 Using an o-ring pick or similar tool remove the *o-ring seal* from the rear adapter plate.

14 Tap rear *adapter plate* with a soft faced hammer to loosen and remove adapter plate. After removing adapter, turn it over and remove the *second o-ring seal*.



48-266 REPAIR DISASSEMBLY INSTRUCTIONS

15 Remove *second or middle pump body* from second set of gears.



16 Remove *idler gear assembly* from wear plate and *drive gear* from input shaft.



17 Remove the next (second) *wear plate assembly* from the adapter.

18 Next, use a pencil magnet to remove the *second drive key* from the pump shaft.



19 Remove the *o-ring seal* from the front adapter plate.

20 Tap *front adapter plate* with a soft faced hammer to loose and remove adapter plate. After removing adapter, turn it over and remove the *second o-ring seal*.



21 Remove *first pump body* from front plate.



22 Remove *first pump idler gear* and *input drive gear assembly* along with *wear plate* and *o-ring seal* from front plate.



48-266 REPAIR DISASSEMBLY INSTRUCTIONS

23 Remove *back-up gasket and seal* from all wear plates.



24 Using a drift punch or similar tool, remove the *shaft seal* from the front plate. Caution is needed not to damage counter bore of shaft seal area when removing seal.

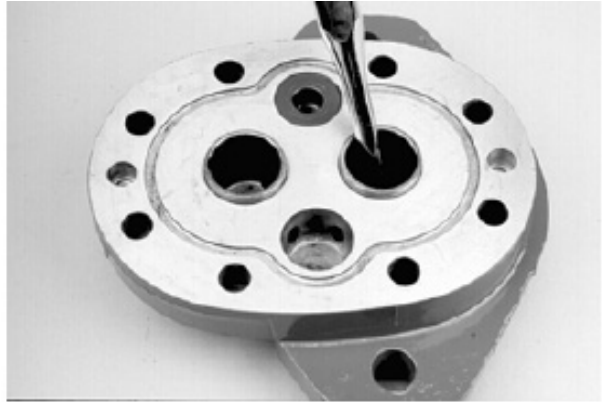

25 Removing the *plug* in front plate is not necessary, unless you intend to change rotation. See Reversibility - Changing Input Rotation of Pump.

Service

Plate Identification

Improvement has been made to the Model 26000 gear pump with a new designed wear plate. To identify the new wear plate for grooves placed in the seal side of the wear plate as shown below.

OLD
Wear Plate

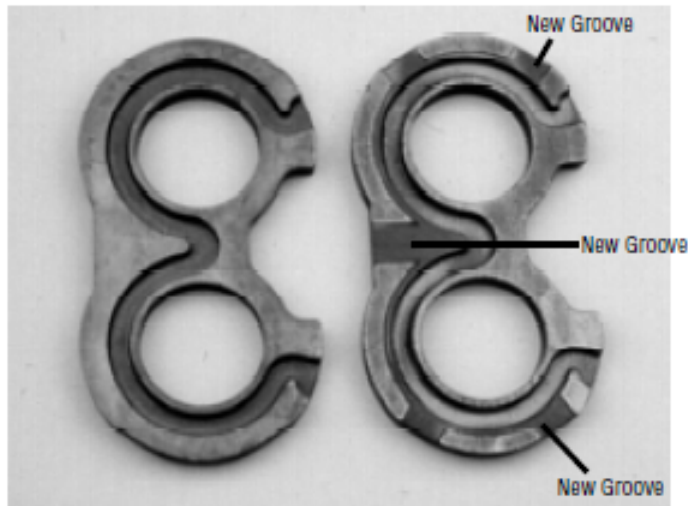

NEW
Wear Plate

The new wear plate enables better pressure clamping with aerated oil in pumps 1.37 cubic inch or smaller. Aerated oil during a cold start-up in applications with long suction lines or when the mouth of the inlet line is temporarily air.

Inspection

Inspect Parts for Wear

General

- 1 Clean and dry all parts.
- 2 Remove all nicks and burrs from all parts with emery cloth.

Gear Assembly Inspection

- 1 Check spline drive shaft for twisted or broken teeth or check keyed drive shaft for broken or chipped keyway.
- 2 Inspect both the drive gear and idler gear shafts at bushing points and seal area for rough surfaces and excessive wear.
- 3 Replace gear assembly if shaft measures less than 19 mm [.748 in] in bushing area. (One gear assembly may be replaced separately; shafts and gears are available as assemblies only.)
- 4 Inspect gear for scoring and excessive wear.
- 5 Replace gear assembly if gear width is below the following dimensions. Refer to chart on this page.
- 6 Assure that snap rings are in grooves on either side of drive and idler gears.
- 7 If edge of gear teeth are sharp, break edge with emery cloth or stone.

Front plate and Backplate Inspection

- 1 Oil groove in bushings in front plate should be in line with dowel pin holes and 180° apart. The oil grooves in the backplate bushings should be at approximately 37° to the pressure side.
- 2 Replace the backplate, adapter plate or front plate if I.D. of bushings exceed 19,2 mm [.755 in] (Bushings are not available as separate items).
- 3 Bushings in front plate should be at 3,20 mm [.126 in] above surface of front plate.
- 4 Bushings in adapter plate on the wear plate side should be at 3,20 mm [.126 in] above surface of adapter.
- 5 Check for scoring on face of backplate or backplate side of adapter plate. Replace if wear exceeds ,038 mm [.0015 in].

Body Inspection

- 1 Check body inside gear pockets for excessive scoring or wear.
- 2 Replace body if I.D. of gear pockets exceeds 43,7 mm [1.719 in].

Minimum Gear Width per Displacement

Model Number	26001	26002	26003	26004	26005	26006	26007	26008	26009	26010	26011	26012	26013
Pump Disp. cm ³ /r [in ³ /r]	6,6 [.40]	8,2 [.50]	9,5 [.58]	10,8 [.66]	13,8 [.84]	16,7 [1.02]	19,7 [1.20]	22,5 [1.37]	24,3 [1.48]	25,2 [1.54]	27,7 [1.69]	29,0 [1.77]	30,6 [1.87]
Gear Width mm [in]	7,85 [.309]	9,75 [.384]	11,20 [.441]	12,95 [.510]	16,15 [.636]	19,35 [.762]	22,56 [.888]	25,76 [1.014]	28,12 [1.107]	28,96 [1.140]	32,16 [1.266]	33,78 [1.330]	35,36 [1.392]

Reassembly

General Information

It is important that the relationship of the backplate, bodies, adapters, wear plates, and front plate is correct. You will note two half moon cavities in the body. The smaller half moon port cavity must be on the pressure side of the pump. The side of wear plate with midsection cut out must be on suction side of pump. Suction side of backplate or adapter is always side with larger port boss.

Reassembly

1 During the reassembly, replace and lubricate all of the *wear plates, seals, back-up gaskets, shaft seal and o-rings* as new parts. Lubricate all finished parts and/or assembly surfaces freely with clean hydraulic fluid during assembly.

2 Install *o-ring* in groove of front plate.



3 Apply a thin coat of petroleum jelly or hydraulic oil to both milled gear pockets of body. Slip body onto front plate with half moon port cavities in body facing away from front plate. Check and align the previously scribed line on the exterior of pump unless input rotation was changed.

Note: If rotation was changed, make sure the small half moon port cavity is on the pressure side (the plugged side of the front plate) of the pump.



4 Install new *seal* and new *backup gasket* into all wear plates. Note in the middle of the backup gasket a flat section or support. This area must face away from the wear plate inside the seal.



5 Place the first new *wear plate, seal, and backup gasket* into gear pocket with seal and backup gasket next to front plate. The side of the wear plate with the mid section cut-away must be on the suction side of pump.



6 Dip *gear assemblies* into oil and slip first shaft assemblies into front plate bushings and gears into body pockets.



Reassembly

7 Install new *o-ring* in groove of adapter plate (side with bushings below surface).



8 Align the scribed lines of the first body and front adapter, install adapter plate onto the drive shaft and body.



9 Lubricate and install second *o-ring* onto adapter.

10 Install the drive key into the key slot using some petroleum jelly to help hold it in place.



11 Aligning the previously scribed line of body and adapter, install the second pump body onto the adapter plate.



12 Lubricate and install the second wear plate assembly into the pump body. Caution is required to not dislodge the seals during installation. Remember sealing side of the wear plate is toward the adapter plate with the cut side of the wear plate facing the suction side or large cavity location of pump body.



13 Lubricate and install the second drive gear onto the shaft and into the pump body aligning key with slot in gear.

14 Lubricate and install the second idler gear assembly into body and adapter.



48-266 REPAIR REASSEMBLY INSTRUCTIONS

- 15** Lubricate and install the *new o-ring seal* onto the rear adapter plate.



- 16** Aligning the two previously scribed lines on the body and rear adapter, install *rear adapter* onto pump body. Lubricate and install the *new o-ring seal* onto the other side of rear adapter plate.

- 17** Install the *third drive key* into the key slot using petroleum jelly to help hold it in place.



- 18** Aligning the previously scribed line of body and adapter, install the *third pump body* onto the rear adapter plate.

- 19** Lubricate and install the third wear plate assembly into the pump body. Caution is required to not dislodge the seals during installation. Remember sealing side of the wear plate is toward the adapter plate with the cut side of the wear plate facing the suction side or large cavity location of pump body.



- 20** Lubricate and install the *third drive gear* onto the shaft and into the pump body aligning key with slot in gear.

- 21** Lubricate and install the *third idler gear assembly* into body and adapter.



- 22** Install the *new o-ring seal* in groove of backplate.

- 23** Check scribe line, make sure port orientation is correct and then slide *backplate* over gear shafts until dowel pins are engaged.



- 24** Secure with *cap screws* and *new washers*. Tighten cap screws evenly in a crisscross pattern 34 to 38 N•m [25 to 28 lbf•ft] torque.



48-266 REPAIR REASSEMBLY INSTRUCTIONS

25 Place washer over drive shaft into housing. Liberally oil shaft seal and install over drive shaft, carefully so that rubber sealing lips are not cut.



26 Place 1-5/16 in. O.D. sleeve over shaft and press in shaft seal until its below the surface of the front plate 6.1mm [.24 in]. Install retaining ring if required optional feature is used.

27 Install key on keyed shaft.

Note: Refer to Start-up Procedure and Trouble Shooting Procedure.

Placing Series 26 Gear Pump Back into Operation

When test stand is *available*.

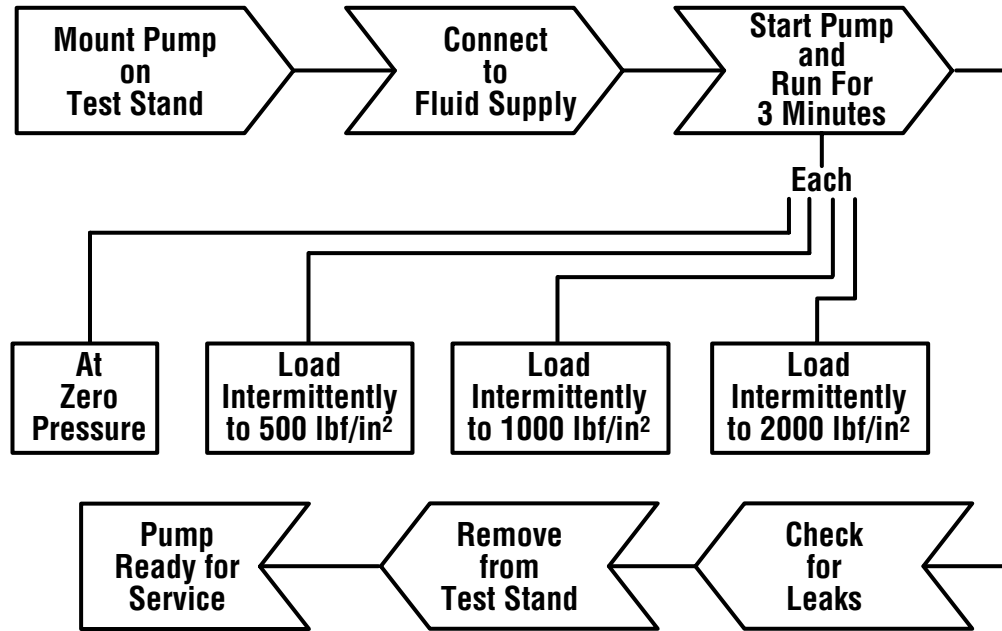

When test stand is *not available*.

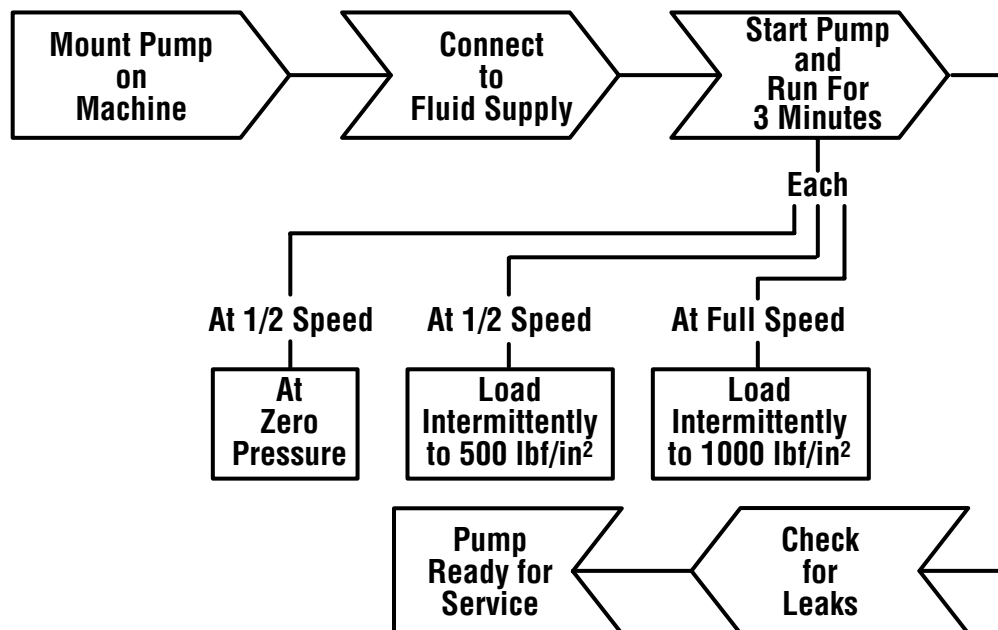

Service

Trouble Shooting

Problem	Possible Cause	Correction
Cavitation	<ul style="list-style-type: none"> a. Oil too heavy. b. Oil filter plugged. c. Suction line plugged or too small. 	<ul style="list-style-type: none"> a. Change to proper viscosity b. Clean filter. c. Clean line and check size of line.
Oil heating	<ul style="list-style-type: none"> a. Oil supply low. b. Contaminated oil. c. Setting of relief valve too high or too low. d. Oil in system too light. 	<ul style="list-style-type: none"> a. Fill reservoir. b. Drain reservoir and refill with clean oil. c. Set to correct pressure. d. Drain reservoir and refill with proper viscosity oil.
Shaft seal leakage	<ul style="list-style-type: none"> a. Worn shaft seal. b. Worn shaft in seal area. c. Debris in shaft seal suction side drain holes. 	<ul style="list-style-type: none"> a. Replace shaft seal. b. Replace drive assembly. c. Disassemble pump and inspect.
Foaming oil	<ul style="list-style-type: none"> a. Low oil level b. Air leaking into suction line c. Wrong kind of oil. 	<ul style="list-style-type: none"> a. Fill reservoir. b. Tighten fittings. c. Drain and fill reservoir with non-foaming oil.

76-238 REAR WHEEL MOTOR (14.5 CI)

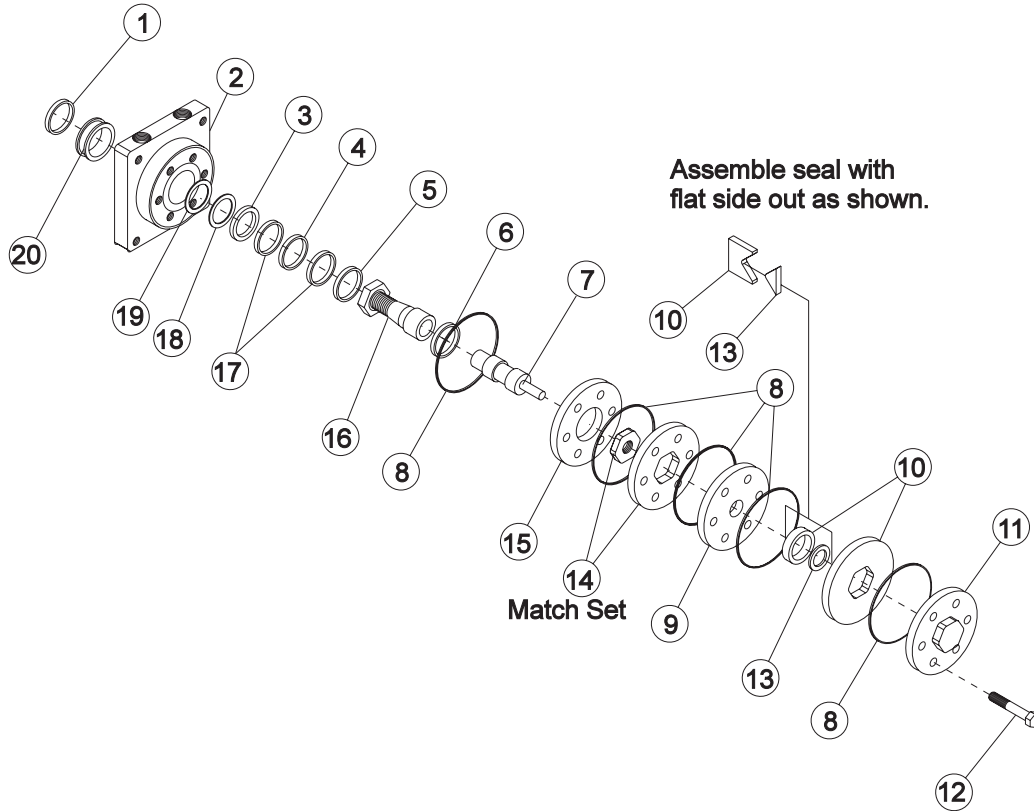

REF#	PART#	DESCRIPTION	QUANTITY
1*		Water & Dirt Seal	1
2†	13-615-05	Service Housing Assembly	1
3*		Inner Seal	1
4†	13-032-27	Thrust Bearing	1
5†	13-032-28	Inner Bearing	1
6	13-032-29	Thrust Bearing	1
7	76-238-03	Drive Link	1
8*		Ring Seal	5
9	13-032-31	Manifold	1
10	13-032-32	Commutator Assembly (matched set)	1
11	13-032-33	End Cover	1
12	76-238-01	Hex Bolt	7
13*		Commutator Seal (matches with #10)	1
14	76-238-02	Rotor Set (matched set)	1
15	13-032-35	Plate Wear	1
16	13-615-04	Coupling Shaft	1
	HWK-516-100	Woodruff Key, $\frac{5}{16} \times 1$	1
	14-265	Nut, 1 - 20	1
17†	13-032-37	Thrust Washer	2
18*		Backup Washer	1
19*		Backup Washer	1
20†	13-032-38	Outer Bearing	1
*	14-080	Seal Kit	1
†	Included in 13-615-05 Service Housing Assembly		

76-238 TROUBLESHOOTING CHECKLIST

Trouble	Cause	Remedy
Oil Leakage	1. Hose fittings loose, worn or damaged.	Check & replace damaged fittings or "O" Rings. Torque to manufacturers specifications.
	2. Oil seal rings (4) deteriorated by excess heat.	Replace oil seal rings by disassembling Torqmotor™ unit.
	3. Special bolt (1, 1A, 1B or 1C) loose or its sealing area deteriorated by corrosion.	(a) Loosen then tighten single bolt to torque specification. (b) Replace bolt.
	4. Internal shaft seal (16) worn or damaged.	Replace seal. Disassembly of Torqmotor™ unit necessary.
	5. Worn coupling shaft (12) and internal seal (16).	Replace coupling shaft and seal by disassembling Torqmotor™ unit.
Significant loss of speed under load	1. Lack of sufficient oil supply	(a) Check for faulty relief valve and adjust or replace as required. (b) Check for and repair worn pump. (c) Check for and use correct oil for temperature of operation.
	2. High internal motor leakage	Replace worn rotor set by disassembling Torqmotor™ unit.
	3. Severely worn or damaged internal splines.	Replace rotor set, drive link and coupling shaft by disassembling Torqmotor™ unit.
	4. Excessive heat.	Locate excessive heat source (usually a restriction) in the system and correct the condition.
Low mechanical efficiency or undue high pressure required to operate Torqmotor™ unit	1. Line blockage	Locate blockage source and repair or replace.
	2. Internal interference	Disassemble Torqmotor™ unit, identify and remedy cause and repair, replacing parts as necessary.
	3. Lack of pumping pressure	Check for and repair worn pump.
	4. Excessive binding or loading in system external to Torqmotor™ unit.	Locate source and eliminate cause.

CAUTION: If the hydraulic system fluid becomes overheated [in excess of 200°F (93.3°C)], seals in the system can shrink, harden or crack, thus losing their sealing ability.

- Clean, petroleum-based solvent
- Emery paper
- Vise with soft jaws
- Air pressure source
- Arbor press
- Screw driver
- Masking tape
- Breaker bar
- Torque wrench-ft. lbs. (N m)
- Sockets: 1/2 or 9/16 inch thin wall, 1 inch
- Allen Sockets: 3/16, 3/8 inch
- Adjustable crescent wrench or hose fitting wrenches
- SAE 10W40 SE or SF oil
- Special bearing mandrel for TH Torqmotors (consult factory)
- Special bearing mandrel for TF, TG & TJ Torqmotors (SEE FIGURE 1)
- Feeler gage .005 inch (.13 mm)
- TH Torqmotors require blind hole bearing puller for a 1.575 inch dia. (40.0 mm) and 2.130 inch dia. (54.1 mm) bearings.
- TF, TG & TL Torqmotors require blind hole bearing puller for 1.400 inch dia. (35.6 mm) and 2.130 inch dia. (54.1 mm) bearings.
- Clean corrosion resistant grease. Part #406018 is included in each seal kit. Recommended grease is Parker Specification #045236 or Mobil Mobilith SHC® 460

NOTE: The available service seal kits include the recommended grease as a grease pack #406018

CAUTION: Mixing greases that have different bases can be detrimental to bearing life.

Torque Chart		
Part Name	Item Number	Torque
bolt 3/8 24 UNF 2A	1, 1A, 1B or 1C	45-55 ft. lbs. (60-76 N m)
bolt 5/8 18 UNF 2A	12D	140-180 ft. lbs. (190-244 N m)
nut 1-20 UNEF 2B	12B (TF, TG, TL)	300-400 ft. lbs. (407-542 N m)

76-238 ASSEMBLY REFERENCE DRAWING

Typical Assembly

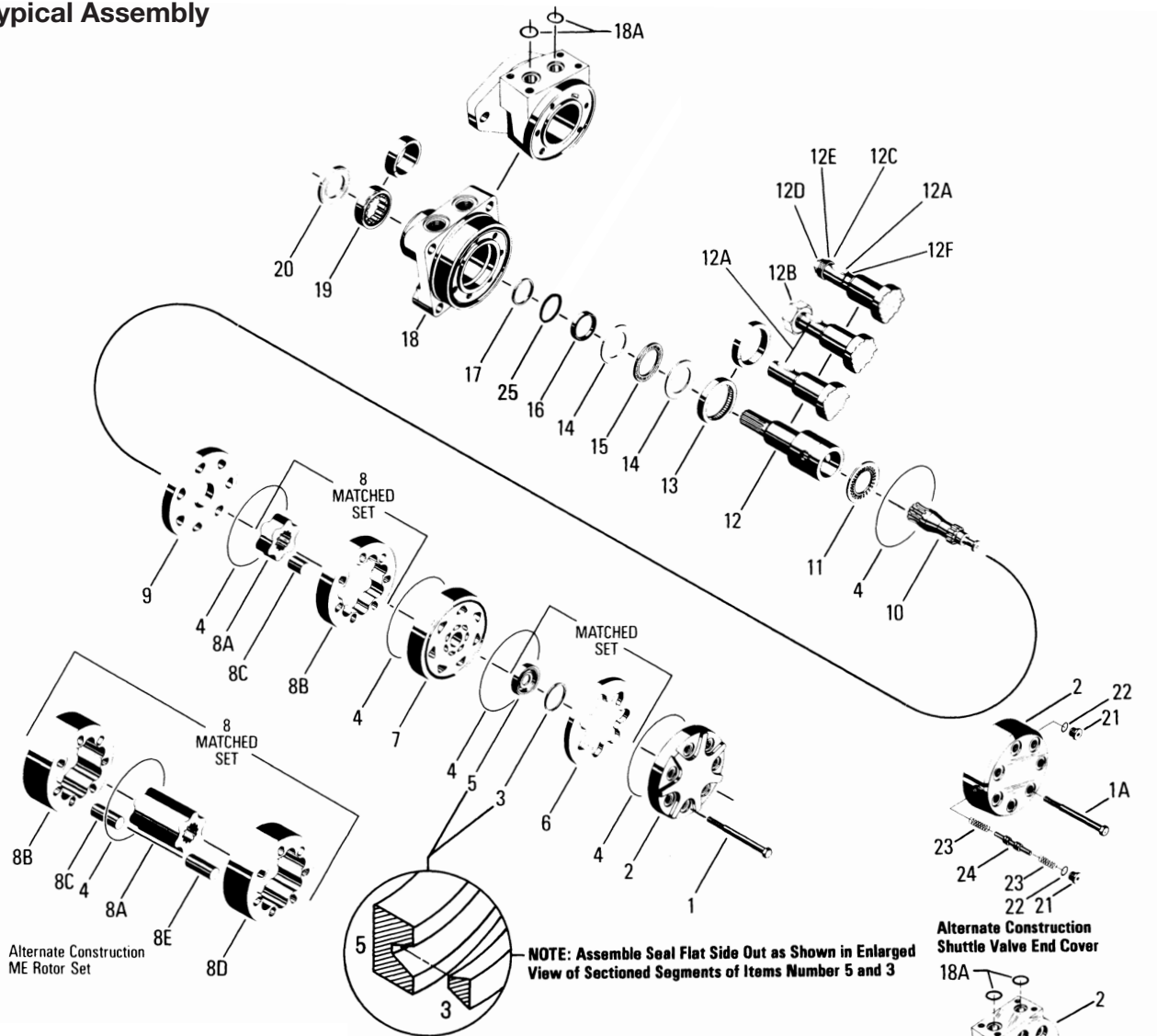

Item

No. Description

- | | | |
|-------------------------------|---------------------|-------------------------------|
| 1. Special Bolts (5, 6, or 7) | 9. Wear Plate | 18. Housing |
| 1a. Special Bolts (7) | 10. Drive Link | 18a. O-Ring (2) |
| 1b. Special Bolts (7) | 11. Thrust Bearing | 19. Bearing, Outer |
| 1c. Special Bolts (7) | 12. Coupling Shaft | 20. Dirt & Water Seal |
| 2. End Cover | 12a. Key | 21. Plug (2) |
| 3. Seal Ring-Commutator | 12b. Nut | 22. O-Ring (2) |
| 4. Seal Ring (5) | 12c. Washer | 23. Spring |
| 5. Commutator | 12d. Bolt | 24. Valve (Shuttle or Relief) |
| 6. Commutator Ring | 12e. Lockwasher | 25. Backup Washer |
| 7. Manifold | 12f. Retaining Ring | |
| 8. Rotor Set | 13. Bearing, Inner | |
| 8a. Rotor | 14. Thrust Washer | |
| 8b. Stator or Stator Half | 15. Thrust Bearing | |
| 8c. Vane (7) | 16. Seal | |
| 8d. Stator Half | 17. Backup Ring | |
| 8e. Vane (7) | | |

= Items not sold separately. Sold as matched sets only.

Preparation Before Disassembly

- Before you disassemble the Torqmotor™ unit or any of its components read this entire manual. It provides important information on parts and procedures you will need to know to service the Torqmotor™.
- Determine the type of end construction from the alternate views shown on the exploded view.
- The Series TF, TG, TL & TH Torqmotors™ will have a 5 inch (127.9 mm) main body outside diameter and seven 3/8 24 UNF 2A cover bolts.
- Refer to “Tools and Materials Required for Services” section for tools and other items required to service the Torqmotor™ and have them available.
- Thoroughly clean off all outside dirt, especially from around fittings and hose connections, before disconnecting and removing the Torqmotor™. Remove rust or corrosion from coupling shaft.
- Remove coupling shaft connections and hose fittings and immediately plug port holes and fluid lines.
- Remove the Torqmotor™ from system, drain it of fluid and take it to a clean work surface.
- Clean and dry the Torqmotor™ before you start to disassemble the unit.
- As you disassemble the Torqmotor™ clean all parts, except seals, in clean petroleum-based solvent, and blow them dry.

WARNING: petroleum-base solvents are flammable. Be extremely careful when using any solvent. Even a small explosion or fire could cause injury or death.

WARNING: WEAR EYE PROTECTION AND BE SURE TO COMPLY WITH OSHA OR OTHER MAXIMUM AIR PRESSURE REQUIREMENTS.

CAUTION: Never steam or high pressure wash hydraulic components. Do not force or abuse closely fitted parts.

- Keep parts separate to avoid nicks and burrs.
- Discard all seals and seal rings as they are removed from the Torqmotor™. Replace all seals, seal rings and any damaged or worn parts with genuine Parker or OEM approved service parts.

76-238 DISASSEMBLY INSTRUCTIONS

Reference Exploded Assembly View

- Place Torqmotor in a vise**
1. Place the Torqmotor™ in a soft jawed vise, with coupling shaft (12) pointed down and the vise jaws clamping firmly on the sides of the housing (18) mounting flange or port bosses. Remove manifold port O-Rings (18A) if applicable.

WARNING **WARNING:** IF THE TORQMOTOR™ IS NOT FIRMLY HELD IN THE VISE, IT COULD BE DISLODGED DURING THE SERVICE PROCEDURES, CAUSING INJURY.

- Scribe alignment mark & loose valve plugs**
2. Scribe an alignment mark down and across the Torqmotor™ components from end cover (2) to housing (18) to facilitate reassembly orientation where required. Loosen two shuttle or relief valve plugs (21) for disassembly later if included in end cover. 3/16 or 3/8 inch Allen wrench or 1 inch hex socket required. SEE FIGURES 2 & 3.

- Remove special bolts & inspect bolts**
3. Remove the seven special ring head bolts (1, 1A, 1B, or 1C) using an appropriate 9/16 inch size socket. SEE FIGURE 4. Inspect bolts for damaged threads, or sealing rings, under the bolt head. Replace damaged bolts. SEE FIGURE 5.

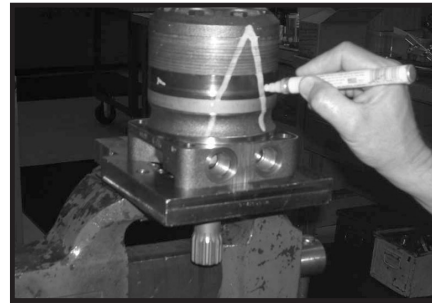

Figure 2

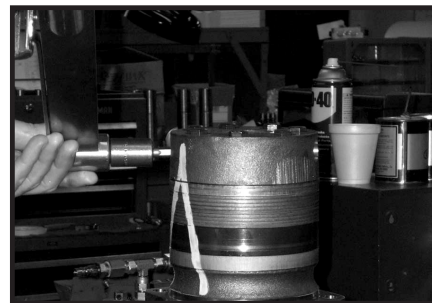

Figure 3

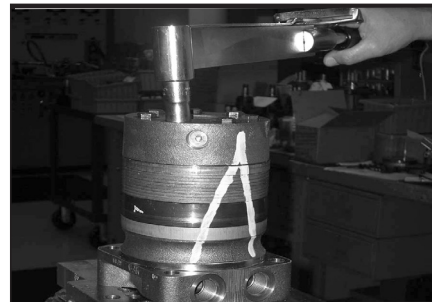

Figure 4



Figure 5

Remove end cover & inspect bolts

4. Remove end cover assembly (2) and seal ring (4). Discard seal ring. SEE FIGURE 6.

NOTE

NOTE: Refer to the appropriate “alternate cover construction” on the exploded view to determine the end cover construction being serviced.



Figure 6

Remove plugs and valves

5. If the end cover (2) is equipped with shuttle valve or relief valve (24) components, remove the two previously loosened plugs (21) and o-rings (22). SEE FIGURE 7.

CAUTION

CAUTION: Be ready to catch the shuttle valve or relief valve components that will fall out of the end cover valve cavity when the plugs are removed.

NOTE

NOTE: O-ring (22) is not included in seal kits but serviced separately if required.

NOTE

NOTE: The insert and if included the orifice plug in the end cover (2) must not be removed as they are serviced as an integral part of the end cover.

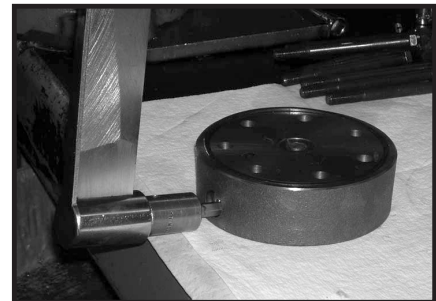

Figure 7

Wash & inspect end cover

6. Thoroughly wash end cover (2) in proper solvent and blow dry. Be sure the end cover valve apertures, including the internal orifice plug, are free of contamination. Inspect end cover for cracks and the bolt head recesses for good bolt head sealing surfaces. Replace end cover as necessary. SEE FIGURE 8.

NOTE

NOTE: A polished pattern (not scratches) on the cover from rotation of the commutator (5) is normal. Discoloration would indicate excess fluid temperature, thermal shock, or excess speed and require system investigation for cause and close inspection of end cover, commutator, manifold, and rotor set.

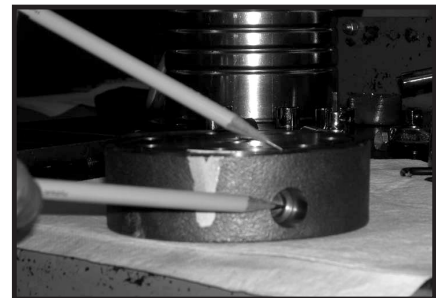

Figure 8

Remove & inspect commutator ring

7. Remove commutator ring (6). SEE FIGURE 9. Inspect commutator ring for cracks, or burrs.



Figure 9

76-238 DISASSEMBLY INSTRUCTIONS

Remove & inspect commutator

- Remove commutator (5) and seal ring (3). Remove seal ring from commutator, using an air hose to blow air into ring groove until seal ring is lifted out and discard seal ring. Inspect commutator for cracks or burrs, wear, scoring, spalling or brinelling. If any of these conditions exist, replace commutator and commutator ring as a matched set. SEE FIGURE 10 & 11.



Figure 10

Remove manifold

- Remove manifold (7) and inspect for cracks surface scoring, brinelling or spalling. Replace manifold if any of these conditions exist. SEE FIGURE 12. A polished pattern on the ground surface from commutator or rotor rotation is normal. Remove and discard the seal rings (4) that are on both sides of the manifold.



Figure 11

NOTE

NOTE: The manifold is constructed of plates bonded together to form an integral component not subject to further disassembly for service. Compare configuration of both sides of the manifold to ensure that same surface is reassembled against the rotor set.

Remove & inspect rotor set & wearplate

- Remove rotor set (8) and wearplate (9), together to retain the rotor set in its assembled form, maintaining the same rotor vane (8C) to stator (8B) contact surfaces. SEE FIGURE 13. The drive link (10) may come away from the coupling shaft (12) with the rotor set, and wearplate. You may have to shift the rotor set on the wearplate to work the drive link out of the rotor (8A) and wearplate. SEE FIGURE 14. Inspect the rotor set in its assembled form for nicks, scoring, or spalling on any surface and for broken or worn splines. If the rotor set component requires replacement, the complete rotor set must be replaced as it is a matched set. Inspect the wearplate for cracks, brinelling, or scoring. Discard seal ring (4) that is between the rotor set and wearplate.

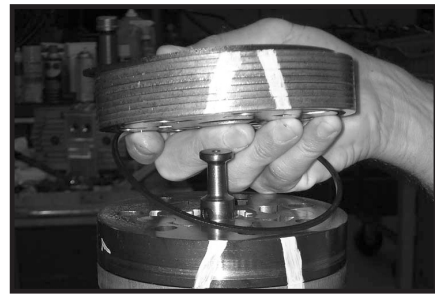

Figure 12

NOTE

NOTE: The rotor set (8) components may become disassembled during service procedures. Marking the surface of the rotor and stator that is facing UP, with etching ink or grease pencil before removal from Torqmotor™ will ensure correct reassembly of rotor into stator and rotor set into Torqmotor™. Marking all rotor components and mating spline components for exact repositioning at assembly will ensure maximum wear life and performance of rotor set and Torqmotor™.



Figure 13

NOTE **NOTE:** Series TG or TH may have a rotor set with two stator halves (8B & 8D) with a seal ring (4) between them and two sets of seven vanes (8C & 8E). Discard seal ring only if stator halves become disassembled during the service procedures.



Figure 14

NOTE **NOTE:** A polished pattern on the wear plate from rotor rotation is normal.

Check rotor, vane clearance

- Place rotor set (8) and wear plate (9) on a flat surface and center rotor (8A) in stator (8B) such that two rotor lobes (180 degrees apart) and a roller vane (8C) centerline are on the same stator centerline. Check the rotor lobe to roller vane clearance with a feeler gage at this common centerline. If there is more than .005 inches (0.13 mm) of clearance, replace rotor set. SEE FIGURE 15.

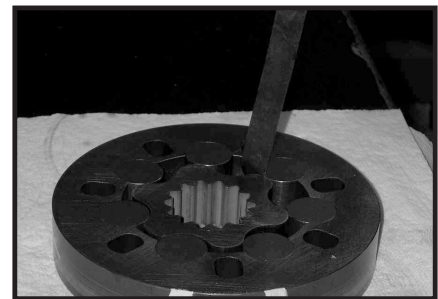

Figure 15

NOTE **NOTE:** If rotor set (8) has two stator halves (8B & 8D) and two sets of seven vanes (8C & 8E) as shown in the alternate construction TG rotor set assembly view, check the rotor lobe to roller vane clearance at both ends of rotor.

Remove & inspect drive link

- Remove drive link (10) from coupling shaft (12) if it was not removed with rotor set and wear plate. Inspect drive link for cracks and worn or damaged splines. No perceptible lash (play) should be noted between mating spline parts. SEE FIGURE 16. Remove and discard seal ring (4) from housing (18).



Figure 16

Remove thrust bearing

- Remove thrust bearing (11) from top of coupling shaft. Inspect for wear, brinelling, corrosion and a full complement of retained rollers. SEE FIGURE 17.

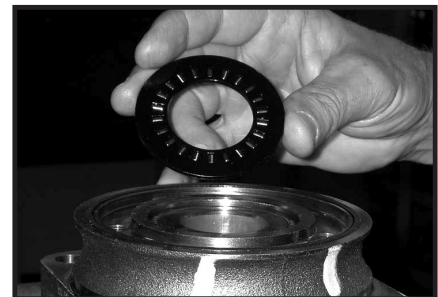

Figure 17

76-238 DISASSEMBLY INSTRUCTIONS

Check coupling shaft for rust or corrosion

14. Check exposed portion of coupling shaft (12) to be sure you have removed all signs of rust and corrosion which might prevent its withdrawal through the seal and bearing. Crocus cloth or fine emery paper may be used. SEE FIGURE 18. Remove any key (12A), nut (12B), washer (12C), bolt (12D), lock washer (12E), or retaining ring (12F).

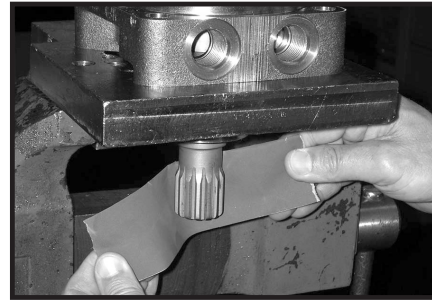

Figure 18

Remove & inspect coupling shaft

15. Remove coupling shaft (12), by pushing on the output end of shaft. SEE FIGURE 19. Inspect coupling shaft bearing and seal surfaces for spalling, nicks, grooves, severe wear or corrosion and discoloration. Inspect for damaged or worn internal and external splines or keyway. SEE FIGURE 20. Replace coupling shaft if any of these conditions exist.



Figure 19

NOTE

NOTE: Minor shaft wear in seal area is permissible. If wear exceeds .020 inches (0.51 mm) diametrically, replace coupling shaft.

NOTE

NOTE: A slight "polish" is permissible in the shaft bearing areas. Anything more would require coupling shaft replacement.

Remove seal ring from housing

16. Remove and discard seal ring (4) from housing (18).

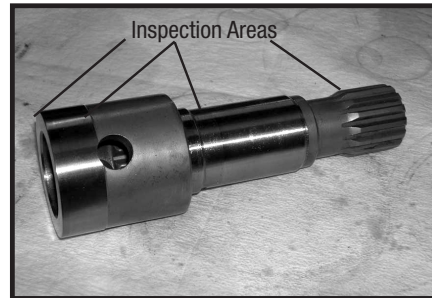

Figure 20

76-238 DISASSEMBLY INSTRUCTIONS

Remove shaft seal, backup washer & backup ring

17. Remove shaft seal (16), backup ring (17), and backup washer (25) from housing by working them around unseated thrust washers (14) and thrust bearing (15) and out of the housing. Discard seal and washers. SEE FIGURE 21.

NOTE

NOTE: The original design units of Torqmotors™ did not include backup washer (25), but must include backup washer (25) when reassembled for service.



Figure 21

Remove dirt & water seal

18. Remove housing (18) from vise, invert it and remove and discard dirt & water seal (20). A blind hole bearing or seal puller is required. SEE FIGURE 22.



Figure 22

Inspect housing assembly

19. Inspect housing (18) assembly for cracks, the machined surfaces for nicks, burrs, brinelling or corrosion. Remove burrs that can be removed without changing dimensional characteristics. Inspect tapped holes for thread damage. SEE FIGURE 23. If the housing is defective in these areas, discard the housing assembly.



Figure 23

76-238 DISASSEMBLY INSTRUCTIONS

Inspect housing bearing

20. If the housing (18) assembly has passed inspection to this point, inspect the housing bearings (19) and (13) and if they are captured in the housing cavity the two thrust washers (14) and thrust bearing (15). The bearing rollers must be firmly retained in the bearing cages, but must rotate and orbit freely. All rollers and thrust washers must be free of brinelling and corrosion. SEE FIGURE 24. A bearing, or thrust washer that does not pass inspection must be replaced. If the housing has passed this inspection the disassembly of the Torqmotor™ is completed.



Figure 24

NOTE

NOTE: The depth or location of bearing (13) in relation to the housing wear plate surface and the depth or location of bearing (19) in relation to the beginning of bearing counter bore should be measured and noted before removing the bearings. This will facilitate the correct reassembly of new bearings. SEE FIGURE 25.

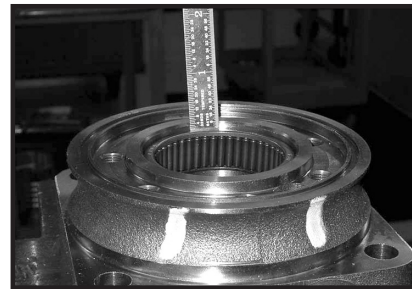

Figure 25

Remove bearings and thrust washers

21. If the bearings or thrust washers must be replaced use a suitable size bearing puller to remove bearing (19) and (13) from housing (18) without damaging the housing. Remove thrust washers (14) and thrust bearing (15) and inspect. SEE FIGURES 26 & 27.



Figure 26



Figure 27

THE DISASSEMBLY OF TORQMOTOR™ IS COMPLETED.

- Replace all seals and seal rings with new ones each time you reassemble the Torqmotor™ unit. Lubricate all seals and seal rings with SAE 10W40 oil or clean grease before assembly.
- **NOTE: Individual seals and seal rings as well as a complete seal kit are available. SEE FIGURE 28. The parts should be available through most OEM parts distributors or Parker approved Torqmotor™ distributors. (Contact your local dealer for availability).**
- **NOTE: Unless otherwise indicated, do not oil or grease parts before assembly.**
- Wash all parts in clean petroleum-based solvents before assembly. Blow them dry with compressed air. Remove any paint chips from mating surfaces of the end cover, commutator set, manifold rotor set, wear plate and housing and from port and sealing areas.

WARNING

WARNING: SINCE THEY ARE FLAMMABLE, BE EXTREMELY CAREFUL WHEN USING ANY SOLVENT. EVEN A SMALL EXPLOSION OR FIRE COULD CAUSE INJURY OR DEATH.

WARNING

WARNING: WEAR EYE PROTECTION AND BE SURE TO COMPLY WITH OSHA OR OTHER MAXIMUM AIR PRESSURE REQUIREMENTS.

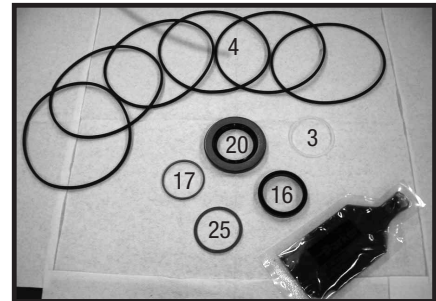

Figure 28

Place housing into soft-jawed vise

1. Clamp the housing into a soft-jawed vise or similar support with the coupling shaft bore down, clamping against the mounting flange.

Press in outer bearing

2. If the housing (18) bearing components were removed for replacement, thoroughly coat and pack a **new** outer bearing (19) with clean corrosion resistant grease recommended in the material section. Press the new bearing into the counterbore at the mounting flange end of the housing, using the appropriate sized bearing mandrel such as described in figure 1 or figure 2 which will control the bearing depth.

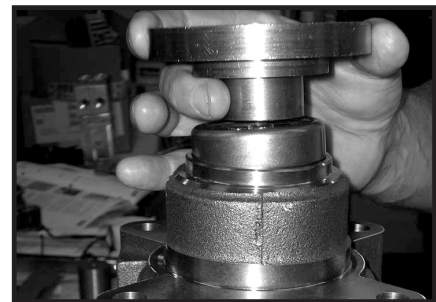

Figure 29

Torqmotor™ housings require the use of the bearing mandrel shown in figure 2 to press bearing (19) into the housing to a required depth of .290/.310 inches (7.37/7.87 mm) from the outside end of the bearing counterbore. SEE FIGURE 29.

Series TH Torqmotor housings require the use of a bearing mandrel. Consult factory for specifications.

76-238 ASSEMBLY INSTRUCTIONS

NOTE **NOTE:** Bearing mandrel must be pressed against the lettered end of bearing shell. Take care that the housing bore is square with the press base and the bearing is not cocked when pressing a bearing into the housing.

CAUTION **CAUTION:** If the bearing mandrel specified in the “Tools and Materials Required for Servicing” section is not available and alternate methods are used to press in bearing (13) and (19) the bearing depths specified must be achieved to insure adequate bearing support and correct relationship to adjacent components when assembled.

CAUTION **CAUTION:** Because the bearing (13) and (19) have a press fit into the housing they must be discarded when removed. They must not be reused.

- Press in dirt & water seal**
3. Press a **new** dirt and water seal (20) into the housing (18) outer bearing counterbore.
- The dirt and water seal (20) must be pressed in with the lip facing out and until the seal is flush to .020 inches (.51 mm) below the end of housing. SEE FIGURE 30.



Figure 30

Place housing assembly into vise

4. Invert housing (18) assembly into a soft jawed vise with the coupling shaft bore down, clamping against the mounting flange. SEE FIGURE 31.

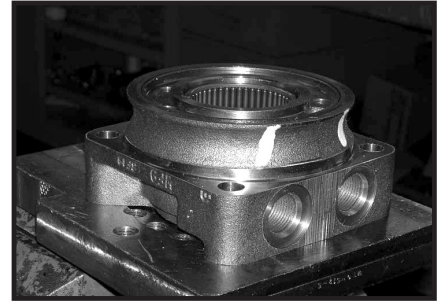

Figure 31

Press in inner bearing

5. The Torqmotor™ housing (18) requires that you assemble a **new** backup ring (17), **new** backup washer (25) & a **new** shaft seal (16), with the lip facing to the inside of Torqmotor (see figure 69A), thrust washer (14), thrust bearing (15) and a second thrust washer (14) in that order before pressing in the inner housing bearing (13). SEE FIGURE 32 & 33. When these components are in place, press **new** bearing (13) into the housing (18) to a depth of .105/.125 inches (2.67/3.18) below the housing wear plate contact face. Use the opposite end of the bearing mandrel used to press in outer bearing (19). Reference figure 2, in the “Tools and Materials Required for Servicing” section. SEE FIGURE 34.



Figure 32



Figure 33



Figure 34

76-238 ASSEMBLY INSTRUCTIONS

Assemble backup washer & seal 6. A housing (18) that did not require replacement of the bearing package will require that the two “captured” thrust washers (14) and thrust bearing (15) be unseated and vertical to the counterbore and the **new** backup ring (17), **new** backup washer (25), and **new** seal (16) be worked around the thrust bearing package and placed into their respective counterbores. The seal lip must face out of the seal counterbore and toward the inside of Torqmotor™ (see figure 60). Be sure the thrust bearing package is resealed correctly after assembly of the seal and backup washer. SEE FIGURES 35 & 36.

CAUTION

CAUTION: Original design TF & TG Torqmotors™ that do not have backup washer (25) when disassembled must be assembled with a new backup ring (17), new backup washer (25), and new seal (16).



Figure 35

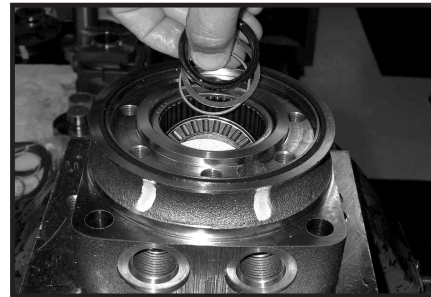

Figure 36

Apply masking tape to shaft 7. Apply masking tape around splines or keyway on shaft (12) to prevent damage to seal. SEE FIGURE 37.

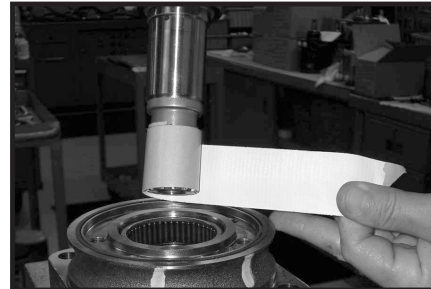

Figure 37

Install coupling shaft

8. Be sure that a generous amount of clean corrosion resistant grease has been applied to the lower (outer) housing bearing (19). Install the coupling shaft (12) into housing (18), seating it against the second thrust washer (14). SEE FIGURE 38.

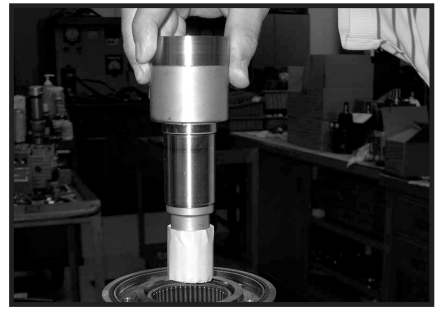

Figure 38

CAUTION

CAUTION: The outer bearing (19) is not lubricated by the system's hydraulic fluid. Be sure it is thoroughly packed with the recommended grease, Parker Gear grease specification #045236, E/M Lubricant #K-70M.

NOTE

NOTE: Mobil Mobilith SHC® 460
NOTE: A 102 Tube (P/N 406010) is included in each seal kit.

NOTE

NOTE: The coupling shaft (12) will be approximately .10 inch (2.54 mm) below the housing wear plate surface to allow the assembly of thrust bearing (11). The coupling shaft must rotate smoothly on the thrust bearing package. SEE FIGURE 39.



Figure 39

Install thrust bearing

9. Install thrust bearing (11) onto the end of coupling shaft (12) only if you are servicing. SEE FIGURE 40.



Figure 40

Insert seal ring

10. Apply a small amount of clean grease to a new seal ring (4) and insert it into the housing (18) seal ring groove. SEE FIGURE 41.



Figure 41

76-238 ASSEMBLY INSTRUCTIONS

- Install drive link** 11. Install drive link (10) the long splined end down into the coupling shaft (12) and engage the drive link splines into mesh with the coupling shaft splines. SEE FIGURE 42.

NOTE

NOTE: Use any alignment marks put on the coupling shaft and drive link before disassembly to assemble the drive link splines in their original position in the mating coupling shaft splines.



Figure 42

- Assemble wear plate and seal ring** 12. Assemble wear plate (9) over the drive link (10) and alignment studs onto the housing (18). SEE FIGURE 43.

Apply a small amount of clean grease to a new seal ring (4) and assemble it into the seal ring groove on the wear plate side of the rotor set stator (8B). SEE FIGURE 44.



Figure 43

- Install the assembled rotor set and seal ring** 13. Install the assembled rotor set (8) onto wear plate (9) with rotor (8A) counterbore and seal ring side down and the splines into mesh with the drive link splines. SEE FIGURE 45.

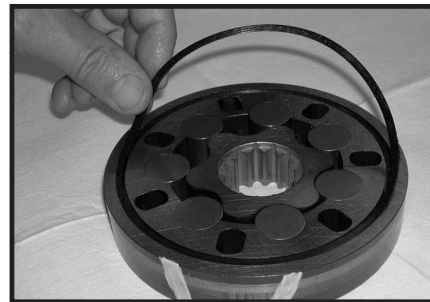

Figure 44

NOTE

NOTE: If necessary, go to the appropriate, "Rotor Set Component Assembly Procedure."

NOTE

NOTE: The rotor set rotor counterbore side must be down against wear plate for drive link clearance and to maintain the original rotor-drive link spline contact. A rotor set without a counterbore and that was not etched before disassembly can be reinstalled using the drive link spline pattern on the rotor splines if apparent, to determine which side was down. The rotor set seal ring groove faces toward the wear plate (9).



Figure 45

Apply clean grease to a **new** seal ring (4) and assemble it in the seal ring groove in the rotor set contact side of manifold (7). SEE FIGURE 46.

NOTE

NOTE: The manifold (7) is made up of several plates bonded together permanently to form an integral component. The manifold surface that must contact the rotor set has it's series of irregular shaped cavities on the largest circumference or circle around the inside diameter. The polished impression left on the manifold by the rotor set is another indication of which surface must contact the rotor set.

Install manifold and seal ring

14. Assemble the manifold (7) over the drive link (10) and onto the rotor set. Be sure the correct manifold surface is against the rotor set. SEE FIGURE 47.

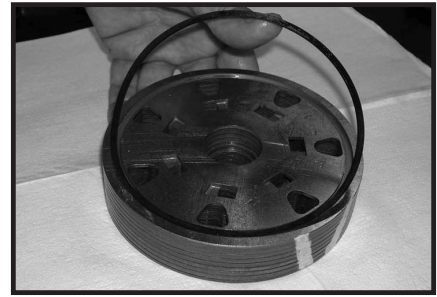

Figure 46



Figure 47

Apply grease to a **new** seal ring (4) and insert it in the seal ring groove exposed on the manifold. SEE FIGURE 48.



Figure 48

Install commutator ring

15. Assemble the commutator ring (6) onto the manifold. SEE FIGURE 49.

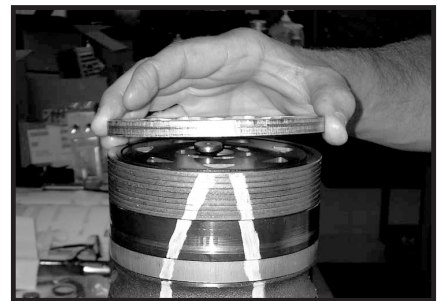

Figure 49

76-238 ASSEMBLY INSTRUCTIONS

- Assemble seal & commutator**
16. Assemble a **new** seal ring (3) flat side up, into commutator (5) and assemble commutator over the end of drive link (10) onto manifold (7) with seal ring side up. SEE FIGURES 50 and 51.



Figure 50

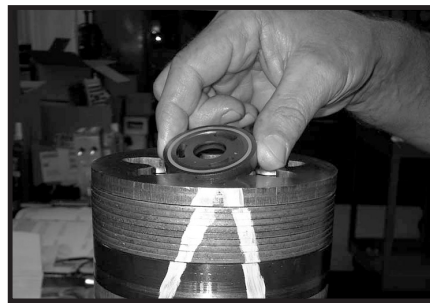

Figure 51

- Assemble shuttle valve parts into end cover**
17. If shuttle valve components items #21, #22, #23, #24 were removed from the end cover (2) turn a plug (21) with a **new** o-ring (22), loosely into one end of the valve cavity in the end cover. Insert a spring (23) the valve (24) and the second spring (23) into the other end of the valve cavity. Turn the second plug (21) with a **new** o-ring (22) loosely into the end cover valve cavity. 3/16 inch Allen wrench required. SEE FIGURE 52.

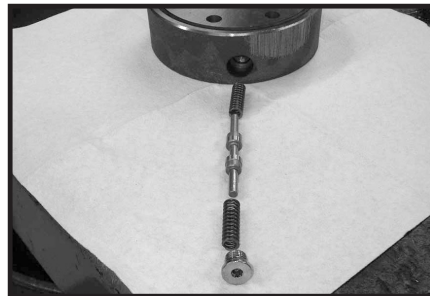

Figure 52

- Assemble relief valve parts in end cover**
18. If relief valve components items #21, #22, #24 were removed from the end cover (2) assemble a **new** o-ring (22) on the two plugs (21). Assemble a two piece relief valve (24) in each of the plugs, with the large end of the conical spring into the plug first and the small nut of the other valve piece in the small end of the conical spring. Turn each of the plug and relief valve assemblies into the end cover loosely to be torqued later. 3/8 inch Allen or 1 inch Hex socket required. SEE FIGURE 53.

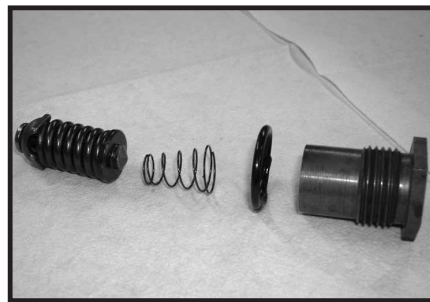

Figure 53

Assemble seal ring & end cover

19. Assemble a **new** seal ring (4) into end cover (2) and assemble end cover onto the commutator set. SEE FIGURES 54 and 55.

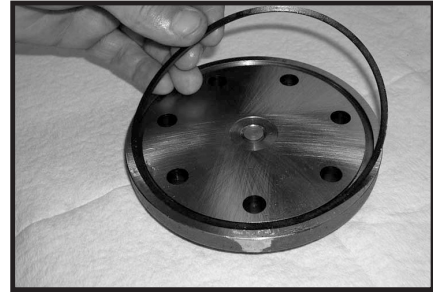

Figure 54

NOTE

NOTE: If the end cover has a valve (24), use the line you previously scribed on the cover to radially align the end cover into its original position.

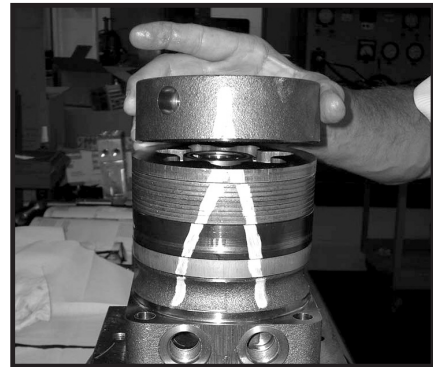

Figure 55

Assemble cover bolts

20. Assemble the 7 special bolts (1, 1A, 1B or 1C) and screw in finger tight. Alternately and progressively tighten the bolts to pull the end cover and other components into place with a final torque of 50-55 ft. lbs. (68-75 N m) for the seven 3/8-24 threaded bolts. SEE FIGURES 56, 57 and 58.

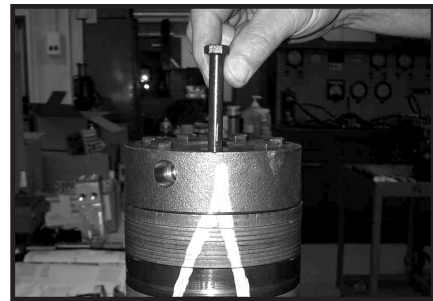

Figure 56

76-238 ASSEMBLY INSTRUCTIONS

NOTE

NOTE: The special bolts required for use with the relief or shuttle valve (24) end cover assembly (2) are longer than the bolts required with standard and cover assembly. Refer to the individual service parts lists or parts list charts for correct service part number if replacement is required.

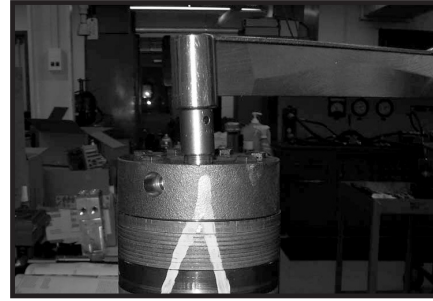

Figure 57

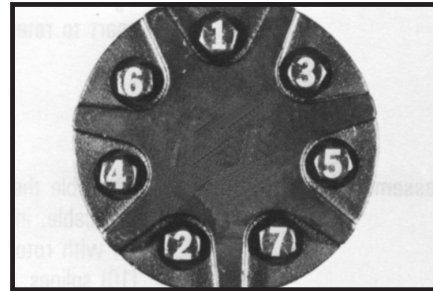

Figure 58

Torque the valve plugs

21. Torque the two shuttle valve plug assemblies (21) in end cover assembly to 9-12 ft. lbs. (12-16 N m) if cover is so equipped. SEE FIGURE 59.

Torque the two relief valve plug assemblies (21) in end cover assembly to 45-55 ft. lbs. (61-75 N m) if cover is so equipped.

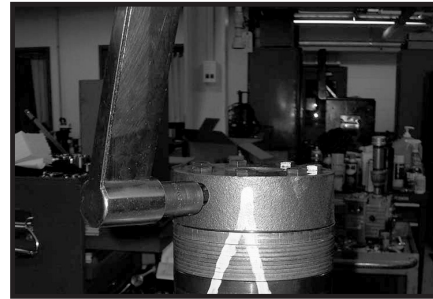

Figure 59

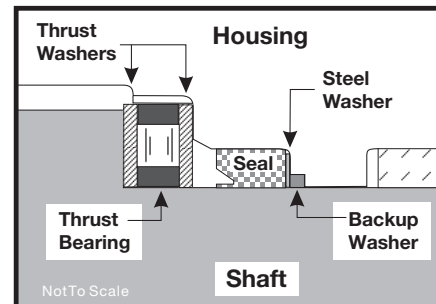

Figure 60

THE ASSEMBLY OF THE TORQMOTOR™ IS NOW COMPLETE EXCEPT FOR WOODRUFF KEY (12A), NUT (12B), WASHER (12C), BOLT (12D), LOCKWASHER (12E), RETAINER RING (12F) or PORT O-RINGS (18A) AT INSTALLATION IF APPLICABLE. PROCEED TO FINAL CHECKS SECTION.

Final Checks

- Pressurize the Torqmotor™ with 100 p.s.i. dry air or nitrogen and submerge in solvent to check for external leaks.
- Check Torqmotor™ for rotation. Torque required to rotate coupling shaft should not be more than 50 ft. lbs. (68 N m)
- Pressure port with “B” cast under it on housing (18) is for clockwise coupling shaft rotation as viewed from the output end of coupling shaft. Pressure port with “A” case under it is for counter clockwise coupling shaft rotation.
- Use test stand if available, to check operation of the Torqmotor™.

Hydraulic Fluid

Keep the hydraulic system filled with one of the following:

- 10W40 SE or SF manufacturers suggested oil.
- Hydraulic fluid as recommended by equipment manufacturer, but the viscosity should not drop below 50 SSU or contain less than .125% zinc anti-wear additives.

CAUTION: Do not mix oil types. Any mixture, or an unapproved oil, could deteriorate the seals. Maintain the proper fluid level in the reservoir. When changing fluid, completely drain old oil from the system. It is suggested also that you flush the system with clean oil.

Filtration

Recommended filtration 40-50 micron.

Oil Temperature

Maximum operating temperature 200°F (93.3° C).

48-258 3-BANK HYDRAULIC VALVE

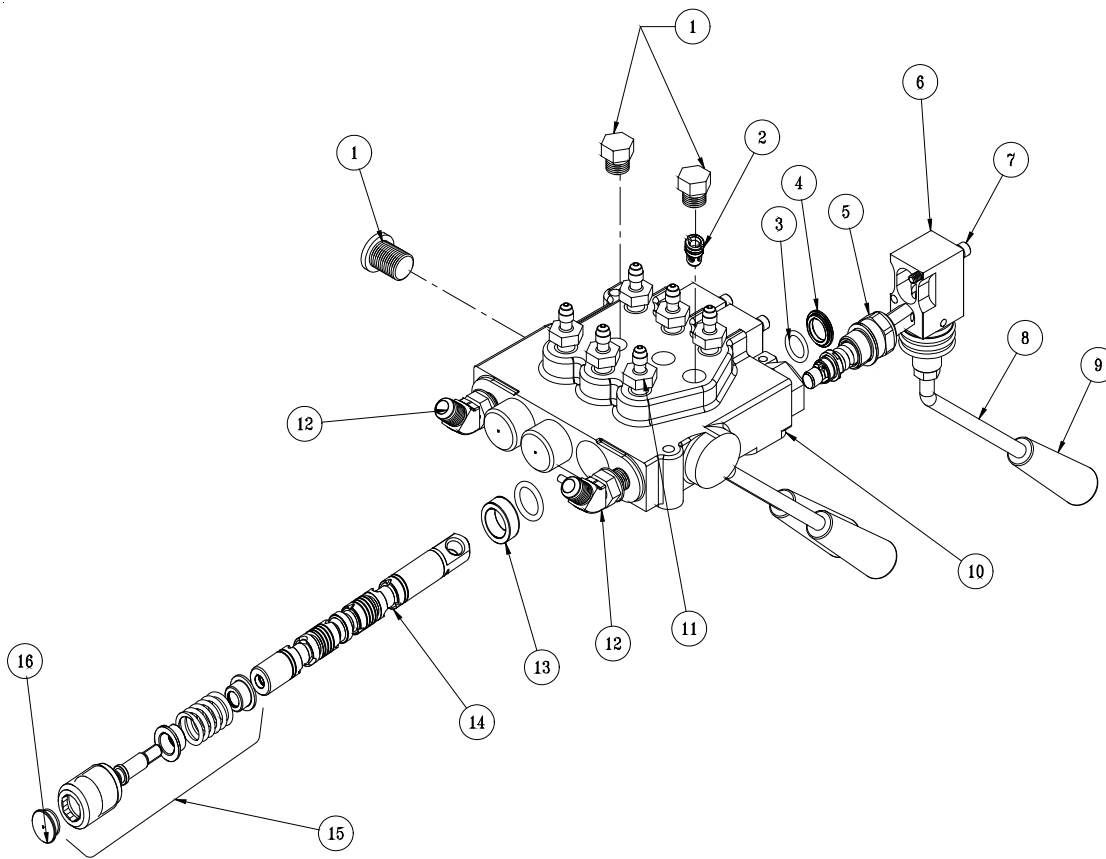

Parts

REF#	PART#	DESCRIPTION	QUANTITY
1*	78-415-13	³ / ₄ - 16 SAE 8 Screw Plug	3
2*	78-415-12	Check Valve Assembly HDM12	1
3*	78-415-03	O-Ring Seal	6
4*	78-415-04	Flanged Washer HDM10	3
5*	78-415-02	Spool HDM10	1
6*	78-415-09	Lever Group HDS11	3
7*	78-415-10	Metric Socket Screw M5 x .8 x 45	6
8	78-418	Bent Handle	3
9		Tapered Knob	3
10*	48-258-01	Body (complete with spacer and check valve)	1
11	18-169	Straight Thread Connectors	6
12	18-188	Straight Thread 45° Elbow	2
13*	78-415-05	Spacer	3
14*	78-415-06	A Type Spool HDS11	3
15*	78-415-11	Positioner HDM10	3
16*	78-415-08	Plug	3

* 48-258 3 – Bank Hydraulic Valve (includes all * items)

48-501 HOPPER DUST SHIELD

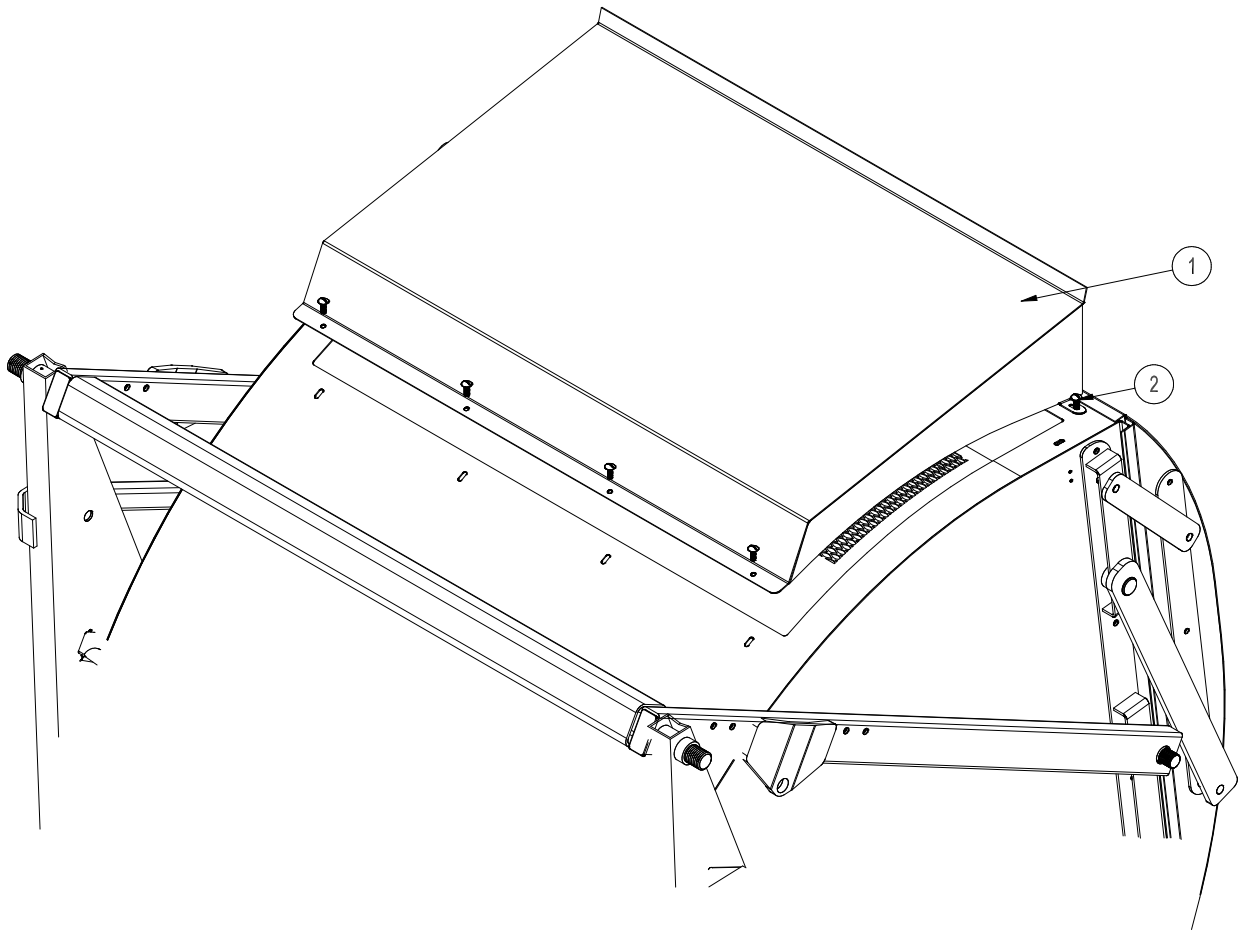

REF#	PART#	DESCRIPTION	QUANTITY
1	48-320	Hopper Dust Cover	1
2	HSTP-516-18-075	Phillips Machine Screw, $\frac{5}{16}$ - 18 x $\frac{3}{4}$	6
	HNFL-516-18	Flange Whiz-loc Nut, $\frac{5}{16}$ - 18	6

ACCESSORY

NOTES

DECAL LIST

This is a list of decals on the Sweep Star 48. Part number, description, and location will help in reordering decals.

16-088 Decal, Moving Parts/Hot	Belt Guard
25-286 Decal, Pinch Point	Front Hopper R & L Sides
25-307 Decal, Gasoline	Tank Cover Panel
25-320 Decal, Max Weight	Front Hopper Sides
25-358 Decal, Smithco 12"	Tailgate
25-362 Decal, Danger Fire	Tank Cover Panel
25-372 Decal, Smithco Star 4"	Belt Guard
27-077 Decal, Smithco Round	Steering Cap
27-093 Decal, Hydraulic Oil	Tank Cover Panel
34-147 Decal, Smithco Star	Nose Cone
48-145 Decal, Sweep Star 48 H	Hopper Sides
48-245 Decal, Dash Panel	Dashboard
48-261 Decal, Control Panel	Control Panel
76-307 Decal, Tower Warning	Tower Sides
75-651 Decal, Hopper Lift Safety Bar	Lift Bars on Hopper Sides
25-277 Decal, Battery	Inside Battery Cover
25-356 Decal, Tire Pressure (20 psi)	All Wheels
25-375 Decal, 94 dBA	Engine Cover

QUICK REFERENCE REPLACEMENT PARTS

REPLACEMENT FILTERS

20-576-01	Hydraulic Oil Filter	
13-531	Engine Oil Filter	
15-165-01	Air Filter Element with Pre-Cleaner	
42-076-03	Remote Air Filter Element	
42-834-03	Remote Safety Filter	
50-403	Fuel Filter	
18-462	Oil Drain Valve	Briggs & Stratton 25 755 14-S

REPLACEMENT BELTS

48-259	Finger Reel Belt
--------	------------------

SEAL KITS

42-258	3-Bank Hydraulic Valve
14-096	O-Ring Seal Kit

48-267	Hydrostatic Pump
77-239-23	Seal Kit

48-266	Gear Pump
76-197-08	Seal Kit

76-238	Wheel Motor
14-080	Seal Kit

76-627	Hydraulic Cylinder
76-242-01	Seal Kit

10-554	Hydraulic Cylinder
14-529	Seal Kit

76-478	Hydraulic Cylinder
14-531	Seal Kit

FLUIDS

Engine Oil	SJ or Higher 10W-30
Hydraulic Fluid	SJ or Higher 10W-40

OTHER PARTS

13-488	Key Switch	
	Spark Plugs	Champion® type RC 12YC or Equivalent Gap 0.030 (.76 mm) Torque 18/22 ft. lbs (24/30 Nm)
76-354	2 ¹ / ₂ # ABC Dry Chemical Fire Extinguisher	

DUST AND FILTRATION FILTERS

48-326	Hopper Filter
48-325	Tailgate Filter

The Smithco Commercial Products Two-Year Limited Warranty

Smithco, Inc. (Smithco) warrants your 2016 or newer Smithco Commercial Product (“Product”) purchased after October 1, 2016 to be free from defects in materials or workmanship for the period of time listed below. Where a warrantable condition exists, Smithco will repair the Product at no cost to you including diagnosis, labor (at the Smithco standard labor rate, subject to the Smithco flat rate schedule), and parts.

Warranty Duration is:

- (1) Two years, 1500 operational hours* from the date of delivery to the original purchaser or Five years from the date of original manufacturer of the product, whichever occurs first. (*Products equipped with hour meter).
- (2) Products used in rental situations are covered for 90 days from date of delivery to original user/renter.

Owner Responsibilities:

As the Product owner, you are responsible for required maintenance and adjustments stated in your Owner’s Manual. Failure to perform required maintenance and adjustments can be grounds for disallowing a warranty claim. **You are particularly responsible to train all present and future operators of this product on the safe operation of this product at your location.**

Instructions for Obtaining Warranty Service:

You are responsible for notifying the Authorized Smithco Products Distributor from whom you purchased the Product as soon as you believe a warrantable condition exists and not later than 30 days from discovery of the condition.

If you need help locating an Authorized Smithco Distributor, or if you have questions regarding your warranty rights or responsibilities, you may contact us at:

Smithco Product Support Department
200 West Poplar Ave.
Cameron, Wisconsin 54822
Telephone: 800-891-9435 E-Mail: ProductSupport@Smithco.com

Maintenance Parts:

Parts scheduled for replacement as required maintenance (“Maintenance Parts”), are warranted for the period of time up to the scheduled replacement time for that part.

Items/Conditions Not Covered:

Not all product failures or malfunctions that occur during the warranty period are defects in materials or workmanship. The items/conditions listed below are not covered by this warranty:



Product failures which result from the use of non-Smithco replacement parts, or from installation and use of add-on, modified, or unapproved accessories are not covered.



Product failures which result from failure to perform required maintenance and/or adjustments are not covered.



Product failures that result from operating the Product in an abusive, negligent or reckless manner are not covered.



This warranty does not apply to parts subject to consumption through use, unless found to be defective. Examples of parts which are consumed, or used up, during normal Product operation include, but are not limited to: blades, tines, teeth, scarifiers, rakes, plates, wear plates, castor wheels, tires, batteries, filters, belts, nozzles, etc.



This warranty does not apply to failures caused by outside influence. Items considered to be outside influence include, but are not limited to, weather, storage practices, contamination, use of unapproved coolants, lubricants, additives, or chemicals, etc.



This warranty does not apply to normal “wear and tear” items. Normal “Wear and Tear” includes, but is not limited to, damage to seats due to wear or abrasion, worn painted surfaces, scratched decals or windows, etc.



Smithco may require the return of failed parts or components in order to determine the validity of any warranty claim.



Smithco will not be obligated to replace components of other manufacturers if inspection by the original component manufacturer indicates that failure was due to normal wear and tear, expected consumption through use or improper care or service.

Other Legal Disclaimers:

The above remedy for product defects through repair or replacement by an authorized Smithco distributor or dealer is the purchaser’s sole remedy for any defect. This warranty gives you specific legal rights, and you may also have other rights which vary from state to state.

THERE ARE NO OTHER EXPRESS WARRANTIES OTHER THAN THOSE SET FORTH ABOVE. ALL IMPLIED WARRANTIES OF MERCHANTABILITY AND FITNESS FOR USE ARE LIMITED TO THE DURATION OF THE LIMITED WARRANTIES CONTAINED HEREIN.

Some states may not allow limitations on how long an implied warranty lasts, so the above limitation may not apply to you.

THE SMITHCO COMPANY IS NOT LIABLE FOR INDIRECT, INCIDENTAL OR CONSEQUENTIAL DAMAGES IN CONNECTION WITH THE USE OF THE PRODUCT, INCLUDING ANY COST OR EXPENSE OF PROVIDING A SUBSTITUTE PRODUCT OR SERVICE DURING PERIODS OF MALFUNCTION OR NON-USE.

Some states may not allow the exclusion of indirect, incidental or consequential damages, so the above exclusion may not apply to you.

Smithco neither assumes, nor authorizes any person to assume for it, any other liability in connection with the sale or use of this product.

