

Parts & Service



SweepStar 60
Gas and Diesel
76-000-D and 77-100-C
SN: 2574

May 2019

Product Support:

Hwy 55 & Poplar Ave; Cameron WI 54822
1-800-891-9435 productsupport@smithco.com

CONTENTS

Introduction

Introduction	1-3
Safe Practices	2
Specifications	3
Optional Equipment	3

Service

Service	4-11
Maintenance	4-6
Service Chart	7-8
End User's Service Chart	9-10
Adjustments	11
Storage	11

Diagrams

Diagrams	12-17
Diesel Wiring Diagram	12-13
Gas Wiring Diagram	14-15
Hydraulic Diagram	16-17

Parts

Parts	18-71
Body and Frame	18-19
Roll Over Protection (ROPS)	20-21
Steering	22-23
Front Fork	24-25
Gasoline Linkage	26-27
Diesel Linkage	28-29
Gas Console	30-31
Diesel Console	32-33
Gas Tank and Oil Tank	34-35
Fuel Tank and Oil Tank	36-37
Oil Filter	38-39
Hydraulic Lift Cylinder	38-39
Reel Lift Cylinder	40-41
Tailgate Cylinder	40-41
Vanguard Gas Engine and Exhaust	42-43
Kubota Diesel Engine and Exhaust	44-47
Electric Clutch Driven Belt Drive	48-49
Finger/Brush Reel	50-51
Rear Axle	52-55
Hopper	56-59
Tailgate	60-61
77-264 Eaton Hydrostatic Pump (Diesel)	62-63
76-482 Eaton Hydrostatic Pump (Gas)	64-65
76-197 Eaton Gear Pump	66-67
76-238 Rear Wheel Motor	68-69
76-023 3-Bank Hydraulic Valve	70-71

Accessories

Accessories	72-74
76-271 Dust/Dirt Filtration Pack	72-73
76-488 French Brush Reel	74

Reference

Reference	75-76
Decal List	75
Quick Reference Replacement Parts	76

Thank you for purchasing a **Smithco** product.

Read this manual and all other manuals pertaining to the Sweep Star 60 carefully as they contain safety, operating, assembly and maintenance instructions. Failure to do so could result in personal injury or equipment damage.

Keep manuals in a safe place after operator and maintenance personnel have read them. Right and left sides are from the operator's seat, facing forward.

 **WARNING:**

Engine exhaust and some of its constituents are known to the State of California to cause cancer, birth defects, and other reproductive harm.
For more information visit www.PWarning.ca.gov

WARNING

Failure to follow cautious operating practices can result in serious injury to the operator or other persons. The owner must understand these instructions, and must allow only trained persons who understand these instructions to operate this vehicle.

All **Smithco** machines have a Serial Number and Model Number. Both numbers are needed when ordering parts. The serial number plate on the Sweep Star 60 is located on the left front main frame, in front of the engine. Refer to engine manual for placement of engine serial number.

For product and accessory information, help finding a dealer, or to register your product please contact us at www.Smithco.com.

Information needed when ordering replacement parts:

1. Model Number of machine
2. Serial Number of machine
3. Name and Part Number of part
4. Quantity of parts

For easy access record your Serial and Model numbers here.

SMITHCO WAYNE, PENNSYLVANIA 19087 USA 610-688-4009 Fax 610-688-6069			
SERIAL NO.	kW/hp	DATE OF MFG.	
<input type="text"/>	<input type="text"/>	<input type="text"/>	
MODEL NO.	lb/kg Empty	lb/kg Full	
<input type="text"/>	<input type="text"/>	<input type="text"/>	

SAFE PRACTICES

- It is your responsibility to read this manual and all publications associated with this machine (engine, accessories and attachments).
2. Never allow anyone to operate or service the machine or its attachments without proper training and instructions. Never allow minors to operate any equipment.
 3. Learn the proper use of the machine, the location and purpose of all the controls and gauges before you operate the equipment. Working with unfamiliar equipment can lead to accidents.
 4. Wear all the necessary protective clothing and personal safety devices to protect your head, eyes, ears, hands and feet. Operate the machine only in daylight or in good artificial light.
 5. Inspect the area where the equipment will be used. Beware of overhead obstructions and underground obstacles. Stay alert for hidden hazards.
 6. Never operate equipment that is not in perfect working order or without decals, guards, shields, or other protective devices in place.
 7. Never disconnect or bypass any switch.
 8. Carbon monoxide in the exhaust fumes can be fatal when inhaled, never operate a machine without proper ventilation.
 9. Fuel is highly flammable, handle with care.
 10. Keep engine clean. Allow the engine to cool before storing and always remove the ignition key.
 11. After engine has started, machine must not move. If movement is evident, the neutral mechanism is not adjusted correctly. Shut engine off and readjust so the machine does not move when in neutral position.
 13. Never use your hands to search for oil leaks. Hydraulic fluid under pressure can penetrate the skin and cause serious injury.
 14. This machine demands your attention. To prevent loss of control or tipping of the vehicle:
 - A. Use extra caution in backing up the vehicle. Ensure area is clear.
 - B. Do not operate on a slope greater than 10°. Pay careful attention to the inclinometer on your machine.
 - C. Do not stop or start suddenly on sloped surfaces.
 - D. Reduce speed on slopes and in all turns. Use caution when changing directions on all surfaces.
 - E. Do not change directions of travel on any slope.
 - F. Do not operate debris hopper lift or tailgate while on slopes.
 - G. Stay alert for holes in the terrain and other hidden hazards.
 15. Before leaving operator's position for any reason:
 - A. Disengage all drives.
 - B. Lower all attachments to the ground.
 - C. Set park brake.
 - D. Shut engine off and remove the ignition key.
 16. Keep hands, feet and clothing away from moving parts. Wait for all movement to stop before you clean, adjust or service the machine.
 17. Keep the area of operation clear of all bystanders.
 18. Never carry passengers.
 19. Stop engine before making repairs/adjustments or checking/adding oil to the crankcase.
 20. Use parts and materials supplied by SMITHCO only. Do not modify any function or part.
 21. Do not remove the radiator cap when the engine is hot. When cooled, loosen cap slightly to the stop to relieve any pressure before removing the cap completely.

These machines are intended for operation by well trained persons performing professional maintenance on golf courses, sports turf, and any other area maintained turf and related trails, paths and lots. No guaranty as to the suitability for any task is expressed or implied.

SPECIFICATIONS FOR SWEEP STAR 60 GAS & DIESEL

WEIGHTS AND DIMENSIONS

Length	129" (328 cm)
Width	74.5" (179 cm)
Height with Hopper Down	82" (208 cm)
Height with Hopper Up	127" (323 cm)
Wheel Base	68.5" (174 cm)
Weight	2200 lbs (998 kg)

ROLL OVER PROTECTION BAR

Standard on all Machines

SOUND LEVEL

At ear level
At 3 ft (0.914 m)
At 30 ft (9.14 m)

GAS ENGINE

92 dB
86 dB
64 dB

DIESEL ENGINE

98 dB
96 dB
74 dB

ENGINE

Make
Model#
Type / Spec#
Horsepower
Fuel
Cooling System
Lubrication System
Alternator

GAS

Briggs & Stratton
543477
0175J1
31 Hp (23 kw)
Unleaded 87 Octane
Gasoline Minimum
Air Cooled
Full Pressure
24 Amp

DIESEL

Kubota
D 722 B1
19Hp (14 kw)
No. 2 Diesel
Liquid Cooled
Full Pressure
40 Amp

Tire & Wheels

Front: One 18 x 9.50 x 8 Multi-rib (20 psi; 1.4 bar)
Front tire and wheel fluid filled to 50 lbs. total. 28 pints of windshield washer fluid or equivalent.
Rear: Two 24 x 13.00 x 12 Super Soft (18 psi; 1.3 bar)
Castor: 9 x 3.5 - 4 (20 psi; 1.4 bar)

SPEED

Forward Speed	0 to 12 m.p.h. (0-19 kph)
Reverse Speed	0 to 4 m.p.h. (0-6 kph)

BATTERY

Automotive type 45 -12 volt	
BCI Group	Size 45
Cold Cranking Amps	480 minimum
Ground Terminal Polarity	Negative (-)
Maximum Length	9" (23 cm)
Maximum Width	5.38" (14 cm)
Maximum Height	9" (23 cm)

FLUID CAPACITY

Crankcase Oil	See Engine Manual	See Engine Manual
Fuel	6 gallon (22,7 liters)	5 gallon (19 liters)
Hydraulic Fluid	5 gallon (19 liters)	5 gallon (19 liters)
Cooling		Kubota approximately 1 gallon (3.8 liters)
Grade of Hydraulic Fluid	SAE 10W-40 API Service SJ or higher Motor Oil	

OPTIONAL EQUIPMENT

77-328	60" Brush Kit
76-329	60" Finger Reel Kit
76-271	Filtration Pack
77-218	Triple Castor Wheel Kit

MAINTENANCE

LUBRICATION

Use No. 2 General Purpose Lithium Base Grease and lubricate every 100 hours. The Sweep Star 60 has eleven grease fittings.

- A. One on the outside of each tower.
- B. One on hydrostatic forward and reverse relay.
- C. One on the center of park brake relay on rear axle.
- D. One on hydrostatic pedal under the floorboard.
- E. One on each castor wheel mount bracket.
- F. One on rear skid pivot.
- G. One on each pillow block bearing on end of finger reel.
- H. One on rod end of the tailgate cylinder.

Every 500 hours of operation, separate the hydrostatic pump from the engine. Clean the splined areas and lightly grease the male portion of the pump spline. Use either Dow Corning® G-N Metal Assembly Paste or #77 Assembly Paste (Kohler # 25 357 12-s).

As you remount the pump to the engine, be certain the mating surface are clean and free of any foreign material and that the pump is correctly aligned.

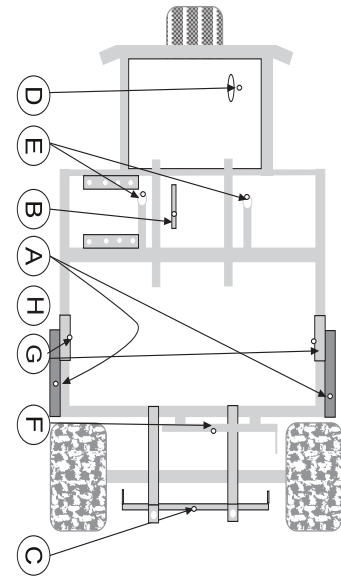

HYDRAULIC OIL

1. Use SAE 10W-40 API Service SJ or higher motor oil.
2. For proper warranty, change oil every 500 hours or annually, whichever is first and change the filter after the first 50 hours, then every 250 hours thereafter.
3. The oil level should be 2" to 2 1/2" from top of the tank when fluid is cold. Do not overfill.
4. After changing oil and/or filter, run the machine for a few minutes. Check oil level and for leaks.
5. Always use caution when filling hydraulic oil tank or checking level to keep system free of contaminants. Check and service more frequently when operating in extremely cold, hot or dusty conditions.
6. If natural color of fluid is now black or smells burnt, it is possible that an overheating problem exists.
7. If fluid becomes milky, water contamination may be a problem.
8. If either of the above conditions happen, change oil and filter immediately after fluid is cool and find cause. Take fluid level readings when system is cold.
9. In extreme temperatures you can use straight weight oil. We recommend SAE 30W API Service SJ or higher when hot (above 90°F (33°C)) and SAE 10W API Service SJ or higher when cold (below 32°F (0°C)) ambient temperature. Use either motor oil or hydraulic oil, but do not mix.
10. Oil being added to the system must be the same as what is already in the tank. Mark tank fill area as to which type you put in.

TIRE PRESSURE

Caution must be used when inflating a low tire to recommended pressure. Over inflating can cause tires to explode. Front tires and castor wheel should be 20 psi (1.4 bar), rear tires should be 18 psi (1.3 bar) maximum. Improper inflation will reduce tire life considerably.

ENGINE OIL

Change and add oil according to charts below. Do not overfill. Use a high quality detergent oil. **For Briggs engine** use oil classified "For Service SJ or higher" SAE 30 oil. **For Kubota Diesel engine** use oil classified "For Service CC, CD or CE" API oil. Use no special additives with recommended oils. Do not mix oil with gasoline. If the CF-4 or CG-4 lubrication oil is used with high-sulfur fuel, change the lubricating oil more often.

SAE 30 oil, if used below 40° F (4° C), will result in hard starting and possible engine bore damage due to inadequate lubrication.

The use of non-synthetic multi-viscosity oils in temperatures above 80°F (27° C) will result in higher than normal oil consumption. Check oil level more frequently when using a multi-viscosity oil.

SAE Viscosity Grades

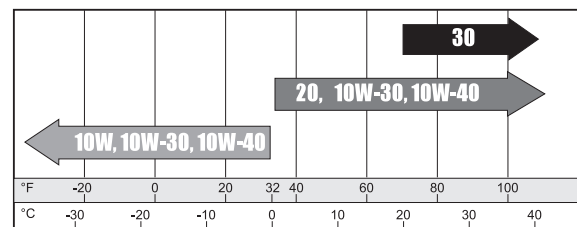
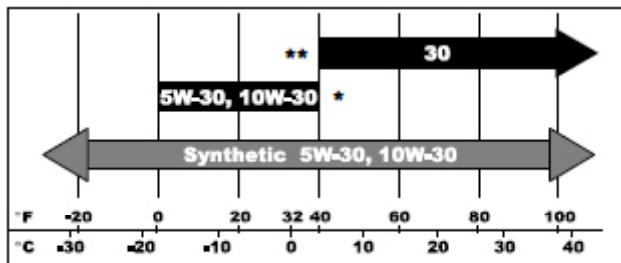

Starting Temperature Range Anticipated Before Next Oil Change

TOWING

When it is necessary to move the Sweep Star 60 without engine running, the bypass valve built into hydrostatic pump must be "open" by turning it counterclockwise. The valve is located on bottom left of pump. An "open" valve allows fluid to pass through the wheels freely. When normal, driven, operation is desired, valve should be closed by turning it clockwise. Failure to "close" the valve with engine running means no power to wheels.

BATTERY

Batteries normally produce explosive gases which can cause personal injury. Do not allow flames, sparks or any ignited object to come near the battery. When charging or working near battery, always shield your eyes and always provide proper ventilation.

Battery cable should be disconnected before using "Fast Charge".

Charge battery at 15 amps for 10 minutes or 7 amps for 30 minutes. Do not exceed the recommended charging rate. If electrolyte starts boiling over, decrease charging.

Always remove grounded (-) battery clamp first and replace it last. Avoid hazards by:

1. Filling batteries in well-ventilated areas.
2. Wear eye protection and rubber gloves.
3. Avoid breathing fumes when electrolyte is added.
4. Avoid spilling or dripping electrolyte.

⚠ WARNING

Battery Electrolyte is an acidic solution and should be handled with care. If electrolyte is splashed on any part of your body, flush all contact areas immediately with liberal amounts of water. Get medical attention immediately.

FILTER PACK

Filter pack may be cleaned by shaking or spraying off with low pressure water. Filter will disintegrate if high pressure is used on it.

MAINTENANCE (CONTINUED)

WHEEL MOUNTING PROCEDURE

REAR WHEELS

1. Set park brake. Turn machine off and remove key.
2. Block one of the other wheels.
3. Loosen nuts slightly on wheel to be removed.
4. Jack up machine being careful not to damage underside of machine.
5. Remove nuts, remove wheel.
5. Place new wheel on hub lining up bolt holes.
6. Torque nuts to 64-74 ft/lb (87-100 Nm) using a cross pattern. Torque again after first 8 hours and every 200 hours thereafter.
7. Lower machine to ground and remove blocks and jack.

FRONT WHEEL

1. Set park brake. Turn machine off and remove key.
2. Block one of the other wheels.
3. Remove cotter pins from each end of the axle.
4. Remove axle nuts, machine bushings and axle locks.
5. Jack up front of machine being careful not to damage underside of machine.
6. Wheel and axle will come out of slots in the u-bracket, pull wheel forward.
7. Place new wheel on hub lining up bolt holes.
8. Torque nuts to 64-74 ft/lb (87-100 Nm) using a cross pattern. Torque again after first 10 hours and every 200 hours thereafter.
9. Lower machine to ground and remove blocks and jack.

JUMP STARTING

⚠ WARNING

Use of booster battery and jumper cables. Particular care should be used when connecting a booster battery. Use proper polarity in order to prevent sparks.

To jump start (negative grounded battery):

1. Shield eyes.
2. Connect ends of one cable to positive (+) terminals of each battery, first (A) then (B).
3. Connect one end of other cable to negative (-) terminal of "good" battery (C).
4. Connect other end of cable (D) to engine block on unit being started (NOT to negative (-) terminal of battery)

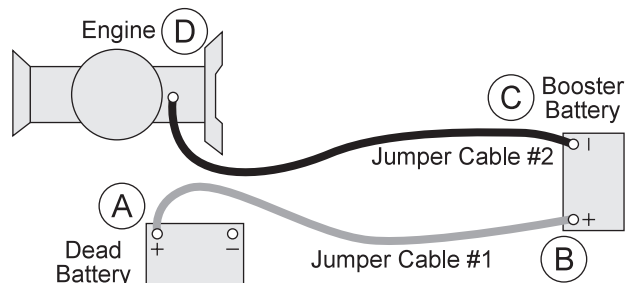

To prevent damage to other electrical components on unit being started, make certain that engine is at idle speed before disconnecting jumper cables.

SWEEPING

While sweeping close tailgate frequently to ensure tailgate does not creep open.

SERVICE CHART GAS

⚠ CAUTION

Before servicing or making adjustments to the machine, stop engine, set park break, block wheels and remove key from ignition.

⚠ IMPORTANT

Follow all procedures and **ONLY** use parts prescribed by the manufacturer. Read the engine manual before maintenance.

The suggested maintenance checklist is not offered as a replacement for the manufacturer's engine manual but as a supplement. You must adhere to the guidelines established by the manufacturer for warranty coverage. In adverse conditions such as dirt, mud or extreme temperatures, maintenance should be more frequent.

Maintenance Service Interval	Maintenance Procedure
After the first 8 operating hours	Torque the wheel lug nuts. (64-74 ft/lb (87-100 Nm))
	Change the engine oil filter.
Before each use daily	Check the engine oil level.
	Clean area around muffler and controls.
	Check the hydraulic fluid level.
	Check the tire pressure.
	Check and clean Debris Filter Pack1
	Check condition of hydraulic hoses and fittings.
	Inspect and clean the machine.
After the first 50 hours	Change Hydraulic Oil Filter.
Every 100 hours	Clean or change air filter.1&2
	Clean pre-cleaner.1
	Change engine oil and filter.
	Replace spark plug .
	Lubricate machine.
	Clean or change remote air cleaner.
	Check the battery fluid level and cable connections..
	Service exhaust system.
	Check belt tension .
Every 250 hours	Check engine valve clearance and adjust if necessary.
	Check idle speed.
	Clean battery terminals.
	Change hydraulic oil filter.
	Torque the wheel lug nuts. (64-74 ft/lb (87-100 Nm))
Every 500 hours or yearly	Change fuel filter.
	Change hydraulic oil and filter.
	Clean oil cooler fins.1
	Replace air filter2
	Replace fuel filter
	Clean air cooling system.1
	Check safety filter in remote air cleaner.
1 In dusty conditions or when airborne debris is present, clean more often.	
2 Every third air filter change, replace the inner safety filter.	

SERVICE CHART DIESEL

⚠ CAUTION

Before servicing or making adjustments to the machine, stop engine, set park break, blockwheels and remove key from ignition.

⚠ IMPORTANT

Follow all procedures and **ONLY** use parts prescribed by the manufacturer. Read the engine manual before maintenance.

The suggested maintenance checklist is not offered as a replacement for the manufacturer's engine manual but as a supplement. You must adhere to the guidelines established by the manufacturer for warranty coverage. In adverse conditions such as dirt, mud or extreme temperatures, maintenance should be more frequent.

Maintenance Service Interval	Maintenance Procedure
After the first 8 operating hours	Torque the wheel lug nuts. (64-74 ft/lb (87-100 Nm))
	Change the engine oil filter.
Before each use daily	Check the engine oil level.
	Clean area around muffler and controls.
	Check the hydraulic fluid level.
	Check the tire pressure.
	Check and clean Debris Filter Pack1
	Check condition of hydraulic hoses and fittings.
	Check for oil or water leaks.
	Proper function of glow lamp timer.
	Color of exhaust fumes.
Inspect and clean the machine.	
After the first 50 hours	Change Hydraulic Oil Filter.
	Change Engine oil and filter.
Every 100 hours	Clean or change air filter.1
	Clean pre-cleaner.1
	Change engine oil and filter.
	Replace spark plug .
	Lubricate machine.
	Clean or change remote air cleaner.
	Check the battery fluid level and cable connections..
Check belt tension .	
Every 200 hours	Check radiator hoses and clamp bands.
	Check idle speed.
	Replace oil filter cartridge.
	Change hydraulic oil filter.
	Check air intake line
	Torque the wheel lug nuts. (64-74 ft/lb (87-100 Nm))
Every 500 hours or yearly	Change fuel filter.
	Change hydraulic oil and filter.
	Clean oil cooler fins.1
	Clean air cooling system.1
	Change radiator coolant.

ADJUSTMENTS

PARK BRAKE ADJUSTMENT

By turning knob on end of park brake lever you can tighten or loosen brake a small amount. To tighten turn the knob clockwise. To loosen turn counter clockwise. If this is not enough turn clevis on brake cable to adjust length of cable.

STEERING CHAIN ADJUSTMENT

Steering Sprockets (A) should be level with each other. Check with straight edge. Make any adjustments. Slide Idler Pulley (B) so that it is snug onto the chain. Tighten all nuts and bolts in place.

WHEEL 'CREEP' ADJUSTMENT

'Creep' is when engine is running and hydrostatic transmission is in neutral, but due to inadequate alignment, wheels still move. Do the following procedures to stop this motion.

1. Lift up and support the unit so rear wheels are off the ground and can turn freely.
2. On the side of hydrostatic transmission is the Shift Arm (C). In the 'V' shaped notch of shift arm rests Idler Pulley (D). This Pulley is mounted on an Idler Arm (E).
3. Loosen bolt and nut holding Pulley to Idler Arm. Leave finger tight.
4. With engine running, slide the Pulley in Idler Arm slot until it centers on Shift Arm on hydrostatic and wheel 'creep' stops.
5. Tighten all fasteners and test by using foot pedal linkage to see that the 'creep' is removed.
6. Turn the engine off and lower the machine.

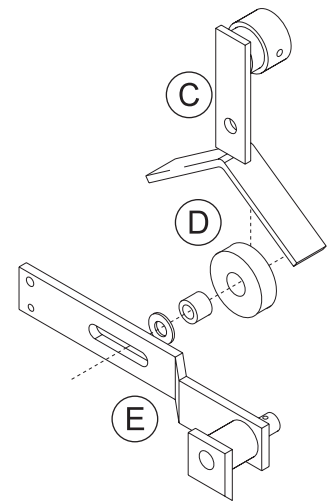
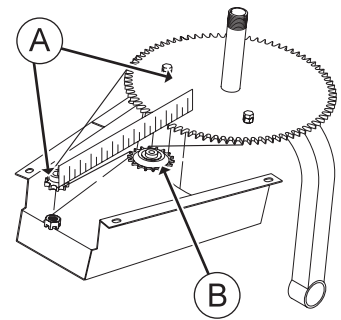

Service

STORAGE

When storing, remove the key from the key switch to avoid unauthorized persons from operating machine.

1. Before storing clean machine thoroughly.
2. Check bolts and nuts, tighten as necessary.
3. Make all repairs that are needed and remove any debris.
4. Remove the battery, adjust the electrolyte level and recharge it. Store the battery in a dry, dark place.
5. Store in a clean and dry area, but NOT near a stove, furnace or water heater which uses a pilot light or any device that can create a spark.
6. Engines stored over 30 days need to be protected or drained of fuel to prevent gum from forming in a fuel system or on essential carburetor parts. Check the engine manual and follow the instructions for the storage of the engine.

DIESEL WIRING DIAGRAM

Color Code Chart

Bl	Blue
Br	Brown
Y	Yellow
Grn	Green
O	Orange
R	Red
B	Black
P	Purple
W	White

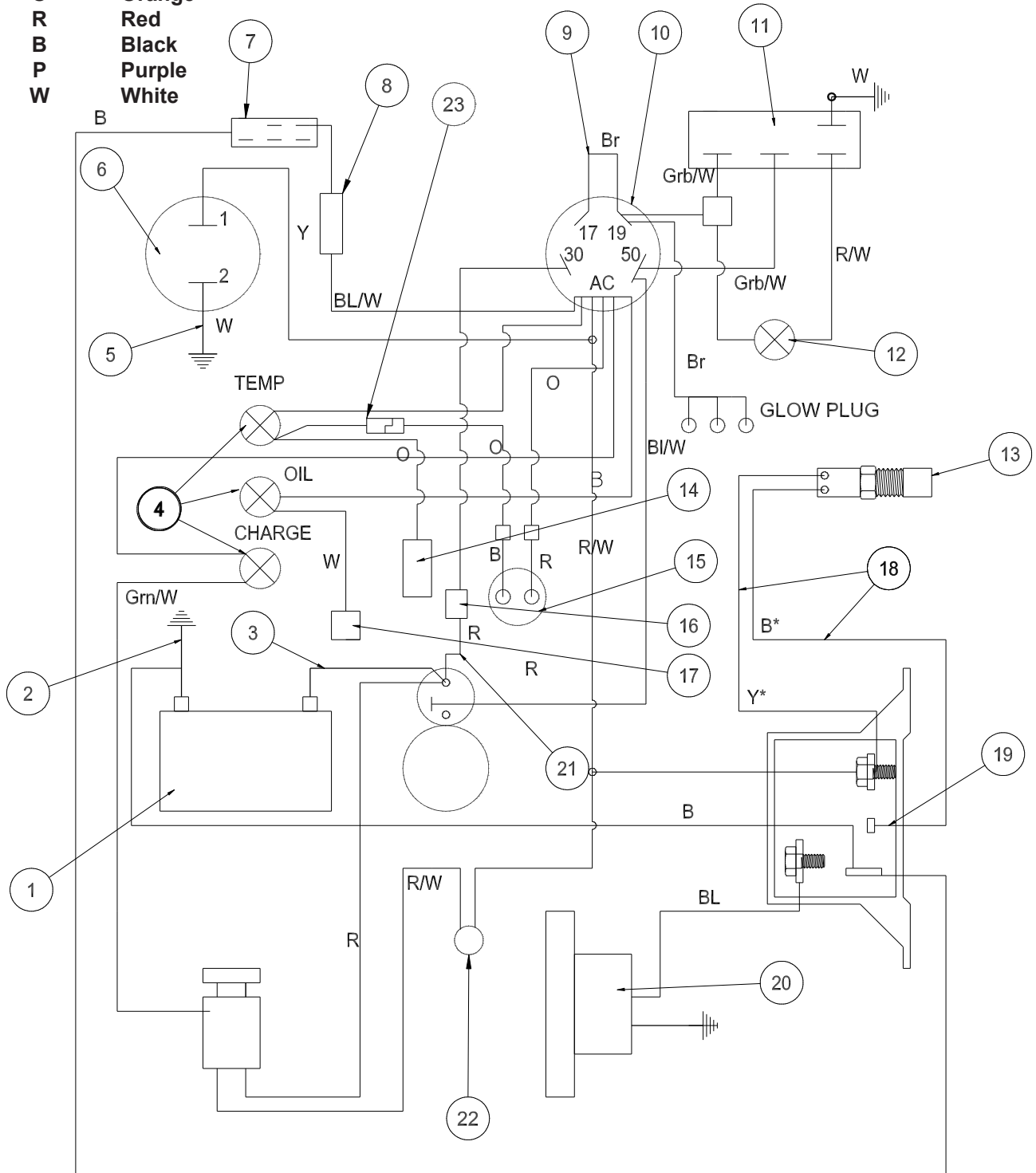

Diagrams

DIESEL WIRING PARTS LIST

REF#	PART#	DESCRIPTION	QUANTITY
1	22-073	Battery	1
	48-166	Battery Holddown	1
2	48-147	Black Battery Cable	1
3	48-157	Red Battery Cable	1
	8892-46.5	Hose Wrap 1/4 x 46.5	1
4	50-359	Warning Indicator Lights	3
5	77-209	Hour Meter to Ground Wire	1
6	12-804	Hour Meter	1
7	76-337	Electric Clutch	1
	17-271	Pigtail	1
8	15-314	Toggle Switch	1
	15-472	Boot	1
9	77-226	Wire 17 to 19 Ignition Switch	1
10	17-068	Key Switch	1
	17-079	Key Set	1
11	77-223	Glow Lamp Timer	1
12	50-359	Glow Plug Indicator Light	1
	8875	Bullet Terminal	1
	8874	Line Connector	1
	8963	Heat Shrink	2
13*	77-208-05	Air Pack Switch (part of engine)	1
14	77-208-01	Temperature Sender (part of engine)	1
15	77-207	Buzzer	1
16	77-261	40 Amp Circuit Breaker	1
	8977	Circuit Breaker Boot	1
17		Oil Sender (part of engine)	1
18*	77-234	Thermostat Wire Harness	1
19*	77-233	Bosch Power Relay	1
20	77-201	Electric Fan	1
	8844-9	Light Blue Wire	1
	8849-14	Black Wire	1
	8900-14	Flex Loom	1
	8854	Fork terminal	1
	8860	Butt Connector	2
	8933	Ring terminal	1
21	48-144	Circuit Breaker Wire	1
22	14-292	Seat Switch	1
23	9016	Weather Pack	1
	9017	Weather Pack Terminal	2
	9018	Seal	2
	77-262	Wire Harness (contains all wires except # 5 & 15)	1
*	77-235	Thermostat Kit	
	22-065	Auxillary Ground	1

GAS WIRING DIAGRAM

Color Code Chart

Bl	Blue
Br	Brown
Y	Yellow
Grn	Green
O	Orange
R	Red
B	Black
P	Purple
W	White

Diagrams

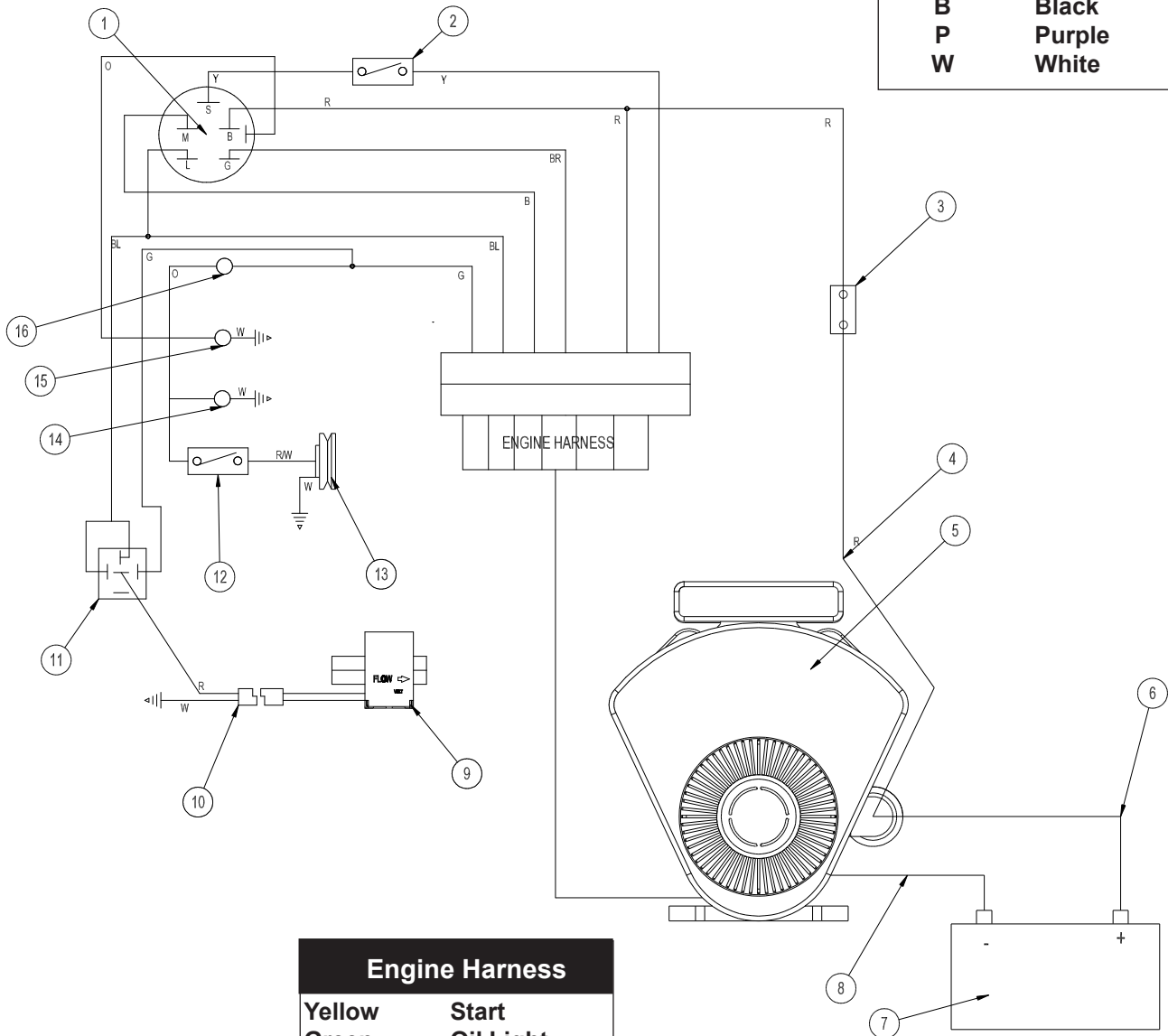

Engine Harness

Yellow	Start
Green	Oil Light
Brown	Ground
Red	Rectifier
Black	Magneto
Gray	Fuel Solenoid

GAS WIRING PARTS LIST

REF#	PART#	DESCRIPTION	QUANTITY
1	13-488	Key Switch with Hardware	1
2	14-292	Seat Switch	1
3	77-261	Circuit Breaker 40 AMP	1
	8977	Circuit Breaker Boot	1
4	48-144	Circuit Breaker Wire	1
5		Engine	1
6	48-157	Red Battery Cable	1
	8892-46.5	Hose Wrap 1/4 x 46.5	1
7	22-073	Battery	1
8	48-147	Black Battery Cable	1
9	76-471	Fuel Pump	1
	9016	Weather Pack Connector	1
	9017	Female Terminal	2
	9018	Seal	2
	9027	Terminal Tap	1
10	76-472	Fuel Pump Wire Harness	1
11	30-042-06	Relay	1
12	15-314	Toggle Switch	1
	15-472	Switch Boot	1
13	76-412	Electric Clutch	1
14	76-397	Voltmeter	1
15	12-804	Hour Meter	1
16	50-359	Warning Indicator Light	1
	76-394	Wire Harness	1

Diagrams

HYDRAULIC DIAGRAM

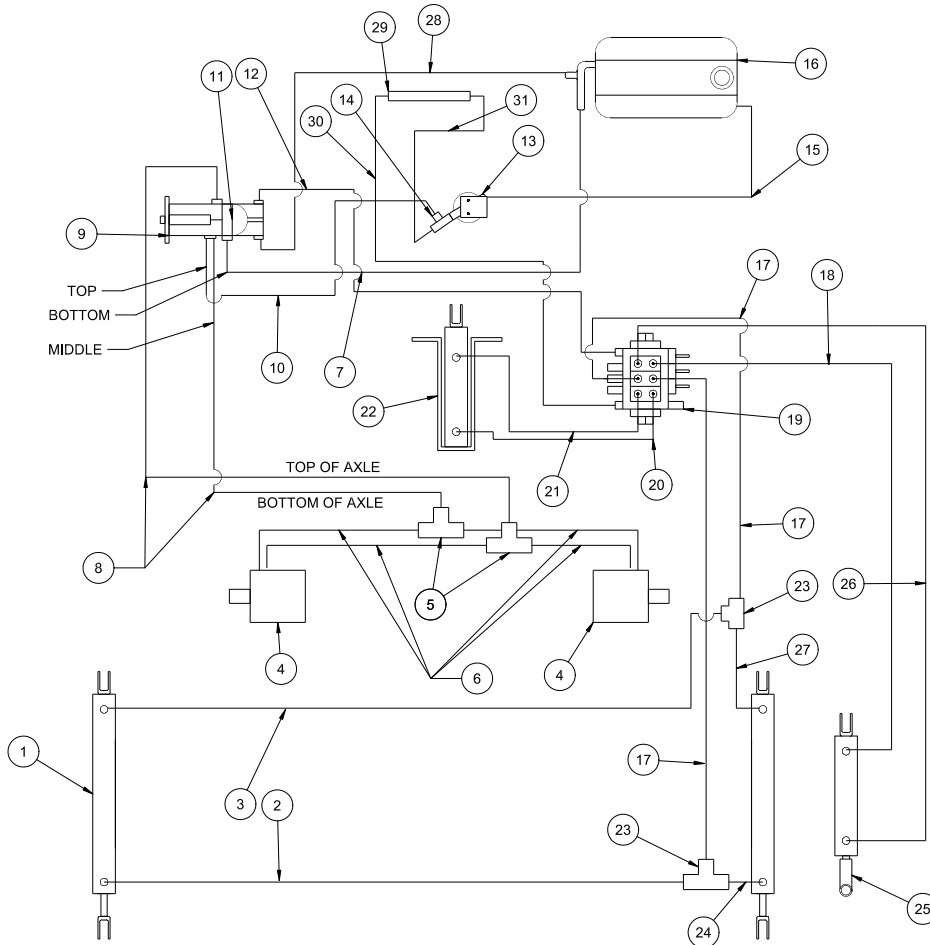

Diagrams

76-023 Hydraulic Valve
Relief Valve set at 2000 psi (137.93 bar)

76-398 Hydrostatic Pump
Displacement Variable to 1.44 in³/R (23.6 cm³/R)
22.44 gpm (84.94 lpm) at 3600 rpm
Max Operating Speed 3600 rpm
Rated Pressure 3000 psi (206.8 bar)
Max Pressure 5000 psi (344.7 bar)
Max Inlet Vacuum 6 in Hg (.203 bar)
Max Inlet Temperature 225°F (107°C)
Max Allowable Case Pressure 25 psi (1.72 bar)

76-197 Gear Pump
Displacement .40 in³/R (6.6 cm³/R) 6.23 gpm (25.39 lpm)

HYDRAULIC DIAGRAM PARTS LIST

REF#	PART#	DESCRIPTION	QUANTITY
1	76-242	Hydraulic Cylinder	2
2	76-115	Hydraulic Hose	1
3	76-114	Hydraulic Hose	1
4	76-238	Wheel Motor	2
5	34-057	Tee	2
6	76-208	Hydraulic Hose	4
7	8832-18.5	Suction Hose (gas)	1
	8832-24	Suction Hose (diesel)	1
	18-040	Hose Clamp	2
8	76-209	Hydraulic Hose	2
	8895-48	1" Hose Wrap	2
9	76-482	Hydrostatic Pump (Gas)	1
	77-239	Hydrostatic Pump (Diesel)	1
10	76-207	Hydraulic Hose	1
	8892-21	1/4" Hose Wrap	1
11	76-197	Gear Pump	1
12	76-104	Hydraulic Hose	1
	8892-29	1/4" Hose Wrap	1
13	23-006	Oil Filter	1
	23-031	Filter Element (Replacement Only)	1
14	18-190	Tee	1
15	8917-38	Suction Hose 5/8 ID	1
	18-040	Hose Clamp	2
16	60-473	Oil Tank	1
17	76-202	Hydraulic Hose	2
18	76-204	Hydraulic Hose	1
	8892-26	1/4" Hose Wrap	1
19	76-023	Hydraulic Valve	1
20	76-205	Hydraulic Hose	1
	8892-31	1/4" Hose Wrap	1
21	76-206	Hydraulic Hose	1
	8892-27	1/4" Hose Wrap	1
22	76-478	Hydraulic Cylinder	1
23	18-173	Tee 3/8 Junction Union	2
24	76-117	Hydraulic Hose	1
25	77-263	Hydraulic Cylinder	1
26	76-203	Hydraulic Hose	1
	8892-26	1/4" Hose Wrap	1
27	76-116	Hydraulic Hose	1
28	8832-17.5	Suction Hose (gas)	1
	8832-17	Suction Hose (diesel)	1
	18-040	Hose Clamp	2
29	23-172	Cooler	1
	76-458	Cooler Mount Kit	1
30	76-459	Hydraulic Hose, 75"	1
	8892-44	Hose Wrap	1
31	76-460	Hydraulic Hose, 63"	1
	8892-44	Hose Wrap	1
32	18-190	Tee	1
	8892	1/4" Hose Wrap	

BODY AND FRAME DRAWING

When Filtration System is to be installed, Ref. 9 Hopper Screen Cover is to be removed.

When Filters are used, 76-262 Tailgate Screen is replaced by 76-249 Tailgate Filter Screen. 76-261 Hopper Screen is replaced by 76-248 Hopper Filter Screen.

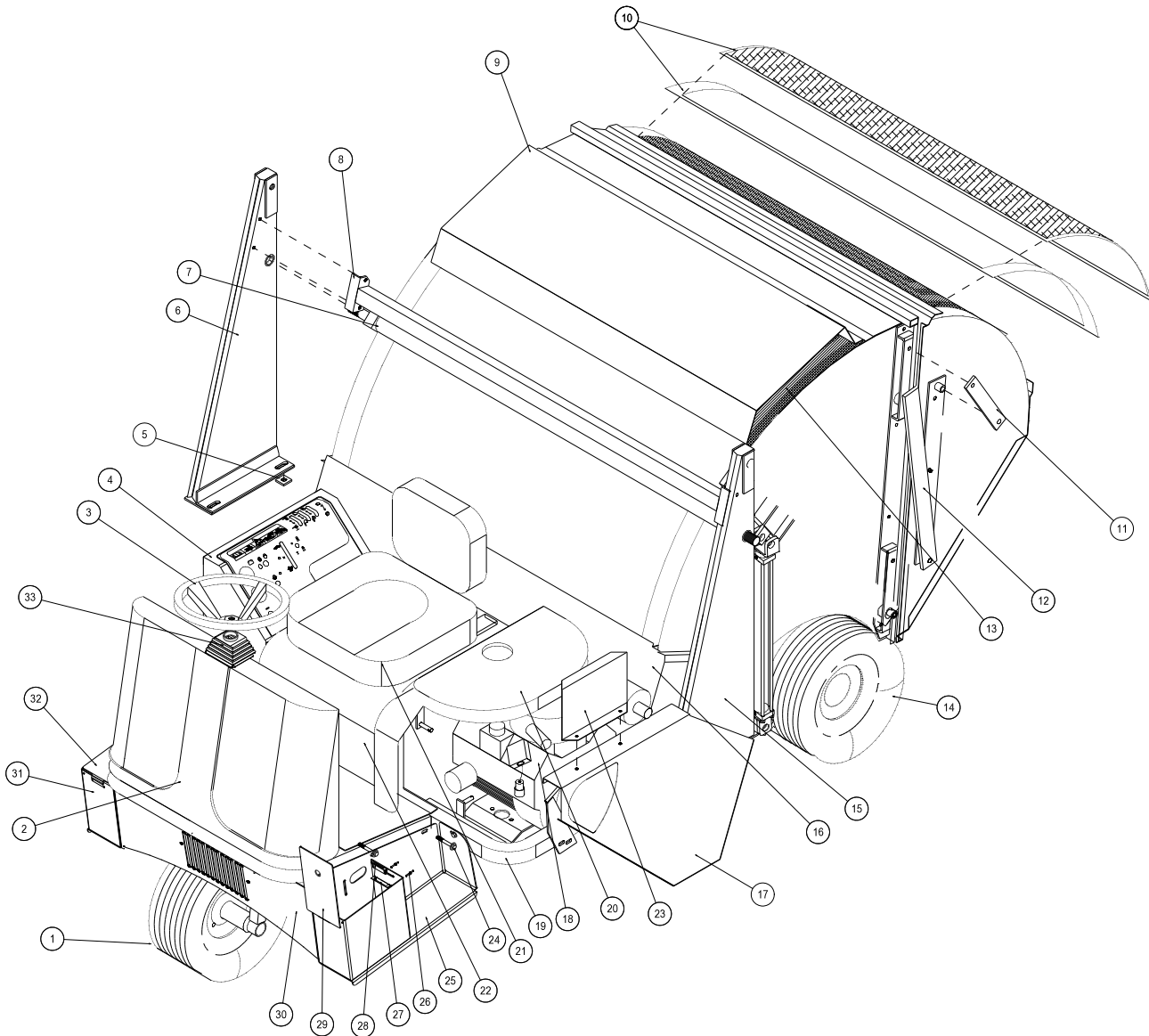

PARTS

BODY AND FRAME PARTS LIST

REF#	PART#	DESCRIPTION	QUANTITY
1§	60-130	Tire and Wheel	1
	60-130-01	Tire, 18 x 9.50 - 8	1
	60-130-02	Wheel	1
	8839	Windshield Washer Fluid or Equivalent	28 pints
2	76-264	Nose Cone	1
	76-354	2½ # ABC Dry Chemical Fire Extinguisher	1
NS	76-372	Inclinometer	1
NS	76-373	Inclinometer Bracket	1
3	13-718	Steering Wheel	1
4	76-265	Gas Console	1
	77-193	Diesel Console	1
	76-219	Console Support	1
5	76-151	Washer	2
6	75-561	Right Tower	1
7	76-211	Arm Pivot Tube	1
8	75-570	Cross Bar	1
9	76-359	Hopper Screen Cover	1
	HB-516-18-075	Hex Bolt, 5/16 -18 x 3/4	6
	HNTL-516-18	Nylon Lock Nut, 5/16 - 18	6
10*	76-249	Tailgate Filter Screen	1
	76-247	Tailgate Filter Pack	1
11	75-564	Tailgate Hinge	2
12	76-413	Right Tailgate Dump Arm	1
13*	76-248	Hopper Filter Screen	1
	76-246	Hopper Filter Pack	1
14	16-225	Tire and Wheel	2
	16-225-01	Tire, 24 x 13 -12NHS	2
	16-225-02	Wheel	2
15	75-629	Left Tower	1
16	76-235	Grass Chute Frame	1
	8947-60	Trim Seal	2
	8842-14	Foam Tape	2
17	76-341	Side Belt Guard	1
	13-388	Spacer	2
18	76-484	Briggs & Stratton 31hp Gas Engine	1
	77-208	D-722 Diesel Kubota Engine	1
19	76-290	Main Frame	1
20	76-435	Gas Engine Cover	1
	77-250	Diesel Engine Cover	1
21	14-294	Seat	1
22	76-289	Seat Assembly	1
23	77-180	Belt Guard (diesel only)	1
24	HB-38-16-300	Hex Bolt, 3/8 -16 x 3	6
	HW-38	Flat Washer, 3/8	6
	HNTL-38-16	Nylon Lock Nut, 3/8 - 16	6
25	48-160	Right Step	1
	8803-10	Black Trim, 10"	1
26	HRS-18-050	Rivet, 1/8 x 1/2	4
	HW-6	Flat Washer, #6	4
27	48-164	Magnet	2
28	48-165	Magnet Bracket	2
29	48-159	Battery Box Cover	2
30	76-457	Front Cover	1
31	48-161	Left Step	1
33	76-362	Tilt Steering	1
§	Front tire and wheel fluid filled to 50 lbs. total.		
*	Optional 76-271	Filtration System (includes Ref. 10 and 13)	1
NS	75-703	Tower Washers	2 Per Side

ROLL-OVER PROTECTION DRAWING

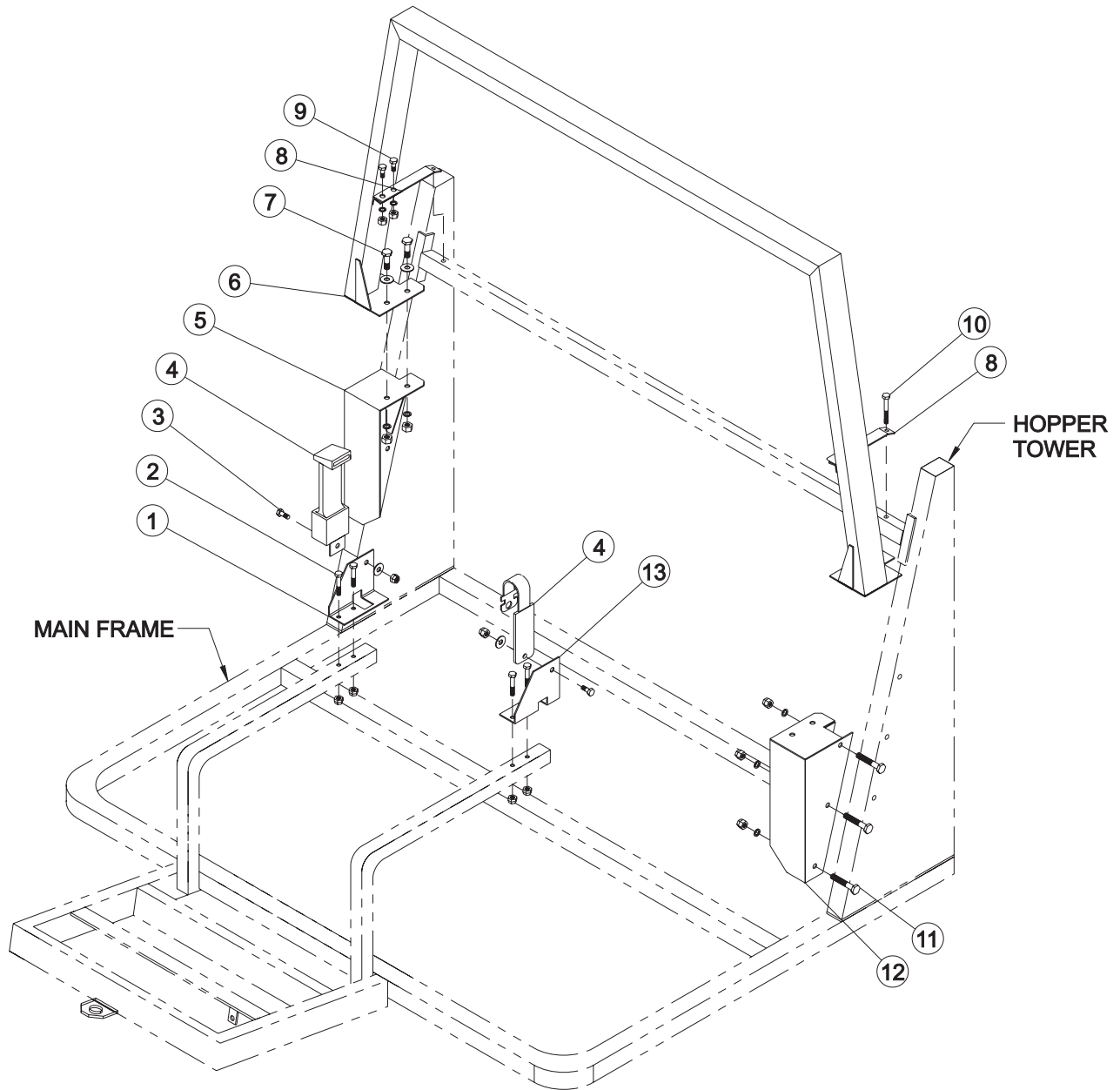

Parts

ROLL-OVER PROTECTION PARTS LIST

REF#	PART#	DESCRIPTION	QUANTITY
1	76-377	Right Seat Belt Bracket	1
2	HB-38-16-200	Hex Bolt, $\frac{3}{8}$ - 16 x 2	4
	HNTL-38-16	Nylon Lock Nut, $\frac{3}{8}$ - 16	4
3	HB-716-14-100	Hex Bolt, $\frac{7}{16}$ - 14 x 1	2
	HNTL-716-14	Nylon Lock Nut, $\frac{7}{16}$ - 14	2
4	76-198-03	Seat Belt	1
5	76-379	Right Support	1
6	76-381	Roll Bar	1
7	HB-12-13-125	Hex Bolt, $\frac{1}{2}$ - 13 x $1\frac{1}{4}$	4
	HW-12	Flat Washer, $\frac{1}{2}$	4
	HWL-12	Lock Washer, $\frac{1}{2}$	4
	HNTL-12-13	Nylon Lock Nut, $\frac{1}{2}$ - 13	4
8	76-376	Strap	2
9	HB-38-16-100	Hex Bolt, $\frac{3}{8}$ - 16 x 1	4
	HWL-38	Lock Washer, $\frac{3}{8}$	4
	HNTL-38-16	Nylon Lock Nut, $\frac{3}{8}$ - 16	4
10	HB-38-16-300	Hex Bolt, $\frac{3}{8}$ - 16 x 3	2
	HWL-38	Lock Washer, $\frac{3}{8}$	2
	HNTL-38-16	Nylon Lock Nut, $\frac{3}{8}$ - 16	2
11	HB-12-13-300	Hex Bolt, $\frac{1}{2}$ - 13 x 3	6
	HNTL-12-13	Nylon Lock Nut, $\frac{1}{2}$ - 13	6
12	76-380	Left Support	1
13	76-378	Left Seat Belt Bracket	1

STEERING DRAWING

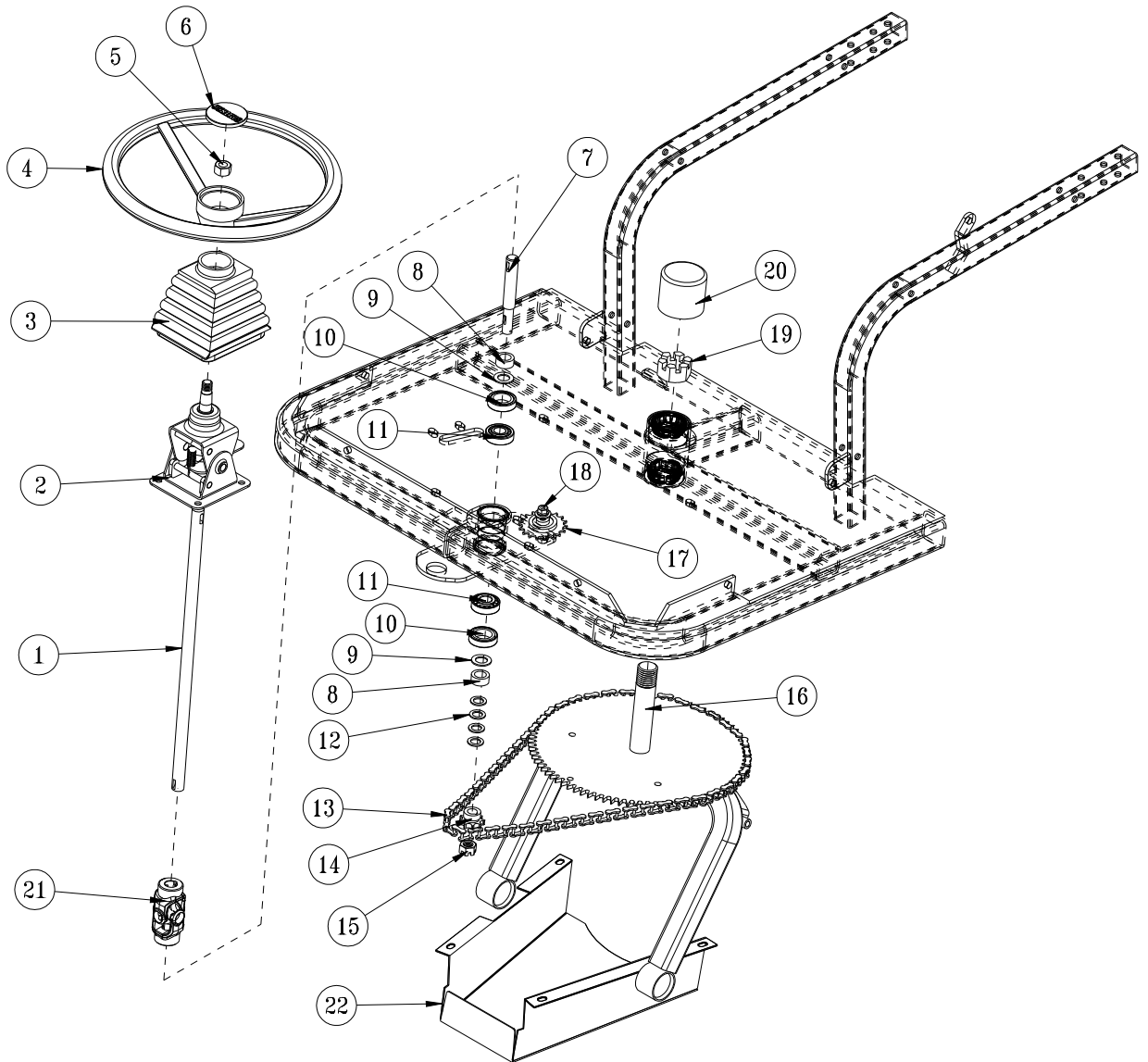

Parts

STEERING PARTS LIST

REF#	PART#	DESCRIPTION	QUANTITY
1	48-186	Steering Shaft	1
	HWK-316-075	Woodruff Key, $\frac{3}{16}$ x $\frac{3}{4}$	1
2	76-362	Tilt Steering Mechanism	1
3	76-364	Tilt Steering Boot	1
4	13-718	Steering Wheel	1
5	HN-58-18	Nut, $\frac{5}{8}$ - 18	1
6	13-726	Steering Wheel Cap	1
7	75-813	Bottom Steering Shaft	1
	HWK-316-075	Woodruff Key, $\frac{3}{16}$ x $\frac{3}{4}$	1
8	11-040	Spacer, $\frac{3}{4}$	2
9	11-039	Seal	2
10	11-038	Bearing Cup and Cone	2
11	11-038-02	Race	2
12	HMB-58-14	Machine Bushing, $\frac{5}{8}$ - 14	as Req'd
13	76-153	Sprocket	1
	HWK-316-063	Woodruff Key, $\frac{3}{16}$ - $\frac{5}{8}$	1
14	8827-59	Roller Chain	1
	18-032	Master Link, #40	1
15	HNA-58-18	Axle Nut, $\frac{5}{8}$ - 18	1
	HP-18-150	Cotter Pin, $\frac{1}{8}$ x $1\frac{1}{2}$	1
16	HB-38-16-175	Hex Bolt, $\frac{3}{8}$ - 16 x $1\frac{3}{4}$	1
	HNTL-38-16	Nylon Lock Nut, $\frac{3}{8}$ - 16	1
17	76-156	Idler Sprocket	1
18	76-155	Front Fork	1
19	HNA-114-12	Axle Nut, $1\frac{1}{4}$ - 12	1
	HP-18-150	Cotter Pin, $\frac{1}{8}$ x $1\frac{1}{2}$	1
20	76-301	Rubber Cap	1
21	75-833	Universal Joint	1
	HSSHS-516-18-038	Socket Head Set Screw, $\frac{5}{16}$ - 18 x $\frac{3}{8}$	4
22	75-803	Chain Guard	1
	HSTP-516-18-100	Phillips Truss Machine Screw, $\frac{5}{16}$ - 18 x 1	4
	HNTL-516-18	Nylon Lock Nut, $\frac{5}{16}$ - 18	4

FRONT FORK DRAWING

Parts

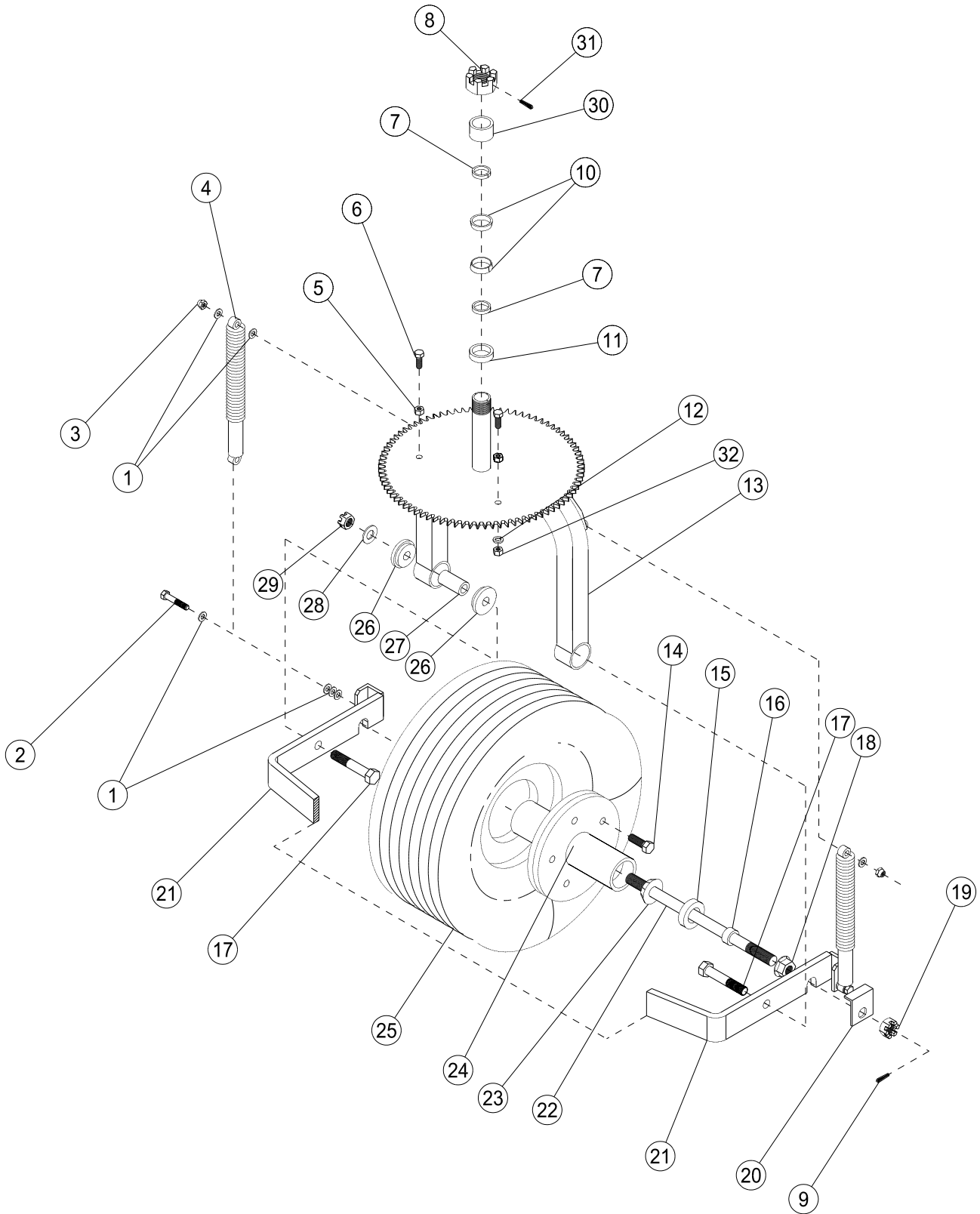

FRONT FORK PARTS LIST

REF#	PART#	DESCRIPTION	QUANTITY
1	HW-38	Flat Washer, $\frac{3}{8}$ (as Req'd)	14
2	HB-38-16-200	Hex Bolt, $\frac{3}{8}$ - 16 x 2	2
	HNTL-38-16	Nylon Lock Nut, $\frac{3}{8}$ - 16	2
3	HB-38-16-250	Hex Bolt, $\frac{3}{8}$ - 16 x 2 $\frac{1}{2}$	2
	HNTL-38-16	Nylon Lock Nut, $\frac{3}{8}$ - 16	2
4	75-715	Shock Absorber	2
	75-866	Bushing Kit	2 per Shock
5	HN-38-16	Hex Nut, $\frac{3}{8}$ - 16	2
6	HB-38-16-100	Hex Bolt, $\frac{3}{8}$ - 16 x 1	2
7	20-142	Grease Seal, $1\frac{1}{4}$	2
8	HNA-114-12	Axle Nut, $1\frac{1}{4}$ - 12	1
10	20-143	Bearing Cup and Cone $1\frac{1}{4}$ ID	2
11	20-141	Spacer	1
12	HWL-38	Lock Washer, $\frac{3}{8}$	2
13	76-155	Front Fork	1
14*	27-022-02	Hex Bolt Stud, $\frac{1}{2}$ - 20 x $1\frac{1}{2}$ (just Hex Bolt; comes with Ref 24)	5
	HNL-12-20	Lug Nut, $\frac{1}{2}$ - 20	5
15*	11-039	Grease Seal, $1\frac{1}{8}$ ID (comes with Ref 24)	2
16	11-040	Spacer	2
17	HB-58-18-350	Hex Bolt, $\frac{5}{8}$ - 18 x $3\frac{1}{2}$	2
18	HNJ-34-16	Jam Nut, $\frac{3}{4}$ - 16	2
19	HNA-34-16	Axle Nut, $\frac{3}{4}$ - 16	2
	HMB-34-10	Machine Bushing, $\frac{3}{4}$ x 10GA	2
	HMB-34-14	Machine Bushing, $\frac{3}{4}$ x 14GA	2
20	60-511	Axle Lock	2
21	60-510	U-Bracket	1
22	60-407	Front Axle	1
23*	11-038	Bearing Cup and Cone $\frac{3}{4}$ ID (comes with Ref 24)	2
24	11-010	Wheel Hub (includes * items)	1
25	60-130	Tire & Wheel	1
	60-130-01	Tire, 18 x 9.5 - 8	1
	60-130-02	Wheel	1
	8839	Windshield Washer Fluid or Equivalent	28 pints
26	60-128	Rubber Bushing	4
27	60-406	Spacer	2
28	HW-58	Flat Washer, $\frac{5}{8}$	2
29	HNTL-58-18	Nylon Lock Nut, $\frac{5}{8}$ - 18	2
	HP-18-100	Cotter Pin, $\frac{1}{8}$ x 1	2
30	76-158	Spacer Seal	1
31	HP-18-200	Cotter Pin, $\frac{1}{8}$ x 2	1
32	HNCL-38-16	Center Nylon Lock Nut, $\frac{3}{8}$ - 16	2

Front tire and wheel fluid filled to 50 lbs. total.

GAS LINKAGE DRAWING

Parts

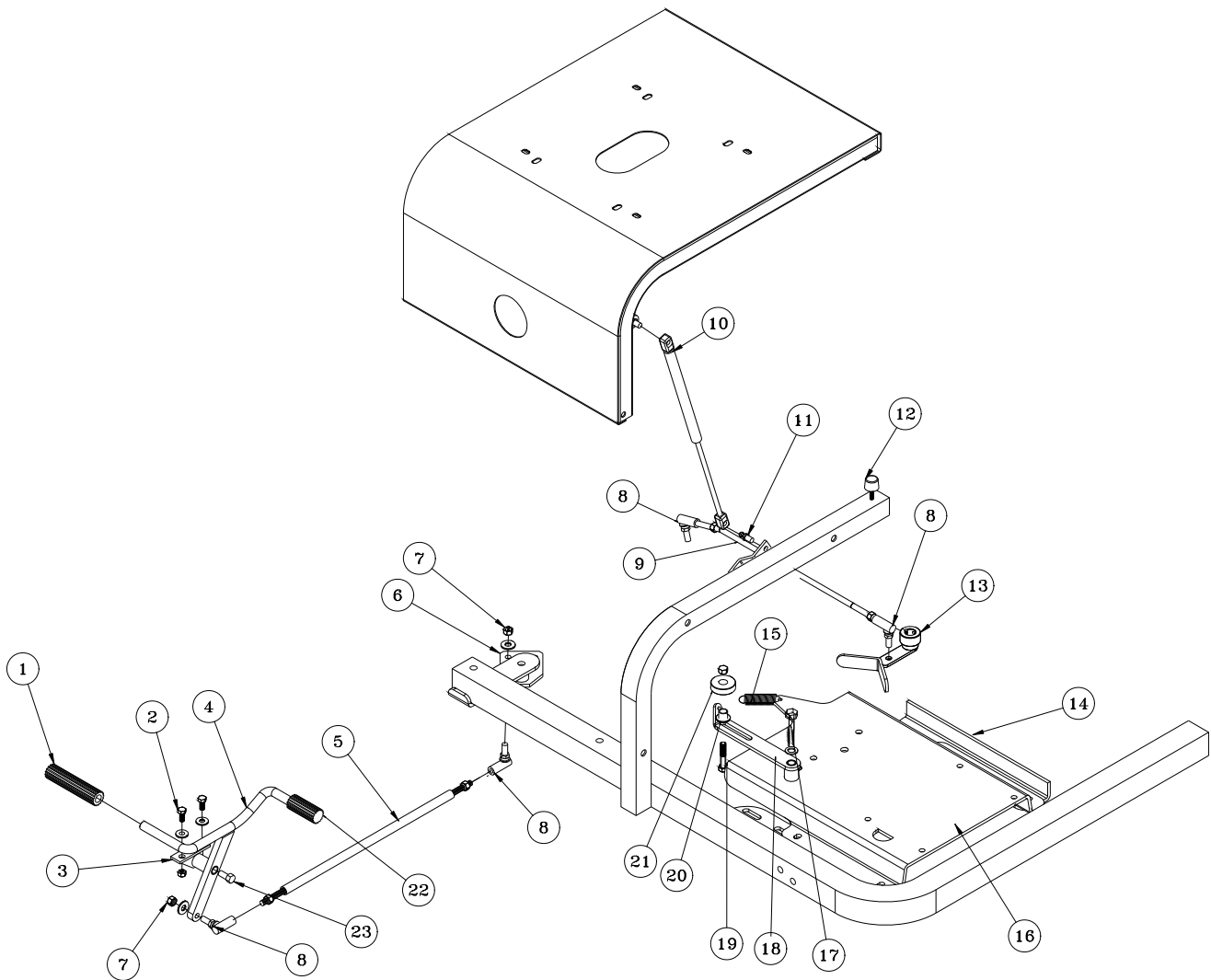

GAS LINKAGE PARTS LIST

REF#	PART#	DESCRIPTION	QUANTITY
1	76-299	Pedal Pad Long	1
2	HB-516-18-075	Hex Bolt, $\frac{5}{16}$ - 18 x $\frac{3}{4}$	2
	HW-516	Flat Washer, $\frac{5}{16}$	2
	HNTL-516-18	Nylon Lock Nut, $\frac{5}{16}$ - 18	2
3	76-296	Pedal Mount	1
	18-234	Oilite Bushing	2
	HG-14-28-180	Grease Fitting, $\frac{1}{4}$ - 28 x 180°	1
4	48-059	Foot Pedal	1
	18-234	Oilite Bushing	1
5	76-282	Foot Pedal Rod	1
	HN-38-24	Hex Nut, $\frac{3}{8}$ - 24	2
6	75-791	Shift Relay	1
	10-007	Bushing	1
7	HN-38-24	Hex Nut, $\frac{3}{8}$ - 24	4
	HWL-38	Lock Washer, $\frac{3}{8}$	4
8	21-173	Ball Joint, $\frac{3}{8}$ - 24	4
9	76-403	Rear Linkage Rod	1
	HN-38-24	Hex Nut, $\frac{3}{8}$ - 24	2
10	13-569	Gas Spring, 60#	1
11	26-034	Ball Stud	2
12	15-013	Rubber Bumper	2
	HWL-14	Lock Washer, $\frac{1}{8}$	2
	HN-14-20	Hex Nut, $\frac{1}{4}$ - 20	2
13	76-401	Shift Arm	1
	HSSHS-14-28-031	Set Screw, $\frac{1}{4}$ - 28 x $\frac{5}{16}$ (comes with 76-401)	1
14		Mainframe	1
15	48-109	Spring	1
	9019-5.5	$\frac{3}{4}$ " Heat Shrink Tubing x 5.5"	1
16	76-404	Motor Mount	1
17	HB-12-13-275	Hex Bolt, $\frac{1}{2}$ - 13 x $2\frac{3}{4}$	1
	HN-12-13	Hex Nut, $\frac{1}{2}$ - 13	2
	HWL-12	Lock Washer, $\frac{1}{2}$	1
	HMB-12-14	Machine Bushing, $\frac{1}{2}$ x 14GA	2
18	76-402	Idler Arm	1
	18-234	Bushing (part of 76-402)	1
	HG-14-28-180	Grease Fitting, $\frac{1}{4}$ - 28 x 180°	1
19	HB-38-16-200	Hex Bolt, $\frac{3}{8}$ - 16 x 2	1
	HW-38	Flat Washer, $\frac{3}{8}$	2
	HNTL-38-16	Nylon Lock Nut, $\frac{3}{8}$ - 16	1
20	18-270	Oilite Bushing	1
21	14-266	Ball Bearing, $\frac{5}{8}$ ID x $1\frac{3}{4}$ OD	1
22	76-332	Pedal Pad Short	1
23	HB-12-13-250	Hex Bolt, $\frac{1}{2}$ - 13 x $2\frac{1}{2}$	1
	HNTL-12-13	Nylon Lock Nut, $\frac{1}{2}$ - 13	1

DIESEL LINKAGE DRAWING

PARTS

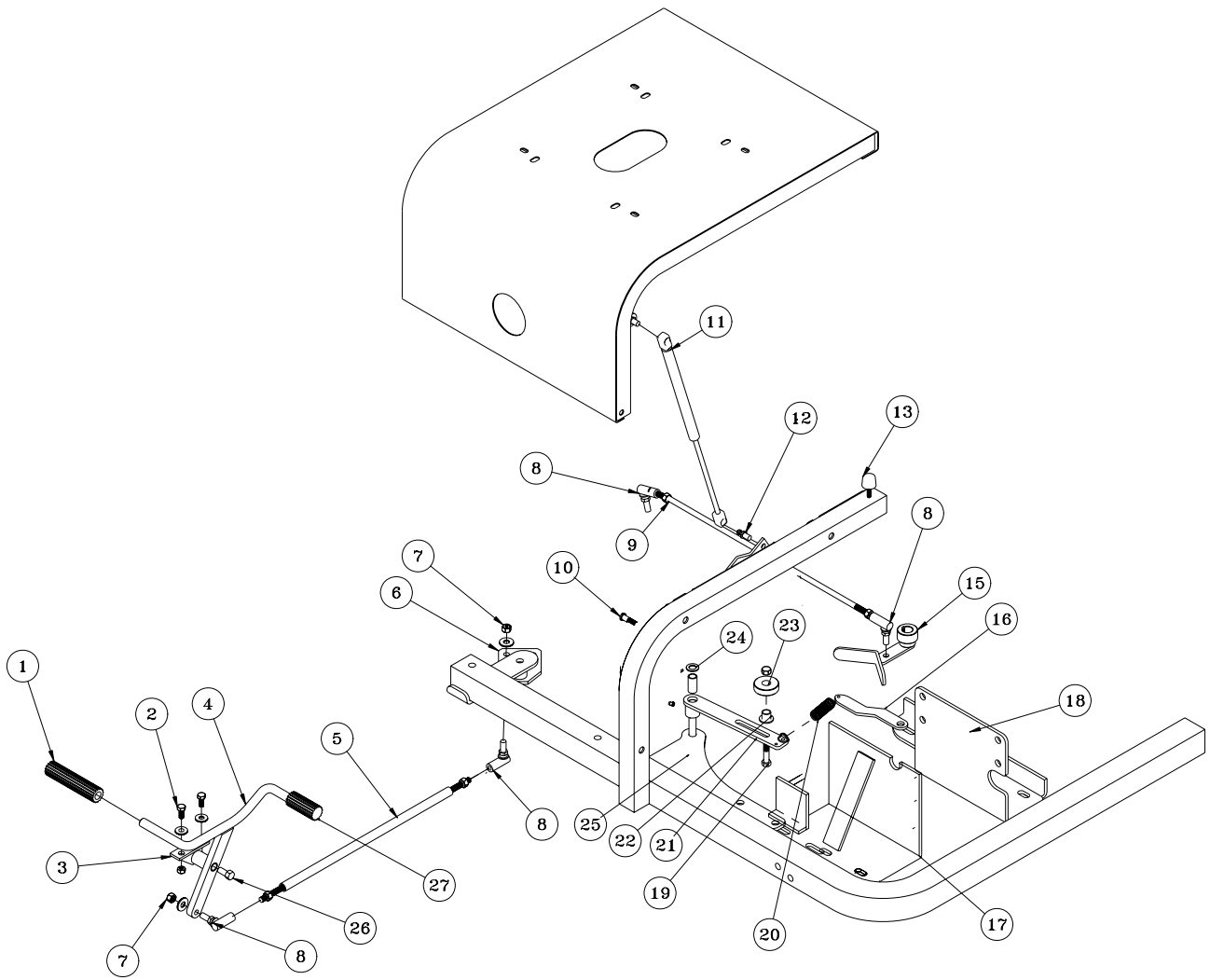

DIESEL LINKAGE PARTS LIST

REF#	PART#	DESCRIPTION	QUANTITY
1	76-299	Pedal Pad Long	1
2	HB-516-18-075	Hex Bolt, $\frac{5}{16}$ - 18 x $\frac{3}{4}$	2
	HW-516	Flat Washer, $\frac{5}{16}$	2
	HNTL-516-18	Nylon Lock Nut, $\frac{5}{16}$ - 18	2
3	76-296	Pedal Mount	1
	18-234	Oilite Bushing	2
	HG-14-28-180	Grease Fitting, $\frac{1}{4}$ - 28 x 180°	1
4	48-059	Foot Pedal	1
	18-234	Oilite Bushing	1
5	76-282	Foot Pedal Rod	1
	HN-38-24	Hex Nut, $\frac{3}{8}$ - 24	2
6	75-791	Shift Relay	1
	10-007	Bushing	1
7	HN-38-24	Hex Nut, $\frac{3}{8}$ - 24	4
	HWL-38	Lock Washer, $\frac{3}{8}$	4
8	21-173	Ball Joint, $\frac{3}{8}$ - 24	4
9	77-197	Rear Linkage Rod	1
	HN-38-24	Hex Nut, $\frac{3}{8}$ - 24	2
10	HSDPS-14-075	Stainless Steel Pan Head Drill Screw, $\frac{1}{4}$ x $\frac{3}{4}$	1
11	13-569	Gas Spring, 60#	1
12	26-034	Ball Stud	2
13	15-013	Rubber Bumper	2
	HWL-14	Lock Washer, $\frac{1}{4}$	2
	HN-14-20	Hex Nut, $\frac{1}{4}$ - 20	2
15	77-241	Shift Arm	1
	HSSHS-14-28-031	Socket Set Screw, $\frac{1}{4}$ - 28 x $\frac{5}{16}$ (comes with 77-241)	1
16	77-265	Spring Bracket	1
17	77-185	Front Engine Mount	1
18	77-186	Rear Engine Mount	1
19	HB-38-16-200	Hex Bolt, $\frac{3}{8}$ - 16 x 2	1
	HW-38	Flat Washer, $\frac{3}{8}$	2
	HNTL-38-16	Nylon Lock Nut, $\frac{3}{8}$ - 16	1
	22-065	Auxiliary Ground (to back of engine)	1
20	21-445	Spring	1
21	76-370	Idler Arm	1
22	76-275	Spacer	1
23	14-266	Ball Bearing	1
24	HP-18-075	Cotter Pin, $\frac{1}{8}$ x $\frac{3}{4}$	1
	HMB-12-14	Machine Bushing, $\frac{1}{2}$ x 14GA	2
25	76-371	Linkage Plate	1
	HG-14-28-180	Grease Fitting, $\frac{1}{4}$ - 28 x 180°	1
26	HB-12-13-250	Hex Bolt, $\frac{1}{2}$ - 13 x 2 $\frac{1}{2}$	1
	HNTL-12-13	Nylon Lock Nut, $\frac{1}{2}$ - 13	1
27	76-332	Pedal Pad Short	1

GAS CONSOLE DRAWING

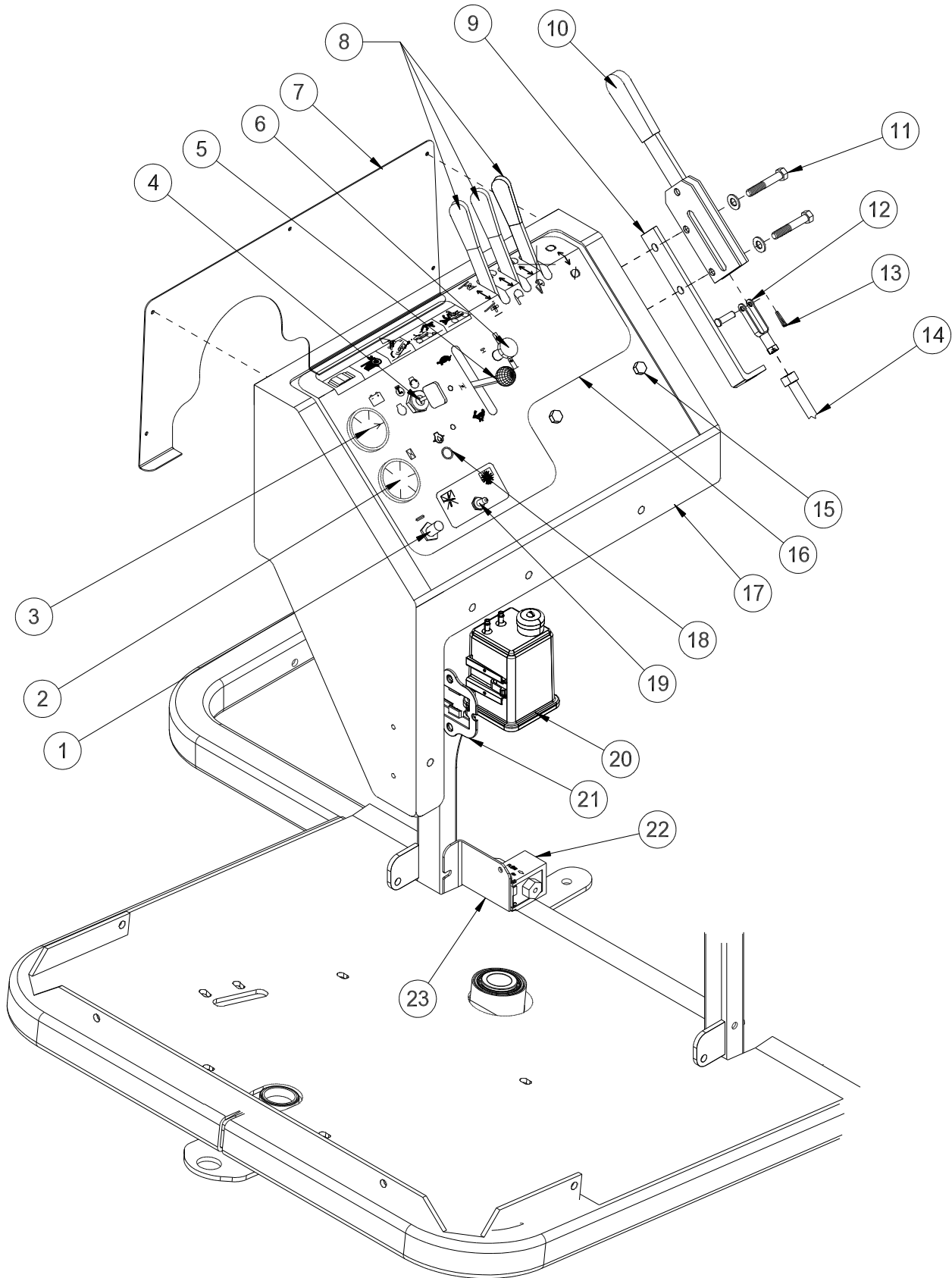

Parts

GAS CONSOLE PARTS LIST

REF#	PART#	DESCRIPTION	QUANTITY
1	77-261	Circuit Breaker	1
	8977	Circuit Breaker Boot	1
2	12-804	Hour Meter	1
3	76-397	Voltmeter	1
4	13-488	Key Switch	1
	76-310	Key Set	1
5	76-528	Throttle Cable	1
	HSM-10-32-063	Machine Screw, 10 - 32 x 5/8	6
	HWL-10	Lock Washer, 10	6
	HN-10-32	Hex Nut, 10 - 32	6
6	80-020	Choke Cable	1
7	76-479	Side Panel	1
	HSA-8-075	Tapping Screw, #8 x 3/4	4
8	76-309	Valve Handle (with Linkage Kit)	1
	76-023	Hydraulic Valve (3 bank)	1
9	76-224	Park Brake Handle Mount	1
10	60-106	Brake Lever	1
11	HB-516-18-250	Hex Bolt, 5/16 - 18 x 2 1/2	2
	HW-516	Flat Washer, 5/16	6
	HNTL-516-18	Nylon Lock Nut, 5/16 - 18	2
12	11-100	Linkage Yoke, 5/16 (one each end of brake cable)	2
	HN-516-24	Hex Nut, 5/16 - 24	2
13	HP-18-100	Cotter Pin, 1/8 x 1	1
	HCP- 516-100	Clevis Pin, 5/16 x 1	1
14	76-225	Brake Cable (with nuts)	1
	60-536	Bellows (one each end of brake cable)	2
15	HB-38-16-100	Hex Bolt, 3/8 - 16 x 1 (holds 76-023 Valve)	2
	HW-38	Flat Washer, 3/8	2
	HW-516	Flat Washer, 5/16	2
	HNTL-38-16	Nylon Lock Nut, 3/8 - 16	2
16	76-199	Decal, Control Panel	1
17	76-265	Console	1
18	50-359	Warning Indicator Light	1
19	15-314	Electric Clutch Switch	1
	15-472	Switch Boot	1
20	8-689	Carbon Canister	1
21	8-688	Carbon Canister Mount	1
	HSTP-14-20-075	Truss Head Screw, 1/4 -20 x 3/4	2
	HNFL-14-20	Flange Whiz-loc Nut, 1/4 - 20	2
22	76-471	Fuel Pump	1
23	76-470	Pump Bracket	1



DIESEL CONSOLE DRAWING

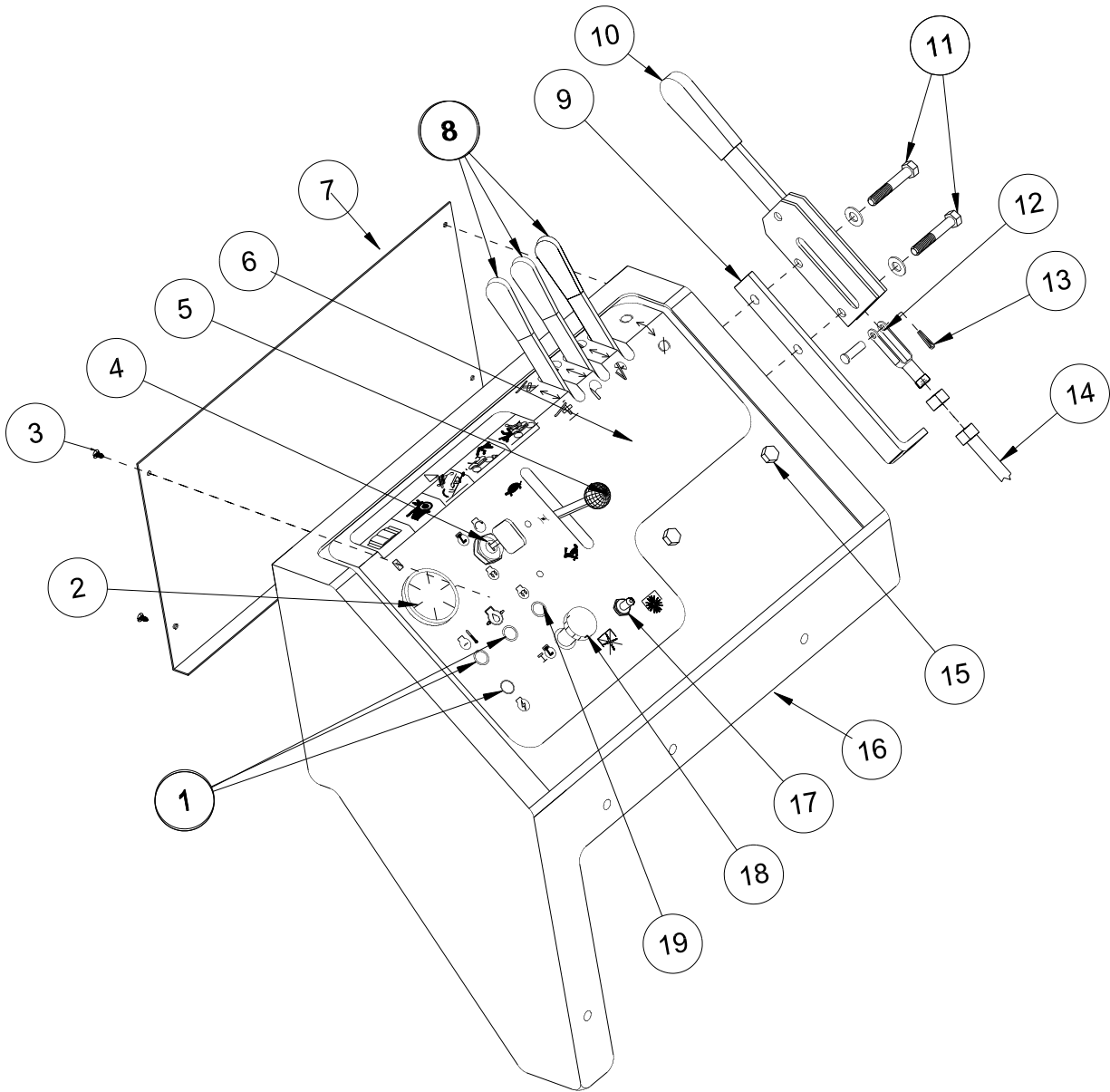

PARTS

DIESEL CONSOLE PARTS LIST

REF#	PART#	DESCRIPTION	QUANTITY
1	50-359	Warning Indicator Light	3
2	12-804	Hour Meter	1
3	HSA-8-075	Tapping Screw, #8 x 3/4	4
4	17-068	Key Switch	1
	17-079	Key Set	1
5	34-160	Throttle, 48"	1
	34-159	Throttle Mounting Bracket	1
	HSM-10-32-063	Machine Screw, 10 - 32 x 5/8	6
	HWL-10	Lock Washer, 10	6
	HN-10-32	Hex Nut, 10 - 32	6
6	77-178	Decal, Control Panel	1
7	76-214	Side Panel	1
8	76-309	Valve Handle (with Linkage Kit)	1
	76-023	Hydraulic Valve (3 bank)	1
9	76-224	Park Brake Handle Mount	1
10	60-106	Brake Lever	1
11	HB-516-18-250	Hex Bolt, 5/16 - 18 x 2 1/2	2
	HW-516	Flat Washer, 5/16	6
	HNTL-516-18	Nylon Lock Nut, 5/16 - 18	2
12	11-100	Linkage Yoke, 5/16	1
	HN-516-24	Hex Nut, 5/16 - 24	2
13	HP-18-100	Cotter Pin, 1/8 x 1	1
	HCP- 516-125	Clevis Pin, 5/16 x 1 1/4	1
14	76-225	Brake Cable (with nuts)	1
	60-536	Bellows (one each end of brake cable)	2
15	HB-38-16-100	Hex Bolt, 3/8 - 16 x 1 (holds 76-023 Valve)	2
	HW-38	Flat Washer, 3/8	2
	HNTL-38-16	Nylon Lock Nut, 3/8 - 16	2
16	77-193	Console	1
17	15-314	Electric Clutch Toggle Switch	1
	15-472	Boot	1
18	77-206	Kill Control	1
	18-275	Ball Joint	1
19	50-359	Glow Plug Indicator Light	1

GAS TANK AND OIL TANK DRAWING

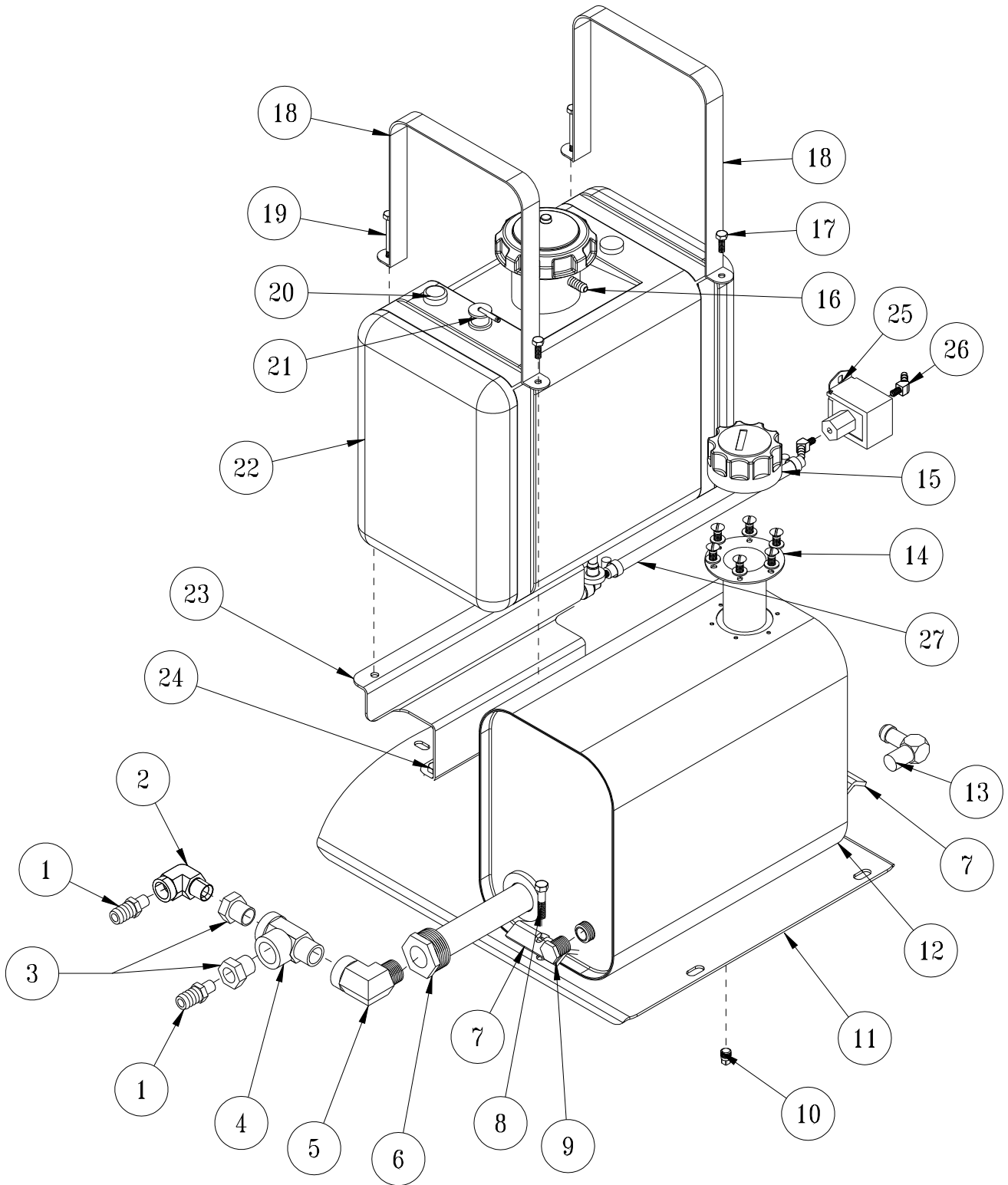

Accessories

GAS TANK AND OIL TANK PARTS LIST

REF#	PART#	DESCRIPTION	QUANTITY
1	18-133	Barb Fitting	2
2	18-009	Street Elbow	1
3	18-008	Pipe Reducer, $\frac{3}{4}$ x $\frac{1}{2}$	2
4	18-093	Male Run Tee, $\frac{3}{4}$	1
5	18-140	Street Elbow, $\frac{3}{4}$	1
6	60-213	Strainer	1
7	75-792	Mounts	2
8	HB-516-18-150	Hex Bolt, $\frac{5}{16}$ - 18 x $1\frac{1}{2}$	2
	HW-516	Flat Washer, $\frac{5}{16}$	1
	HNTL-516-18	Nylon Lock Nut, $\frac{5}{16}$ - 18	2
9	18-069	Pipe Plug, $\frac{1}{2}$	1
10	18-118	Pipe Plug, $\frac{1}{8}$	1
11	76-477	Tank Mount	1
12	60-473	Oil Tank	1
13	23-142	Connector	1
	18-040	Hose Clamp	1
	8917-38	Suction Hose, $\frac{5}{8}$ ID	1
14	13-586-03	Filler Neck	1
	13-586-02	Bottom Gasket	1
	HSM-10-32-063	Machine Screw	6
	HWL-10	Lock Washer, M10	6
15	13-747	Filler Breather	1
	13-586-01	Cap Gasket	1
16	*	Neck Vent Port	1
	8800-24	Fuel Hose (tank to carb canister)	1
	18-186	Hose Clamp	2
17	HB--14-20-075	Hex Bolt, $\frac{1}{4}$ - 20 x $\frac{3}{4}$	2
	HNTL-14-20	Nylon Lock Nut, $\frac{1}{4}$ - 20	2
18	76-476	Tank Straps	2
19	HB-14-20-250	Hex Bolt, $\frac{1}{4}$ - 20 x $2\frac{1}{2}$	2
	HNTL-14-20	Nylon Lock Nut, $\frac{1}{4}$ - 20	2
20	15-838-01	Dial Fuel Level Gauge	1
21	*	Top Draw	1
	8800-77	Fuel Hose (tank to engine)	1
	18-186	Hose Clamp	2
22	15-838	CARB Gas Tank (includes all * items)	1
	73-050	Vented Cap With Gauge	1
	50-403	Inline Fuel Filter	1
23	76-475	Tank Brackets	2
24	HB-516-18-100	Hex Bolt, $\frac{5}{16}$ - 18 x 1	4
	HNTL-516-18	Nylon Lock Nut, $\frac{5}{16}$ - 18	4
25	76-471	Fuel Pump	1
26	18-420	Hose Barb	2
27	8800-22.5	$\frac{1}{4}$ " Fuel Hose x 22.5"	1
	18-186	Hose Clamp	2

DIESEL FUEL TANK AND OIL TANK DRAWING

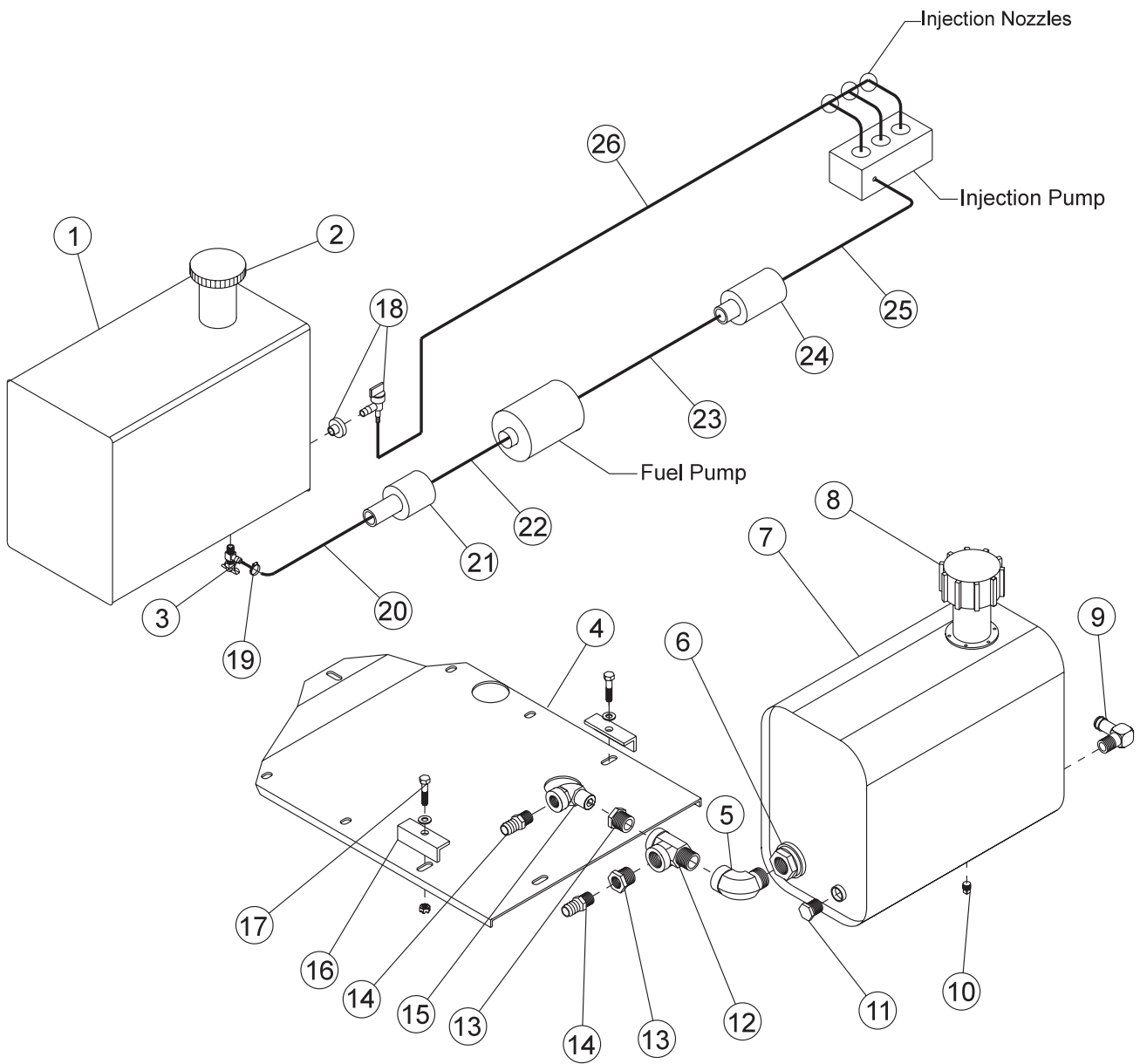

Parts

DIESEL FUEL TANK AND OIL TANK PARTS LIST

REF#	PART#	DESCRIPTION	QUANTITY
1	15-491	Fuel Tank	1
	HB 14-20-075	Hex Bolt, $\frac{1}{4}$ - 20 x $\frac{3}{4}$	4
	HWL-14	Lock Washer, $\frac{1}{4}$	4
	HW-14	Flat Washer, $\frac{1}{4}$	4
2	15-492	Gas Cap with Gauge	1
	77-179	Diesel Fuel Cap with Gauge	1
3	15-039	Fuel Valve	1
	18-042	Reducer Bushing, $\frac{1}{4}$ x $\frac{1}{8}$	1
4	76-221	Tank Mount	1
5	18-140	Street Elbow	1
6	60-213	Strainer	1
7	60-473	Oil Tank (includes * items)	1
8	13-747	Filler Breather	1
	13-586-03	Neck	1
	HSM-10-32-063	Machine Screw	6
	HWL-10	Lock Washer, M10	6
9	23-142	Connector	1
	18-040	Hose Clamp	1
	8917-38	Suction Hose, $\frac{5}{8}$ ID	1
10*	18-118	Pipe Plug, $\frac{1}{8}$	1
11*	18-069	Pipe Plug, $\frac{1}{2}$	1
12	18-093	$\frac{3}{4}$ " Male Run Tee	1
13	18-008	Pipe Reducer, $\frac{3}{4}$ x $\frac{1}{2}$	2
14	18-133	Barb Fitting	2
15	18-009	Street Elbow, $\frac{1}{2}$	1
16	75-792	Mounts	2
17	HB-516-18-150	Hex Bolt, $\frac{5}{16}$ - 18 x $1\frac{1}{2}$	2
	HW-516	Flat Washer, $\frac{5}{16}$	1
	HNTL-516-18	Nylon Lock Nut, $\frac{5}{16}$ - 18	2
18	26-054	Bushing Insert (part of tank)	1
	26-055	Shut-Off Valve (part of tank)	1
19	18-186	Hose Clamp, $\frac{7}{32}$ - $\frac{5}{8}$	10
20	8800-14	Fuel Hose, $\frac{1}{4}$ " x 14"	1
21	50-403	In-Line Fuel Filter	1
22	8800-49	Fuel Hose, $\frac{1}{4}$ " x 49"	1
23	8800-16	Fuel Hose, $\frac{1}{4}$ " x 16"	1
24	77-214	Fuel Filter Assembly (part of engine)	1
	17-043	Fuel Filter Element (part of engine)	1
25	8800-11	Fuel Hose, $\frac{1}{4}$ " x 11"	1
26	8800-51	Fuel Hose, $\frac{1}{4}$ " x 51"	1

OIL FILTER DRAWING

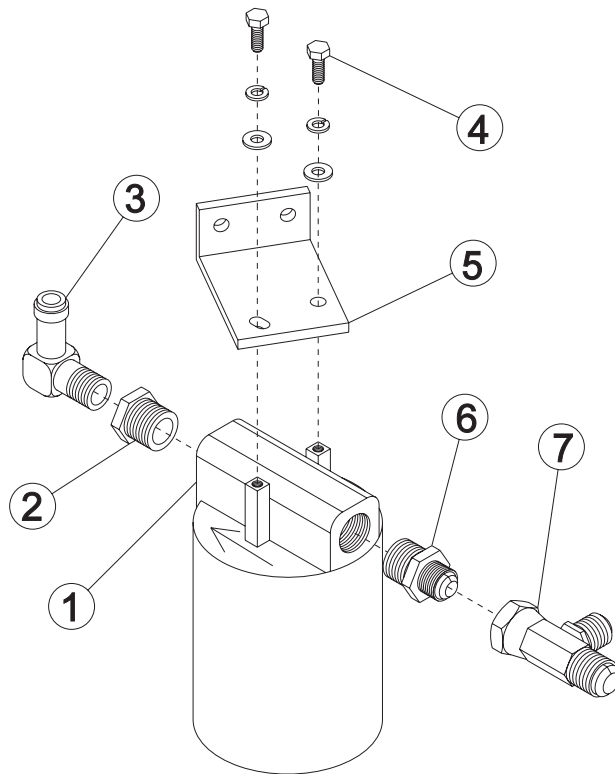

HYDRAULIC LIFT CYLINDER DRAWING

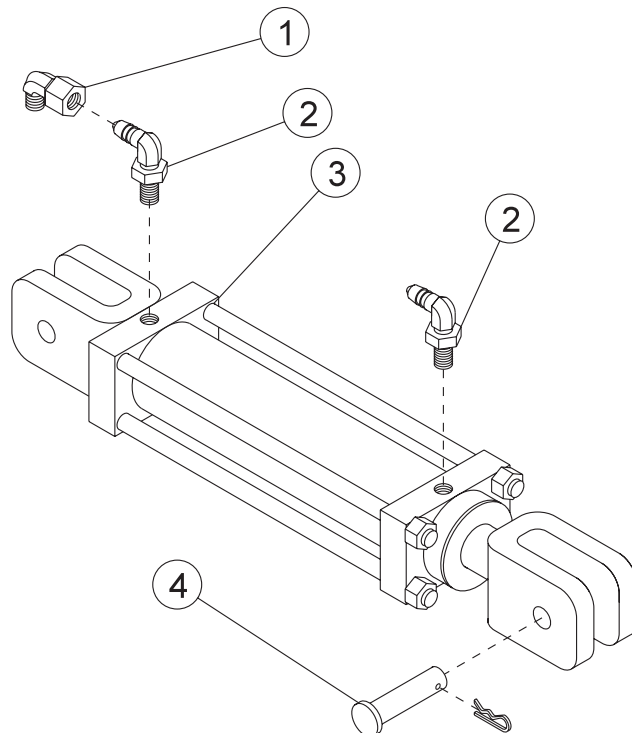

OIL FILTER PARTS LIST

REF#	PART#	DESCRIPTION	QUANTITY
1	23-006	Oil Filter	1
	23-031	Filter Element (replacement only)	1
2	18-008	Pipe Reducer, $\frac{3}{4}$ x $\frac{1}{2}$	1
3	23-142	Connector	1
4	HB-14-20-075	Hex Bolt, $\frac{1}{4}$ - 20 x $\frac{3}{4}$	2
	HWL-14	Lock Washer, $\frac{1}{4}$	2
	HW-14	Flat Washer, $\frac{1}{4}$	2
5	75-806	Filter Bracket	1
6	23-183	Male Connector	1
7	18-190	Tee	1

HYDRAULIC LIFT CYLINDER PARTS LIST

REF#	PART#	DESCRIPTION	QUANTITY
1	18-202	Elbow	1
2	23-167	Elbow	2
3	76-242	Hydraulic Cylinder	1
	76-242-01	Seal Kit	1
4	HCP-100-325	Clevis Pin, 1 x $\frac{3}{4}$	1
	HHP-.177	Bridge Pin	1

Torque Specification

Piston Nut	165 ft/lbs (214.5 Nm)
Tie Rod Nut	30 ft/lbs (39 Nm)
Clevis Nut	46 ft/lbs (59.8 Nm)

REEL LIFT CYLINDER DRAWING

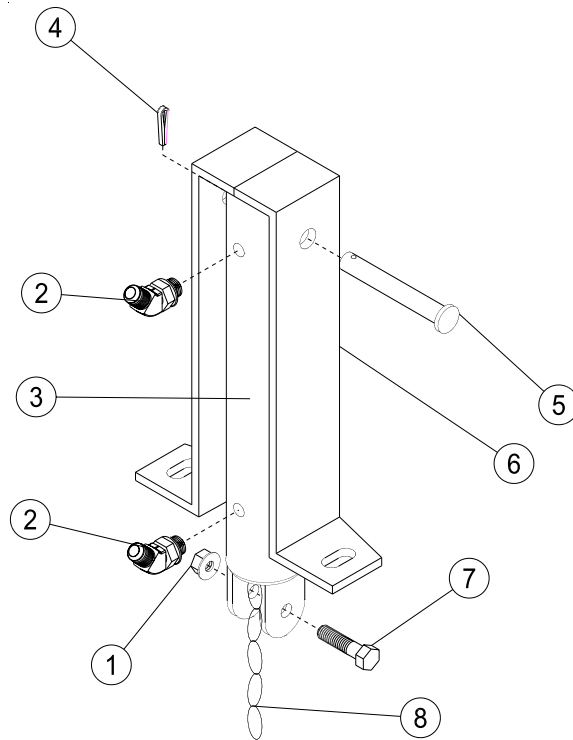

TAILGATE CYLINDER DRAWING

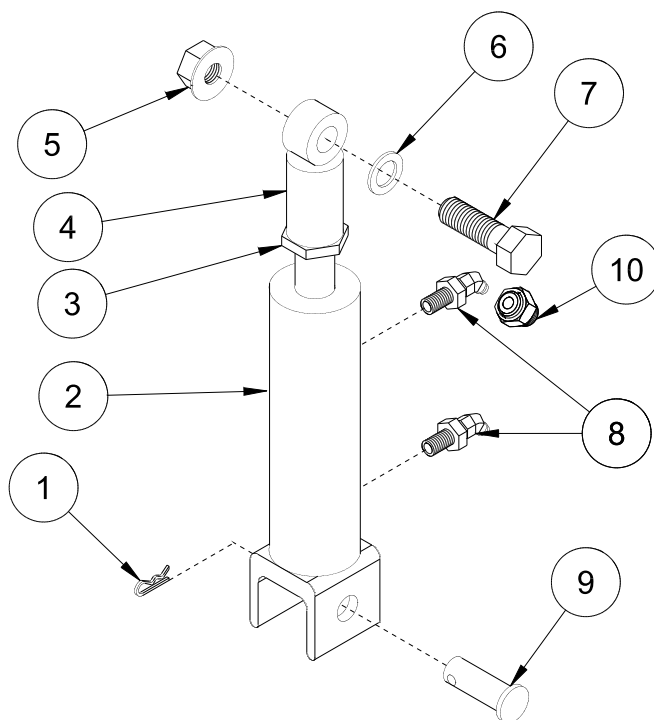

REEL LIFT CYLINDER PARTS LIST

REF#	PART#	DESCRIPTION	QUANTITY
1	HNTL-38-16	Nylon Lock Nut, $\frac{3}{8}$ - 16	2
2	18-188	Elbow, $\frac{3}{8}$ SAE	2
3	76-478 14-531	Hydraulic Cylinder, 2 x 7 x $\frac{3}{4}$ Seal Kit	1
4	HP-18-100	Cotter Pin, $\frac{1}{8}$ x 1	1
5	HCP-12-350	Clevis Pin, $\frac{1}{2}$ - 3 $\frac{1}{2}$	1
6	75-827	Cylinder Bracket	1
7	HB-38-16-150	Hex Bolt, $\frac{3}{8}$ - 16 x 1 $\frac{1}{2}$	1
8	8820-8	Machine Chain St. Link	1

TAILGATE CYLINDER PARTS LIST

REF#	PART#	DESCRIPTION	QUANTITY
1	HHP-18	Bridge Pin, $\frac{1}{8}$	1
2	77-263 14-530	Hydraulic Cylinder, 1 $\frac{1}{2}$ x 7 Seal Kit	1
3	HNJ-58-18	Jam Nut, $\frac{5}{8}$ - 18	1
4	18-154 HG-14-28-180	Rod End Grease Fitting, $\frac{1}{4}$ - 28 x 180°	1
5	HNTL-58-11	Nylon Lock Nut, $\frac{5}{8}$ - 11GA	1
6	HMB-58-14	Machine Bushing, $\frac{5}{8}$ - 14GA	1
7	HB-58-11-200	Hex Bolt, $\frac{5}{8}$ - 11 x 2	1
8	18-168	Elbow	2
9	HCP-58-150	Clevis Pin, $\frac{5}{8}$ x 1 $\frac{1}{2}$	1
10	18-392	Orifice Fitting	1

GAS ENGINE AND EXHAUST DRAWING

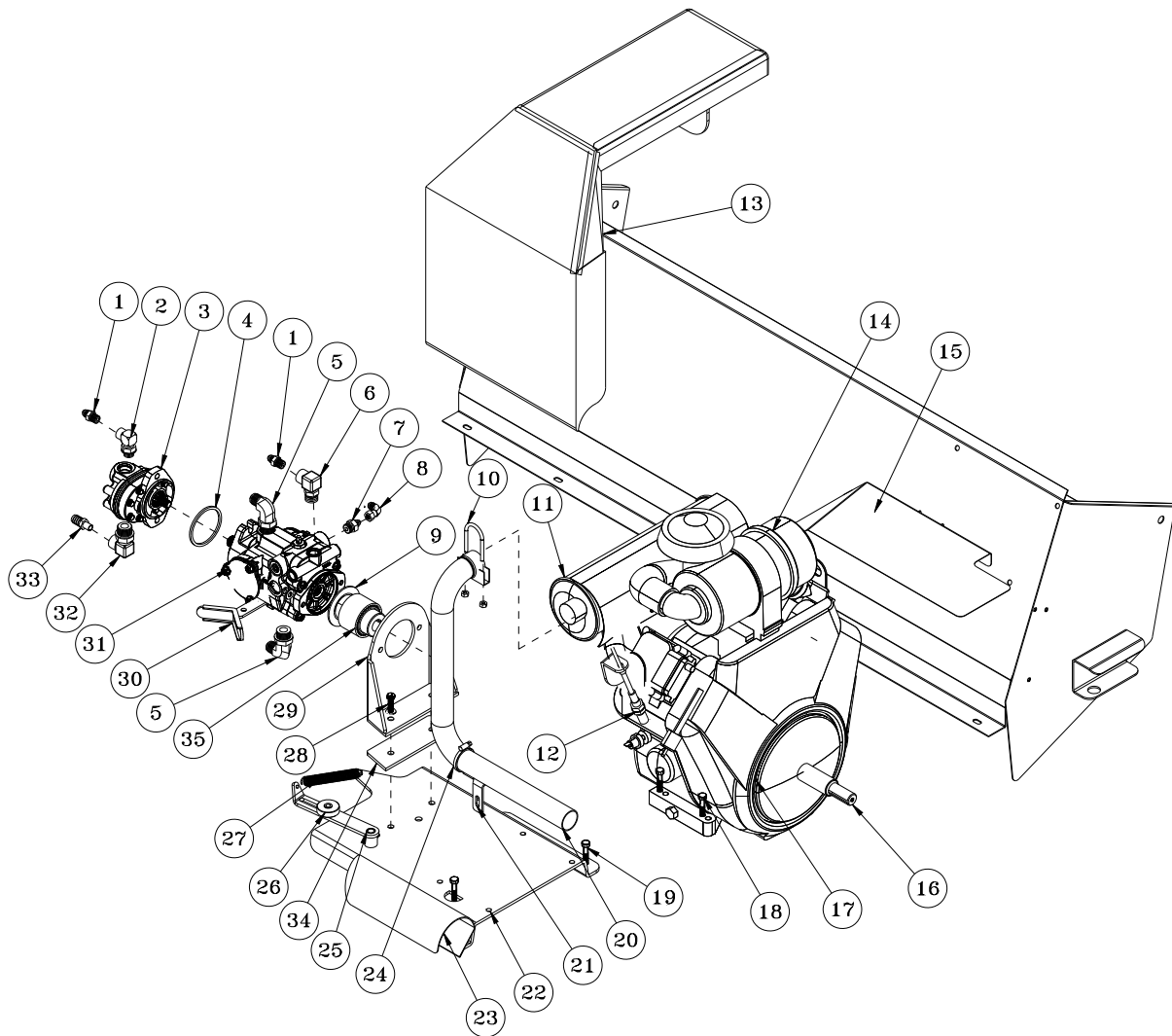

PARTS

Cyclonic air cleaner
76-395-04

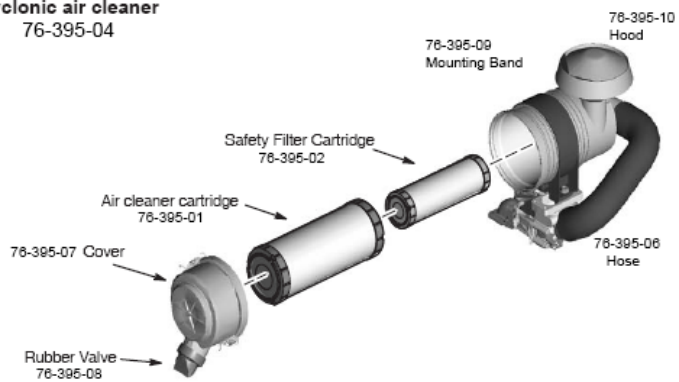

GAS ENGINE AND EXHAUST PARTS LIST

REF#	PART#	DESCRIPTION	QUANTITY
1	18-133	Barb Fitting	2
2	23-133	Adjustable Elbow, 90°	1
3	76-197	Gear Pump	1
4	23-145	O-Ring, 3¼ ID x 3⅜ OD	1
5	18-204	Elbow, 90°	2
6	23-130	Elbow, 90°	1
7	18-241	Straight Thread Connector	1
8	18-202	Elbow	1
9	76-465	Pump Coupling Complete	1
10	50-394	Muffler Clamp	1
11	76-448	Muffler	1
12	76-528	Throttle Cable	1
13	76-435	Engine Cover (Fiberglass)	1
	9013-32	Heat Reflective Fabric (16 x 32)	1
14	76-395-04	Cyclonic Air Cleaner	1
	76-395-01	Air Cleaner Cartridge	1
	76-395-02	Safety Filter Cartridge	1
15	76-405	Debris Shield	1
16	76-411	Stub Shaft	1
17	76-484	31HP Briggs & Stratton Engine	1
	8983-6	Fire Sleeve	1
	76-463	Foil Face Insulation, 15.5" x 15"	1
	76-464	Foil face Insulation, 19.5" x 22.5"	1
	18-222	Hose Clamp	1
	21-161	Wire Block	1
18	HB-516-18-200	Hex Bolt, 5/16 - 18 x 2	4
	HNTL-516-18	Nylon Lock Nut, 5/16 - 18	4
19	HB-38-16-125	Hex Bolt, 3/8 - 16 x 1¼	4
	HNTL-38-16	Nylon Lock Nut, 3/8 - 16	4
20	76-396	Tailpipe	1
21	76-436	Tailpipe Bracket	1
22	76-404	Motor Mount	1
23	76-410	Tailpipe Shield	1
24	18-116	Hose Clamp	1
25	76-370	Idler Arm	1
26	14-266	Ball Bearing	1
27	48-109	Spring	1
28	HB-38-16-125	Hex Bolt, 3/8 - 16 x 1¼	2
	HW-38	Flat Washer, 3/8	4
	HNTL-38-16	Nylon Lock Nut, 3/8 - 16	2
29	76-407	Pump Mount	1
30	76-401	Shift Arm	1
31	76-482	Hydrostatic Pump	1
	HB-38-16-150	Hex Bolt, 3/8 - 16 x 1½	2
	HW-38	Flat Washer, 3/8	2
	HWL-38	Lock Washer, 3/8	2
32	23-129	Elbow 90°	1
33	23-188	Male Connector, 3/8	1
34	76-637	Pump Mount Shim	1
35	76-466	7/8" Coupling Half	1
	76-467	1¼" Coupling Half	1
	76-468	Sleeve, M42	1

KUBOTA DIESEL ENGINE AND EXHAUST DRAWING

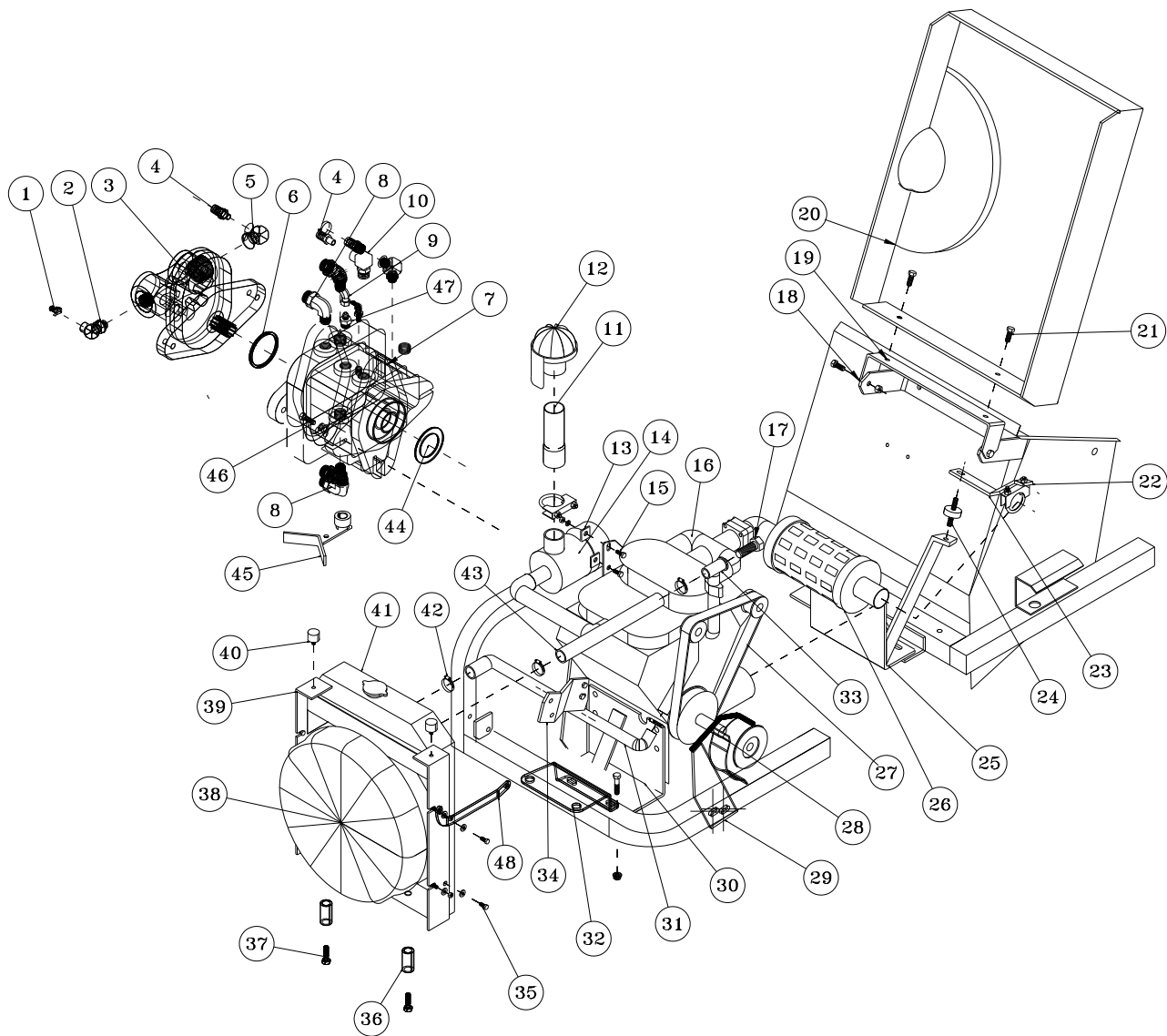

Parts

KUBOTA DIESEL ENGINE AND EXHAUST PARTS LIST

REF#	PART#	DESCRIPTION	QUANTITY
1	23-188	Male Connector, $\frac{3}{8}$	1
2	23-129	Elbow, 90°	1
3	76-197	Gear Pump	1
4	18-133	Barb Fitting	2
5	23-133	Adjustable Elbow, 90°	1
6	23-145	O-Ring	1
7	77-264	Hydrostatic Pump	1
8	18-204	Elbow 90°	2
9	18-202	Elbow	1
10	23-130	Elbow, 90°	1
11	77-249	Diesel Air Intake	1
12	42-004-02	Filter Head	1
13	11-132	Mounting Band (part of engine)	1
	HB-14-20-075	Hex Bolt, $\frac{1}{4}$ - 20 x $\frac{3}{4}$	2
	HWL-14	Lock Washer, $\frac{1}{4}$	2
	HN-14-20	Hex Nut, $\frac{1}{4}$ - 20	2
14†	77-213	Air Cleaner Element (Steel Canister)	1
	42-076-03	Air Cleaner Element (Plastic Canister)	1
15	77-248	Air Cleaner Mount	1
	HSD-8-50	Drill Screw, #8 - 50	2
16	77-208	D-722 Diesel Kubota Engine	1
	77-208-02	Pump Housing	1
	77-208-03	Drive Shaft	1
	22-065	Auxiliary Ground	1
17*	77-208-05	Air Pack Switch (part of engine)	1
18	77-182	Hood Hinge Mount	1
	HB-38-16-100	Hex Bolt, $\frac{3}{8}$ - 16 x 1	4
	HNTL -38-16	Nylon Lock Nut, $\frac{3}{8}$ - 16	4
19	77-236	Hood Hinge	1
20	77-250	Engine Cover	1
	15-437	Latch	1
21	HB-38-16-100	Hex Bolt, $\frac{3}{8}$ - 16 x 1	2
	HN-38-16	Hex Nut, $\frac{3}{8}$ - 16	2
22	50-111	Muffler Clamp, $1\frac{1}{2}$	1
23	77-192	Muffler Brace	1
24	11-021	Rubber Mount	1
25	77-186	Rear Engine Mount	1
	HB-38-16-175	Hex Bolt, $\frac{3}{8}$ - 16 x $1\frac{3}{4}$	2
	HNTL-38-16	Nylon Lock Nut, $\frac{3}{8}$ - 16	2
26	77-216	Muffler Assembly (part of engine)	1
	77-217	Muffler Gasket (part of engine)	1
27	77-212	Fan Belt (part of engine)	1
28	HWK-14-100	Woodruff Key, $\frac{1}{4}$ x 1	1
	77-242	Stub Shaft	1
	HWLI-516	Internal Lock Washer, $\frac{5}{16}$	3
	HSSHSM-8-1.25-20	Socket Set Cap Screw Metric, 8 - 1.25 x 20	3
29		Main Frame	1
*	77-235	Thermostat Kit (includes * items)	
†	77-221	Air Cleaner Assembly	

(Continued on Next Page)

KUBOTA DIESEL ENGINE AND EXHAUST DRAWING (CONTINUED)

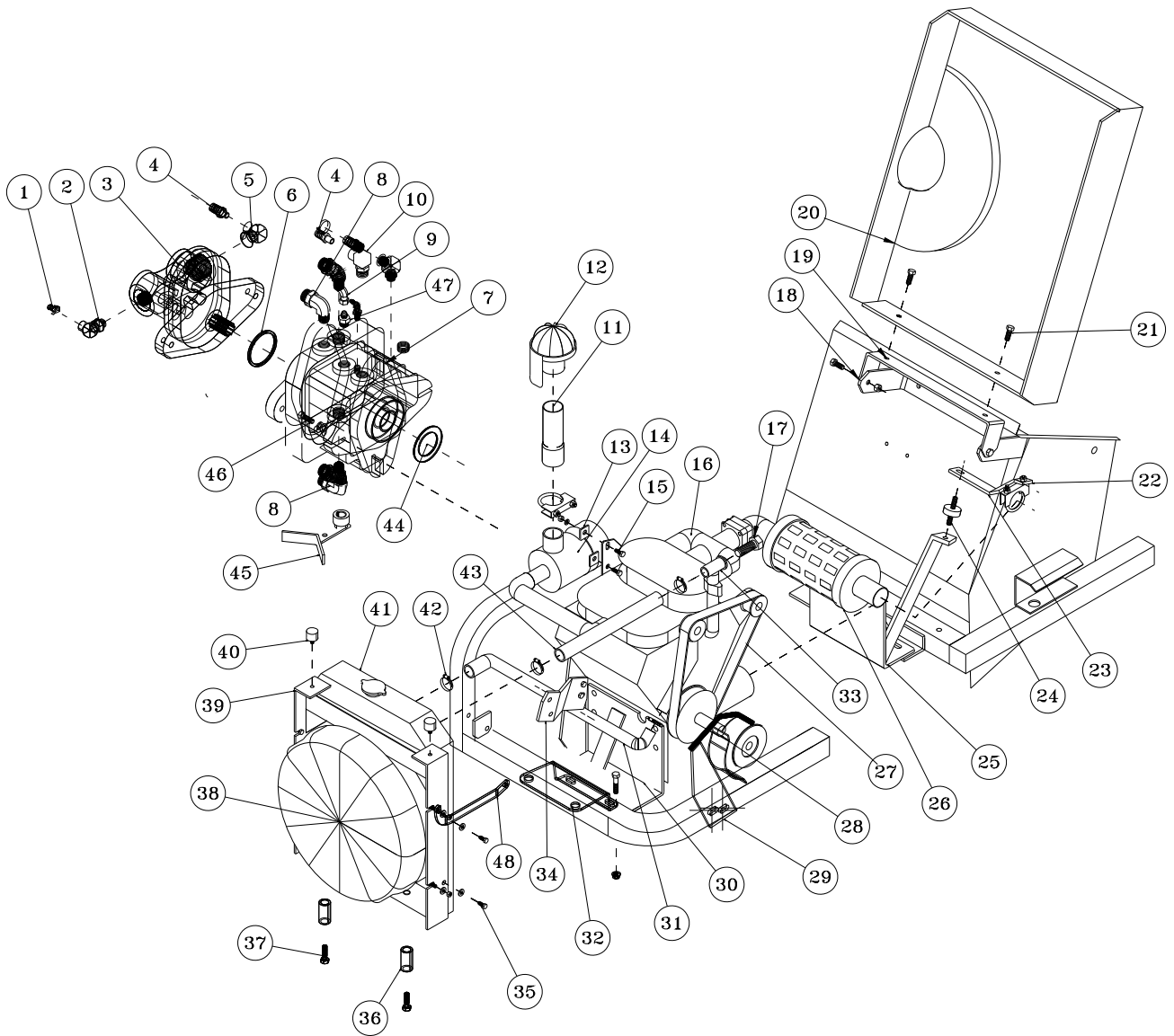

Parts

KUBOTA DIESEL ENGINE AND EXHAUST PARTS LIST (CONTINUED)

REF#	PART#	DESCRIPTION	QUANTITY
30	77-185	Front Engine Mount	1
	HB-38-16-175	Hex Bolt, $\frac{3}{8}$ - 16 x $1\frac{3}{4}$	2
	HNTL-38-16	Nylon Lock Nut, $\frac{3}{8}$ - 16	2
31	8951-24	Lower Radiator Hose	1
32	77-243	Radiator Mount	1
33*	77-208-04	Goose Neck (part of engine)	1
34	77-184	Cable Bracket	1
	HBM-8-1.25 x 20	Metric Hex Bolt, #8 - 1.25 x 20	1
35	HBM-6-1-16	Metric Hex Bolt, #6 - 1 - 16	3
	HBM-6-1-20	Metric Hex Bolt, #6 - 1 - 20	1
	HW-14	Flat Washer, $\frac{1}{4}$	4
	HWLM-6	Metric Lock Washer, #6	4
36	60-406	Spacer	2
37	HBM-10-1.25-110	Metric Hex Bolt, 10 - 1.25 x 110	2
38	77-201	Electric Fan	1
39	77-238	Radiator Mount	1
	15-437	Latch	1
40	15-013	Rubber Bumper	2
	HWL-14	Lock Washer, $\frac{1}{4}$	2
	HN-14-20	Hex Nut, $\frac{1}{4}$ - 20	2
41	77-210	Radiator (on engine)	1
42	18-222	Hose Clamp, $\frac{13}{16}$ to $1\frac{1}{2}$	4
43	8951-11.5	Upper Radiator Hose	1
44	23-145	O-Ring, $3\frac{1}{4}$ ID x $3\frac{3}{8}$ OD	1
	77-208-06	Coupler	1
	77-208-07	Flnage. Polymer	1
45	77-241	Shift Arm	1
	HSSHS-516-18-050	Socket Head Set Screw $\frac{5}{16}$ - 18 x $\frac{1}{2}$	1
46	HB-38-16-125	Hex Bolt, $\frac{3}{8}$ - 16 x $1\frac{1}{4}$	2
-	HW-38	Flat Washer, $\frac{3}{8}$	2
	HWL-38	Lock Washer, $\frac{3}{8}$	2
47	18-241	Straight Thread Connector	1
48	77-237	Radiator Brace	1
*	77-235	Thermostat Kit (includes * items)	

ELECTRIC CLUTCH DRIVEN BELT DRIVE DRAWING

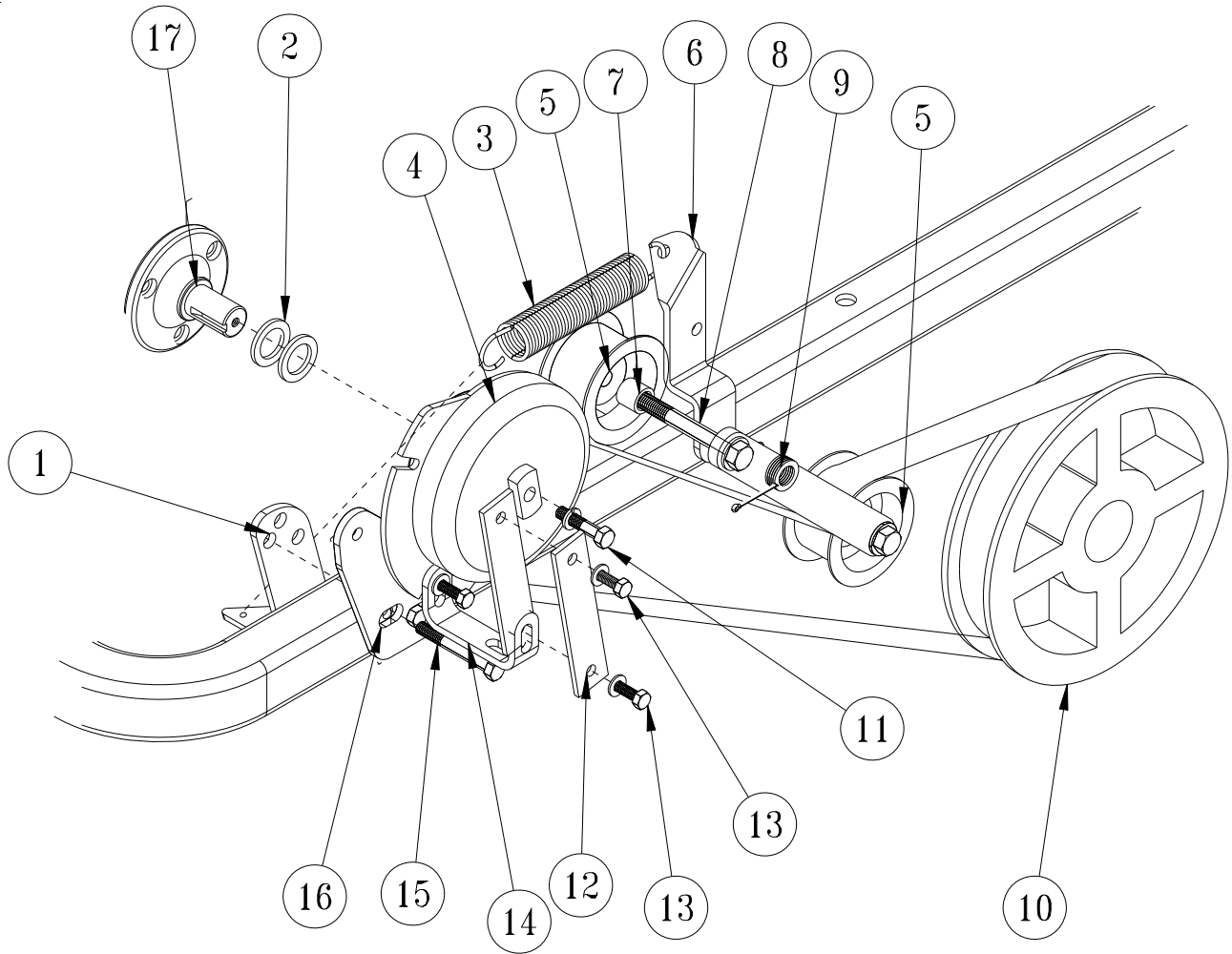

Parts

ELECTRIC CLUTCH DRIVEN BELT DRIVE PARTS LIST

REF#	PART#	DESCRIPTION	QUANTITY
1	48-038	Spring Bracket	1
2	HMB-100-10	Machine Bushing, 1 x 10GA	2
3	21-445	Spring	1
	9020-8.5	Heat Shrink Tubing	1
4	76-412	Electric Clutch (Gas)	1
	76-337	Electric Clutch (Diesel)	1
	17-271	Pigtail (Diesel)	1
5	16-013	Idler Pulley	2
6	76-217	Idler Arm	1
7	76-298	Spacer	2
8	HB-12-13-400	Hex Bolt, $\frac{1}{2}$ - 13 x 3	2
	HW-12	Flat Washer, $\frac{1}{2}$	2
	HNTL-12-13	Nylon Lock Nut, $\frac{1}{2}$ - 13	2
9	HMB-12-14	Machine Bushing, $\frac{1}{2}$ x 14GA	5
	HP-18-150	Cotter Pin, $\frac{1}{8}$ x $1\frac{1}{2}$	1
10	76-102	Pulley, 2AK104H	1
	76-102-01	Hub, $1\frac{1}{4}$ ID	1
	HKSQ-14-150	Machine Key, $\frac{1}{4}$ x $\frac{1}{4}$ x $1\frac{1}{2}$	1
	76-200	Belt, 2/A74	1
11	HB-38-16-175	Hex Bolt, $\frac{3}{8}$ - 16 x $1\frac{3}{4}$	1
	HWL-38	Lock Washer, $\frac{3}{8}$	1
12	76-340	Clutch Strap	2
13	HB-516-18-100	Hex Bolt, $\frac{5}{16}$ - 18 x 1	3
	HW-516	Washer, $\frac{5}{16}$	3
	HNTL-516-18	Nylon Lock Nut, $\frac{5}{16}$ - 18	3
14	76-409	Belt Guard Support (Gas)	1
	76-339	Belt Guard Support (Diesel)	1
15	HB-38-16-300	Hex Bolt, $\frac{3}{8}$ - 16 x 3	2
	HNTL-38-16	Nylon Lock Nut, $\frac{3}{8}$ - 16	2
16	76-408	Clutch Mount (Gas)	1
	76-338	Clutch Mount (Diesel)	1
17	76-411	Stub Shaft (Gas)	1
	77-242	Stub Shaft (Diesel)	1

FINGER/BRUSH REEL DRAWING

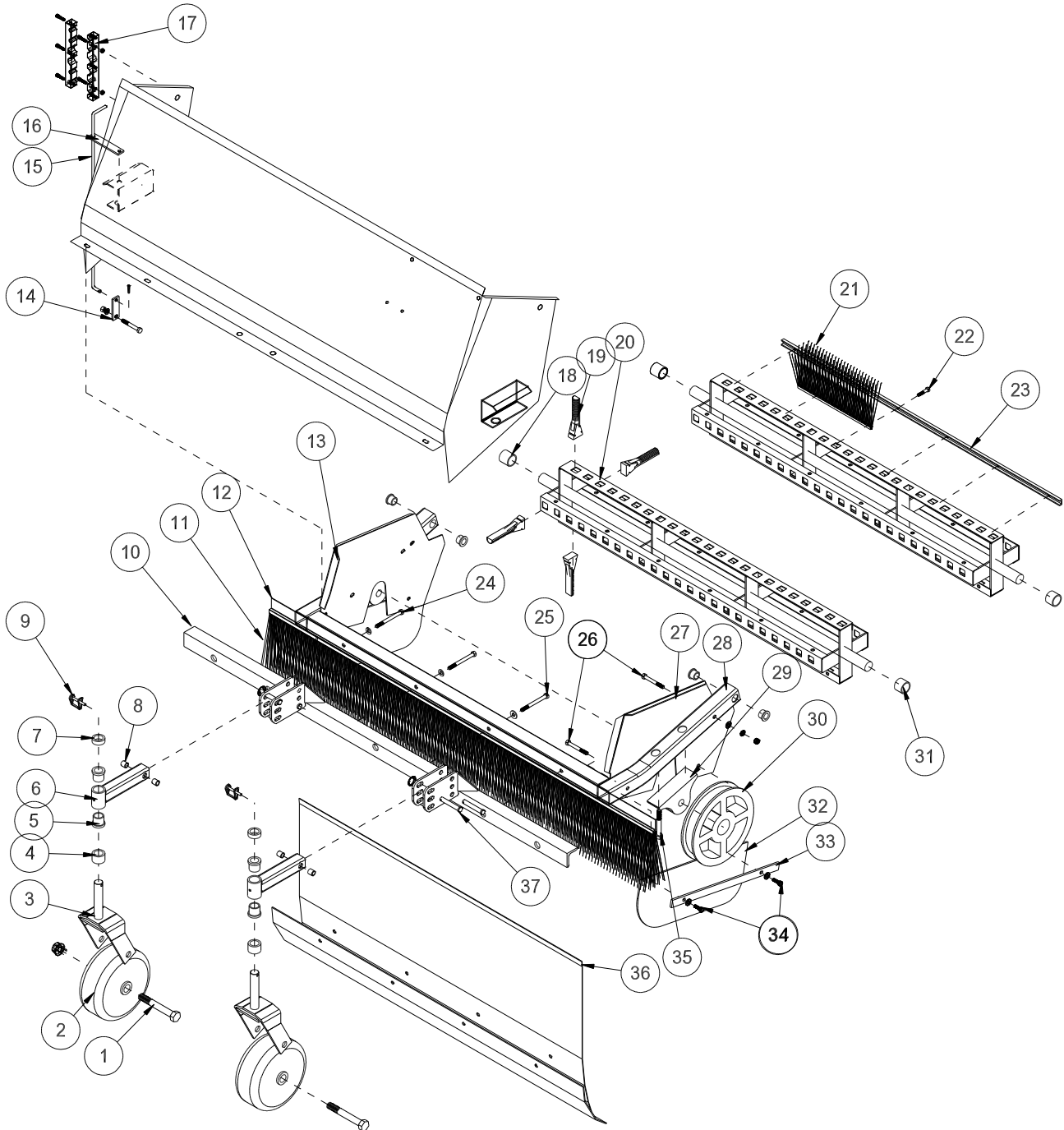

PARTS

FINGER /BRUSH REEL PARTS LIST

REF#	PART#	DESCRIPTION	QUANTITY
1	HB-34-10-550	Hex Bolt, $\frac{3}{4}$ - 10 x $5\frac{1}{2}$	2
	HNTL-34-10	Nylon Lock Nut, $\frac{3}{4}$ - 10	2
2	33-435	Tire and Wheel	2
	33-435-02	Wheel with Roller Bearing	
	33-435-03	Roller Bearing	
	33-435-04	Bushing	
3	48-046	Castor Fork	2
	HMB-100-10	Machine Bushing, 1 x 10GA	4
4	29-585	Spacer Height Adjustment	2
5	18-223	Bushing (part of 76-355)	2 per
6	76-355	Arm	2
7	29-584	Height Adjustment Spacer, $\frac{1}{2}$ "	2
8	20-019	Bushing (part of 76-355)	2 per
9	29-541	Lock Pin $\frac{1}{4}$	2
10	76-356	Castor Mount Bracket	1
	HCP-12-250	Clevis Pin $\frac{1}{2}$ x $2\frac{1}{2}$	4
	78-463	Kick-out Ring	4
11	76-439	Brush	1
12	76-438	Brush Channel	1
13	75-799	Side Plate RH.	1
14	76-278	Bottom Mount	1
	HB-38-16-300	Hex Bolt, $\frac{3}{8}$ - 16 x 3	1
	HNTL-38-16	Nylon Lock Nut, $\frac{3}{8}$ -16	1
15	76-277	Height Indicator Rod	1
16	76-279	Top Mount	1
17	76-336	Hose Clamp	1
18	75-686	Spacer, $1\frac{1}{4}$ ID x $1\frac{3}{8}$	1
19	75-506	Sweeper Finger	116
20	75-780	Finger Reel	1
21	76-330	Brush	4
22	HB-516-18-125	Hex Bolt, $\frac{5}{16}$ - 18 x $1\frac{1}{4}$	28
	HNTL-516-18	Nylon Lock Nut, $\frac{5}{16}$ - 18	28
23	76-313	Clamp	4
24	HB-38-16-350	Hex Bolt, $\frac{3}{8}$ - 16 x $3\frac{1}{2}$	2
	HW-38	Flat Washer, $\frac{3}{8}$	4
	HNTL-38-16	Nylon Lock Nut, $\frac{3}{8}$ - 16	2
25	HB-38-16-400	Hex Bolt, $\frac{3}{8}$ - 16 x 4	1
	HW-38	Flat Washer, $\frac{3}{8}$	2
	HNTL-38-16	Nylon Lock Nut, $\frac{3}{8}$ - 16	1
26	HB-38-16-350	Hex Bolt, $\frac{3}{8}$ - 16 x $3\frac{1}{2}$	1
	HB-38-16-275	Hex Bolt, $\frac{3}{8}$ - 16 x $2\frac{3}{4}$	7
	HNTL-38-16	Nylon Lock Nut $\frac{3}{8}$ - 16	4
27	75-800	Left Side Plate	1
28	75-787	Reel Frame	1
	18-221	Flange Bushing(part of 75-787)	4
29	75-511	Pillow Block, $1\frac{1}{4}$ Bore	2
30	76-102	Pulley with Hub	1
	76-102-01	Hub, $1\frac{1}{4}$ ID	1
	HMB-114-10	Machine Bushing, $1\frac{1}{4}$ x 14 GA	1 As Req'd
31	75-834	Spacer, $1\frac{1}{4}$ ID x $1\frac{1}{8}$	1
32	76-210	Matting, $7\frac{1}{2}$ x 18	2
33	76-213	Reel Guard Strap	2
34	HB-516-18-100	Hex Bolt, $\frac{5}{16}$ - 18 x 1	4
	HNTL-516-18	Nylon Lock Nut, $\frac{5}{16}$ - 18	4
35	HB-12-13-350	Hex Bolt, $\frac{1}{2}$ - 13 x $3\frac{1}{2}$	4
	HMB-12-14	Machine Bushing, $\frac{1}{2}$ - 14	4
	HNTL-12-13	Nylon Lock Nut, $\frac{1}{2}$ - 13	4
36	75-808	Front Baffle	1
37	HCP-12-250	Clevis Pin, $\frac{1}{2}$ x $2\frac{1}{2}$	4
	76-483	Knockout Ring	4

REAR AXLE DRAWING

PARTS

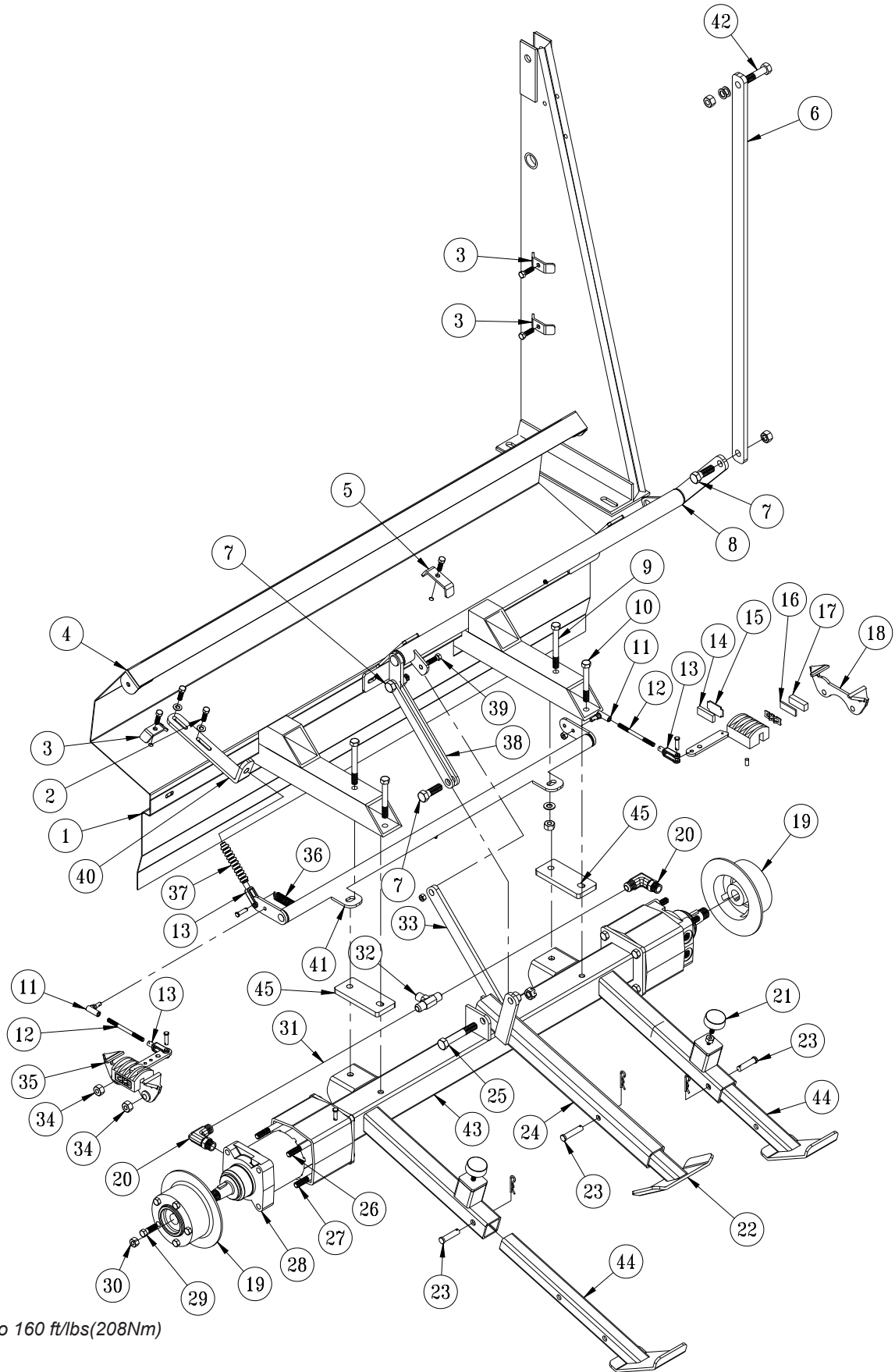

Torque to 160 ft/lbs(208Nm)

REAR AXLE PARTS LIST

REF#	PART#	DESCRIPTION	QUANTITY
1	76-233	Rear Beater Panel	1
2	HB-38-16-125	Hex Bolt, $\frac{3}{8}$ - 16 x $1\frac{1}{4}$	2
	HW-38	Flat Washer, $\frac{3}{8}$	4
	HNTL-38-16	Nylon Lock Nut, $\frac{3}{8}$ - 16	2
3	13-099	Hose Clamp	3
	HB-516-18-125	Hex Bolt, $\frac{5}{16}$ - 18 x $1\frac{1}{4}$	2
	HWL-516	Lock Washer, $\frac{5}{16}$	2
	HB-516-18-150	Hex Bolt, $\frac{5}{16}$ - 18 x $1\frac{1}{2}$	1
	HNTL-516-18	Nylon Lock Nut, $\frac{5}{16}$ - 18	1
4	76-234	Rear Chute Baffle	1
	8947-60	Trim Seal, x 60"	1
5	75-614	Hose Clamp	1
	HB-516-18-150	Hex Bolt, $\frac{5}{16}$ - 18 x $1\frac{1}{2}$	1
	HNTL-516-18	Nylon Lock Nut, $\frac{5}{16}$ - 18	1
6	76-386	Long Linkage Strap	1
7	HB-58-11-200	Hex Bolt, $\frac{5}{8}$ - 11 x 2	3
	HNTL-58-11	Nylon Lock Nut, $\frac{5}{8}$ - 11	3
8	76-387	Rear Skid Pivot	1
9	HB-12-13-450	Hex Bolt, $\frac{1}{2}$ - 13 x 4 $\frac{1}{2}$	2
	HNTL-12-13	Nylon Lock Nut, $\frac{1}{2}$ - 13	2
10	HB-12-13-450	Hex Bolt, $\frac{1}{2}$ - 13 x 4 $\frac{1}{2}$	2
11	21-462	Ball Joint, $\frac{5}{16}$ - 24	2
12	76-300	Brake Rod	2
	HN-516-24	Hex Nut, $\frac{5}{16}$ - 24	4
13	11-100	Linkage Yoke, $\frac{5}{16}$	3
	HCP-516-100	Clevis Pin, $\frac{5}{16}$ x 1	3
	HP-18-075	Cotter Pin, $\frac{1}{8}$ x $\frac{3}{4}$	3
14*		Carrier Side Pad	1
15*		Carrier Side Pad Support	1
16*		Cam Side Pad Support	1
17*		Cam Side Pad	1
18	76-241	Right Caliper Clockwise	1
	HN-516-24	Hex Nut, $\frac{5}{16}$ - 24	1
19	76-239	Brake Disk, 8" 5 Hole	2
20	34-122	Short 90° Elbow	4
21	50-081	Rubber Bumper	2
	HN-38-16	Hex Nut, $\frac{3}{8}$ - 16	2
22	48-039	Rear Skid	1
23	HCP-12-225	Clevis Pin, $\frac{1}{2}$ x $2\frac{1}{4}$	4
	HHP-18	Bridge Pin, $\frac{1}{8}$	4
24	48-040	Rear Skid Arm	1
25	HB-58-11-400	Hex Bolt, $\frac{5}{8}$ - 11 x 4	1
	HNTL-58-11	Nylon Lock Nut, $\frac{5}{8}$ - 11	1
26	HB-12-13-800	Hex Bolt, $\frac{1}{2}$ - 13 x 8	4
27	HB-12-13-750	Hex Bolt, $\frac{1}{2}$ - 13 x $7\frac{1}{2}$	4
	HMB-12-14	Machine Bushing, $\frac{1}{2}$ x 14GA	4
	HNFL-12-13	Flange Nylon Lock Nut, $\frac{1}{2}$ - 13	8
*	34-101-02	Pad Kit with 2 Pads and Steel Backing Plates	2 Kits Req'd per Axle
	34-101-01	Pads Only	

(Continued on Next Page)

REAR AXLE DRAWING

PARTS

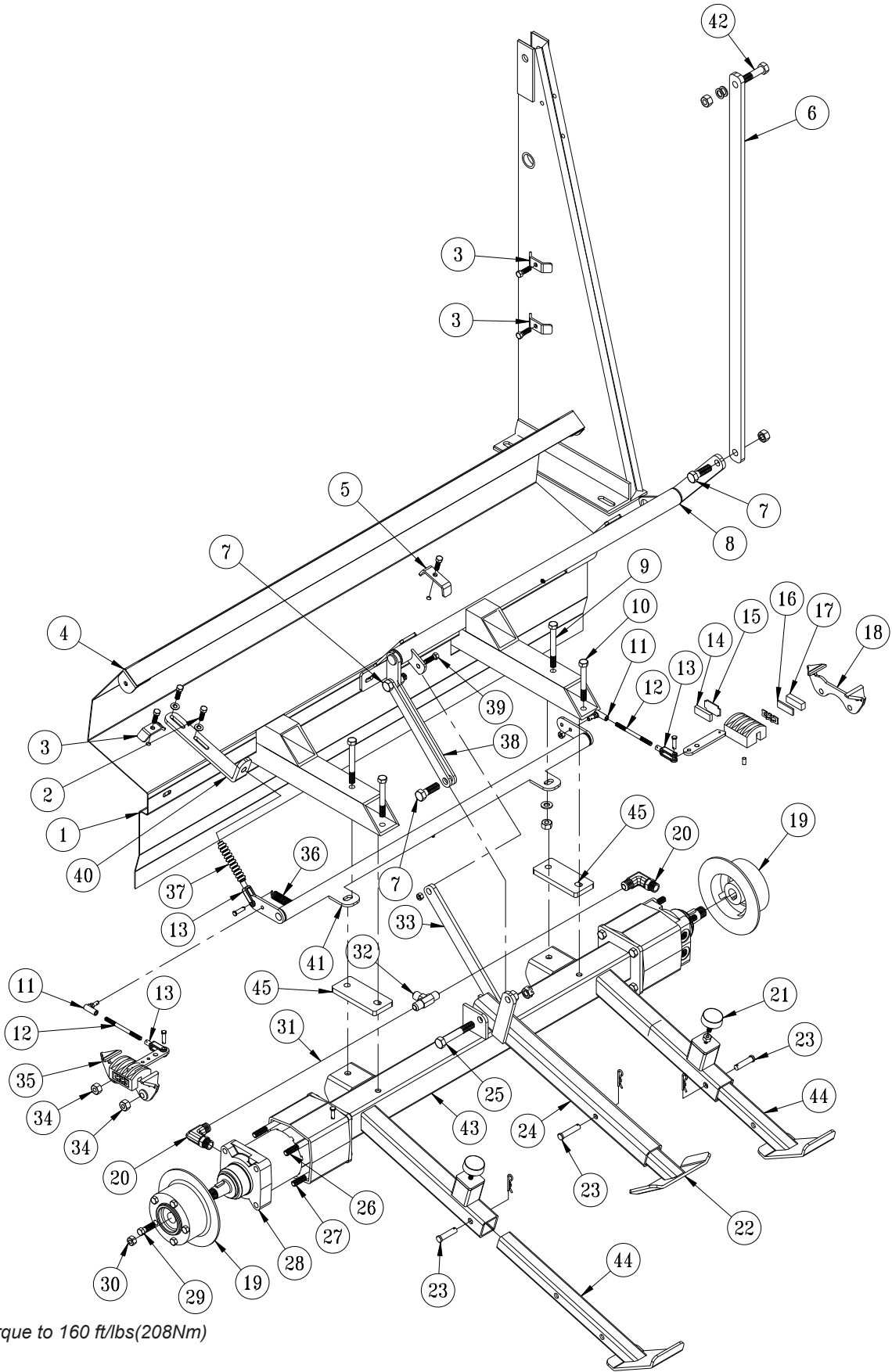

Torque to 160 ft/lbs(208Nm)

REAR AXLE PARTS LIST

REF#	PART#	DESCRIPTION	QUANTITY
28	76-238	Wheel Motor	2
	HWK-516-100	Woodruff Key, $\frac{5}{16}$ x 1	2
29	60-268	Lug Nut, $\frac{1}{2}$ - 20 x $1\frac{5}{16}$	10
30	14-265	Nut, 1 - 20	2
31	76-208	Hydraulic Hose, 23.5"	4
32	34-057	Tee Fitting	2
33	76-385	Brace	2
34	HNTL-12-13	Nylon Lock Nut, $\frac{1}{2}$ - 13	4
35	76-240	Left Caliper Counterclockwise	1
36	29-118	Zinc Plated Spring	1
37	60-536	Bellows	2
	76-225	Brake Cable with Nuts	1
38	48-042	Linkage Strap Short	1
39	HB-38-16-125	Hex Bolt, $\frac{3}{8}$ - 16 x $1\frac{1}{4}$	1
	HNTL-38-16	Nylon Lock Nut, $\frac{3}{8}$ - 16	1
40	76-218	Brake Cable Bracket	1
41	76-229	Park Brake Relay	1
42	HB-58-18-325	Hex Bolt, $\frac{5}{8}$ - 18 x $3\frac{1}{4}$	1
	HMB-58-14	Machine Bushing, $\frac{5}{8}$ x 14GA	2
	HNCL-58-18	Center Nut, $\frac{5}{8}$ - 18	1
43	76-226	Rear Axle	1
44	75-723	Rear Skid	2
45	76-639	Axle Shim	2
*	34-101-02	Pad Kit with 2 Pads and Steel Backing Plates	2 Kits Req'd per Axle
	34-101-01	Pads Only	

HOPPER DRAWING

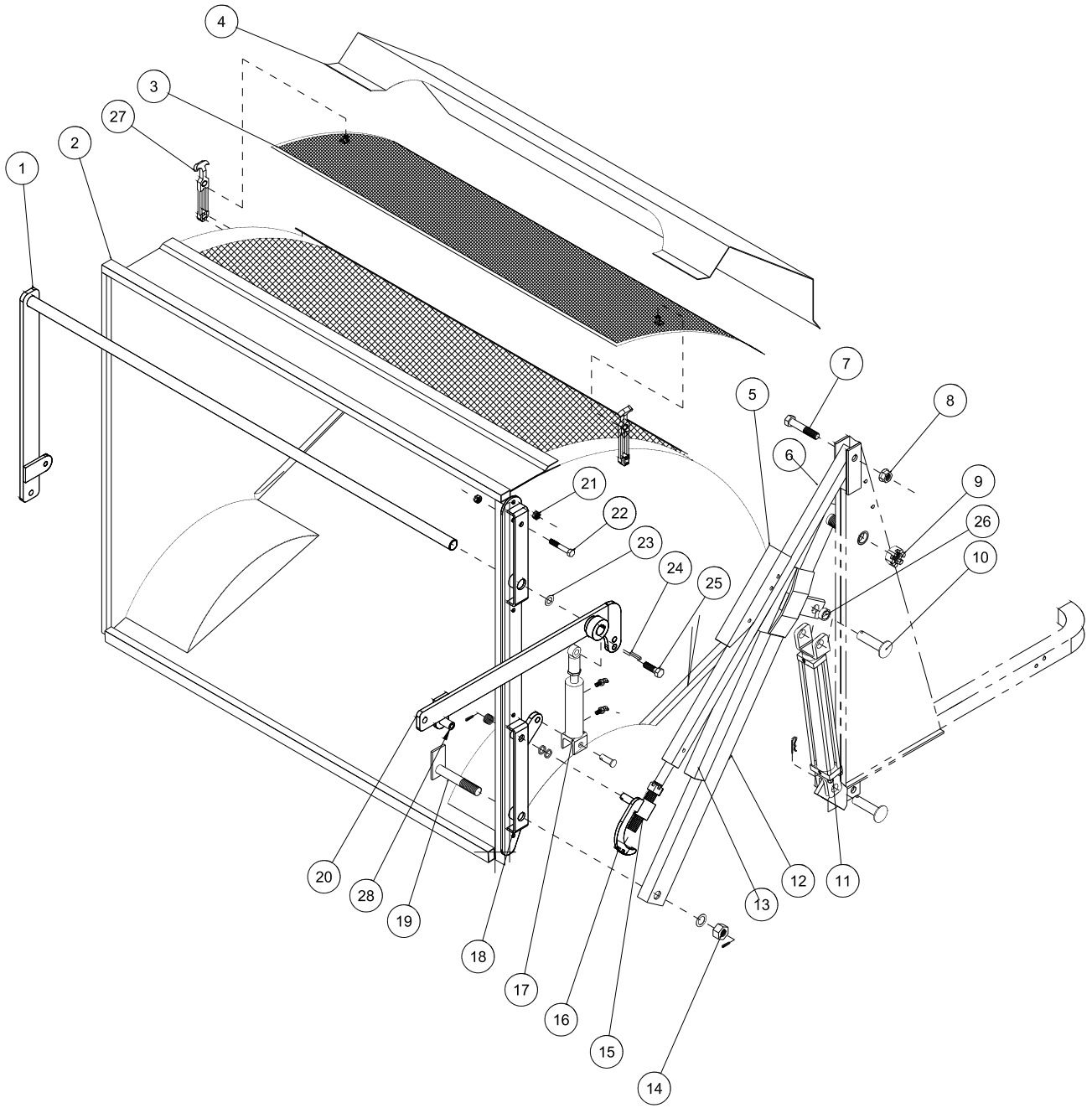

Parts

HOPPER PARTS LIST

REF#	PART#	DESCRIPTION	QUANTITY
1	76-414	Left Tailgate Dump Bar	1
	HMB-114-10	Machine Bushing, 1 ¹ / ₄ x 10 GA	1
2	76-237	Hopper	1
3	76-261	Hopper Screen	1
4	76-359	Hopper Screen Cover	1
	HB-516-18-075	Hex Bolt, 5 ⁵ / ₁₆ - 18 x 3 ³ / ₄	6
	HW-516	Flat Washer, 5 ⁵ / ₁₆	6
	HNTL-516-18	Nylon Lock Nut, 5 ⁵ / ₁₆ - 18	6
5	75-653	Hopper Safety Lift	2
	HB-38-16-225	Hex Bolt, 3 ³ / ₈ - 16 x 2 ¹ / ₄	4
	HNW-38-16	Wing Nut, 3 ³ / ₈ - 16	4
6	76-230	Hopper Dump Arm	2
	HNA-100-14	Slotted Hex Nut, 1 - 14	2
7	HB-34-10-400	Hex Bolt, 3 ³ / ₄ - 10 x 4	2
	HMB-34-14	Machine Bushing, 3 ³ / ₄ - 14GA	2
8	HNTL-34-10	Nylon Lock Nut, 3 ³ / ₄ - 10	2
9	HNAT-114-12	Thick Axle Nut, 1 ¹ / ₄ - 12	2
	HP-316-100	Cotter Pin, 3 ³ / ₁₆ x 1	2
10	HCP-100-325	Clevis Pin, 1 x 3 ¹ / ₄	2
	HHP-.177	Bridge Pin	2
11	76-242	Hydraulic Cylinder	2
12	76-211	Arm Pivot Tube	1
	76-161	Hose Guard, Short	1
13	76-159	Hose Guard, Long	1
14	HMB-100-14	Machine Bushing, 1 x 14GA	2
	HNA-100-14	Slotted Hex Nut, 1 - 14	2
	HP-18-150	Cotter Pin, 1 ¹ / ₈ x 1 ¹ / ₂	2
15	48-148	Right Adjustment Sleeve (shown)	1
	48-153	Left Adjustment Sleeve	1
	HMB-34-14	Machine Bushing, 3 ³ / ₄ x 14GA	2
	HMB-34-10	Machine Bushing, 3 ³ / ₄ x 10GA	8
	HP-18-150	Cotter Pin, 1 ¹ / ₈ x 1 ¹ / ₂	2
16	75-704	Castle Nut, 1 - 14	2
17	77-263	Hydraulic Cylinder, 1 ¹ / ₂ x 7	1
	18-168	Elbow	2
	18-154	Rod End	1
	HG-14-28-180	Grease Fitting, 1 ¹ / ₄ - 28 x 180° (part of rod end)	1
	HCP-58-150	Clevis Pin, 5 ⁵ / ₈ x 1 ¹ / ₂	1
	HHP-18	Bridge Pin, 1 ¹ / ₈	1
18	76-215	Right Hinge Strap (Shown)	1
	76-216	Left Hinge Strap	1
19	75-569	Swivel Pin	2
20	76-413	Right Tailgate Dump Bar	1
21	HNCL-38-16	Center Nylon Lock Nut, 3 ³ / ₈ - 16	8
	HB-38-16-075	Hex Bolt, 3 ³ / ₈ - 16 x 3 ³ / ₄	8
22	HB-12-13-300	Hex Bolt, 1 ¹ / ₂ - 13 x 3	2
	HN-12-13	Nut 1 ¹ / ₂ - 13	2
	HNCL-12-13	Center Nylon Lock Nut 1 ¹ / ₂ - 13	2

(Continued on next page)

HOPPER DRAWING

PARTS

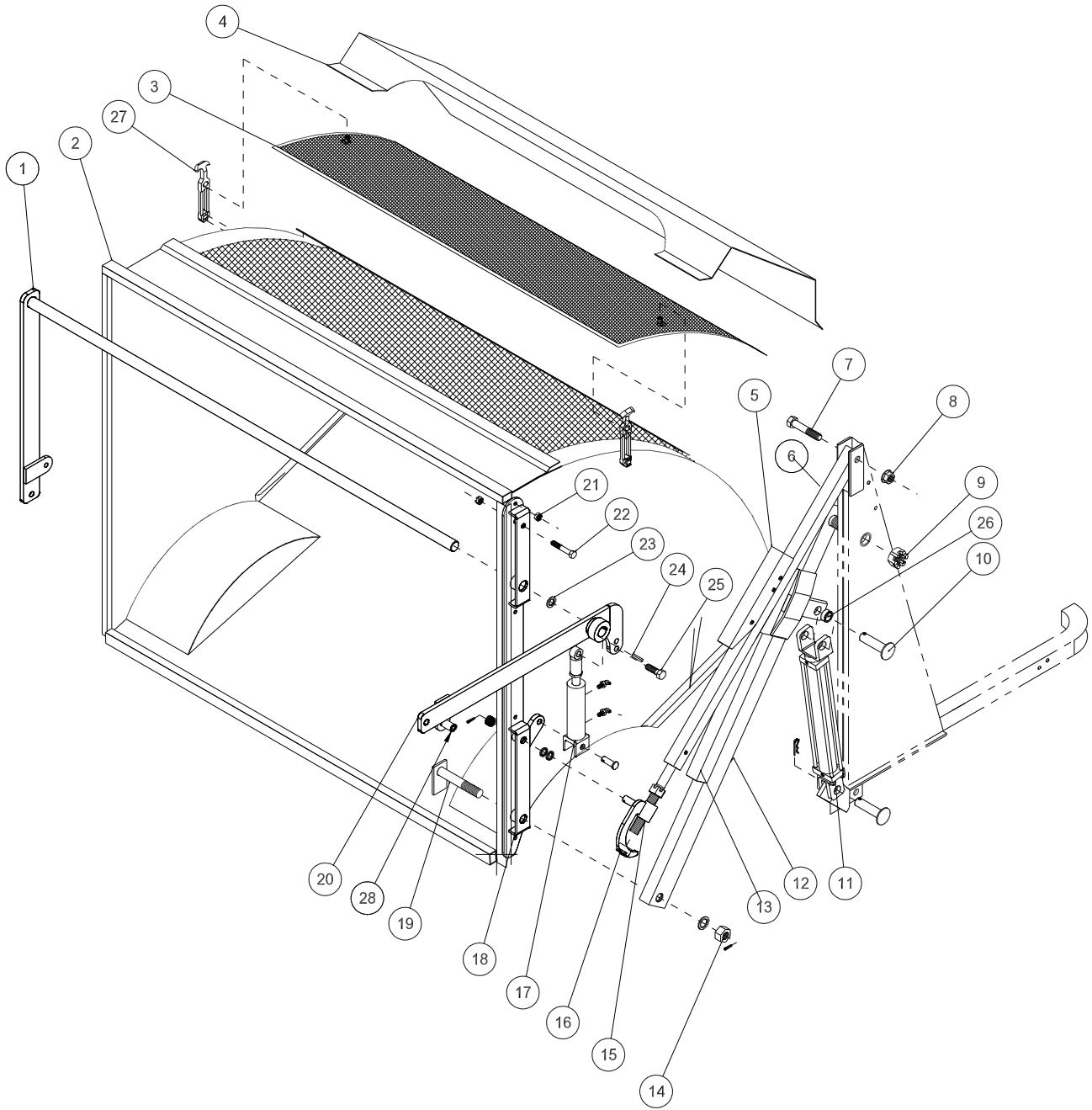

HOPPER PARTS LIST

REF#	PART#	DESCRIPTION	QUANTITY
23	HMB-114-10	Machine Bushing, 1 ¹ / ₄ x 10GA	2 As Req'd
24	HKSQ-14-150	Machine Key, 1 ¹ / ₄ x 1 ¹ / ₄ x 1 ¹ / ₂	1
	HSSHS-516-18-038	Set Screw, 5 ¹ / ₁₆ - 18 x 3 ³ / ₈	1
	HRP-38-250	Roll Pin, 3 ³ / ₈ x 2 ¹ / ₂	1
25	HB-58-11-200	Hex Bolt, 5 ⁵ / ₈ - 11 x 2	1
	HMB-58-14	Machine Bushing, 5 ⁵ / ₈ x 14GA	3
	HNCL-58-11	Center Nylon Lock Nut, 5 ⁵ / ₈ - 11	1
*26	76-288	Spacer	2
27	15-437	Latch	2
	HRS-316-1125	Rivet, 3 ³ / ₁₆ x 1 ¹ / ₈	4
	HRW-316	Rivet Washer, 3 ³ / ₁₆	6
	HW-316	Flat Washer, 3 ³ / ₁₆	4
28	42-702	Spacer	2
	HB-12-13-250	Hex Bolt, 1 ¹ / ₂ - 13 x 2 ¹ / ₂	2
	HNCL-12-13	Center Nylon Lock Nut, 1 ¹ / ₂ - 13	2

*Spacer **MUST** be to the outside of the tab on the Pivot Arm with the tab and the spacer inside the cylinder yoke.

TAILGATE DRAWING

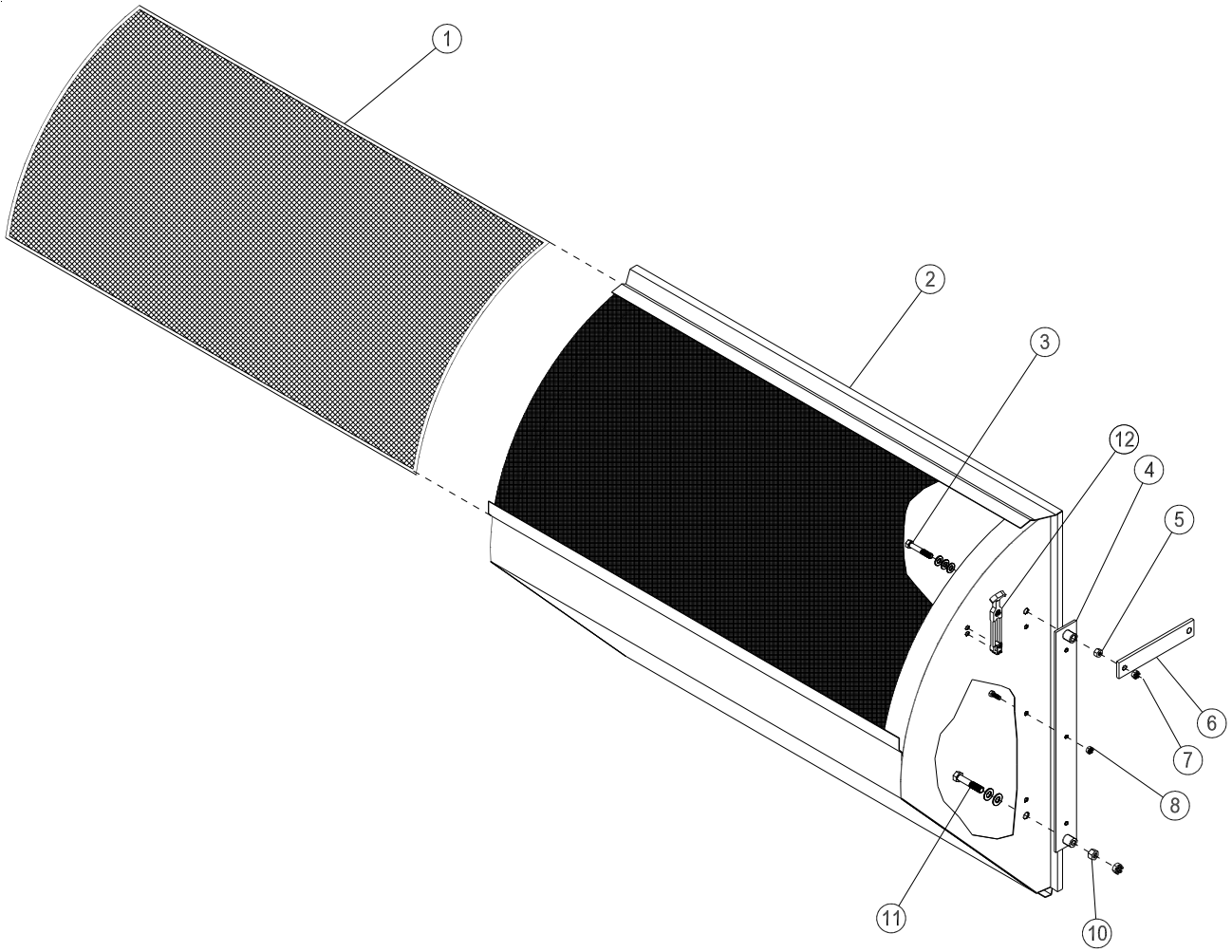

Parts

TAILGATE PARTS LIST

REF#	PART#	DESCRIPTION	QUANTITY
1	76-262	Tailgate Screen	1
2	76-243	Tailgate	1
3	HB-12-13-300	Hex Bolt, 1/2 - 13 x 3	2
	HMB-12-14	Machine Bushing, 1/2 x 14GA	6
4	75-565	Tailgate Hinge Strap	2
5	HN-12-13	Hex Nut, 1/2 - 13	2
6	75-564	Tailgate Hinge	2
7	HNCL-12-13	Center Nylon Lock Nut, 1/2 - 13	2
8	HNTL-38-16	Nylon Lock Nut, 3/8 - 16	6
	HB-38-16-100	Hex Bolt, 3/8 - 16 x 1	6
10	HNJ-58-18	Jam Nut, 5/8 - 18	9
11	HB-58-18-325	Hex Bolt, 5/8 - 18 x 3 1/4	2
	HMB-58-14	Machine Bushing, 5/8 x 14GA	10
12	15-437	Latch	2
	HRS-316-1125	Rivet Steel, 3/16 x 1 1/8	4
	HRS-316-100	Rivet Steel, 3/16 x 1	2
	HRW-316	Rivet Washer, 3/16	4
	HW-316	Flat Washer, 3/16	2
NS	8828-60	Weather Stripping (60")	1

77-264 EATON HYDROSTATIC PUMP DRAWING (DIESEL)

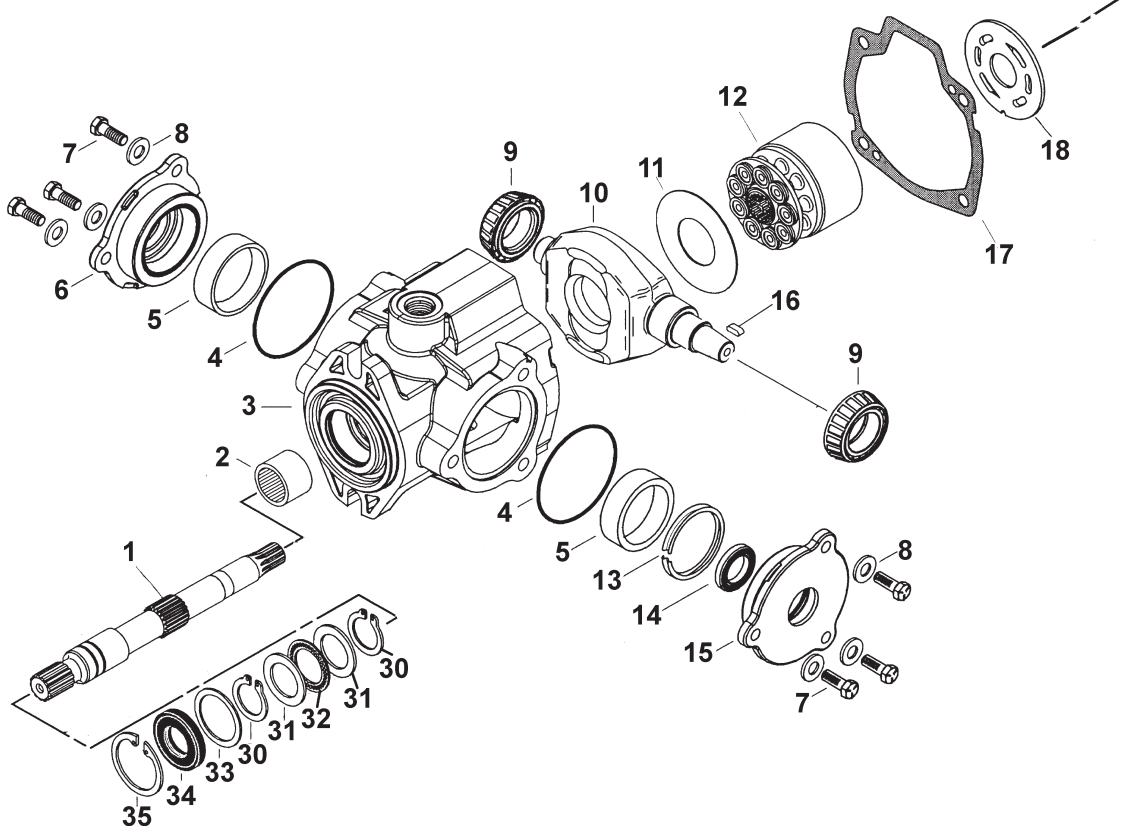
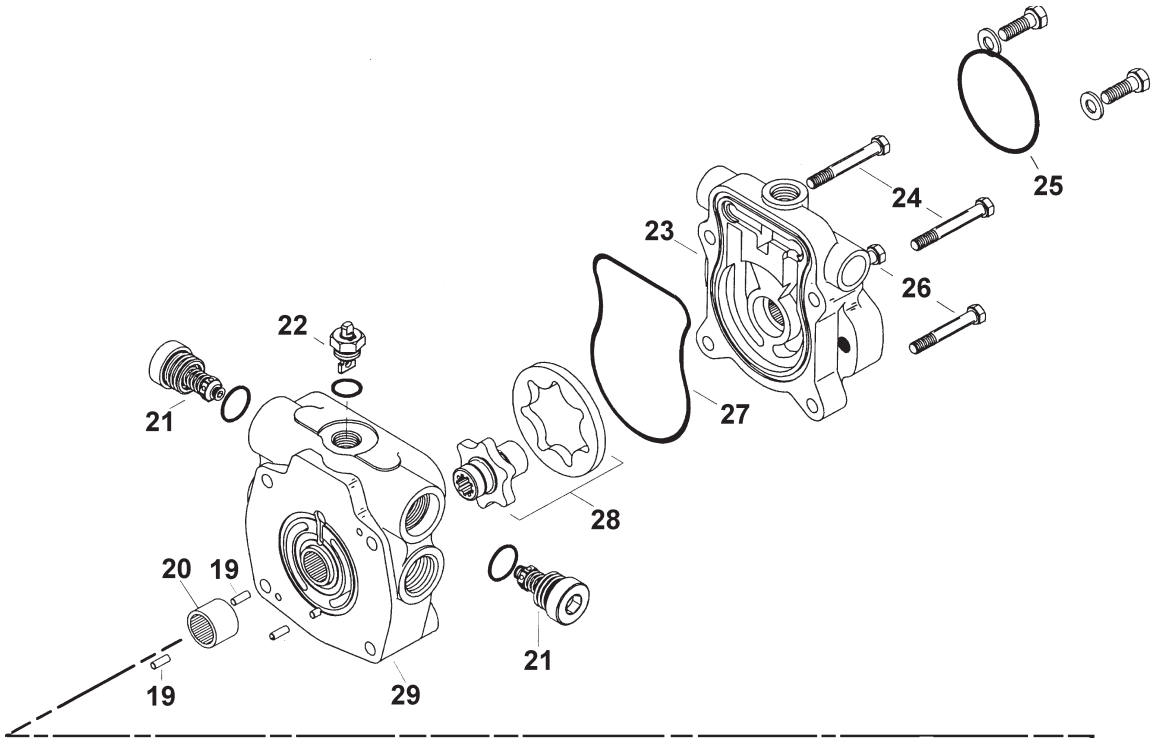

Parts

77-264 EATON HYDROSTATIC PUMP PARTS LIST (DIESEL)

REF#	PART#	DESCRIPTION	QUANTITY
1	60-343-52	Drive Shaft (splined)	1
2	60-343-08	Needle Bearing (with housing)	1
3	77-239-01	Housing	1
4	77-239-02	O-Ring	1
5	77-239-03	Thrust Bearing	2
6	77-239-04	Trunnion Cover	1
7	77-239-05	Pan Head Screw	2
8	77-239-06	Washer	6
9	77-239-07	Cone Bearing	2
10	77-239-08	Cam Plate	1
11	77-239-09	Swash Plate Insert	1
12	60-343-21	Rotating Kit	1
13	77-239-10	Crush Ring	1
14*	60-343-12	Shaft Seal	1
15	77-239-11	Seal Cover	1
16	77-239-12	Key	1
17*	77-239-13	Gasket	1
18	76-482-01	Valve Plate	1
19	33-058-27	Dowel Pin	2
20	60-343-23	Bearing	1
21	77-239-15	Relief Valve (4000 psi)	2
22	77-239-16	Tow Valve Assembly	1
23		Charge Pump Adapter	1
24	77-239-17	Cap Screw	2
25*	77-130	O-Ring (mounting kit)	1
26	77-239-18	Cap Screw	2
27*	77-239-19	O-Ring	1
28		Gerotor and Coupler	1
29	77-239-20	End cover Assembly	1
30*	77-239-21	Retaining Ring	2
31	60-343-05	Bearing Race	1
32	60-343-06	Thrust Bearing	1
33	60-343-03	Washer	2
34*	60-343-02	Shaft Seal	1
35*	60-343-01	Retaining Ring	1

* 77-239-23 Seal Repair Kit

76-482 EATON HYDROSTATIC PUMP DRAWING (GAS)

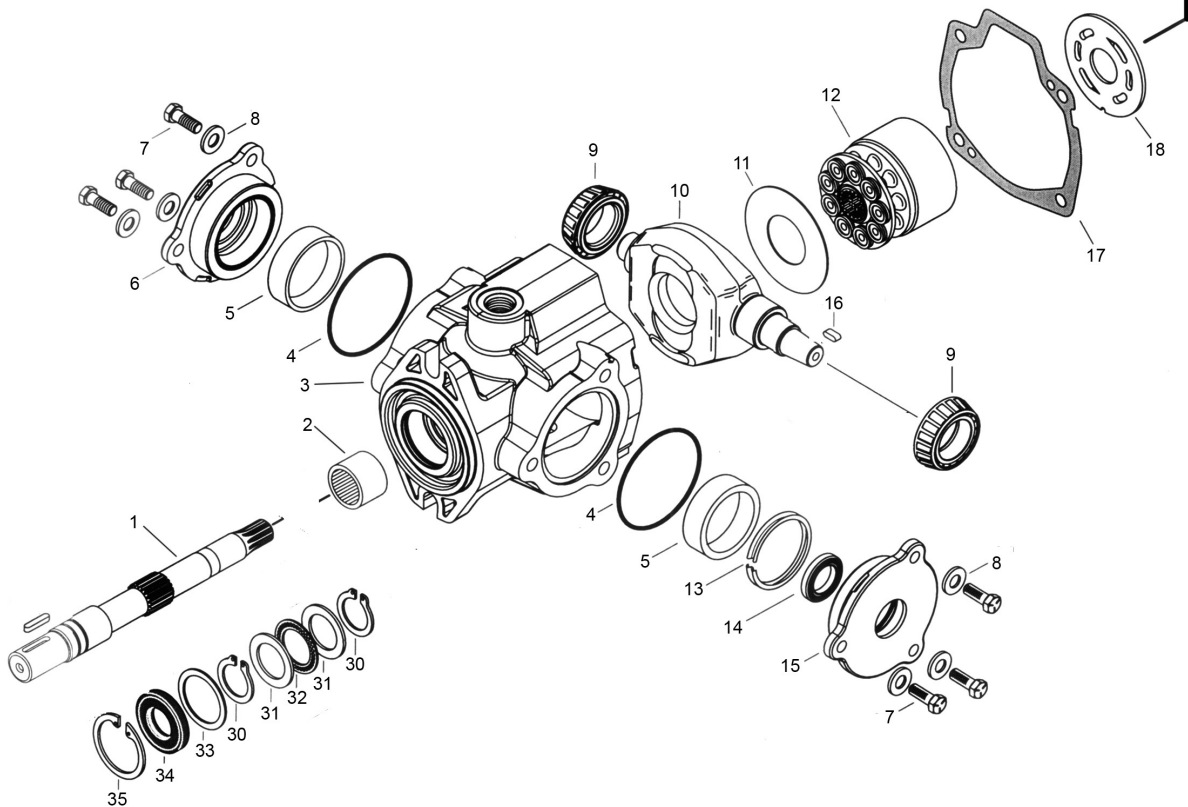
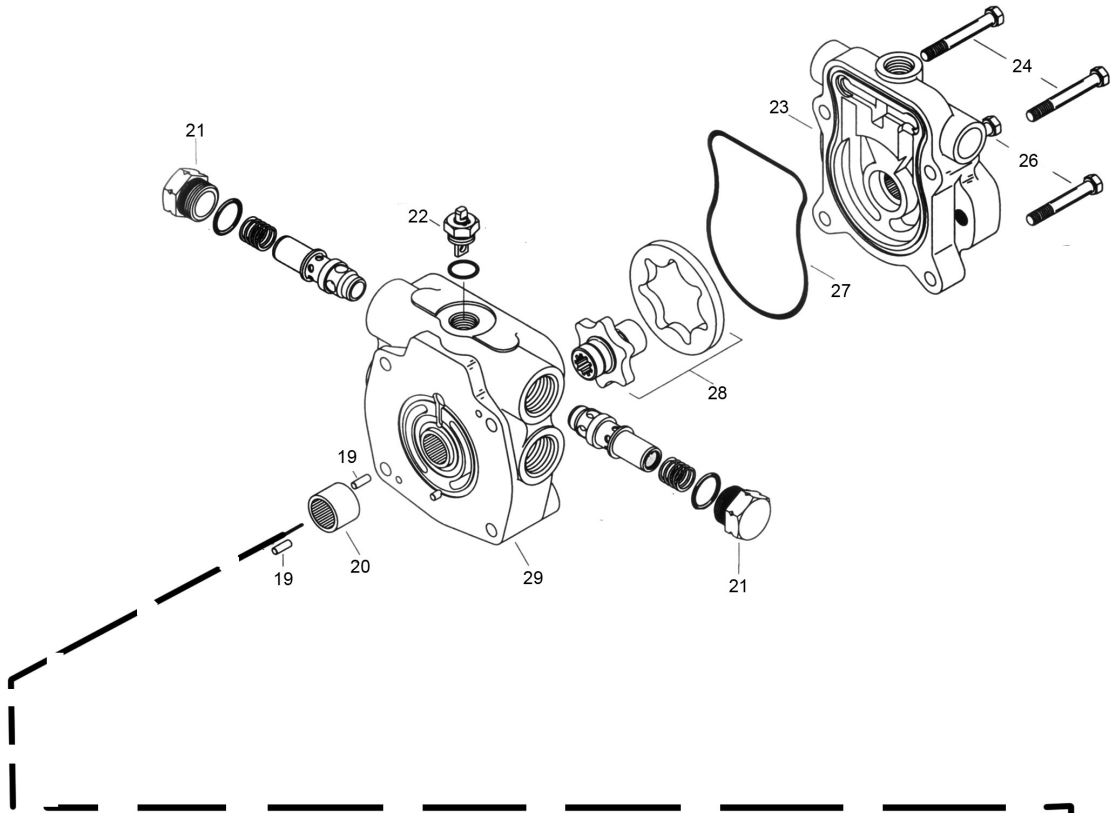

Parts

76-482 EATON HYDROSTATIC PUMP PARTS LIST (GAS)

REF#	PART#	DESCRIPTION	QUANTITY
1	76-398-01	Drive Shaft (splined)	1
2	60-343-08	Needle Bearing (with housing)	1
3	77-239-01	Housing	1
4	77-239-02	O-Ring	1
5	77-239-03	Thrust Bearing	2
6	77-239-04	Trunnion Cover	1
7	77-239-05	Pan Head Screw	2
8	77-239-06	Washer	6
9	77-239-07	Cone Bearing	2
10	77-239-08	Cam Plate	1
11	77-239-09	Swash Plate Insert	1
12	60-343-21	Rotating Kit	1
13	77-239-10	Crush Ring	1
14*	60-343-12	Shaft Seal	1
15	77-239-11	Seal Cover	1
16	77-239-12	Key	1
17*	77-239-13	Gasket	1
18	76-482-01	Back Plate	1
19	33-058-27	Dowel Pin	2
20	60-343-23	Bearing	1
21	77-239-15	Relief Valve	2
22	77-239-16	Tow Valve Assembly	1
23	76-160	Charge Pump Adapter	1
24	77-239-17	Cap Screw	2
26	77-239-18	Cap Screw	2
27*	77-239-19	O-Ring	1
28	60-343-43	Gerotor and Coupler	1
29	77-239-20	End Cover Assembly	1
30*	77-239-21	Retaining Ring	2
31	60-343-05	Bearing Race	1
32	60-343-06	Thrust Bearing	1
33	60-343-03	Washer	2
34*	60-343-02	Shaft Seal	1
35*	60-343-01	Retaining Ring	1

* 77-239-22 Seal Kit

76-197 EATON GEAR PUMP DRAWING

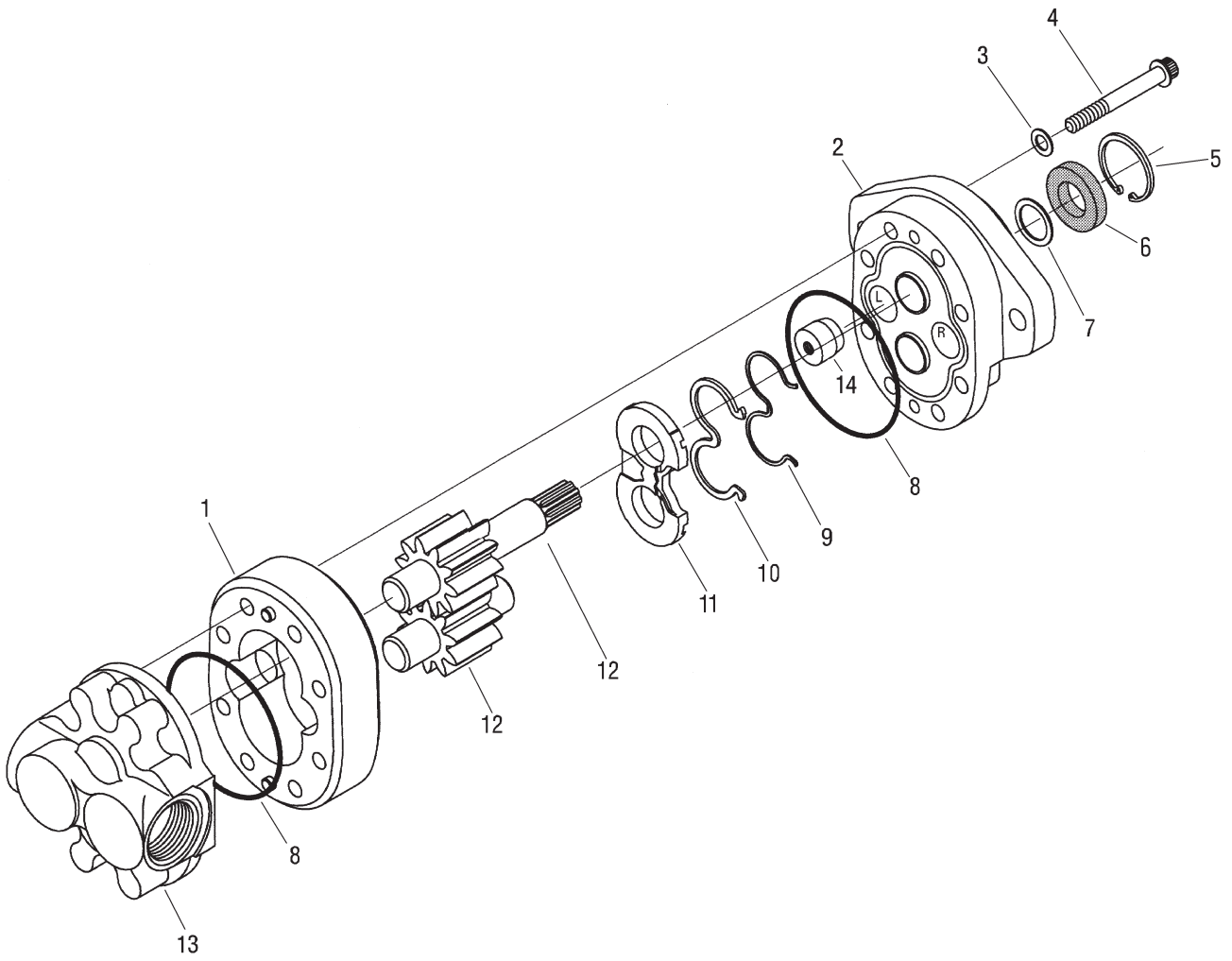

Parts

76-197 EATON GEAR PUMP PARTS LIST

REF#	PART#	DESCRIPTION	QUANTITY
1		Body	1
2	76-197-01	Front Plate	1
3*		Washer	4
4	76-197-06	Cap Screw	8
5	76-197-07	Retaining Ring	1
6*		Shaft Seal	1
7	33-061-15	Washer	1
8*		O-Ring	2
9*		Backup Gasket	1
10*		Seal	1
11*		Wear Plate	1
12	76-197-04	Shaft (comes with Idler Gear)	1
13	76-197-02	Back Plate	1
14*		Plug	1
*	76-197-08	Seal Kit	

76-238 REAR WHEEL MOTOR DRAWING (14.5 CI)

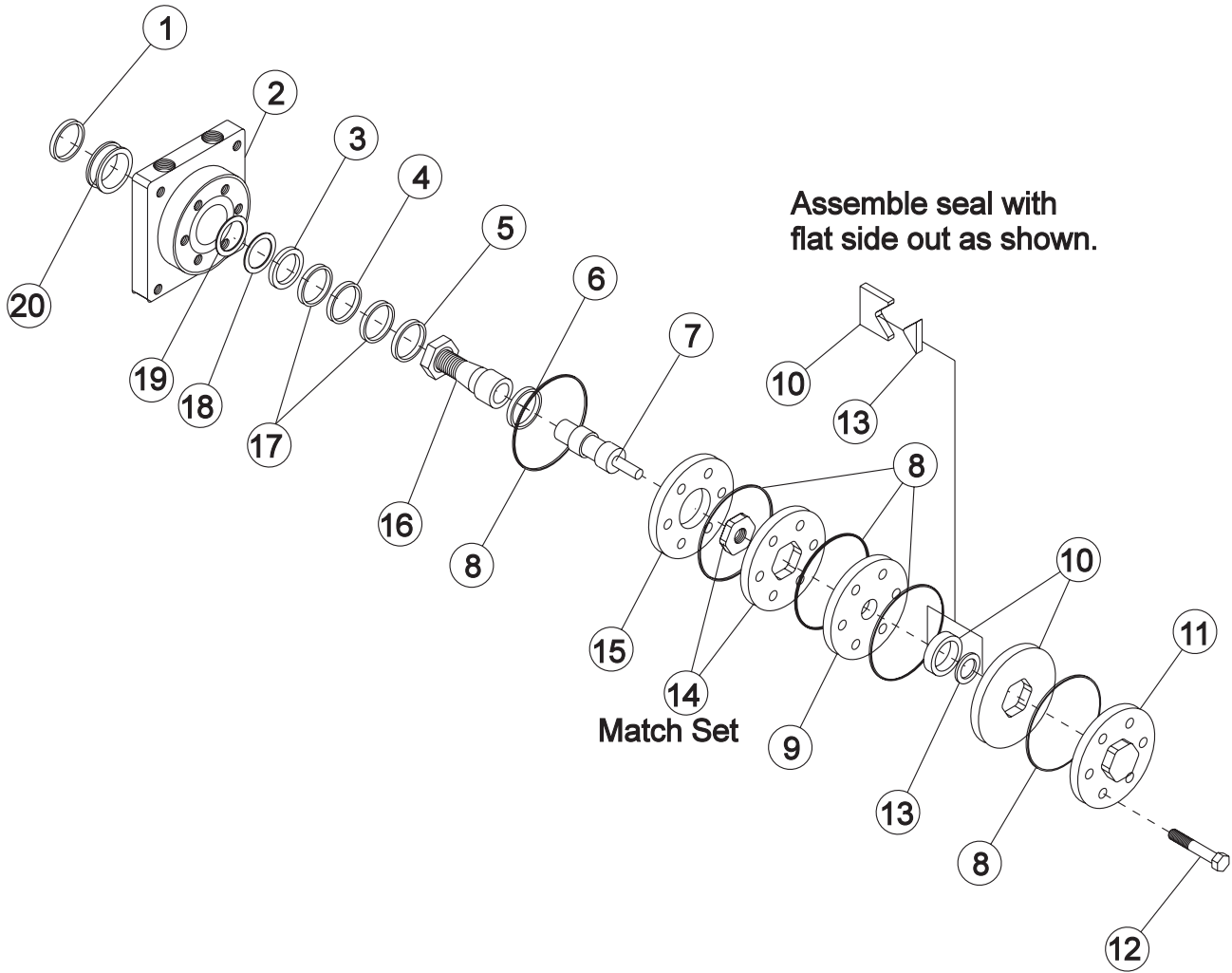

76-238 REAR WHEEL MOTOR PARTS LIST (14.5 CI)

REF#	PART#	DESCRIPTION	QUANTITY
1*		Water & Dirt Seal	1
2†	13-615-05	Service Housing Assembly	1
3*		Inner Seal	1
4†	13-032-27	Thrust Bearing	1
5†	13-032-28	Inner Bearing	1
6	13-032-29	Thrust Bearing	1
7	76-238-03	Drive Link	1
8*		Ring Seal	5
9	13-032-31	Manifold	1
10	13-032-32	Commutator Assembly (matched set)	1
11	13-032-33	End Cover	1
12	76-238-01	Hex Bolt	7
13*		Commutator Seal (matches with #10)	1
14	76-238-02	Rotor Set (matched set)	1
15	13-032-35	Plate Wear	1
16	13-615-04	Coupling Shaft	1
	HWK-516-100	Woodruff Key, $\frac{5}{16}$ x 1	1
	14-265	Nut, 1 - 20	1
17†	13-032-37	Thrust Washer	2
18*		Backup Washer	1
19*		Backup Washer	1
20†	13-032-38	Outer Bearing	1
*	14-080	Seal Kit	1
†	Included in 13-615-05 Service Housing Assembly		

76-023 3-BANK HYDRAULIC VALVE DRAWING

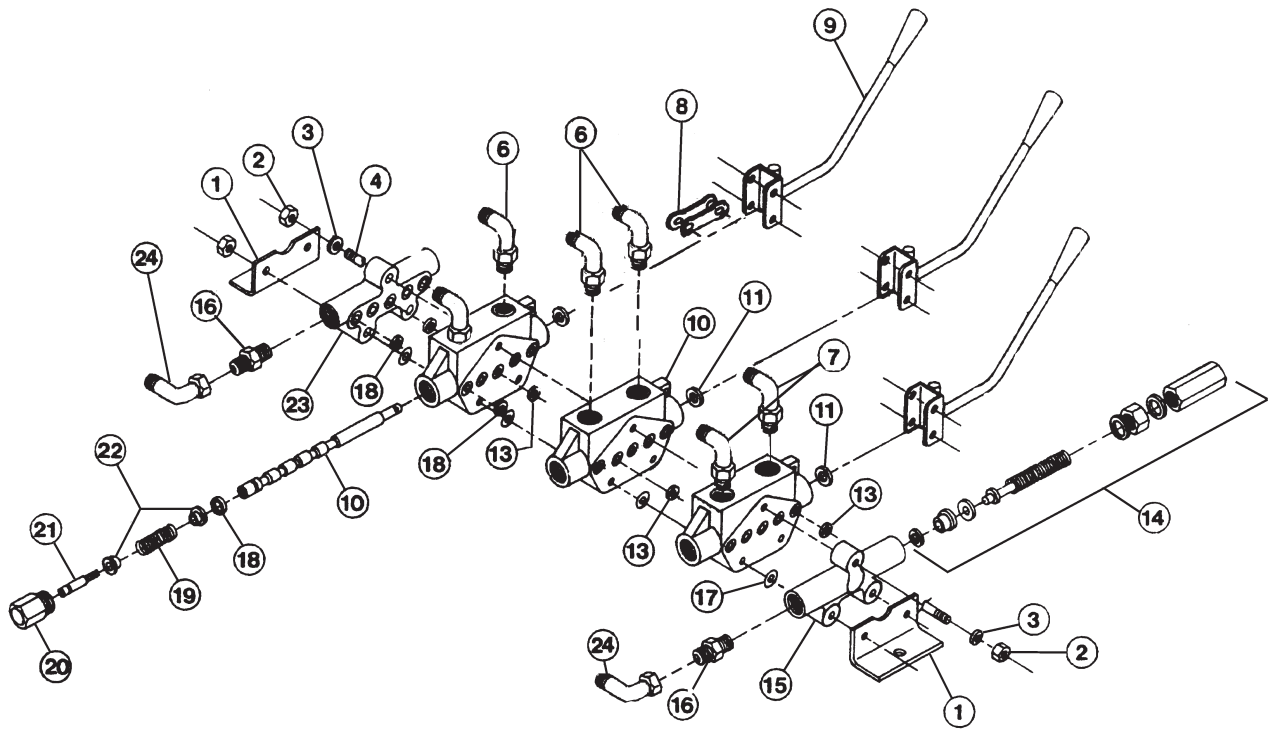

PARTS

76-023 3-BANK HYDRAULIC VALVE PARTS LIST

REF#	PART#	DESCRIPTION	QUANTITY
1	76-023-03	Mounting Bracket	2
2	HN-516-18	Hex Nut, ⁵ / ₁₆ - 18	6
3	HW-14	Flat Washer, ¹ / ₄	2
4	76-023-06	Tie Rod	3
6	18-188	Elbow 45°	4
7	18-168	Elbow 90°	2
8		Linkage (comes with handle)	
9	76-309	Valve Handle (sold as a set of 3)	1
	76-125-01	Knob	1 per handle
10	76-023-07	Body and Spool (matching set)	3
11*		In-body O-Ring	3
13*		O-Ring	15
14	76-023-08	Inlet Kit (load check and relief, 2000 psi)	1
15		Inlet with Load Check	1
16	18-169	Adapter	2
17*		Mylar Shim	9
18*		O-Ring	3
19		Spring (type 10 spool)	3
20	76-023-01	Spring Cap	3
21	76-023-02	Spring Shaft	3
22	76-023-09	Spring Guide	6
23	76-023-10	Outlet Open Center	1
24	18-214	Elbow 45°	2
*	14-096	O-Ring Seal Kit (includes all * items)	1

76-271 DUST/DIRT FILTRATION SYSTEM

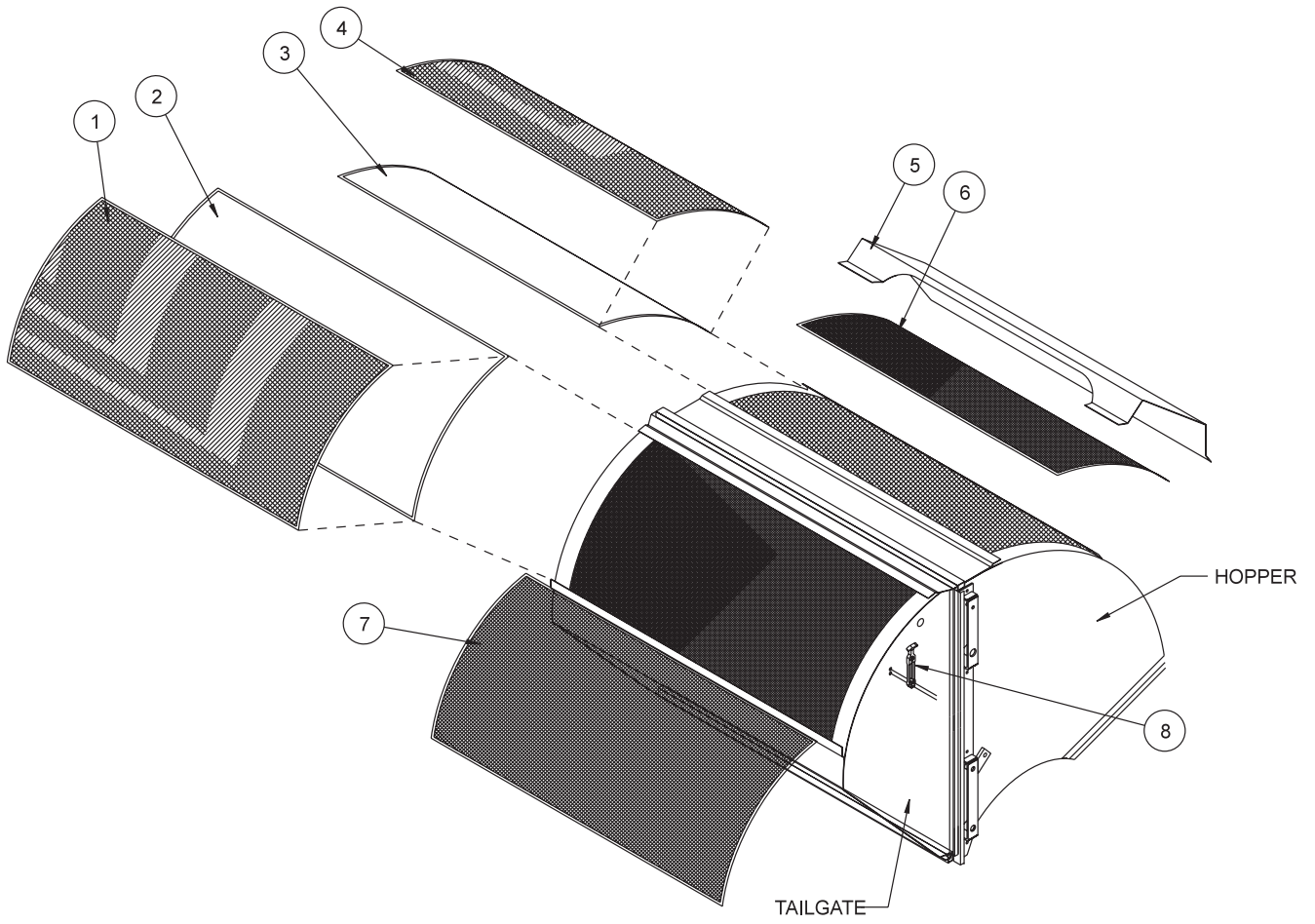

76-271 DUST/DIRT FILTRATION SYSTEM

REF#	PART#	DESCRIPTION	QUANTITY
1*	76-249	Tailgate Screen for Filter (28 x 58)	1
	*15-437-01	Keeper	2
	HRS-316-1125	Steel Rivet, $\frac{3}{16}$ x $1\frac{1}{8}$	2
2*	76-247	Tailgate Filter (28 x 57)	1
3*	76-246	Hopper Filter (24 x 57)	1
4*	76-248	Hopper Screen for Filter (24 x 28)	1
	*15-437-01	Keeper	2
5	76-263	Hopper Screen Cover (Serial Number 1000-1497)	1
	76-359	Hopper Screen Cover (Serial Number 1498 and Up)	1
6	76-261	Hopper Screen	1
7	76-262	Tailgate Screen	1
8	*15-437-02	Handle and Bracket	4
	HRS-316-1125	Steel Rivet, $\frac{3}{16}$ x $1\frac{1}{8}$	8
*	15-437	Latch (comes with 15-437-01 and 15-437-02)	2

INSTALLATION INSTRUCTIONS

1. If your sweeper has a latch (Ref 8) on the tailgate screen, release the latch.
2. There is enough rubber trim to place on each short ends of the hopper and tailgate screens. This will make a tighter seal. Do this before installing screens.
3. Remove tailgate screen (Ref 7) from tailgate. Unwedge the top and lift out of the bottom tab.
4. If your machine does not have the latch, please install it using the two steel $\frac{3}{16}$ x $1\frac{1}{8}$ rivets we provide.
5. First, place the cloth filter (Ref 2) onto the tailgate screen, then place tailgate filter screen (Ref 1) over the top of the cloth filter by placing the screen in to the bottom tab and wedging it into the top tab. The keeper part of the latch is already riveted onto the tailgate filter screen.
6. Place the handle and bracket onto the keeper and bend over the side of the tailgate to the desired tension, mark where the two holes from the handle and bracket line up on the tailgate side panel.
7. You need to drill two $\frac{3}{16}$ holes where your marks are, approximately centered on the curve and 1" from edge of material, on each tailgate side.
8. Release handle end from keeper and place bracket end of latch handle over holes you drilled, attach with two steel rivets.
9. Do this too both sides.
10. Remove the hopper screen cover (Ref 5) by unwedge the top and pulling it out of the bottom tab. You cannot use this cover with the filtration kit.
11. Remove the hopper screen (Ref 6) from the hopper by unwedge the top and pulling it out the bottom tab.
12. Place the cloth filter (Ref 3) onto the hopper, then place the hopper filter screen (Ref 4) over the top of the cloth filter by placing the screen in to the bottom tab and wedging it into the top tab.

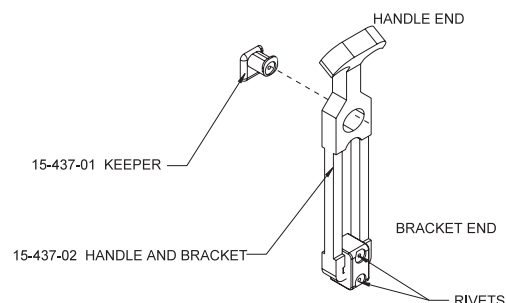

76-488 FRENCH BRUSH REEL KIT

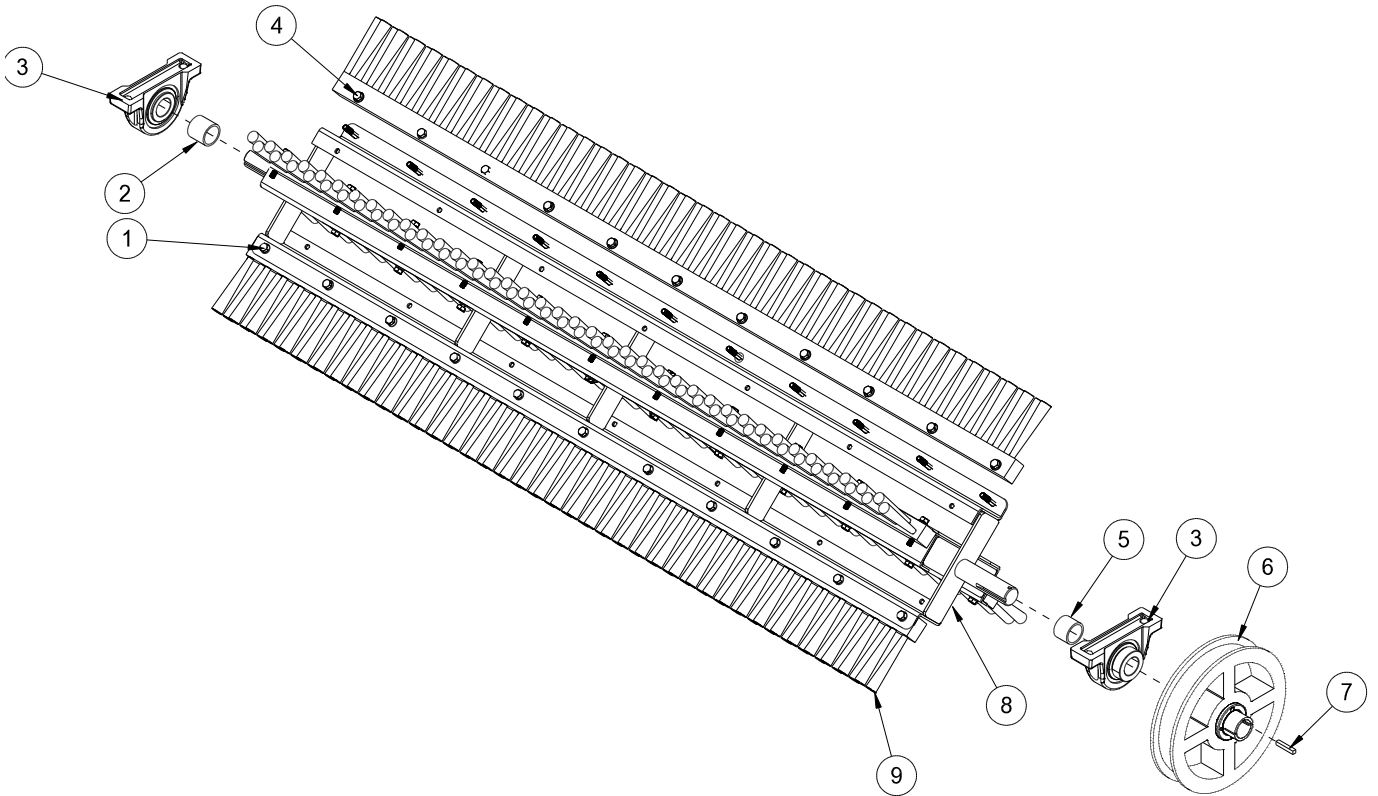

REF	PART#	DESCRIPTION	QUANTITY
1	HB-516-18-175	Bolt $\frac{5}{16}$ - 18 x $1\frac{3}{4}$	44
	HW-14	Washer $\frac{1}{4}$	44
2	75-686	Spacer	1
3	75-511	Pillow Block	2
4	HNTL-516-18	Lock Nut $\frac{5}{16}$ - 18	44
5	75-834	Spacer	1
6	76-102	Pulley with Hub	1
	76-102-01	Hub Only	
7	HKSQ-14-150	Square Key $\frac{1}{4}$ x $1\frac{1}{2}$	1
8	76-456	Brush Reel Frame	1
9	76-455	Brush	4

DECAL LIST

This is a list of decals located on the Sweep Star 60. Part number, description and location will help in reordering decals.

16-088*	Moving Parts Hot	Belt Guard
13-690	Diesel	Side Panel (diesel only)
25-078	Caution No Riders	Engine Cover
25-277*	Alternator/Battery	Under Seat on Hopper Panel
25-286	Pinch point	On Each Side Bottom Tailgate
25-307*	Gasoline	Console Back Above Fuel Tank (gas only)
25-313*	Slope 10° Max	Nose Cone
25-320*	Load Limit	Left Hopper Front
25-321	Diesel Fuel Only	Console Back Above Fuel Tank (diesel only)
25-352	By Pass valve	Hang Tag
25-355	Tire Pressure 18 psi	Rear Wheels
25-356	Tire Pressure 20 psi	Front Wheel and Castor Wheel
25-359	Smithco	Tailgate
25-362	Danger Fire	Hopper
25-376	98 dBA	Console
27-077	Round Smithco	Steering Wheel
27-093*	Hydraulic Oil Level	Console Back Above Hydraulic Tank
30-117	Ultra Fuel	Fuel Tank (diesel only)
34-147	Smithco Star	Front Nose Cone
75-651	Hopper Lift Safety	Hopper Lift Safety Bar
76-417	Sweep Star 60	One each Side of Hopper
76-199	Control Panel	Control Panel (gas only)
76-245	Reel Height	Right Tower on Front
76-304*	Crush/Pinch	Right and Left Hopper Front
76-305*	Rotating Parts	Right and Left Sides of Grass Chute
76-306*	Attachment Clutch	Engine Cover (diesel only)
76-307*	Tower Warning	Left and Right Towers
76-315*	Belt Routing	Behind Belt Guard
77-178	Control Panel	Control Panel (diesel only)
48-136	Decal, Sweeper Set (all * items)	
76-744	Decal Set CE	

QUICK REFERENCE REPLACEMENT PARTS

REPLACEMENT FILTERS

23-031	Hydraulic Oil Filter	
13-531	Engine Oil filter	Briggs # 842921
76-395-01	Air Cleaner Cartridge	Briggs # 841497
76-395-02	Safety Filter Cartridge	Briggs # 821136
50-403	Fuel Filter	

REPLACEMENT FILTERS KUBOTA ENGINE

17-255	Oil Filter Cartridge	
77-213	Air Cleaner Element (steel canister)	Kubota# 70000-11221
42-076-03	Air Cleaner Element (plastic canister)	
77-214	Fuel Filter Assembly	Kubota# 19204-43013
17-043	Fuel Filter Element	Kubota# 15231-4356-0

REPLACEMENT BELTS

76-200	Finger Reel Belt	2/A74
77-212	Kubota Fan Belt	Kubota# 15881-97011

SEAL KITS

76-023	3-Bank Hydraulic Valve
14-096	O-Ring Seal Kit
76-398	Hydrostatic Pump (Gas)
77-239	Hydrostatic Pump (Diesel)
77-239-22	Seal Kit
76-197	Gear Pump
76-197-08	Seal Kit
76-238	Wheel Motor
14-080	Seal Kit
76-242	Hydraulic Cylinder
76-242-01	Seal Kit
77-263	Hydraulic Cylinder
14-530	Seal Kit
76-478	Hydraulic Cylinder
14-531	Seal Kit

FLUIDS

Engine Oil Vanguard	SJ or Higher	10W-30
Engine Oil Kubota CC/ CD/ CE	10W-40	
Hydraulic Fluid	SJ or Higher	10W-40
Anti-Freeze	Use permanent type mixed with water. The anti-freeze mixing ratio must be less than 50%.	

OTHER PARTS

13-488	Key Switch	
17-068	Key Switch Kubota	
	Spark Plugs	Champion® type RC 12 YC or Equivalent Gap 0.030 (.76 mm) Torque 18/22 ft. lbs (24.4/29.8 Nm)
76-354	2 1/2 # ABC Dry Chemical Fire Extinguisher	
9023	Ceramic Heat Mat	

The Smithco Commercial Products Two-Year Limited Warranty

Smithco, Inc. (Smithco) warrants your 2016 or newer Smithco Commercial Product (“Product”) purchased after October 1, 2016 to be free from defects in materials or workmanship for the period of time listed below. Where a warrantable condition exists, Smithco will repair the Product at no cost to you including diagnosis, labor (at the Smithco standard labor rate, subject to the Smithco flat rate schedule), and parts.

Warranty Duration is:

- (1) Two years, 1500 operational hours* from the date of delivery to the original purchaser or Five years from the date of original manufacturer of the product, whichever occurs first. (*Products equipped with hour meter).
- (2) Products used in rental situations are covered for 90 days from date of delivery to original user/renter.

Owner Responsibilities:

As the Product owner, you are responsible for required maintenance and adjustments stated in your Owner’s Manual. Failure to perform required maintenance and adjustments can be grounds for disallowing a warranty claim. **You are particularly responsible to train all present and future operators of this product on the safe operation of this product at your location.**

Instructions for Obtaining Warranty Service:

You are responsible for notifying the Authorized Smithco Products Distributor from whom you purchased the Product as soon as you believe a warrantable condition exists and not later than 30 days from discovery of the condition.

If you need help locating an Authorized Smithco Distributor, or if you have questions regarding your warranty rights or responsibilities, you may contact us at:

Smithco Product Support Department
200 West Poplar Ave.
Cameron, Wisconsin 54822
Telephone: 800-891-9435 E-Mail: ProductSupport@Smithco.com

Maintenance Parts:

Parts scheduled for replacement as required maintenance (“Maintenance Parts”), are warranted for the period of time up to the scheduled replacement time for that part.

Items/Conditions Not Covered:

Not all product failures or malfunctions that occur during the warranty period are defects in materials or workmanship. The items/conditions listed below are not covered by this warranty:



Product failures which result from the use of non-Smithco replacement parts, or from installation and use of add-on, modified, or unapproved accessories are not covered.



Product failures which result from failure to perform required maintenance and/or adjustments are not covered.



Product failures that result from operating the Product in an abusive, negligent or reckless manner are not covered.



This warranty does not apply to parts subject to consumption through use, unless found to be defective. Examples of parts which are consumed, or used up, during normal Product operation include, but are not limited to: blades, tines, teeth, scarifiers, rakes, plates, wear plates, castor wheels, tires, batteries, filters, belts, nozzles, etc.



This warranty does not apply to failures caused by outside influence. Items considered to be outside influence include, but are not limited to, weather, storage practices, contamination, use of unapproved coolants, lubricants, additives, or chemicals, etc.



This warranty does not apply to normal “wear and tear” items. Normal “Wear and Tear” includes, but is not limited to, damage to seats due to wear or abrasion, worn painted surfaces, scratched decals or windows, etc.



Smithco may require the return of failed parts or components in order to determine the validity of any warranty claim.



Smithco will not be obligated to replace components of other manufacturers if inspection by the original component manufacturer indicates that failure was due to normal wear and tear, expected consumption through use or improper care or service.

Other Legal Disclaimers:

The above remedy for product defects through repair or replacement by an authorized Smithco distributor or dealer is the purchaser’s sole remedy for any defect. This warranty gives you specific legal rights, and you may also have other rights which vary from state to state.

THERE ARE NO OTHER EXPRESS WARRANTIES OTHER THAN THOSE SET FORTH ABOVE. ALL IMPLIED WARRANTIES OF MERCHANTABILITY AND FITNESS FOR USE ARE LIMITED TO THE DURATION OF THE LIMITED WARRANTIES CONTAINED HEREIN.

Some states may not allow limitations on how long an implied warranty lasts, so the above limitation may not apply to you.

THE SMITHCO COMPANY IS NOT LIABLE FOR INDIRECT, INCIDENTAL OR CONSEQUENTIAL DAMAGES IN CONNECTION WITH THE USE OF THE PRODUCT, INCLUDING ANY COST OR EXPENSE OF PROVIDING A SUBSTITUTE PRODUCT OR SERVICE DURING PERIODS OF MALFUNCTION OR NON-USE.

Some states may not allow the exclusion of indirect, incidental or consequential damages, so the above exclusion may not apply to you.

Smithco neither assumes, nor authorizes any person to assume for it, any other liability in connection with the sale or use of this product.

