



# **Diesel Spray Star 1200**

## **Truck Model 20-700-D**

**Manual System 1201D**  
**TeeJet Radion<sup>®</sup> 8140 1202D**  
**TeeJet<sup>®</sup> 744 1204D**  
**Matrix 908<sup>®</sup> 1215D/1218D/1220D**  
**TeeJet Radion/DynaJet<sup>®</sup> 1207D/1208D**

**SN: 200D503**

**Product Support:**

**Hwy 55 & Poplar Ave; Cameron WI 54822**

**1-800-891-9435    [productsupport@smithco.com](mailto:productsupport@smithco.com)**

# CONTENTS

## Introduction.....1-3

|                               |   |
|-------------------------------|---|
| Introduction.....             | 1 |
| General Safe Practices.....   | 2 |
| Specifications .....          | 3 |
| Optional Spray Equipment..... | 3 |

## Service.....4-9

|                               |     |
|-------------------------------|-----|
| Maintenance.....              | 4-6 |
| Storage.....                  | 6   |
| Service Chart.....            | 7   |
| End User's Service Chart..... | 8   |
| Adjustments.....              | 9   |

## Diagrams .....10-13

|                        |       |
|------------------------|-------|
| Wiring Diagram.....    | 10-11 |
| Hydraulic Diagram..... | 12-13 |

## Parts.....14-48

|                                  |       |
|----------------------------------|-------|
| Body & Frame .....               | 14-15 |
| Engine Cover/ Roll Bat .....     | 16-17 |
| Control Panel and Steering ..... | 18-19 |
| Foot Pedal Linkage.....          | 20-21 |
| Front Axle .....                 | 22-23 |
| Oil Tank and Fuel Tank .....     | 24-25 |
| Seat Panel.....                  | 26-27 |
| Hydraulic Pump.....              | 28-29 |
| Engine and Exhaust .....         | 30-31 |
| Spray Pump.....                  | 32-33 |
| Spray Tank.....                  | 34-35 |
| Turbo Quad Agitator .....        | 36-37 |
| Park Brake and Rear Axle .....   | 38-39 |
| 15-301 Orbital .....             | 40-41 |
| 76-638 Hydrostatic Pump.....     | 42-43 |
| 76-197 Eaton Gear Pump.....      | 44    |
| 76-238 Wheel Motor.....          | 45    |
| 15-970 Hypro® Pump .....         | 46-47 |
| 20-684 Flow meter.....           | 48    |

## Spray Systems.....50-96

|   |       |
|---|-------|
| Plumbing 1201 Manual System.....            | 50-51 |
| Plumbing 1202 System (Radion® 8140) .....   | 52-53 |
| Plumbing 1204 System (TeeJet® 744) .....    | 54-55 |
| 1202 Wiring System(Radion® 8140) .....      | 56    |
| 1204 Wiring System (TeeJet® 744) .....      | 57    |
| Control Mounts .....                        | 58-59 |
| Plumbing 1207/1208/1215/1218/1220 .....     | 60-61 |
| 1207/1208 DynaJet Wiring .....              | 62    |
| 1207/1208 Rear Module Mounts .....          | 63    |
| 1215/1218/1220 MATRIX Wiring .....          | 64    |
| 1215/1218/1220 DynaJet Wiring .....         | 65    |
| 1215/1218/1220 Rear Module Mounts .....     | 66    |
| 14-801/14-607 Strainer.....                 | 67    |
| 15-737/14-628 Flanged Strainer.....         | 68    |
| 15-743 Manifold Ball Valve .....            | 69    |
| 20-817 Regulaotr Valve .....                | 70    |
| 20-785 Regulator Valve .....                | 71    |
| 17-580 20' HD Boom .....                    | 72-75 |
| 17-580 20' HD Boom 1202/1204 Plumbing ..... | 76    |
| 17-580 20' HD Boom 1207 Plumbing .....      | 77    |
| 17-580 20' HD Boom 1220 Plumbing .....      | 78    |
| 17-585 18' HD Boom 1218 Plumbing .....      | 79    |
| 17-585 18' HD Boom .....                    | 80-83 |
| 17-585 18' HD 1202/1204 Plumbing .....      | 84    |
| 17-585 18' HD Boom 1208 Plumbing .....      | 85    |
| 17-601 15' HD Boom .....                    | 86-89 |
| 17-601 15' HD Boom 1202/1204 Plumbing ..... | 90    |
| 17-601 15' HD Boom 1215 Plumbing .....      | 91    |
| Boom Hinge.....                             | 92    |
| Standard Nozzle Assembly.....               | 93    |
| 1207/1208 Nozzle Assembly .....             | 94-95 |
| 1215/1218/1220 Nozzle Assembly .....        | 96    |

## Accessories .....97-122

|  |         |
|--|---------|
| 15-835 Tank Rinsing System.....            | 97      |
| 16-906 Electric Hose Reel .....            | 98-99   |
| Electric Hose Reel Wiring Diagram .....    | 100     |
| Hose Reel Adjustments .....                | 101     |
| 16-129 Manual Hose Reel .....              | 102     |
| 15-967 Hose Reel for HD Booms .....        | 103     |
| Hose Reel Plumbing.....                    | 104-105 |
| 15-965 Foam Marker Installation.....       | 106-109 |
| 14-291 Foam Marker Parts List.....         | 110-111 |
| Foam Marker Wiring .....                   | 112     |
| 20-815 Water Meter Kit .....               | 113     |
| 15-968 20 Gallon Rinse Tank .....          | 114-115 |
| 30-006 Fresh Water Tank - Rear Mount.....  | 116     |
| 10-653 Fresh Water Tank - Front Mount..... | 117     |
| 15-619 Chemical Clean-load System.....     | 118-122 |

## Reference .....123-124

|   |     |
|---|-----|
| Decal List.....                         | 123 |
| Quick Reference Replacement Parts ..... | 124 |
| Limited Warranty                        |     |

Thank you for purchasing a **Smithco** product.

Read this manual and all other manuals pertaining to the Spray Star 1200 diesel carefully as they have safety, operating, assembly and maintenance instructions. Failure to do so could result in personal injury or equipment damage.

Keep manuals in a safe place after operator and maintenance personnel have read them. Right and left sides are from the operator's seat, facing forward.

 **WARNING:**

**Engine exhaust and some of its constituents are known to the State of California to cause cancer, birth defects, and other reproductive harm.**  
For more information visit  
[www.P65Warning.ca.gov](http://www.P65Warning.ca.gov)

**WARNING**

*Failure to follow cautious operating practices can result in serious injury to the operator or other persons. The owner must understand these instructions, and must allow only trained persons who understand these instructions to operate this vehicle.*

All **Smithco** machines have a Serial Number and Model Number. Both numbers are needed when ordering parts. The serial number plate on the Spray Star 1200 diesel is located on right mainframe behind exhaust. Refer to engine manual for placement of engine serial number.

For product and accessory information, help finding a dealer, or to register your product please contact us at [www.Smithco.com](http://www.Smithco.com).

Information needed when ordering replacement parts:

1. Model Number of machine
2. Serial Number of machine
3. Name and Part Number of part
4. Quantity of parts

For easy access record your Serial and Model numbers here.

Model Number: \_\_\_\_\_

Serial Number: \_\_\_\_\_

Date of Purchase: \_\_\_\_\_

**SMITHCO CUSTOMER SERVICE 1-800-891-9435**

## SAFE PRACTICES

1. It is your responsibility to read this manual and all publications associated with this machine.
2. Never allow anyone to operate or service the machine or its optional equipment without proper training and instructions. Never allow minors to operate any equipment.
3. Learn the proper use of the machine, the location and purpose of all the controls and gauges before you operate the equipment. Working with unfamiliar equipment can lead to accidents.
4. Wear all the necessary protective clothing and personal safety devices to protect your head, eyes, ears, hands and feet. Operate the machine only in daylight or in good artificial light.
5. Inspect the area where the equipment will be used. Pick up all debris you can find before operating. Beware of overhead obstructions and underground obstacles. Stay alert for hidden hazards.
6. Never operate equipment that is not in perfect working order or without decals, guards, shields, or other protective devices in place.
7. Never disconnect or bypass any switch.
8. Carbon monoxide in the exhaust fumes can be fatal when inhaled, never operate a machine without proper ventilation.
9. Fuel is highly flammable, handle with care.
10. Keep engine clean. Allow the engine to cool before storing and always remove the ignition key.
11. Disengage all drives and set park brake before starting the engine.
12. Never use your hands to search for oil leaks. Hydraulic fluid under pressure can penetrate the skin and cause serious injury.
13. This machine demands your attention. To prevent loss of control or tipping of the vehicle:
  - A. Use extra caution in backing up the vehicle. Ensure area is clear.
  - B. Do not stop or start suddenly on any slope.
  - C. Reduce speed on slopes and in sharp turns. Use caution when changing directions on slopes.
  - D. Stay alert for holes in the terrain and other hidden hazards.
14. Before leaving operator's position:
  - A. Disengage all drives.
  - B. Set park brake.
  - C. Shut engine off and remove the ignition key.
  - D. If engine has to run to perform any maintenance keep hands, feet, clothing and all other parts of body away from moving parts.
15. Keep hands, feet and clothing away from moving parts. Wait for all movement to stop before you clean, adjust or service the machine.
16. Keep the area of operation clear of all bystanders.
17. Never carry passengers.
18. Stop engine before making repairs/adjustments or checking/adding oil to the crankcase.
19. Use parts and materials supplied by **Smithco** only. Do not modify any function or part.
20. Use caution when booms are down as they extend out beyond the center line of the machine.
21. The tank is a confined space, take precaution.

***These machines are intended for professional maintenance on golf courses, sports turf, and any other area maintained turf and related trails, paths and lots. No guaranty as to the suitability for any task is expressed or implied.***

# SPECIFICATIONS SPRAY STAR 1200 DIESEL

## WEIGHTS AND DIMENSIONS

|                            |                    |
|----------------------------|--------------------|
| Length                     | 127" (323 cm)      |
| Width                      | 65" (165 cm)       |
| Width With 18' Boom Open   | 240" (610 cm)      |
| Height w/ Roll Bar         | 78" (195 cm)       |
| Height w/ 18' Booms Folded | 110" (279 cm)      |
| Wheel Base                 | 68" (173 cm)       |
| Weight Empty               | 1947 lbs (883 kg)  |
| Weight Full                | 3698 lbs (1677 kg) |

## SOUND LEVEL (DBA)

|                    |        |
|--------------------|--------|
| At ear level       | 89 dBA |
| At 3 ft. (0.914 m) | 88 dBA |
| At 30 ft. (9.14 m) | 79 dBA |

## ENGINE

|                    |  |
|--------------------|--|
| Kubota             |  |
| Model#             | D1105-E3B  |
| Horsepower         | 25 hp (18.5 kW)  |
| Fuel               | No.1-D or No. 2-D, S500: Low Sulfur Diesel (LSD) less than 500 ppm or 0.05 wt.%<br>No.1-D or No.2-D, S15: Ultra Low Sulfur Diesel (ULSD) less than 15 ppm or 0.0015 wt.% |
| Cooling System     | Liquid Cooled  |
| Lubrication System | Full Pressure  |
| Alternator         | 15 Amp   |

## WHEELS & TIRE

Front: Two 20 x 10.00 x 10 NHS Multi-Rib; 20 psi (1.4 bar)  
Rear: Two 24 x 13.00 x 12 NHS Multi-Trac; 20 psi (1.4 bar)

## SPEED

Infinitely Variable 0-10 m.p.h. (0-16 kph)

## BATTERY

|                          |                               |
|--------------------------|-------------------------------|
|                          | Automotive type 24F - 12 volt |
| BCI Group                | Size 24                       |
| Cold Cranking Amps       | 900 minimum                   |
| Ground Terminal Polarity | Negative (-)                  |
| Maximum Length           | 10.25" (26 cm)                |
| Maximum Width            | 6.88" (17 cm)                 |
| Maximum Height           | 10" (25 cm)                   |

## FLUID CAPACITY

|                          |   |
|--------------------------|---|
| Crankcase Oil            | See Engine Manual                             |
| Fuel                     | 10 gallon (45.46 liters)                      |
| Hydraulic Fluid          | 5 gallon (19 liters)                          |
| Grade of Hydraulic Fluid | SAE 10W-40 API Service SJ or higher Motor Oil |

## OPTIONAL EQUIPMENT

|        |   |        |  |
|--------|---|--------|--|
| 20-815 | Water Meter Kit                                       | 15-835 | Tank Rinsing System                    |
| 15-619 | Chemical Clean-load                                   | 10-653 | Fresh Water Wash Tank- Front Mount     |
| 15-622 | Canopy  | 30-006 | Fresh Water Wash Tank - Rear Mount     |
| 15-965 | Foam Marker   | 15-968 | 26 Gal. Wash System with Electric Pump |
| 17-601 | 15' HD Boom   | 17-585 | 18' HD Boom                            |
| 15-967 | Hose Reel Mount Kit                                   | 17-580 | 20' HD Boom                            |
| 16-129 | Manual Rewind Hose Reel, 200-foot/61-meter capacity   |        |  |
| 16-906 | Electric Rewind Hose Reel, 200-foot/61-meter capacity |        |  |



# MAINTENANCE

## ⚠ CAUTION

Before servicing or making adjustments to machine, stop engine and remove key from ignition.

## ⚠ IMPORTANT

Use all procedures and parts prescribed by the manufacturer's. Read the engine manual before operation.

### LUBRICATION

Use No. 2 General purpose lithium base grease and lubricate every 100 hours. The Spray Star 1200 diesel has 7 lube points.

- A. One on the rod end of hydraulic cylinder.
- B. One on each the right and left spindles.
- C. One on the reverse pedal.
- D. One on each end of tie rod.
- E. One on the forward pedal.

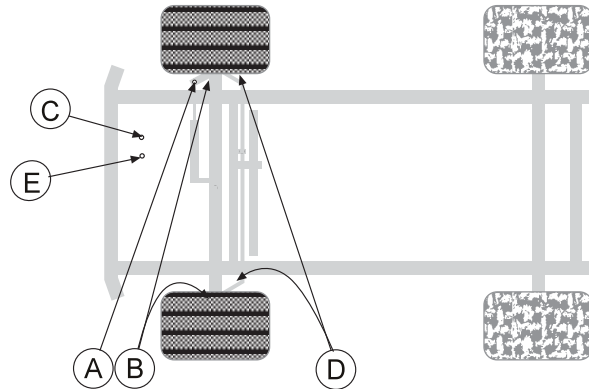

### ELECTRICAL CONNECTIONS

Use dielectric grease on all electrical connections.

### TIRE PRESSURE

Caution must be used when inflating a low tire to recommended pressure. Over inflating can cause tires to explode. All tires should be 20 psi (1.4bar). Improper inflation will reduce tire life considerably.

### WHEEL MOUNTING PROCEDURE

1. Set park brake. Turn machine off and remove key.
2. Block wheel on opposite corner.
3. Loosen nuts slightly on wheel to be removed.
4. Jack up machine being careful not to damage underside of machine.
5. Place wheel on hub lining up bolt holes.
6. Torque to 64-74 ft/lb (87-100Nm) using a cross pattern. Re-torque after first 10 hours and every 200 hours thereafter.
7. Lower machine to ground and remove blocks and jack.

## ENGINE OIL

With strict emission control regulations now in effect, the CF-4 and CG-4 engine oils have been developed for use with low sulfur fuels, for On-Highway vehicle engines. When Non-Road engines run on high sulfur fuel, it is advisable to use a "CF or better" classification engine oil with Total Base Number (a minimum TBN of 10 is recommended).

Check the engine oil before starting or more than 5 minutes after stopping the engine. If oil level is low, remove oil filler plug and add new oil to the prescribed level. Do not overfill. Engine oil should be MIL-L2104C or have properties of API Classifications CD grades or higher. Change the type of Engine oil according to the ambient temperature.

| O= Recommended        | X= Not Recommended |   |
|-----------------------|--------------------|---|
| Lubricating Oil Class | Fuel               |   |
| CF-4                  | O                  | X |
| CG-4                  | O                  | X |

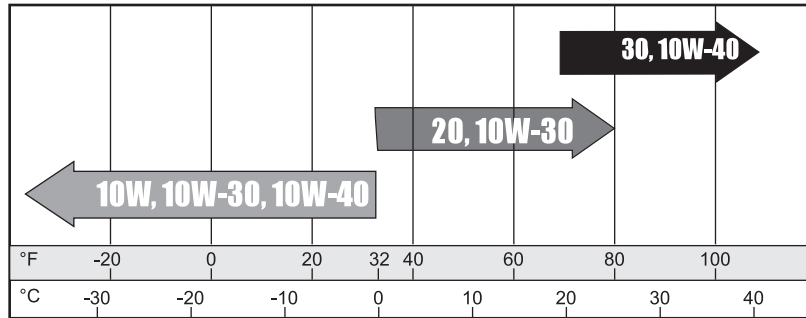

*Starting Temperature Range Anticipated Before Next Oil Change*

## HYDRAULIC OIL

1. Use SAE 10W-40 API Service SJ or higher motor oil.
2. For proper warranty, change oil the first 50 hours and then every 500 hours or annually, whichever is first.
3. Oil level should be 2-2½" (5-6.4cm) from top of the tank when fluid is cold. Do not overfill.
4. After changing oil, run the machine for a few minutes. Check oil level and for leaks.
5. Always use extreme caution when filling hydraulic oil tank or checking level to keep system free of contaminants. Check and service more frequently when operating in extremely cold, hot or dusty conditions.
6. If the natural color of the fluid has become black or smells burnt, it is possible that an overheating problem exists.
7. If fluid becomes milky, water contamination may be a problem.
8. If either of the above conditions happen, change oil immediately after fluid is cool and find the cause. Take fluid level readings when the system is cold.
9. In extreme temperatures you can use straight weight oil. We recommend SAE 30W API Service SG when hot (above 90°F (33°C)) and SAE 10W API Service SJ or higher when cold (below 32°F (0°C) ambient temperature. Use either motor oil or hydraulic oil, but do not mix.
10. Oil being added to the system must be the same as what is already in the tank. Mark the tank fill area as to which type you put in.

# MAINTENANCE

## BATTERY

Batteries normally produce explosive gases which can cause personal injury. Do not allow flames, sparks or any ignited object to come near the battery. When charging or working near battery, always shield your eyes and always provide proper ventilation.

Battery cable should be disconnected before using "Fast Charge."

Charge battery at 15 amps for 10 minutes or 7 amps for 30 minutes. Do not exceed the recommended charging rate. If electrolyte starts boiling over, decrease charging.

Always remove grounded (-) battery clamp first and replace it last. Avoid hazards by:

1. Filling batteries in well-ventilated areas.
2. Wear eye protection and rubber gloves.
3. Avoid breathing fumes when electrolyte is added.
4. Avoid spilling or dripping electrolyte.

### ⚠ WARNING

**Battery Electrolyte is an acidic solution and should be handled with care. If electrolyte is splashed on any part of your body, flush all contact areas immediately with liberal amounts of water. Get medical attention immediately.**

### ⚠ WARNING

**Use of booster battery and jumper cables. Particular care should be used when connecting a booster battery. Use proper polarity in order to prevent sparks.**

### TO JUMP START (NEGATIVE GROUNDED BATTERY):

1. Shield eyes.
2. Connect ends of one cable to positive (+) terminals of each battery, first (A) then (B).
3. Connect one end of other cable to negative (-) terminal of "good" battery (C).
4. Connect other end of cable (D) to engine block on unit being started (NOT to negative (-) terminal of battery)

To prevent damage to other electrical components on unit being started, make certain that engine is at idle speed before disconnecting jumper cables.

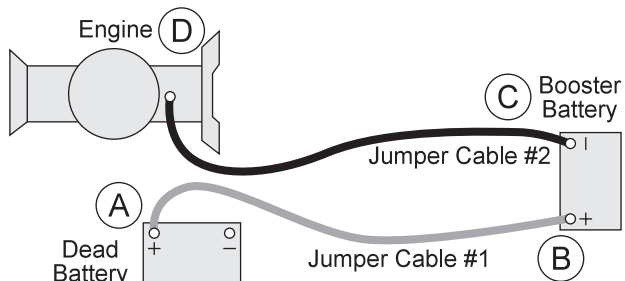

# STORAGE

If the engine will be out of service for two or more months, use the following storage procedure.

1. Clean the exterior surfaces of the engine.
2. Change the oil and filter while the engine is still warm from operation.
3. The fuel system must be completely emptied, or the gasoline must be treated with a stabilizer to prevent deterioration.

If you choose to use a stabilizer, follow manufacturers recommendations, and add the correct amount for the capacity of fuel system. Fill fuel tank with clean, fresh gasoline. Run engine for 2-3 minutes to get stabilized fuel into carburetor. Close fuel shut-off valve when unit is being stored or transported.

To empty the system, drain fuel tank and carburetor, or run engine until tank and system are empty.

4. Remove the spark plugs. Add one tablespoon of engine oil into each spark plug hole. Install plugs, but do not connect the plug leads. Crank the engine two or three revolutions.
5. Store machine in a clean, dry place.



# SERVICE CHART

| Item                              | Maintenance Procedure   |
|-----------------------------------|---|
| After the first 8 operating hours | Torque the wheel lug nuts. (64-74 ft/lb (87-100 Nm))<br>Change the engine oil filter.   |
| Before each use daily             | Check the engine oil level.<br>Clean area around muffler and controls.<br>Check the hydraulic fluid level.<br>Check the tire pressure.<br>Check condition of hydraulic hoses and fittings.<br>Check for oil or water leaks.<br>Proper function of glow lamp timer.                      |
| After the first 50 hours          | Change Hydraulic Oil Filter.<br>Change Engine oil and filter.   |
| Every 100 hours                   | Clean or change air filter. <sup>1&amp;2</sup><br>Clean fuel filter element. <sup>1</sup><br>Lubricate machine.<br>Check the battery fluid level and cable connections..<br>Check fan belt tension and damage.  |
| Every 200 hours                   | Check radiator hoses and clamp bands.<br>Change engine oil. <sup>1</sup><br>Check idle speed.<br>Replace oil filter cartridge. <sup>1</sup><br>Change hydraulic oil filter. <sup>1</sup><br>Check air intake line. <sup>1</sup><br>Torque the wheel lug nuts. (64-74 ft/lb (87-100 Nm)) |
| Every 500 hours or yearly         | Clean Water Jacket and radiator interior.<br>Replace fan belt.  |
| Every 800 hours                   | Check valve clearance.  |
| Every 1500 hours                  | Check injection nozzle pressure.  |
| Every 3000 hours                  | Check turbo charger.<br>Check injection pump.<br>Check injection timing.  |
| Every 2 years                     | Change radiator coolant (L.L.C.)<br>Replace radiator hoses and clamp bands.<br>Replace fuel hoses and clamps.<br>Replace intake air lines.  |

<sup>1</sup> In dusty conditions or when airborne debris is present, clean more often.

<sup>2</sup> Replace after every 6 times of cleaning

# END USER SERVICE CHART

**⚠ CAUTION**

Before servicing or making adjustments to the machine, stop engine, block wheels and remove key from ignition.

**⚠ IMPORTANT**

Follow all procedures and **ONLY** use parts prescribed by the manufacturer. Read the engine manual before maintenance.

The suggested maintenance checklist is not offered as a replacement for the manufacturer's engine manual but as a supplement. You must adhere to the guidelines established by the manufacturer for warranty coverage. In adverse conditions such as dirt, mud or extreme temperatures, maintenance should be more frequent.

Service

**Duplicate this page for routine use.**

| Maintenance Check Item                        | For the week of: |       |      |        |      |      |      |
|---|------------------|-------|------|--------|------|------|------|
|   | Mon              | Tues. | Wed. | Thurs. | Fri. | Sat. | Sun. |
| Check the Safety Seat Switch                  |                  |       |      |        |      |      |      |
| Check Steering Operation                      |                  |       |      |        |      |      |      |
| Check the fuel level                          |                  |       |      |        |      |      |      |
| Check the engine oil level.                   |                  |       |      |        |      |      |      |
| Check the condition of the air filter         |                  |       |      |        |      |      |      |
| Clean the engine cooling fins.                |                  |       |      |        |      |      |      |
| Check for unusual engine noises               |                  |       |      |        |      |      |      |
| Check the hydraulic oil level                 |                  |       |      |        |      |      |      |
| Check hydraulic hoses and fittings for damage |                  |       |      |        |      |      |      |
| Check for fluid leaks.                        |                  |       |      |        |      |      |      |
| Check the tire pressure (20-30 psi)           |                  |       |      |        |      |      |      |
| Check the Instrumentation                     |                  |       |      |        |      |      |      |
| Inspect electrical system for frayed wires    |                  |       |      |        |      |      |      |
| Check neutral start                           |                  |       |      |        |      |      |      |
| Change oil filter.                            |                  |       |      |        |      |      |      |
| Change oil.                                   |                  |       |      |        |      |      |      |
| Lubricate Machine and Booms                   |                  |       |      |        |      |      |      |
| Ensure all warning decals are intact.         |                  |       |      |        |      |      |      |

| Areas of Concern         |      |             |
|--------------------------|------|-------------|
| Inspection Performed by: |      |             |
| Item                     | Date | Information |
|                          |      |             |
|                          |      |             |
|                          |      |             |
|                          |      |             |
|                          |      |             |
|                          |      |             |

## WHEEL CREEP

"Creep" is when the engine is running and hydrostatic transmission is in neutral, but due to inadequate alignment, wheels still move. Do the following procedure to stop this motion.

1. Lift up and support machine so rear wheels are off the ground and can turn freely.
2. In the engine compartment, the hydrostatic transmission is on the left side. The shift arm (D) is under the pump and comes out the side. The idler arm (B) has a bearing that runs in the notch of the shift arm. Loosen bolt (A).
3. With engine running, move bearing (B) so it centers on the shift arm (D) and 'wheel creep' stops.
4. Tighten all fasteners and test by using foot pedal linkage to see that 'creep' is removed.
5. Turn engine off and lower machine.

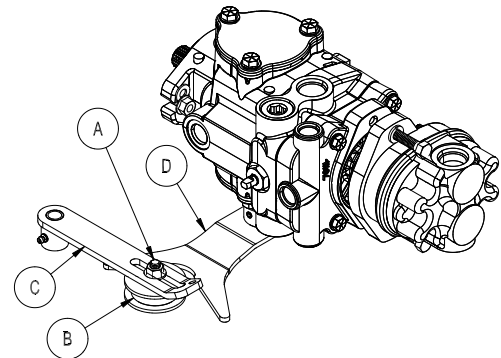

## SPRAY PUMP WITH BELT

Located below the engine. The belt should have approximately  $\frac{1}{2}$ " (13mm) of deflection in the center of the top strand. Loosen and tighten the  $\frac{5}{16}$ "-18 x  $1\frac{1}{4}$ " set screw located on the foot of the pump mount.

## PARK BRAKE

Turn knob clockwise on end of park brake to tighten. Turn it counter clockwise to loosen. If finer adjustment is needed turn clevis on brake cable to adjust length of cable.

## MASTER BOOM SWITCH (FOOT SWITCH)

The master boom switch, located on the left floorboard is used to override the master switch on the computer console of the spray systems. By pushing down it will turn on/off the booms.

## GROUND SPEED CONTROL (FOOT SWITCH)

The ground speed control does not work the same as an automotive type cruise. The ground speed control is located on the left floorboard and is used to lock forward speed.

## TO ENGAGE:

1. Flip rocker switch 'On' (green light).
2. Obtain desired speed with foot pedal.
3. Step on foot switch to lock speed.
4. Push foot switch again to disengage.

## SPRAY BOSS CONTROL - ORANGE

Engages and disengages speed boss. Forward is engage and all the way back is disengage. When the lever is engaged it sets a stop for the accelerator. The accelerator pedal must be used to maintain this speed. To adjust speed use the knob on the end of the lever, counter clockwise increases speed and clockwise decreases speed. Disengage the lever and you will have full accelerator pedal range.

# 20-870 MAIN WIRE HARNESS DIAGRAM

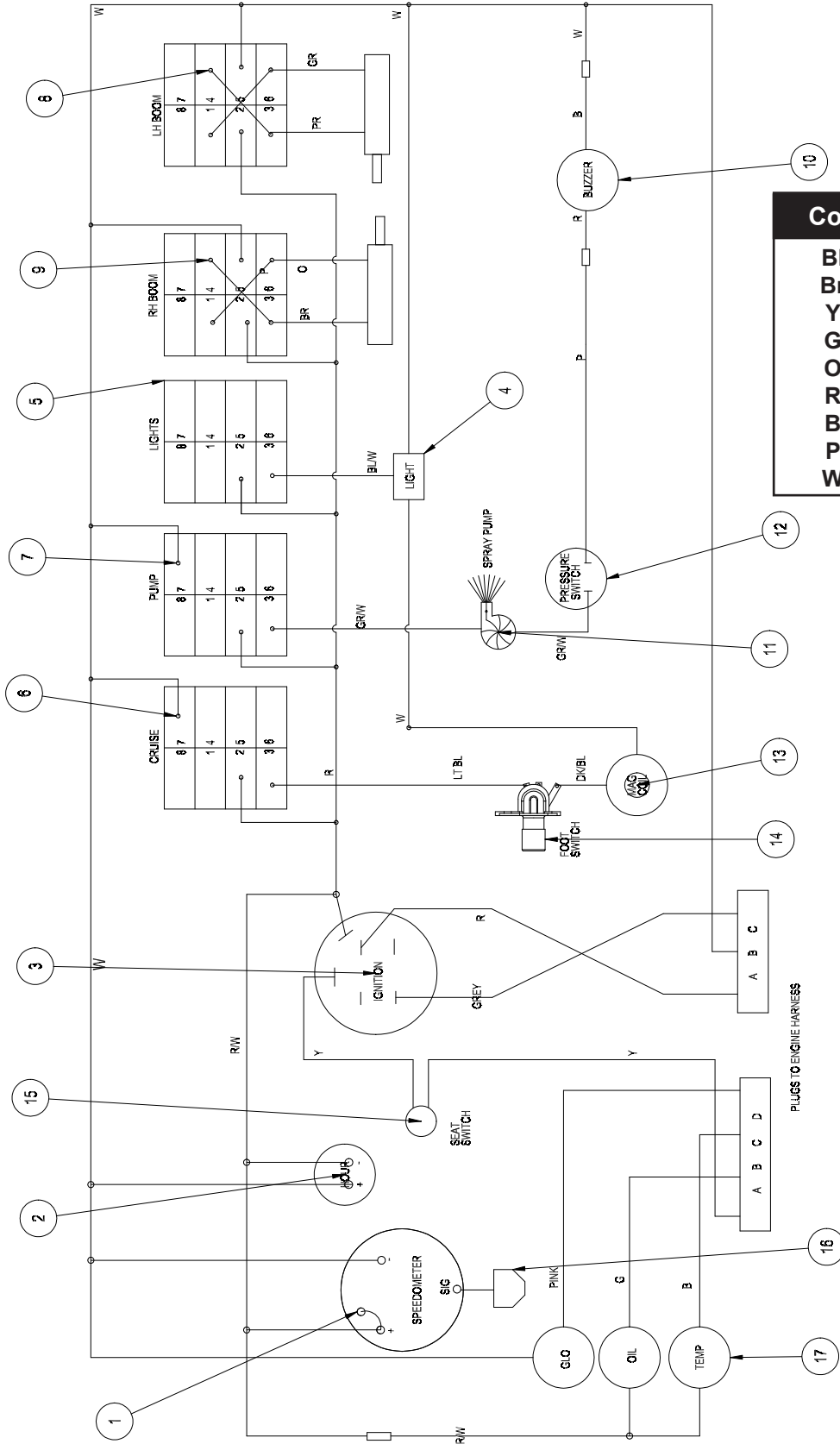

## Color Code Chart

|    |        |
|----|--------|
| Bl | Blue   |
| Br | Brown  |
| Y  | Yellow |
| G  | Green  |
| O  | Orange |
| R  | Red    |
| B  | Black  |
| P  | Purple |
| W  | White  |

## 20-870 MAIN WIRE HARNESS PARTS LIST

| REF# | PART#      | DESCRIPTION                            | QUANTITY |
|------|------------|--|----------|
| 1    | 30-356     | Speedometer                            | 1        |
| 2    | 12-804     | Hour Meter                             | 1        |
| 3    | 13-488     | Ignition Switch                        | 1        |
| 4    | 20-912     | Light                                  | 1        |
| 5    | Lights     |  |          |
|      | 15-725     | Mount Panel End                        | 1        |
|      | 15-782     | Non-Lighted Switch, On-None-Off        | 1        |
|      | 15-727     | Rocker - No light                      | 1        |
| 6    | Cruise     |  |          |
|      | 15-729     | Mount Panel Middle                     | 1        |
|      | 15-726     | Lighted Switch                         | 1        |
|      | 15-732     | Rocker , Green                         | 1        |
| 7    | Pump       |  |          |
|      | 15-729     | Mount Panel Middle                     | 1        |
|      | 15-726     | Lighted Switch                         | 1        |
|      | 15-731     | Rocker, Amber                          | 1        |
| 8    | Left Boom  |  |          |
|      | 15-729     | Mount Panel Middle                     | 1        |
|      | 15-728     | Centering Switch, Momentary, On-Off-On | 1        |
|      | 15-727     | Rocker - No light                      | 1        |
| 9    | Right Boom |  |          |
|      | 15-725     | Mount Panel End                        | 1        |
|      | 15-727     | Rocker - No light                      | 1        |
|      | 15-728     | Centering Switch, Momentary, On-Off-On | 1        |
| 10   | 77-207     | Buzzer                                 | 1        |
| 11   | 15-970     | Spray Pump                             | 1        |
| 12   | 33-480     | Pressure Switch                        | 1        |
| 13   | 33-084     | Magnetic Coil                          | 1        |
| 14   | 33-509     | Master Boom Switch                     | 1        |
| 15   | 14-292     | Seat Switch                            | 1        |
| 16   | 20-730-01  | Speedometer Antenna                    | 1        |
| 17   | 50-359     | Glo - Oil - Temperature Lights         | 3        |

# 20-869 ENGINE WIRE HARNESS DIAGRAM

Diagrams

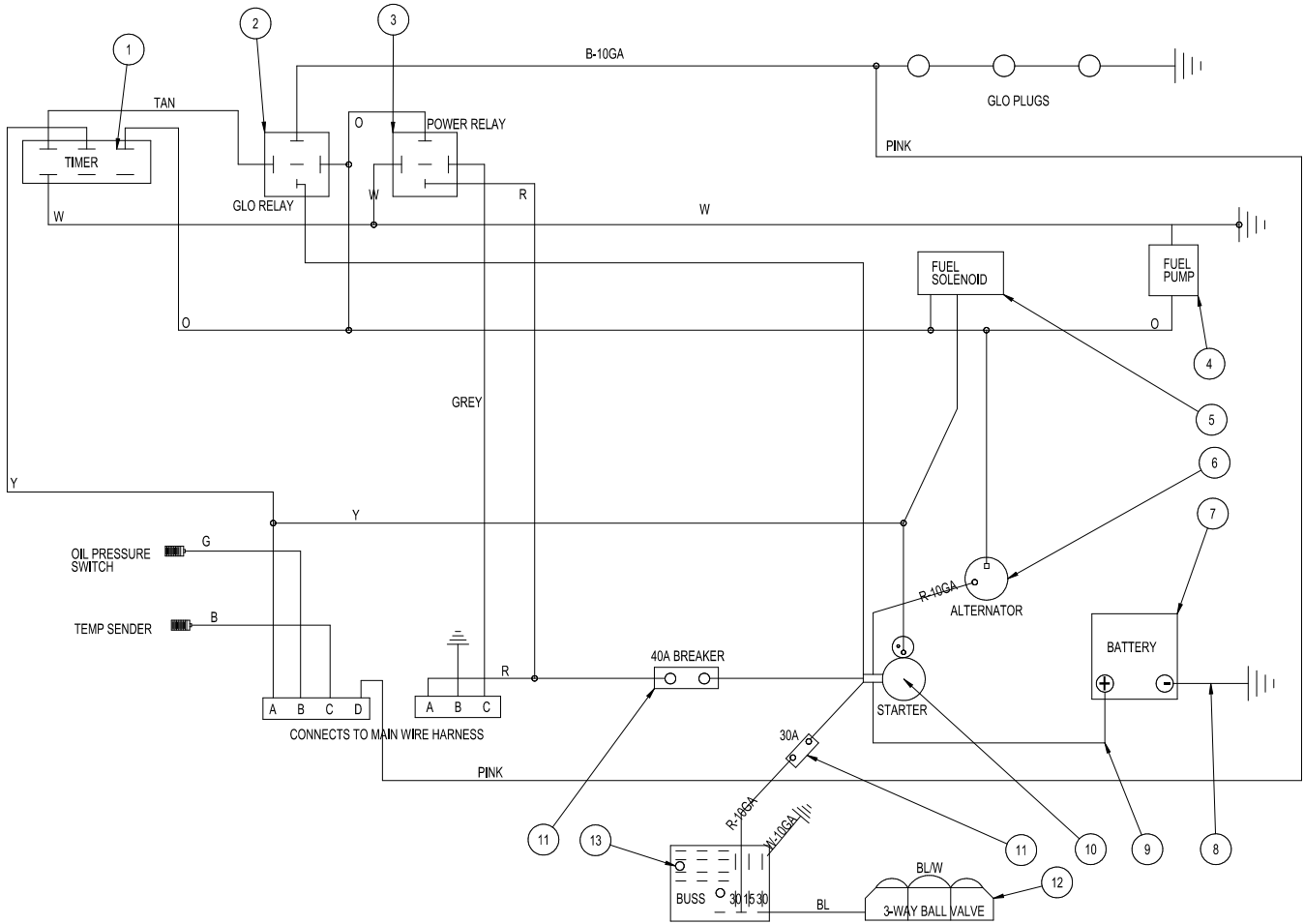

## Color Code Chart

|    |        |
|----|--------|
| Bl | Blue   |
| Br | Brown  |
| Y  | Yellow |
| G  | Green  |
| O  | Orange |
| R  | Red    |
| B  | Black  |
| P  | Purple |
| W  | White  |

## 20-869 ENGINE WIRE HARNESS PARTS LIST

| REF# | PART#     | DESCRIPTION              | QUANTITY |
|------|-----------|--------------------------|----------|
| 1    | 77-223    | Timer                    | 1        |
| 2    | 30-042-06 | Glo Relay                | 1        |
| 3    | 30-042-06 | Power Relay              | 1        |
| 4    |           | Fuel Pump                | 1        |
| 5    |           | Fuel Solenoid            | 1        |
| 6    |           | Alternator               | 1        |
| 7    | 33-216    | Battery                  | 1        |
|      | 8-603     | Battery Strap            | 1        |
| 8    | 76-327    | Negative Battery Cable   | 1        |
| 9    | 75-518    | Red Battery Cable        | 1        |
| 10   |           | Starter                  | 1        |
| 11   | 77-261    | 40Amp Breaker            | 2        |
|      | 8977      | Red Circuit Breaker Boot | 2        |
| 12   | 18-372    | 3-Way Ball Valve         | 1        |
| 13   | 33-271    | Buss Fuse Block          | 1        |

Diagrams

# HYDRAULIC DIAGRAM

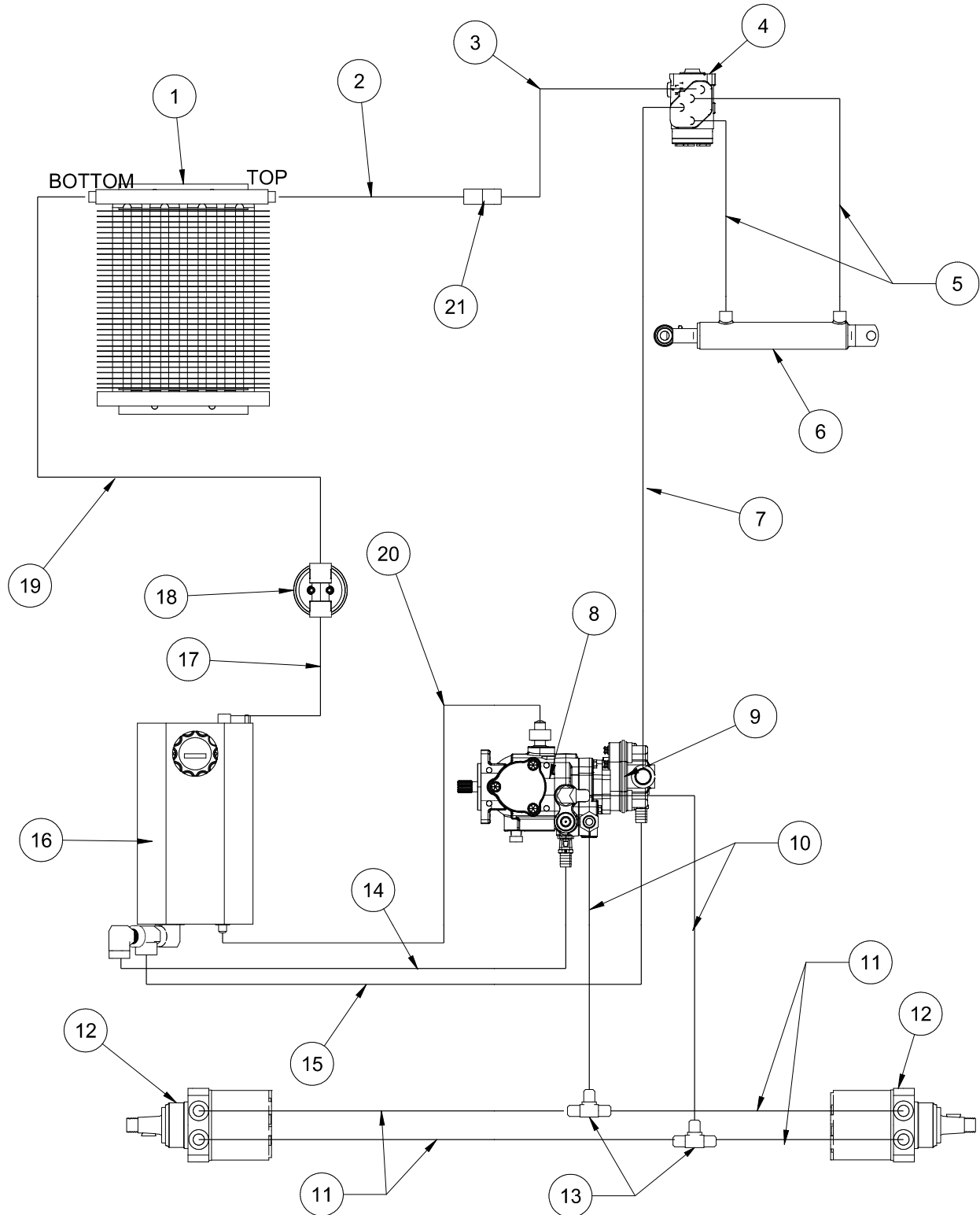

Diagrams



## HYDRAULIC DIAGRAM PARTS LIST

| REF# | PART#     | DESCRIPTION                                      | QUANTITY |
|------|-----------|--|----------|
| 1    | 15-624    | Cooler   | 1        |
| 2    | 20-867    | Hydraulic Hose, 12.5"                            | 1        |
| 3    | 15-946    | Hydraulic Hose, 74"                              | 1        |
| 4    | 15-301    | Orbital  | 1        |
| 5    | 10-671    | Hydraulic Hose, 65"                              | 2        |
| 6    | 15-839    | Hydraulic Cylinder                               | 1        |
|      | 15-839-01 | Seal Kit   | 1        |
| 7    | 15-945    | Hydraulic Hose, 76.5"                            | 1        |
| 8    | 76-638    | Hydrostatic Pump                                 | 1        |
| 9    | 76-197    | Gear Pump  | 1        |
| 10   | 15-682    | Hydraulic Hose, 46 <sup>3</sup> / <sub>4</sub> " | 2        |
| 11   | 20-656    | Tube Assembly                                    | 4        |
| 12   | 76-238    | Wheel Motor                                      | 2        |
| 13   | 34-057    | Tee  | 2        |
| 14   | 8832      | <sup>3</sup> / <sub>4</sub> " Suction Hose x 29" | 29"      |
|      | 18-040    | Hose Clamp                                       | 2        |
| 15   | 8832      | <sup>3</sup> / <sub>4</sub> " Suction Hose x 30" | 30"      |
|      | 18-040    | Hose Clamp                                       | 2        |
| 16   | 60-473    | Hydraulic Oil tank                               | 1        |
| 17   | 8917      | <sup>3</sup> / <sub>8</sub> " Suction Hose x 16" | 16"      |
|      | 18-040    | Hose Clamp                                       | 2        |
| 18   | 26-016    | Oil Filter                                       | 1        |
|      | 23-031    | Replacement Filter                               | 1        |
| 19   | 20-868    | Hydraulic Hose, 22.5"                            | 1        |
| 20   | 15-981    | Hydraulic Hose, 32"                              | 1        |
| 21   | 18-410    | Union  | 1        |

## PUMP DISPLACEMENT

### 76-638 Hydrostatic Pump

|                             |  |
|-----------------------------|--|
| Displacement                | Variable to 1.44 in <sup>3</sup> /R (23.6 cm <sup>3</sup> /R)<br>22.44 gpm (84.94 lpm) at 3600 rpm |
| Max Operating Speed         | 3600 rpm   |
| Rated Pressure              | 3000 psi (206.8 bar)   |
| Max Pressure                | 5000 psi (344.7 bar)   |
| Max Inlet Vacuum            | 6 in Hg (.203 bar)   |
| Max Inlet Temperature       | 225°F (107°C)  |
| Max Allowable Case Pressure | 25 psi (1.72 bar)  |

### 76-197 Gear Pump

|              |  |
|--------------|--|
| Displacement | .40 in <sup>3</sup> /R (6.6 cm <sup>3</sup> /R) 6.23 gpm (25.39 lpm) |
|--------------|--|



**CAUTION**

Over tightened fittings will result in crushing the cone which will create a leak.

# BODY & FRAME DRAWING

Parts

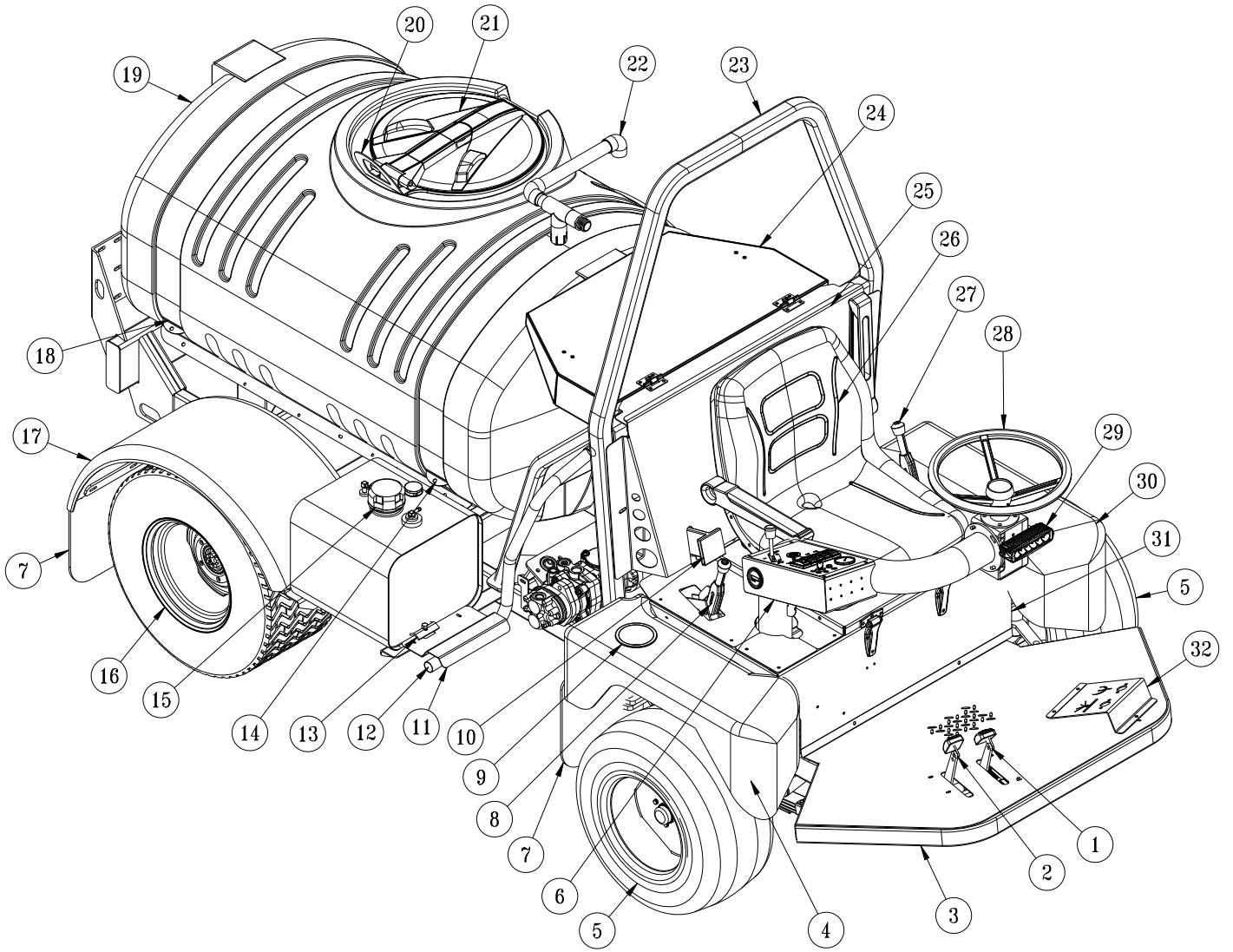

## BODY & FRAME PARTS LIST

| REF# | PART#     | DESCRIPTION                    | QUANTITY |
|------|-----------|--------------------------------|----------|
| 1    | 10-678    | Reverse Pedal                  | 1        |
|      | 45-022    | Molded Foot Pedal              | 1        |
| 2    | 10-677    | Forward Pedal                  | 1        |
|      | 45-022    | Molded Foot Pedal              | 1        |
| 3    | 20-875    | Main Frame                     | 1        |
| 4    | 30-404    | RH Front Fender                | 1        |
| 5    | 16-857    | Front Tire and Wheel           | 2        |
|      | 16-857-01 | Tire, 20 x 10.00 - 10NHS 4 Ply | 2        |
|      | 42-161-02 | Wheel                          | 2        |
| 6    | 10-683    | Side Control Arm               | 1        |
|      | 10-684    | Control Panel                  | 1        |
| 7    | 20-659    | Mud Flap                       | 4        |
| 8    | 60-106    | Park Brake Handle              | 1        |
| 9    | 15-781    | Drink Cup Holder               | 1        |
| 10   | 76-198-03 | Seat Belt                      | 1        |
| 11   | 20-884    | Exhaust Pipe Guard             | 1        |
| 12   | 20-871    | Exhaust Pipe                   | 1        |
| 13   | 75-792    | Tank Hold Down                 | 3        |
| 14   | 20-812    | Front Tank Strap               | 1        |
| 15   | 20-692    | 10 Gallon Fuel Tank            | 1        |
|      | 20-694    | Fuel Cap                       | 1        |
| 16   | 16-225    | Rear Tire and Wheel            | 2        |
|      | 16-225-01 | Tire, 24 x 13.00 - 12NHS 4 Ply | 2        |
|      | 16-225-02 | Wheel                          | 2        |
| 17   | 10-168    | Rear Fender                    | 2        |
| 18   | 20-811    | Rear Tank Strap                | 1        |
| 19   | 20-802    | 200 Gallon Spray Tank          | 1        |
|      | 16-169    | Strainer Basket                | 1        |
| 20   | 10-639    | Lid Stop                       | 1        |
| 21   | 16-953    | Lid                            | 1        |
|      | 16-953-01 | Gasket for Lid                 | 1        |
| 22   | 15-964    | Air Gap Filler                 | 1        |
| 23   | 20-886    | Roll Bar                       | 1        |
|      | 20-888    | RH Roll Bar Leg                | 1        |
|      | 20-890    | LH Roll Bar Leg                | 1        |
| 24   | 15-936    | Engine Hood                    | 1        |
| 25   | 15-934    | Back Panel                     | 1        |
| 26   | 14-294    | Seat kit                       | 1        |
|      | 10-706    | Arm Rests                      | 1        |
| 27   | 10-120    | Speed Boss Handle              | 1        |
| 28   | 20-057    | Steering Wheel                 | 1        |
|      | 20-129    | Center Steering Wheel Cap      | 1        |
| 29   | 20-912    | LED Head Light                 | 1        |
| 30   | 30-405    | LH Front Fender                | 1        |
| 31   | 10-680    | Seat Frame                     | 1        |
| 32   | 10-705    | Foot Rest                      | 1        |



# ENGINE HOOD & ROLL BAR DRAWING

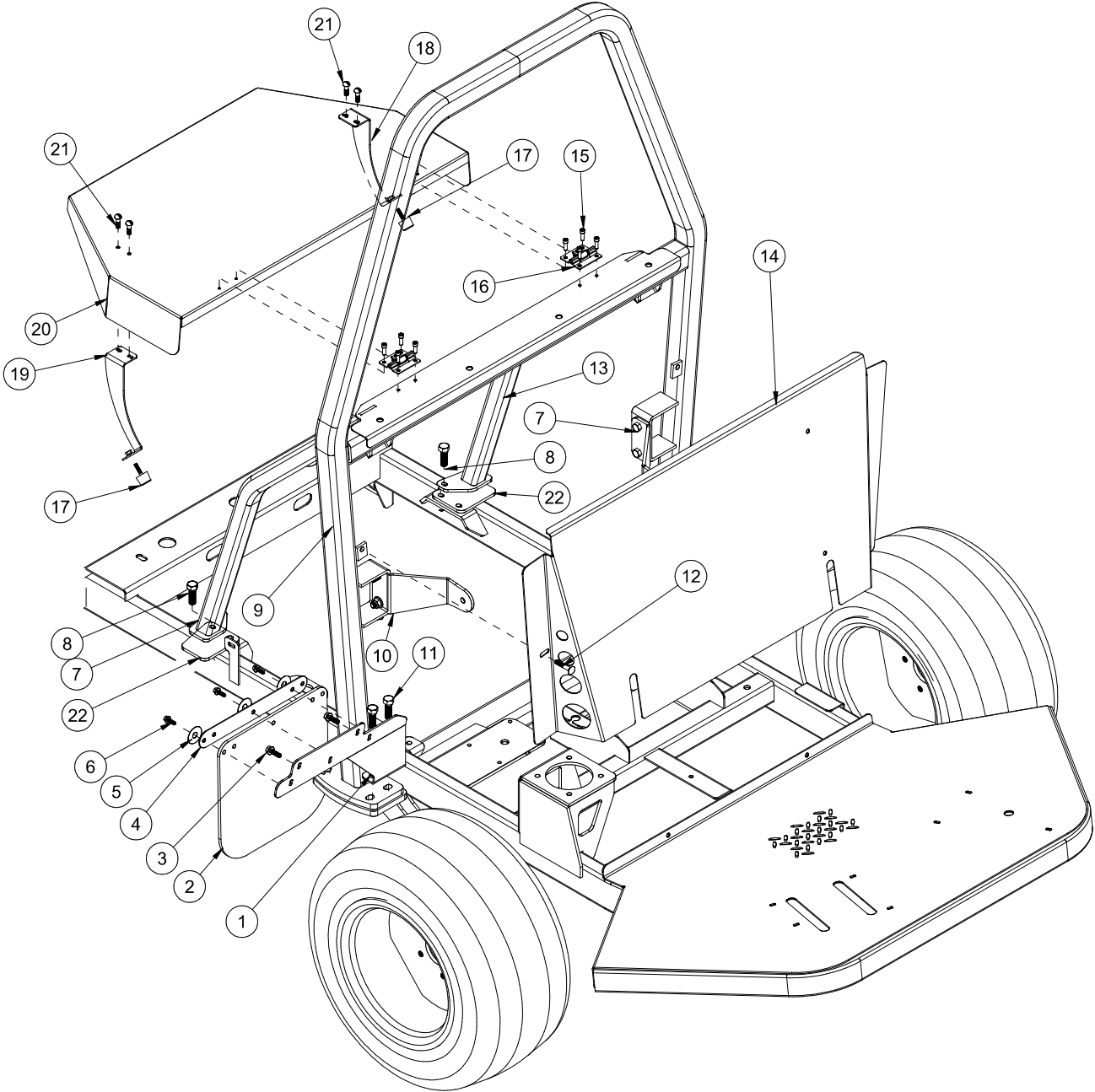

PARTS

## ENGINE HOOD AND ROLL BAR PARTS LIST

| REF# | PART#           | DESCRIPTION  | QUANTITY |
|------|-----------------|--|----------|
| 1    | 15-940          | RH Fender Brace                                      | 1        |
|      | 15-939          | LH Fender Brace (not shown)                          | 1        |
| 2    | 20-659          | Mud Flap   | 2        |
| 3    | HBC-516-18-100  | Carriage Bolt, $\frac{5}{16}$ -18 x 1                | 4        |
|      | HNFL-516-18     | Flange-Loc Nut, $\frac{5}{16}$ - 18                  | 4        |
| 4    | 20-660          | Mud Flap Strap                                       | 2        |
| 5    | HWF-14-150      | Fender Washer, $\frac{1}{4}$ x $1\frac{1}{2}$        | 6        |
| 6    | HB-14-20-075    | Hex Bolt, $\frac{1}{4}$ -20 x $\frac{3}{4}$          | 6        |
|      | HNFL-14-20      | Flange-Loc Nut, $\frac{1}{4}$ - 20                   | 6        |
| 7    | 20-888          | RH Roll Bar Leg                                      | 1        |
| 8    | HB-38-16-150    | Hex Bolt, $\frac{3}{8}$ - 16 x $1\frac{1}{2}$        | 2        |
|      | HNTL-38-16      | Lock Nut, $\frac{3}{8}$ - 16                         | 2        |
| 9    | 20-886          | Roll Bar   | 1        |
| 10   | 15-935          | Seat Belt Bracket                                    | 2        |
|      | HB-12-13-150    | Hex Bolt, $\frac{1}{2}$ - 13 x $1\frac{1}{2}$        | 4        |
|      | HNTL-12-13      | Lock Nut, $\frac{1}{2}$ - 13                         | 4        |
| 11   | HB-12-13-175    | Hex Bolt, $\frac{1}{2}$ - 13 x $1\frac{3}{4}$        | 10       |
|      | HW-12           | Flat Washer, $\frac{1}{2}$                           | 10       |
|      | HNTL-12-13      | Lock Nut, $\frac{1}{2}$ - 13                         | 10       |
| 12   | HB-38-16-075    | Hex Bolt, $\frac{3}{8}$ -16 x $\frac{3}{4}$          | 2        |
|      | HNFL-38-16      | Flange-Loc Nut, $\frac{3}{8}$ -16                    | 2        |
| 13   | 20-890          | LH Roll Bar Leg                                      | 1        |
| 14   | 15-934          | Back Panel   | 1        |
|      | 9023            | Heat Reflective Matting (18 x 25.5)                  | 1 Sheet  |
| 15   | HSM-10-32-063   | Machine Screw, 10-32 x $\frac{5}{8}$                 | 8        |
|      | HNFL-10-32      | Flange-Loc Nut, 10 - 32                              | 8        |
| 16   | 32-695          | Adjustable Hinge                                     | 2        |
| 17   | 15-013          | Rubber Bumper  | 2        |
|      | HNFL-14-20      | Flange-Loc Nut, $\frac{1}{4}$ - 20                   | 2        |
| 18   | 20-879          | LH Hood Stand  | 1        |
| 19   | 20-880          | RH Hood Stand  | 1        |
| 20   | 15-936          | Engine Hood  | 1        |
|      | 25-371          | Decal, Diesel  | 2        |
| 21   | HSTP-516-18-075 | Truss Head Screw, $\frac{5}{16}$ -18 x $\frac{3}{4}$ | 4        |
|      | HNFL-516-18     | Flange-Loc Nut, $\frac{5}{16}$ - 18                  | 4        |

# CONTROL PANEL AND STEERING DRAWING

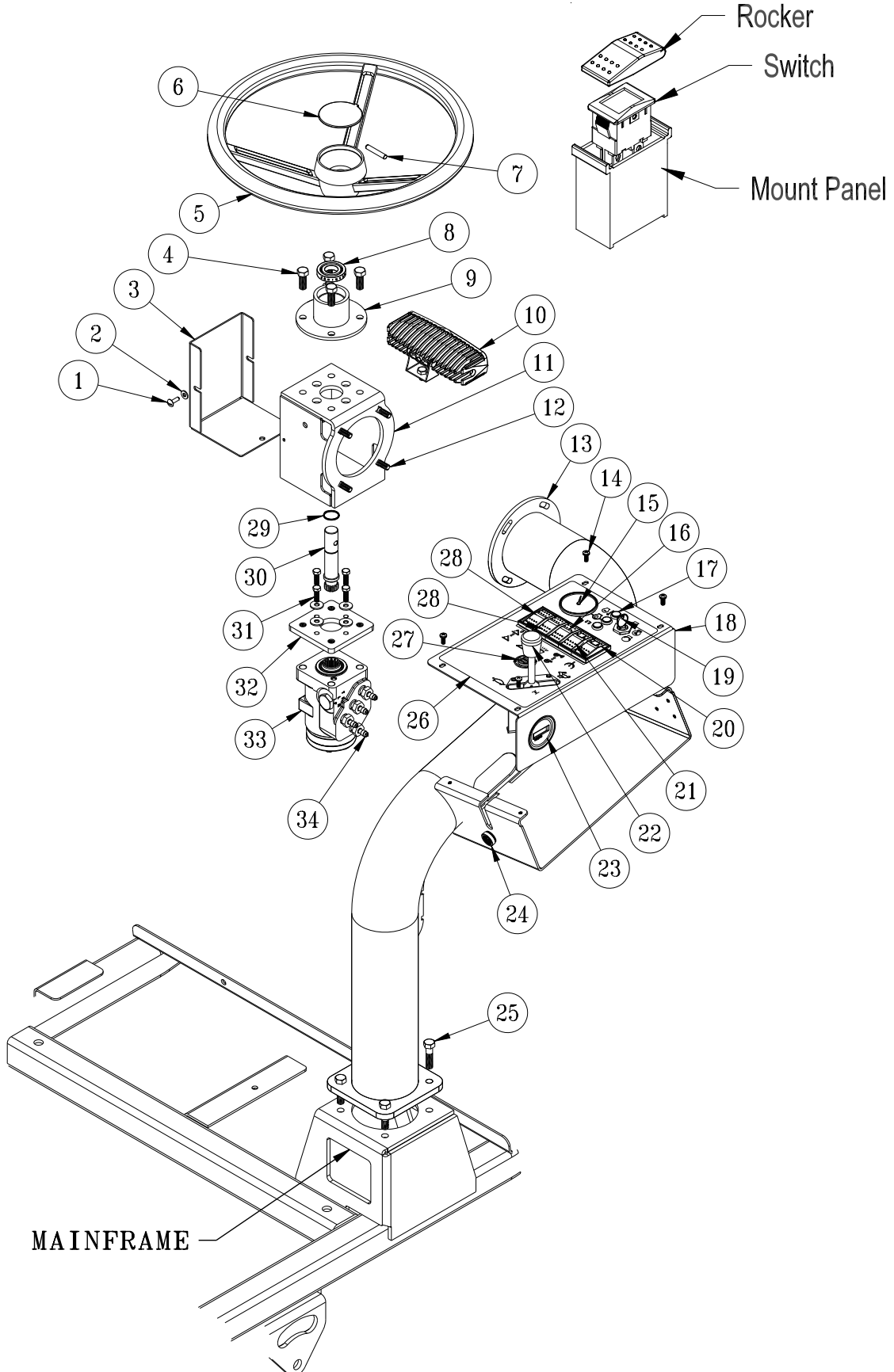

PARTS

# CONTROL PANEL AND STEERING PARTS LIST

| REF# | PART#          | DESCRIPTION                  | QUANTITY |
|------|----------------|------------------------------|----------|
| 1    | HSM-10-32-063  | Machine Screw, #10 -32 x 5/8 | 2        |
| 2    | HW-10          | Flat Washer, #10             | 2        |
| 3    | 10-704         | Steering Box Cover           | 1        |
| 4    | HB-38-16-100   | Hex Bolt, 3/8 -16 x 1        | 4        |
|      | HWL-38         | Lock Washer, 3/8             | 4        |
| 5    | 20-057         | Steering Wheel               | 1        |
| 6    | 20-129         | Steering Wheel Cap           | 1        |
| 7    | HRP-14-150     | Roll Pin, 1/4 x 1 1/2        | 1        |
| 8    | 10-711         | Ball Bearing                 | 1        |
| 9    | 10-698         | Steering Column              | 1        |
| 10   | 20-912         | LED Head Light               | 1        |
|      | HSM-10-32-063  | Machine Screw, #10-32 x 5/8  | 2        |
|      | HW-10          | Flat Washer, #10             | 2        |
|      | HNFL-10-32     | Flange Whiz-loc Nut, #10-32  | 2        |
| 11   | 10-682         | Steering Box                 | 1        |
| 12   | HBC-516-18-100 | Carriage Bolt, 5/16 - 18 x 1 | 4        |
|      | HNFL-516-18    | Flange-Loc Nut, 5/16 - 18    | 4        |
| 13   | 10-683         | Side Control Arm             | 1        |
| 14   | HSM-10-32-100  | Machine Screw, #10-32 x 1    | 4        |
|      | HNFL-10-32     | Flange-Loc Nut, #10-32       | 4        |
| 15   | 30-356         | GPS Speedometer w/Connectors | 1        |
| 16   | LED Head Light |                              |          |
|      | 15-727         | Rocker                       | 1        |
|      | 15-729         | Panel Mount Middle           | 1        |
|      | 15-782         | Switch, On-None-Off          | 1        |
| 17   | 50-359         | Warning Indicator Light      | 3        |
|      | 8853           | Female Spade Connector       | 1        |
|      | 8958           | Male Spade Connector         | 1        |
| 18   | 10-684         | Control Panel                | 1        |
| 19   | 13-488         | Ignition Switch              | 1        |
|      | 8-709          | Key Set                      | 1        |
| 20   | Cruise Control |                              |          |
|      | 15-732         | Green Rocker                 | 1        |
|      | 15-726         | Lighted Switch               | 1        |
|      | 15-725         | Panel Mount End              | 1        |
| 21   | Spray Pump     |                              |          |
|      | 15-731         | Amber Rocker                 | 1        |
|      | 15-729         | Panel Mount Middle           | 1        |
|      | 15-726         | Lighted Switch               | 1        |
| 22   | 45-118         | Throttle Cable               | 1        |
| 23   | 12-804         | Hour Meter                   | 1        |
| 24   | 77-207         | Buzzer                       | 1        |
|      | 8875           | Male Bullet                  | 1        |
|      | 8874           | Female Bullet                | 1        |
|      | 8963           | Heat Shrink                  | 2        |
| 25   | HB-38-16-100   | Hex Bolt, 3/8-16-100         | 4        |
|      | HWL-38-16      | Lock Washer, 3/8             | 4        |
| 26   | 20-866         | Decal, Control Panel         | 1        |
| 27   | 32-576         | Dual USB Power Charger       | 1        |
| 28   | RH & LH Booms  |                              |          |
|      | 15-725         | Panel Mount End              | 1        |
|      | 15-729         | Panel Mount Middle           | 1        |
|      | 15-727         | Rocker                       | 2        |
|      | 15-728         | Centering Switch, On-Off-On  | 2        |
| 29   | HRR-075        | Retaining Ring, 3/4"         | 1        |
| 30   | 10-708         | Splined Steering Shaft       | 1        |
| 31   | HBM-6-1-20     | Metric Bolt, #6 - 1 x 20     | 4        |
| 32   | 10-689         | Orb Adapter                  | 1        |
| 33   | 15-301         | Orbtinol                     | 1        |
| 34   | 18-169         | 3/8 Adapter Fitting          | 4        |

# FOOT PEDAL LINKAGE DRAWING

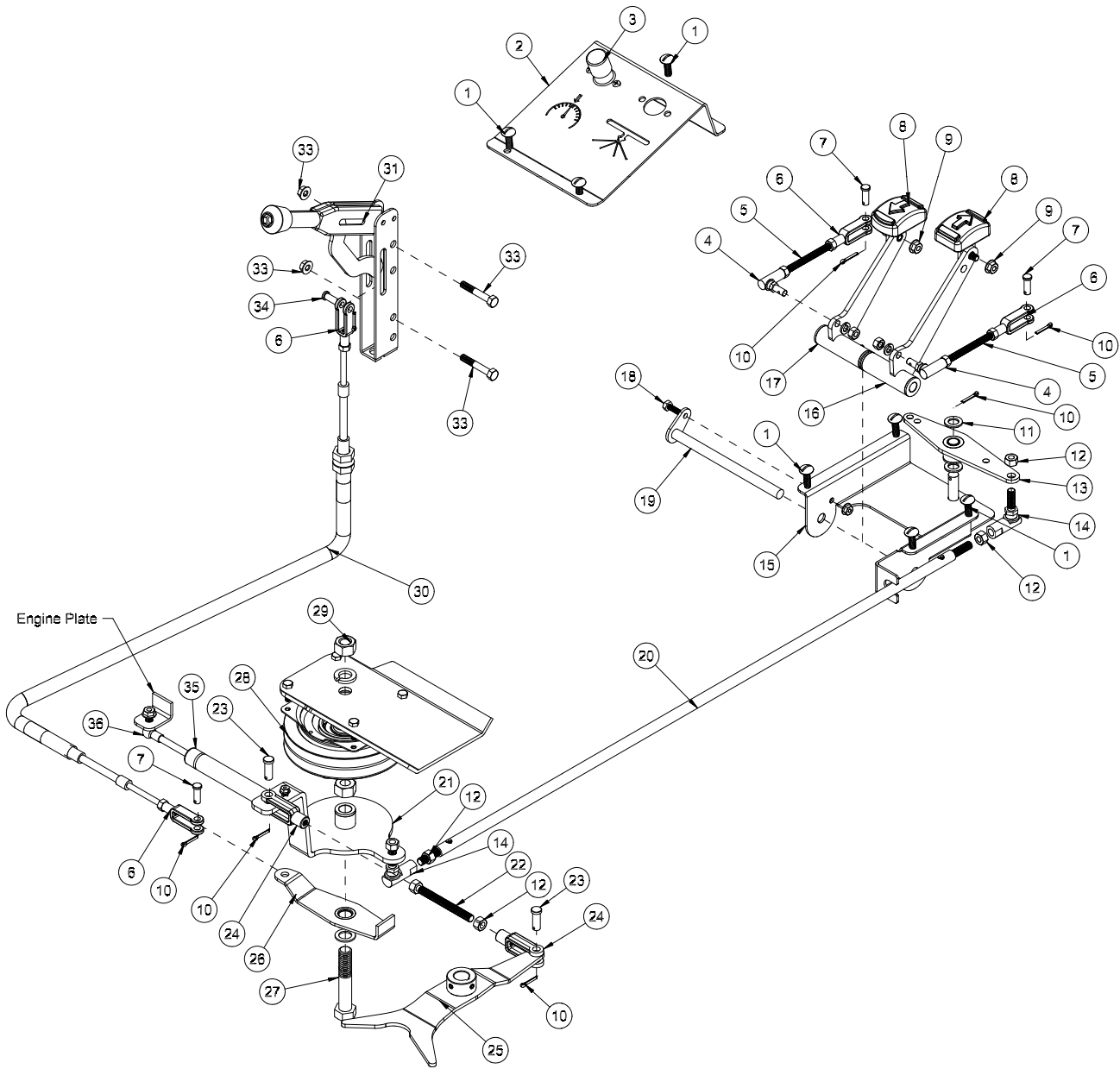



## FOOT PEDAL LINKAGE PARTS LIST

| REF# | PART#           | DESCRIPTION  | QUANTITY |
|------|-----------------|--|----------|
| 1    | HSTP-516-18-100 | Truss Head Screw, <sup>5</sup> / <sub>16</sub> - 18 x 1                              | 7        |
|      | HNTL-516-18     | Lock Nut <sup>5</sup> / <sub>16</sub> - 18   | 7        |
| 2    | 10-705          | Foot Rest  | 1        |
| 3    | 33-509          | Cruise Control Foot Switch   | 1        |
| 4    | 21-462          | Ball Joint, <sup>5</sup> / <sub>16</sub> -24   | 2        |
|      | HN-516-24       | Hex Nut, <sup>5</sup> / <sub>16</sub> - 24   | 2        |
|      | HWL-516         | Lock Washer, <sup>5</sup> / <sub>16</sub>  | 2        |
| 5    | 10-598          | Connector Rod  | 2        |
|      | HN-516-24       | Hex Nut, <sup>5</sup> / <sub>16</sub> - 24   | 4        |
| 6    | 11-100          | Yoke, <sup>5</sup> / <sub>16</sub> - 24  | 4        |
| 7    | HCP-516-100     | Clevis Pin, <sup>5</sup> / <sub>16</sub> x 1   | 4        |
| 8    | 45-022          | Molded Foot Pedal  | 2        |
| 9    | HBFL-516-18-075 | Flange Whiz-loc Bolt, <sup>5</sup> / <sub>16</sub> -18 x <sup>3</sup> / <sub>4</sub> | 2        |
|      | HNFL-516-18     | Flange Whiz-loc Nut, <sup>5</sup> / <sub>16</sub> -18                                | 2        |
| 10   | HP-18-100       | Cotter Pin, <sup>1</sup> / <sub>8</sub> x 1  | 5        |
| 11   | HMB-12-14       | Machine Bushing, <sup>1</sup> / <sub>2</sub> x 14GA                                  | 2        |
| 12   | HN-38-24        | Hex Nut, <sup>3</sup> / <sub>8</sub> - 24  | 6        |
| 13   | 15-924          | Pedal Relay  | 1        |
| 14   | 21-173          | Ball Joint, <sup>3</sup> / <sub>8</sub> -24  | 2        |
| 15   | 10-674          | Pedal Mount  | 1        |
| 16   | 10-677          | Forward Pedal Assembly   | 1        |
|      | 76-128          | Bushing  | 2        |
|      | HG-14-28-180    | Grease Zerk  | 1        |
| 17   | 10-678          | Reverse Pedal Assembly   | 1        |
|      | 76-128          | Bushing  | 2        |
|      | HG-14-28-180    | Grease Zerk  | 1        |
| 18   | HB-14-20-075    | Hex Bolt, <sup>1</sup> / <sub>4</sub> - 20 x <sup>3</sup> / <sub>4</sub>             | 1        |
|      | HNFL-14-20      | Flange Whiz-loc Nut, <sup>1</sup> / <sub>4</sub> - 20                                | 1        |
| 19   | 10-673          | Pedal Pivot  | 1        |
| 20   | 15-926          | Control Link   | 1        |
| 21   | 15-923          | Control Relay  | 1        |
| 22   | 52-133          | Brake Rod  | 1        |
| 23   | HCP-38-113      | Clevis Pin, <sup>3</sup> / <sub>8</sub> x <sup>1</sup> / <sub>8</sub>                | 2        |
| 24   | 21-351          | Linkage Yoke, <sup>3</sup> / <sub>8</sub> -24  | 2        |
| 25   | 20-652          | Shift Arm  | 1        |
| 26   | 15-927          | Speed Boss Arm   | 1        |
| 27   | HB-58-11-400    | Hex Bolt, <sup>5</sup> / <sub>8</sub> -11x 4   | 1        |
|      | HMB-58-14       | Machine Bushing, <sup>5</sup> / <sub>8</sub> x 14GA                                  | 3        |
| 28   | 33-084          | Magnetic Coil  | 1        |
| 29   | HN-58-11        | Hex Nut, <sup>5</sup> / <sub>8</sub> -11   | 2        |
|      | HWL-58          | Lock Washer, <sup>5</sup> / <sub>8</sub>   | 1        |
| 30   | 10-658          | Speed Boss Cable   | 1        |
| 31   | 10-120          | Spray Boss Handle  | 1        |
| 33   | HB-516-18-200   | Hex Bolt, <sup>5</sup> / <sub>16</sub> -18 x 2                                       | 2        |
|      | HNTL-516-18     | Lock Nut, <sup>5</sup> / <sub>16</sub> - 18  | 2        |
| 34   | HCP-14-075      | Clevis Pin, <sup>1</sup> / <sub>4</sub> x <sup>3</sup> / <sub>4</sub>                | 1        |
|      | HP-18-100       | Cotter Pin, <sup>1</sup> / <sub>8</sub> x 1  | 1        |
| 35   | 20-649          | Dampner  | 1        |
| 36   | 26-034          | Ball Stud  | 1        |
|      | HNFL-10-32      | Flange Whiz-loc Nut, #10- 32   | 1        |

# FRONT AXLE DRAWING

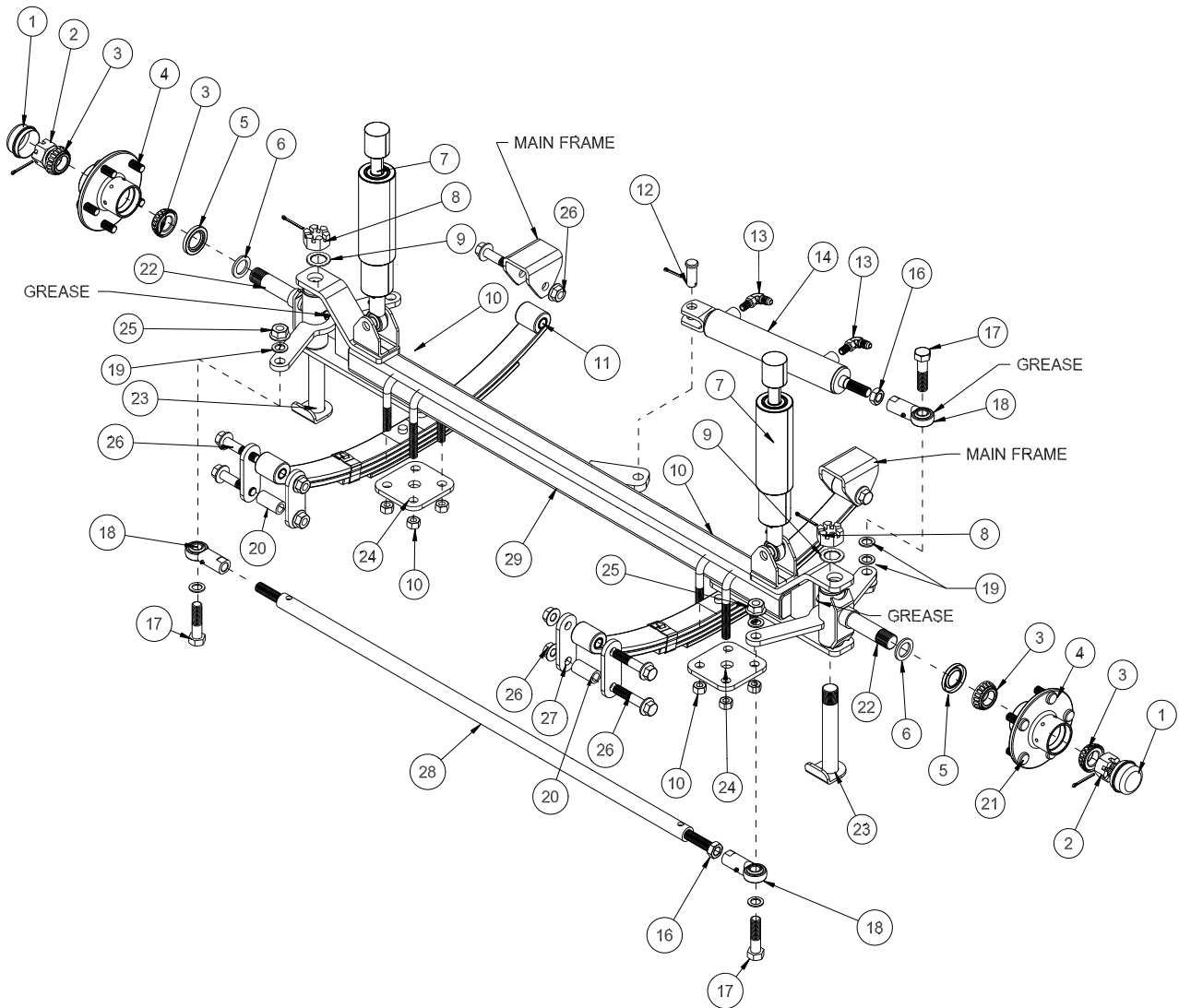

PARTS

# FRONT AXLE PARTS LIST

| REF# | PART#         | DESCRIPTION                      | QUANTITY |
|------|---------------|----------------------------------|----------|
| 1*   | 33-073-02     | Dust Cap                         | 2        |
| 2    | HNAR-100-14   | Slotted Jam Nut, 1 - 14          | 2        |
|      | HP-18-150     | Cotter Pin, 1/8 - 1 1/2          | 2        |
| 3*   | 11-043        | Bearing                          | 4        |
| 4    | 80-019        | Hub (includes * items )          | 2        |
| 5*   | 11-041        | Oil Seal                         | 2        |
| 6    | HMB-100-10    | Machine Bushing, 1 x 10GA        | 2        |
| 7    | 20-617        | Shock Absorbers                  | 2        |
| 8    | HNA-100-14    | Slotted Nut, 1 - 14              | 2        |
|      | HP-18-150     | Cotter Pin, 1/8 - 1 1/2          | 2        |
| 9    | HMB-100-14    | Machine Bushing, 1 x 14GA        | 2        |
| 10   | 20-555        | U-bolt                           | 4        |
|      | HNTL-12-13    | Lock Nut, 1/2 - 13               | 8        |
| 11   | 20-740        | Leaf Spring                      | 2        |
| 12   | HCP-58-175    | Clevis Pin, 5/8 - 1 3/4          | 1        |
|      | HP-18-100     | Cotter Pin, 1/8 x 1              | 1        |
| 13   | 18-168        | 90° Elbow                        | 2        |
| 14   | 15-839        | Hydraulic Cylinder               | 1        |
|      | 15-839-01     | Seal Kit                         | 1        |
| 16   | HNJ-58-18     | Jam Nut, 5/8 - 18                | 3        |
| 17   | HB-58-11-250  | Bolt, 5/8 - 11 x 2 1/2           | 3        |
| 18   | 18-154        | Rod End                          | 3        |
|      | HG-14-28-180  | Grease Fitting, 1/4 - 28 x 180°  | 3        |
| 19   | HMB-58-14     | Machine Bushing, 5/8 x 14GA      | 6        |
| 20   | 30-251        | Bushing (pressed in mainframe)   | 2        |
| 21   | 60-268        | Stud, 1/2 - 20 x 1 5/16          | 10       |
| 22   | 10-582        | Spindle                          | 2        |
|      | 18-035        | Bushing (part of Spindle; 2 per) | 4        |
|      | HG-14-28-45   | Grease Fitting, 1/4 - 28 x 45°   | 2        |
| 23   | 16-076        | King Pin                         | 2        |
| 24   | 20-538        | Spring Mount                     | 2        |
| 25   | HNTL-58-11    | Lock Nut, 5/8 - 11               | 3        |
| 26   | HB-916-18-325 | Hex Bolt, 9/16 - 18 x 3 1/4      | 6        |
|      | HNTL-916-18   | Lock Nut, 9/16 - 18              | 6        |
| 27   | 15-930        | Shackle                          | 4        |
| 28   | 10-583        | Steering Link                    | 1        |
| 29   | 10-629        | Front Axle                       | 1        |

# OIL AND FUEL TANK DRAWING

PARTS

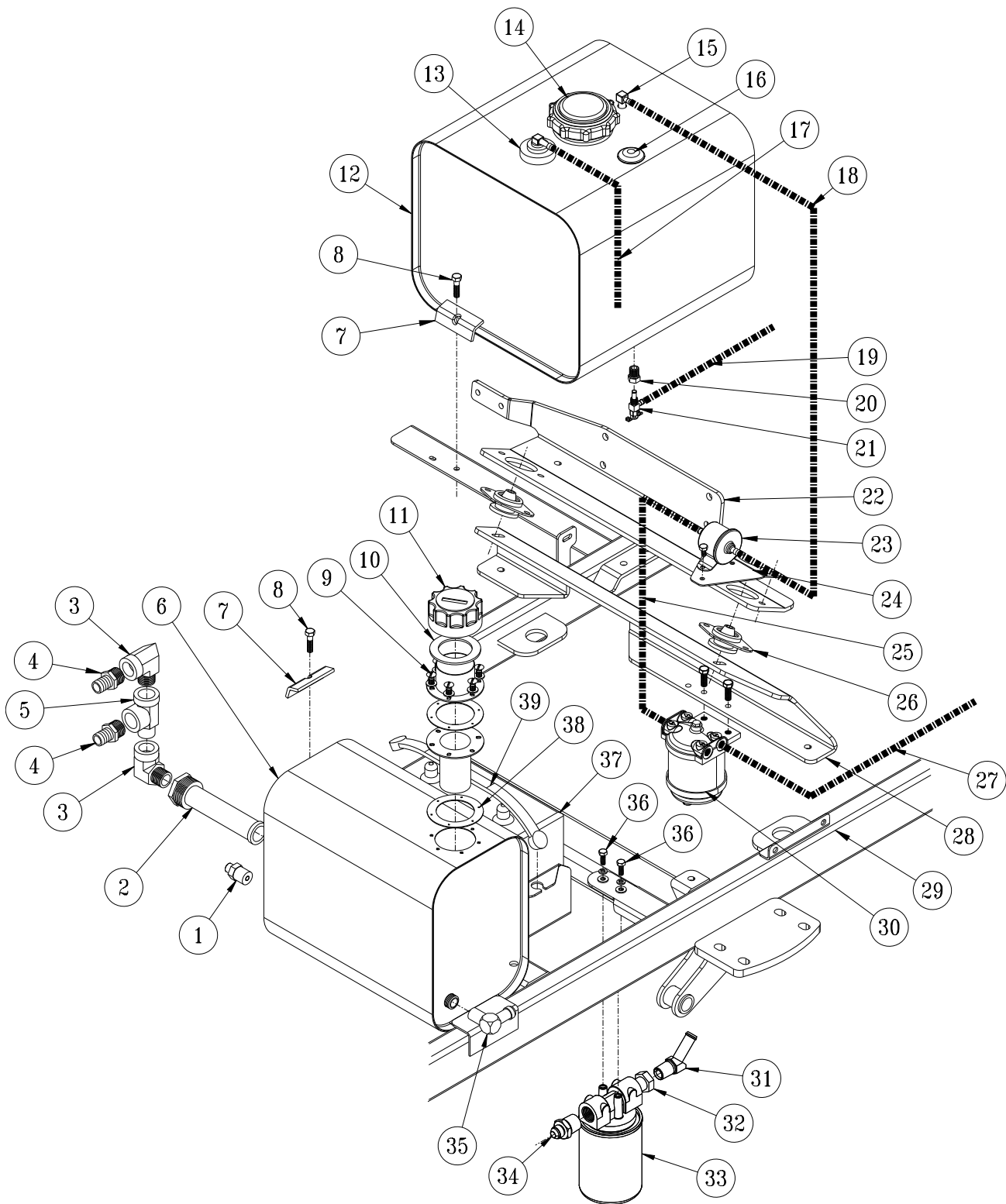

# OIL AND FUEL TANK PARTS LIST

| REF# | PART#         | DESCRIPTION                                    | QUANTITY |
|------|---------------|--|----------|
| 1    | 23-184        | Fitting  | 1        |
| 2    | 60-213        | Strainer                                       | 1        |
| 3    | 18-140        | Street Elbow                                   | 2        |
| 4    | 18-249        | Barb Fitting                                   | 2        |
| 5    | 18-093        | Straight Tee                                   | 1        |
| 6    | 60-473        | Oil Tank                                       | 1        |
| 7    | 75-792        | Tank Hold Down                                 | 3        |
| 8    | HB-516-18-150 | Hex Bolt, $\frac{5}{16}$ - 18 x $1\frac{1}{2}$ | 3        |
|      | HW-516        | Flat Washer, $\frac{5}{16}$                    | 6        |
|      | HNFL-516-18   | Flange Whiz-loc Nut, $\frac{5}{16}$ - 18       | 3        |
| 9    | 13-586-03     | Filler Neck                                    | 1        |
|      | HSM-10-32-063 | Machine Screw, 10-32 x $\frac{5}{8}$           | 6        |
|      | HWL-10        | Lock Washer, #10                               | 6        |
| 10   | 13-586-01     | Cap Gasket                                     | 1        |
| 11   | 13-747        | Filler Breather                                | 1        |
| 12   | 20-692        | 10 Gallon Gas Tank                             | 1        |
| 13   | 42-814-05     | Rollover Valve                                 | 1        |
|      | 42-814-06     | Valve Grommet                                  | 1        |
| 14   | 20-694        | Cap  | 1        |
| 15   | 20-692-01     | Top Draw                                       | 1        |
|      | 42-814-07     | Top Draw Grommet                               | 1        |
| 16   | 20-692-02     | Fuel Gauge                                     | 1        |
|      | 20-692-03     | Grommet  | 1        |
| 17   | 8800          | Fuel Line, $\frac{1}{4}$ "                     | 19"      |
|      | 18-186        | Hose Clamp                                     | 2        |
| 18   | 8800          | Fuel Line, $\frac{1}{4}$ "                     | 56"      |
|      | 18-186        | Hose Clamp                                     | 2        |
| 19   | 9025          | Fuel Line, $\frac{5}{16}$ "                    | 48"      |
|      | 18-116        | Hose Clamp                                     | 2        |
| 20   | 18-042        | Reducer  | 1        |
| 21   | 15-039        | Shut-off Valve                                 | 1        |
| 22   | 20-873        | Front Engine Plate                             | 1        |
| 23   | 30-130        | Fuel Pump                                      | 1        |
| 24   | 20-619        | Fuel Pump Mount                                | 1        |
| 25   | 8800          | Fuel Line, $\frac{1}{4}$ "                     | 10"      |
| 26   | 20-618        | Rubber Insulator                               | 4        |
| 27   | 8800          | Fuel Line, $\frac{1}{4}$ "                     | 12"      |
|      | 18-186        | Hose Clamp                                     | 2        |
| 28   | 20-882        | Front Frame Adapter                            | 1        |
| 29   | 20-875        | Main Frame                                     | 1        |
| 30   |               | Fuel Filter                                    | 1        |
|      | 30-042-08     | Fuel Filter Element                            | 1        |
| 31   | 23-143        | Connector                                      | 1        |
| 32   | 18-008        | Pipe Thread Reducer                            | 1        |
| 33   | 26-016        | Oil Filter                                     | 1        |
|      | 23-031        | Replacement Filter                             | 1        |
| 34   | 18-243        | Male Connector                                 | 1        |
| 35   | 23-142        | Connector                                      | 1        |
| 36   | HB-14-20-075  | Hex Bolt, $\frac{1}{4}$ - 20 x $\frac{3}{4}$   | 2        |
|      | HW-14         | Flat Washer, $\frac{1}{4}$                     | 2        |
|      | HWL-14        | Lock Washer, $\frac{1}{4}$                     | 2        |
| 37   | 33-216        | Battery  | 1        |
| 38   | 13-586-02     | Bottom Gasket                                  | 1        |
| 39   | 8-603         | Battery Hold Down - Rubber Strap               | 1        |

# SEAT PANEL DRAWING

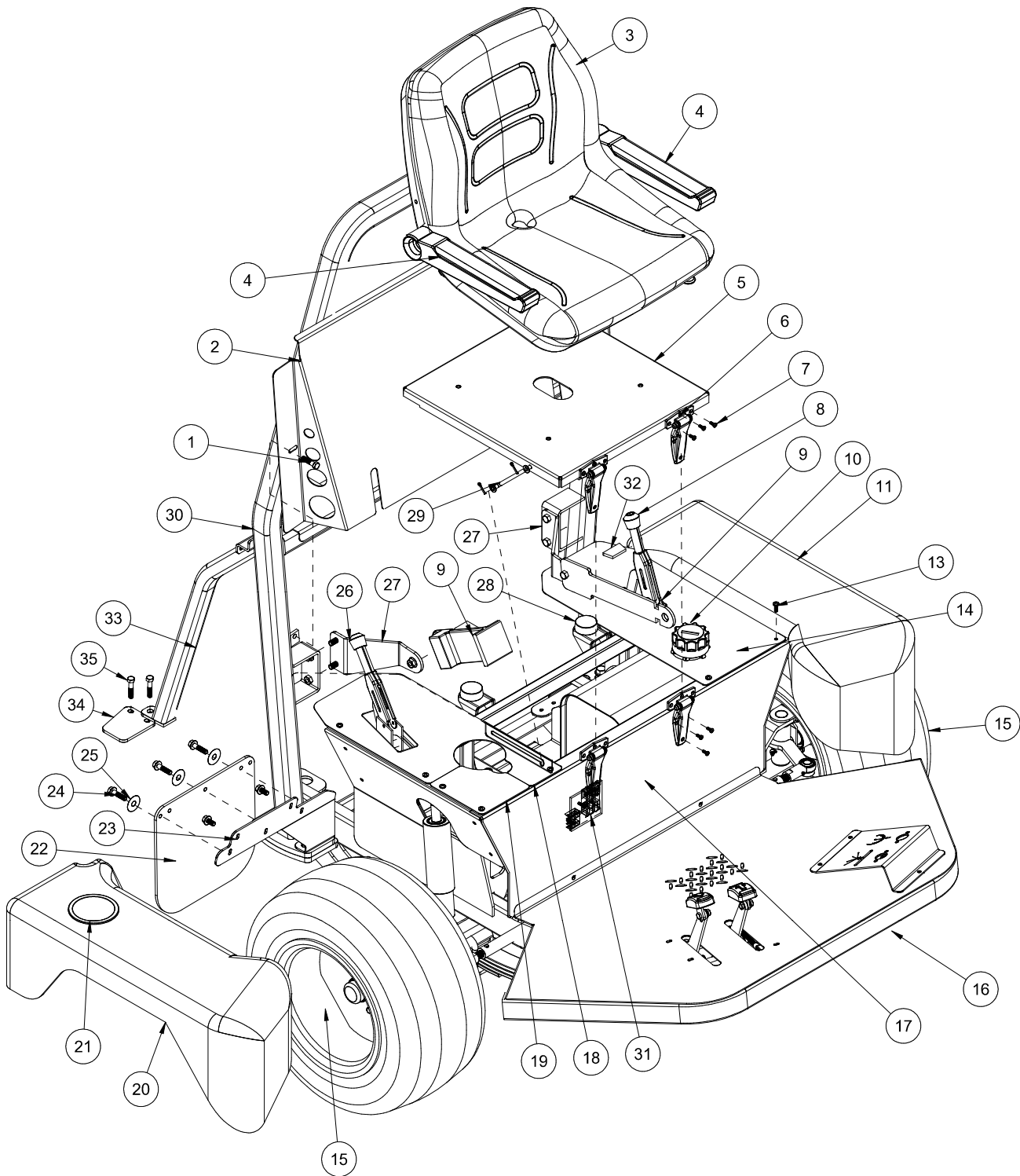

PARTS

# SEAT PANEL PARTS LIST

| REF# | PART#            | DESCRIPTION  | QUANTITY |
|------|------------------|--|----------|
| 1    | HSTP-516-18-075  | Truss Head Screw, $\frac{5}{16}$ -18 x $\frac{3}{4}$ | 2        |
|      | HNFL-516-18      | Flange-Loc Nut, $\frac{5}{16}$ - 18                  | 2        |
| 2    | 15-934           | Back Panel   | 1        |
|      | 9023             | Heat Reflective Matting                              | 1 Sheet  |
| 3    | 14-294           | Seat Kit   | 1        |
|      | 14-292           | Seat Switch  | 1        |
|      | 14-800           | Seat Rail  | 1        |
|      | HB-516-18-125    | Hex Bolt, $\frac{5}{16}$ - 18 x $1\frac{1}{4}$       | 4        |
|      | HW-516           | Flat Washer, $\frac{5}{16}$                          | 4        |
|      | HWL-516          | Lock Washer, $\frac{5}{16}$                          | 4        |
|      | HN-516-18        | Hex Nut, $\frac{5}{16}$ - 18                         | 4        |
| 4    | 10-706           | Arm Rest Kit   | 1        |
| 5    | 10-714           | Seat Panel   | 1        |
| 6    | 27-055           | Hinge  | 2        |
| 7    | HSMFCS-10-32-050 | Machine Screw, #10-32- $\frac{1}{2}$                 | 12       |
|      | HNFL-10-32       | Flange-Loc Nut, #10-32                               | 12       |
| 8    | 10-120           | Speed Boss Handle                                    | 1        |
| 9    | 76-198-03        | Seat Belt  | 1        |
| 10   | 13-747           | Filler Breather                                      | 1        |
|      | 60-473           | Oil Tank   | 1        |
| 11   | 30-405           | LH Front Fender                                      | 1        |
| 13   | HSDPS-14-100     | Pan Head Drill Screw, $\frac{1}{4}$ x 1              | 8        |
| 14   | 15-954           | LH Control Panel                                     | 1        |
| 15   | 16-857           | Tire and Wheel                                       | 2        |
|      | 16-857-01        | Tire, 20 x 10 - 10NHS 4 Ply                          | 2        |
|      | 42-161-02        | Wheel  | 2        |
| 16   | 20-875           | Main Frame   | 1        |
| 17   | 10-680           | Seat Frame   | 1        |
| 18   | 15-953           | RH Control Panel                                     | 1        |
| 19   | 10-694           | RH Panel Cover                                       | 1        |
| 20   | 30-404           | RH Front Fender                                      | 1        |
| 21   | 15-781           | Drink Cup Holder                                     | 1        |
| 22   | 20-659           | Mud Flap   | 2        |
| 23   | 15-940           | RH Fender Brace                                      | 1        |
|      | 15-939           | LH Fender Brace (not shown)                          | 1        |
|      | HBC-516-18-100   | Carriage Bolt, $\frac{5}{16}$ -18 x 1                | 8        |
|      | HNFL-516-18      | Flange-Loc Nut, $\frac{5}{16}$ - 18                  | 8        |
| 24   | HB-14-20-075     | Hex Bolt, $\frac{1}{4}$ -20 x $\frac{3}{4}$          | 6        |
|      | HNFL-14-20       | Flange-Loc Nut, $\frac{1}{4}$ - 20                   | 6        |
| 25   | HWF-14-150       | Fender Washer, $\frac{1}{4}$ x $1\frac{1}{2}$        | 6        |
| 26   | 60-106           | Park Brake Handle                                    | 1        |
| 27   | 15-935           | Seat Belt Bracket                                    | 2        |
|      | HB-12-13-125     | Hex Bolt, $\frac{1}{2}$ - 13 x $1\frac{1}{4}$        | 4        |
|      | HNTL-12-13       | Lock Nut, $\frac{1}{2}$ - 13                         | 4        |
| 28   | 50-081           | Rubber Bumper  | 2        |
|      | HNTL-38-16       | Lock Nut, $\frac{3}{8}$ - 16                         | 2        |
| 29   | 10-697           | Seat Prop Rod  | 1        |
|      | HW-38            | Flat Washer, $\frac{3}{8}$                           | 2        |
|      | HP-18-075        | Cotter Pin, $\frac{1}{8}$ x $\frac{3}{4}$            | 2        |
| 30   | 20-886           | Roll Bar   | 1        |
|      | HB-12-13-200     | Hex Bolt, $\frac{1}{2}$ - 13 x 2                     | 8        |
|      | HW-12            | Flat Washer, $\frac{1}{2}$                           | 8        |
|      | HNFL-12-13       | Flange Whiz-loc Nut, $\frac{1}{2}$ - 13              | 4        |
| 31   | 33-271           | Fuse Panel   | 1        |
| 32   | 20-730-01        | Speedometer Speed Sensor                             | 1        |
| 33   | 20-888           | RH Roll Bar Leg                                      | 1        |
|      | 20-890           | LH Roll Bar Leg (not shown)                          | 1        |

# ENGINE AND PUMP DRAWING

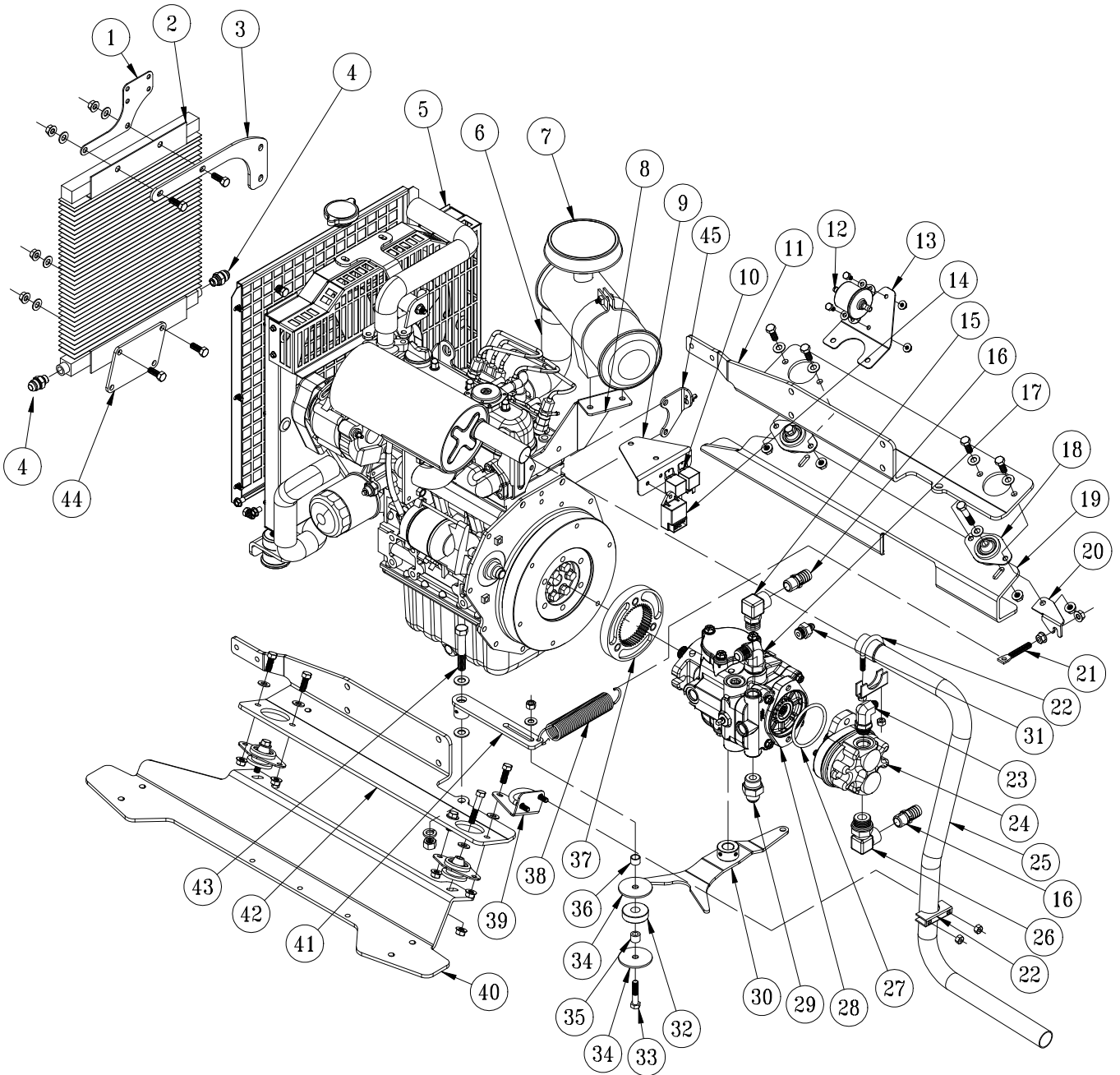

PARTS



# ENGINE AND PUMP PARTS LIST

| REF# | PART#         | DESCRIPTION                                    | QUANTITY |
|------|---------------|--|----------|
| 1    | 20-878        | Coolant Reservoir Mount                        | 1        |
| 2    | 15-624        | Oil Cooler                                     | 1        |
|      | HB-516-18-075 | Hex Bolt, $\frac{5}{16}$ - 18 x $\frac{3}{4}$  | 4        |
|      | HNFL-516-18   | Flange Whiz-loc Nut, $\frac{5}{16}$ - 18       | 4        |
| 3    | 20-876        | Upper Cooler Mount                             | 1        |
|      | HB-516-18-075 | Hex Bolt, $\frac{3}{8}$ - 16 x $\frac{3}{4}$   | 4        |
|      | HNFL-516-18   | Flange Whiz-loc Nut, $\frac{3}{8}$ - 16        | 4        |
| 4    | 18-509        | Straight Thread Connector                      | 2        |
| 5    | 20-614        | 25HP Kubota Diesel Engine                      | 1        |
| 6    | 42-776        | Air Inlet tube                                 | 1        |
|      | 18-116        | Hose Clamp                                     | 2        |
| 7    |               | Air Cleaner (comes with engine)                | 1        |
| 8    | 20-881        | Air Cleaner Mount                              | 1        |
| 9    | 20-622        | Timer/Relay Mount                              | 1        |
| 10   | 30-042-06     | Relay  | 2        |
|      | HB-14-20-075  | Hex Bolt, $\frac{1}{4}$ - 20 x $\frac{3}{4}$   | 2        |
|      | HNFL-14-20    | Flange Whiz-loc Nut, $\frac{1}{4}$ - 20        | 2        |
| 11   | 20-874        | Rear Engine Mount                              | 1        |
|      | HB-716-14-150 | Hex Bolt, $\frac{7}{16}$ - 14 x $1\frac{1}{2}$ | 2        |
|      | HWL-716       | Lock Washer, $\frac{7}{16}$                    | 2        |
| 12   | 30-130        | Fuel Pump                                      | 1        |
| 13   | 20-619        | Fuel Pump Mount                                | 1        |
| 14   | 77-223        | Lamp Timer                                     | 1        |
| 15   | 23-130        | Elbow  | 1        |
| 16   | 18-133        | Barb Fitting                                   | 2        |
| 17   | 18-204        | Elbow  | 1        |
| 18   | 20-618        | Rubber Insulator                               | 4        |
| 19   | 20-882        | Front Frame Adapter                            | 1        |
| 20   | 20-621        | Centering Spring Mount                         | 1        |
| 21   | 42-604        | Spade Hex Bolt                                 | 1        |
|      | HNFL-38-16    | Flange Whiz-loc Nut, $\frac{3}{8}$ - 16        | 2        |
| 22   | 18-220        | Muffler Clamp                                  | 2        |
| 23   | 18-458        | Straight Thread Elbow                          | 1        |
| 24   | 76-197        | Gear Pump                                      | 1        |
|      | HB-38-16-100  | Hex Bolt, $\frac{3}{8}$ - 16 x 1               | 2        |
|      | HW-38         | Flat Washer, $\frac{3}{8}$                     | 2        |
|      | HWL-38        | Lock Washer, $\frac{3}{8}$                     | 2        |
| 25   | 20-871        | Tailpipe                                       | 1        |
| 26   | 23-133        | 90° Adjustable Elbow                           | 1        |
| 27   | 23-145        | O-ring   | 1        |
| 28   | 76-638        | Hydrostatic Pump                               | 1        |
|      | HB-38-16-150  | Hex Bolt, $\frac{3}{8}$ - 16 x $1\frac{1}{2}$  | 2        |
|      | HW-38         | Flat Washer, $\frac{3}{8}$                     | 2        |
|      | HWL-38        | Lock Washer $\frac{3}{8}$                      | 2        |
| 29   | 15-702        | Adapter  | 1        |
| 30   | 20-652        | Shift Arm                                      | 1        |
| 31   | 18-241        | Straight Thrad Connector                       | 1        |
| 32   | 14-266        | Ball Bearing                                   | 1        |
| 33   | HB-38-16-175  | Hex Bolt, $\frac{3}{8}$ - 16 x $1\frac{3}{4}$  | 1        |
|      | HW-38         | Flat Washer, $\frac{3}{8}$                     | 1        |
|      | HNTL-38-16    | Nylon Lock Nut $\frac{3}{8}$ - 16              | 1        |

(Continued on Next Page)

# ENGINE AND PUMP DRAWING

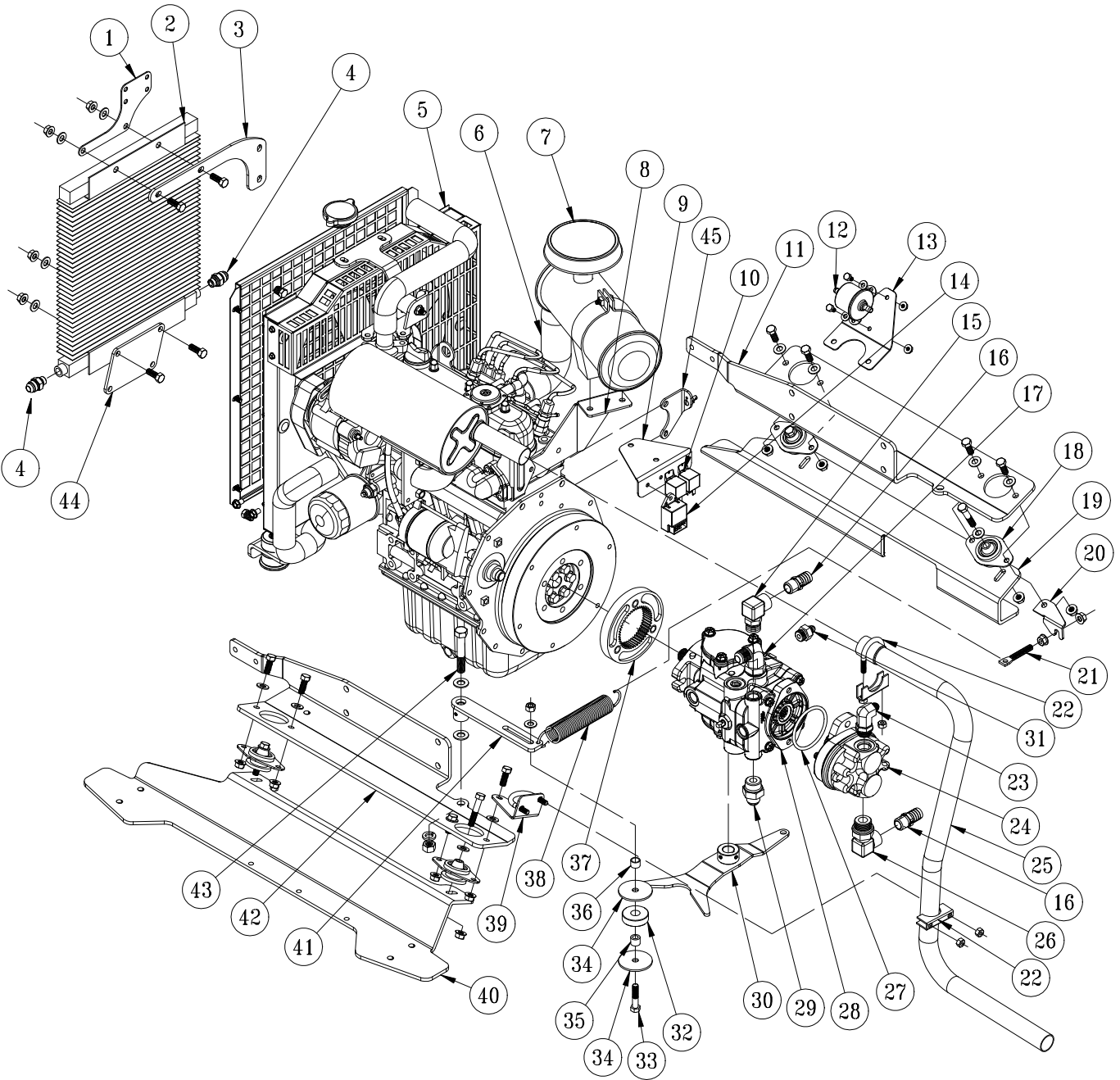

PARTS

## ENGINE AND PUMP PARTS LIST

| REF# | PART#         | DESCRIPTION                                     | QUANTITY |
|------|---------------|---|----------|
| 34   | 20-594        | Guide Disk                                      | 2        |
| 35   | 18-270        | Spacer  | 1        |
| 36   | 76-275        | Spacer  | 1        |
| 37   | 30-042-12     | Flange  | 1        |
| 38   | 21-445        | Spring  | 1        |
| 39   | 20-872        | Exhaust Pipe Mount                              | 1        |
| 40   | 20-883        | Rear Frame Adapter                              | 1        |
| 41   | 20-581        | Idler Arm                                       | 1        |
|      | HG-14-28-180  | Grease Zerk, $\frac{1}{4}$ -28 x 180°           | 1        |
| 42   | 20-873        | Front Engine Mount                              | 1        |
|      | HB-716-14-150 | Hex Bolt, $\frac{7}{16}$ - 14 x 1 $\frac{1}{2}$ | 2        |
|      | HWL-716       | Lock Washer, $\frac{7}{16}$                     | 2        |
| 43   | HB-12-13-300  | Hex Bolt, $\frac{1}{2}$ - 13 x 3                | 1        |
|      | HMB-12-14     | Machine Bushing, $\frac{1}{2}$ x 14GA           | 2        |
|      | HWL-12        | Lock Washer, $\frac{1}{2}$                      | 1        |
|      | HN-12-13      | Hex Nut, $\frac{1}{2}$ -13                      | 1        |
| 44   | 20-877        | Lower Cooler Mount                              | 1        |
|      | HB-516-18-075 | Hex Bolt, $\frac{3}{8}$ - 16 x $\frac{3}{4}$    | 4        |
|      | HNFL-516-18   | Flange Whiz-loc Nut, $\frac{3}{8}$ - 16         | 4        |

# SPRAY PUMP DRAWING

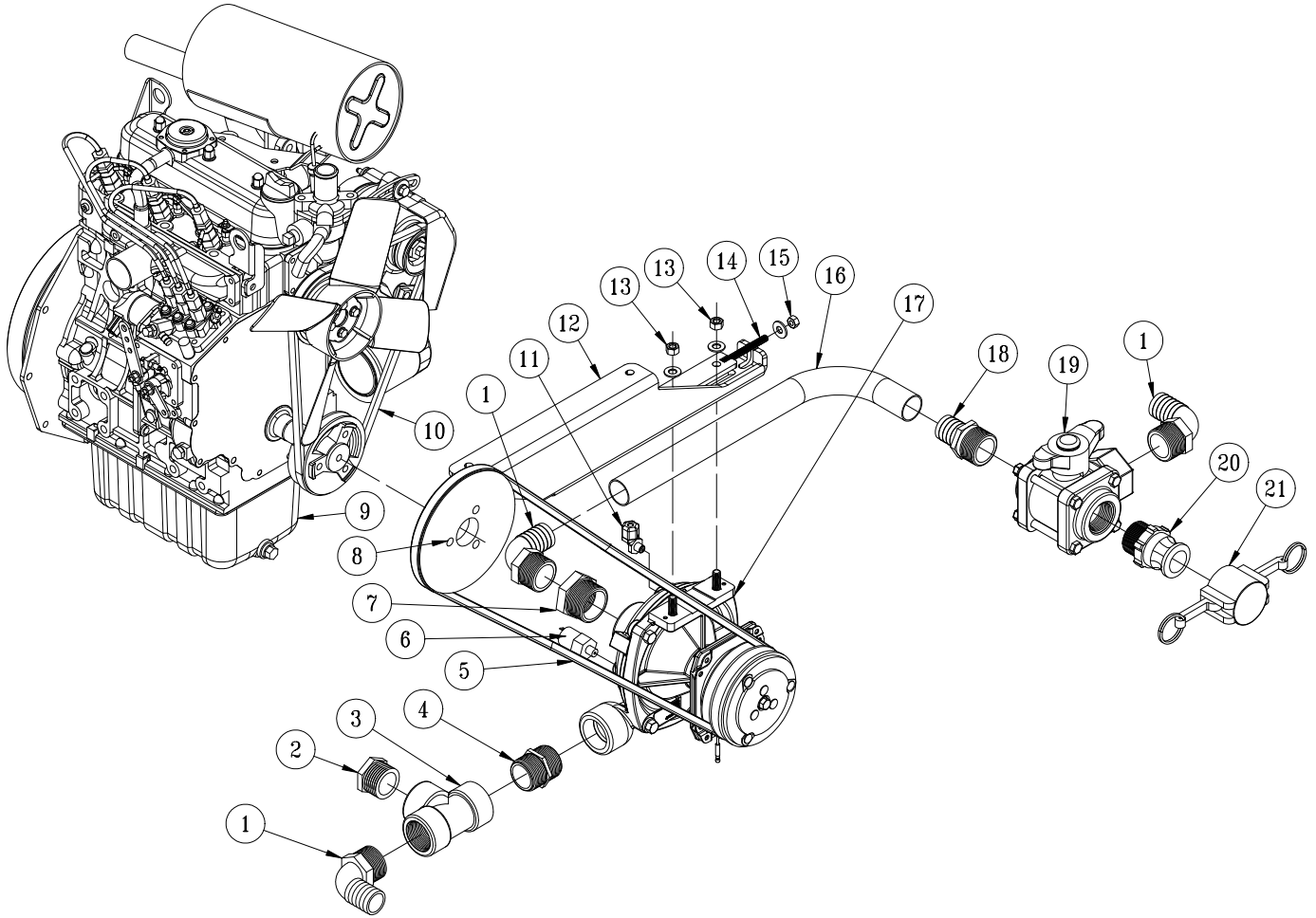

PARTS

## SPRAY PUMP PARTS LIST

| REF# | PART#        | DESCRIPTION                                   | QUANTITY |
|------|--------------|---|----------|
| 1    | 16-156       | Elbow   | 3        |
| 2    | 10-389       | Plug  | 1        |
| 3    | 18-390       | Tee   | 1        |
| 4    | 16-880       | Nipple  | 1        |
| 5    | 20-889       | Belt  | 1        |
| 6    | 33-480       | Pressure Switch                               | 1        |
| 7    | 16-825       | Hex Bushing                                   | 1        |
| 8    | 30-206       | Pulley  | 1        |
| 9    | 20-614       | 25 HP Kubota Diesel Engine                    | 1        |
| 10   | 30-042-11    | Fan Belt                                      | 1        |
| 11   | 18-475       | Male Elbow                                    | 1        |
| 12   | 20-885       | Pump Mount                                    | 1        |
| 13   | HB-38-16-150 | Hex Bolt, $\frac{3}{8}$ - 16 x $1\frac{1}{2}$ | 2        |
|      | HW-38        | Flat Washer, $\frac{3}{8}$                    | 2        |
|      | HNTL-38-16   | Nylon Lock Nut, $\frac{3}{8}$ - 16            | 2        |
| 14   | 8897         | Discharge Hose, $1\frac{1}{4}$ "              | 24"      |
|      | 18-222       | Hose Clamp                                    | 2        |
| 15   | 15-970       | Spray Pump                                    | 1        |
| 16   | 16-161       | Fitting                                       | 1        |
| 17   | 18-372       | 3-Way Valve                                   | 1        |
|      | 18-372-01    | T-Handle                                      | 1        |
| 18   | 16-180       | Quick Coupler Male                            | 1        |
| 19   | 16-935       | Quick Coupler Cap                             | 1        |

# SPRAY TANK DRAWING

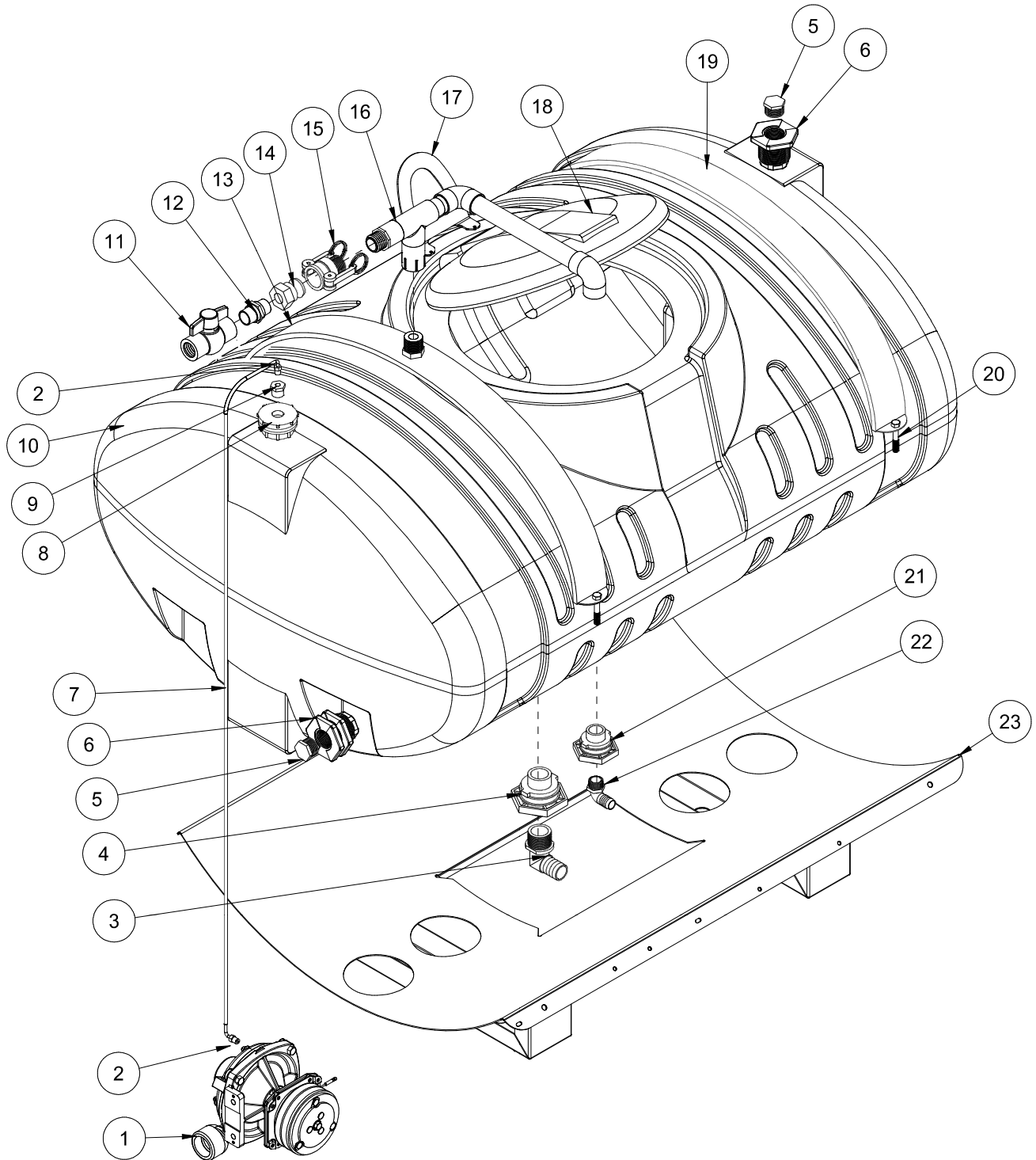

PARTS

## SPRAY TANK PARTS LIST

| REF# | PART#        | DESCRIPTION   | QUANTITY |
|------|--------------|---|----------|
| 1    | 15-970       | Hypro Pump  | 1        |
| 2    | 18-475       | Male Elbow  | 2        |
| 3    | 16-156       | Elbow   | 1        |
| 4    | 16-194       | 1 <sup>1</sup> / <sub>4</sub> Anti Vortex Fitting (part of tank)                | 1        |
| 5    | 16-162       | 1" Hex Plug   | 2        |
| 6    | 16-945       | 1" Double Thread Fitting  | 2        |
| 7    | 9038         | Tubing, 1 <sup>1</sup> / <sub>4</sub> "   | 46"      |
| 8    | 33-495       | Bulkhead Fitting  | 1        |
| 9    | 33-496       | Reducer Bushing, 1 <sup>1</sup> / <sub>2</sub> to 1 <sup>1</sup> / <sub>8</sub> | 1        |
| 10   | 20-802       | 200 Gallon Spray Tank   | 1        |
| 11   | 18-448       | 1" Ball Valve   | 1        |
| 12   | 16-851       | 1" Nipple   | 1        |
| 13   | 20-812       | Tank Strap with plug  | 1        |
| 14   | 16-961       | 1" Adapter  | 1        |
| 15   | 16-962       | 1" Coupler  | 1        |
|      | 16-962-01    | Buna-N Gasket (for 16-962)  | 1        |
| 16   | 15-964       | Air Gap Filler  | 1        |
| 17   | 10-639       | Lid Stop  | 1        |
| 18   | 16-953       | 16" Hinged Lid Well with Gasket   | 1        |
|      | 16-953-01    | Gasket (for Lid)  | 1        |
|      | 16-169       | Strainer Basket   | 1        |
| 19   | 20-811       | Tank Strap  | 1        |
| 20   | HB-38-16-250 | Hex Bolt, 3 <sup>3</sup> / <sub>8</sub> - 16 x 2 <sup>1</sup> / <sub>2</sub>    | 4        |
|      | HW-38        | Flat Washer, 3 <sup>3</sup> / <sub>8</sub>                                      | 8        |
|      | HNTL-38-16   | Nylon Lock Nut, 3 <sup>3</sup> / <sub>8</sub> - 16                              | 4        |
| 21   |              | 1 <sup>1</sup> / <sub>2</sub> " Double Thread Fitting (part of tank)            | 1        |
| 22   | 16-155       | Elbow   | 1        |
| 23   | 15-932       | Tank Carrier  | 1        |



# TURBO-QUAD AGITATOR DRAWING

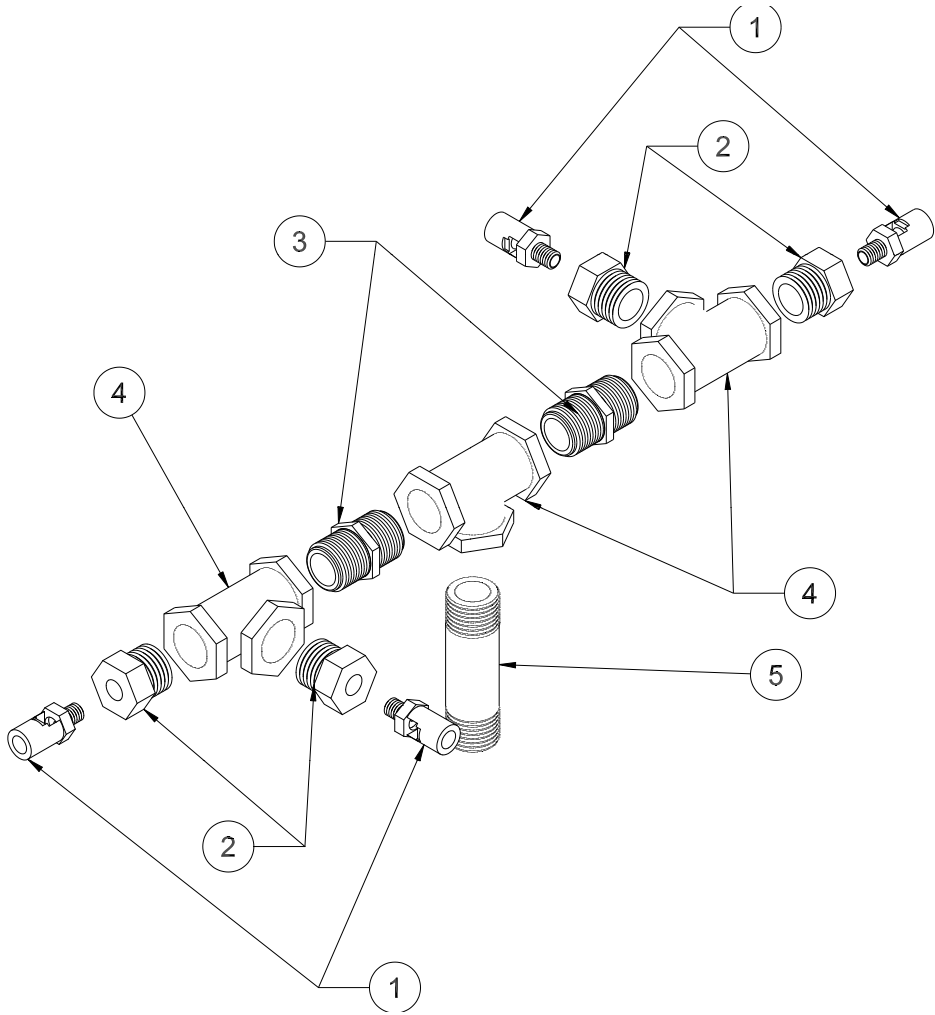

PARTS



## TURBO-QUAD AGITATOR PARTS LIST

| REF# | PART#  | DESCRIPTION   | QUANTITY |
|------|--------|---|----------|
| 1    | 18-510 | Mini Eductor  | 4        |
| 2    | 16-288 | Reducer, $\frac{3}{4}$ x $\frac{1}{4}$                                | 4        |
| 3    | 16-158 | Close Nipple, $\frac{3}{4}$ x $\frac{3}{4}$                           | 2        |
| 4    | 16-157 | Female Pipe Thread Tee, $\frac{3}{4}$ x $\frac{3}{4}$ x $\frac{3}{4}$ | 3        |
| 5    | 16-172 | Nylon Nipple, $\frac{3}{4}$ NPT x $3\frac{1}{2}$                      | 1        |

# PARK BRAKE AND REAR AXLE DRAWING

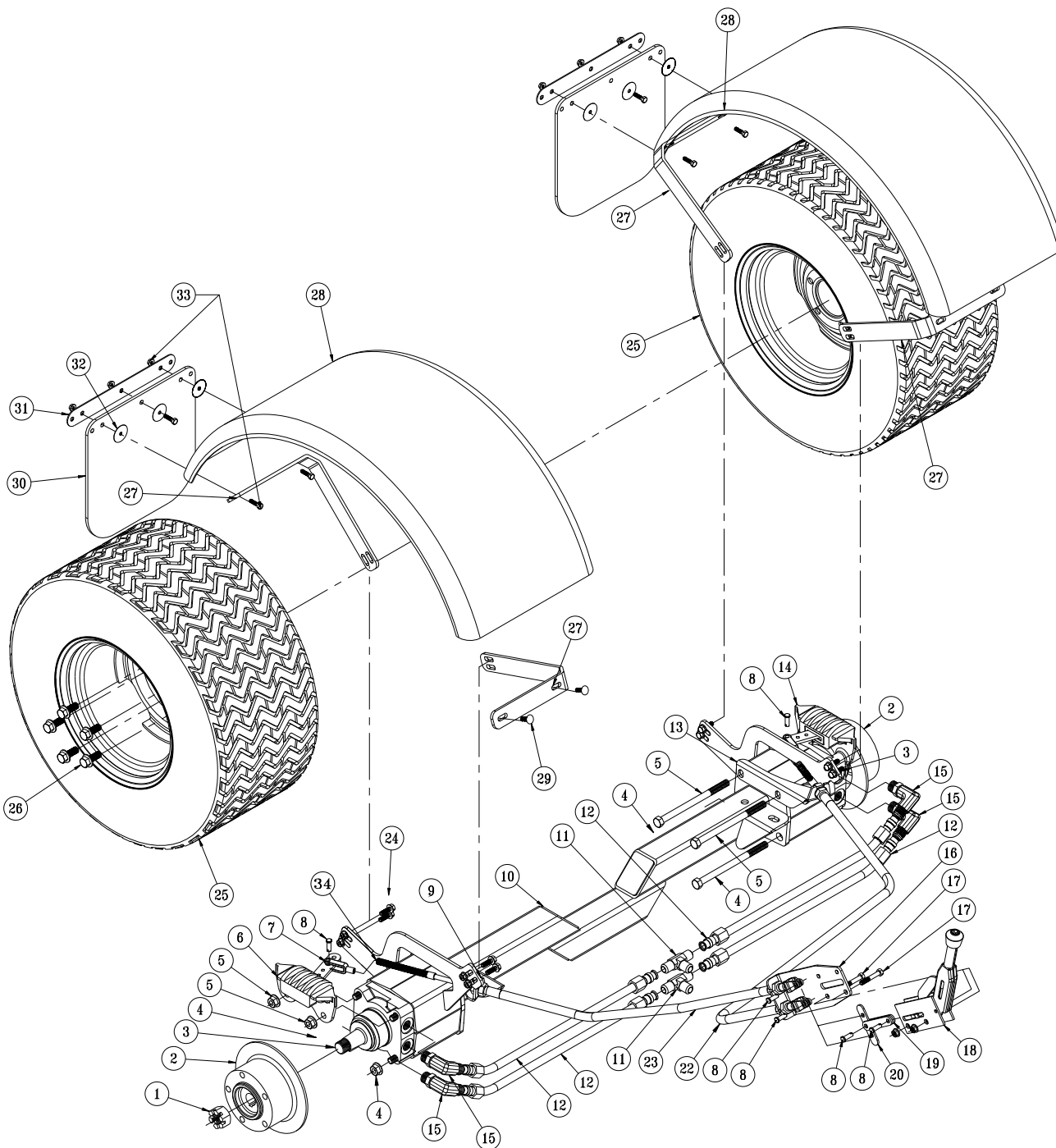

PARTS

## PARK BRAKE AND REAR AXLE PARTS LIST

| REF# | PART#           | DESCRIPTION   | QUANTITY |
|------|-----------------|---|----------|
| 1    | 14-265          | Lug Nut (comes with wheel motor)                          | 2        |
| 2    | 76-239          | Brake Disc, 5-hole  | 2        |
| 3    | 76-238          | Wheel Motor   | 2        |
|      | HMB-100-14      | Machine Bushing, 1 x 14GA                                 | 1        |
|      | HWK-516-100     | Woodruff Key, $\frac{5}{16}$ x 1 (comes with wheel motor) | 2        |
| 4    | HB-12-13-750    | Hex Bolt, $\frac{1}{2}$ - 13 x $7\frac{1}{2}$             | 4        |
|      | HNFL-12-13      | Flange Whiz-loc Nut, $\frac{1}{2}$ -13                    | 4        |
| 5    | HB-12-13-800    | Hex Bolt, $\frac{1}{2}$ - 13 x 8                          | 4        |
|      | HNFL-12-13      | Flange Whiz-loc Nut, $\frac{1}{2}$ - 13                   | 8        |
| 6    | 76-241          | Right Caliper CW  | 1        |
|      | 34-101-02       | Pad Kit   | 1        |
| 7    | 11-100          | Linkage Yoke, $\frac{5}{16}$ "                            | 2        |
|      | HN-516-24       | Hex Nut, $\frac{5}{16}$ - 24                              | 2        |
| 8    | HCP-516-100     | Clevis Pin, $\frac{5}{16}$ x 1                            | 6        |
|      | HP-18-075       | Cotter Pin, $\frac{1}{8}$ x $\frac{3}{4}$                 | 6        |
| 9    | 10-589          | RH Brake Cable Bracket                                    | 1        |
| 10   | 20-891          | Rear Axle   | 1        |
| 11   | 34-057          | Tee   | 2        |
| 12   | 20-656          | Hydraulic Tube  | 4        |
| 13   | 10-588          | LH Brake Cable Bracket                                    | 1        |
| 14   | 76-240          | Left Caliper CCW  | 1        |
|      | 34-101-02       | Pad Kit   | 1        |
| 15   | 34-122          | Short Elbow   | 4        |
| 16   | 15-942          | Cable Bracket   | 1        |
| 17   | HB-516-18-200   | Hex Bolt, $\frac{5}{16}$ -18 x 2                          | 2        |
|      | HNTL-516-18     | Lock Nut, $\frac{5}{16}$ - 18                             | 2        |
| 18   | 60-106          | Park Brake Lever Kit                                      | 1        |
| 19   | 45-074          | Park Brake Link   | 2        |
| 20   | 10-591          | Brake Equalizer   | 1        |
| 22   | 15-913          | LH Brake Cable  | 1        |
| 23   | 15-914          | RH Brake Cable  | 1        |
| 24   | HBFL-516-18-075 | Flange Whiz-loc Bolt, $\frac{5}{16}$ - 18 x $\frac{3}{4}$ | 8        |
|      | HNFL-516 - 18   | Flange Whiz-loc Nut, $\frac{5}{16}$ - 18                  | 8        |
| 25   | 16-225          | Rear Tire and Wheel                                       | 2        |
|      | 16-225-01       | Tire, 24 x 13.00 - 12NHS 4 Ply                            | 2        |
|      | 16-225-02       | Wheel   | 2        |
| 26   | 60-268          | Lug Bolt, $\frac{1}{2}$ -20 x $1\frac{5}{16}$             | 10       |
| 27   | 10-466          | Rear Fender Brackets                                      | 4        |
| 28   | 10-168          | Rear Fender   | 2        |
| 29   | HBC-516-18-100  | Carriage Hex Bolt, $\frac{5}{16}$ - 18 x 1                | 8        |
|      | HNFL-516-18     | Flange Whiz-loc Nut, $\frac{5}{16}$ - 18                  | 8        |
| 30   | 20-659          | Mud Flap  | 2        |
| 31   | 20-660          | Mud Flap Strap  | 2        |
| 32   | HWF-14-150      | Fender Washer, $\frac{1}{4}$ x $1\frac{1}{2}$             | 6        |
| 33   | HB-14-20-075    | Hex Bolt, $\frac{1}{4}$ - 20 x $\frac{3}{4}$              | 6        |
|      | HNFL-14-20      | Flange Whiz-loc Nut, $\frac{1}{4}$ - 20                   | 6        |
| 34   | 15-949          | Compression Spring  | 2        |
|      | HW-14           | Flat Washer, $\frac{1}{4}$                                | 2        |

# 15-301 ORBITROL DRAWING

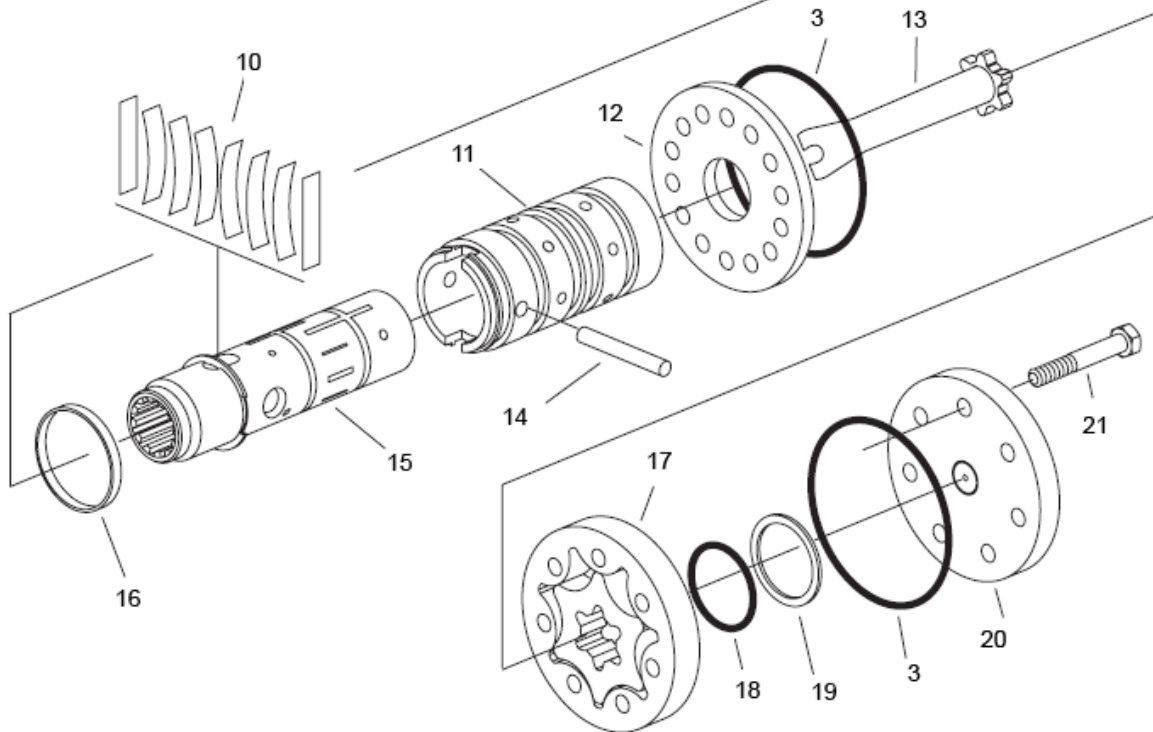
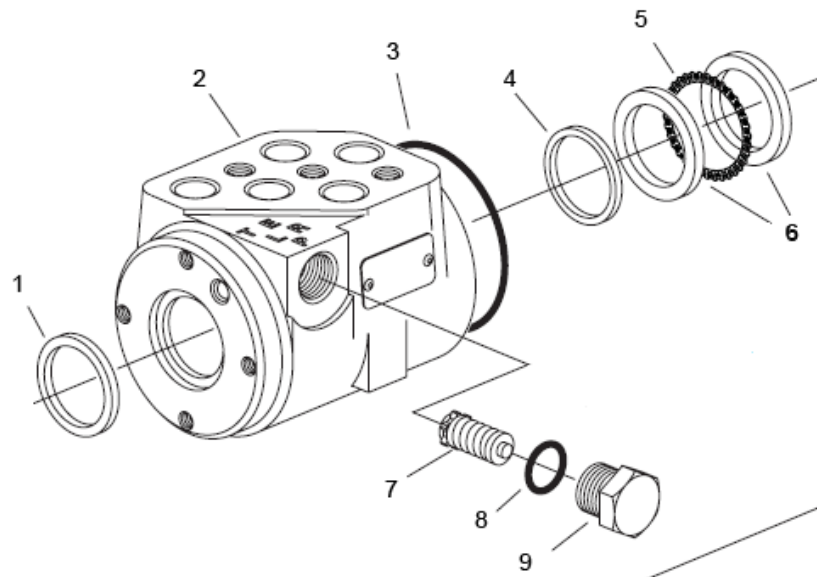

PARTS

# 15-301 ORBITROL PARTS LIST

| REF # | PART #    | DESCRIPTION                       | QUANTITY |
|-------|-----------|-----------------------------------|----------|
| 1**   | 10-576-04 | Dust Seal                         | 1        |
| 2     |           | Housing                           | 1        |
| 3**   |           | O-Ring Seal                       | 3        |
| 4**   |           | Quad Seal                         | 1        |
| 5     | 10-576-03 | Thrust Bearing                    | 1        |
| 6     | 10-576-02 | Bearing Race                      | 2        |
| 7     |           | Manual Steering Relief Valve      | 1        |
| 8**   |           | O-ring                            | 1        |
| 9     |           | Plug                              | 1        |
| 10‡   |           | Standard Torque Centering Springs | 1        |
| 11    |           | Sleeve                            | 1        |
| 12    | 15-301-06 | Wear Plate                        | 1        |
| 13    | 10-576-01 | Drive                             | 1        |
| 14    | 15-301-08 | Drive Pin                         | 1        |
| 15    |           | Spool                             | 1        |
| 16‡   |           | Spring Retaining Ring             | 1        |
| 17    | 10-576-05 | Gerotor                           | 1        |
| 18**  |           | O-Ring                            | 1        |
| 19**  |           | Seal Ring                         | 1        |
| 20    | 15-301-03 | End Cap                           | 1        |
| 21    | 10-576-06 | Cap Screw                         | 7        |
| **    | 15-301-01 | Seal Kit                          | 1        |
| ‡     | 15-301-15 | Centering Spring Kit              | 1        |

## 15-301 ORBITROL SPECIFICATIONS

|                                 |   |
|---------------------------------|---|
| Inlet Relief Valve Setting      | 1020 psi (70 bar)                             |
| Nominal Flow                    | 3 gpm (11 lpm)                                |
| Displacement                    | 4.50 cu. in/ R (73.8 cu cm/R)                 |
| Check Valve for Manual Steering | Yes   |
| Inlet Pressure Rating           | 2030 psi (140 bar)                            |
| Return Pressure Rating          | 145 psi (10 bar) Maximum                      |
| Fluid                           | SAE 10W-40 API Service SJ or higher Motor Oil |
| Ports                           | 9/16 - 18 SAE O-Ring 4 Ports                  |

# 76-638 HYDROSTATIC PUMP DRAWING

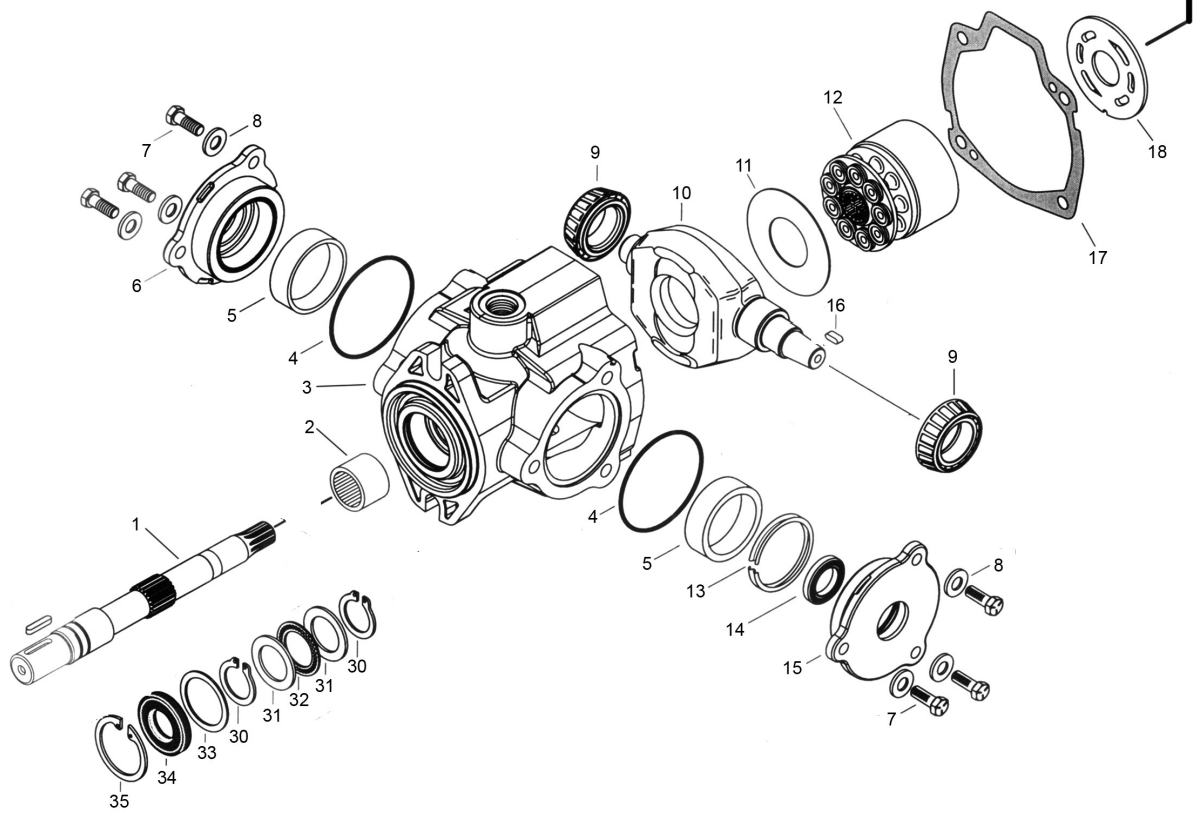
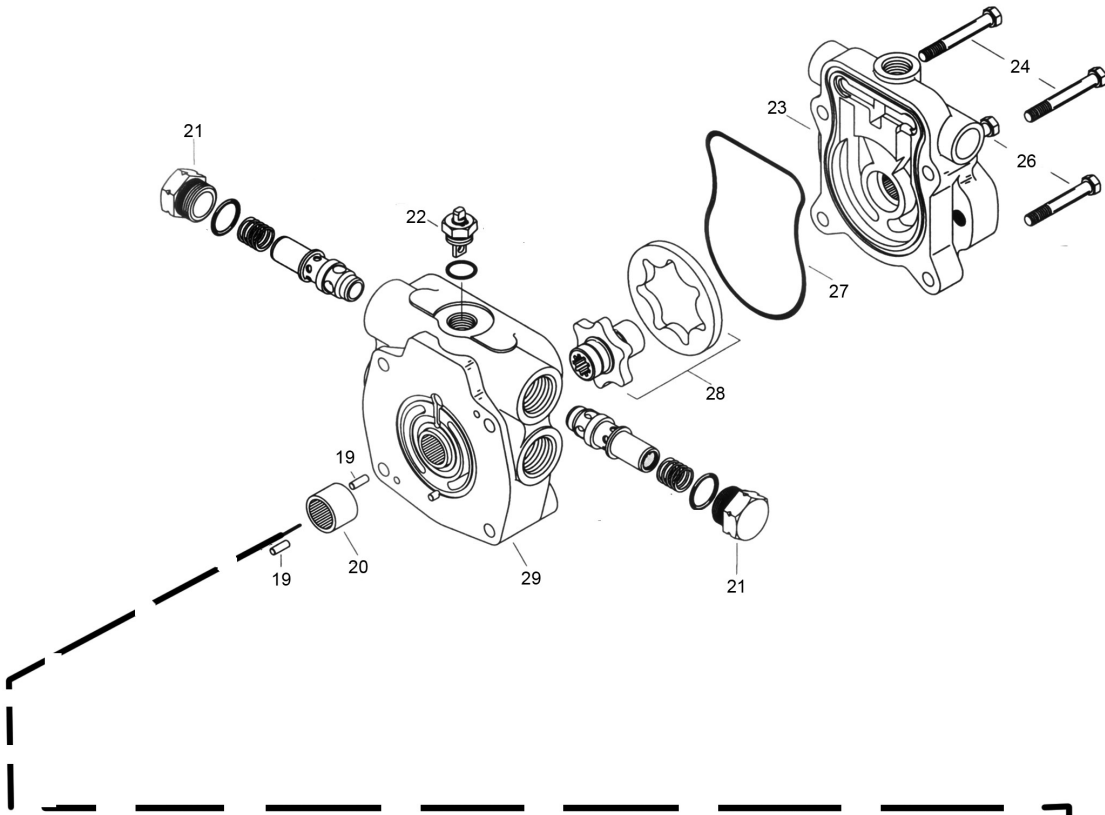

PARTS

## 76-638 HYDROSTATIC PUMP PARTS LIST

| REF#  | PART#     | DESCRIPTION                   | QUANTITY |
|-------|-----------|-------------------------------|----------|
| 1     | 76-398-01 | Drive Shaft (splined)         | 1        |
| 2     |           | Needle Bearing (with housing) | 1        |
| 3     | 77-239-01 | Housing                       | 1        |
| 4     | 77-239-02 | O-Ring                        | 1        |
| 5     | 77-239-03 | Thrust Bearing                | 2        |
| 6     | 77-239-04 | Trunnion Cover                | 1        |
| 7     | 77-239-05 | Pan Head Screw                | 2        |
| 8     | 77-239-06 | Washer                        | 6        |
| 9     | 77-239-07 | Cone Bearing                  | 2        |
| 10    | 77-239-08 | Swash Plate                   | 1        |
| 11    | 77-239-09 | Swash Plate Insert            | 1        |
| 12    | 60-343-21 | Rotating Kit                  | 1        |
| 13    | 77-239-10 | Crush Ring                    | 1        |
| 14*   | 60-343-12 | Shaft Seal                    | 1        |
| 15    | 77-239-11 | Seal Cover                    | 1        |
| 16    |           | Key                           | 1        |
| 17*   | 77-239-13 | Gasket                        | 1        |
| 18    | 76-482-01 | Back Plate                    | 1        |
| 19    |           | Dowel Pin                     | 2        |
| 20    |           | Bearing                       | 1        |
| 21    | 77-239-15 | Relief Valve                  | 2        |
| 22    | 77-239-16 | Tow Valve Assembly            | 1        |
| 23    |           | Charge Pump Adapter           | 1        |
| 24    | 77-239-17 | Cap Screw                     | 2        |
| 26    | 77-239-18 | Cap Screw                     | 2        |
| 27*   | 77-239-19 | O-Ring                        | 1        |
| 28    | 60-343-43 | Gerotor and Coupler           | 1        |
| 29    |           | End Cover Assembly            | 1        |
| 30*   | 77-239-21 | Retaining Ring                | 2        |
| 31    | 60-343-05 | Bearing Race                  | 1        |
| 32    | 60-343-06 | Thrust Bearing                | 1        |
| 33    | 60-343-03 | Washer                        | 2        |
| 34*   | 60-343-02 | Shaft Seal                    | 1        |
| 35*   | 60-343-01 | Retaining Ring                | 1        |
| *<br> | 77-239-23 | Seal Repair Kit               |          |

# 76-197 EATON GEAR PUMP DRAWING

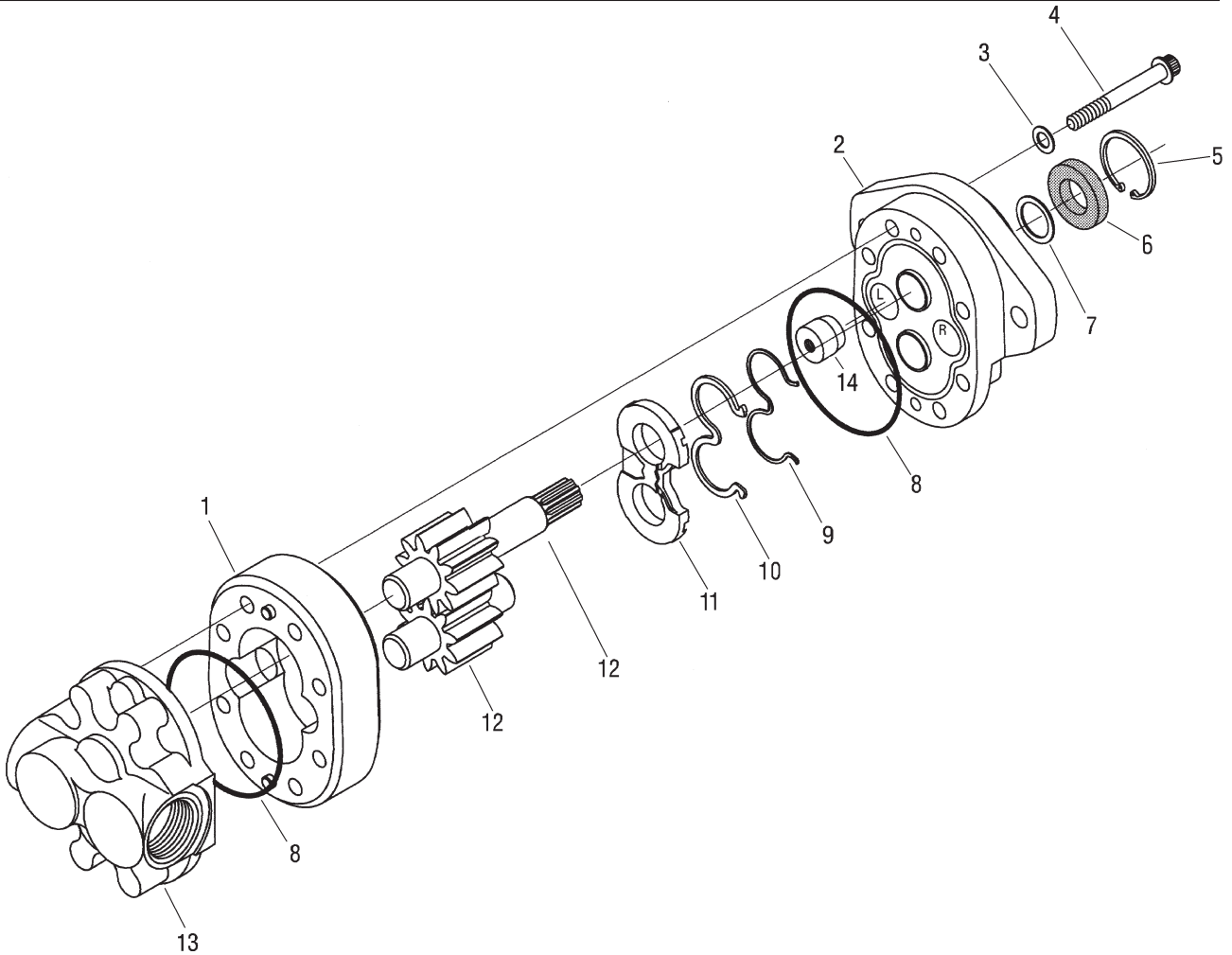

PARTS

| REF# | PART#     | DESCRIPTION                   | QUANTITY |
|------|-----------|-------------------------------|----------|
| 1    |           | Body                          | 1        |
| 2    | 76-197-01 | Front Plate                   | 1        |
| 3*   |           | Washer                        | 4        |
| 4    | 76-197-06 | Cap Screw                     | 8        |
| 5    | 76-197-07 | Retaining Ring                | 1        |
| 6*   |           | Shaft Seal                    | 1        |
| 7    | 33-061-15 | Washer                        | 1        |
| 8*   |           | O-Ring                        | 2        |
| 9*   |           | Backup Gasket                 | 1        |
| 10*  |           | Seal                          | 1        |
| 11*  |           | Wear Plate                    | 1        |
| 12   | 76-197-04 | Shaft (comes with Idler Gear) | 1        |
| 13   | 76-197-02 | Back Plate                    | 1        |
| 14*  |           | Plug                          | 1        |
| *    | 76-197-08 | Seal Kit                      |          |



# 76-238 REAR WHEEL MOTOR DRAWING (14.5 CI)

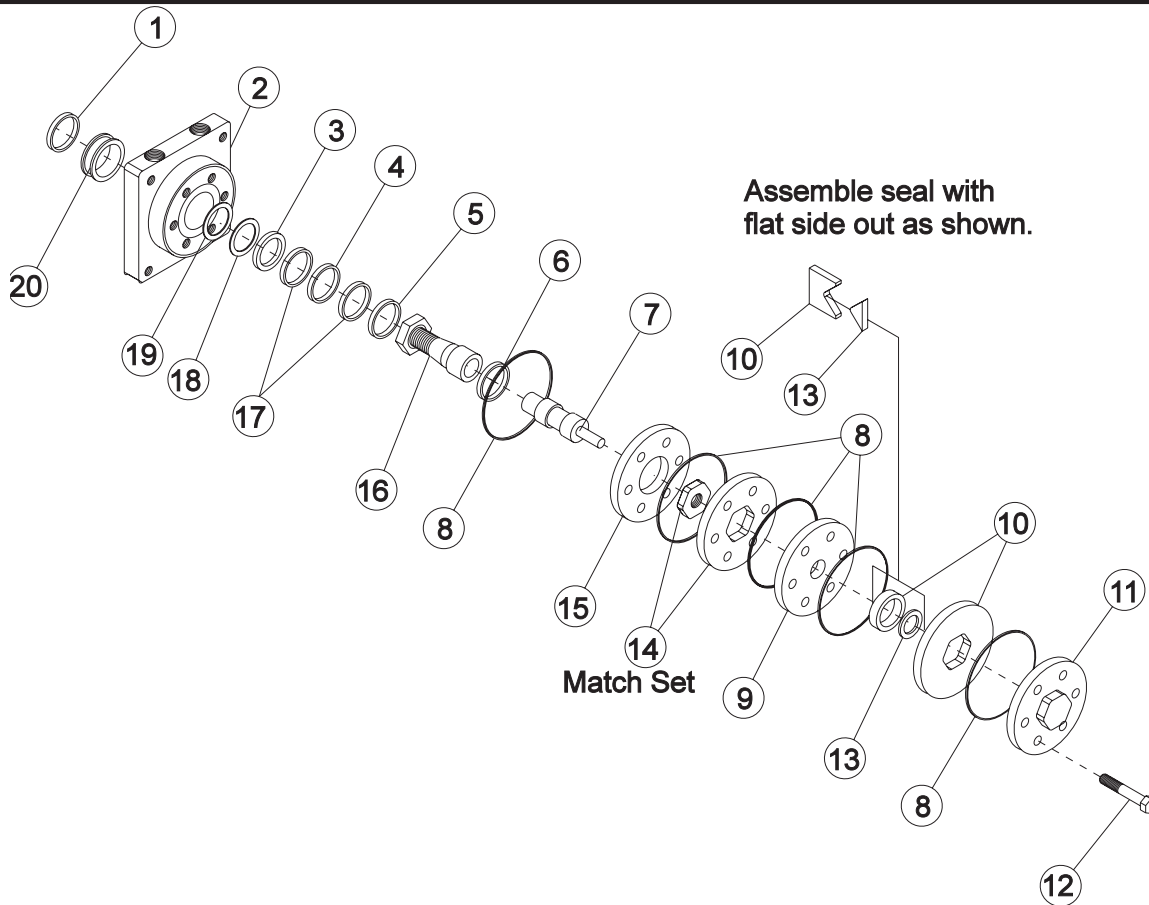

| REF# | PART#  | DESCRIPTION                           | QUANTITY |
|------|--|---------------------------------------|----------|
| 1*   |  | Water & Dirt Seal                     | 1        |
| 2†   | 13-615-05                                      | Service Housing Assembly              | 1        |
| 3*   |  | Inner Seal                            | 1        |
| 4†   | 13-032-27                                      | Thrust Bearing                        | 1        |
| 5†   | 13-032-28                                      | Inner Bearing                         | 1        |
| 6    | 13-032-29                                      | Thrust Bearing                        | 1        |
| 7    | 76-238-03                                      | Drive Link                            | 1        |
| 8*   |  | Ring Seal                             | 5        |
| 9    | 13-032-31                                      | Manifold                              | 1        |
| 10   | 13-032-32                                      | Commutator Assembly (matched set)     | 1        |
| 11   | 13-032-33                                      | End Cover                             | 1        |
| 12   | 76-238-01                                      | Hex Bolt                              | 7        |
| 13*  |  | Commutator Seal (matches with #10)    | 1        |
| 14   | 76-238-02                                      | Rotor Set (matched set)               | 1        |
| 15   | 13-032-35                                      | Plate Wear                            | 1        |
| 16   | 13-615-04                                      | Coupling Shaft                        | 1        |
|      | HWK-516-100                                    | Woodruff Key, $\frac{5}{16} \times 1$ | 1        |
|      | 14-265   | Nut, 1 - 20                           | 1        |
| 17†  | 13-032-37                                      | Thrust Washer                         | 2        |
| 18*  |  | Backup Washer                         | 1        |
| 19*  |  | Backup Washer                         | 1        |
| 20†  | 13-032-38                                      | Outer Bearing                         | 1        |
| *    | 14-080   | Seal Kit                              | 1        |
| †    | Included in 13-615-05 Service Housing Assembly |                                       |          |

# 15-970 HYPRO PUMP DRAWING

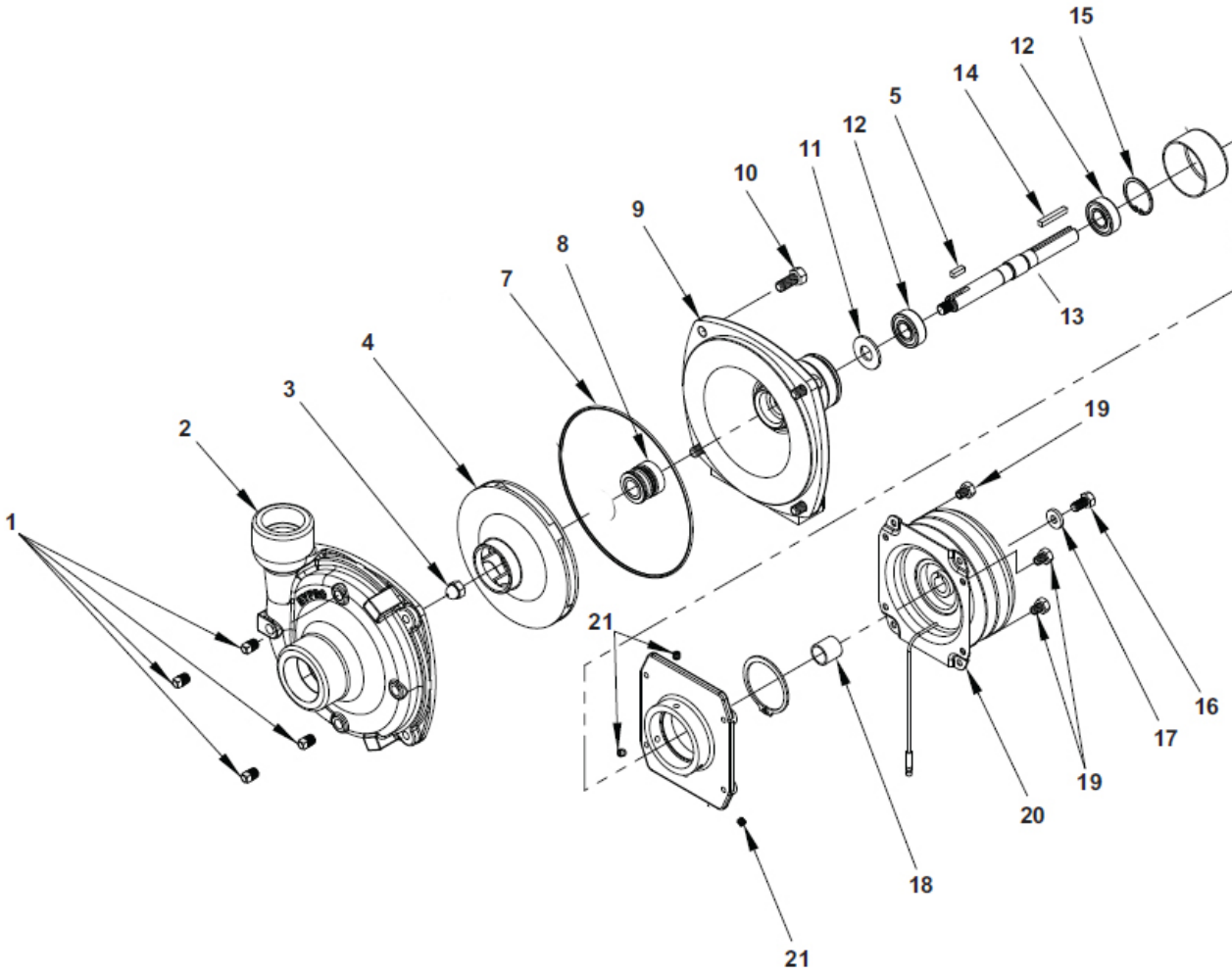

PARTS

# 15-970 HYPRO® PUMP PARTS LIST

| REF# | PART#     | DESCRIPTION                       | QUANTITY |
|------|-----------|-----------------------------------|----------|
| 1    | 16-998-01 | Drain Plug                        | 4        |
| 2    | 16-998-02 | Pump Casing                       | 1        |
| 3    | 16-998-03 | Impeller Nut                      | 1        |
| 4    | 16-966-16 | Impeller                          | 1        |
| 5    | 16-966-11 | Key                               | 1        |
| 7*   | 16-998-04 | O-Ring                            | 1        |
| 8*   | 16-967    | Mechanical Seal (Silicon Carbide) | 1        |
| 9    | 16-998-06 | Mounting Flange                   | 1        |
| 10   | 16-998-07 | Bolt                              |          |
| 11   | 16-966-06 | Slinger Ring                      | 1        |
| 12   | 16-966-10 | Ball Bearing                      | 2        |
| 13   | 16-966-12 | Pump Shaft                        | 1        |
| 14   | 16-822-20 | Key                               | 1        |
| 15   | 16-966-13 | Bearing Retainer                  | 1        |
| 16   | 16-994-05 | Bolt                              | 1        |
| 17   | 16-994-06 | Retaining Washer                  | 1        |
| 18   | 16-994-03 | Spacer                            | 1        |
| 19   |           | Bolt                              | 4        |
| 20   | 16-994-01 | Clutch                            | 1        |
| 21   | 16-994-04 | Set Screw                         | 3        |
|      | 16-998-12 | Pump Only                         |          |
| *    | 16-967    | Silicone - Carbon Seal Kit        |          |

**⚠ IMPORTANT**

When servicing the spray pump or filter, all control valves must be shut off if there is liquid in the tank.

# 20-684-P FLOW METER

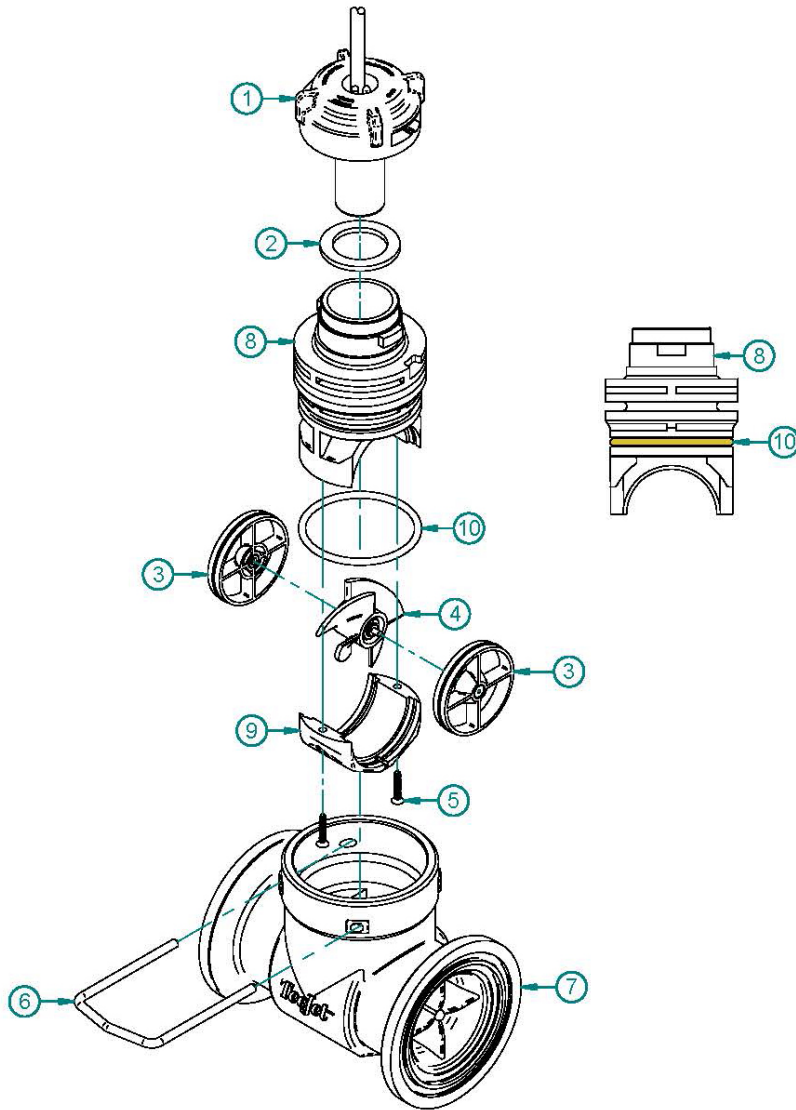

PARTS

| REF# | PART#     | DESCRIPTION                                      | QUANTITY |
|------|-----------|--|----------|
| 1    | 20-684-01 | Sensor, PCB Assembly                             | 1        |
| 2    |           | Washer, Seal                                     | 1        |
| 3*   |           | Guide Vane Bearing                               | 2        |
| 4*   |           | Turbine Assembly                                 | 1        |
| 5*   |           | Flat Head Screw, #6 - 5/8                        | 2        |
| 6    |           | Pin, Retaining                                   | 1        |
| 7    | 20-684-04 | Body   | 1        |
| 8*   |           | Insert, Body                                     | 1        |
| 9*   |           | End cap  | 1        |
| 10*  | 20-684-02 | Oring  | 1        |
| *    | 20-684-03 | 802 Flow-meter Repair Kit (includes all * items) |          |



# 1201D PLUMBING DRAWING (MANUAL SYSTEM)

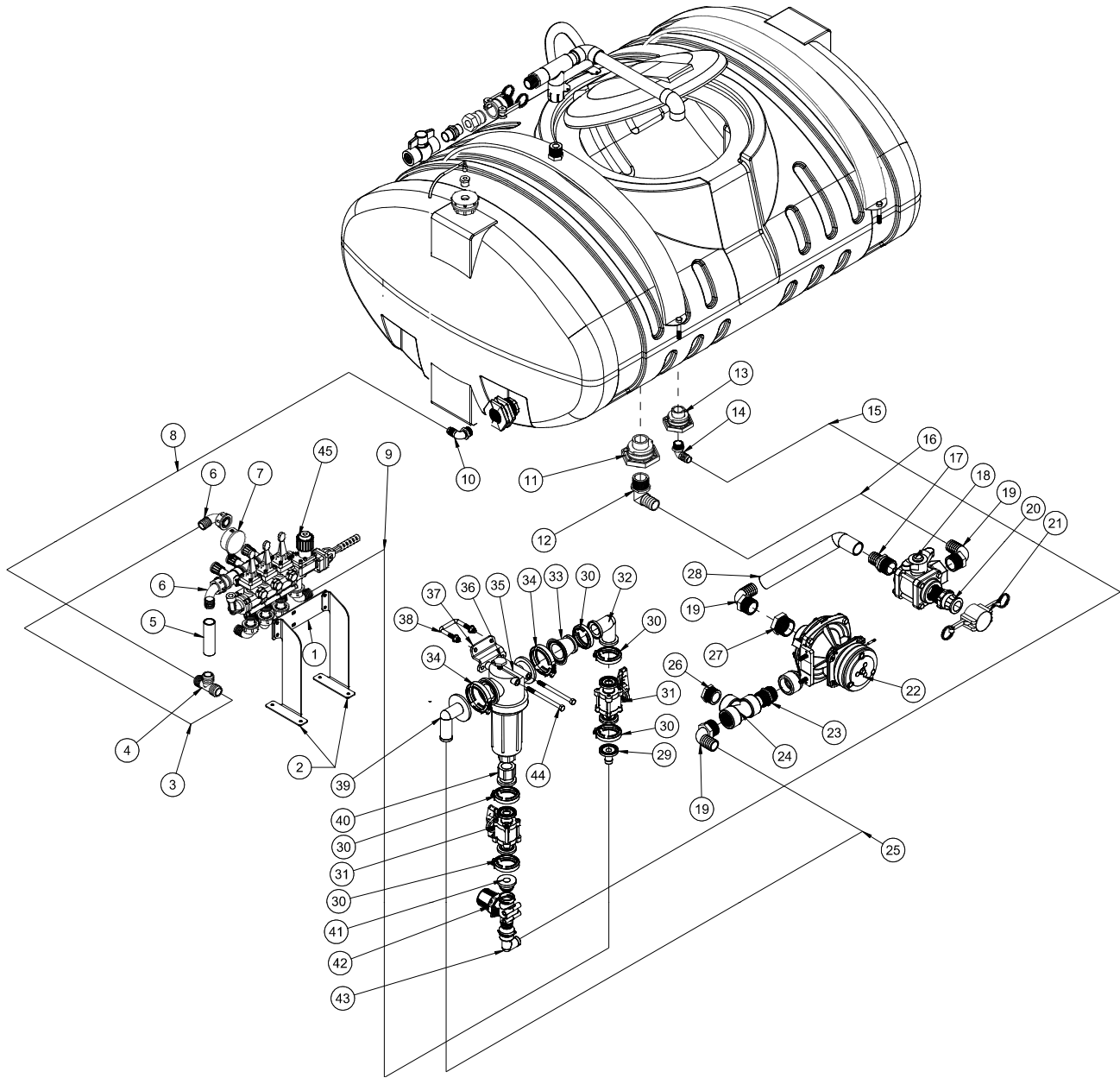

Accessories

| REF# | PART#     | DESCRIPTION                   | QUANTITY |
|------|-----------|-------------------------------|----------|
| 1    | 10-647    | Mount Plate                   | 1        |
| 2    | 10-646    | Ball Valve Mount Bracket      | 2        |
| 3    | 8896      | 1" Discharge Hose             | 12"      |
|      | 18-222    | Hose Clamp                    | 2        |
| 4    | 10-269    | Plastic Tee                   | 1        |
| 5    | 8896      | 1" Discharge Hose             | 4"       |
|      | 18-222    | Hose Clamp                    | 2        |
| 6    | 10-268-13 | 90° Elbow (comes with 10-648) | 3        |
|      | 18-040    | Hose Clamp                    | 6        |
| 7    | 16-281    | Liquid Filled Gauge           | 1        |
| 8    | 8896      | Discharge Hose 1"             | 22"      |
|      | 18-222    | Hose Clamp                    | 2        |
| 9    | 8896      | Discharge Hose 1"             | 40"      |
|      | 18-222    | Hose Clamp                    | 2        |
| 10   | 16-153    | Elbow                         | 1        |

# 1201D PLUMBING DRAWING (MANUAL SYSTEM)

| REF# | PART#        | DESCRIPTION                               | QUANTITY |
|------|--------------|---|----------|
| 11   | 16-194       | Anti-Vortex Fitting                       | 1        |
| 12   | 16-156       | Elbow                                     | 1        |
| 13   |              | 1/2" Double Thread Fitting (part of tank) | 1        |
| 14   | 16-155       | Elbow                                     | 1        |
| 15   | 8896         | Discharge Hose 1"                         | 56"      |
|      | 18-222       | Hose Clamp                                | 2        |
| 16   | 8897         | Discharge Hose 1 1/4"                     | 26"      |
|      | 18-116       | Hose Clamp                                | 2        |
| 17   | 16-161       | Fitting 1 1/4 NPT x 1 1/4 HB              | 2        |
| 18   | 18-372       | 3-Way Ball Valve                          | 1        |
|      | 18-372-01    | T-Handle                                  | 1        |
| 19   | 16-156       | Elbow 1 1/4 MPT x 1 1/4 HB                | 3        |
| 20   | 16-180       | Quick Coupler 1 1/4 Male                  | 1        |
| 21   | 16-935       | Quick Coupler 1 1/4 Cap                   | 1        |
| 22   | 15-970       | Hypro® Pump                               | 1        |
| 23   | 16-880       | Nipple                                    | 1        |
| 24   | 18-390       | Pipe Tee 1 1/4                            | 1        |
| 25   | 8897         | Discharge Hose 1 1/4"                     | 57"      |
|      | 18-116       | Hose Clamp, HS-24                         | 2        |
| 26   | 10-389       | Plug 1 1/4                                | 1        |
| 27   | 16-825       | Reducer                                   | 1        |
| 28   | 8897         | Discharge Hose 1 1/4                      | 24"      |
|      | 18-116       | Hose Clamp                                | 2        |
| 29   | 15-808       | Hose Barb Flange                          | 1        |
| 30   | 15-740       | 50 Series Clamp                           | 5        |
| 31   | 15-738       | Flanged Ball Valve                        | 2        |
| 32   | 15-736       | 50 Series Elbow Coupling                  | 1        |
| 33   | 15-748       | Reducer Coupling                          | 1        |
| 34   | 15-741       | 75 Series Clamp                           | 2        |
| 35   | 15-737       | Flanged Strainer                          | 1        |
| 36   | 15-780       | 1/4" Poly Plug                            | 1        |
| 37   | 30-551       | Filter Mount                              | 1        |
| 38   | 17-537       | U-Bolt                                    | 1        |
| 39   | 15-739       | 75 Series 90° x 1 1/4 Hose Barb           | 1        |
| 40   | 15-735       | 50 Series 1 FPT                           | 1        |
| 41   | 15-825       | QC Flange Adapter                         | 1        |
| 42   | 14-801       | Agitation Strainer, 50 mesh               | 1        |
|      | 14-802       | 50 Mesh Screen                            |          |
|      | 14-803       | Decal, Clean Strainer                     | 1        |
| 43   | 14-671       | 90° - 1" Hose Barb                        | 1        |
| 44   | HB-38-16-500 | Bolt, 3/8 - 16 x 5                        | 2        |
|      | HNFL-38-16   | Flange Lock Nut, 3/8 - 16                 | 2        |
| 45   | 10-648       | Valve 3-Way                               | 1        |

| <u>BOOM</u> | <u>LEFT HOSE</u> | <u>CENTER HOSE</u> | <u>RIGHT HOSE</u> |
|-------------|------------------|--------------------|-------------------|
| 15"         | 9032-153         | 9032-114           | 9032-153          |
| 18'         | 9032-153         | 9032-114           | 9032-153          |

# 1202D PLUMBING DRAWING (RADION® 8140)

15-818 #75 Fitting Oring

15-817 #50 Fitting Oring

| BOOM | LEFT HOSE | CENTER HOSE | RIGHT HOSE |
|------|-----------|-------------|------------|
| 15"  | 9032-125  | 9032-90     | 9032-136   |
| 18'  | 9032-125  | 9032-90     | 9032-136   |
| 20'  | 9032-135  | 9032-90     | 9032-146   |

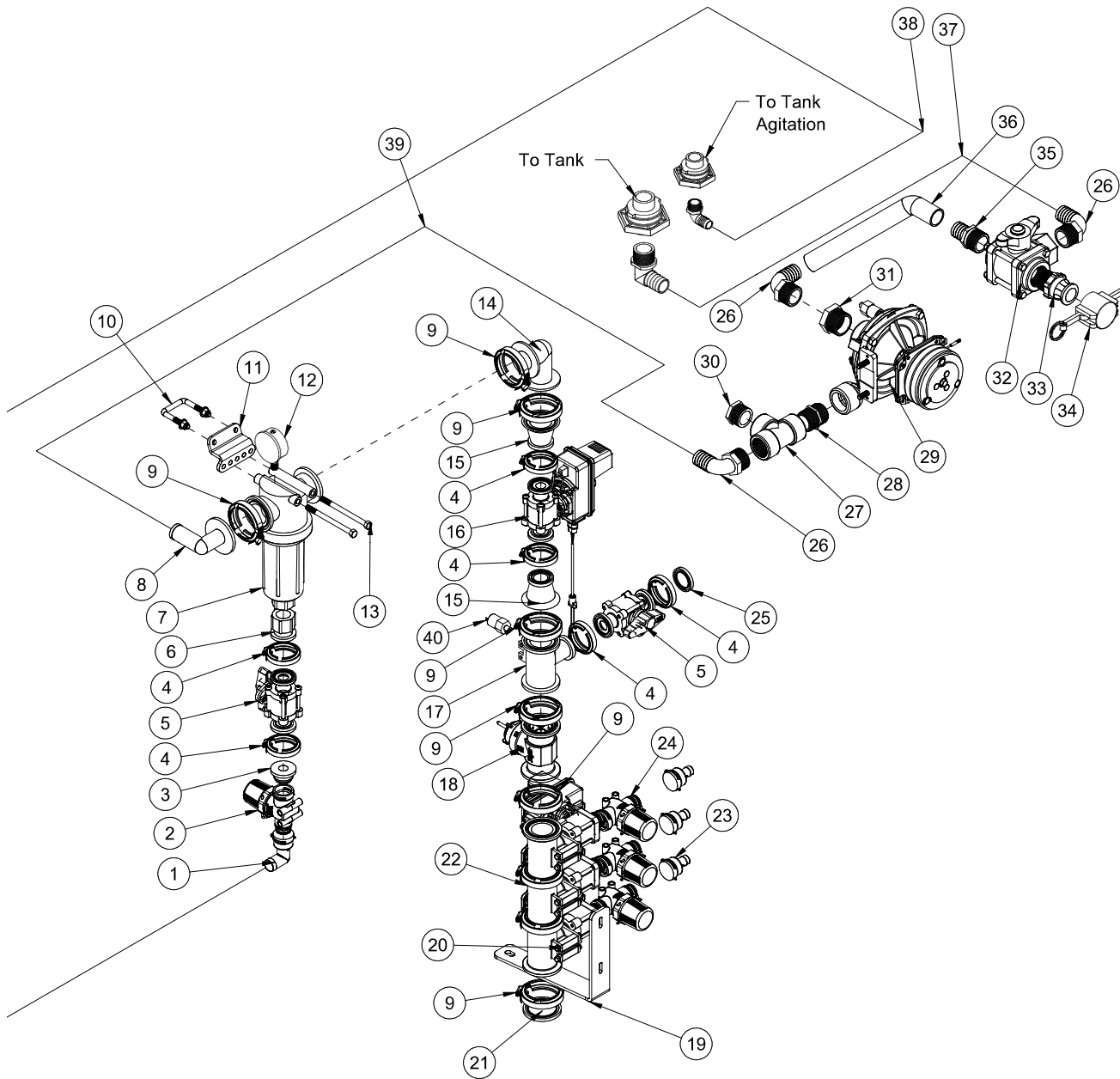

**▲ IMPORTANT**

If using Simulated Speed with a Radion 8140, one needs to change back to Ground Speed for proper rate control when spraying.



# 1202D PLUMBING PARTS LIST (RADION® 81401)

| REF# | PART#        | DESCRIPTION                     | QUANTITY |
|------|--------------|---------------------------------|----------|
| 1    | 14-671       | Elbow                           | 1        |
| 2    | 14-801       | Agitator Line Strainer, 50 Mesh | 1        |
|      | 14-802       | Replacement 50 Mesh Screen      |          |
|      | 14-803       | Decal, Clean Strainer           | 1        |
| 3    | 15-825       | #50 Male Quick Coupler          | 1        |
| 4    | 15-740       | #50 Series Clamp                | 6        |
| 5    | 15-738       | Flanged Ball Valve              | 2        |
| 6    | 15-735       | #50 x 1 FTP Fitting             | 1        |
| 7    | 15-737       | Flanged Strainer                | 1        |
|      | 16-968-03    | Screen (50 mesh)                | 1        |
| 8    | 15-739       | #75 90° Hose Barb               | 1        |
| 9    | 15-741       | #75 Series Clamp                | 7        |
| 10   | 17-537       | Square U-bolt                   | 1        |
| 11   | 30-551       | Filter Mount                    | 1        |
| 12   | 16-281       | Liquid Filled Gauge             | 1        |
| 13   | HB-38-16-500 | Hex Bolt, 3/8 - 16 x 5          | 2        |
|      | HNFL-38-16   | Flange Whiz-loc Nut, 3/8 - 16   | 2        |
| 14   | 15-734       | #75 Elbow Coupling              | 1        |
| 15   | 15-748       | Reducer Coupling (#75 to #50)   | 2        |
| 16   | 20-785       | Regulator Valve                 | 1        |
| 17   | 30-164       | Tapped Reducer Tee              | 1        |
| 18   | 20-684       | #802 Flow Meter                 | 1        |
| 19   | 20-887       | Lower Brace                     | 1        |
| 20   | 15-743-03    | Mounting Rail                   | 2        |
|      | 15-743-06    | Screw, SS                       | 8        |
| 21   | 15-742       | #75 Inlet Cover                 | 1        |
| 22   | 15-743       | Manifold Valve                  | 1        |
| 23   | 14-660       | 3/4 Quick Connect Hose Barb     | 3        |
| 24   | 14-607       | Strainer, QC 100 Mesh           | 3        |
| 25   | 15-778       | Blank Gauge Port Flange         | 1        |
| 26   | 16-156       | Elbow                           | 3        |
| 27   | 18-390       | Tee                             | 1        |
| 28   | 16-880       | Nipple                          | 1        |
| 29   | 15-970       | Pump                            | 1        |
| 30   | 10-389       | Plug                            | 1        |
| 31   | 16-825       | Hex Bushing                     | 1        |
| 32   | 18-372       | 3-Way Valve                     | 1        |
|      | 18-372-01    | T-Handle                        | 1        |
| 33   | 16-180       | Quick Coupler Male              | 1        |
| 34   | 16-935       | Quick Coupler Cap               | 1        |
| 35   | 16-161       | Fitting                         | 2        |
| 36   | 8897         | 1 1/4" Discharge Hose           | 24"      |
|      | 18-116       | Hose Clamp                      | 2        |
| 37   | 8897         | 1 1/4" Discharge Hose           | 26"      |
|      | 18-116       | Hose Clamp                      | 2        |
| 38   | 8896         | 1" Suction Hose                 | 56"      |
|      | 18-222       | Hose Clamp                      | 2        |
| 39   | 8897         | 1 1/4" Discharge Hose           | 57"      |
|      | 18-116       | Hose Clamp                      | 2        |
| 40   | 20-670-04    | Radion Pressure Sensor          | 1        |

# 1204D PLUMBING DRAWING (TEEJET® 744)

15-818 #75 Fitting Oring  
 15-817 #50 Fitting Oring

| BOOM | LEFT HOSE | CENTER HOSE | RIGHT HOSE |
|------|-----------|-------------|------------|
| 15"  | 9032-125  | 9032-90     | 9032-136   |
| 18'  | 9032-125  | 9032-90     | 9032-136   |
| 20'  | 9032-135  | 9032-90     | 9032-146   |

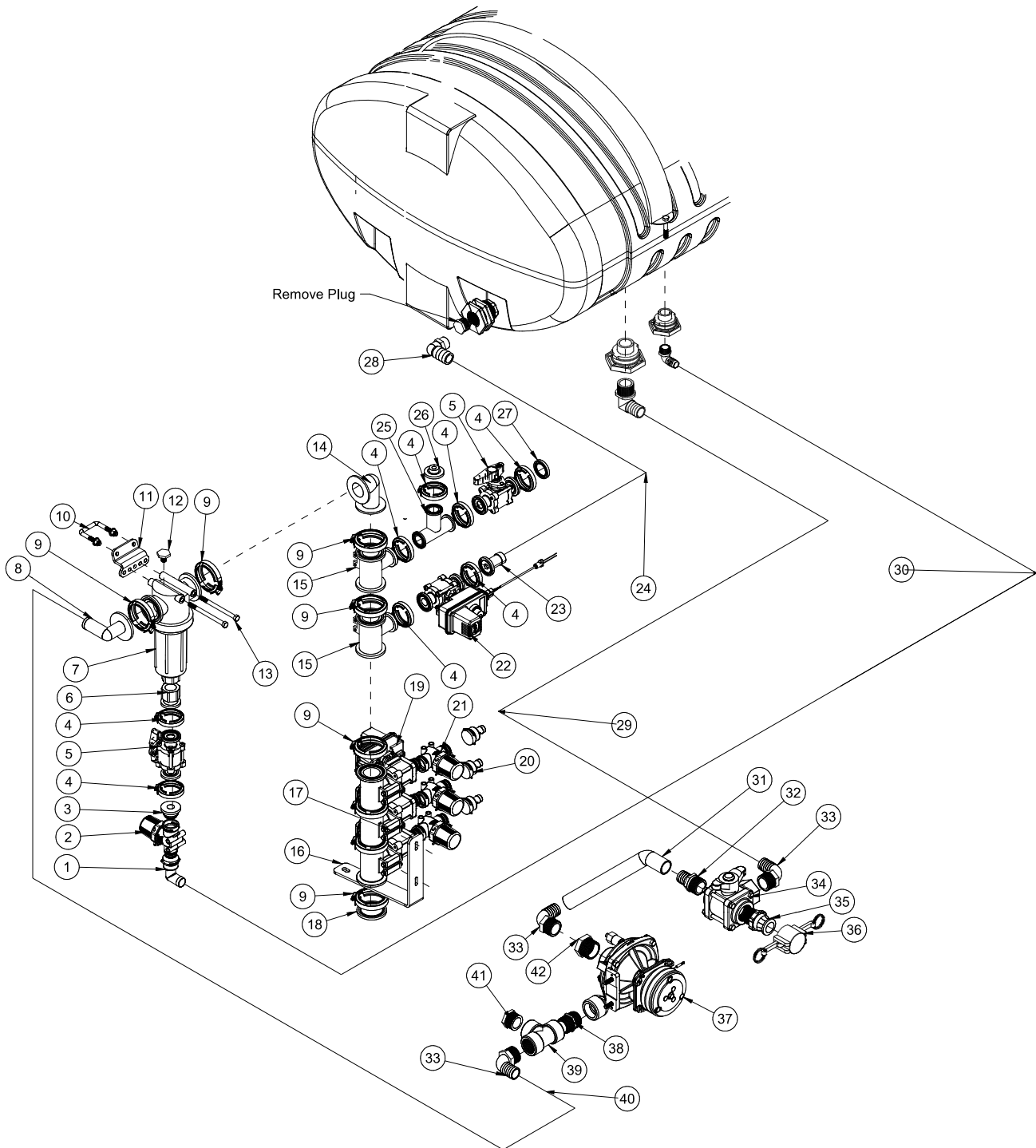

Accessories

## 1204D PLUMBING PARTS LIST (TEEJET® 744)

| REF# | PART#        | DESCRIPTION                     | QUANTITY |
|------|--------------|---------------------------------|----------|
| 1    | 14-671       | Elbow                           | 1        |
| 2    | 14-801       | Agitator Line Strainer, 50 Mesh | 1        |
|      | 14-802       | Replacement 50 Mesh Screen      |          |
|      | 14-803       | Decal, Clean Strainer           | 1        |
| 3    | 15-825       | #50 Male Quick Coupler          | 1        |
| 4    | 15-740       | #50 Series Clamp                | 8        |
| 5    | 15-738       | Flanged Ball Valve              | 2        |
| 6    | 15-735       | #50 x 1 FTP Fitting             | 1        |
| 7    | 15-737       | Flanged Strainer                | 1        |
|      | 16-968-03    | Screen (50 mesh)                | 1        |
| 8    | 15-739       | #75 90° Hose Barb               | 1        |
| 9    | 15-741       | #75 Series Clamp                | 6        |
| 10   | 17-537       | Square U-bolt                   | 1        |
| 11   | 30-551       | Filter Mount                    | 1        |
| 12   | 15-780       | Poly Hex Plug                   | 1        |
| 13   | HB-38-16-500 | Hex Bolt, 3/8 - 16 x 5          | 2        |
|      | HNFL-38-16   | Flange Whiz-loc Nut, 3/8 - 16   | 2        |
| 14   | 15-734       | #75 Elbow Coupling              | 1        |
| 15   | 15-775       | Reducer Tee                     | 2        |
| 16   | 20-893       | Lower Valve Bracket             | 1        |
| 17   | 15-743-03    | Mounting Rail                   | 2        |
|      | 15-743-06    | Screw, SS                       | 8        |
| 18   | 15-742       | #75 Inlet Cover                 | 1        |
| 19   | 15-743       | Manifold Ball Valve             | 1        |
| 20   | 14-660       | 3/4 Quick Connect Hose Barb     | 3        |
| 21   | 14-607       | Strainer, QC 100 Mesh           | 3        |
| 22   | 20-817       | Regulating Valve                | 1        |
| 23   | 15-870       | #50 1 1/4 Hose Barb             | 1        |
| 24   | 8897         | 1 1/4" Discharge Hose           | 30"      |
|      | 18-116       | Hose Clamp                      | 2        |
| 25   | 15-776       | #50 Tee                         | 1        |
| 26   | 15-777       | Gauge Port Flange               | 1        |
| 27   | 15-778       | Blank Gauge Port Flange         | 1        |
| 28   | 15-779       | Hose Barb (remove plug)         | 1        |
| 29   | 8897         | 1 1/4" Discharge Hose           | 26"      |
|      | 18-116       | Hose Clamp                      | 2        |
| 30   | 8896         | 1" Suction Hose                 | 56"      |
|      | 18-220       | Hose Clamp                      | 2        |
| 31   | 8897         | 1 1/4" Discharge Hose           | 24"      |
|      | 18-116       | Hose Clamp                      | 2        |
| 32   | 16-161       | Fitting                         | 1        |
| 33   | 16-156       | Elbow                           | 3        |
| 34   | 18-372       | 3-Way Valve                     | 1        |
|      | 18-372-01    | T-Handle                        | 1        |
| 35   | 16-180       | Quick Coupler Male              | 1        |
| 36   | 16-935       | Quick Coupler Cap               | 1        |
| 37   | 15-970       | Pump                            | 1        |
| 38   | 16-880       | Nipple                          | 1        |
| 39   | 18-390       | Tee                             | 1        |
| 40   | 8897-57      | 1 1/4" Discharge Hose           | 57"      |
|      | 18-116       | Hose Clamp                      | 2        |
| 41   | 10-389       | Plug                            | 1        |
| 42   | 16-825       | Hex Bushing                     | 1        |

# 1202D SYSTEM WIRING (RADION® 8140)

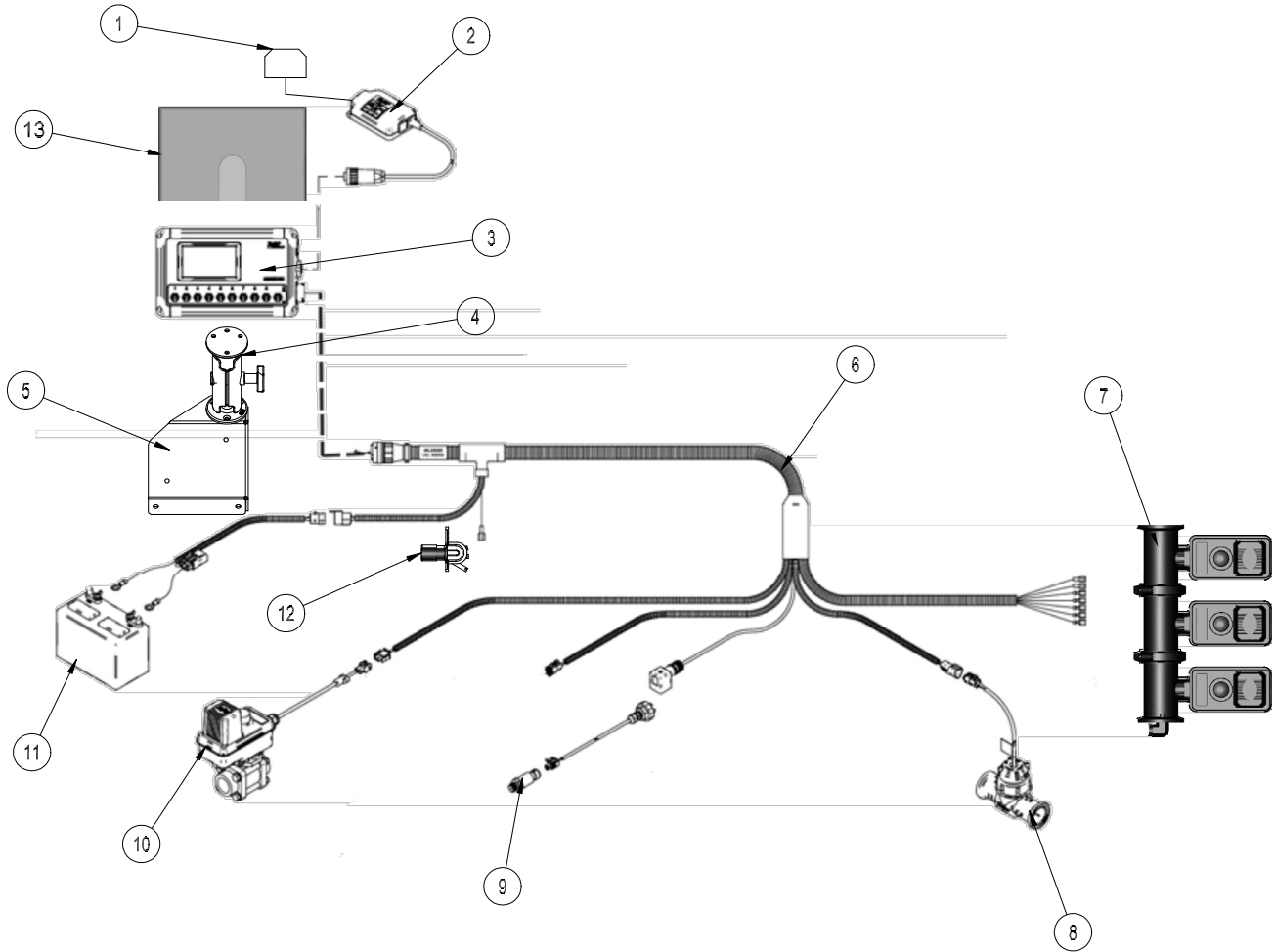

**⚠ IMPORTANT**

If using Simulated Speed with a Radion 8140, one needs to change back to Ground Speed for proper rate control when spraying.

Accessories

| REF# | PART#     | DESCRIPTION                           | QUANTITY |
|------|-----------|---------------------------------------|----------|
| 1*   |           | Antenna                               | 1        |
| 2*   | 20-687-02 | GPS Speed Sensor                      | 1        |
| 3*   | 20-697-01 | Radion 8140 Console                   | 1        |
| 4    | 20-540    | Ram Mount                             | 1        |
| 5    | 10-721    | Mount Bracket                         | 1        |
| 6*   |           | Wire Harness                          | 1        |
| 7    | 15-743    | Manifold Valve                        | 1        |
| 8    | 20-684    | Flow Meter                            | 1        |
| 9*   | 20-670-04 | Pressure Sensor                       | 1        |
| 10   | 20-785    | Regulator Valve                       | 1        |
| 11   | 33-216    | Battery                               | 1        |
| 12   | 33-509    | Master Boom Control                   | 1        |
| 13   | 20-781    | Radion Console Cover                  | 1        |
| *    | 20-697    | TeeJet® Radion Kit (includes * items) | 1        |
| NS   | 33-508    | Auto Blade Fuse 15AMP                 | 1        |
| NS   | 33-562    | Auto Blade Fuse 40AMP                 | 1        |

# 1204D SYSTEM WIRING (TEEJET 744®)

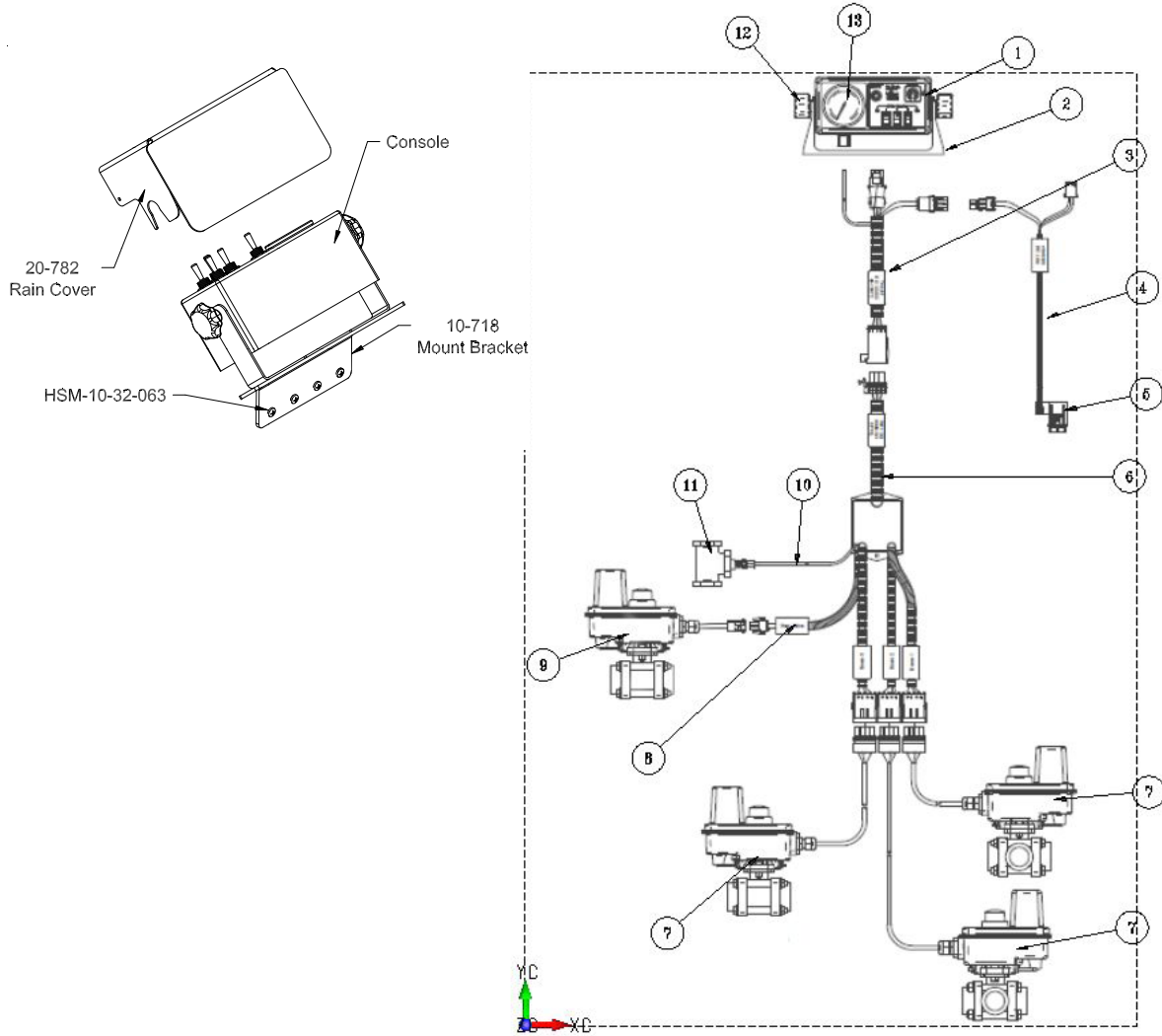

| REF# | PART#     | DESCRIPTION             | QUANTITY |
|------|-----------|-------------------------|----------|
| 1*   | 20-688-02 | 744A Console            | 1        |
|      | 20-688-01 | 200PSI Gauge            | 1        |
|      | 20-688-07 | Circuit Board           | 1        |
|      | 20-688-08 | Gauge Elbow             | 1        |
| 2    | 10-718    | Mount Bracket           | 1        |
| 3*   |           | Console harness         | 1        |
| 4*   |           | Fused Power Cable       | 1        |
| 5    | 33-271    | Fuse Block              | 1        |
| 6*   |           | Ball Valve Wire Harness | 1        |
| 7    | 15-743    | Manifold Ball Valve     | 1        |
| 8*   |           | Regulator Valve Adapter | 1        |
| 9    | 20-817    | Regulating Valve        | 1        |
| 10*  | 20-688-04 | Tubing                  | 1        |
|      | 15-776    | Tee                     | 1        |
| 12*  | 20-688-09 | Mounting Knob           | 2        |
| 13*  | 20-688-01 | PSI Liquid Gauge        | 1        |

\* 20-688 744A Kit Complete (includes \* items)

# CONTROL MOUNTS

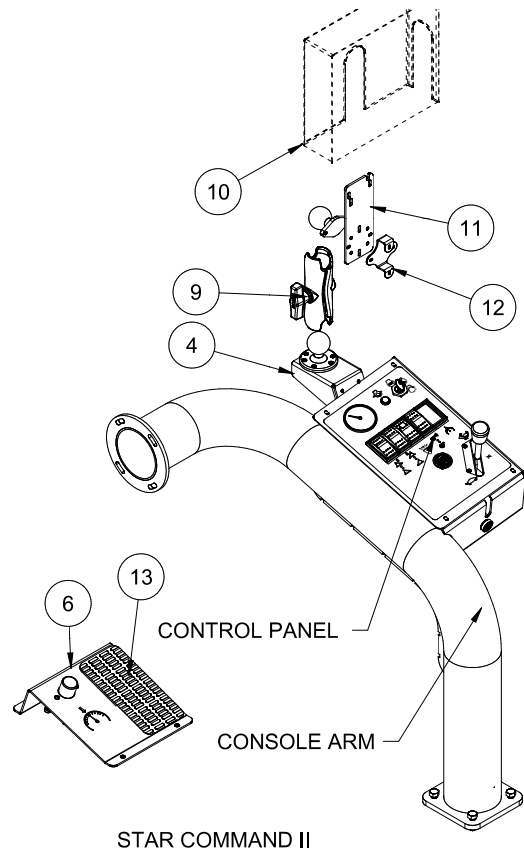
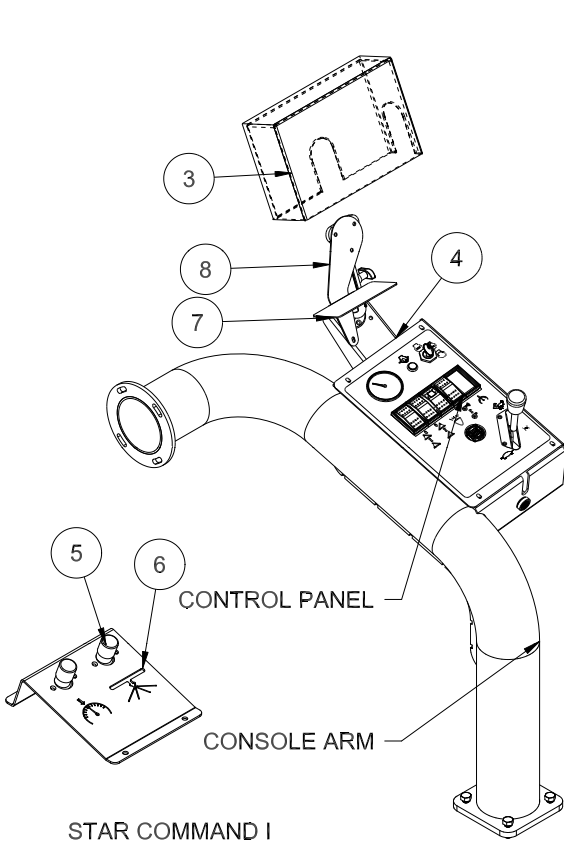
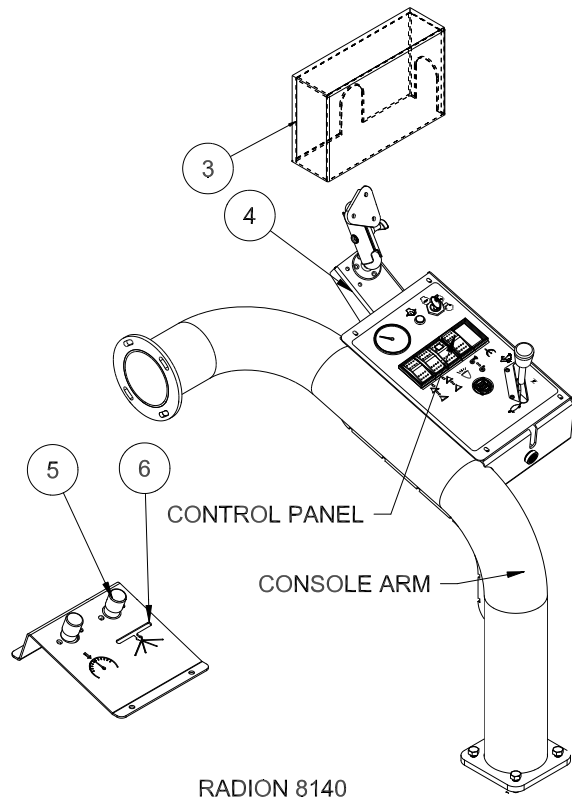
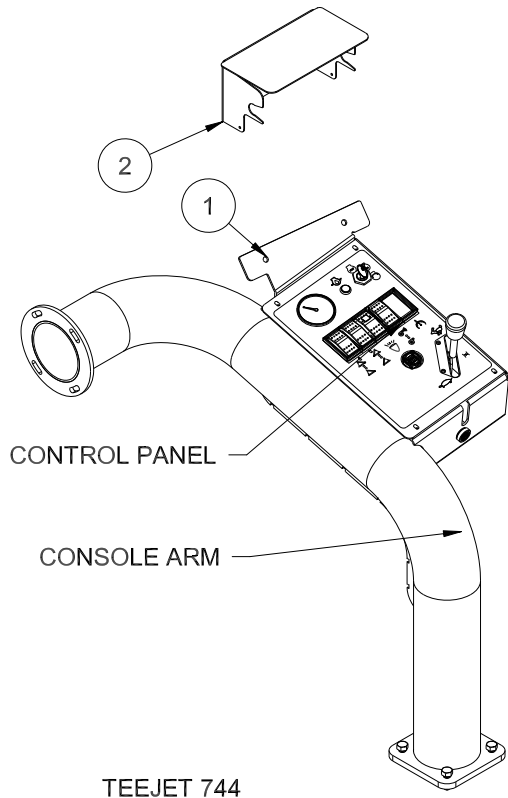

## CONTROL MOUNTS

| REF# | PART#  | DESCRIPTION                  | QUANTITY |
|------|--------|------------------------------|----------|
| 1    | 10-718 | 744 Control Mount            | 1        |
| 2    | 20-782 | Rain Cover                   | 1        |
| 3    | 20-781 | Cover for Radion Control     | 1        |
| 4    | 10-721 | Short Ram Mount              | 1        |
| 5    | 33-509 | Master Boom Switch           | 1        |
| 6    | 10-705 | Switch Foot Plate            | 1        |
| 7    | 10-716 | DynaJet Control Cover        | 1        |
| 8    | 10-719 | Radion/DynaJet Control Mount | 1        |
| 9    |        | MATRIX RAM Mount             | 1        |
| 10   | 20-836 | Star Command II Cover        | 1        |
| 11   | 32-726 | MATRIX Switch Mount          | 1        |
| 12   | 20-856 | MATRIX Control Adapter       | 1        |
| 13   | 45-132 | Foot Grip                    | 1        |

# 1207D/1208D/1215D/1218D/1220D PLUMBING DRAWING

| <u>BOOM</u> | <u>LEFT HOSE</u> | <u>CENTER HOSE</u> | <u>RIGHT HOSE</u> |
|-------------|------------------|--------------------|-------------------|
| 15"         | 9032-115         | 9032-90            | 9032-126          |
| 18'         | 9032-125         | 9032-90            | 9032-136          |
| 20'         | 9032-135         | 9032-90            | 9032-146          |

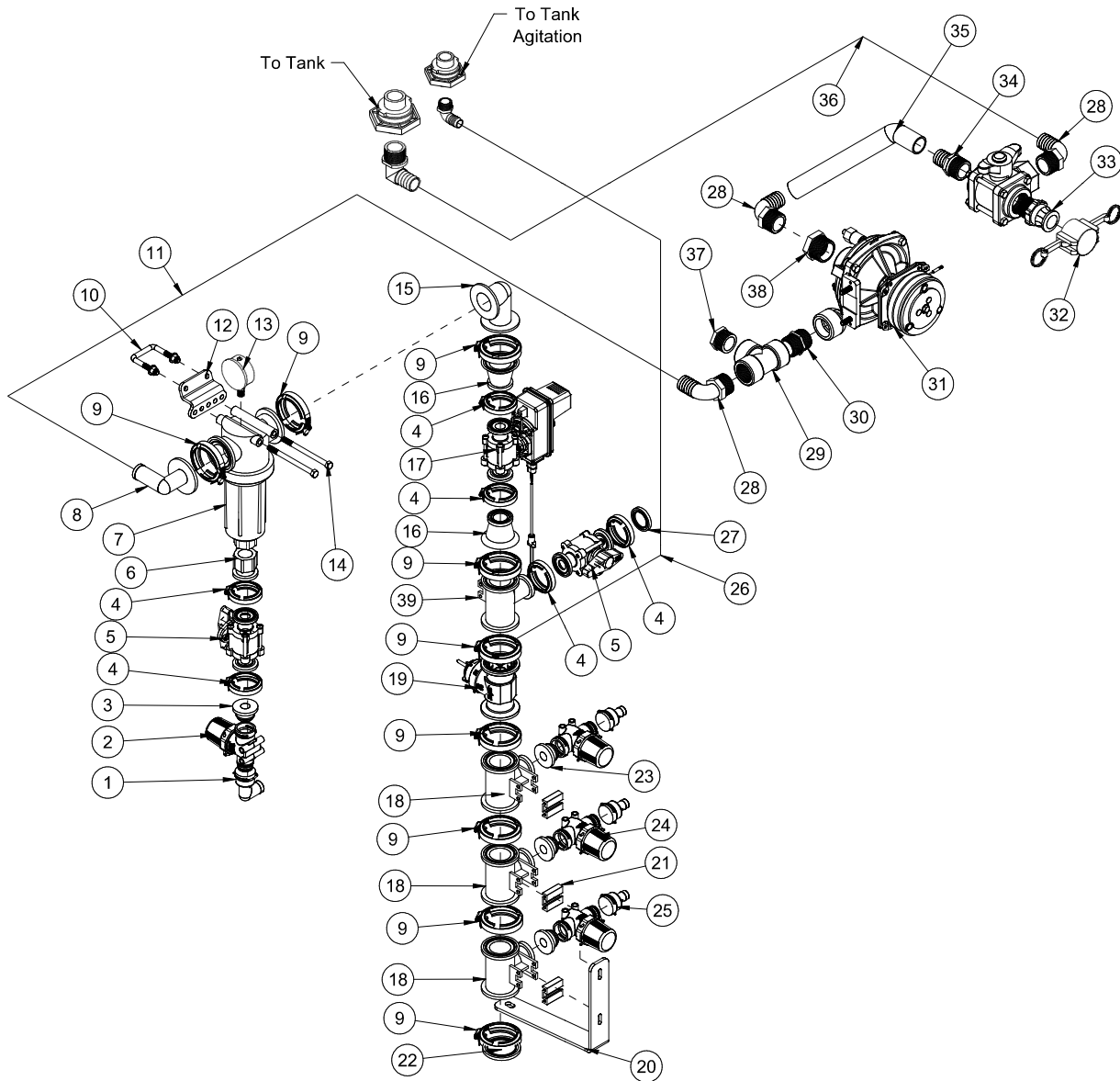



## 1207D/1208D/1215D/1218D/1220D PLUMBING PARTS LIST

| REF# | PART#        | DESCRIPTION   | QUANTITY |
|------|--------------|---|----------|
| 1    | 14-671       | Elbow   | 1        |
| 2    | 14-801       | Agitator Line Strainer, 50 Mesh                       | 1        |
|      | 14-802       | Replacement 50 Mesh Screen                            |          |
|      | 14-803       | Decal, Clean Strainer                                 | 1        |
| 3    | 15-825       | #50 Male Quick Coupler                                | 1        |
| 4    | 15-740       | #50 Series Clamp                                      | 6        |
| 5    | 15-738       | Flanged Ball Valve                                    | 2        |
| 6    | 15-735       | #50 x 1 FTP Fitting                                   | 1        |
| 7    | 14-628       | Flanged Strainer with 80 Mesh screen                  | 1        |
|      | 16-968-03    | Screen (50 mesh)                                      | 1        |
| 8    | 15-739       | #75 90° Hose Barb                                     | 1        |
| 9    | 15-741       | #75 Series Clamp                                      | 9        |
| 10   | 17-537       | Square U-bolt   | 1        |
| 11   | 8897         | 1 <sup>1</sup> / <sub>4</sub> " Discharge Hose        | 57"      |
|      | 18-116       | Hose Clamp  | 2        |
| 12   | 30-551       | Filter Mount  | 1        |
| 13   | 16-281       | Liquid Filled Gauge                                   | 1        |
| 14   | HB-38-16-500 | Hex Bolt, <sup>3</sup> / <sub>8</sub> - 16 x 5        | 2        |
|      | HNFL-38-16   | Flange Whiz-loc Nut, <sup>3</sup> / <sub>8</sub> - 16 | 2        |
| 15   | 15-734       | #75 Elbow Coupling                                    | 1        |
| 16   | 15-748       | Reducer Coupling (#75 to #50)                         | 2        |
| 17   | 20-785       | Regulator Valve                                       | 1        |
| 18   | 15-775       | Reducer Tee   | 3        |
| 19   | 20-684       | #802 Flow Meter                                       | 1        |
| 20   | 20-887       | Lower Bracket   | 1        |
| 21   | 15-743-03    | Mounting Rail   | 2        |
|      | 15-743-06    | SS Screw  | 8        |
| 22   | 15-742       | #75 Inlet Cover                                       | 1        |
| 23   | 15-825       | #50 Male Quick Coupler                                | 3        |
| 24   | 14-607       | QC Strainer 100 Mesh                                  | 3        |
|      | 14-609       | Replacement 100 Mesh Screen                           |          |
| 25   | 14-660       | <sup>3</sup> / <sub>4</sub> Quick Connect Hose Barb   | 3        |
| 26   | 8896         | 1" Suction Hose                                       | 56"      |
|      | 18-220       | Hose Clamp  | 2        |
| 27   | 15-778       | Blank Gauge Port Flange                               | 1        |
| 28   | 16-156       | Elbow   | 3        |
| 29   | 18-390       | Tee   | 1        |
| 30   | 16-880       | Nipple  | 1        |
| 31   | 15-970       | Pump  | 1        |
| 32   | 16-935       | Quick Coupler Cap                                     | 1        |
| 33   | 16-180       | Quick Coupler Male                                    | 1        |
| 34   | 16-161       | Fitting   | 1        |
| 35   | 8897         | 1 <sup>1</sup> / <sub>4</sub> " Discharge Hose        | 24"      |
|      | 18-116       | Hose Clamp  | 2        |
| 36   | 8897         | 1 <sup>1</sup> / <sub>4</sub> " Discharge Hose        | 26"      |
|      | 18-116       | Hose Clamp  | 2        |
| 37   | 10-389       | Plug  | 1        |
| 38   | 16-825       | Hex Bushing   | 1        |
| 39   | 30-164       | Tapped Reducer Tee                                    | 1        |
|      | 20-670-04    | Pressure Sensor                                       | 1        |

# 1207D/1208D DYNAJET WIRING

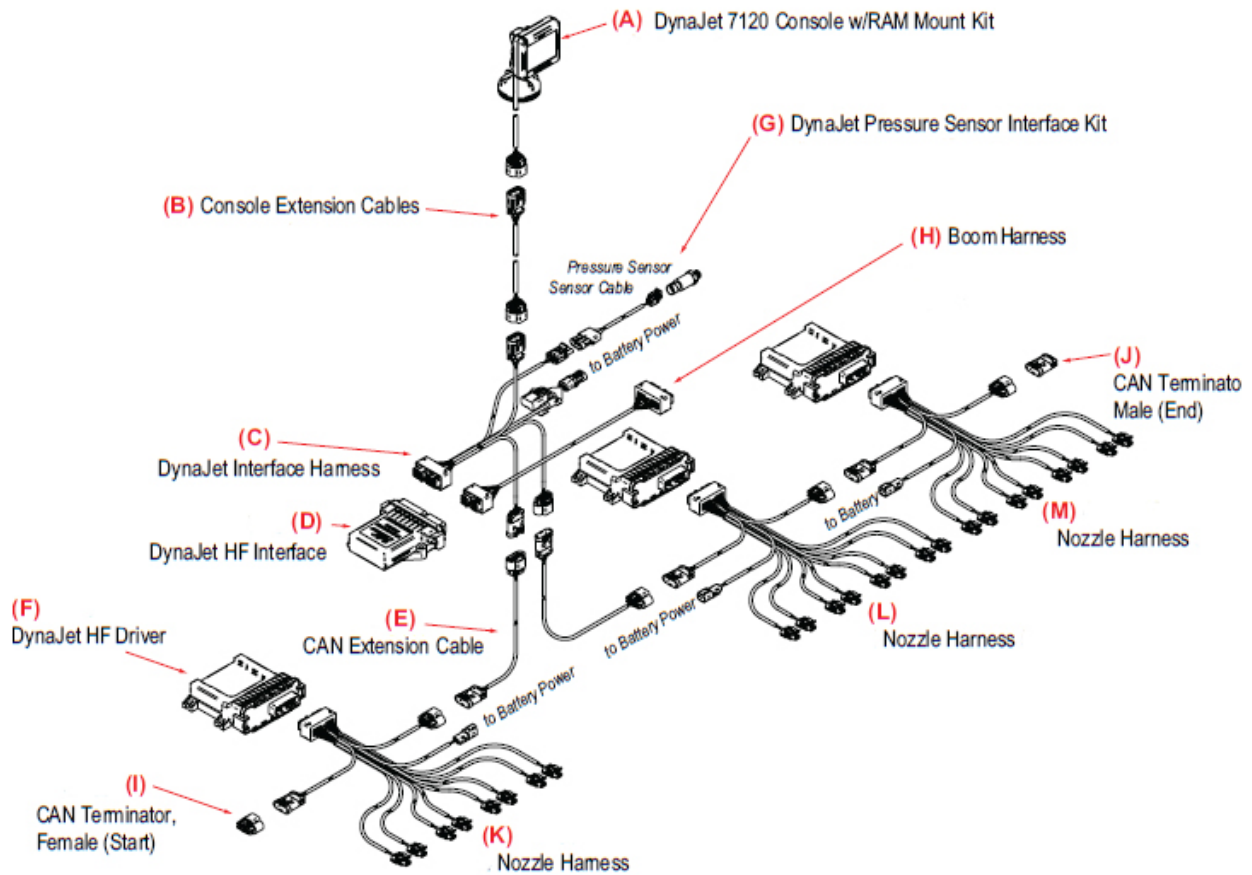

| REF# | PART#     | DESCRIPTION                | QUANTITY |
|------|-----------|----------------------------|----------|
| A    | 20-670-06 | DynaJet 7120 Console       | 1        |
| B    |           | Console Extension Cable    | 1        |
| C    |           | DynaJet Interface Harness  | 1        |
| D    | 20-670-07 | DynaJet HF Interface       | 1        |
| E    |           | CAN Extension Cables       | 1        |
| F    | 20-670-05 | DynaJet HF Driver          | 3        |
| G    | 20-670-04 | Pressure Sensor            | 1        |
|      |           | Pressure Sensor Cable      | 1        |
| H    |           | Boom Harness               | 1        |
| I    | 20-670-09 | Terminator, Female (Start) | 1        |
| J    | 20-670-08 | Terminator, Male (End)     | 1        |
| K    | 20-670-01 | Left Nozzle Harness        | 1        |
| L    | 20-670-02 | Center Nozzle Harness      | 1        |
| M    | 20-670-03 | Right Nozzle HARness       | 1        |

NOTE: This is for 20" spacing used with the Radion system.

# 1207D/1208D MODULE MOUNTS

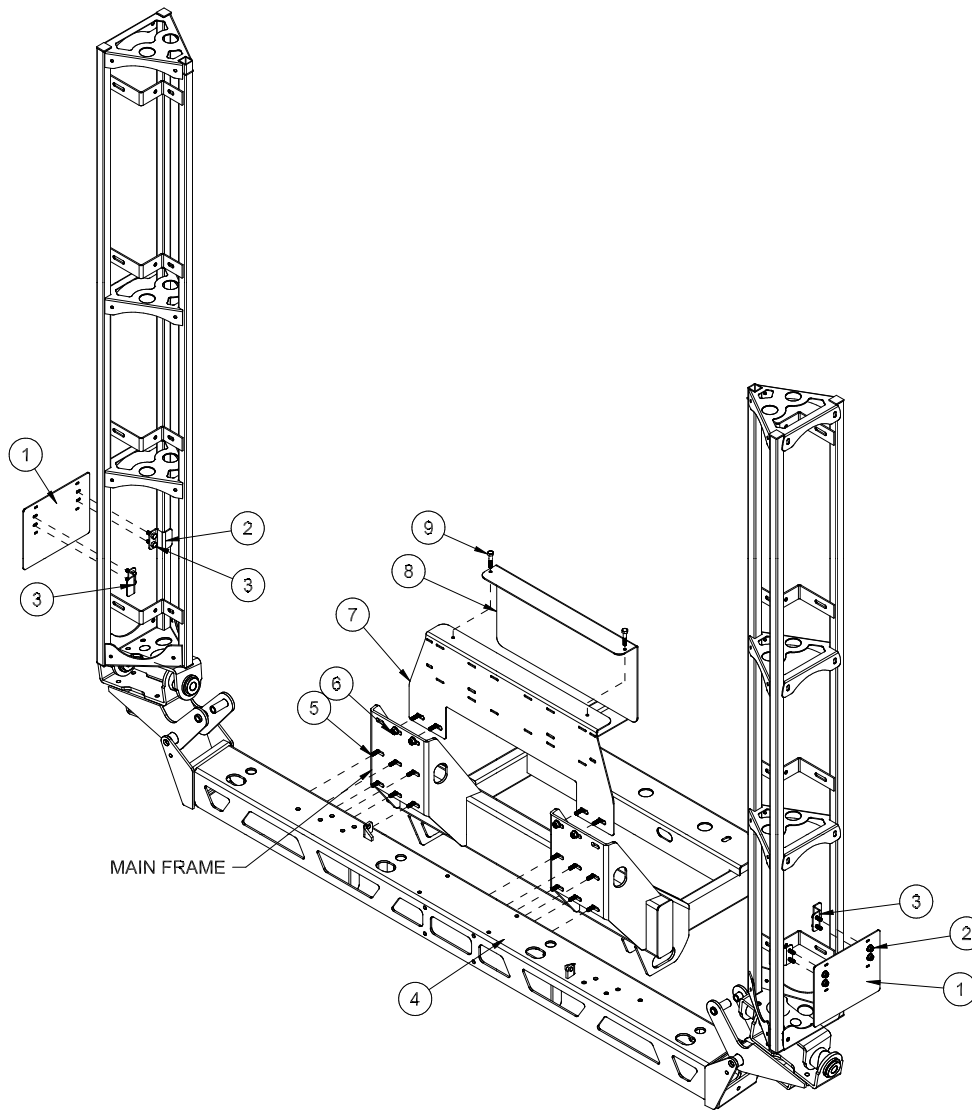

| REF# | PART#          | DESCRIPTION                                       | QUANTITY |
|------|----------------|---|----------|
| 1    | 20-665         | Drive Module Bracket                              | 2        |
| 2    | 20-664         | Z Bracket   | 4        |
| 3    | HSTP-14-20-075 | Machine Screw, $\frac{1}{4}$ - 20 x $\frac{3}{4}$ | 10       |
|      | HNFL-14-20     | Flange Whiz Lock Nut, $\frac{1}{4}$ - 2           | 10       |
| 4    |                | Center Boom Mount                                 | 1        |
| 5    | HB-38-16-125   | Bolt, $\frac{3}{8}$ - 16 x $1\frac{1}{4}$         | 12       |
|      | HW-38          | Flat Washer, $\frac{3}{8}$                        | 12       |
|      | HW-5/16        | Flat Washer, $\frac{5}{16}$                       | 12       |
|      | HNFL-516-18    | Flange Whiz Lock Nut, $\frac{3}{8}$ -16           | 12       |
| 6    | HB-38-16-125   | Bolt, $\frac{3}{8}$ - 16 x $1\frac{1}{4}$         | 4        |
|      | HW-3/8         | Flat Washer. $\frac{3}{8}$                        | 4        |
|      | HNFL-516-18    | Flange Whiz Lock Nut, $\frac{3}{8}$ -16           | 4        |
| 7    | 30-577         | Module mount Bracket                              | 1        |
| 8    | 20-920         | Module Cover Bracket                              | 1        |
| 9    | HB-516-18-150  | Hex Bolt, $\frac{5}{16}$ -18 x $1\frac{1}{2}$     | 2        |
|      | HNFL-516-18    | Flange Whiz-loc Nut, $\frac{5}{16}$ -18           | 2        |

# MATRIX 908® WIRING FOR 1215D/1218D/1220D

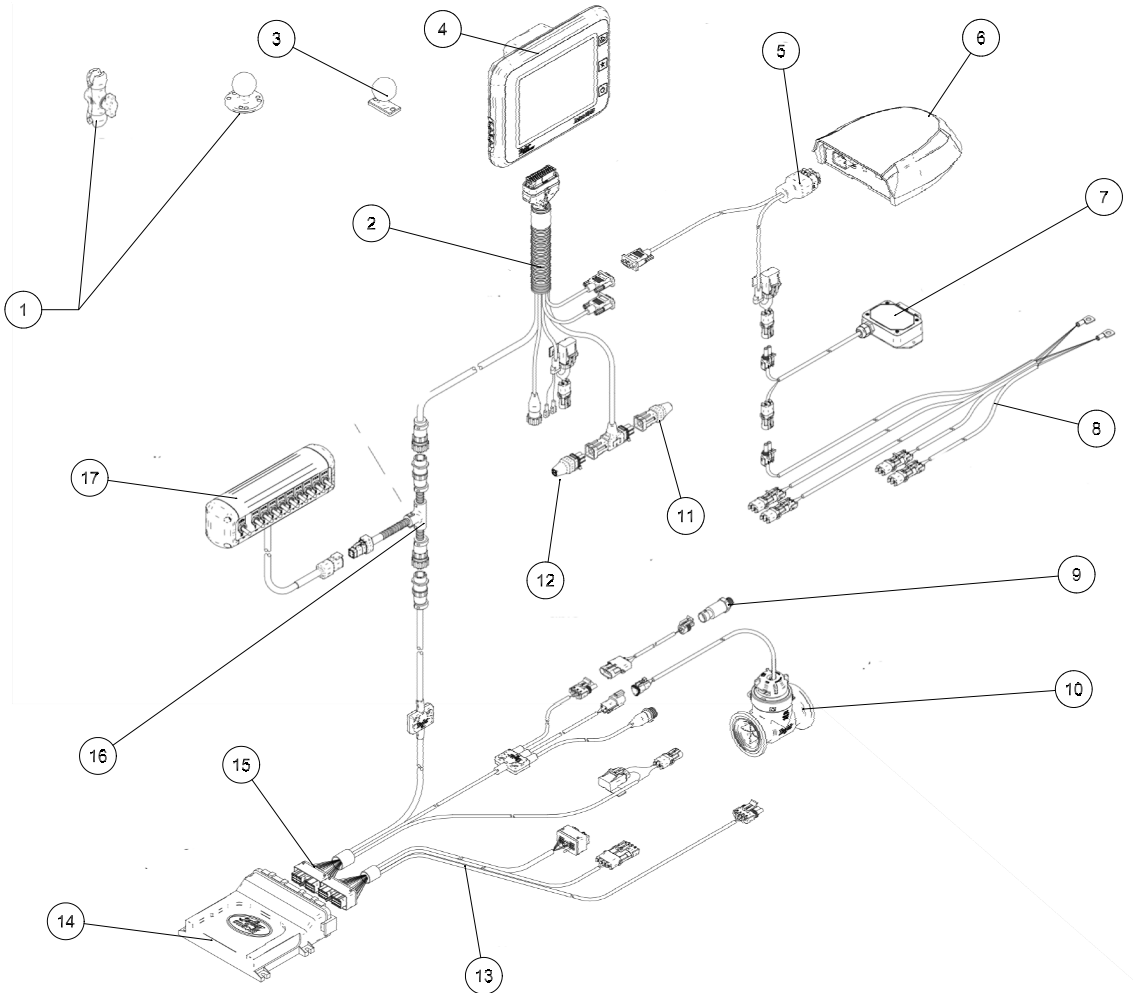

| REF# | PART#     | DESCRIPTION                             | QUANTITY |
|------|-----------|---|----------|
| 1    |           | RAM Mount                               | 1        |
| 2    | 20-918    | MATRIX 908® Harness                     | 1        |
| 3    |           | RAM Base                                | 1        |
| 4    |           | MATRIX 908® Console                     | 1        |
| 5    |           | Antenna Cable                           | 1        |
| 6    | 20-855-01 | RXA-52 GNSS Antenna                     | 1        |
| 7    | 20-686-02 | Switch Box                              | 1        |
| 8    |           | Power Cable                             | 1        |
| 9    | 20-670-04 | Pressure Sensor                         | 1        |
| 10   | 20-684    | Flow Meter                              | 1        |
| 11   |           | Terminator, Male                        | 1        |
| 12   |           | Terminator, Female                      | 1        |
| 13   |           | DynaJet Interface Boom Harness          | 1        |
| 14   | 20-917    | IC45 Sprayer Module                     | 1        |
| 15   |           | IC45 Harness                            | 1        |
| 16   |           | TeeJet In-Cab Cable                     | 1        |
| 17   | 20-919    | Switch Box                              | 1        |
| NS   | 20-855    | KIT, IC45 & MATRIX 908® WITH ISO UNLOCK |          |

# DYNAJET WIRING FOR 1215D/1218D/1220D

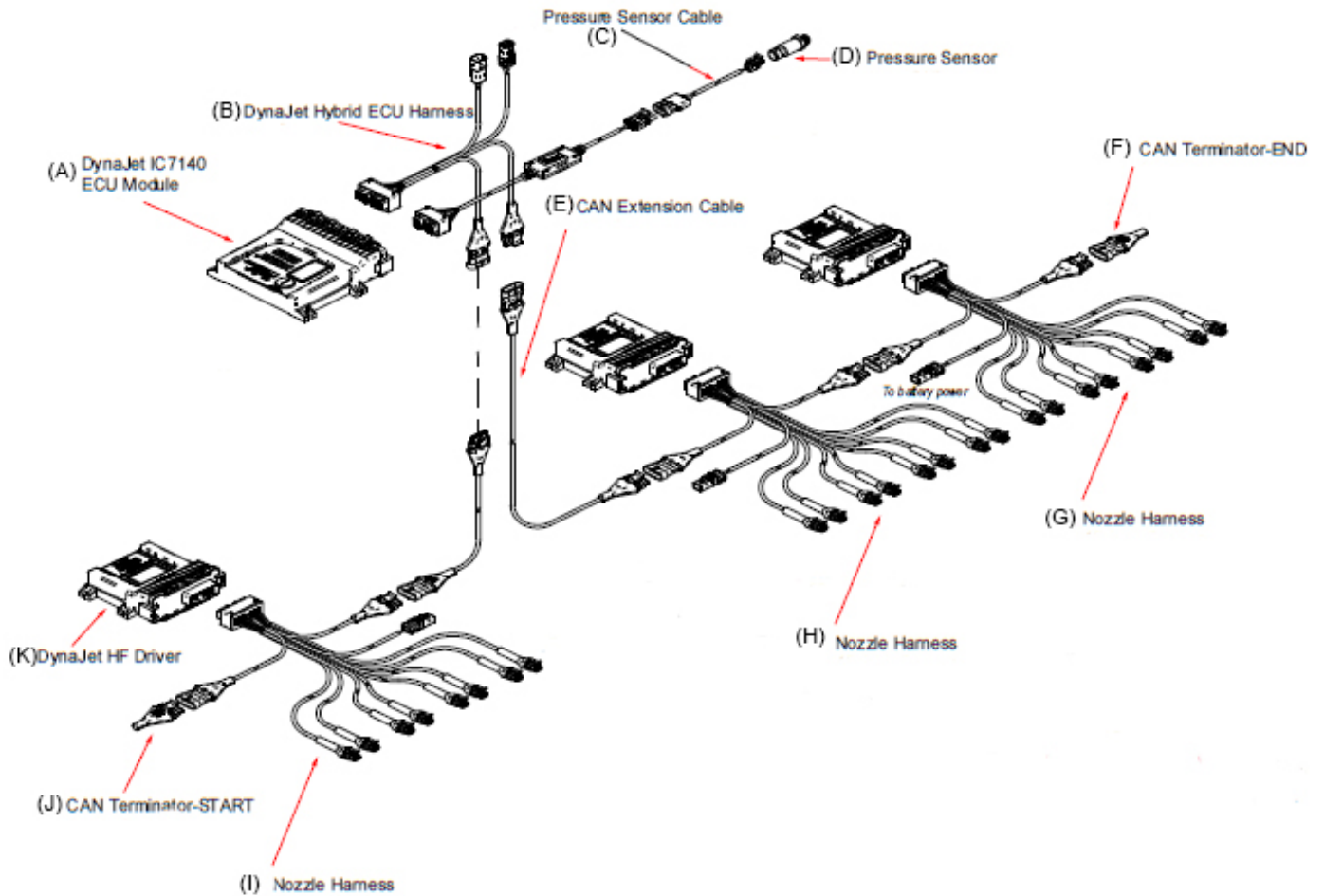

| REF# | PART#     | DESCRIPTION               | QUANTITY |
|------|-----------|---------------------------|----------|
| A    |           | DynaJet IUC7140 Module    | 1        |
| B    |           | Harness, IC7140 to IC35   | 1        |
| C    |           | Cable, Pressure Sensor    | 1        |
| D    | 20-670-04 | Pressure Sensor           | 1        |
| E    |           | CAN Extension Cable       | 1        |
| F    | 20-670-08 | CAN Terminator End        | 1        |
| G    | 20-806-03 | Right Harness, DJ Driver  | 1        |
| H    | 20-806-02 | Center Harness, DJ Driver | 1        |
| I    | 20-806-01 | Left Harness, DJ Driver   | 1        |
| J    | 20-670-09 | CAN Terminator Start      | 1        |
| K    | 20-670-05 | DynaJet Driver            | 3        |

# 1215D/1218D/1220D MODULE MOUNTS

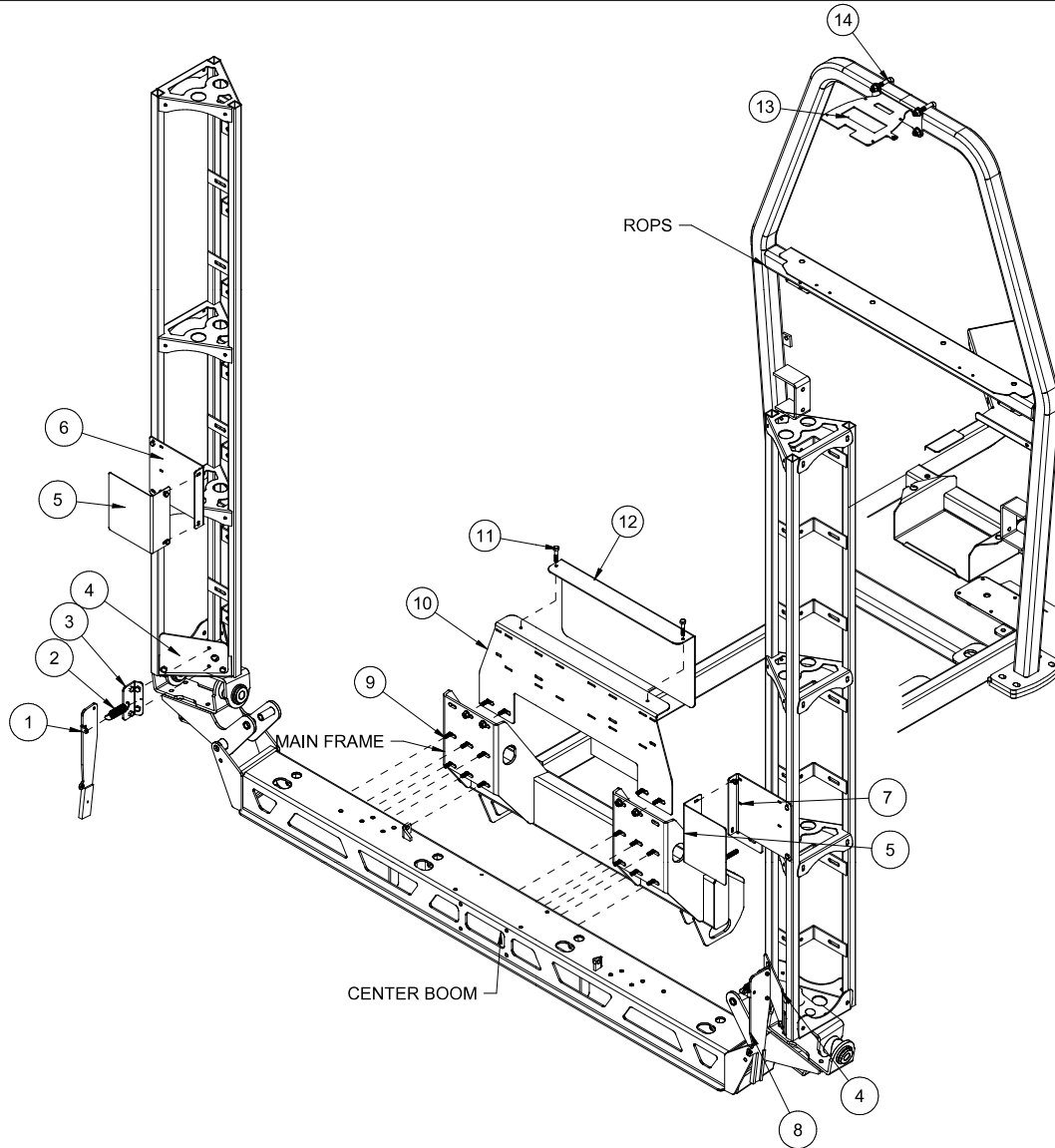

| REF# | PART#         | DESCRIPTION                                       | QUANTITY |
|------|---------------|---|----------|
| 1    | 17-562        | LH Break-Away Arm                                 | 1        |
|      | 8946-3.5      | Plastic Wear Strip                                | 2        |
|      | HRS-316-050   | Rivet, $\frac{3}{16} \times \frac{1}{2}$          | 2        |
| 2    | 11-050        | Spring  | 2        |
| 3    | 17-560        | Hinge Mount                                       | 2        |
| 4    | 17-559        | Break-Away Mount                                  | 2        |
| 5    | 20-796        | Bracket Cover                                     | 2        |
| 6    | 20-795        | LH Driver Module Bracket                          | 1        |
| 7    | 20-793        | RH Driver Module Bracket                          | 1        |
| 8    | 17-561        | RH Break-Away Arm                                 | 1        |
| 9    | HB-38-16-125  | Hex Bolt,   | 16       |
|      | HW-38         | Flat Washer, $\frac{3}{8}$                        | 16       |
|      | HNFL-38-16    | Flange Whiz-loc Nut,                              | 16       |
| 10   | 30-577        | Module Mount Bracket                              | 1        |
| 11   | HB-516-18-150 | Hex Bolt, $\frac{5}{16} - 18 \times 1\frac{1}{2}$ | 2        |
|      | HNFL-516-18   | Flange Whiz-loc Nut, $\frac{5}{16} - 18$          | 2        |
| 12   | 20-920        | Module Cover Bracket                              | 1        |
| 13   | 20-770        | Receiver Mount                                    | 1        |
| 14   | 17-537        | U-Bolt  | 2        |

# 14-801/14-607 STRAINER

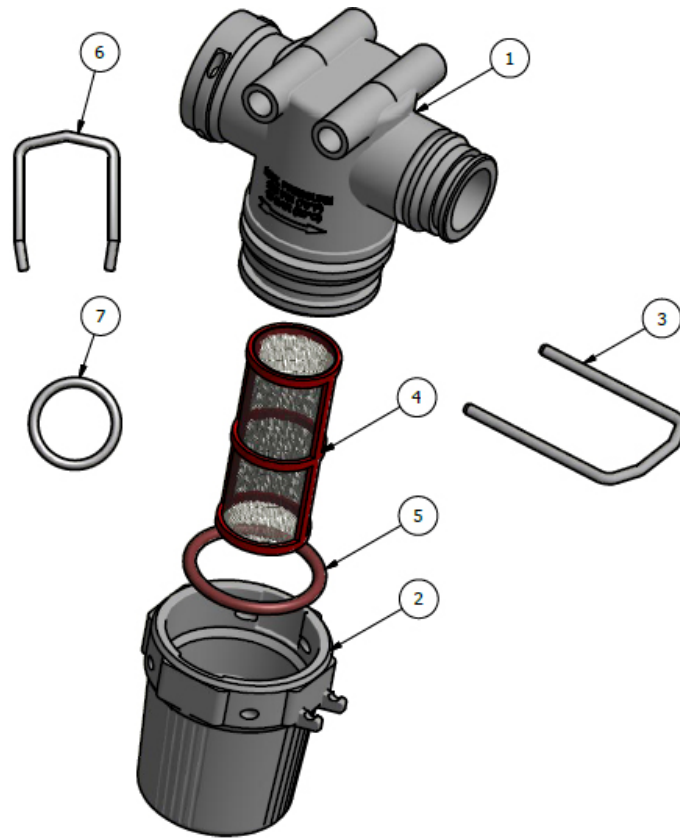

| REF# | PART#     | DESCRIPTION                                     | QUANTITY |
|------|-----------|---|----------|
| 1    |           | QC Strainer Head                                | 1        |
| 2    | 14-801-01 | Bowl  | 1        |
| 3    |           | Strainer QC Retaining Clip                      | 1        |
| 4*   | 14-802    | 50 Mesh Screen                                  | 1        |
| **   | 14-609    | 100 Mesh Screen                                 | 1        |
| 5    | 14-801-02 | Viton O-ring                                    | 1        |
| 6    | 15-553-01 | Retaining Clip                                  | 1        |
| 7    | 15-553-02 | Viton O-ring                                    | 1        |
| *    | 14-801    | Agitation Strainer Assembly with 50 Mesh Screen |          |
| **   | 14-607    | QC Strainer Assembly with 100 Mesh Screen       |          |

# 15-737/ 14-628 FLANGED STRAINER DRAWING

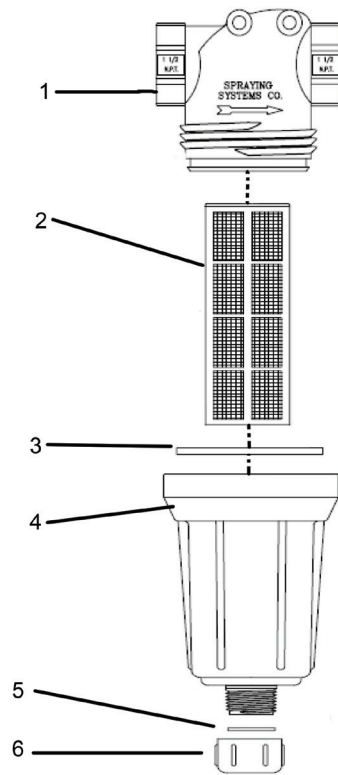

| REF# | PART#     | DESCRIPTION                                   | QUANTITY |
|------|-----------|---|----------|
| 1    | 15-737-01 | Strainer Head 75 Series                       | 1        |
| 2*   | 16-968-03 | 50 Mesh Screen                                | 1        |
| **   | 16-968-05 | 80 Mesh Screen                                | 1        |
| 3    | 14-521-02 | EPDM Gasket                                   | 1        |
| 4    | 14-521-03 | Bowl 1" NPT                                   | 1        |
| 5    | 14-521-04 | EPDM Rubber gasket                            | 1        |
| 6    | 14-521-05 | Cap   | 1        |
| *    | 15-737    | Flanged Strainer Assembly with 50 Mesh Screen |          |
| **   | 14-628    | Flanged Strainer Assembly with 80 Mesh Screen |          |



# 15-743 MANIFOLD VALVE DRAWING

15-818  
15-817

#75 Fitting Oring  
#50 Fitting Oring

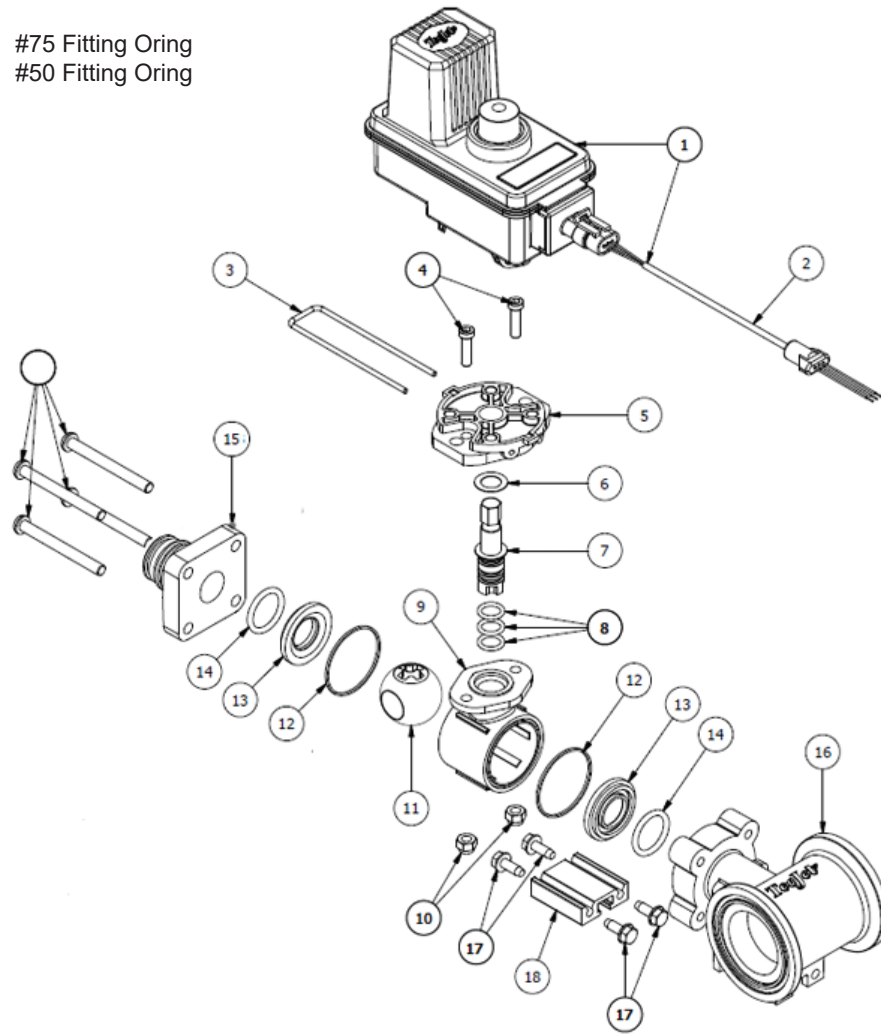

| REF# | PART#     | DESCRIPTION                            | QUANTITY |
|------|-----------|--|----------|
| 1    | 15-552-23 | Motor                                  |          |
| 2    | 15-878    | Metri-Pack Cable (comes with motor)    | 1        |
| 3    | 15-552-24 | Retaining Clip                         | 1        |
| 4    | 15-552-25 | Socket Head Cap Screw, Stainless Steel | 2        |
| 5    | 15-552-26 | Motor Adapter, Polypropylene           | 1        |
| 6*   | 15-517-11 | Thrust Washer, Teflon                  | 1        |
| 7    | 15-552-27 | Stem, Stainless Steel                  | 1        |
| 8    | 15-552-05 | O-ring, Viton                          | 3        |
| 9    | 15-517-16 | Body, Nylon                            | 1        |
| 10   |           | Lock Nut, Stainless Steel              | 2        |
| 11   | 15-743-04 | Ball, Polypropylene                    | 1        |
| 12*  | 15-552-13 | Gasket, Viton                          | 2        |
| 13*  | 15-517-19 | Seal, Teflon                           | 2        |
| 14*  | 15-517-20 | O-ring, Viton                          | 2        |
| 15   | 15-743-01 | End Cap                                | 1        |
| 16   | 15-743-02 | #75 Tee Body                           | 1        |
| 17   | 15-743-06 | Screw, SS                              | 4        |
| 18   | 15-743-03 | Mounting Rail Aluminum                 | 1        |

\* 15-552-10 Spare Parts Kit (includes all \* items)  
15-743-05 Single Valve (shown)

# 20-817 REGULATOR VALVE

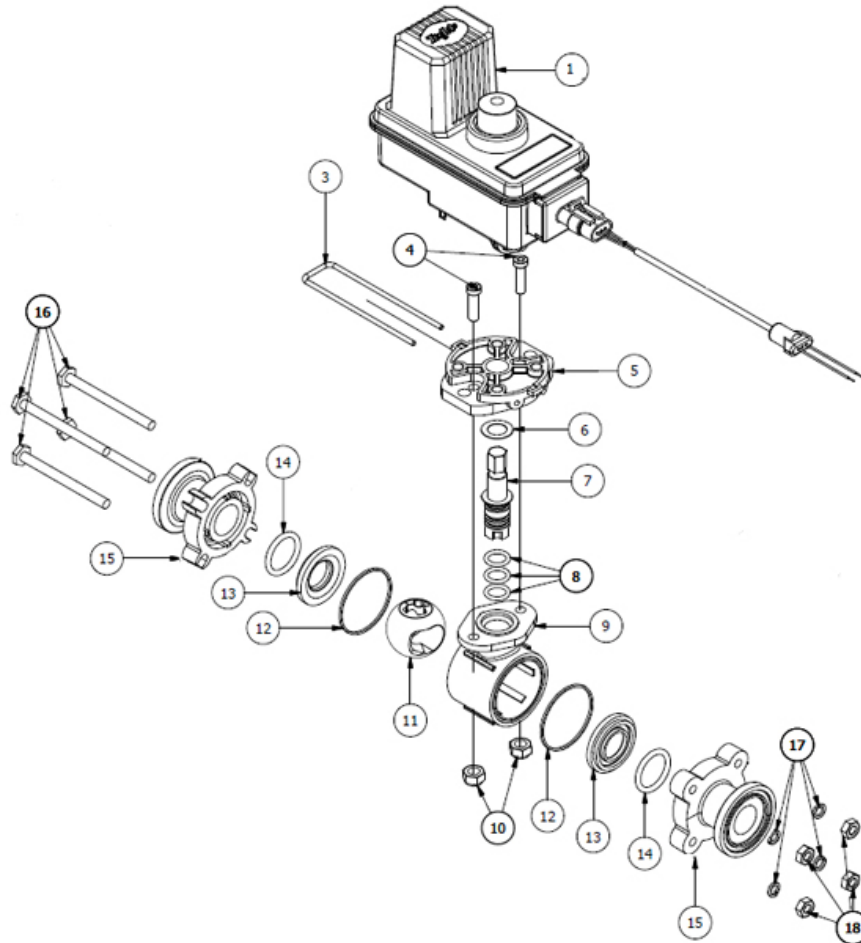

| REF# | PART#     | DESCRIPTION                            | QUANTITY |
|------|-----------|--|----------|
| 1    | 20-817-01 | Motor                                  | 1        |
| 3    | 15-552-24 | Retaining Clip                         | 1        |
| 4    |           | Socket Head Cap Screw, Stainless Steel | 2        |
| 5    | 15-552-26 | Motor Adapter, Polypropylene           | 1        |
| 6*   | 15-517-11 | Thrust Washer, Teflon                  | 1        |
| 7    | 15-552-27 | Stem, Stainless Steel                  | 1        |
| 8    | 15-552-05 | O-ring, Viton                          | 3        |
| 9    | 15-517-16 | Body, Nylon                            | 1        |
| 10   |           | Nylon Lock Nut, Stainless Steel        | 2        |
| 11   |           | Ball, Polypropylene                    | 1        |
| 12*  | 15-552-13 | Gasket, Viton                          | 2        |
| 13*  | 15-517-19 | Seal, Teflon                           | 2        |
| 14*  | 15-517-20 | O-ring, Viton                          | 2        |
| 15   | 15-743-01 | End Cap                                | 1        |
| 16   |           | SS Hex Bolt, 1/4 - 20 x 3              | 4        |
| 17   |           | SS Lock Washer, 1/4                    | 4        |
| 18   | 15-517-23 | SS Nut, 1/4 - 20                       | 4        |
| *    | 15-552-10 | Spare Parts Kit                        |          |
|      | 20-817    | Complete Regulator Valve               |          |

# 20-785 REGULATOR VALVE

15-818 #75 Fitting Oring  
 15-817 #50 Fitting Oring

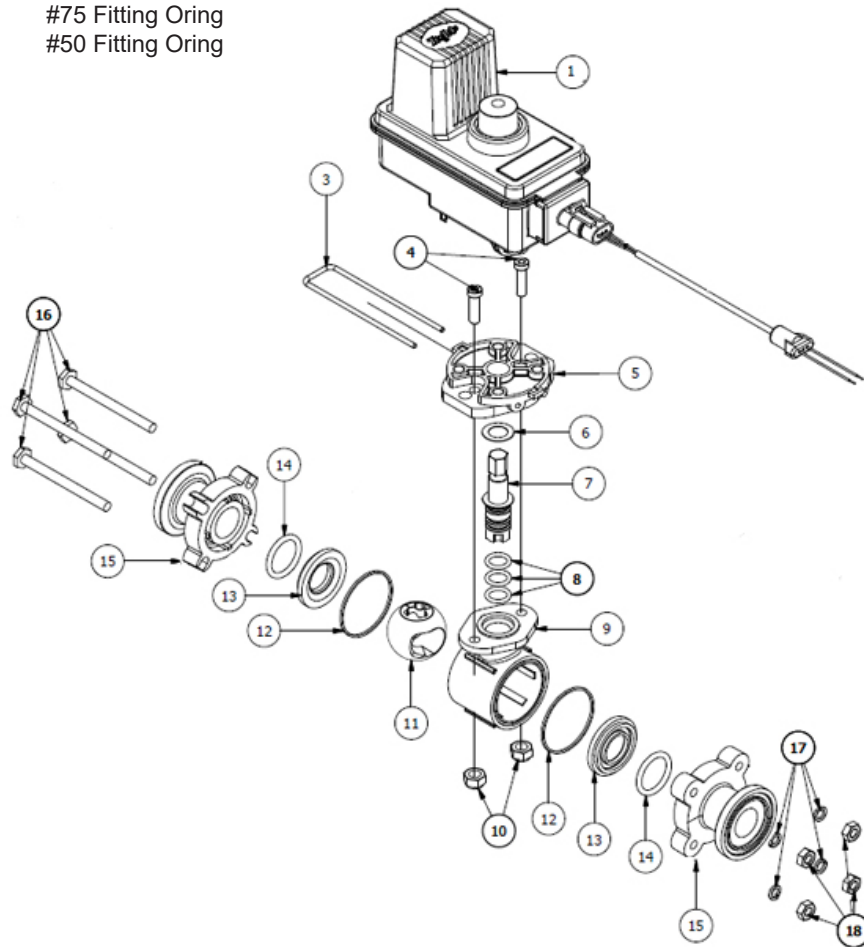

| REF# | PART#     | DESCRIPTION                            | QUANTITY |
|------|-----------|--|----------|
| 1    | 20-785-01 | Motor, 6RPM                            |          |
| 3    | 15-552-24 | Retaining Clip                         | 1        |
| 4    |           | Socket Head Cap Screw, Stainless Steel | 2        |
| 5    | 15-552-26 | Motor Adapter, Polypropylene           | 1        |
| 6*   | 15-517-11 | Thrust Washer, Teflon                  | 1        |
| 7    | 15-552-27 | Stem, Stainless Steel                  | 1        |
| 8    | 15-552-05 | O-ring, Viton                          | 3        |
| 9    | 15-517-16 | Body, Nylon                            | 1        |
| 10   |           | Nylon Lock Nut, Stainless Steel        | 2        |
| 11   |           | Ball, Polypropylene                    | 1        |
| 12*  | 15-552-13 | Gasket, Viton                          | 2        |
| 13*  | 15-517-19 | Seal, Teflon                           | 2        |
| 14*  | 15-517-20 | O-ring, Viton                          | 2        |
| 15   | 15-743-01 | End Cap                                | 1        |
| 16   |           | SS Hex Bolt, 1/4 - 20 x 3              | 4        |
| 17   |           | SS Lock Washer, 1/4                    | 4        |
| 18   | 15-517-23 | SS Nut, 1/4 - 20                       | 4        |
| *    | 15-552-10 | Spare Parts Kit                        |          |
|      | 20-785    | Complete Regulator Valve               |          |

# 17-580 20' HEAVY BOOM

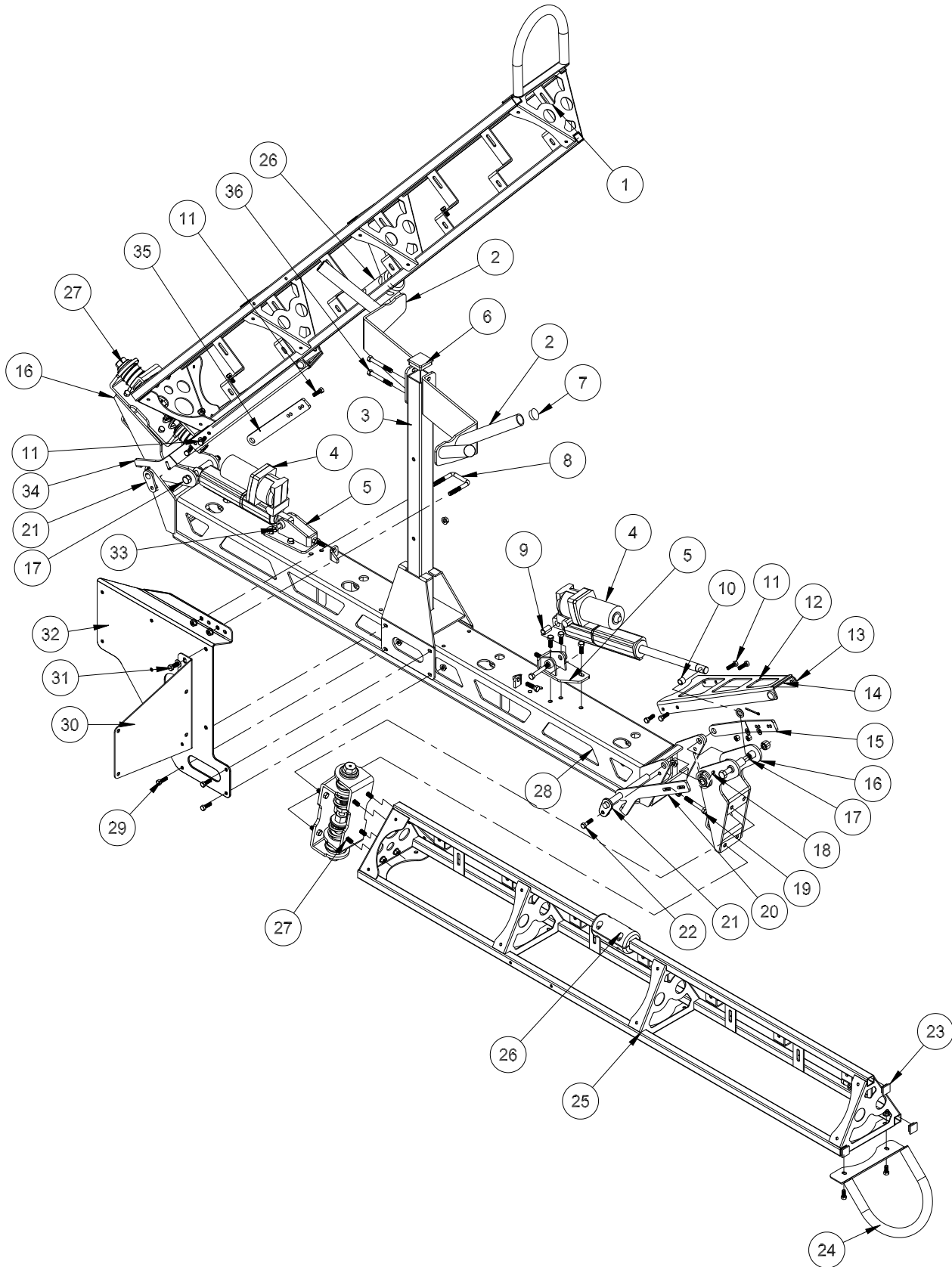

Accessories

# 17-580 20' HEAVY BOOM

| REF# | PART#           | DESCRIPTION   | QUANTITY |
|------|-----------------|---|----------|
| 1    | 17-652          | Left Boom Arm   | 1        |
| 2    | 17-631          | V-Boom Nest   | 2        |
| 3    | 17-578          | Boom Nest Post  | 1        |
| 4    | 30-214          | 10" Electric Hydraulic Actuator                           | 2        |
| 5    | 30-184          | Actuator Mount  | 2        |
|      | HN-38-16        | Hex Nut, $\frac{3}{8}$ - 16 (adjustment Hex Bolt)         | 4        |
|      | HB-38-16-100    | Hex Bolt, $\frac{3}{8}$ - 16 x 1                          | 6        |
|      | HW-38           | Flat Washer, $\frac{3}{8}$                                | 6        |
|      | HNFL-38-16      | Flange Whiz-loc Nut, $\frac{3}{8}$ -16                    | 6        |
| 6    | 18-297          | Cap Plug  | 1        |
| 7    | 17-619          | Push in Plug  | 4        |
| 8    | 17-537          | Square U-Hex Bolt   | 1        |
| 9    | 18-036          | 1" Bushing (part of 30-214)                               | 2        |
| 10   | 18-234          | $\frac{1}{2}$ " Bushing (part of 30-214)                  | 2        |
| 11   | HB-516-18-100   | Hex Bolt, $\frac{5}{16}$ -16 x 1                          | 8        |
|      | HW-516          | Flat Washer, $\frac{5}{16}$                               | 4        |
|      | HNTL-516-18     | Nylon Lock Nut, $\frac{5}{16}$ - 18                       | 8        |
| 12   | 32-564          | Boom Lock   | 2        |
| 13   | 8803-2.75       | Trim Lace, $2\frac{3}{4}$                                 | 2        |
| 14   | 42-116          | Rubber Insert   | 4        |
| 15   | 17-588          | Lock Hinge, RH  | 1        |
| 16   | 30-185          | Arm Pivot Hinge   | 2        |
|      | HG-14-28-180    | Grease Fitting, $\frac{1}{4}$ - 28 x 180°                 | 2        |
|      | 76-128          | Bushing   | 4        |
| 17   | HB-12-13-500    | Hex Bolt, $\frac{1}{2}$ - 13 x 5                          | 2        |
|      | HNTL-12-13      | Nylon Lock Nut, $\frac{1}{2}$ - 13                        | 2        |
| 18   | 17-597          | Torsion Spring, RH  | 1        |
| 19   | HB-38-16-175    | Hex Bolt, $\frac{3}{8}$ - 16 x $1\frac{3}{4}$             | 2        |
|      | HNFL-38-16      | Flange Whiz-loc Nut, $\frac{3}{8}$ -16                    | 4        |
| 20   | 17-589          | Limit Hinge, RH   | 1        |
| 21   | 17-596          | Hinge Pin w/Spacer  | 2        |
|      | HP-18-100       | Cotter Pin, $\frac{1}{8}$ x 1                             | 2        |
| 22   | HB-516-18-100   | Hex Bolt, $\frac{5}{16}$ -16 x 1                          | 2        |
|      | HNFL-516-18     | Flange Whiz-loc Nut, $\frac{5}{16}$ - 18                  | 2        |
| 23   | 30-258          | 1" 10-14ga Ribbed Plug                                    | 10       |
| 24   | 17-541          | Boom End Guard  | 2        |
|      | HBFL-516-18-075 | Flange Whiz-loc Bolt, $\frac{5}{16}$ - 18 x $\frac{3}{4}$ | 4        |
|      | HNFL-516-18     | Flange Whiz-loc Nut, $\frac{5}{16}$ - 18                  | 4        |
| 25   | 17-653          | Right Boom Arm  | 1        |
| 26   | 17-573          | Guide Block Set   | 2        |
|      | HB-14-20-125    | Hex Bolt, $\frac{1}{4}$ -20 x $1\frac{1}{4}$              | 8        |
|      | HNTL-14-20      | Nylon Lock Nut, $\frac{1}{4}$ - 20                        | 8        |
| 27   | 17-632          | Boom Hinge Complete                                       | 2        |
|      | HB-38-16-100    | Hex Bolt, $\frac{3}{8}$ - 16 x 1                          | 16       |
|      | HNFL-38-16      | Flange Whiz-loc Nut, $\frac{3}{8}$ - 16                   | 16       |
| 28   | 17-651          | Boom Center   | 1        |
| 29   | HB-516-18-075   | Hex Bolt, $\frac{5}{16}$ - 18 x $\frac{3}{4}$             | 8        |
|      | HW-516          | Flat Washer, $\frac{5}{16}$                               | 8        |
|      | HNFL-516-18     | Flange Whiz-loc Nut, $\frac{5}{16}$ - 18                  | 8        |

(Continue on next page)

# 17-580 20' BOOM DRAWING

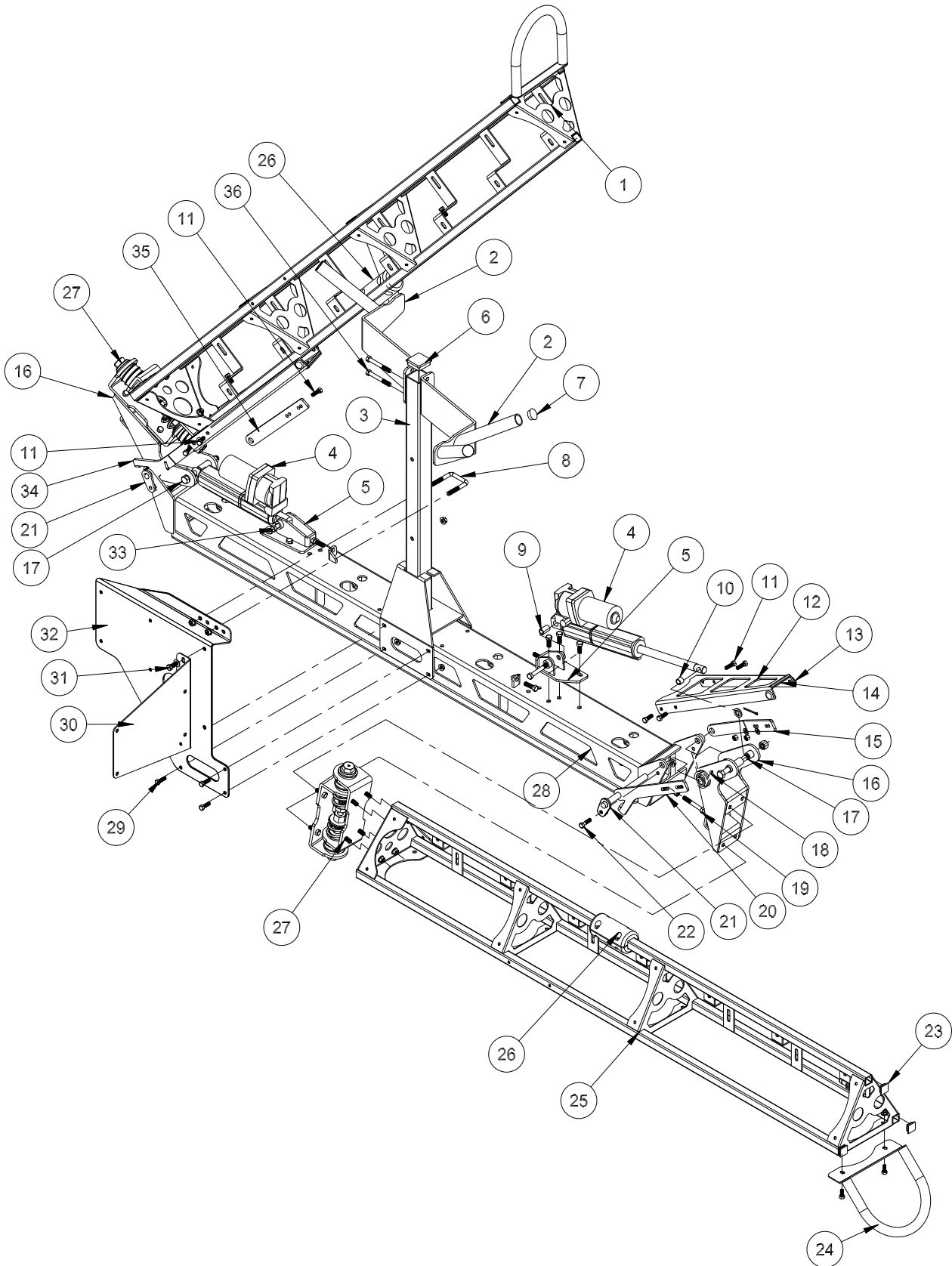

Accessories

## 17-580 20' BOOM PARTS LIST

| REF# | PART#        | DESCRIPTION                             | QUANTITY |
|------|--------------|---|----------|
| 30   | 17-636       | Fresh Water Tank Mount                  | 1        |
| 31   | HB-38-16-100 | Hex Bolt, $\frac{3}{8}$ - 16 x 1        | 2        |
|      | HNFL-38-16   | Flange Whiz-loc Nut, $\frac{3}{8}$ - 16 | 2        |
|      | HW-38        | Flat Washer, $\frac{3}{8}$              | 2        |
| 32   | 17-660       | Clean Load Mount                        | 1        |
|      | 8803-13      | Black Trim, 13"                         | 1        |
| 33   | HB-12-13-300 | Hex Bolt, $\frac{1}{2}$ - 13 x 3        | 2        |
|      | HNTL-12-13   | Nylon Lock Nut, $\frac{1}{2}$ - 13      | 2        |
| 34   | 17-593       | Limit Hinge, LH                         | 1        |
|      | 17-598       | Torsion Spring, LH                      | 1        |
| 35   | 17-592       | Lock Hinge, LH                          | 1        |
| 36   | HB-38-16-300 | Hex Bolt, $\frac{3}{8}$ - 16 x 3        | 2        |
|      | HNTL-38-16   | Nylon Lock Nut, $\frac{3}{8}$ - 16      | 2        |

## BOOM MOUNT TO TRUCK

| REF# | PART#        | DESCRIPTION                               | QUANTITY |
|------|--------------|---|----------|
| A    |              | Center Boom Mount                         | 1        |
| D    | HB-38-16-125 | Bolt, $\frac{3}{8}$ - 16 x $1\frac{1}{4}$ | 12       |
|      | HNFL-38-16   | Flange Lock Nut, $\frac{3}{8}$ -16        | 12       |
|      | HW-38        | Flat Washer, $\frac{3}{8}$                | 12       |
|      | HW-516       | Flat Washer, $\frac{5}{16}$               | 12       |

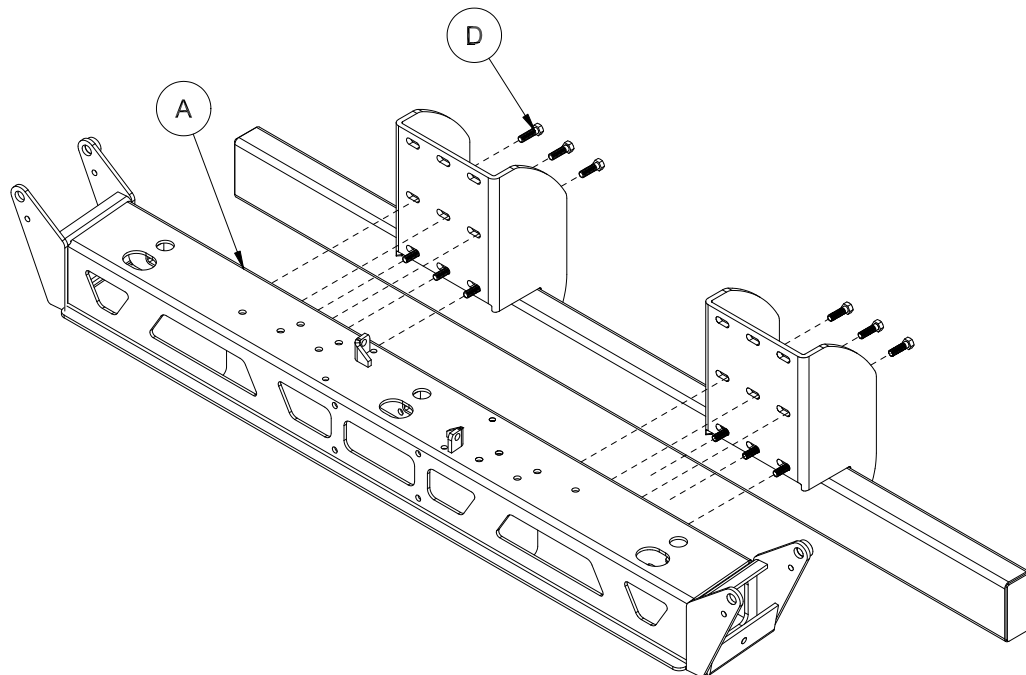

# 17-580 20' HD BOOM 1202/1204 PLUMBING

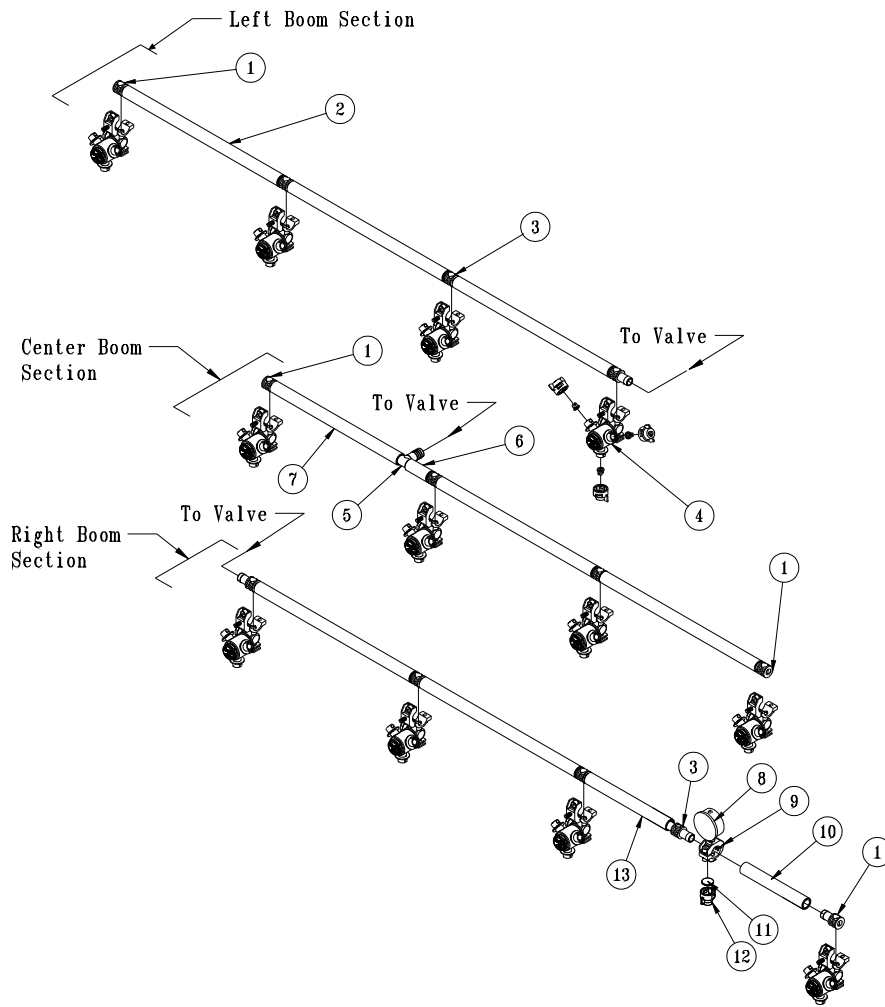

| REF# | PART#     | DESCRIPTION                                     | QUANTITY |
|------|-----------|---|----------|
| 1    | 18-417    | Single Barb                                     | 4        |
| 2    | 9032-19   | Black Hose, $\frac{3}{4}$ " x 19"               | 7        |
|      | 18-040    | Hose Clamp                                      | 14       |
| 3    | 18-416    | Double Barb                                     | 9        |
| 4    | 33-563    | Nozzle body (see nozzle drawing)                | 12       |
| 5    | 18-415    | $\frac{3}{4}$ " Hose Barb                       | 1        |
| 6    | 9032-2.5  | Black Hose $\frac{3}{4}$ " x 2 $\frac{1}{2}$ "  | 1        |
|      | 18-040    | Hose Clamp                                      | 2        |
| 7    | 9032-15.5 | Black Hose $\frac{3}{4}$ " x 15 $\frac{1}{2}$ " | 1        |
|      | 18-040    | Hose Clamp                                      | 2        |
| 8    | 16-281    | Gauge   | 1        |
| 9    | 17-602    | Nozzle Body                                     | 1        |
| 10   | 9032-5    | Black Hose $\frac{3}{4}$ " x 5"                 | 1        |
|      | 18-040    | Hose Clamp                                      | 2        |
| 11   | 16-800    | Gasket  | 1        |
| 12   | 16-921    | Cap   | 1        |
| 13   | 9032-13   | Black Hose $\frac{3}{4}$ " x 13"                | 1        |
|      | 18-040    | Hose Clamp                                      | 2        |



# 17-580 20' HD BOOM 1207 PLUMBING

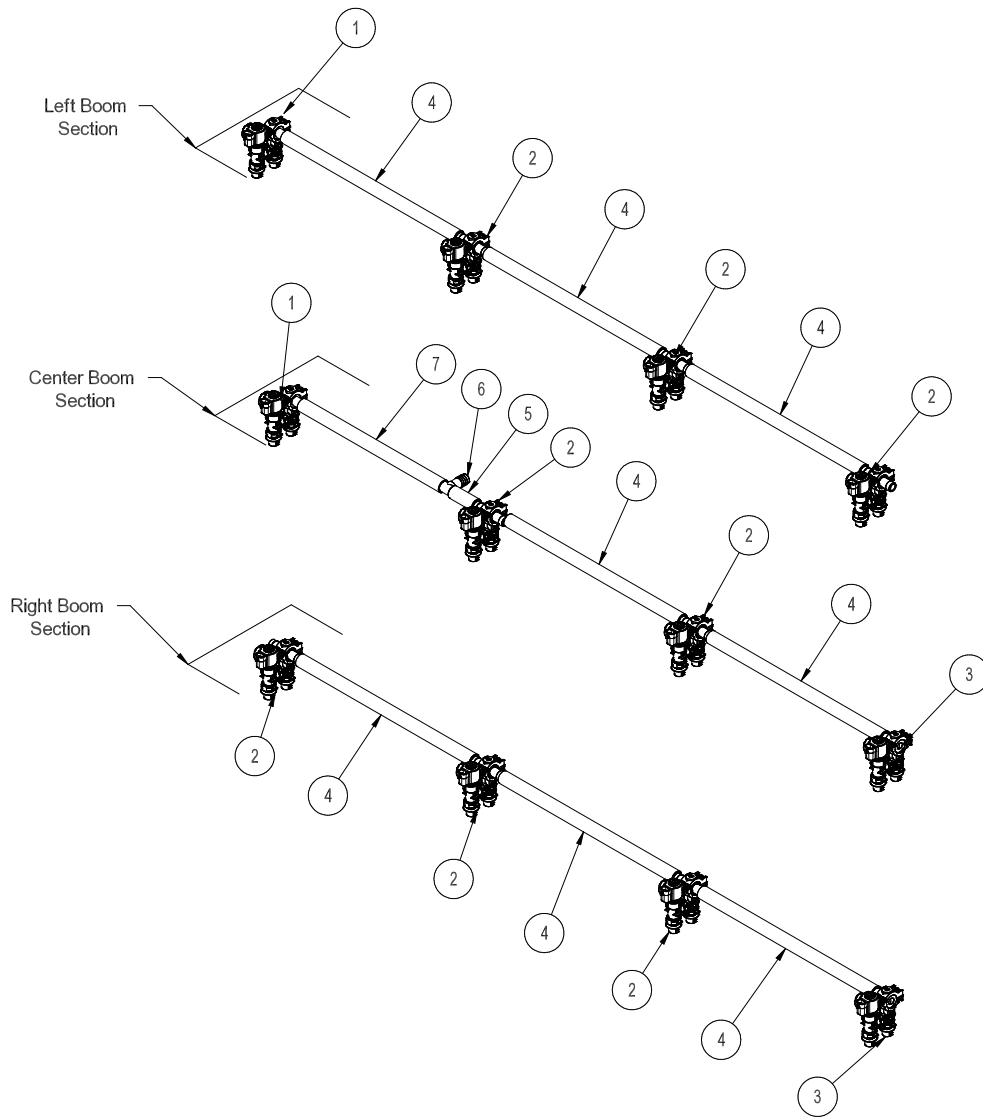

| REF# | PART#     | DESCRIPTION                                      | QUANTITY |
|------|-----------|--|----------|
| 1    | 20-675    | Single Hose Barb - Right Orientation             | 2        |
| 2    | 20-673    | Single Hose Barb                                 | 8        |
| 3    | 20-674    | Single Hose Barb - Left Orientation              | 2        |
| 4    | 9032-19   | Black Hose, $\frac{3}{4}$ " x 19"                | 8        |
|      | 18-040    | Hose Clamp                                       | 16       |
| 5    | 9032-2.5  | Black Hose, $\frac{3}{4}$ " x 2 $\frac{1}{2}$ "  | 1        |
|      | 18-040    | Hose Clamp                                       | 2        |
| 6    | 18-415    | $\frac{3}{4}$ " Hose Barb                        | 1        |
| 7    | 9032-15.5 | Black Hose, $\frac{3}{4}$ " x 15 $\frac{1}{2}$ " | 1        |
|      | 18-040    | Hose Clamp                                       | 2        |

# 17-580 20' HD BOOM 1220 PLUMBING

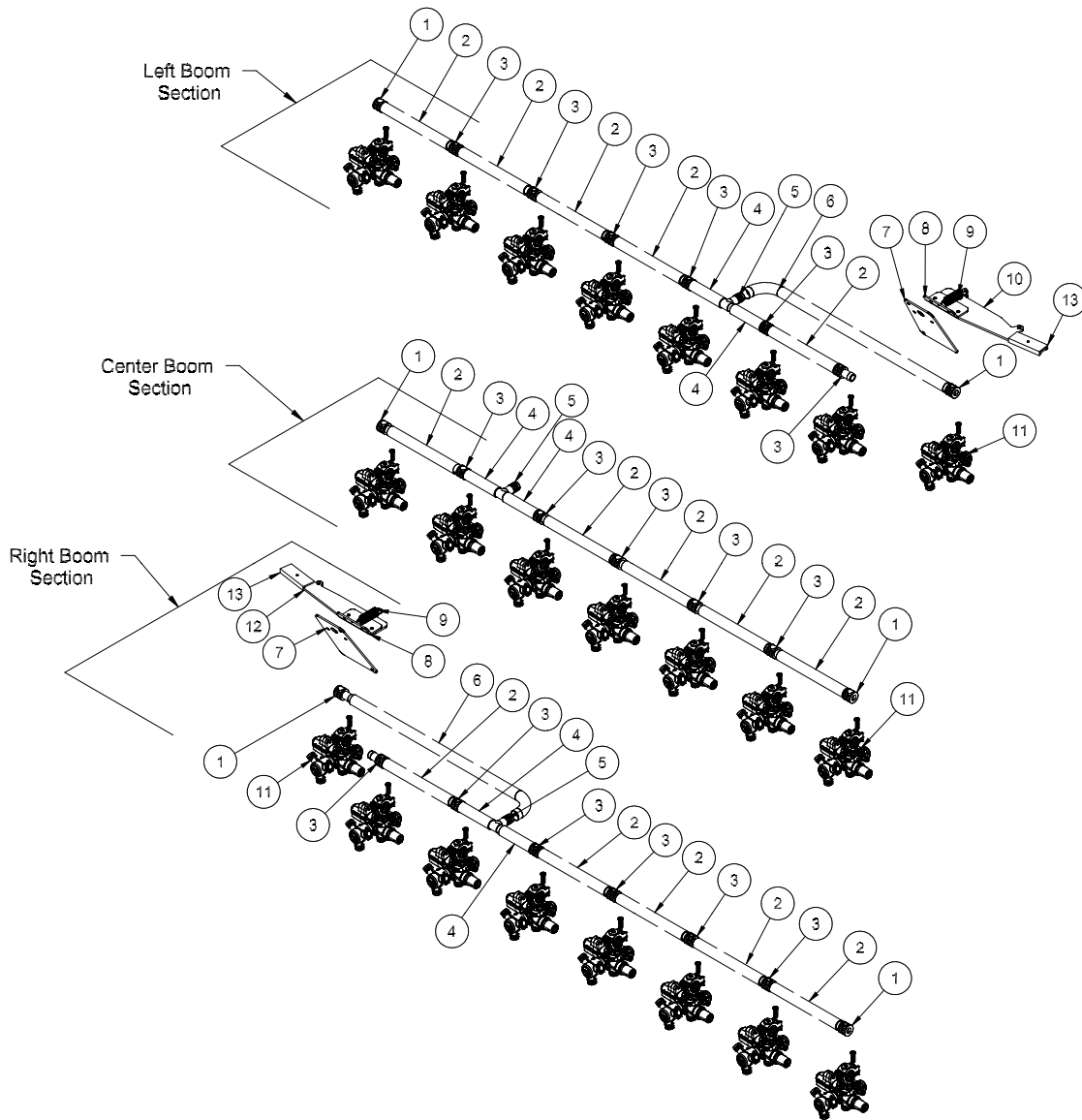

| REF# | PART#       | DESCRIPTION                                     | QUANTITY |
|------|-------------|---|----------|
| 1    | 18-417      | Single Barb                                     | 6        |
| 2    | 9032-8.5    | Black Hose, $\frac{3}{4}$ " x 8.5"              | 15       |
|      | 18-040      | Hose Clamp                                      | 30       |
| 3    | 18-416      | Double Barb                                     | 17       |
| 4    | 9032-4      | Black Hose $\frac{3}{4}$ " x 4"                 | 6        |
|      | 18-040      | Hose Clamp                                      | 12       |
| 5    | 18-415      | $\frac{3}{4}$ " Hose Barb                       | 3        |
| 6    | 9032-28     | Black Hose $\frac{3}{4}$ " x 15 $\frac{1}{2}$ " | 2        |
|      | 18-040      | Hose Clamp                                      | 4        |
| 7    | 17-559      | Break-Away Mount                                | 2        |
| 8    | 17-560      | Hinge Mount                                     | 2        |
| 9    | 11-050      | Spring  | 2        |
| 10   | 17-562      | LH Break-Away Arm                               | 1        |
| 11   | 20-807      | Nozzle Body                                     | 23       |
| 12   | 17-561      | RH Break-Away Arm                               | 1        |
| 13   | 8946-3.5    | Plastic Wear Strip                              | 2        |
|      | HRS-316-050 | Rivet, $\frac{3}{16}$ x $\frac{1}{2}$           | 2        |

# 17-585 18' HD BOOM 1218 PLUMBING

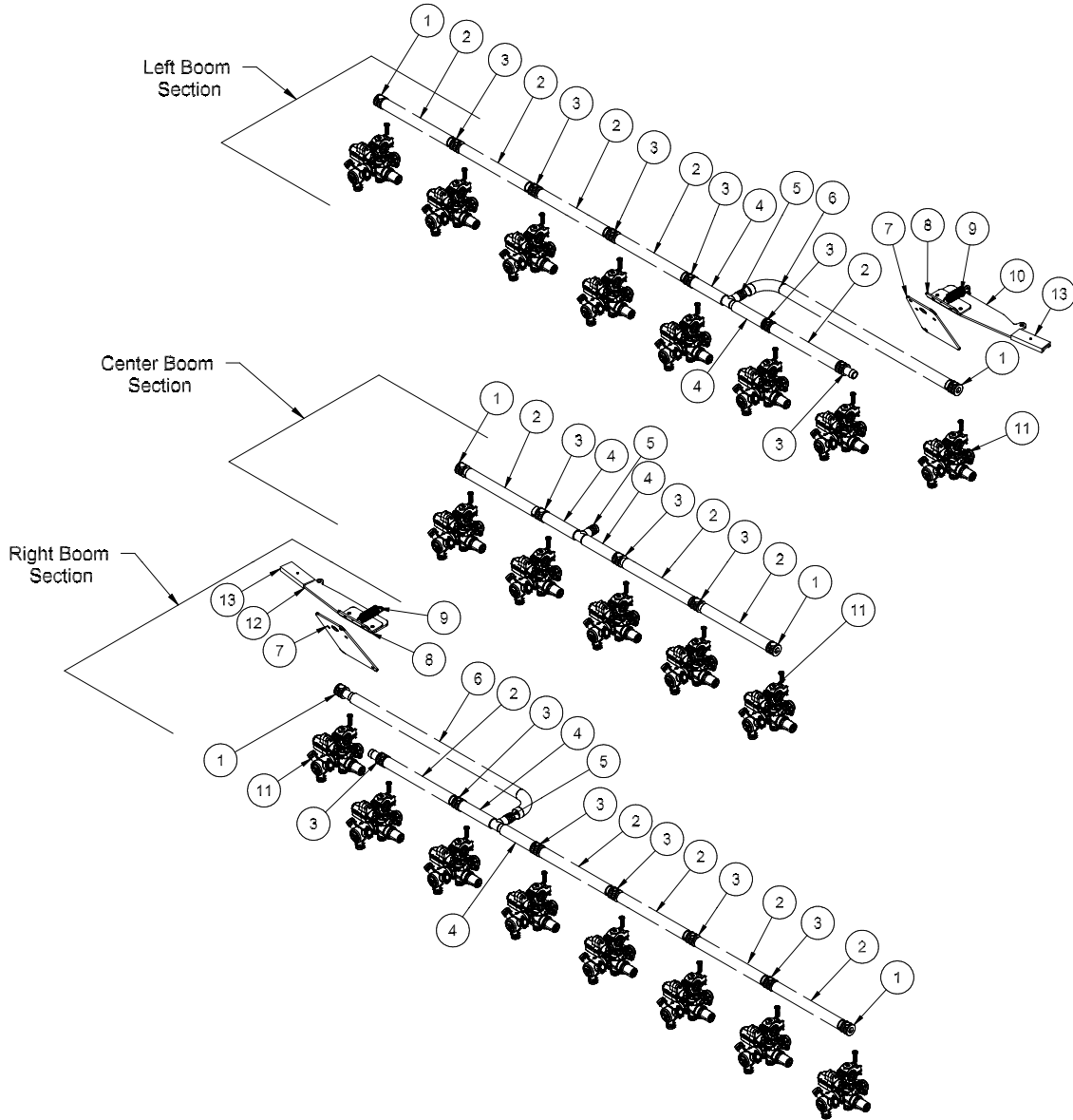

| REF# | PART#       | DESCRIPTION                                     | QUANTITY |
|------|-------------|---|----------|
| 1    | 18-417      | Single Barb                                     | 6        |
| 2    | 9032-8.5    | Black Hose, $\frac{3}{4}$ " x 8.5"              | 13       |
|      | 18-040      | Hose Clamp                                      | 26       |
| 3    | 18-416      | Double Barb                                     | 15       |
| 4    | 9032-4      | Black Hose $\frac{3}{4}$ " x 4"                 | 6        |
|      | 18-040      | Hose Clamp                                      | 12       |
| 5    | 18-415      | $\frac{3}{4}$ " Hose Barb                       | 3        |
| 6    | 9032-28     | Black Hose $\frac{3}{4}$ " x 15 $\frac{1}{2}$ " | 2        |
|      | 18-040      | Hose Clamp                                      | 4        |
| 7    | 17-559      | Break-Away Mount                                | 2        |
| 8    | 17-560      | Hinge Mount                                     | 2        |
| 9    | 11-050      | Spring  | 2        |
| 10   | 17-562      | LH Break-Away Arm                               | 1        |
| 11   | 20-807      | Nozzle Body                                     | 21       |
| 12   | 17-561      | RH Break-Away Arm                               | 1        |
| 13   | 8946-3.5    | Plastic Wear Strip                              | 2        |
|      | HRS-316-050 | Rivet, $\frac{3}{16}$ x $\frac{1}{2}$           | 2        |

# 17-585 18' HD BOOM DRAWING

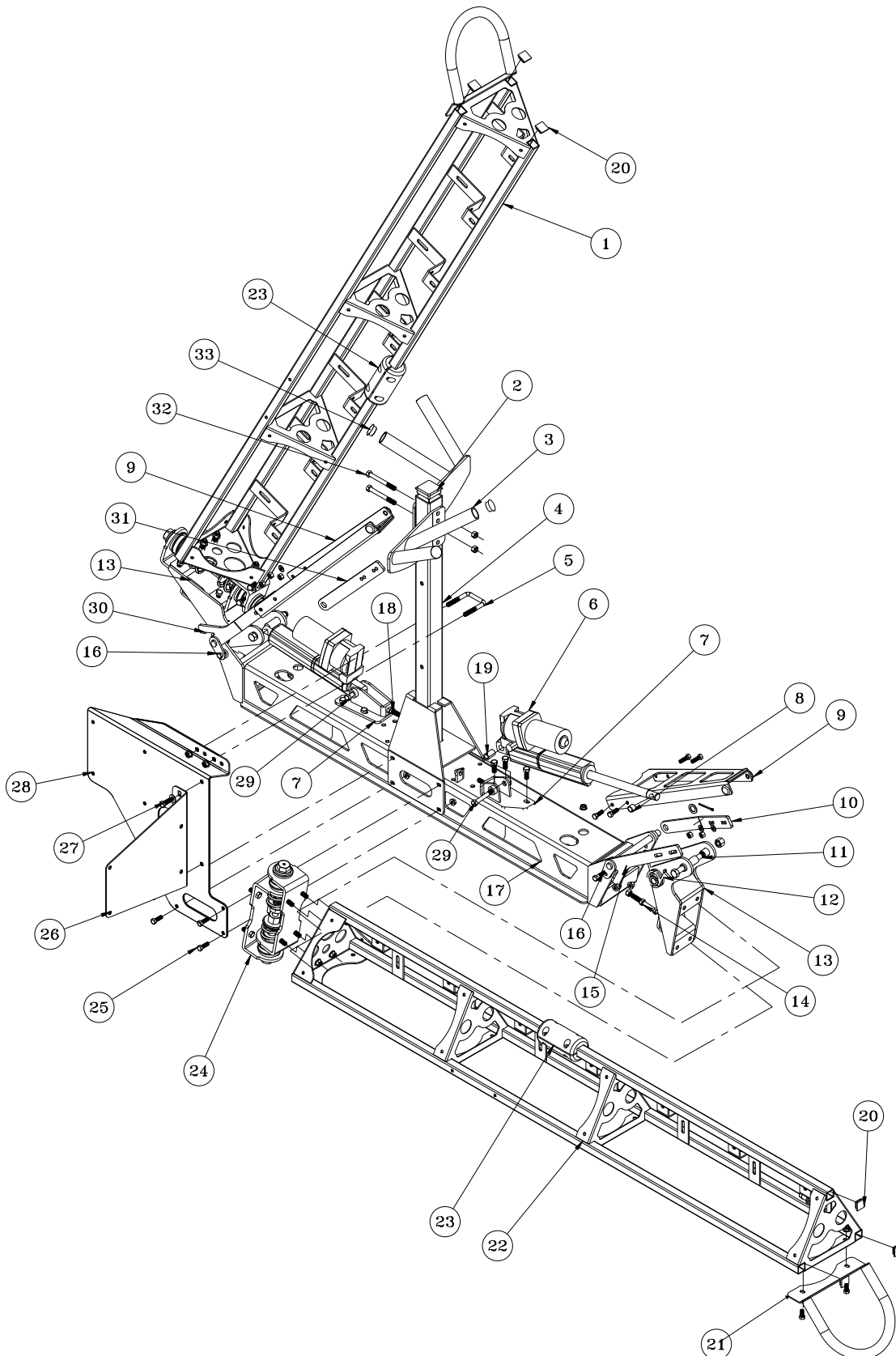

Accessories

# 17-585 18' HD BOOM PARTS LIST

| REF# | PART#           | DESCRIPTION   | QUANTITY |
|------|-----------------|---|----------|
| 1    | 17-652          | Left Boom Arm   | 1        |
| 2    | 18-297          | Cap Plug  | 1        |
| 3    | 17-617          | Boom Nest   | 2        |
| 4    | 17-578          | Boom Nest Post  | 1        |
| 5    | 17-537          | Square U-Hex Bolt                                       | 1        |
| 6    | 30-214          | KYB Electric/ Hydraulic Actuator (includes * items)     | 2        |
| 7    | 30-184          | Ram Mount   | 2        |
|      | HN-38-16        | Hex Nut, $\frac{3}{8}$ - 16 ( for adjustment Hex Bolts) | 4        |
|      | HB-38-16-100    | Hex Bolt, $\frac{3}{8}$ - 16 x 1                        | 6        |
|      | HW-38           | Flat Washer, $\frac{3}{8}$                              | 6        |
|      | HNFL-38-16      | Flange Whiz-loc Nut, $\frac{3}{8}$ -16                  | 6        |
| 8*   | 18-036          | $\frac{1}{2}$ " Bushing (part of 30-214)                | 2        |
| 9    | 32-564          | Boom Lock   | 2        |
|      | HB-516-18-100   | Hex Bolt, $\frac{5}{16}$ - 18 x 1                       | 8        |
|      | HW-516          | Flat Washer, $\frac{5}{16}$                             | 4        |
|      | HNTL-516-18     | Nylon Lock Nut, $\frac{5}{16}$ -18                      | 8        |
|      | 42-116          | Rubber Insert   | 4        |
|      | 8803-2.75       | Trim Lace, 2.75"  | 2        |
| 10   | 17-588          | Lock Hinge, RH  | 1        |
| 11   | HB-12-13-500    | Hex Bolt, $\frac{1}{2}$ - 13 x 5                        | 2        |
|      | HNTL-12-13      | Nylon Lock Nut, $\frac{1}{2}$ - 13                      | 2        |
| 12   | 17-597          | Torsion Spring, RH                                      | 1        |
| 13   | 30-185          | Arm Pivot Hinge   | 2        |
|      | HG-14-28-180    | Grease Fitting, $\frac{1}{4}$ - 28 x 180°               | 2        |
|      | 76-128          | Bushing (part of 30-185)                                | 4        |
| 14   | HB-38-16-175    | Hex Bolt, $\frac{3}{8}$ - 16 x $1\frac{3}{4}$           | 2        |
|      | HNFL-38-16      | Flange Whiz-loc Nut, $\frac{3}{8}$ - 16                 | 4        |
| 15   | 17-589          | Limit Hinge, RH   | 1        |
| 16   | 17-596          | Hinge Pin w/ Spacer                                     | 2        |
|      | HP-18-100       | Cotter Pin $\frac{1}{8}$ x 1                            | 2        |
|      | HB-516-18-100   | Hex Bolt, $\frac{5}{16}$ - 18 x 1                       | 2        |
|      | HNFL-516-18     | Flange Whiz-loc Nut, $\frac{5}{16}$ -18                 | 2        |
| 17   | 17-650          | Boom Center   | 1        |
| 18   | HB-38-16-100    | Hex Bolt, $\frac{3}{8}$ - 16 x 1                        | 2        |
|      | HNFL-38-16      | Hex Nut, $\frac{3}{8}$ - 16                             | 4        |
| 19*  | 18-234          | 1" Bushing (part of 30-214)                             | 2        |
| 20   | 30-258          | Ribbed 1" Plug  | 10       |
| 21   | 17-541          | Boom End Guard  | 2        |
|      | HBFL-516-18-075 | Hex Bolt, $\frac{5}{16}$ - 18 x $\frac{3}{4}$           | 4        |
|      | HNFL-516-18     | Flange Whiz-loc Nut, $\frac{5}{16}$ - 18                | 4        |
| 22   | 17-653          | Right Boom Arm  | 1        |
| 23   | 17-573          | Guide Block Set   | 2        |
|      | HB-14-20-125    | Hex Bolt, $\frac{1}{4}$ - 20 x $1\frac{1}{4}$           | 8        |
|      | HNTL-14-20      | Nylon Lock Nut, $\frac{1}{4}$ - 20                      | 8        |
| 24   | 17-632          | Boom Hinge Complete                                     | 2        |
|      | HB-38-16-100    | Hex Bolt, $\frac{3}{8}$ - 16 x 1                        | 16       |
|      | HNFL-38-16      | Flange Whiz-loc Nut, $\frac{3}{8}$ - 16                 | 16       |
| 25   | HB-516-18-100   | Hex Bolt, $\frac{5}{16}$ - 18 x 1                       | 8        |
|      | HW-516          | Flat Washer, $\frac{5}{16}$                             | 8        |
|      | HNFL-516-18     | Flange Whiz-loc Nut, $\frac{5}{16}$ - 18                | 8        |

(Continue on next page)

# 17-585 18' HD BOOM DRAWING

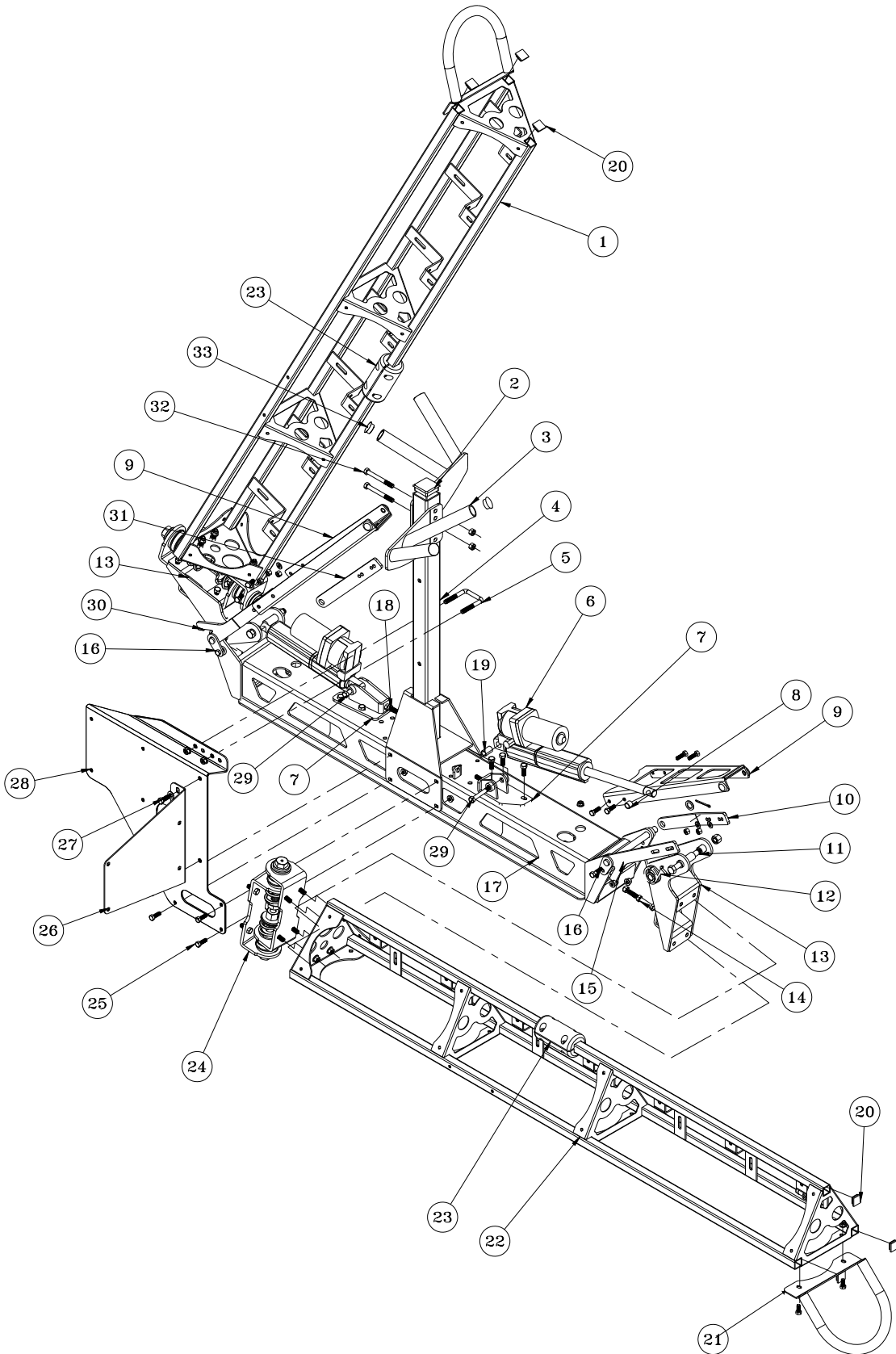

Accessories

## 17-585 18' HD BOOM PARTS LIST

| REF# | PART#        | DESCRIPTION                             | QUANTITY |
|------|--------------|---|----------|
| 26   | 17-636       | Fresh Water Tank Mount                  | 1        |
| 27   | HB-38-16-100 | Hex Bolt, $\frac{3}{8}$ - 16 x 1        | 2        |
|      | HNFL-38-16   | Flange Whiz-loc Nut, $\frac{3}{8}$ - 16 | 2        |
|      | HW-38        | Flat Washer, $\frac{3}{8}$              | 2        |
| 28   | 17-660       | Clean Load Mount                        | 1        |
|      | 8803-13      | Black Trim x 13"                        | 1        |
| 29   | HB-12-13-300 | Hex Bolt, $\frac{1}{2}$ - 13 x 3        | 2        |
|      | HNTL-12-13   | Nylon Lock Nut, $\frac{1}{2}$ - 13      | 2        |
| 30   | 17-593       | Limit Hinge, LH                         | 1        |
|      | 17-598       | Torsion Spring, LH                      | 1        |
| 31   | 17-592       | Lock Hinge, LH                          | 1        |
| 32   | HB-38-16-300 | Hex Bolt, $\frac{3}{8}$ - 16 x 3        | 2        |
|      | HNTL-38-16   | Nylon Lock Nut, $\frac{3}{8}$ - 16      | 2        |
| 33   | 17-619       | Tube Cap                                | 4        |

## BOOM MOUNT TO TRUCK

| REF# | PART#        | DESCRIPTION                               | QUANTITY |
|------|--------------|---|----------|
| A    |              | Center Boom Mount                         | 1        |
| D    | HB-38-16-125 | Bolt, $\frac{3}{8}$ - 16 x $1\frac{1}{4}$ | 12       |
|      | HNFL-38-16   | Flange Lock Nut, $\frac{3}{8}$ -16        | 12       |
|      | HW-38        | Flat Washer, $\frac{3}{8}$                | 12       |
|      | HW-516       | Flat Washer, $\frac{5}{16}$               | 12       |

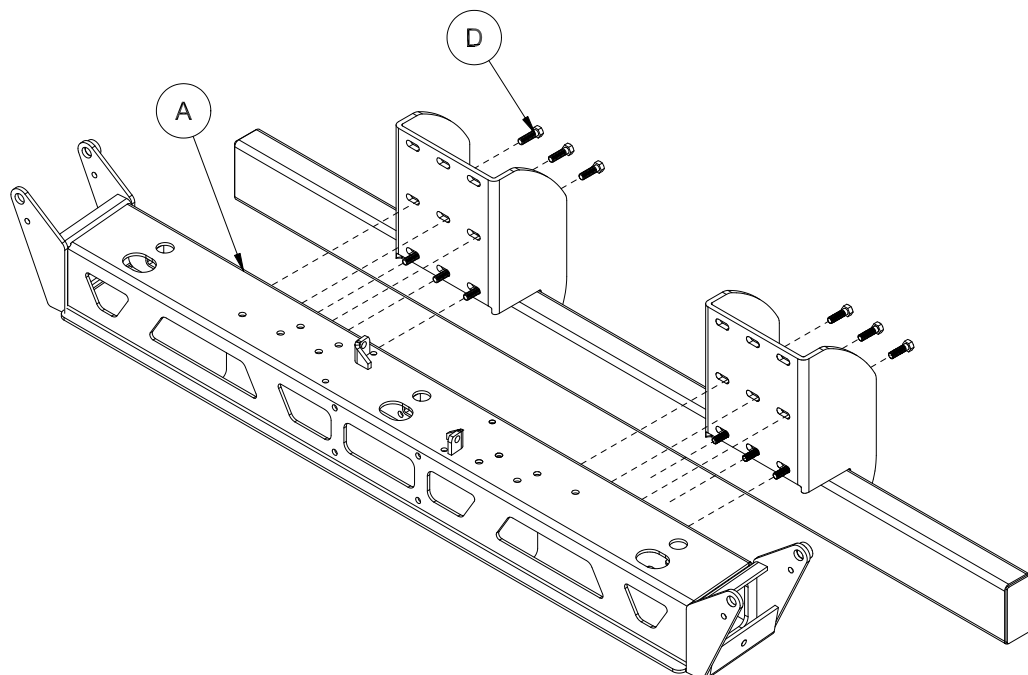

# 17-585 18' HD BOOM 1202/1204 PLUMBING

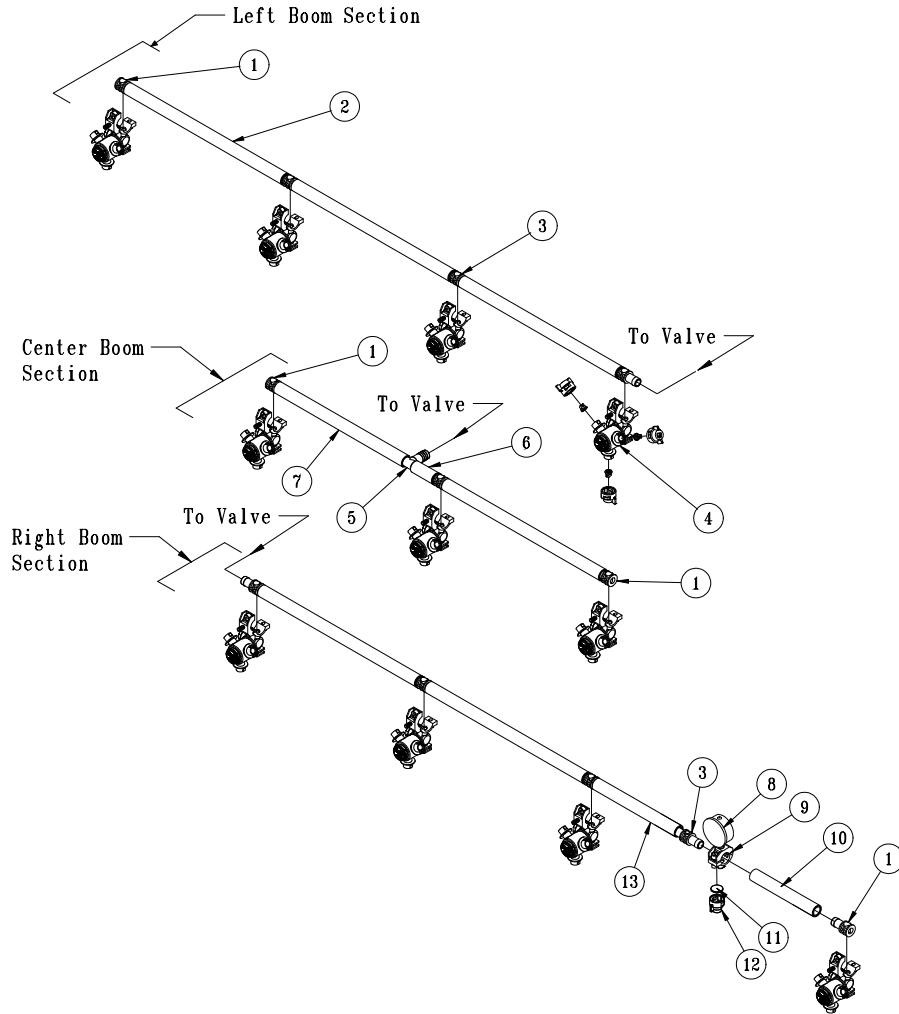

| REF# | PART#     | DESCRIPTION                      | QUANTITY |
|------|-----------|----------------------------------|----------|
| 1    | 18-417    | Single Barb                      | 4        |
| 2    | 9032-19   | Black Hose, 3/4" x 19"           | 6        |
|      | 18-040    | Hose Clamp                       | 12       |
| 3    | 18-416    | Double Barb                      | 8        |
| 4    | 33-563    | Nozzle body (see nozzle drawing) | 11       |
| 5    | 18-415    | 3/4" Hose Barb                   | 1        |
| 6    | 9032-2.5  | Black Hose, 3/4" x 2 1/2"        | 1        |
|      | 18-040    | Hose Clamp                       | 2        |
| 7    | 9032-15.5 | Black Hose, 3/4" x 15 1/2"       | 1        |
|      | 18-040    | Hose Clamp                       | 2        |
| 8    | 16-281    | Gauge                            | 1        |
| 9    | 17-602    | Nozzle Body                      | 1        |
| 10   | 9032-5    | Black Hose, 3/4" x 5"            | 1        |
|      | 18-040    | Hose Clamp                       | 2        |
| 11   | 16-800    | Gasket                           | 1        |
| 12   | 16-921    | Cap                              | 1        |
| 13   | 9032-13   | Black Hose, 3/4" x 13"           | 1        |
|      | 18-040    | Hose Clamp                       | 2        |



# 17-585 18' HD BOOM 1208 PLUMBING

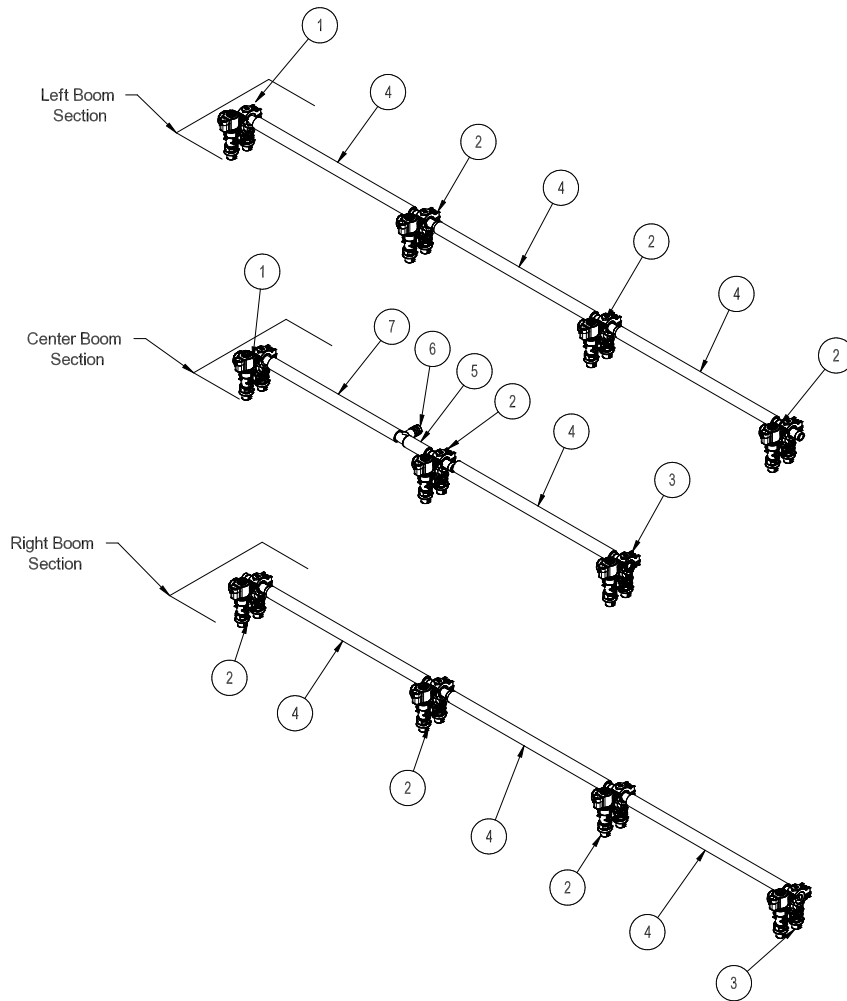

| REF# | PART#     | DESCRIPTION                                      | QUANTITY |
|------|-----------|--|----------|
| 1    | 20-675    | Single Hose Barb - Right Orientation             | 2        |
| 2    | 20-673    | Single Hose Barb                                 | 7        |
| 3    | 20-674    | Single Hose Barb - Left Orientation              | 2        |
| 4    | 9032-19   | Black Hose, $\frac{3}{4}$ " x 19"                | 7        |
|      | 18-040    | Hose Clamp                                       | 14       |
| 5    | 9032-2.5  | Black Hose, $\frac{3}{4}$ " x 2 $\frac{1}{2}$ "  | 1        |
|      | 18-040    | Hose Clamp                                       | 2        |
| 6    | 18-415    | $\frac{3}{4}$ " Hose Barb                        | 1        |
| 7    | 9032-15.5 | Black Hose, $\frac{3}{4}$ " x 15 $\frac{1}{2}$ " | 1        |
|      | 18-040    | Hose Clamp                                       | 2        |

Accessories

# 17-601 15' HD BOOM DRAWING

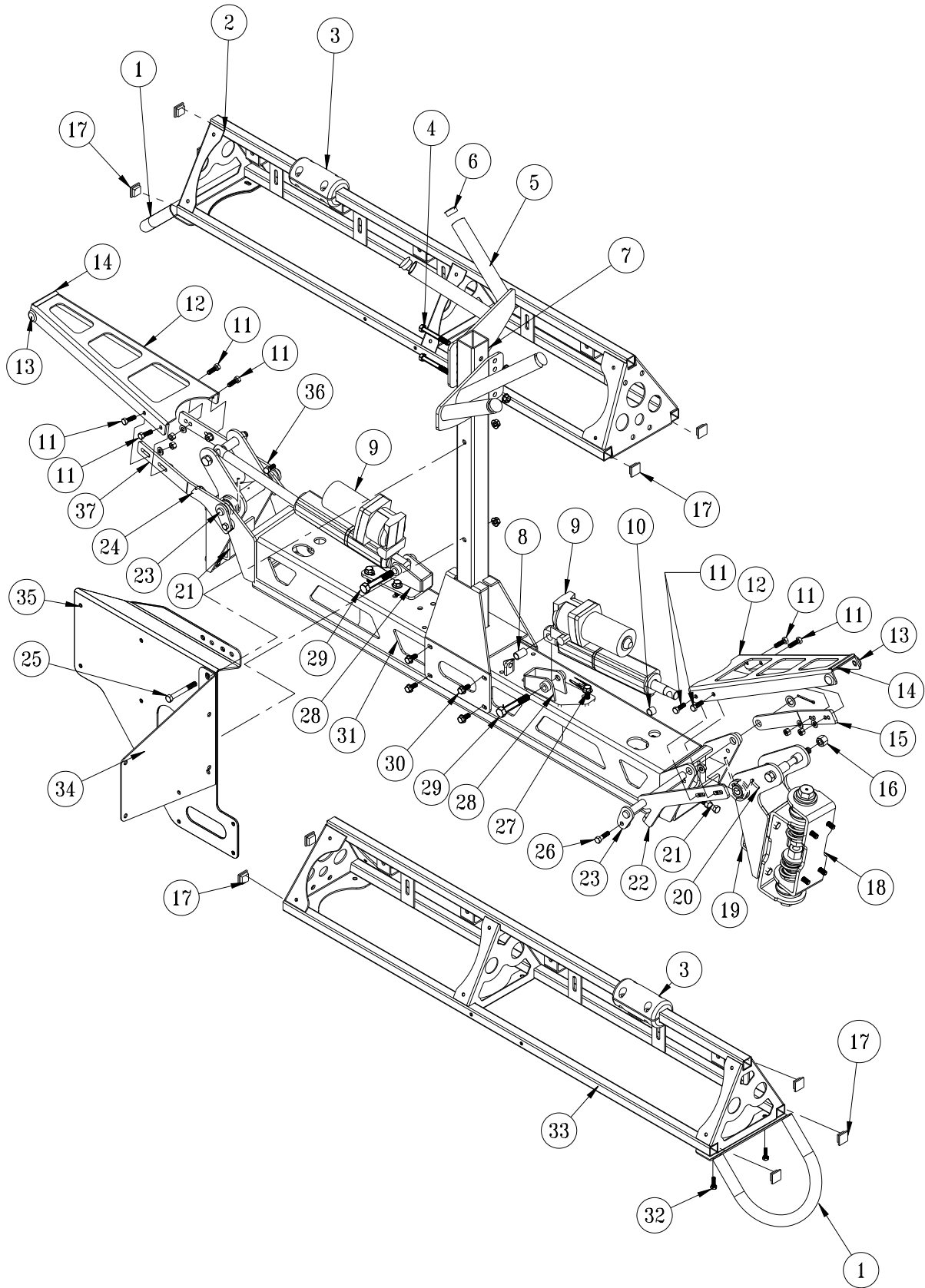

Accessories

# 17-601 15' HD BOOM PARTS LIST

| REF# | PART#         | DESCRIPTION                                  | QUANTITY |
|------|---------------|--|----------|
| 1    | 17-541        | Boom End Guard                               | 2        |
| 2    | 17-551        | Left Boom Arm                                | 1        |
| 3    | 17-573        | Guide Block Set                              | 2        |
|      | HB-14-20-125  | Bolt $\frac{1}{4}$ -20 x $1\frac{1}{4}$      | 8        |
|      | HNTL-14-20    | Lock Nut $\frac{1}{4}$ - 20                  | 8        |
| 4    | HB-38-16-300  | Bolt, $\frac{3}{8}$ - 16 x 3                 | 2        |
|      | HNTL-38-16    | Lock Nut, $\frac{3}{8}$ - 16                 | 2        |
| 5    | 17-617        | V-Boom Nest                                  | 2        |
| 6    | 17-619        | Push-In Rounds                               | 4        |
| 7    | 17-578        | Boom Nest Post                               | 1        |
|      | 18-297        | Cap Plug                                     | 1        |
| 8    | 18-036        | 1" Bushing (part of 30-214)                  | 2        |
| 9    | 30-214        | 10" Electric/Hydraulic Actuator              | 2        |
| 10   | 18-234        | $\frac{1}{2}$ " Bushing (part of 30-214)     | 2        |
| 11   | HB-516-18-100 | Bolt, $\frac{5}{16}$ -16 x 1                 | 8        |
|      | HW-516        | Flat Washer, $\frac{5}{16}$                  | 4        |
|      | HNTL-516-18   | Lock Nut, $\frac{5}{16}$ - 18                | 8        |
| 12   | 32-564        | Boom Lock                                    | 2        |
| 13   | 42-116        | Rubber Insert                                | 4        |
| 14   | 8803-2.75     | Trim Lace, $2\frac{3}{4}$                    | 2        |
| 15   | 17-588        | Lock Hinge, RH                               | 1        |
| 16   | HB-12-13-500  | Bolt, $\frac{1}{2}$ - 13 x 5                 | 2        |
|      | HNTL-12-13    | Lock Nut, $\frac{1}{2}$ -13                  | 2        |
| 17   | 30-258        | 1" 10-14ga Ribbed Plug                       | 10       |
| 18   | 17-632        | Boom Hinge Complete                          | 2        |
|      | HB-38-16-100  | Bolt, $\frac{3}{8}$ - 16 x 1                 | 16       |
|      | HNFL-38-16    | Lock Nut, $\frac{3}{8}$ - 16                 | 16       |
| 19   | 30-185        | Arm Pivot Hinge                              | 2        |
|      | HG-14-28-180  | Grease Fitting, $\frac{1}{4}$ - 28 x 180°    | 2        |
|      | 76-128        | Bushing (part of 30-185)                     | 4        |
| 20   | 17-597        | Torsion Spring, RH                           | 1        |
| 21   | HB-38-16-175  | Bolt, $\frac{3}{8}$ - 16 x $1\frac{3}{4}$    | 2        |
|      | HNFL-38-16    | Flange Lock Nut, $\frac{3}{8}$ - 16          | 4        |
| 22   | 17-589        | Limit Hinge, RH                              | 1        |
| 23   | 17-596        | Hinge Pin w/Spacer                           | 2        |
|      | HP-18-100     | Cotter Pin, $\frac{1}{8}$ x 1                | 2        |
| 24   | 17-598        | Torsion Spring, LH                           | 1        |
| 25   | HB-38-16-100  | Bolt, $\frac{3}{8}$ - 16 x 1                 | 2        |
|      | HW-38         | Washer, $\frac{3}{8}$                        | 2        |
|      | HNFL-38-16    | Flange Lock Nut, $\frac{3}{8}$ - 16          | 2        |
| 26   | HB-516-18-100 | Bolt, $\frac{5}{16}$ -16 x 1                 | 2        |
|      | HNFL-516-18   | Flange Lock Nut, $\frac{5}{16}$ - 18         | 2        |
| 27   | HB-38-16-100  | Bolt, $\frac{3}{8}$ - 16 x 1                 | 6        |
|      | HW-38         | Washer, $\frac{3}{8}$                        | 6        |
|      | HNFL-38-16    | Flange Lock Nut, $\frac{3}{8}$ -16           | 6        |
| 28   | 30-184        | Ram Mount                                    | 2        |
|      | HN-38-16      | Nut, $\frac{3}{8}$ - 16 (on adjustment nuts) | 4        |
| 29   | HB-12-13-300  | Bolt, $\frac{1}{2}$ - 13 x 3                 | 2        |
|      | HNTL-12-13    | Lock Nut, $\frac{1}{2}$ - 13                 | 2        |
| 30   | HB-516-18-100 | Bolt, $\frac{5}{16}$ - 18 x 1                | 8        |
|      | HW-516        | Washer, $\frac{5}{16}$                       | 8        |
|      | HNFL-516-18   | Flange Lock Nut, $\frac{5}{16}$ - 18         | 8        |

(Continued on next page)

# 17-601 15' HD BOOM DRAWING

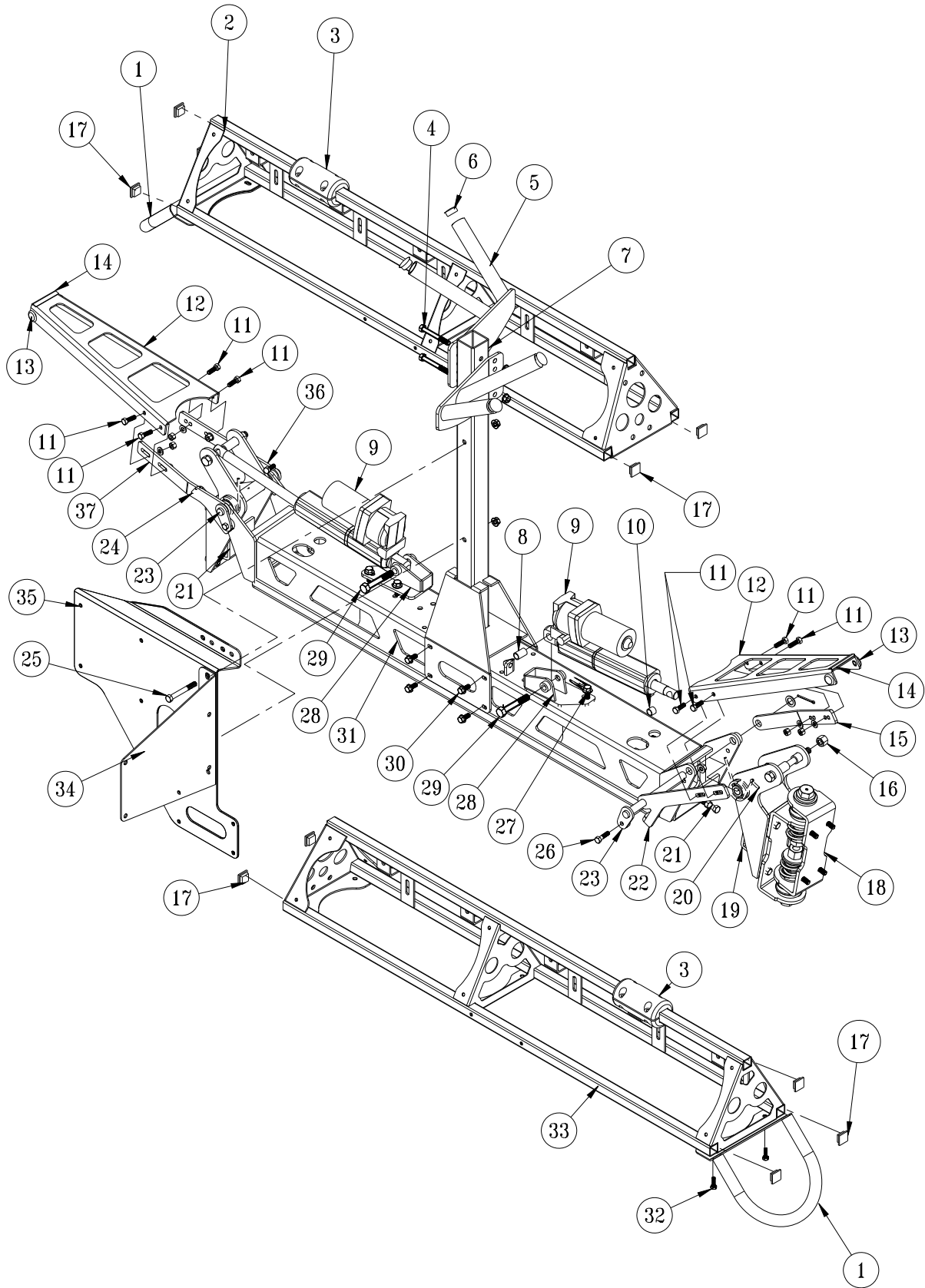

Accessories

## 17-601 15' HD BOOM PARTS LIST

| REF# | PART#           | DESCRIPTION                               | QUANTITY |
|------|-----------------|---|----------|
| 31   | 17-528          | Boom Center                               | 1        |
|      | 25-334          | Decal, Serial Tag                         | 1        |
| 32   | HBFL-516-18-075 | Bolt, $\frac{5}{16}$ - 18 x $\frac{3}{4}$ | 4        |
|      | HNFL-516-18     | Flange Lock Nut, $\frac{5}{16}$ - 18      | 4        |
| 33   | 17-552          | Right Boom Arm                            | 1        |
| 34   | 17-636          | Freshwater Mount                          | 1        |
| 35   | 17-660          | Clean Load Mount                          | 1        |
|      | 8803-13         | Black Trim, 13"                           |          |
| 36   | 17-592          | Lock Hinge, LH                            | 1        |
| 37   | 17-593          | Limit Hinge, LH                           | 1        |
| 38   | 17-537          | Square U-bolt                             | 1        |
|      | HNCL-34-10      | Center Lock Nut, $\frac{3}{4}$ -10        | 4        |
|      | HW-34           | Flat Washer, $\frac{3}{4}$                | 4        |

## BOOM MOUNT TO TRUCK

| REF# | PART#        | DESCRIPTION                               | QUANTITY |
|------|--------------|---|----------|
| A    |              | Center Boom Mount                         | 1        |
| D    | HB-38-16-125 | Bolt, $\frac{3}{8}$ - 16 x $1\frac{1}{4}$ | 12       |
|      | HNFL-38-16   | Flange Lock Nut, $\frac{3}{8}$ -16        | 12       |
|      | HW-38        | Flat Washer, $\frac{3}{8}$                | 12       |
|      | HW-516       | Flat Washer, $\frac{5}{16}$               | 12       |

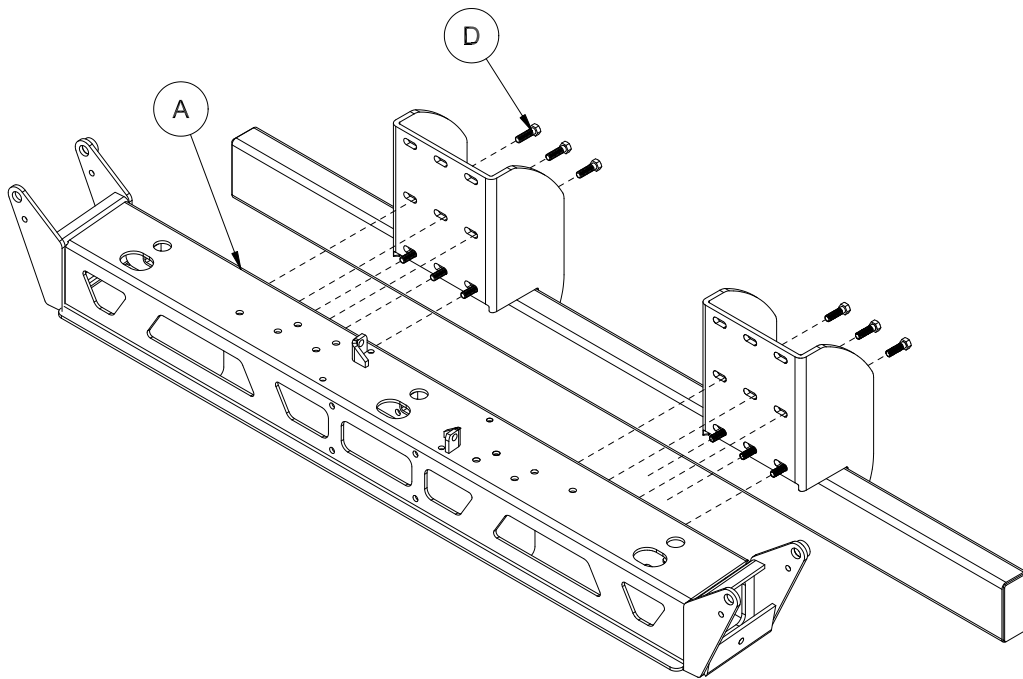

# 17-601 15' HD SUPER BOOM 1202/1204 PLUMBING

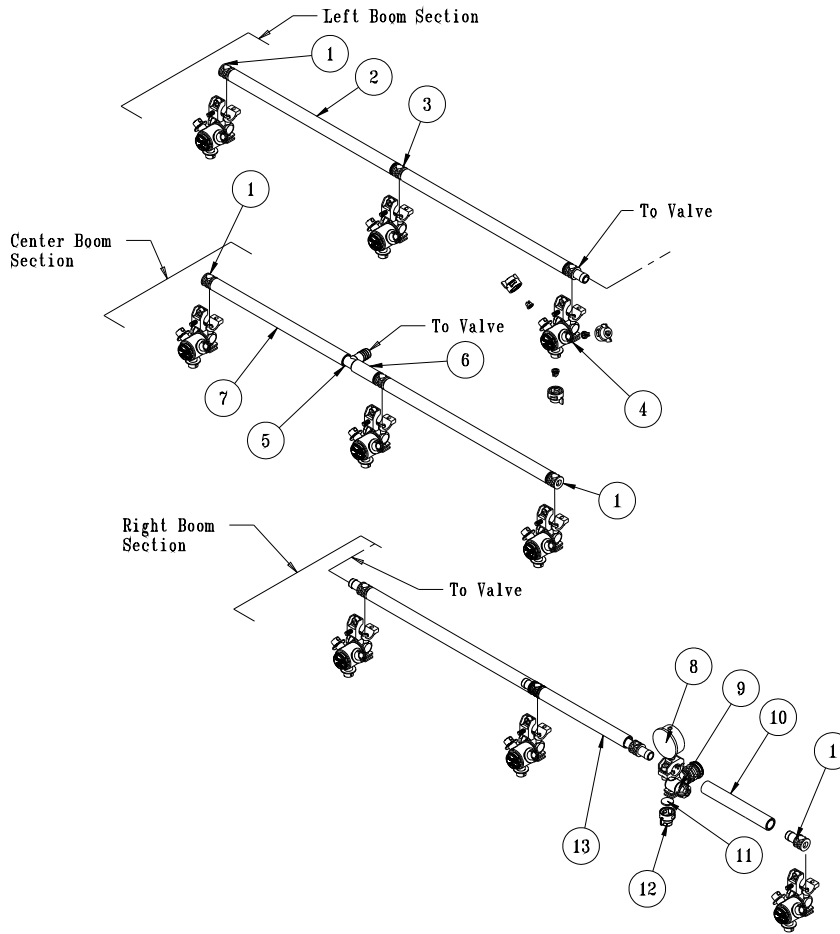

| REF# | PART#     | DESCRIPTION                                     | QUANTITY |
|------|-----------|---|----------|
| 1    | 18-417    | Single Barb                                     | 4        |
| 2    | 9032-19   | Black Hose $\frac{3}{4}$ " x 19"                | 4        |
|      | 18-040    | Hose Clamp                                      | 8        |
| 3    | 18-416    | Hose Clamp                                      | 6        |
| 4    | 33-563    | Double Barb                                     | 6        |
| 5    | 18-415    | Nozzle body (see nozzle drawing)                | 9        |
| 6    | 18-415    | $\frac{3}{4}$ " Hose Barb                       | 1        |
| 7    | 9032-2.5  | Black Hose $\frac{3}{4}$ " x 2 $\frac{1}{2}$ "  | 1        |
|      | 18-040    | Hose Clamp                                      | 2        |
| 8    | 9032-15.5 | Black Hose $\frac{3}{4}$ " x 15 $\frac{1}{2}$ " | 1        |
|      | 18-040    | Hose Clamp                                      | 2        |
| 9    | 16-281    | Gauge   | 1        |
| 10   | 17-602    | Nozzle Body                                     | 1        |
|      | 9032-5    | Black Hose $\frac{3}{4}$ " x 5"                 | 1        |
|      | 18-040    | Hose Clamp                                      | 2        |
| 11   | 16-800    | Gasket  | 1        |
| 12   | 16-921    | Cap   | 1        |
| 13   | 9032-13   | Black Hose $\frac{3}{4}$ " x 13"                | 1        |
|      | 18-040    | Hose Clamp                                      | 2        |

# 17-601 15' HD BOOM 1215 PLUMBING

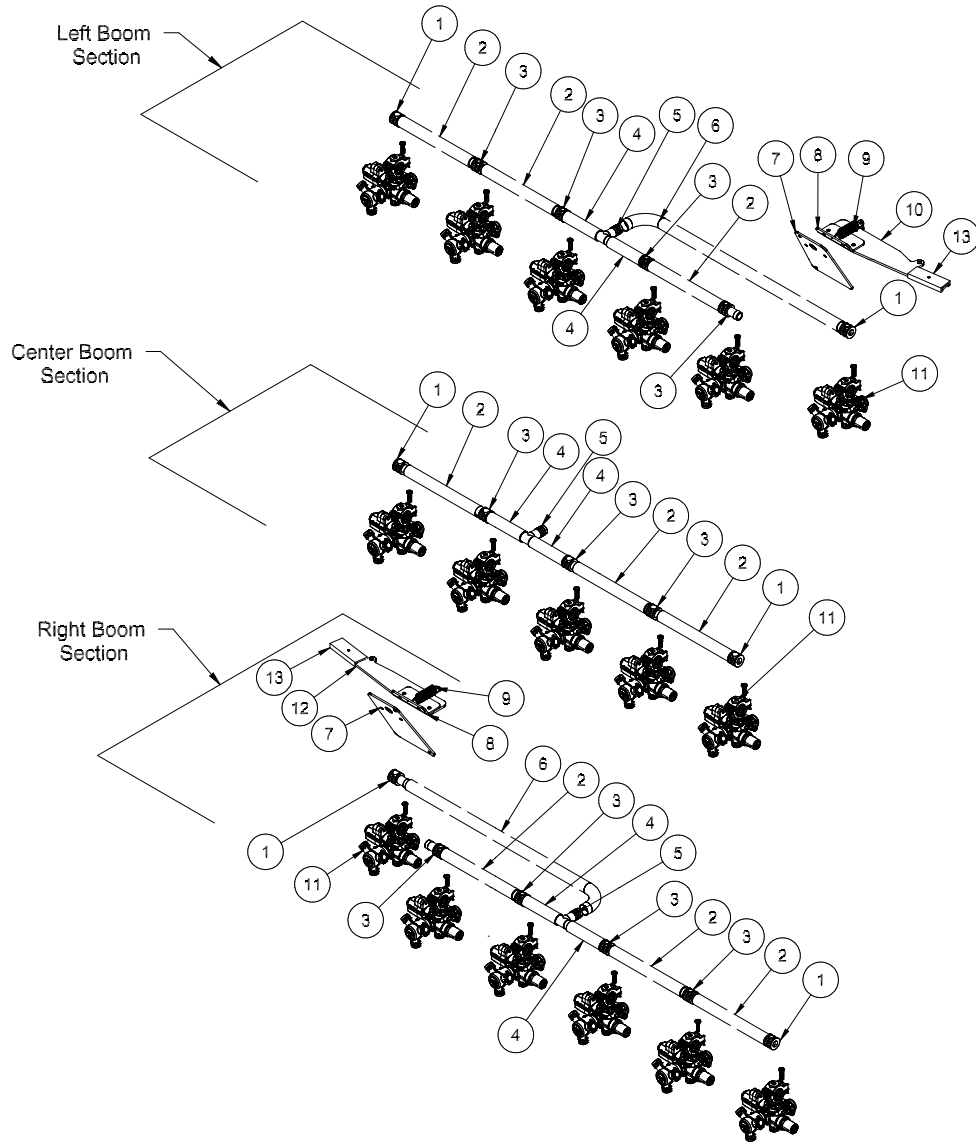

| REF# | PART#       | DESCRIPTION                                     | QUANTITY |
|------|-------------|---|----------|
| 1    | 18-417      | Single Barb                                     | 6        |
| 2    | 9032-8.5    | Black Hose, $\frac{3}{4}$ " x 8.5"              | 9        |
|      | 18-040      | Hose Clamp                                      | 18       |
| 3    | 18-416      | Double Barb                                     | 11       |
| 4    | 9032-4      | Black Hose $\frac{3}{4}$ " x 4"                 | 6        |
|      | 18-040      | Hose Clamp                                      | 12       |
| 5    | 18-415      | $\frac{3}{4}$ " Hose Barb                       | 3        |
| 6    | 9032-28     | Black Hose $\frac{3}{4}$ " x 15 $\frac{1}{2}$ " | 2        |
|      | 18-040      | Hose Clamp                                      | 4        |
| 7    | 17-559      | Break-Away Mount                                | 2        |
| 8    | 17-560      | Hinge Mount                                     | 2        |
| 9    | 11-050      | Spring  | 2        |
| 10   | 17-562      | LH Break-Away Arm                               | 1        |
| 11   | 20-807      | Nozzle Body                                     | 17       |
| 12   | 17-561      | RH Break-Away Arm                               | 1        |
| 13   | 8946-3.5    | Plastic Wear Strip                              | 2        |
|      | HRS-316-050 | Rivet, $\frac{3}{16}$ x $\frac{1}{2}$           | 2        |

# BOOM HINGE ASSEMBLED

## 2 HINGE ASSEMBLIES PER BOOM

\*17-632-K Boom Hinge Complete

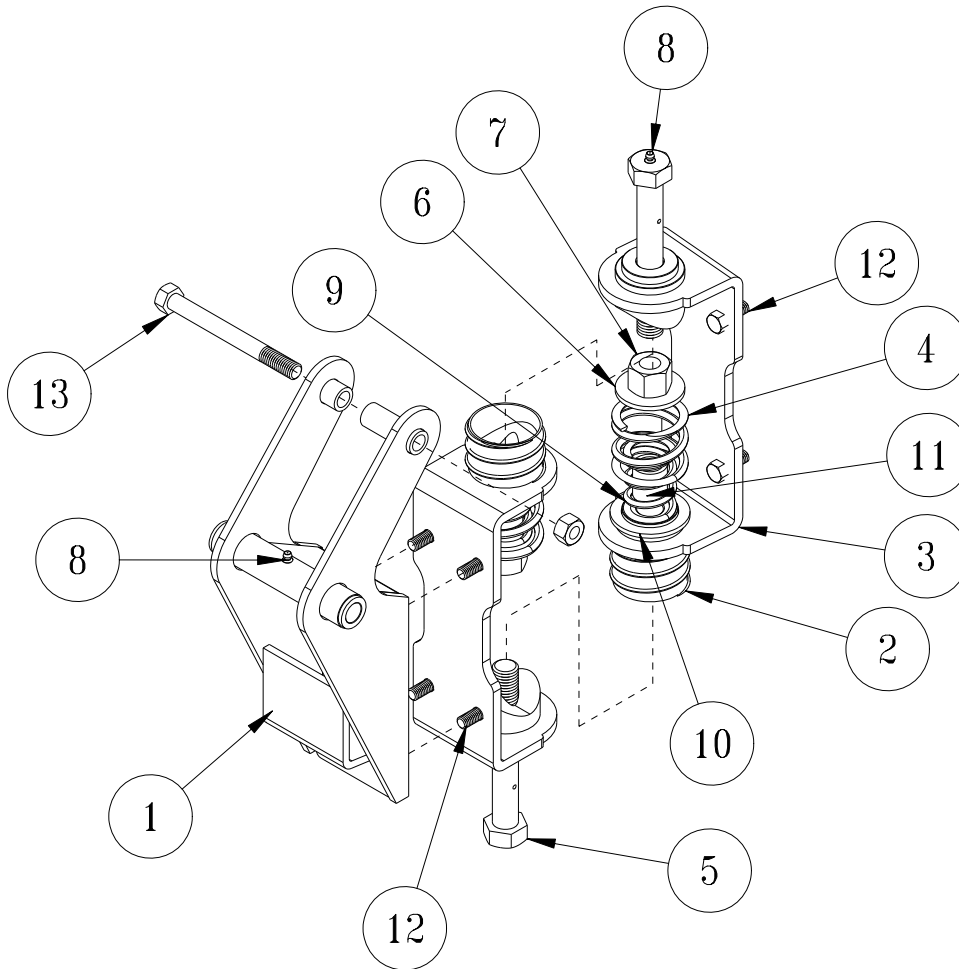

| REF# | PART#        | DESCRIPTION                    | QUANTITY |
|------|--------------|--------------------------------|----------|
| 1    | 30-185       | Arm Pivot Hinge (part of boom) | 1        |
|      | HG-14-28-180 | Grease Zerker (part of boom)   | 1        |
| 2*   | 9026-2       | Rubber Duct Hose, 2"           | 2        |
| 3*   | 17-527       | Boom Hinge                     | 1        |
| 4*   | 17-539       | Compression Spring             | 2        |
| 5*   | 17-540       | Tapped Bolt                    | 2        |
| 6*   | HW-34        | Flat Washer, 3/4               | 2        |
| 7*   | HNCL-34-10   | Center Lock Nut, 3/4 - 10      | 2        |
| 8*   | HG-14-28-180 | Grease Zerker                  | 2        |
| 9*   | 17-591       | Compression Spring             | 2        |
| 10*  | 17-599       | Spring Shim                    | 2        |
| 11*  | 17-594       | Spring Sleeve                  | 2        |
| 12*  | HB-38-16-100 | Hex Bolt, 3/8 - 16 x 1         | 8        |
|      | HNFL-38-16   | Flange Lock Nut, 3/8 - 16      | 8        |
| 13   | HB-12-13-500 | Hex Bolt, 1/2 - 13 x 5         | 1        |
|      | HNTL-12-13   | Lock Nut, 1/2 - 13             | 1        |



# 33-563 STANDARD NOZZLE ASSEMBLY

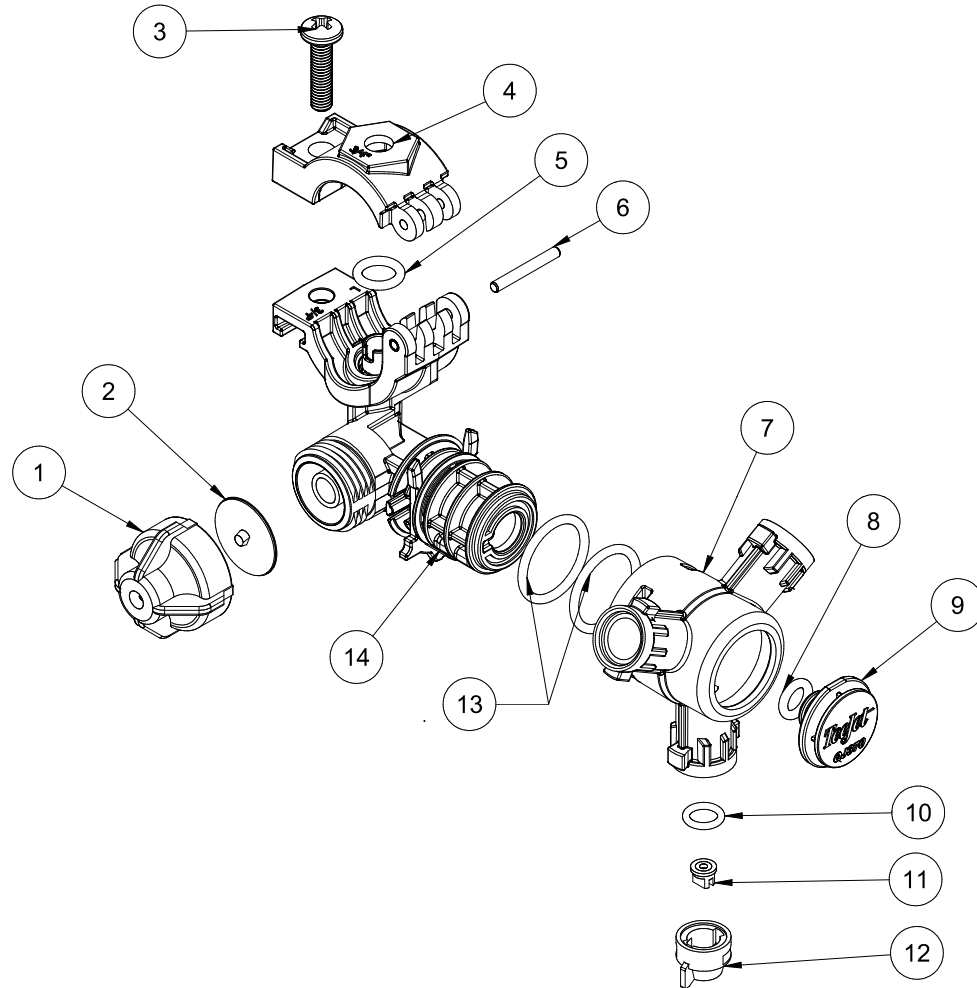

| REF# | PART#     | DESCRIPTION                        | QUANTITY |
|------|-----------|------------------------------------|----------|
| 1*   | 16-988    | Cap Assembly                       | 1        |
| 2*   | 16-920-06 | Diaphragm, EPDM                    | 1        |
| 3*   |           | Stainless Steel Screw              | 1        |
| 4*   |           | Upper Clamp                        | 1        |
| 5*   | 16-920-03 | O-ring                             | 1        |
| 6*   |           | Pivot Pin, Stainless Steel         | 1        |
| 7*   |           | Turret, 3-Outlet, Nylon            | 1        |
| 8*   |           | O-ring, EPDM                       | 1        |
| 9*   |           | Plug                               | 1        |
| 12   | 33-538    | Cap - White                        | 1        |
| 11   | 33-554    | Nozzle Tip - White (XR11008-VS)    | 1        |
| 10   | 16-800    | Viton Gasket                       | 1        |
| 13*  |           | O-ring, Teflon                     | 2        |
| 14*  | 33-563    | Nozzle Body (includes all * items) | 1        |

Quantity is per nozzle body. For 20' booms multiply quantity by 12.

Quantity is per nozzle body. For 18' booms multiply quantity by 11.

Quantity is per nozzle body. For 18' booms multiply quantity by 9.

Nozzles are located 20" (51 cm) apart on the right, left, and center tubes.

Nozzles are 20" high off ground.

# 1207D/1208D NOZZLE DRAWING

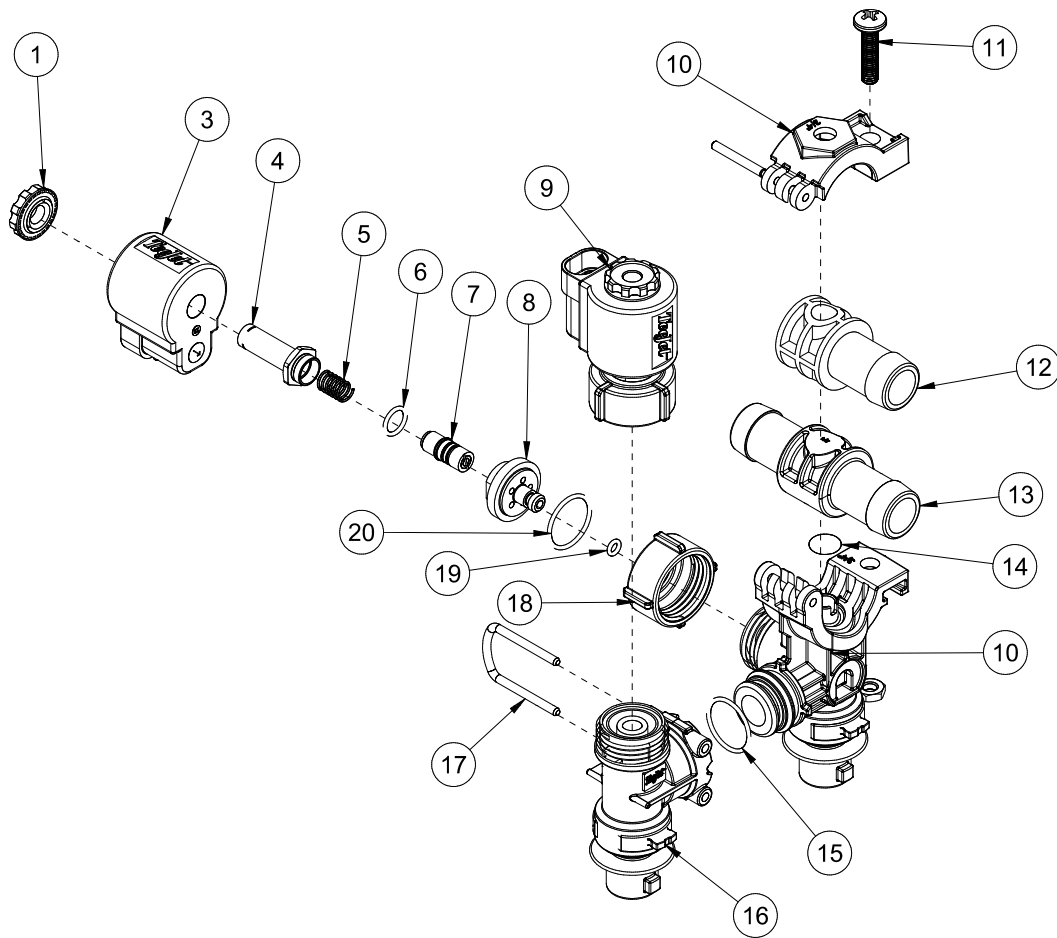

| REF# | PART#     | DESCRIPTION                                 | QUANTITY |
|------|-----------|---|----------|
| 1†   |           | Nylon Black Nut                             | 1        |
| 3    | 20-673-09 | 12V Coil Assembly                           | 1        |
| 4†   |           | Tube Sub Assembly                           | 1        |
| 5*†  |           | 302 Stainless Steel Spring                  | 1        |
| 6*†  |           | Viton O-ring                                | 1        |
| 7*†  |           | Plunger                                     | 1        |
| 8†   |           | 303 Stainless Steel Cap                     | 1        |
| 9    | 20-673-02 | E-Chemsaver Solenoid                        | 1        |
| 10   | 20-673-04 | 3/4" Mount Assembly                         | 1        |
| 11   |           | Pan Head Screw                              | 1        |
| 12   | 18-417    | Single Barb (part of 20-674-P and 20-675-P) | 1        |
| 13   | 18-416    | Double Barb (part of 20-673-P)              | 1        |
| 14   | 16-920-03 | O-ring                                      | 1        |
| 15   | 20-673-11 | O-ring                                      | 1        |
| 16   | 20-673-05 | End Body Sub-assembly                       | 1        |
| 17   | 20-673-08 | Retaining Clip                              | 1        |
| 18   |           | Locking Ring                                | 1        |
| 19*† | 20-673-07 | Viton O-ring                                | 1        |
| 20*† | 20-673-06 | Viton Gasket                                | 1        |
| *    | 20-673-01 | Spare Parts Kit                             |          |
| †    | 20-673-12 | Field Repair Kit                            |          |

Accessories

# 1207D/1208D NOZZLE ASSEMBLY

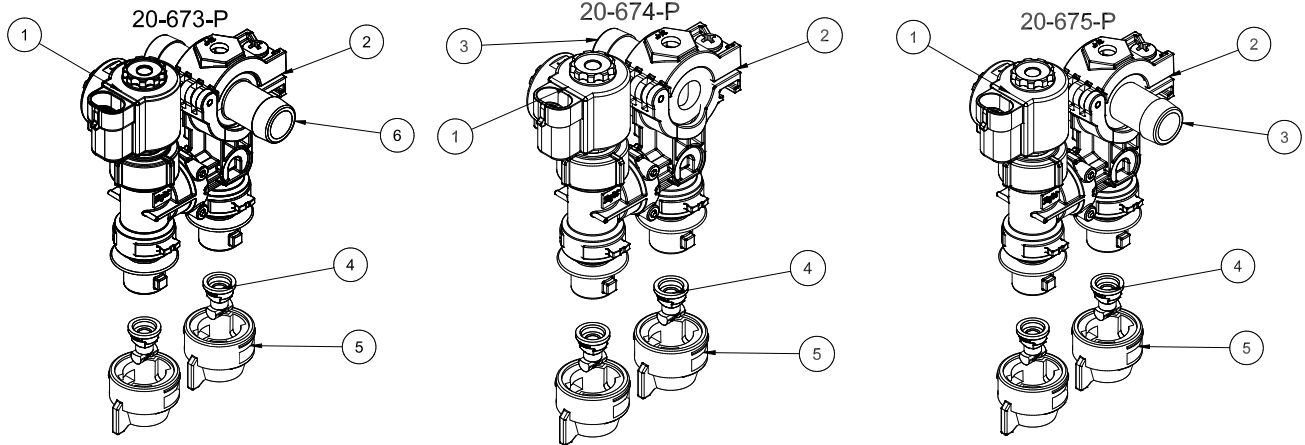

| REF# | PART#     | DESCRIPTION                   | QUANTITY |
|------|-----------|-------------------------------|----------|
| 1*   | 20-673-02 | E-Chemsaver®                  | 1        |
| 2*   | 20-673-04 | 3/4" Bottom Mount Nozzle Body | 1        |
| 3†   | 18-417    | Single Barb                   | 1        |
| 4    | 20-676    | Turbo TeeJet Tip              | 2        |
| 5    | 20-677    | QT White Cap and Washer       | 2        |
| 6‡   | 18-416    | Double Hose Barb              | 1        |

Quantity is per nozzle body. For 18' booms multiply quantity by 11.  
 Quantity is per nozzle body. For 20' booms multiply quantity by 12.

|        |  |        |
|--------|--|--------|
| 20-673 | Double Hose Barb Nozzle (includes * and ‡ item)              | 8 or 9 |
| 20-674 | Single Hose Barb Left Orientation (includes * and † item)    | 2      |
| 20-675 | Single Hose Barb - Right Orientation (includes * and † item) | 2      |

Nozzles are located 20" (51 cm) apart on the right, left, and center tubes. Nozzles are 20" high off ground.

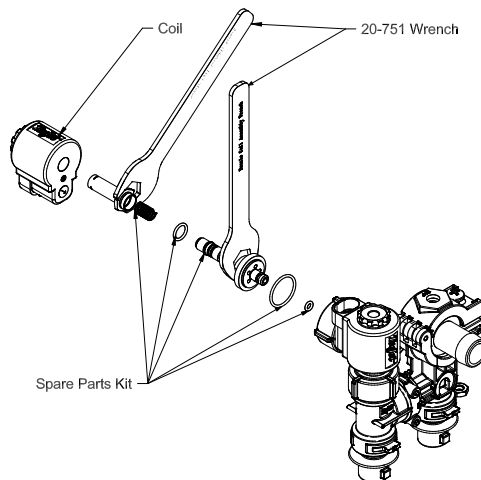

# 20-914 NOZZLE 1215D/1218D/1220D DRAWING

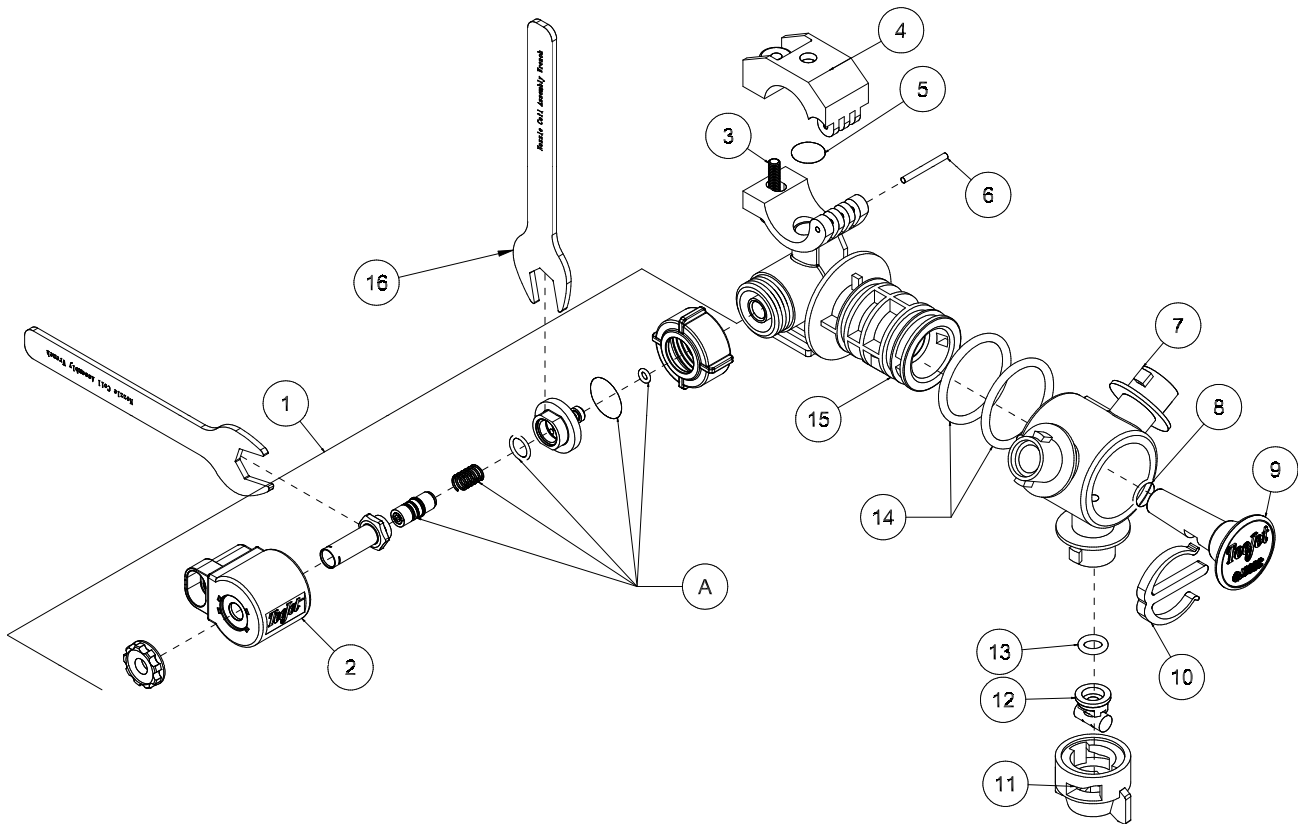

| REF#  | PART#     | DESCRIPTION                                   | QUANTITY |
|-------|-----------|---|----------|
| 1     | 20-807-01 | e-Chemsaver                                   | 1        |
| 2     | 20-751    | Wrench  | 2        |
| 3*    |           | Stainless Steel Screw                         | 1        |
| 4*    |           | Upper Clamp                                   | 1        |
| 5*    | 16-920-03 | O-ring  | 1        |
| 6*    |           | Pivot Pin, Stainless Steel                    | 1        |
| 7*    |           | Turret, 3-Outlet, Nylon                       | 1        |
| 8*    |           | O-ring, EPDM                                  | 1        |
| 9*    |           | Plug  | 1        |
| 10*   |           | E-clip  | 1        |
| 11    | 20-838    | Cap - Gray                                    | 1        |
| 12    | 20-837    | Turbo Twinjet Nozzle Tip, Cap & Gasket - Gray | 1        |
| 13    | 16-800    | Viton Gasket                                  | 1        |
| 14*   |           | O-ring, Teflon                                | 2        |
| 15*   | 33-563    | Body Assembly (includes all * items)          | 1        |
| 16    |           | Locking Ring                                  | 1        |
| 17**† | 20-673-07 | Viton O-ring                                  | 1        |
| 18**† | 20-673-06 | Viton Gasket                                  | 1        |
| 19†   |           | 303 Stainless Steel Cap                       | 1        |
| 20**† |           | Viton O-ring                                  | 1        |
| 21**† |           | 302 Stainless Steel Spring                    | 1        |
| 22**† |           | Plunger                                       | 1        |
| 23†   |           | Tube Sub Assembly                             | 1        |
| 24    | 20-673-09 | 12V Coil                                      | 1        |
| 25†   |           | Nylon Black Nut                               | 1        |
| **    | 20-807-02 | Spare Parts Kit                               |          |
| †     | 20-807-03 | Field Repair Kit                              |          |

Quantity is per nozzle body. For 20' booms multiply quantity by 23. For 18' booms multiply quantity by 21. For 15' booms multiply quantity by 17. Nozzles are located 10" (25 cm) apart on the right, left, and center tubes. Nozzles are 20" high off ground..

# 15-835 TANK RINSING SYSTEM

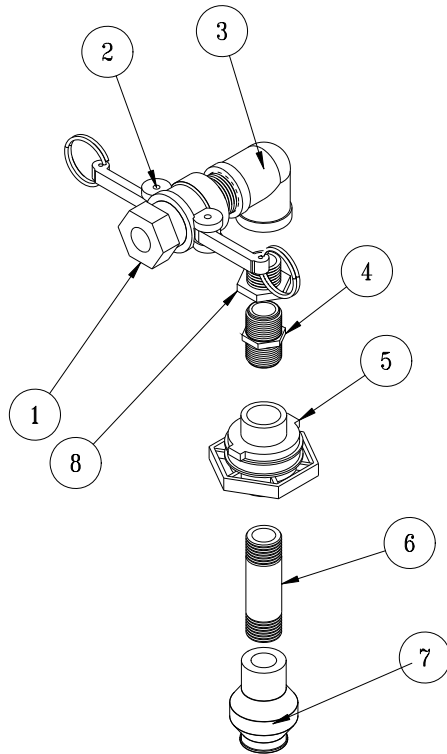

| REF# | PART#  | DESCRIPTION           | QUANTITY |
|------|--------|-----------------------|----------|
| 1    | 16-961 | 1" Adapter            | 1        |
| 2    | 16-962 | 1" Coupler            | 1        |
| 3    | 16-864 | 1" FTP Elbow          | 1        |
| 4    | 16-158 | Close Nipple          | 1        |
| 5    | 16-150 | Double Thread Fitting | 1        |
| 6    | 16-172 | 4" Nipple             | 1        |
| 7    | 15-834 | Tank Rinsing Nozzle   | 1        |
| 8    | 16-163 | Reducer Bushing       | 1        |

Drill 1<sup>3</sup>/<sub>4</sub>" hole 5" from outside edge of cover.  
 Install Tank Rinsing kit as shown, with the Double Thread Fitting (Ref 5) going into the cover.

Basket Must be removed During Use.

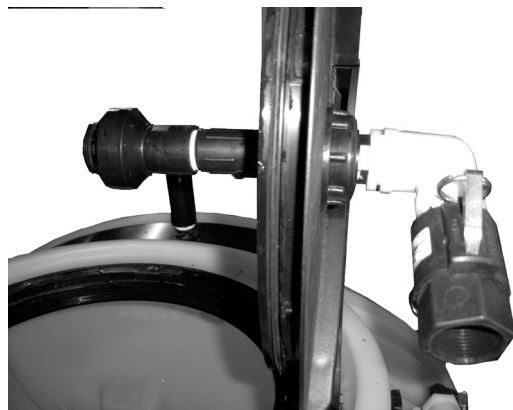

Accessories

# 16-906 ELECTRIC HOSE REEL DRAWING

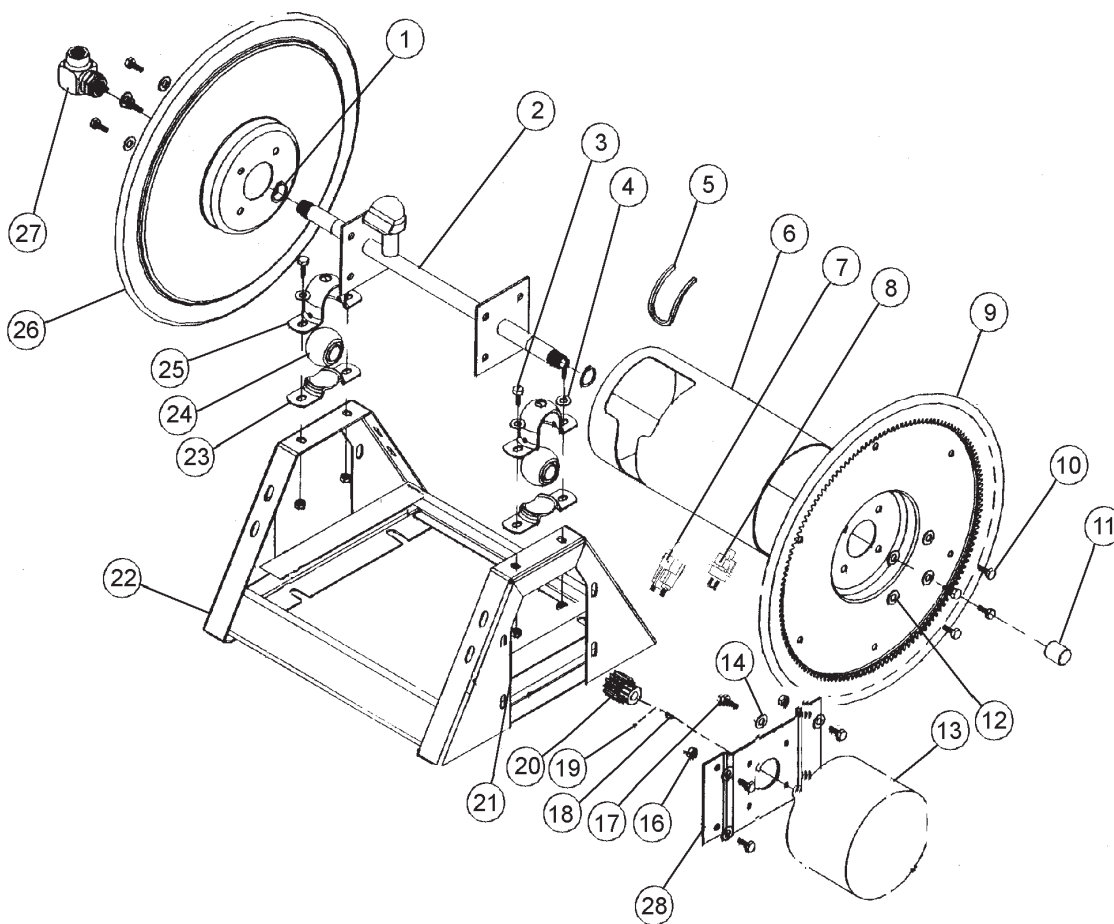

## 16-906 ELECTRIC HOSE REEL PARTS LIST

| REF# | PART#         | DESCRIPTION                                   | QUANTITY |
|------|---------------|---|----------|
| 1    | 16-906-25     | Retaining Ring                                | 2        |
| 2    | 16-906-22     | Axle Assembly                                 | 1        |
| 3    | HB-38-16-100  | Hex Bolt, $\frac{3}{8}$ - 16 x 1              | 4        |
| 4    | HW-38         | Flat Washer, $\frac{3}{8}$                    | 4        |
| 5    | 16-906-27     | Trim, Drum Edge                               | 1        |
| 6    | 16-906-21     | Drum Center                                   | 1        |
| 7    | 13-750        | Solenoid                                      | 1        |
|      | HB-14-20-075  | Hex Bolt, $\frac{1}{4}$ - 20 x $\frac{3}{4}$  | 2        |
|      | HWL-14        | Lock Washer, $\frac{1}{4}$                    | 2        |
|      | HN-14-20      | Hex Nut, $\frac{1}{4}$ - 20                   | 2        |
| 8    | 33-251        | Switch  | 1        |
| 9    | 16-906-19     | Disc and Gear Assembly                        | 1        |
| 10   | HB-516-18-075 | Hex Bolt, $\frac{5}{16}$ - 18 x $\frac{3}{4}$ | 8        |
| 11   | 16-906-26     | Pipe Cap, $\frac{3}{4}$                       | 1        |
| 12   | HWL-516       | Lock Washer, $\frac{5}{16}$                   | 8        |
| 13   | 16-906-15     | $\frac{1}{3}$ HP Motor 12VDC                  | 1        |
| 14   | HW-516        | Flat Washer, $\frac{5}{16}$                   | 4        |
| 16   | HNTL-516-18   | Nylon Lock Nut, $\frac{5}{16}$ - 18           | 4        |
| 17   | HB-516-18-100 | Hex Bolt, $\frac{5}{16}$ -18 x 1              | 4        |
| 18   | 16-906-17     | Key   | 1        |
| 19   |               | Set Screw                                     | 2        |
| 20   | 16-906-29     | Pinion  | 1        |
| 21   | HNTL-38-16    | Nylon Lock Nut, $\frac{3}{8}$ - 16            | 4        |
| 22   | 16-906-18     | Frame Assembly                                | 1        |
| 23   | 16-906-08     | Mounting Pillow Block (Bottom)                | 2        |
| 24   | 16-906-24     | Bearing                                       | 2        |
| 25   | 16-906-07     | Mounting Pillow Block (Top)                   | 2        |
| 26   | 16-906-20     | Disc, 17 $\frac{1}{2}$ "                      | 1        |
| 27   | 16-906-23     | Swivel Assembly, $\frac{3}{4}$                | 1        |
|      | 16-906-30     | Seal Kit (For 16-906-23)                      | 1        |
| 28   | 16-906-28     | Bracket 12VDC                                 | 1        |
|      | 16-982        | Electric Hose Reel (only)                     | 1        |

# ELECTRIC HOSE REEL WIRING DIAGRAM

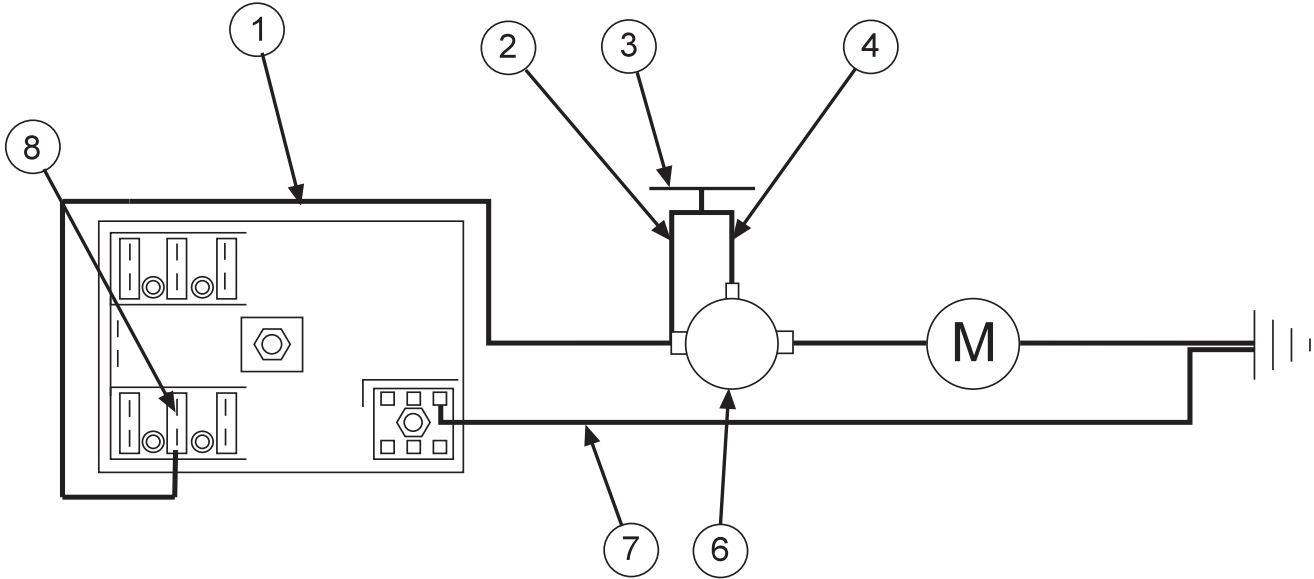

| REF# | PART#    | DESCRIPTION                             | QUANTITY |
|------|----------|---|----------|
| 1    | 8843-132 | Flex-guard $\frac{3}{8}$ ID             | 1        |
|      | 8919-144 | 10GA Red Wire 144"                      | 1        |
|      | 8901     | Slide-On Connector                      | 1        |
| 2    | 16-979   | Wire, Switch to Solenoid Hot Terminal   | 1        |
| 3    | 33-251   | Push Button Switch                      | 1        |
| 4    | 16-978   | Wire, Switch to Solenoid Start Terminal | 1        |
| 6    | 13-750   | Solenoid                                | 1        |

### SOLENOID TERMINALS

|   |            |                             |   |
|---|------------|-----------------------------|---|
|   | HN -516-24 | $\frac{5}{16}$ - 24 Hex Nut | 2 |
|   | HN -10-32  | 10 - 32 Hex Nut             | 1 |
| 7 | 8931-144   | 10GA White Wire 144"        | 1 |
|   | 8901       | Slide-On Connector          | 1 |
| 8 | 33-273     | Auto Blade Type Fuse 30Amp  | 1 |

### CONNECTION INSTRUCTIONS

Route wire harness along side of tank and over to fuse block taking care to stay clear of moving parts or hot engine components. Cut off excess wire and strip back  $\frac{3}{8}$ ". Place one 8963 heat shrink ( $\frac{1}{4} \times 1\frac{1}{4}$ ) on each wire before crimping 8901 slide on connectors to the red and white wires. Connect the two wires to the fuse block first the red to the (+) positive and the white to the (-) negative. Put the 33-273 auto blade type fuse (30 amp) into fuse block.



**WARNING**

Make certain you are connecting positive (+) to positive; negative (-) to negative while attaching power leads. If you do not observe polarity, damage will result to electrical components.

Use Dielectric Grease On All Electrical Connections



## HOSE REEL ADJUSTMENTS

### **OPERATIONAL CHECK:**

1. Pull hose off drum at least one full revolution. A clicking noise should be heard from locking mechanism.
2. Let the hose retract.
3. Pull the hose off until the first click is heard. Drum should lock when the hose tension is removed.
4. Continue pulling the hose, no more than one revolution, until no clicking is heard. Hose should rewind when tension is removed.

### **HOSE REPLACEMENT PROCEDURE:**

1. Facing swivel, turn the hose drum clockwise until all of the hose is removed from the drum and the drum is held by locking mechanism. Make sure spring is locked.
2. Remove hose clamps and disconnect hose from swivel. Remove old hose.
3. Insert new hose through roller guide, connect to swivel and reinstall hose clamps. Use spring guard over hose to protect the hose from being cut by the drum.
4. Remove check ball from old hose and install on replacement hose.
5. Carefully, keeping the tension on the hose, pull the hose to release the locking mechanism. Let the hose wind on the drum.

# 16-129 MANUAL HOSE REEL DRAWING

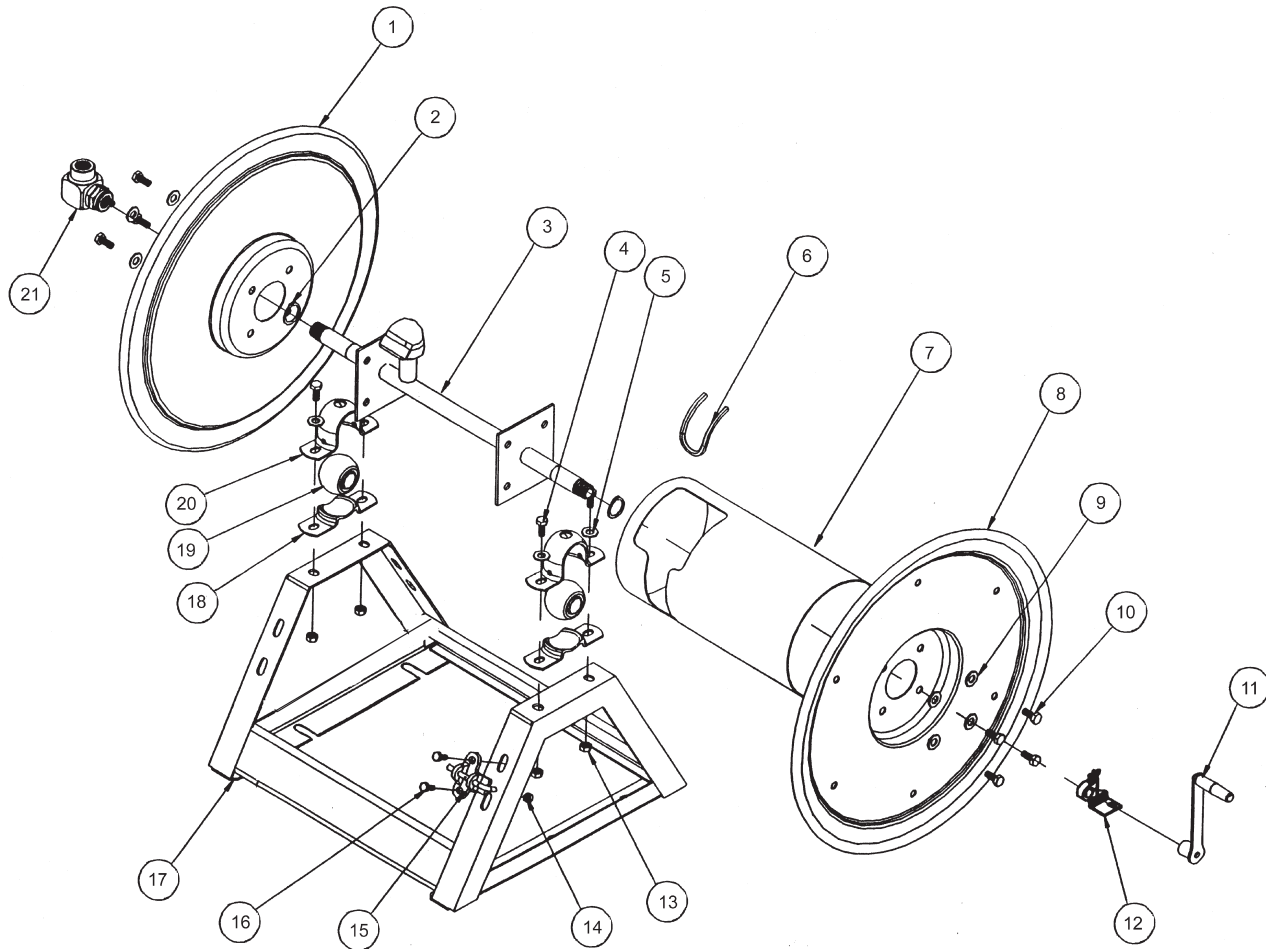

| REF# | PART#         | DESCRIPTION                                  | QUANTITY |
|------|---------------|--|----------|
| 1    | 16-129-11     | Disc 17 $\frac{1}{2}$                        | 1        |
| 2    | 16-906-25     | Retaining Ring                               | 2        |
| 3    | 16-906-22     | Axle Assembly $\frac{3}{4}$                  | 1        |
| 4    | HB-38-16-100  | Hex Bolt $\frac{3}{8}$ - 16 x 1              | 4        |
| 5    | HW-38         | Washer $\frac{3}{8}$                         | 4        |
| 6    | 16-906-27     | Trim, Drum Edge                              | 1        |
| 7    | 16-906-21     | Drum Center                                  | 1        |
| 8    | 16-906-20     | Disc 17 $\frac{1}{2}$ , Crank Side           | 1        |
| 9    | HWL-516       | Lockwasher $\frac{5}{16}$                    | 8        |
| 10   | HB-516-18-075 | Hex Bolt $\frac{5}{16}$ - 18 x $\frac{3}{4}$ | 8        |
| 11   | 16-129-09     | Crank Assembly $\frac{3}{4}$                 | 1        |
| 12   | 16-129-10     | Brake Assembly $\frac{3}{4}$                 | 1        |
| 13   | HNTL-38-16    | Nylon Lock Nut $\frac{3}{8}$ - 16            | 4        |
| 14   | HNTL-516-18   | Nylon Lock Nut $\frac{5}{16}$ - 18           | 2        |
| 15   | 16-129-03     | Lock Pin Assembly                            | 1        |
| 16   | HB-516-18-075 | Hex Bolt $\frac{5}{16}$ - 18 x $\frac{3}{4}$ | 2        |
|      | HW-516        | Washer $\frac{5}{16}$                        | 2        |
| 17   | 16-129-07     | Frame Assembly                               | 1        |
| 18   | 16-906-08     | Mounting Pillow Block (Bottom)               | 2        |
| 19   | 16-906-24     | Bearing                                      | 2        |
| 20   | 16-906-07     | Mounting Pillow Block (Top)                  | 2        |
| 21   | 16-906-23     | Swivel Assembly $\frac{3}{4}$                | 1        |
|      | 16-906-30     | Seal Kit ( For 16-906-23 )                   | 1        |

Accessories

# 15-967 HOSE REEL MOUNT

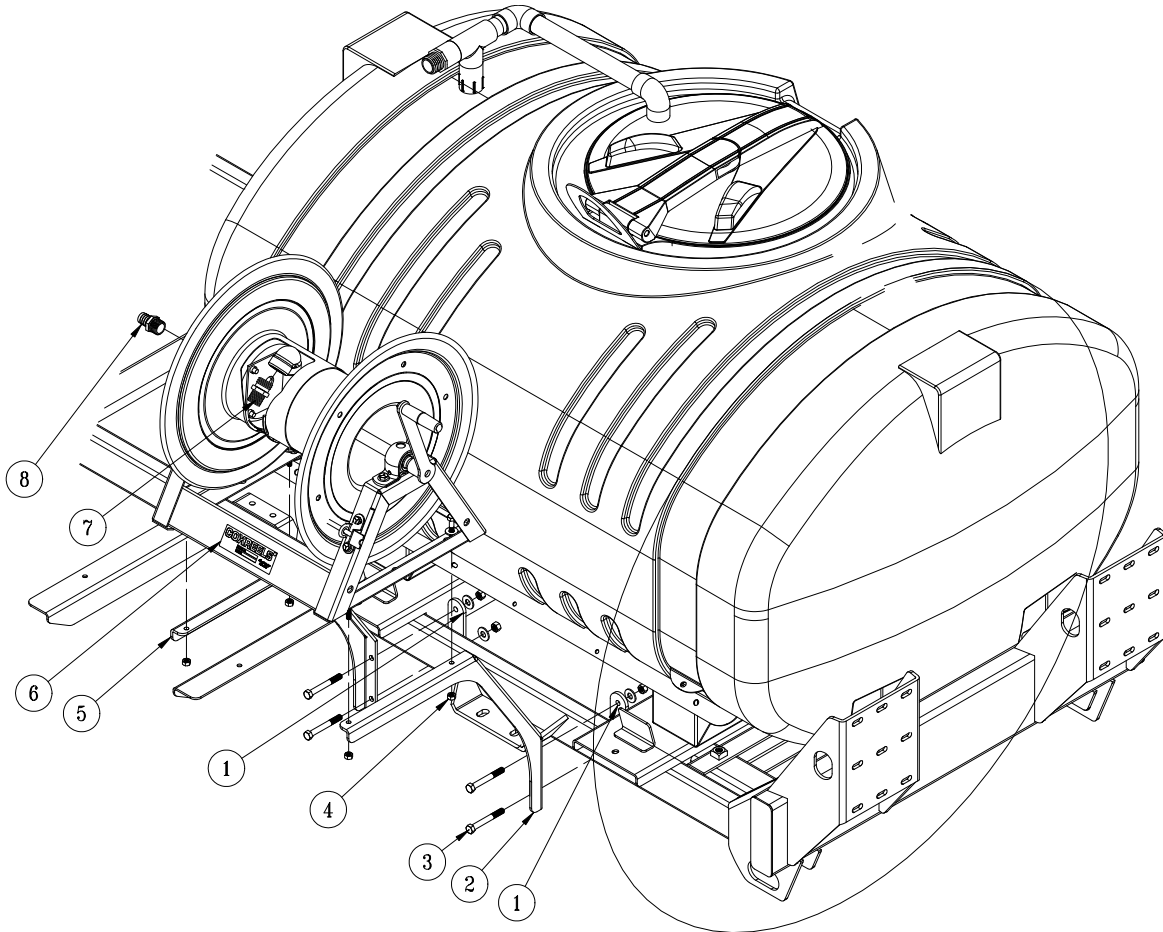

| REF# | PART#         | DESCRIPTION   | QUANTITY |
|------|---------------|---|----------|
| 1    | 20-799        | Backing Plate                                       | 2        |
| 2    | 20-788        | Rear Hose Reel Mount                                | 1        |
| 3    | HB-38-16-300  | Hex Bolt, $\frac{3}{8}$ - 16 x 3                    | 4        |
|      | HNTL-38-16    | Nylon Lock Nut, $\frac{3}{8}$ - 16                  | 4        |
|      | HW-38         | Flat Washer, $\frac{3}{8}$                          | 4        |
| 4    | HB-516-18-150 | Hex Bolt, $\frac{5}{16}$ - 18 x $1\frac{1}{2}$      | 4        |
|      | HNTL-516-18   | Nylon Lock Nut, $\frac{5}{16}$ - 18                 | 4        |
|      | HW-516        | Flat Washer, $\frac{5}{16}$                         | 4        |
| 5    | 20-789        | Front Hose Reel Mount                               | 1        |
| 6    | 16-906        | Electric Hose Reel                                  | 1        |
|      | 16-129        | Manual Hose Reel                                    | 1        |
| 7    | 16-295        | Hose Fitting  | 1        |
| 8    | 18-249        | Brass Fitting, $\frac{3}{4}$ MPT x $\frac{3}{4}$ HB | 1        |

1. Wear protective clothing when draining the tank and taking apart the lines.
2. Drain tank and spray system in a safe and approved method ensuring that no chemical or water remain in tank as you will be taking apart lines.
3. Remove key from ignition, set park brake and block wheels.
4. Install Front Mount(Ref. 2) using Backing Plate(Ref. 1) and two  $\frac{3}{8}$  x 3 Hex Bolts, Nuts and Washers. Repeat with Rear Mount(Ref. 5). Leave loose to reposition.
5. Position Hose Reel on Mounts. Use four Hex Bolts  $\frac{5}{16}$  - 18 x  $1\frac{1}{2}$  and four  $\frac{5}{16}$  - 18 Nylon Lock Nuts to hold in place. Tighten Hex Bolts.
6. Tighten Mount Bolts(Ref 3).
7. Put 18-249 barb fitting(Ref. 8) into hose reel end and 16-295 hose fitting(Ref 7) into center of hose reel.

# RADION HOSE REEL PLUMBING

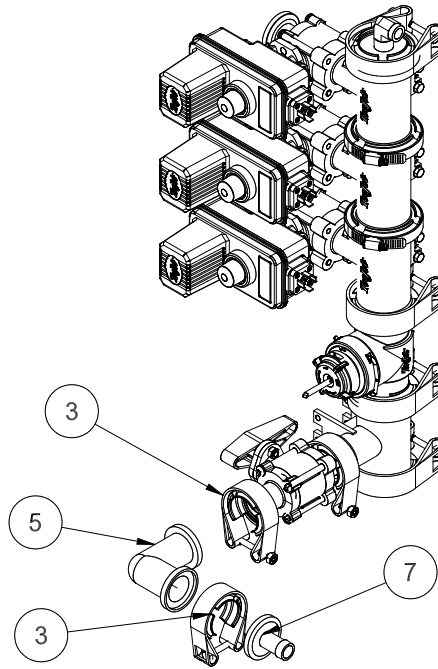

## TEEJET RADION 8140

| REF# | PART#  | DESCRIPTION        | QUANTITY |
|------|--------|--------------------|----------|
| 3    | 15-740 | 50 Series Clamp    | 3        |
| 5    | 15-736 | #50 Elbow Coupling | 1        |
| 7    | 15-749 | Hose Barb          | 1        |

### INSTALLATION INSTRUCTIONS

1. TeeJet 8140: Some machines have the ball valve already installed. Remove cover from the tee or the ball valve. Install the rest of the fittings as shown.
2. Route the  $\frac{3}{4}$ " hose from the hose barb to the hose barb on the hose reel and secure with a 18-040 Hose clamp.
3. Secure the hose to the machine with a nylon tie strap.
4. There may be parts left over that you will not need.

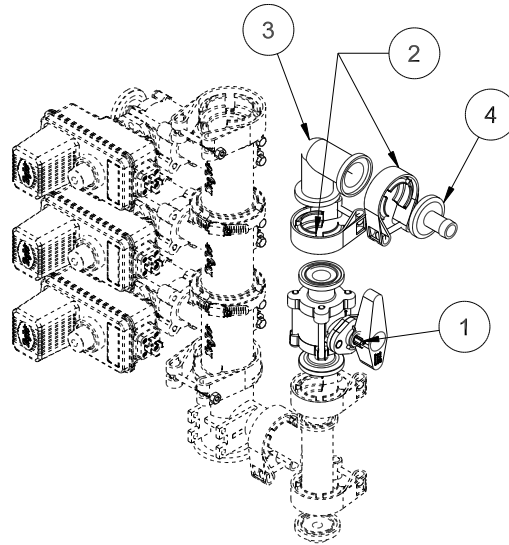

| REF# | PART#  | DESCRIPTION        | QUANTITY |
|------|--------|--------------------|----------|
| 1    | 15-738 | Flanged Ball Valve | 1        |
| 2    | 15-740 | 50 Series Clamp    | 2        |
| 3    | 15-736 | #50 Elbow Coupling | 1        |
| 4    | 15-749 | Hose Barb          | 1        |

## INSTALLATION INSTRUCTIONS

**Some machines are shipped with the flanged ball valve already installed. If your machine has the ball valve on the tee, remove cap from ball valve and skip to step 3.**

1. Between the boom control valves and the fuel tank you will find a tee fitting with a black cap on top of it. Remove the clamp and the cap.
2. Install the 15-738 ball valve (Ref 1) onto the top of the tee using the clamp and o-ring you removed in step 1. The Handle can be positioned so it clears the other hoses by rotating it before the clamp is tightened. Tighten clamp when ball valve is in the position you wanted.
3. Install the 15-736 Elbow (Ref 3) on top of the ball valve pointing to the back of the machine and secure with 15-740 clamp (Ref 2). Tighten.
4. Install the 15-749 flanged hose barb (Ref 4) on to the open end of the elbow with a 15-740 clamp (Ref 2). Tighten.
5. Route the  $\frac{3}{4}$ " hose from the hose barb you just installed to the hose barb on the hose reel. Secure with an 18-40 hose clamp. Secure hose to machine with 22-075 nylon ties.
6. There will be parts left over that you will not need.

# 15-965 FOAM MARKER DRAWING

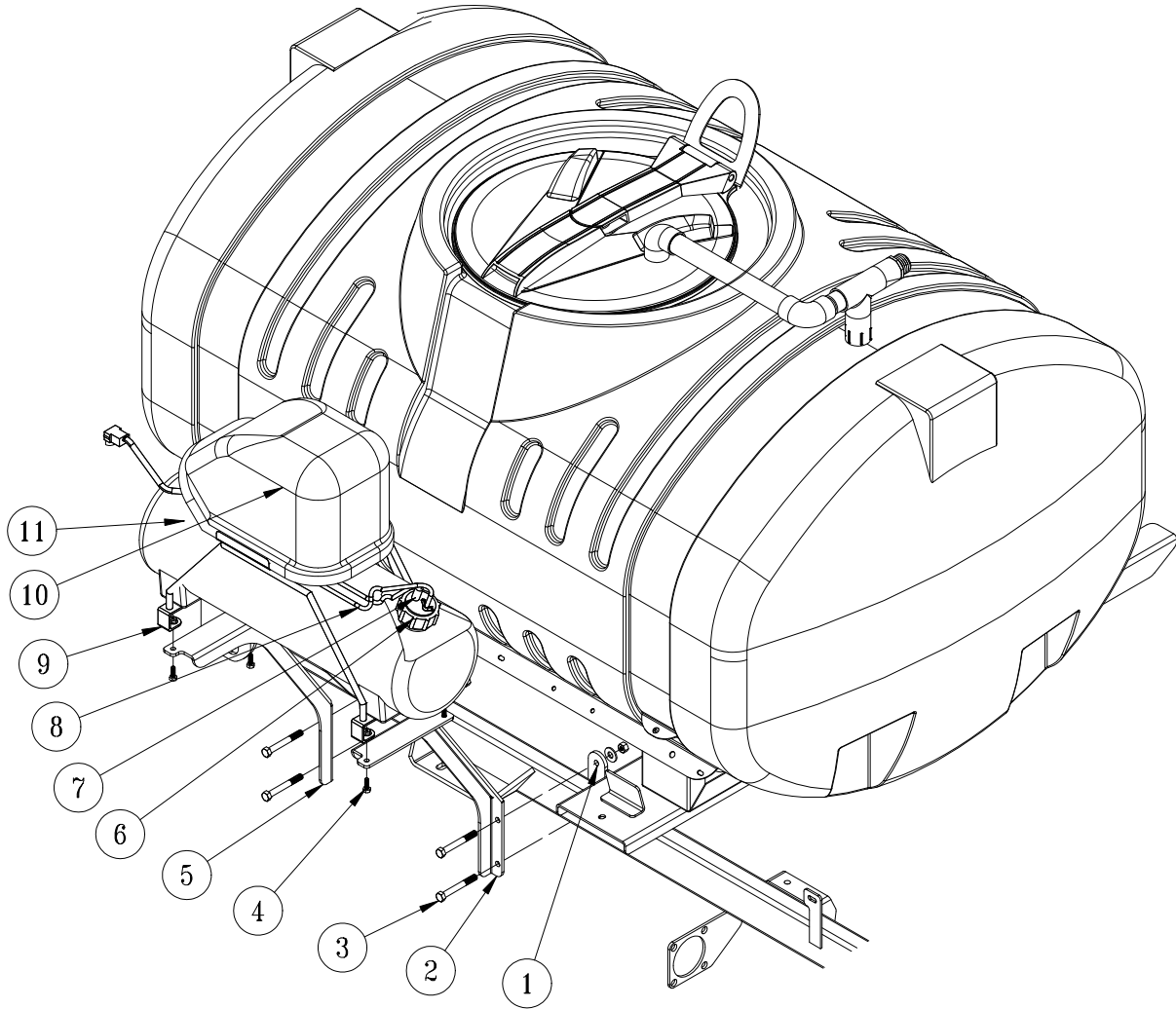

| REF# | PART#        | DESCRIPTION                                  | QUANTITY |
|------|--------------|--|----------|
| 1    | 20-799       | Backing Plate                                | 2        |
| 2    | 20-791       | Front Foamer Mount                           | 1        |
| 3    | HB-38-16-300 | Hex Bolt, $\frac{3}{8}$ - 16 x 3             | 4        |
|      | HNTL-38-16   | Nylon Lock Nut, $\frac{3}{8}$ - 16           | 4        |
|      | HW-38        | Flat Washer, $\frac{3}{8}$                   | 4        |
| 4    | HB-14-20-075 | Hex Bolt, $\frac{1}{4}$ - 20 x $\frac{3}{4}$ | 4        |
|      | HNFL-14-20   | Flange Whiz-loc Nut, $\frac{1}{4}$ - 20      | 4        |
| 5    | 20-790       | Rear Foamer Mount                            | 1        |
| 6    | 14-284-02    | Cap Assembly                                 | 1        |
| 7    |              | Clear Tube                                   | 1        |
| 8    |              | Blue Tube                                    | 1        |
| 9    | 14-291-04    | Tank Bracket                                 | 2        |
| 10   | 14-291-03    | Compressor Only                              | 1        |
|      | 14-291-01    | Black Cover                                  | 1        |
| 11   | 14-291-02    | Foamer Tank                                  | 1        |
| 6-11 | 14-291       | Foamer (includes parts 6-11)                 | 1        |

# 15-965 FOAM MARKER CONTROL PANEL

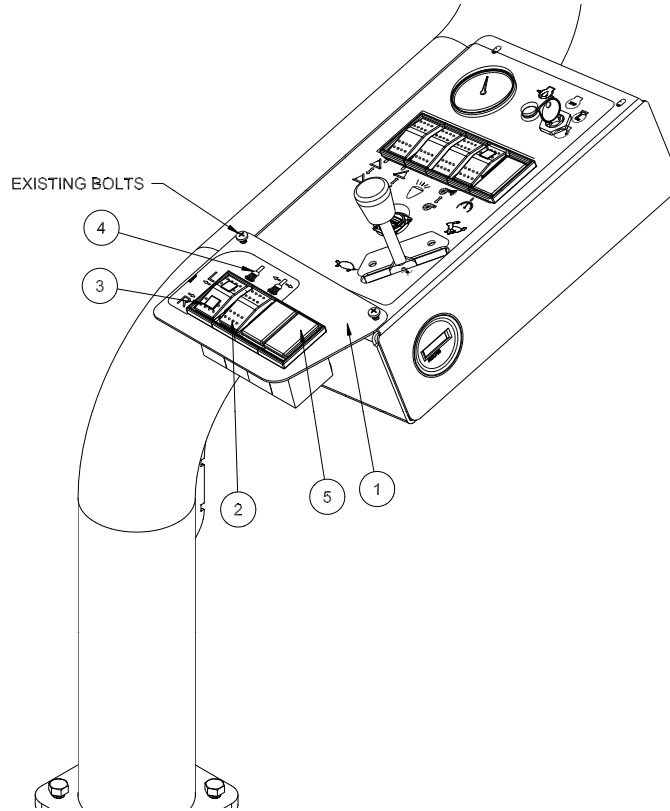

| REF# | PART#  | DESCRIPTION          | QUANTITY |
|------|--------|----------------------|----------|
| 1    | 10-739 | Switch Mount Plate   | 1        |
|      | 15-725 | Panel Mount End      | 2        |
| 2    | 15-782 | Switch, Unlit        | 1        |
|      | 15-727 | Rocker, No Light     | 1        |
| 3    | 15-918 | Switch, 2 Red LED    | 1        |
|      | 15-917 | Rocker, 2 Red Lenses | 1        |
| 4    | 30-374 | Decal, Foamer        | 1        |

**Safety: Before working on machine: stop engine, set park brake, remove key from ignition and block wheels. Disconnect negative (-) battery terminal.**

1. Place decal(Ref 4) on Switch mount plate. Place panel mount ends in mount plate.
2. Mount switches(Ref 2 & 3) to switch mount plate(Ref 1) as shown above. Mount the switch mount plate(Ref 1) on the side control panel using existing bolts.

### Tank Mount Drawing

3. Position the Front Foamer Mount(Ref 2) and one Backing Plate on the right hand side of the mainframe ahead of the rear axle, secure using two  $\frac{3}{8}$  x 3 bolts, flat washers and lock nuts. Repeat with the Rear Foamer Mount(Ref 5). *Leave loose enough to reposition when mounting the Foamer(Refs 6-11).*
4. Place Foamer unit(Refs 6-11) onto the Mounts. Using the  $\frac{1}{4}$  x  $\frac{3}{4}$  Bolts and  $\frac{1}{4}$  Flange Lock Nuts fasten Foamer to Mounts. Tighten hardware.
5. Tighten hardware securing Foamer Mounts to the mainframe.

# FOAMER NOZZLE MOUNT

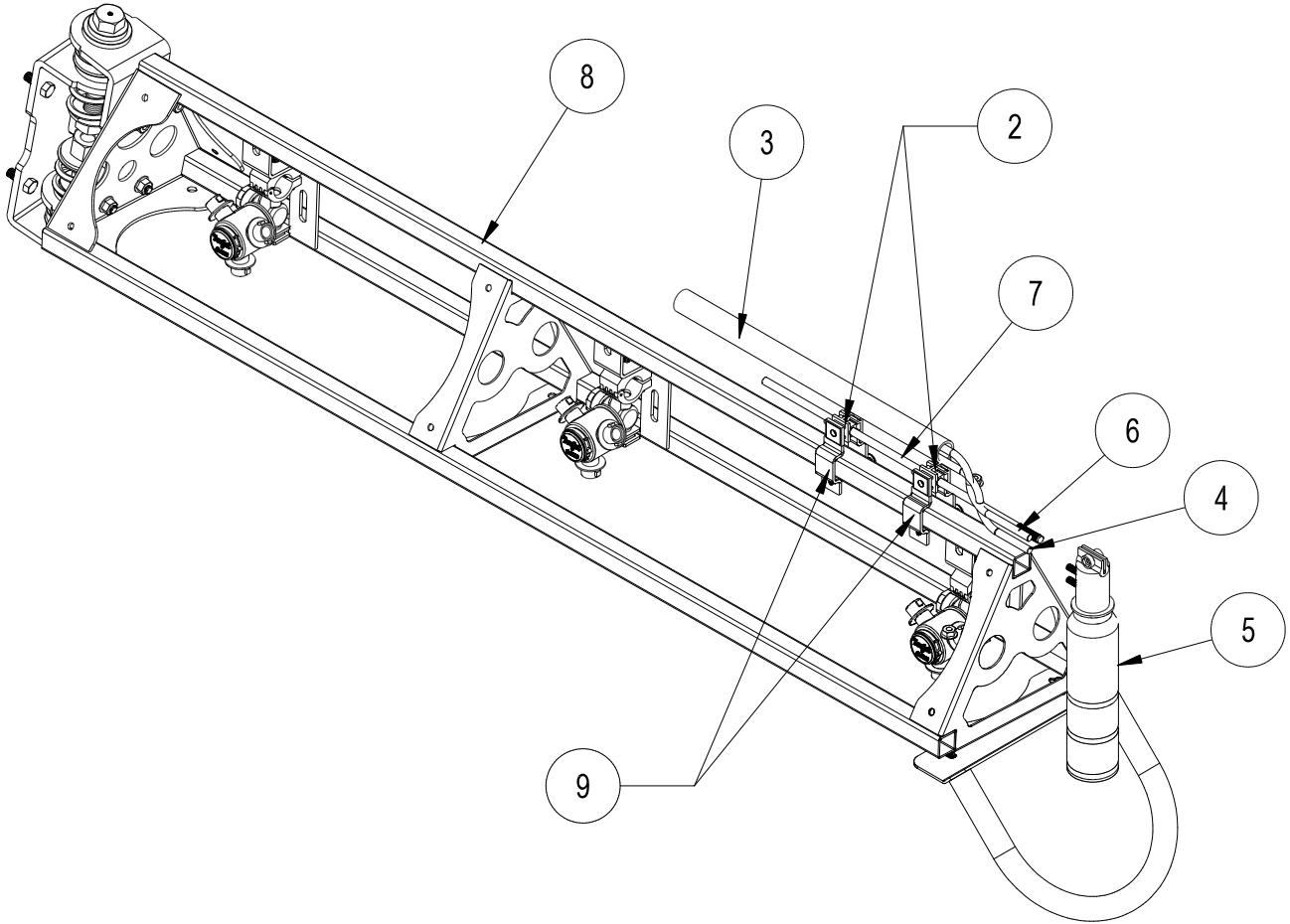

Accessories

| REF# | PART#     | DESCRIPTION              | QUANTITY   |
|------|-----------|--------------------------|------------|
| 2    | 16-987    | Foam Nozzle Mounting Kit | 1 per boom |
| 3    | 15-507    | Foamer Tubing            | 1          |
| 4    |           | Clear Tubing             |            |
| 5    | 15-511    | Foam Nozzle              | 2          |
| 6    |           | Blue Tubing              |            |
| 7    | 15-510-01 | Nozzle Mounting Rod      | 2          |
| 8    |           | Boom                     |            |
| 9    | 16-795    | Square Clamp             | 4          |



## INSTRUCTIONS

1. Slide hose clamp onto drop tube of foam nozzle and attach restricter bell.
2. Place splined end of Nozzle mounting rod (Ref 7) into top of foam nozzle (Ref 5). Tighten screw.
3. Slide two foam nozzle mounts (Ref 2) onto the rod. Place square clamps (Ref 9) on foam nozzle mounts and mount the square clamps to the boom (Ref 8). Adjust foam nozzle mounts and clamps so nozzle assembly will clear end of boom. Tighten foam nozzle mounts and square clamps to prevent side to side movement. Do the same to the other side.
4. Being careful not to cut the tubing (Ref 3), cut the oversleeve back approximately 2" (5 cm) to expose blue (Ref 6) and clear tubing (Ref 4).
5. Remove blue wing nut from top connector of foam nozzle and slide it on the blue tube with the threads facing toward end of tube. Slide blue tube all the way over the top of the small tube on foam nozzle. Slide wing nut back to the threads and hand tighten. Follow the same steps for the clear tube and tube nut.
6. Route the tubing along underside of main frame using tie downs as necessary.
7. Install opposite ends of air-liquid tubes to compressor, again cutting back the oversleeve approximately 2" (5 cm) and inserting blue and clear tubes for the left boom section into the tubing connectors (Ref A) on the right side of compressor as far as possible.
8. Follow the same steps for the right boom tubing. Notice the right boom is inserted into left side of compressor. To release tubing from compressor, hold black ring around tubing, and pull tube out.
9. Hose's must be routed on bottom of the boom square tubing.
10. Install hose guard using 2 drill screws (you may want to drill a  $\frac{3}{16}$  pilot hole first).
11. Place another hose guard against first and install in same manner.
12. Repeat process for other boom side.
13. Connect small plastic electrical plug under compressor to electrical extension cable.
14. Cut cable and strip casing, allowing enough length to connect to fuse block.
15. Strip and connect slide on connectors to each wire and use the heat shrink.
16. Connect black negative (-) wire to the ground and connect red wire to the positive (+).
17. Insert 10 amp fuse into slot which red wire was attached to.

# 14-291 FOAMER REPLACEMENT PARTS

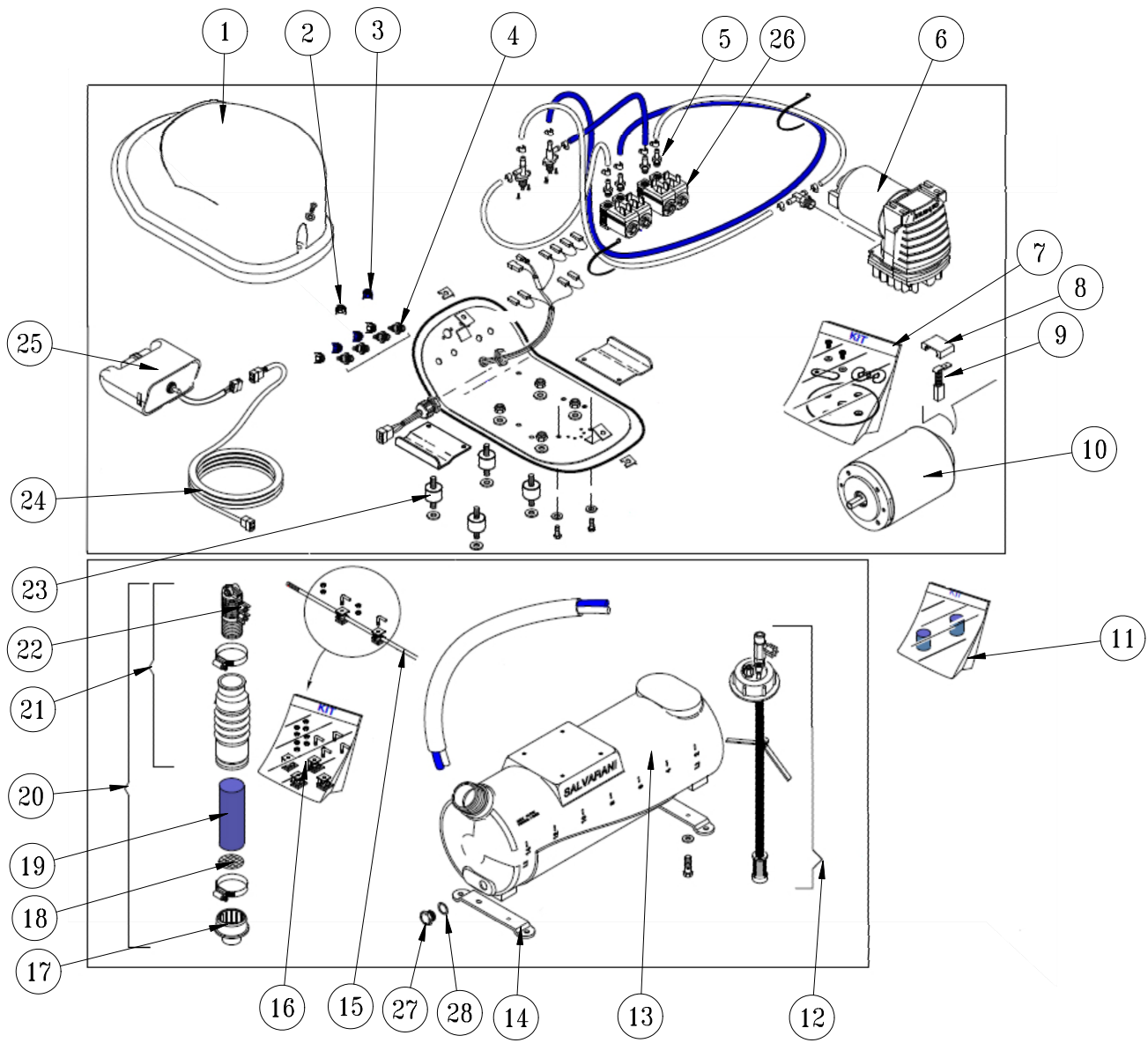

Accessories

## 14-291 FOAMER REPLACEMENT PARTS

| REF# | PART#     | DESCRIPTION               | QUANTITY |
|------|-----------|---------------------------|----------|
| 1    | 14-291-01 | Black Cover               | 1        |
| 2    | 14-291-08 | White Fly Nut             | 1        |
| 3    | 14-291-09 | Blue Fly Nut              | 1        |
| 4    | 14-284-10 | Tubing Connector          | 1        |
| 5    | 14-291-17 | M6 Tubing Connector       | 1        |
| 6    | 14-536    | Compressor Complete       | 1        |
| 7    | 14-291-11 | Diaphragm Replacement Kit | 1        |
| 8    | 15-505-08 | Brush Retainer            | 1        |
| 9    | 15-505-06 | Brush                     | 1        |
| 10   | 15-505-07 | 12V Electric Motor        | 1        |
| 11   | 15-511-02 | Foam Sponge               | 1        |
| 12   | 14-284-02 | Cap Assembly              | 1        |
| 13   | 14-291-02 | Foamer Tank               | 1        |
| 14   | 14-291-04 | Tank Brackets             | 2        |
| 15   | 15-510-01 | Nozzle Mounting Rod       | 2        |
| 16   | 16-987    | Foam Nozzle Mounting Kit  | 1        |
| 17   | 14-284-09 | Foam Nozzle Reducer       | 2        |
| 18   | 15-511-09 | Stainless Steel Screen    | 2        |
| 19   | 15-511-08 | Long Foam Sponge          | 2        |
| 20   | 15-511    | Foam Nozzle               | 2        |
| 21   | 15-511-07 | Foam Nozzle Assembly      | 1        |
| 22   | 15-511-01 | Foam Nozzle Sub Assembly  | 1        |
| 23   | 14-291-15 | Shock Absorber            | 4        |
| 24   | 14-284-05 | Extension Wire            | 1        |
| 25   | 14-291-05 | Switch Box                | 1        |
|      | 15-506-02 | Switch                    | 1        |
| 26   | 14-284-11 | Solenoid Valve            | 4        |
| 27   | 14-291-19 | Drain Plug                | 1        |
| 28   | 14-291-18 | Drain Plug Seal           | 1        |

# FOAM MARKER WIRING

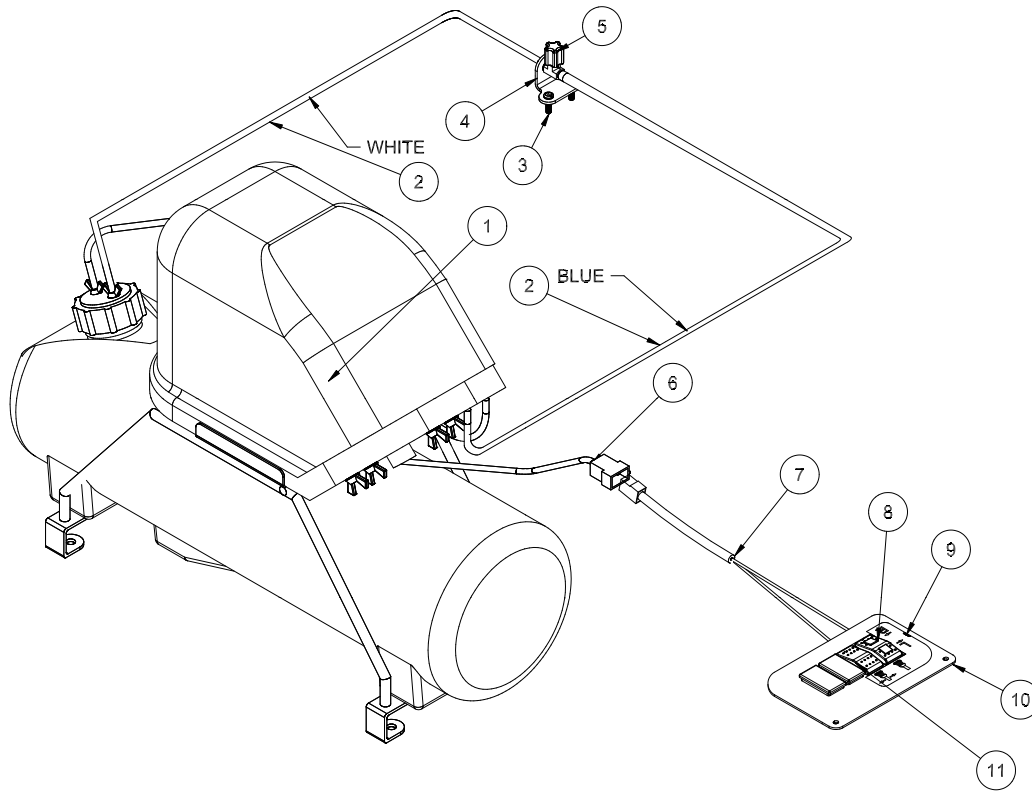

| REF# | PART#         | DESCRIPTION                 | QUANTITY |
|------|---------------|-----------------------------|----------|
| 1    | 14-291-03     | Compressor                  | 1        |
| 2    | 15-507        | Tubing -Blue and white      | 1        |
| 3    | HSM-10-32-075 | Machine Screw, #10-32 x 3/4 | 2        |
|      | HNFL-10-32    | Flange Whiz-loc Nut, #10-32 | 2        |
| 4    | 20-769        | Mount Bracket               | 1        |
| 5    | 14-699        | Male Coupler                | 1        |
|      | 14-291-09     | Blue Fly Nut                | 1        |
|      | 14-702        | Red Washer                  | 1        |
| 6    | 15-504-04     | Foam Marker Wiring Harness  | 1        |
| 7    | 32-574        | Foamer Wire Harness         | 1        |
| 8    | 15-918        | Switch, 2 Red LED           | 1        |
|      | 15-917        | Rocker, 2 Red Lenses        | 1        |
| 9    | 30-374        | Decal, Foamer               | 1        |
| 10   | 10-739        | Switch Mount Plate          | 1        |
| 11   | 15-782        | Switch, Unlit               | 1        |
|      | 15-727        | Rocker, No Light            | 1        |

## INSTALLATION

1. Connect the compressor wire harness (Ref 6) to the switches using the wire harness (Ref 7).
2. Use dielectric grease on all electrical connections. Route the wire harness to the battery and out of the way of any heat or moving parts. Use nylon ties as needed. Connect the wire harness to the battery. Red to positive(+), black to negative(-).

## 20-815 WATER METER KIT (GALLONS)

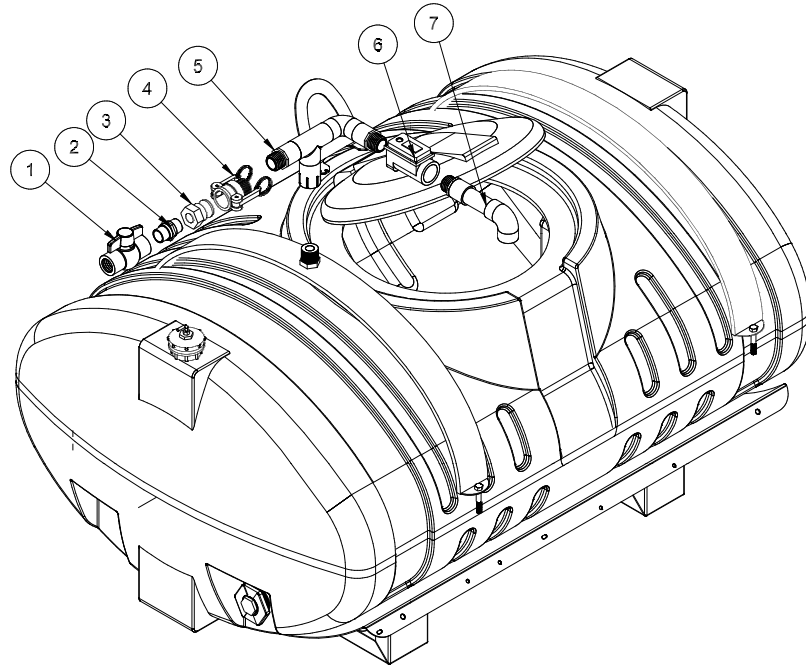

| REF # | PART # | DESCRIPTION                                   | QUANTITY |
|-------|--------|---|----------|
| 1     | 18-448 | 1" Ball Valve (already on machine)            | 1        |
| 2     | 16-851 | 1" Nipple (already on machine)                | 1        |
| 3     | 16-961 | 1" Adapter Quick Coupler (already on machine) | 1        |
| 4     | 16-962 | 1" Quick Coupler (already on machine)         | 1        |
| 5     | 20-813 | Filler Inlet                                  | 1        |
| 6     | 14-804 | Water Meter                                   | 1        |
| 7     | 20-814 | Filler Outlet                                 | 1        |

1. Thoroughly flush the service line upstream of the meter to remove dirt and debris.
2. The DLJ Meter is for use **only** with **COLD WATER** up to 122°F (50°C)
3. Slowly open any upstream valves to prevent damage to the meter.

### Gallons to Cubic feet Conversion :

Multiply gallons reading by 0.1337 to get cubic feet.

There are 7.48052 gallon per cubic foot.

# 15-968 20 GALLON RINSE TANK PARTS LIST

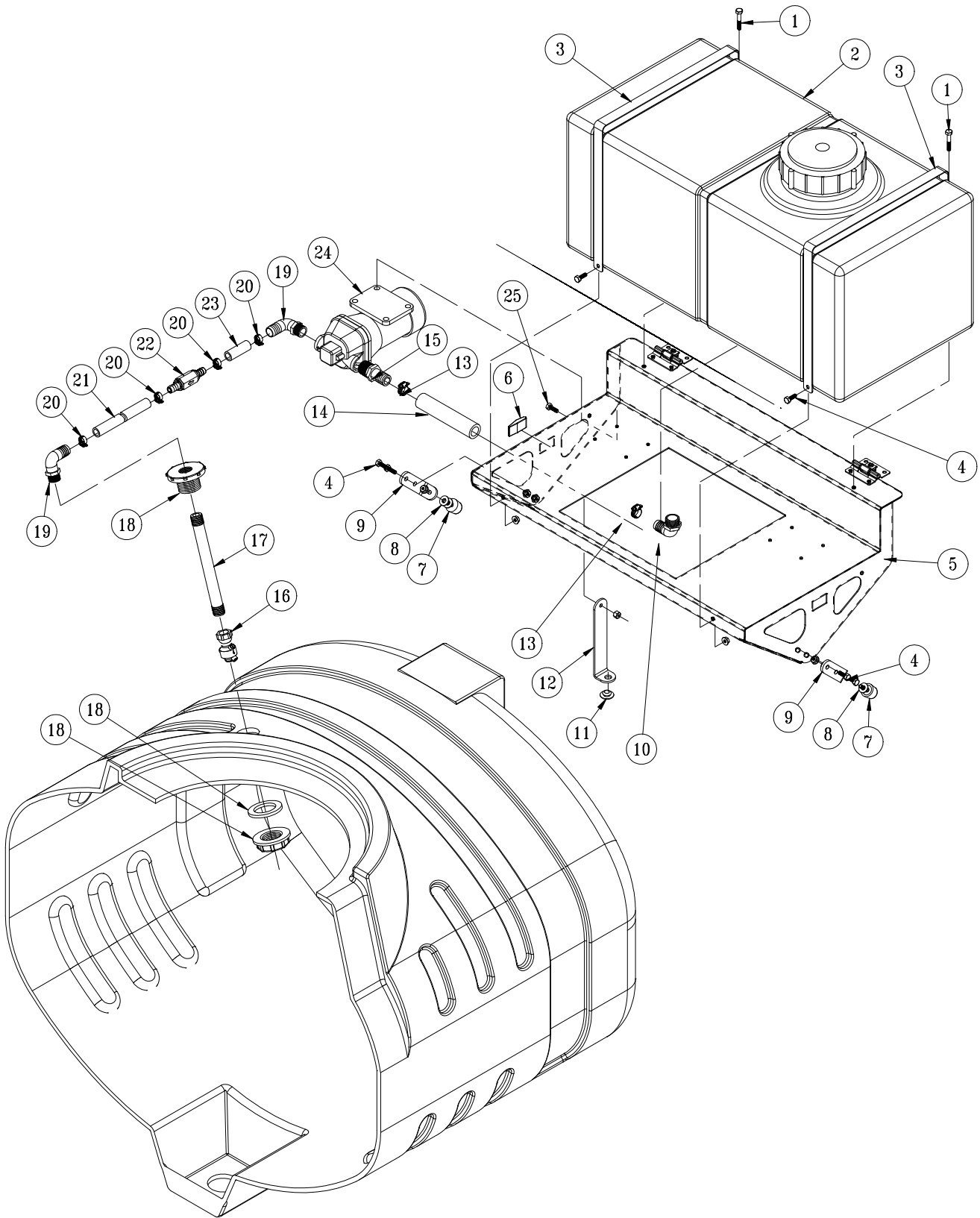

Accessories

## 15-968 20 GALLON RINSE TANK PARTS LIST

| REF# | PART#        | DESCRIPTION                                       | QUANTITY |
|------|--------------|---|----------|
| 1    | HB-14-20-150 | Hex Bolt, $\frac{1}{4}$ - 20 x $1\frac{1}{2}$     | 2        |
|      | HNFL-14-20   | Flange Lock Nut, $\frac{1}{4}$ - 20               | 2        |
| 2    | 20-797       | 20 Gallon Tank                                    | 1        |
| 3    | 20-800       | Tank Strap  | 2        |
| 4    | HB-14-20-075 | Hex Bolt, $\frac{1}{4}$ - 20 x $\frac{3}{4}$      | 6        |
|      | HNFL-14-20   | Flange Lock Nut, $\frac{1}{4}$ - 20               | 6        |
| 5    | 20-792       | Rinse Tank Mount                                  | 1        |
| 6    | 15-726       | Lighted Rocker Switch                             | 1        |
|      | 15-917       | Red Rocker  | 1        |
| 7    | 15-013       | Rubber Bumper                                     | 2        |
|      | HNFL-14-20   | Flange Lock Nut, $\frac{1}{4}$ - 20               | 2        |
| 8    | HW-14        | Flat Washer, $\frac{1}{4}$                        | 4        |
| 9    | 20-801       | Bumper Mount                                      | 2        |
| 10   | 16-153       | Elbow   | 1        |
| 11   | 42-116       | Rubber Pad  | 1        |
| 12   | 15-933       | Prop Strap  | 1        |
| 13   | 18-040       | Hose Clamp, HS12                                  | 2        |
| 14   | 9032         | Black Hose, $\frac{3}{4}$                         | 5.5"     |
| 15   | 18-489       | Connector, $\frac{1}{2}$ NPT x $\frac{3}{4}$ Barb | 1        |
| 16   | 30-246       | Rinse Nozzle                                      | 1        |
| 17   | 30-247       | PVC Nipple  | 1        |
| 18   | 33-495       | Bulkhead Fitting                                  | 1        |
| 19   | 16-186       | Elbow, $\frac{1}{2}$ NPT x $\frac{3}{4}$ Barb     | 2        |
| 20   | 18-077       | Hose Clamp, HS10                                  | 3        |
| 21   | 9050         | Nylon Clear Tubing, $\frac{1}{2}$                 | 60"      |
| 22   | 18-497       | Check Valve                                       | 1        |
| 23   | 9050         | Nylon Clear Tubing, $\frac{1}{2}$                 | 2"       |
| 24   | 20-798       | Pump, 4 GPM                                       | 1        |
| 25   | HB-14-20-075 | Hex Bolt, $\frac{1}{4}$ - 20 x $\frac{3}{4}$      | 1        |
|      | HNTL-14-20   | Nylon Lock Nut, $\frac{1}{4}$ - 20                | 1        |



**WARNING**

This tank is for fresh clear water ONLY. Do not put chemicals in this tank.

# 30-006 FRESH WATER WASH TANK -REAR MOUNT

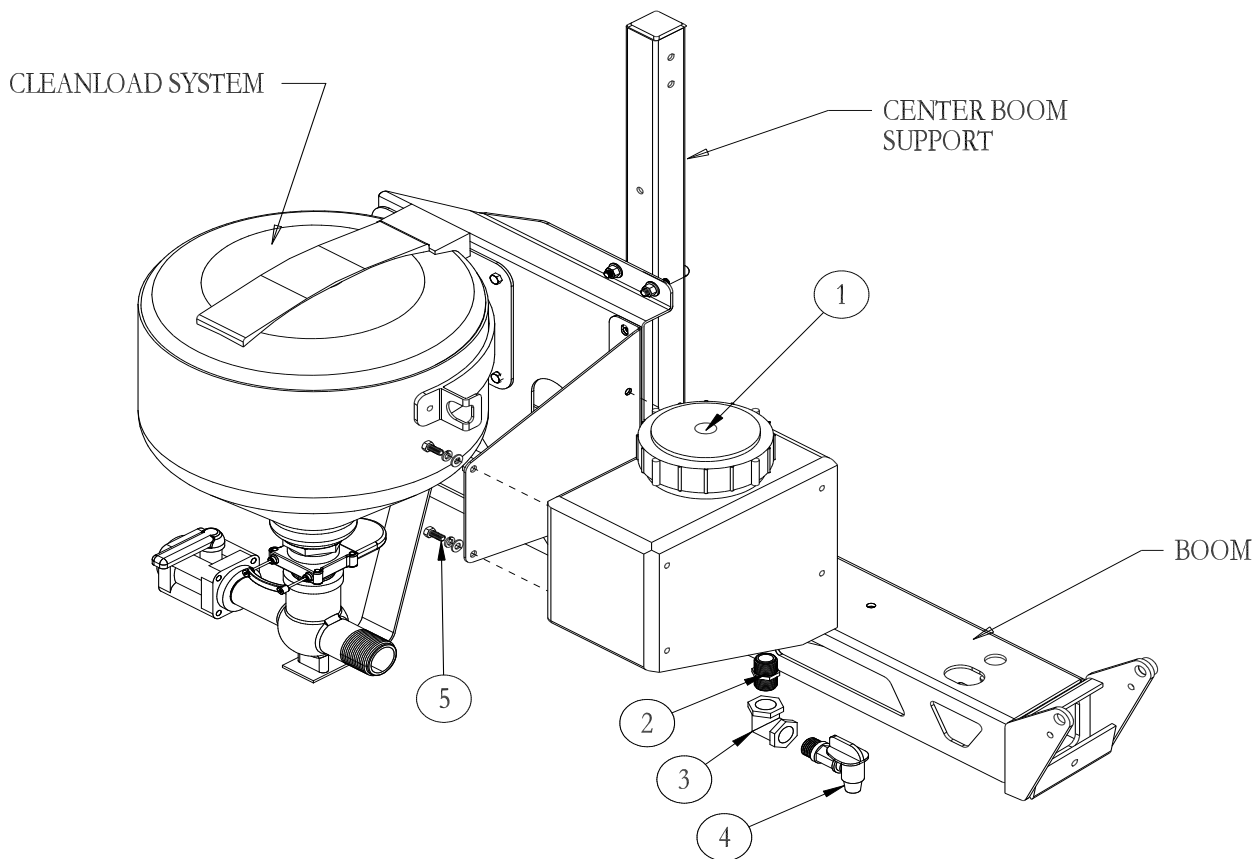

| REF# | PART#         | DESCRIPTION                                   | QUANTITY |
|------|---------------|---|----------|
| 1    | 10-234        | Wash Tank                                     | 1        |
| 2    | 16-158        | Close Nipple                                  | 1        |
| 3    | 16-151        | Elbow   | 1        |
| 4    | 16-960        | Spigot  | 1        |
| 5    | HB-516-18-075 | Hex Bolt, $\frac{5}{16}$ - 18 x $\frac{3}{4}$ | 4        |
|      | HWL-516       | Lockwasher, $\frac{5}{16}$                    | 4        |
|      | HW-516        | Flat Washer, $\frac{5}{16}$                   | 4        |

1. Fresh Water Wash Tank mounts on the rear of all the machines.
2. The Bracket is already attached to the Super Boom center boom post.
3. Install the nipple (Ref 2), elbow (Ref 3) and spigot (Ref 4) into the bottom of wash tank (Ref 1). Use thread tape on all threads.
4. Mount the tank onto the mount bracket using four  $\frac{5}{16}$  x  $\frac{3}{4}$  bolts, washers and lockwashers. Tighten.
5. Rinse tank with clear water and check for leaks around fittings.

**⚠ WARNING**

**This tank is for fresh clear water ONLY. Do not put chemicals in this tank.**



# 10-653 FRESH WATER WASH TANK - FRONT MOUNT

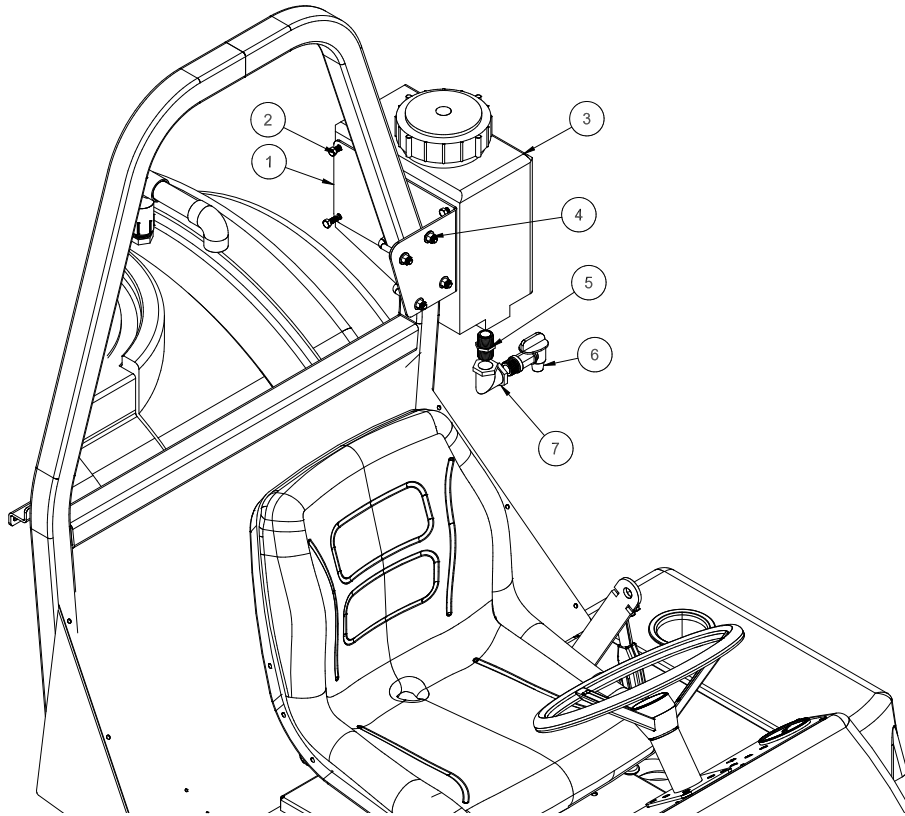

| REF# | PART#         | DESCRIPTION                              | QUANTITY |
|------|---------------|--|----------|
| 1    | 10-652        | Mount Plate                              | 1        |
| 2    | HB-516-18-075 | Bolt $\frac{5}{16}$ - 18 x $\frac{3}{4}$ | 4        |
|      | HWL-516       | Lockwasher $\frac{5}{16}$                | 4        |
|      | HW-516        | Washer $\frac{5}{16}$                    | 4        |
| 3    | 10-234        | Wash Tank                                | 1        |
| 4    | 17-537        | Square U-Bolt                            | 2        |
| 5    | 16-158        | Close Nipple                             | 1        |
| 6    | 16-151        | Elbow                                    | 1        |
| 7    | 16-960        | Spigot                                   | 1        |

1. Fresh Water Wash Tank mounts on the left side ROPs.
2. Mount the wash tank (Ref 3) onto the mount bracket (Ref 1) using four  $\frac{5}{16}$  x  $\frac{3}{4}$  bolts, washers and lockwashers (Ref 2). Tighten.
3. Install the nipple (Ref 5), elbow (Ref 6) and spigot (Ref 7) into the bottom of wash tank (Ref 1). Use thread tape on all threads.
4. Mount the tank Assembly to the left side ROPs with u-bolts (Ref 4). Tighten.
5. Rinse tank with clear water and check for leaks around fittings.

**⚠ WARNING**

This tank is for fresh clear water ONLY. Do not put chemicals in this tank.

# 15-619 CHEMICAL CLEAN-LOAD SAFE FILL SYSTEM

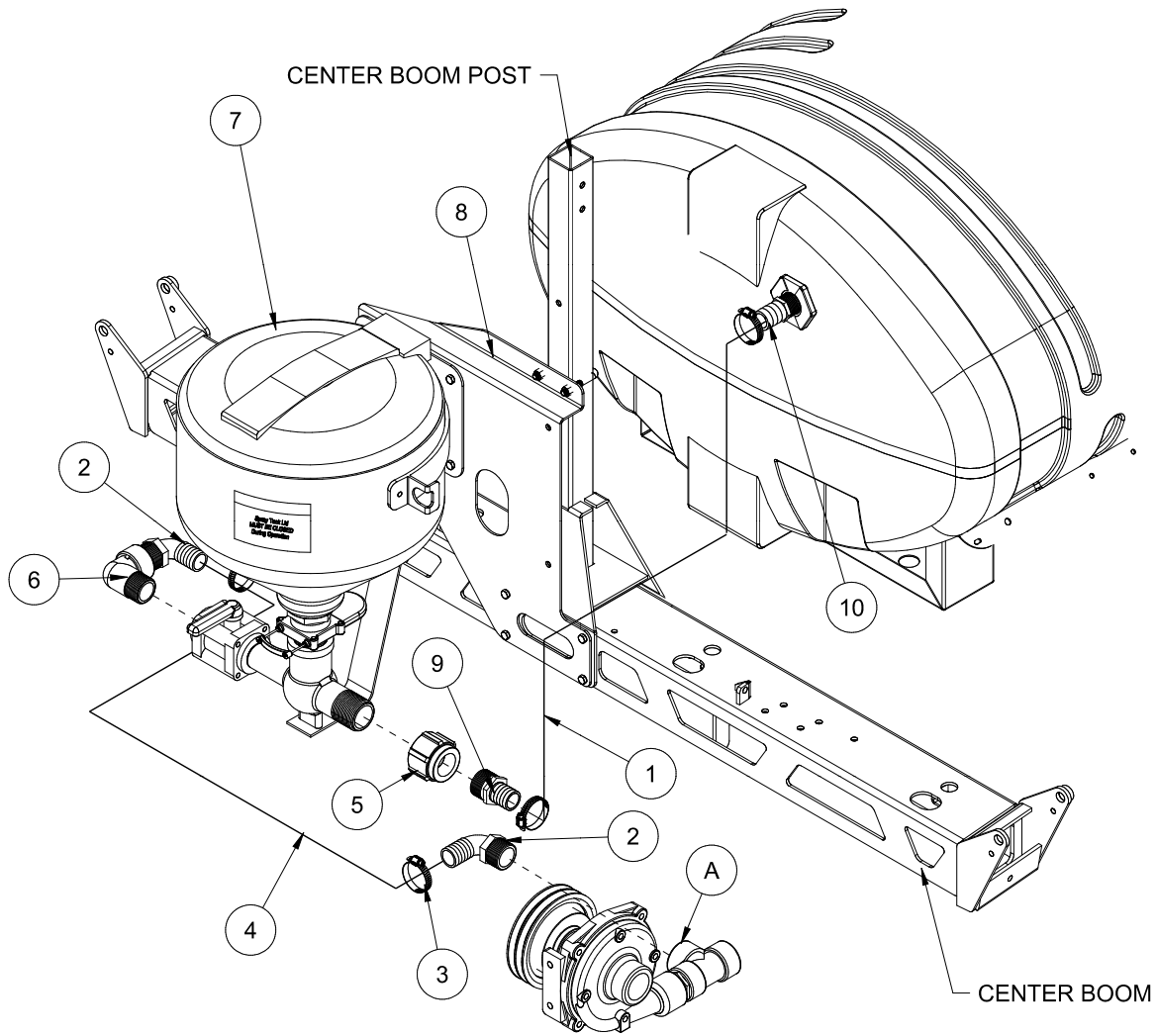

Accessories

| REF# | PART #          | DESCRIPTION                        | QUANTITY |
|------|-----------------|------------------------------------|----------|
| 1    | 8897-46         | 1 1/4" Discharge Hose 46"          | 1        |
| 2    | 16-156          | 90° Hose Barb                      | 2        |
| 3    | 18-116          | Hose Clamp                         | 4        |
| 4    | 8897-113        | 1 1/4" Discharge Hose 113"         | 1        |
| 5    | 18-391          | Coupling                           | 1        |
| 6    | 16-972          | Street Elbow                       | 1        |
| 7    | 15-620          | Cleanload Assembly                 | 1        |
|      | 25-389          | Decal, Tank Lid                    | 1        |
|      | HBFL-516-18-075 | Flange Bolt, 5/16 - 18 x 3/4       | 4        |
|      | HNFL-516-18     | Flange Lock Nut, 5/16 - 18         | 4        |
| 8    | 17-660          | Clean Load Mount (comes with boom) | 1        |
| 9    | 16-161          | Straight Fitting                   | 1        |
| 10   | 16-159          | Fitting                            | 1        |

# 15-619 CHEMICAL CLEAN-LOAD INSTALLATION INSTRUCTIONS

1. Make sure sprayer tank is empty and flush all chemical residue from sprayer. Always wear protective clothing, goggles and gloves.
2. Remove plug from tee on spray pump (Ref A).
3. Install one of the 90° fittings (Ref 2), should point to the back of the machine.
4. Install 113" of 1 1/4" discharge hose (Ref 4) onto the elbow on the pump that points back and tighten hose clamp (Ref 3).
5. Route the 113" hose to the back of the sprayer so it connects over the top of the left boom support tube.
6. Mixer Mount (Ref 8) is already installed on boom center post.
7. Mount Cleanload Assembly (Ref 5) onto mixer mount using 5/16 x 3/4 flange bolts and flange nuts. Tighten.
8. Install 18-391 reducer coupling (Ref 4) onto outlet side. Then a 16-161 fitting (Ref 9) into the coupling. Tighten fittings so that the elbow in the valve is pointing up and forward.
9. Remove the plug from the top back of the spray tank and install a 16-159 hose barb (Ref 10) and tighten.
10. Now the 46" hose (Ref 1) can be installed from the tank to the outlet fitting. Tighten with hose clamps.
11. The hose from the spray pump can be connected to the inlet fitting and tightened with hose clamps.
12. Make sure all hardware, fittings and clamps are tight. Add about 25 gallons of water to the spray tank. Start sprayer and circulate water through system to check for leaks.
13. Be sure to read start up, loading and shutdown instructions for Cleanload Assembly before using with chemicals. When working with chemicals **Always** wear protective clothing, goggles and gloves.

**SPRAY TANK LID MUST BE CLOSED WHEN USING CLEANLOAD.**

## TROUBLE SHOOTING

| Symptom                                | Corrective Action   |
|--|---|
| Low education rate                     | Check pump pressure and flow. Cleanload Eductor performance is based on flow and pressure to the system. Note requirements for high education rates.<br><br>Increase outlet hose size back to tank. |
| Plugged or clogged bottle rinse nozzle | Disassemble rotary portion of nozzle from lower valve assembly and back flush until nozzle ports are clear of debris.   |
| Plugged or clogged tank rinse nozzle   | Disassemble rotary portion of nozzle from NPT hose barb and back flush until nozzle ports are clear of debris. Remove screen and flush with water to clear away foreign material.                   |
| Fitting leaks                          | Check for cracks in fitting. Replace fitting if necessary.<br><br>Disassemble and add more joint seal in compound if leak occurs on threads.  |

# 15-620 CHEMICAL CLEAN-LOAD® PARTS DRAWING

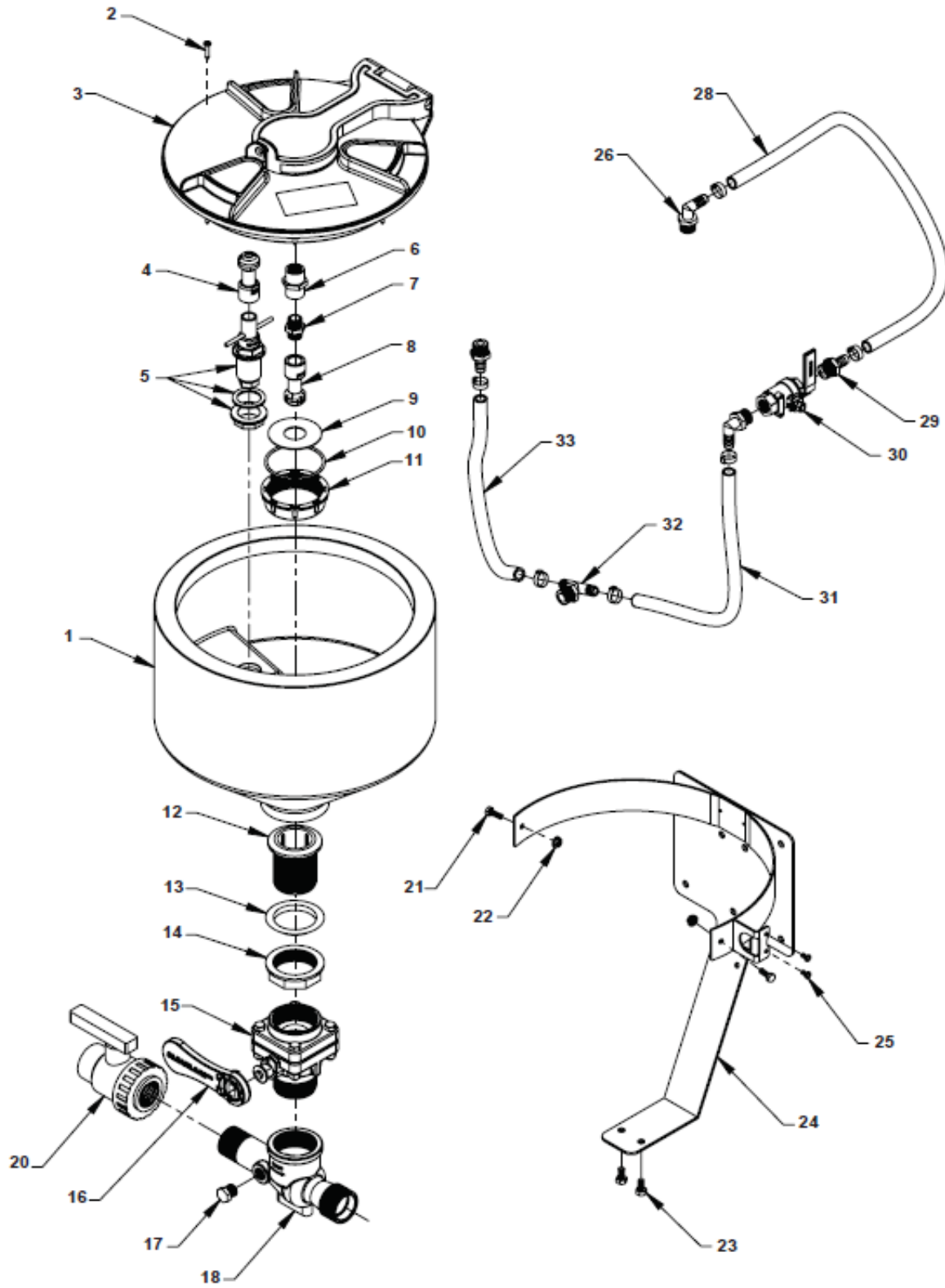

Accessories

## 15-620 CHEMICAL CLEAN-LOAD® PARTS LIST

| REF# | PART#     | DESCRIPTION                    | QUANTITY |
|------|-----------|--------------------------------|----------|
| 1    | 15-620-21 | Tank                           | 1        |
| 2    |           | Screw, #6 x 1"                 | 8        |
| 3    | 15-620-02 | Tank Lid                       | 1        |
| 4    | 15-620-22 | ProClean Container Nozzle      | 1        |
| 5    | 15-620-23 | ProClean Push Valve Assembly   | 1        |
|      | 15-620-19 | Tank Rinse                     | 1        |
|      | 15-620-20 | Gasket, 1"                     | 1        |
| 6    |           | 1/2 x 1/2 FNPT Coupler         | 1        |
| 7    |           | 1/2 x 1/2 Thread Nipple        | 1        |
| 8    |           | ProClean Tank Wash Nozzle      | 1        |
| 9    |           | Splash Retainer                | 1        |
| 10   |           | O-ring Breather                | 1        |
| 11   |           | Nut, Breather                  | 1        |
| 12   | 15-620-18 | Drain Head, 2"                 | 1        |
| 13   | 15-620-17 | Gasket 2", Tapered             | 1        |
| 14   | 15-620-16 | Locking Ring, 2"               | 1        |
| 15   | 15-620-12 | Ball Valve                     | 1        |
|      | 15-620-15 | Gasket 2" BSP                  | 1        |
| 16   | 15-620-13 | Handle, Clean-load             | 1        |
| 17   |           | 1/2 MNPT PP Hex Plug           | 1        |
| 18   | 15-620-04 | Clean-load Eductor             | 1        |
| 20   | 15-620-14 | Ball Valve, 1 1/4 Single Union | 1        |
| 21   |           | Screw                          | 2        |
| 22   |           | Flange Nut                     | 2        |
| 23   |           | Hex Head Screw                 | 2        |
| 24   | 15-620-01 | Frame, Back Mount              | 1        |
| 25   |           | Phillips Head Screw            | 2        |
| 26   | 15-620-11 | Elbow 1/2"                     | 2        |
| 28   | 15-620-08 | Hose, Tank Rinse, 1/2" EPDM    | 1        |
| 29   | 15-620-09 | HB, 1/2 MNPT x 1/2 HB          | 2        |
| 30   | 15-620-10 | Valve, SS Tank Rinse           | 1        |
| 31   | 15-620-06 | Hose, Valve Feeder, 1/2" EPDM  | 1        |
| 32   | 15-620-05 | HB Tee, 1/2 MNPT to 1/2 HB     | 1        |
| 33   | 15-620-07 | Hose, Bottle Rinse, 1/2" EPDM  | 1        |

# OPERATING INSTRUCTION

## STARTUP

1. All Clean-load valves must be closed prior to starting: inlet ball valve, knife valve and hopper rinse ball valve.
2. Open lid to check for foreign objects which may hinder performance or contaminate the system.
3. Close and lock lid by turning cover clockwise.
4. Divert pump flow to Clean-load inlet line. A pressure of 30 PSI minimum and 150 PSI maximum must be used. Highest pressures increase eduction rate and available wand suction.
5. Turn inlet ball valve on (yellow handle).
6. Open knife valve, located on the bottom of hopper, by pushing handle in (red handle).
7. Unlock and open lid slowly by turning cover counterclockwise.

## LOADING LIQUID OR POWDERED CHEMICAL INTO HOPPER

8. Pour required amount of chemical into hopper. Avoid splashing liquids or powdered chemicals outside of hopper.
9. Rinse empty chemical containers if applicable. Place container opening over container rinse valve and press down. This will activate the rinse valve and rinse container.
10. Rinse Clean-load hopper. Close and lock lid by turning cover clockwise. Release the safety locking band on the hopper rinse ball valve and turn on for 20 seconds. Close ball valve and return locking band to locked position.
11. Open lid and inspect for chemical residue. Repeat step 10 as necessary.
12. Close knife valve by pulling red handle out towards you. Turn inlet (yellow handle) off.

## LOADING LIQUID AND/OR POWDERED CHEMICAL WITH SUCTION LANCE

**Note: Lance suction is dependent upon eductor pressure and flow. For best results, use highest pressure available up to 150 PSI maximum.**

8. Insert lance body with o-ring into eductor until the o-ring is sealed.
9. Use the free end of the lance to pierce bag or container to vacuum powdered or liquid chemical.
10. Rinse lance. Place lance end into a clean container of water to rinse lance assembly.
11. Remove lance body from eductor and drain any remaining fluid into hopper.
12. Close knife valve (red handle). Turn inlet valve (yellow handle) off.

## SHUTDOWN

1. Ensure that:
  - All valves are closed. Be sure to close knife valve first. (Close by pulling red handle out towards you.)
  - Chemical residue has been cleaned.
  - Hopper lid is closed and locked by turning cover clockwise.
2. Divert pump flow back to normal operation.

# DECAL LOCATION

## ⚠ WARNING

If Safety Decals\*\* have been damaged, removed, become illegible or parts replaced without decals, new decals must be applied. New decals are available from your authorized distributor.

This is a list of decals located on the Spray Star 1200 diesel. Part number, description and location will help in reordering decals.

|     |        |                         |
|-----|--------|-------------------------|
| A   | 20-705 | Decal, Tank Volume      |
| B   | 20-707 | Decal, Rear Tank Volume |
| C** | 15-463 | Decal, Spray Pump       |
| D   | 20-706 | Decal, Spray Star 1200  |
| E** | 20-866 | Decal, Control Panel    |
| F** | 51-184 | Decal, Park Brake       |
| G** | 15-719 | Decal, Speed Control    |
| H** | 25-298 | Decal, Warning Hot      |
| I** | 25-371 | Decal, Diesel           |
| J** | 25-286 | Decal, Pinch Point      |
| K   | 25-356 | Decal, Tire Pressure    |
| L   | 25-373 | Decal, Smithco          |
| M   | 25-370 | Decal, 88 dBA           |
| N   | 27-077 | Decal, Smithco          |
| O** | 27-093 | Decal, Hydraulic Oil    |
| P** | 25-277 | Decal, Battery          |
| Q** | 25-321 | Decal, Diesel Fuel      |

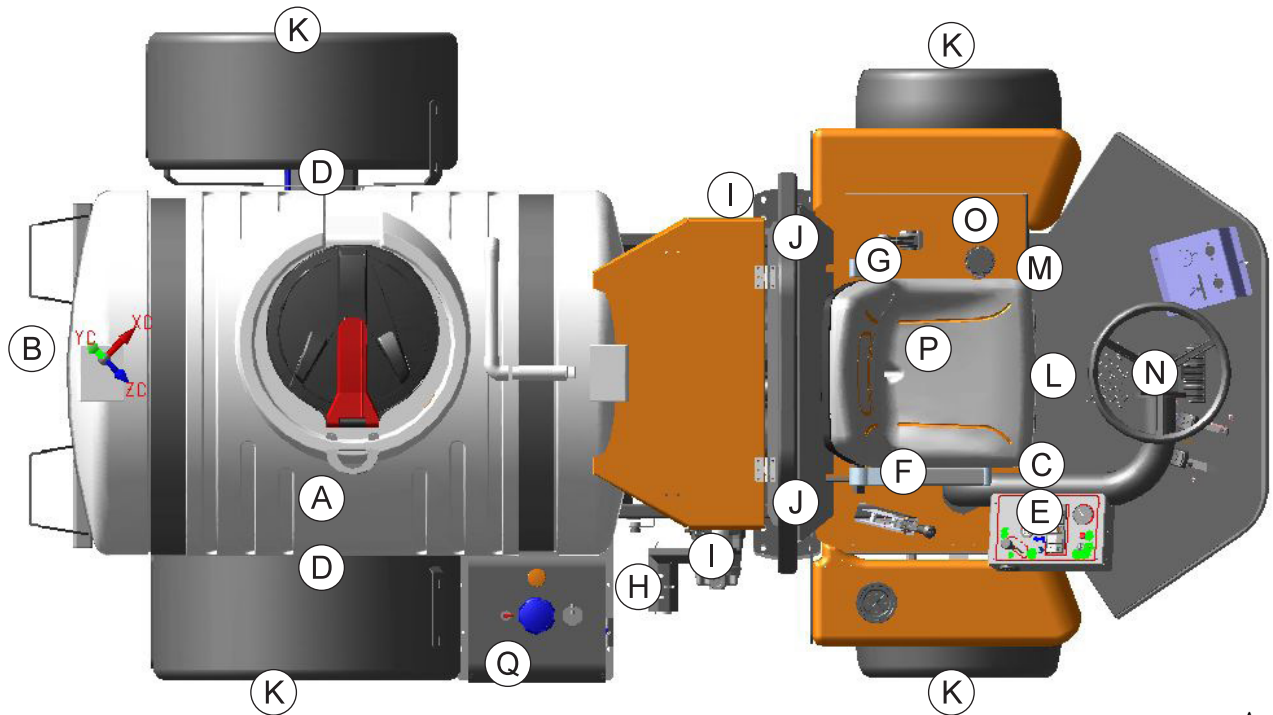

# QUICK REFERENCE REPLACEMENT PARTS

## REPLACEMENT FILTERS

|           |                                |
|-----------|--------------------------------|
| 26-016    | Hydraulic Oil Filter Assembly  |
| 23-031    | Oil Filter Replacement Element |
| 30-042-09 | Engine Oil Filter              |
| 30-042-05 | Air Cleaner Cartridge          |
| 30-042-08 | Fuel Filter Element            |

## REPLACEMENT BELTS

|           |                        |
|-----------|------------------------|
| 20-889    | Spray Pump V-Belt L444 |
| 30-042-11 | Fan Belt               |

## SEAL KITS

|           |                              |
|-----------|------------------------------|
| 15-301    | Power Steering Orbital Motor |
| 15-301-01 | Seal Kit                     |
| 15-839    | Hydraulic Cylinder           |
| 15-839-01 | Seal Kit                     |
| 76-238    | Wheel Motors                 |
| 14-080    | Seal Kit                     |
| 76-638    | Hydrostatic Pump             |
| 77-239-23 | Seal Kit                     |
| 76-197    | Gear Pump                    |
| 76-197-08 | Seal Kit                     |

## FLUIDS

|                 |   |
|-----------------|---|
| Engine Oil      | SAE 10W-40 API Service SJ or higher Motor Oil |
| Hydraulic Fluid | SAE 10W-40 API Service SJ or higher Motor Oil |

## OTHER PARTS

|           |                                  |
|-----------|----------------------------------|
| 16-953    | Hinged Cover On Tank with Gasket |
| 16-953-01 | Gasket For Cover                 |
| 16-169    | Strainer Basket                  |
| 15-818    | #75 Fitting O-ring               |
| 15-817    | #50 Fitting O-ring               |
| 20-663    | Tank Lid Gasket                  |
| 13-488    | Key Switch                       |
| 8-709     | Key Set                          |



# The Smithco Commercial Products Two-Year Limited Warranty

Smithco, Inc. (Smithco) warrants your 2016 or newer Smithco Commercial Product (“Product”) purchased after October 1, 2016 to be free from defects in materials or workmanship for the period of time listed below. Where a warrantable condition exists, Smithco will repair the Product at no cost to you including diagnosis, labor (at the Smithco standard labor rate, subject to the Smithco flat rate schedule), and parts.

## Warranty Duration is:

- (1) Two years, 1500 operational hours\* from the date of delivery to the original purchaser or Five years from the date of original manufacturer of the product, whichever occurs first. (\*Products equipped with hour meter).
- (2) Products used in rental situations are covered for 90 days from date of delivery to original user/renter.

## Owner Responsibilities:

As the Product owner, you are responsible for required maintenance and adjustments stated in your Owner’s Manual. Failure to perform required maintenance and adjustments can be grounds for disallowing a warranty claim. **You are particularly responsible to train all present and future operators of this product on the safe operation of this product at your location.**

## Instructions for Obtaining Warranty Service:

You are responsible for notifying the Authorized Smithco Products Distributor from whom you purchased the Product as soon as you believe a warrantable condition exists and not later than 30 days from discovery of the condition.

If you need help locating an Authorized Smithco Distributor, or if you have questions regarding your warranty rights or responsibilities, you may contact us at:

Smithco Product Support Department  
200 West Poplar Ave.  
Cameron, Wisconsin 54822  
Telephone: 800-891-9435 E-Mail: [ProductSupport@Smithco.com](mailto:ProductSupport@Smithco.com)

## Maintenance Parts:

Parts scheduled for replacement as required maintenance (“Maintenance Parts”), are warranted for the period of time up to the scheduled replacement time for that part.

## Items/Conditions Not Covered:

Not all product failures or malfunctions that occur during the warranty period are defects in materials or workmanship. The items/conditions listed below are not covered by this warranty:



Product failures which result from the use of non-Smithco replacement parts, or from installation and use of add-on, modified, or unapproved accessories are not covered.



Product failures which result from failure to perform required maintenance and/or adjustments are not covered.



Product failures that result from operating the Product in an abusive, negligent or reckless manner are not covered.



This warranty does not apply to parts subject to consumption through use, unless found to be defective. Examples of parts which are consumed, or used up, during normal Product operation include, but are not limited to: blades, tines, teeth, scarifiers, rakes, plates, wear plates, castor wheels, tires, batteries, filters, belts, nozzles, etc.



This warranty does not apply to failures caused by outside influence. Items considered to be outside influence include, but are not limited to, weather, storage practices, contamination, use of unapproved coolants, lubricants, additives, or chemicals, etc.



This warranty does not apply to normal “wear and tear” items. Normal “Wear and Tear” includes, but is not limited to, damage to seats due to wear or abrasion, worn painted surfaces, scratched decals or windows, etc.



Smithco may require the return of failed parts or components in order to determine the validity of any warranty claim.



Smithco will not be obligated to replace components of other manufacturers if inspection by the original component manufacturer indicates that failure was due to normal wear and tear, expected consumption through use or improper care or service.

#### **Other Legal Disclaimers:**

The above remedy for product defects through repair or replacement by an authorized Smithco distributor or dealer is the purchaser’s sole remedy for any defect. This warranty gives you specific legal rights, and you may also have other rights which vary from state to state.

**THERE ARE NO OTHER EXPRESS WARRANTIES OTHER THAN THOSE SET FORTH ABOVE. ALL IMPLIED WARRANTIES OF MERCHANTABILITY AND FITNESS FOR USE ARE LIMITED TO THE DURATION OF THE LIMITED WARRANTIES CONTAINED HEREIN.**

Some states may not allow limitations on how long an implied warranty lasts, so the above limitation may not apply to you.

**THE SMITHCO COMPANY IS NOT LIABLE FOR INDIRECT, INCIDENTAL OR CONSEQUENTIAL DAMAGES IN CONNECTION WITH THE USE OF THE PRODUCT, INCLUDING ANY COST OR EXPENSE OF PROVIDING A SUBSTITUTE PRODUCT OR SERVICE DURING PERIODS OF MALFUNCTION OR NON-USE.**

Some states may not allow the exclusion of indirect, incidental or consequential damages, so the above exclusion may not apply to you.

**Smithco neither assumes, nor authorizes any person to assume for it, any other liability in connection with the sale or use of this product.**

