

Parts & Service

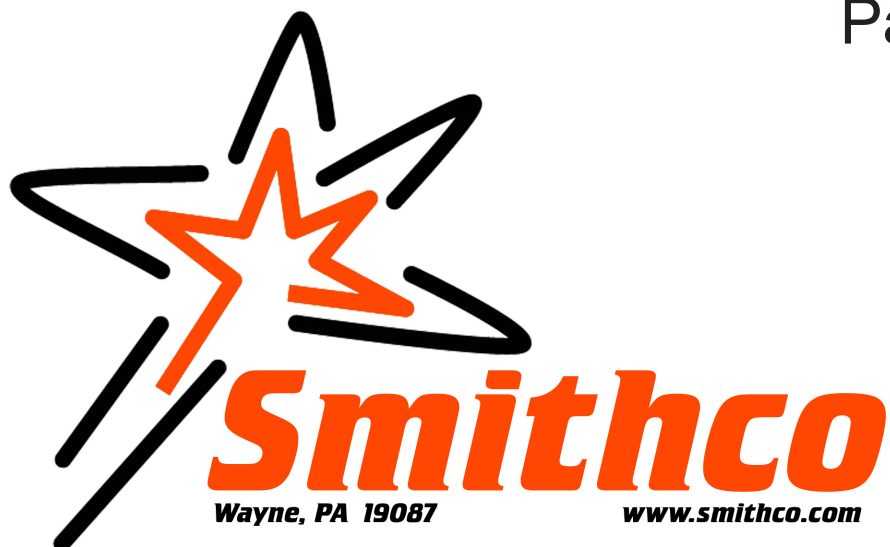

Sand Star CVT Mechanical

41-000-A

SN 41001

Product Support:

Hwy 55 & Poplar Ave; Cameron WI 54822

1-800-891-9435 productsupport@smithco.com

CONTENTS

Introduction	Introduction..... 1-3
	Introduction 1
	Safe Practices 2
	Specifications 3
Service	Service..... 4-9
	Maintenance 4-7
	Adjustments 8-9
	Storage 9
Diagrams	Diagrams 10-11
	Wiring Diagram 10
	Parts..... 12-29
	Main Frame 12-13
	Dash Panel 14-15
	Front Fork 16-17
	Seat Panel 18-19
	Foot Pedal Linkage 20-23
	Brake Linkage..... 24-25
	Rear Axle and Engine 26-27
	Center Rake Lift..... 28
	Rear Rake lift..... 29
	Accessories 30-70
	41-020 Light Kit 30-31
13-644 Aluminum Plow 32-33	
41-019 Construction Leveling Blade..... 34-35	
41-021 Sand Cultivator - Vertical Blades 36-37	
41-022 Sand Cultivator-Spring Tine 38-39	
41-023 Infield Scarfier 40-41	
42-391Q 72" ProBrush Tournament Rake 42-45	
42-392Q 84" ProBrush Tournament Rake 44-47	
42-130Q 84" Steel Tournament Rake 46-53	
42-132Q 72" Steel Tournament Rake 54-57	
13-758Q Rake with Finishing Blades 58-59	
45-503 84" Rake Assembly 60-61	
45-511 Flex Rake Assembly 62-63	
13-740 Sand Rake Brush Kit 64	
13-298Q Fan Rake 65	
13-319Q Fan Rake Kit..... 66	
26-007Q Professional Infield Finisher 67	
43-002Q Flex Field Finisher w/ Brush 68-69	
26-008Q Flex Action Field Finisher 70-71	
41-099 Drag Mat & Carrier 72-73	
Decals..... 74	
Reference	Warranty 74

Thank you for purchasing a **Smithco** product.

Read this manual and all other manuals pertaining to the Bunker Rake carefully as they contain safety, operating, assembly and maintenance instructions. Failure to do so could result in personal injury or equipment damage.

Keep manuals in a safe place after operator and maintenance personnel have read them. Right and left sides are from the operator's seat, facing forward.

WARNING

Failure to follow cautious operating practices can result in serious injury to the operator or other persons. The owner must understand these instructions, and must allow only trained persons who understand these instructions to operate this vehicle.

All **Smithco** machines have a Serial Number and Model Number. Both numbers are needed when ordering parts. Serial number tag is located on left rear ROPs mount post. Refer to engine manual for placement of engine serial number.

For product and accessory information, help finding a dealer, or to register your product please contact us at www.Smithco.com.

Information needed when ordering replacement parts:

1. Model Number of machine
2. Serial Number of machine
3. Name and Part Number of part
4. Quantity of parts

For easy access record your Serial and Model numbers here.

SMITHCO WAYNE, PENNSYLVANIA 19087 USA 610-688-4009 Fax 610-688-6069			
SERIAL NO. <input type="text"/>	kW/hp <input type="text"/>	DATE OF MFG. <input type="text"/>	
MODEL NO. <input type="text"/>	lb/kg Empty <input type="text"/>	lb/kg Full <input type="text"/>	

SMITHCO CUSTOMER SERVICE 1-800-891-9435

SAFE PRACTICES

1. It is your responsibility to read this manual and all publications associated with this machine (engine, accessories and attachments).
2. Never allow anyone to operate or service the machine or its attachments without proper training and instructions. Never allow minors to operate any equipment.
3. Learn the proper use of the machine, the location and purpose of all the controls and gauges before you operate the equipment. Working with unfamiliar equipment can lead to accidents.
4. Wear all the necessary protective clothing and personal safety devices to protect your head, eyes, ears, hands and feet. Operate the machine only in daylight or in good artificial light.
5. Inspect the area where the equipment will be used. Beware of overhead obstructions and underground obstacles. Stay alert for hidden hazards.
6. Never operate equipment that is not in perfect working order or without decals, guards, shields, or other protective devices in place.
7. Never disconnect or bypass any switch.
8. Carbon monoxide in the exhaust fumes can be fatal when inhaled, never operate a machine without proper ventilation.
9. Fuel is highly flammable, handle with care.
10. Allow engine to cool before fueling.
11. Keep engine clean. Allow the engine to cool before storing and always remove the ignition key.
12. After engine has started, machine must not move. If movement is evident, the neutral mechanism is not adjusted correctly. Shut engine off and readjust so the machine does not move when in neutral position.
13. Never use your hands to search for oil leaks. Hydraulic fluid under pressure can penetrate the skin and cause serious injury.
14. This machine demands your attention. To prevent loss of control or tipping of the vehicle:
 - A. Use extra caution in backing up the vehicle. Ensure area is clear.
 - B. Do not stop or start suddenly on any slope.
 - C. Reduce speed on slopes and in sharp turns. Use caution when changing directions on slopes.
 - D. Stay alert for holes in the terrain and other hidden hazards.
15. Before leaving operator's position for any reason:
 - A. Disengage all drives.
 - B. Lower all attachments to the ground.
 - C. Shut engine off and remove the ignition key.
16. Keep hands, feet and clothing away from moving parts. Wait for all movement to stop before you clean, adjust or service the machine.
17. Keep the area of operation clear of all bystanders.
18. Never carry passengers.
19. Stop engine before making repairs/adjustments or checking/adding oil to the crankcase.
20. Use parts and materials supplied by **Smithco** only. Do not modify any function or part.

These machines are intended for professional maintenance on golf courses, sports turf, and any other area maintained turf and related trails, paths and lots. No guaranty as to the suitability for any task is expressed or implied.



MECHANICAL SAND STAR SPECIFICATIONS

WEIGHTS AND DIMENSIONS

Length	68" (1.73 m)
Width	61" (1.55 m)
Height	50" (1.3 m)
Wheel Base	51" (1.3 m)
Ground Clearance	5.5" - 7" (13 -18 cm)
Weight	841 lbs. (381 kg)

SOUND LEVEL (EAR PROTECTION REQUIRED)

At Ear Level	85 dB
--------------	-------

ENGINE

Make	Briggs and Stratton
Model#	19L237
Type / Spec#	0319-F1
Horsepower	10 hp (7.46 kW)
Fuel	Minimum of 87 octane
Alternator	10 Amp

WHEELS & TIRE

Front: 20 X 10 - 10 Turf Tires 5 psi (.34 bar) Smithco # 52-120
Rear: 25 X 10 - 12 Turf Tires 5 psi (.34 bar) Smithco # 45-617

SPEED

Forward Speed	0 to 12 m.p.h. (0-19 kph)
Reverse Speed	0 to 5 m.p.h. (0-8 kph)

BATTERY

	Automotive Type SP 45
BCI Group	Size 45
Cold Cranking Amps	300
Ground Terminal Polarity	Negative (-)
Maximum Length	7.5" (19 cm)
Maximum Width	5" (12,7 cm)
Maximum Height	7.5" (19 cm)

FLUID CAPACITY

Fuel	3.8 quarts (3.6 liters)
80/90 wt Gear Lube	1.375 pt (.65 liters)
Engine Oil	1.75 pt (.83 liters)

ACCESSORIES

13-298Q Fan Rake	13-319 Fan Rake Kit
13-644 Aluminum Plow	13-758Q Rake with Finishing Blades
26-007Q Professional Infield Finisher	26-008Q Flex Action Field Finisher
41-019 Construction Leveling Blade	41-021 Sand Cultivator - Straight Blades
41-022 Sand Cultivator-Spring Tines	41-023 Sand Cultivator - Vertical Blades
41-099-A Drag Mat w/ Carrier	42-130Q 84" Mild Steel Tournament Rake
42-132Q 72" Mild Steel Tournament Rake	42-391Q 72" Pro Brush Tournament Rake
42-392Q 84" Pro Brush Tournament Rake	43-002Q Flex Action Field Finisher with Brush



MAINTENANCE

⚠ CAUTION

Before servicing or making adjustments to machine, stop engine and remove key from ignition.

⚠ IMPORTANT

Use all procedures and parts prescribed by the manufacturer's. Read the engine manual.

LUBRICATION

Use No. 2 General purpose Lithium Base Grease and lubricate every 100 hours. The Sand Star has seven grease fittings.

- A. Shift Relay
- B. LH Brake Relay
- C. Forward Pedal
- D. Reverse Pedal
- E. RH Brake Relay
- F. Gas Pedal
- G. Brake Pedal

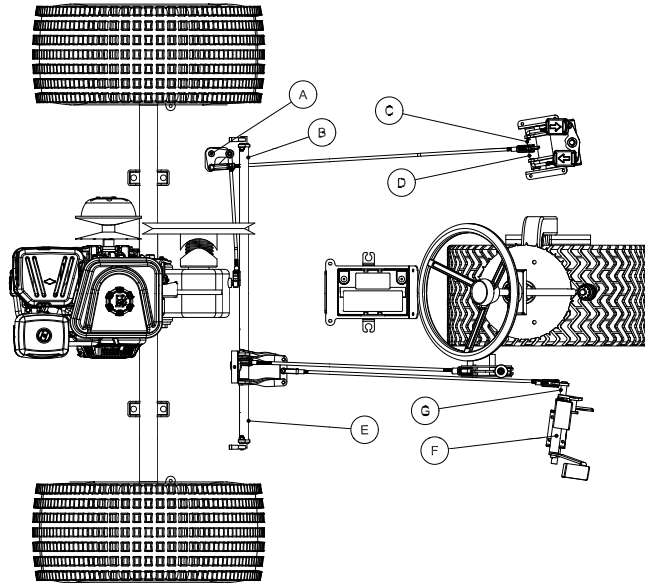

TOWING

When it is necessary to move the Sand Star without engine running, make sure park brake is released and pedals are in neutral position. If the machine must be moved a considerable distance, transport it on a truck or trailer.

TIRE PRESSURE

Caution must be used when inflating a low tire to recommended pressure. Over inflating can cause tires to explode. Tires should be 5 psi (0.34 bar). Improper inflation will reduce tire life considerably.

DAILY CHECKLIST

1. Check engine oil level in vehicle. Add as needed. DO NOT OVERFILL.
2. Check trap rake for loose or missing nuts, bolts, screws, etc., And tighten or replace as needed..
3. Check tire pressure. 5 psi (.34 bar)
6. Check electrical system for loose connections or frayed wiring, including battery cables. Replace any faulty equipment or tighten if loose.
7. Fill fuel tank. Allow engine to cool before fueling.

ENGINE

Change and add oil according to temperature chart below. Do not overfill. Use a high quality detergent oil classified "For Service SF, SG, SH, SJ or higher" SAE 30 oil. Use no special additives with recommended oils. Do not mix oil with gasoline.

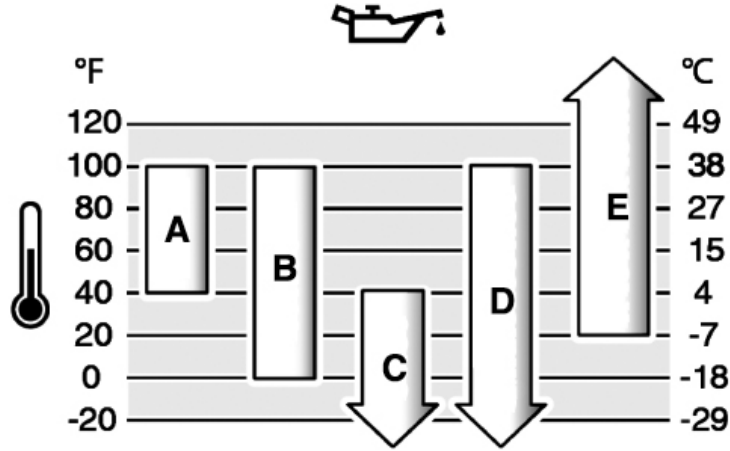

A	SAE 30 - Below 40 °F (4 °C) the use of SAE 30 will result in hard starting.
B	10W-30 - Above 80 °F (27 °C) the use of 10W-30 may cause increased oil consumption. Check the oil level frequently.
C	5W-30
D	Synthetic 5W-30
E	Vanguard® Synthetic 15W-50

Starting Temperature Range Anticipated Before Next Oil Change

Outdoor temperatures determine the correct oil viscosity for the engine. Use the chart to select the best oil for outdoor temperature range expected. Engines on most outdoor power equipment operate well with 5W-30 synthetic oil. For equipment operated in hot temperatures 15W-30 synthetic oil gives the best protection.

CAUTION

Before servicing or making adjustments to the machine, stop engine, set park break, block wheels and remove key from ignition.

IMPORTANT

Follow all procedures and **ONLY** use parts prescribed by the manufacturer. Read the engine manual before maintenance.

The suggested maintenance checklist is not offered as a replacement for the manufacturer's engine manual but as a supplement. You must adhere to the guidelines established by the manufacturer for warranty coverage. In adverse conditions such as dirt, mud or extreme temperatures, maintenance should be more frequent.

MAINTENANCE

WHEEL MOUNTING PROCEDURE

1. Turn machine off and remove key.
2. Block one of the other wheels.
3. Loosen nuts slightly on wheel to be removed.
4. Jack up machine being careful not to damage underside of machine.
5. Remove nuts. Remove wheel.
5. Place new wheel on hub lining up bolt holes.
6. Torque nuts to 64-74 ft/lb (87-100 Nm) using a cross pattern. Re-torque after first 8 hours and every 250 hours thereafter.
7. Lower machine to ground and remove blocks and jack.

BATTERY

Batteries normally produce explosive gases which can cause personal injury. Do not allow flames, sparks or any ignited object to come near the battery. When charging or working near battery, always shield your eyes and always provide proper ventilation.

Battery cable should be disconnected before using "Fast Charge".

Charge battery at 15 amps for 10 minutes or 7 amps for 30 minutes. Do not exceed the recommended charging rate. If electrolyte starts boiling over, decrease charging.

Always remove grounded (-) battery clamp first and replace it last. Avoid hazards by:

1. Filling batteries in well-ventilated areas.
2. Wear eye protection and rubber gloves.
3. Avoid breathing fumes when electrolyte is added.
4. Avoid spilling or dripping electrolyte.

⚠ WARNING

Battery Electrolyte is an acidic solution and should be handled with care. If electrolyte is splashed on any part of your body, flush all contact areas immediately with liberal amounts of water. Get medical attention immediately.

JUMP STARTING

⚠ WARNING

Use of booster battery and jumper cables. Particular care should be used when connecting a booster battery. Use proper polarity in order to prevent sparks.

To jump start (negative grounded battery):

1. Shield eyes.
2. Connect ends of one cable to positive (+) terminals of bottom post on solenoid first (A), then positive post of booster battery. (B).
3. Connect one end of other cable to negative (-) terminal of booster battery (C).
4. Connect other end of cable (D) to engine block on unit being started.

To prevent damage to other electrical components on unit being started, make certain that engine is at idle speed before disconnecting jumper cables.

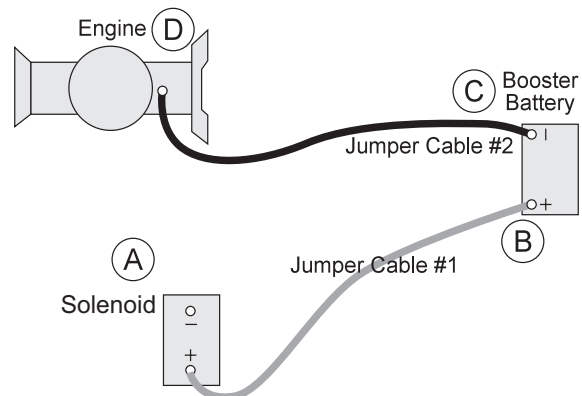

SERVICE INTERVALS

After First 5 hours:

- Check engine oil.

After First 8 hours or daily

- Check engine oil.

- Clean area around muffler and controls.

- Clean air intake grille.

After 25 hours:

- Clean air filter.

- Clean pre-cleaner.

After 50 hours:

- Check wheel lug nuts torque to 64-74 ft/lb (87-100Nm).

- Inspect tires - Check air pressure 5 psi (.34 bar)

- Change engine oil.

- Service exhaust system.

Annually:

- Replace the spark plug.

- Replace the air filter. Replace the Pre-cleaner.

ADJUSTMENTS

TO ADJUST GAS PEDAL THROTTLE CABLE

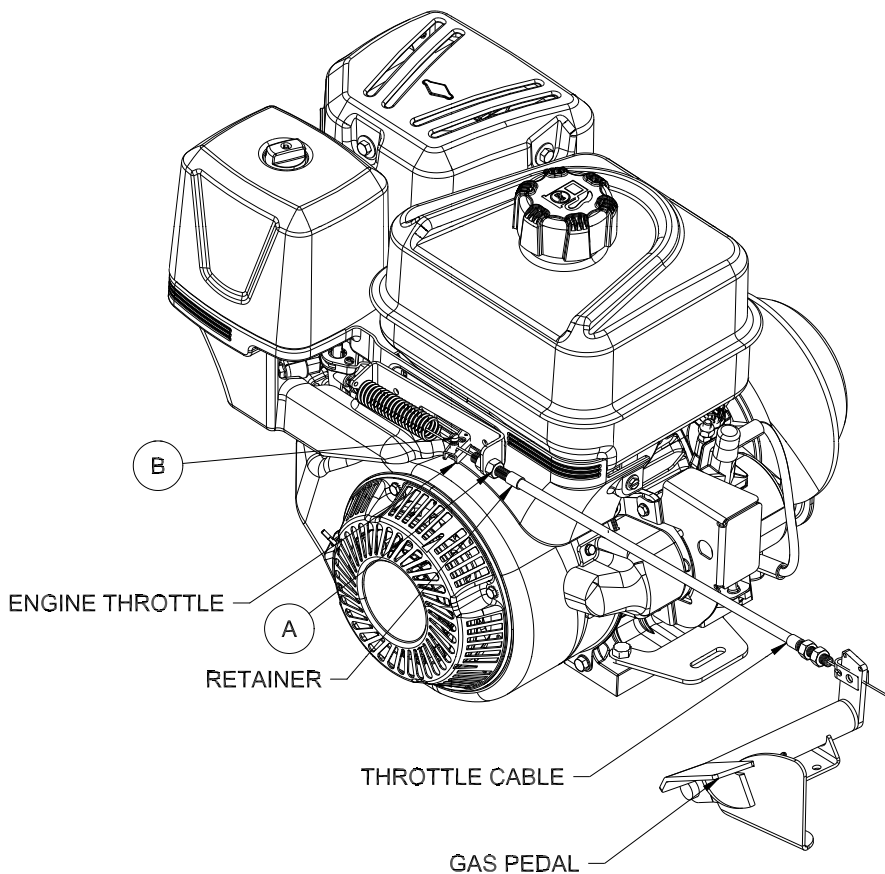

1. Jack up unit so that all drive wheel are off the ground. (Use jack stands)
2. Start the engine, make certain that the gas pedal is in the idle position(1200 ± 100 RPM).
3. Engine speed must increase as soon as the foot pedal begins to move in either direction. At the full forward position, the engine RPM must be $3300\text{RPM} \pm 100$.
4. When throttle is running wide open. The throttle stop must contact the gas pedal.
5. Minor adjustment can be made by backing out (unscrewing) Retainer (Ref A) until you reach full engine RPM with the gas pedal fully depressed in the forward position. Be sure to recheck after the nuts are fully tightened.

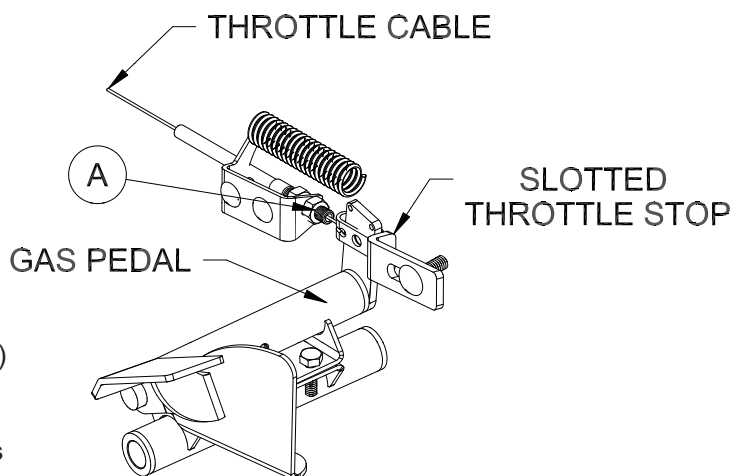

6. Major adjustment needs to be made by pulling the slack out of the cable. Loosen the screw in the wire block(Ref B) on the engine that is clamped onto the end of the cable and sliding it up to the cable block that is through the throttle plate. Do not let the throttle plate move to increase idle speed. Tighten the screw.
7. Test run to determine that there is no binding and that engine idle speed is 1200 RPM and that it is 3300RPM at full forward position of the foot pedal.

PARK BRAKE

The park brake is located on the right hand side of the machine and operates both rear wheels. Push forward to engage and Pull lever back to disengage. To adjust park brake, turn the knob on the end of the handle.

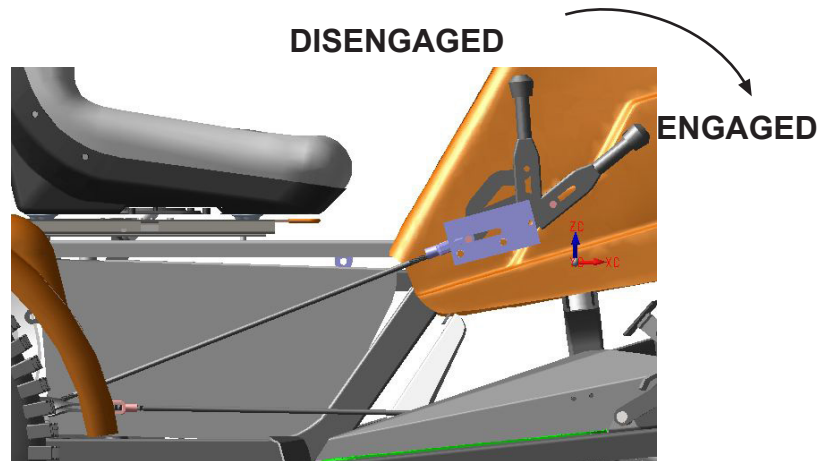

STORAGE

When storing, remove the key from the key switch to avoid unauthorized persons from operating machine.

1. Before storing clean machine thoroughly.
2. Check bolts and nuts, tighten as necessary.
3. Make all repairs that are needed and remove any debris.
4. Remove the battery, adjust the electrolyte level and recharge it. Store the battery in a dry, dark place.
5. Store in a clean and dry area, but NOT near a stove, furnace or water heater which uses a pilot light or any device that can create a spark.
6. If machine is stored for more then 30 days, the fuel system should either be completely drained or treated with a fuel stabilizer. This will aid in the prevention of gum and tarnish build up inside e the system along with internal essential carburetor parts.

WIRING DRAWING

Diagrams

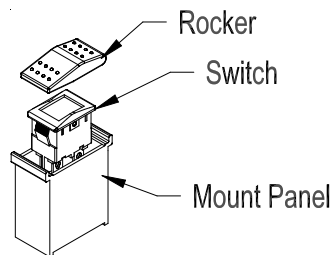
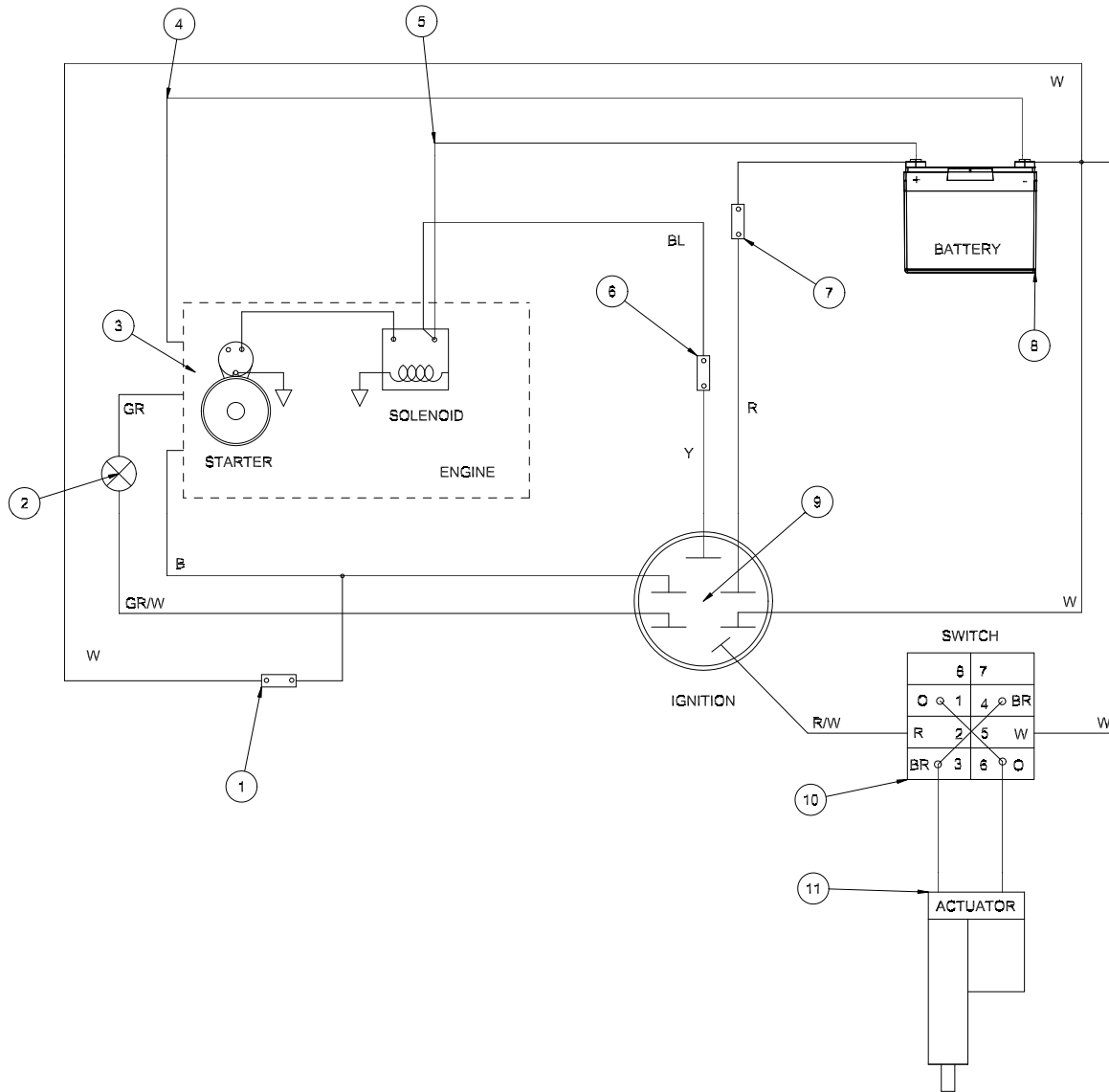

Color Code Chart	
Bl	Blue
Br	Brown
Y	Yellow
Grn	Green
O	Orange
R	Red
B	Black
P	Purple
W	White

WIRING PARTS LIST

REF #	PART #	DESCRIPTION	QUANTITY
1	14-272	Seat Switch	1
2	50-359	Warning Indicator Lights	1
3	41-082	10hp Briggs & Stratton	1
4	48-147	Negative Black Battery Cable	1
5	50-323	Positive Red Battery Cable	1
	45-416	Red Battery Boot	1
6		Neutral Switch on Trans axle	1
7	8975	Circuit Breaker, 30AMP	1
	8977	Breaker Boot	1
8		Battery (not included)	1
9	13-488	Ignition Switch	1
10	15-727	Switch Actuator, no light	1
	15-728	Centering Switch, On-Off-On	1
11	45-631	Actuator	1
	41-085	Wire Harness	1

MAIN FRAME DRAWING

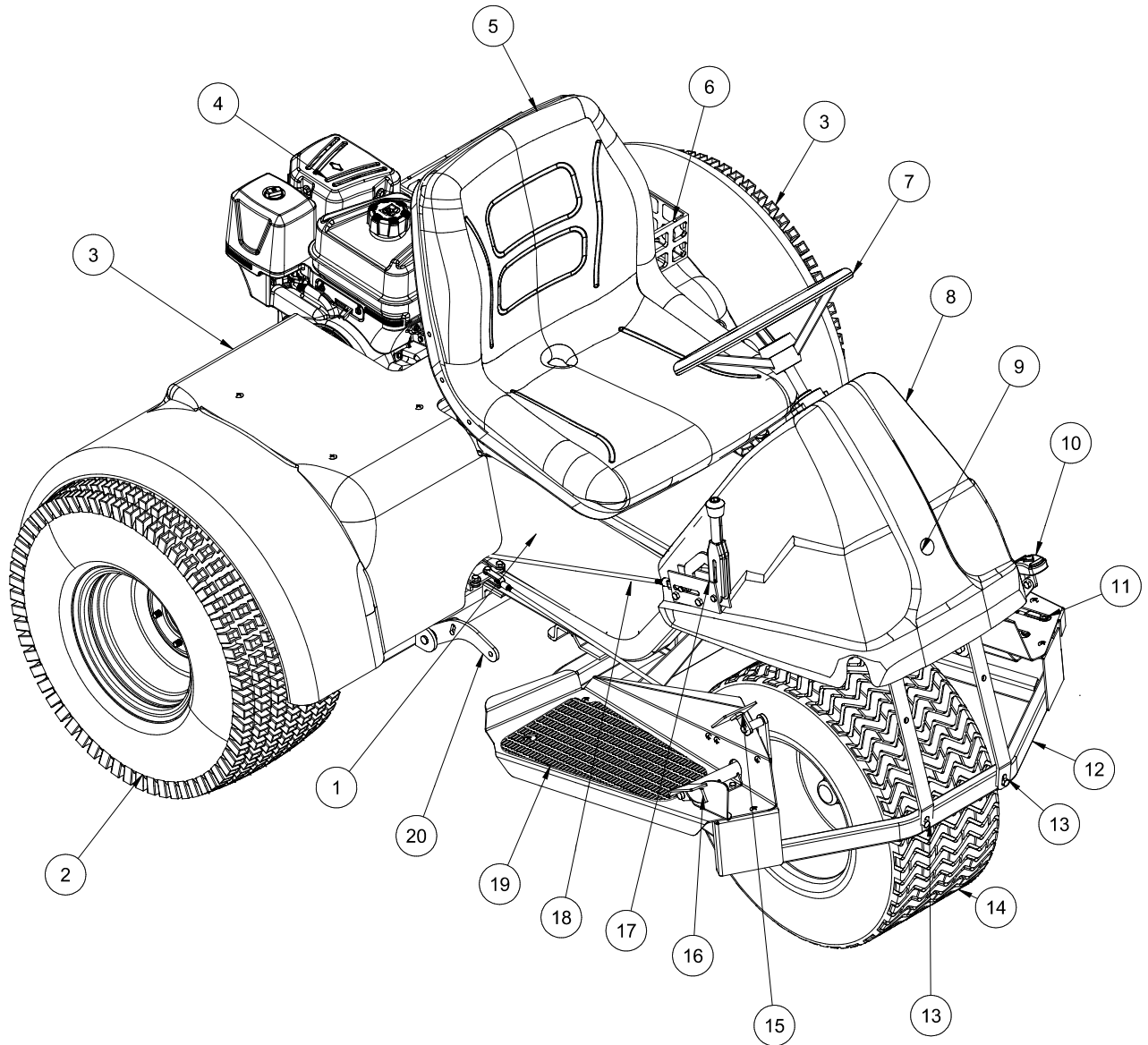

Parts

MAIN PARTS LIST

REF#	PART#	DESCRIPTION	QUANTITY
1	41-032	RH Side Panel	1
	41-033	LH Side Panel	1
2	45-617	Tire & Wheel	2
	45-617-01	Tire, 25 - 10.00 x 12	2
	45-617-02	Wheel	2
2	41-071	Rear Lift	1
3	41-081	RH Rear Fender (fiberglass)	1
	41-094	LH Rear Fender (fiberglass)	1
4	41-082	Engine, Briggs & Stratton 10HP	1
5	14-293	Low Back Seat Assembly	1
6	8-532	Crate	1
7	20-057	Steering Wheel	1
	20-129	Center Cap	1
8	45-026	Nose Cone (fiberglass)	1
9	18-436	Lock Hole Plug	1
10	41-029	Forward Pedal	1
	45-022	Molded Foot Pedal	1
11	41-034	LH Floorboard	1
	41-090	LH Floor Mat	1
12	41-050	Bumper	1
13	13-208	Bumper Brace	2
14	52-120	Tire and Wheel	1
	52-120-01	Tire, 20 -10.00 x 10	1
	16-857-02	Wheel	1
15	41-053	Brake Pedal	1
	41-077	Brake Pedal Pad	1
	15-015	Pedal Pad	1
16	41-049	Gas Pedal	1
17	60-106	Park Brake Lever	1
18	41-069	Foot Brake Link	1
19	41-035	RH Floorboard	1
	41-089	RH Floor Mat	1
20	41-065	Center Lift	1
	41-062	Lift Lock	1

DASH PANEL DRAWING

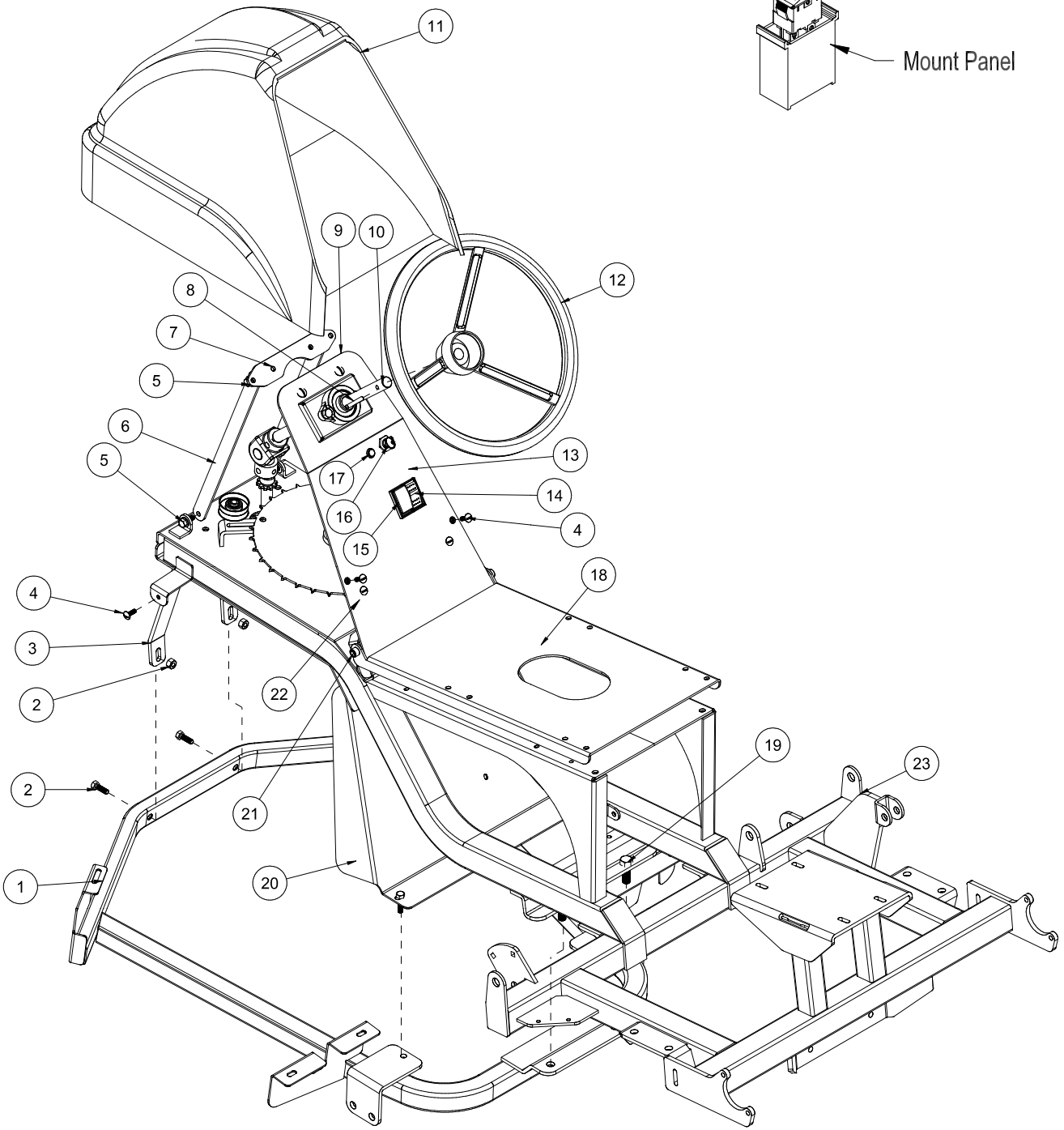
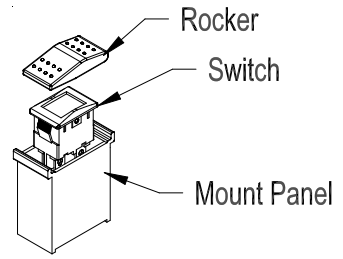

Parts

DASH PANEL PARTS LIST

REF#	PART#	DESCRIPTION	QUANTITY
1	41-050	Bumper	1
2	HB-38-16-200	Hex Bolt, $\frac{3}{8}$ -16 x 2	2
	HW-38	Flat Washer, $\frac{3}{8}$	2
	HNTL-38-16	Lock Nut, $\frac{3}{8}$ -16	2
3	13-208	Bumper Brace	2
	HB-38-16-300	Hex Bolt, $\frac{3}{8}$ -16 x 3	2
	HW-38	Flat Washer, $\frac{3}{8}$	2
	HNTL-38-16	Lock Nut, $\frac{3}{8}$ -16	2
4	HSTP-14-20-075	Truss Head Screw, $\frac{1}{4}$ -20 x $\frac{3}{4}$	8
	HNFL-14-20	Flange Whiz-loc Nut, $\frac{1}{4}$ -20	8
5	HBFL-516-18-075	Flange Whiz-loc Bolt, $\frac{5}{16}$ - 18 x $\frac{3}{4}$	4
	HNFL-516-18	Flange Whiz-loc Nut, $\frac{5}{16}$ -18	4
6	45-124	Dash Brace	2
7	45-078	Top Mount Bracket	1
8	HRP-14-150	Roll Pin, $\frac{1}{4}$ x $1\frac{1}{2}$	1
9	41-063	Dash Panel	1
10	41-075	Steering Shaft	1
11	45-026	Nose Cone - Fiberglass	1
12	20-057	Steering Wheel	1
	20-129	Center Cap	1
13	41-086	Decal, Switch Panel	1
14	15-727	Rocker, No light	1
	15-728	Centering Switch, On-Off-On	1
	15-725	Mount Panel End	1
15	15-730	Mount Panel Plug	1
	15-725	Mount Panel End	1
16	13-488	Ignition Switch	1
17	50-359	Warning Light	1
18	41-064	Seat Panel	1
19	HB-716-14-100	Hex Bolt, $\frac{7}{16}$ - 14 x 1	2
	HNTL-716-14	Lock Nut, $\frac{7}{16}$ - 14	2
20	41-036	Mud Guard	1
	HBFL-38-16-075	Flange Whiz-loc Bolt, $\frac{3}{8}$ -16 x $\frac{3}{4}$	2
	HNFL-38-16	Flange Whiz-loc Nut, $\frac{3}{8}$ -16	2
21	HBSH-38-38	Shoulder Bolt, $\frac{3}{8}$ -UNC x $\frac{3}{8}$	2
	HNSQ-516-18	Square Nut, $\frac{5}{16}$ -18	2
22	45-049	Wire Retainer	1
23	41-025	Mainframe	1

FRONT FORK DRAWING

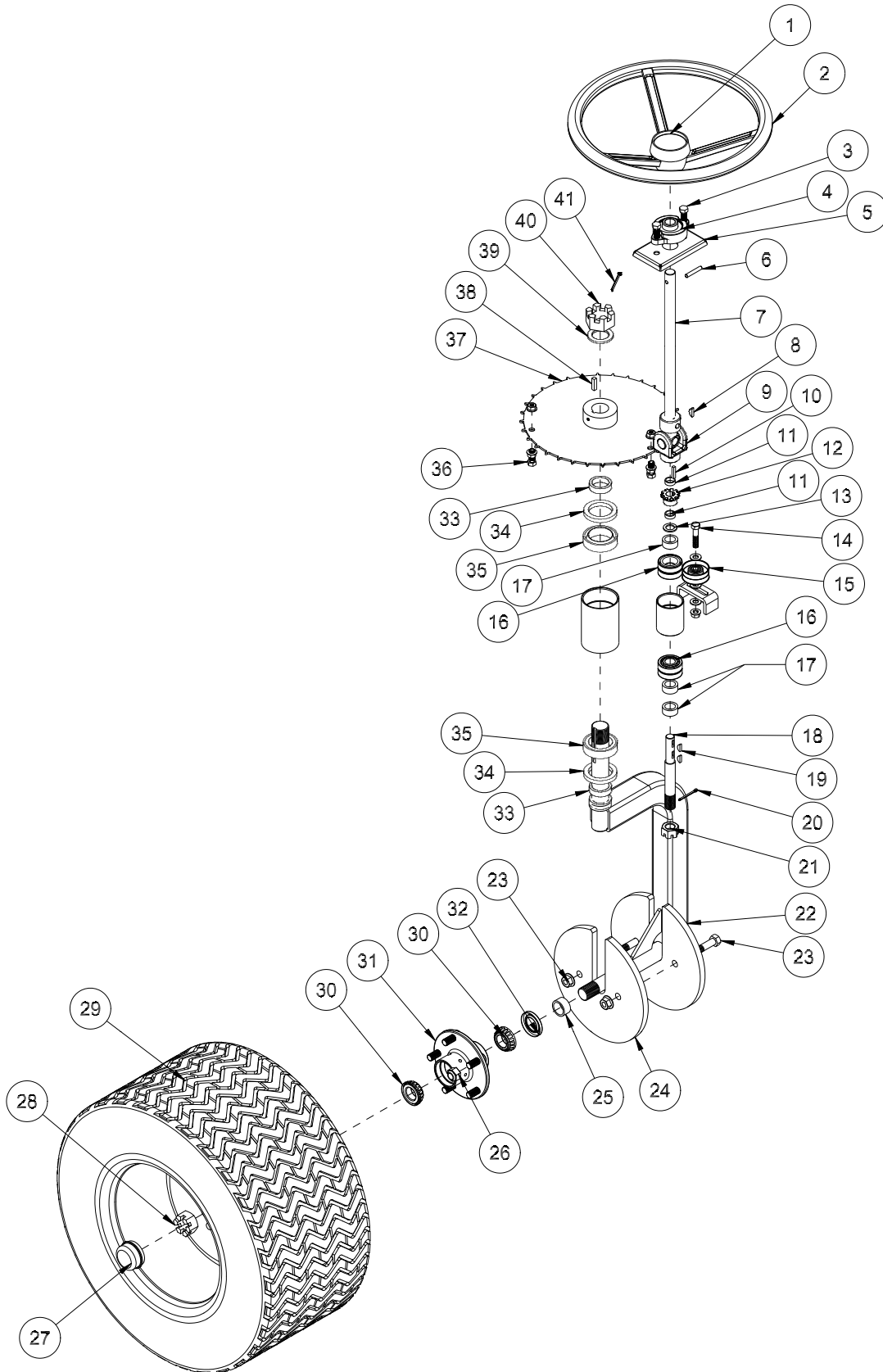

Parts

FRONT FORK PARTS LIST

REF#	PART#	DESCRIPTION	QUANTITY
1	20-129	Center Cap	1
2	20-057	Steering Wheel	1
3	HBFL-38-16-075	Flange Whiz-loc Bolt, $\frac{3}{8}$ -16 x $\frac{3}{4}$	2
	HNFL-38-16	Flange Whiz-loc Nut, $\frac{3}{8}$ - 16	2
4	40-009	Flange Block Bearing	1
5	41-078	Bearing Spacer Plate	1
6	HRP-14-150	Roll Pin, $\frac{1}{4}$ x $1\frac{1}{2}$	1
7	41-075	Steering Shaft	1
8	HWK-316-075	Woodruff Key, $\frac{3}{16}$ x $\frac{3}{4}$	1
9	60-300	U-joint	1
10	HKSQ-316-100	Square Key, $\frac{3}{16}$ x 1	1
11	60-325	Spacer	2
12	60-298	Sprocket	1
13	HMB-58-14	Machine Bushing, $\frac{5}{8}$ x 14GA	1
14	HB-38-16-175	Hex Bolt, $\frac{3}{8}$ -16 x $1\frac{3}{4}$	1
	HW-38	Flat Washer, $\frac{3}{8}$	2
	HNTL-38-16	Lock Nut, $\frac{3}{8}$ -16	1
15	26-060	Idler Pulley	1
16	11-038	Bearing w/ Race	2
	11-039	Oil Seal	2
17	11-040	Spacer, $\frac{1}{2}$ "	3
18	13-005	Bottom Steering Shaft	1
19	HWK-316-063	Woodruff Key, $\frac{3}{16}$ x $\frac{5}{8}$	2
20	HP-18-150	Cotter Pin, $\frac{1}{8}$ x $1\frac{1}{2}$	1
21	HNA-34-16	Axle Nut, $\frac{3}{4}$ -16	1
22	41-072	Front Fork	1
23	HB-12-13-250	Hex Bolt, $\frac{1}{2}$ -13 x $2\frac{1}{2}$	2
	HNTL-12-13	Lock Nut, $\frac{1}{2}$ - 13	2
24	42-826	Weight, Front Fork	1
25	11-042	Spacer, $\frac{5}{8}$ "	1
26*	HNL-12-20	Lug Nut, $\frac{1}{2}$ -20	5
27*	80-167	Dust Cap	1
28	HNAR-100-14	Slotted Jam Nut, 1 x 14	1
	HP-18-150	Cotter Pin, $\frac{1}{8}$ x $1\frac{1}{2}$	1
29	52-120	Tire and Wheel	1
	52-120-01	Tire, 20 -10.00 x 10	1
	16-857-02	Wheel	1
30*	11-043	Bearing w/ races	2
	11-043-01	Bearing	2
	11-043-02	Race	2
31*	80-019	Hub, Complete (includes* items)	1
	27-022-02	Stud, $\frac{1}{2}$ - 20 $1\frac{7}{16}$	5
32*	11-041	Oil Seal, 1"	1
33	20-141	Spacer	2
34	20-142	Oil Seal, $1\frac{1}{8}$ "	2
35	20-143	Bearing w/ Race	2
36	HB-38-16-175	Hex Bolt, $\frac{3}{8}$ -16 x $1\frac{3}{4}$	2
	HNFL-38-16	Flange Whiz-loc Nut, $\frac{3}{8}$ -16	4
37	41-055	Steering Sprocket	1
38	HKSQ-14-100	Square Key, $\frac{1}{4}$ x 1	1
39	HMB-114-10	Machine Bushing, $1\frac{1}{4}$ x 10GA	1
40	HNA-114-12	Axle Nut, $1\frac{1}{4}$ -12	1
41	HP-18-200	Cotter pin, $\frac{1}{8}$ x 2	1
NS	8834-34	Roller Chain, #35	1
	18-114	Connector Link, #35	1
	18-143	Offset Link	1

SEAT PANEL DRAWING

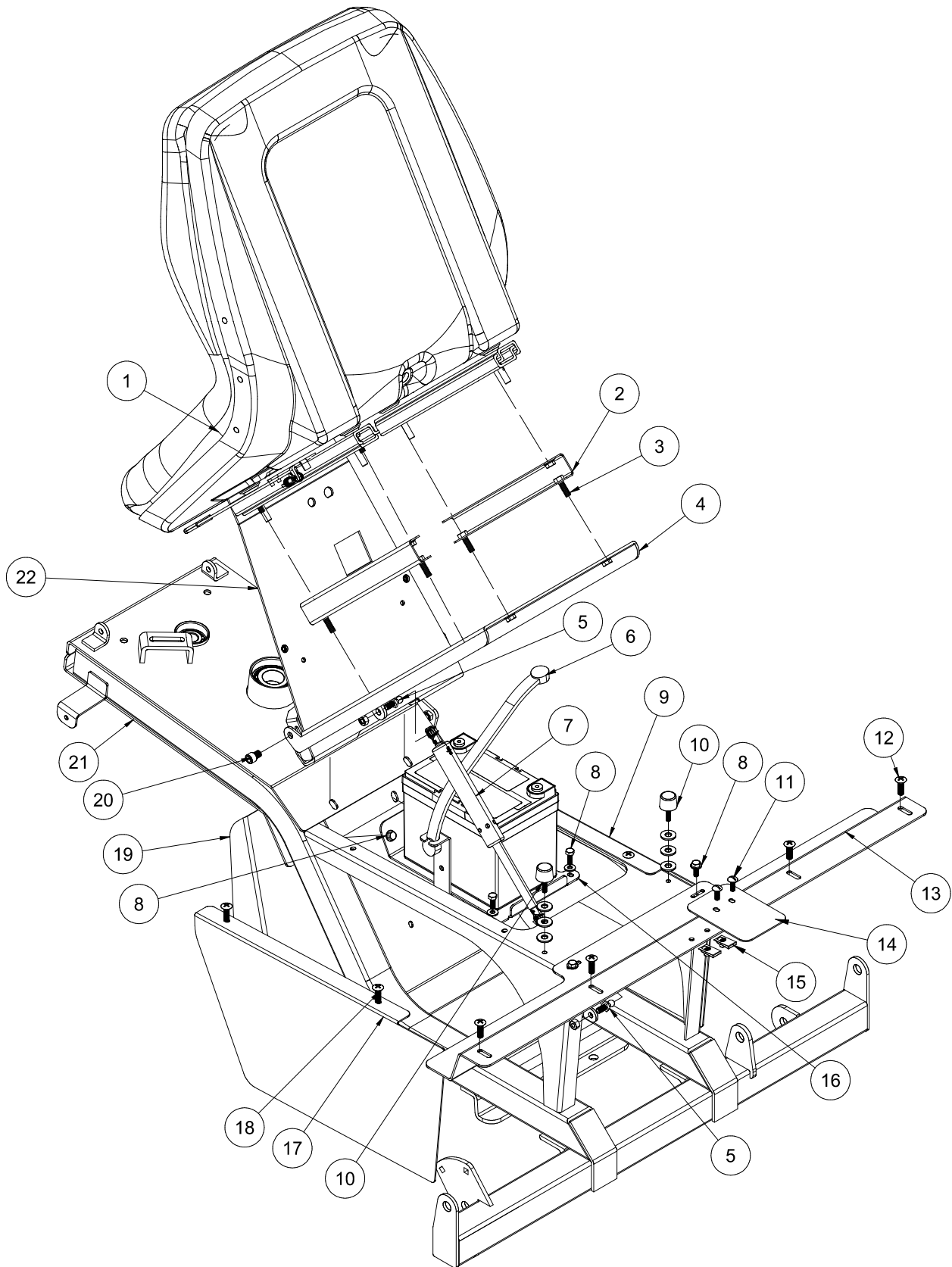

Parts

SEAT PANEL PARTS LIST

REF#	PART#	DESCRIPTION	QUANTITY
1	14-293	Low Back Seat Assembly	1
	HNFL-516-18	Flange Whiz-loc Nut, $\frac{5}{16}$ -18	4
	14-292	Seat Switch(included with seat)	1
2	41-041	Seat Riser	2
3	HB-516-18-075	Hex Bolt, $\frac{5}{16}$ -18 x $\frac{3}{4}$	4
	HNFL-516-18	Flange Whiz-loc Nut, $\frac{5}{16}$ -18	4
4	41-064	Seat Panel	1
5	26-034	Ball Stud	2
	HNFL-516-18	Flange Whiz-loc Nut, $\frac{5}{16}$ -18	2
6	8-603	Battery Strap	1
7	13-569	Gas Spring	1
8	HB-14-20-075	Hex Bolt, $\frac{1}{4}$ - 20 x $\frac{3}{4}$	6
	HW-14	Flat Washer, $\frac{1}{4}$	6
	HNFL-14-20	Flange Whiz-loc Nut, $\frac{1}{4}$ - 20	6
9	41-032	RH Side Panel	1
10	15-013	Rubber Bumper	2
	HNTL-14-20	Lock Nut, $\frac{1}{4}$ - 20	2
11	HSTP-14-28-075	Truss Head Screw, $\frac{1}{4}$ - 20 x $\frac{3}{4}$	2
12	HSTP-516-18-100	Truss Head Screw, $\frac{5}{16}$ - 18 x 1	4
	HNFL-516-18	Flange Whiz-loc Nut, $\frac{5}{16}$ - 18	4
13	41-046	Front Fender Mount	1
14	41-095	Fender Cover	1
15	HNEU-14-20	Extruded U Nut, $\frac{1}{4}$ -20	2
16	41-048	Battery Tray	1
17	41-033	LH Side Panel	1
18	HSTP-14-20-075	Truss Head Screw, $\frac{1}{4}$ -20 x $\frac{3}{4}$	4
	HNFL-14-20	Flange Whiz-loc Nut, $\frac{1}{4}$ -20	4
19	41-036	Mud Guard	1
20	HBSH-38-38	Shoulder Bolt, $\frac{3}{8}$ - UNC x $\frac{3}{8}$	2
	HNSQ-516-18	Square Nut, $\frac{5}{16}$ -18	2
21	41-025	Main Frame	1
22	41-063	Dash Panel	1

FOOT PEDAL LINKAGE DRAWING

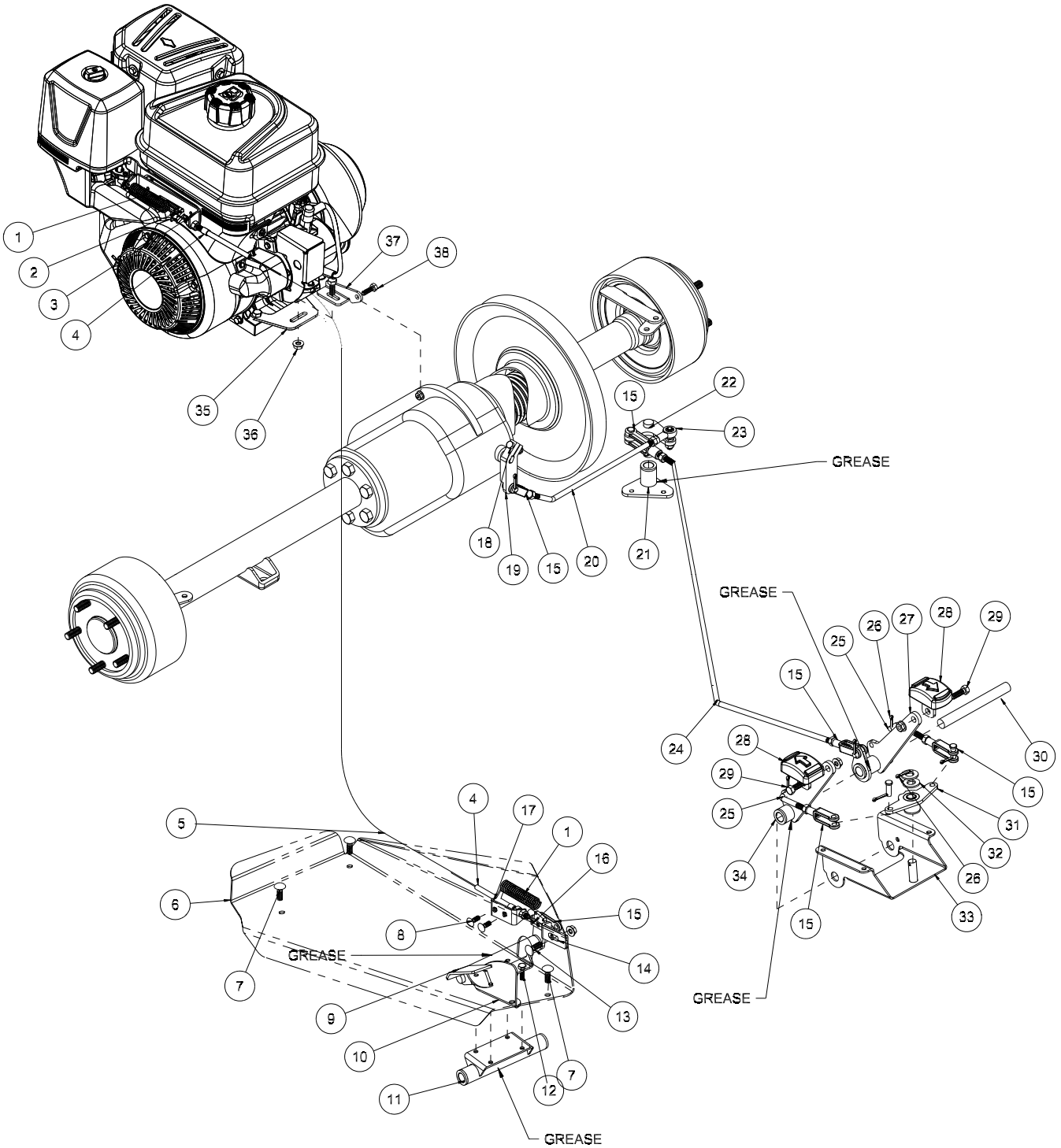

Parts

FOOT PEDAL LINKAGE PARTS LIST

REF#	PART#	DESCRIPTION	QUANTITY
1	16-046	Extension Spring	2
2	21-161	Wire Block	1
3	41-045	Throttle Cable Mount	1
4	17-155	Retainer	1
5	17-151	Cable	1
	17-152	Conduit	1
6	41-035	RH Floorboard	1
7	HSTP-516-18-100	Truss Head Screw, $\frac{5}{16}$ -18 x 1	6
	HW-316	Flat Washer, $\frac{5}{16}$	6
	HNTL-516-18	Lock Nut, $\frac{5}{16}$ -18	6
8	HSTP-14-20-075	Truss Head Screw, $\frac{1}{4}$ -20 x $\frac{3}{4}$	2
	HNFL-14-20	Flange Whiz-loc Nut, $\frac{1}{4}$ -20	2
9	41-049	Gas Pedal	1
	76-128	Flange Bushing	2
10	41-079	Throttle Foot Rest	1
11	41-054	Brake Pedal Mount	1
	76-128	Flange Bushing	2
12	HB-14-20-100	Hex Bolt, $\frac{1}{4}$ -20 x 1	4
	HNTL-14-20	Lock Nut, $\frac{1}{4}$ -20	4
13	HSTP-516-18-075	Truss Head Screw, $\frac{5}{16}$ -18 x $\frac{3}{4}$	1
	HNFL-516-18	Flange Whiz-loc Nut, $\frac{5}{16}$ -18	1
14	41-044	Throttle Stop	1
15	11-100	Linkage yoke	6
	HN-516-24	Hex Nut, $\frac{5}{16}$ - 24	6
	HCP-516-100	Clevis Pin, $\frac{5}{16}$ x 1	6
	HP-18-075	Cotter Pin, $\frac{1}{8}$ x $\frac{3}{4}$	6
16	17-153	Clevis	1
	HCP-516-100	Clevis Pin, $\frac{5}{16}$ x 1	1
	HP-18-100	Cotter Pin, $\frac{1}{8}$ x 1	1
17	41-037	Throttle Cable Bracket	1
18	HB-14-20-100	Hex Bolt, $\frac{1}{4}$ - 20 x 1	1
	HNTL-14-20	Lock Nut, $\frac{1}{4}$ - 20	1
19	52-106	Shaft Input Adapter	1
20	41-067	Short Shift Link	1
21	41-051	Shift Relay	1
	76-128	Flange Bushing	2
	HB-14-20-100	Hex Bolt, $\frac{1}{4}$ - 20 x 1	2
	HNTL-14-20	Lock Nut, $\frac{1}{4}$ - 20	2

FOOT PEDAL LINKAGE DRAWING

Parts

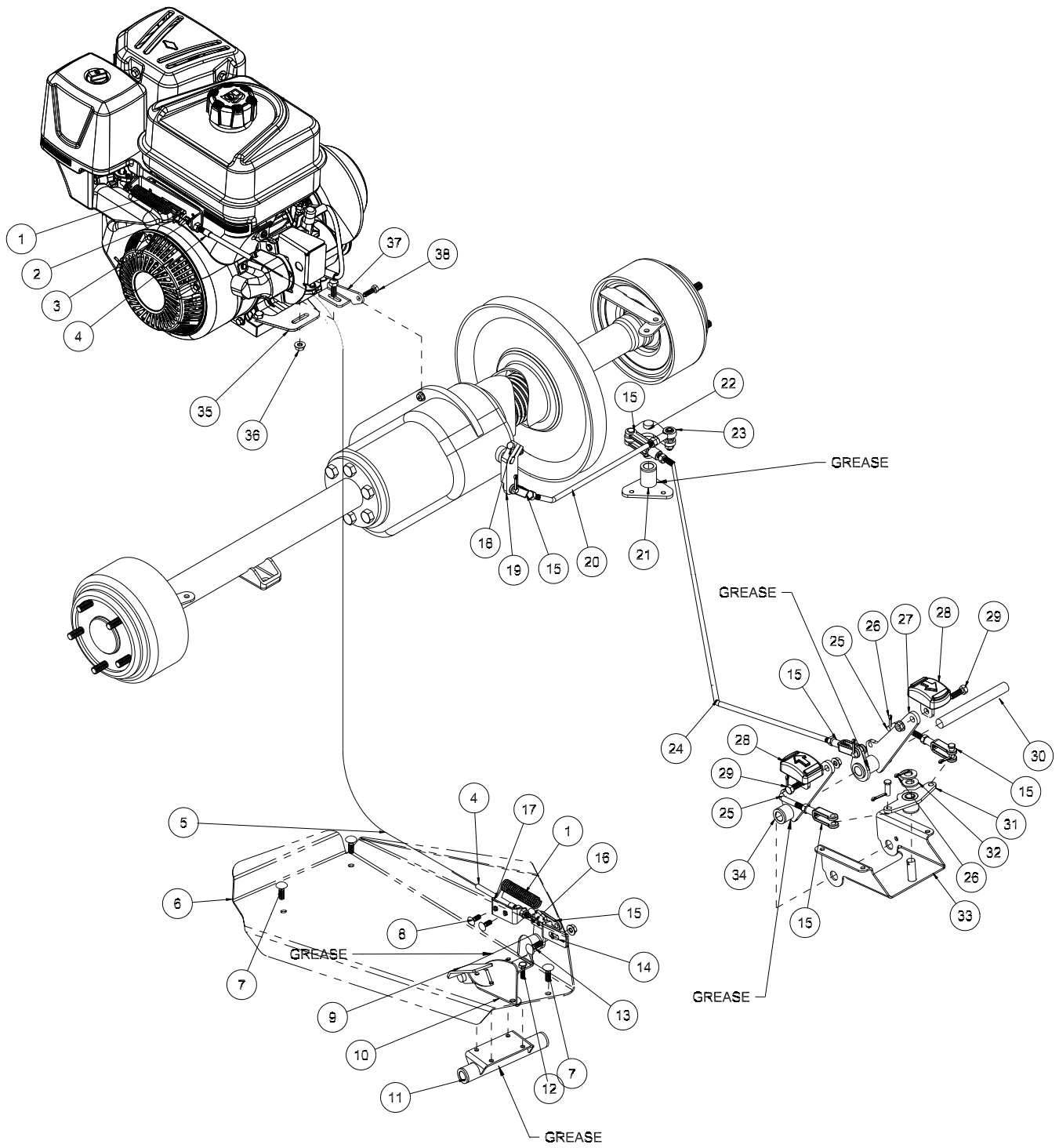

FOOT PEDAL LINKAGE PARTS LIST

REF#	PART#	DESCRIPTION	QUANTITY
22	41-052	Shift Relay Link	1
23	18-441	Ball Joint	1
	HWL-516	Lock Washer, $\frac{5}{16}$	1
	HN-516-24	Hex Nut, $\frac{5}{16}$ -24	2
24	41-068	Long Shift Link	1
25	41-076	Pedal Link	2
26	HP-18-100	Cotter Pin, $\frac{1}{8}$ x 1	3
27	41-029	Forward Pedal	1
	76-128	Flange Bushing	2
28	45-022	Molded Foot Pedal	2
29	HBFL-38-16-075	Flange Whiz-Loc Bolt, $\frac{3}{8}$ -16 x $\frac{3}{4}$	2
	HNFL-38-16	Flange Whiz-loc Nut, $\frac{3}{8}$ -16	2
30	41-026	Pedal Pivot Shaft	1
31	41-028	Pedal Relay	1
	18-043	Flange Bushing	1
32	HMB-12-14	Machine Bushing, $\frac{1}{2}$ x 14GA	2
33	41-031	Pedal Relay Mount	1
	HSTP-14-20-100	Truss Head Screw, $\frac{1}{4}$ - 20 x 1	4
	HNFL-14-20	Flange Whiz-loc Nut, $\frac{1}{4}$ - 20	4
34	41-030	Reverse Pedal	1
	76-128	Flange Bushing	1
35	41-039	Engine Brace	1
36	HB-516-18-125	Hex Bolt, $\frac{5}{16}$ -18 x $1\frac{1}{4}$	2
	HNFL-516-18	Flange Whiz-loc Nut, $\frac{5}{16}$ -18	2
37	41-038	Transmission Brace	1
38	HB-14-20-100	Hex Bolt, $\frac{1}{4}$ - 20 x 1	1
	HNFL-14-20	Flange Whiz-loc Nut, $\frac{1}{4}$ -20	1

BRAKE LINKAGE DRAWING

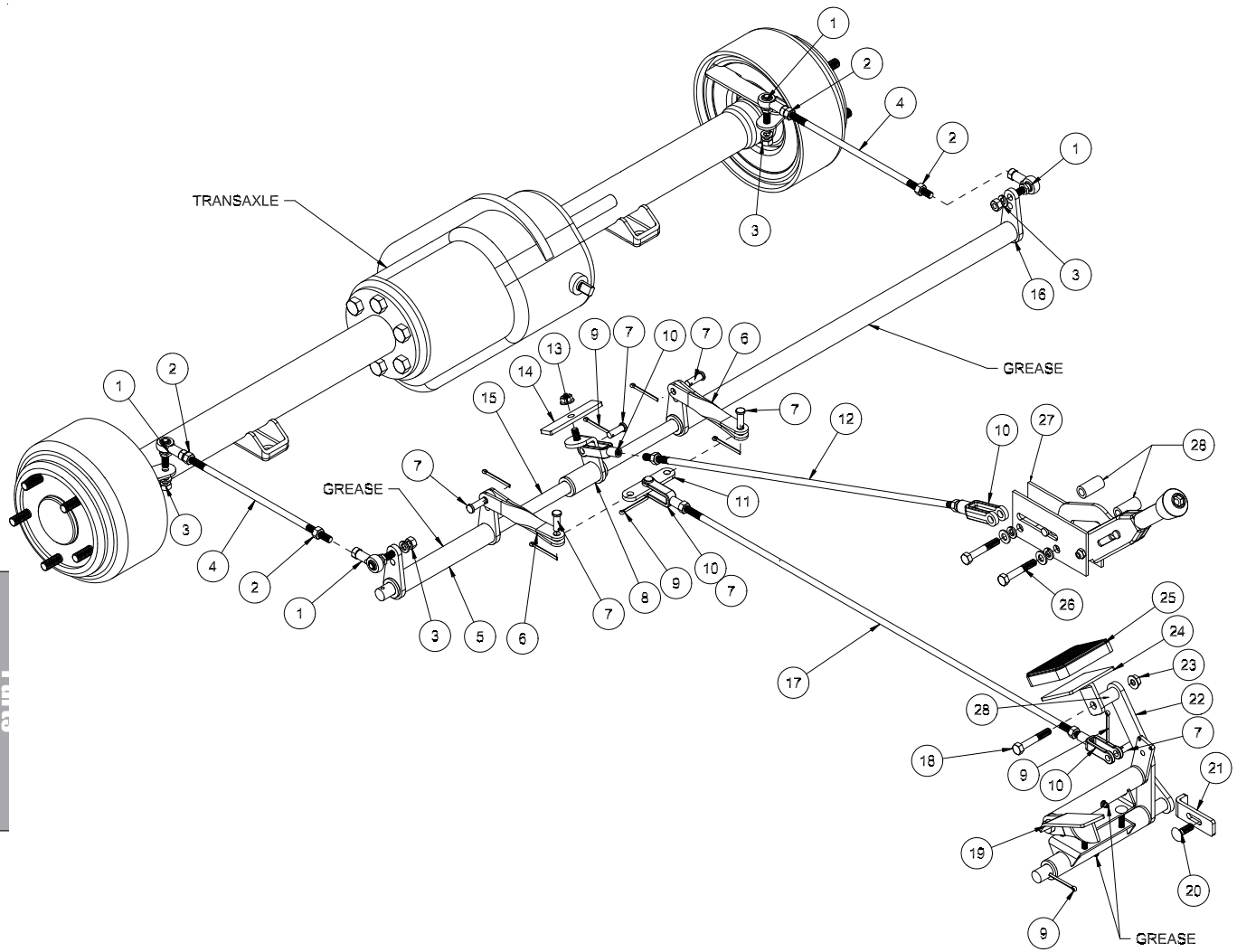

TRUCK

BRAKE LINKAGE PARTS LIST

REF#	PART#	DESCRIPTION	QUANTITY
1	18-441	Ball Joint	4
2	HN-516-24	Hex Nut, $\frac{5}{16}$ -24	4
3	HWL-516	Lock Washer, $\frac{5}{16}$	4
4	41-088	Brake Rod	2
5	41-057	Right Hand Brake Relay	1
	76-128	Flange Bushing	2
6	41-061	Brake Link	4
7	HCP-516-100	Clevis Pin, $\frac{5}{16}$ x 1	8
8	41-056	Park Brake Lever	1
	76-128	Flange Bushing	2
9	HP-18-075	Cotter Pin, $\frac{1}{8}$ x $\frac{3}{4}$	8
10	11-100	Linkage Yoke	4
	HN-516-24	Hex Nut, $\frac{5}{16}$ -24	4
11	45-075	Equalizer Link	1
12	41-069	Foot Brake Link	1
13	HB-516-18-100	Hex Bolt. $\frac{5}{16}$ -18 x 1	1
	HNTL-516-18	Lock Nut, $\frac{5}{16}$ -18	1
14	41-047	Equalizer Link	1
15	41-059	Relay Shaft	1
16	41-058	LH Brake Relay	1
	76-128	Flange Bushing	2
17	41-070	Foot Brake Link	1
18	HB-38-16-200	Hex Bolt, $\frac{3}{8}$ -16 x 2	1
19	41-049	Gas Pedal	1
	76-128	Flange Bushing	2
20	HSTP-516-18-075	Truss Head Screw, $\frac{5}{16}$ -18 x $\frac{3}{4}$	1
	HNFL-516-18	Flange Whiz-loc Nut, $\frac{5}{16}$ -18	1
21	41-044	Throttle Stop	1
22	41-053	Brake Pedal	1
23	HNFL-38-16	Flange Whiz-loc Nut, $\frac{3}{8}$ -16	1
24	41-077	Brake Pedal Pad	1
25	15-015	Pedal Pad	1
26	HB-14-20-275	Hex Bolt, $\frac{1}{4}$ -20 x $2\frac{3}{4}$	2
	HWL-14-20	Lock Washer, $\frac{1}{4}$ -20	4
	HNTL-14-20	Lock Nut, $\frac{1}{4}$ -20	2
27	60-106	Brake Lever	1
28	41-060	Spacer	3

REAR AXLE & ENGINE DRAWING

Parts

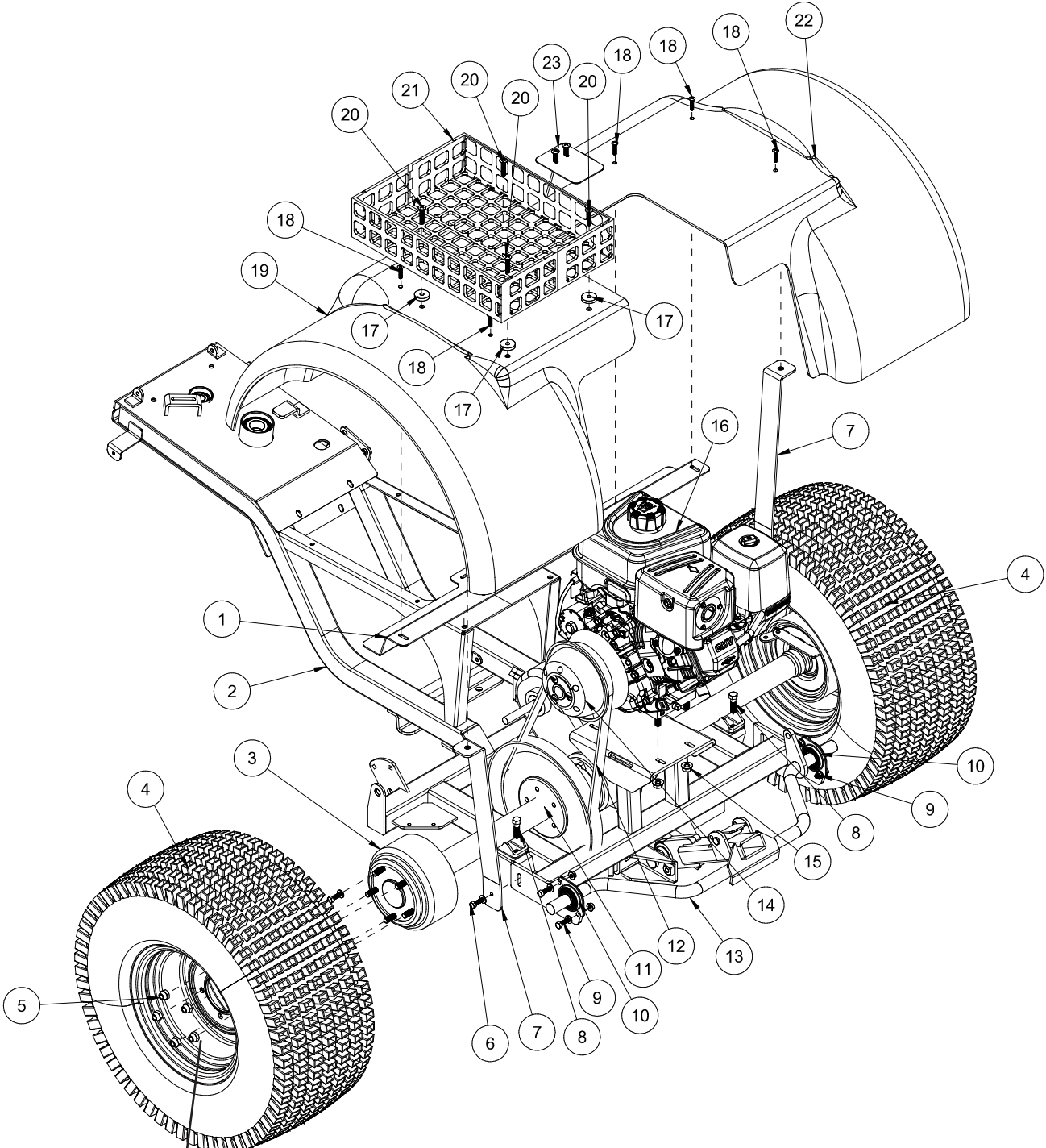

Torque To
120 ft/lbs(156Nm)

REAR AXLE & ENGINE PARTS LIST

REF#	PART#	DESCRIPTION	QUANTITY
1	41-046	Front Fender Mount	1
2	41-025	Main Frame	1
3	41-080	Trans axle	1
4	45-617	Tire & Wheel	2
	45-617-01	Tire, 25 - 10.00 x 12	2
	45-617-02	Wheel	2
5	HNL-12-20	Lug Nut, 1/2 - 20	10
6	HB-516-18-100	Hex Bolt, 5/16 -18 x 1	2
	HW-516	Flat Washer, 5/16	2
	HNTL-516-18	Lock Nut, 5/16 - 18	2
7	41-042	Fender Brace	2
8	HB-716-14-100	Hex Bolt, 7/16 - 14 x 1	4
	HW-716	Flat Washer, 7/16	4
	HNTL-716-14	Lock Nut, 7/16 - 14	4
9	HBCL-516-18-075	Carriage Bolts, 5/16 -18 x 3/4	4
	HNFL-516-18	Flange Whiz-loc Nuts, 5/16 -18	4
10	13-391	Flange Bearing	2
11	41-083	Driven Converter	1
12	41-084	Drive Belt	1
13	41-096	Rear Lift Bar	1
14	52-044	Drive Converter	1
	HB-716-20-250	Hex Bolt, 7/16 - 2 1/2	1
	HW-716	Flat Washer, 7/16	1
	HWL-716	Lock Washer, 7/16	1
	HB-12-20-200	Hex Bolt, 1/2 - 20 x 2	1
	HW-12	Flat Washer, 1/2	1
	HWL-12	Lock Washer, 1/2	1
15	HNFL-516-18	Flange Whiz-loc Nut, 5/16 -18	4
	HB-516-18-125	Hex Bolt, 5/16 -18 x 1 1/4	4
16	41-082	Engine, Briggs & Stratton, 10HP	1
17	HSP-1260-340-250	Spacer	4
18	HSTP-516-18-100	Truss Head Screw, 5/16 -18 x 1	6
19	41-081	RH Rear fender (fiberglass)	1
20	HSTP-516-18-150	Truss Head Screw, 5/16 -18 x 1 1/2	4
	HNFL-516-18	Flange Whiz-loc Nut, 5/16 -18	4
21	8-532	Crate	1
22	41-094	LH Rear fender (fiberglass)	1
23	41-095	Fender Cover	1
	HSTP-14-20-075	Truss Head Screw, 1/4 - 20 x 3/4	2
	HNEU-14-20	Extruded U Nut, 1/4 - 20	2

CENTER LIFT DRAWING

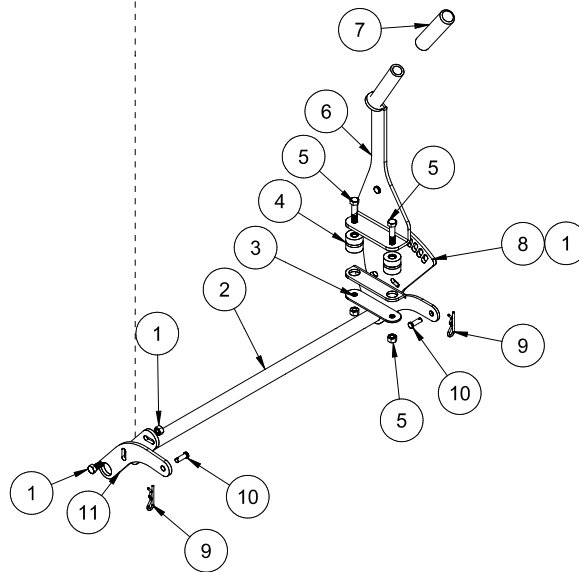
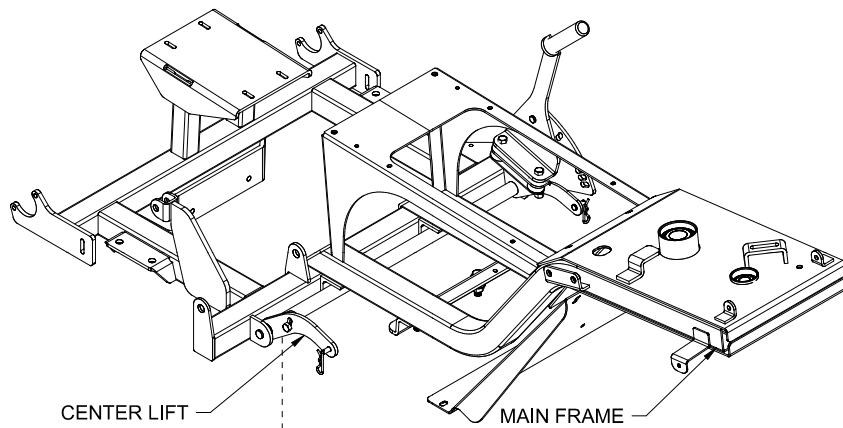

Parts

REF #	PART #	DESCRIPTION	QUANTITY
1	HBCL-516-18-100	Carriage Bolt, $\frac{5}{16}$ -18 x 1	3
	HNFL-516-18	Flange Whiz-loc Nut, $\frac{5}{16}$ -18	3
2	41-065	Center Lift	1
	76-128	Flange Bushing	2
3	41-027	Bushing Plate	1
4	52-124	Rubber Insulator	4
5	HB-38-16-225	Hex Bolt, $\frac{3}{8}$ -16 x 2 $\frac{1}{4}$	2
	HNTL-38-16	Lock Nut, $\frac{3}{8}$ -16	2
6	41-066	Center Lift Handle	1
7	15-019	Round Grip	1
8	41-062	Lift Lock	1
9	HHP-18	Bridge Pin, $\frac{1}{8}$ x 1	2
10	HCP-516-100	Clevis Pin, $\frac{5}{16}$ x 1	2
11	41-043	Mount Brace	1

REAR LIFT PARTS LIST

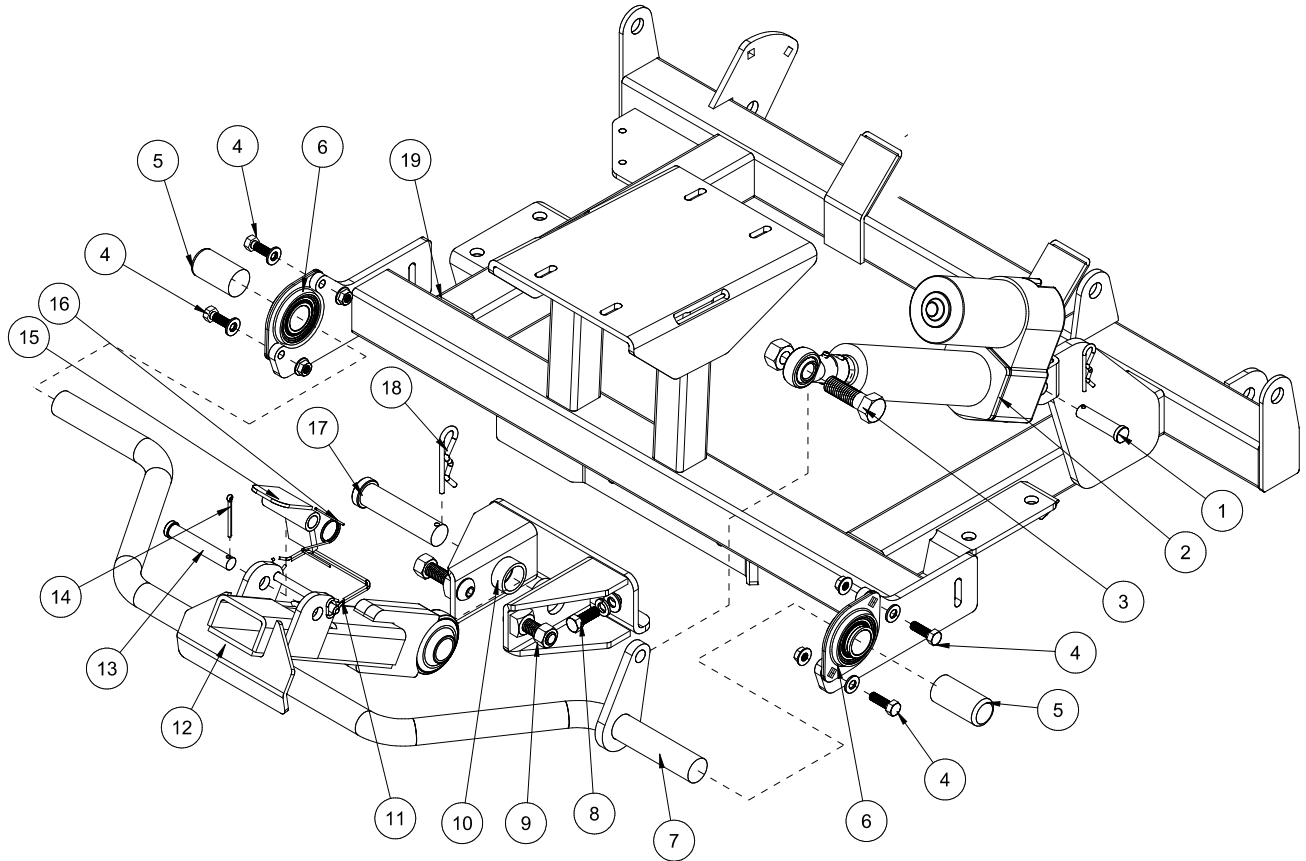

REF #	PART #	DESCRIPTION	QUANTITY
1	HCP-12-200	Clevis Pin, 1/2 x 2	1
	HHP-18	Bridge Pin, 1/8 x 1	1
2	45-631	4" Electric/Hydraulic Actuator	1
3	HB-716-14-100	Hex Bolt, 7/16 - 14 x 1	1
	HW-716	Flat Washer, 7/16	1
	HNTL-716-14	Lock Nut, 7/16 -14	1
4	HBCL-516-18-075	Carriage Bolts, 5/16 -18 x 3/4	4
	HNFL-516-18	Flange Whiz-loc Nuts, 5/16 -18	4
5	15-019	Round Grip	1
6	13-391	Flange Bearing	2
7	41-096	Rear Lift Bar	1
8	HB-38-24-100	Hex Bolt, 3/8 - 24 x 1	2
	HW-38	Flat Washer, 3/8	2
	HWL-38	Lock Washer, 3/8	2
9	HSSHB-12-13-200	Button Socket Head Cap Screw, 1/2-13 x 2	2
	HN-12-13	Hex Nut, 1/2-13	2
	HNCL-12-13	Center Lock Nut, 1/2-13	2
10	43-140	Frame Mount	1
11	25-382	Lock Pin	1
12	43-141	Lift Arm	1
13	HCP-12-350	Clevis Pin, 1/2 x 3 1/2	1
14	HP-18-100	Cotter Pin, 1/8 x 1	1
15	43-139	Lock	1
16	43-136	Torsion Spring	1
17	HCP-78-350	Clevis Pin, 7/8 x 3 1/2	1
18	HHP-.177	Bridge Pin, .177 x 3 3/4	1
19	41-025	Main Frame	1

41-020 LIGHT KIT

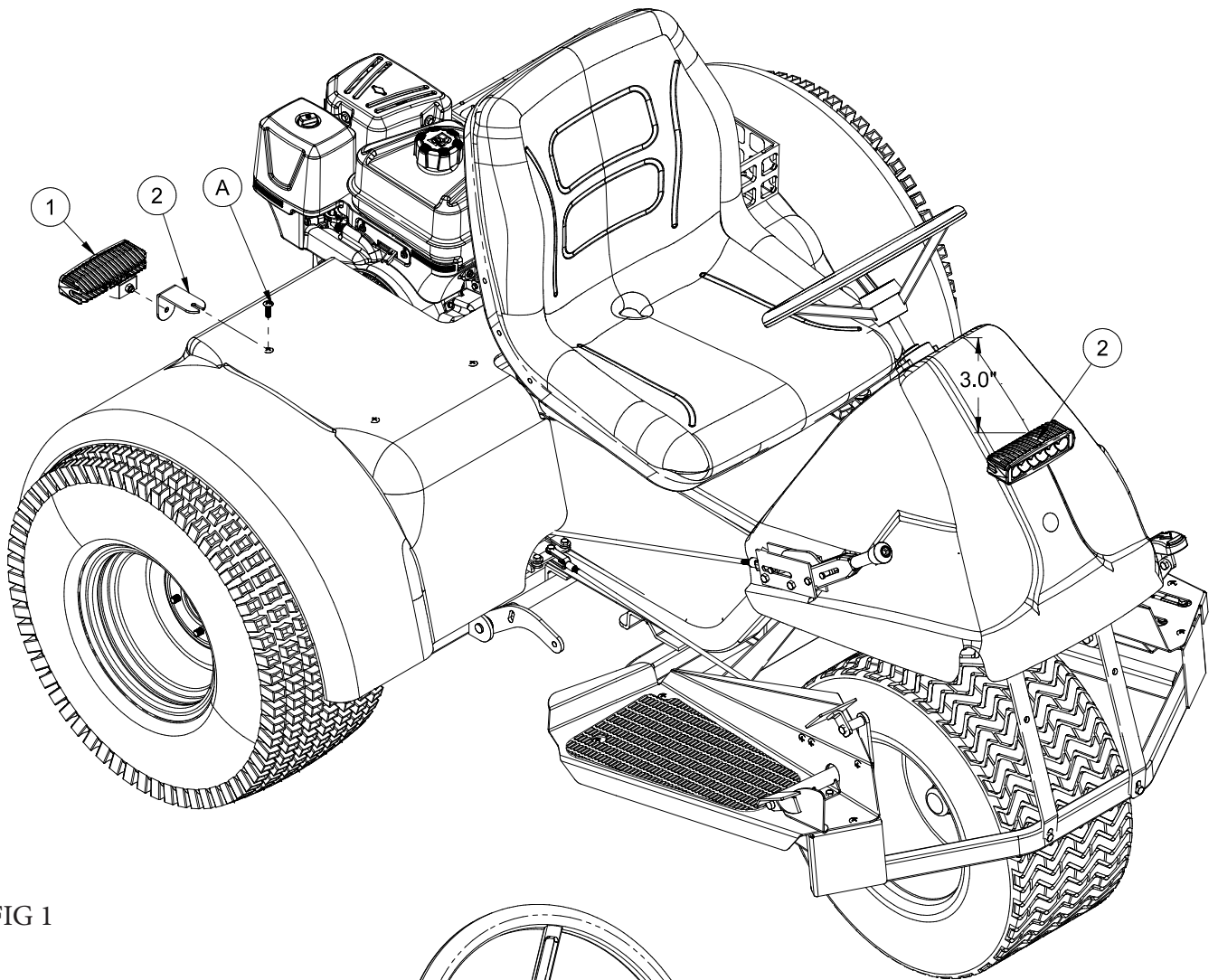
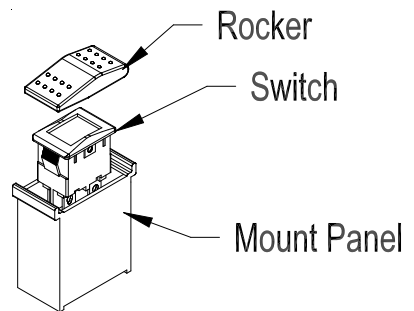
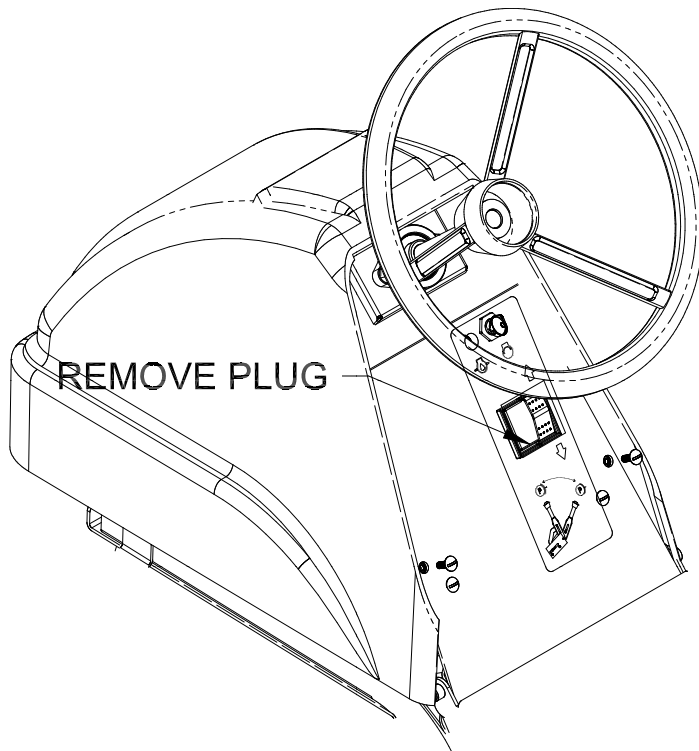

FIG 1



41-020 LIGHT KIT

REF#	PART#	DESCRIPTION	QUANTITY
1	10-732	LED Light with Connectors	2
	41-092	Wire Harness	1
2	41-093	Rear Light Bracket	1

INSTALLATION INSTRUCTIONS

1. Disconnect negative terminal from the battery.
2. Assemble light mounts to lights per manufacture instructions.
3. Remove nosecone. Measure down 3" from the top of the nosecone and to the center, drill a 5/16" hole. Measure down 1" below 5/16" hole and drill a 1/2" hole.
4. Using the 5/16" hole you just drilled, mount the headlight to the nose cone. Secure with light mount hardware. Feed wires through the 1/2" hole.
5. Remove blank switch cover on the dash panel(See Fig 1). Install switch with terminals on the bottom. Install the rocker cover on top of switch. Connect green white wire to lower terminal on switch.
6. Loosen right rear fender mount screw(Ref A) and slide slotted end of light mount bracket (Ref 2) under fender screw and then tighten screw.
7. Connect rear light wires to harness and feed harness under fender, through battery compartment to light switch. Attach rear light to rear mount bracket.
8. Connect black wire on ring to negative terminal on battery. Connect red wire on harness to light switch upper terminal.
9. Connect front light wires to harness and reinstall the nose cone to machine.
10. Reconnect battery negative cable.
11. Test light operation.

NOTE: Lights will only operate when the key is in the "On" position.

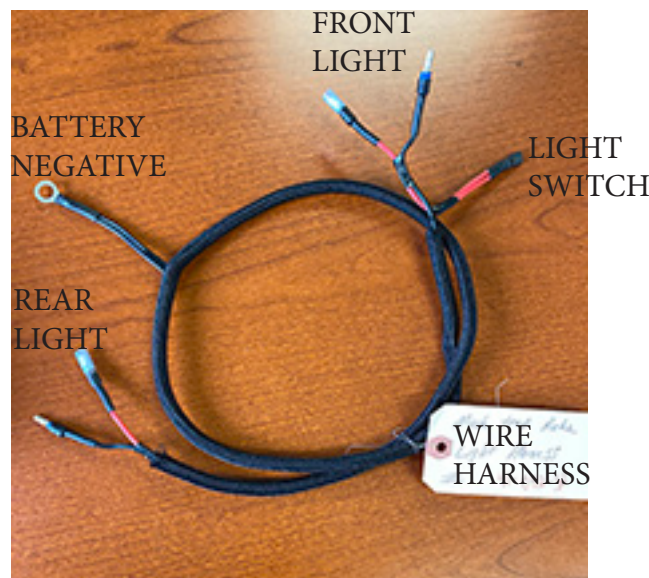

13-644 ALUMINUM PLOW

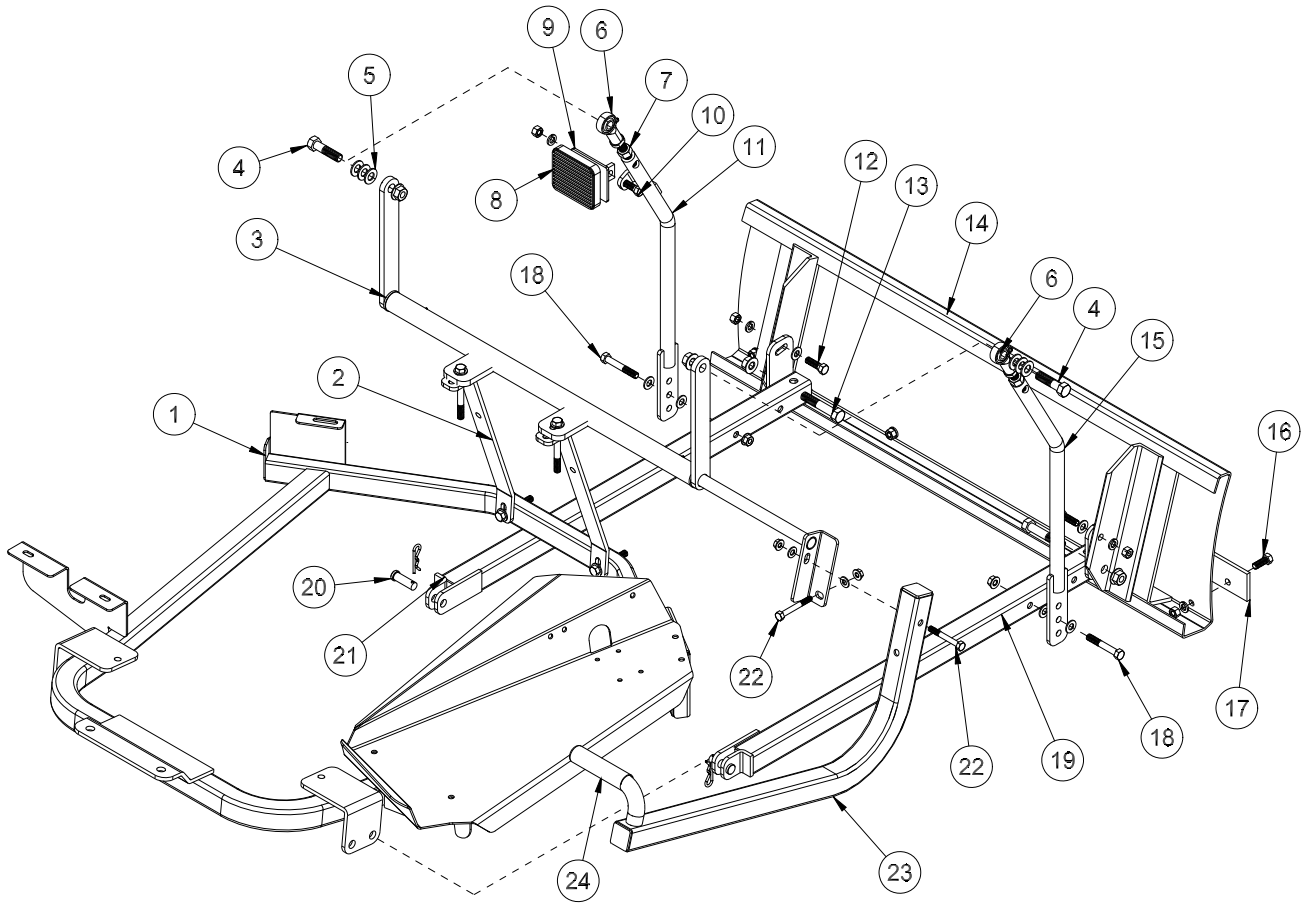

Accessories

13-644 SAND PLOW

REF#	PART#	DESCRIPTION	QUANTITY
1		Front Bumper	1
2	13-208	Bumper Brace	2
3	13-642	Lift Handle	1
4	HB-12-13-200	Hex Bolt, 1/2 - 13 x 2	2
	HNCL-12-13	Center Lock Nut, 1/2 - 13	2
5	HMB-12-14	Machine Bushing, 1/2 x 14GA	6
6	80-006	Rod End	2
7	HNJ-12-20	Jam Nut, 1/2 - 20	2
8	15-015	Pedal Pad	1
9	16-062	Pedal Pad Plate	1
10	HB-38-16-125	Hex Bolt, 3/8 - 16 x 1 1/4	1
	HWL-38	Lock Washer, 3/8	1
	HN-38-16	Hex Nut, 3/8 - 16	1
11	13-643	Left Lift Rod	1
12	HB-38-16-125	Hex Bolt, 3/8 - 16 x 1 1/4	2
	HW-38	Flat Washer, 3/8	2
	HNTL-38-16	Lock Nut, 3/8 - 16	2
13	HB-12-13-275	Hex Bolt, 1/2 - 13 x 2 3/4	2
	HNCL-12-13	Center Lock Nut, 1/2 - 13	2
14	27-017	Aluminum Sand Plow Blade(13-644-AB)	1
15	27-073	Right Lift Rod	1
16	HB-38-16 -100	Hex Bolt, 3/8 - 16 x 1	4
	HWL-38	Lock Washer, 3/8	4
	HN-38-16	Hex Nut, 3/8 - 16	4
17	13-167	Wear Blade	1
18	HB-38-16-250	Hex Bolt, 3/8 - 16 x 2 1/2	2
	HW-38	Flat Washer, 3/8	4
	HNTL-38-16	Lock Nut, 3/8 - 16	2
19	13-169	Right Pusher Bar	1
20	HCP-12-150	Clevis Pin	2
	HHP-18	Bridge Pin, 1/8	2
21	13-168	Left Pusher Bar	1
22	HB-516-18-225	Hex Bolt, 5/16 - 18 x 2 1/4	2
	HW-516	Flat Washer, 5/16	2
	HNTL-516-18	Lock Nut, 5/16 - 18	2
23	13-645	Handle	1
24	15-019	Hand Grip	1

INSTALLATION INSTRUCTIONS

1. Tine segments (Ref 1) should be bolted to the center lift bar (Ref 3). Use the 3/8 - 16 x 1 bolts, washers and lock nuts (Ref 2).
2. Attach lift links (Ref 7) to center lift bar (Ref 3) using 3/8 x 1 1/2 bolt and lock nut (Ref 4) provided.
3. Attach the assembled center lift bar to the front bumper using the clevis pin and bridge pin (Ref 8 & 6).
4. Using Center lift handle (Ref 9), lower center lift assembly to bottom slot on lift lock (Ref 10). Attach Lift Links (Ref 7) to the center lift (Ref 11) and the lift mount brace (Ref 12). secure with clevis and bridge pin (Ref 5 & 6)
5. This is a manual lift attachment. There is a pin that is welded to the lift handle (Ref 9). Flex handle inwards to remove pin from lift lock slot and lower center lift to next slot on lift lock (Ref 9). Continue lowering lift handle until you reach desired cultivating depth or the last slot on lift lock.



41-019 LEVELING BLADE DRAWING

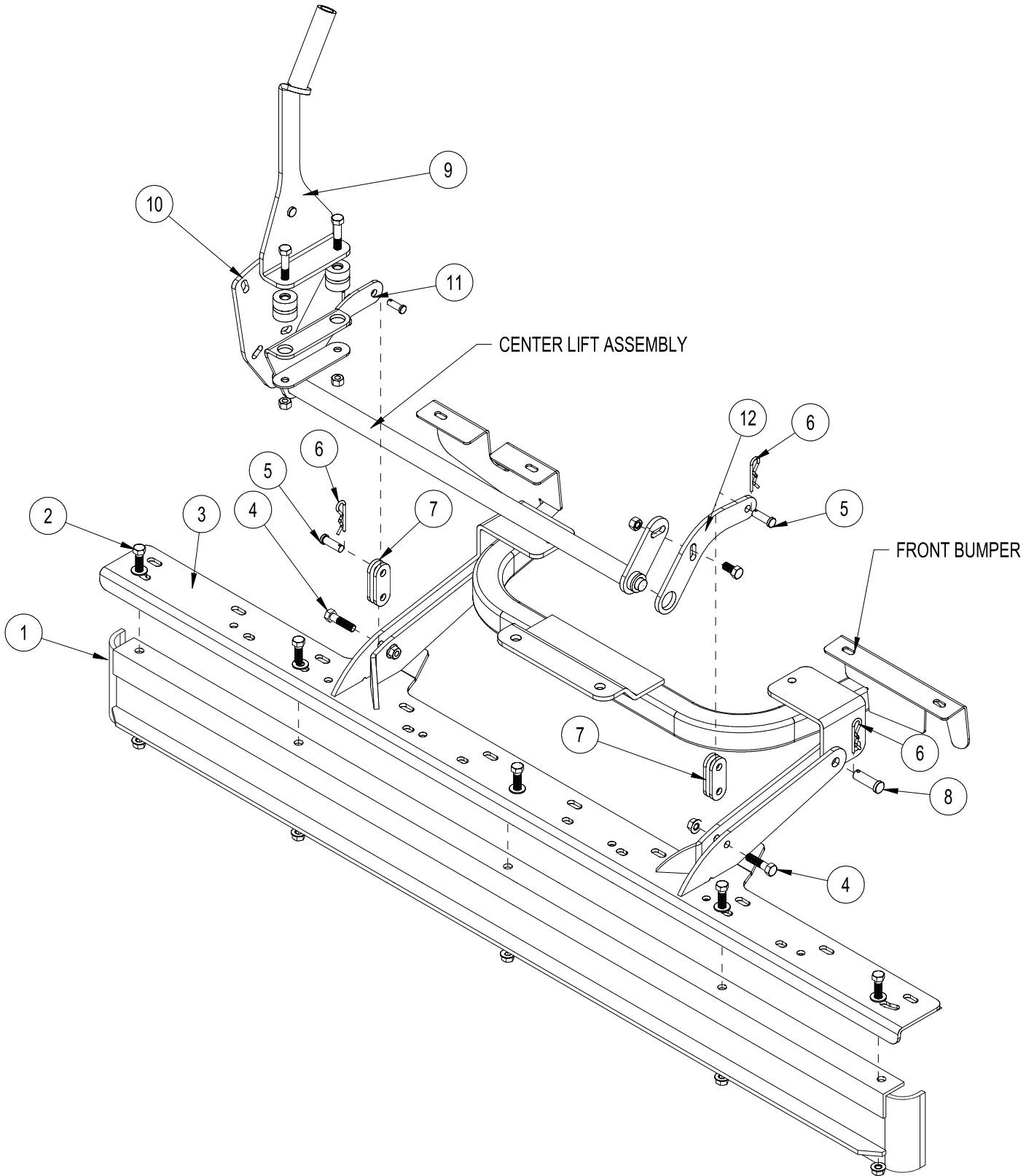

41-019 LEVELING BLADE PARTS LIST

REF#	PART#	DESCRIPTION	QTY
1	42-097	Leveling Blade	1
2	HB-38-16-100	Hex Bolt, $\frac{3}{8}$ - 16 x 1	5
	HNTL-38-16	Lock Nut, $\frac{3}{8}$ - 16	5
3	41-073	Center Lift Bar	1
4	HB-38-16-200	Hex Bolt, $\frac{3}{8}$ -16 x 2	2
	HNTL-38-16	Lock Nut, $\frac{3}{8}$ - 16	2
5	HCP-38-113	Clevis Pin, $\frac{3}{8}$ X $1\frac{1}{8}$	2
6	HHP-18	Bridge Pin, $\frac{1}{8}$	4
7	41-040	Lift Link	4
8	HCP-12-150	Clevis Pin, $\frac{1}{2}$ x $1\frac{1}{2}$	2
9*	41-066	Center Lift Handle	1
10*	41-062	Lift Lock	1
11*	41-065	Center Lift	1
12*	41-043	Lift Mount Brace	1

* Part of machine

INSTALLATION INSTRUCTIONS

1. Bolt leveling blade(Ref 1) to center lift bar (Ref 3) using five $\frac{3}{8}$ - 16 x 1 bolts and lock nuts(Ref 2), as shown on drawing.
2. Attach lift links (Ref 7) to center lift bar (Ref 3) using $\frac{3}{8}$ x 2 bolt and lock nut (Ref 4)provided.
3. Attach the assembled center lift bar to the front bumper using the clevis pin and bridge pin (Ref 8 & 6).
4. Using Center lift handle (Ref 9), lower center lift assembly to bottom slot on lift lock (Ref 10). Attach Lift Links (Ref 7) to the center lift (Ref 11) and the lift mount brace (Ref 12). secure with clevis and bridge pin (Ref 5 & 6)
5. This is a manual lift attachment. There is a pin that is welded to the lift handle (Ref 9). Flex handle inwards to remove pin from lift lock slot and lower center lift to next slot on lift lock (Ref 9). Continue lowering lift handle until you reach desired cultivating depth or the last slot on lift lock.
6. Test for proper operation.

NOTE: For a complete break down of the center lift assembly parts refer to the Rear and Center Lift drawing in the parts manual.

41-021 SAND CULTIVATOR DRAWING

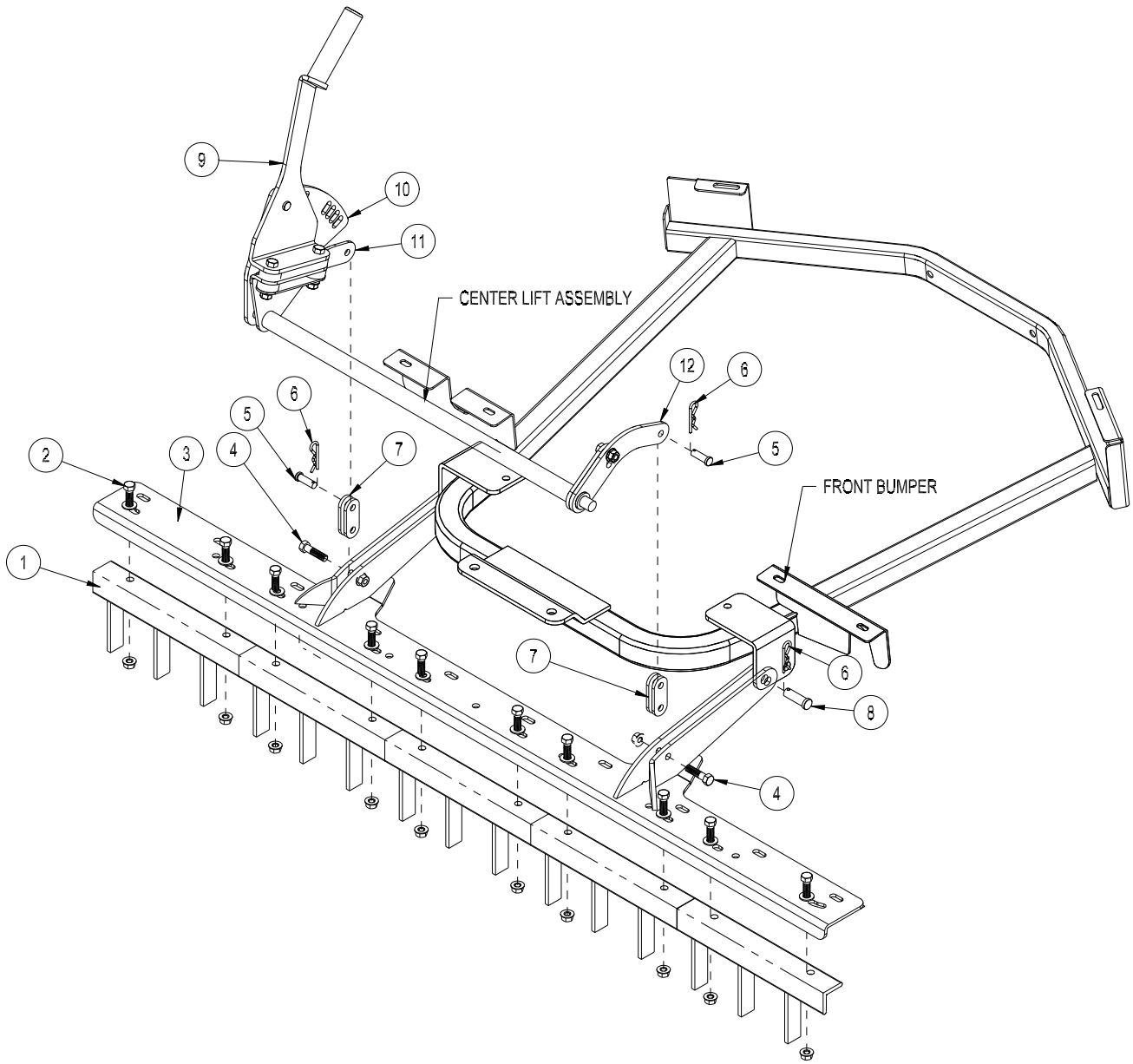

41-021 SAND CULTIVATOR PARTS LIST

REF#	PART#	DESCRIPTION	QTY
1	42-038	Tine Segment	5
2	HB-38-16-100	Hex Bolt, $\frac{3}{8}$ - 16 x 1	10
	HW-38	Flat Washer, $\frac{3}{8}$	10
	HNTL-38-16	Lock Nut, $\frac{3}{8}$ - 16	10
3	41-073	Center Lift Bar	1
4	HB-38-16-150	Hex Bolt, $\frac{3}{8}$ -16 x 1 $\frac{1}{2}$	2
	HNTL-38-16	Lock Nut, $\frac{3}{8}$ - 16	2
5	HCP-38-113	Clevis Pin, $\frac{3}{8}$ X 1 $\frac{1}{8}$	2
6	HHP-18	Bridge Pin, $\frac{1}{8}$	4
7	41-040	Lift Link	4
8	HCP-12-150	Clevis Pin, $\frac{1}{2}$ x 1 $\frac{1}{2}$	2
9*	41-066	Center Lift Handle	1
10*	41-062	Lift Lock	1
11*	41-065	Center Lift	1
12*	41-043	Lift Mount Brace	1

* Part of machine

INSTALLATION INSTRUCTIONS

1. Tine segments (Ref 1) should be bolted to the center lift bar (Ref 3). Use the $\frac{3}{8}$ - 16 x 1 bolts, washers and lock nuts (Ref 2).
2. Attach lift links (Ref 7) to center lift bar (Ref 3) using $\frac{3}{8}$ x 1 $\frac{1}{2}$ bolt and lock nut (Ref 4) provided.
3. Attach the assembled center lift bar to the front bumper using the clevis pin and bridge pin (Ref 8 & 6).
4. Using Center lift handle (Ref 9), lower center lift assembly to bottom slot on lift lock (Ref 10). Attach Lift Links (Ref 7) to the center lift (Ref 11) and the lift mount brace (Ref 12). secure with clevis and bridge pin (Ref 5 & 6)
5. This is a manual lift attachment. There is a pin that is welded to the lift handle (Ref 9). Flex handle inwards to remove pin from lift lock slot and lower center lift to next slot on lift lock (Ref 9). Continue lowering lift handle until you reach desired cultivating depth or the last slot on lift lock.
6. Test for proper operation.

NOTE: For a complete break down of the center lift assembly parts refer to the Rear and Center Lift drawing in the parts manual.

41-022 SAND CULTIVATOR DRAWING

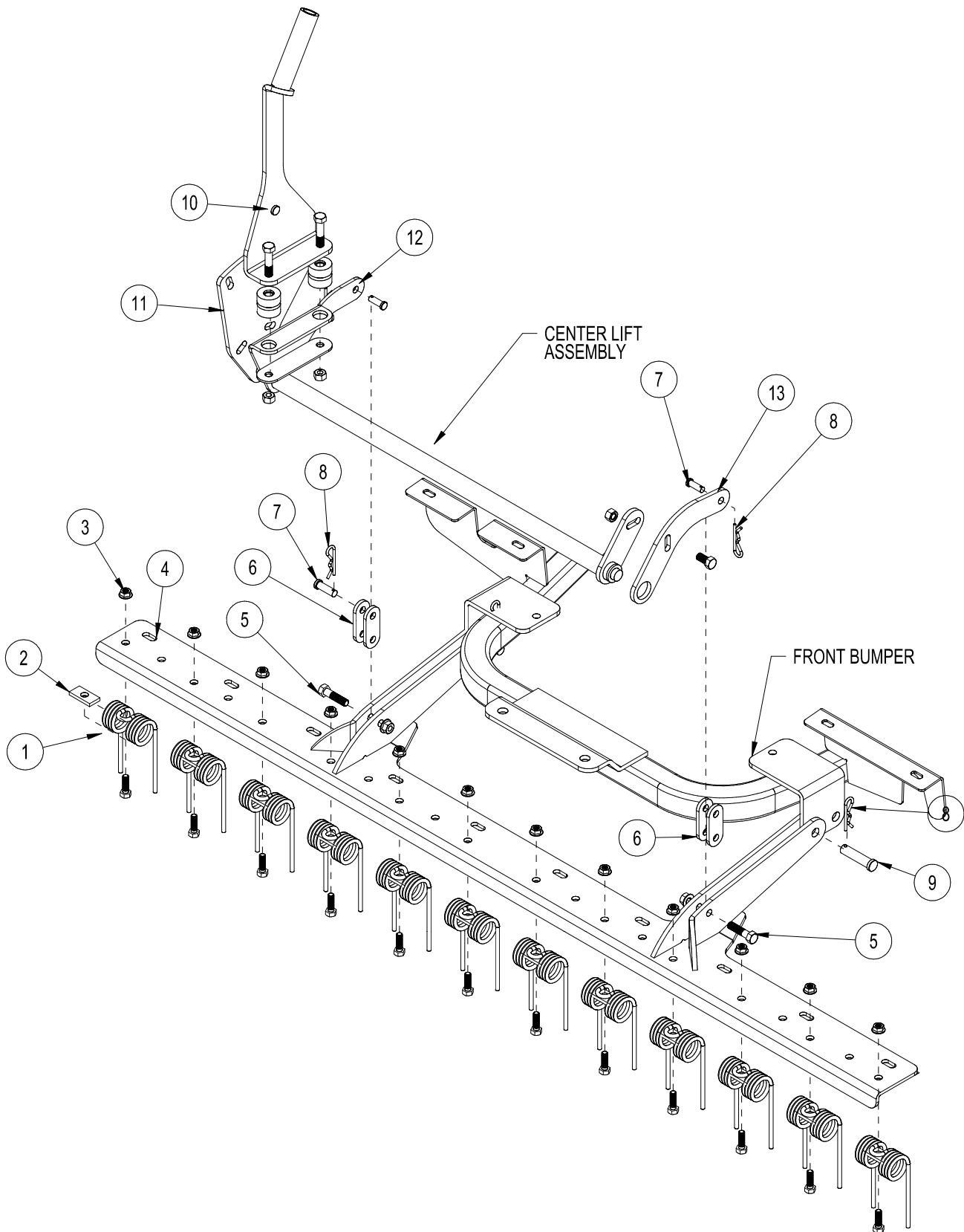

Accessories

41-022 SAND CULTIVATOR PARTS LIST

REF#	PART#	DESCRIPTION	QTY
1	42-122	Rake Spring	12
2	42-177	Spring Holder	12
3	HB-516-18-150	Hex Bolt, $\frac{5}{16}$ -18 x $1\frac{1}{2}$	12
	HNFL-516-18	Flange Whiz-Loc Nut, $\frac{5}{16}$ - 18	12
4	41-074	Center Lift Bar	1
5	HB-38-16-150	Hex Bolt, $\frac{3}{8}$ -16 x $1\frac{1}{2}$	2
	HNTL-38-16	Lock Nut, $\frac{3}{8}$ - 16	2
6	41-040	Lift Link	4
7	HCP-38-113	Clevis Pin, $\frac{3}{8}$ X $1\frac{1}{8}$	4
8	HHP-18	Bridge Pin, $\frac{1}{8}$	6
9	HCP-12-150	Clevis Pin, $\frac{1}{2}$ x $1\frac{1}{2}$	2
10*	41-066	Center Lift Handle	1
11*	41-062	Lift Lock	1
12*	41-065	Center Lift	1
13*	41-043	Lift Mount Brace	1
*	Part of machine		

INSTALLATION INSTRUCTIONS

1. Spring tines (Ref 1) should be bolted to the center lift bar (Ref 4). Slide the spring holder (Ref 2) into the spring and bolt to center lift bar using the $\frac{5}{16}$ - 16 x $1\frac{1}{2}$ bolts and lock nuts (Ref 3).
2. Attach lift links (Ref 6) to center lift bar (Ref 4) using $\frac{3}{8}$ x $1\frac{1}{2}$ bolt and lock nut (Ref 5)provided.
3. Attach the assembled center lift bar to the front bumper using the clevis pin and bridge pin (Ref 8 & 9).
4. Using Center lift handle (Ref 10), lower center lift assembly to bottom slot on lift lock (Ref 11). Attach Lift Links (Ref 6) to the center lift (Ref 12) and the lift mount brace (Ref 13). secure with clevis and bridge pin (Ref 7 & 8)
5. This is a manual lift attachment. There is a pin that is welded to the lift handle (Ref 10). Flex handle inwards to remove pin from lift lock slot and lower center lift to next slot on lift lock (Ref 11). Continue lowering lift handle until you reach desired cultivating depth or the last slot on lift lock.
6. Test for proper operation.

NOTE: For a complete break down of the center lift assembly parts refer to the Rear and Center Lift drawing in the parts manual.

41-023 INFIELD SCARIFIER DRAWING

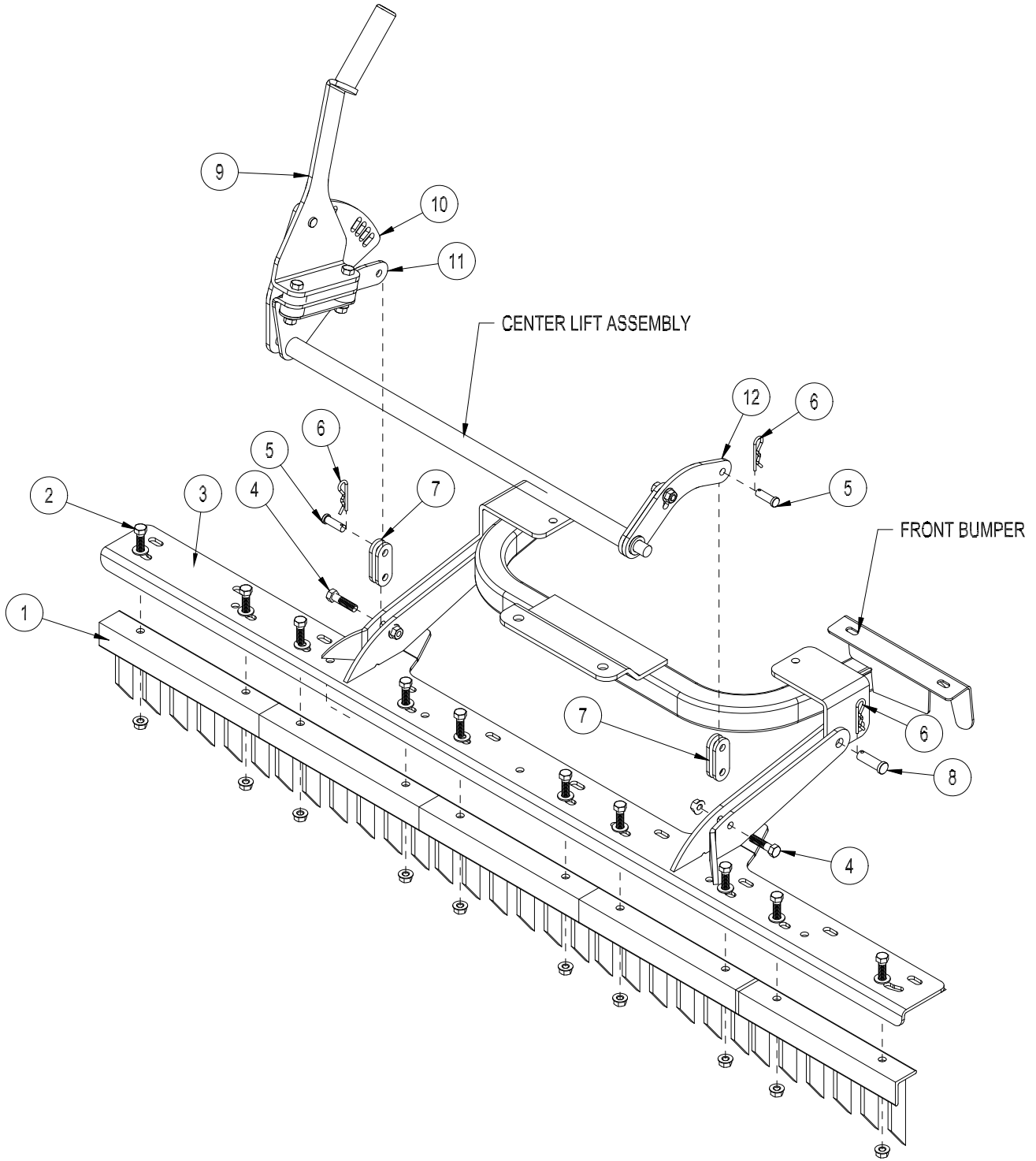

Accessories

41-023 INFIELD SCARIFIER PARTS LIST

REF#	PART#	DESCRIPTION	QTY
1	26-042	Tine Segment	5
2	HB-38-16-100	Hex Bolt, $\frac{3}{8}$ - 16 x 1	10
	HW-38	Flat Washer, $\frac{3}{8}$	10
	HNTL-38-16	Lock Nut, $\frac{3}{8}$ - 16	10
3	41-073	Center Lift Bar	1
4	HB-38-16-150	Hex Bolt, $\frac{3}{8}$ -16 x 1 $\frac{1}{2}$	2
	HNTL-38-16	Lock Nut, $\frac{3}{8}$ - 16	2
5	HCP-38-113	Clevis Pin, $\frac{3}{8}$ X 1 $\frac{1}{8}$	2
6	HHP-18	Bridge Pin, $\frac{1}{8}$	4
7	41-040	Lift Link	4
8	HCP-12-150	Clevis Pin, $\frac{1}{2}$ x 1 $\frac{1}{2}$	2
9*	41-066	Center Lift Handle	1
10*	41-062	Lift Lock	1
11*	41-065	Center Lift	1
12*	41-043	Lift Mount Brace	1

* Part of machine

INSTALLATION INSTRUCTIONS

1. Tine segments (Ref 1) should be bolted to the center lift bar (Ref 3). Use the $\frac{3}{8}$ - 16 x 1 bolts, washers and lock nuts (Ref 2).
2. Attach lift links (Ref 7) to center lift bar (Ref 3) using $\frac{3}{8}$ x 1 $\frac{1}{2}$ bolt and lock nut (Ref 4) provided.
3. Attach the assembled center lift bar to the front bumper using the clevis pin and bridge pin (Ref 8 & 6).
4. Using Center lift handle (Ref 9), lower center lift assembly to bottom slot on lift lock (Ref 10). Attach Lift Links (Ref 7) to the center lift (Ref 11) and the lift mount brace (Ref 12). secure with clevis and bridge pin (Ref 5 & 6)
5. This is a manual lift attachment. There is a pin that is welded to the lift handle (Ref 9). Flex handle inwards to remove pin from lift lock slot and lower center lift to next slot on lift lock (Ref 9). Continue lowering lift handle until you reach desired cultivating depth or the last slot on lift lock.
6. Test for proper operation.

NOTE: For a complete break down of the center lift assembly parts refer to the Rear and Center Lift drawing in the parts manual.

42-391Q 72"(183CM) ProBrush TOURNAMENT RAKE DRAWING

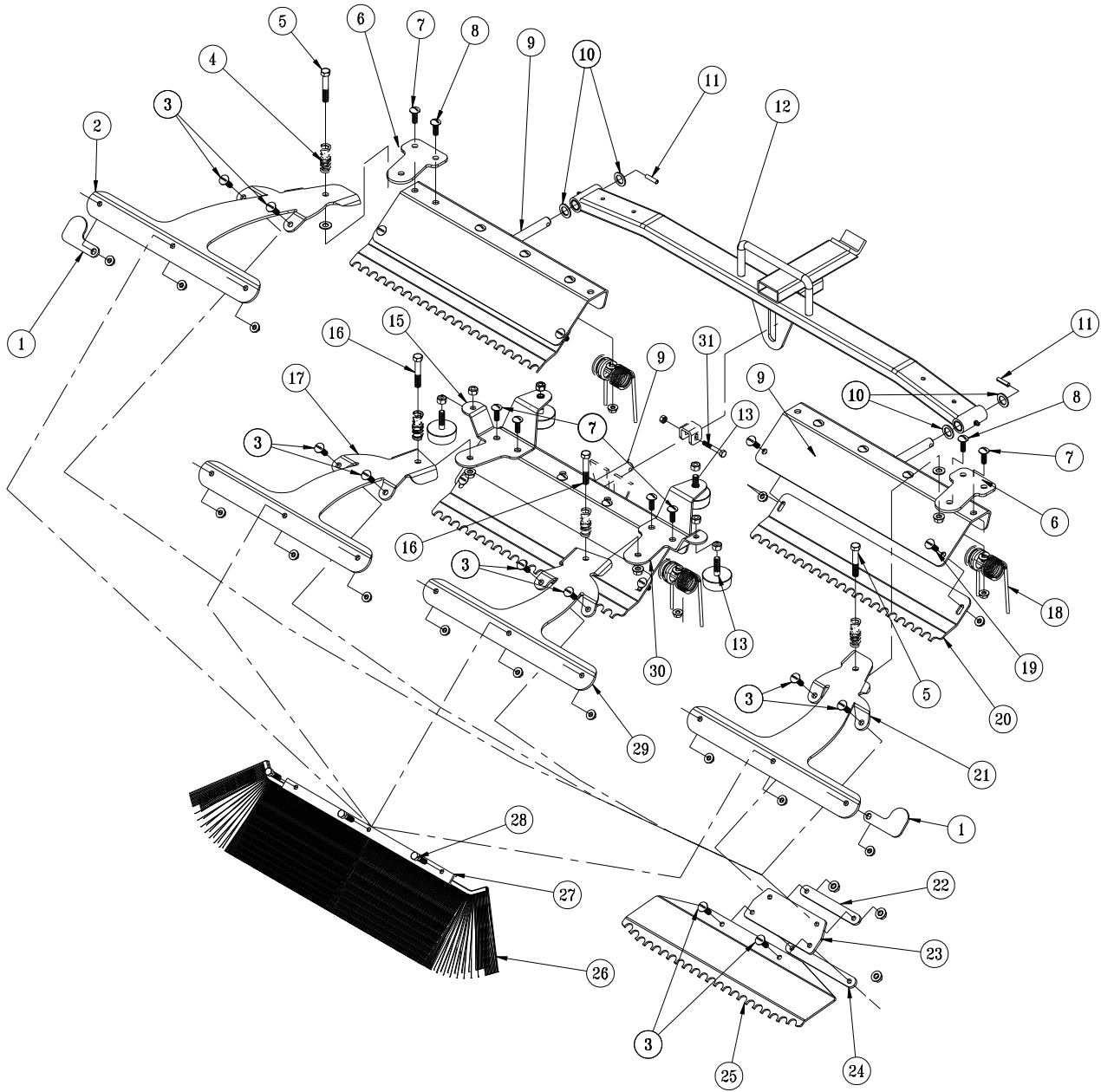

Accessories

42-391Q 72"(183CM) ProBrush TOURNAMENT RAKE PARTS LIST

REF#	PART#	DESCRIPTION	QUANTITY
1	42-489	Tip Guard	2
2	42-397	Outside Brush Arm, LH	1
3	HSTP-516-18-100	Phillip Truss Head Screw, $\frac{5}{16}$ - 18 x 1	16
	HNFL-516-18	Flange Whiz-Loc Nut, $\frac{5}{16}$ - 18	16
4	11-055	Compression Spring	4
5	HB-38-16-275	Hex Bolt, $\frac{3}{8}$ - 16 x 2 $\frac{1}{4}$	2
	HW-38	Flat Washer, $\frac{3}{8}$	2
	HNTL-38-16	Nylon Lock Nut, $\frac{3}{8}$ - 16	2
6	42-396	Outside Brush Arm Mount	2
7	HSTP-516-18-100	Phillips Truss Head Screw, $\frac{5}{16}$ - 18 x 1	4
	HNFL-516-18	Flange Whiz-Loc Nut, $\frac{5}{16}$ - 18	4
8	HSTP-516-18-125	Phillips Truss Head Screw, $\frac{5}{16}$ - 18 x 1 $\frac{1}{4}$	12
	HNFL-516-18	Flange Whiz-Loc Nut, $\frac{5}{16}$ - 18	12
9	42-140	Outside Rake	3
10	HMB-58-14	Machine Bushing $\frac{5}{8}$ x 14GA	4
11	HRP-14-100	Roll Pin $\frac{1}{4}$ x 1	2
12	43-154	Draw Bar	1
	20-018	Oilite Bushing (comes with 43-154)	4
13	50-081	Rubber Bumper	4
	HNFL-38-16	Flange Whiz-Loc Nut, $\frac{3}{8}$ - 16	6
15	42-399	Brush Arm Mount, LH	1
16	HB-38-16-250	Hex Bolt, $\frac{3}{8}$ - 16 x 2 $\frac{1}{2}$	2
	HNTL-38-16	Nylon Lock Nut, $\frac{3}{8}$ - 16	2
17	42-454	Inside Brush Arm, LH	1
18	42-122	Rake Spring	12
	42-177	Spring Holder	12
19	HSTP-516-18-075	Phillip Truss Head Screw, $\frac{5}{16}$ - 18 x $\frac{3}{4}$	6
	HNFL-516-18	Flange Whiz-Loc Nut $\frac{5}{16}$ - 18	6
20	42-171	Groomer Blades	3
21	42-393	Outside Brush Arm, RH	1
22	42-105	Top Strap	4
23	42-107	Matting	4
24	42-106	Bottom Strap	4
25	42-170	Finishing Blades	4
26	42-466	Brush, 21"	4
27	42-465	Brush Clamp	4
28	HB-516-18-125	Hex Bolt, $\frac{5}{16}$ - 18 x 1 $\frac{1}{4}$ - 18	12
29	42-453	Inside Brush Arm, RH	1
30	42-398	Brush Arm Mount, RH	1
31	HB-14-20-175	Hex Bolt, $\frac{1}{4}$ - 20 x 1 $\frac{3}{4}$	1
	HNTL-14-20	Nylon Lock Nut, $\frac{1}{4}$ - 20	1

42-391Q 72"(183CM) ProBrush TOURNAMENT RAKE DRAWING

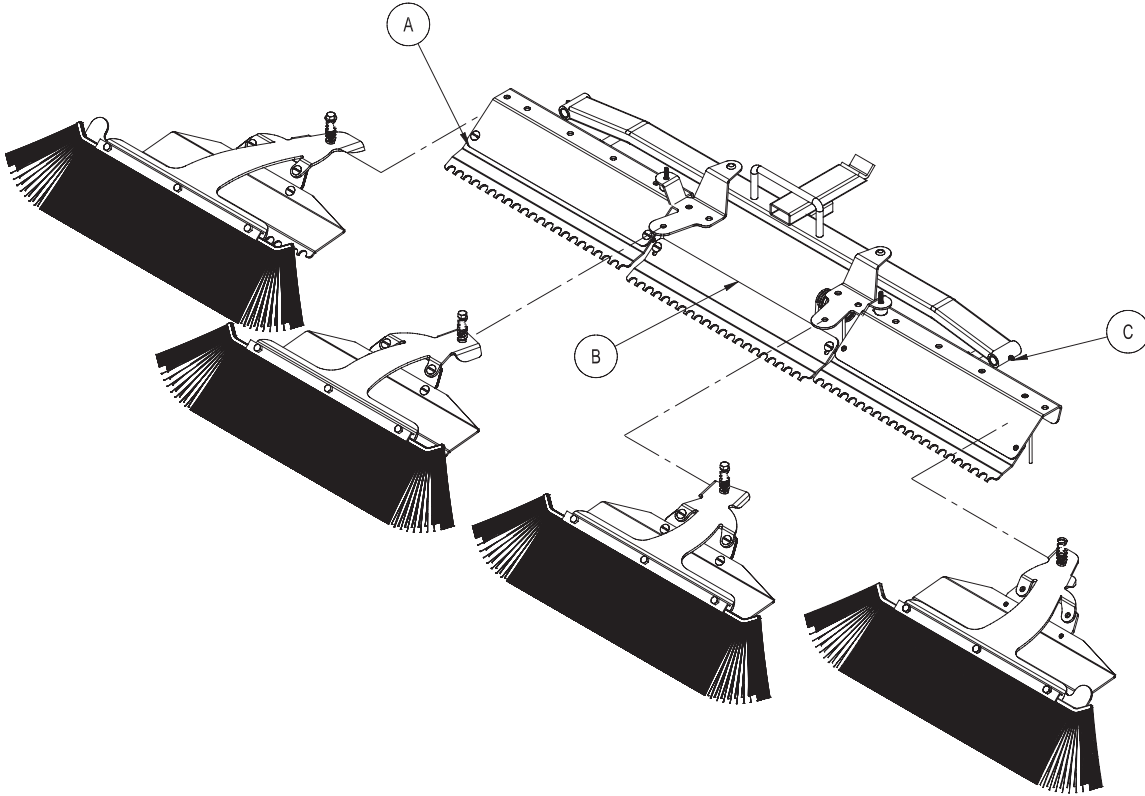

Fig. 1

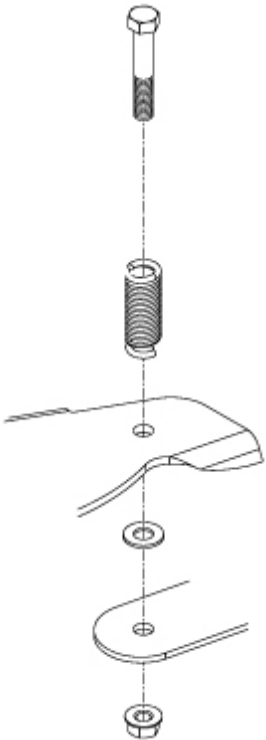

Fig. 2



Fig. 3

Accessories

PROBRUSH TOURNAMENT RAKE ASSEMBLY INSTRUCTIONS

Your **ProBrush TOURNAMENT RAKE** comes mostly assembled.

1. Before assembly please note the two Brush/Finish Blade Assemblies (Refs A & C in Fig.1) that are mounted on the outside (RH & LH) have flat washers that are between the Brush Arms (Refs 2 & 21) and the Brush Arm Mount (Ref 6).
2. Also please note the placement of the Brush/Finish Blade Assemblies as illustrated in Fig 1. They must be mounted as illustrated to work as intended.
3. Begin assembling your **ProBrush TOURNAMENT RAKE** by inserting the Outside and Center Groomer Blade Assemblies (Refs A, B & C in Fig.1) in their locations as illustrated. Secure the Outside Assemblies with the $\frac{1}{4}$ " Pin (Ref 11) and the Center Assembly with the $\frac{1}{4}$ " x $1\frac{3}{4}$ " Hex Bolt and Nylon Lock Nut (Ref 31).
4. Mount the Brush/Finish Blade Assemblies to the Brush Arm Mounts (Refs 6, 30 & 15) as illustrated using the $\frac{3}{8}$ " x $2\frac{1}{2}$ " Hex Bolts and Nylon Lock Nuts. Assemble with the Springs (Ref 4) as shown in Fig. 2. Please note that the $\frac{3}{8}$ " Flat Washers are used only on the Outside Assemblies. Secure when assembled.
5. Mount your **ProBrush TOURNAMENT RAKE** to the trap rake quick hitch. Position the Rake so it is centered and equal distance away from the right and left hand tires (2-3 inches). Fig. 4. Once positioned, set the Adjustment Screws on the Hitch so they touch the trap rake hitch. Fig. 5.
6. Run machine and test for operation of the Rake by raising and lowering the assembly and with rake down turn sharp corners in both directions to ensure rake is not contacting the tires. Test Rake in sand to ensure tire tracks are covered when turning sharp corners. If the tire tracks are not covered by the Rake, turn the Adjustment Screws on the Rake Hitch so the rake comes closer to the tires when turning. For reference see Fig. 4 and 5 below.

NOTE:

The Outside Brush/Finish Blade Assemblies may be rotated 180° for transport and for working in narrow areas, as illustrated in Fig.3 on the facing page.

Fig. 4

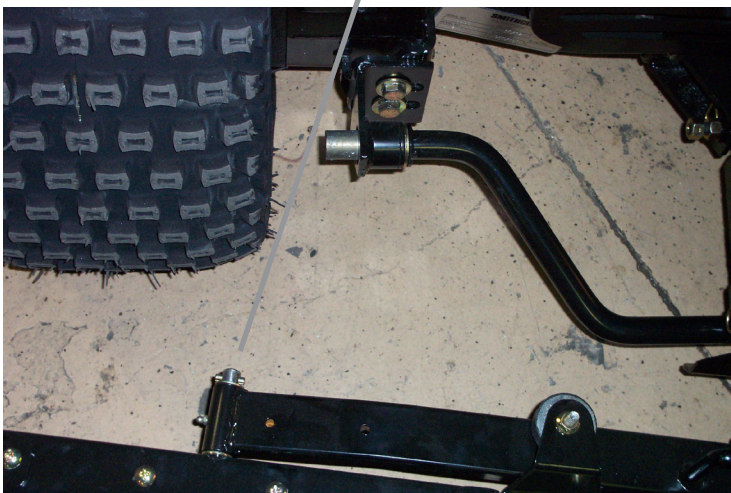

Adjustment Screws

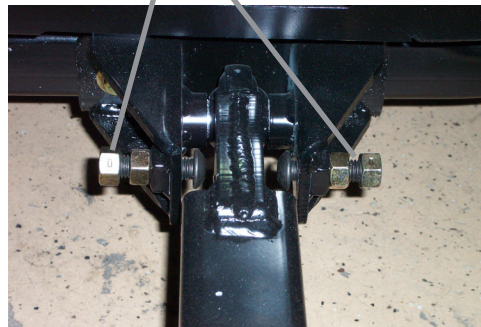
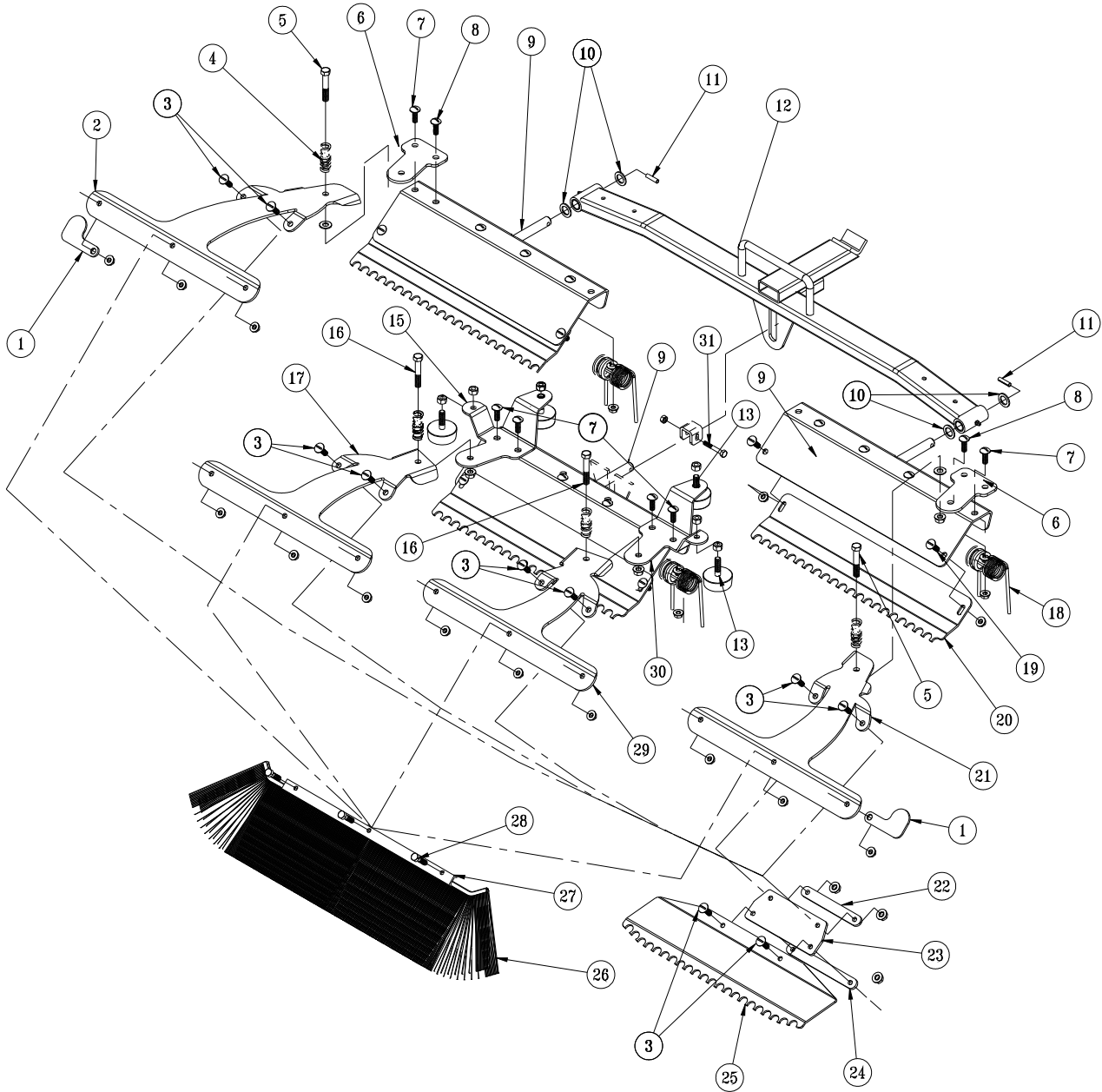

Fig. 5

42-392Q 84"(213CM) ProBRUSH TOURNAMENT RAKE DRAWING



Accessories

42-392Q 84"(213CM) ProBrush TOURNAMENT RAKE PARTS LIST

REF#	PART#	DESCRIPTION	QUANTITY
1	42-489	Tip Guard	2
2	42-397	Outside Brush Arm, LH	1
3	HSTP-516-18-100	Phillip Truss Head Screw, $\frac{5}{16}$ - 18 x 1	16
	HNFL-516-18	Flange Whiz-Loc Nut, $\frac{5}{16}$ - 18	16
4	11-055	Compression Spring	4
5	HB-38-16-250	Hex Bolt, $\frac{3}{8}$ - 16 x 2 $\frac{1}{2}$	2
	HW-38	Flat Washer, $\frac{3}{8}$	2
	HNTL-38-16	Nylon Lock Nut, $\frac{3}{8}$ - 16	2
6	42-396	Outside Brush Arm Mount	2
7	HSTP-516-18-100	Phillips Truss Head Screw, $\frac{5}{16}$ - 18 x 1	4
	HNFL-516-18	Flange Whiz-Loc Nut, $\frac{5}{16}$ - 18	4
8	HSTP-516-18-125	Phillips Truss Head Screw, $\frac{5}{16}$ - 18 x 1 $\frac{1}{4}$	12
	HNFL-516-18	Flange Whiz-Loc Nut, $\frac{5}{16}$ - 18	12
9	42-102	84" Outside Rake	3
10	HMB-58-14	Machine Bushing, $\frac{5}{8}$ x 14GA	4
11	HRP-14-100	Roll Pin, $\frac{1}{4}$ x 1	2
12	43-144	84" Draw Bar	1
13	50-081	Rubber Bumper	4
	HNFL-38-16	Flange Whiz-Loc Nut, $\frac{3}{8}$ - 16	6
15	42-399	Brush Arm Mount, LH	1
16	HB-38-16-250	Hex Bolt, $\frac{3}{8}$ - 16 x 2 $\frac{1}{2}$	2
	HNTL-38-16	Nylon Lock Nut, $\frac{3}{8}$ - 16	2
17	42-454	Inside Brush Arm, LH	1
18	42-122	Rake Spring	12
	42-177	Spring Holder	12
19	HSTP-516-18-075	Phillip Truss Head Screw, $\frac{5}{16}$ - 18 x $\frac{3}{4}$	6
	HNFL-516-18	Flange Whiz-Loc Nut, $\frac{5}{16}$ - 18	6
20	42-129	Groomer Blades	3
21	42-393	Outside Brush Arm, RH	1
22	42-105	Top Strap	4
23	42-107	Matting	4
24	42-106	Bottom Strap	4
25	42-135	Finishing Blades	4
26	42-466	Brush, 21"	4
27	42-465	Brush Clamp	4
28	HB-516-18-125	Hex Bolt, $\frac{5}{16}$ - 18 x 1 $\frac{1}{4}$	12
	HNFL-516-18	Flange Whiz-Loc Nut, $\frac{5}{16}$ - 18	12
29	42-453	Inside Brush Arm, RH	1
30	42-398	Brush Arm Mount, RH	1
31	HB-14-20-175	Hex Bolt, $\frac{1}{4}$ - 20 x 1 $\frac{3}{4}$	1
	HNTL-14-20	Nylon Lock Nut, $\frac{1}{4}$ - 20	1

42-392Q 84"(213CM) ProBRUSH TOURNAMENT RAKE DRAWING

Fig. 1

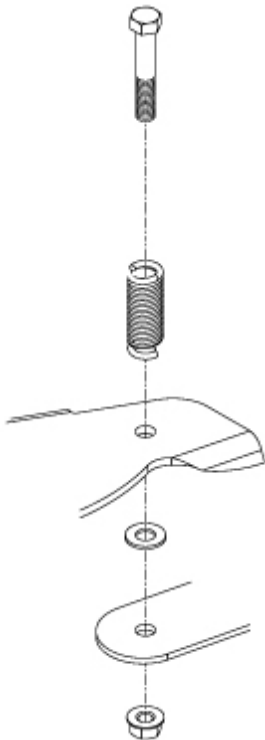
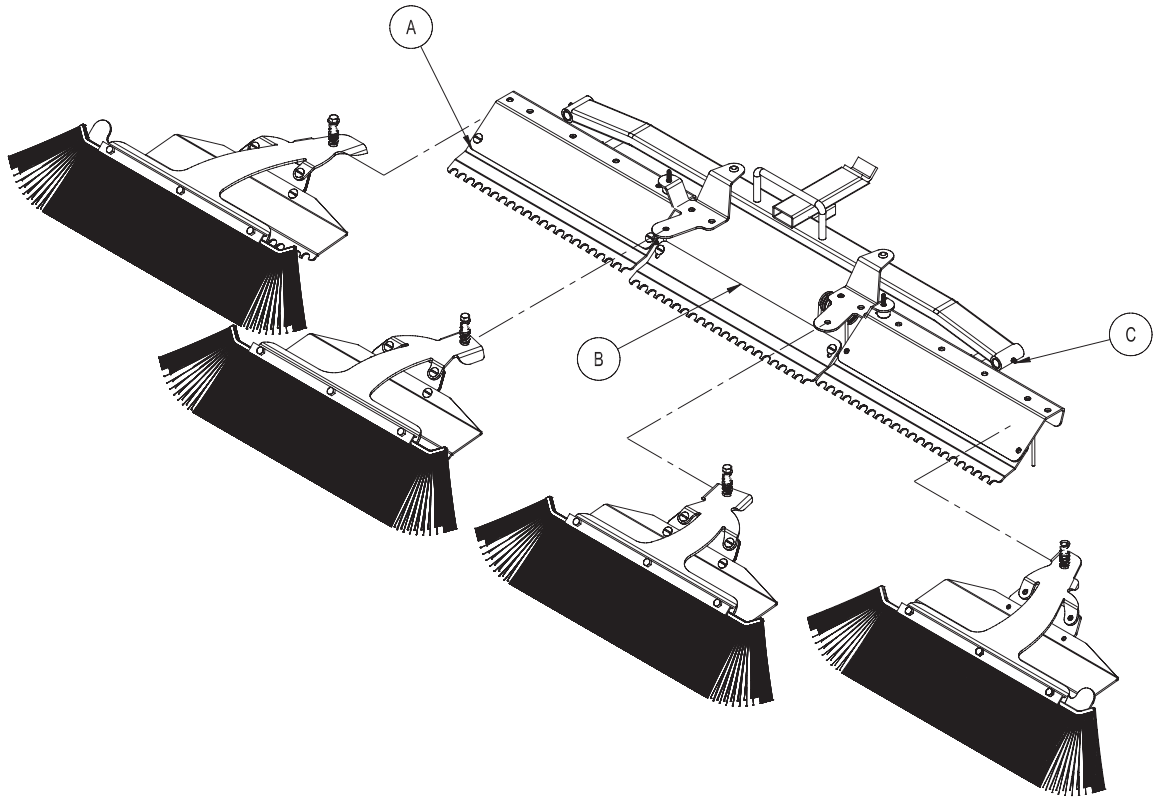

Fig. 2



Fig. 3

Accessories

PROBRUSH TOURNAMENT RAKE ASSEMBLY INSTRUCTIONS

Your **ProBrush TOURNAMENT RAKE** comes mostly assembled.

1. Before assembly please note the two Brush/Finish Blade Assemblies (Refs A & C in Fig.1) that are mounted on the outside (RH & LH) have flat washers that are between the Brush Arms (Refs 2 & 21) and the Brush Arm Mount (Ref 6).
2. Also please note the placement of the Brush/Finish Blade Assemblies as illustrated in Fig 1. They must be mounted as illustrated to work as intended.
3. Begin assembling your **ProBrush TOURNAMENT RAKE** by inserting the Outside and Center Groomer Blade Assemblies (Refs A, B & C in Fig.1) in their locations as illustrated. Secure the Outside Assemblies with the $\frac{1}{4}$ " Pin (Ref 11) and the Center Assembly with the $\frac{1}{4}$ " x $1\frac{3}{4}$ " Hex Bolt and Nylon Lock Nut (Ref 31).
4. Mount the Brush/Finish Blade Assemblies to the Brush Arm Mounts (Refs 6, 30 & 15) as illustrated using the $\frac{3}{8}$ x $2\frac{1}{2}$ Hex Bolts and Nylon Lock Nuts. Assemble with the Springs (Ref 4) as shown in Fig. 2. Please note that the $\frac{3}{8}$ " Flat Washers are used only on the Outside Assemblies. Secure when assembled.
5. Mount your **ProBrush TOURNAMENT RAKE** to the trap rake quick hitch. Position the Rake so it is centered and equal distance away from the right and left hand tires (2-3 inches). Fig. 4. Once positioned, set the Adjustment Screws on the Hitch so they touch the trap rake hitch. Fig. 5.
6. Run machine and test for operation of the Rake by raising and lowering the assembly and with rake down turn sharp corners in both directions to ensure rake is not contacting the tires. Test Rake in sand to ensure tire tracks are covered when turning sharp corners. If the tire tracks are not covered by the Rake, turn the Adjustment Screws on the Rake Hitch so the rake comes closer to the tires when turning. For reference see Fig. 4 and 5 below.

NOTE:

The Outside Brush/Finish Blade Assemblies may be rotated 180° for transport and for working in narrow areas, as illustrated in Fig.3 on the facing page.

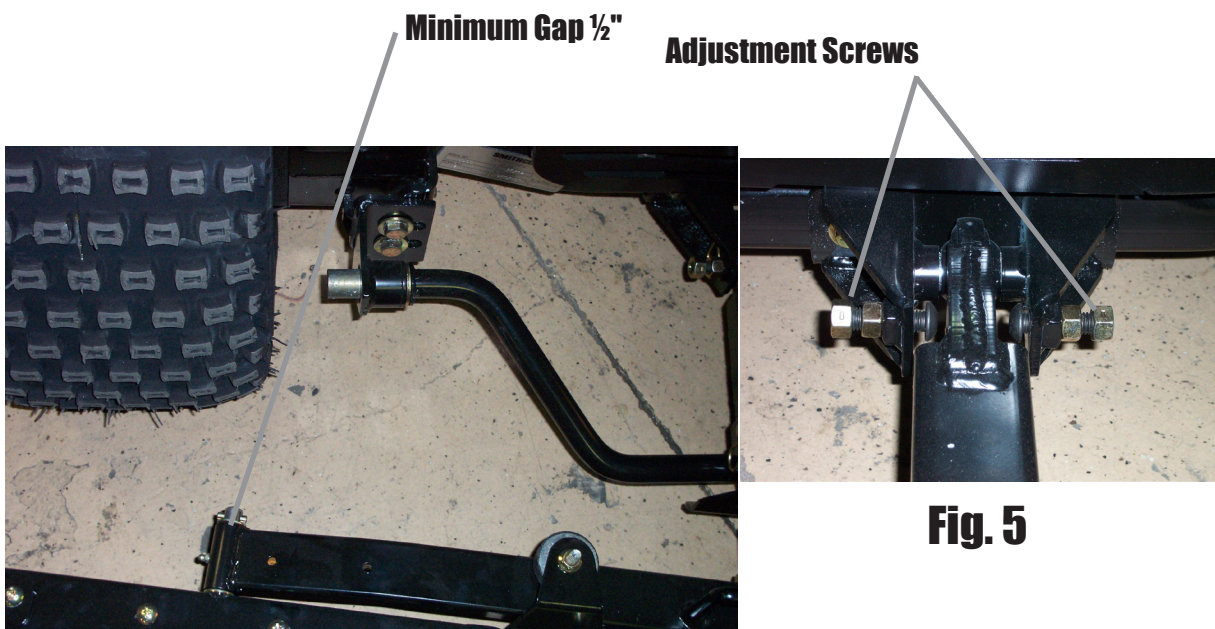

42-130Q 84" (213CM) MILD STEEL TOURNAMENT RAKE DRAWING

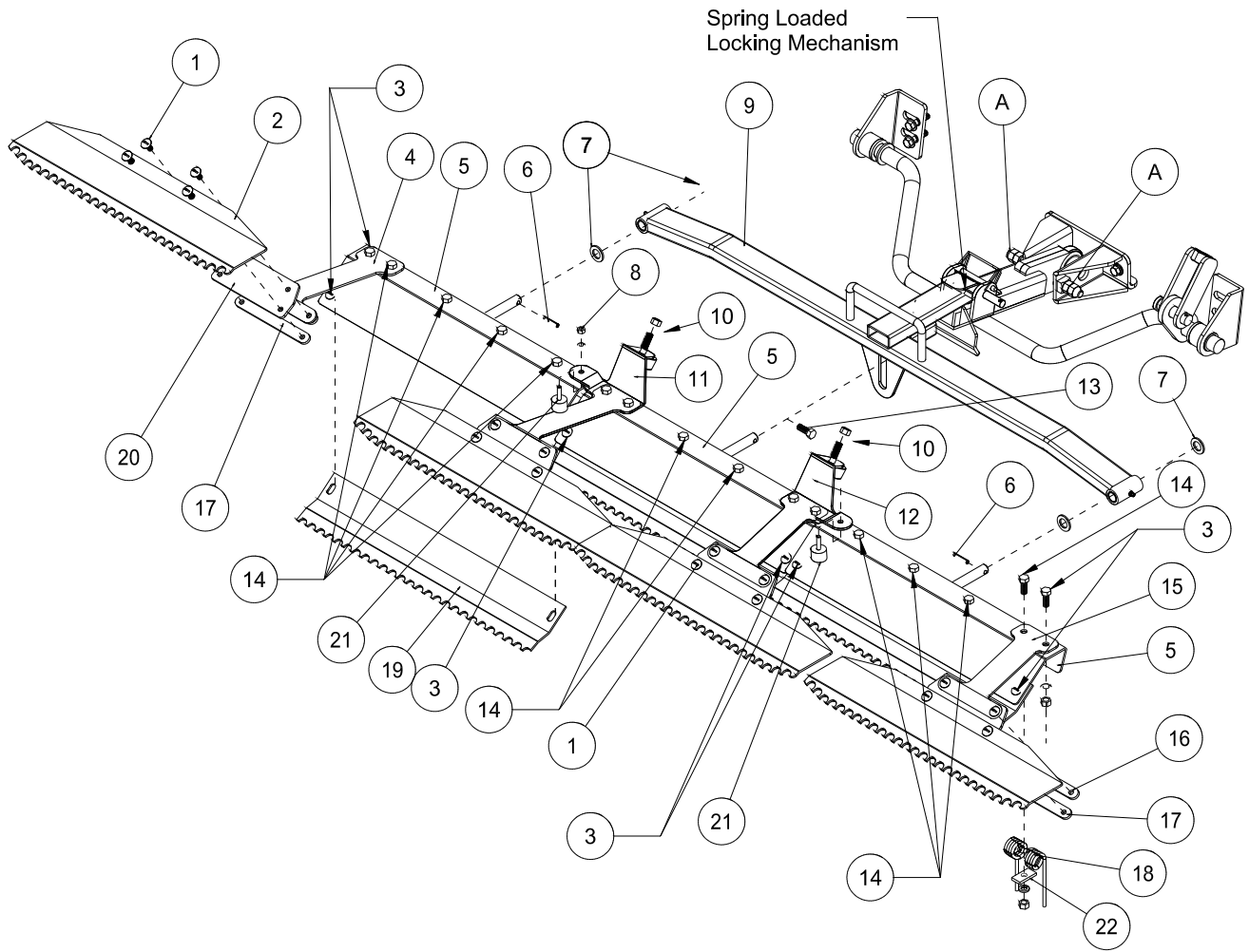

42-130Q 84" (213CM) MILD STEEL TOURNAMENT RAKE PARTS LIST

REF#	PART#	DESCRIPTION	QUANTITY
1	HSTP-516-18-100	Phillips Machine Screw, $\frac{5}{16}$ - 18 x 1	16
	HNFL-516-18	Flange Whiz-Loc Nut, $\frac{5}{16}$ - 18	16
2	42-135	Finishing Blades	4
3	HSTP-516-18-075	Phillips Machine Screw, $\frac{5}{16}$ - 18 x $\frac{3}{4}$	8
	HNFL-516-18	Flange Whiz-Loc Nut, $\frac{5}{16}$ - 18	8
4	42-111	Left Outside Mount	1
5	42-102	Outside Rake	3
6	HRP-14-100	Roll Pin, $\frac{1}{4}$ x 1	2
7	HMB-58-14	Machine Bushing, $\frac{5}{8}$ x 14GA	4
8	HNC-14-20	Cap Nut, $\frac{1}{4}$ - 20	2
	HWL-14	Lock Washer, $\frac{1}{4}$	2
9	43-144	Draw Bar	1
10	50-081	Rubber Bumper	2
11	42-110	Left Inside Mount	1
12	42-108	Inside Trowel Mount	1
13	HB-14-20-175	Hex Bolt, $\frac{1}{4}$ - 20 x $1\frac{3}{4}$	1
	HNTL-14-20	Nylon Lock Nut, $\frac{1}{4}$ - 20	1
14	HSTP-516-18-125	Phillips Machine Screw, $\frac{5}{16}$ - 18 x $1\frac{1}{4}$	12
	HNFL-516-18	Flange Whiz-Loc Nut, $\frac{5}{16}$ - 18	12
15	42-109	Outside Towel Mount	1
16	42-105	Top Strap	4
17	42-106	Bottom Strap	4
18	42-122	Rake Spring	12
19	42-129	Groomer Blades	3
20	42-107	Matting	4
21	15-013	Rubber Bumper	2
22	42-177	Spring Holder	12

42-130Q 84" (213CM) MILD STEEL TOURNAMENT RAKE DRAWING

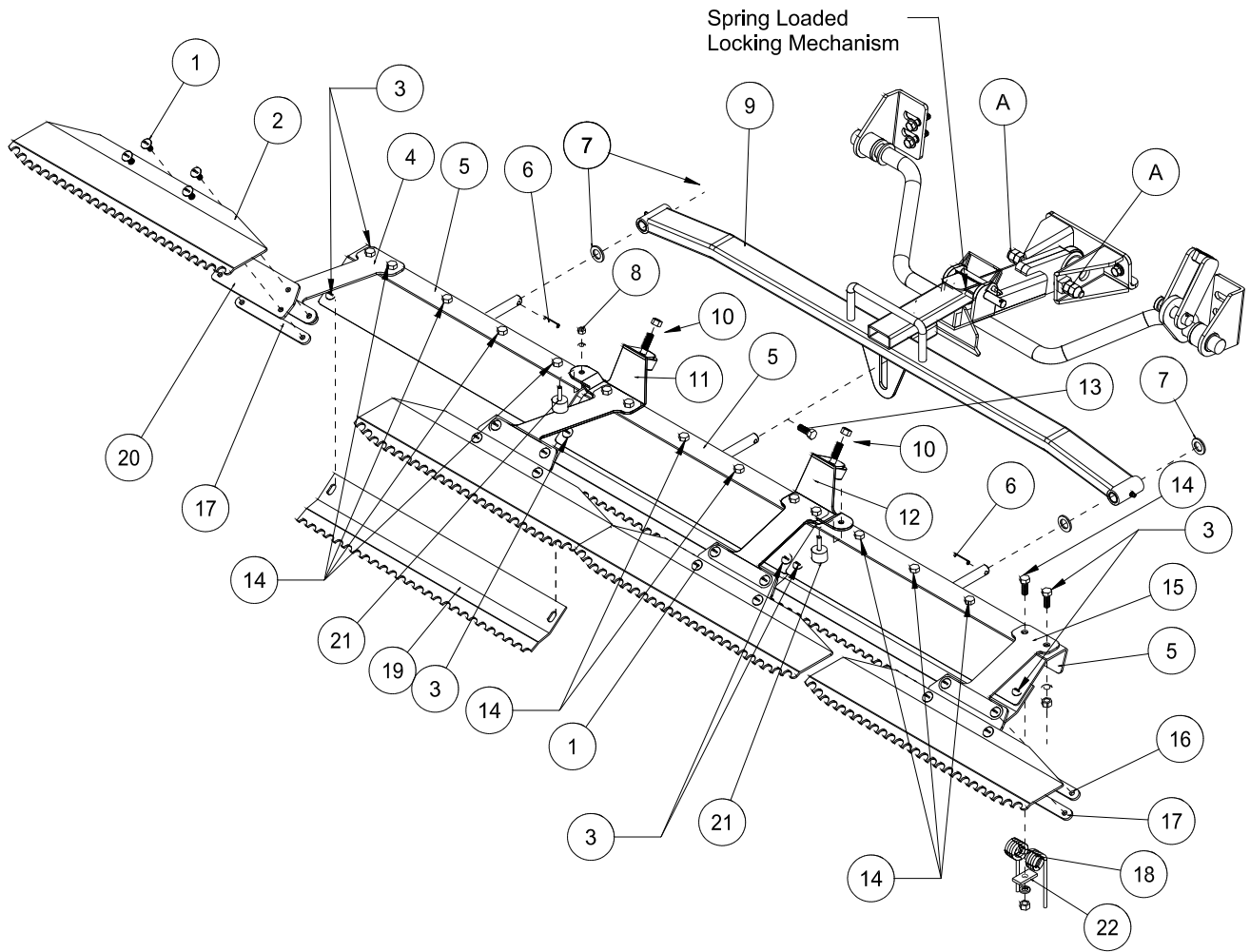

RAKE ASSEMBLY INSTRUCTIONS

1. Hex Bolt rake spring (Ref 18) to rake frames (Ref 5) using hardware (Ref 14). Leave the two outside holes on right, left, and center rake open.
2. Attach rubber bumper (Ref 21) using cap nut and washer (Ref 8). Attach rubber grommet (Ref 10) to inside mounts (Ref 11 & 12)
3. Attach the left outside mount (Ref 4), the left inside mount (Ref 11), the outside trowel mount (Ref 15), and the inside trowel mount (Ref 12) to the outside and center rakes (Ref 5) as shown. Use the $\frac{3}{4}$ " truss head screws (Ref 3) on the outside hole of each rake. Use the spring holder (Ref 22) and the $1\frac{1}{4}$ " truss head screws (Ref 14) to attach rake springs (Ref 18) to the rakes under the left outside and inside mounts and the outside and inside trowel mounts.
4. Slide a machine bushing onto outside rake frames then slide the outside rake frames (Ref 5) into the tubing on the end of the drawbar. Hold in place with another machine bushing and a roll pin (Ref 6).
5. Attach center rake (Ref 5) to draw bar (Ref 9) as shown, using $1\frac{3}{4}$ Hex Bolts and Nylon Lock Nuts (Ref 13) with the shaft of the center rake in the slot on the bottom of the drawbar.
6. Attach the matting (Ref 20) and the top strap (Ref 16) to the inside and outside mounts using the truss head screw $\frac{5}{16}$ - 18 x 1 (Ref 1). Attach four finishing blades (Ref 2) to the matting on the inside and outside mounts with the truss head screw $\frac{5}{16}$ - 18 x 1 (Ref 1) going through the finishing blade, matting, and bottom strap (Ref 17).
7. Place the three groomer blades (Ref 19) under the three rake assemblies as shown, using (Ref 3).
8. Attach the rake lift to the trap rake quick hitch, by sliding the the hitch into the spring loaded locking mechanism.
9. With the rake on the ground pull the rake to the right side until it is 2-3 inches from the tire.
10. Using the adjustment Hex Bolts (Ref A) on the side of hitch, adjust the Hex Bolts until it hits the trap rake hitch. Lock jam nut so adjustment will not change.
11. Repeat steps for the left side.
12. Turn machine on and test for operation of rake assembly by raising and lowering the rake assembly. Also with rake down, turn sharp corners to check that rake does not touch wheels.

NOTE: Test rake in sand to assure tire tracks are covered by the rake when turning sharp corners in either direction. If there are tire tracks, readjust using the adjusting screws on the hitch, so the rake comes closer to the tire.

42-132Q 72" (183CM) MILD STEEL TOURNAMENT RAKE DRAWING

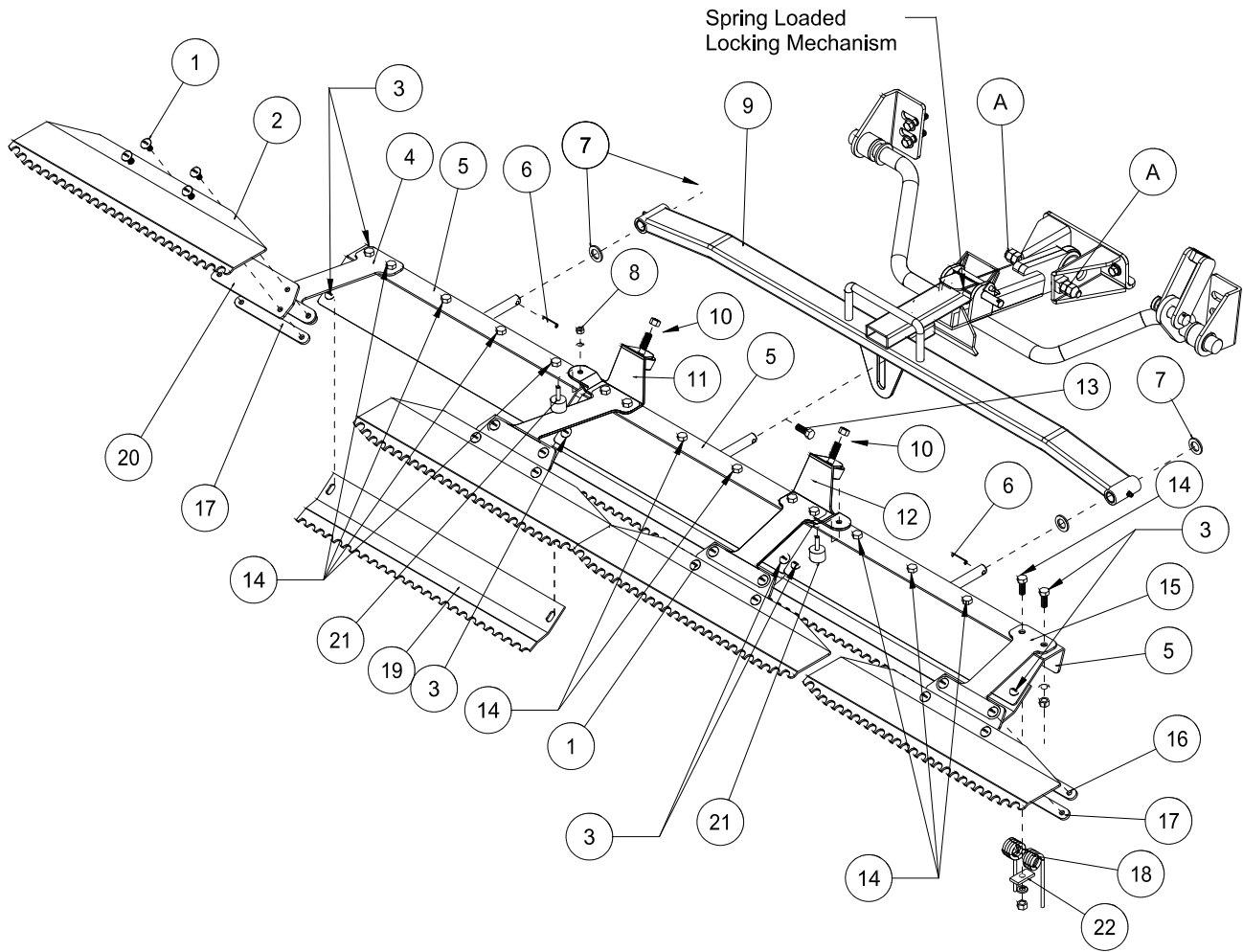

42-132Q 72"(183CM) MILD STEEL TOURNAMENT RAKE PARTS LIST

REF#	PART#	DESCRIPTION	QUANTITY
1	HSTP-516-18-100	Phillips Machine Screw, $\frac{5}{16}$ - 18 x 1	16
	HNFL-516-18	Flange Whiz-Loc Nut, $\frac{5}{16}$ - 18	16
2	42-170	Finishing Blades	4
3	HSTP-516-18-075	Phillips Machine Screw, $\frac{5}{16}$ - 18 x $\frac{3}{4}$	10
	HNFL-516-18	Flange Whiz-Loc Nut, $\frac{5}{16}$ - 18	10
4	42-111	Left Outside Mount	1
5	42-140	Outside Rake	3
6	HRP-14-100	Roll Pin, $\frac{1}{4}$ x 1	2
7	HMB-58-14	Machine Bushing, $\frac{5}{8}$ x 14GA	4
8	HNC-14-20	Cap Nut, $\frac{1}{4}$ - 20	2
	HWL-14	Lock Washer, $\frac{1}{4}$	2
9	43-154	Draw Bar	1
	20-018	Oilite Bushing (comes with 43-154)	4
10	50-081	Rubber Bumper	2
	HNFL-38-16	Flange Whiz-Loc Nut, $\frac{3}{8}$ - 18	2
11	42-110	Left Inside Mount	1
12	42-108	Inside Trowel Mount	1
13	HB-14-20-175	Hex Bolt, $\frac{1}{4}$ - 20 x $1\frac{3}{4}$	1
	HNTL-14-20	Nylon Lock Nut, $\frac{1}{4}$ - 20	1
14	HSTP-516-18-125	Phillips Machine Screw, $\frac{5}{16}$ - 18 x $1\frac{1}{4}$	12
	HNFL-516-18	Flange Whiz-Loc Nut, $\frac{5}{16}$ - 18	12
15	42-109	Outside Towel Mount	1
16	42-105	Top Strap	4
17	42-106	Bottom Strap	4
18	42-122	Rake Spring	12
19	42-171	Groomer Blades	3
20	42-107	Matting	4
21	15-013	Rubber Bumper	2
22	42-177	Spring Holder	12

42-132Q 72"(183CM) MILD STEEL TOURNAMENT RAKE DRAWING

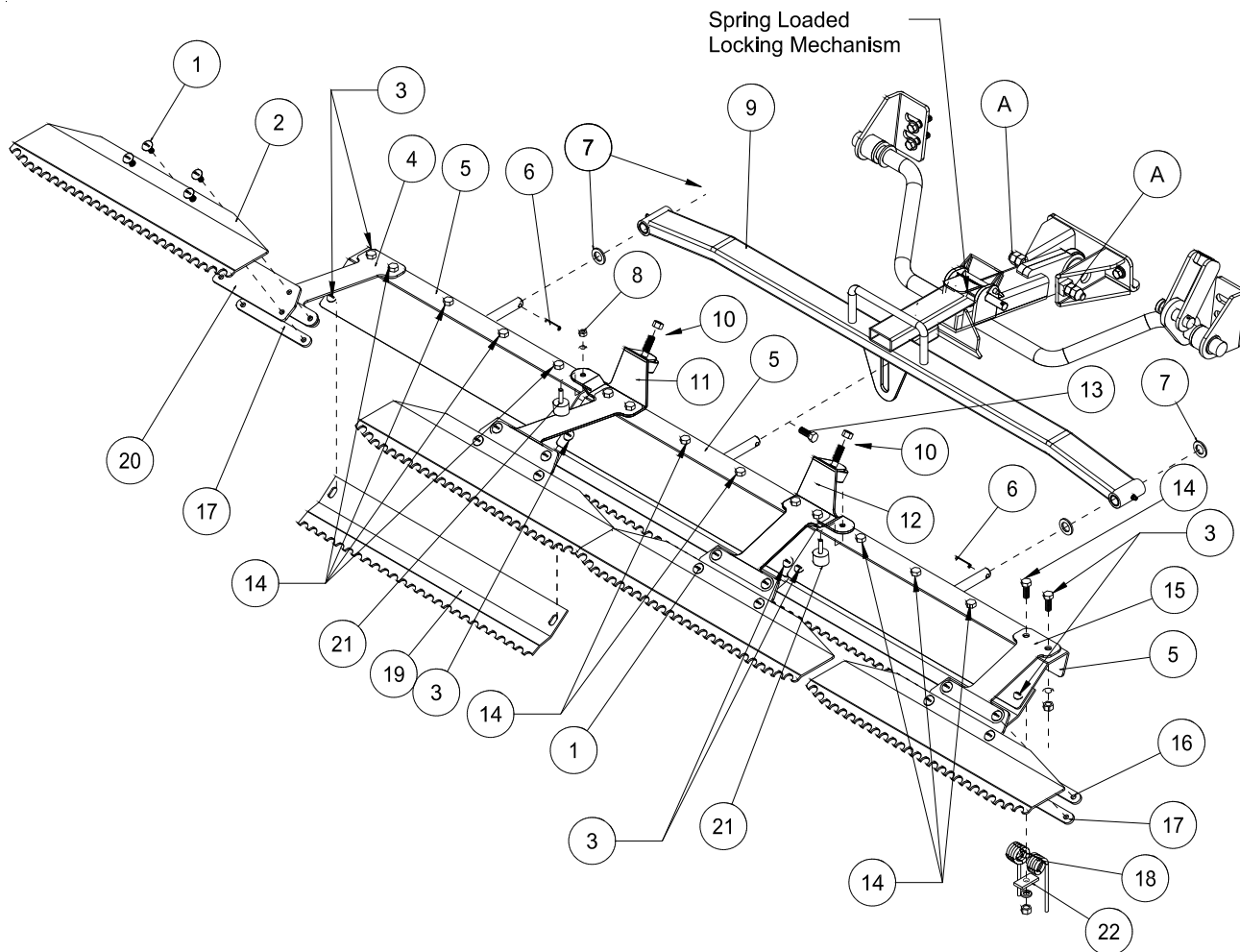

RAKE ASSEMBLY INSTRUCTIONS

1. Hex Bolt rake spring (Ref 18) to rake frames (Ref 5) using hardware (Ref 14). Leave the two outside holes on right, left, and center rake open.
 2. Attach rubber bumper (Ref 21) using cap nut and washer (Ref 8). Attach rubber grommets (Ref 10) to inside mounts (Ref 11 & 12)
 3. Attach the left outside mount (Ref 4), the left inside mount (Ref 11), the outside trowel mount (Ref 15), and the inside trowel mount (Ref 12) to the outside and center rakes (Ref 5) as shown. Use the $\frac{3}{4}$ " truss head screws (Ref 3) on the outside hole of each rake. Use the spring holder (Ref 22) and the $1\frac{1}{4}$ " truss head screws (Ref 14) to attach rake springs (Ref 18) to the rakes under the left outside and inside mounts and the outside and inside trowel mounts.
 4. Slide a machine bushing onto outside rake frames then slide the outside rake frames (Ref 5) into the tubing on the end of the drawbar. Hold in place with another machine bushing and a roll pin (Ref 6).
 5. Attach center rake (Ref 5) to draw bar (Ref 9) as shown, using $1\frac{3}{4}$ Hex Bolts and Nylon Lock Nuts (Ref 13) with the shaft of the center rake in the slot on the bottom of the drawbar.
 6. Attach the matting (Ref 20) and the top strap (Ref 16) to the inside and outside mounts using the truss head screw $\frac{5}{16}$ - 18 x 1 (Ref 1). Attach four finishing blades (Ref 2) to the matting on the inside and outside mounts with the truss head screw $\frac{5}{16}$ - 18 x 1 (Ref 1) going through the finishing blade, matting, and bottom strap (Ref 17).
 7. Place the three groomer blades (Ref 19) under the three rake assemblies as shown, using (Ref 3).
 8. Attach the rake lift to the trap rake quick hitch, by sliding the the hitch into the spring loaded locking mechanism.
 9. With the rake on the ground pull the rake to the right side until it is 2-3 inches from the tire.
 10. Using the adjustment Hex Bolts (Ref A) on the side of hitch, adjust the Hex Bolts until it hits the trap rake hitch. Lock jam nut so adjustment will not change.
 11. Repeat steps for the left side.
 12. Turn machine on and test for operation of rake assembly by raising and lowering the rake assembly. Also with rake down, turn sharp corners to check that rake does not touch wheels.
- NOTE:** Test rake in sand to assure tire tracks are covered by the rake when turning sharp corners in either direction. If there are tire tracks, readjust using the adjusting screws on the hitch, so the rake comes closer to the tire.

13-758 MAX FLEX SAND RAKE

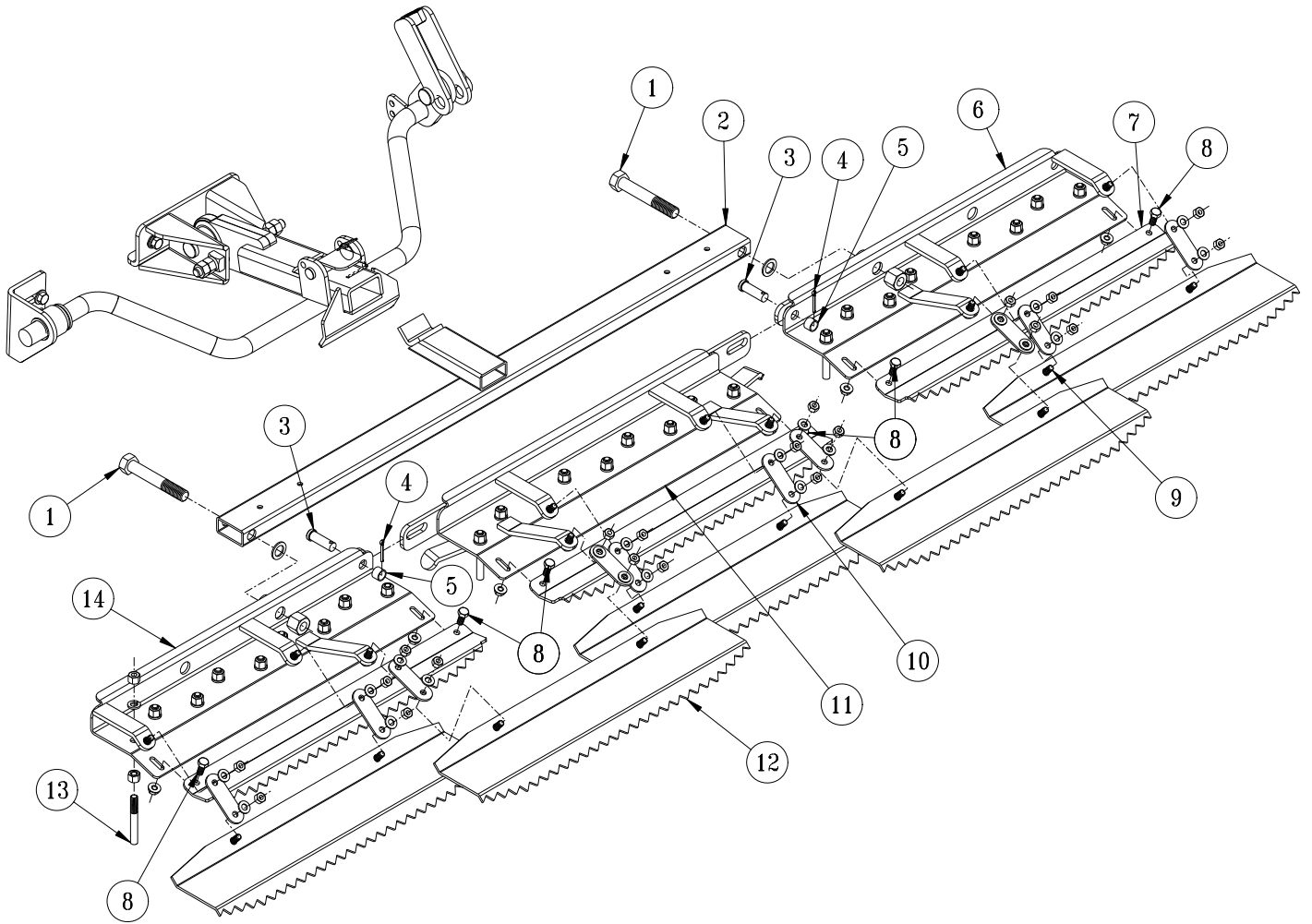

13-758 MAX FLEX SAND RAKE

REF#	PART#	DESCRIPTION	QUANTITY
1	HB-58-11-400	Hex Bolt, $\frac{5}{8}$ - 11 x 4	2
	HMB-58-14	Machine Bushing, $\frac{5}{8}$ x 14GA	2
	HNCL-58-11	Nylon Lock Nut, $\frac{5}{8}$ - 11	2
2	43-145	Draw bar	1
3	HCP-12-150	Clevis Pin, $\frac{1}{2}$ - $1\frac{1}{2}$	2
4	HP-18-100	Cotter Pin, $\frac{1}{8}$ x 1	2
5	76-275	Spacer	2
6	13-762	Right Rake	1
7	13-759	Grooming Blade	3
8	HB-516-18-075	Hex Bolt, $\frac{5}{16}$ - 18 x $\frac{3}{4}$	6
	HNFL-516-18	Flange Whiz-Loc Nut, $\frac{5}{16}$ - 18	6
9	HBFL-516-18-100	Flange Lock Hex Bolt, $\frac{5}{16}$ - 18 x 1	20
	HNTL-516-18	Nylon Lock Nut, $\frac{5}{16}$ - 18	20
	HW-516	Flat Washer, $\frac{5}{16}$	20
10	13-757	Rake Connect Strap	10
11	13-761	QH Center Rake	1
12	13-443	Finishing Blade	5
14	13-763	Left Rake	1
13*	13-445	Rake Teeth Kit (27 Studs and Hardware)	1

INSTALLATION INSTRUCTIONS

- Hex Bolt rake teeth (Ref 13) to frames, keeping all the same length.
- Lay out rake frames (Refs 6, 11 & 14). Connect them using Clevis Pin (Ref 3), Spacer (Ref 5) and Cotter Pin (Ref 4).
- Attach Left Frame (Ref 14) and Right Frame (Ref 6) to Draw bar (Ref 2) using $\frac{5}{8}$ Hex Bolt, Machine Bushing, and Center Nylon Lock Nut (Ref 1).
- Attach the three Groomer Blades (Ref 7), one to each of the Rake Frames (Refs 6, 11 & 14) using two Hex Bolts and Flange Whiz-Loc Nuts (Ref 8). Slide Groomer Blades to end of slot and tighten hardware.
- Attach the five Finishing Blades (Ref 12) to the tabs of the rake frames using two Rake Connect Strap (Ref 10) per Finishing blade. Secure using Flange Lock Hex Bolt, Flat Washer and Nylon Lock Nut (Ref 9).

NOTE: Attach Straps using hardware as illustrated, placing Flat Washer on Strap then secure with Nylon Lock Nut. Attaching with the Flange Hex Bolt in contact with the Strap will cause the Strap to bind and misalign Finishing Blade.

- Attach the rake to the trap rake quick hitch by sliding the draw bar hitch into the spring loaded locking mechanism.
- With the rake on the ground pull the rake to the right side until it is 2-3 inches from the tire.
- Repeat steps on left side.
- Turn machine on and test for operation of rake assembly by raising and lowering the rake assembly. Also with rake down, turn sharp corners to check that rake does not touch wheels.
- NOTE:** Test rake in sand to assure tire tracks are covered by the rake when turning sharp corners in either direction. If there are tire tracks, readjust using the adjusting screws on the hitch, so the rake comes closer to the tire.

45-503 84" RAKE ASSEMBLY DRAWING

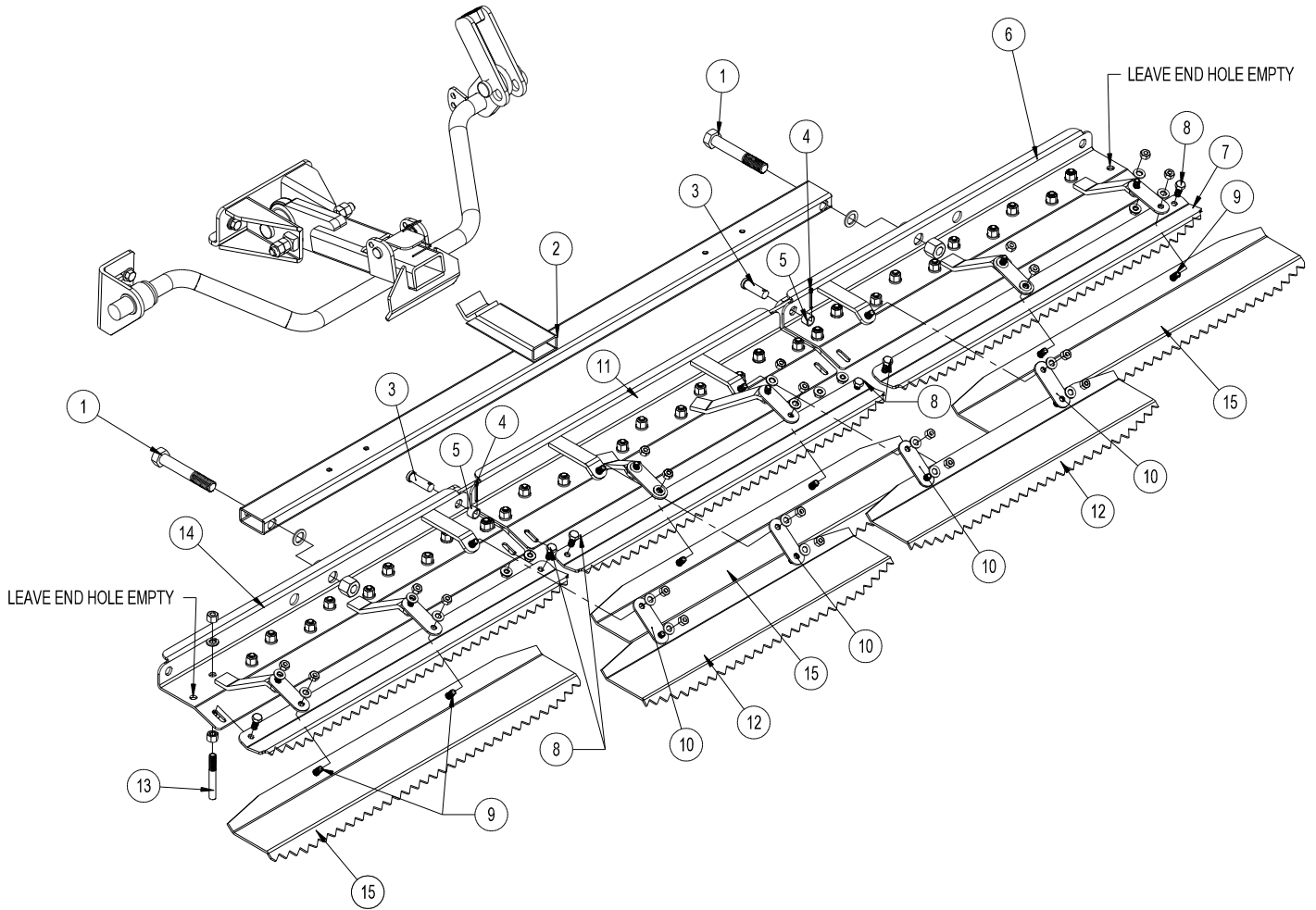

45-503 84" RAKE ASSEMBLY PARTS LIST

REF#	PART#	DESCRIPTION	QUANTITY
1*	HB-58-11-400	Hex Bolt, $\frac{5}{8}$ - 11 x 4	2
	HMB-58-14	Machine Bushing, $\frac{5}{8}$ x 14GA	2
	HNCL-58-11	Nylon Lock Nut, $\frac{5}{8}$ - 11	2
2	45-588	Draw bar	1
3*	HCP-12-150	Clevis Pin, $\frac{1}{2}$ - $1\frac{1}{2}$	2
4*	HP-18-100	Cotter Pin, $\frac{1}{8}$ x 1	2
5	76-275	Spacer	2
6	45-590	Right Rake Frame	1
7	45-586	Grooming Blade	3
8*	HB-516-18-075	Hex Bolt, $\frac{5}{16}$ - 18 x $\frac{3}{4}$	6
	HNFL-516-18	Flange Whiz-Loc Nut, $\frac{5}{16}$ - 18	6
9*	HBFL-516-18-075	Flange Whiz-Loc Bolt, $\frac{5}{16}$ - 18 x $\frac{3}{4}$	20
	HNTL-516-18	Nylon Lock Nut, $\frac{5}{16}$ - 18	20
	HW-516	Flat Washer, $\frac{5}{16}$	20
10	13-757	Rake Connect Strap	10
11	45-589	Center Rake Frame	1
12	13-443	Finishing Blade	2
13	19-106	Rake Teeth	31
	HN-38-16	Hex Nut, $\frac{3}{8}$ -16	62
	HWL-38	Lock Washer, $\frac{3}{8}$	31
14	45-591	Left Rake Frame	1
15	45-587	Finishing Blades	3
*	13-764	Hardware Kit	1

INSTALLATION INSTRUCTIONS

1. Hex Bolt rake teeth (Ref 13) to frames, keeping all the same length.
2. Lay out rake frames (Refs 6, 11 & 14). Connect them using clevis pin (Ref 3), Spacer (Ref 5) and cotter pin (Ref 4).
3. Attach left frame (Ref 14) and right frame (Ref 6) to draw bar (Ref 2) using $\frac{5}{8}$ Hex Bolt, machine bushing, and center Nylon Lock Nut (Ref 1).
4. Attach the three groomer blades (Ref 7), one to each of the rake frames (Refs 6, 11 & 14) using two Hex Bolts and Flange Whiz-Loc Nuts (Ref 8). Slide groomer blades to end of slot and tighten hardware.
5. Attach three large finishing blades (Ref 15) and then the two smaller finishing blades (Ref 12) to the tabs of the rake frames using two rake connect strap (Ref 10) per finishing blade. Secure, using flange lock Hex Bolt, flat washer and Nylon Lock Nut (Ref 9).

NOTE: Attach Straps using hardware as illustrated, placing Flat Washer on Strap then secure with Nylon Lock Nut. Attaching with the Flange Hex Bolt in contact with the Strap will cause the Strap to bind and misalign Finishing Blade.

6. Attach the rake to the trap rake quick hitch by sliding the draw bar hitch into the spring loaded locking mechanism.
7. With the rake on the ground pull the rake to the right side until it is 2-3 inches from the tire.
8. Repeat steps on left side.
9. Turn machine on and test for operation of rake assembly by raising and lowering the rake assembly. Also with rake down, turn sharp corners to check that rake does not touch wheels.
10. **NOTE:** Test rake in sand to assure tire tracks are covered by the rake when turning sharp corners in either direction. If there are tire tracks, readjust using the adjusting screws on the hitch, so the rake comes closer to the tire.



45-511 RUBBER FLEX RAKE ASSEMBLY DRAWING

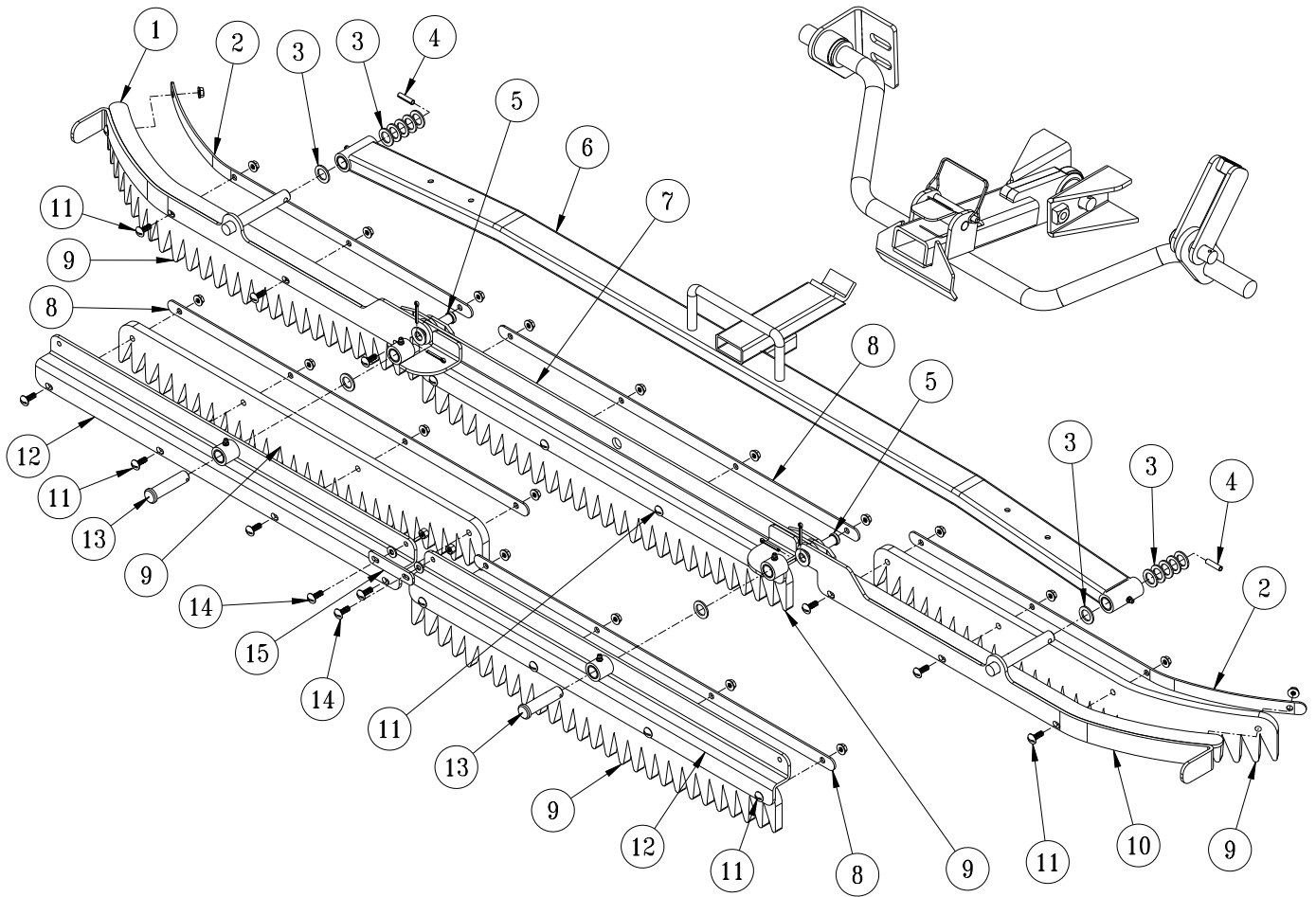

45-511 RUBBER FLEX RAKE ASSEMBLY PARTS LIST

REF#	PART#	DESCRIPTION	QUANTITY
1	45-653	LH Wing	1
2	45-657	Curved Cover Strap	2
3	HMB-58-14	Machine Bushing, $\frac{5}{8}$ x 14GA	12
4	HRP-14-100	Roll Pin, $\frac{1}{4}$ x 1	2
5	HCP-12-150	Clevis Pin, $\frac{1}{2}$ - $1\frac{1}{2}$	2
	HMB-12-14	Machine Bushing, $\frac{1}{2}$ x 14GA	2
	HP-18-100	Cotter Pin, $\frac{1}{8}$ x 1	2
6	45-649	Draw bar	1
7	45-654	Center Rake	1
8	45-658	Flat Cover Strap	1
9	45-651	Rubber Rake Blade	5
10	45-652	RH Wing	1
11	HSTP-14-20-100	Phillips Machine Screw, $\frac{1}{4}$ - 20 x 1	20
	HNFL-14-20	Flange Whiz-Loc Nut, $\frac{1}{4}$ - 20	20
12	45-655	Rear Rake Mount	2
13	HCP-58-250	Clevis Pin, $\frac{5}{8}$ x $2\frac{1}{2}$	2
	HMB-58-14	Machine Bushing, $\frac{5}{8}$ x 14GA	2
	HP-18-100	Cotter Pin, $\frac{1}{8}$ x 1	2
14	HSTP-14-20-075	Phillips Machine Screw, $\frac{1}{4}$ - 20 x $\frac{3}{4}$	2
	HNTL-14-20	Nylon Lock Nut, $\frac{1}{4}$ - 20	2
	HW-14	Flat Washer, $\frac{1}{4}$	2
15	45-656	Rake Strap	1

INSTALLATION INSTRUCTIONS

1. Hex Bolt rubber rake blades (Ref 9) onto all five rake sections using $\frac{1}{4}$ x 1 machine Hex Bolts, and Flange Whiz-Loc Nuts (Ref 11). Add cover straps (Ref 8) and then tighten hardware.
2. Lay out right, left and center rake sections and connect them using $\frac{1}{2}$ x $1\frac{1}{2}$ clevis pins, machine bushings, and cotter pins (Ref 5).
3. Attach the three assembled sections onto the draw bar (Ref 6) and secure with machine bushings and roll pins (Ref 3 and 4).
4. Connect the two rear rake mounts (Ref 12) together with the rake strap (Ref 8) using two $\frac{1}{4}$ x $\frac{3}{4}$ machine Hex Bolts with Nylon Lock Nuts (Ref 14). **Only tighten enough so they move freely.**
5. Connect the two assembled rear rake mounts onto the other rake sections using two $\frac{5}{8}$ x $2\frac{1}{2}$ clevis pins, machine bushings and cotter pins (Ref 13).
6. Attach the rake to the bunker rake quick hitch by sliding the draw bar into the spring loaded locking mechanism.
7. With the rake on the ground, pull the rake to the sides and adjust hitch stops so the rake stops about 2" from the tires.
8. Start machine and test for operation of rake assembly by raising and lowering the rake assembly. Check for loose hardware.

13-740 SAND RAKE BRUSH KIT DRAWING

For use with 42-130 and 45-511

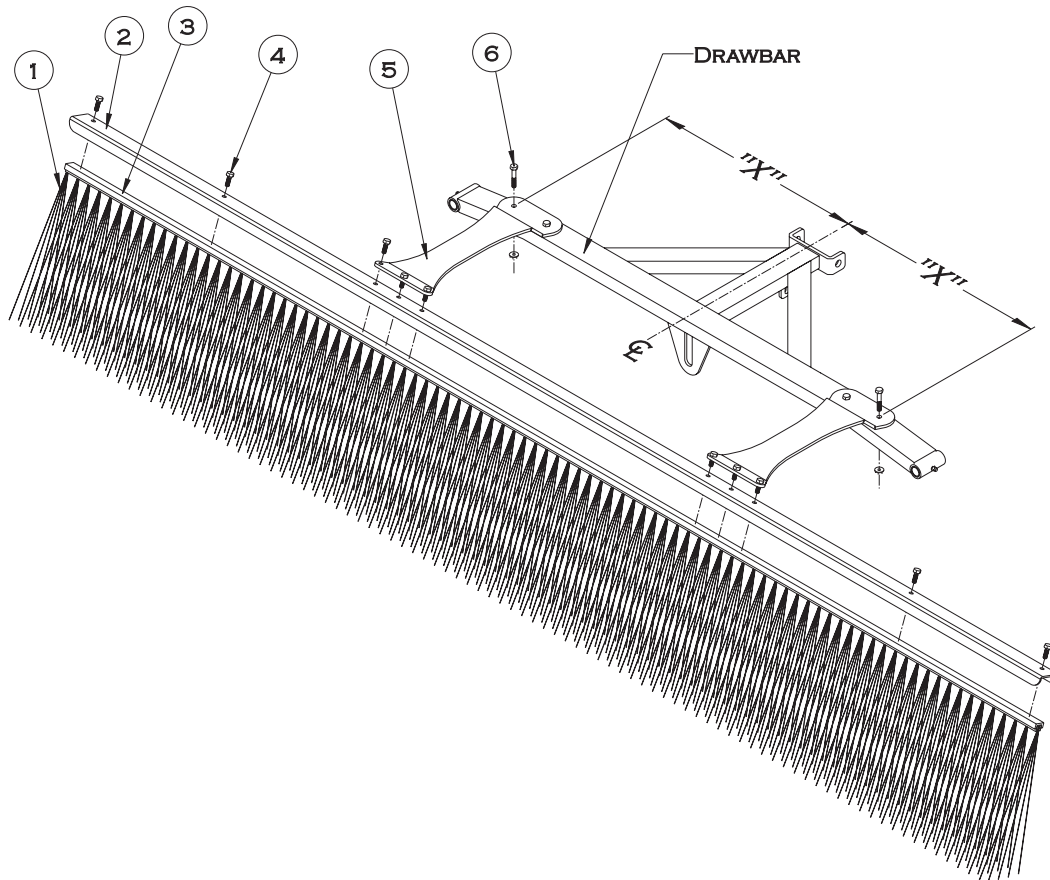

REF#	PART#	DESCRIPTION	QUANTITY
1	13-738	Brush, 89 x 11	1
2	13-737	Brush Channel	1
3	13-739	Brush Track	1
4	HB-14-20-075	Hex Bolt, 1/4 - 20 x 3/4	10
	HNFL-14-20	Flange Whiz-Loc Nut, 1/4 - 20	10
5	13-681	Mounting Brackets	2
6	HB-14-20-150	Hex Bolt, 1/4 - 20 x 1 1/2	4
	HNFL-14-20	Flange Whiz-Loc Nuts, 1/4 - 20	4

INSTALLATION INSTRUCTIONS

1. Place the Brush (Ref 1) into the Brush Track (Ref 3). Place the Brush Channel (Ref 2) between the brush track and the mounting brackets. Now Hex Bolt the Mounting Brackets (Ref 5) to the brush track using the 3/4" Hex Bolts and flange whiz-Nylon Lock Nuts(Ref 4).
2. To mount the Brush Assembly (Refs 1-5) to the Rake Draw bar, first align the Mounting Brackets so the Brush Assembly is centered ("X" measurements are equal) on the Rake Draw bar. Mark the locations for the four holes that will need to be drilled. *Note: To fit the curve of the Rake Draw bar, a small amount of twist will need to be put in the Mounting Brackets. This can be done by clamping the Mounting Brackets to the Draw bar.*
3. Mount the Brush Assembly to the Draw bar using the four 1 1/2" Hex Bolts and flange whiz-Nylon Lock Nuts(Ref 6).

13-298Q FAN RAKE ATTACHMENT DRAWING

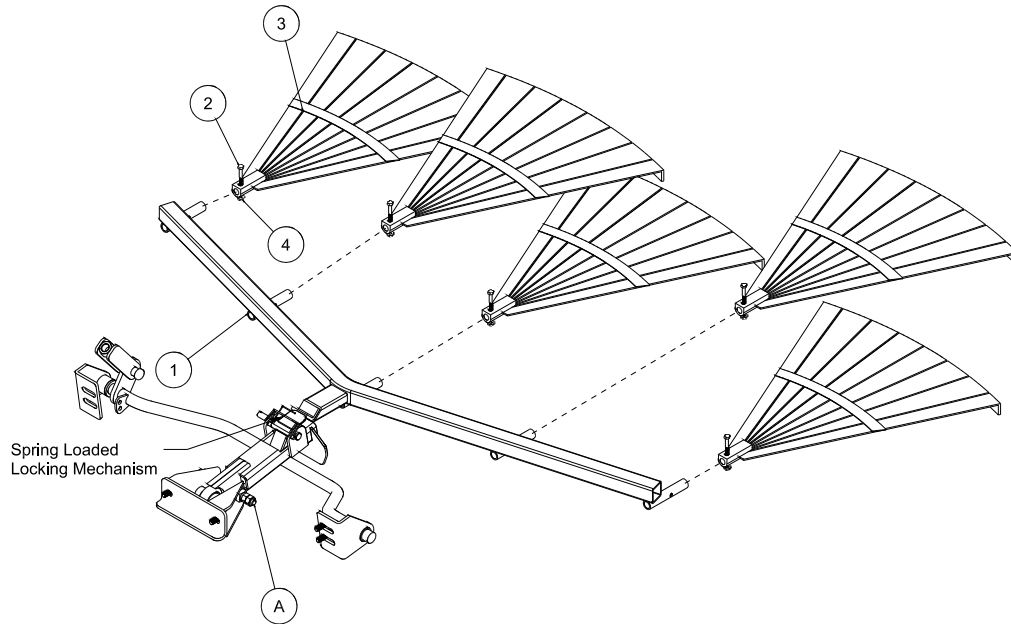

REF#	PART#	DESCRIPTION	QUANTITY
1	43-153	Frame	1
2	HB-14-20-200	Hex Bolt, 1/4 - 20 x 2	5
3	13-310	Rake	5
4	HNCL-14-20	Center Nylon Lock Nut, 1/4 - 20	5

INSTALLATION INSTRUCTIONS

1. Assemble the five rakes (Ref 3) to the frame using the Hex Bolt and center Nylon Lock Nuts (Ref 2 and 4). Slide the fan rake assembly under the rear of the trap rake to the hitch.
2. Attach the rake lift to the trap rake quick hitch, by sliding the hitch into the spring loaded locking mechanism.
3. With the rake on the ground pull the rake to the right side until it is 2-3 inches from the tire.
4. Repeat steps on left side.
5. Turn machine on and test for operation of rake assembly by raising and lowering the rake assembly. Also with rake down, turn sharp corners to check that rake does not touch wheels.

13-319-K FAN RAKE KIT DRAWING

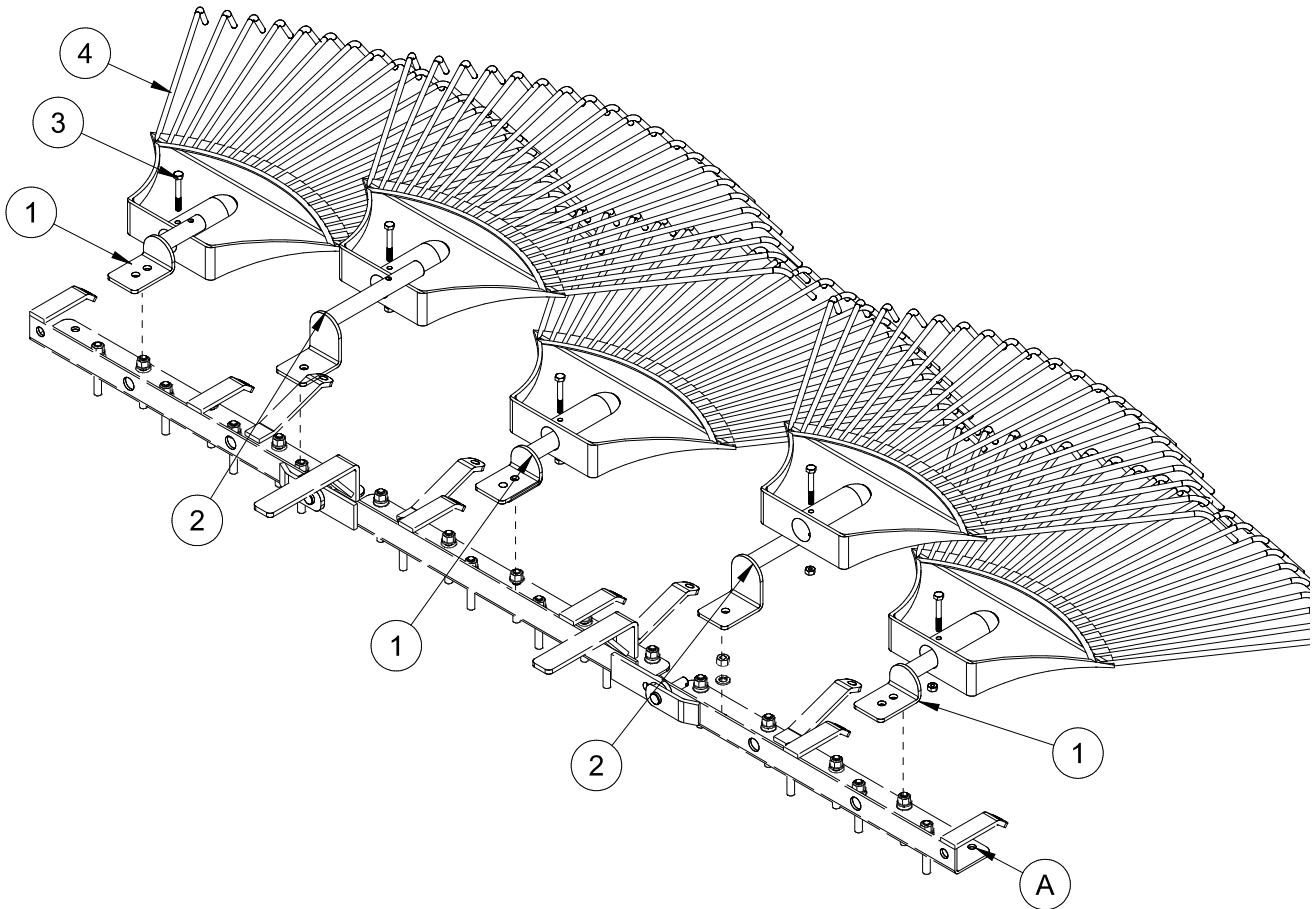

REF#	PART#	DESCRIPTION	QUANTITY
1	13-327	Holder, Universal	3
2	13-329	Long Holder	2
3	HB-14-20-200	Hex Bolt, 1/4 - 20 x 2	5
	HNTL-14-20	Nylon Lock Nut, 1/4 - 20	5
4	13-310	Fan Rake	5

A No studs in first slot - Leave Empty.

FAN RAKE KIT INSTRUCTIONS

1. Assemble the fan rakes (Ref 4) to the frame using the bolt, and lock nuts(Ref 3). Slide the fan rake assembly under the rear of the trap rake to the hitch.
2. Attach the fan rake assemblies to the top of the frame. Use the nuts and washers that are on the studs to secure in place. The outside assemblies go in the third hole from the end.
3. Turn machine on and test for operation of rake assembly by raising and lowering the rake assembly. Also, with rake down, turn sharp corners to check that rake does not touch the wheels.

26-007Q PROFESSIONAL INFIELD FINISHER DRAWING

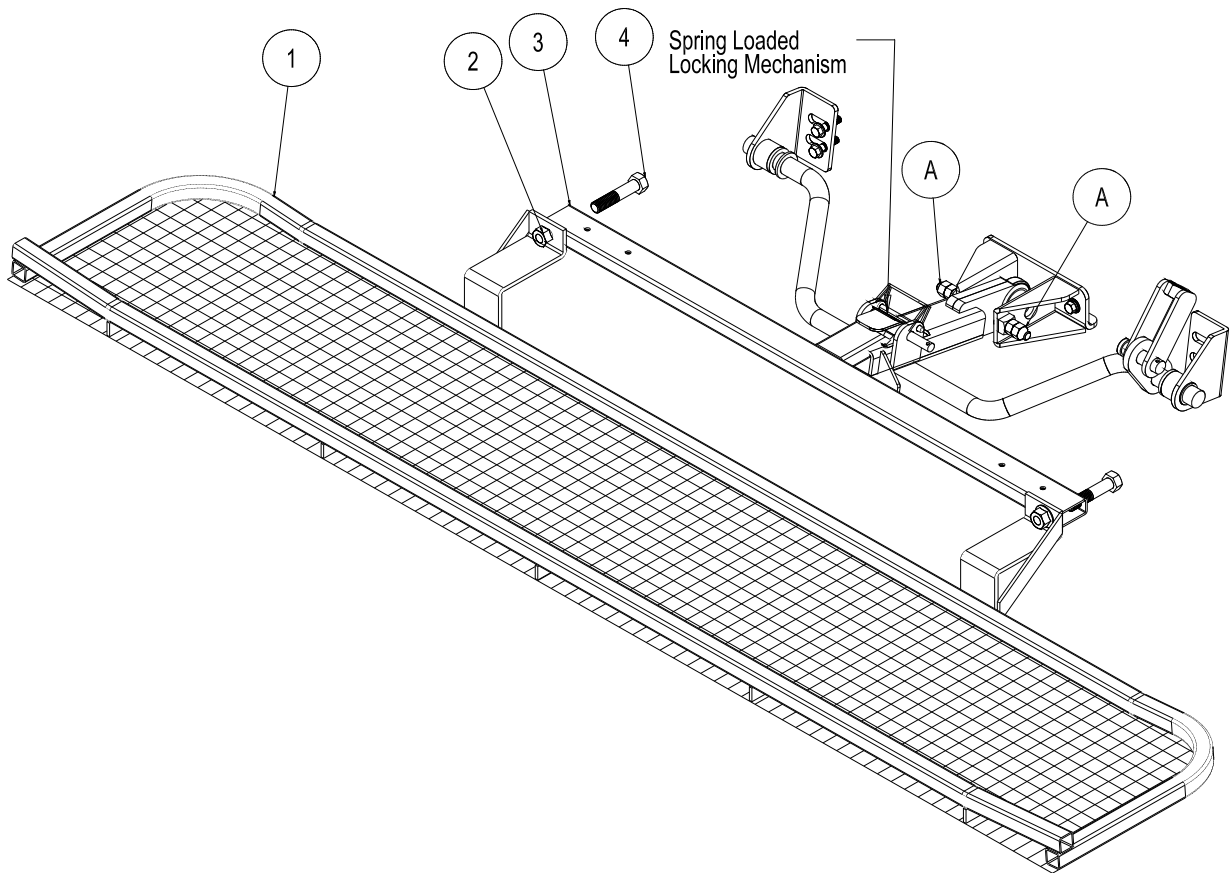

26-007Q PROFESSIONAL INFIELD FINISHER PARTS LIST

REF#	PART#	DESCRIPTION	QUANTITY
1	26-045	Leveling Screen	1
2	HNCL-58-11	Center Nylon Lock Nut, $\frac{5}{8}$ - 11	2
3	43-145	Draw bar	1
4	HB-58-11-300	Hex Bolt, $\frac{5}{8}$ - 11 x 3	2

INSTALLATION INSTRUCTIONS

The Professional Field Finisher is used for smoothing and leveling fields to professional standards.

1. Attach leveling screen (Ref 1) to draw bar (Ref 3) using two Hex Bolts (Ref 4) and center Nylon Lock Nuts (Ref 2).
2. Mount Professional Field Finisher to the hitch on the trap rake by sliding the draw bar into the quick hitch locking mechanism.
3. When Professional Field Finisher is attached, adjust Hex Bolts on hitch (Ref A) to hold Finisher in desired position.
4. **NOTE:** When assembled properly, rake will angle down from front to back. If front of finisher is not higher than the back, damage will result to infield.
5. When removing the attachment from machine. Push down on quick hitch locking mechanism and pull accessory out.

43-002Q FLEX ACTION FIELD FINISHER WITH BRUSH DRAWING

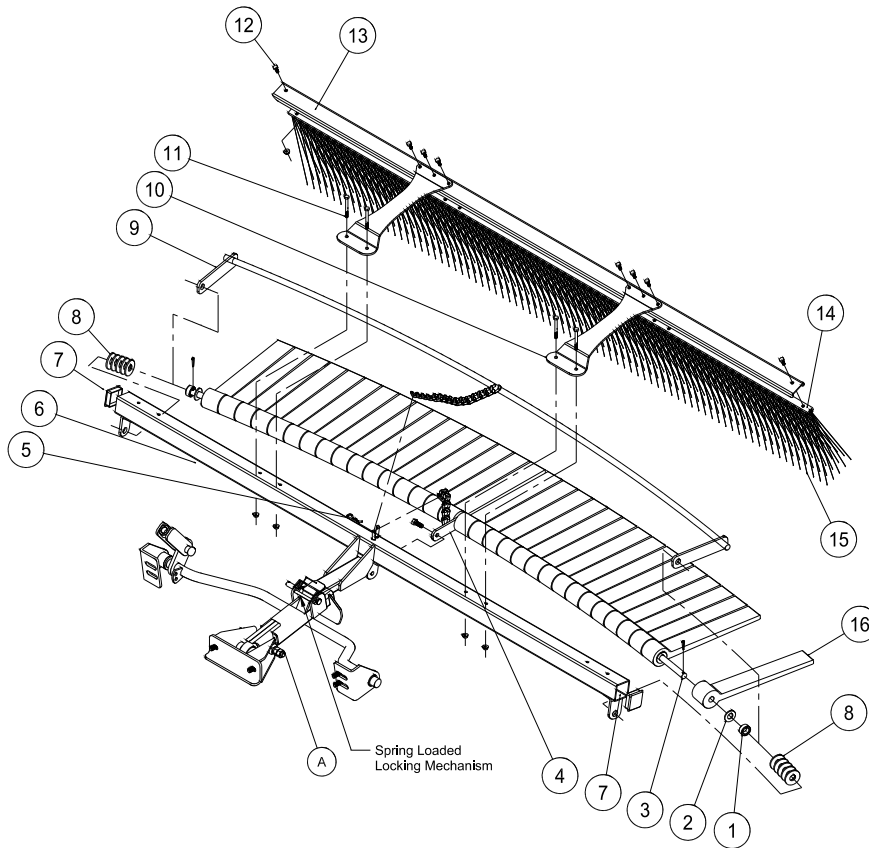

REF#	PART#	DESCRIPTION	QUANTITY
1	11-040	Spacer, $\frac{3}{4}$ "	2
2	HW-58	Washer, $\frac{5}{8}$	32
3	26-049	Mounting Bar	1
	HP-18-100	Cotter Pin, $\frac{1}{8}$ x 1	2
4	26-048	Flail Bar Strap	1
	HB-38-16-100	Hex Bolt $\frac{3}{8}$ -16 x 1	1
	HNCL-38-16	Center Nylon Lock Nut $\frac{3}{8}$ -16	1
5	HHP-18	Bridge Pin, $\frac{1}{8}$	2
6	43-146	Frame	1
7	18-297	Cap Plug	2
8	HMB-58-14	Machine Bushing $\frac{5}{8}$ x 14GA	10
9	26-047	Leveler Bar	1
10	13-681	Mount Bracket	2
11	HB-14-20-250	Hex Bolt, $\frac{1}{4}$ -20 x $2\frac{1}{2}$	4
	HNFL-14-20	Flange Whiz-Nylon Lock Nut, $\frac{1}{4}$ -20	4
12	HB-14-20-075	Hex Bolt, $\frac{1}{4}$ -20 x $\frac{3}{4}$	8
	HNFL-14-20	Flange Whiz-Nylon Lock Nut, $\frac{1}{4}$ -20	8
13	13-688	Brush Channel	1
14	13-683	Brush Track	1
15	13-682	Brush, 77 x 11	1
16	26-041	Rasp Flail	32

43-002Q FLEX ACTION FIELD FINISHER WITH BRUSH INSTRUCTIONS

ASSEMBLY INSTRUCTIONS

1. Install flail bar strap (Ref 4) to center of mounting bar (Ref 3) with chain on top of flail bar strap and mounting bar bent away from you. Apply a light coat of lubricant to overall length of mounting bar.
2. Install one rasp flail (Ref 17) with knobby side down adjacent to sides of flail bar strap. Now install a flat washer (Ref 2) so it sits adjacent with the outside of the rasp flail. Continue to install flails with knobby sides down with washers between until you have **16** flails and washers on the **left hand side** of bar strap and **17** flails and washers on the **right hand side**. Force all flails tightly toward bar strap.
3. After all 33 flails have been installed, place one spacer (Ref 1) to each end of mounting bar adjacent to washer.
4. Install leveler bar (Ref 10) to mounting bar, with curved leveler bar resting on top on the smooth sides of flails. **If all flails and washers do not fit snugly at this time, remove leveler bar and install enough machine bushings next to spacer to ensure a snug fit.** Then reinstall leveler bar.
5. Lay the frame (Ref 7) on the floor or bench with welded tabs facing up. Install ends of assembled mounting bar, with knobby sides of flails up, into welded tabs on each end of frame and secure with $\frac{1}{8}$ x 1 cotter pin.
6. Install flail bar strap (Ref 4) to center tab on frame with $\frac{3}{8}$ -16 x $1\frac{1}{2}$ Hex Bolt and $\frac{3}{8}$ -16 center Nylon Lock Nut. Loose fit is required. Do not over tighten.
7. Flip assembly over so knobby sides of flails are now facing down. Connect Finisher to the Quick Hitch frame, locking securely in the locking mechanism, as illustrated.
8. Install bar strap chain over welded pin on frame. Install leveler bar chain on to pin and secure in place with bridge pin. Use last bridge pin and clevis pin to hitch field finisher to your machine.

OPERATING INSTRUCTIONS

Running attachment with all flails down, flat on the surface, will provide a leveling function. Running attachment partially raised and flails at a 20° - 40° angle in relation to the level surface, will provide a finishing function. The flails increase down pressure for desired finish. Drive in wide circular patterns and increase or decrease ground speed to achieve desired finish.

BRUSH ASSEMBLY

1. Place the brush (Ref 16) into the brush track (Ref 15). Place the brush channel (Ref 14) between the brush track and the mounting brackets. Now Hex Bolt the mounting brackets (Ref 11) to the brush track using the $\frac{1}{4}$ - 20 x $\frac{3}{4}$ Hex Bolts and $\frac{1}{4}$ - 20 flange whiz-loc Nuts (Ref 13).
2. Mount the brush assembly to the frame using the (4) $\frac{1}{4}$ -20 x $2\frac{1}{2}$ Hex Bolts and $\frac{1}{4}$ - 20 flange whiz-loc Nuts (Ref 12).

26-008Q FLEX ACTION FIELD FINISHER DRAWING

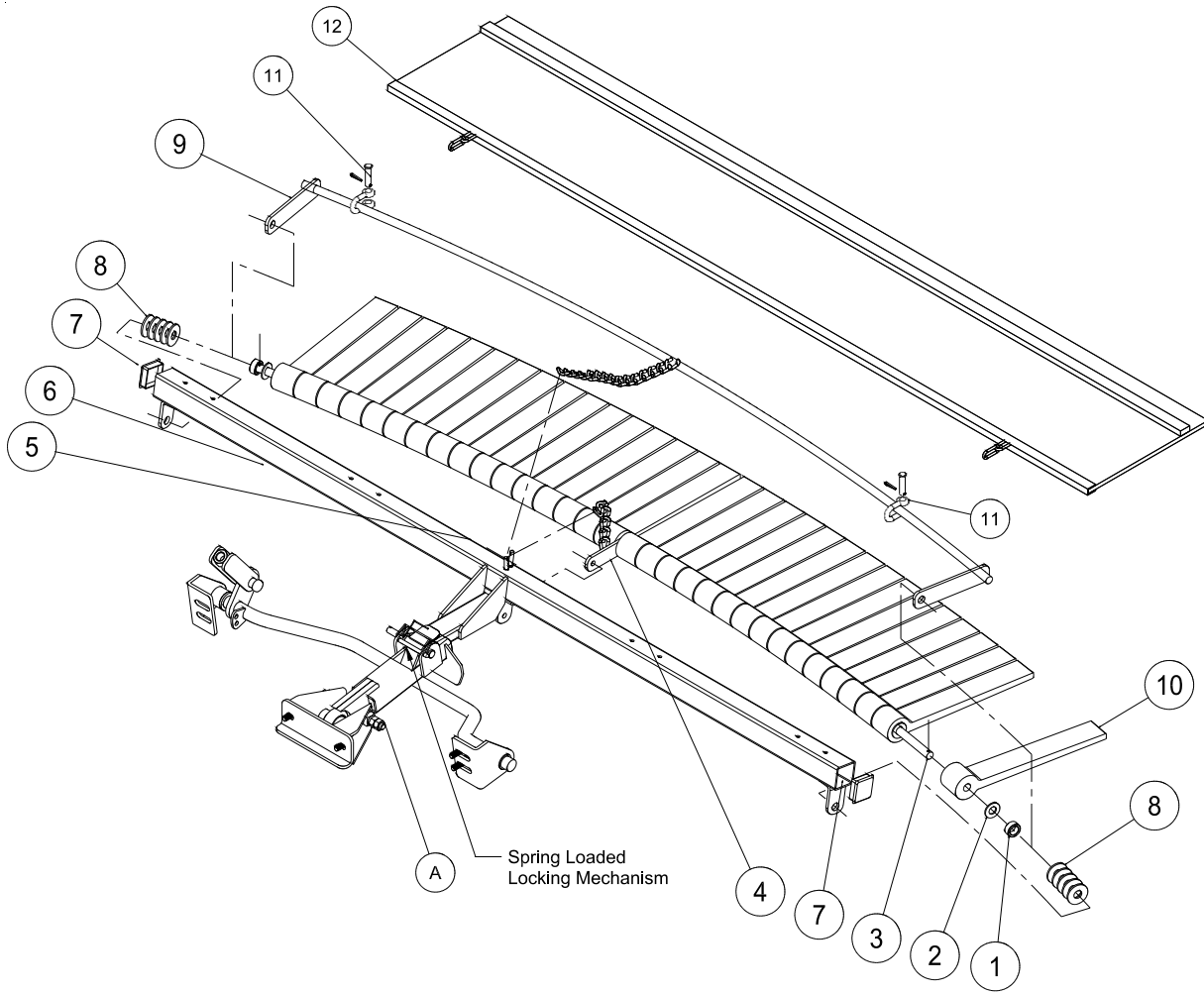

Accessories

26-008Q FLEX ACTION FIELD FINISHER PARTS LIST

REF#	PART#	DESCRIPTION	QUANTITY
1	11-040	Spacer, $\frac{3}{4}$ "	2
2	HW-58	Flat Washer, $\frac{5}{8}$	32
3	26-049	Mounting Bar	1
4	26-048	Flail Bar Strap	1
	HB-38-16-100	Hex Bolt, $\frac{3}{8}$ - 16 x 1	1
	HNCL-38-16	Center Nylon Lock Nut, $\frac{3}{8}$ - 16	1
5	HHP-18	Bridge Pin, $\frac{1}{8}$	2
6	43-146	Frame	1
7	18-297	Cap Plug	2
8	HMB-58-14	Machine Bushing, $\frac{5}{8}$ x 14GA	10
9	26-047	Leveler Bar	1
10	26-041	Rasp Flail	32
11	21-260	Clevis	2
12	26-115	Mesh Finisher	1

INSTALLATION INSTRUCTIONS

1. Install flail bar strap (Ref 4) to center of mounting bar (Ref 3) with chain on top of flail bar strap and mounting bar bent away from you. Apply a light coat of lubricant to overall length of mounting bar.
2. Install one rasp flail (Ref 16) with knobby side down adjacent to sides of flail bar strap. Now install a flat washer (Ref 2) so it sits adjacent with the outside of the rasp flail. Continue to install flails with knobby sides down with washers between until you have 16 flails and washers on each side of bar strap. Force all flails tightly toward bar strap.
3. After all 32 flails have been installed, place one spacer (Ref 1) to each end of mounting bar adjacent to washer.
4. Install leveler bar (Ref 9) to mounting bar, with curved leveler bar resting on top on the smooth sides of flails. If all flails and washers do not fit snugly at this time, remove leveler bar and install enough machine bushings to ensure a snug fit. Then reinstall leveler bar.
5. Lay the frame (Ref 6) on the floor or bench with welded tabs facing up. Install ends of assembled mounting bar, with knobby sides of flails up, into welded tabs on each end of frame and secure with $\frac{1}{8}$ x 1 cotter pin.
6. Install flail bar strap (Ref 4) to center tab on frame with $\frac{3}{8}$ -16 x 1 Hex Bolt and $\frac{3}{8}$ -16 center Nylon Lock Nut. Loose fit is required. Do not over tighten.
7. Flip assembly over so knobby sides of flails are now facing down. Install hitch to frame with clevis pin (Ref 3) and cotter pin (Ref 24). The hitch should be attached to the frame as shown.
8. Install bar strap chain over welded pin on frame. Install leveler bar chain on to pin and secure in place with bridge pin. Use last bridge pin and clevis pin to hitch field finisher to your machine.

OPERATING INSTRUCTIONS

Running attachment with all flails down, flat on the surface, will provide a leveling function. Running attachment partially raised and flails at a 20° - 40° angle in relation to the level surface, will provide a finishing function. The flails increase down pressure for desired finish. Drive in wide circular patterns and increase or decrease ground speed to achieve desired finish.

41-099 DRAG MAT DRAWING

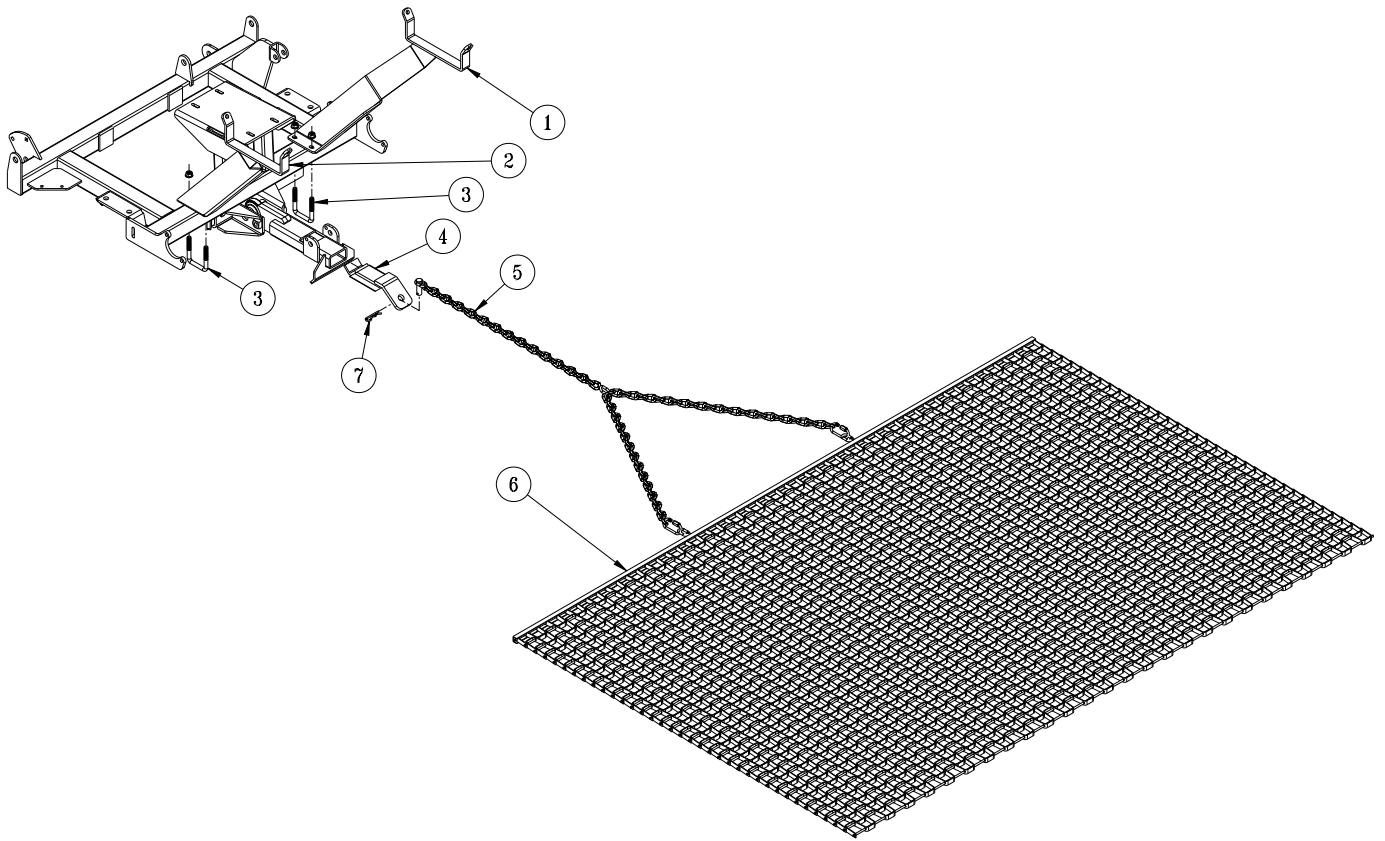

41-099 DRAG MAT PARTS LIST

REF#	PART#	DESCRIPTION	QUANTITY
1	41-097	RH Carrier Bracket	1
2	41-098	LH Carrier Bracket	1
3	17-537	Square U-Bolt	2
	HNFL-38-16	Flange Lock Nut, $\frac{3}{8}$ -16	4
4	43-143	Towing Hitch	1
5	19-605	Drag Mat Chain	1
6	19-601	Steel Drag Mat	1
7	HHP-18	Bridge Pin, $\frac{1}{8}$	1

INSTRUCTIONS

1. Install RH (Ref 1) and LH (Ref 2) Carrier Brackets using one U-Bolt and two Flange Lock Nuts (Ref 3) per Carrier Bracket. Leave loose to be able to position them.
2. Position Carrier Brackets, using the outside faces, 17" apart, centered on the rear crosstube of the mainframe. Tighten hardware.
3. Insert Towing Hitch (Ref 4) into Hitch Receiver. Place pin into Hitch hole and secure using the Bridge Pin (Ref 7).
4. For transport, roll the Drag Mat (Ref 6) and placed in the cradle of the Carrier Brackets.

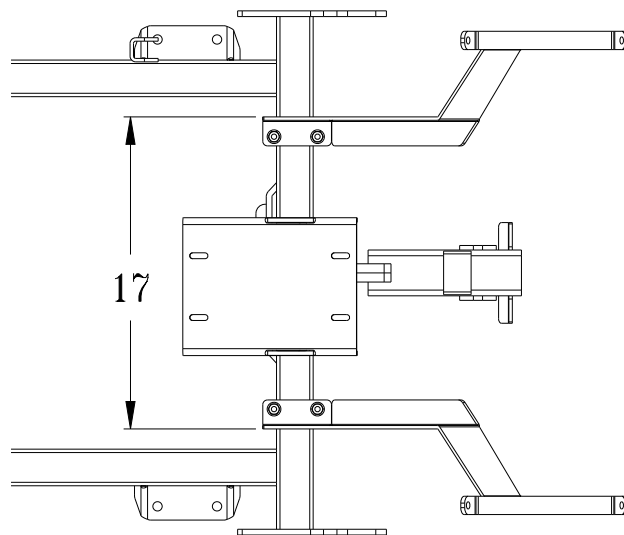

DECAL LIST

This is a list of decals located on the Sand Star. Part number, description and location will help in reordering decals.

REF#	PART#	DESCRIPTION	QTY
A	41-086	Decal, Dash Panel	1
B	27-077	Decal, Round Smithco	1
C	16-088	Decal, Warning	1
D	25-277	Decal, Battery	1
E	41-091	Decal, Sand Star	2
F	25-373	Decal, Smithco Star, Small	1
G	25-374	Decal, Smithco Star, Large	1
H	25-370	Decal, DbA 88	1
I	25-354	Decal, Tire Pressure 5PSI	3

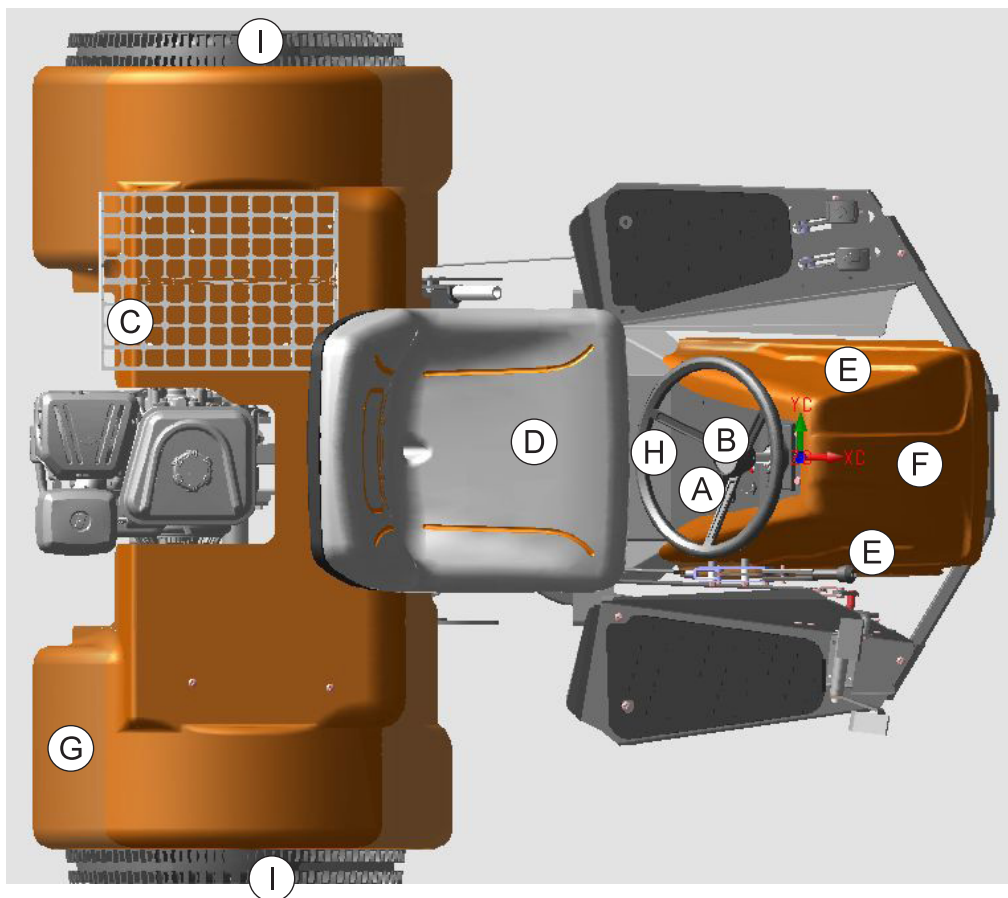

The Smithco Commercial Products Two-Year Limited Warranty

Smithco, Inc. (Smithco) warrants your 2016 or newer Smithco Commercial Product ("Product") purchased after October 1, 2016 to be free from defects in materials or workmanship for the period of time listed below. Where a warrantable condition exists, Smithco will repair the Product at no cost to you including diagnosis, labor (at the Smithco standard labor rate, subject to the Smithco flat rate schedule), and parts.

Warranty Duration is:

- (1) Two years, 1500 operational hours* from the date of delivery to the original purchaser or Five years from the date of original manufacturer of the product, whichever occurs first. (*Products equipped with hour meter).
- (2) Products used in rental situations are covered for 90 days from date of delivery to original user/renter.

Owner Responsibilities:

As the Product owner, you are responsible for required maintenance and adjustments stated in your Owner's Manual. Failure to perform required maintenance and adjustments can be grounds for disallowing a warranty claim. **You are particularly responsible to train all present and future operators of this product on the safe operation of this product at your location.**

Instructions for Obtaining Warranty Service:

You are responsible for notifying the Authorized Smithco Products Distributor from whom you purchased the Product as soon as you believe a warrantable condition exists and not later than 30 days from discovery of the condition.

If you need help locating an Authorized Smithco Distributor, or if you have questions regarding your warranty rights or responsibilities, you may contact us at:

Smithco Product Support Department
200 West Poplar Ave.
Cameron, Wisconsin 54822
Telephone: 800-891-9435 E-Mail: ProductSupport@Smithco.com

Maintenance Parts:

Parts scheduled for replacement as required maintenance ("Maintenance Parts"), are warranted for the period of time up to the scheduled replacement time for that part.

Items/Conditions Not Covered:

Not all product failures or malfunctions that occur during the warranty period are defects in materials or workmanship. The items/conditions listed below are not covered by this warranty:



Product failures which result from the use of non-Smithco replacement parts, or from installation and use of add-on, modified, or unapproved accessories are not covered.



Product failures which result from failure to perform required maintenance and/or adjustments are not covered.



Product failures that result from operating the Product in an abusive, negligent or reckless manner are not covered.



This warranty does not apply to parts subject to consumption through use, unless found to be defective. Examples of parts which are consumed, or used up, during normal Product operation include, but are not limited to: blades, tines, teeth, scarifiers, rakes, plates, wear plates, castor wheels, tires, batteries, filters, belts, nozzles, etc.



This warranty does not apply to failures caused by outside influence. Items considered to be outside influence include, but are not limited to, weather, storage practices, contamination, use of unapproved coolants, lubricants, additives, or chemicals, etc.



This warranty does not apply to normal “wear and tear” items. Normal “Wear and Tear” includes, but is not limited to, damage to seats due to wear or abrasion, worn painted surfaces, scratched decals or windows, etc.



Smithco may require the return of failed parts or components in order to determine the validity of any warranty claim.



Smithco will not be obligated to replace components of other manufacturers if inspection by the original component manufacturer indicates that failure was due to normal wear and tear, expected consumption through use or improper care or service.

Other Legal Disclaimers:

The above remedy for product defects through repair or replacement by an authorized Smithco distributor or dealer is the purchaser’s sole remedy for any defect. This warranty gives you specific legal rights, and you may also have other rights which vary from state to state.

THERE ARE NO OTHER EXPRESS WARRANTIES OTHER THAN THOSE SET FORTH ABOVE. ALL IMPLIED WARRANTIES OF MERCHANTABILITY AND FITNESS FOR USE ARE LIMITED TO THE DURATION OF THE LIMITED WARRANTIES CONTAINED HEREIN.

Some states may not allow limitations on how long an implied warranty lasts, so the above limitation may not apply to you.

THE SMITHCO COMPANY IS NOT LIABLE FOR INDIRECT, INCIDENTAL OR CONSEQUENTIAL DAMAGES IN CONNECTION WITH THE USE OF THE PRODUCT, INCLUDING ANY COST OR EXPENSE OF PROVIDING A SUBSTITUTE PRODUCT OR SERVICE DURING PERIODS OF MALFUNCTION OR NON-USE.

Some states may not allow the exclusion of indirect, incidental or consequential damages, so the above exclusion may not apply to you.

Smithco neither assumes, nor authorizes any person to assume for it, any other liability in connection with the sale or use of this product.

