

Parts & Service



SweepStar 60

76-750-A

SN: 60Q1050

January 2021

Product Support:

Hwy 55 & Poplar Ave; Cameron WI 54822

1-800-891-9435 productsupport@smithco.com

CONTENTS

Introduction

Introduction	1-3
Safe Practices	2
Specifications	3
Optional Equipment	3

Service

Service	4-9
Maintenance	4-6
Service Chart	7-8
Adjustments	9
Storage	9

Diagrams

Diagrams	10-13
Wiring Diagram	10-11
Hydraulic Diagram	12-13

Parts

Parts	14-72
Nose Cone	14
Steering Cylinder	15
Front Axle	16-17
Seat	18-19
Foot Pedal Linkage	20-21
Dash Panel	22-23
Oil Cooler and ROPs	24-25
Gas Tank and Manifold	26-27
Oil Tank	28-29
Engine and Exhaust	30-31
Reel Belt Drive	32-33
Rear Axle	34-35
Finger/Brush Reel	36-37
Hopper Lift Cylinder	38
Reel Lift Cylinder	39
Hopper	40-43
Tailgate	44
Tailgate Cylinder	45
76-638 Eaton Hydrostatic Pump	46-47
76-638 Service Information	48-58
76-539 Reel Motor	59
76-539 Service Information	60-66
76-559 Power Steering Pump	68-69
76-559 Service Information	70-72

Accessories

Accessories	74-76
76-751 Dust/Dirt Filtration Pack	74-75
76-754 French Brush Reel	76

Reference

Reference	77-78
Decal List	77
Quick Reference Replacement Parts	78

Thank you for purchasing a **Smithco** product.

Read this manual and all other manuals pertaining to the Sweep Star carefully as they contain safety, operating, assembly and maintenance instructions. Failure to do so could result in personal injury or equipment damage.

Keep manuals in a safe place after operator and maintenance personnel have read them. Right and left sides are from the operator's seat, facing forward.

 **WARNING:**

Engine exhaust and some of its constituents are known to the State of California to cause cancer, birth defects, and other reproductive harm.
For more information visit
www.P65Warning.ca.gov

WARNING

Failure to follow cautious operating practices can result in serious injury to the operator or other persons. The owner must understand these instructions, and must allow only trained persons who understand these instructions to operate this vehicle.

All **Smithco** machines have a Serial Number and Model Number. Both numbers are needed when ordering parts. The serial number plate on the Sweep Star 60 is located on the right main frame below oil tank. Refer to engine manual for placement of engine serial number.

For product and accessory information, help finding a dealer, or to register your product please contact us at <http://www.Smithco.com>.

Information needed when ordering replacement parts:

1. Model Number of machine
2. Serial Number of machine
3. Name and Part Number of part
4. Quantity of parts

For easy access record your Serial and Model numbers here.

SMITHCO WAYNE, PENNSYLVANIA 19087 USA 610-688-4009 Fax 610-688-6069			
SERIAL NO. <input type="text"/>	kW/hp <input type="text"/>	DATE OF MFG. <input type="text"/>	
MODEL NO. <input type="text"/>	lb/kg Empty <input type="text"/>	lb/kg Full <input type="text"/>	

SMITHCO CUSTOMER SERVICE 1-800-891-9435

SAFE PRACTICES

1. It is your responsibility to read this manual and all publications associated with this machine (engine, accessories and attachments).
2. Never allow anyone to operate or service the machine or its attachments without proper training and instructions. Never allow minors to operate any equipment.
3. Learn the proper use of the machine, the location and purpose of all the controls and gauges before you operate the equipment. Working with unfamiliar equipment can lead to accidents.
4. Wear all the necessary protective clothing and personal safety devices to protect your head, eyes, ears, hands and feet. Operate the machine only in daylight or in good artificial light.
5. Inspect the area where the equipment will be used. Beware of overhead obstructions and underground obstacles. Stay alert for hidden hazards.
6. Never operate equipment that is not in perfect working order or without decals, guards, shields, or other protective devices in place.
7. Never disconnect or bypass any switch.
8. Carbon monoxide in the exhaust fumes can be fatal when inhaled, never operate a machine without proper ventilation.
9. Fuel is highly flammable, handle with care.
10. Keep engine clean. Allow the engine to cool before storing and always remove the ignition key.
11. After engine has started, machine must not move. If movement is evident, the neutral mechanism is not adjusted correctly. Shut engine off and readjust so the machine does not move when in neutral position.
13. Never use your hands to search for oil leaks. Hydraulic fluid under pressure can penetrate the skin and cause serious injury.
14. This machine demands your attention. To prevent loss of control or tipping of the vehicle:
 - A. Use extra caution in backing up the vehicle. Ensure area is clear.
 - B. Do not operate on a slope greater than 10°. Pay careful attention to the inclinometer on you machine.
 - C. Do not stop or start suddenly on sloped surfaces.
 - D. Reduce speed on slopes and in all turns. Use caution when changing directions on all surfaces.
 - E. Do not change directions of travel on any slope.
 - F. Do not operate debris hopper lift or tailgate while on slopes.
 - G. Stay alert for holes in the terrain and other hidden hazards.
15. Before leaving operator's position for any reason:
 - A. Disengage all drives.
 - B. Lower all attachments to the ground.
 - C. Set park brake.
 - D. Shut engine off and remove the ignition key.
16. Keep hands, feet and clothing away from moving parts. Wait for all movement to stop before you clean, adjust or service the machine.
17. Keep the area of operation clear of all bystanders.
18. Never carry passengers.
19. Stop engine before making repairs/adjustments or checking/adding oil to the crankcase.
20. Use parts and materials supplied by SMITHCO only. Do not modify any function or part.
21. Do not remove the radiator cap when the engine is hot. When cooled, loosen cap slightly to the stop to relieve any pressure before removing the cap completely.

These machines are intended for operation by well trained persons performing professional maintenance on golf courses, sports turf, and any other area maintained turf and related trails, paths and lots. No guaranty as to the suitability for any task is expressed or implied.

SPECIFICATIONS FOR SWEEP STAR 60

WEIGHTS AND DIMENSIONS

Length	134" (340 cm)
Width	74.5" (179 cm)
Height with Hopper Down	82" (208 cm)
Height with Hopper Up	124" (315 cm)
Wheel Base	72" (183 cm)
Weight	2550 lbs (1157 kg)

ROLL OVER PROTECTION BAR WITH SEAT BELTS

Smithco Engineered Operator Structure with Seat Belts

SOUND LEVEL

At ear level	86 dB
At 3 ft (0.914 m)	88 dB
At 30 ft (9.14 m)	76 dB

ENGINE

Make	Briggs & Stratton
Model#	613477
Type / Spec#	0271-J1
Horsepower	35 Hp (26 kw)
Fuel	Unleaded 87 Octane Gasoline Minimum
Cooling System	Air Cooled
Lubrication System	Full Pressure
Alternator	24 Amp

Tire & Wheels

Front: Two 20 x 10.00 x 10 Turf-trac (18 psi; 1.3 bar)
Rear: Two 24 x 13.00 x 12 Super Soft (18 psi; 1.3 bar)
Castor: 9 x 3.5 - 4 (20 psi; 1.4 bar)

SPEED

Forward Speed	0 to 12 m.p.h. (0-19 kph)
Reverse Speed	0 to 4 m.p.h. (0-6 kph)

BATTERY

	Automotive type 24F -12 volt
BCI Group	Size 24F
Cold Cranking Amps	4600minimum
Ground Terminal Polarity	Negative (-)
Maximum Length	10.25" (26 cm)
Maximum Width	6.88" (17 cm)
Maximum Height	10.00" (25 cm)

FLUID CAPACITY

Crankcase Oil	See Engine Manual
Fuel	8 gallon (30,2 liters)
Hydraulic Fluid	25 gallon (94,6 liters)
Grade of Hydraulic Fluid	SAE 10W-40 API Service SJ or higher Motor Oil

OPTIONAL EQUIPMENT

- 76-753 60" Finger Reel Kit
- 76-752 60" Brush Reel Kit
- 76-751 Filtration Pack
- 76-754 France Brush Reel Kit
- 76-744 Decal Set For CE Certification

MAINTENANCE

LUBRICATION

Use No. 2 General Purpose Lithium Base Grease and lubricate every 100 hours. The Sweep Star 60 has 16 grease fittings.

- A. One on front steering cylinder.
- B. One on each front steering pivot.
- C. One on each end of steering tie rod.
- D. One on forward pedal.
- E. One on reverse pedal.
- F. One on hydrostatic forward and reverse relay.
- G. One on each castor wheel mount bracket.
- H. One on each pillow block bearing on end of finger reel.
- I. One on the outside of each tower.
- J. One on the center of park brake relay on rear axle.
- K. One on rod end of the tailgate cylinder.

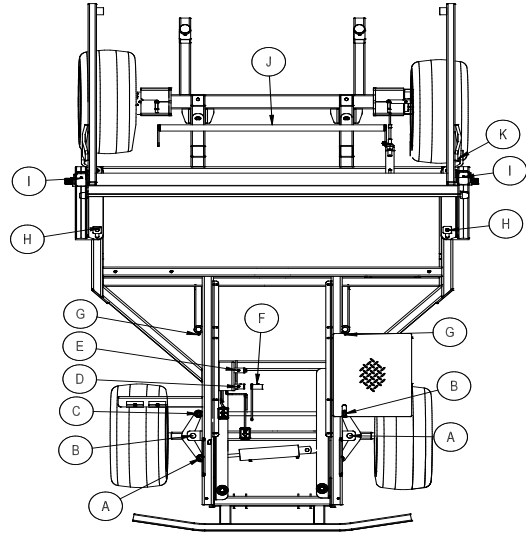

Every 500 hours of operation, separate the hydrostatic pump from the engine. Clean the splined areas and lightly grease the male portion of the pump spline. Use either Dow Corning® G-N Metal Assembly Paste or #77 Assembly Paste.

As you remount the pump to the engine, be certain the mating surface are clean and free of any foreign material and that the pump is correctly aligned.

ELECTRICAL CONNECTIONS

Use dielectric grease on all electrical connections.

AIR CLEANER ON ENGINE

1. Unclip the two clips, remove the cover and pull out the element.
2. To service, clean by tapping gently on flat surface. Do not oil. Replace if very dirty or damaged.
3. Clean out the inside of the body and cover.
4. Place the element into the body and put the cover back on..

IMPORTANT

Do not use petroleum solvents, e.g., kerosene, which will cause cartridge to deteriorate. Do not use pressurized air to clean cartridge. Pressurized air can damage cartridge.

Cyclonic air cleaner
76-395-04

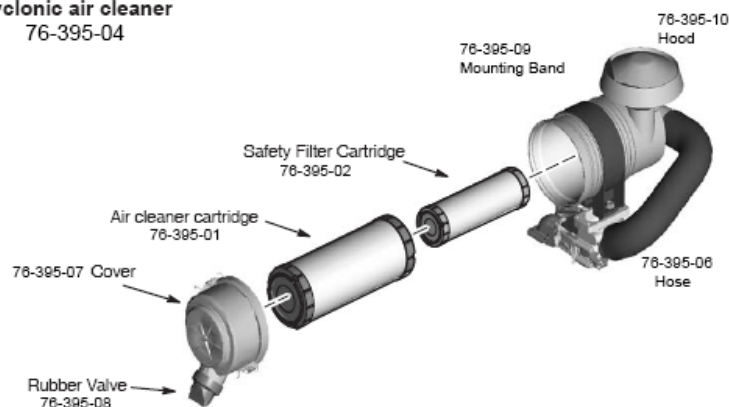

ENGINE OIL

Change and add oil according to chart below based on air temperature at the time of operation. Do not overfill. Use a high-quality detergent oil classified for service SF, SG, SH, SJ or higher. Use no special additives with recommended oils. Do not mix oil with gasoline.

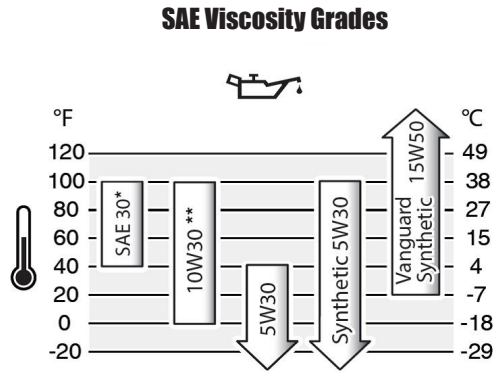

Starting Temperature Range Anticipated Before Next Oil Change

HYDRAULIC OIL

1. Use SAE 10W-40 API Service SJ or higher motor oil.
2. For proper warranty, change oil every 500 hours or annually, which ever is first and change the filter after the first 50 hours, then every 250 hours thereafter.
3. The oil level should be 2" to 2½" from top of the tank when fluid is cold. Do not overfill.
4. After changing oil and/or filter, run the machine for a few minutes. Check oil level and for leaks.
5. Always use caution when filling hydraulic oil tank or checking level to keep system free of contaminants. Check and service more frequently when operating in extremely cold, hot or dusty conditions.
6. If natural color of fluid is now black or smells burnt, it is possible that an overheating problem exists.
7. If fluid becomes milky, water contamination may be a problem.
8. If either of the above conditions happen, change oil and filter immediately after fluid is cool and find cause. Take fluid level readings when system is cold.
9. In extreme temperatures you can use straight weight oil. We recommend SAE 30W API Service SJ or higher when hot (above 90°F (33°C)) and SAE 10W API Service SJ or higher when cold (below 32°F (0°C)) ambient temperature. Use either motor oil or hydraulic oil, but do not mix.
10. Oil being added to the system must be the same as what is already in the tank. Mark tank fill area as to which type you put in.

TOWING

When it is necessary to move the Sweep Star 60 without engine running, the bypass valve built into hydrostatic pump must be "open" by turning it counterclockwise. The valve is located on bottom left of pump. An "open" valve allows fluid to pass through the wheels freely. When normal, driven, operation is desired, valve should be closed by turning it clockwise. Failure to "close" the valve with engine running means no power to wheels.

TIRE PRESSURE

Caution must be used when inflating a low tire to recommended pressure. Over inflating can cause tires to explode. Front tires should be 5 psi (.34 bar), rear tires and castor wheel should be 20 psi (1.4 bar) maximum. Improper inflation will reduce tire life considerably.

⚠ CAUTION

MAINTENANCE (CONTINUED)

WHEEL MOUNTING PROCEDURE

1. Set park brake. Turn machine off and remove key.
2. Block wheel on opposite corner
3. Loosen nuts slightly on wheel to be removed.
4. Jack up machine being careful not to damage underside of machine.
5. Remove nuts, remove wheel.
6. Place new wheel on hub lining up Hex Bolt holes.
7. Torque nuts to 64-74 ft/lb (87-100 Nm) using a cross pattern. Torque again after first 8 hours and every 200 hours thereafter.
8. Lower machine to ground and remove blocks and jack.

BATTERY

Batteries normally produce explosive gases which can cause personal injury. Do not allow flames, sparks or any ignited object to come near the battery. When charging or working near battery, always shield your eyes and always provide proper ventilation.

Battery cable should be disconnected before using "Fast Charge".

Charge battery at 15 amps for 10 minutes or 7 amps for 30 minutes. Do not exceed the recommended charging rate. If electrolyte starts boiling over, decrease charging.

Always remove grounded (-) battery clamp first and replace it last. Avoid hazards by:

1. Filling batteries in well-ventilated areas.
2. Wear eye protection and rubber gloves.
3. Avoid breathing fumes when electrolyte is added.
4. Avoid spilling or dripping electrolyte.

⚠ WARNING

Battery Electrolyte is an acidic solution and should be handled with care. If electrolyte is splashed on any part of your body, flush all contact areas immediately with liberal amounts of water. Get medical attention immediately.

⚠ WARNING

Use of booster battery and jumper cables. Particular care should be used when connecting a booster battery. Use proper polarity in order to prevent sparks.

JUMP STARTING

To jump start (negative grounded battery):

1. Shield eyes.
2. Connect ends of one cable to positive (+) terminals of each battery, first (A) then (B).
3. Connect one end of other cable to negative (-) terminal of "good" battery (C).
4. Connect other end of cable (D) to engine block on unit being started (NOT to negative (-) terminal of battery)

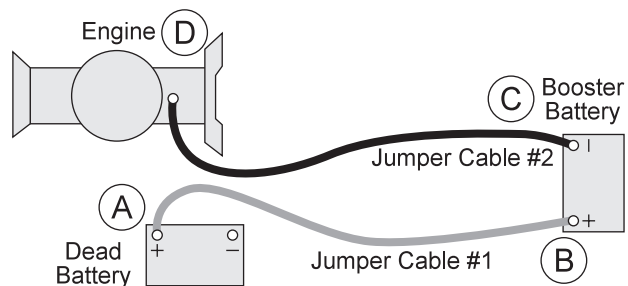

To prevent damage to other electrical components on unit being started, make certain that engine is at idle speed before disconnecting jumper cables.

SERVICE CHART

⚠ CAUTION

Before servicing or making adjustments to the machine, stop engine, set park break, block wheels and remove key from ignition.

⚠ IMPORTANT

Follow all procedures and **ONLY** use parts prescribed by the manufacturer. Read the engine manual before maintenance.

The suggested maintenance checklist is not offered as a replacement for the manufacturer's engine manual but as a supplement. You must adhere to the guidelines established by the manufacturer for warranty coverage. In adverse conditions such as dirt, mud or extreme temperatures, maintenance should be more frequent.

Maintenance Service Interval	Maintenance Procedure
After the first 8 operating hours	Torque the wheel lug nuts. (64-74 ft/lb (87-100 Nm))
	Change the engine oil filter.
Before each use daily	Check the engine oil level.
	Clean area around muffler and controls.
	Check the hydraulic fluid level.
	Check the tire pressure.
	Check and clean Debris Filter Pack1
	Check condition of hydraulic hoses and fittings.
	Inspect and clean the machine.
After the first 50 hours	Change Hydraulic Oil Filter.
Every 100 hours	Clean or change air filter.1&2
	Clean pre-cleaner.1
	Change engine oil and filter.
	Replace spark plug .
	Lubricate machine.
	Clean or change remote air cleaner.
	Check the battery fluid level and cable connections..
	Service exhaust system.
Check belt tension .	
Every 250 hours	Check engine valve clearance and adjust if necessary.
	Check idle speed.
	Clean battery terminals.
	Change hydraulic oil filter.
	Torque the wheel lug nuts. (64-74 ft/lb (87-100 Nm))
Every 500 hours or yearly	Change fuel filter.
	Change hydraulic oil and filter.
	Clean oil cooler fins.1
	Replace air filter2
	Replace fuel filter
	Clean air cooling system.1
Check safety filter in remote air cleaner.	

1 In dusty conditions or when airborne debris is present, clean more often.

2 Every third air filter change, replace the inner safety filter.

END USER SERVICE CHART

Service

Maintenance Check Item	For the week of:						
	Mon	Tues.	Wed.	Thurs.	Fri.	Sat.	Sun.
Check the Safety Seat Switch							
Check Steering Operation							
Check the fuel level							
Check the engine oil level.							
Clean the air filter							
Clean the engine cooling fins.							
Check for unusual engine noises							
Check the hydraulic oil level							
Check hydraulic hoses and fittings for damage							
Check for fluid leaks.							
Check the tire pressure							
Check the Instrumentation							
Inspect electrical system for frayed wires							
Check park brake adjustment							
Change oil filter.							
Change oil.							
Lubricate Machine							
Ensure all warning decals are intact.							
Areas of Concern							
Inspection Performed by:							
Item	Date		Information				

SWEEPING

While sweeping close tailgate frequently to ensure tailgate does not creep open.

While operating the Sweep Star's sweeper head, it is important to disengage the head before raising. If the sweeper head is raised while it is engaged, it can cause the belt to slip off the pulleys. This can result in belt failure and engine crankshaft failure. To ensure a long life of your sweeper,

CAUTION

Disengage the sweeper head before raising.

FILTER PACK

Filter pack may be cleaned by shaking or spraying off with low pressure water. Filter will disintegrate if high pressure is used on it.

PARK BRAKE ADJUSTMENT

By turning knob on end of park brake lever you can tighten or loosen brake a small amount. To tighten turn the knob clockwise. To loosen turn counter clockwise. If this is not enough turn clevis on brake cable to adjust length of cable.

WHEEL 'CREEP' ADJUSTMENT

'Creep' is when engine is running and hydrostatic transmission is in neutral, but due to inadequate alignment, wheels still move. Do the following procedures to stop this motion.

1. Lift up and support the unit so rear wheels are off the ground and can turn freely.
2. On the side of hydrostatic transmission is the shift arm (A). In the 'V' shaped notch of shift arm rests and idler pulley (B). This pulley is mounted on an idler arm (C).
3. Loosen Hex Bolt and nut holding pulley to idler arm. Leave finger tight.
4. With engine running, slide the pulley in idler arm slot until it centers on shift arm on hydrostatic and wheel 'creep' stops.
5. Tighten all fasteners and test by using foot pedal linkage to see that the 'creep' is removed.
6. Turn the engine off and lower the machine.

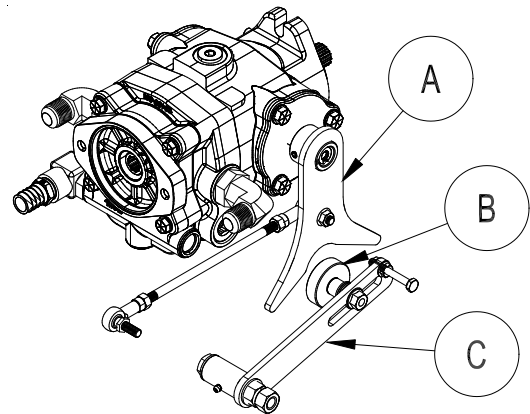

STORAGE

When storing, remove the key from the key switch to avoid unauthorized persons from operating machine.

1. Before storing clean machine thoroughly.
2. Check Hex Bolts and nuts, tighten as necessary.
3. Make all repairs that are needed and remove any debris.
4. Remove the battery, adjust the electrolyte level and recharge it. Store the battery in a dry, dark place.
5. Store in a clean and dry area, but NOT near a stove, furnace or water heater which uses a pilot light or any device that can create a spark.
6. Engines stored over 30 days need to be protected or drained of fuel to prevent gum from forming in a fuel system or on essential carburetor parts. Check the engine manual and follow the instructions for the storage of the engine.

WIRING DIAGRAM

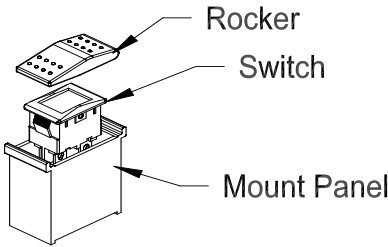

Color Code Chart	
Bl	Blue
Br	Brown
Y	Yellow
G	Green
O	Orange
R	Red
B	Black
GY	Gray
W	White

Diagrams

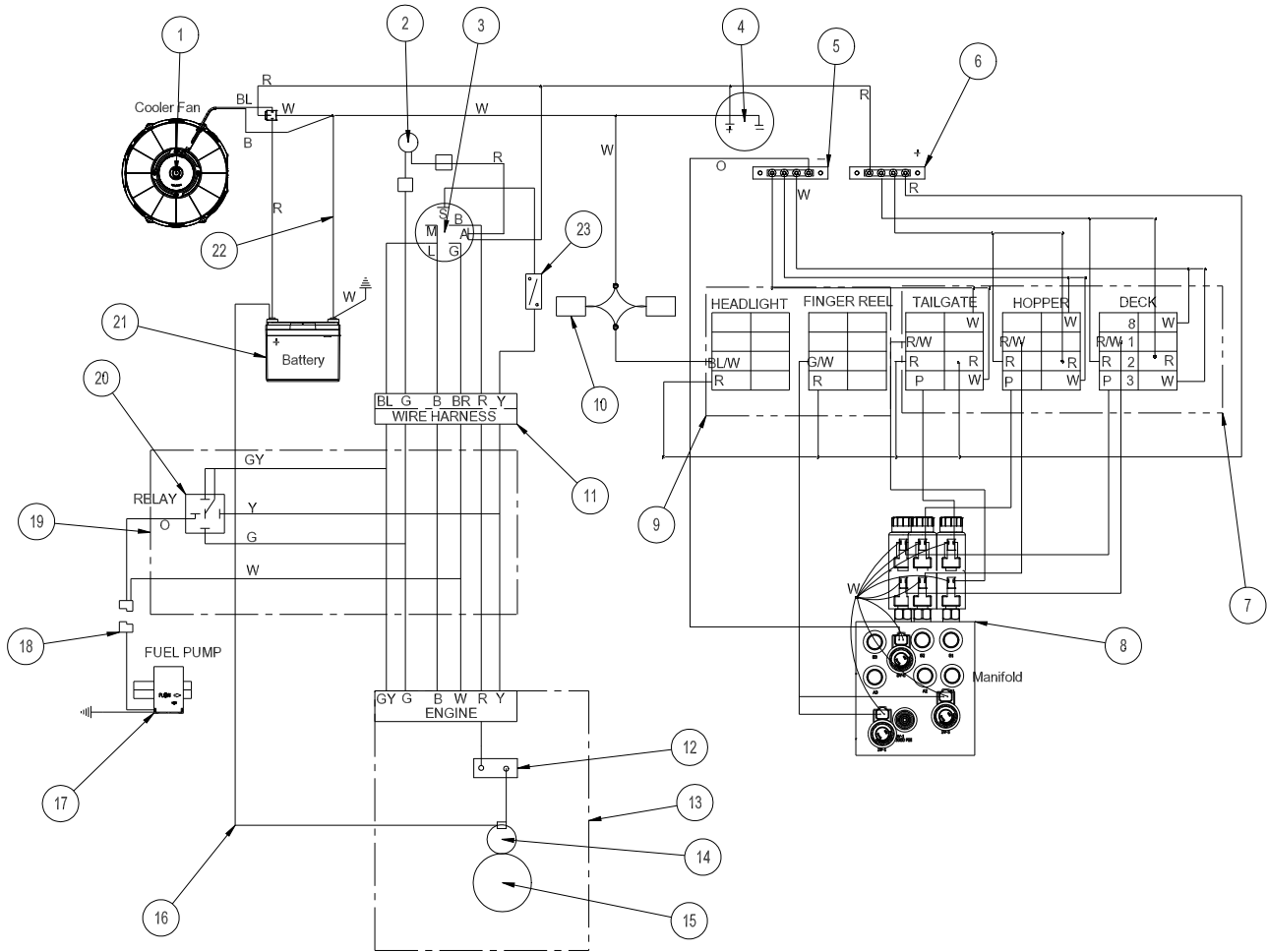

WIRING PARTS LIST

REF#	PART#	DESCRIPTION	QUANTITY
1	76-544	Cooler Fan	1
2	50-359	Warning Indicator Light	1
3	13-488	Key Switch with Hardware	1
4	12-804	Hour Meter	1
5	8935	Buss Bar - Negative	1
6	8935	Buss Bar - Positive	1
7	15-728	Centering Switch, On-Off-On	3
	15-727	Rocker, No light	3
	15-729	Mount Panel, Middle	1
	15-725	Mount Panel, End	2
8	76-560	Manifold	1
9	15-782	Unlit Switch, On-None-Off	2
	15-727	Rocker, No light	2
	15-725	Mount Panel, End	2
10	32-014	Headlights	2
11	76-563	Wire Harness	1
12	77-261	Circuit Breaker 40 AMP	1
	8977	Circuit Breaker Boot	1
13	76-484	Briggs 31hp Engine	1
14		Starter Solenoid (Part of Engine)	
15		Starter (Part of Engine)	
16	48-157	Red Battery Cable	1
17*	76-757	Electric Fuel Pump w/ Connectors	1
18*	9016	2-Contact Tower	1
	9017	Weather Pack Terminal	2
	9018	Seal	2
19	76-633	Fuel Pump Wire Harness	1
20	30-042-06	Relay	1
21	33-216	Battery	1
22	48-268	Black Battery Cable	1
23	45-529-01	Seat Switch	1
	76-563	Main Wire Harness	1
	76-633	Fuel Pump Wire Harness	1

HYDRAULIC DIAGRAM

Diagrams

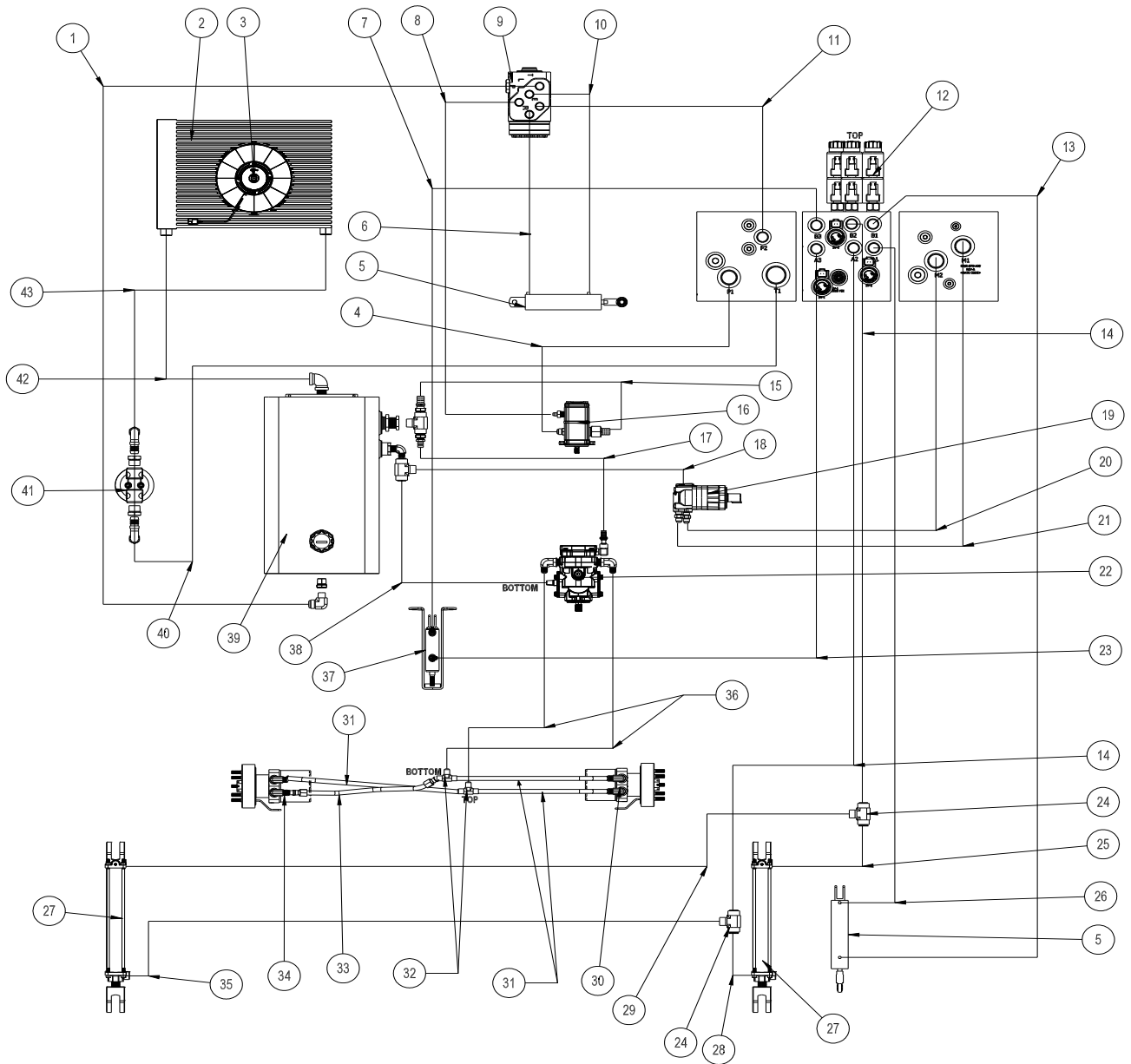

HYDRAULIC DIAGRAM PARTS LIST

REF#	PART#	DESCRIPTION	QUANTITY
1	76-532	STC Hydraulic Hose, 83"	1
2	76-561	Cooler	1
3	76-544	Cooler Fan	1
4	76-556	Hydraulic Hose, 45"	1
5	15-839	Hydraulic Cylinder (Steering & Tailgate)	2
6	76-534	STC Hydraulic Hose, 55"	1
7	76-551	Hydraulic Hose, 33"	1
8	76-535	STC Hydraulic Hose, 65"	1
9	76-559	Orbitrol	1
10	76-533	STC Hydraulic Hose, 53"	1
11	76-531	STC Hydraulic Hose, 106"	1
12	76-560	Manifold	1
13	76-557	Hydraulic Hose, 191"	1
14	76-549	Hydraulic Hose, 91"	2
15	8833-50	Suction Hose, 50"	1
	18-222	Hose Clamp	2
16	76-540	Gear Pump	1
17	8832-41	$\frac{3}{4}$ " Suction Hose, 41"	1
	18-040	Hose Clamp	2
18	76-547	Hydraulic Hose, 50"	1
19	76-539	Reel Motor	1
20	76-553	Hydraulic Hose, 48"	1
21	76-554	Hydraulic Hose, 53"	1
22	76-482	Hydrostat Pump	1
23	76-552	Hydraulic Hose, 33"	1
24	18-173	Tee $\frac{3}{8}$ " Junction Union	2
25	76-116	Hydraulic Hose, 6.5"	1
26	76-548	Hydraulic Hose, 182"	1
27	76-627	Hydraulic Cylinder (Hopper)	2
28	76-117	Hydraulic Hose, 20"	1
29	76-114	Hydraulic Hose, 72"	1
30	76-543	RH Wheel Motor	1
31	20-656	Hydraulic Tube Assembly	3
32	34-057	Tee	2
33	76-541	Hydraulic Tube Assembly	1
34	76-542	LH Wheel Motor	1
35	76-115	Hydraulic Hose, 84"	1
36	76-555	Hydraulic Hose, 116"	2
37	76-478	Hydraulic Cylinder (Reel Lift)	1
38	76-550	Hydraulic Hose, 35"	1
39	76-545	Oil Tank	1
	13-586-03	Filler Neck	1
	13-747	Filler Breather	1
40	8833-52	Suction Hose, 52"	1
	18-222	Hose Clamp	2
41	72-146	Oil Filter Assembly	1
	60-334	Filter Element (replacement only)	1
42	8833-10.5	Suction Hose, 10.5"	1
	18-222	Hose Clamp	2
43	8833-33	Suction Hose, 33"	1
	18-222	Hose Clamp	2

NOSE CONE DRAWING

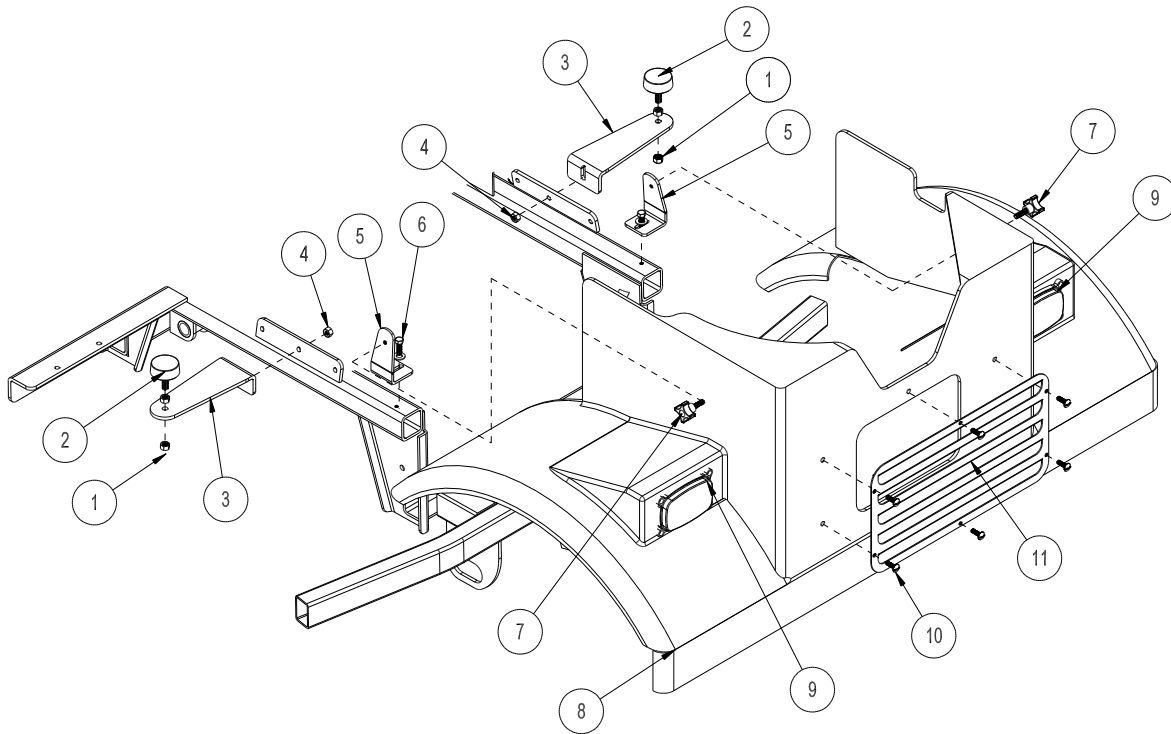

Parts

REF#	PART#	DESCRIPTION	QUANTITY
1	50-081	Rubber Insulator	2
2	HNFL-38-16	Flange Whiz-loc Nut, $\frac{3}{8}$ - 16	4
3	76-584	Glass Support	2
4	HB-516-18-100	Hex Bolt, $\frac{5}{16}$ - 18 x 1	2
	HNFL-516-18	Flange Whiz-loc Nut, $\frac{5}{16}$ - 18	2
5	76-583	Front Glass Support	2
6	HB-38-16-125	Hex Bolt, $\frac{3}{8}$ - 16 x $1\frac{1}{4}$	2
	HWL-38	Lock Washer, $\frac{3}{8}$	2
7	42-462	Plastic Knob	2
8	76-562	Nose Cone	1
9	32-014	Headlight	2
10	HSTP-14-20-075	Truss Head Screw, $\frac{1}{4}$ - 20 x $\frac{3}{4}$	6
	HNFL-1/4-20	Flange Whiz-loc Nut, $\frac{1}{4}$ - 20	6
11	76-597	Louver	1

STEERING CYLINDER DRAWING

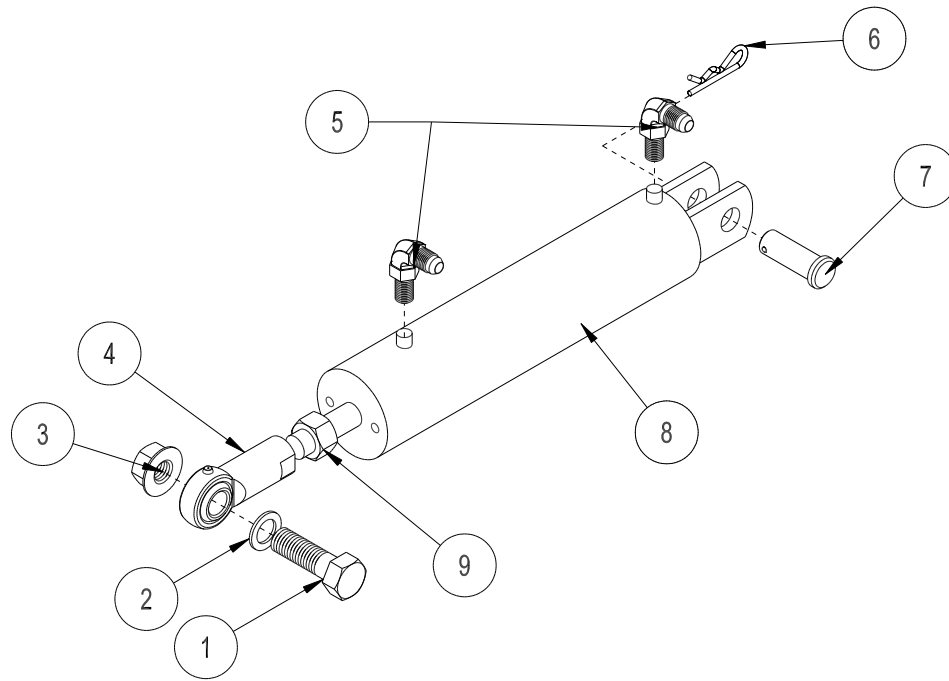

REF#	PART#	DESCRIPTION	QUANTITY
1	HB-58-11-250	Hex Bolt, $\frac{5}{8}$ - 11 x 2 $\frac{1}{2}$	1
2	HMB-58-14	Machine Bushing, $\frac{5}{8}$ - 14GA	2
3	HNTL-58-11	Nylon Lock Nut, $\frac{5}{8}$ - 11GA	1
4	18-154	Rod End	1
	HG-14-28-180	Grease Fitting, $\frac{1}{4}$ - 28 x 180°	1
5	18-168	Elbow	2
6	HHP-18	Bridge Pin, $\frac{1}{8}$	1
7	HCP-58-175	Clevis Pin, $\frac{5}{8}$ x 1 $\frac{3}{4}$	1
8	15-839	Hydraulic Cylinder	1
	15-839-01	Seal Kit	1
9	HNJ-58-18	Jam Nut, $\frac{5}{8}$ - 18	1

FRONT AXLE DRAWING

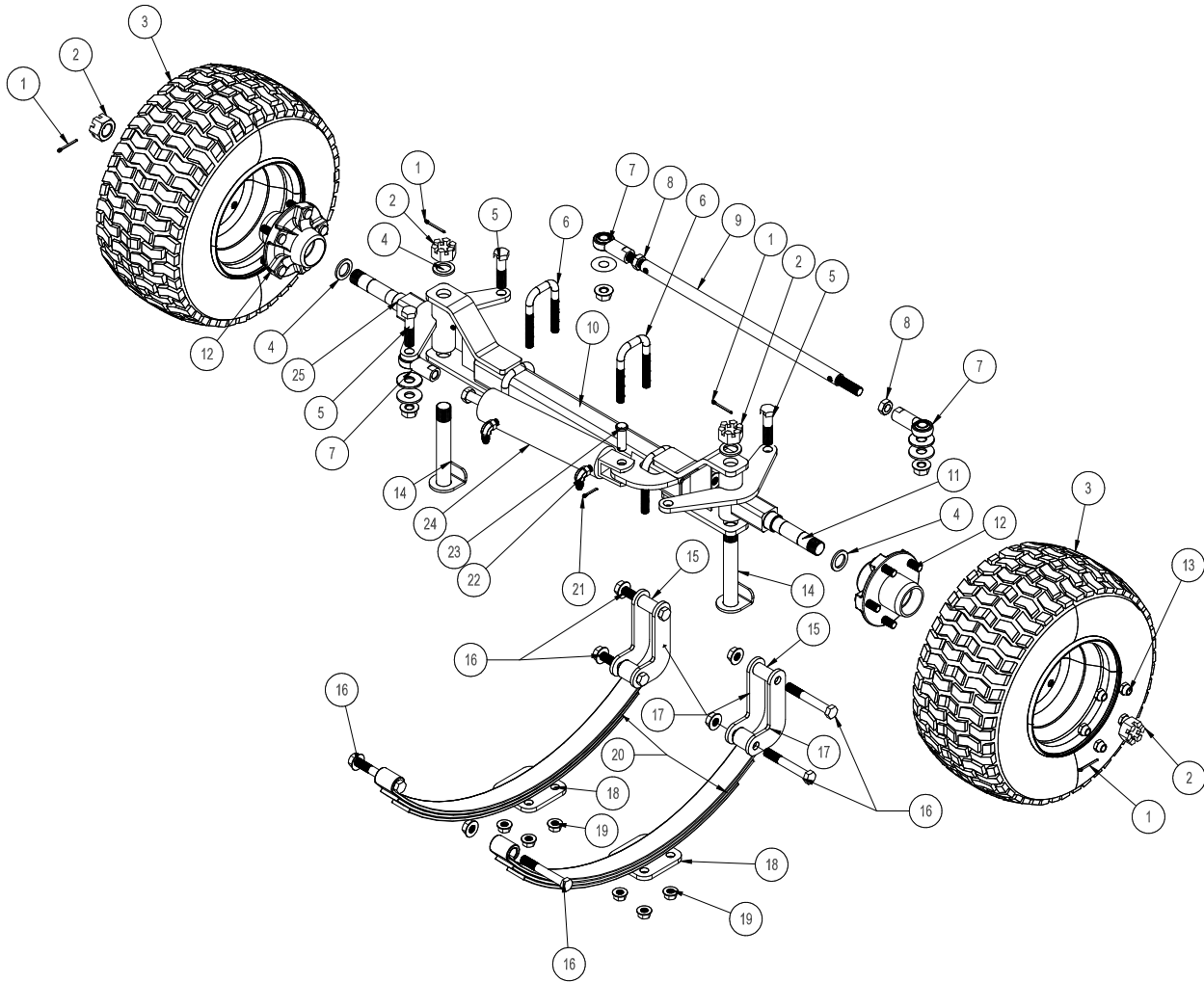

Parts

FRONT AXLE PARTS LIST

REF#	PART#	DESCRIPTION	QUANTITY
1	HP-18-150	Cotter Pin, $\frac{1}{8}$ - $1\frac{1}{2}$	4
2*	HNAR-100-14	Slotted Jam Nut, 1 -14	4
3	52-120	Front Tire and Rim	2
	52-120-01	Tire, 20 x 10.00 x 10 4-ply	2
	16-857-02	Rim	2
4	HMB-100-10	Machine Bushing, 1 x 10GA	4
5	HB-58-11-250	Hex Bolt, $\frac{5}{8}$ -11 x $2\frac{1}{2}$	3
	HMB-58-14	Machine Bushing, $\frac{5}{8}$ x 14GA	6
	HNTL-58-11	Nylon Lock Nut, $\frac{5}{8}$ - 11	3
6	20-555	U-Hex Bolt	4
7	18-154	Rod End	3
	HG-14-28-180	Grease Fitting, $\frac{1}{4}$ - 28 x 180°	3
8	HNJ-58-18	Jam Nut, $\frac{5}{8}$ - 18	3
9	76-612	Steering Linkage	1
10	76-611	Front Axle	1
11	76-610	LH Spindle	1
12*	30-071	Hub Assembly (includes * items)	2
*	11-041	Seal	2
*	11-043	Bearing	2
13*	HNL-12-20	Lug Nut, $\frac{1}{2}$ - 20	10
14	16-076	King Pin	2
15	30-251	Bushing	2
16	HB-916-18-325	Hex Bolt, $\frac{9}{16}$ - 18 x $3\frac{1}{4}$	6
	HNTL-916-18	Nylon Lock Nut, $\frac{9}{16}$ - 18	6
17	76-571	Shackle	4
18	20-538	Spring Mount	2
19	HNFL-12-13	Flange Whiz-loc Nut, $\frac{1}{2}$ - 13	8
20	20-740	Leaf Spring	2
21	HP-18-100	Cotter Pin, $\frac{1}{8}$ x 1	1
22	18-168	$\frac{3}{8}$ Straight Elbow	2
23	HCP-58-175	Clevis Pin, $\frac{5}{8}$ x $1\frac{3}{4}$	1
24	15-839	Hydraulic Cylinder	1
25	76-609	RH Spindle	1

SEAT DRAWING

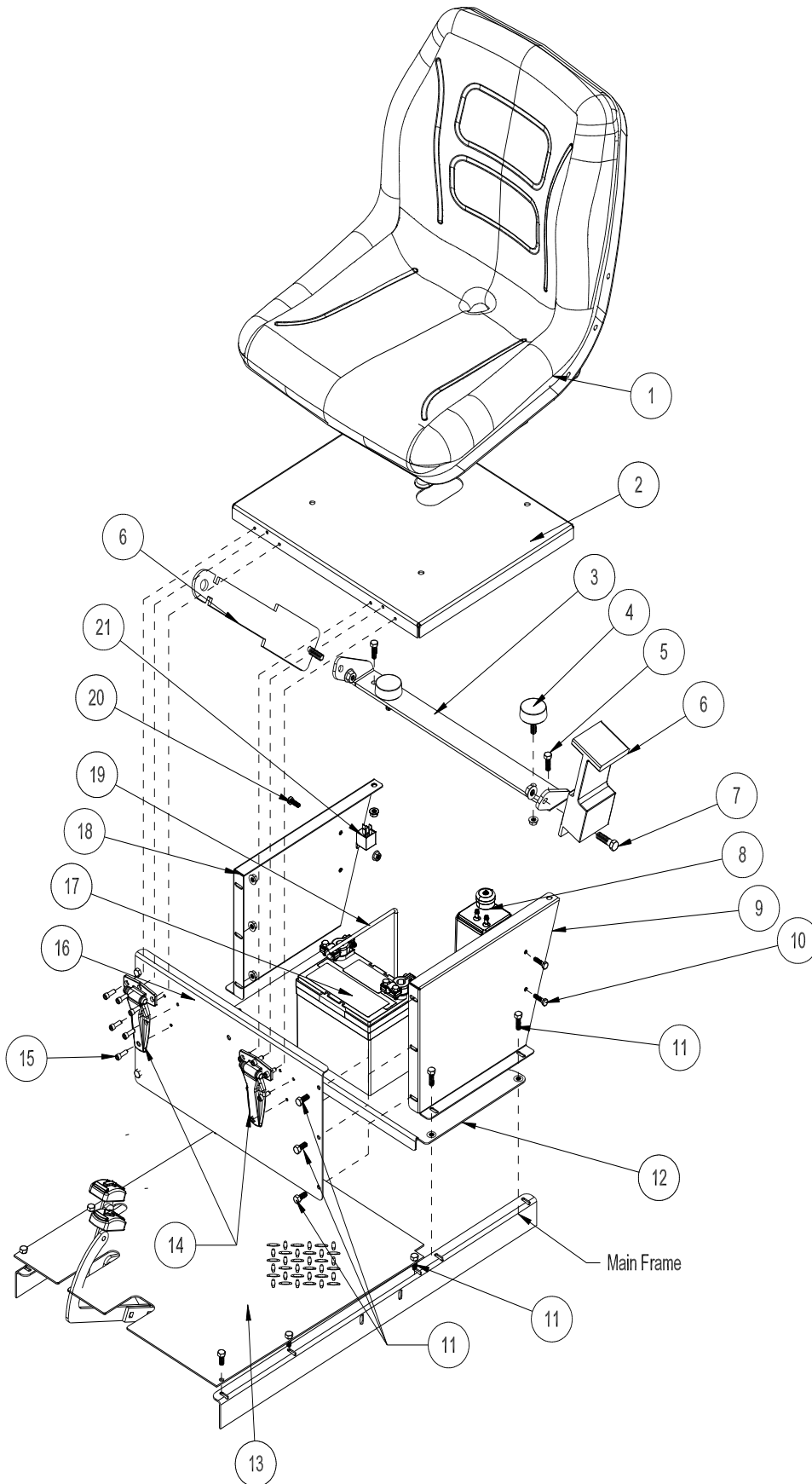

Parts

SEAT PARTS LIST

REF#	PART#	DESCRIPTION	QUANTITY
1	45-529	Seat with Suspension	1
	45-529-01	Seat Switch	1
2	76-576	Seat Panel	1
3	76-572	Bumper Support	1
4	50-081	Rubber Insulator	2
	HNFL-38-16	Flange Whiz-loc Nut, $\frac{3}{8}$ - 16	2
5	HB-516-18-100	Hex Bolt, $\frac{5}{16}$ - 18 x 1	2
	HNTL-516-18	Nylon Nylon Lock Nut, $\frac{5}{16}$ -18	2
6	76-198-03	Seat Belt	1
7	HB-716-14-100	Hex Bolt, $\frac{7}{16}$ - 14 x 1	2
	HW-38	Flat Washer, $\frac{3}{8}$	2
	HNTL-716-14	Nylon Lock Nut, $\frac{7}{16}$ - 14	2
8	8-738	Carbon Canister Assembly	1
	8-688	Carbon Canister Mount	1
9	76-587	LH Side Panel	1
10	HB-516-18-075	Hex Bolt, $\frac{5}{16}$ -18 x $\frac{3}{4}$	2
	HNFL-516-18	Nylon Lock Nut, $\frac{5}{16}$ - 18	2
11	HB-14-20-075	Hex Bolt, $\frac{1}{4}$ - 20 x $\frac{3}{4}$	16
	HW-14	Flat Washer, $\frac{1}{4}$	16
	HNFL-14-20	Flange Whiz-loc Nut, $\frac{1}{4}$ - 20	16
12	76-588	Battery Tray	1
	8803-8	Black Trim	2
13	76-600	Floorboard	1
14	27-055	Black Flush Hinge	2
15	HSMFCS-10-32-050	Flat Head Machine Screw, #10 - 32 x $\frac{1}{2}$	12
	HNFL-10-32	Flange Whiz-loc Nut, #10 - 32	12
16	76-593	Front Seat Panel	1
17	33-216	Battery	1
18	76-586	RH Side Panel	1
19	76-618	Battery Hold-down	1
	HNFL-14-20	Flange Whiz-loc Nut, $\frac{1}{4}$ -20	2
20	HSM-10-32-063	Machine Screw, #10 - 32 x $\frac{5}{8}$	1
	HNFL-10-32	Flange Whiz-loc Nut, #10 - 32	1
21	30-042-06	Relay	1

FOOT PEDAL LINKAGE DRAWING

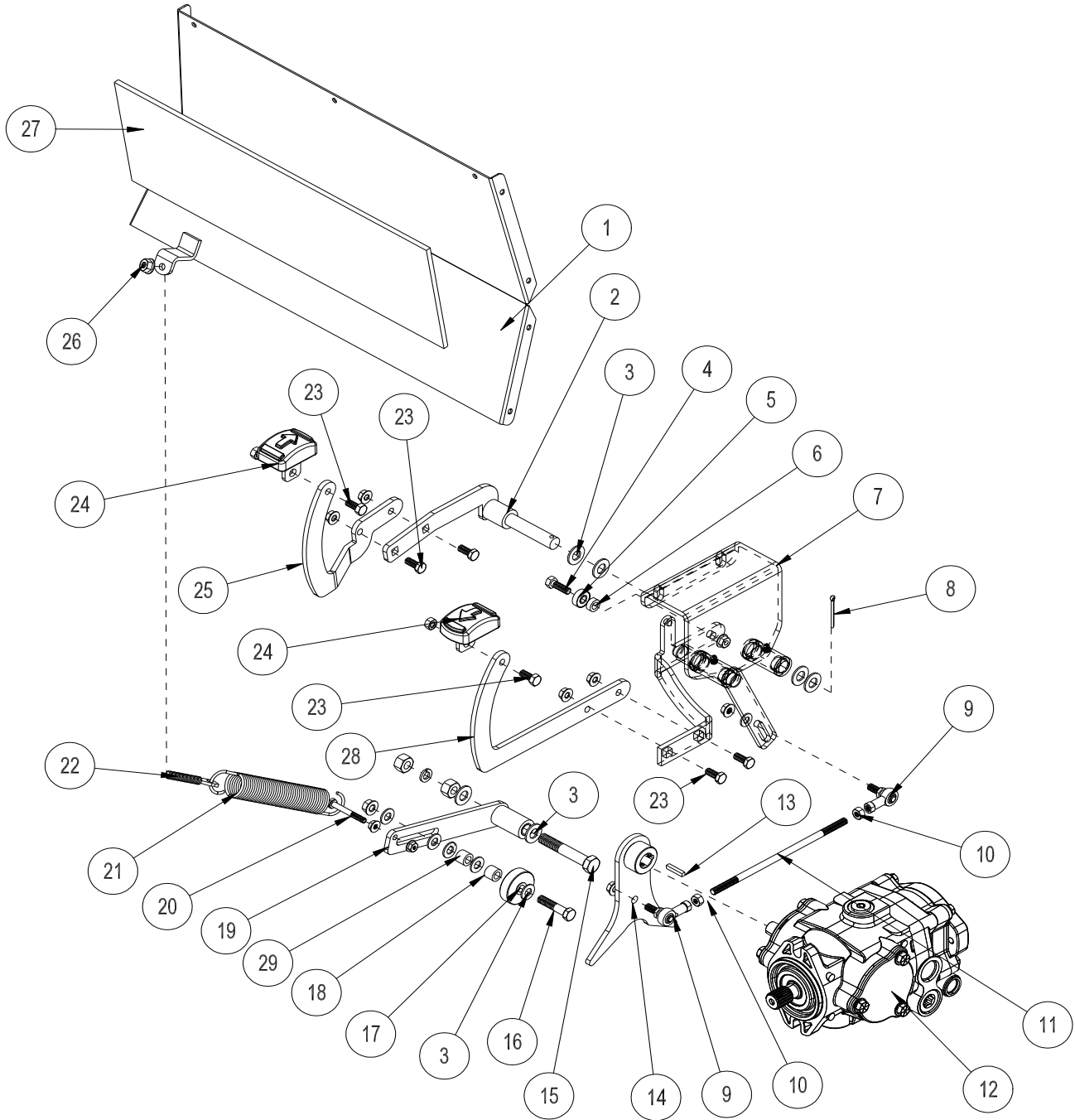

PARTS

FOOT PEDAL LINKAGE PARTS LIST

REF#	PART#	DESCRIPTION	QUANTITY
1	76-590	Firewall	1
2	76-614	Reverse Pedal Relay	1
3	HMB-12-14	Machine Bushing, 1/2 x 14GA	6
4	HB-516-18-125	Hex Bolt, 5/16 - 18 x 1 1/4	1
	HNFL-516-18	Flange Whiz-loc Nut, 5/16 - 18	1
5	8-601	Micro Ball Bearing	1
6	8-622	Spacer	1
7	76-613	Pedal Relay	1
	HG-14-28-180	Grease Fitting, 1/4 - 28 x 180°	2
8	HP-18-100	Cotter Pin, 1/8 x 1	1
9	18-441	Ball Joint, 5/16 - 24	2
10	HN-516-24	Hex Nut, 5/16 - 24	4
11	43-220	Speed Boss Link	1
12	76-638	Hydrostatic Pump	1
13	HKSQ-14-150	Square Key, 1/4 x 1 1/2	1
14	76-607	Swash Arm	1
15	HB-12-13-300	Hex Bolt, 1/2 - 13 x 3	1
	HWL-12	Lock Washer, 1/2	1
	HNTL-12-13	Nylon Lock Nut, 1/2 - 13	1
16	HB-38-16-175	Hex Bolt, 3/8 - 16 x 1 3/4	1
	HW-38	Flat Washer, 3/8	5
	HNTL-38-16	Nylon Lock Nut, 3/8 - 16	1
17	14-266	Ball Bearing	1
18	18-270	Oilite Bushing	1
19	76-606	Idler Arm	1
	HG-14-28-180	Grease Fitting, 1/4 - 28 x 180°	1
20	HB-14-20-200	Hex Bolt, 1/4 - 20 x 2	1
	HNFL-14-20	Flange Whiz-loc Nut, 1/4 -20	2
21	21-445	Spring	1
22	42-537	Spade Hex Bolt, 3/8	1
23	HBCL-516-18-075	Low Shoulder Carriage Hex Bolt, 5/16 - 18 x 3/4	6
	HNFL-516-18	Flange Whiz-loc Nut, 5/16 - 18	6
24	45-022	Molded Foot Pedal	2
25	76-566	Reverse Pedal Arm	1
26	HNTL-38-16	Nylon Lock Nut, 3/8 - 16	1
27	9023	Ceramic Mat, 7" x 20"	140 in ²
28	76-565	Forward Pedal Arm	1
29	10-134	Spacer	1

DASH PANEL DRAWING

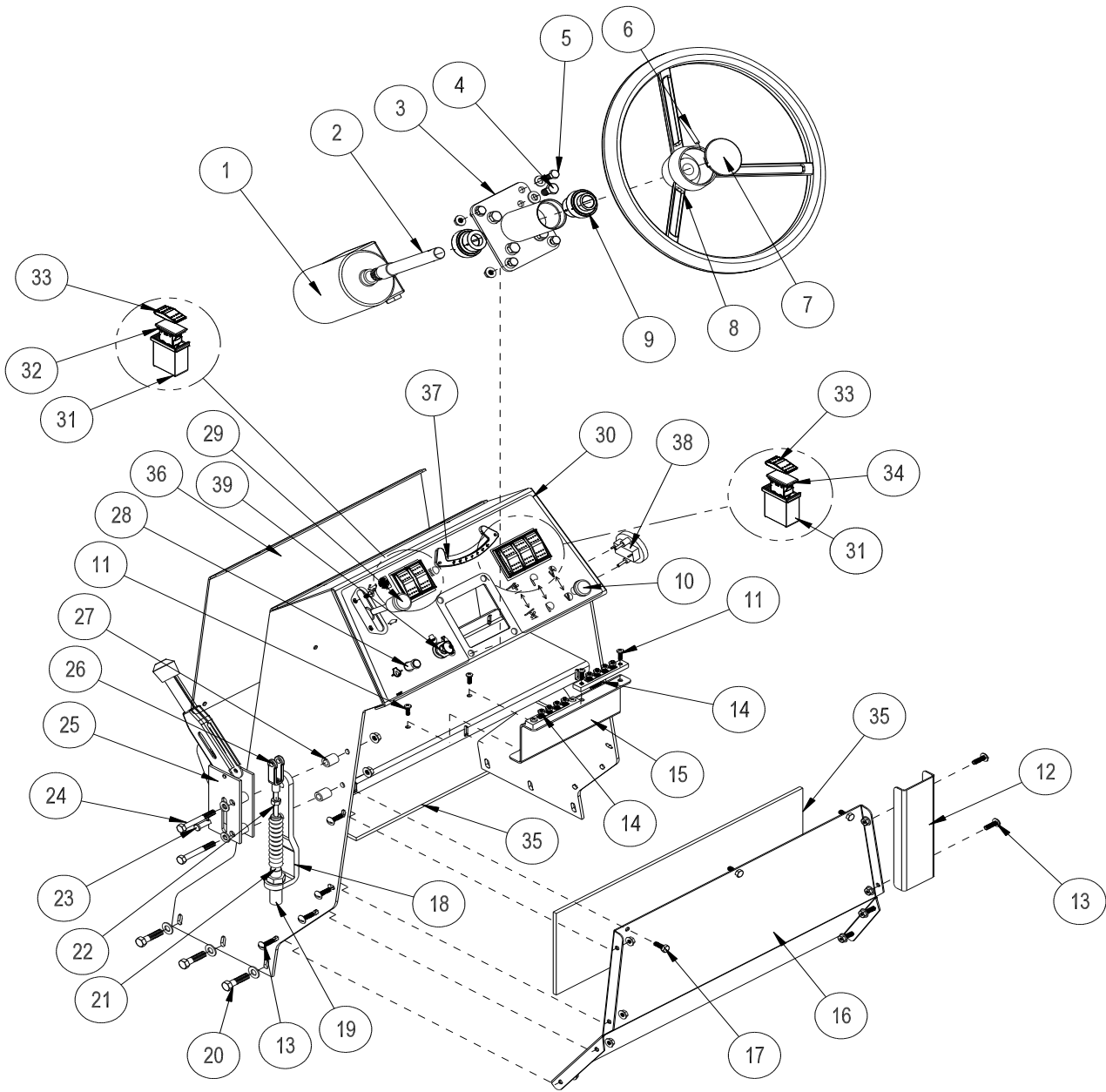

Parts

DASH PANEL PARTS LIST

REF#	PART#	DESCRIPTION	QUANTITY
1	76-559	Orbitrol	1
2	76-529	Splined Shaft	1
3	76-530	Steering Column	1
4	HBM-10-1.5-20	Metric Hex Bolt, #10 - 1.5 x 20	4
	HWLM-10	Metric Lock Washer, #10	4
5	HB-516-18-100	Hex Bolt, $\frac{5}{16}$ - 18 x 1	4
	HNFL-516-18	Flange Whiz-loc Nut, $\frac{5}{16}$ - 18	4
6	HRP-14-150	Roll Pin, $\frac{1}{4}$ x $1\frac{1}{2}$	1
7	20-129	Center Cap	1
8	20-057	15" Steering Wheel	1
9	45-155	Flange Bearing	2
10	11-086	Choke Cable	1
11	HSM-10-32-063	Machine Screw, #10 - 32 x $\frac{5}{8}$	6
	HNFL-10-32	Flange Whiz-loc Nut, #10 - 32	6
12	76-568	Wire Channel	1
13	HSTP-14-20-075	Truss Head Hex Bolt, $\frac{1}{4}$ - 20 x $\frac{3}{4}$	8
	HNFL-14-20	Nylon Lock Nut, $\frac{1}{4}$ - 20	8
14	8935	Buss Bar	2
15	76-596	Buss Bar Mount	1
16	76-590	Firewall	1
17	HB-14-20-075	Hex Bolt, $\frac{1}{4}$ - 20 x $\frac{3}{4}$	3
	HNFL-14-20	Flange Whiz-loc Nut, $\frac{1}{4}$ - 20	3
18	45-605	Park Brake Bracket	1
19	76-225	Brake Cable	1
20	HB-516-18-125	Hex Bolt, $\frac{5}{16}$ - 18 x $1\frac{1}{4}$	6
	HW-516	FLat Washer, $\frac{5}{16}$	6
	HNTL-516-18	Nylon Lock Nut, $\frac{5}{16}$ - 18	6
21	60-536	Bellow	1
22	HN-516-24	Nut, $\frac{5}{16}$ - 24	1
23	HCP-516-100	Clevis Pin, $\frac{5}{16}$ x 1	1
	HP-18-100	Cotter Pin, 1/8 x 1	1
24	HB-516-18-250	Hex Bolt, $\frac{5}{16}$ - 18 x $2\frac{1}{2}$	2
	HNTL-516-18	Nylon Lock Nut, $\frac{5}{16}$ - 18	2
25	60-106	Brake Lever w/ Kit	1
26	11-100	Yoke	1
27	10-134	Spacer	2
28	50-539	Warning Indicator Light	1
29	45-118	Throttle Cable	1
	HSM-10-32-063	Machine Screw, #10 - 32 x $\frac{5}{8}$	2
	HNFL-10-32	Flange Whiz-loc Nut, #10 - 32	2
30	76-615	Dash Console	1
	76-536	Decal, Dash Panel	1
31	15-725	Mount Panel, End	4
	15-729	Mount Panel, Middle	1
32	15-782	Unlit Switch, On-none-On	2
33	15-727	Rocker, Unlit	5
34	15-728	Centering Switch, On-Off-On	3
35	9023	Ceramic Foil (7" x 20")	2 per (140 in ²)
36	76-589	Dash Panel Back Plate	1
37	76-372	Inclinometer	1
38	12-804	Hour Meter	1
39	13-488	Ignition Switch	1

OIL COOLER AND ROPS DRAWING

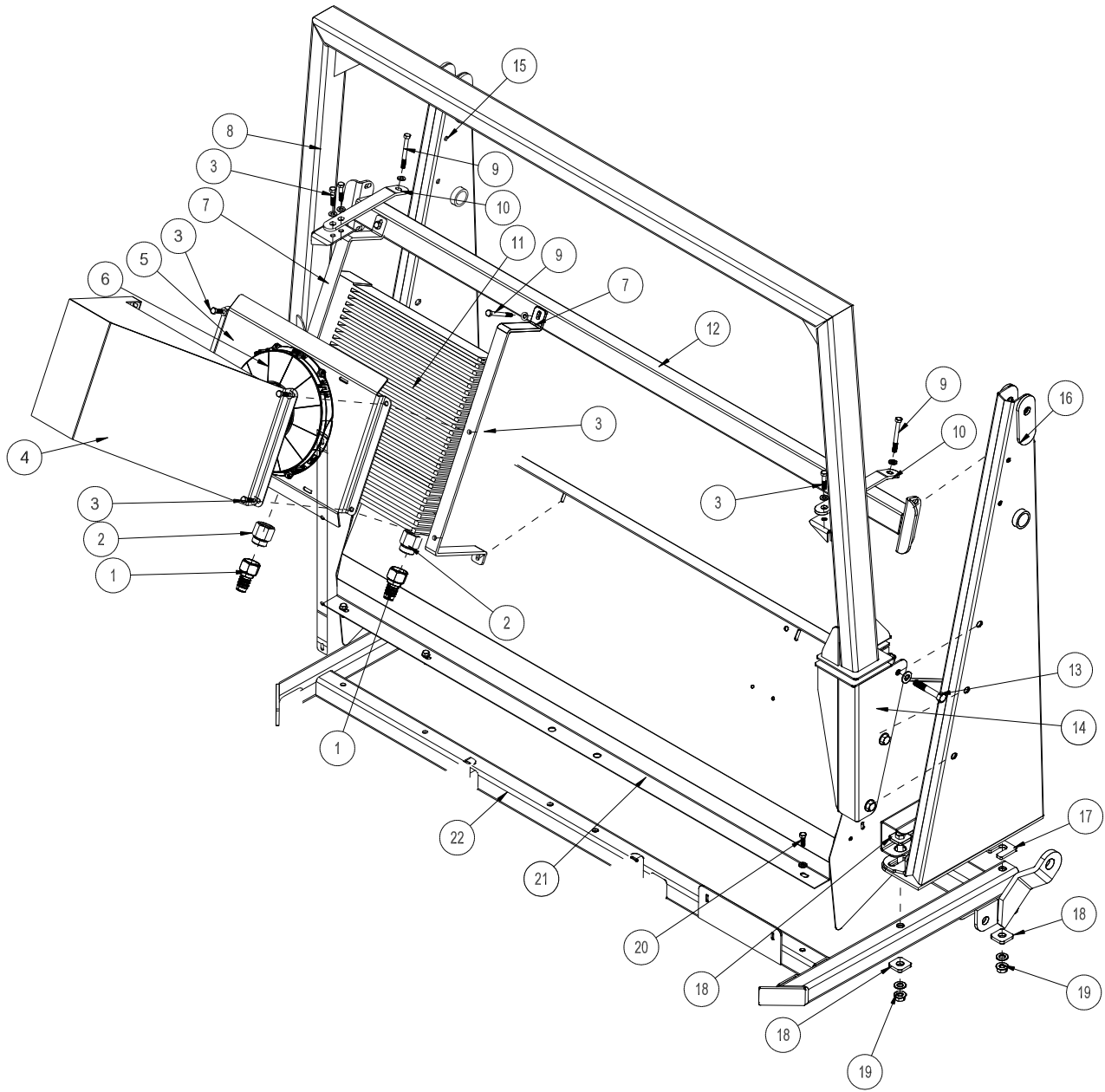

Parts

OIL COOLER AND ROPS PARTS LIST

REF#	PART#	DESCRIPTION	QUANTITY
1	18-469	Swivel Hose Barb	2
2	18-468	Straight Thread Connector	2
3	HB-516-18-150	Hex Bolt, $\frac{5}{16}$ - 18 x $1\frac{1}{2}$	8
	HW-516	Flat Washer, $\frac{5}{16}$	8
	HNTL-516	Nylon Lock Nut, $\frac{5}{16}$ - 18	8
4	76-631	Deflector	1
5	76-575	Cooler Fan Mount	1
	8803-17	Black Trim, 17"	2
6	76-544	Fan	1
7	76-573	Cooler Strap	2
8	76-381	ROP Bar	1
9	HB-516-18-300	Hex Bolt, $\frac{5}{16}$ - 18 x 3	6
	HW-516	Flat Washer, $\frac{5}{16}$	6
	HNTL-516-18	Nylon Lock Nut, $\frac{5}{16}$ - 18	6
10	76-376	Strap	2
11	76-561	Oil Cooler	1
12	75-570	Cross Bar	1
13	HB-12-13-300	Hex Bolt, $\frac{1}{2}$ - 13 x 3	6
	HW-12	Washer, $\frac{1}{2}$	6
	HNTL-12-13	Nylon Lock Nut, $\frac{1}{2}$ -13	6
14	76-380	LH ROP Support - Shown	1
	76-379	RH ROP Support	1
15	75-629	LH Tower	1
16	75-561	RH Tower	1
17	75-703	Tower Spacer	2
18	76-151	Tower Washer	8
19	HB-12-13-400	Hex Bolt, $\frac{1}{2}$ - 13 x 4	4
	HMB-12-14	Machine Bushing, $\frac{1}{2}$ x 14GA	4
	HNTL-12-13	Nylon Lock Nut, $\frac{1}{2}$ -13	4
20	HB-516-18-100	Hex Bolt, $\frac{5}{16}$ - 18 x 1	3
	HW-516	Flat Washer, $\frac{5}{16}$	3
21	76-235	Grass Chute Frame	1
	8803-60	Black Trim, 60"	1
22	76-617	Main Frame	1

GAS TANK AND MANIFOLD DRAWING

Parts

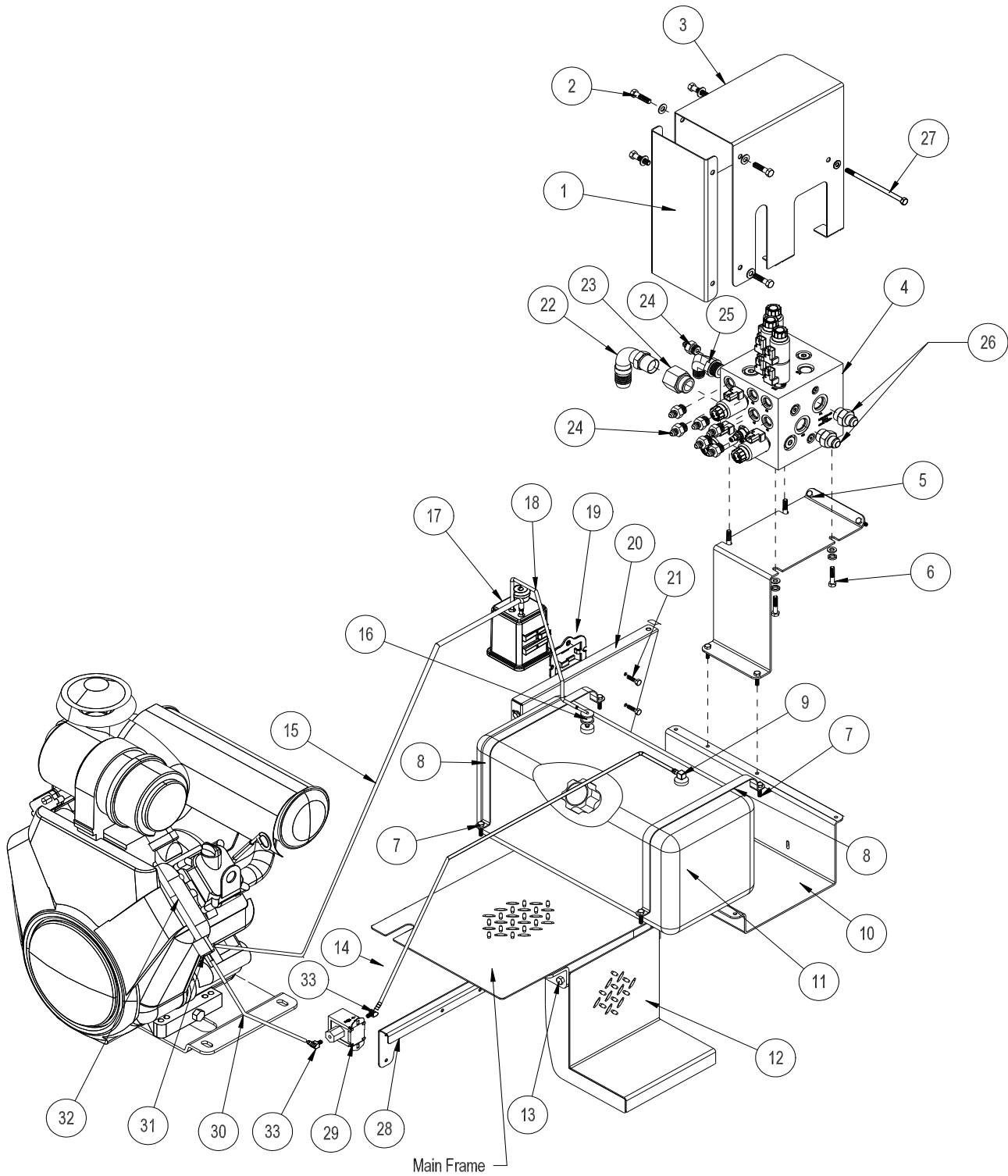

GAS TANK AND MANIFOLD PARTS LIST

REF#	PART#	DESCRIPTION	QUANTITY
1	76-601	Cover Panel	1
2	HB-516-18-100	Hex Bolt, $\frac{5}{16}$ - 18 x 1	4
	HW-516	Flat Washer, $\frac{5}{16}$	4
	HNTL-516-18	Nylon Lock Nut, $\frac{5}{16}$ - 18	4
3	76-603	Manifold Cover	1
4	76-560	Hydraulic Manifold	1
5	76-599	Valve Mount	1
	HB-14-20-124	Hex Bolt, $\frac{1}{4}$ - 20 x $1\frac{1}{4}$	4
	HNFL-14-20	Flange Whiz-loc Nut, $\frac{1}{4}$ - 20	4
6	HB-38-16-150	Hex Bolt, $\frac{3}{8}$ - 16 x $1\frac{1}{2}$	4
	HWL-38	Lock Washer, $\frac{3}{8}$	4
	HMB-12-14	Machine Bushing, $\frac{1}{2}$ x 14GA	4
7	HB-14-20-250	Hex Bolt, $\frac{1}{4}$ - 20 x $2\frac{1}{2}$	2
	HW-14	Flat Washer, $\frac{1}{4}$	2
	HNFL-14-20	Flange Whiz-loc Nut, $\frac{1}{4}$ - 20	2
8	76-585	Gas Tank Strap	2
9		Top Draw	1
10	76-591	Gas Tank Bracket	1
11	76-546	CARB Gas Tank - 8 Gallon	1
12	76-605	Step	1
13	HB-38-16-100	Hex Bolt, $\frac{3}{8}$ - 16 x 1	2
	HNTL-38-16	Nylon Lock Nut $\frac{3}{8}$ - 16	2
14	8800-44	$\frac{1}{4}$ " Fuel Line x 44"	1
	18-186	Hose Clamp	2
15	9025-60	$\frac{3}{16}$ " Fuel Line x 60"	1
	18-186	Hose Clamp	2
16		Roll-over Valve	1
17	8-738	Carbon Canister Assembly	1
18	8800-19	$\frac{1}{4}$ " Fuel Line x 19"	1
	18-186	Hose Clamp	2
19	8-688	Carbon Canister Mount	1
20	76-587	LH Side Panel	1
21	HB-14-20-075	Hex Bolt, $\frac{1}{4}$ - 20 x $\frac{3}{4}$	2
	HNFL-14-20	Flange Whiz-loc Nut, $\frac{1}{4}$ - 20	2
22	18-397	90° Hose Barb	1
23	18-471	Straight Thread Reducer	1
24	18-241	Straight Thread Connector	7
25	18-204	Elbow	1
26	15-702	Adapter	2
27	HB-516-18-700	Hex Bolt, $\frac{5}{16}$ - 18 x 7	1
	HW-516	Flat Washer, $\frac{5}{16}$	2
	HNTL-516-18	Nylon Lock Nut, $\frac{5}{16}$ - 18	1
28	76-632	Fuel Pump Mount	1
29	76-757	Electric Fuel Pump	1
30	8800-18	$\frac{1}{4}$ " Fuel Line x 18"	1
	18-186	Hose Clamp	2
31	50-403	Inline Fuel Filter	1
32	8800-14	$\frac{1}{4}$ " Fuel Line x 14"	1
	18-186	Hose Clamp	2
33	18-420	45° Barb	2

OIL TANK DRAWING

PARTS

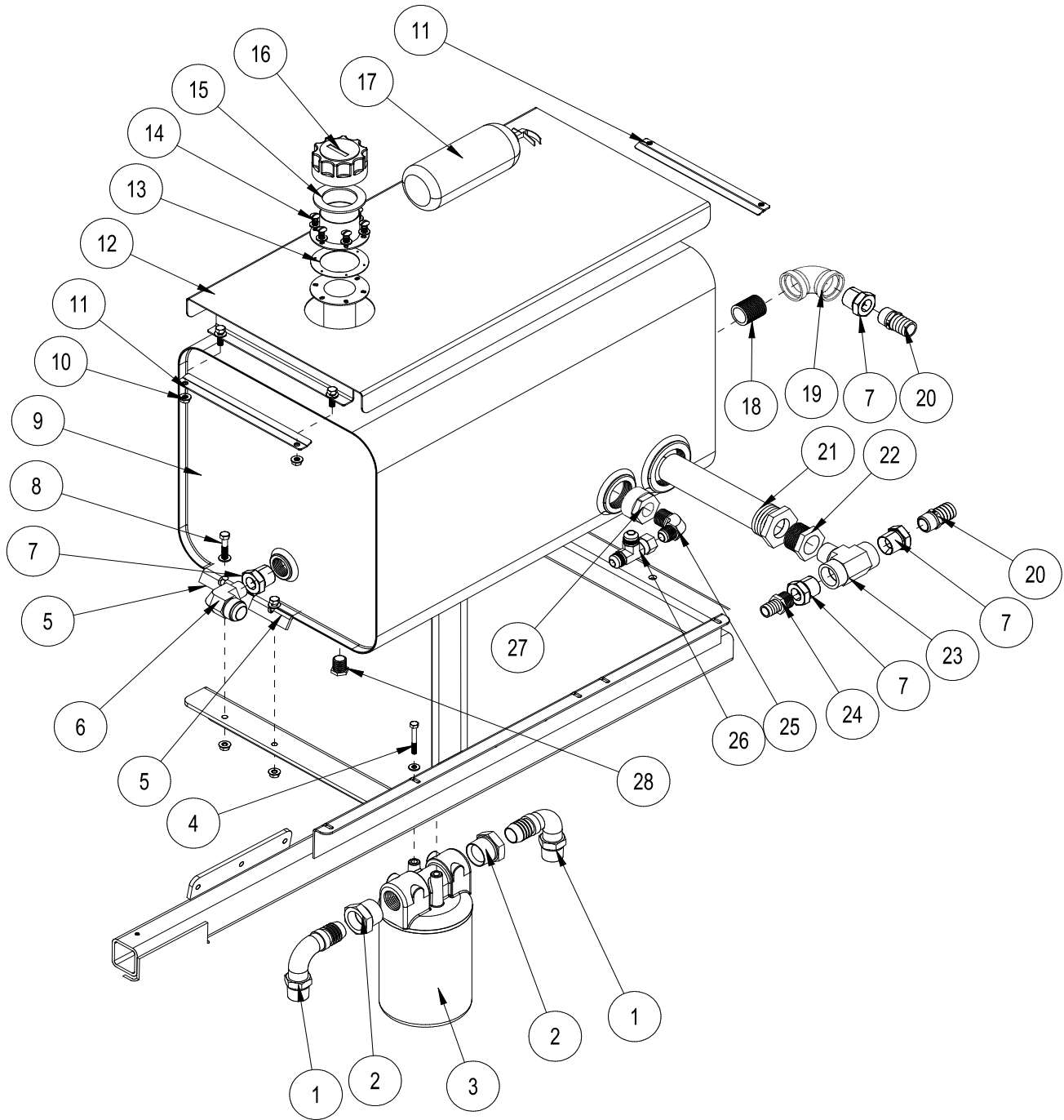

OIL TANK PARTS LIST

REF#	PART#	DESCRIPTION	QUANTITY
1	18-397	90° Hose Barb	2
2	18-396	Reducer	2
3	72-146	Oil Filter Assembly	1
	60-334	Filter Element	1
4	HB-14-20-200	Hex Bolt, 1/4 - 20 x 2	2
	HW-14	Washer, 1/4	2
5	75-792	Tank Hold-down	4
6	18-472	Elbow	1
7	18-107	Pipe Thread Reducer	4
8	HB-516-18-150	Hex Bolt, 5/16 - 18 x 1 1/2	3
	HW-516	Washer, 5/16	3
	HNTL-516	Nylon Lock Nut, 5/16 - 18	3
9	76-545	Oil Tank	1
10	HNFL-14-20	Flange Whiz-loc Nut, 1/4 - 20	4
	HW-14	Washer, 1/4	4
	HB-14-20-075	Hex Bolt, 1/4 - 20 x 3/4	4
11	76-592	Cover Strap	2
12	76-602	Tank Cover	1
13	13-586-02	Bottom Gasket	1
14	13-586-03	Filler Neck	1
	HSM-10-32-063	Machine Screw, #10-32 x 5/8	6
	HWL-10	Lock Washer, #10	6
15	13-586-01	Cap Gasket	1
16	13-747	Filler Breather	1
17	76-354	Fire Extinguisher	1
18	18-120	1" Black Nipple	1
19	18-050	1" Black Elbow	1
20	18-250	Barb Fitting	2
21	76-564	Tank Strainer	1
22	16-824	Pipe Reducer Bushing	1
23	18-473	Branch Tee	1
24	18-249	Barb Fitting	1
25	23-071	Male Connector	1
26	34-058	Swivel Tee	1
27	18-280	Reducer Bushing	1
28	18-069	Pipe Plug, 1/2"	1

ENGINE AND EXHAUST DRAWING

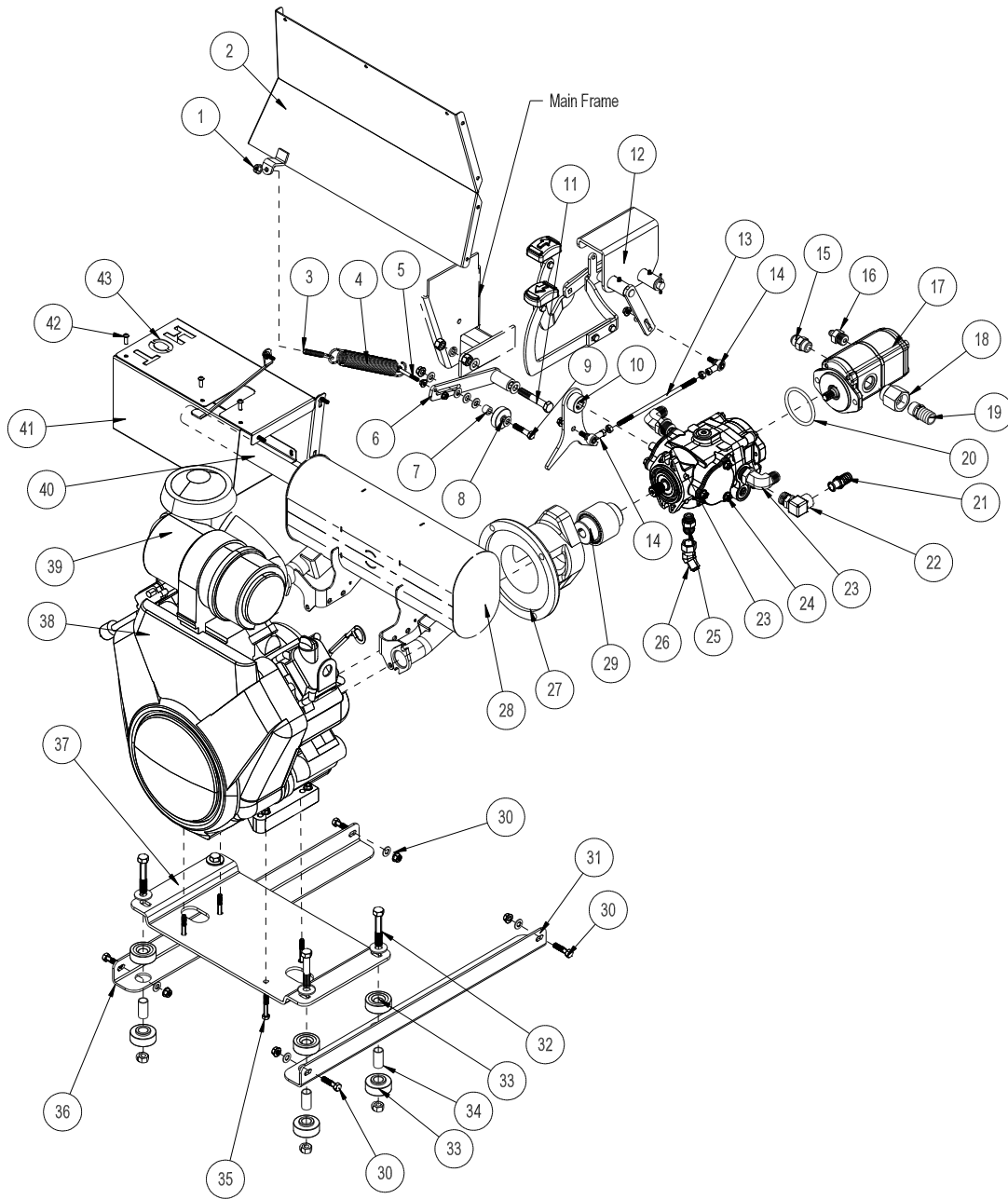

PARTS

Cyclonic air cleaner
76-395-04

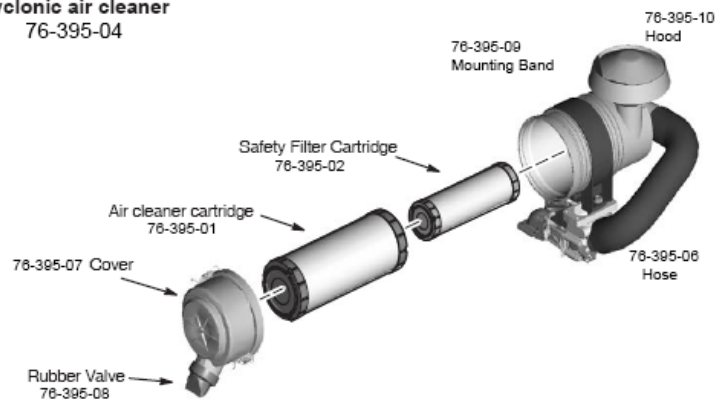

ENGINE AND EXHAUST PARTS LIST

REF#	PART#	DESCRIPTION	QUANTITY
1	HNTL-38-16	Nylon Lock Nut, $\frac{3}{8}$ - 16	1
2	76-590	Firewall	1
	9023	Ceramic Foil (7" x 20")	140 in ²
3	42-537	Spade Hex Bolt, $\frac{3}{8}$	1
4	21-445	Spring	1
5	HB-14-20-200	Hex Bolt, $\frac{1}{4}$ - 20 x 2	1
	HNFL-14-20	Flange Whiz-loc Nut, $\frac{1}{4}$ - 20	2
6	76-606	Idler Arm	1
	HG-14-28-180	Grease Fitting, $\frac{1}{4}$ - 28 x 180°	1
7	18-270	Oilite Bushing	1
8	14-266	Ball Bearing	1
9	HB-38-16-175	Hex Bolt, $\frac{3}{8}$ - 16 x 1 $\frac{3}{4}$	1
	HW-38	Flat Washer, $\frac{3}{8}$	5
	HNTL-38-16	Nylon Lock Nut, $\frac{3}{8}$ - 16	1
10	76-607	Swash Arm	1
11	HB12-13-300	Hex Bolt, $\frac{1}{2}$ - 13 x 3	1
	HWL-12	Lock Washer, $\frac{1}{2}$	1
	HNTL-12-13	Nylon Lock Nut, $\frac{1}{2}$ - 13	1
12	76-613	Pedal Relay	1
	HG-14-28-180	Grease Fitting, $\frac{1}{4}$ - 28 x 180°	2
13	43-220	Speed Boss Link	1
14	18-441	Ball Joint, $\frac{5}{16}$ - 24	2
	HN-516-24	Hex Nut, $\frac{5}{16}$ - 24	4
15	18-470	Straight Thread Connector	1
16	18-331	Adapter	1
17	76-540	Gear Pump	1
18	18-471	Straight Thread Reducer	1
19	18-250	Barb Fitting	1
20	23-145	O-ring	1
21	18-133	Barb Fitting	1
22	23-130	Elbow	1
23	18-204	Elbow	2
24	76-638	Hydrostatic Pump	1
25	18-267	Straight Thread Connector	1
26	18-273	Fitting	1
27	76-537	Pump Adapter	1
28	76-625	Muffler	1
29	76-465	Coupling Complete	1
	76-466	$\frac{7}{8}$ " Coupler Half	
	76-467	1 $\frac{1}{8}$ " Coupler Half	
	76-468	Coupler Sleeve	
30	HB-38-16-150	Hex Bolt, $\frac{3}{8}$ - 16 x 1 $\frac{1}{2}$	4
	HW-38	Flat Washer, $\frac{3}{8}$	4
	HNTL-38-16	Nylon Lock Nut, $\frac{3}{8}$ - 16	4
31	76-579	LH Motor Mount	1
32	HB-38-16-225	Hex Bolt, $\frac{3}{8}$ - 16 x 2 $\frac{1}{4}$	4
	HW-38	Flat Washer, $\frac{3}{8}$	4
	HNTL-38-16	Nylon Lock Nut, $\frac{3}{8}$ - 16	4
33	60-107	Rubber Bushing	8
34	60-168	Spacer	4
35	HB-716-14-150	Hex Bolt, $\frac{7}{16}$ - 14 x 1 $\frac{1}{2}$	4
	HWL-716	Lock Washer, $\frac{7}{16}$	4
36	76-578	RH Motor Mount	1
37	76-582	Engine Plate	1
38	76-636	Briggs 35HP Engine	1
39	76-395-04	Cyclonic Air Cleaner (comes with engine)	1
40	76-626	Tailpipe	1
	50-111	Muffler Clamp	1
41	76-630	Bottom Heat Shield	1
	9023	Ceramic Mat (13 x 13.5)	1
42	HSTP-14-20-075	Machine Screw, $\frac{1}{4}$ - 20 x $\frac{3}{4}$	6
	HNFL-14-20	Flange Whiz-loc Nut, $\frac{1}{4}$ - 20	6
43	76-629	Top Heat Shield	1
	9023	Ceramic Mat (14 x 15)	1

REEL BELT DRIVE DRAWING

PARTS

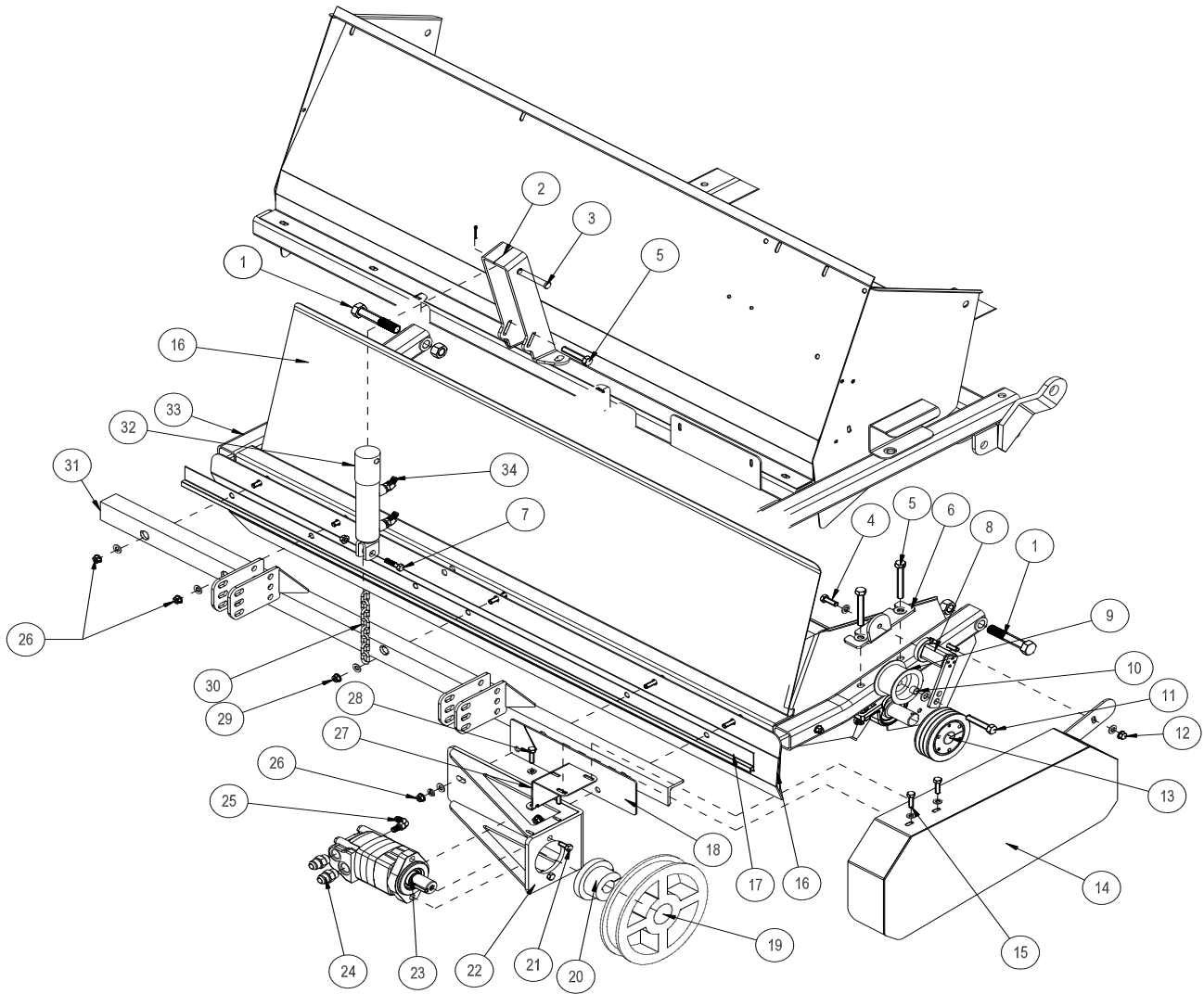

REEL BELT DRIVE PARTS LIST

REF#	PART#	DESCRIPTION	QUANTITY
1	HB-34-10-400	Hex Bolt, $\frac{3}{4}$ -10 x 4	2
	HNTL-34-10	Nylon Lock Nut, $\frac{3}{4}$ -10	2
2	75-827	Cylinder Bracket	1
3	HCP-12-350	Clevis Pin, $\frac{1}{2}$ x $3\frac{1}{2}$	1
	HP-18-100	Cotter Pin, $\frac{1}{8}$ x 1	1
4	HBM-10-1.5-30	Metric Hex Bolt, 10-1.5 x 30 (part of 78-224)	1
	HWLM-10	Metric Lock Washer, 10 (part of 78-224)	1
5	HB-12-13-400	Hex Bolt, $\frac{1}{2}$ -13 x 4	5
	HMB-12-14	Machine Bushing, $\frac{1}{2}$ x 14GA	4
	HNTL-12-13	Nylon Lock Nut, $\frac{1}{2}$ - 13	5
6	76-569	Idler Mount	1
7	HB-38-16-150	Hex Bolt, $\frac{3}{8}$ - 16 x $1\frac{1}{2}$	1
	HNTL-38-16	Nylon Lock Nut, $\frac{3}{8}$ - 16	1
8	78-224	Belt Tensioner	1
9	16-013	Idler Pulley	1
10	34-215	Spacer	1
11	HB-12-13-250	Hex Bolt, $\frac{1}{2}$ - 13 x $2\frac{1}{2}$ (part of 78-224)	1
	HMB-12-14	Machine Bushing, $\frac{1}{2}$ x 14GA	5
	HNCL-12-13	Center Nylon Lock Nut, $\frac{1}{2}$ - 13 (part of 78-224)	1
12	HB-38-16-300	Hex Bolt, $\frac{3}{8}$ - 16 x 3	1
	HW-38	Flat Washer, $\frac{3}{8}$	2
	HNTL-38-16	Nylon Lock Nut, $\frac{3}{8}$ -16	2
13	78-425	Pulley, 3-Groove	1
	78-431	Hub	1
14	76-604	Belt Guard	1
15	HBFL-516-18-075	Flange Hex Bolt, $\frac{5}{16}$ - 18 x $\frac{3}{4}$	2
	HNFL-516-18	Flange Whiz-loc Nut, $\frac{5}{16}$ -18	2
16	75-808	Front Baffle	1
17	76-438	Brush Channel	1
18	76-598	Shim	1
19	76-581	Pulley, 3-groove	1
20	76-580	Hub	1
	HWK-516-100	Woodruff Key, $\frac{5}{16}$ x 1	1
21	HB-12-13-200	Hex Bolt, $\frac{1}{2}$ - 13 x 2	2
	HWL-12	Lock Washer, $\frac{1}{2}$ - 13	2
22	76-608	Motor Mount	1
23	76-539	Reel Motor	1
24	18-470	Straight Thread Connector	2
25	18-185	Elbow	1
26	HB-38-16-350	Hex Bolt, $\frac{3}{8}$ - 16 x $3\frac{1}{2}$	4
	HW-38	Flat Washer, $\frac{3}{8}$	8
	HNTL-38-16	Nylon Lock Nut, $\frac{3}{8}$ - 16	4
27	76-567	Belt Guard Mount	1
28	HB-14-20-075	Hex Bolt, $\frac{1}{2}$ -20 x $\frac{3}{4}$	2
	HNFL-14-20	Flange Whiz-loc Nut, $\frac{1}{4}$ - 20	2
29	HB-38-16-400	Hex Bolt, $\frac{3}{8}$ - 16 x 4	1
	HW-38	Washer, $\frac{3}{8}$	2
	HNTL-38-16	Nylon Lock Nut, $\frac{3}{8}$ - 16	1
30	8820-8	Machine Chain, 8-links	1
31	76-356	Castor Mount Bracket	1
32	76-478	Hydraulic Cylinder	1
	14-531	Seal Kit	1
33	75-787	Reel Frame	1
34	18-188	45° Elbow	2
NS	76-621	Belt, 3V x 590	3

REAR AXLE DRAWING

PARTS

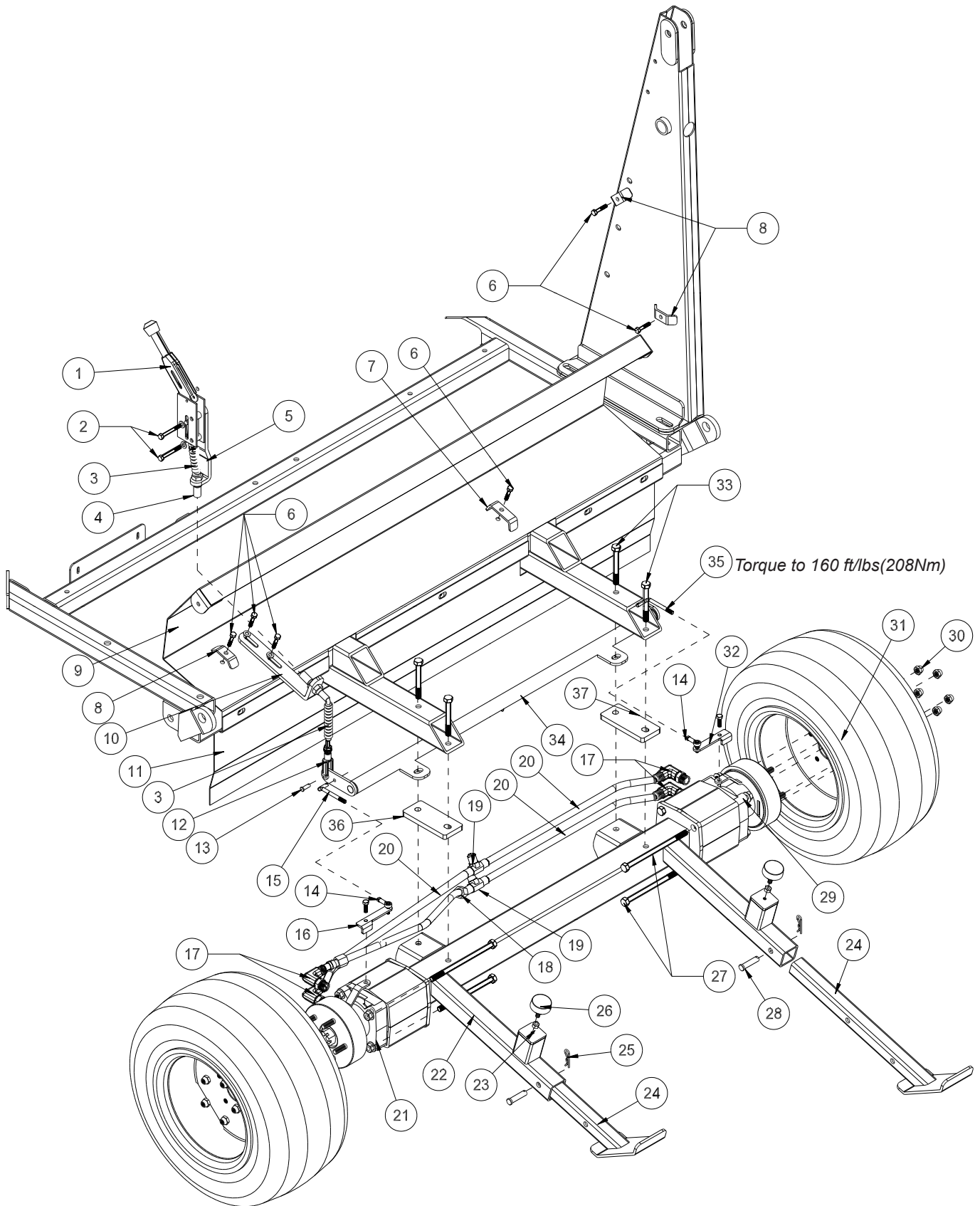

REAR AXLE PARTS LIST

REF#	PART#	DESCRIPTION	QUANTITY
1	60-106	Park Brake Lever Kit	1
2	HB-516-18-275	Hex Bolt, $\frac{5}{16}$ - 18 x $2\frac{3}{4}$	2
	HNTL-516-18	Nylon Lock Nut, $\frac{5}{16}$ - 18	2
3	60-536	Bellows	2
4	76-225	Brake Cable with Nuts	1
5	45-605	Park Brake Bracket	1
6	HB-38-16-150	Hex Bolt, $\frac{3}{8}$ - 16 x $1\frac{1}{2}$	6
	HW-38	Flat Washer, $\frac{3}{8}$	12
	HNTL-38-16	Nylon Lock Nut, $\frac{3}{8}$ - 16	6
7	75-614	Hose Clamp	1
8	13-099	Hose Clamp	3
9	76-234	Rear Chute Baffle	1
	8947-60	Trim Seal x 60"	1
10	76-218	Brake Cable Bracket	1
11	76-233	Rear Beater Panel	1
12	11-100	Linkage Yoke, $\frac{5}{16}$	1
13	HCP-516-100	Clevis Pin, $\frac{5}{16}$ x 1	1
	HP-18-075	Cotter Pin, $\frac{1}{8}$ x $\frac{3}{4}$	1
14	18-441	Ball Joint	2
	HN-516-24	Hex Nut, $\frac{5}{16}$ - 24	4
15	76-634	LH Brake Rod	1
	HP-18-075	Cotter Pin, $\frac{1}{8}$ x $\frac{3}{4}$	1
16	76-595	LH Brake Lever	1
17	34-122	Short Elbow	4
18	76-541	Hydraulic Tube Assembly	1
19	34-057	Tee Fitting	2
20	20-656	Hydraulic Tube Assembly	3
21	76-542	LH Wheel Motor	1
	45-065-01	Studs	4
22	76-616	Rear Axle	1
23	HN-38-16	Hex Nut, $\frac{3}{8}$ - 16	4
24	75-723	Rear Skid	2
25	HHP-18	Bridge Pin, $\frac{1}{8}$	2
26	50-081	Rubber Bumper	2
27	HB-12-13-750	Hex Bolt, $\frac{1}{2}$ - 13 x $7\frac{1}{2}$	8
	HMB-12-14	Machine Bushing, $\frac{1}{2}$ x 14GA	8
	HNFL-12-13	Flange Whiz-loc Nut, $\frac{1}{2}$ - 13	8
28	HCP-12-225	Clevis Pin, $\frac{1}{2}$ x $2\frac{1}{4}$	2
	HHP-18	Bridge Pin, $\frac{1}{8}$	2
29	76-543	RH Wheel Motor	1
	45-065-01	Studs	4
30	HNL-12-20	Lug Nut, $\frac{1}{2}$ - 20	10
31	76-756	Rear Tire and Wheel	2
	16-225-01	Tire, 24 x 13.00 x 12 4-ply	2
	76-756-02	Rim	2
32	76-594	RH Brake Lever	1
33	HB-12-13-450	Hex Bolt, $\frac{1}{2}$ - 13 x $4\frac{1}{2}$	4
	HW-12	Flat Washer, $\frac{1}{2}$	2
	HNTL-12-13	Nylon Lock Nut, $\frac{1}{2}$ - 13	4
34	76-229	Park Brake Relay	1
35	76-635	RH Brake Rod	1
	HP-18-075	Cotter Pin, $\frac{1}{8}$ x $\frac{3}{4}$	1
36	76-639	Axle Shim	2

FINGER/BRUSH REEL DRAWING

PARTS

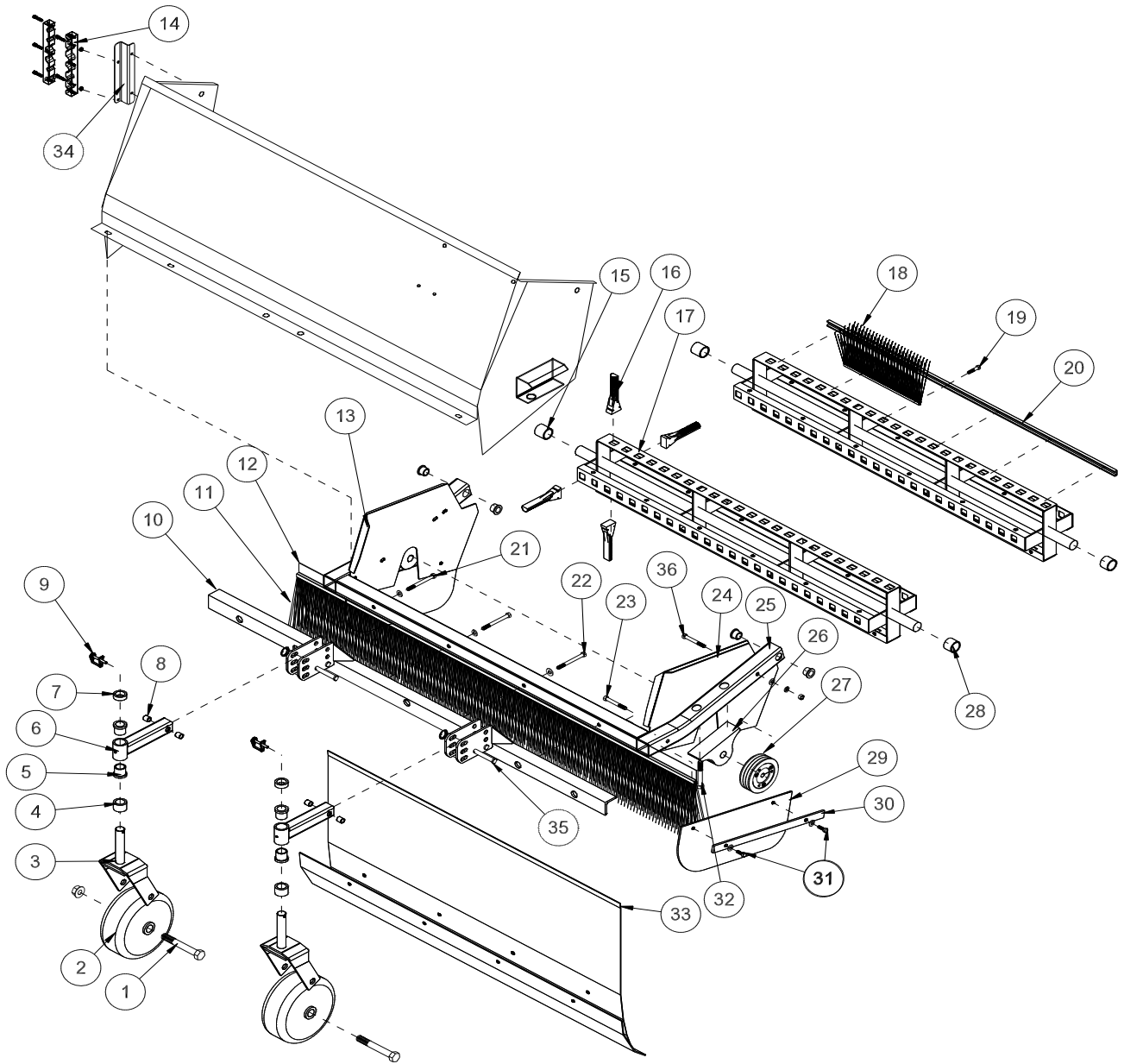

FINGER /BRUSH REEL PARTS LIST

REF#	PART#	DESCRIPTION	QUANTITY
1	HB-34-10-550	Hex Bolt, $\frac{3}{4}$ - 10 x $5\frac{1}{2}$	2
	HNTL-34-10	Nylon Lock Nut, $\frac{3}{4}$ - 10	2
2	33-435	Tire and Wheel	2
	33-435-02	Wheel with Roller Bearing	
	33-435-03	Roller Bearing	
	33-435-04	Bushing	
3	48-046	Castor Fork	2
	HMB-100-10	Machine Bushing 1 x 10GA	8
4	29-585	Spacer Height Adjustment	2
5	18-223	Bushing (part of 76-355)	2 per
6	76-355	Arm	2
7	29-584	Height Adjustment Spacer, $\frac{1}{2}$ "	2
8	20-019	Bushing (part of 76-355)	2 per
9	29-541	Lock Pin, $\frac{1}{4}$	2
10	76-356	Castor Mount Bracket	1
11	76-439	Brush	1
12	76-438	Brush Channel	1
13	75-799	Side Plate RH.	1
14	76-336	Hose Clamp	1
15	75-686	Spacer, $1\frac{1}{4}$ ID x $1\frac{3}{8}$	1
16	75-506	Sweeper Finger	116
17	75-780	Finger Reel	1
18	76-330	Brush	4
19	HB-516-18-125	Hex Bolt, $\frac{5}{16}$ - 18 x $1\frac{1}{4}$	28
	HNTL-516-18	Nylon Lock Nut, $\frac{5}{16}$ - 18	28
20	76-313	Clamp	4
21	HB-38-16-350	Hex Bolt, $\frac{3}{8}$ - 16 x $3\frac{1}{2}$	2
	HW-38	Flat Washer, $\frac{3}{8}$	4
	HNTL-38-16	Nylon Lock Nut, $\frac{3}{8}$ - 16	2
22	HB-38-16-400	Hex Bolt, $\frac{3}{8}$ - 16 x 4	1
	HW-38	Flat Washer, $\frac{3}{8}$	2
	HNTL-38-16	Nylon Lock Nut, $\frac{3}{8}$ - 16	1
23	HB-38-16-275	Hex Bolt, $\frac{3}{8}$ - 16 x $2\frac{3}{4}$	3
	HW-38	Flat Washer, $\frac{3}{8}$	7
	HNTL-38-16	Nylon Lock Nut, $\frac{3}{8}$ - 16	4
24	75-800	Left Side Plate	1
25	75-787	Reel Frame	1
	18-221	Flange Bushing (part of 75-787)	4
26	75-511	Pillow Block, $1\frac{1}{4}$ Bore	2
27	78-425	Pulley, 3-Groove	1
28	75-834	Spacer, $1\frac{1}{4}$ ID x $1\frac{1}{8}$	1
29	76-210	Matting $7\frac{1}{2}$ x 18	2
30	76-213	Reel Guard Strap	2
31	HB-516-18-100	Hex Bolt, $\frac{5}{16}$ - 18 x 1	4
	HNTL-516-18	Nylon Lock Nut, $\frac{5}{16}$ - 18	4
32	HB-12-13-350	Hex Bolt, $\frac{1}{2}$ - 13 x $3\frac{1}{2}$	4
	HMB-12-14	Machine Bushing, $\frac{1}{2}$ - 14	4
	HNTL-12-13	Nylon Lock Nut, $\frac{1}{2}$ - 13	4
33	75-808	Front Baffle	1
34	76-574	Hose Clamp Mount	1
35	HCP-12-250	Clevis Pin, $\frac{1}{2}$ x $2\frac{1}{2}$	4
	76-483	Knock-Out Ring	4
36	HB-38-16-300	Hex Bolt, $\frac{3}{8}$ - 16 x 3	1
	HW-38	Flat Washer, $\frac{3}{8}$	2
	HNTL-38-16	Nylon Lock Nut, $\frac{3}{8}$ - 16	1

HOPPER LIFT CYLINDER DRAWING

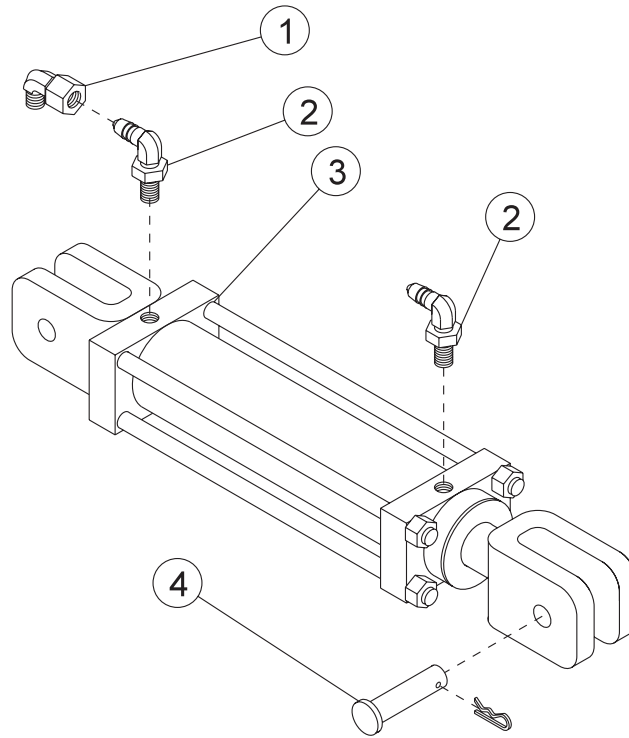

PARTS

REF#	PART#	DESCRIPTION	QUANTITY
1	18-202	Elbow	1
2	23-167	Elbow	2
3	76-627	Hydraulic Cylinder	1
	76-242-01	Seal Kit	1
4	HCP-100-325	Clevis Pin, 1 x 3 ¹ / ₄	2
	HHP-.177	Bridge Pin, .177 x 3 ³ / ₄	2

2 Cylinder Assemblies per Machine

TORQUE SPECIFICATION

PISTON NUT.....	165 FT/LBS (214.5 NM)
TIE ROD NUT	30 FT/LBS (39 NM)
CLEVIS NUT	46 FT/LBS (59.8 NM)

REEL LIFT CYLINDER DRAWING

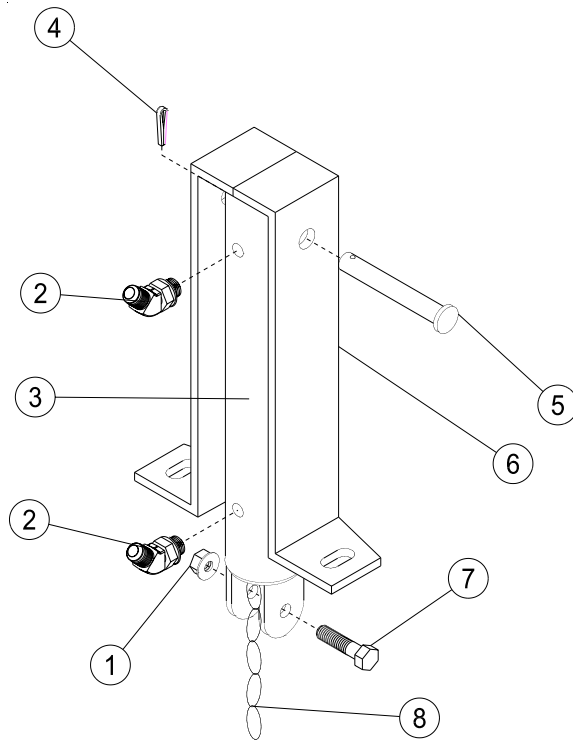

REF#	PART#	DESCRIPTION	QUANTITY
1	HNTL-38-16	Nylon Lock Nut, $\frac{3}{8}$ - 16	2
2	18-188	Elbow, $\frac{3}{8}$ SAE	2
3	76-478	Hydraulic Cylinder, 2 x 7 x $\frac{3}{4}$	1
	14-531	Seal Kit	
4	HP-18-100	Cotter Pin, $\frac{1}{8}$ x 1	1
5	HCP-12-350	Clevis Pin, $\frac{1}{2}$ - 3 $\frac{1}{2}$	1
6	75-827	Cylinder Bracket	1
7	HB-38-16-150	Hex Bolt, $\frac{3}{8}$ - 16 x 1 $\frac{1}{2}$	1
8	8820-8	Machine Chain St. Link	1

HOPPER DRAWING

PARTS

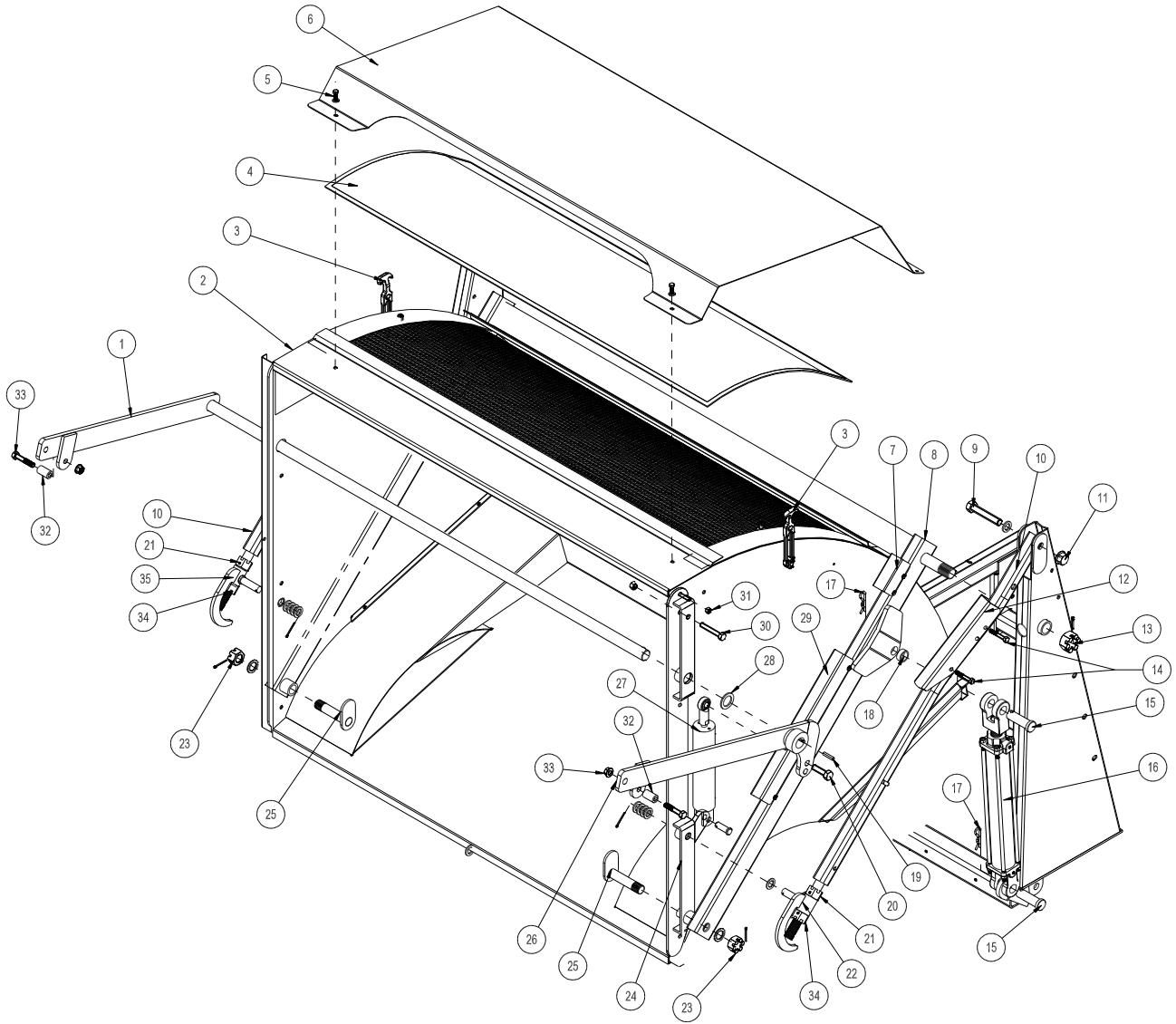

HOPPER PARTS LIST

REF#	PART#	DESCRIPTION	QUANTITY
1	76-414	Left Tailgate Dump Bar	1
2	76-237	Hopper	1
3	15-437	Latch	2
	HRS-316-1125	Rivet, $\frac{3}{16}$ x $1\frac{1}{8}$	4
	HRW-316	Rivet Washer, $\frac{3}{16}$	4
	HW-316	Washer, $\frac{3}{16}$	2
4	76-261	Hopper Screen	1
5	HB-516-18-075	Hex Bolt, $\frac{5}{16}$ - 18 x $\frac{3}{4}$	6
	HW-516	Flat Washer, $\frac{5}{16}$	6
	HNTL-516-18	Nylon Lock Nut, $\frac{5}{16}$ - 18	6
6	76-359	Hopper Screen Cover	1
7	76-161	Short Metal Hose Guard	1
8	76-211	Arm Pivot Tube	1
9	HB-34-10-400	Hex Bolt, $\frac{3}{4}$ - 10 x 4	2
	HMB-34-10	Machine Bushing, $\frac{3}{4}$ - 10GA	2
10	76-230	Hopper Dump Arm	2
11	HNTL-34-10	Nylon Lock Nut, $\frac{3}{4}$ - 10	2
12	75-653	Hopper Safety Lift	2
13	HNA-114-12	Axle Nut, $1\frac{1}{4}$ - 12	2
	HP-316-100	Cotter Pin, $\frac{3}{16}$ x 1	2
14	HB-38-16-225	Hex Bolt, $\frac{3}{8}$ - 16 x $2\frac{1}{4}$	4
	HNW-38-16	Wing Nut, $\frac{3}{8}$ - 16	4
15	HCP-100-325	Clevis Pin, 1 x $3\frac{1}{4}$	4
16	76-627	Hydraulic Cylinder	2
17	HHP-.177	Bridge Pin, .177 x $3\frac{3}{4}$	2
18*	76-288	Spacer	2
19	HKSQ-14-150	Machine Key, $\frac{1}{4}$ x $\frac{1}{4}$ x $1\frac{1}{2}$	1
	HSSHS-516-18-038	Set Screw, $\frac{5}{16}$ - 18 x $\frac{3}{8}$	1
	HRP-38-250	Roll Pin, $\frac{3}{8}$ x $2\frac{1}{2}$	1
20	HB-58-11-200	Hex Bolt, $\frac{5}{8}$ - 11 x 2	1
	HMB-58-14	Machine Bushing, $\frac{5}{8}$ x 14GA	3
	HNCL-58-11	Center Nylon Lock Nut, $\frac{5}{8}$ - 11	1
21	HNA-100-14	Slotted Hex Nut, 1 - 14	2
22	48-148	Right Adjustment Sleeve	1
	HMB-34-14	Machine Bushing, $\frac{3}{4}$ x 14GA	1
	HMB-34-10	Machine Bushing, $\frac{3}{4}$ x 10GA	4
	HP-18-150	Cotter Pin, $\frac{1}{8}$ x $1\frac{1}{2}$	1
23	HMB-100-14	Machine Bushing, 1 x 14GA	2
	HNA-100-14	Slotted Hex Nut, 1 - 14	2
	HP-18-150	Cotter Pin, $\frac{1}{8}$ x $1\frac{1}{2}$	2
24	76-215	Right Hinge Strap (Shown)	1
	76-216	Left Hinge Strap	1
25	75-569	Swivel Pin	2
26	76-413	Right Tailgate Dump Bar	1

*Spacer **MUST** be to the outside of the tab on the Pivot Arm with the tab and the spacer inside the cylinder yoke.

(Continued on next page)

HOPPER DRAWING

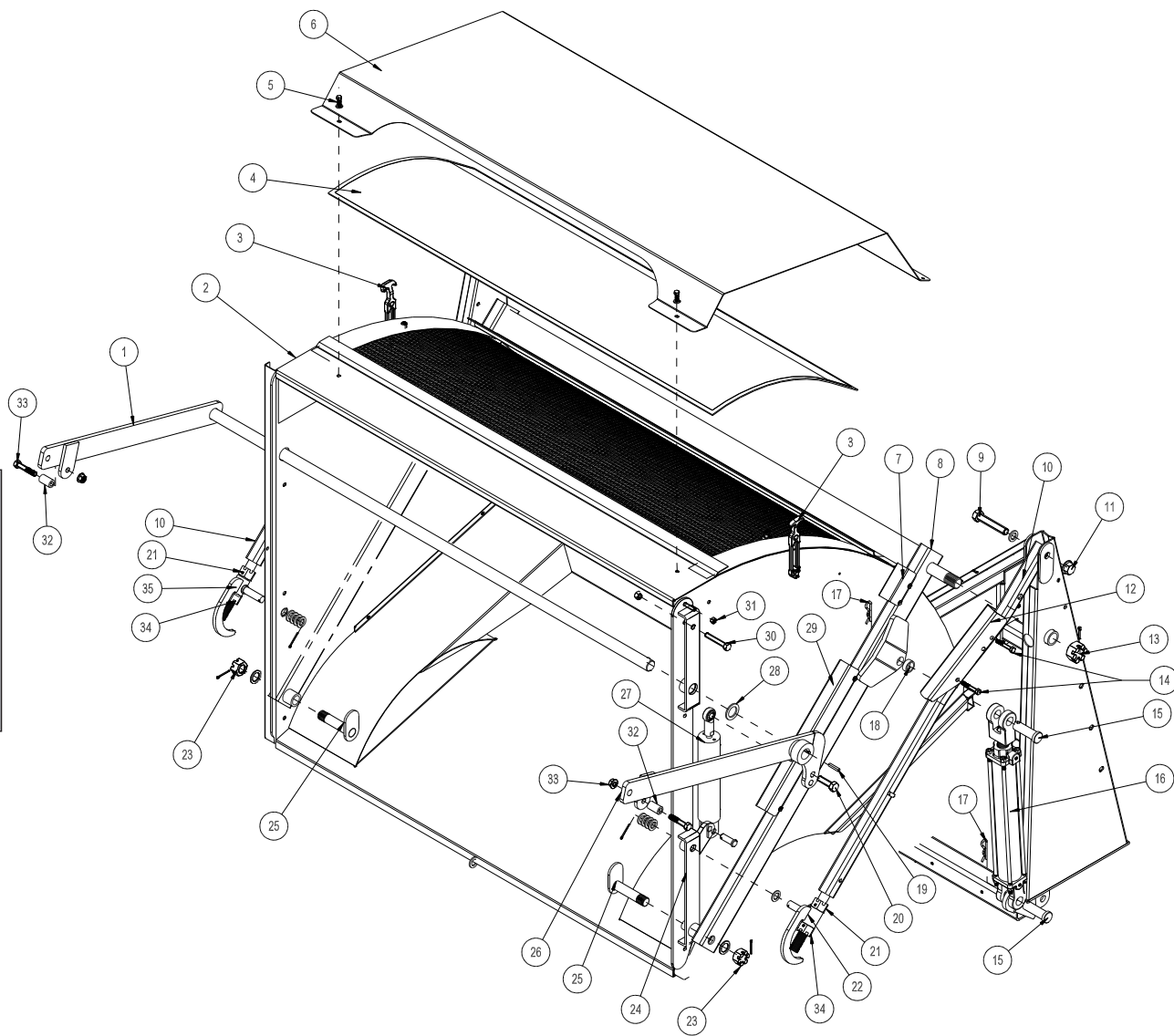

PARTS

HOPPER PARTS LIST

REF#	PART#	DESCRIPTION	QUANTITY
27	15-839	Hydraulic Cylinder	1
	18-168	Elbow	2
	18-154	Rod End	1
	HG-14-28-180	Grease Fitting, 1/4 - 28 x 180° (part of rod end)	1
	HCP-58-175	Clevis Pin, 5/8 x 1 3/4	1
	HHP-18	Bridge Pin, 1/8	1
28	HMB-114-10	Machine Bushing, 1 1/4 x 10 GA	2 As Req'd
29	76-159	Hose Guard, Long	1
30	HB-12-13-300	Hex Bolt, 1/2 - 13 x 3	2
	HN-12-13	Hex Nut, 1/2 - 13	2
	HNCL-12-13	Center Nylon Lock Nut, 1/2 - 13	2
31	HNCL-38-16	Center Nylon Lock Nut, 3/8 - 16	8
	HB-38-16-100	Hex Bolt, 3/8 - 16 x 1	8
32	42-702	Spacer	2
33	HB-12-13-250	Hex Bolt, 1/2 - 13 x 2 1/2	2
	HNCL-12-13	Center Nylon Lock Nut, 1/2 - 13	2
34	75-704	Castle Nut, 1 - 14	2
	HSSHS-38-16-038	Set Screw, 3/8 - 16 x 3/8	2
35	48-153	Left Adjustment Sleeve	1
	HMB-34-14	Machine Bushing, 3/4 x 14GA	1
	HMB-34-10	Machine Bushing, 3/4 x 10GA	4
	HP-18-150	Cotter Pin, 1/8 x 1 1/2	1

TAILGATE DRAWING

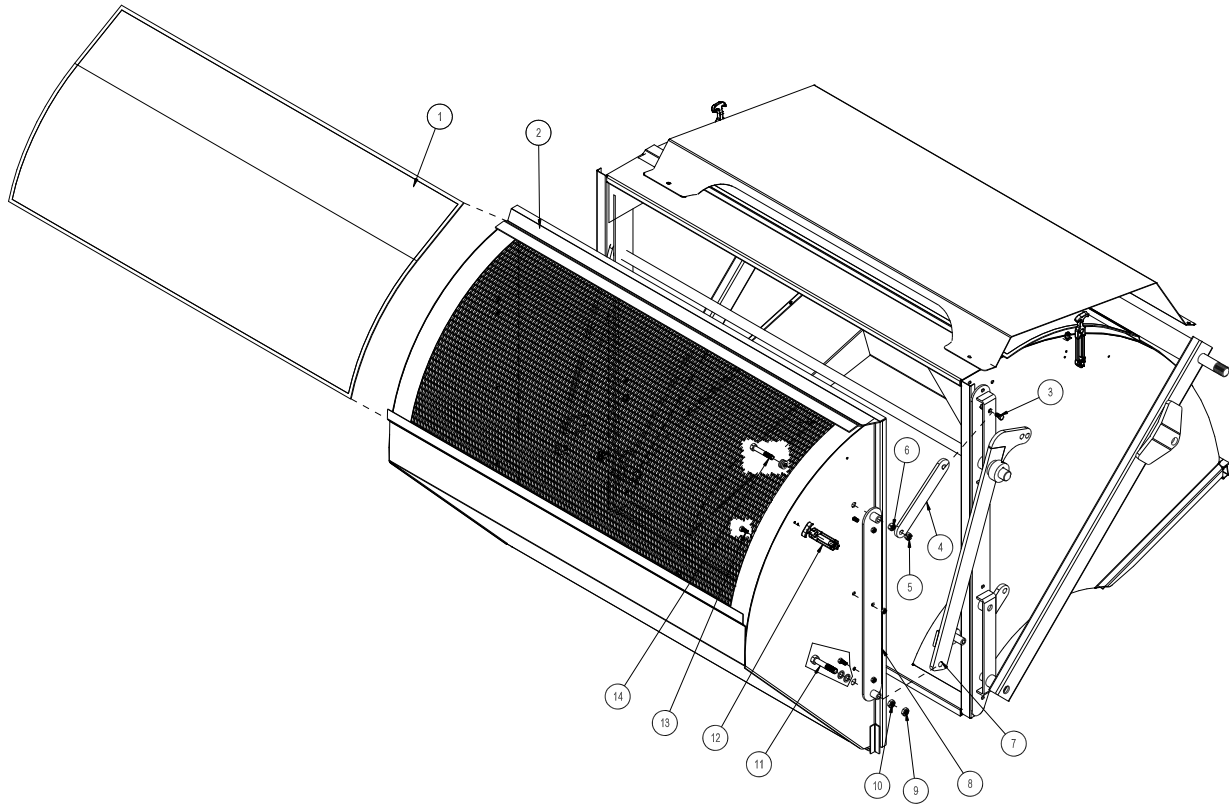

Parts

REF#	PART#	DESCRIPTION	QUANTITY
1	76-262	Tailgate Screen	1
2	76-243	Tailgate	1
3	HB-12-13-300	Hex Bolt, 1/2 - 13 x 3	2
	HN-12-13	Hex Nut, 1/2 - 13	2
	HNCL-12-13	Center Nylon Lock Nut, 1/2 - 13	2
4	75-564	Tailgate Hinge	2
5	HNCL-12-13	Center Nylon Lock Nut, 1/2 - 13	2
6	HN-12-13	Hex Nut, 1/2 - 13	2
7	76-413	Right Tailgate Dump Bar	1
8	75-565	Tailgate Hinge Strap	2
9	HNCL-58-11	Center Nylon Lock Nut, 5/8 - 11	2
10	HNJ-58-18	Jam Nut, 5/8 - 18	2
11	HB-58-18-325	Hex Bolt, 5/8 - 18 x 3 1/4	2
	HMB-58-14	Machine Bushing, 5/8 x 14GA	10
12	15-437	Latch	2
	HRS-316-1125	Rivet, 3/16 x 1 1/8	2
	HRS-316-100	Rivet, 3/16 x 1	4
	HRW-316	Rivet Washer, 3/16	4
	HW-316	Flat Washer, 3/16	2
13	HNCL-38-16	Center Nylon Lock Nut, 3/8 - 16	6
	HB-38-16-100	Hex Bolt, 3/8 - 16 x 1	6
14	HB-12-13-300	Hex Bolt, 1/2 - 13 x 3	2
	HMB-12-14	Machine Bushing, 1/2 x 14GA	6

TAILGATE CYLINDER DRAWING

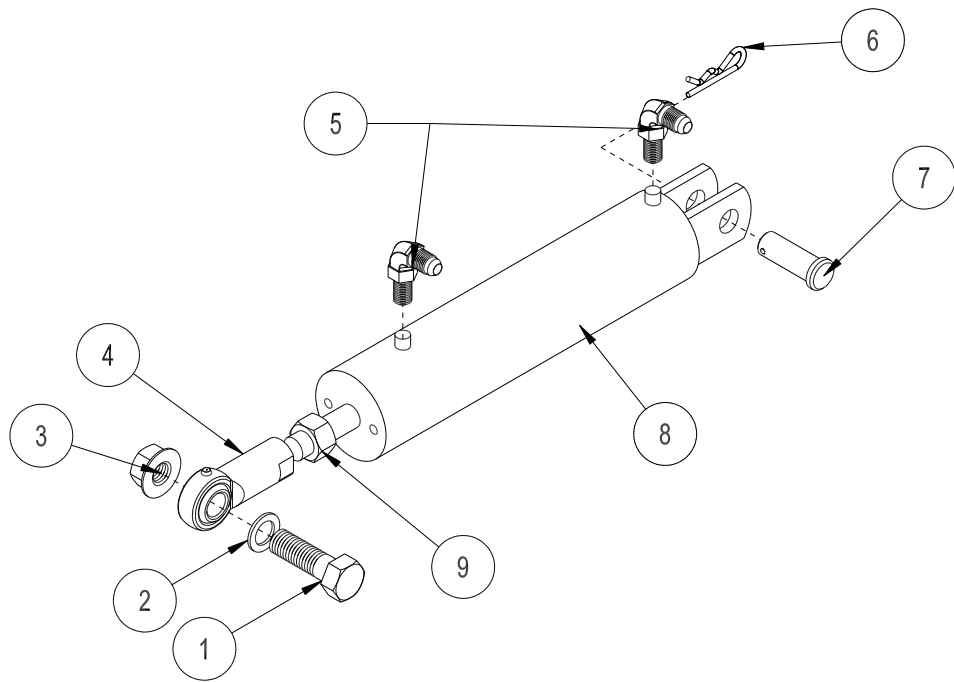

REF#	PART#	DESCRIPTION	QUANTITY
1	HB-58-11-200	Hex Bolt, $\frac{5}{8}$ - 11 x 2	1
2	HMB-58-14	Machine Bushing, $\frac{5}{8}$ - 14GA	1
3	HNTL-58-11	Nylon Lock Nut, $\frac{5}{8}$ - 11GA	1
4	18-154	Rod End	1
	HG-14-28-180	Grease Fitting, $\frac{1}{4}$ - 28 x 180°	1
5	18-168	Elbow	2
6	HHP-18	Bridge Pin, $\frac{1}{8}$	1
7	HCP-58-175	Clevis Pin, $\frac{5}{8}$ x $1\frac{3}{4}$	1
8	15-839	Hydraulic Cylinder	1
	15-839-01	Seal Kit	1
9	HNJ-58-18	Jam Nut, $\frac{5}{8}$ - 18	1

Parts

76-638 HYDROSTATIC PUMP DRAWING

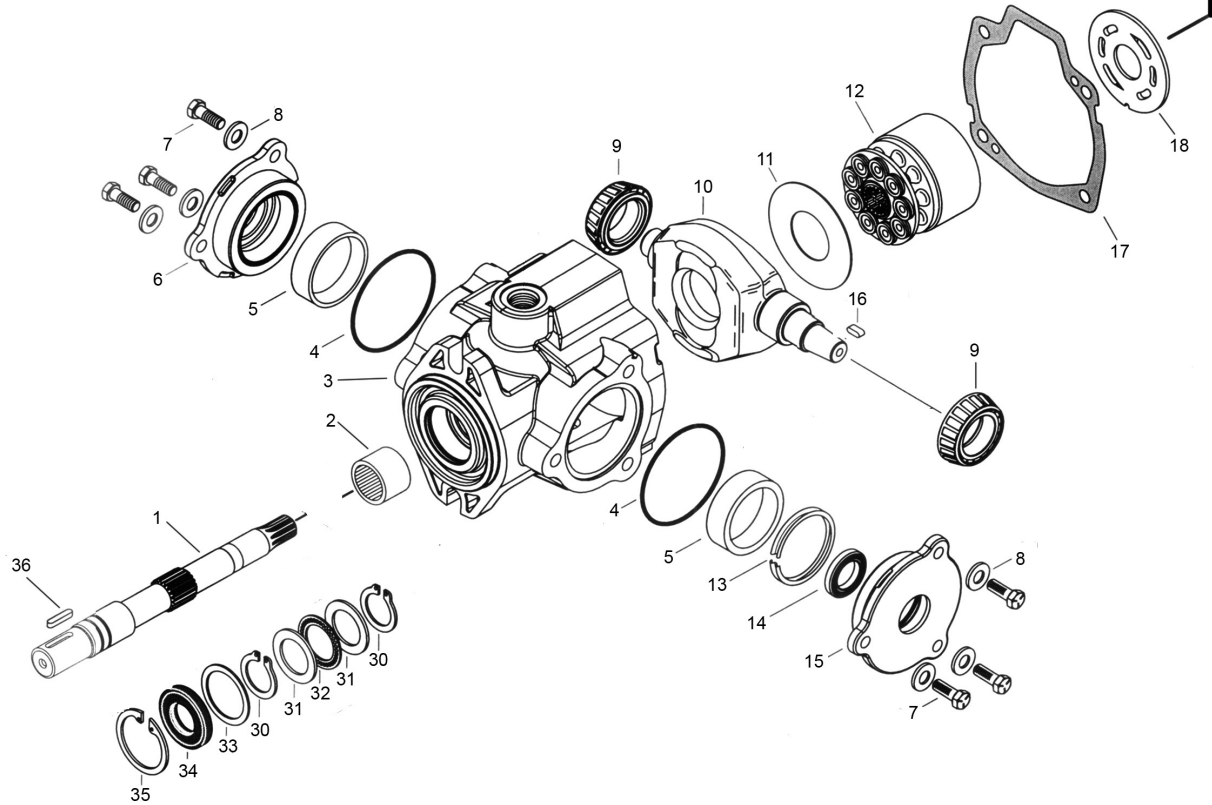
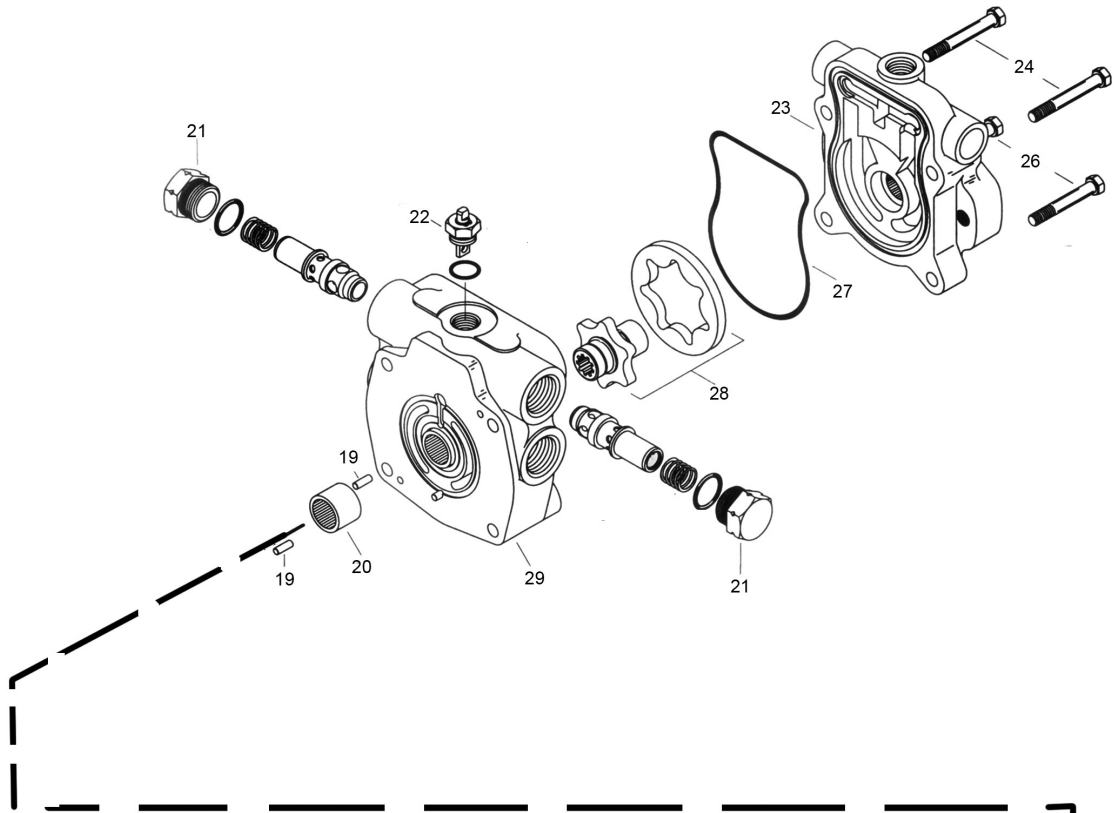

Parts

76-638 HYDROSTATIC PUMP PARTS LIST

REF#	PART#	DESCRIPTION	QUANTITY
1	76-398-01	Drive Shaft (splined)	1
2		Needle Bearing (with housing)	1
3	77-239-01	Housing	1
4	77-239-02	O-Ring	1
5	77-239-03	Thrust Bearing	2
6	77-239-04	Trunnion Cover	1
7	77-239-05	Pan Head Screw	2
8	77-239-06	Washer	6
9	77-239-07	Cone Bearing	2
10	77-239-08	Cam Plate	1
11	77-239-09	Swash Plate Insert	1
12	60-343-21	Rotating Kit	1
13	77-239-10	Crush Ring	1
14*	60-343-12	Shaft Seal	1
15	77-239-11	Seal Cover	1
16		Key	1
17*	77-239-13	Gasket	1
18	76-482-01	Back Plate	1
19		Dowel Pin	2
20		Bearing	1
21	77-239-15	Relief Valve	2
22	77-239-16	Tow Valve Assembly	1
23		Charge Pump Adaptor	1
24	77-239-17	Cap Screw	2
26	77-239-18	Cap Screw	2
27*	77-239-19	O-Ring	1
28	60-343-43	Gerotor and Coupler	1
29		End Cover Assembly	1
30*	77-239-21	Retaining Ring	2
31	60-343-05	Bearing Race	1
32	60-343-06	Thrust Bearing	1
33	60-343-03	Washer	2
34*	60-343-02	Shaft Seal	1
35*	60-343-01	Retaining Ring	1
36	60-343-49	Key	1
*	77-239-23	Seal Repair Kit	

Disassembly

The following disassembly procedure applies to a single pump with or without gear pump. The repair procedure for tandem pumps, once they are separated, is basically the same. The basic configuration differences between a single and tandem pumps are the backplates, pump shafts and housing assemblies. In most cases, only the rear pump of tandem units contain a charge pump, which is common to both the front and rear pump. The rear tandem pump does not incorporate a shaft seal.

Thoroughly clean the Eaton Model 70160 or 78162 variable displacement pump before any repairs are attempted. When working on tandem pumps, separate the front and rear pumps first.

- 1** Support the pump with the input shaft down. Use a 1/2 in. socket or end wrench to remove the pump adapter cover plate or gear pump (see Figure 2).
- 2** Use a pick or similar tool to remove the adapter cover plate or gear pump o-ring. (See Figure 3)
- 3** Use a 7/16 in. Allen wrench or bit socket remover to remove the charge pressure relief valve spring retainer from the pump adaptor assembly (see Figure 4).
- 4** Use a pencil magnet or similar tool to carefully remove the charge pressure spring and poppet from the pump adaptor assembly. (See Figure 5) Use caution not to drop the charge pump poppet into the pump adaptor assembly.
- 5** The charge pressure relief valve and poppet may be of the standard or high pressure type. The (6.9 to 10.3 bar [100 to 150 PSI]) standard spring and poppet are shown on the bottom and the optional high pressure (13.7 to 20.7 bar [200 to 300 PSI]) spring and poppet is shown on the top.

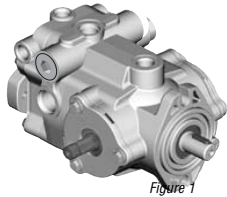

Figure 1



Figure 2

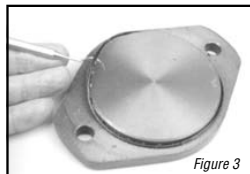

Figure 3

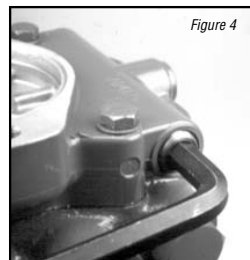

Figure 4

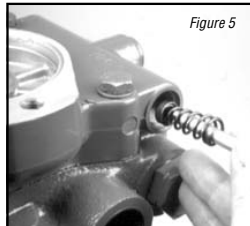

Figure 5

The same charge pressure relief valve spring retainer is used with either the standard or high pressure (see Figure 6).

- 6** Use a 7/8 in. socket or end wrench to remove the optional bypass valve assembly from the backplate (see Figure 7).
- 7** The internal seal may be replaced by first removing the small retaining ring on the end of the bypass valve. Remove and replace the o-rings (see Figure 8).
- 8** Use a 9/16 in. hex key to remove the two high pressure relief valves from the pumps backplate assembly (see Figure 9). Remove relief valve as shown from each side (see Figure 10). Each system relief valve S/A is identified by both its part number and relief valve setting as shown in Parts Information manual.



Figure 6

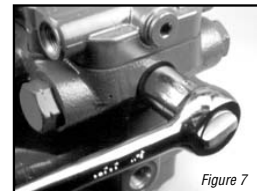

Figure 7

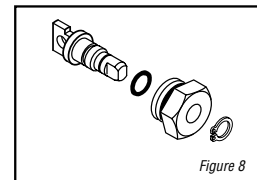

Figure 8

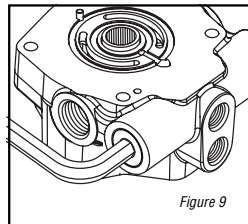

Figure 9

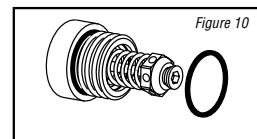

Figure 10

- 9** Firmly support the pump assembly. Use a 1/2 in. socket or end wrench to remove the four cap screws retaining the charge pump adaptor assembly.

- 10** With the cap screws removed, remove the charge pump adaptor assembly from the backplate (see Figure 11).

Note: The front pump assemblies do not have charge pump adaptor assemblies.

- 11** Turn the adapter assembly over. Use an o-ring pick or similar tool remove the o-ring seal (see Figure 12).

- 12** Inspect the gerotor pocket and needle bearing located in the charge pump adapter. The needles in the needle bearing must remain intact in the bearing cage.

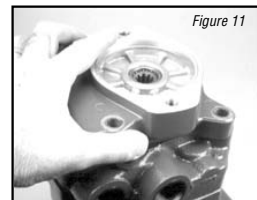
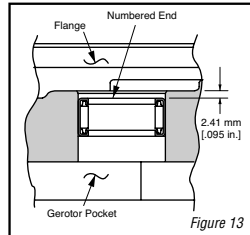

Figure 11

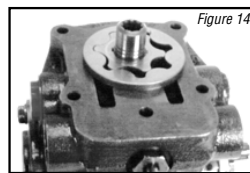

Figure 12

13 When the needle bearing assembly is replaced, the numbered end of the bearing must face toward the flange side of the adapter to the dimension as shown (see Figure 13).



14 With the charge pump adapter removed, remove the charge pump outerring and inner gerotor ring assembly (see Figure 14 and 15).



15 Charge pumps are available in two different displacements. Charge pump displacements are based on the thickness of the gerotor assembly and the depth of the pocket located in the charge pump adapter. To determine the displacement, refer to the table below.

Gerotor Pocket Depth

Displacement cm ³ /r [in ³ /r]	Depth of Pocket mm [in.]
6.9 [.42]	6.35 [.25]
13.8 [.84]	12.7 [.50]

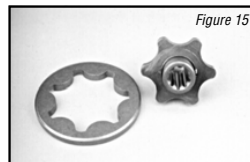

16 To separate the backplate assembly from the dowel pins in the pump housing assembly, insert two screwdrivers between backplate and housing assembly and pry upward (see Figure 16).

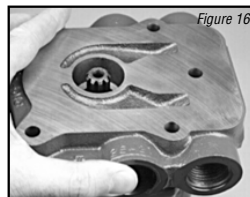

17 After separation, remove the backplate from the housing assembly.

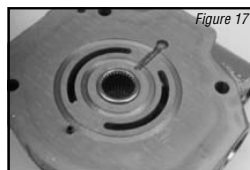

18 Turn the backplate assembly over and inspect the needle bearing. The needles in the needle bearing must remain intact in the bearing cage (see Figure 17).

19 When the needle bearing assembly is replaced, the numbered end of the bearing must face the valve plate side of the backplate to the dimension as shown (see Figure 18).

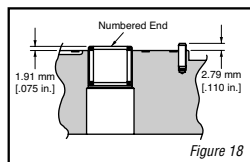

20 With the backplate removed, remove the gasket from the pump housing assembly and discard (see Figure 19).

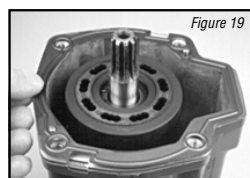

21 Remove the valve plate from the piston block assembly. Note: This valve plate may have stuck to the backplate assembly that was previously removed.

22 Valveplate directional rotation (CW or CCW) is identified by the location of the metering slots located on the face of the valve plates. Pump input rotation should always turn into the metering slots (see Figure 20). A clockwise valve plate is shown on the left and a counter clockwise valveplate is on the right.

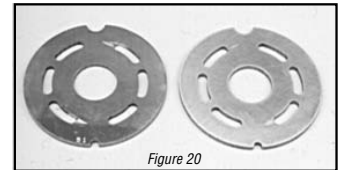

Note: Whenever pump input rotation is changed, the valve plate must be replaced along with the desired rotation charge pump adapter.

23 Remove the rotating kit assembly by carefully retaining it in the housing assembly (see Figure 21). Lift the housing and rotating kit assembly and turn over assemblies allowing the rotating kit assembly to slide down the input shaft and out of the pump housing.



24 With the rotating kit assembly removed, remove the piston assemblies, spider and spider pivot from the piston barrel. (see Figure 22).

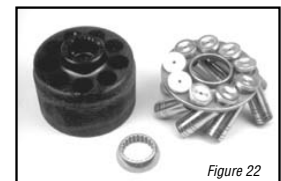

25 Inspect the piston assemblies, spider, spider pivot and piston block. The piston block assembly usually requires no further disassembly unless the pins or block spring are damaged.

26 When any excessive wear or scratches are noted on the face of the piston block, the block assembly must be replaced (see Figure 23).



DO NOT LAP THE FACE OF PISTON BLOCK ASSEMBLY.

27 To remove the input shaft assembly, use a pair of internal snap ring pliers and remove the shaft seal retaining ring from the housing assembly (see Figure 24).



76-638 REPAIR DISASSEMBLY INSTRUCTIONS

28 With the retaining ring removed, use a small press to press the shaft seal and input shaft assembly from the housing assembly.

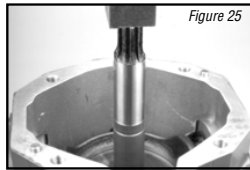

29 With the input shaft assembly removed, disassemble the assembly for inspection by removing the shaft seal, washer, retaining ring thrust washers and bearing (see Figure 26).



Note: The rear pump on tandem units uses a spacer in place of shaft seals.

30 To remove the camplate from the housing assembly, use a 9/16 in. socket or end wrench and remove the three cap screws and washers retaining the control arm cover plate assembly. Start at the cover plate with control arm (see Figure 27).

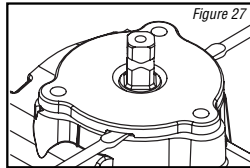

31 With the retaining cap screws removed, insert two small screwdrivers in the notches located in the cover plate assembly and pry upward. Make sure bearing cup comes off with the cover plate (see Figure 28).

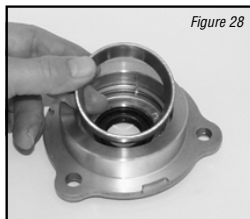

Note: The crush ring in the control arm trunnion cover does not need to be removed (see Figure 29). The only time the crush ring needs to be removed is when either the trunnion cover, the camplate assembly or the housing assembly is replaced. A shim kit is then required in the crush ring's place.

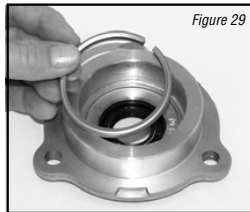

32 Reposition the pump assembly to remove opposite cover plate. The bearing cup in this cover plate is press fit and not removable. Repeat steps 30 through 31.

32b Remove the slip fit bearing on the non-control arm side of the camplate.

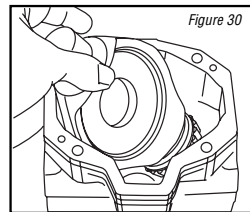

33 With housing in the upright position, slide the camplate toward the control side and lift it from the pump housing (see Figure 30).

Note: The camplate control shaft will fit out either side of the pump housing. Be sure to note on which side of the housing the control shaft protrudes before removing camplate from

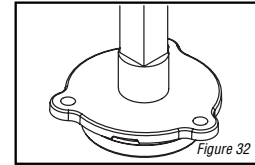
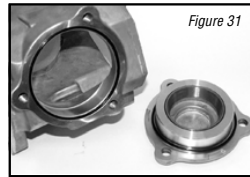

34 Use an o-ring pick or similar tool to remove the o-ring seals from the two counter-bores in the housing or the cover plates (see Figure 31).

35 To remove the control side cover plate lip seal, use a small press and press the lip seal inward (see Figure 32).

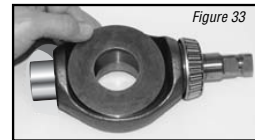

36 Remove the thrust plate from the camplate. The thrust plate is reversible and either side may face the camplate (see Figure 33).

37 Inspect the housing assembly's front needle bearing. If the needles remain in their cage and move freely, replacement usually is not required (see Figure 34).

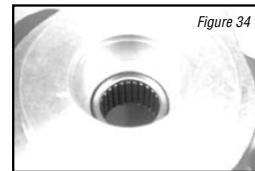

38 When the needle bearing is replaced, the numbered end of the needle bearing must face away from the housing and pressed to the dimension as shown (see Figure 35).

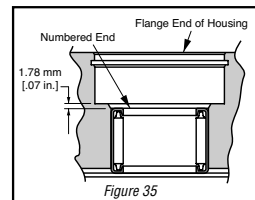

Reassembly

1 Before reassembling the pump, replace all worn and damaged parts, assemblies, seals and o-rings. Lubricate the seals and o-rings with petroleum jelly to help retain them during reassembly and to provide lubrication to the input and control shaft seals. Lubricate all finished part surfaces freely with clean hydraulic fluid to help provide start up lubrication between all rotating parts.

2 To reassemble the camplate assembly into the pump housing, tilt the camplate slightly and install the control side of the camplate through the previously noted or marked side of the housing assembly (see Figure 36).

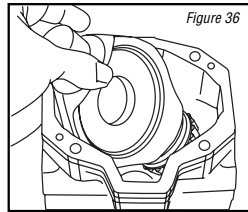

3 Lubricate the tapered bearing and reassemble it on the non-control arm side of the camplate (see Figure 37).

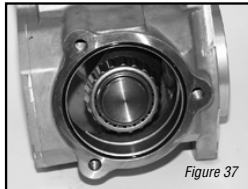

4 Lubricate and install the o-ring seal into counter-bore of housing (see Figure 37).

5 Install the trunnion cover over bearing and onto pump housing. Install the three cap screws and washers, torque screws to 39,3 Nm [29 ft-lb] (see Figure 38).

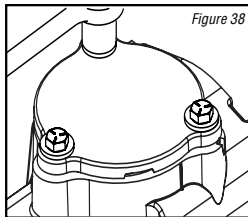

6 Lubricate and install the control arm shaft seal into the control arm cover plate. Install with the lip of the seal facing upward or to the inside of the pump (see Figure 39).

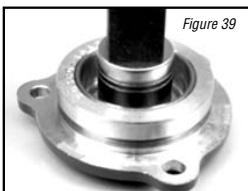

7 If the housing, trunnion covers or camplate assembly have not been replaced, the existing crush ring may be re-used. If you have replaced anyone of the above a shim kit must replace the crush ring. See Parts Information manual for number.

8 Place the bearing cup into trunnion cover over the crush ring or shims (see Figure 40).

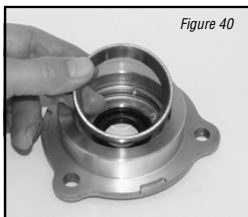

9 Lubricate and install the o-ring seal into counter-bore of housing (see Figure 41).

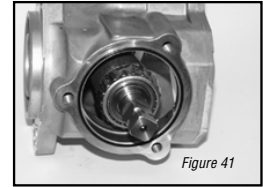

10 Install the trunnion cover over the control shaft and into the pump housing. Install the three retaining cap screws and washers, torque screws to 39,3 Nm [29 ft-lb] (see Figure 42).

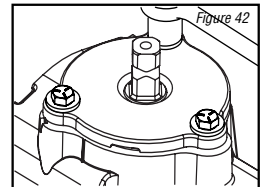

11 Using your fingers, tilt the camplate back and forth to check the trunnion bearing preload. Proper preload is achieved when the camplate has a very slight tilting resistance. The camplate must not have any or very little side clearance.

12 Reassemble the input shaft assembly by installing the thrust washer, thrust bearing, second thrust washer, retaining ring, washer and shaft seal (see Figure 43).



Note: The lip of the shaft seal must point toward the center of the input shaft.

13 Install the input shaft assembly into the housing assembly. Push the shaft seal in just far enough so you can start the shaft seal retaining ring.

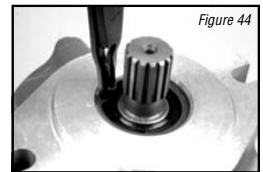

14 Use a pair of snap ring pliers to install retaining snap ring into the housing assembly (see Figure 44).

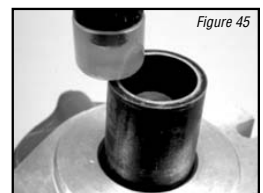

15 Use a seal driver or similar tool to press or drive the snap ring and seal into the housing assembly (see Figure 45).

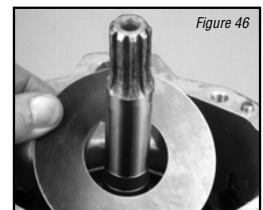

CAUTION! Press or drive inward until the snap ring snaps into the snap ring groove located in the pump housing assembly.

16 The thrust plate is reversible. Either side will fit into the camplate. In most cases if any irregularities are noted it is best to replace the thrust plate (see Figure 46).

76-638 REPAIR REASSEMBLY INSTRUCTIONS

18 Lubricate and install the thrustplate over the input shaft assembly and into the camplate. The thrustplate must rest firmly in its pocket located in the camplate.

19 Reassemble the rotating kit assembly by first aligning the splines in the pivot with the splines in the block. Install the pivot on the block assembly pins (see Figure 47).

20 Use a small socket or similar tool to help retain the pivot in the centered position. Lubricate and install the spider and piston assemblies onto the pivot and pistons into the piston block assembly (see Figure 48).

21 Hold the housing assembly in the vertical position then carefully install the rotating kit by first aligning with the splines on the input shaft. With splines aligned, install the rotating kit into the pump housing (see Figure 50). Use caution to ensure all parts are kept in their proper position.

22 With the rotating kit installed, reposition the housing assembly in the input shaft down position and install a new housing gasket (see Figure 50).

23 Lightly coat the backplate side of the valve plate with petroleum jelly for retention during assembly. Install the valve plate over the needle bearing, aligning the small slot on the outside of the valve plate with the dowel pin in the backplate (see Figure 51).

24 Carefully install the backplate assembly by aligning it with the dowel pins located in the pump housing. Use caution not to dislodge the valve plate (see Figure 54).

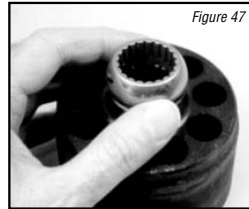

Figure 47

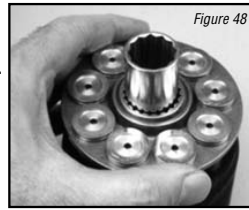

Figure 48

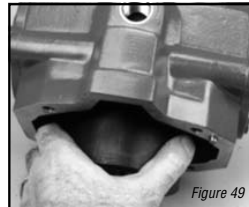

Figure 49

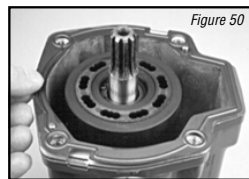

Figure 50

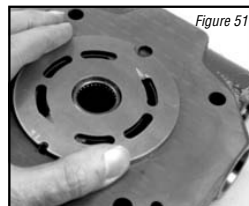

Figure 51

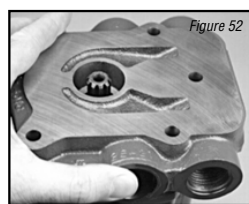

Figure 52

25 Align the spline of the gerotor's inner ring, then lubricate and install the inner ring and outer ring over the input shaft and onto the backplate assembly (see Figure 53).

Note: Before installing the charge pump adaptor plate, offset the outer ring of the gerotor as shown.

26 With the gerotor assembly installed, install new o-ring into charge pump adapter plate and place adapter onto backplate over gerotor. Retain with cap screws. Torque cap screws to 25 N•m [18.5 lbf•ft] (see Figure 54).

27 Install the two high pressure relief valves. Torque valves 128,8 to 142,4 Nm [95 to 105 lb-ft] (see Figure 55).

29 Lubricate and reassemble the bypass valve assembly. Install the bypass valve into the backplate. Torque valve to 30,5±2 Nm [22.5±1.5 lb-ft] (see Figure 56).

30 Coat the charge pressure poppet with petroleum jelly and place poppet onto spring and install into the adapter plate (see Figure 57).

31 Install the hollow charge pressure relief valve retainer into the adapter plate. Torque retainer to 6,8 to 9,5 Nm [5 to 7 lb-ft].

32 Lubricate and install the o-ring on the cover plate or gear pump. Install the cover plate or gear pump and two cap screws. Torque cap screws to 36,6 to 40 Nm [27 to 31 lb-ft].

The Model 70160 or 78162 variable displacement pump is now ready for test and reinstallation.

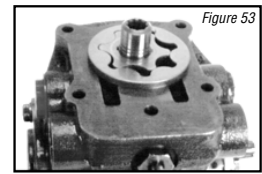

Figure 53

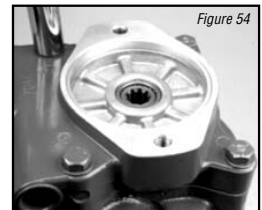

Figure 54

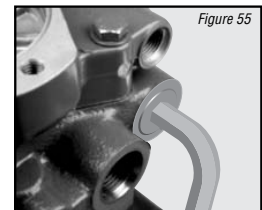

Figure 55

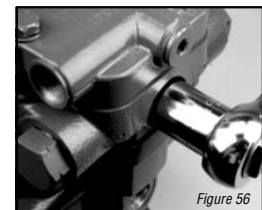

Figure 56



Figure 57

This fault - logic troubleshooting guide is a diagnostic aid in locating transmission problems.

Match the transmission symptoms with the problem statements and follow the action steps shown in the box diagrams. This will provide help in correcting minor problems eliminating unnecessary machine down time.

Following the fault - logic diagrams are diagram action comments of the action steps shown in the diagrams. Where applicable, the comment number of the statement appears in the action block of the diagrams.

Explanatory Diagram

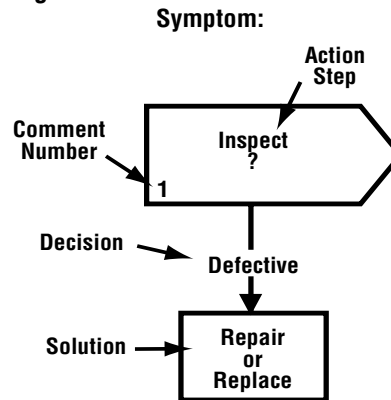

Recommended Gauge Locations

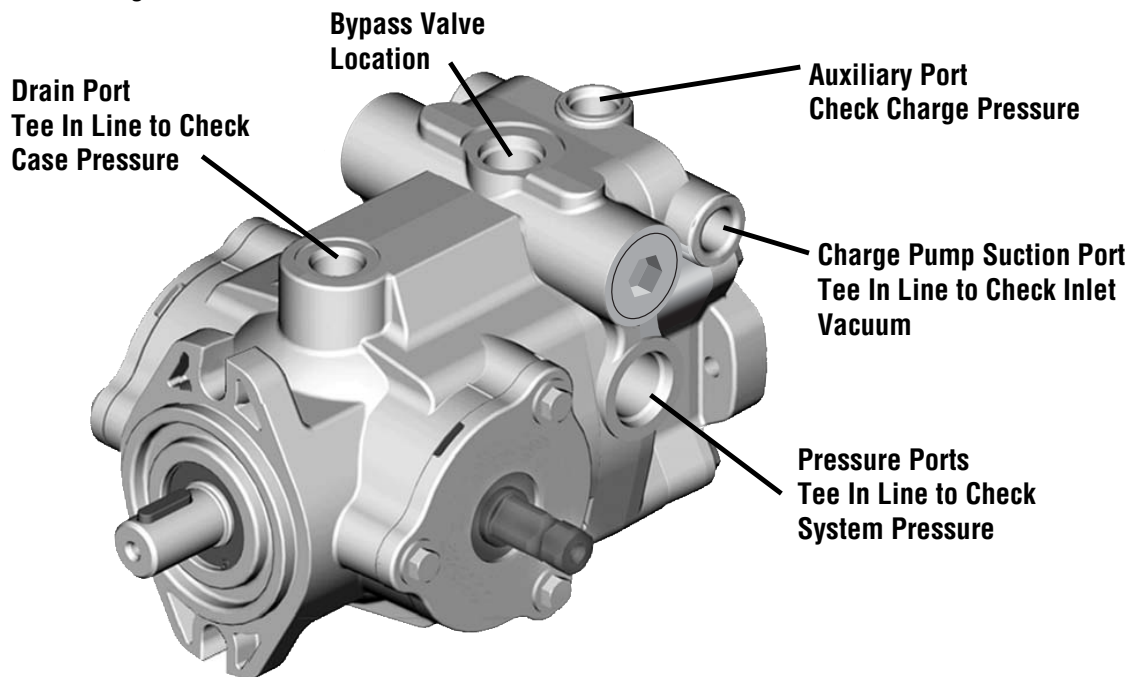
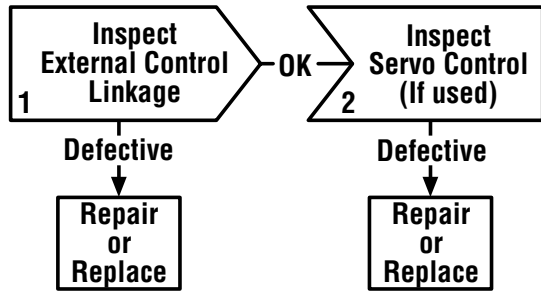

Figure 58

Gauges Recommended

- Inlet vacuum gauge: 2 bar to 1 bar [30 PSI to 30 inHg]
- System pressure gauge: 700 bar [10,000 PSI]
- Charge pressure gauge: 0 to 50 bar [0 to 600 PSI]
- Case pressure gauge: 0 to 25 bar [0 to 300 PSI]

Symptom: Neutral Difficult or Impossible to Find



Symptom: System Operating Hot

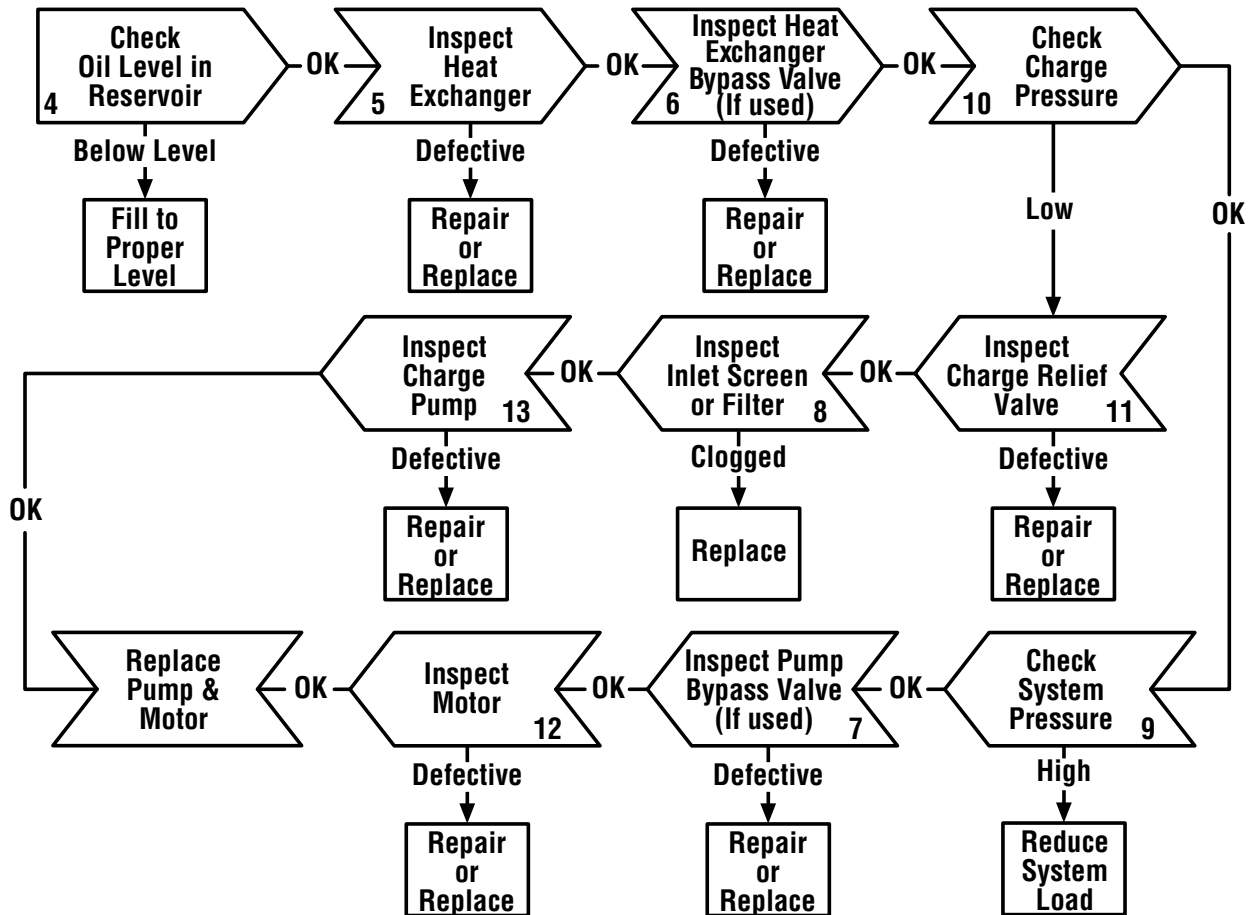

Symptom: Operates in One Direction Only

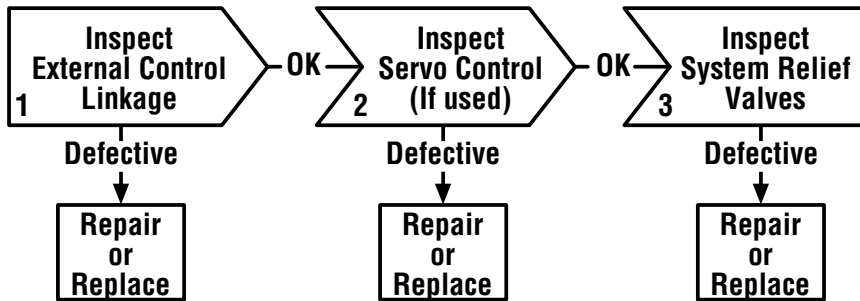

Symptom: System Response Sluggish

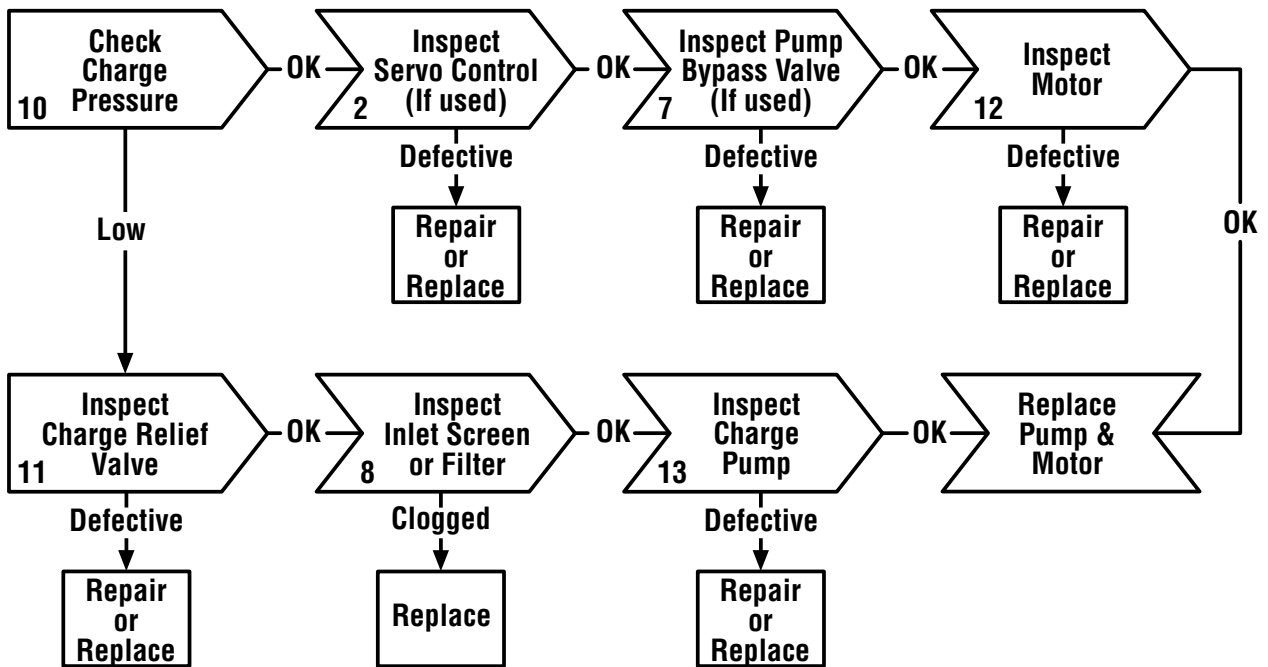

Symptom: System Will Not Operate In Either Direction

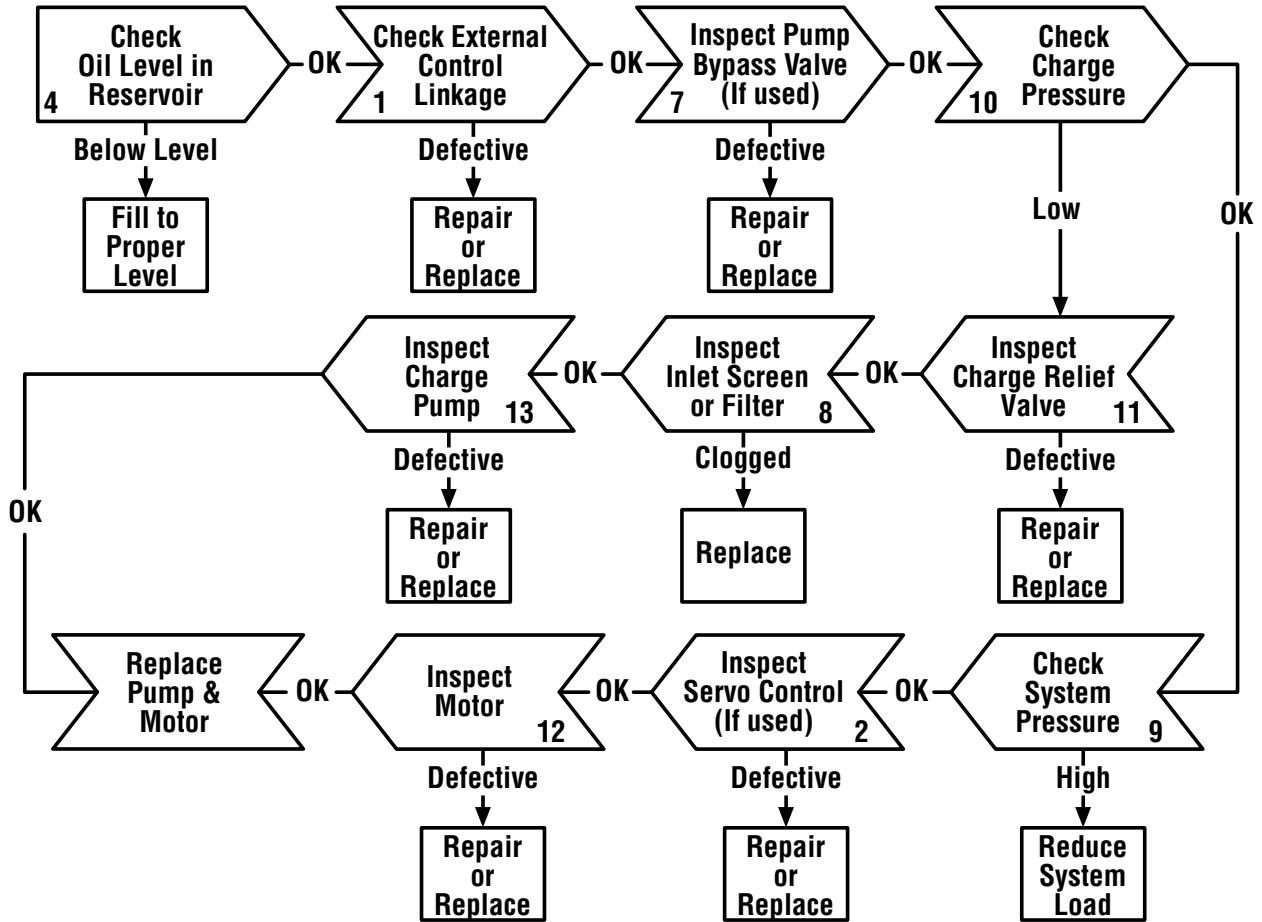

Diagram Action Step Comments

- 1 Inspect External Control Linkage for:**
 - a. misadjustment or disconnection
 - b. binding, bending or breakage
 - c. misadjusted, damaged or broken neutral return spring
- 2 Inspect Servo Control Valve for: (if used)**
 - a. proper inlet pressure
 - b. misadjusted, damaged or broken neutral return spring
 - c. galled or stuck control spool
 - d. galled or stuck servo piston
- 3 Inspect System Relief Valves* for:**
 - a. improper pressure relief setting
 - b. damaged or broken spring
 - c. valve held off seat
 - d. damaged valve seat
- 4 Check Oil Level in Reservoir:**
 - a. consult owner/operators manual for the proper type fluid and level
- 5 Inspect Heat Exchanger for:**
 - a. obstructed air flow (air cooled)
 - b. obstructed water flow (water cooled)
 - c. improper plumbing (inlet to outlet)
 - d. obstructed fluid flow
- 6 Inspect Heat Exchanger Bypass Valve for: (if used)**
 - a. improper pressure adjustment
 - b. stuck or broken valve
- 7 Inspect Pump Bypass Valve for: (if used)**
 - a. held in a partial or full open position
- 8 Inspect Inlet Screen or Filter for:**
 - a. plugged or clogged screen or filter element
 - b. obstructed inlet or outlet
 - c. open inlet to charge pump
- 9 Check System Pressure:**
 - a. See figure 60 for location of pressure gauge installation.
 - b. consult owner/operators manual for maximum system relief valve settings
- 10 Check Charge Pressure:**
 - a. See figure 60 for location of pressure gauge installation.
 - b. consult owner/operators manual for maximum charge relief valve settings

- 11 Inspect Charge Relief Valve for:**
 - a. improper charge relief pressure setting *
 - b. damaged or broken spring
 - c. poppet valve held off seat

- 12 Inspect Motor for:**
 - a. disconnected coupling

- 13 Inspect Charge Pump for:**
 - a. broken or missing drive key
 - b. damaged or missing o-ring
 - c. excessive gerotor clearance
 - d. galled or broken gerotor set

*** System/Charge Relief Valve Pressure Settings for Eaton's Variable Displacement Controlled Piston Pumps**

Inlet Vacuum	6 inHg max.
Case Pressure	25 PSI maximum
Charge Pressure	100 to 150 PSI Standard 200 to 250 PSI Optional 250 to 300 PSI Optional
System Pressure	5000 PSI maximum 3000 PSI continuous

The high pressure relief valves are all factory preset and cannot be readjusted.

The pressure setting and assembly number is stamped on each high pressure relief valve cartridge.

Valve Identification Example:

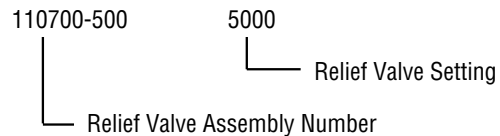

76-638 START-UP PROCEDURE

When starting a new or rebuilt transmission system, it is extremely important to follow the start-up procedure. It prevents the chance of damaging the unit which might occur if the system was not properly purged of air before start-up.

- 1 After the transmission components have been properly installed, fill the pump housing at least half full with filtered system oil. Connect all hydraulic lines and check to be sure they are tight.
- 2 Install and adjust all control linkage.
- 3 Fill the reservoir with an approved oil that has been filtered through a 10 micron filter. Refer to Eaton Hydraulics Technical Data Sheet number 3-401 titled Hydraulic Fluid Recommendations.
- 4 For Gasoline engines or L.P. engines remove the coil wire and turn the engine over for 15 seconds. For Diesel engines shut off the fuel flow to the injectors and turn the engine over for 15 seconds.
- 5 Replace the coil wire or return the fuel flow to the injectors. Place the transmission unit in the neutral position, start the engine and run it at a low idle. The charge pump should immediately pick up oil and fill the system. If there is no indication of fill in 30 seconds, stop the engine and determine the cause.

- 6 After the system starts to show signs of fill, slowly move pump camplate to a slight cam angle. Continue to operate system slowly with no load on motors until system responds fully.
- 7 Check fluid level in the reservoir and refill if necessary to the proper level with an approved filtered oil.
- 8 Check all line connections for leaks and tighten if necessary.

The machine is now ready to be put into operation.

Frequent filter changes are recommended for the first two changes after placing the machine back into operation. Change the first filter in 3-5 hours and the second in approximately 50 hours. Routinely scheduled filter changes are recommended for maximum life of the hydraulic system.

76-539 MOTOR DRAWING

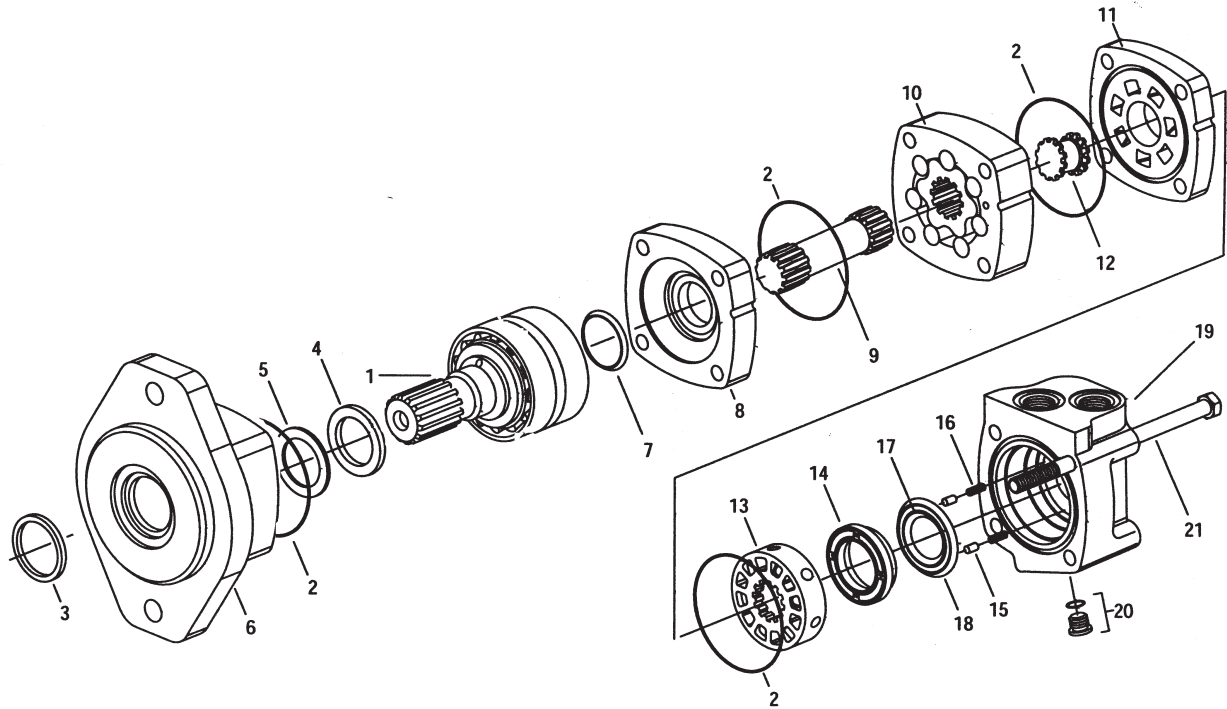

REF#	PART#	DESCRIPTION	QUANTITY
1	76-539-01	Shaft and Bearing Kit	1
2*		Seal	4
3*		Exclusion Seal	1
4*		Shaft Seal	1
5*		Back-up Ring	1
6	76-539-02	Bearing Housing SAE A	1
7*		Shaft Face Seal	1
8	30-101-03	Wear Plate	1
9	76-539-03	Main Drive	1
10	76-539-04	Geroler	1
11	30-101-06	Valve Plate	1
12	14-207	Valve Drive	1
13	14-208	Valve	1
14	30-101-07	Balance Ring	1
15	14-210	Balance Ring Pin	2
16	14-209	Compression Spring	2
17*		Inner Face Seal	1
18*		Outer Face Seal	1
19	30-101-08	Valve Housing	1
20	30-101-09	Plug Assembly	1
*		O-ring	1
21	76-539-05	Cap Screw	4
*	30-101-11	Seal Kit	1

Disassembly

Cleanliness is extremely important when repairing a hydraulic motor. Work in a clean area. Before disconnecting the lines, clean the port area of the motor thoroughly. Use a wire brush to remove foreign material and debris from around the exterior joints of the motor. Check the shaft and key slot, remove all nicks, burrs or sharp edges that might damage the bearing housing seals when installing the shaft and bearing assembly. Before starting the disassembly procedures, drain the oil from inside the motor.

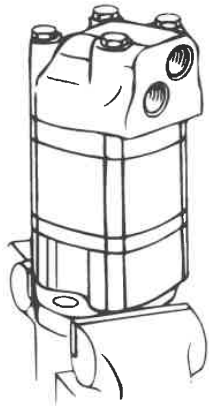

Figure 1

1 Place the motor in a vise with the output shaft down. Clamp across the mounting flange of the motor not the housing. Excessive clamping pressure will cause distortion. When clamping, use some protective device on the vise, such as special soft jaws, pieces of hard rubber or board.

Although not all drawings show the motor in a vise, we recommend that you keep the motor in the vise during disassembly and reassembly. Follow the clamping procedures explained throughout the manual.

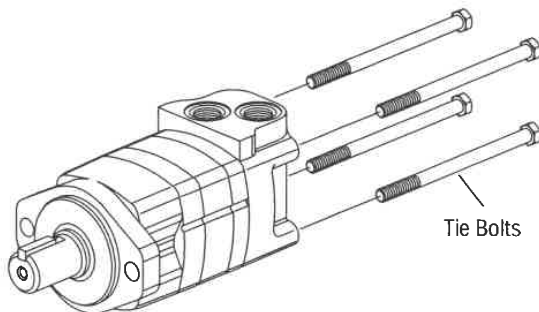

Figure 2

2 Remove 4 bolts from motor.

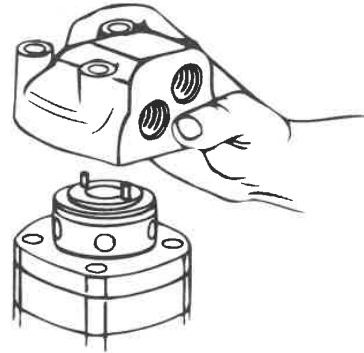

Figure 3

3 Lift valve housing straight up. If done carefully the pins, springs, balance ring assembly, and valve will remain on the valve plate.

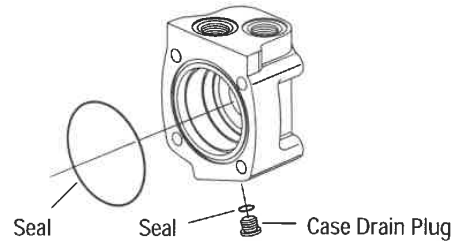

Figure 4

4 Carefully remove 76,0 [3.00] diameter seal from valve housing.

5 Remove case drain plug—with seal, from valve housing.

6 Remove 2 pins and 2 springs from balance ring assembly, see Figure 5.

Disassembly

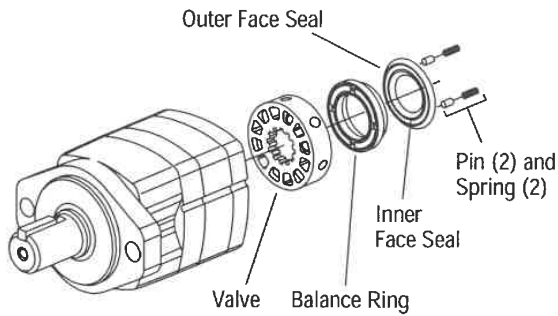

Figure 5

- 7 Remove balance ring assembly.
- 8 Remove inner and outer face seals from balance ring.
- 9 Remove the valve.

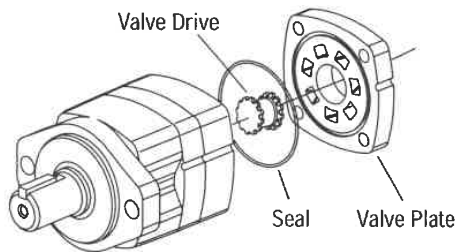

Figure 6

- 10 Remove the valve plate.
- 11 Remove the 76,0 [3.00] diameter seal from valve plate.
- 12 Remove the valve drive.

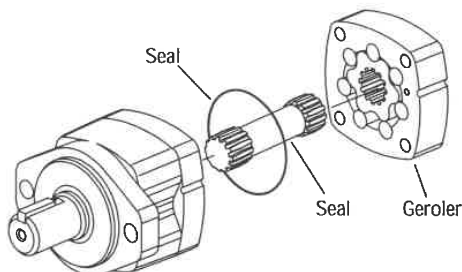

Figure 7

- 13 Remove the Geroler. Be sure to retain the rollers in the outer ring if they are loose.
- 14 Remove the drive.

- 15 Remove the 76,0 [3.00] diameter seal from wear plate, see Figure 7.

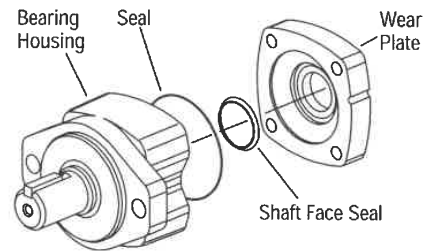

Figure 8

- 16 Remove the wear plate.
- 17 Remove the shaft face seal from the wear plate.
- 18 Remove the 76,0 [3.00] diameter seal from bearing housing.

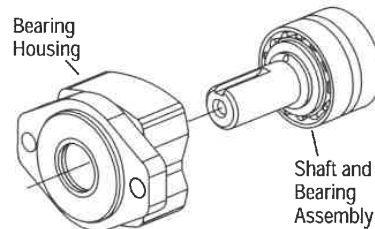

Figure 9

- 19 You may need a press to remove shaft and bearing assembly from bearing housing. (Key must be removed before removing shaft.)

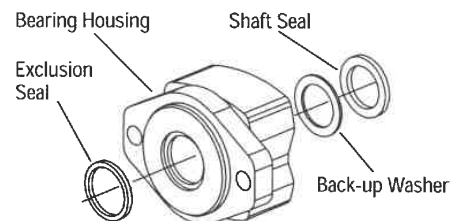

Figure 10

- 20 Use a small screwdriver to remove shaft seal, back-up washer and exclusion seal from bearing housing, see Figure 10. Do not damage bore of housing.

Note: Individual parts of shaft and bearing assembly are not sold separately. Replace as a unit.

Reassembly

Check all mating surfaces. Replace any parts that have scratches or burrs that could cause leakage. Clean all metal parts in clean solvent. Blow dry with air. Do not wipe dry with cloth or paper towel because lint or other matter can get in the hydraulic system and cause damage. Do not use a coarse grit or try to file or grind these parts. Check around the keyway and chamfered area of the shaft for burrs, nicks or sharp edges that can damage the seals when reassembling the bearing housing.

Note: Lubricate all seals (prior to installation) with petroleum jelly such as Vaseline. Use new seals when reassembling this motor. Refer to parts list (6-129) for proper seal kit number.

21 Use a press to install exclusion seal in outer bore of bearing housing. Lip of seal must face outward. See Figure 11. If a press is not available use a plastic or rubber hammer, being careful not to damage or cock seal in the bore.

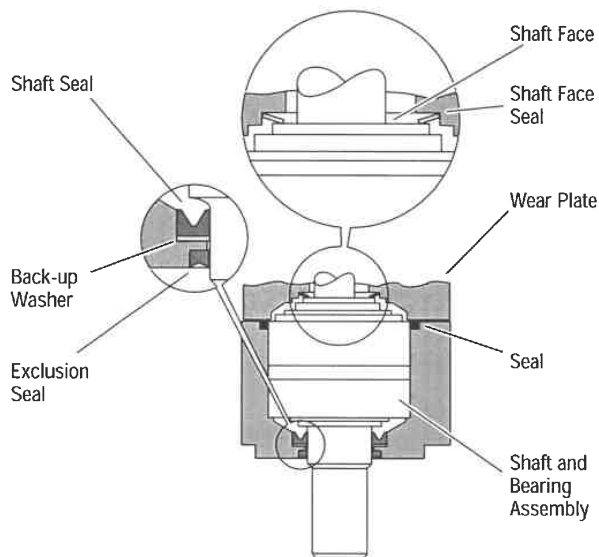

Figure 11

22 Place back-up washer into seal bore. Place shaft seal onto installation tool (600496) and press seal into seal bore of the housing.

23 Clamp housing in vise, see Figure 1.

24 Place protective bullet (see note below) over shaft. Apply petroleum jelly to inside diameter of dust and shaft seal. You may need a press to install shaft and bearing assembly. Do not distort shaft seal. Damage to this seal will cause leakage.

Note: Bullet (600465), for 1 inch dia. shafts, available— by special order. Use tape over other shafts to prevent cutting the seals.

25 Apply petroleum jelly to the 76,0 [3.00] diameter seal. Install seal into the bearing housing.

26 Alignment studs can be very helpful in reassembly of the motor. See special tool listing page 2. If you use studs, install 2 studs diagonally opposed in the bearing housing.

27 Install the shaft face seal in the wear plate as shown in Figure 11. Do not distort seal.

28 Install the wear plate, see Figure 11.

29 Apply a light film of petroleum jelly to the 76,0 [3.00] diameter seal and install seal in the wear plate.

30 Install the drive into the output shaft.

31 Align the notch on the outside of the Geroler with the notch on the wear plate. Install the Geroler against the wear plate. Be sure to retain the rollers in the outer ring if they are loose.

32 Install the valve drive in the Geroler.

Note: Installation at this time involves 3 steps in the timing of the motor. Timing determines the direction of rotation of the output shaft. Timing parts include:

1. Geroler
2. Valve Drive
3. Valve Plate
4. Valve

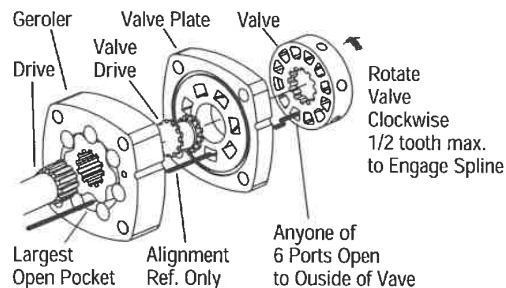

Figure 12 Timing Alignment

Timing Step # 1 — Locate the largest open pocket in the Geroler and mark it on the outside edge of the Geroler.

33 Apply a light film of petroleum jelly to the 76,0 [3.00] diameter seal. Install seal in groove of valve plate.

Reassembly

34 Align the notch on the outside of the valve plate with the notch on the Geroler as shown in Figure 12.

Timing Step # 2 — Locate the slot opening in the valve plate which is in line with the largest open pocket of the Geroler. Install the valve by

Timing Step # 3 — Locate any one of the side openings of the valve and align this opening with the open slot of the valve plate that is in line with the largest open pocket of the Geroler. Install the valve by rotating it clockwise until the spine teeth engage (1/2 spine tooth max.). This will provide the proper rotation when pressurized as shown in Figure 13.

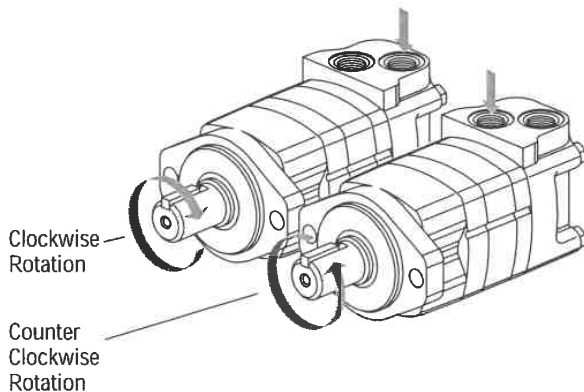

Figure 13

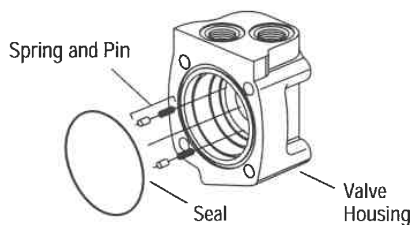

Figure 14

35 Install 2 springs and 2 pins in the holes located in the bore of the valve housing, as shown in Figure 14.

36 Apply a light film of petroleum jelly to the 76,0 [3.00] diameter seal. Install seal in the valve housing.

37 Apply petroleum jelly to inner and outer face seals. Install seals on balance ring as shown in Figure 15.

Important: Install face seals in the positions shown in Figure 15, or the motor will not operate properly. Do not force or bend the face seals. Any damage to these seals will affect the operation of the motor.

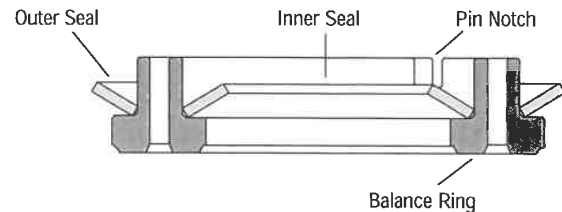

Figure 15

38 Align pin notches in balance ring with pins in bore of valve housing. Install balance ring assembly in valve housing.

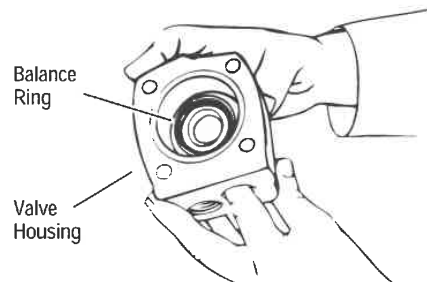

Figure 16

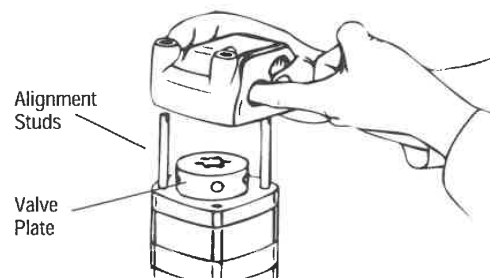

Figure 17

39 Insert your finger through port of valve housing. Apply pressure to side of balance ring as shown in Figure 16. Hold ring in position until valve housing is in place against valve plate (see Figure 17).

Note: After installing the valve housing on the valve plate check for proper placement. Push down on the valve housing. You should get a slight spring action.

Reassembly

40 Install tie bolts. If you use alignment Studs, install 2 bolts opposite the studs. Finger tighten the bolts. Remove the alignment studs and replace with the two remaining bolts. Torque all four bolts alternately to 50 Nm [450 lb-in].

41 Install seal on case drain plug then install in valve housing. Torque to 6 Nm [50 lb-in.]

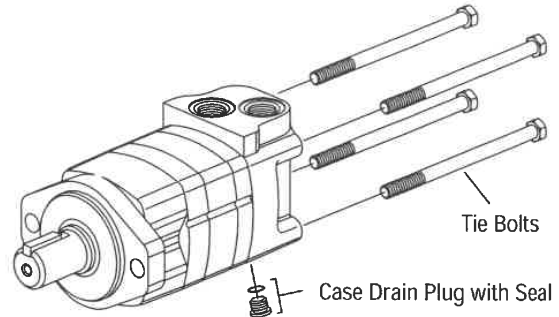

Figure 18

Wheel Motor

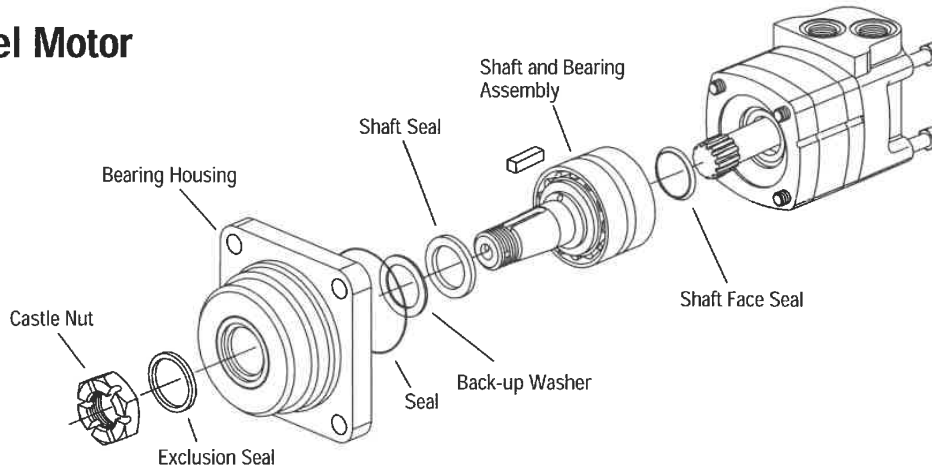

Figure 19

On wheel motors, a different bearing housing is used, see Figure 19. Other than this the parts are the same as the standard motor and the same disassembly and reassembly procedures apply.

Wheel Motor with Seal Guard

Installation of Seal Guard:

After completing assembly of the shaft and bearing assembly into the bearing housing, press the seal guard onto the shaft with a tool that will provide an even push over the seal. This tool must bottom out against the bearing housing and provide a 4,5 mm [.177 inch] stop for the seal guard.

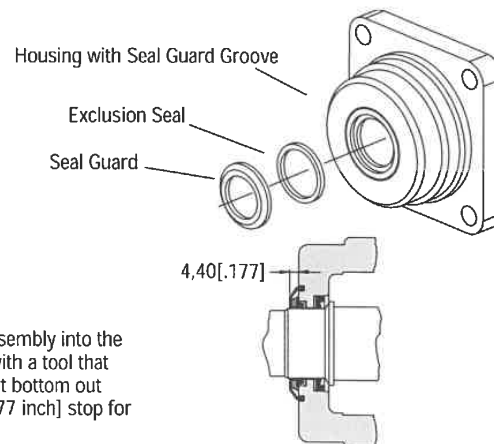



2000 Series Disc Valve Motors

Bearingless Motor

This motor is the same as the standard motor without the shaft/bearing assembly, and bearing housing. The mounting flange replaces the bearing housing, see Figure 20. Follow same disassembly and reassembly procedures as rear section of standard motor.

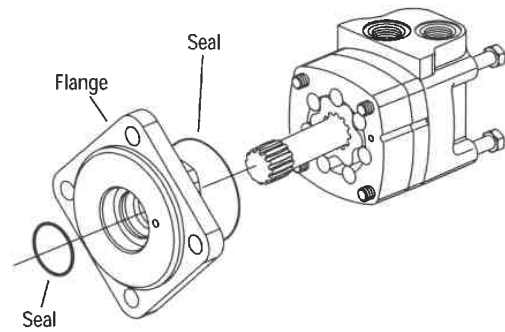

Figure 20

Service

Disassembly Reassembly Shuttle Valve Option

Disassembly of shuttle valve option, this valve is located in the valve housing. Clean and inspect shuttle valve parts and reassemble with new seals, torque plugs to 8-11 Nm [75-100 lb-in].

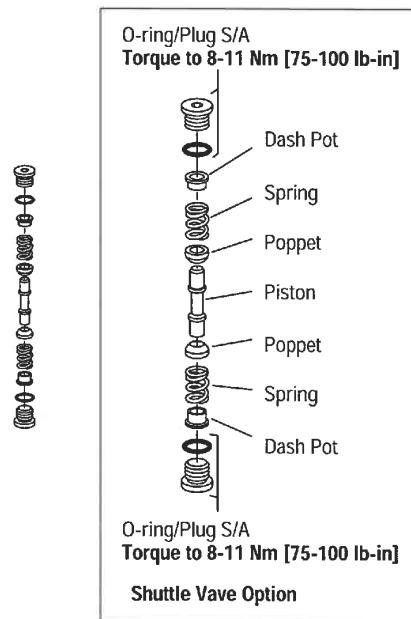
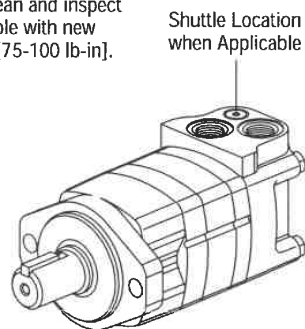

Figure 21

2000 Series Disc Valve Motors

Reassembly — Speed Sensor

1 Rotate the motor shaft until a (gear/target) tooth is centered in the speed sensor port. If this is not done, the sensor may be damaged during the operation of the motor.

2 Make sure the lock nut and its threads are clean and dry for the proper torque. Position the lock nut against the alignment nut as shown in Figure 22.

3 Move the washer and the o-ring up against the speed sensor body threads as shown in Figure 22.

4 By hand, lightly thread the speed sensor body into the housing until the sensor touches against the motor (gear/target) tooth. **Do not force the sensor against the (gear/target) tooth, damage may occur.** Make sure the o-ring or the washer do not touch the housing — see Figure 23.

5 Turn the speed sensor body out one quarter turn (CCW) plus the additional amount (CCW) needed to make the alignment notches perpendicular to the motor shaft centerline ($90^\circ \pm 5$ degrees from the motor shaft centerline — Figure 24 and 25).

6 Maintain the speed sensor body alignment (Figure 25), and tighten the lock nut to 8,5-14 Nm [75-125 lb-in.] (torque values are for clean dry threads).

7 Check the speed sensor body for correct alignment (Figure 25), reinstall the sensor if it is not correct.

Speed Sensor Installation

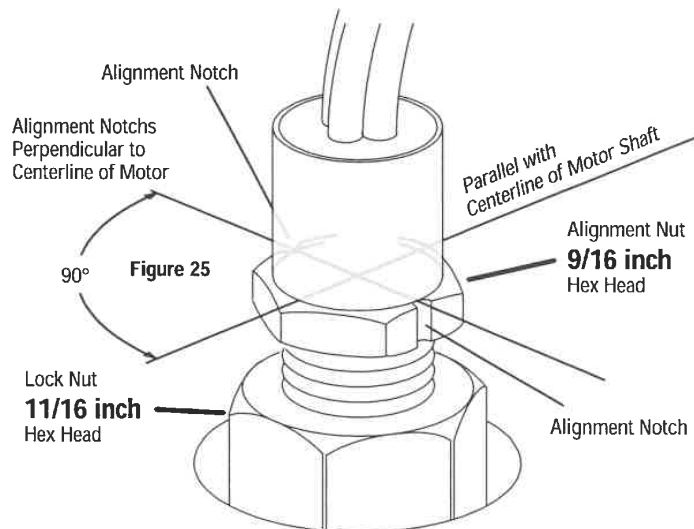
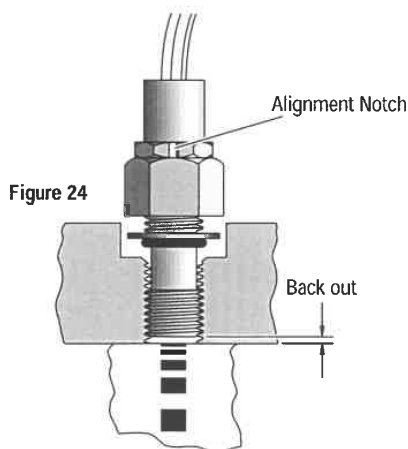
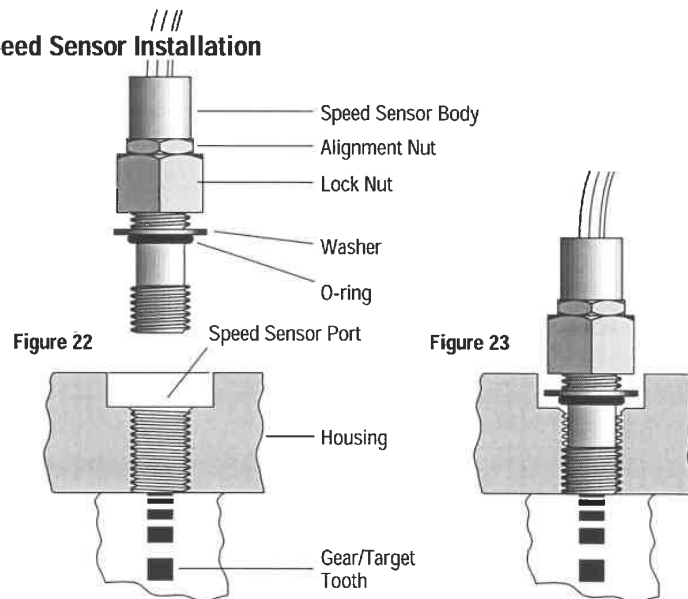

76-559 POWER STEERING DRAWING

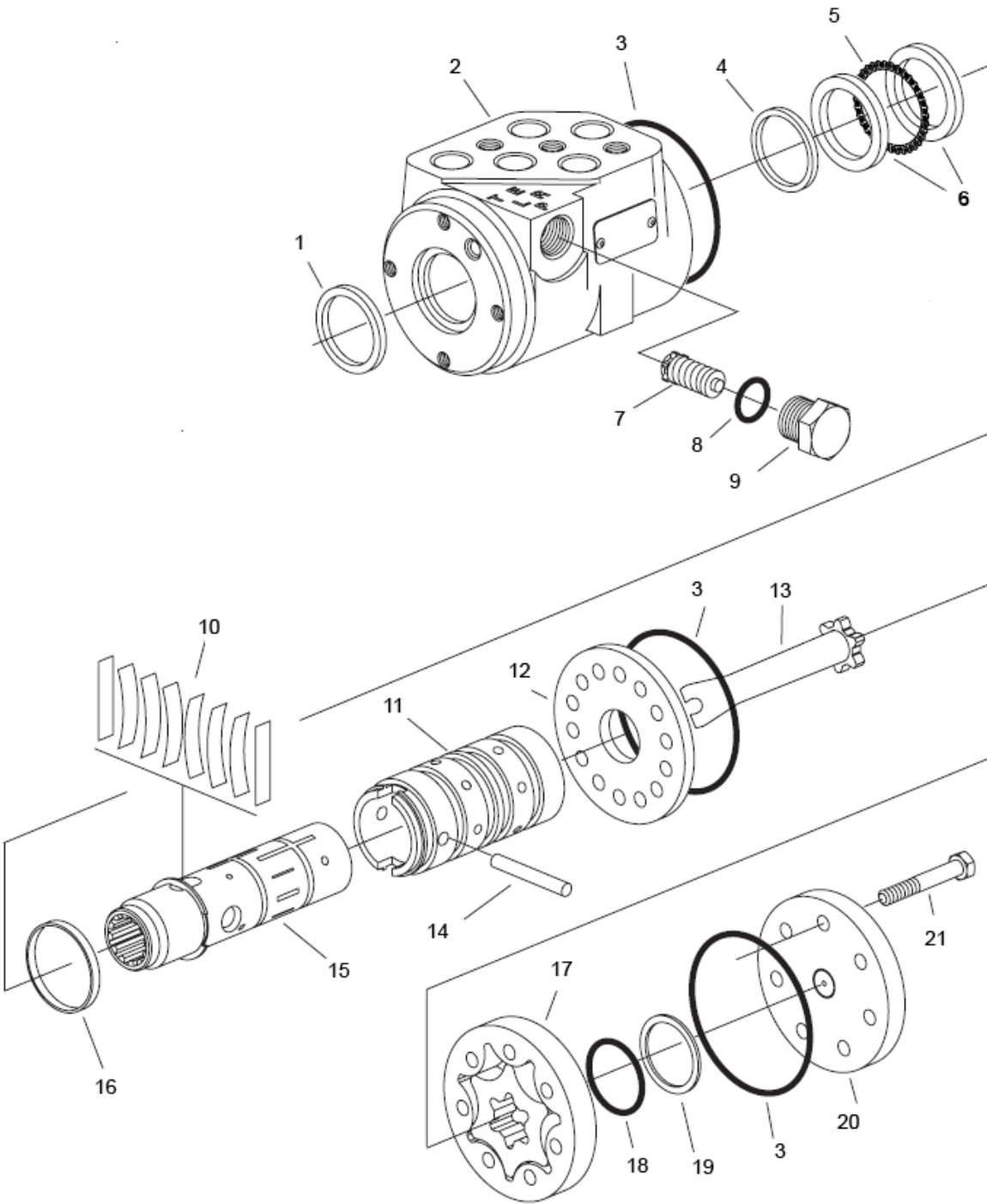

Parts

76-559 POWER STEERING PARTS LIST

REF#	PART#	DESCRIPTION	QUANTITY
1	10-576-04	Dust Seal	1
2		Housing	1
3**		O-Ring Seal	3
4**		Quad Seal	1
5	10-576-03	Thrust Bearing	1
6	10-576-02	Bearing Race	2
7		Manual Steering Relief Valve	1
8**		O-ring	1
9		Plug	1
10‡		Standard Torque Centering Springs	1
11		Sleeve	1
12	15-301-06	Wear Plate	1
13	10-576-01	Drive	1
14	15-301-08	Drive Pin	1
15		Spool	1
16‡		Spring Retaining Ring	1
17	76-559-01	Gerotor	1
18**		O-Ring	1
19**		Seal Ring	1
20	15-301-03	End Cap	1
21	76-559-02	Cap Screw	7
**	15-301-01	Seal Kit	1
‡	15-301-15	Centering Spring Kit	1

76-559 ORBITROL SPECIFICATIONS

Inlet Relief Valve Setting	1020 psi (70 bar)
Nominal Flow	3 gpm (11 lpm)
Displacement	6.10 cu. in/ R (100 cu cm/R)
Check Valve for Manual Steering	Yes
Inlet Pressure Rating	2030 psi (140 bar)
Return Pressure Rating	145 psi (10 bar) Maximum
Fluid	SAE 10W-40 API Service SJ or higher Motor Oil
Ports	9/16 - 18 SAE O-Ring 4 Ports

76-559 REPAIR DISASSEMBLY INSTRUCTIONS

Disassembly

Cleanliness is extremely important when repairing hydraulic Steering Control Units (SCU). Work in a clean area. Before disconnecting the hydraulic lines, clean the port area of the SCU. Before disassembly, drain the oil, then plug the ports and thoroughly clean the exterior of the SCU. During repairs, always protect machined surfaces.

1. Remove the seven cap screws and disassemble the SCU as shown in figure 1.

2. Remove the plug and manual steering check as shown in figure 1.
Note: The manual steering check may be a check ball or a check/relief valve.
3. Slide the spool and sleeve from the housing, see figure 2.
4. Remove the thrust bearing and bearing races.
5. Remove the quad seal.

6. Using a small blade screwdriver, carefully pry the dust seal from the housing. Important: Do not damage the dust seal seat.
7. Remove the pin that holds the spool and sleeve together, see figure 3.
8. Carefully slide the spool out of the sleeve. The springs and retaining ring will stay with the spool as it's removed.

9. Remove the retaining ring and springs. Caution: The centering springs are under tension; remove the retaining ring carefully.

Figure 1

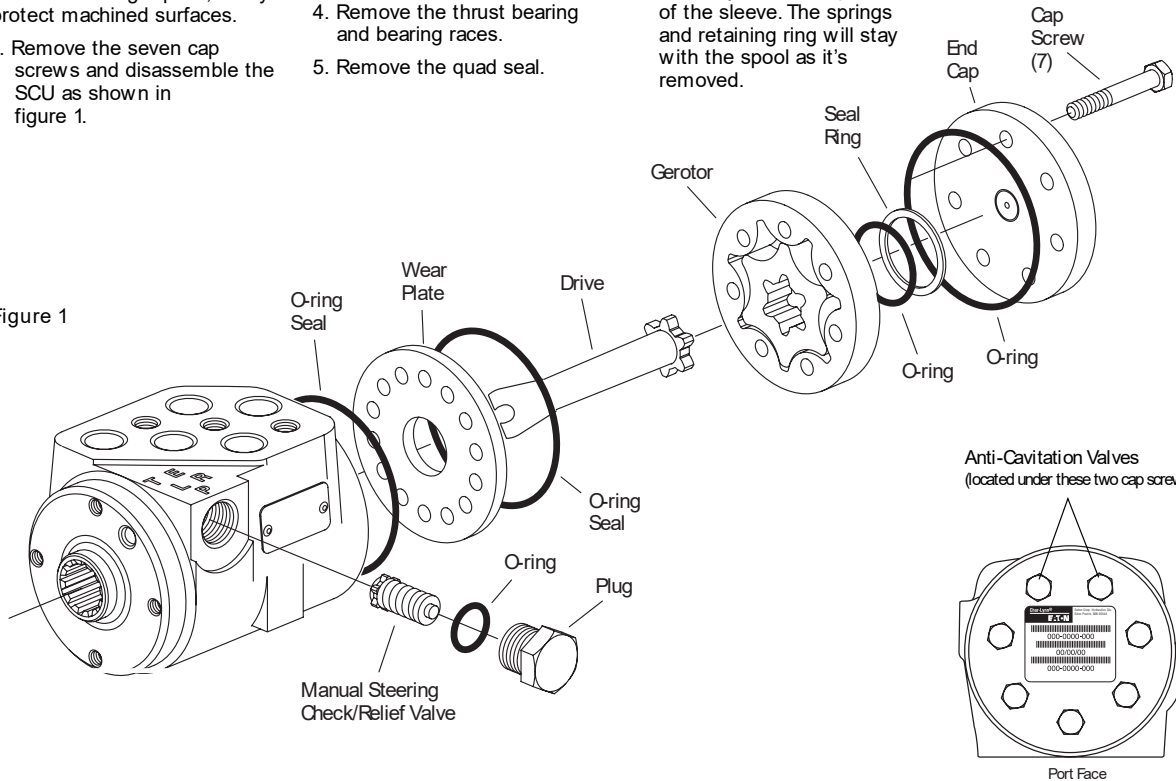
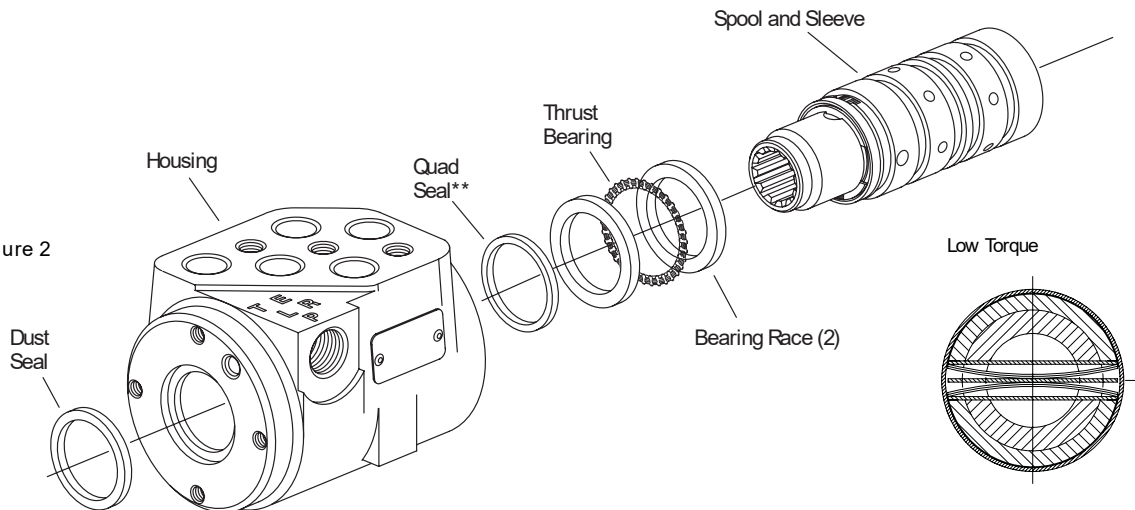

Figure 2



Reassembly

Check all mating surfaces. Replace any parts with scratches or burrs that could cause leakage. Wash all metal parts in clean solvent. Blow them dry with pressurized air. Do not wipe parts dry with paper towels or cloth as lint in a hydraulic system will cause damage.

Note: Always use new seals when reassembling hydraulic steering control units. Refer to page 5 for seal kit part numbers.

Important: During reassembly lubricate the new seals with a petroleum jelly such as Vaseline®. Also lubricate machined surfaces and bearings with clean hydraulic fluid.

10. Install the quad seal (see page 12 for 2-piece seal installations):

- Put one of the bearing races and sleeve into the housing.
- Together, the housing and bearing race create a groove into which the quad seal will be installed.
- Hold the bearing race tightly against the input end of the housing by pushing on the gerotor end of the sleeve.
- Fit the quad seal into its seat through the input end of the housing. Be sure the seal is not twisted.
- Remove the sleeve and bearing race.

11. Lubricate and install the dust seal (see Figure 4 for correct seal orientation).

Figure 4

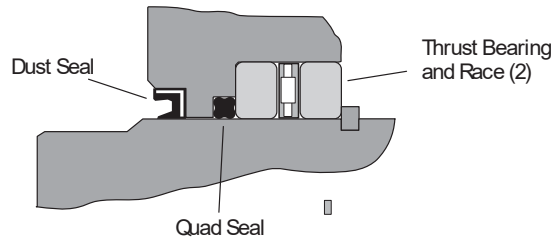
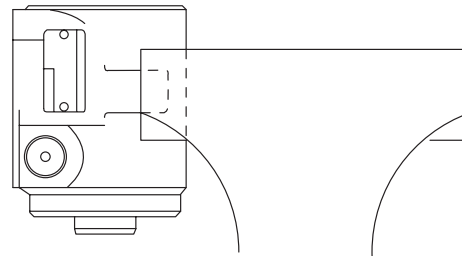

Figure 5



12. Install the centering springs in the spool. It is best to install the two flat pieces first. Next, install the curved pieces, three at a time.
13. Fit the retaining ring over the centering springs.
14. Apply a light coating of clean hydraulic fluid to the spool and slide it into the sleeve. Be sure the centering springs fit into the notches in the sleeve.

15. Install the drive, be sure the slot in the drive engages the pin.
16. Install the pin (see Figure 3).
17. Apply a light coating of petroleum jelly to the inner edge of the dust and quad seals.
18. Put the thrust bearing and races into the housing. The thrust bearing goes between the two races (see Figure 2).



Figure 3

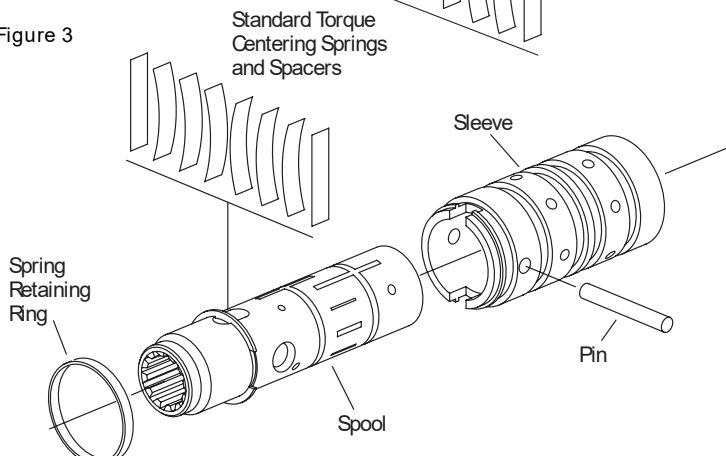

19. Apply a light coating of clean hydraulic fluid to the spool and sleeve assembly and slide it into the housing. Important: Do not damage the dust or quad seals..
20. Clamp the housing in a vise as shown in Figure 5. Use just enough clamping force to hold the housing securely.
21. Lubricate and install a new o-ring seal in the groove in the housing.
22. Install the wear plate and align the holes in the wear plate with threaded holes in the housing. Note: The holes in the wear plate are symmetrical.
23. Lubricate and install a new o-ring seal in the groove in the wear plate.
24. Install the gerotor and align the screw holes.
25. Lubricate and install a new o-ring seal in the groove in the gerotor ring.
26. Lubricate and install a new o-ring and seal ring in the groove in the gerotor star.
27. Install end cap and seven cap screws. Tighten cap screws, in a crisscross pattern, to 16 -18 Nm [140 -160 lb-in].
28. Remove the SCU from the vise.
29. Install the relief valve/check or check ball and plug. Use a new o-ring and tighten the plug to 17 Nm [150 lb-in].

76-559 REPAIR INSTRUCTIONS

2-Piece Shaft Seal Installation

For installation of
O-Ring 4999650-001 and
Seal 4998312-001

1. Place housing on a flat work area as shown in figure 13.
2. Lubricate seal and o-ring with hydraulic oil before installation.
3. Align sleeve with housing bore (figure 13).
4. Insert sleeve into housing bore (figure 14).
5. Place o-ring on plunger (figure 15).
6. Align seal with plunger cross section "L" shape of seal should be upside down (figure 16).
7. Push seal onto plunger. Lip of seal should be between o-ring and plunger. No gap should exist between o-ring and seal (figure 17).
8. Align plunger into sleeve until it bottoms out, rotate 1/4 turn (figure 19).
9. While holding sleeve in housing, withdraw plunger.
10. Withdraw sleeve.
11. Inspect seal installation. Seal and o-ring must both be within shaft seal counter bore of housing.

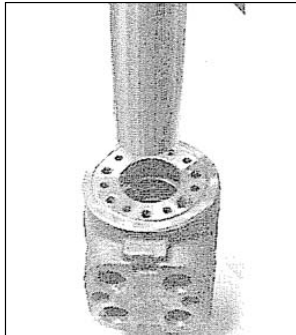
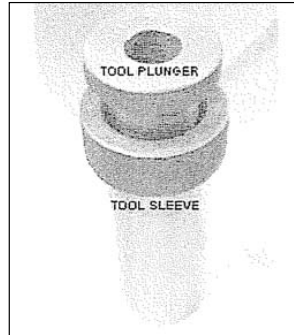

Figure 13



Tool No. 600801-001

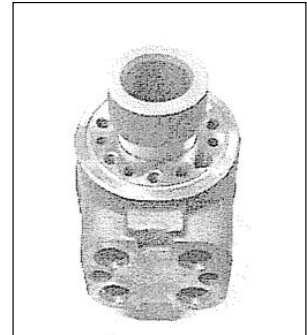

Figure 14



Figure 15



Figure 16



Figure 17

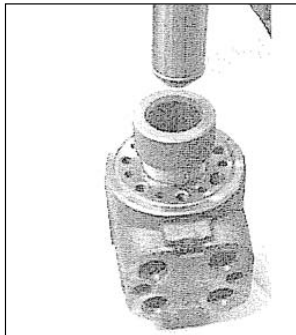

Figure 18

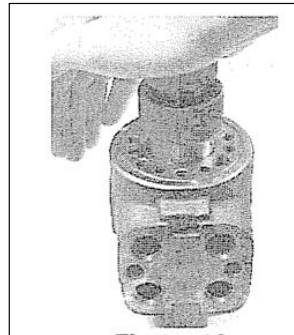

Figure 19

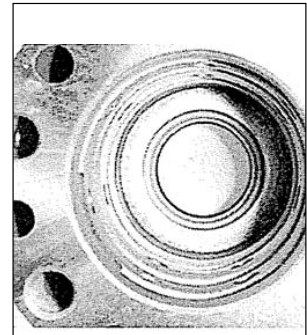
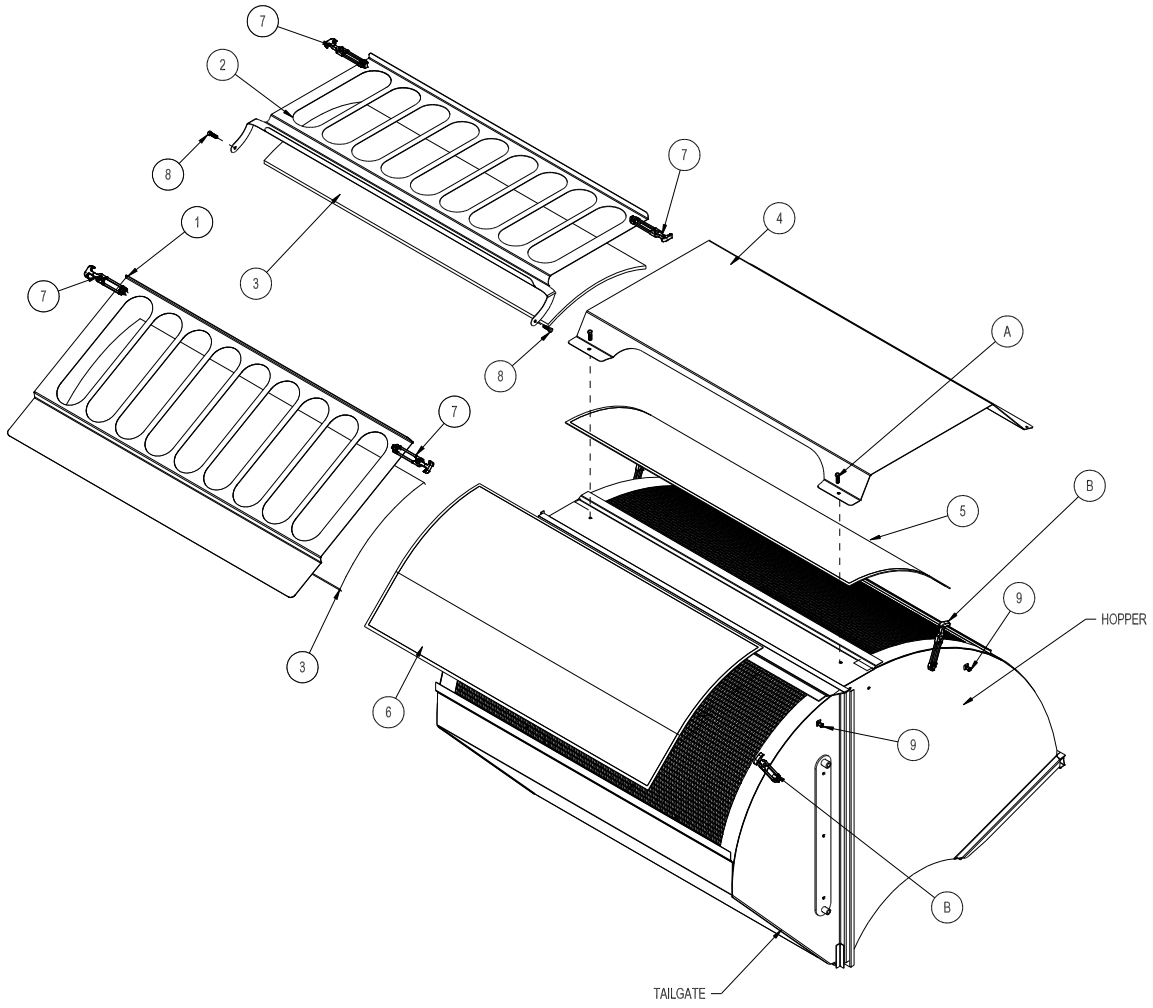

Figure 20



76-751 DUST/DIRT FILTRATION SYSTEM



76-751 DUST/DIRT FILTRATION SYSTEM

REF#	PART#	DESCRIPTION	QUANTITY
1	76-622	Tailgate Screen Cover	1
2	76-623	Top Filter Cover	1
3	76-624	Hog Hair Filter (20 x 58)	2
4	76-263	Hopper Screen Cover (Remove)	1
5	76-261	Hopper Screen (Remove)	1
6	76-262	Tailgate Screen (Remove)	1
7*	15-437-02	Latch	4
	HSM-10-32-100	Hex Bolt, #10 - 32 x 1	8
	HNFL-10-32	Flange Whiz-loc Nut, #10 - 32	8
8	HB-38-16-125	Hex Bolt, $\frac{3}{8}$ - 16 x $1\frac{1}{4}$	2
	HN-38-16	Hex Nut, $\frac{3}{8}$ - 16	2
	HNTL-38-16	Nylon Lock Nut, $\frac{3}{8}$ - 16	2
9*	15-437-01	Keeper	4
	HSM-10-32-100	Hex Bolt, #10 - 32 x 1	4
	HNFL-10-32	Flange Whiz-loc Nut, #10 - 32	4
*	15-437	Rubber Latch and Keeper	4
NS	8980-60	Trim Edge	1

INSTALLATION INSTRUCTIONS

- Release rubber latches (Ref B) holding tailgate screen in place.
- Remove tailgate screen (Ref 6) from tailgate. Unwedge the top and lift out of the bottom tab.
- Install latches (Ref 7) to both sides of the tailgate screen cover and keeper (Ref 9) to tailgate sides using #10-32 Hex Bolts and nuts on the bracket end.
- First, place the hog hair blue filter (Ref 3) onto the tailgate screen, then place tailgate screen cover (Ref 1) over the top of the hog hair filter by placing the screen into the bottom tab and wedging it against the top of the tailgate. Then hook latches to keepers to hold in place.
- Remove Hex Bolts (Ref A) holding the hopper screen cover (Ref 4) to hopper.
- Remove the hopper screen (Ref 5) from the hopper by unwedging the top and pulling it out the bottom tab.
- Place top filter cover (Ref 2) over the hopper screen opening. Secure with $\frac{3}{8}$ - 16 Hex Bolts, nuts and locknuts (Ref 8). Tighten locknut so top filter cover can still hinge on the Hex Bolts.
- Install latches (Ref 7) onto the filter cover (Ref 2) and the keepers (Ref 9) to the sides of the hopper using the 10-32 Hex Bolts and nuts.
- Install the 8980-60 trim edge onto the top of the hopper screen opening.
- Place the hog hair filter (Ref 5) onto the hopper screen. Lower top filter cover and hook latches to the keepers.

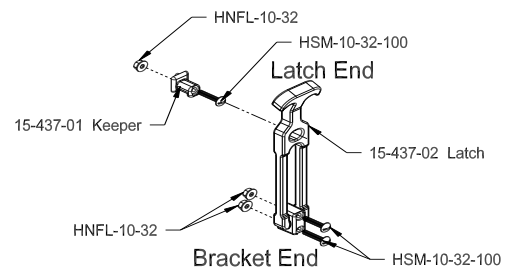

76-754 FRENCH BRUSH REEL KIT

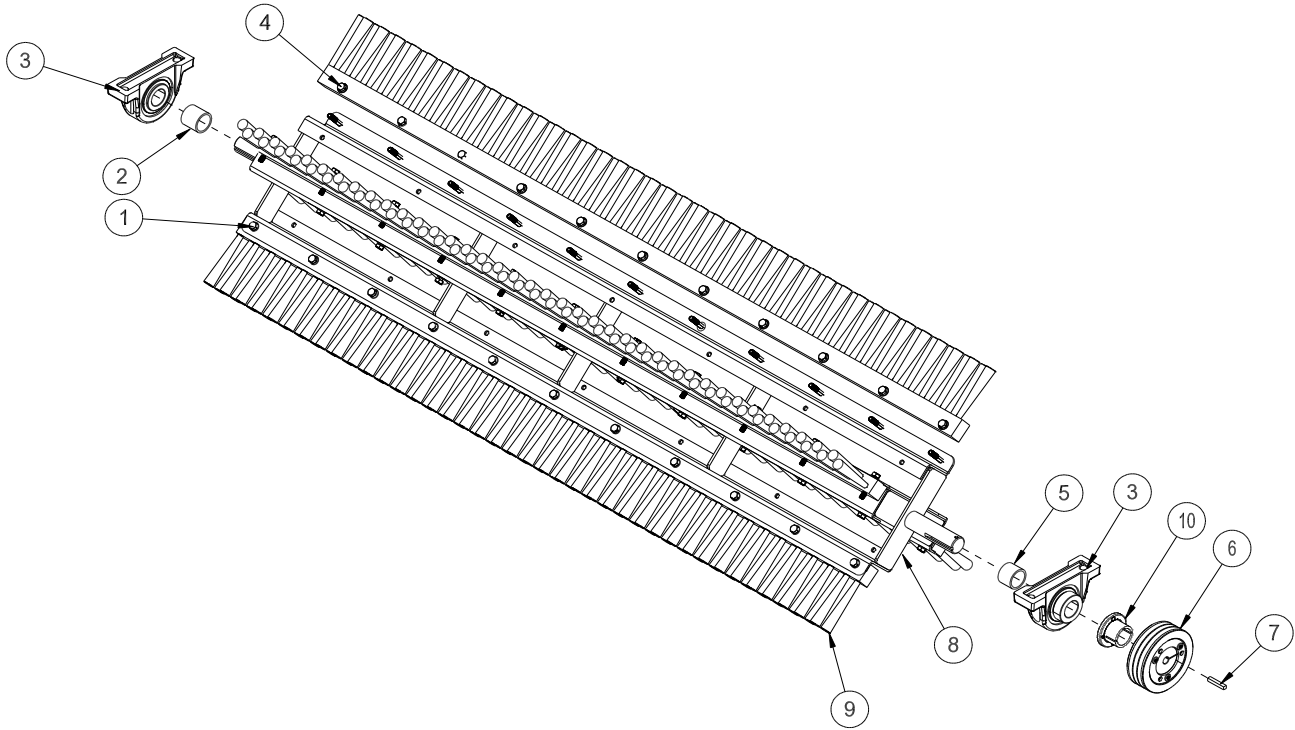

REF	PART#	DESCRIPTION	QUANTITY
1	HB-516-18-175	Hex Bolt, $\frac{5}{16}$ - 18 x $1\frac{3}{4}$	44
	HW-14	Flat Washer, $\frac{1}{4}$	44
2	75-686	Spacer	1
3	75-511	Pillow Block	2
4	HNTL-516-18	Nylon Lock Nut, $\frac{5}{16}$ - 18	44
5	75-834	Spacer	1
6	78-425	Pulley	1
7	HKSQ-14-150	Square Key, $\frac{1}{4}$ x $1\frac{1}{2}$	1
8	76-456	Brush Reel Frame	1
9	76-455	Brush	4
10	78-431	Hub	1

DECAL LIST

This is a list of decals located on the Sweep Star 60. Part number, description and location will help in reordering decals.

A	25-279 Decal, Safety Warning	Belt Guard
B	25-286 Decal, Pinch Point	Front & Back Belt Guard/R&L Hopper Bottom
C	25-298 Decal, Warning Hot	Fan Mount
D	25-307 Decal, Refuel w/ Gasoline	Manifold Mount (above gas tank)
E	25-320 Decal, Warning Load Limit	Left Front Hopper
F	25-355 Decal, Tire Pressure 18 PSI	Front Tires
G	25-355 Decal, Tire Pressure 18 PSI	Rear Tires
H	25-358 Decal, Smithco 12"	Front Dash Console
I	25-359 Decal, Smithco 17"	Rear Hopper
J	25-362 Decal, Fire Danger	Oil Tank Cover
L	25-373 Decal, 7" Smithco Star	Front Oil Tank
M	75-651 Decal, Hopper Lift Safety	Hopper Lift Safety Bar
N	76-304 Decal, Crush/Pinch	R&L Front Hopper
O	76-307 Decal, Tower Warning	R&L Hopper Tower
P	76-417 Decal, Sweep Star 60	R&L Hopper Side
Q	76-536 Decal, Control Panel	Dash Panel

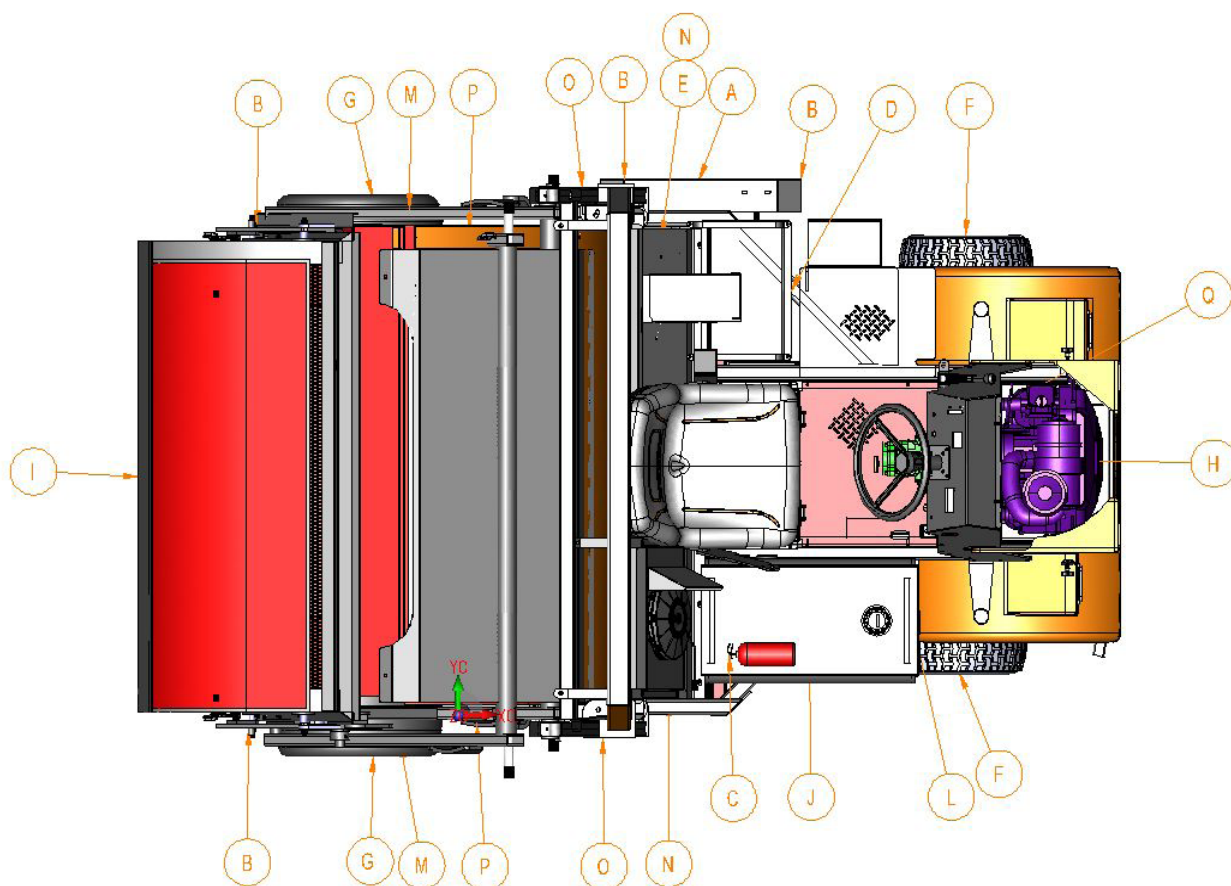

Reference

QUICK REFERENCE REPLACEMENT PARTS

REPLACEMENT FILTERS

60-334	Hydraulic Oil Filter Element	
13-531	Engine Oil filter	Briggs # 842921
76-395-01	Air Cleaner Cartridge	Briggs # 841497
76-395-02	Safety Filter Cartridge	Briggs # 821136
50-403	Fuel Filter	

REPLACEMENT BELTS

76-621	Belt, 3V x 590	3per
--------	----------------	------

SEAL KITS

76-559	Orbitrol	
15-301-01	Seal Kit	
76-638	Hydrostatic Pump	
77-239-23	Seal Kit	
76-539	Reel Motor	
30-101-11	Seal Kit	
76-540	Gear Pump	
76-540-01	Seal Kit	
76-543	RH Wheel Motor	
14-080	Seal Kit	
43-241-01	Replacement Brake	
76-542	LH Wheel Motor	
14-080	Seal Kit	
43-241-01	Replacement Brake	
76-627	Hydraulic Cylinder (Hopper)	
76-242-01	Seal Kit	
15-839	Hydraulic Cylinder (Tailgate & Steering)	
15-839-01	Seal Kit	
76-478	Hydraulic Cylinder (Reel)	
14-531	Seal Kit	

FLUIDS

Engine Oil	SJ or Higher	10W-30
Hydraulic Fluid	SJ or Higher	10W-40

OTHER PARTS

13-488	Key Switch
76-354	2 ¹ / ₂ # ABC Dry Chemical Fire Extinguisher

The Smithco Commercial Products Two-Year Limited Warranty

Smithco, Inc. (Smithco) warrants your 2016 or newer Smithco Commercial Product (“Product”) purchased after October 1, 2016 to be free from defects in materials or workmanship for the period of time listed below. Where a warrantable condition exists, Smithco will repair the Product at no cost to you including diagnosis, labor (at the Smithco standard labor rate, subject to the Smithco flat rate schedule), and parts.

Warranty Duration is:

- (1) Two years, 1500 operational hours* from the date of delivery to the original purchaser or Five years from the date of original manufacturer of the product, whichever occurs first. (*Products equipped with hour meter).
- (2) Products used in rental situations are covered for 90 days from date of delivery to original user/renter.

Owner Responsibilities:

As the Product owner, you are responsible for required maintenance and adjustments stated in your Owner’s Manual. Failure to perform required maintenance and adjustments can be grounds for disallowing a warranty claim. **You are particularly responsible to train all present and future operators of this product on the safe operation of this product at your location.**

Instructions for Obtaining Warranty Service:

You are responsible for notifying the Authorized Smithco Products Distributor from whom you purchased the Product as soon as you believe a warrantable condition exists and not later than 30 days from discovery of the condition.

If you need help locating an Authorized Smithco Distributor, or if you have questions regarding your warranty rights or responsibilities, you may contact us at:

Smithco Product Support Department
200 West Poplar Ave.
Cameron, Wisconsin 54822
Telephone: 800-891-9435 E-Mail: ProductSupport@Smithco.com

Maintenance Parts:

Parts scheduled for replacement as required maintenance (“Maintenance Parts”), are warranted for the period of time up to the scheduled replacement time for that part.

Items/Conditions Not Covered:

Not all product failures or malfunctions that occur during the warranty period are defects in materials or workmanship. The items/conditions listed below are not covered by this warranty:



Product failures which result from the use of non-Smithco replacement parts, or from installation and use of add-on, modified, or unapproved accessories are not covered.



Product failures which result from failure to perform required maintenance and/or adjustments are not covered.



Product failures that result from operating the Product in an abusive, negligent or reckless manner are not covered.



This warranty does not apply to parts subject to consumption through use, unless found to be defective. Examples of parts which are consumed, or used up, during normal Product operation include, but are not limited to: blades, tines, teeth, scarifiers, rakes, plates, wear plates, castor wheels, tires, batteries, filters, belts, nozzles, etc.



This warranty does not apply to failures caused by outside influence. Items considered to be outside influence include, but are not limited to, weather, storage practices, contamination, use of unapproved coolants, lubricants, additives, or chemicals, etc.



This warranty does not apply to normal “wear and tear” items. Normal “Wear and Tear” includes, but is not limited to, damage to seats due to wear or abrasion, worn painted surfaces, scratched decals or windows, etc.



Smithco may require the return of failed parts or components in order to determine the validity of any warranty claim.



Smithco will not be obligated to replace components of other manufacturers if inspection by the original component manufacturer indicates that failure was due to normal wear and tear, expected consumption through use or improper care or service.

Other Legal Disclaimers:

The above remedy for product defects through repair or replacement by an authorized Smithco distributor or dealer is the purchaser’s sole remedy for any defect. This warranty gives you specific legal rights, and you may also have other rights which vary from state to state.

THERE ARE NO OTHER EXPRESS WARRANTIES OTHER THAN THOSE SET FORTH ABOVE. ALL IMPLIED WARRANTIES OF MERCHANTABILITY AND FITNESS FOR USE ARE LIMITED TO THE DURATION OF THE LIMITED WARRANTIES CONTAINED HEREIN.

Some states may not allow limitations on how long an implied warranty lasts, so the above limitation may not apply to you.

THE SMITHCO COMPANY IS NOT LIABLE FOR INDIRECT, INCIDENTAL OR CONSEQUENTIAL DAMAGES IN CONNECTION WITH THE USE OF THE PRODUCT, INCLUDING ANY COST OR EXPENSE OF PROVIDING A SUBSTITUTE PRODUCT OR SERVICE DURING PERIODS OF MALFUNCTION OR NON-USE.

Some states may not allow the exclusion of indirect, incidental or consequential damages, so the above exclusion may not apply to you.

Smithco neither assumes, nor authorizes any person to assume for it, any other liability in connection with the sale or use of this product.

