

Parts & Service



**SweepStar 60**  
**Gas and Diesel**  
**76-000-D and 77-100-C**  
SN: 2614

**February 2021**

**Product Support:**

**Hwy 55 & Poplar Ave; Cameron WI 54822**  
**1-800-891-9435 [productsupport@smithco.com](mailto:productsupport@smithco.com)**

# CONTENTS

Introduction

<b>Introduction</b> .....	<b>1-3</b>
Safe Practices .....	2
Specifications .....	3
Optional Equipment .....	3

Service

<b>Service</b> .....	<b>4-11</b>
Maintenance .....	4-6
Service Chart .....	7-8
End User's Service Chart .....	9-10
Adjustments .....	11
Storage .....	11

Diagrams

<b>Diagrams</b> .....	<b>12-17</b>
Diesel Wiring Diagram .....	12-13
Gas Wiring Diagram .....	14-15
Hydraulic Diagram .....	16-17

Parts

<b>Parts</b> .....	<b>18-107</b>
Body and Frame .....	18-19
Roll Over Protection (ROPS) .....	20-21
Steering .....	22-23
Front Fork .....	24-25
Gasoline Linkage .....	26-27
Diesel Linkage .....	28-29
Gas Console .....	30-31
Diesel Console .....	32-33
Gas Tank and Oil Tank .....	34-35
Fuel Tank and Oil Tank .....	36-37
Oil Filter .....	38-39
Hydraulic Lift Cylinder .....	38-39
Reel Lift Cylinder .....	40-41
Tailgate Cylinder .....	40-41
Vanguard Gas Engine and Exhaust .....	42-43
Kubota Diesel Engine and Exhaust .....	44-47
Electric Clutch Driven Belt Drive .....	48-49
Finger/Brush Reel .....	50-51
Rear Axle .....	52-55
Hopper .....	56-59
Tailgate .....	60-61
77-266 Eaton Hydrostatic Pump (Diesel) .....	62-63
76-638 Eaton Hydrostatic Pump (Gas) .....	64-65
Hydrostatic Pump Repair Instructions .....	66-76
76-197 Gear Pump .....	77
Gear Pump Repair Instructions .....	78-83
76-238 Rear Wheel Motor .....	84
Wheel Motor Repair Instructions .....	85-106
76-023 3-Bank Hydraulic Valve .....	107

Accessories

<b>Accessories</b> .....	<b>108-110</b>
76-271 Dust/Dirt Filtration Pack .....	108-109
76-488 French Brush Reel .....	110

Reference

<b>Reference</b> .....	<b>111-112</b>
Decal List .....	111
Quick Reference Replacement Parts .....	112
Warranty .....	

Thank you for purchasing a **Smithco** product.

Read this manual and all other manuals pertaining to the Sweep Star 60 carefully as they contain safety, operating, assembly and maintenance instructions. Failure to do so could result in personal injury or equipment damage.

Keep manuals in a safe place after operator and maintenance personnel have read them. Right and left sides are from the operator's seat, facing forward.

 **WARNING:**

**Engine exhaust and some of its constituents are known to the State of California to cause cancer, birth defects, and other reproductive harm.**  
For more information visit [www.P65Warning.ca.gov](http://www.P65Warning.ca.gov)

**WARNING**

*Failure to follow cautious operating practices can result in serious injury to the operator or other persons. The owner must understand these instructions, and must allow only trained persons who understand these instructions to operate this vehicle.*

All **Smithco** machines have a Serial Number and Model Number. Both numbers are needed when ordering parts. The serial number plate on the Sweep Star 60 is located on the left front main frame, in front of the engine. Refer to engine manual for placement of engine serial number.

For product and accessory information, help finding a dealer, or to register your product please contact us at [www.Smithco.com](http://www.Smithco.com).

Information needed when ordering replacement parts:

1. Model Number of machine
2. Serial Number of machine
3. Name and Part Number of part
4. Quantity of parts

For easy access record your Serial and Model numbers here.

<b>SMITHCO</b> WAYNE, PENNSYLVANIA 19087 USA 610-688-4009 Fax 610-688-6069			
SERIAL NO. <input type="text"/>	kW/hp <input type="text"/>	DATE OF MFG. <input type="text"/>	
MODEL NO. <input type="text"/>	lb/kg Empty <input type="text"/>	lb/kg Full <input type="text"/>	

## SAFE PRACTICES

- .It is your responsibility to read this manual and all publications associated with this machine (engine, accessories and attachments).
2. Never allow anyone to operate or service the machine or its attachments without proper training and instructions. Never allow minors to operate any equipment.
  3. Learn the proper use of the machine, the location and purpose of all the controls and gauges before you operate the equipment. Working with unfamiliar equipment can lead to accidents.
  4. Wear all the necessary protective clothing and personal safety devices to protect your head, eyes, ears, hands and feet. Operate the machine only in daylight or in good artificial light.
  5. Inspect the area where the equipment will be used. Beware of overhead obstructions and underground obstacles. Stay alert for hidden hazards.
  6. Never operate equipment that is not in perfect working order or without decals, guards, shields, or other protective devices in place.
  7. Never disconnect or bypass any switch.
  8. Carbon monoxide in the exhaust fumes can be fatal when inhaled, never operate a machine without proper ventilation.
  9. Fuel is highly flammable, handle with care.
  10. Keep engine clean. Allow the engine to cool before storing and always remove the ignition key.
  11. After engine has started, machine must not move. If movement is evident, the neutral mechanism is not adjusted correctly. Shut engine off and readjust so the machine does not move when in neutral position.
  13. Never use your hands to search for oil leaks. Hydraulic fluid under pressure can penetrate the skin and cause serious injury.
  14. This machine demands your attention. To prevent loss of control or tipping of the vehicle:
    - A. Use extra caution in backing up the vehicle. Ensure area is clear.
    - B. Do not operate on a slope greater than 10°. Pay careful attention to the inclinometer on you machine.
    - C. Do not stop or start suddenly on sloped surfaces.
    - D. Reduce speed on slopes and in all turns. Use caution when changing directions on all surfaces.
    - E. Do not change directions of travel on any slope.
    - F. Do not operate debris hopper lift or tailgate while on slopes.
    - G. Stay alert for holes in the terrain and other hidden hazards.
  15. Before leaving operator's position for any reason:
    - A. Disengage all drives.
    - B. Lower all attachments to the ground.
    - C. Set park brake.
    - D. Shut engine off and remove the ignition key.
  16. Keep hands, feet and clothing away from moving parts. Wait for all movement to stop before you clean, adjust or service the machine.
  17. Keep the area of operation clear of all bystanders.
  18. Never carry passengers.
  19. Stop engine before making repairs/adjustments or checking/adding oil to the crankcase.
  20. Use parts and materials supplied by SMITHCO only. Do not modify any function or part.
  21. Do not remove the radiator cap when the engine is hot. When cooled, loosen cap slightly to the stop to relieve any pressure before removing the cap completely.

***These machines are intended for operation by well trained persons performing professional maintenance on golf courses, sports turf, and any other area maintained turf and related trails, paths and lots. No guaranty as to the suitability for any task is expressed or implied.***



# SPECIFICATIONS FOR SWEEP STAR 60 GAS & DIESEL

## WEIGHTS AND DIMENSIONS

Length	129" (328 cm)
Width	74.5" (179 cm)
Height with Hopper Down	82" (208 cm)
Height with Hopper Up	127" (323 cm)
Wheel Base	68.5" (174 cm)
Weight	2200 lbs (998 kg)

## ROLL OVER PROTECTION BAR

Standard on all Machines

## SOUND LEVEL

At ear level
At 3 ft (0.914 m)
At 30 ft (9.14 m)

## GAS ENGINE

92 dB
86 dB
64 dB

## DIESEL ENGINE

98 dB
96 dB
74 dB

## ENGINE

Make
Model#
Type / Spec#
Horsepower
Fuel
Cooling System
Lubrication System
Alternator

## GAS

Briggs & Stratton
603477
0171-J1
35 Hp (26 kw)
Unleaded 87 Octane
Gasoline Minimum
Air Cooled
Full Pressure
24 Amp

## DIESEL

Kubota
D 722 B1
19Hp (14 kw)
No. 2 Diesel
Liquid Cooled
Full Pressure
40 Amp

## Tire & Wheels

Front: One 18 x 9.50 x 8 Multi-rib (20 psi; 1.4 bar)
Front tire and wheel fluid filled to 50 lbs. total. 28 pints of windshield washer fluid or equivalent.
Rear: Two 24 x 13.00 x 12 Super Soft (18 psi; 1.3 bar)
Castor: 9 x 3.5 - 4 (20 psi; 1.4 bar)

## SPEED

Forward Speed	0 to 12 m.p.h. (0-19 kph)
Reverse Speed	0 to 4 m.p.h. (0-6 kph)

## BATTERY

BCI Group	Automotive type 45 -12 volt
Cold Cranking Amps	Size 45
Ground Terminal Polarity	480 minimum
Maximum Length	Negative (-)
Maximum Width	9" (23 cm)
Maximum Height	5.38" (14 cm)
	9" (23 cm)

## FLUID CAPACITY

Crankcase Oil	See Engine Manual	See Engine Manual
Fuel	6 gallon (22,7 liters)	5 gallon (19 liters)
Hydraulic Fluid	5 gallon (19 liters)	5 gallon (19 liters)
Cooling		Kubota approximately 1 gallon (3.8 liters)
Grade of Hydraulic Fluid	SAE 10W-40 API Service SJ or higher Motor Oil	

## OPTIONAL EQUIPMENT

77-328	60" Brush Kit
76-329	60" Finger Reel Kit
76-271	Filtration Pack
77-218	Triple Castor Wheel Kit

# MAINTENANCE

## LUBRICATION

Use No. 2 General Purpose Lithium Base Grease and lubricate every 100 hours. The Sweep Star 60 has eleven grease fittings.

- A. One on the outside of each tower.
- B. One on hydrostatic forward and reverse relay.
- C. One on the center of park brake relay on rear axle.
- D. One on hydrostatic pedal under the floorboard.
- E. One on each castor wheel mount bracket.
- F. One on rear skid pivot.
- G. One on each pillow block bearing on end of finger reel.
- H. One on rod end of the tailgate cylinder.

Every 500 hours of operation, separate the hydrostatic pump from the engine. Clean the splined areas and lightly grease the male portion of the pump spline. Use either Dow Corning® G-N Metal Assembly Paste or #77 Assembly Paste (Kohler # 25 357 12-s).

As you remount the pump to the engine, be certain the mating surface are clean and free of any foreign material and that the pump is correctly aligned.

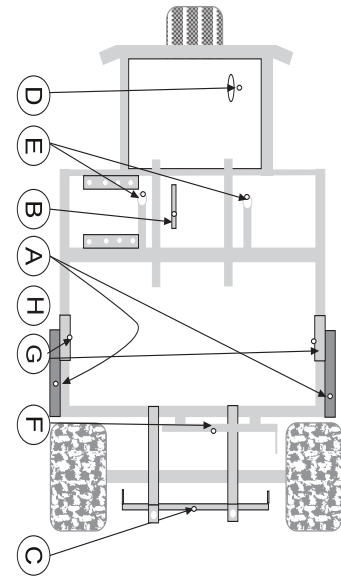

## HYDRAULIC OIL

1. Use SAE 10W-40 API Service SJ or higher motor oil.
2. For proper warranty, change oil every 500 hours or annually, whichever is first and change the filter after the first 50 hours, then every 250 hours thereafter.
3. The oil level should be 2" to 2 1/2" from top of the tank when fluid is cold. Do not overfill.
4. After changing oil and/or filter, run the machine for a few minutes. Check oil level and for leaks.
5. Always use caution when filling hydraulic oil tank or checking level to keep system free of contaminants. Check and service more frequently when operating in extremely cold, hot or dusty conditions.
6. If natural color of fluid is now black or smells burnt, it is possible that an overheating problem exists.
7. If fluid becomes milky, water contamination may be a problem.
8. If either of the above conditions happen, change oil and filter immediately after fluid is cool and find cause. Take fluid level readings when system is cold.
9. In extreme temperatures you can use straight weight oil. We recommend SAE 30W API Service SJ or higher when hot (above 90°F (33°C)) and SAE 10W API Service SJ or higher when cold (below 32°F (0°C)) ambient temperature. Use either motor oil or hydraulic oil, but do not mix.
10. Oil being added to the system must be the same as what is already in the tank. Mark tank fill area as to which type you put in.

## SWEEPING

While sweeping close tailgate frequently to ensure tailgate does not creep open. While operating the sweeper head it is important to disengage the head before raising. If the sweeper head is raised while engaged, it can cause the belt to slip off the pulleys. This can result in belt failure and engine crankshaft failure.

### DISENGAGE THE SWEEPER HEAD BEFORE RAISING.

## FILTER PACK

Filter pack may be cleaned by shaking or spraying off with low pressure water. Filter will disintegrate if high pressure is used on it.

## ENGINE OIL

Change and add oil according to charts below. Do not overfill. Use a high quality detergent oil. **For Briggs engine** use oil classified “For Service SJ or higher” SAE 30 oil. **For Kubota Diesel engine** use oil classified “For Service CC, CD or CE” API oil. Use no special additives with recommended oils. Do not mix oil with gasoline. If the CF-4 or CG-4 lubrication oil is used with high-sulfur fuel, change the lubricating oil more often.

SAE 30 oil, if used below 40° F (4° C), will result in hard starting and possible engine bore damage due to inadequate lubrication.

The use of non-synthetic multi-viscosity oils in temperatures above 80°F (27° C) will result in higher than normal oil consumption. Check oil level more frequently when using a multi-viscosity oil.

### SAE Viscosity Grades

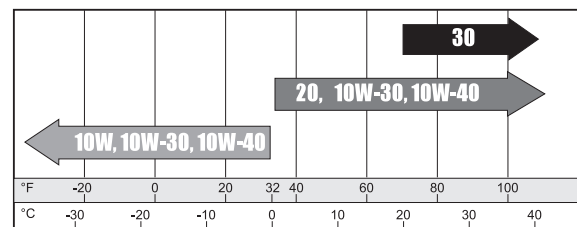
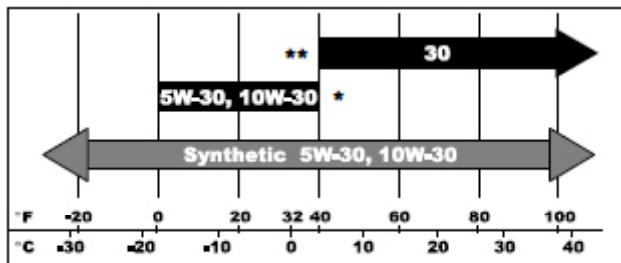

Starting Temperature Range Anticipated Before Next Oil Change

## TOWING

When it is necessary to move the Sweep Star 60 without engine running, the bypass valve built into hydrostatic pump must be “open” by turning it counterclockwise. The valve is located on bottom left of pump. An “open” valve allows fluid to pass through the wheels freely. When normal, driven, operation is desired, valve should be closed by turning it clockwise. Failure to “close” the valve with engine running means no power to wheels.

## BATTERY

Batteries normally produce explosive gases which can cause personal injury. Do not allow flames, sparks or any ignited object to come near the battery. When charging or working near battery, always shield your eyes and always provide proper ventilation.

Battery cable should be disconnected before using “Fast Charge”.

Charge battery at 15 amps for 10 minutes or 7 amps for 30 minutes. Do not exceed the recommended charging rate. If electrolyte starts boiling over, decrease charging.

Always remove grounded (-) battery clamp first and replace it last. Avoid hazards by:

1. Filling batteries in well-ventilated areas.
2. Wear eye protection and rubber gloves.
3. Avoid breathing fumes when electrolyte is added.
4. Avoid spilling or dripping electrolyte.

### WARNING

**Battery Electrolyte is an acidic solution and should be handled with care. If electrolyte is splashed on any part of your body, flush all contact areas immediately with liberal amounts of water. Get medical attention immediately.**

# MAINTENANCE (CONTINUED)

## WHEEL MOUNTING PROCEDURE

### REAR WHEELS

1. Set park brake. Turn machine off and remove key.
2. Block one of the other wheels.
3. Loosen nuts slightly on wheel to be removed.
4. Jack up machine being careful not to damage underside of machine.
5. Remove nuts, remove wheel.
5. Place new wheel on hub lining up bolt holes.
6. Torque nuts to 64-74 ft/lb (87-100 Nm) using a cross pattern. Torque again after first 8 hours and every 200 hours thereafter.
7. Lower machine to ground and remove blocks and jack.

### FRONT WHEEL

1. Set park brake. Turn machine off and remove key.
2. Block one of the other wheels.
3. Remove cotter pins from each end of the axle.
4. Remove axle nuts, machine bushings and axle locks.
5. Jack up front of machine being careful not to damage underside of machine.
6. Wheel and axle will come out of slots in the u-bracket, pull wheel forward.
7. Place new wheel on hub lining up bolt holes.
8. Torque nuts to 64-74 ft/lb (87-100 Nm) using a cross pattern. Torque again after first 10 hours and every 200 hours thereafter.
9. Lower machine to ground and remove blocks and jack.

## TIRE PRESSURE

Caution must be used when inflating a low tire to recommended pressure. Over inflating can cause tires to explode. Front tires and castor wheel should be 20 psi (1.4 bar), rear tires should be 18 psi (1.3 bar) maximum. Improper inflation will reduce tire life considerably.

## JUMP STARTING

### ⚠ WARNING

**Use of booster battery and jumper cables. Particular care should be used when connecting a booster battery. Use proper polarity in order to prevent sparks.**

To jump start (negative grounded battery):

1. Shield eyes.
2. Connect ends of one cable to positive (+) terminals of each battery, first (A) then (B).
3. Connect one end of other cable to negative (-) terminal of "good" battery (C).
4. Connect other end of cable (D) to engine block on unit being started (NOT to negative (-) terminal of battery)

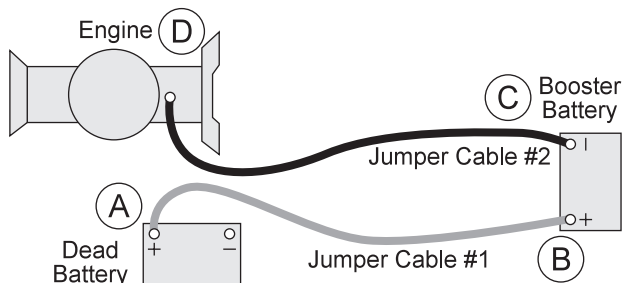

To prevent damage to other electrical components on unit being started, make certain that engine is at idle speed before disconnecting jumper cables.

## SERVICE CHART GAS

### ⚠ CAUTION

Before servicing or making adjustments to the machine, stop engine, set park break, block wheels and remove key from ignition.

### ⚠ IMPORTANT

Follow all procedures and **ONLY** use parts prescribed by the manufacturer. Read the engine manual before maintenance.

The suggested maintenance checklist is not offered as a replacement for the manufacturer's engine manual but as a supplement. You must adhere to the guidelines established by the manufacturer for warranty coverage. In adverse conditions such as dirt, mud or extreme temperatures, maintenance should be more frequent.

Maintenance Service Interval	Maintenance Procedure
After the first 8 operating hours	Torque the wheel lug nuts. (64-74 ft/lb (87-100 Nm))
	Change the engine oil filter.
Before each use daily	Check the engine oil level.
	Clean area around muffler and controls.
	Check the hydraulic fluid level.
	Check the tire pressure.
	Check and clean Debris Filter Pack1
	Check condition of hydraulic hoses and fittings.
	Inspect and clean the machine.
After the first 50 hours	Change Hydraulic Oil Filter.
Every 100 hours	Clean or change air filter.1&2
	Clean pre-cleaner.1
	Change engine oil and filter.
	Replace spark plug .
	Lubricate machine.
	Clean or change remote air cleaner.
	Check the battery fluid level and cable connections..
	Service exhaust system.
	Check belt tension .
Every 250 hours	Check engine valve clearance and adjust if necessary.
	Check idle speed.
	Clean battery terminals.
	Change hydraulic oil filter.
	Torque the wheel lug nuts. (64-74 ft/lb (87-100 Nm))
Every 500 hours or yearly	Change fuel filter.
	Change hydraulic oil and filter.
	Clean oil cooler fins.1
	Replace air filter2
	Replace fuel filter
	Clean air cooling system.1
	Check safety filter in remote air cleaner.
1 In dusty conditions or when airborne debris is present, clean more often.	
2 Every third air filter change, replace the inner safety filter.	

# SERVICE CHART DIESEL

## ⚠ CAUTION

Before servicing or making adjustments to the machine, stop engine, set park break, block wheels and remove key from ignition.

## ⚠ IMPORTANT

Follow all procedures and **ONLY** use parts prescribed by the manufacturer. Read the engine manual before maintenance.

The suggested maintenance checklist is not offered as a replacement for the manufacturer's engine manual but as a supplement. You must adhere to the guidelines established by the manufacturer for warranty coverage. In adverse conditions such as dirt, mud or extreme temperatures, maintenance should be more frequent.

Maintenance Service Interval	Maintenance Procedure
After the first 8 operating hours	Torque the wheel lug nuts. (64-74 ft/lb (87-100 Nm))
	Change the engine oil filter.
Before each use daily	Check the engine oil level.
	Clean area around muffler and controls.
	Check the hydraulic fluid level.
	Check the tire pressure.
	Check and clean Debris Filter Pack1
	Check condition of hydraulic hoses and fittings.
	Check for oil or water leaks.
	Proper function of glow lamp timer.
	Color of exhaust fumes.
Inspect and clean the machine.	
After the first 50 hours	Change Hydraulic Oil Filter.
	Change Engine oil and filter.
Every 100 hours	Clean or change air filter.1
	Clean pre-cleaner.1
	Change engine oil and filter.
	Replace spark plug .
	Lubricate machine.
	Clean or change remote air cleaner.
	Check the battery fluid level and cable connections..
Check belt tension .	
Every 200 hours	Check radiator hoses and clamp bands.
	Check idle speed.
	Replace oil filter cartridge.
	Change hydraulic oil filter.
	Check air intake line
	Torque the wheel lug nuts. (64-74 ft/lb (87-100 Nm))
Every 500 hours or yearly	Change fuel filter.
	Change hydraulic oil and filter.
	Clean oil cooler fins.1
	Clean air cooling system.1
	Change radiator coolant.







## ADJUSTMENTS

### PARK BRAKE ADJUSTMENT

By turning knob on end of park brake lever you can tighten or loosen brake a small amount. To tighten turn the knob clockwise. To loosen turn counter clockwise. If this is not enough turn clevis on brake cable to adjust length of cable.

### STEERING CHAIN ADJUSTMENT

Steering Sprockets (A) should be level with each other. Check with straight edge. Make any adjustments. Slide Idler Pulley (B) so that it is snug onto the chain. Tighten all nuts and bolts in place.

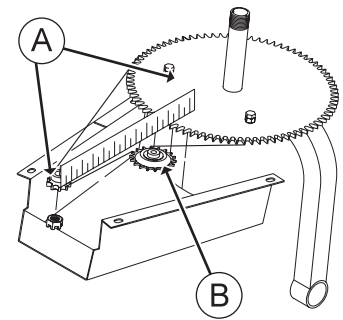

### WHEEL 'CREEP' ADJUSTMENT

'Creep' is when engine is running and hydrostatic transmission is in neutral, but due to inadequate alignment, wheels still move. Do the following procedures to stop this motion.

1. Lift up and support the unit so rear wheels are off the ground and can turn freely.
2. On the side of hydrostatic transmission is the Shift Arm (C). In the 'V' shaped notch of shift arm rests Idler Pulley (D). This Pulley is mounted on an Idler Arm (E).
3. Loosen bolt and nut holding Pulley to Idler Arm. Leave finger tight.
4. With engine running, slide the Pulley in Idler Arm slot until it centers on Shift Arm on hydrostatic and wheel 'creep' stops.
5. Tighten all fasteners and test by using foot pedal linkage to see that the 'creep' is removed.
6. Turn the engine off and lower the machine.

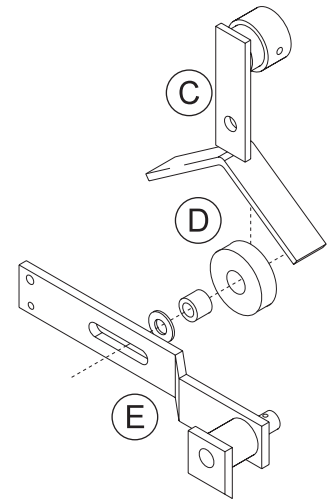

**WARNING**

**Do not lift reel head while engage. Disengage reel before lifting or lowering.**

## STORAGE

When storing, remove the key from the key switch to avoid unauthorized persons from operating machine.

1. Before storing clean machine thoroughly.
2. Check bolts and nuts, tighten as necessary.
3. Make all repairs that are needed and remove any debris.
4. Remove the battery, adjust the electrolyte level and recharge it. Store the battery in a dry, dark place.
5. Store in a clean and dry area, but NOT near a stove, furnace or water heater which uses a pilot light or any device that can create a spark.
6. Engines stored over 30 days need to be protected or drained of fuel to prevent gum from forming in a fuel system or on essential carburetor parts. Check the engine manual and follow the instructions for the storage of the engine.

# DIESEL WIRING DIAGRAM

## Color Code Chart

Bl	Blue
Br	Brown
Y	Yellow
Grn	Green
O	Orange
R	Red
B	Black
P	Purple
W	White

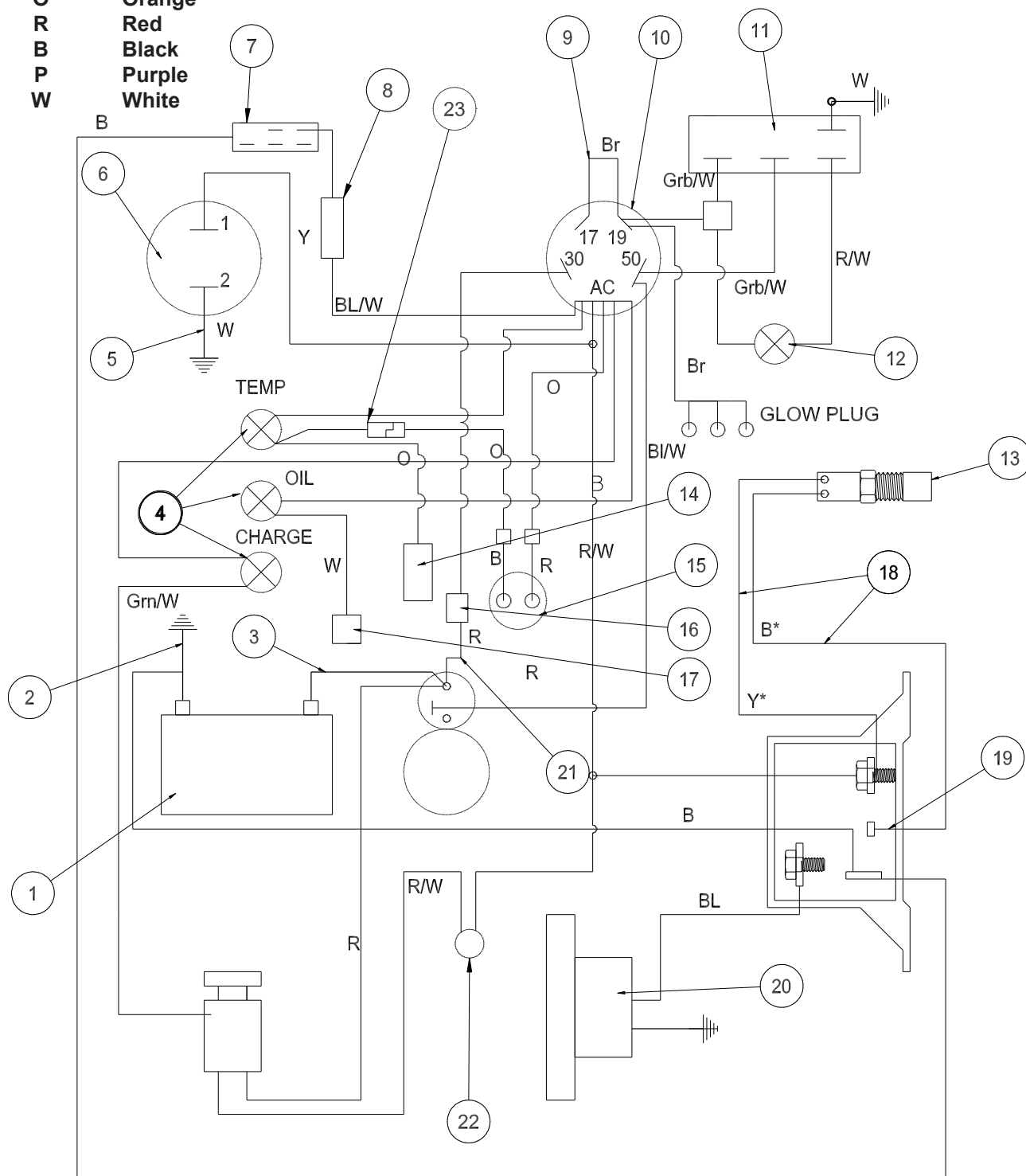

Diagrams

## DIESEL WIRING PARTS LIST

REF#	PART#	DESCRIPTION	QUANTITY
1	22-073	Battery	1
	48-166	Battery Holddown	1
2	48-147	Black Battery Cable	1
3	48-157	Red Battery Cable	1
	8892-46.5	Hose Wrap 1/4 x 46.5	1
4	50-359	Warning Indicator Lights	3
5	77-209	Hour Meter to Ground Wire	1
6	12-804	Hour Meter	1
7	76-337	Electric Clutch	1
	17-271	Pigtail	1
8	15-314	Toggle Switch	1
	15-472	Boot	1
9	77-226	Wire 17 to 19 Ignition Switch	1
10	17-068	Key Switch	1
	17-079	Key Set	1
11	77-223	Glow Lamp Timer	1
12	50-359	Glow Plug Indicator Light	1
	8875	Bullet Terminal	1
	8874	Line Connector	1
	8963	Heat Shrink	2
13*	77-208-05	Air Pack Switch (part of engine)	1
14	77-208-01	Temperature Sender (part of engine)	1
15	77-207	Buzzer	1
16	77-261	40 Amp Circuit Breaker	1
	8977	Circuit Breaker Boot	1
17		Oil Sender (part of engine)	1
18*	77-234	Thermostat Wire Harness	1
19*	77-233	Bosch Power Relay	1
20	77-201	Electric Fan	1
	8844-9	Light Blue Wire	1
	8849-14	Black Wire	1
	8900-14	Flex Loom	1
	8854	Fork terminal	1
	8860	Butt Connector	2
	8933	Ring terminal	1
21	48-144	Circuit Breaker Wire	1
22	14-292	Seat Switch	1
23	9016	Weather Pack	1
	9017	Weather Pack Terminal	2
	9018	Seal	2
	77-262	Wire Harness (contains all wires except # 5 & 15)	1
*	77-235	Thermostat Kit	
	22-065	Axillary Ground	1

# GAS WIRING DIAGRAM

## Color Code Chart

Bl	Blue
Br	Brown
Y	Yellow
Grn	Green
O	Orange
R	Red
B	Black
P	Purple
W	White

Diagrams

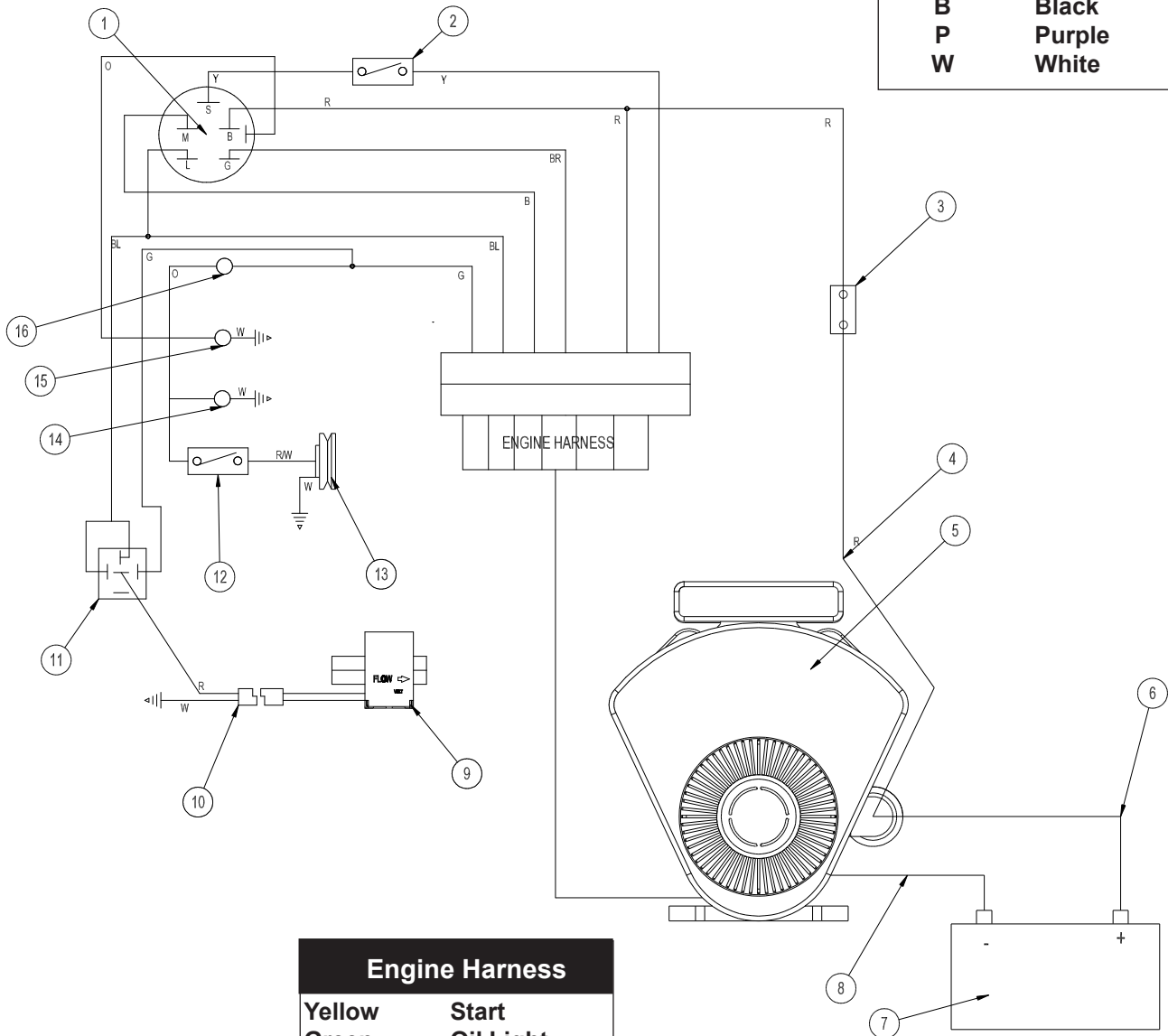

## Engine Harness

Yellow	Start
Green	Oil Light
Brown	Ground
Red	Rectifier
Black	Magneto
Gray	Fuel Solenoid

## GAS WIRING PARTS LIST

REF#	PART#	DESCRIPTION	QUANTITY
1	13-488	Key Switch with Hardware	1
2	14-292	Seat Switch	1
3	77-261	Circuit Breaker 40 AMP	1
	8977	Circuit Breaker Boot	1
4	48-144	Circuit Breaker Wire	1
5	76-636	Briggs & Stratton 35hp Gas Engine	1
6	48-157	Red Battery Cable	1
	8892-46.5	Hose Wrap 1/4 x 46.5	1
7	22-073	Battery	1
8	48-147	Black Battery Cable	1
9	76-757	Fuel Pump with connectors	1
	9027	Terminal Tap	1
10	76-472	Fuel Pump Wire Harness	1
11	30-042-06	Relay	1
12	15-314	Toggle Switch	1
	15-472	Switch Boot	1
13	76-412	Electric Clutch	1
14	76-397	Voltmeter	1
15	12-804	Hour Meter	1
16	50-359	Warning Indicator Light	1
	76-394	Wire Harness	1

Diagrams

# HYDRAULIC DIAGRAM

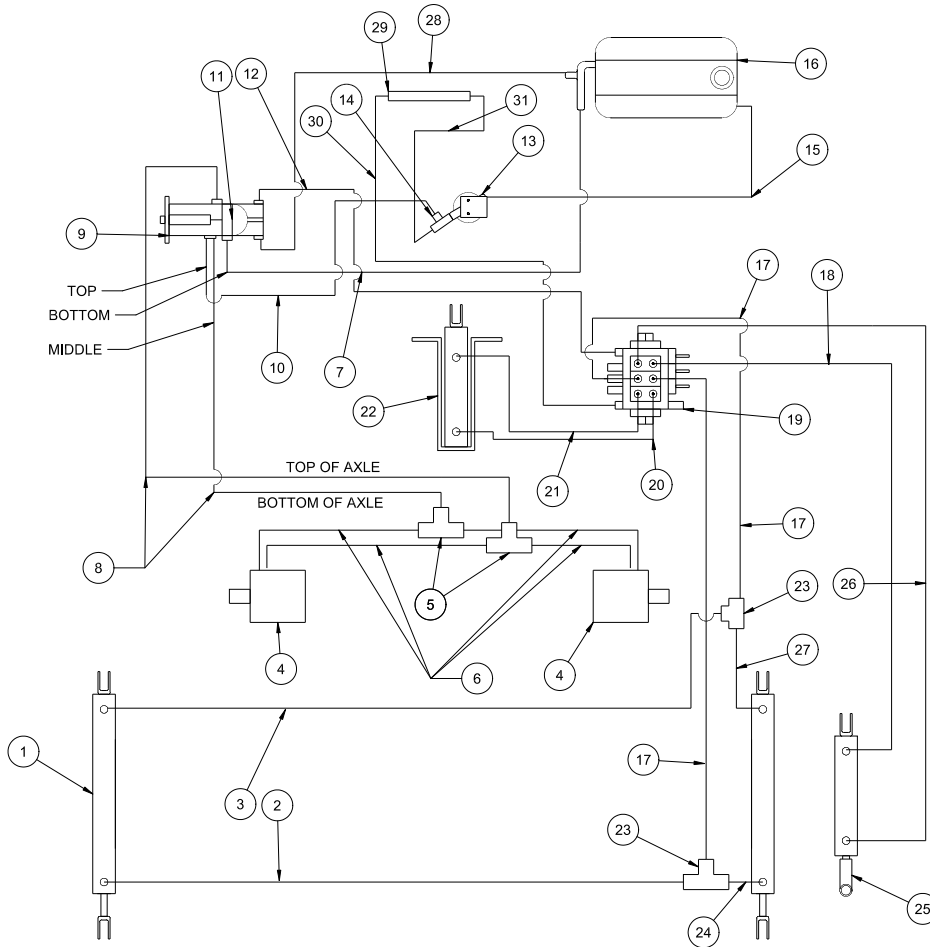

## 76-023 Hydraulic Valve

Relief Valve set at 2000 psi (137.93 bar)

## Hydrostatic Pump

Displacement Variable to 1.44 in<sup>3</sup>/R (23.6 cm<sup>3</sup>/R)  
 22.44 gpm (84.94 lpm) at 3600 rpm

Max Operating Speed 3600 rpm

Rated Pressure 3000 psi (206.8 bar)

Max Pressure 5000 psi (344.7 bar)

Max Inlet Vacuum 6 in Hg (.203 bar)

Max Inlet Temperature 225°F (107°C)

Max Allowable Case Pressure 25 psi (1.72 bar)

## 76-197 Gear Pump

Displacement .40 in<sup>3</sup>/R (6.6 cm<sup>3</sup>/R) 6.23 gpm (25.39 lpm)

# HYDRAULIC DIAGRAM PARTS LIST

REF#	PART#	DESCRIPTION	QUANTITY
1	76-627	Hydraulic Cylinder	2
2	76-115	Hydraulic Hose	1
3	76-114	Hydraulic Hose	1
4	76-238	Wheel Motor	2
5	34-057	Tee	2
6	76-208	Hydraulic Hose	4
7	8832-18.5	Suction Hose (gas)	1
	8832-24	Suction Hose (diesel)	1
	18-040	Hose Clamp	2
8	76-209	Hydraulic Hose	2
	8895-48	1" Hose Wrap	2
9	76-638	Hydrostatic Pump (Gas)	1
	77-266	Hydrostatic Pump (Diesel)	1
10	76-207	Hydraulic Hose	1
	8892-21	1/4" Hose Wrap	1
11	76-197	Gear Pump	1
12	76-104	Hydraulic Hose	1
	8892-29	1/4" Hose Wrap	1
13	23-006	Oil Filter	1
	23-031	Filter Element (Replacement Only)	1
14	18-190	Tee	1
15	8917-38	Suction Hose 5/8 ID	1
	18-040	Hose Clamp	2
16	60-473	Oil Tank	1
17	76-202	Hydraulic Hose	2
18	76-204	Hydraulic Hose	1
	8892-26	1/4" Hose Wrap	1
19	76-023	Hydraulic Valve	1
20	76-205	Hydraulic Hose	1
	8892-31	1/4" Hose Wrap	1
21	76-206	Hydraulic Hose	1
	8892-27	1/4" Hose Wrap	1
22	76-478	Hydraulic Cylinder	1
23	18-173	Tee 3/8 Junction Union	2
24	76-117	Hydraulic Hose	1
25	77-263	Hydraulic Cylinder	1
26	76-203	Hydraulic Hose	1
	8892-26	1/4" Hose Wrap	1
27	76-116	Hydraulic Hose	1
28	8832-17.5	Suction Hose (gas)	1
	8832-17	Suction Hose (diesel)	1
	18-040	Hose Clamp	2
29	23-172	Cooler	1
	76-458	Cooler Mount Kit	1
30	76-459	Hydraulic Hose, 75"	1
	8892-44	Hose Wrap	1
31	76-460	Hydraulic Hose, 63"	1
	8892-44	Hose Wrap	1
32	18-190	Tee	1
	8892	1/4" Hose Wrap	

# BODY AND FRAME DRAWING

When Filtration System is to be installed, Ref. 9 Hopper Screen Cover is to be removed.

When Filters are used, 76-262 Tailgate Screen is replaced by 76-249 Tailgate Filter Screen. 76-261 Hopper Screen is replaced by 76-248 Hopper Filter Screen.

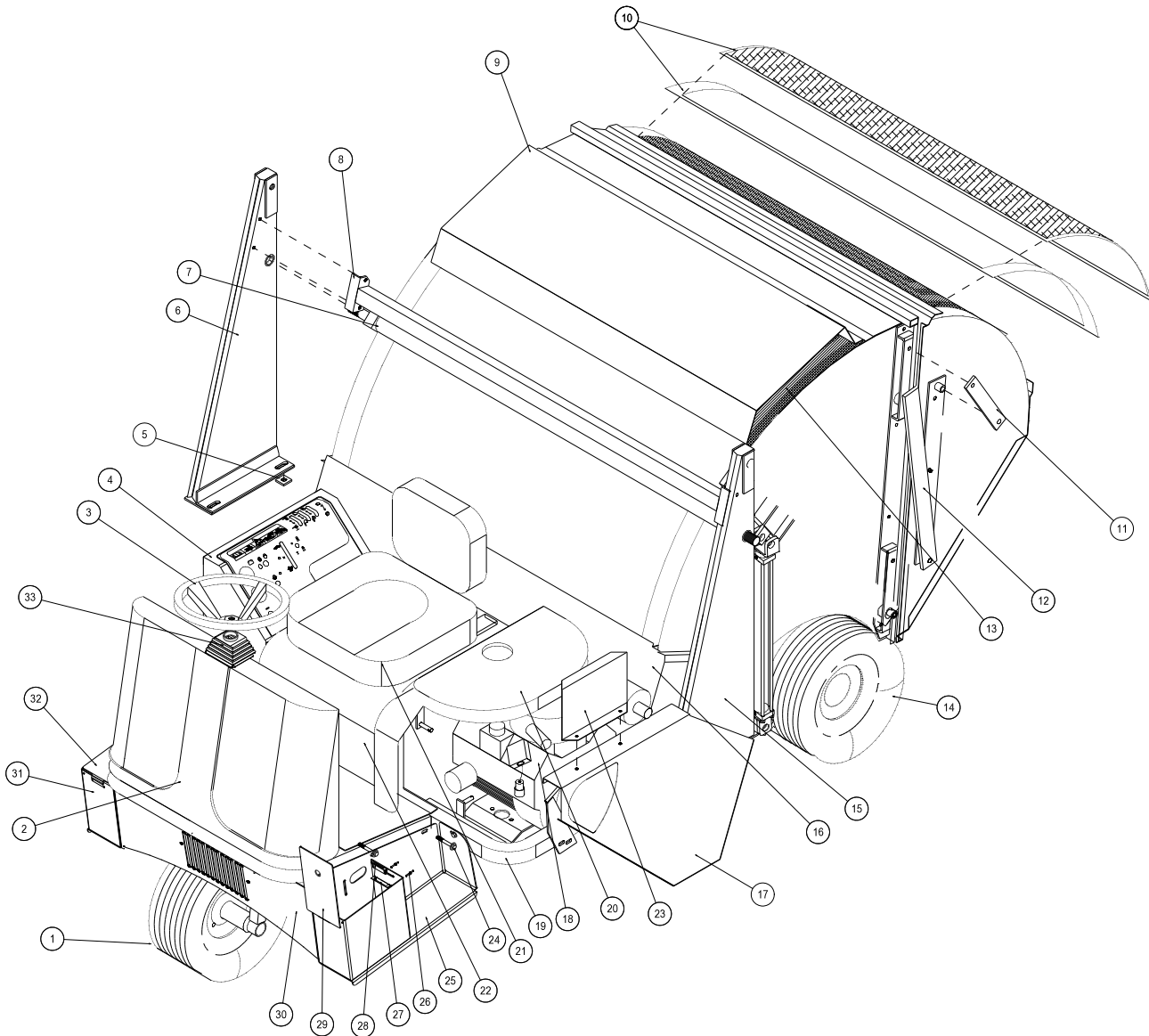

PARTS



# BODY AND FRAME PARTS LIST

REF#	PART#	DESCRIPTION	QUANTITY
1§	60-130	Tire and Wheel	1
	60-130-01	Tire, 18 x 9.50 - 8	1
	60-130-02	Wheel	1
	8839	Windshield Washer Fluid or Equivalent	28 pints
2	76-264	Nose Cone	1
	76-354	2½ # ABC Dry Chemical Fire Extinguisher	1
NS	76-372	Inclinometer	1
NS	76-373	Inclinometer Bracket	1
3	13-718	Steering Wheel	1
4	76-265	Gas Console	1
	77-193	Diesel Console	1
	76-219	Console Support	1
5	76-151	Washer	2
6	75-561	Right Tower	1
7	76-211	Arm Pivot Tube	1
8	75-570	Cross Bar	1
9	76-359	Hopper Screen Cover	1
	HB-516-18-075	Hex Bolt, 5/16 -18 x 3/4	6
	HNTL-516-18	Nylon Lock Nut, 5/16 - 18	6
10*	76-249	Tailgate Filter Screen	1
	76-247	Tailgate Filter Pack	1
11	75-564	Tailgate Hinge	2
12	76-413	Right Tailgate Dump Arm	1
13*	76-248	Hopper Filter Screen	1
	76-246	Hopper Filter Pack	1
14	16-225	Tire and Wheel	2
	16-225-01	Tire, 24 x 13 -12NHS	2
	16-225-02	Wheel	2
15	75-629	Left Tower	1
16	76-235	Grass Chute Frame	1
	8947-60	Trim Seal	2
	8842-14	Foam Tape	2
17	76-758	Belt Guard	1
	13-388	Spacer	2
18	76-636	Briggs & Stratton 35hp Gas Engine	1
	77-208	D-722 Diesel Kubota Engine	1
19	76-290	Main Frame	1
20	76-435	Gas Engine Cover	1
	77-250	Diesel Engine Cover	1
21	14-294	Seat	1
22	76-289	Seat Assembly	1
23	77-180	Belt Guard (diesel only)	1
24	HB-38-16-300	Hex Bolt, 3/8 -16 x 3	6
	HW-38	Flat Washer, 3/8	6
	HNTL-38-16	Nylon Lock Nut, 3/8 - 16	6
25	48-160	Right Step	1
	8803-10	Black Trim, 10"	1
26	HRS-18-050	Rivet, 1/8 x 1/2	4
	HW-6	Flat Washer, #6	4
27	48-164	Magnet	2
28	48-165	Magnet Bracket	2
29	48-159	Battery Box Cover	2
30	76-457	Front Cover	1
31	48-161	Left Step	1
33	76-362	Tilt Steering	1
§	Front tire and wheel fluid filled to 50 lbs. total.		
*	Optional 76-271	Filtration System (includes Ref. 10 and 13)	1
NS	75-703	Tower Washers	2 Per Side

# ROLL-OVER PROTECTION DRAWING

Parts

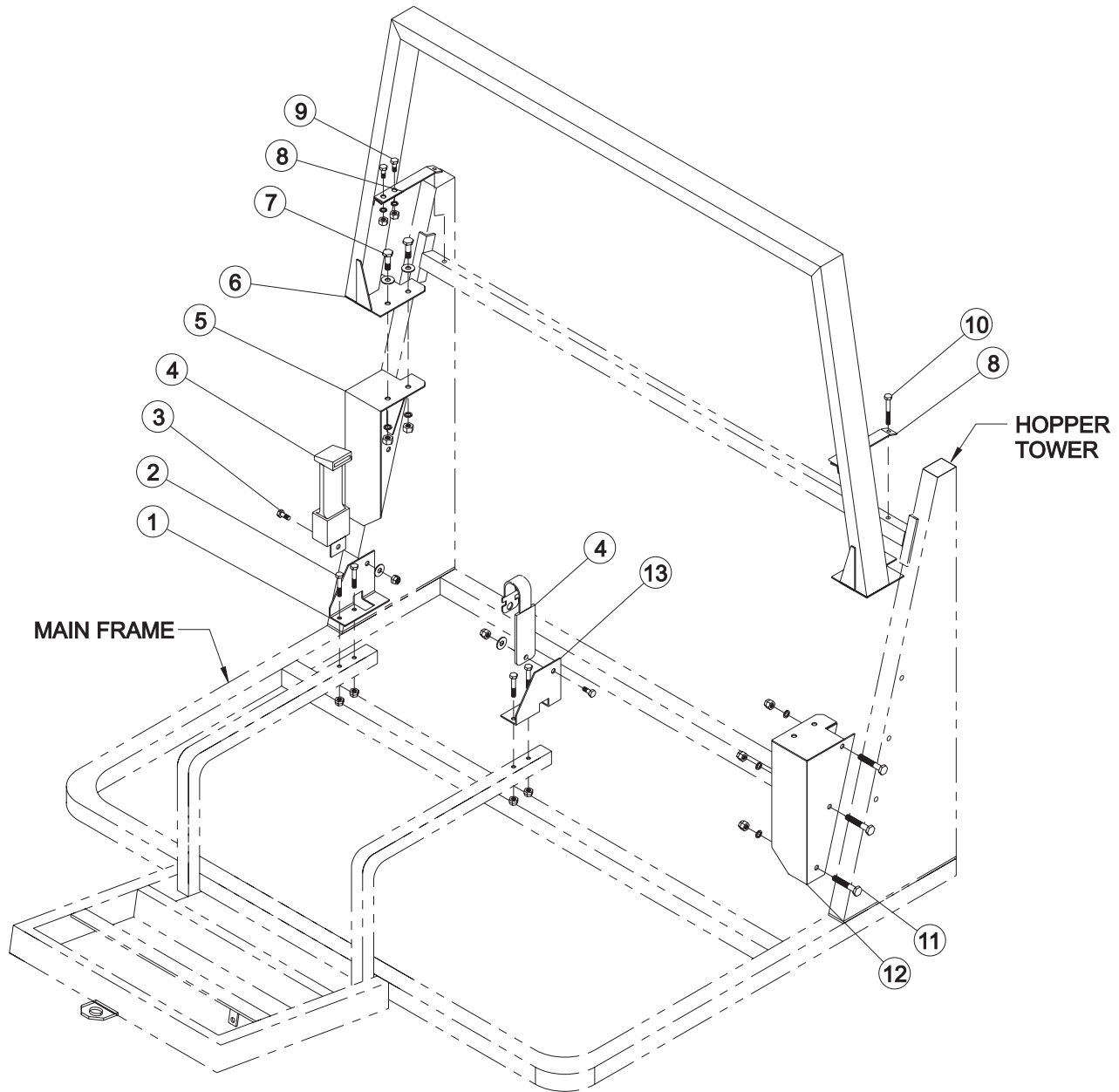

## ROLL-OVER PROTECTION PARTS LIST

REF#	PART#	DESCRIPTION	QUANTITY
1	76-377	Right Seat Belt Bracket	1
2	HB-38-16-200	Hex Bolt, $\frac{3}{8}$ - 16 x 2	4
	HNTL-38-16	Nylon Lock Nut, $\frac{3}{8}$ - 16	4
3	HB-716-14-100	Hex Bolt, $\frac{7}{16}$ - 14 x 1	2
	HNTL-716-14	Nylon Lock Nut, $\frac{7}{16}$ - 14	2
4	76-198-03	Seat Belt	1
5	76-379	Right Support	1
6	76-381	Roll Bar	1
7	HB-12-13-125	Hex Bolt, $\frac{1}{2}$ - 13 x $1\frac{1}{4}$	4
	HW-12	Flat Washer, $\frac{1}{2}$	4
	HWL-12	Lock Washer, $\frac{1}{2}$	4
	HNTL-12-13	Nylon Lock Nut, $\frac{1}{2}$ - 13	4
8	76-376	Strap	2
9	HB-38-16-100	Hex Bolt, $\frac{3}{8}$ - 16 x 1	4
	HWL-38	Lock Washer, $\frac{3}{8}$	4
	HNTL-38-16	Nylon Lock Nut, $\frac{3}{8}$ - 16	4
10	HB-38-16-300	Hex Bolt, $\frac{3}{8}$ - 16 x 3	2
	HWL-38	Lock Washer, $\frac{3}{8}$	2
	HNTL-38-16	Nylon Lock Nut, $\frac{3}{8}$ - 16	2
11	HB-12-13-300	Hex Bolt, $\frac{1}{2}$ - 13 x 3	6
	HNTL-12-13	Nylon Lock Nut, $\frac{1}{2}$ - 13	6
12	76-380	Left Support	1
13	76-378	Left Seat Belt Bracket	1

# STEERING DRAWING

Parts

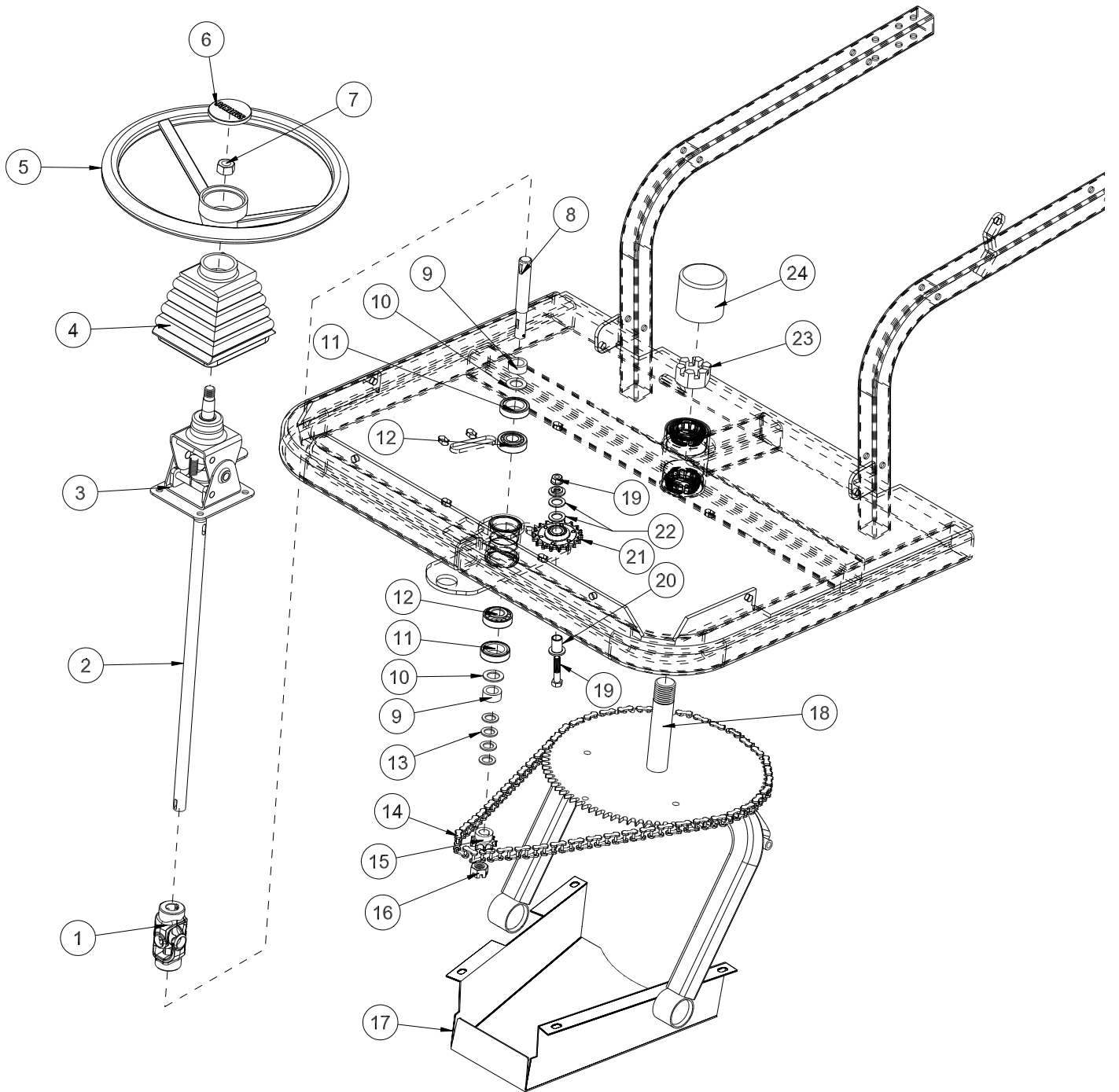

# STEERING PARTS LIST

REF#	PART#	DESCRIPTION	QUANTITY
1	75-833	Universal Joint	1
	HSSHS-516-18-038	Socket Head Set Screw, $\frac{5}{16}$ - 18 x $\frac{3}{8}$	4
2	48-186	Steering Shaft	1
	HWK-316-075	Woodruff Key, $\frac{3}{16}$ x $\frac{3}{4}$	1
3	76-362	Tilt Steering Mechanism	1
4	76-364	Tilt Steering Boot	1
5	13-718	Steering Wheel	1
6	13-726	Steering Wheel Cap	1
7	HN-58-18	Nut, $\frac{5}{8}$ - 18	1
8	75-813	Bottom Steering Shaft	1
	HWK-316-075	Woodruff Key, $\frac{3}{16}$ x $\frac{3}{4}$	1
9	11-040	Spacer, $\frac{3}{4}$	2
10	11-039	Seal	2
11	11-038	Bearing Cup and Cone	2
12	11-038-02	Race	2
13	HMB-58-14	Machine Bushing, $\frac{5}{8}$ - 14	As Req'd
14	8827-59	Roller Chain	1
	18-032	Master Link, #40	1
15	76-153	Sprocket	1
	HWK-316-063	Woodruff Key, $\frac{3}{16}$ - $\frac{5}{8}$	1
16	HNA-58-18	Axle Nut, $\frac{5}{8}$ - 18	1
	HP-18-150	Cotter Pin, $\frac{1}{8}$ x $1\frac{1}{2}$	1
17	75-803	Chain Guard	1
	HSTP-516-18-100	Phillips Truss Machine Screw, $\frac{5}{16}$ - 18 x 1	4
	HNTL-516-18	Nylon Lock Nut, $\frac{5}{16}$ - 18	4
18	76-155	Front Fork	1
19*	HNA-114-12	Axle Nut, $1\frac{1}{4}$ - 12	1
	HP-18-150	Cotter Pin, $\frac{1}{8}$ x $1\frac{1}{2}$	1
20*	18-043	Flange bushing	1
21*	HMB-58-14	Machine Bushing, $\frac{5}{8}$ - 14	2
22*	18-511	Idler Sprocket	1
23	HB-38-16-175	Hex Bolt, $\frac{3}{8}$ - 16 x $1\frac{3}{4}$	1
	HNTL-38-16	Nylon Lock Nut, $\frac{3}{8}$ - 16	1
24	76-301	Rubber Cap	1
*	76-759	Idler Sprocket Kit	

# FRONT FORK DRAWING

Parts

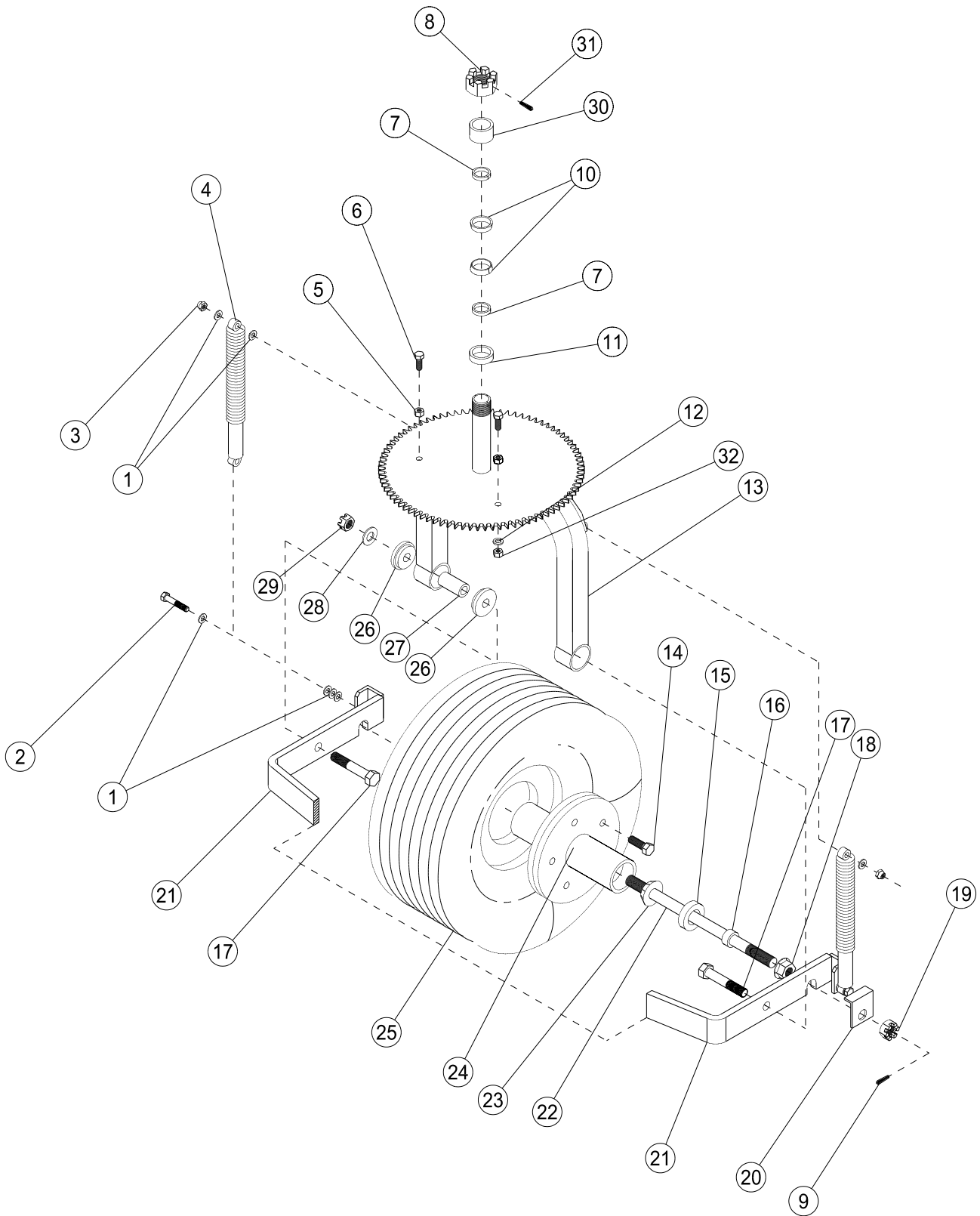

# FRONT FORK PARTS LIST

REF#	PART#	DESCRIPTION	QUANTITY
1	HW-38	Flat Washer, $\frac{3}{8}$ (as Req'd)	14
2	HB-38-16-200	Hex Bolt, $\frac{3}{8}$ - 16 x 2	2
	HNTL-38-16	Nylon Lock Nut, $\frac{3}{8}$ - 16	2
3	HB-38-16-250	Hex Bolt, $\frac{3}{8}$ - 16 x 2 $\frac{1}{2}$	2
	HNTL-38-16	Nylon Lock Nut, $\frac{3}{8}$ - 16	2
4	75-715	Shock Absorber	2
	75-866	Bushing Kit	2 per Shock
5	HN-38-16	Hex Nut, $\frac{3}{8}$ - 16	2
6	HB-38-16-100	Hex Bolt, $\frac{3}{8}$ - 16 x 1	2
7	20-142	Grease Seal, $1\frac{1}{4}$	2
8	HNA-114-12	Axle Nut, $1\frac{1}{4}$ - 12	1
9	HP-18-200	Cotter Pin, $\frac{1}{8}$ x 1	1
10	20-143	Bearing Cup and Cone $1\frac{1}{4}$ ID	2
11	20-141	Spacer	1
12	HWL-38	Lock Washer, $\frac{3}{8}$	2
13	76-155	Front Fork	1
14*	27-022-02	Hex Bolt Stud, $\frac{1}{2}$ - 20 x $1\frac{1}{2}$ (just Hex Bolt; comes with Ref 24)	5
	HNL-12-20	Lug Nut, $\frac{1}{2}$ - 20	5
15*	11-039	Grease Seal, $1\frac{1}{8}$ ID (comes with Ref 24)	2
16	11-040	Spacer	2
17	HBC-58-11-350	Carriage Bolt, $\frac{5}{8}$ - 11 x $3\frac{1}{2}$	2
18	HNJ-34-16	Jam Nut, $\frac{3}{4}$ - 16	2
19	HNA-34-16	Axle Nut, $\frac{3}{4}$ - 16	2
	HMB-34-10	Machine Bushing, $\frac{3}{4}$ x 10GA	2
	HMB-34-14	Machine Bushing, $\frac{3}{4}$ x 14GA	2
20	60-511	Axle Lock	2
21	60-728	U-Bracket Kit	1
22	60-407	Front Axle	1
23*	11-038	Bearing Cup and Cone $\frac{3}{4}$ ID (comes with Ref 24)	2
24	11-010	Wheel Hub (includes * items)	1
25	60-130	Tire & Wheel	1
	60-130-01	Tire, 18 x 9.5 - 8	1
	60-130-02	Wheel	1
	8839	Windshield Washer Fluid or Equivalent	28 pints
26	60-128	Rubber Bushing	4
27	60-406	Spacer	2
28	HW-58	Flat Washer, $\frac{5}{8}$	2
29	HNTL-58-18	Nylon Lock Nut, $\frac{5}{8}$ - 18	1
	HP-18-200	Cotter Pin, $\frac{1}{8}$ x 1	1
30	76-158	Spacer Seal	1
31	HP-18-200	Cotter Pin, $\frac{1}{8}$ x 2	1
32	HNCL-38-16	Center Nylon Lock Nut, $\frac{3}{8}$ - 16	2

Front tire and wheel fluid filled to 50 lbs. total.

# GAS LINKAGE DRAWING

Parts

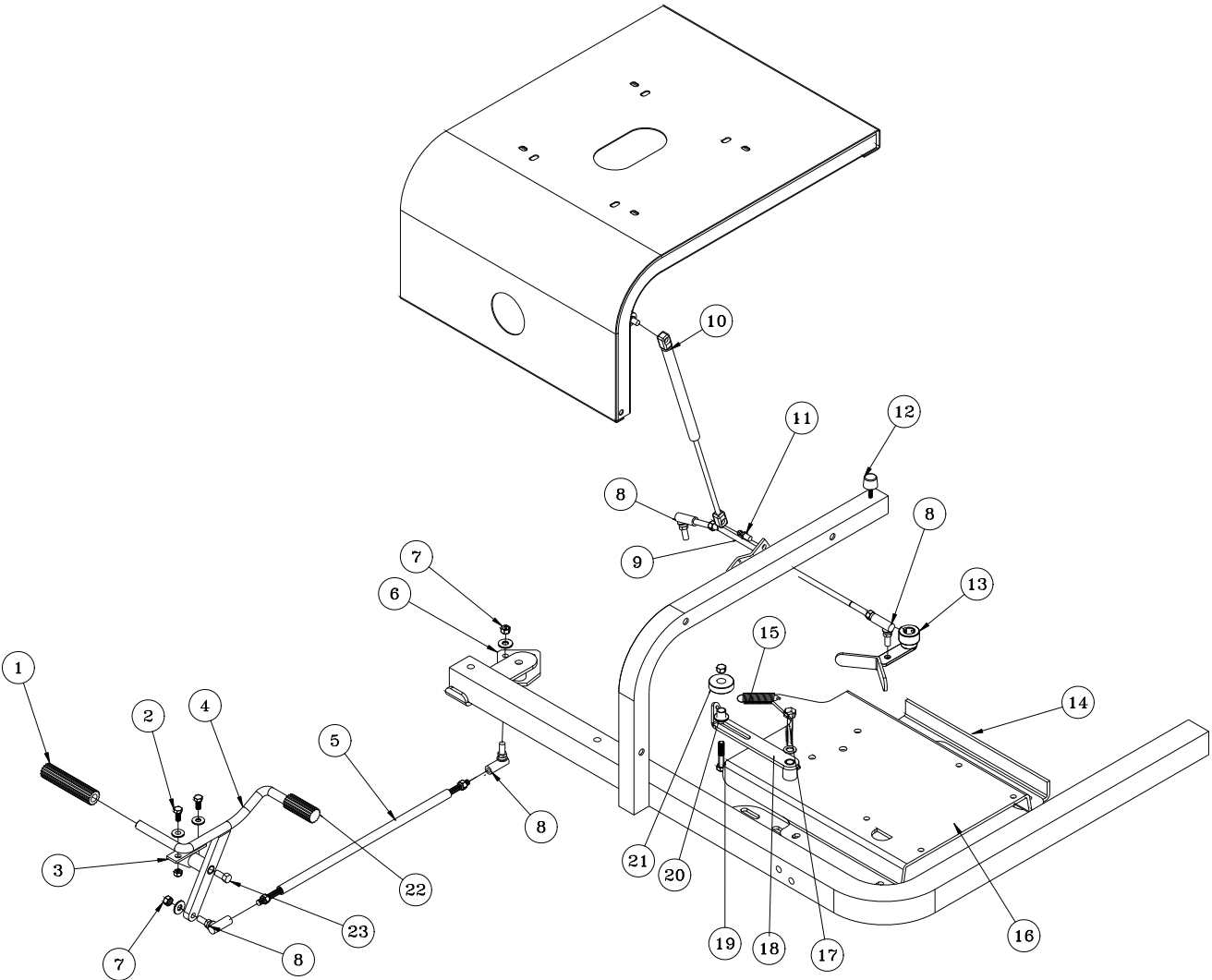



# GAS LINKAGE PARTS LIST

REF#	PART#	DESCRIPTION	QUANTITY
1	76-299	Pedal Pad Long	1
2	HB-516-18-075	Hex Bolt, $\frac{5}{16}$ - 18 x $\frac{3}{4}$	2
	HW-516	Flat Washer, $\frac{5}{16}$	2
	HNTL-516-18	Nylon Lock Nut, $\frac{5}{16}$ - 18	2
3	76-296	Pedal Mount	1
	18-234	Oilite Bushing	2
	HG-14-28-180	Grease Fitting, $\frac{1}{4}$ - 28 x 180°	1
4	48-059	Foot Pedal	1
	18-234	Oilite Bushing	1
5	76-282	Foot Pedal Rod	1
	HN-38-24	Hex Nut, $\frac{3}{8}$ - 24	2
6	75-791	Shift Relay	1
	10-007	Bushing	1
7	HN-38-24	Hex Nut, $\frac{3}{8}$ - 24	4
	HWL-38	Lock Washer, $\frac{3}{8}$	4
8	21-173	Ball Joint, $\frac{3}{8}$ - 24	4
9	76-403	Rear Linkage Rod	1
	HN-38-24	Hex Nut, $\frac{3}{8}$ - 24	2
10	13-569	Gas Spring, 60#	1
11	26-034	Ball Stud	2
12	15-013	Rubber Bumper	2
	HWL-14	Lock Washer, $\frac{1}{8}$	2
	HN-14-20	Hex Nut, $\frac{1}{4}$ - 20	2
13	76-401	Shift Arm	1
	HSSHS-14-28-031	Set Screw, $\frac{1}{4}$ - 28 x $\frac{5}{16}$ (comes with 76-401)	1
14		Mainframe	1
15	48-109	Spring	1
	9019-5.5	$\frac{3}{4}$ " Heat Shrink Tubing x 5.5"	1
16	76-404	Motor Mount	1
17	HB-12-13-275	Hex Bolt, $\frac{1}{2}$ - 13 x $2\frac{3}{4}$	1
	HN-12-13	Hex Nut, $\frac{1}{2}$ - 13	2
	HWL-12	Lock Washer, $\frac{1}{2}$	1
	HMB-12-14	Machine Bushing, $\frac{1}{2}$ x 14GA	2
18	76-402	Idler Arm	1
	18-234	Bushing (part of 76-402)	1
	HG-14-28-180	Grease Fitting, $\frac{1}{4}$ - 28 x 180°	1
19	HB-38-16-200	Hex Bolt, $\frac{3}{8}$ - 16 x 2	1
	HW-38	Flat Washer, $\frac{3}{8}$	2
	HNTL-38-16	Nylon Lock Nut, $\frac{3}{8}$ - 16	1
20	18-270	Oilite Bushing	1
21	14-266	Ball Bearing, $\frac{5}{8}$ ID x $1\frac{3}{4}$ OD	1
22	76-332	Pedal Pad Short	1
23	HB-12-13-250	Hex Bolt, $\frac{1}{2}$ - 13 x $2\frac{1}{2}$	1
	HNTL-12-13	Nylon Lock Nut, $\frac{1}{2}$ - 13	1

# DIESEL LINKAGE DRAWING

Parts

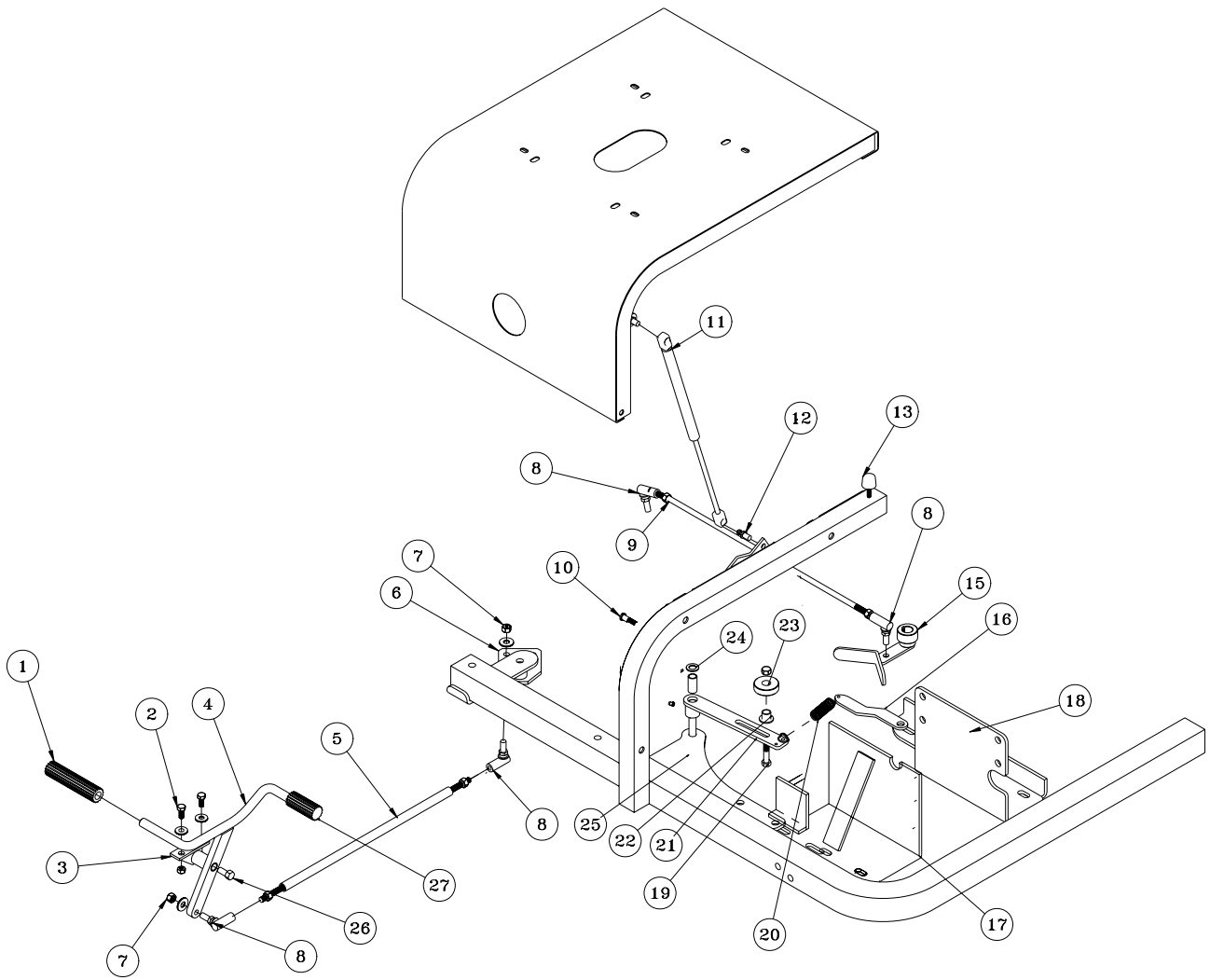

## DIESEL LINKAGE PARTS LIST

REF#	PART#	DESCRIPTION	QUANTITY
1	76-299	Pedal Pad Long	1
2	HB-516-18-075	Hex Bolt, $\frac{5}{16}$ - 18 x $\frac{3}{4}$	2
	HW-516	Flat Washer, $\frac{5}{16}$	2
	HNTL-516-18	Nylon Lock Nut, $\frac{5}{16}$ - 18	2
3	76-296	Pedal Mount	1
	18-234	Oilite Bushing	2
	HG-14-28-180	Grease Fitting, $\frac{1}{4}$ - 28 x 180°	1
4	48-059	Foot Pedal	1
	18-234	Oilite Bushing	1
5	76-282	Foot Pedal Rod	1
	HN-38-24	Hex Nut, $\frac{3}{8}$ - 24	2
6	75-791	Shift Relay	1
	10-007	Bushing	1
7	HN-38-24	Hex Nut, $\frac{3}{8}$ - 24	4
	HWL-38	Lock Washer, $\frac{3}{8}$	4
8	21-173	Ball Joint, $\frac{3}{8}$ - 24	4
9	77-197	Rear Linkage Rod	1
	HN-38-24	Hex Nut, $\frac{3}{8}$ - 24	2
10	HSDPS-14-075	Stainless Steel Pan Head Drill Screw, $\frac{1}{4}$ x $\frac{3}{4}$	1
11	13-569	Gas Spring, 60#	1
12	26-034	Ball Stud	2
13	15-013	Rubber Bumper	2
	HWL-14	Lock Washer, $\frac{1}{4}$	2
	HN-14-20	Hex Nut, $\frac{1}{4}$ - 20	2
15	77-241	Shift Arm	1
	HSSHS-14-28-031	Socket Set Screw, $\frac{1}{4}$ - 28 x $\frac{5}{16}$ (comes with 77-241)	1
16	77-265	Spring Bracket	1
17	77-185	Front Engine Mount	1
18	77-186	Rear Engine Mount	1
19	HB-38-16-200	Hex Bolt, $\frac{3}{8}$ - 16 x 2	1
	HW-38	Flat Washer, $\frac{3}{8}$	2
	HNTL-38-16	Nylon Lock Nut, $\frac{3}{8}$ - 16	1
	22-065	Auxiliary Ground (to back of engine)	1
20	21-445	Spring	1
21	76-370	Idler Arm	1
22	76-275	Spacer	1
23	14-266	Ball Bearing	1
24	HP-18-075	Cotter Pin, $\frac{1}{8}$ x $\frac{3}{4}$	1
	HMB-12-14	Machine Bushing, $\frac{1}{2}$ x 14GA	2
25	76-371	Linkage Plate	1
	HG-14-28-180	Grease Fitting, $\frac{1}{4}$ - 28 x 180°	1
26	HB-12-13-250	Hex Bolt, $\frac{1}{2}$ - 13 x 2 $\frac{1}{2}$	1
	HNTL-12-13	Nylon Lock Nut, $\frac{1}{2}$ - 13	1
27	76-332	Pedal Pad Short	1

# GAS CONSOLE DRAWING

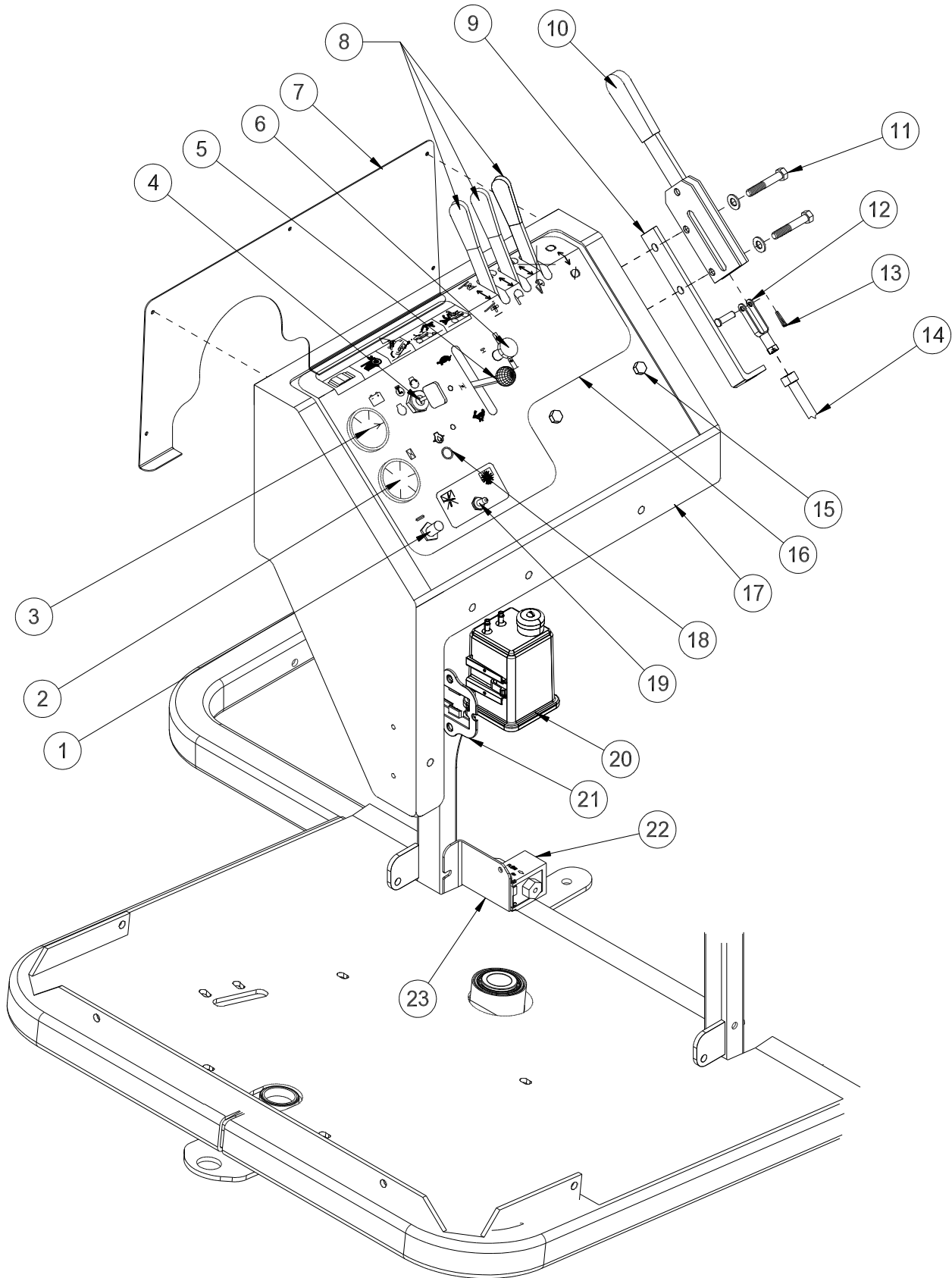

Parts

## GAS CONSOLE PARTS LIST

REF#	PART#	DESCRIPTION	QUANTITY
1	77-261	Circuit Breaker	1
	8977	Circuit Breaker Boot	1
2	12-804	Hour Meter	1
3	76-397	Voltmeter	1
4	13-488	Key Switch	1
	76-310	Key Set	1
5	76-528	Throttle Cable	1
	HSM-10-32-063	Machine Screw, 10 - 32 x 5/8	6
	HWL-10	Lock Washer, 10	6
	HN-10-32	Hex Nut, 10 - 32	6
6	80-020	Choke Cable	1
7	76-479	Side Panel	1
	HSA-8-075	Tapping Screw, #8 x 3/4	4
8	76-309	Valve Handle (with Linkage Kit)	1
	76-023	Hydraulic Valve (3 bank)	1
9	76-224	Park Brake Handle Mount	1
10	60-106	Brake Lever	1
11	HB-516-18-250	Hex Bolt, 5/16 - 18 x 2 1/2	2
	HW-516	Flat Washer, 5/16	6
	HNTL-516-18	Nylon Lock Nut, 5/16 - 18	2
12	11-100	Linkage Yoke, 5/16 (one each end of brake cable)	2
	HN-516-24	Hex Nut, 5/16 - 24	2
13	HP-18-100	Cotter Pin, 1/8 x 1	1
	HCP- 516-100	Clevis Pin, 5/16 x 1	1
14	76-225	Brake Cable (with nuts)	1
	60-536	Bellows (one each end of brake cable)	2
15	HB-38-16-100	Hex Bolt, 3/8 - 16 x 1 (holds 76-023 Valve)	2
	HW-38	Flat Washer, 3/8	2
	HW-516	Flat Washer, 5/16	2
	HNTL-38-16	Nylon Lock Nut, 3/8 - 16	2
16	76-199	Decal, Control Panel	1
17	76-265	Console	1
18	50-359	Warning Indicator Light	1
19	15-314	Electric Clutch Switch	1
	15-472	Switch Boot	1
20	8-689	Carbon Canister	1
21	8-688	Carbon Canister Mount	1
	HSTP-14-20-075	Truss Head Screw, 1/4 -20 x 3/4	2
	HNFL-14-20	Flange Whiz-loc Nut, 1/4 - 20	2
22	76-471	Fuel Pump	1
23	76-470	Pump Bracket	1



# DIESEL CONSOLE DRAWING

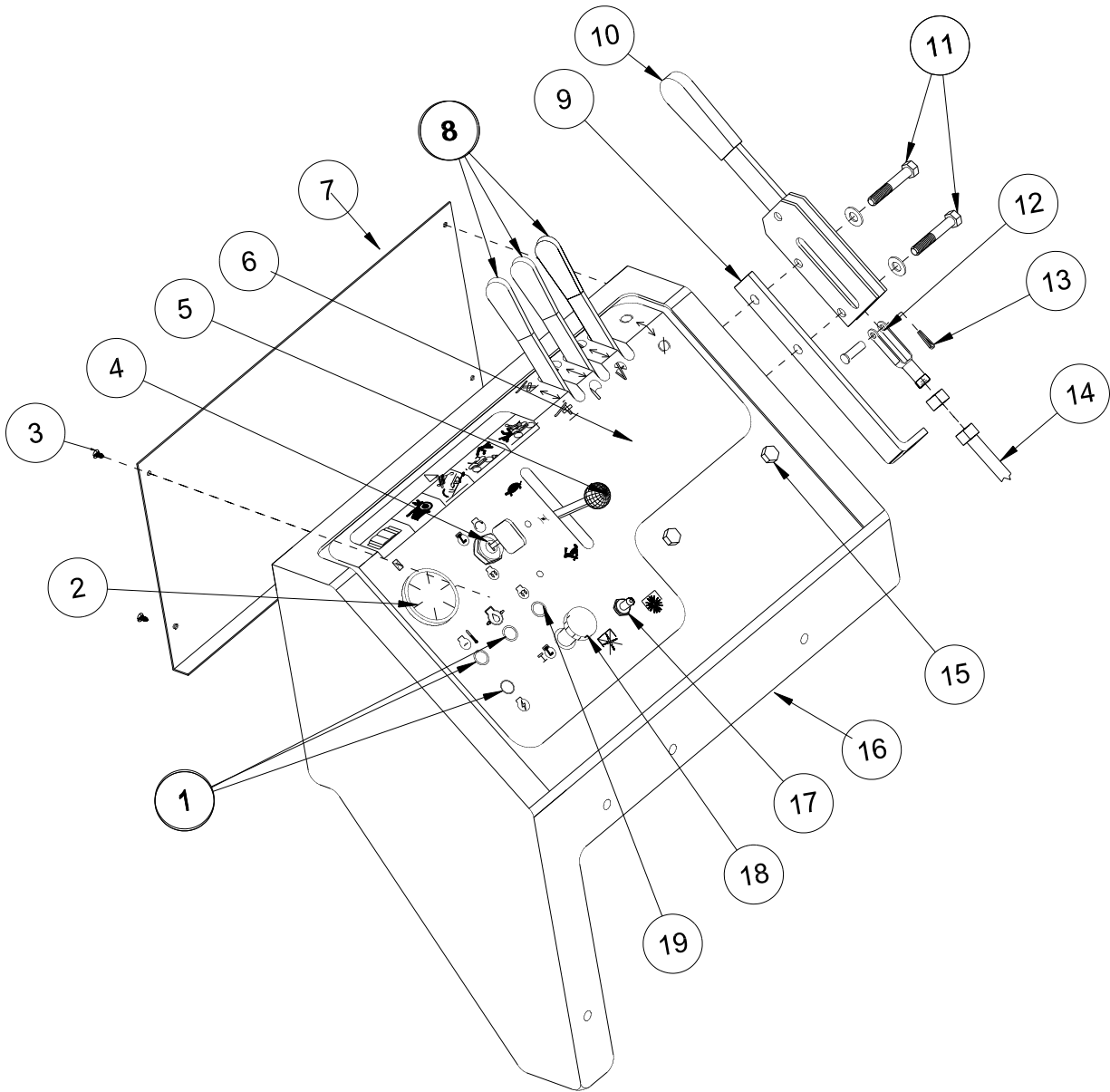

Parts

## DIESEL CONSOLE PARTS LIST

REF#	PART#	DESCRIPTION	QUANTITY
1	50-359	Warning Indicator Light	3
2	12-804	Hour Meter	1
3	HSA-8-075	Tapping Screw, #8 x 3/4	4
4	17-068	Key Switch	1
	17-079	Key Set	1
5	34-160	Throttle, 48"	1
	34-159	Throttle Mounting Bracket	1
	HSM-10-32-063	Machine Screw, 10 - 32 x 5/8	6
	HWL-10	Lock Washer, 10	6
	HN-10-32	Hex Nut, 10 - 32	6
6	77-178	Decal, Control Panel	1
7	76-214	Side Panel	1
8	76-309	Valve Handle (with Linkage Kit)	1
	76-023	Hydraulic Valve (3 bank)	1
9	76-224	Park Brake Handle Mount	1
10	60-106	Brake Lever	1
11	HB-516-18-250	Hex Bolt, 5/16 - 18 x 2 1/2	2
	HW-516	Flat Washer, 5/16	6
	HNTL-516-18	Nylon Lock Nut, 5/16 - 18	2
12	11-100	Linkage Yoke, 5/16	1
	HN-516-24	Hex Nut, 5/16 - 24	2
13	HP-18-100	Cotter Pin, 1/8 x 1	1
	HCP- 516-125	Clevis Pin, 5/16 x 1 1/4	1
14	76-225	Brake Cable (with nuts)	1
	60-536	Bellows (one each end of brake cable)	2
15	HB-38-16-100	Hex Bolt, 3/8 - 16 x 1 (holds 76-023 Valve)	2
	HW-38	Flat Washer, 3/8	2
	HNTL-38-16	Nylon Lock Nut, 3/8 - 16	2
16	77-193	Console	1
17	15-314	Electric Clutch Toggle Switch	1
	15-472	Boot	1
18	77-206	Kill Control	1
	18-275	Ball Joint	1
19	50-359	Glow Plug Indicator Light	1

# GAS TANK AND OIL TANK DRAWING

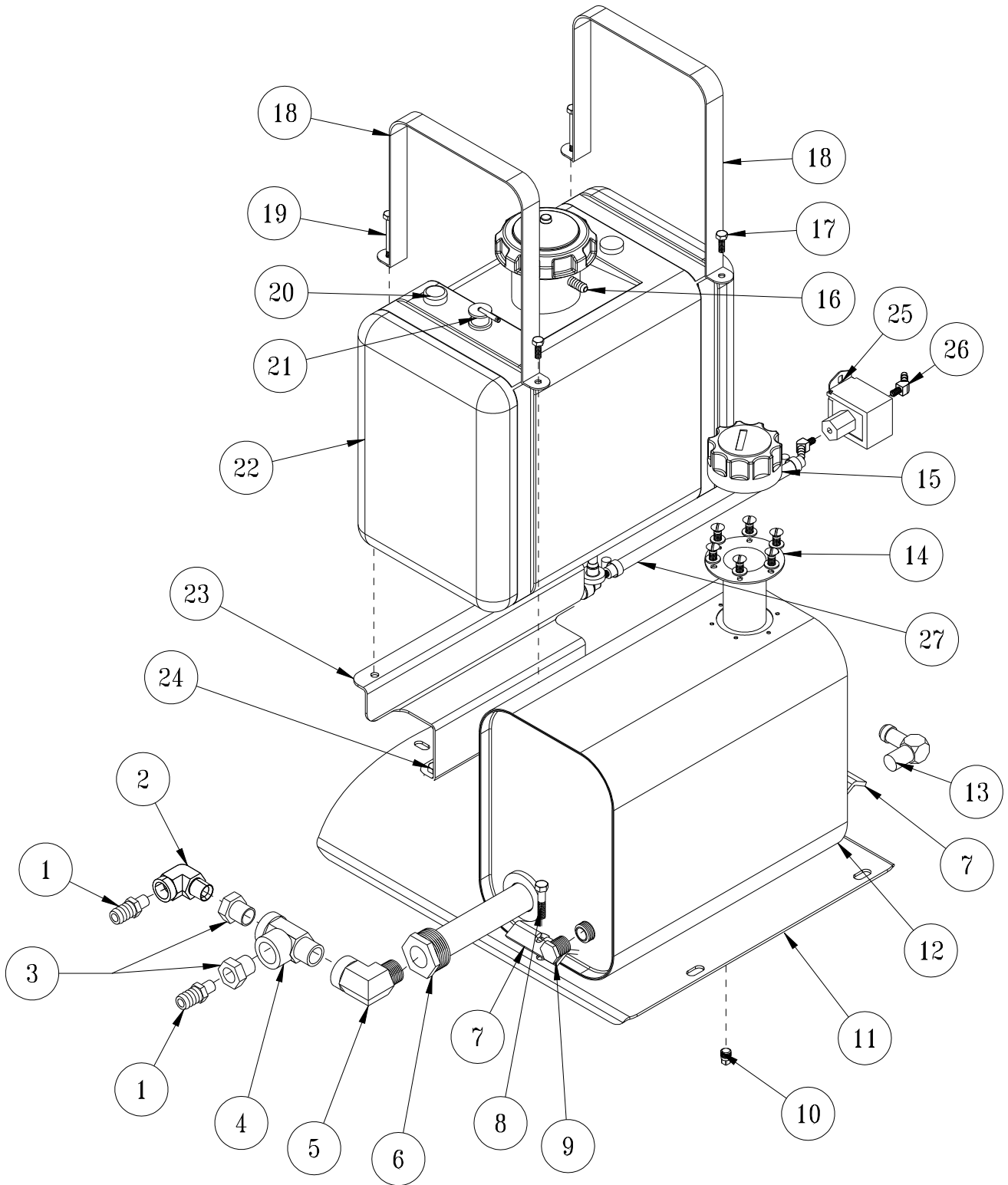

Accessories



## GAS TANK AND OIL TANK PARTS LIST

REF#	PART#	DESCRIPTION	QUANTITY
1	18-133	Barb Fitting	2
2	18-009	Street Elbow	1
3	18-008	Pipe Reducer, $\frac{3}{4}$ x $\frac{1}{2}$	2
4	18-093	Male Run Tee, $\frac{3}{4}$	1
5	18-140	Street Elbow, $\frac{3}{4}$	1
6	60-213	Strainer	1
7	75-792	Mounts	2
8	HB-516-18-150	Hex Bolt, $\frac{5}{16}$ - 18 x $1\frac{1}{2}$	2
	HW-516	Flat Washer, $\frac{5}{16}$	1
	HNTL-516-18	Nylon Lock Nut, $\frac{5}{16}$ - 18	2
9	18-069	Pipe Plug, $\frac{1}{2}$	1
10	18-118	Pipe Plug, $\frac{1}{8}$	1
11	76-477	Tank Mount	1
12	60-473	Oil Tank	1
13	23-142	Connector	1
	18-040	Hose Clamp	1
	8917-38	Suction Hose, $\frac{5}{8}$ ID	1
14	13-586-03	Filler Neck	1
	13-586-02	Bottom Gasket	1
	HSM-10-32-063	Machine Screw	6
	HWL-10	Lock Washer, M10	6
15	13-747	Filler Breather	1
	13-586-01	Cap Gasket	1
16	*	Neck Vent Port	1
	8800-24	Fuel Hose (tank to carb canister)	1
	18-186	Hose Clamp	2
17	HB--14-20-075	Hex Bolt, $\frac{1}{4}$ - 20 x $\frac{3}{4}$	2
	HNTL-14-20	Nylon Lock Nut, $\frac{1}{4}$ - 20	2
18	76-476	Tank Straps	2
19	HB-14-20-250	Hex Bolt, $\frac{1}{4}$ - 20 x $2\frac{1}{2}$	2
	HNTL-14-20	Nylon Lock Nut, $\frac{1}{4}$ - 20	2
20	15-838-01	Dial Fuel Level Gauge	1
21	*	Top Draw	1
	8800-77	Fuel Hose (tank to engine)	1
	18-186	Hose Clamp	2
22	15-838	CARB Gas Tank (includes all * items)	1
	73-050	Vented Cap With Gauge	1
	50-403	Inline Fuel Filter	1
23	76-475	Tank Brackets	2
24	HB-516-18-100	Hex Bolt, $\frac{5}{16}$ - 18 x 1	4
	HNTL-516-18	Nylon Lock Nut, $\frac{5}{16}$ - 18	4
25	76-471	Fuel Pump	1
26	18-420	Hose Barb	2
27	8800-22.5	$\frac{1}{4}$ " Fuel Hose x 22.5"	1
	18-186	Hose Clamp	2

# DIESEL FUEL TANK AND OIL TANK DRAWING

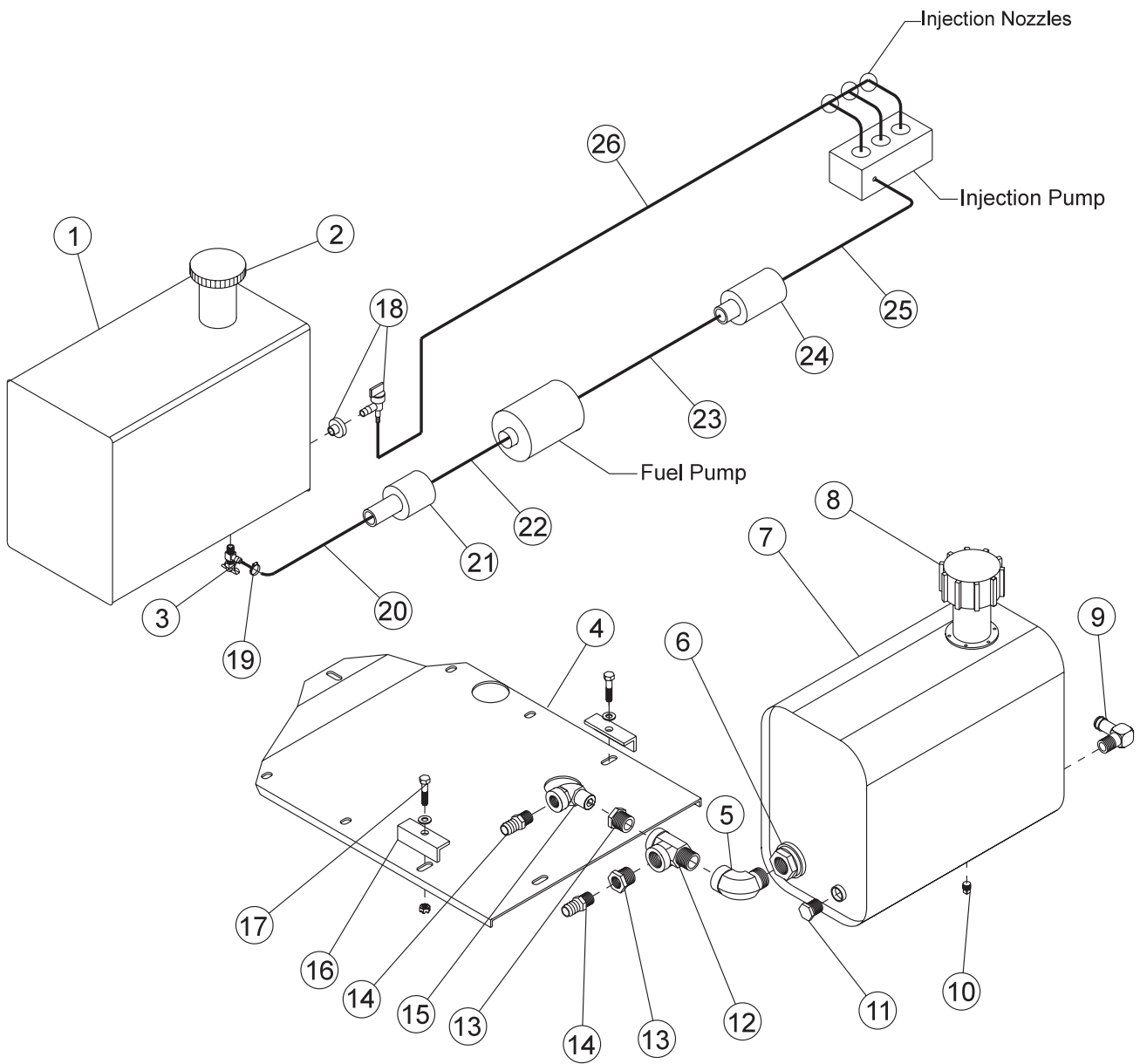

Parts

## DIESEL FUEL TANK AND OIL TANK PARTS LIST

REF#	PART#	DESCRIPTION	QUANTITY
1	15-491	Fuel Tank	1
	HB 14-20-075	Hex Bolt, $\frac{1}{4}$ - 20 x $\frac{3}{4}$	4
	HWL-14	Lock Washer, $\frac{1}{4}$	4
	HW-14	Flat Washer, $\frac{1}{4}$	4
2	15-492	Gas Cap with Gauge	1
	77-179	Diesel Fuel Cap with Gauge	1
3	15-039	Fuel Valve	1
	18-042	Reducer Bushing, $\frac{1}{4}$ x $\frac{1}{8}$	1
4	76-221	Tank Mount	1
5	18-140	Street Elbow	1
6	60-213	Strainer	1
7	60-473	Oil Tank (includes * items)	1
8	13-747	Filler Breather	1
	13-586-03	Neck	1
	HSM-10-32-063	Machine Screw	6
	HWL-10	Lock Washer, M10	6
9	23-142	Connector	1
	18-040	Hose Clamp	1
	8917-38	Suction Hose, $\frac{5}{8}$ ID	1
10*	18-118	Pipe Plug, $\frac{1}{8}$	1
11*	18-069	Pipe Plug, $\frac{1}{2}$	1
12	18-093	$\frac{3}{4}$ " Male Run Tee	1
13	18-008	Pipe Reducer, $\frac{3}{4}$ x $\frac{1}{2}$	2
14	18-133	Barb Fitting	2
15	18-009	Street Elbow, $\frac{1}{2}$	1
16	75-792	Mounts	2
17	HB-516-18-150	Hex Bolt, $\frac{5}{16}$ - 18 x $1\frac{1}{2}$	2
	HW-516	Flat Washer, $\frac{5}{16}$	1
	HNTL-516-18	Nylon Lock Nut, $\frac{5}{16}$ - 18	2
18	26-054	Bushing Insert (part of tank)	1
	26-055	Shut-Off Valve (part of tank)	1
19	18-186	Hose Clamp, $\frac{7}{32}$ - $\frac{5}{8}$	10
20	8800-14	Fuel Hose, $\frac{1}{4}$ " x 14"	1
21	50-403	In-Line Fuel Filter	1
22	8800-49	Fuel Hose, $\frac{1}{4}$ " x 49"	1
23	8800-16	Fuel Hose, $\frac{1}{4}$ " x 16"	1
24	77-214	Fuel Filter Assembly (part of engine)	1
	17-043	Fuel Filter Element (part of engine)	1
25	8800-11	Fuel Hose, $\frac{1}{4}$ " x 11"	1
26	8800-51	Fuel Hose, $\frac{1}{4}$ " x 51"	1

# OIL FILTER DRAWING

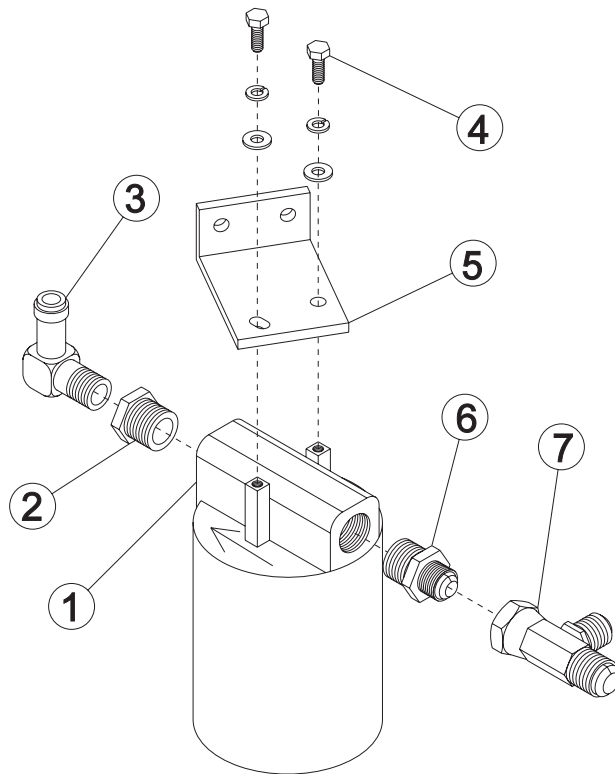

# HYDRAULIC LIFT CYLINDER DRAWING

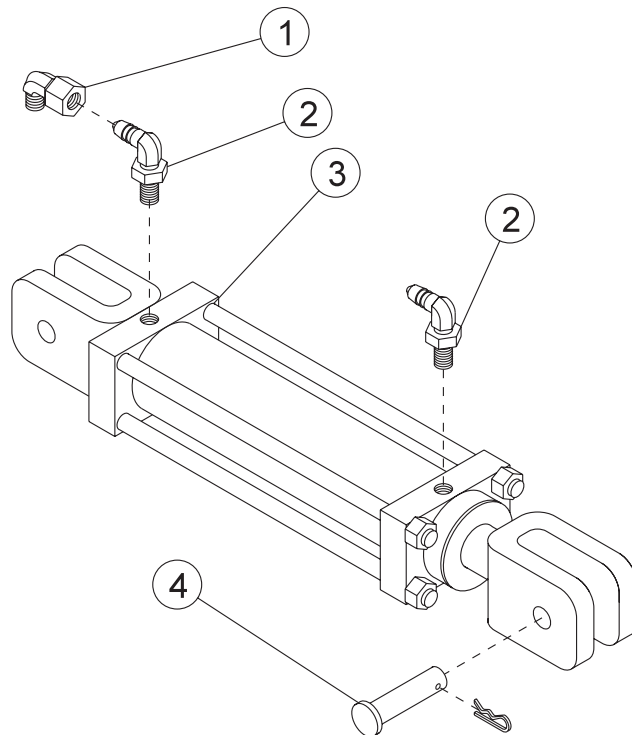

## OIL FILTER PARTS LIST

REF#	PART#	DESCRIPTION	QUANTITY
1	23-006	Oil Filter	1
	23-031	Filter Element (replacement only)	1
2	18-008	Pipe Reducer, $\frac{3}{4}$ x $\frac{1}{2}$	1
3	23-142	Connector	1
4	HB-14-20-075	Hex Bolt, $\frac{1}{4}$ - 20 x $\frac{3}{4}$	2
	HWL-14	Lock Washer, $\frac{1}{4}$	2
	HW-14	Flat Washer, $\frac{1}{4}$	2
5	75-806	Filter Bracket	1
6	23-183	Male Connector	1
7	18-190	Tee	1

## HYDRAULIC LIFT CYLINDER PARTS LIST

REF#	PART#	DESCRIPTION	QUANTITY
1	18-202	Elbow	1
2	23-167	Elbow	2
3	76-627	Hydraulic Cylinder	1
	76-242-01	Seal Kit	1
4	HCP-100-325	Clevis Pin, 1 x $3\frac{1}{4}$	1
	HHP-.177	Bridge Pin	1

### Torque Specification

Piston Nut	165 ft/lbs (214.5 Nm)
Tie Rod Nut	30 ft/lbs (39 Nm)
Clevis Nut	46 ft/lbs (59.8 Nm)

# REEL LIFT CYLINDER DRAWING

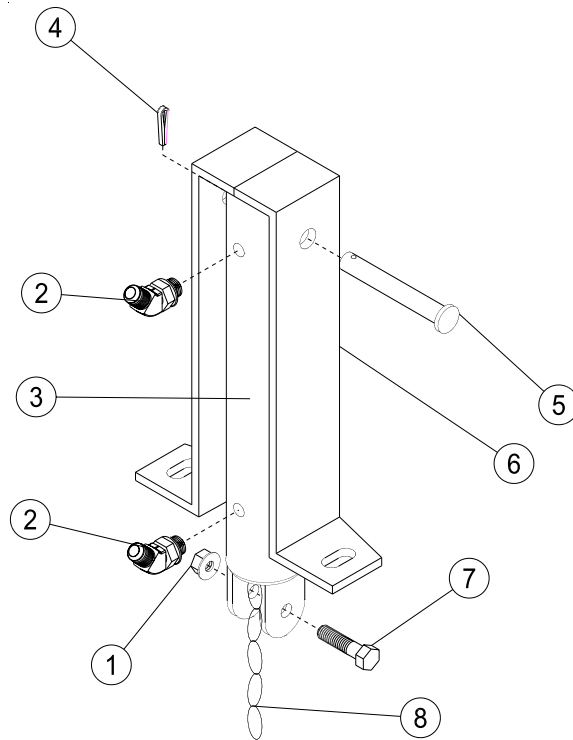

# TAILGATE CYLINDER DRAWING

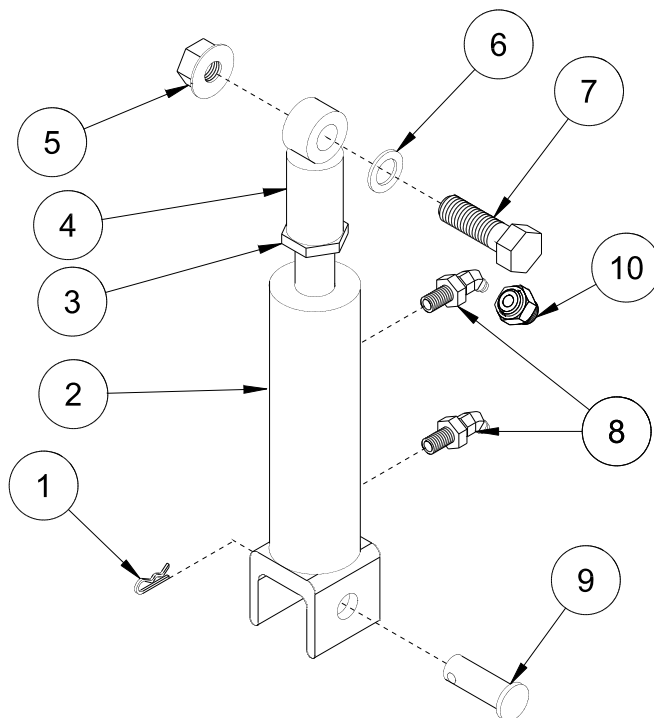

## REEL LIFT CYLINDER PARTS LIST

REF#	PART#	DESCRIPTION	QUANTITY
1	HNTL-38-16	Nylon Lock Nut, $\frac{3}{8}$ - 16	2
2	18-188	Elbow, $\frac{3}{8}$ SAE	2
3	76-478	Hydraulic Cylinder, 2 x 7 x $\frac{3}{4}$	1
	14-531	Seal Kit	
4	HP-18-100	Cotter Pin, $\frac{1}{8}$ x 1	1
5	HCP-12-350	Clevis Pin, $\frac{1}{2}$ - 3 $\frac{1}{2}$	1
6	75-827	Cylinder Bracket	1
7	HB-38-16-150	Hex Bolt, $\frac{3}{8}$ - 16 x 1 $\frac{1}{2}$	1
8	8820-8	Machine Chain St. Link	1

## TAILGATE CYLINDER PARTS LIST

REF#	PART#	DESCRIPTION	QUANTITY
1	HHP-18	Bridge Pin, $\frac{1}{8}$	1
2	77-263	Hydraulic Cylinder, 1 $\frac{1}{2}$ x 7	1
	14-530	Seal Kit	1
3	HNJ-58-18	Jam Nut, $\frac{5}{8}$ - 18	1
4	18-154	Rod End	1
	HG-14-28-180	Grease Fitting, $\frac{1}{4}$ - 28 x 180°	1
5	HNTL-58-11	Nylon Lock Nut, $\frac{5}{8}$ - 11GA	1
6	HMB-58-14	Machine Bushing, $\frac{5}{8}$ - 14GA	1
7	HB-58-11-200	Hex Bolt, $\frac{5}{8}$ - 11 x 2	1
8	18-168	Elbow	2
9	HCP-58-150	Clevis Pin, $\frac{5}{8}$ x 1 $\frac{1}{2}$	1
10	18-392	Orifice Fitting	1

# GAS ENGINE AND EXHAUST DRAWING

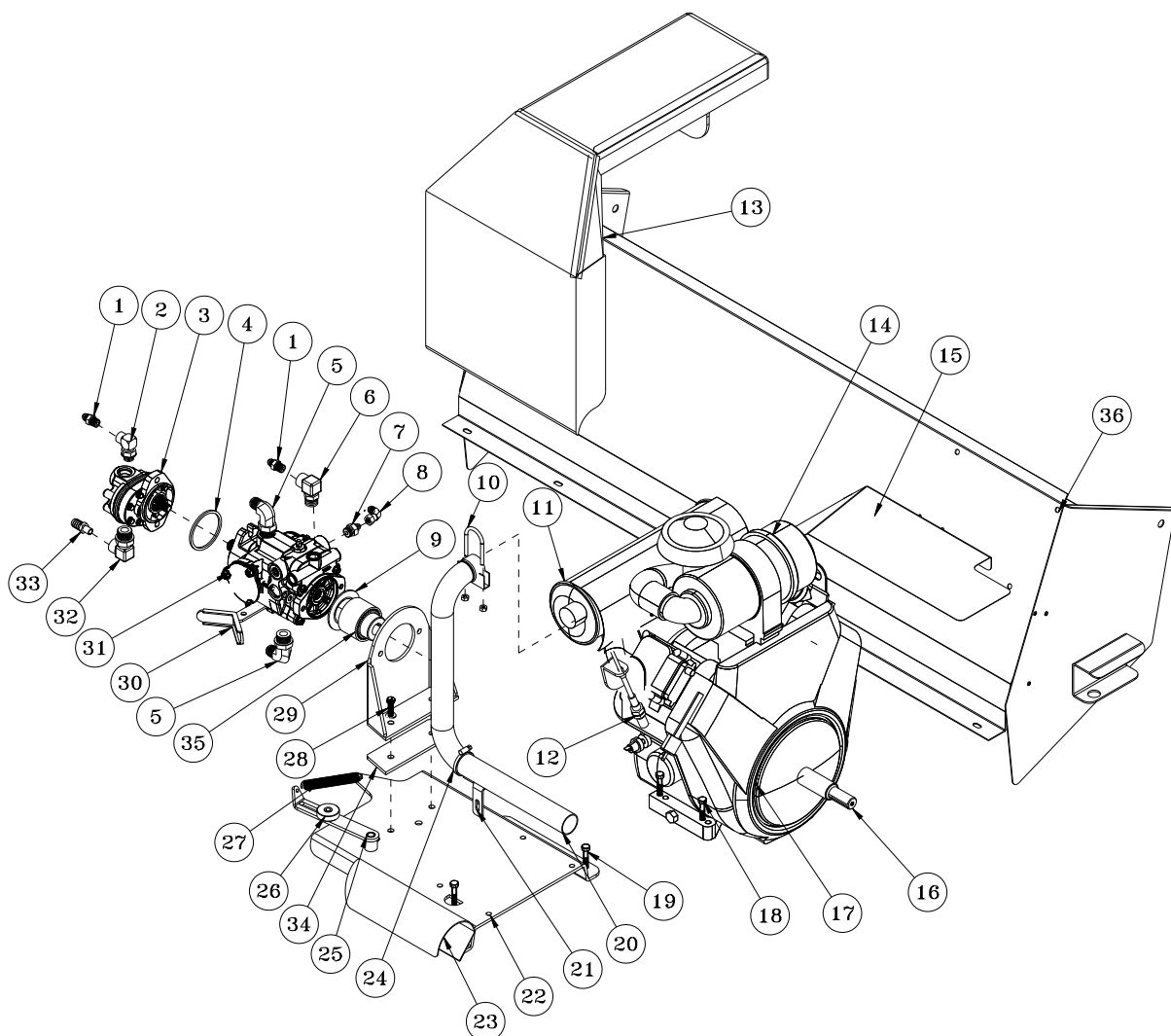

## Cyclonic air cleaner 76-395-04

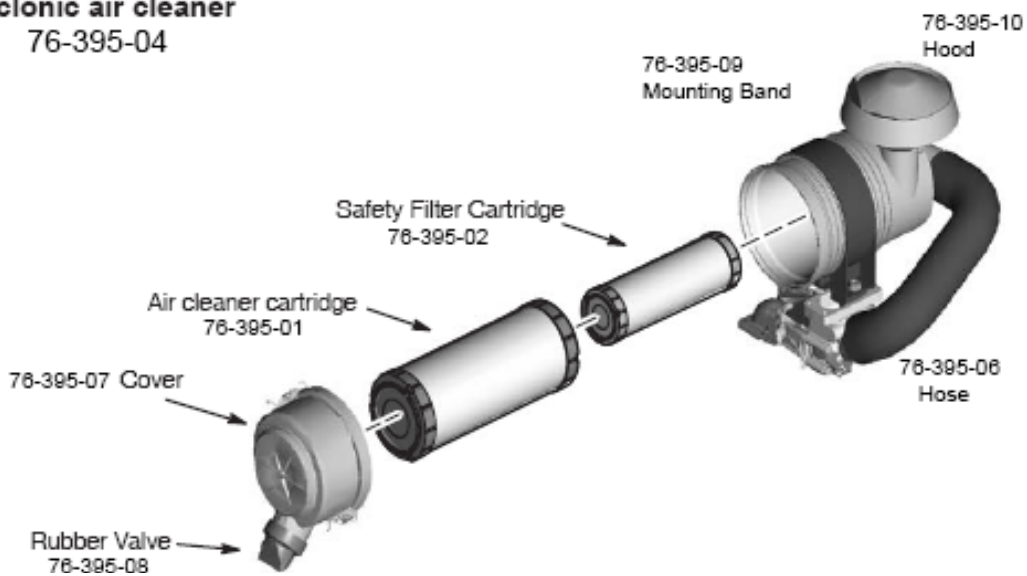



# GAS ENGINE AND EXHAUST PARTS LIST

REF#	PART#	DESCRIPTION	QUANTITY
1	18-133	Barb Fitting	2
2	23-133	Adjustable Elbow, 90°	1
3	76-197	Gear Pump	1
4	23-145	O-Ring, 3¼ ID x 3¾ OD	1
5	18-204	Elbow, 90°	2
6	23-130	Elbow, 90°	1
7	18-241	Straight Thread Connector	1
8	18-202	Elbow	1
9	76-465	Pump Coupling Complete	1
10	50-394	Muffler Clamp	1
11	76-448	Muffler	1
12	76-528	Throttle Cable	1
13	76-435	Engine Cover (Fiberglass)	1
	76-463	Foil Face Insulation, 15.5" x 15"	1
	76-464	Foil Face Insulation, 19.5" x 22.5"	1
14	76-395-04	Cyclonic Air Cleaner	1
	76-395-01	Air Cleaner Cartridge	1
	76-395-02	Safety Filter Cartridge	1
15	76-405	Debris Shield	1
16	76-411	Stub Shaft	1
17	76-636	35HP Briggs & Stratton Engine	1
	8983-6	Fire Sleeve	1
	18-222	Hose Clamp	1
	21-161	Wire Block	1
18	HB-516-18-200	Hex Bolt, 5/16 - 18 x 2	4
	HNTL-516-18	Nylon Lock Nut, 5/16 - 18	4
19	HB-38-16-125	Hex Bolt, 3/8 - 16 x 1¼	4
	HNTL-38-16	Nylon Lock Nut, 3/8 - 16	4
20	76-396	Tailpipe	1
21	76-436	Tailpipe Bracket	1
22	76-404	Motor Mount	1
23	76-410	Tailpipe Shield	1
24	18-116	Hose Clamp	1
25	76-370	Idler Arm	1
26	14-266	Ball Bearing	1
27	48-109	Spring	1
28	HB-38-16-125	Hex Bolt, 3/8 - 16 x 1¼	2
	HW-38	Flat Washer, 3/8	4
	HNTL-38-16	Nylon Lock Nut, 3/8 - 16	2
29	76-407	Pump Mount	1
30	76-401	Shift Arm	1
31	76-638	Hydrostatic Pump	1
	HB-38-16-150	Hex Bolt, 3/8 - 16 x 1½	2
	HW-38	Flat Washer, 3/8	2
	HWL-38	Lock Washer, 3/8	2
32	23-129	Elbow 90°	1
33	23-188	Male Connector, 3/8	1
34	76-637	Pump Mount Shim	1
35	76-466	7/8" Coupling Half	1
	76-467	1 1/8" Coupling Half	1
	76-468	Sleeve, M42	1
36	76-235	Grass Chute Frame	1
	8947-60	Trim Seal	2
	8842-14	Foam Tape	2
NS	76-757	Fuel Pump	1

# KUBOTA DIESEL ENGINE AND EXHAUST DRAWING

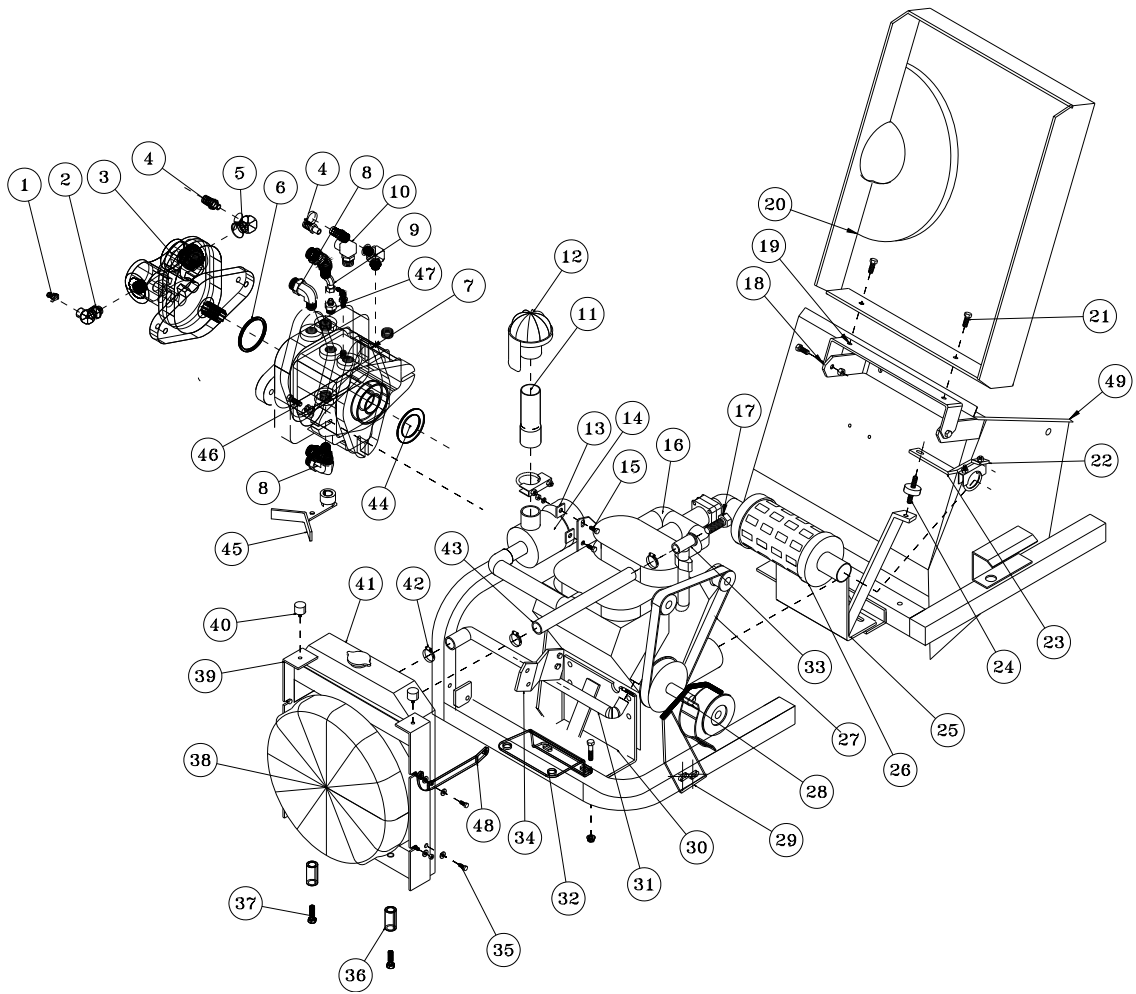

Parts

# KUBOTA DIESEL ENGINE AND EXHAUST PARTS LIST

REF#	PART#	DESCRIPTION	QUANTITY
1	23-188	Male Connector, $\frac{3}{8}$	1
2	23-129	Elbow, 90°	1
3	76-197	Gear Pump	1
4	18-133	Barb Fitting	2
5	23-133	Adjustable Elbow, 90°	1
6	23-145	O-Ring	1
7	77-266	Hydrostatic Pump	1
8	18-204	Elbow 90°	2
9	18-202	Elbow	1
10	23-130	Elbow, 90°	1
11	77-249	Diesel Air Intake	1
12	42-004-02	Filter Head	1
13	11-132	Mounting Band (part of engine)	1
	HB-14-20-075	Hex Bolt, $\frac{1}{4}$ - 20 x $\frac{3}{4}$	2
	HWL-14	Lock Washer, $\frac{1}{4}$	2
	HN-14-20	Hex Nut, $\frac{1}{4}$ - 20	2
14†	77-213	Air Cleaner Element (Steel Canister)	1
	42-076-03	Air Cleaner Element (Plastic Canister)	1
15	77-248	Air Cleaner Mount	1
	HSD-8-50	Drill Screw, #8 - 50	2
16	77-208	D-722 Diesel Kubota Engine	1
	77-208-02	Pump Housing	1
	77-208-03	Drive Shaft	1
	22-065	Auxiliary Ground	1
17*	77-208-05	Air Pack Switch (part of engine)	1
18	77-182	Hood Hinge Mount	1
	HB-38-16-100	Hex Bolt, $\frac{3}{8}$ - 16 x 1	4
	HNTL -38-16	Nylon Lock Nut, $\frac{3}{8}$ - 16	4
19	77-236	Hood Hinge	1
20	77-250	Engine Cover	1
	15-437	Latch	1
21	HB-38-16-100	Hex Bolt, $\frac{3}{8}$ - 16 x 1	2
	HN-38-16	Hex Nut, $\frac{3}{8}$ - 16	2
22	50-111	Muffler Clamp, $1\frac{1}{2}$	1
23	77-192	Muffler Brace	1
24	11-021	Rubber Mount	1
25	77-186	Rear Engine Mount	1
	HB-38-16-175	Hex Bolt, $\frac{3}{8}$ - 16 x $1\frac{3}{4}$	2
	HNTL-38-16	Nylon Lock Nut, $\frac{3}{8}$ - 16	2
26	77-216	Muffler Assembly (part of engine)	1
	77-217	Muffler Gasket (part of engine)	1
27	77-212	Fan Belt (part of engine)	1
28	HWK-14-100	Woodruff Key, $\frac{1}{4}$ x 1	1
	77-242	Stub Shaft	1
	HWLI-516	Internal Lock Washer, $\frac{5}{16}$	3
	HSSHSM-8-1.25-20	Socket Set Cap Screw Metric, 8 - 1.25 x 20	3
29		Main Frame	1
*	77-235	Thermostat Kit (includes * items)	
†	77-221	Air Cleaner Assembly	

(Continued on Next Page)

# KUBOTA DIESEL ENGINE AND EXHAUST DRAWING (CONTINUED)

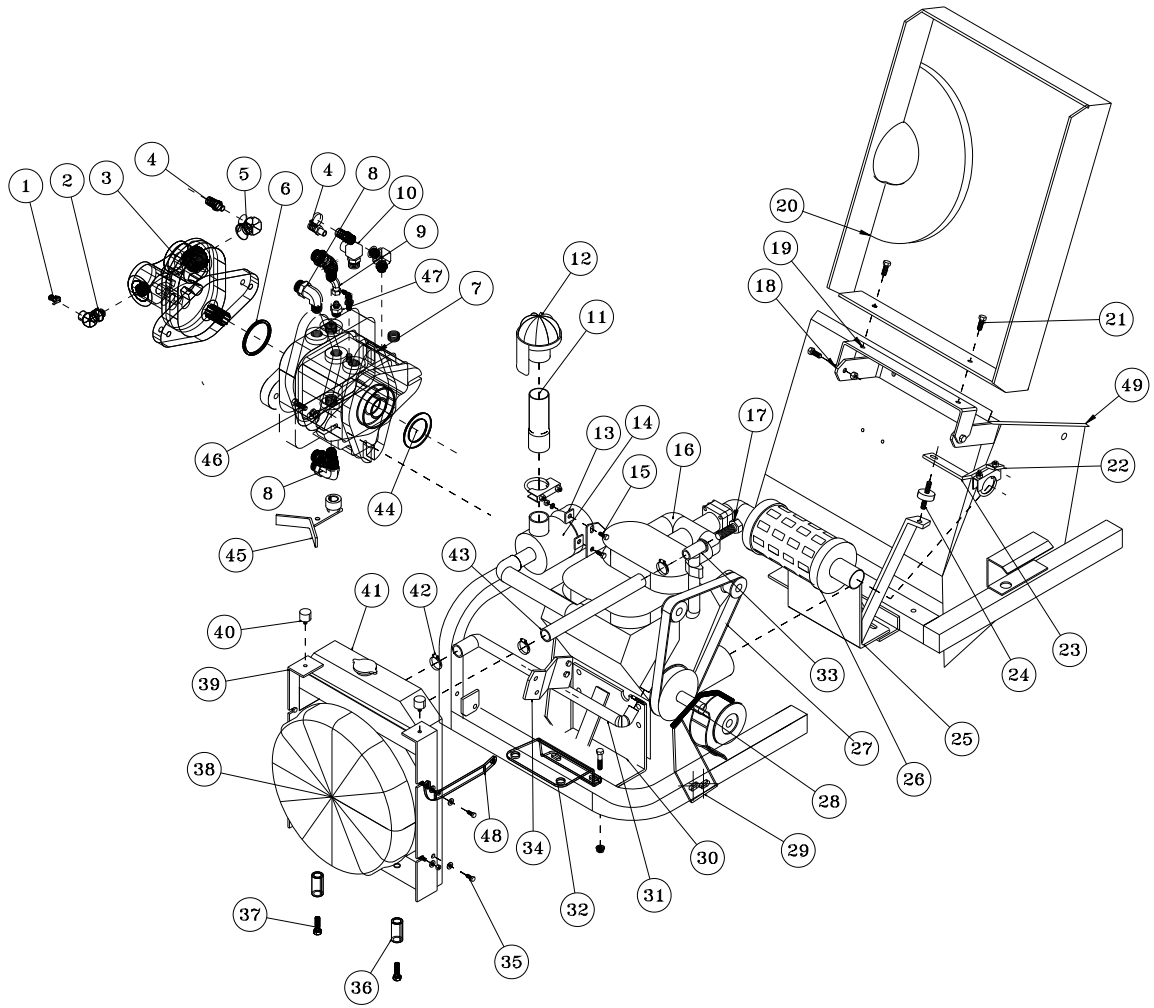

Parts

## KUBOTA DIESEL ENGINE AND EXHAUST PARTS LIST (CONTINUED)

REF#	PART#	DESCRIPTION	QUANTITY
30	77-185	Front Engine Mount	1
	HB-38-16-175	Hex Bolt, $\frac{3}{8}$ - 16 x $1\frac{3}{4}$	2
	HNTL-38-16	Nylon Lock Nut, $\frac{3}{8}$ - 16	2
31	8951-24	Lower Radiator Hose	1
32	77-243	Radiator Mount	1
33*	77-208-04	Goose Neck (part of engine)	1
34	77-184	Cable Bracket	1
	HBM-8-1.25 x 20	Metric Hex Bolt, #8 - 1.25 x 20	1
35	HBM-6-1-16	Metric Hex Bolt, #6 - 1 - 16	3
	HBM-6-1-20	Metric Hex Bolt, #6 - 1 - 20	1
	HW-14	Flat Washer, $\frac{1}{4}$	4
	HWLM-6	Metric Lock Washer, #6	4
36	60-406	Spacer	2
37	HBM-10-1.25-110	Metric Hex Bolt, 10 - 1.25 x 110	2
38	77-201	Electric Fan	1
39	77-238	Radiator Mount	1
	15-437	Latch	1
40	15-013	Rubber Bumper	2
	HWL-14	Lock Washer, $\frac{1}{4}$	2
	HN-14-20	Hex Nut, $\frac{1}{4}$ - 20	2
41	77-210	Radiator (on engine)	1
42	18-222	Hose Clamp, $\frac{13}{16}$ to $1\frac{1}{2}$	4
43	8951-11.5	Upper Radiator Hose	1
44	23-145	O-Ring, $3\frac{1}{4}$ ID x $3\frac{3}{8}$ OD	1
	77-208-06	Coupler	1
	77-208-07	Flange. Polymer	1
45	77-241	Shift Arm	1
	HSSHS-516-18-050	Socket Head Set Screw $\frac{5}{16}$ - 18 x $\frac{1}{2}$	1
46	HB-38-16-125	Hex Bolt, $\frac{3}{8}$ - 16 x $1\frac{1}{4}$	2
-	HW-38	Flat Washer, $\frac{3}{8}$	2
	HWL-38	Lock Washer, $\frac{3}{8}$	2
47	18-241	Straight Thread Connector	1
48	77-237	Radiator Brace	1
49	76-235	Grass Chute Frame	1
	8947-60	Trim Seal	2
	8842-14	Foam Tape	2
*	77-235	Thermostat Kit (includes * items)	

# ELECTRIC CLUTCH DRIVEN BELT DRIVE DRAWING

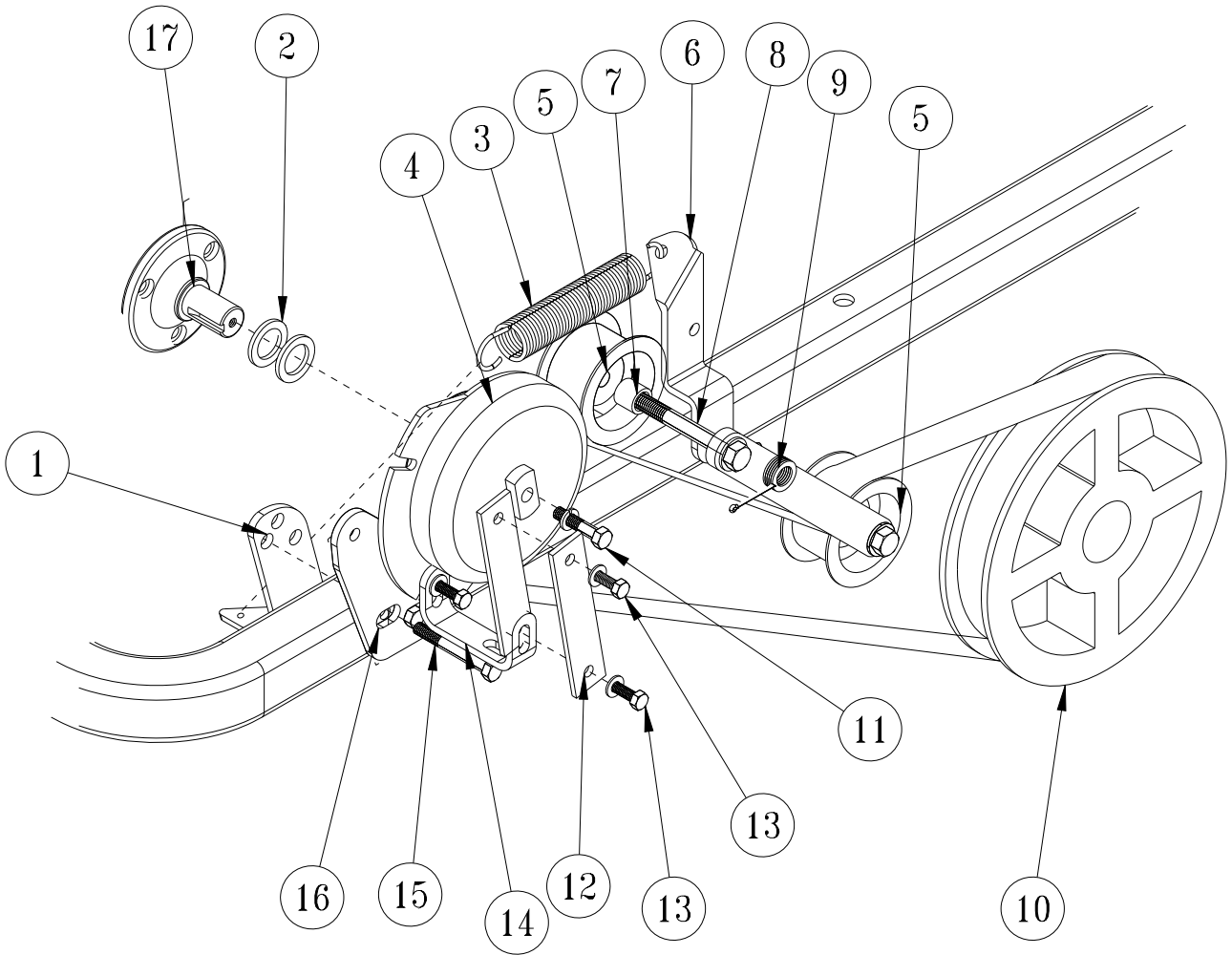

Parts

## ELECTRIC CLUTCH DRIVEN BELT DRIVE PARTS LIST

REF#	PART#	DESCRIPTION	QUANTITY
1	48-038	Spring Bracket	1
2	HMB-100-10	Machine Bushing, 1 x 10GA	2
3	21-445	Spring	1
	9020-8.5	Heat Shrink Tubing	1
4	76-412	Electric Clutch (Gas)	1
	76-337	Electric Clutch (Diesel)	1
	17-271	Pigtail (Diesel)	1
5	16-013	Idler Pulley	2
6	76-217	Idler Arm	1
7	76-298	Spacer	2
8	HB-12-13-400	Hex Bolt, $\frac{1}{2}$ - 13 x 3	2
	HW-12	Flat Washer, $\frac{1}{2}$	2
	HNTL-12-13	Nylon Lock Nut, $\frac{1}{2}$ - 13	2
9	HMB-12-14	Machine Bushing, $\frac{1}{2}$ x 14GA	5
	HP-18-150	Cotter Pin, $\frac{1}{8}$ x $1\frac{1}{2}$	1
10	76-102	Pulley, 2AK104H	1
	76-102-01	Hub, $1\frac{1}{4}$ ID	1
	HKSQ-14-150	Machine Key, $\frac{1}{4}$ x $\frac{1}{4}$ x $1\frac{1}{2}$	1
	76-200	Belt, 2/A74	1
11	HB-38-16-175	Hex Bolt, $\frac{3}{8}$ - 16 x $1\frac{3}{4}$	1
	HWL-38	Lock Washer, $\frac{3}{8}$	1
12	76-340	Clutch Strap	2
13	HB-516-18-100	Hex Bolt, $\frac{5}{16}$ - 18 x 1	3
	HW-516	Washer, $\frac{5}{16}$	3
	HNTL-516-18	Nylon Lock Nut, $\frac{5}{16}$ - 18	3
14	76-409	Belt Guard Support (Gas)	1
	76-339	Belt Guard Support (Diesel)	1
15	HB-38-16-300	Hex Bolt, $\frac{3}{8}$ - 16 x 3	2
	HNTL-38-16	Nylon Lock Nut, $\frac{3}{8}$ - 16	2
16	76-408	Clutch Mount (Gas)	1
	76-338	Clutch Mount (Diesel)	1
17	76-411	Stub Shaft (Gas)	1
	77-242	Stub Shaft (Diesel)	1

# FINGER/BRUSH REEL DRAWING

 **WARNING**

Do not lift reel head while engaged. Turn off reel before lifting or lowering.

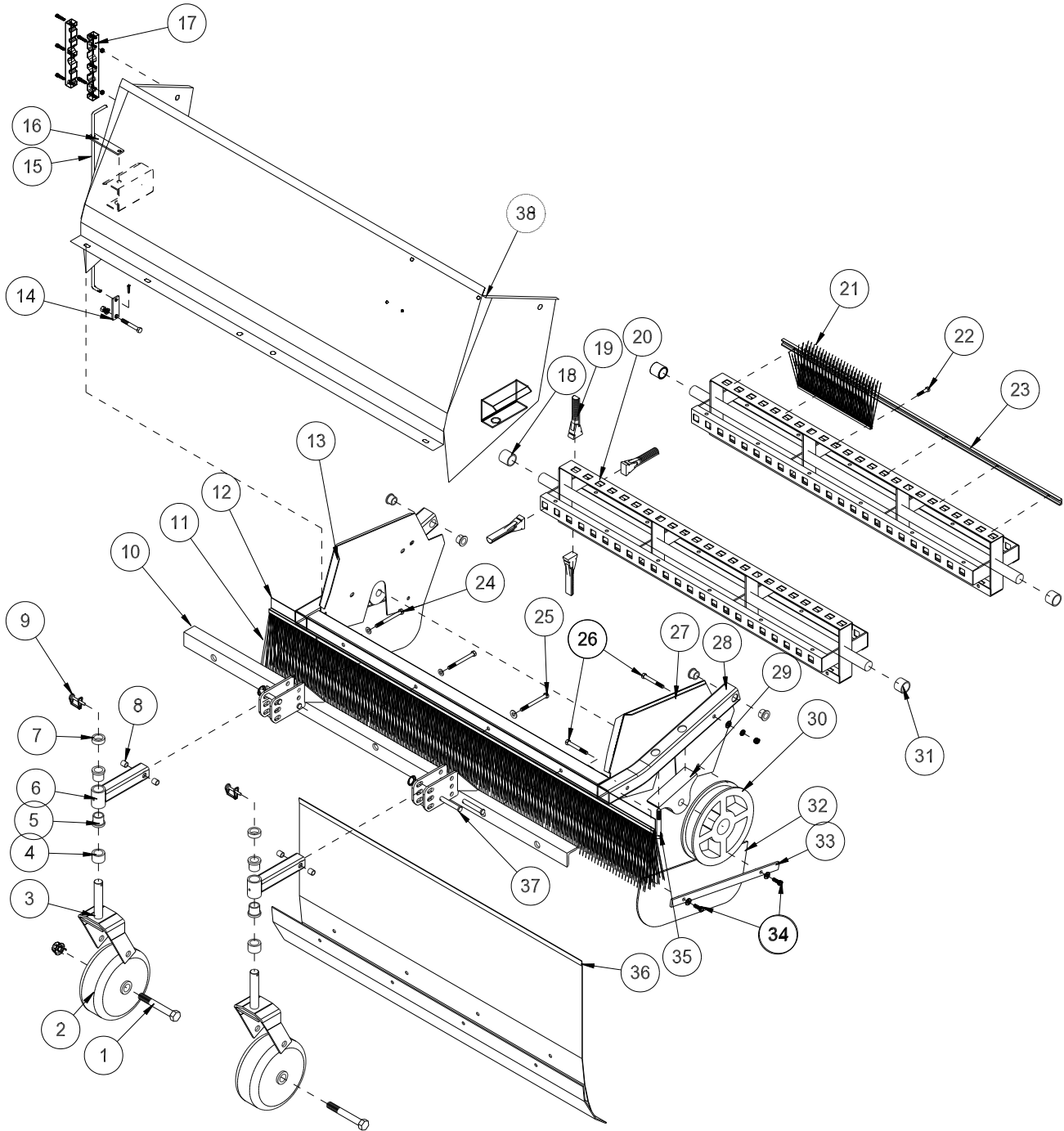

Parts



# FINGER /BRUSH REEL PARTS LIST

REF#	PART#	DESCRIPTION	QUANTITY
1	HB-34-10-550	Hex Bolt, $\frac{3}{4}$ - 10 x $5\frac{1}{2}$	2
	HNTL-34-10	Nylon Lock Nut, $\frac{3}{4}$ - 10	2
2	33-435	Tire and Wheel	2
	33-435-02	Wheel with Roller Bearing	
	33-435-03	Roller Bearing	
	33-435-04	Bushing	
3	48-046	Castor Fork	2
	HMB-100-10	Machine Bushing, 1 x 10GA	4
4	29-585	Spacer Height Adjustment	2
5	18-223	Bushing (part of 76-355)	2 per
6	76-355	Arm	2
7	29-584	Height Adjustment Spacer, $\frac{1}{2}$ "	2
8	20-019	Bushing (part of 76-355)	2 per
9	29-541	Lock Pin $\frac{1}{4}$	2
10	76-356	Castor Mount Bracket	1
	HCP-12-250	Clevis Pin $\frac{1}{2}$ x $2\frac{1}{2}$	4
	78-463	Kick-out Ring	4
11	76-439	Brush	1
12	76-438	Brush Channel	1
13	75-799	Side Plate RH.	1
14	76-278	Bottom Mount	1
	HB-38-16-300	Hex Bolt, $\frac{3}{8}$ - 16 x 3	1
	HNTL-38-16	Nylon Lock Nut, $\frac{3}{8}$ -16	1
15	76-277	Height Indicator Rod	1
16	76-279	Top Mount	1
17	76-336	Hose Clamp	1
18	75-686	Spacer, $1\frac{1}{4}$ ID x $1\frac{3}{8}$	1
19	75-506	Sweeper Finger	116
20	75-780	Finger Reel	1
21	76-330	Brush	4
22	HB-516-18-125	Hex Bolt, $\frac{5}{16}$ - 18 x $1\frac{1}{4}$	28
	HNTL-516-18	Nylon Lock Nut, $\frac{5}{16}$ - 18	28
23	76-313	Clamp	4
24	HB-38-16-350	Hex Bolt, $\frac{3}{8}$ - 16 x $3\frac{1}{2}$	2
	HW-38	Flat Washer, $\frac{3}{8}$	4
	HNTL-38-16	Nylon Lock Nut, $\frac{3}{8}$ - 16	2
25	HB-38-16-400	Hex Bolt, $\frac{3}{8}$ - 16 x 4	1
	HW-38	Flat Washer, $\frac{3}{8}$	2
	HNTL-38-16	Nylon Lock Nut, $\frac{3}{8}$ - 16	1
26	HB-38-16-350	Hex Bolt, $\frac{3}{8}$ - 16 x $3\frac{1}{2}$	1
	HB-38-16-275	Hex Bolt, $\frac{3}{8}$ - 16 x $2\frac{3}{4}$	7
	HNTL-38-16	Nylon Lock Nut $\frac{3}{8}$ - 16	4
27	75-800	Left Side Plate	1
28	75-787	Reel Frame	1
	18-221	Flange Bushing(part of 75-787)	4
29	75-511	Pillow Block, $1\frac{1}{4}$ Bore	2
30	76-102	Pulley with Hub	1
	76-102-01	Hub, $1\frac{1}{4}$ ID	1
	HMB-114-10	Machine Bushing, $1\frac{1}{4}$ x 14 GA	1 As Req'd
31	75-834	Spacer, $1\frac{1}{4}$ ID x $1\frac{1}{8}$	1
32	76-210	Matting, $7\frac{1}{2}$ x 18	2
33	76-213	Reel Guard Strap	2
34	HB-516-18-100	Hex Bolt, $\frac{5}{16}$ - 18 x 1	4
	HNTL-516-18	Nylon Lock Nut, $\frac{5}{16}$ - 18	4
35	HB-12-13-350	Hex Bolt, $\frac{1}{2}$ - 13 x $3\frac{1}{2}$	4
	HMB-12-14	Machine Bushing, $\frac{1}{2}$ - 14	4
	HNTL-12-13	Nylon Lock Nut, $\frac{1}{2}$ - 13	4
36	75-808	Front Baffle	1
37	HCP-12-250	Clevis Pin, $\frac{1}{2}$ x $2\frac{1}{2}$	4
	76-483	Knockout Ring	4
38	76-235	Grass Chute Frame	1
	8947-60	Trim Seal	2
	8842-14	Foam Tape	2

# REAR AXLE DRAWING

Parts

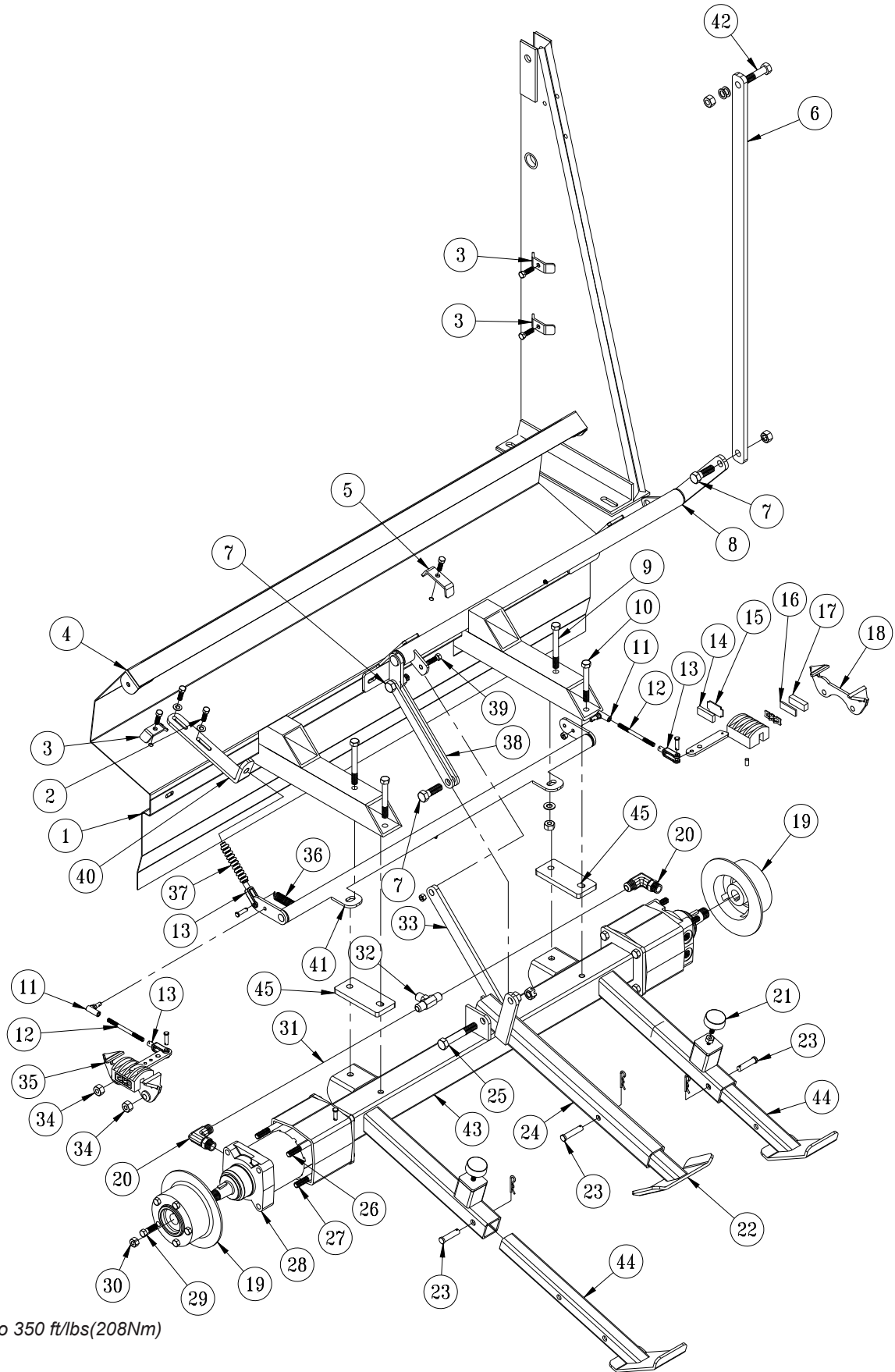

Torque to 350 ft/lbs(208Nm)

## REAR AXLE PARTS LIST

REF#	PART#	DESCRIPTION	QUANTITY
1	76-233	Rear Beater Panel	1
2	HB-38-16-125	Hex Bolt, $\frac{3}{8}$ - 16 x $1\frac{1}{4}$	2
	HW-38	Flat Washer, $\frac{3}{8}$	4
	HNTL-38-16	Nylon Lock Nut, $\frac{3}{8}$ - 16	2
3	13-099	Hose Clamp	3
	HB-516-18-125	Hex Bolt, $\frac{5}{16}$ - 18 x $1\frac{1}{4}$	2
	HWL-516	Lock Washer, $\frac{5}{16}$	2
	HB-516-18-150	Hex Bolt, $\frac{5}{16}$ - 18 x $1\frac{1}{2}$	1
	HNTL-516-18	Nylon Lock Nut, $\frac{5}{16}$ - 18	1
4	76-234	Rear Chute Baffle	1
	8947-60	Trim Seal, x 60"	1
5	75-614	Hose Clamp	1
	HB-516-18-150	Hex Bolt, $\frac{5}{16}$ - 18 x $1\frac{1}{2}$	1
	HNTL-516-18	Nylon Lock Nut, $\frac{5}{16}$ - 18	1
6	76-386	Long Linkage Strap	1
7	HB-58-11-200	Hex Bolt, $\frac{5}{8}$ - 11 x 2	3
	HNTL-58-11	Nylon Lock Nut, $\frac{5}{8}$ - 11	3
8	76-387	Rear Skid Pivot	1
9	HB-12-13-450	Hex Bolt, $\frac{1}{2}$ - 13 x 4 $\frac{1}{2}$	2
	HNTL-12-13	Nylon Lock Nut, $\frac{1}{2}$ - 13	2
10	HB-12-13-450	Hex Bolt, $\frac{1}{2}$ - 13 x 4 $\frac{1}{2}$	2
11	21-462	Ball Joint, $\frac{5}{16}$ - 24	2
12	76-300	Brake Rod	2
	HN-516-24	Hex Nut, $\frac{5}{16}$ - 24	4
13	11-100	Linkage Yoke, $\frac{5}{16}$	3
	HCP-516-100	Clevis Pin, $\frac{5}{16}$ x 1	3
	HP-18-075	Cotter Pin, $\frac{1}{8}$ x $\frac{3}{4}$	3
14*		Carrier Side Pad	1
15*		Carrier Side Pad Support	1
16*		Cam Side Pad Support	1
17*		Cam Side Pad	1
18	76-241	Right Caliper Clockwise	1
	HN-516-24	Hex Nut, $\frac{5}{16}$ - 24	1
19	76-239	Brake Disk, 8" 5 Hole	2
20	34-122	Short 90° Elbow	4
21	50-081	Rubber Bumper	2
	HN-38-16	Hex Nut, $\frac{3}{8}$ - 16	2
22	48-039	Rear Skid	1
23	HCP-12-225	Clevis Pin, $\frac{1}{2}$ x $2\frac{1}{4}$	4
	HHP-18	Bridge Pin, $\frac{1}{8}$	4
24	48-040	Rear Skid Arm	1
25	HB-58-11-400	Hex Bolt, $\frac{5}{8}$ - 11 x 4	1
	HNTL-58-11	Nylon Lock Nut, $\frac{5}{8}$ - 11	1
26	HB-12-13-800	Hex Bolt, $\frac{1}{2}$ - 13 x 8	4
27	HB-12-13-750	Hex Bolt, $\frac{1}{2}$ - 13 x $7\frac{1}{2}$	4
	HMB-12-14	Machine Bushing, $\frac{1}{2}$ x 14GA	4
	HNFL-12-13	Flange Nylon Lock Nut, $\frac{1}{2}$ - 13	8
*	34-101-02	Pad Kit with 2 Pads and Steel Backing Plates	2 Kits Req'd per Axle
	34-101-01	Pads Only	

(Continued on Next Page)

# REAR AXLE DRAWING

PARTS

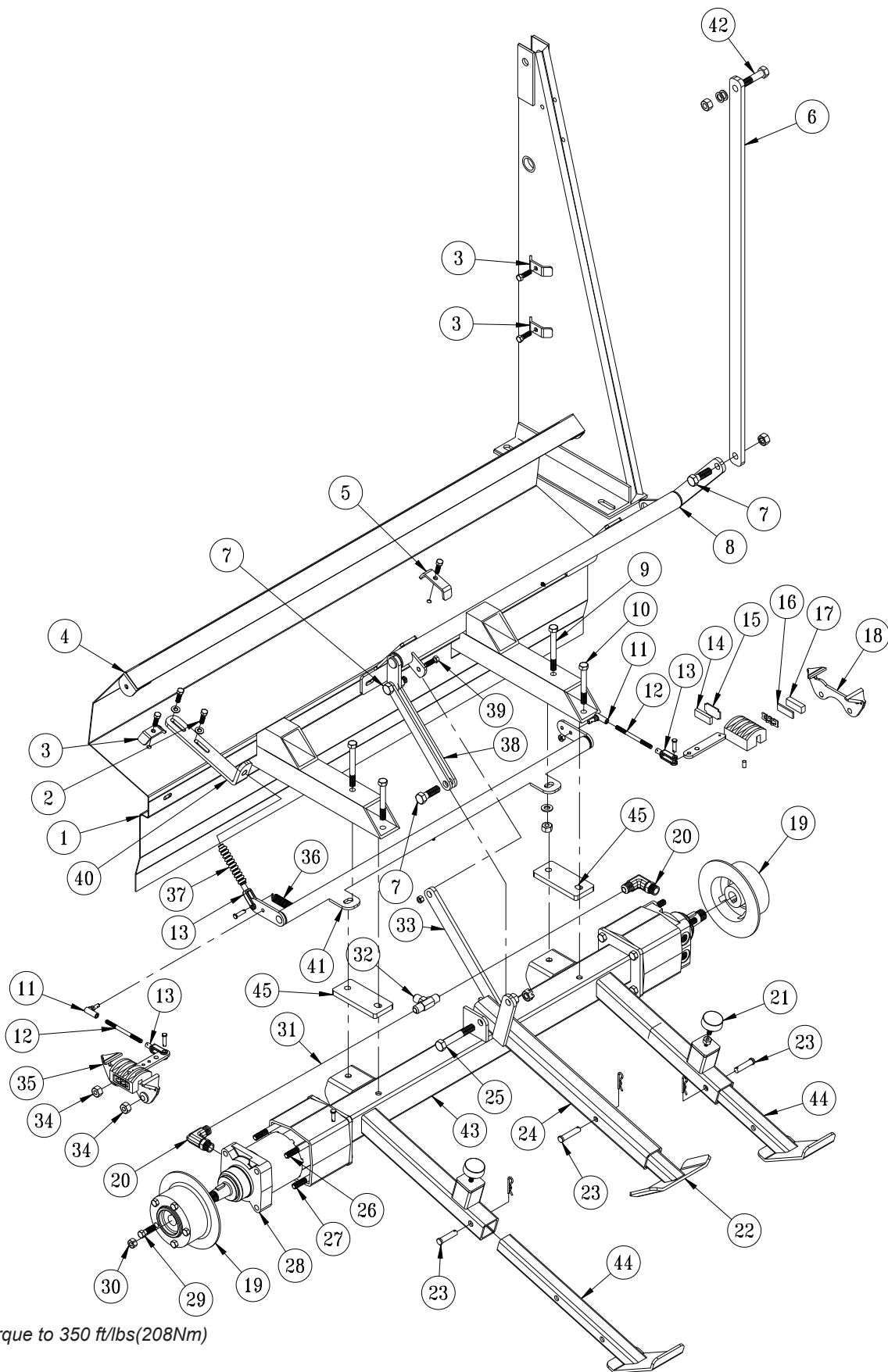

Torque to 350 ft/lbs(208Nm)

## REAR AXLE PARTS LIST

REF#	PART#	DESCRIPTION	QUANTITY
28	76-238	Wheel Motor	2
	HWK-516-100	Woodruff Key, $\frac{5}{16}$ x 1	2
29	60-268	Lug Nut, $\frac{1}{2}$ - 20 x $1\frac{5}{16}$	10
30	14-265	Nut, 1 - 20	2
31	76-208	Hydraulic Hose, 23.5"	4
32	34-057	Tee Fitting	2
33	76-385	Brace	2
34	HNTL-12-13	Nylon Lock Nut, $\frac{1}{2}$ - 13	4
35	76-240	Left Caliper Counterclockwise	1
36	29-118	Zinc Plated Spring	1
37	60-536	Bellows	2
	76-225	Brake Cable with Nuts	1
38	48-042	Linkage Strap Short	1
39	HB-38-16-125	Hex Bolt, $\frac{3}{8}$ - 16 x $1\frac{1}{4}$	1
	HNTL-38-16	Nylon Lock Nut, $\frac{3}{8}$ - 16	1
40	76-218	Brake Cable Bracket	1
41	76-229	Park Brake Relay	1
42	HB-58-18-325	Hex Bolt, $\frac{5}{8}$ - 18 x $3\frac{1}{4}$	1
	HMB-58-14	Machine Bushing, $\frac{5}{8}$ x 14GA	2
	HNCL-58-18	Center Nut, $\frac{5}{8}$ - 18	1
43	76-226	Rear Axle	1
44	75-723	Rear Skid	2
45	76-639	Axle Shim	2
*	34-101-02	Pad Kit with 2 Pads and Steel Backing Plates	2 Kits Req'd per Axle
	34-101-01	Pads Only	

# HOPPER DRAWING

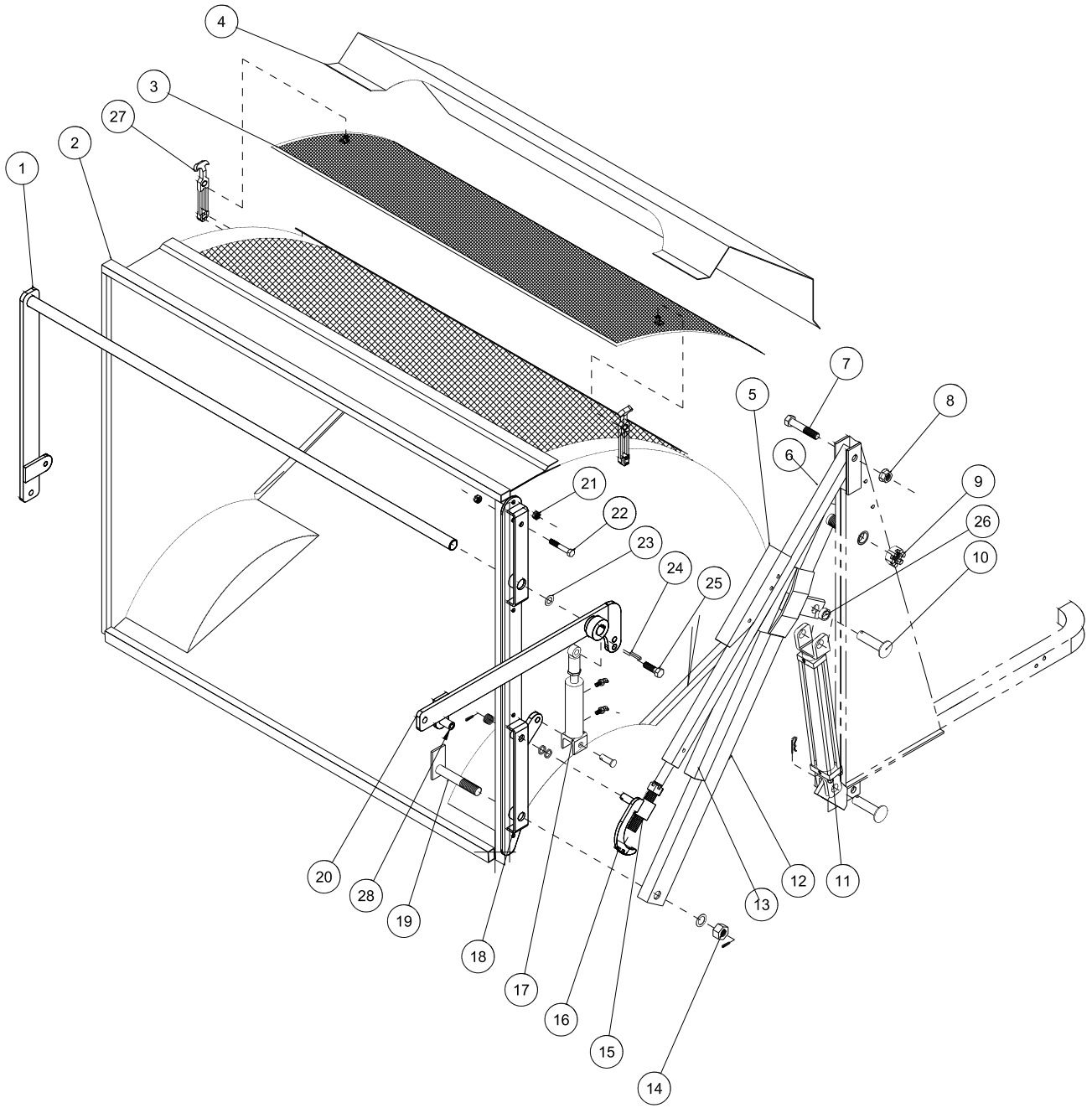

Parts

# HOPPER PARTS LIST

REF#	PART#	DESCRIPTION	QUANTITY
1	76-414	Left Tailgate Dump Bar	1
	HMB-114-10	Machine Bushing, 1 <sup>1</sup> / <sub>4</sub> x 10 GA	1
2	76-237	Hopper	1
3	76-261	Hopper Screen	1
4	76-359	Hopper Screen Cover	1
	HB-516-18-075	Hex Bolt, 5 <sup>5</sup> / <sub>16</sub> - 18 x 3 <sup>3</sup> / <sub>4</sub>	6
	HW-516	Flat Washer, 5 <sup>5</sup> / <sub>16</sub>	6
	HNTL-516-18	Nylon Lock Nut, 5 <sup>5</sup> / <sub>16</sub> - 18	6
5	75-653	Hopper Safety Lift	2
	HB-38-16-225	Hex Bolt, 3 <sup>3</sup> / <sub>8</sub> - 16 x 2 <sup>1</sup> / <sub>4</sub>	4
	HNW-38-16	Wing Nut, 3 <sup>3</sup> / <sub>8</sub> - 16	4
6	76-230	Hopper Dump Arm	2
	HNA-100-14	Slotted Hex Nut, 1 - 14	2
7	HB-34-10-400	Hex Bolt, 3 <sup>3</sup> / <sub>4</sub> - 10 x 4	2
	HMB-34-14	Machine Bushing, 3 <sup>3</sup> / <sub>4</sub> - 14GA	2
8	HNTL-34-10	Nylon Lock Nut, 3 <sup>3</sup> / <sub>4</sub> - 10	2
9	HNAT-114-12	Thick Axle Nut, 1 <sup>1</sup> / <sub>4</sub> - 12	2
	HP-316-100	Cotter Pin, 3 <sup>3</sup> / <sub>16</sub> x 1	2
10	HCP-100-325	Clevis Pin, 1 x 3 <sup>1</sup> / <sub>4</sub>	2
	HHP-.177	Bridge Pin	2
11	76-627	Hydraulic Cylinder	2
12	76-211	Arm Pivot Tube	1
	76-161	Hose Guard, Short	1
13	76-159	Hose Guard, Long	1
14	HMB-100-14	Machine Bushing, 1 x 14GA	2
	HNA-100-14	Slotted Hex Nut, 1 - 14	2
	HP-18-150	Cotter Pin, 1 <sup>1</sup> / <sub>8</sub> x 1 <sup>1</sup> / <sub>2</sub>	2
15	48-148	Right Adjustment Sleeve (shown)	1
	48-153	Left Adjustment Sleeve	1
	HMB-34-14	Machine Bushing, 3 <sup>3</sup> / <sub>4</sub> x 14GA	2
	HMB-34-10	Machine Bushing, 3 <sup>3</sup> / <sub>4</sub> x 10GA	8
	HP-18-150	Cotter Pin, 1 <sup>1</sup> / <sub>8</sub> x 1 <sup>1</sup> / <sub>2</sub>	2
16	75-704	Castle Nut, 1 - 14	2
17	77-263	Hydraulic Cylinder, 1 <sup>1</sup> / <sub>2</sub> x 7	1
	18-168	Elbow	2
	18-154	Rod End	1
	HG-14-28-180	Grease Fitting, 1 <sup>1</sup> / <sub>4</sub> - 28 x 180° (part of rod end)	1
	HCP-58-150	Clevis Pin, 5 <sup>5</sup> / <sub>8</sub> x 1 <sup>1</sup> / <sub>2</sub>	1
	HHP-18	Bridge Pin, 1 <sup>1</sup> / <sub>8</sub>	1
18	76-215	Right Hinge Strap (Shown)	1
	76-216	Left Hinge Strap	1
19	75-569	Swivel Pin	2
20	76-413	Right Tailgate Dump Bar	1
21	HNCL-38-16	Center Nylon Lock Nut, 3 <sup>3</sup> / <sub>8</sub> - 16	8
	HB-38-16-075	Hex Bolt, 3 <sup>3</sup> / <sub>8</sub> - 16 x 3 <sup>3</sup> / <sub>4</sub>	8
22	HB-12-13-300	Hex Bolt, 1 <sup>1</sup> / <sub>2</sub> - 13 x 3	2
	HN-12-13	Nut 1 <sup>1</sup> / <sub>2</sub> - 13	2
	HNCL-12-13	Center Nylon Lock Nut 1 <sup>1</sup> / <sub>2</sub> - 13	2

(Continued on next page)

# HOPPER DRAWING

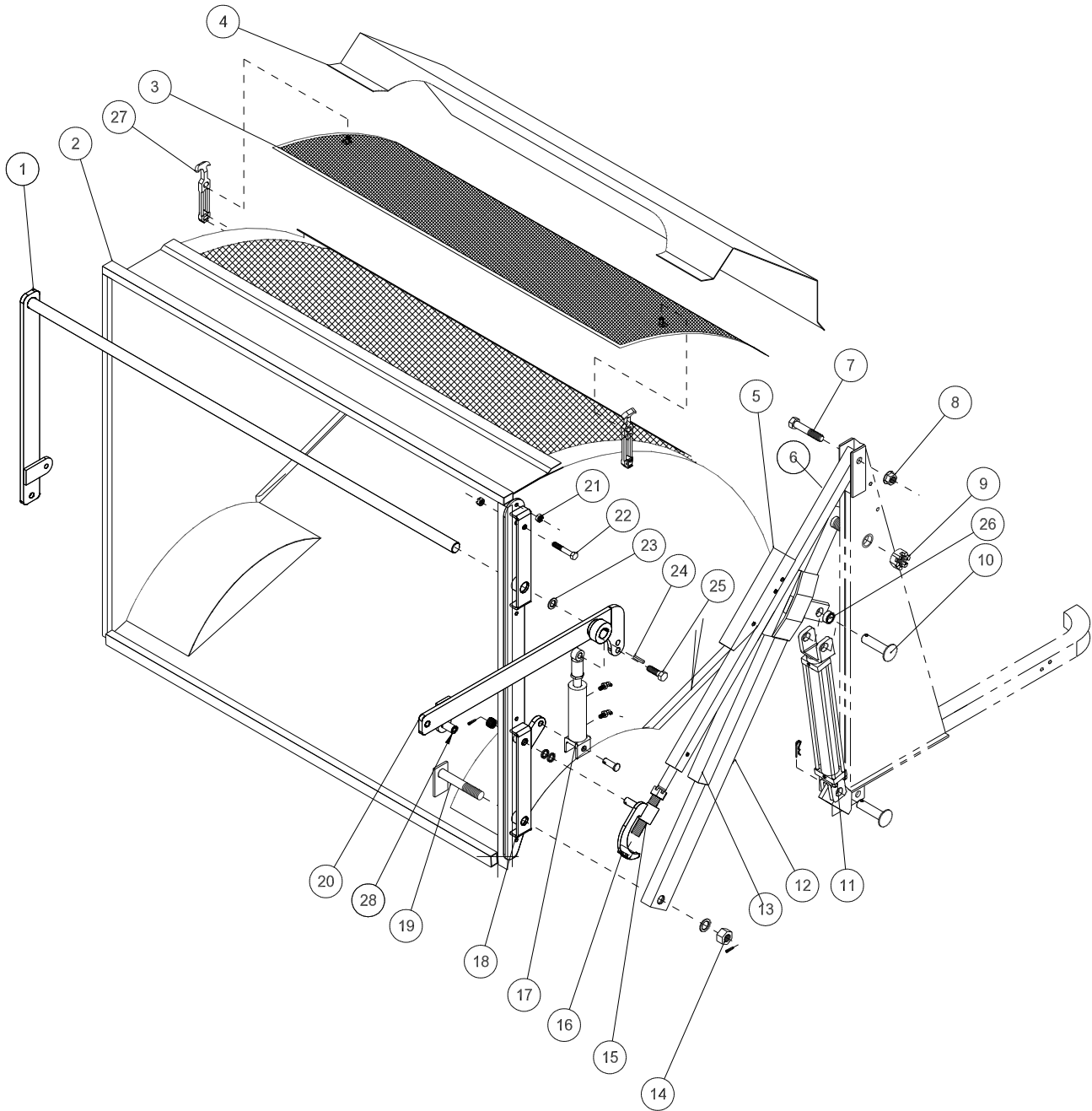

Parts



## HOPPER PARTS LIST

REF#	PART#	DESCRIPTION	QUANTITY
23	HMB-114-10	Machine Bushing, 1 <sup>1</sup> / <sub>4</sub> x 10GA	2 As Req'd
24	HKSQ-14-150	Machine Key, 1 <sup>1</sup> / <sub>4</sub> x 1 <sup>1</sup> / <sub>4</sub> x 1 <sup>1</sup> / <sub>2</sub>	1
	HSSHS-516-18-038	Set Screw, 5 <sup>1</sup> / <sub>16</sub> - 18 x 3 <sup>3</sup> / <sub>8</sub>	1
	HRP-38-250	Roll Pin, 3 <sup>3</sup> / <sub>8</sub> x 2 <sup>1</sup> / <sub>2</sub>	1
25	HB-58-11-200	Hex Bolt, 5 <sup>5</sup> / <sub>8</sub> - 11 x 2	1
	HMB-58-14	Machine Bushing, 5 <sup>5</sup> / <sub>8</sub> x 14GA	3
	HNCL-58-11	Center Nylon Lock Nut, 5 <sup>5</sup> / <sub>8</sub> - 11	1
*26	76-288	Spacer	2
27	15-437	Latch	2
	HRS-316-1125	Rivet, 3 <sup>3</sup> / <sub>16</sub> x 1 <sup>1</sup> / <sub>8</sub>	4
	HRW-316	Rivet Washer, 3 <sup>3</sup> / <sub>16</sub>	6
	HW-316	Flat Washer, 3 <sup>3</sup> / <sub>16</sub>	4
28	42-702	Spacer	2
	HB-12-13-250	Hex Bolt, 1 <sup>1</sup> / <sub>2</sub> - 13 x 2 <sup>1</sup> / <sub>2</sub>	2
	HNCL-12-13	Center Nylon Lock Nut, 1 <sup>1</sup> / <sub>2</sub> - 13	2

\*Spacer **MUST** be to the outside of the tab on the Pivot Arm with the tab and the spacer inside the cylinder yoke.

# TAILGATE DRAWING

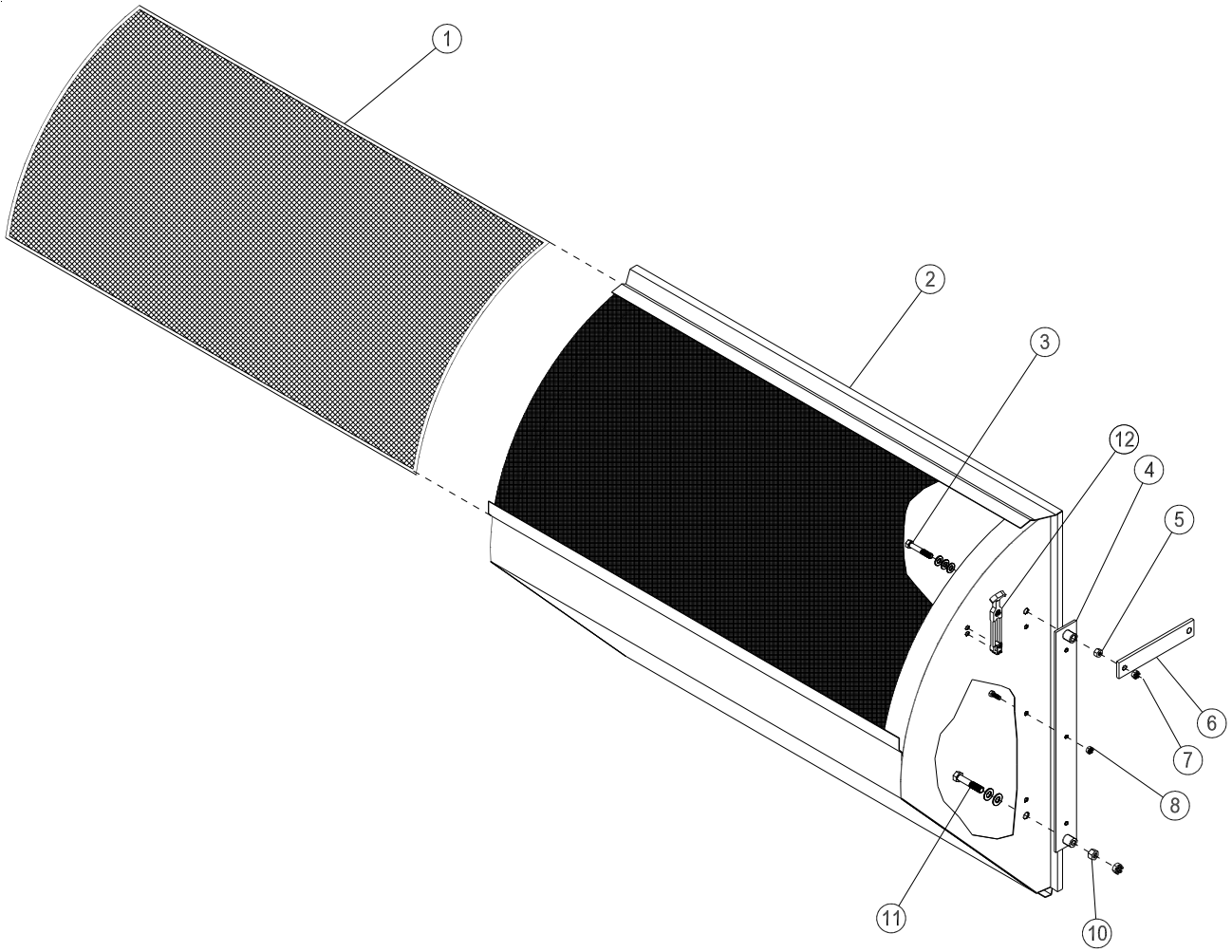

Parts

## TAILGATE PARTS LIST

REF#	PART#	DESCRIPTION	QUANTITY
1	76-262	Tailgate Screen	1
2	76-243	Tailgate	1
3	HB-12-13-300	Hex Bolt, 1/2 - 13 x 3	2
	HMB-12-14	Machine Bushing, 1/2 x 14GA	6
4	75-565	Tailgate Hinge Strap	2
5	HN-12-13	Hex Nut, 1/2 - 13	2
6	75-564	Tailgate Hinge	2
7	HNCL-12-13	Center Nylon Lock Nut, 1/2 - 13	2
8	HNTL-38-16	Nylon Lock Nut, 3/8 - 16	6
	HB-38-16-100	Hex Bolt, 3/8 - 16 x 1	6
10	HNJ-58-18	Jam Nut, 5/8 - 18	9
11	HB-58-18-325	Hex Bolt, 5/8 - 18 x 3 1/4	2
	HMB-58-14	Machine Bushing, 5/8 x 14GA	10
12	15-437	Latch	2
	HRS-316-1125	Rivet Steel, 3/16 x 1 1/8	4
	HRS-316-100	Rivet Steel, 3/16 x 1	2
	HRW-316	Rivet Washer, 3/16	4
	HW-316	Flat Washer, 3/16	2
NS	8828-60	Weather Stripping (60")	1

# 77-266 EATON HYDROSTATIC PUMP DRAWING (DIESEL)

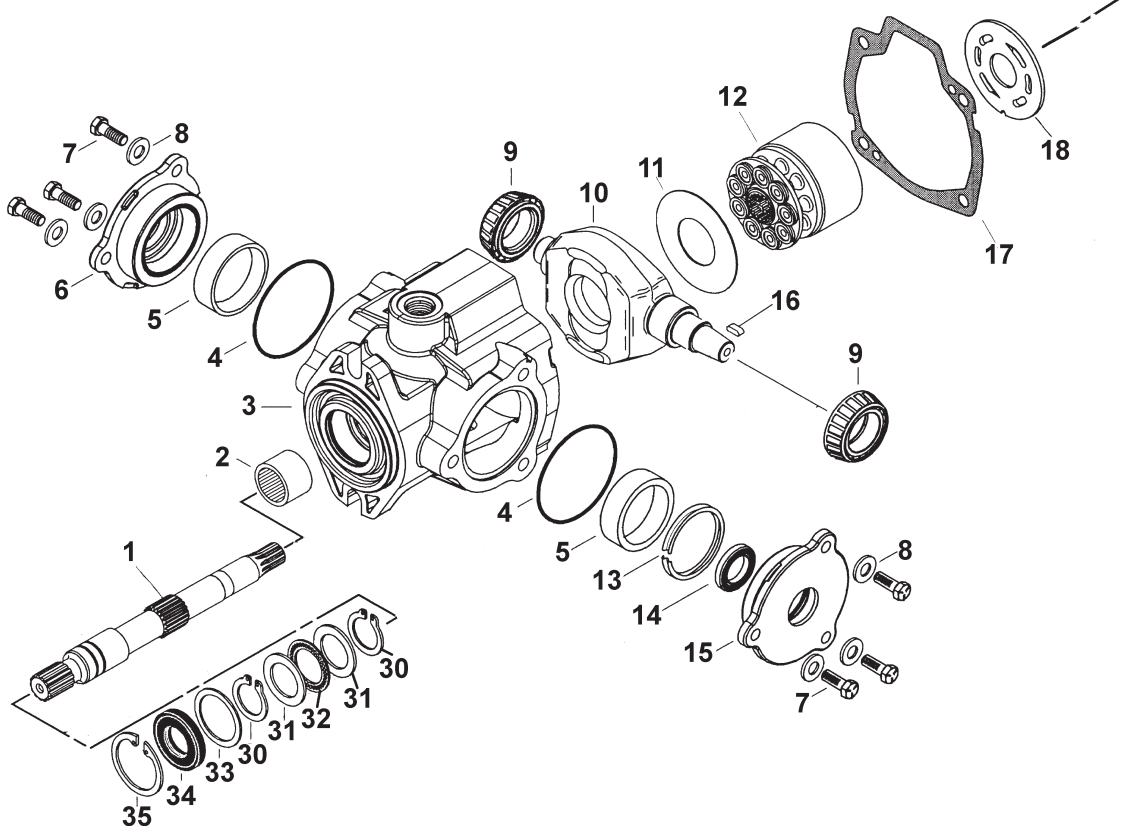
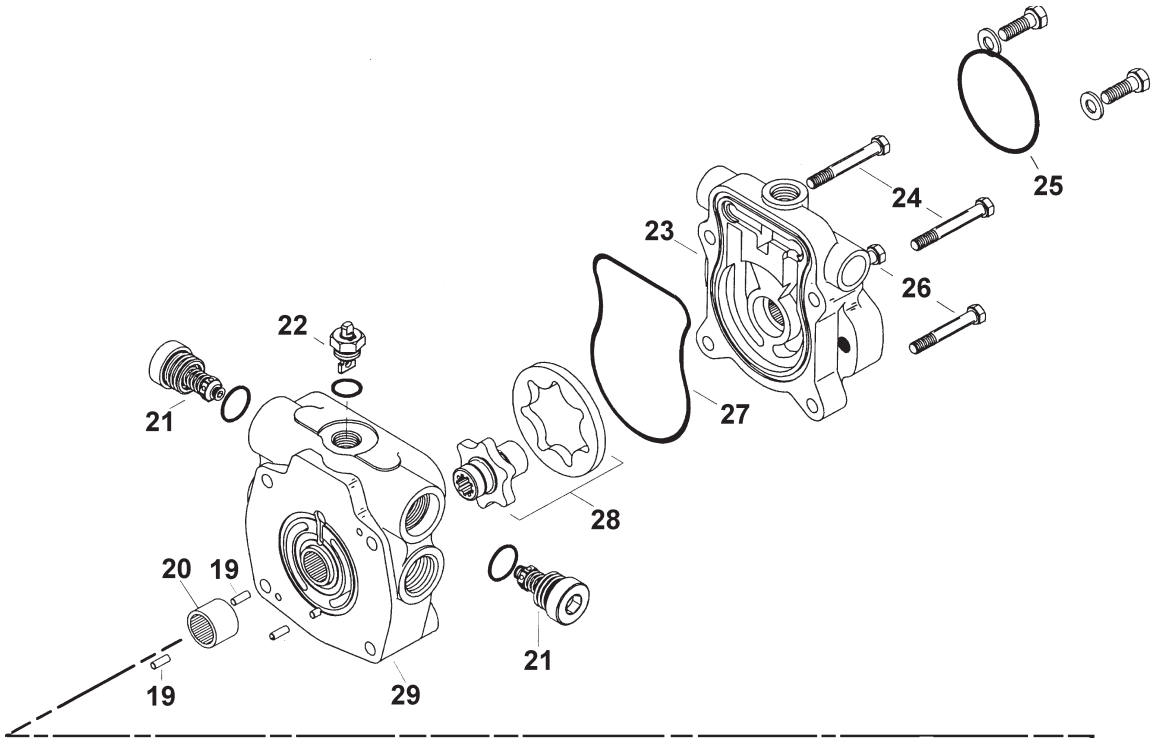

Parts

## 77-266 EATON HYDROSTATIC PUMP PARTS LIST (DIESEL)

REF#	PART#	DESCRIPTION	QUANTITY
1	60-343-52	Drive Shaft (splined)	1
2		Needle Bearing (with housing)	1
3	77-239-01	Housing	1
4	77-239-02	O-Ring	1
5	77-239-03	Thrust Bearing	2
6	77-239-04	Trunnion Cover	1
7	77-239-05	Pan Head Screw	2
8	77-239-06	Washer	6
9	77-239-07	Cone Bearing	2
10	77-239-08	Cam Plate	1
11	77-239-09	Swash Plate Insert	1
12	60-343-21	Rotating Kit	1
13	77-239-10	Crush Ring	1
14*	60-343-12	Shaft Seal	1
15	77-239-11	Seal Cover	1
16		Key	1
17*	77-239-13	Gasket	1
18	76-482-01	Valve Plate	1
19		Dowel Pin	2
20		Bearing	1
21	77-239-15	Relief Valve (4000 psi)	2
22	77-239-16	Tow Valve Assembly	1
23		Charge Pump Adapter	1
24	77-239-17	Cap Screw	2
25*	77-130	O-Ring (mounting kit)	1
26	77-239-18	Cap Screw	2
27*	60-343-44	O-Ring	1
28	60-343-43	Gerotor and Coupler	1
29	77-239-20	End cover Assembly	1
30*	77-239-21	Retaining Ring	2
31	60-343-05	Bearing Race	1
32	60-343-06	Thrust Bearing	1
33	60-343-03	Washer	2
34*	60-343-02	Shaft Seal	1
35*	60-343-01	Retaining Ring	1
* 	77-239-23	Seal Repair Kit	

# 76-638 EATON HYDROSTATIC PUMP DRAWING (GAS)

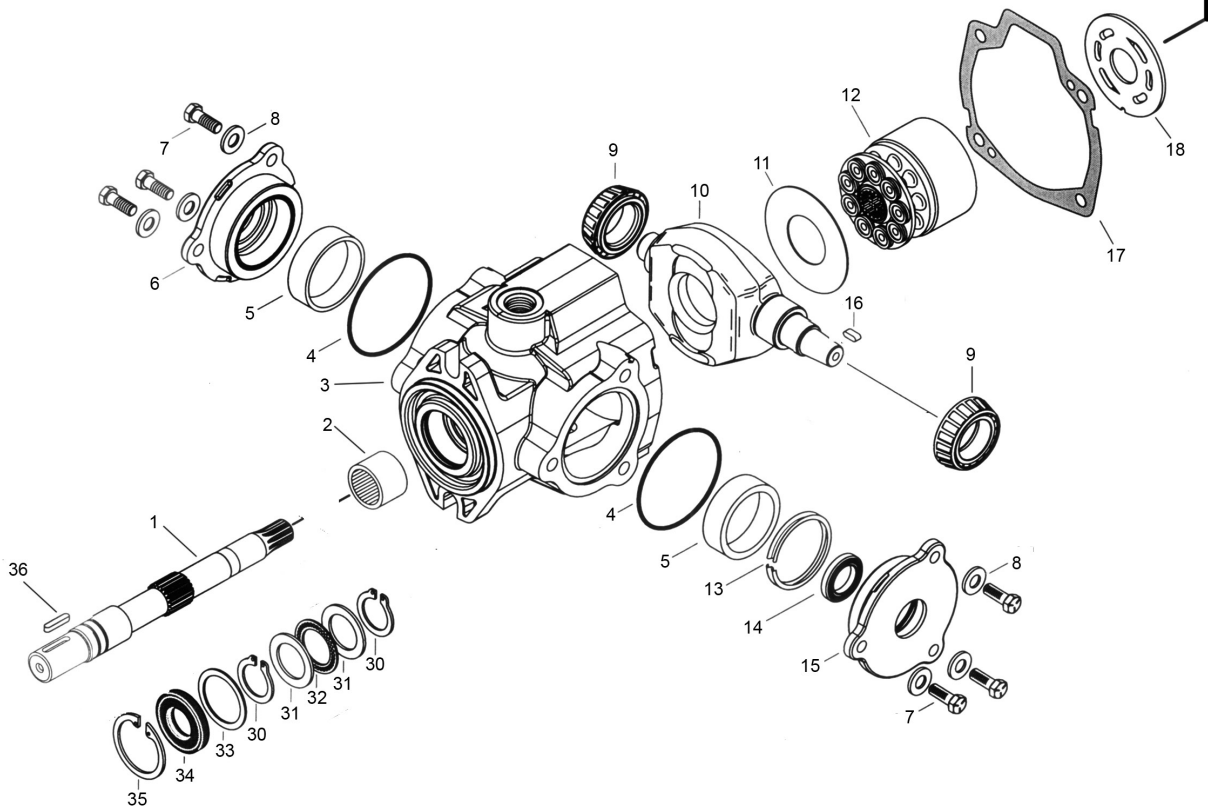
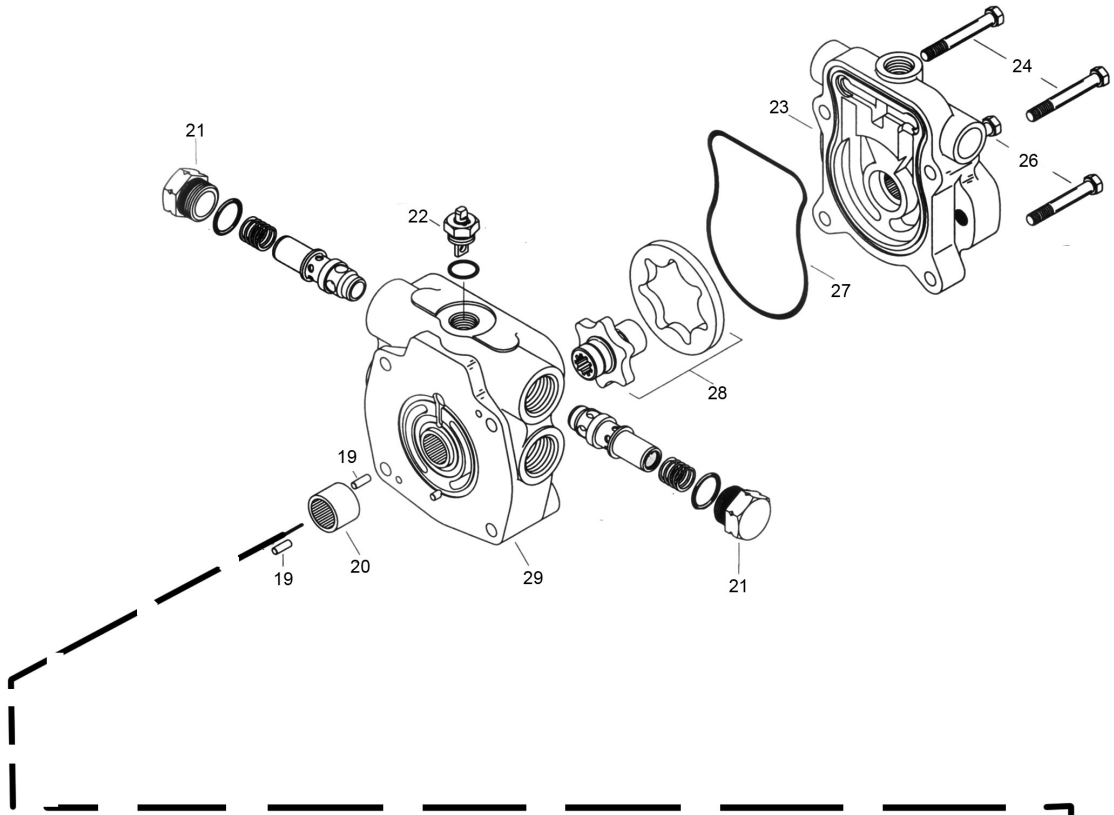

Parts

## 76-638 EATON HYDROSTATIC PUMP PARTS LIST (GAS)

REF#	PART#	DESCRIPTION	QUANTITY
1	76-398-01	Drive Shaft (splined)	1
2		Needle Bearing (with housing)	1
3	77-239-01	Housing	1
4	77-239-02	O-Ring	1
5	77-239-03	Thrust Bearing	2
6	77-239-04	Trunnion Cover	1
7	77-239-05	Pan Head Screw	2
8	77-239-06	Washer	6
9	77-239-07	Cone Bearing	2
10	77-239-08	Cam Plate	1
11	77-239-09	Swash Plate Insert	1
12	60-343-21	Rotating Kit	1
13	77-239-10	Crush Ring	1
14*	60-343-12	Shaft Seal	1
15	77-239-11	Seal Cover	1
16		Key	1
17*	77-239-13	Gasket	1
18	76-482-01	Back Plate	1
19		Dowel Pin	2
20		Bearing	1
21	77-239-15	Relief Valve	2
22	77-239-16	Tow Valve Assembly	1
23		Charge Pump Adapter	1
24	77-239-17	Cap Screw	2
26	77-239-18	Cap Screw	2
27*	77-239-19	O-Ring	1
28	60-343-43	Gerotor and Coupler	1
29		End Cover Assembly	1
30*	77-239-21	Retaining Ring	2
31	60-343-05	Bearing Race	1
32	60-343-06	Thrust Bearing	1
33	60-343-03	Washer	2
34*	60-343-02	Shaft Seal	1
35*	60-343-01	Retaining Ring	1
36	60-343-49	Key	1
* 	77-239-23	Seal Repair Kit	

# 76-638/77-266 REPAIR DISASSEMBLY INSTRUCTIONS

## Disassembly

The following disassembly procedure applies to a single pump with or without gear pump. The repair procedure for tandem pumps, once they are separated, is basically the same. The basic configuration differences between a single and tandem pumps are the backplates, pump shafts and housing assemblies. In most cases, only the rear pump of tandem units contain a charge pump, which is common to both the front and rear pump. The rear tandem pump does not incorporate a shaft seal.

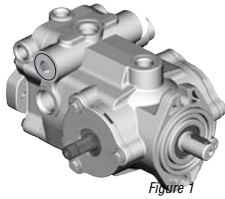

Figure 1

Thoroughly clean the Eaton Model 70160 or 78162 variable displacement pump before any repairs are attempted. When working on tandem pumps, separate the front and rear pumps first.

**1** Support the pump with the input shaft down. Use a 1/2 in. socket or end wrench to remove the pump adapter cover plate or gear pump (see Figure 2).



Figure 2

**2** Use a pick or similar tool to remove the adapter cover plate or gear pump o-ring. (See Figure 3)

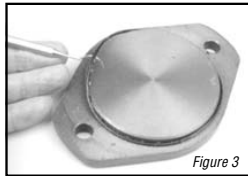

Figure 3

**3** Use a 7/16 in. Allen wrench or bit socket remover to remove the charge pressure relief valve spring retainer from the pump adaptor assembly (see Figure 4).



Figure 4

**4** Use a pencil magnet or similar tool to carefully remove the charge pressure spring and poppet from the pump adaptor assembly. (See Figure 5) Use caution not to drop the charge pump poppet into the pump adaptor assembly.

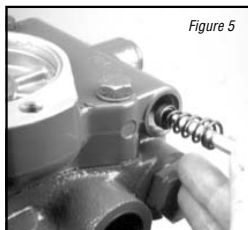

Figure 5

**5** The charge pressure relief valve and poppet may be of the standard or high pressure type. The (6.9 to 10.3 bar [100 to 150 PSI]) standard spring and poppet are shown on the bottom and the optional high pressure (13.7 to 20.7 bar [200 to 300 PSI]) spring and poppet is shown on the top.

The same charge pressure relief valve spring retainer is used with either the standard or high pressure (see Figure 6).

**6** Use a 7/8 in. socket or end wrench to remove the optional bypass valve assembly from the backplate (see Figure 7).



Figure 6

**7** The internal seal may be replaced by first removing the small retaining ring on the end of the bypass valve. Remove and replace the o-rings (see Figure 8).

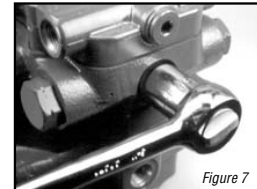

Figure 7

**8** Use a 9/16 in. hex key to remove the two high pressure relief valves from the pumps backplate assembly (see Figure 9). Remove relief valve as shown from each side (see Figure 10). Each system relief valve S/A is identified by both its part number and relief valve setting as shown in Parts Information manual.

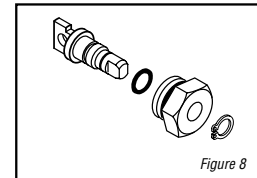

Figure 8

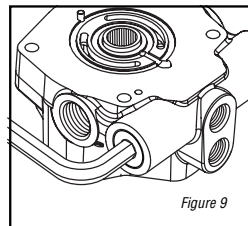

Figure 9

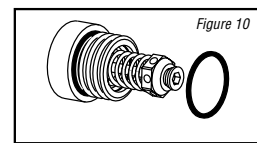

Figure 10

**9** Firmly support the pump assembly. Use a 1/2 in. socket or end wrench to remove the four cap screws retaining the charge pump adapter assembly.

**10** With the cap screws removed, remove the charge pump adaptor assembly from the backplate (see Figure 11).

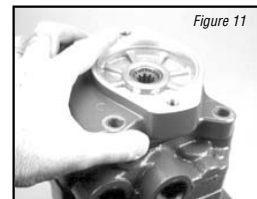

Figure 11

Note: The front pump assemblies do not have charge pump adapter assemblies.

**11** Turn the adapter assembly over. Use an o-ring pick or similar tool remove the o-ring seal (see Figure 12).

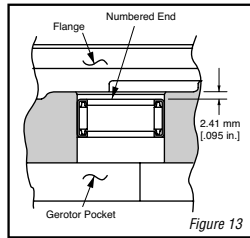

Figure 12

**12** Inspect the gerotor pocket and needle bearing located in the charge pump adapter. The needles in the needle bearing must remain intact in the bearing cage.



**13** When the needle bearing assembly is replaced, the numbered end of the bearing must face toward the flange side of the adapter to the dimension as shown (see Figure 13).



**14** With the charge pump adapter removed, remove the charge pump outer ring and inner gerotor ring assembly (see Figure 14 and 15).

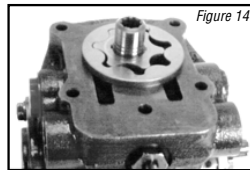

**15** Charge pumps are available in two different displacements. Charge pump displacements are based on the thickness of the gerotor assembly and the depth of the pocket located in the charge pump adapter. To determine the displacement, refer to the table below.

**Gerotor Pocket Depth**

Displacement cm <sup>3</sup> /r [in <sup>3</sup> /r]	Depth of Pocket mm [in.]
6.9 [.42]	6.35 [.25]
13.8 [.84]	12.7 [.50]

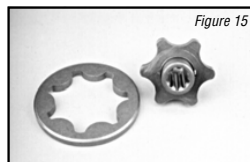

**16** To separate the backplate assembly from the dowel pins in the pump housing assembly, insert two screwdrivers between backplate and housing assembly and pry upward (see Figure 16).

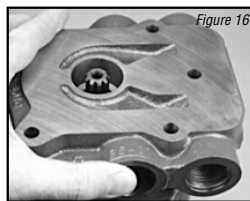

**17** After separation, remove the backplate from the housing assembly.

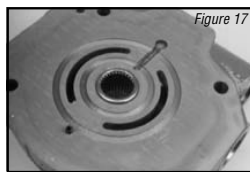

**18** Turn the backplate assembly over and inspect the needle bearing. The needles in the needle bearing must remain intact in the bearing cage (see Figure 17).

**19** When the needle bearing assembly is replaced, the numbered end of the bearing must face the valve plate side of the backplate to the dimension as shown (see Figure 18).

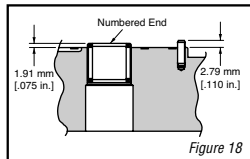

**20** With the backplate removed, remove the gasket from the pump housing assembly and discard (see Figure 19).



**21** Remove the valve plate from the piston block assembly. Note: This valve plate may have stuck to the backplate assembly that was previously removed.

**22** Valveplate directional rotation (CW or CCW) is identified by the location of the metering slots located on the face of the valve plates. Pump input rotation should always turn into the metering slots (see Figure 20). A clockwise valve plate is shown on the left and a counter clockwise valveplate is on the right.

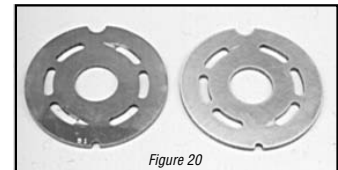

Note: Whenever pump input rotation is changed, the valve plate must be replaced along with the desired rotation charge pump adapter.

**23** Remove the rotating kit assembly by carefully retaining it in the housing assembly (see Figure 21). Lift the housing and rotating kit assembly and turn over assemblies allowing the rotating kit assembly to slide down the input shaft and out of the pump housing.

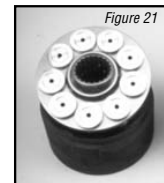

**24** With the rotating kit assembly removed, remove the piston assemblies, spider and spider pivot from the piston barrel. (see Figure 22).



**25** Inspect the piston assemblies, spider, spider pivot and piston block. The piston block assembly usually requires no further disassembly unless the pins or block spring are damaged.

**26** When any excessive wear or scratches are noted on the face of the piston block, the block assembly must be replaced (see Figure 23).



**DO NOT LAP THE FACE OF PISTON BLOCK ASSEMBLY.**

**27** To remove the input shaft assembly, use a pair of internal snap ring pliers and remove the shaft seal retaining ring from the housing assembly (see Figure 24).



# 76-638\77-266 REPAIR DISASSEMBLY INSTRUCTIONS

**28** With the retaining ring removed, use a small press to press the shaft seal and input shaft assembly from the housing assembly.

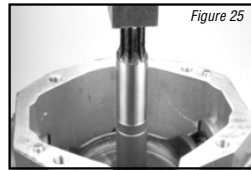

**29** With the input shaft assembly removed, disassemble the assembly for inspection by removing the shaft seal, washer, retaining ring thrust washers and bearing (see Figure 26).



Note: The rear pump on tandem units uses a spacer in place of shaft seals.

**30** To remove the camplate from the housing assembly, use a 9/16 in. socket or end wrench and remove the three cap screws and washers retaining the control arm cover plate assembly. Start at the cover plate with control arm (see Figure 27).

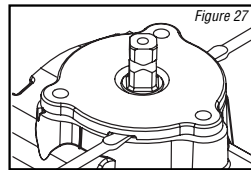

**31** With the retaining cap screws removed, insert two small screwdrivers in the notches located in the cover plate assembly and pry upward. Make sure bearing cup comes off with the cover plate (see Figure 28).

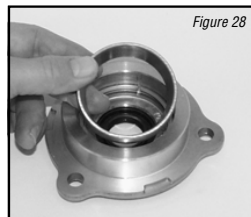

Note: The crush ring in the control arm trunnion cover does not need to be removed (see Figure 29). The only time the crush ring needs to be removed is when either the trunnion cover, the camplate assembly or the housing assembly is replaced. A shim kit is then required in the crush ring's place.

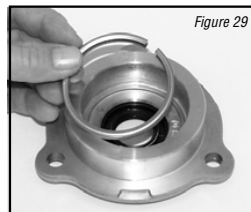

**32** Reposition the pump assembly to remove opposite cover plate. The bearing cup in this cover plate is press fit and not removable. Repeat steps 30 through 31.

**32b** Remove the slip fit bearing on the non-control arm side of the camplate.

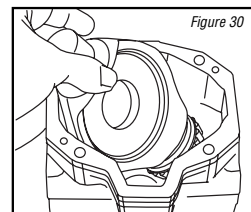

**33** With housing in the upright position, slide the camplate toward the control side and lift it from the pump housing (see Figure 30).

Note: The camplate control shaft will fit out either side of the pump housing. Be sure to note on which side of the housing the control shaft protrudes before removing camplate from

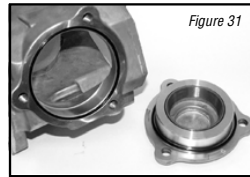

**34** Use an o-ring pick or similar tool to remove the o-ring seals from the two counter-bores in the housing or the cover plates (see Figure 31).

**35** To remove the control side cover plate lip seal, use a small press and press the lip seal inward (see Figure 32).

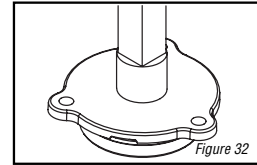

**36** Remove the thrust plate from the camplate. The thrust plate is reversible and either side may face the camplate (see Figure 33).



**37** Inspect the housing assembly's front needle bearing. If the needles remain in their cage and move freely, replacement usually is not required (see Figure 34).

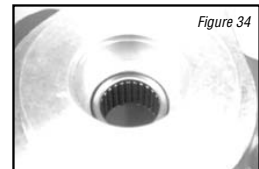

**38** When the needle bearing is replaced, the numbered end of the needle bearing must face away from the housing and pressed to the dimension as shown (see Figure 35).

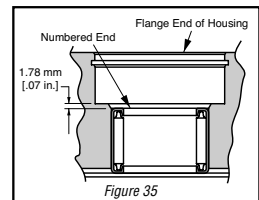

## Reassembly

**1** Before reassembling the pump, replace all worn and damaged parts, assemblies, seals and o-rings. Lubricate the seals and o-rings with petroleum jelly to help retain them during reassembly and to provide lubrication to the input and control shaft seals. Lubricate all finished part surfaces freely with clean hydraulic fluid to help provide start up lubrication between all rotating parts.

**2** To reassemble the camplate assembly into the pump housing, tilt the camplate slightly and install the control side of the camplate through the previously noted or marked side of the housing assembly (see Figure 36).

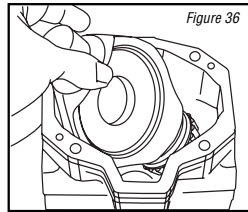

**3** Lubricate the tapered bearing and reassemble it on the non-control arm side of the camplate (see Figure 37).

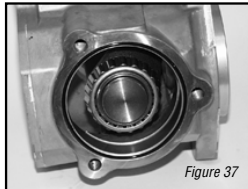

**4** Lubricate and install the o-ring seal into counter-bore of housing (see Figure 37).

**5** Install the trunnion cover over bearing and onto pump housing. Install the three cap screws and washers, torque screws to 39,3 Nm [29 ft-lb] (see Figure 38).

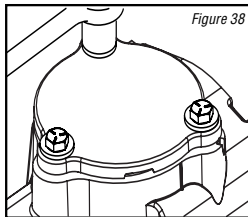

**6** Lubricate and install the control arm shaft seal into the control arm cover plate. Install with the lip of the seal facing upward or to the inside of the pump (see Figure 39).

**7** If the housing, trunnion covers or camplate assembly have not been replaced, the existing crush ring may be re-used. If you have replaced anyone of the above a shim kit must replace the crush ring. See Parts Information manual for number.

**8** Place the bearing cup into trunnion cover over the crush ring or shims (see Figure 40).

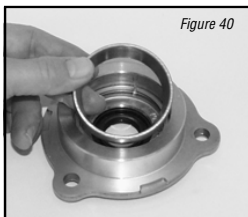
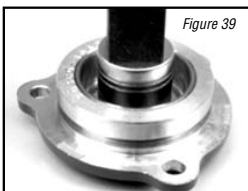

**9** Lubricate and install the o-ring seal into counter-bore of housing (see Figure 41).

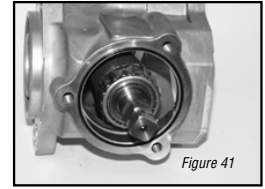

**10** Install the trunnion cover over the control shaft and into the pump housing. Install the three retaining cap screws and washers, torque screws to 39,3 Nm [29 ft-lb] (see Figure 42).

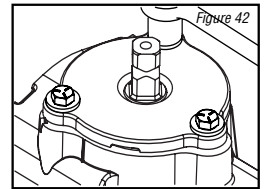

**11** Using your fingers, tilt the camplate back and forth to check the trunnion bearing preload. Proper preload is achieved when the camplate has a very slight tilting resistance. The camplate must not have any or very little side clearance.

**12** Reassemble the input shaft assembly by installing the thrust washer, thrust bearing, second thrust washer, retaining ring, washer and shaft seal (see Figure 43).



Note: The lip of the shaft seal must point toward the center of the input shaft.

**13** Install the input shaft assembly into the housing assembly. Push the shaft seal in just far enough so you can start the shaft seal retaining ring.

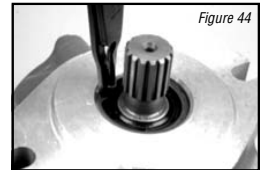

**14** Use a pair of snap ring pliers to install retaining snap ring into the housing assembly (see Figure 44).

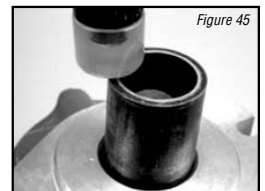

**15** Use a seal driver or similar tool to press or drive the snap ring and seal into the housing assembly (see Figure 45).

**CAUTION!** Press or drive inward until the snap ring snaps into the snap ring groove located in the pump housing assembly.

**16** The thrust plate is reversible. Either side will fit into the camplate. In most cases if any irregularities are noted it is best to replace the thrust plate (see Figure 46).

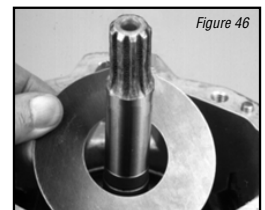

# 76-638/77-266 REPAIR REASSEMBLY INSTRUCTIONS

**18** Lubricate and install the thrustplate over the input shaft assembly and into the camplate. The thrustplate must rest firmly in its pocket located in the camplate.

**19** Reassemble the rotating kit assembly by first aligning the splines in the pivot with the splines in the block. Install the pivot on the block assembly pins (see Figure 47).

**20** Use a small socket or similar tool to help retain the pivot in the centered position. Lubricate and install the spider and piston assemblies onto the pivot and pistons into the piston block assembly (see Figure 48).

**21** Hold the housing assembly in the vertical position then carefully install the rotating kit by first aligning with the splines on the input shaft. With splines aligned, install the rotating kit into the pump housing (see Figure 50). Use caution to ensure all parts are kept in their proper position.

**22** With the rotating kit installed, reposition the housing assembly in the input shaft down position and install a new housing gasket (see Figure 50).

**23** Lightly coat the backplate side of the valve plate with petroleum jelly for retention during assembly. Install the valve plate over the needle bearing, aligning the small slot on the outside of the valve plate with the dowel pin in the backplate (see Figure 51).

**24** Carefully install the backplate assembly by aligning it with the dowel pins located in the pump housing. Use caution not to dislodge the valve plate (see Figure 54).

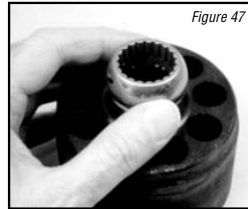

Figure 47



Figure 48

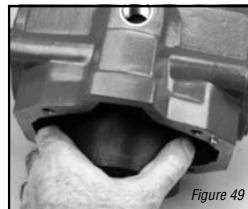

Figure 49

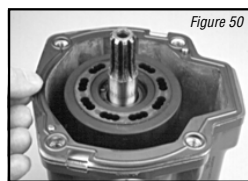

Figure 50

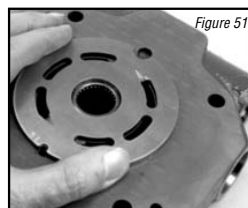

Figure 51

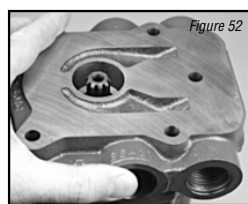

Figure 52

**25** Align the spline of the gerotor's inner ring, then lubricate and install the inner ring and outer ring over the input shaft and onto the backplate assembly (see Figure 53).

Note: Before installing the charge pump adaptor plate, offset the outer ring of the gerotor as shown.

**26** With the gerotor assembly installed, install new o-ring into charge pump adaptor plate and place adapter onto backplate over gerotor. Retain with cap screws. Torque cap screws to 25 N•m [18.5 lbf•ft] (see Figure 54).

**27** Install the two high pressure relief valves. Torque valves 128,8 to 142,4 Nm [95 to 105 lb-ft] (see Figure 55).

**29** Lubricate and reassemble the bypass valve assembly. Install the bypass valve into the backplate. Torque valve to 30,5±2 Nm [22.5±1.5 lb-ft] (see Figure 56).

**30** Coat the charge pressure poppet with petroleum jelly and place poppet onto spring and install into the adapter plate (see Figure 57).

**31** Install the hollow charge pressure relief valve retainer into the adapter plate. Torque retainer to 6,8 to 9,5 Nm [5 to 7 lb-ft].

**32** Lubricate and install the o-ring on the cover plate or gear pump. Install the cover plate or gear pump and two cap screws. Torque cap screws to 36,6 to 40 Nm [27 to 31 lb-ft].

The Model 70160 or 78162 variable displacement pump is now ready for test and reinstallation.

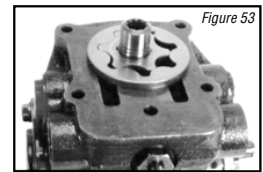

Figure 53

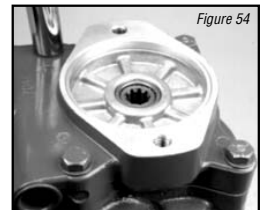

Figure 54

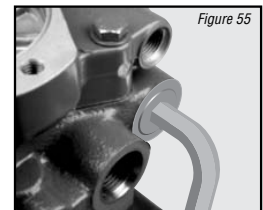

Figure 55

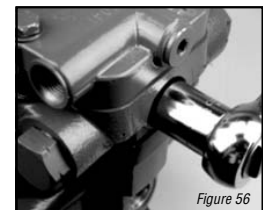

Figure 56



Figure 57



This fault - logic troubleshooting guide is a diagnostic aid in locating transmission problems.

Match the transmission symptoms with the problem statements and follow the action steps shown in the box diagrams. This will provide help in correcting minor problems eliminating unnecessary machine down time.

Following the fault - logic diagrams are diagram action comments of the action steps shown in the diagrams. Where applicable, the comment number of the statement appears in the action block of the diagrams.

### Explanatory Diagram

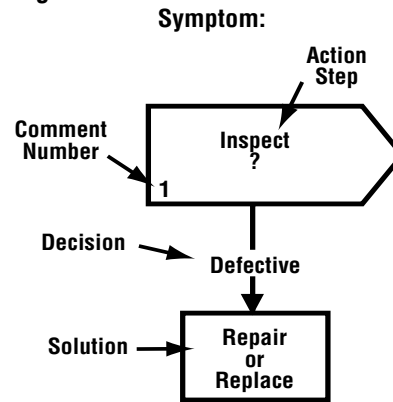

### Recommended Gauge Locations

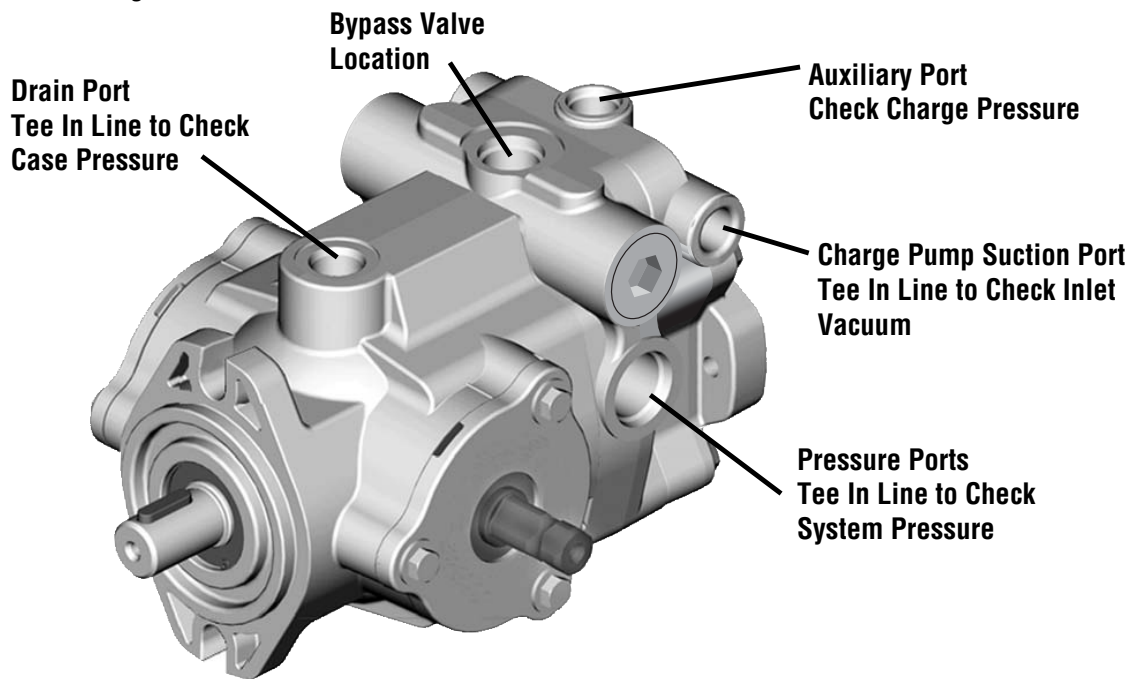
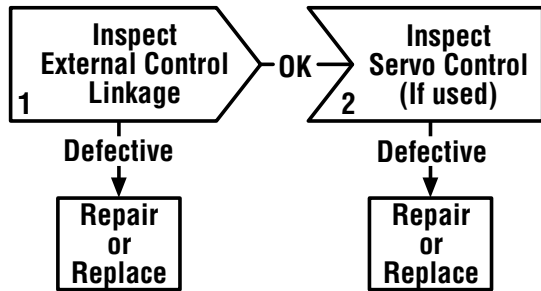

Figure 58

### Gauges Recommended

- Inlet vacuum gauge: 2 bar to 1 bar [30 PSI to 30 inHg]
- System pressure gauge: 700 bar [10,000 PSI]
- Charge pressure gauge: 0 to 50 bar [0 to 600 PSI]
- Case pressure gauge: 0 to 25 bar [0 to 300 PSI]

## Symptom: Neutral Difficult or Impossible to Find



## Symptom: System Operating Hot

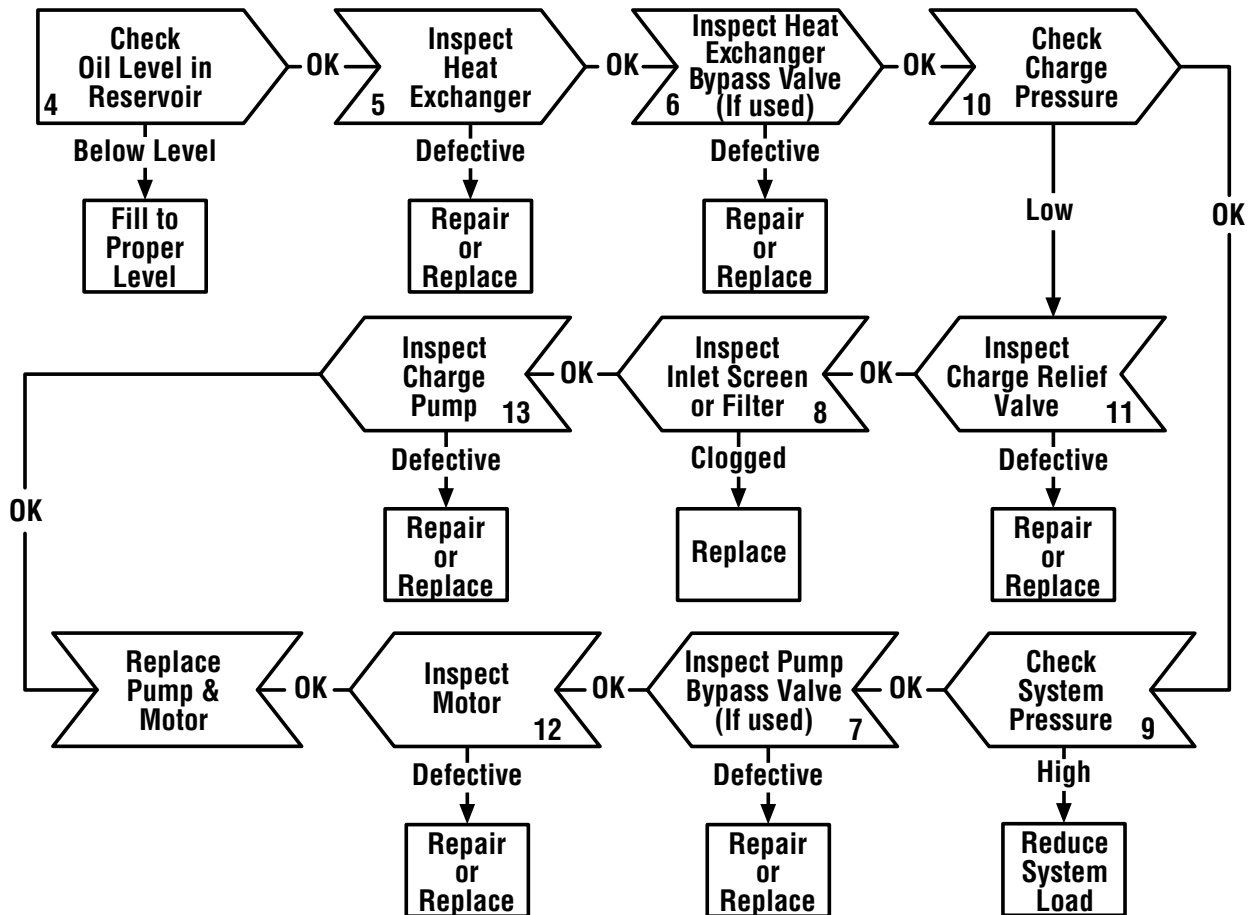

**Symptom: Operates in One Direction Only**

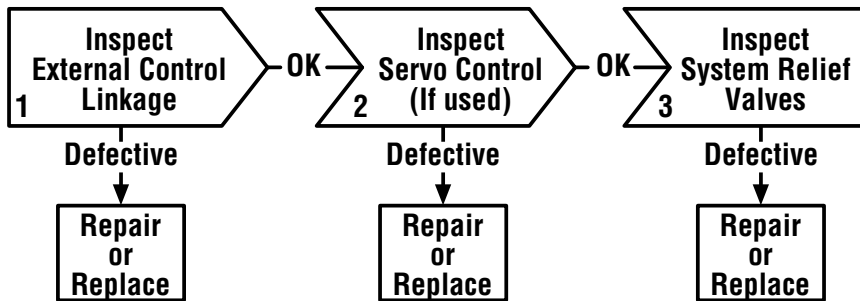

**Symptom: System Response Sluggish**

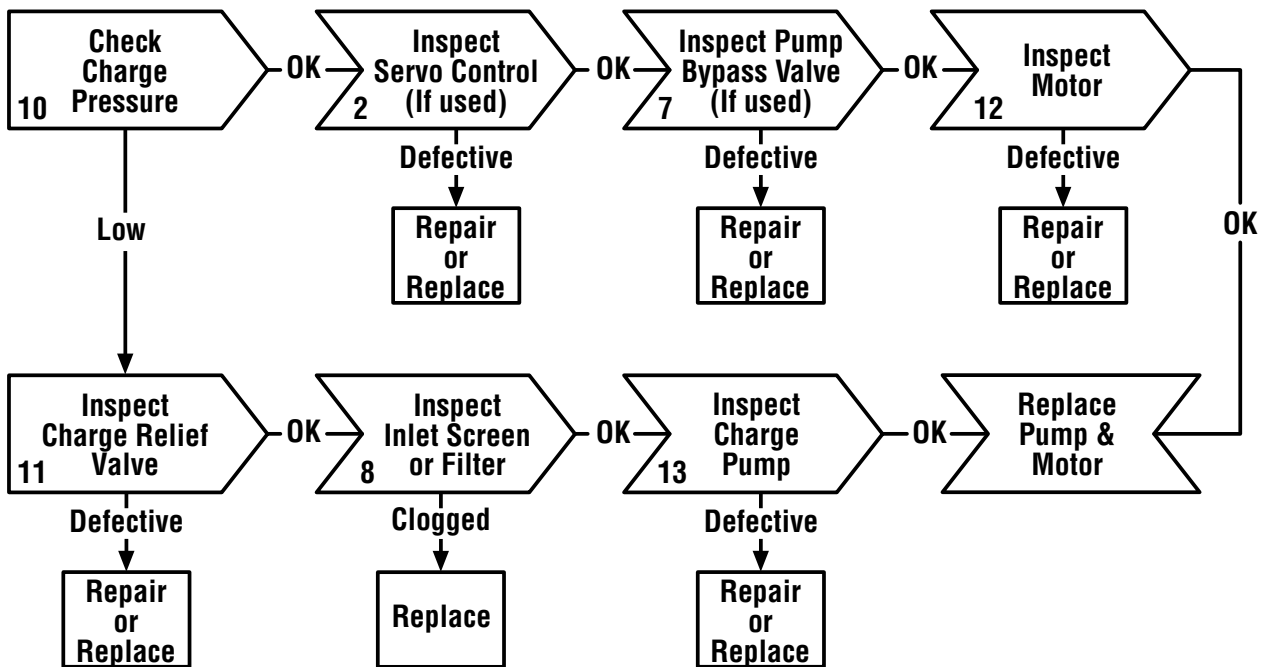

## Symptom: System Will Not Operate In Either Direction

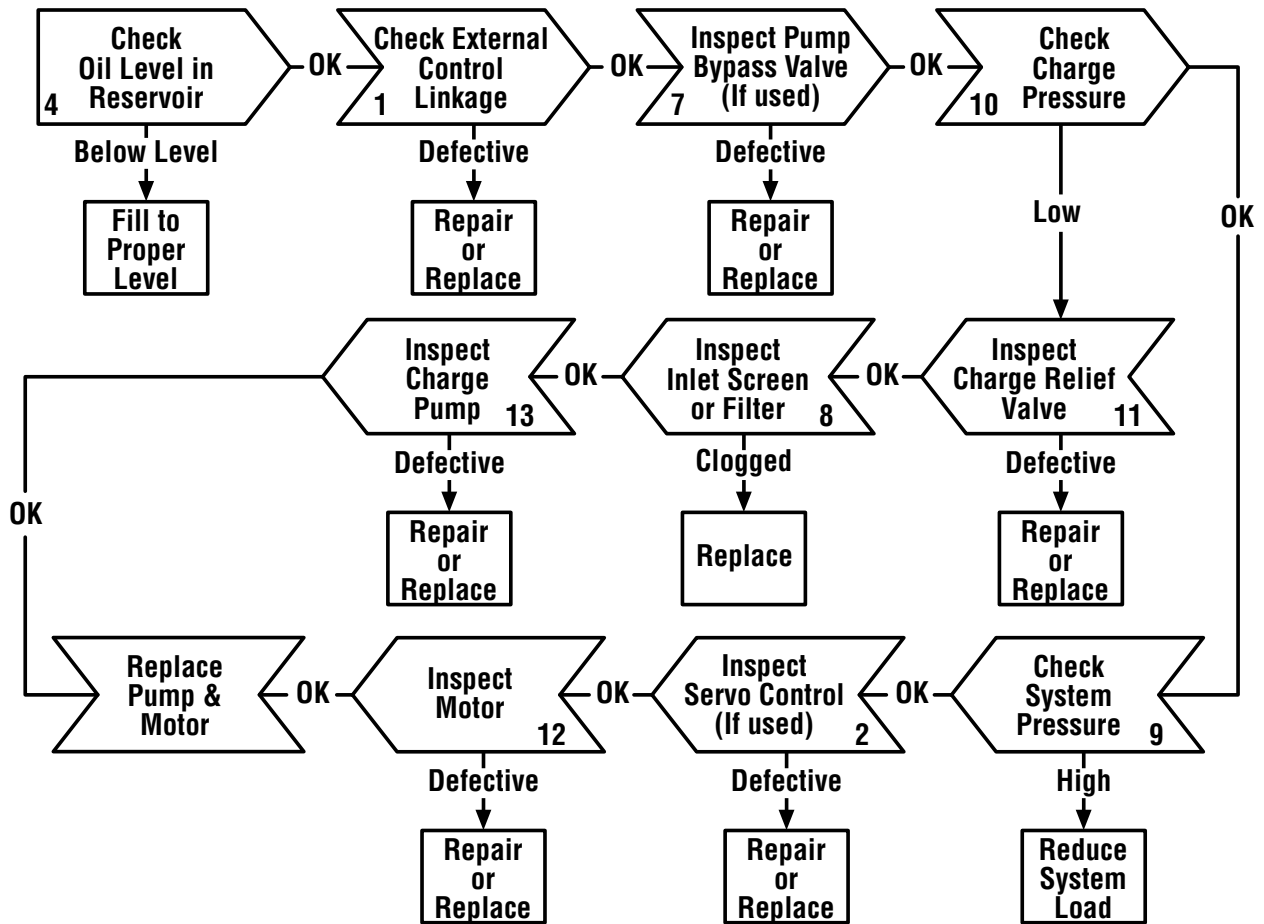



## Diagram Action Step Comments

- 1 Inspect External Control Linkage for:**
  - a. misadjustment or disconnection
  - b. binding, bending or breakage
  - c. misadjusted, damaged or broken neutral return spring
- 2 Inspect Servo Control Valve for: (if used)**
  - a. proper inlet pressure
  - b. misadjusted, damaged or broken neutral return spring
  - c. galled or stuck control spool
  - d. galled or stuck servo piston
- 3 Inspect System Relief Valves\* for:**
  - a. improper pressure relief setting
  - b. damaged or broken spring
  - c. valve held off seat
  - d. damaged valve seat
- 4 Check Oil Level in Reservoir:**
  - a. consult owner/operators manual for the proper type fluid and level
- 5 Inspect Heat Exchanger for:**
  - a. obstructed air flow (air cooled)
  - b. obstructed water flow (water cooled)
  - c. improper plumbing (inlet to outlet)
  - d. obstructed fluid flow
- 6 Inspect Heat Exchanger Bypass Valve for: (if used)**
  - a. improper pressure adjustment
  - b. stuck or broken valve
- 7 Inspect Pump Bypass Valve for: (if used)**
  - a. held in a partial or full open position
- 8 Inspect Inlet Screen or Filter for:**
  - a. plugged or clogged screen or filter element
  - b. obstructed inlet or outlet
  - c. open inlet to charge pump
- 9 Check System Pressure:**
  - a. See figure 60 for location of pressure gauge installation.
  - b. consult owner/operators manual for maximum system relief valve settings
- 10 Check Charge Pressure:**
  - a. See figure 60 for location of pressure gauge installation.
  - b. consult owner/operators manual for maximum charge relief valve settings

- 11 Inspect Charge Relief Valve for:**
  - a. improper charge relief pressure setting \*
  - b. damaged or broken spring
  - c. poppet valve held off seat
- 12 Inspect Motor for:**
  - a. disconnected coupling
- 13 Inspect Charge Pump for:**
  - a. broken or missing drive key
  - b. damaged or missing o-ring
  - c. excessive gerotor clearance
  - d. galled or broken gerotor set

### \* System/Charge Relief Valve Pressure Settings for Eaton's Variable Displacement Controlled Piston Pumps

Inlet Vacuum	6 inHg max.
Case Pressure	25 PSI maximum
Charge Pressure	100 to 150 PSI Standard 200 to 250 PSI Optional 250 to 300 PSI Optional
System Pressure	5000 PSI maximum 3000 PSI continuous

The high pressure relief valves are all factory preset and cannot be readjusted.

The pressure setting and assembly number is stamped on each high pressure relief valve cartridge.

Valve Identification Example:

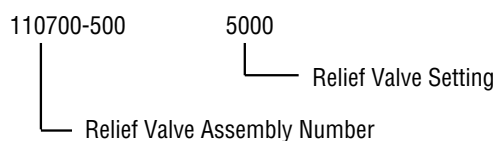

# 76-638/77-266 START-UP PROCEDURE

When starting a new or rebuilt transmission system, it is extremely important to follow the start-up procedure. It prevents the chance of damaging the unit which might occur if the system was not properly purged of air before start-up.

- 1 After the transmission components have been properly installed, fill the pump housing at least half full with filtered system oil. Connect all hydraulic lines and check to be sure they are tight.
- 2 Install and adjust all control linkage.
- 3 Fill the reservoir with an approved oil that has been filtered through a 10 micron filter. Refer to Eaton Hydraulics Technical Data Sheet number 3-401 titled [Hydraulic Fluid Recommendations](#).
- 4 For Gasoline engines or L.P. engines remove the coil wire and turn the engine over for 15 seconds. For Diesel engines shut off the fuel flow to the injectors and turn the engine over for 15 seconds.
- 5 Replace the coil wire or return the fuel flow to the injectors. Place the transmission unit in the neutral position, start the engine and run it at a low idle. The charge pump should immediately pick up oil and fill the system. If there is no indication of fill in 30 seconds, stop the engine and determine the cause.

- 6 After the system starts to show signs of fill, slowly move pump camplate to a slight cam angle. Continue to operate system slowly with no load on motors until system responds fully.
- 7 Check fluid level in the reservoir and refill if necessary to the proper level with an approved filtered oil.
- 8 Check all line connections for leaks and tighten if necessary.

The machine is now ready to be put into operation.

Frequent filter changes are recommended for the first two changes after placing the machine back into operation. Change the first filter in 3-5 hours and the second in approximately 50 hours. Routinely scheduled filter changes are recommended for maximum life of the hydraulic system.

# 76-197 EATON GEAR PUMP DRAWING

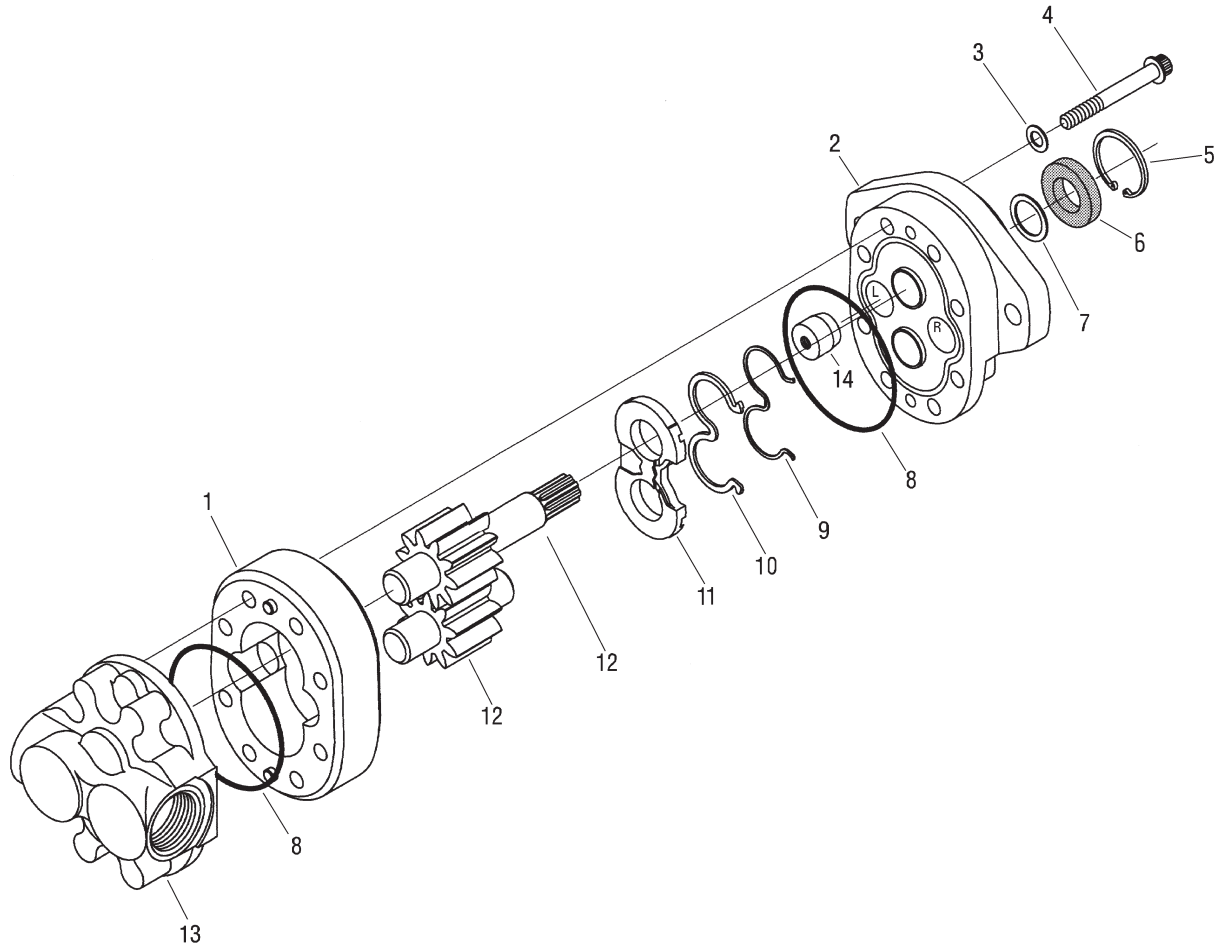

REF#	PART#	DESCRIPTION	QUANTITY
1		Body	1
2	76-197-01	Front Plate	1
3*		Washer	4
4	76-197-06	Cap Screw	8
5	76-197-07	Retaining Ring	1
6*		Shaft Seal	1
7	33-061-15	Washer	1
8*		O-Ring	2
9*		Backup Gasket	1
10*		Seal	1
11*		Wear Plate	1
12	76-197-04	Shaft (comes with Idler Gear)	1
13	76-197-02	Back Plate	1
14*		Plug	1
*	76-197-08	Seal Kit	

# 76-197 REPAIR DISSASSEMBLY INSTRUCTIONS

## Repair Information - Model 26000

Work in a clean area; cleanliness is extremely important when repairing hydraulic pumps. Before disconnecting the lines, clean port area of pump. Disconnect hydraulic lines, removing pump assembly from vehicle and plugging ports. Thoroughly clean the outside of pump. After cleaning, remove port plugs and drain oil.

## Disassembly

- 1 Remove *key* from drive shaft if keyed drive gear assembly is used.
- 2 Put a *location mark* across front plate, body and backplate to assure proper reassembly.
- 3 Clamp pump in vise, shaft end up.
- 4 Remove *cap screws* (eight each) and *washer* (four each).
- 5 Remove pump from vise, hold pump in hands and tap shaft with plastic hammer or rawhide mallet to separate front plate from backplate. Body will remain with either front plate or backplate.



- 6 Remove *o-ring* seal from backplate.

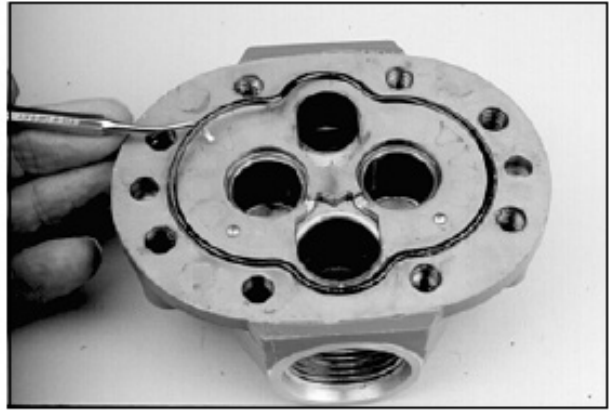

7. Remove backplate.

# 76-197 REPAIR DISASSEMBLY INSTRUCTIONS

**8** Remove *idler gear assembly* from body.

**9** To separate *body* from the plate it remained with, place *drive gear assembly* in gear pocket and tap protruding end with plastic hammer or rawhide mallet. Remove drive gear assembly.

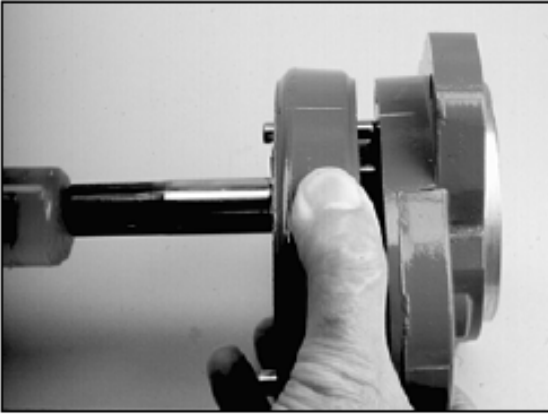

**10** Remove wear plate and o-ring seal, noting position of open side of wear plate.

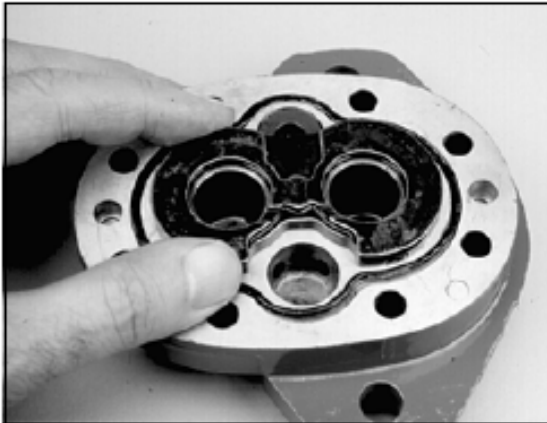

**11** Remove *back-up gasket and seal* from wear plate by extracting with a o-ring tool.



**12** Remove snap ring (if applicable) from the front of the front plate shaft seal area.

**13** Remove *shaft seal and washer* from front plate with a blunt punch from the back side.

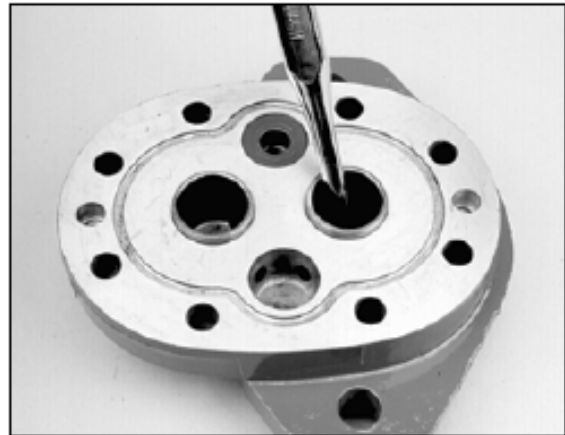

**14** Removing the *plug* in front plate is not necessary, unless you intend to change rotation. See Reversibility - Changing Input Rotation of Pump.

# 76-197 REPAIR INSPECTION

## Inspect Parts for Wear

### General

- 1 Clean and dry all parts.
- 2 Remove all nicks and burrs from all parts with emery cloth.

### Gear Assembly Inspection

- 1 Check spline drive shaft for twisted or broken teeth or check keyed drive shaft for broken or chipped keyway.
- 2 Inspect both the drive gear and idler gear shafts at bushing points and seal area for rough surfaces and excessive wear.
- 3 Replace gear assembly if shaft measures less than 19 mm [.748 in] in bushing area. (One gear assembly may be replaced separately; shafts and gears are available as assemblies only.)
- 4 Inspect gear for scoring and excessive wear.
- 5 Replace gear assembly if gear width is below the following dimensions. Refer to chart on this page.
- 6 Assure that snap rings are in grooves on either side of drive and idler gears.
- 7 If edge of gear teeth are sharp, break edge with emery cloth.

## Front plate and Backplate Inspection

- 1 Oil groove in bushings in front plate should be in line with dowel pin holes and 180° apart. The oil grooves in the backplate bushings should be at approximately 37° to the pressure side.
- 2 Replace the backplate or front plate if I.D. of bushings exceed 19,2 mm [.755 in] (Bushings are not available as separate items).
- 3 Bushings in front plate should be at 3,20 mm [.126 in] above surface of front plate.
- 4 Check for scoring on face of backplate. Replace if wear exceeds .038 mm [.0015 in].

## Body Inspection

- 1 Check body inside gear pockets for excessive scoring or wear.
- 2 Replace body if I.D. of gear pockets exceeds 43,7 mm [1.719 in].

Model Number	26001	26002	26003	26004	26005	26006	26007	26008	26009	26010	26011	26012	26013
Pump Disp. cm <sup>3</sup> /r [in <sup>3</sup> /r]	6,6 [.40]	8,2 [.50]	9,5 [.58]	10,8 [.66]	13,8 [.84]	16,7 [1.02]	19,7 [1.20]	22,5 [1.37]	24,3 [1.48]	25,2 [1.54]	27,7 [1.69]	29,0 [1.77]	30,6 [1.87]
Gear Width mm [in]	7,85 [.309]	9,75 [.384]	11,20 [.441]	12,95 [.510]	16,15 [.636]	19,35 [.762]	22,56 [.888]	25,76 [1.014]	28,12 [1.107]	28,96 [1.140]	32,16 [1.266]	33,78 [1.330]	35,36 [1.392]



## General Information

It is important that the relationship of the backplate, body, wear plate and front plate is correct. You will note two half moon cavities in the body. Note: The smaller half moon port cavity must be on the pressure side of the pump. The side of wear plate with midsection cut out must be on suction side of pump. Suction side of backplate is always side with larger port boss.

## Reassembly

- 1 During the reassembly replace the *wear plate, seal, back-up gasket, shaft seal and o-rings* as new parts.
- 2 Install *o-ring* in groove of front plate.



- 3 Apply a thin coat of petroleum jelly or hydraulic oil to both milled gear pockets of body. Slip body onto front plate with half moon port cavities in body facing away from front plate.

Note: The small half moon port cavity must be on the pressure side (the plugged side of the front plate) of pump.

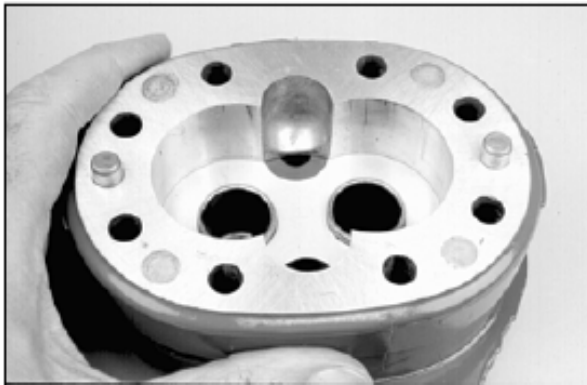

- 4 Install new *seal* and new *backup gasket* into wear plate. Note in the middle of the backup gasket a flat section or support. This area must face away from the wear plate inside the seal.



- 5 Place new *wear plate, seal, and backup gasket* into gear pocket with seal and backup gasket next to front plate. The side of the wear plate with the mid section cut-away must be on the suction side of pump.



- 6 Dip *gear assemblies* into oil and slip into front plate bushings and gears into pockets of body.

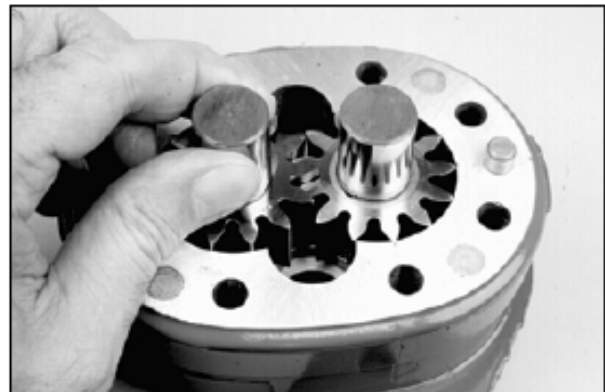

## 76-197 REPAIR REASSEMBLY INSTRUCTIONS

- 7 Install new *o-ring* in groove of backplate.

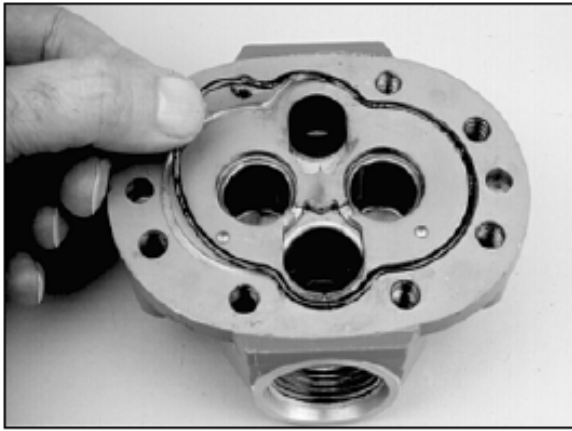

8 Make sure port orientation is correct and then slide *backplate* over gear shafts until dowel pins are engaged.

9 Secure with *cap screws* and new *washers*. Tighten cap screws evenly in a crisscross pattern 34 to 38 N•m [25 to 28 lbf•ft] torque.

10 Place washer over drive shaft into housing. Liberally oil shaft seal and install over drive shaft, carefully so that rubber sealing lips are not cut.



11 Place 1-5/16 in. O.D. sleeve over shaft and press in shaft seal until flush with front surface of front plate.

13 Install key on keyed shaft.

Note: Refer to Start-up Procedure and Trouble Shooting Procedure.

## 76-197 REPAIR TROUBLESHOOTING

Problem	Possible Cause	Correction
Cavitation	<ul style="list-style-type: none"> <li>a. Oil too heavy.</li> <li>b. Oil filter plugged.</li> <li>c. Suction line plugged or too small.</li> </ul>	<ul style="list-style-type: none"> <li>a. Change to proper viscosity</li> <li>b. Clean filter.</li> <li>c. Clean line and check size of line.</li> </ul>
Oil heating	<ul style="list-style-type: none"> <li>a. Oil supply low.</li> <li>b. Contaminated oil.</li> <li>c. Setting of relief valve too high or too low.</li> <li>d. Oil in system too light.</li> </ul>	<ul style="list-style-type: none"> <li>a. Fill reservoir.</li> <li>b. Drain reservoir and refill with clean oil.</li> <li>c. Set to correct pressure.</li> <li>d. Drain reservoir and refill with proper viscosity oil.</li> </ul>
Shaft seal leakage	<ul style="list-style-type: none"> <li>a. Worn shaft seal.</li> <li>b. Worn shaft in seal area.</li> <li>c. Debris in shaft seal suction side drain holes.</li> </ul>	<ul style="list-style-type: none"> <li>a. Replace shaft seal.</li> <li>b. Replace drive assembly.</li> <li>c. Disassemble pump and inspect.</li> </ul>
Foaming oil	<ul style="list-style-type: none"> <li>a. Low oil level</li> <li>b. Air leaking into suction line</li> <li>c. Wrong kind of oil.</li> </ul>	<ul style="list-style-type: none"> <li>a. Fill reservoir.</li> <li>b. Tighten fittings.</li> <li>c. Drain and fill reservoir with non-foaming oil.</li> </ul>



When test stand is *available*.

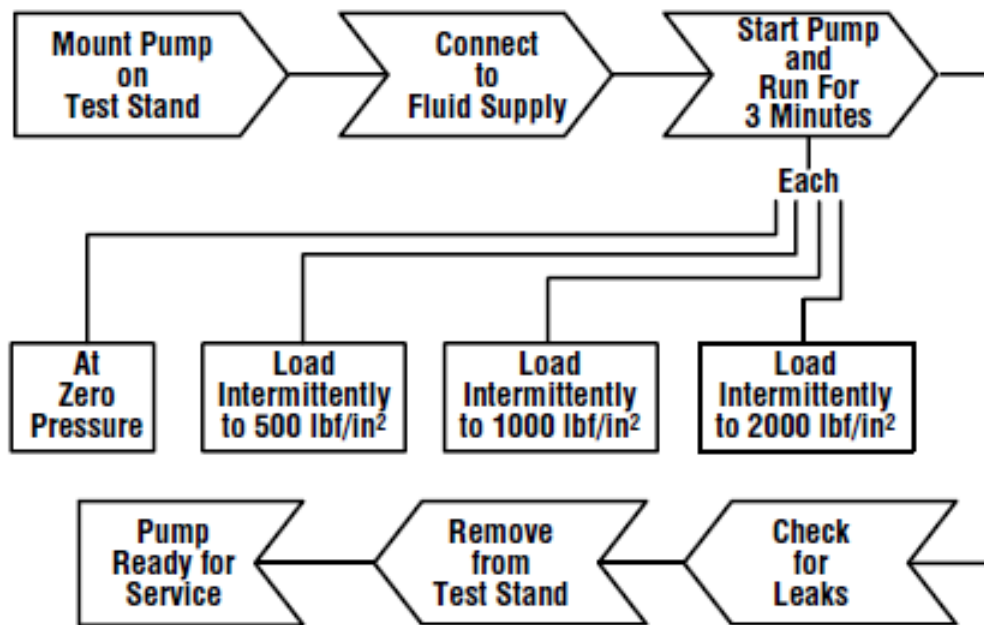

When test stand is *not available*.

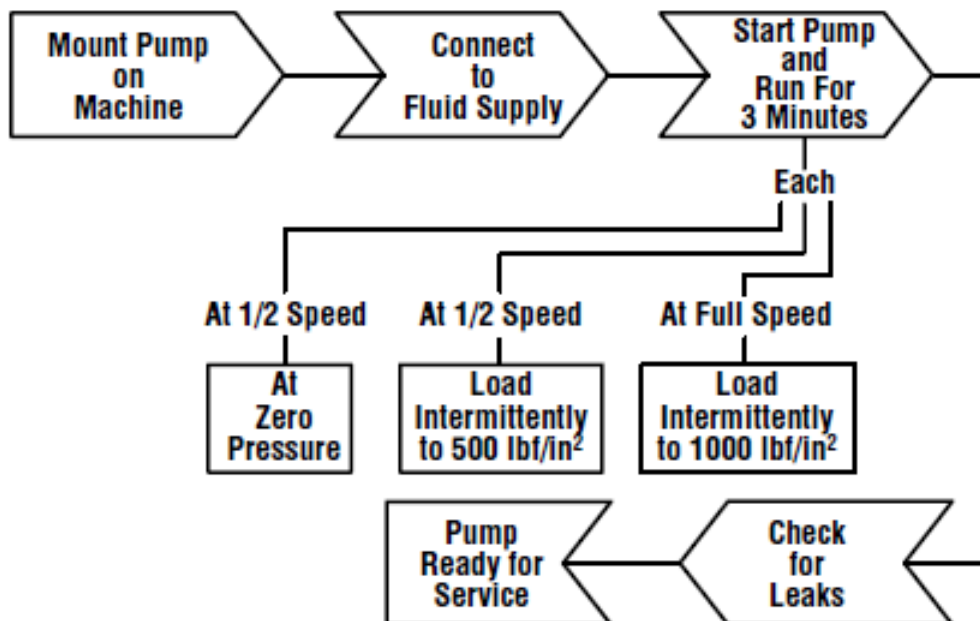

# 76-238 REAR WHEEL MOTOR DRAWING (14.5 CI)

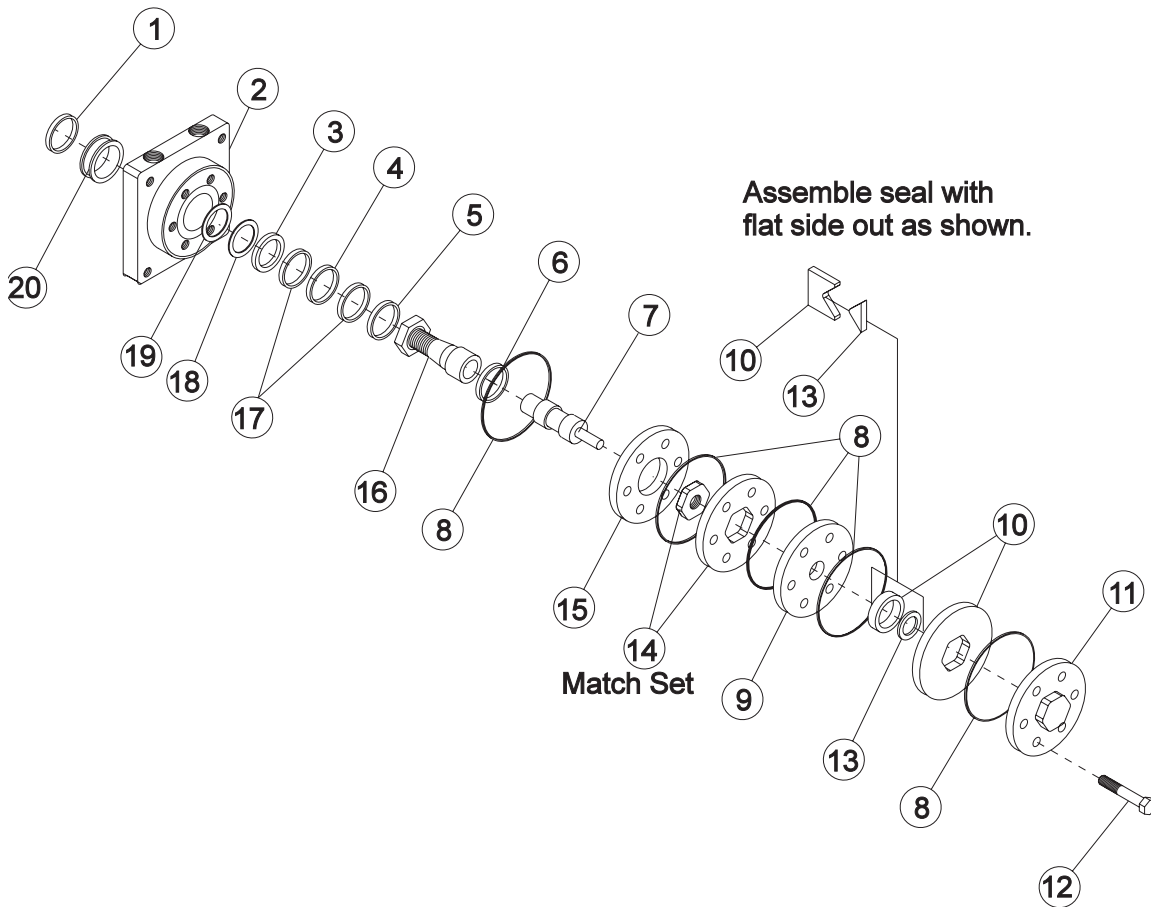

Parts

REF#	PART#	DESCRIPTION	QUANTITY
1*		Water & Dirt Seal	1
2†	13-615-05	Service Housing Assembly	1
3*		Inner Seal	1
4†	13-032-27	Thrust Bearing	1
5†	13-032-28	Inner Bearing	1
6	13-032-29	Thrust Bearing	1
7	76-238-03	Drive Link	1
8*		Ring Seal	5
9	13-032-31	Manifold	1
10	13-032-32	Commutator Assembly (matched set)	1
11	13-032-33	End Cover	1
12	76-238-01	Hex Bolt	7
13*		Commutator Seal (matches with #10)	1
14	76-238-02	Rotor Set (matched set)	1
15	13-032-35	Plate Wear	1
16	13-615-04	Coupling Shaft	1
	HWK-516-100	Woodruff Key, $\frac{5}{16}$ x 1	1
	14-265	Nut, 1 - 20	1
17†	13-032-37	Thrust Washer	2
18*		Backup Washer	1
19*		Backup Washer	1
20†	13-032-38	Outer Bearing	1
*	14-080	Seal Kit	1
†		Included in 13-615-05 Service Housing Assembly	

## 76-238 TROUBLESHOOTING CHECKLIST

Trouble	Cause	Remedy
<b>Oil Leakage</b>	1. Hose fittings loose, worn or damaged.	Check & replace damaged fittings or “O” Rings. Torque to manufacturers specifications.
	2. Oil seal rings (4) deteriorated by excess heat.	Replace oil seal rings by disassembling Torqmotor™ unit.
	3. Special bolt (1, 1A, 1B or 1C) loose or its sealing area deteriorated by corrosion.	(a) Loosen then tighten single bolt to torque specification. (b) Replace bolt.
	4. Internal shaft seal (16) worn or damaged.	Replace seal. Disassembly of Torqmotor™ unit necessary.
	5. Worn coupling shaft (12) and internal seal (16).	Replace coupling shaft and seal by disassembling Torqmotor™ unit.
<b>Significant loss of speed under load</b>	1. Lack of sufficient oil supply	(a) Check for faulty relief valve and adjust or replace as required. (b) Check for and repair worn pump. (c) Check for and use correct oil for temperature of operation.
	2. High internal motor leakage	Replace worn rotor set by disassembling Torqmotor™ unit.
	3. Severely worn or damaged internal splines.	Replace rotor set, drive link and coupling shaft by disassembling Torqmotor™ unit.
	4. Excessive heat.	Locate excessive heat source (usually a restriction) in the system and correct the condition.
<b>Low mechanical efficiency or undue high pressure required to operate Torqmotor™ unit</b>	1. Line blockage	Locate blockage source and repair or replace.
	2. Internal interference	Disassemble Torqmotor™ unit, identify and remedy cause and repair, replacing parts as necessary.
	3. Lack of pumping pressure	Check for and repair worn pump.
	4. Excessive binding or loading in system external to Torqmotor™ unit.	Locate source and eliminate cause.

**CAUTION:** If the hydraulic system fluid becomes overheated [in excess of 200°F (93.3°C)], seals in the system can shrink, harden or crack, thus losing their sealing ability.

# 76-238 SERVICING TOOL LIST

- Clean, petroleum-based solvent
- Emery paper
- Vise with soft jaws
- Air pressure source
- Arbor press
- Screw driver
- Masking tape
- Breaker bar
- Torque wrench-ft. lbs. (N m)
- Sockets: 1/2 or 9/16 inch thin wall, 1 inch
- Allen Sockets: 3/16, 3/8 inch
- Adjustable crescent wrench or hose fitting wrenches
- SAE 10W40 SE or SF oil
- Special bearing mandrel for TH Torqmotors (consult factory)
- Special bearing mandrel for TF, TG & TJ Torqmotors (SEE FIGURE 1)
- Feeler gage .005 inch (.13 mm)
- TH Torqmotors require blind hole bearing puller for a 1.575 inch dia. (40.0 mm) and 2.130 inch dia. (54.1 mm) bearings.
- TF, TG & TL Torqmotors require blind hole bearing puller for 1.400 inch dia. (35.6 mm) and 2.130 inch dia. (54.1 mm) bearings.
- Clean corrosion resistant grease. Part #406018 is included in each seal kit. Recommended grease is Parker Specification #045236 or Mobil Mobilith SHC® 460

**NOTE: The available service seal kits include the recommended grease as a grease pack #406018**

**CAUTION: Mixing greases that have different bases can be detrimental to bearing life.**

## Torque Chart

Part Name	Item Number	Torque
bolt 3/8 24 UNF 2A	1, 1A, 1B or 1C	45-55 ft. lbs. (60-76 N m)
bolt 5/8 18 UNF 2A	12D	140-180 ft. lbs. (190-244 N m)
nut 1-20 UNEF 2B	12B (TF, TG, TL)	300-400 ft. lbs. (407-542 N m)

# 76-238 ASSEMBLY REFERENCE DRAWING

## Typical Assembly

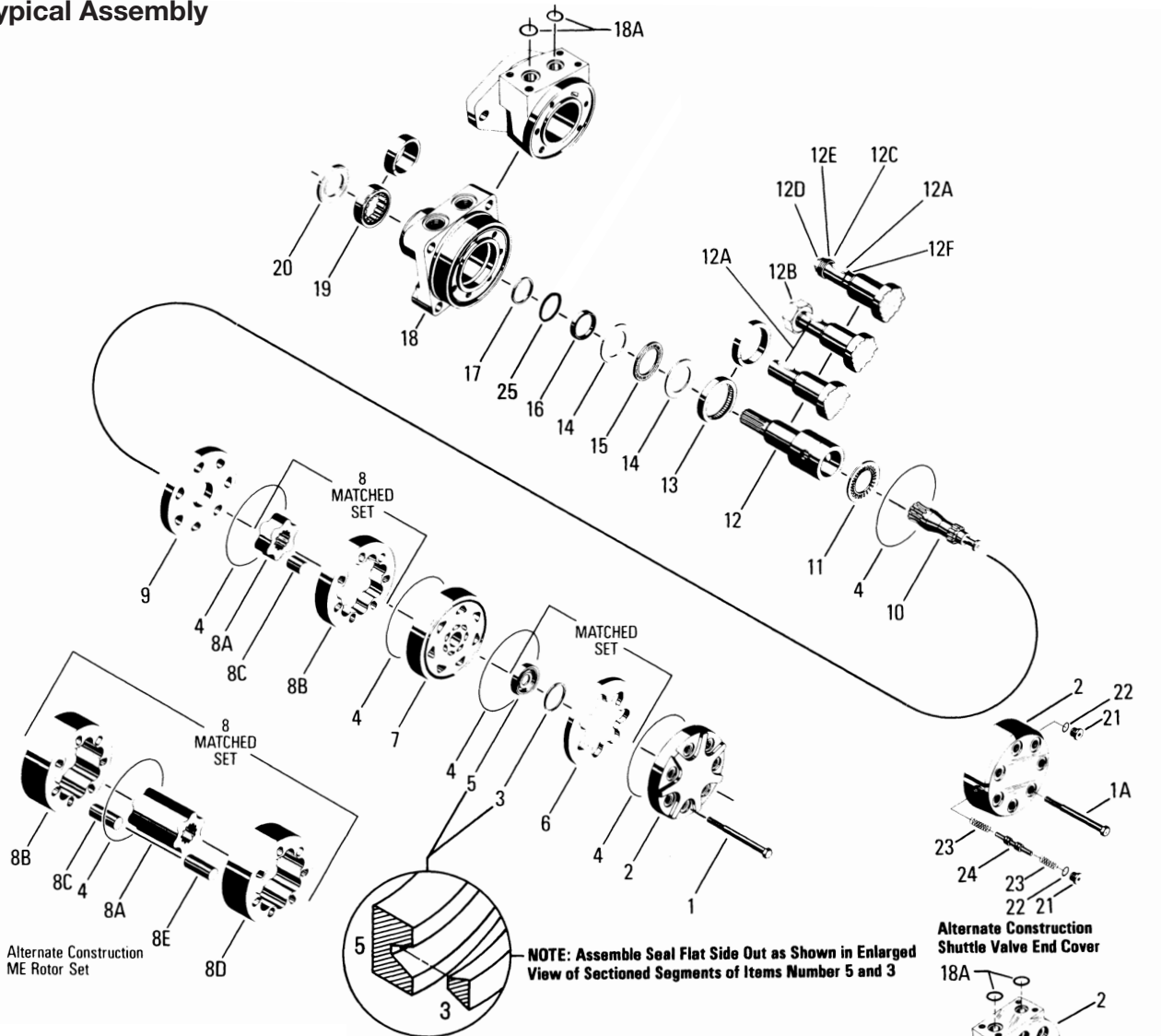

### Item

#### No. Description

- |                               |                     |                               |
|-------------------------------|---------------------|-------------------------------|
| 1. Special Bolts (5, 6, or 7) | 9. Wear Plate       | 18. Housing                   |
| 1a. Special Bolts (7)         | 10. Drive Link      | 18a. O-Ring (2)               |
| 1b. Special Bolts (7)         | 11. Thrust Bearing  | 19. Bearing, Outer            |
| 1c. Special Bolts (7)         | 12. Coupling Shaft  | 20. Dirt & Water Seal         |
| 2. End Cover                  | 12a. Key            | 21. Plug (2)                  |
| 3. Seal Ring-Commutator       | 12b. Nut            | 22. O-Ring (2)                |
| 4. Seal Ring (5)              | 12c. Washer         | 23. Spring                    |
| 5. Commutator                 | 12d. Bolt           | 24. Valve (Shuttle or Relief) |
| 6. Commutator Ring            | 12e. Lockwasher     | 25. Backup Washer             |
| 7. Manifold                   | 12f. Retaining Ring |                               |
| 8. Rotor Set                  | 13. Bearing, Inner  |                               |
| 8a. Rotor                     | 14. Thrust Washer   |                               |
| 8b. Stator or Stator Half     | 15. Thrust Bearing  |                               |
| 8c. Vane (7)                  | 16. Seal            |                               |
| 8d. Stator Half               | 17. Backup Ring     |                               |
| 8e. Vane (7)                  |                     |                               |

= Items not sold separately. Sold as matched sets only.

## Preparation Before Disassembly

- Before you disassemble the Torqmotor™ unit or any of its components read this entire manual. It provides important information on parts and procedures you will need to know to service the Torqmotor™.
- Determine the type of end construction from the alternate views shown on the exploded view.
- The Series TF, TG, TL & TH Torqmotors™ will have a 5 inch (127.9 mm) main body outside diameter and seven 3/8 24 UNF 2A cover bolts.
- Refer to “Tools and Materials Required for Services” section for tools and other items required to service the Torqmotor™ and have them available.
- Thoroughly clean off all outside dirt, especially from around fittings and hose connections, before disconnecting and removing the Torqmotor™. Remove rust or corrosion from coupling shaft.
- Remove coupling shaft connections and hose fittings and immediately plug port holes and fluid lines.
- Remove the Torqmotor™ from system, drain it of fluid and take it to a clean work surface.
- Clean and dry the Torqmotor™ before you start to disassemble the unit.
- As you disassemble the Torqmotor™ clean all parts, except seals, in clean petroleum-based solvent, and blow them dry.

WARNING: petroleum-base solvents are flammable. Be extremely careful when using any solvent. Even a small explosion or fire could cause injury or death.

WARNING: WEAR EYE PROTECTION AND BE SURE TO COMPLY WITH OSHA OR OTHER MAXIMUM AIR PRESSURE REQUIREMENTS.

CAUTION: Never steam or high pressure wash hydraulic components. Do not force or abuse closely fitted parts.

- Keep parts separate to avoid nicks and burrs.
- Discard all seals and seal rings as they are removed from the Torqmotor™. Replace all seals, seal rings and any damaged or worn parts with genuine Parker or OEM approved service parts.

## Reference Exploded Assembly View

**Place Torqmotor in a vise**

1. Place the Torqmotor™ in a soft jawed vise, with coupling shaft (12) pointed down and the vise jaws clamping firmly on the sides of the housing (18) mounting flange or port bosses. Remove manifold port O-Rings (18A) if applicable.

**WARNING**

**WARNING: IF THE TORQMOTOR™ IS NOT FIRMLY HELD IN THE VISE, IT COULD BE DISLODGED DURING THE SERVICE PROCEDURES, CAUSING INJURY.**

**Scribe alignment mark & loose valve plugs**

2. Scribe an alignment mark down and across the Torqmotor™ components from end cover (2) to housing (18) to facilitate reassembly orientation where required. Loosen two shuttle or relief valve plugs (21) for disassembly later if included in end cover. 3/16 or 3/8 inch Allen wrench or 1 inch hex socket required. SEE FIGURES 2 & 3.

**Remove special bolts & inspect bolts**

3. Remove the seven special ring head bolts (1, 1A, 1B, or 1C) using an appropriate 9/16 inch size socket. SEE FIGURE 4. Inspect bolts for damaged threads, or sealing rings, under the bolt head. Replace damaged bolts. SEE FIGURE 5.

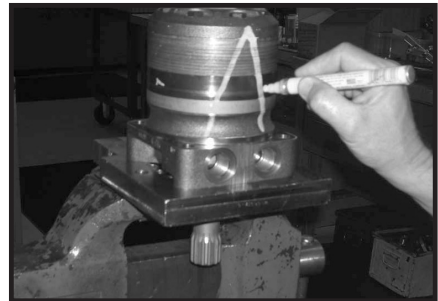

Figure 2

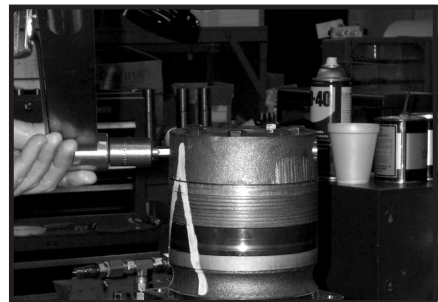

Figure 3

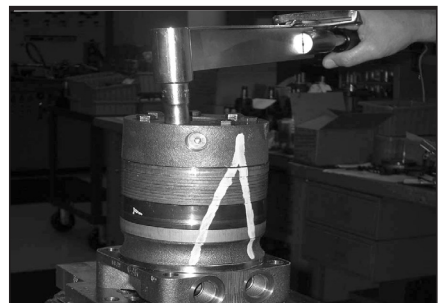

Figure 4



Figure 5



# 76-238 DISASSEMBLY INSTRUCTIONS

**Remove end cover & inspect bolts**

4. Remove end cover assembly (2) and seal ring (4). Discard seal ring. SEE FIGURE 6.

**NOTE**

**NOTE:** Refer to the appropriate “alternate cover construction” on the exploded view to determine the end cover construction being serviced.



Figure 6

**Remove plugs and valves**

5. If the end cover (2) is equipped with shuttle valve or relief valve (24) components, remove the two previously loosened plugs (21) and o-rings (22). SEE FIGURE 7.

**CAUTION**

**CAUTION:** Be ready to catch the shuttle valve or relief valve components that will fall out of the end cover valve cavity when the plugs are removed.

**NOTE**

**NOTE:** O-ring (22) is not included in seal kits but serviced separately if required.

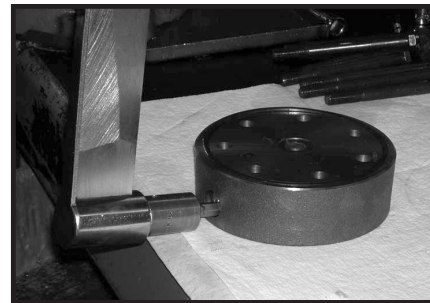

Figure 7

**NOTE**

**NOTE:** The insert and if included the orifice plug in the end cover (2) must not be removed as they are serviced as an integral part of the end cover.

**Wash & inspect end cover**

6. Thoroughly wash end cover (2) in proper solvent and blow dry. Be sure the end cover valve apertures, including the internal orifice plug, are free of contamination. Inspect end cover for cracks and the bolt head recesses for good bolt head sealing surfaces. Replace end cover as necessary. SEE FIGURE 8.

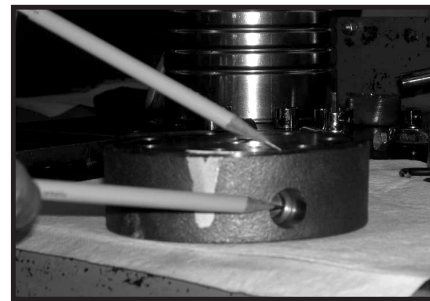

Figure 8

**NOTE**

**NOTE:** A polished pattern (not scratches) on the cover from rotation of the commutator (5) is normal. Discoloration would indicate excess fluid temperature, thermal shock, or excess speed and require system investigation for cause and close inspection of end cover, commutator, manifold, and rotor set.

**Remove & inspect commutator ring**

7. Remove commutator ring (6). SEE FIGURE 9. Inspect commutator ring for cracks, or burrs.



Figure 9



**Remove & inspect commutator**

- Remove commutator (5) and seal ring (3). Remove seal ring from commutator, using an air hose to blow air into ring groove until seal ring is lifted out and discard seal ring. Inspect commutator for cracks or burrs, wear, scoring, spalling or brinelling. If any of these conditions exist, replace commutator and commutator ring as a matched set. SEE FIGURE 10 & 11.



Figure 10

**Remove manifold**

- Remove manifold (7) and inspect for cracks surface scoring, brinelling or spalling. Replace manifold if any of these conditions exist. SEE FIGURE 12. A polished pattern on the ground surface from commutator or rotor rotation is normal. Remove and discard the seal rings (4) that are on both sides of the manifold.



Figure 11

**NOTE**

**NOTE: The manifold is constructed of plates bonded together to form an integral component not subject to further disassembly for service. Compare configuration of both sides of the manifold to ensure that same surface is reassembled against the rotor set.**

**Remove & inspect rotor set & wearplate**

- Remove rotor set (8) and wearplate (9), together to retain the rotor set in its assembled form, maintaining the same rotor vane (8C) to stator (8B) contact surfaces. SEE FIGURE 13. The drive link (10) may come away from the coupling shaft (12) with the rotor set, and wearplate. You may have to shift the rotor set on the wearplate to work the drive link out of the rotor (8A) and wearplate. SEE FIGURE 14. Inspect the rotor set in its assembled form for nicks, scoring, or spalling on any surface and for broken or worn splines. If the rotor set component requires replacement, the complete rotor set must be replaced as it is a matched set. Inspect the wearplate for cracks, brinelling, or scoring. Discard seal ring (4) that is between the rotor set and wearplate.

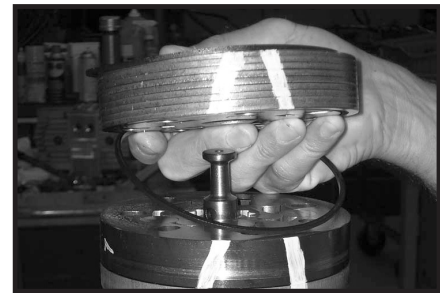

Figure 12

**NOTE**

**NOTE: The rotor set (8) components may become disassembled during service procedures. Marking the surface of the rotor and stator that is facing UP, with etching ink or grease pencil before removal from Torqmotor™ will ensure correct reassembly of rotor into stator and rotor set into Torqmotor™. Marking all rotor components and mating spline components for exact repositioning at assembly will ensure maximum wear life and performance of rotor set and Torqmotor™.**



Figure 13

# 76-238 DISASSEMBLY INSTRUCTIONS

**NOTE**

**NOTE:** Series TG or TH may have a rotor set with two stator halves (8B & 8D) with a seal ring (4) between them and two sets of seven vanes (8C & 8E). Discard seal ring only if stator halves become disassembled during the service procedures.



Figure 14

**NOTE**

**NOTE:** A polished pattern on the wear plate from rotor rotation is normal.

**Check rotor, vane clearance**

11. Place rotor set (8) and wear plate (9) on a flat surface and center rotor (8A) in stator (8B) such that two rotor lobes (180 degrees apart) and a roller vane (8C) centerline are on the same stator centerline. Check the rotor lobe to roller vane clearance with a feeler gage at this common centerline. If there is more than .005 inches (0.13 mm) of clearance, replace rotor set. SEE FIGURE 15.

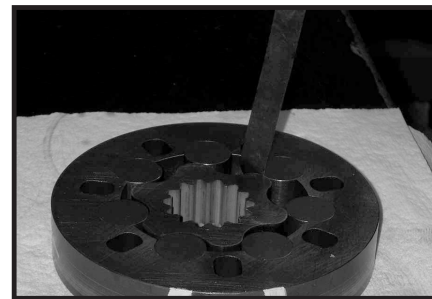

Figure 15

**NOTE**

**NOTE:** If rotor set (8) has two stator halves (8B & 8D) and two sets of seven vanes (8C & 8E) as shown in the alternate construction TG rotor set assembly view, check the rotor lobe to roller vane clearance at both ends of rotor.

**Remove & inspect drive link**

12. Remove drive link (10) from coupling shaft (12) if it was not removed with rotor set and wear plate. Inspect drive link for cracks and worn or damaged splines. No perceptible lash (play) should be noted between mating spline parts. SEE FIGURE 16. Remove and discard seal ring (4) from housing (18).



Figure 16

**Remove thrust bearing**

13. Remove thrust bearing (11) from top of coupling shaft. Inspect for wear, brinelling, corrosion and a full complement of retained rollers. SEE FIGURE 17.

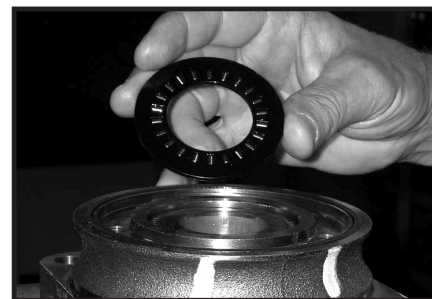

Figure 17

## Check coupling shaft for rust or corrosion

14. Check exposed portion of coupling shaft (12) to be sure you have removed all signs of rust and corrosion which might prevent its withdrawal through the seal and bearing. Crocus cloth or fine emery paper may be used. SEE FIGURE 18. Remove any key (12A), nut (12B), washer (12C), bolt (12D), lock washer (12E), or retaining ring (12F).

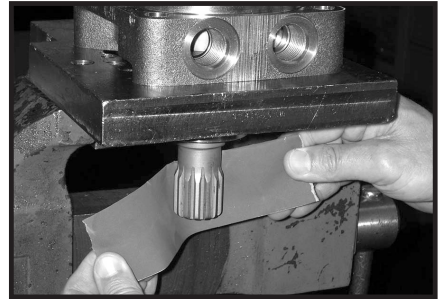

Figure 18

## Remove & inspect coupling shaft

15. Remove coupling shaft (12), by pushing on the output end of shaft. SEE FIGURE 19. Inspect coupling shaft bearing and seal surfaces for spalling, nicks, grooves, severe wear or corrosion and discoloration. Inspect for damaged or worn internal and external splines or keyway. SEE FIGURE 20. Replace coupling shaft if any of these conditions exist.



Figure 19

## NOTE

**NOTE: Minor shaft wear in seal area is permissible. If wear exceeds .020 inches (0.51 mm) diametrically, replace coupling shaft.**

## NOTE

**NOTE: A slight "polish" is permissible in the shaft bearing areas. Anything more would require coupling shaft replacement.**

## Remove seal ring from housing

16. Remove and discard seal ring (4) from housing (18).



Figure 20

# 76-238 DISASSEMBLY INSTRUCTIONS

## Remove shaft seal, backup washer & backup ring

17. Remove shaft seal (16), backup ring (17), and backup washer (25) from housing by working them around unseated thrust washers (14) and thrust bearing (15) and out of the housing. Discard seal and washers. SEE FIGURE 21.

## NOTE

**NOTE:** The original design units of Torqmotors™ did not include backup washer (25), but must include backup washer (25) when reassembled for service.



Figure 21

## Remove dirt & water seal

18. Remove housing (18) from vise, invert it and remove and discard dirt & water seal (20). A blind hole bearing or seal puller is required. SEE FIGURE 22.



Figure 22

## Inspect housing assembly

19. Inspect housing (18) assembly for cracks, the machined surfaces for nicks, burrs, brinelling or corrosion. Remove burrs that can be removed without changing dimensional characteristics. Inspect tapped holes for thread damage. SEE FIGURE 23. If the housing is defective in these areas, discard the housing assembly.

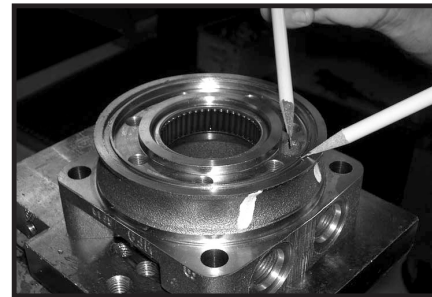

Figure 23

## Inspect housing bearing

20. If the housing (18) assembly has passed inspection to this point, inspect the housing bearings (19) and (13) and if they are captured in the housing cavity the two thrust washers (14) and thrust bearing (15). The bearing rollers must be firmly retained in the bearing cages, but must rotate and orbit freely. All rollers and thrust washers must be free of brinelling and corrosion. SEE FIGURE 24. A bearing, or thrust washer that does not pass inspection must be replaced. If the housing has passed this inspection the disassembly of the Torqmotor™ is completed.



Figure 24

## NOTE

**NOTE:** The depth or location of bearing (13) in relation to the housing wear plate surface and the depth or location of bearing (19) in relation to the beginning of bearing counter bore should be measured and noted before removing the bearings. This will facilitate the correct reassembly of new bearings. SEE FIGURE 25.

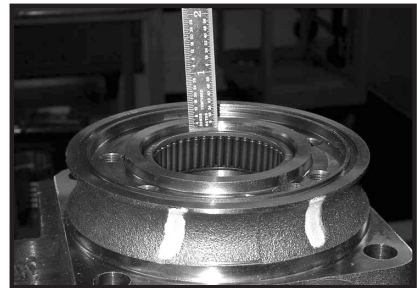

Figure 25

## Remove bearings and thrust washers

21. If the bearings or thrust washers must be replaced use a suitable size bearing puller to remove bearing (19) and (13) from housing (18) without damaging the housing. Remove thrust washers (14) and thrust bearing (15) and inspect. SEE FIGURES 26 & 27.



Figure 26



Figure 27

THE DISASSEMBLY OF TORQMOTOR™ IS COMPLETED.



# 76-238 ASSEMBLY INSTRUCTIONS

- Replace all seals and seal rings with new ones each time you reassemble the Torqmotor™ unit. Lubricate all seals and seal rings with SAE 10W40 oil or clean grease before assembly.
- **NOTE: Individual seals and seal rings as well as a complete seal kit are available. SEE FIGURE 28. The parts should be available through most OEM parts distributors or Parker approved Torqmotor™ distributors. (Contact your local dealer for availability).**
- **NOTE: Unless otherwise indicated, do not oil or grease parts before assembly.**
- Wash all parts in clean petroleum-based solvents before assembly. Blow them dry with compressed air. Remove any paint chips from mating surfaces of the end cover, commutator set, manifold rotor set, wear plate and housing and from port and sealing areas.

**WARNING**

**WARNING: SINCE THEY ARE FLAMMABLE, BE EXTREMELY CAREFUL WHEN USING ANY SOLVENT. EVEN A SMALL EXPLOSION OR FIRE COULD CAUSE INJURY OR DEATH.**

**WARNING**

**WARNING: WEAR EYE PROTECTION AND BE SURE TO COMPLY WITH OSHA OR OTHER MAXIMUM AIR PRESSURE REQUIREMENTS.**

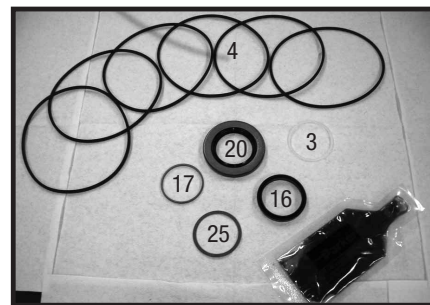

Figure 28

**Place housing into soft-jawed vise**

1. Clamp the housing into a soft-jawed vise or similar support with the coupling shaft bore down, clamping against the mounting flange.

**Press in outer bearing**

2. If the housing (18) bearing components were removed for replacement, thoroughly coat and pack a **new** outer bearing (19) with clean corrosion resistant grease recommended in the material section. Press the new bearing into the counterbore at the mounting flange end of the housing, using the appropriate sized bearing mandrel such as described in figure 1 or figure 2 which will control the bearing depth.

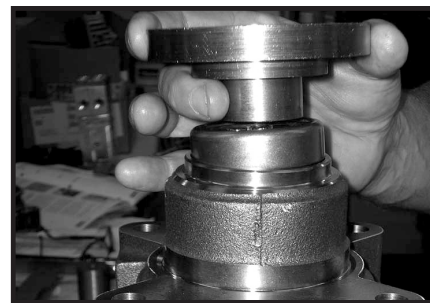

Figure 29

Torqmotor™ housings require the use of the bearing mandrel shown in figure 2 to press bearing (19) into the housing to a required depth of .290/.310 inches (7.37/7,87 mm) from the outside end of the bearing counterbore. SEE FIGURE 29.

Series TH Torqmotor housings require the use of a bearing mandrel. Consult factory for specifications.

**NOTE**                      **NOTE:** Bearing mandrel must be pressed against the lettered end of bearing shell. Take care that the housing bore is square with the press base and the bearing is not cocked when pressing a bearing into the housing.

**CAUTION**                      **CAUTION:** If the bearing mandrel specified in the “Tools and Materials Required for Servicing” section is not available and alternate methods are used to press in bearing (13) and (19) the bearing depths specified must be achieved to insure adequate bearing support and correct relationship to adjacent components when assembled.

**CAUTION**                      **CAUTION:** Because the bearing (13) and (19) have a press fit into the housing they must be discarded when removed. They must not be reused.

**Press in dirt & water seal**

3. Press a **new** dirt and water seal (20) into the housing (18) outer bearing counterbore.

The dirt and water seal (20) must be pressed in with the lip facing out and until the seal is flush to .020 inches (.51 mm) below the end of housing. SEE FIGURE 30.



Figure 30

# 76-238 ASSEMBLY INSTRUCTIONS

## Place housing assembly into vise

4. Invert housing (18) assembly into a soft jawed vise with the coupling shaft bore down, clamping against the mounting flange. SEE FIGURE 31.

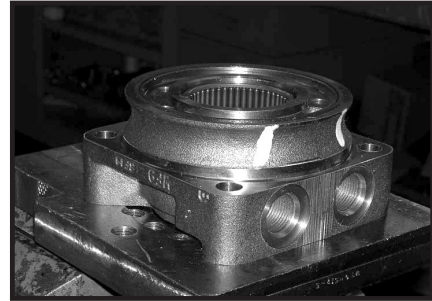

Figure 31

## Press in inner bearing

5. The Torqmotor™ housing (18) requires that you assemble a **new** backup ring (17), **new** backup washer (25) & a **new** shaft seal (16), with the lip facing to the inside of Torqmotor (see figure 69A), thrust washer (14), thrust bearing (15) and a second thrust washer (14) in that order before pressing in the inner housing bearing (13). SEE FIGURE 32 & 33. When these components are in place, press **new** bearing (13) into the housing (18) to a depth of .105/.125 inches (2.67/3.18) below the housing wear plate contact face. Use the opposite end of the bearing mandrel used to press in outer bearing (19). Reference figure 2, in the “Tools and Materials Required for Servicing” section. SEE FIGURE 34.



Figure 32



Figure 33



Figure 34



- Assemble backup washer & seal** 6. A housing (18) that did not require replacement of the bearing package will require that the two “captured” thrust washers (14) and thrust bearing (15) be unseated and vertical to the counterbore and the **new** backup ring (17), **new** backup washer (25), and **new** seal (16) be worked around the thrust bearing package and placed into their respective counterbores. The seal lip must face out of the seal counterbore and toward the inside of Torqmotor™ (see figure 60). Be sure the thrust bearing package is resealed correctly after assembly of the seal and backup washer. SEE FIGURES 35 & 36.

**CAUTION**

**CAUTION: Original design TF & TG Torqmotors™ that do not have backup washer (25) when disassembled must be assembled with a new backup ring (17), new backup washer (25), and new seal (16).**



Figure 35

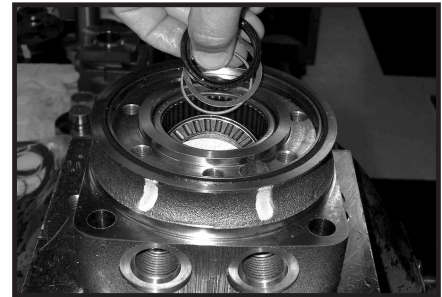

Figure 36

- Apply masking tape to shaft** 7. Apply masking tape around splines or keyway on shaft (12) to prevent damage to seal. SEE FIGURE 37.

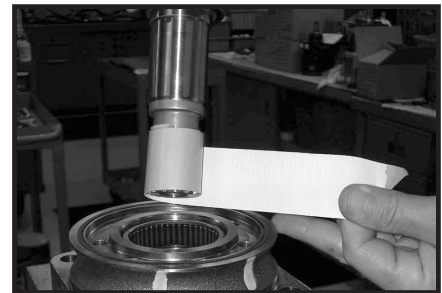

Figure 37

# 76-238 ASSEMBLY INSTRUCTIONS

## Install coupling shaft

8. Be sure that a generous amount of clean corrosion resistant grease has been applied to the lower (outer) housing bearing (19). Install the coupling shaft (12) into housing (18), seating it against the second thrust washer (14). SEE FIGURE 38.

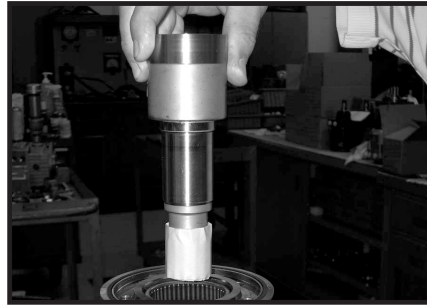

Figure 38

## CAUTION

**CAUTION:** The outer bearing (19) is not lubricated by the system's hydraulic fluid. Be sure it is thoroughly packed with the recommended grease, Parker Gear grease specification #045236, E/M Lubricant #K-70M.

## NOTE

**NOTE:** Mobil Mobilith SHC ® 460  
**NOTE:** A 102 Tube (P/N 406010) is included in each seal kit.

## NOTE

**NOTE:** The coupling shaft (12) will be approximately .10 inch (2.54 mm) below the housing wear plate surface to allow the assembly of thrust bearing (11). The coupling shaft must rotate smoothly on the thrust bearing package. SEE FIGURE 39.



Figure 39

## Install thrust bearing

9. Install thrust bearing (11) onto the end of coupling shaft (12) only if you are servicing. SEE FIGURE 40.



Figure 40

## Insert seal ring

10. Apply a small amount of clean grease to a **new** seal ring (4) and insert it into the housing (18) seal ring groove. SEE FIGURE 41.



Figure 41

- Install drive link** 11. Install drive link (10) the long splined end down into the coupling shaft (12) and engage the drive link splines into mesh with the coupling shaft splines. SEE FIGURE 42.



Figure 42

**NOTE** **NOTE: Use any alignment marks put on the coupling shaft and drive link before disassembly to assemble the drive link splines in their original position in the mating coupling shaft splines.**

- Assemble wear plate and seal ring** 12. Assemble wear plate (9) over the drive link (10) and alignment studs onto the housing (18). SEE FIGURE 43.



Figure 43

Apply a small amount of clean grease to a new seal ring (4) and assemble it into the seal ring groove on the wear plate side of the rotor set stator (8B). SEE FIGURE 44.

- Install the assembled rotor set and seal ring** 13. Install the assembled rotor set (8) onto wear plate (9) with rotor (8A) counterbore and seal ring side down and the splines into mesh with the drive link splines. SEE FIGURE 45.

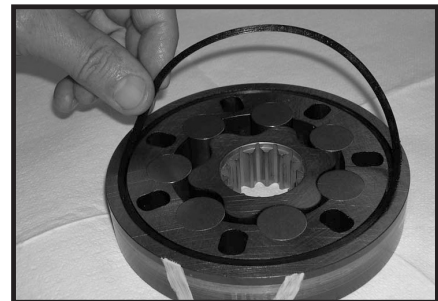

Figure 44

**NOTE** **NOTE: If necessary, go to the appropriate, "Rotor Set Component Assembly Procedure."**

**NOTE** **NOTE: The rotor set rotor counterbore side must be down against wear plate for drive link clearance and to maintain the original rotor-drive link spline contact. A rotor set without a counterbore and that was not etched before disassembly can be reinstalled using the drive link spline pattern on the rotor splines if apparent, to determine which side was down. The rotor set seal ring groove faces toward the wear plate (9).**



Figure 45

# 76-238 ASSEMBLY INSTRUCTIONS

Apply clean grease to a **new** seal ring (4) and assemble it in the seal ring groove in the rotor set contact side of manifold (7). SEE FIGURE 46.

## NOTE

**NOTE:** The manifold (7) is made up of several plates bonded together permanently to form an integral component. The manifold surface that must contact the rotor set has it's series of irregular shaped cavities on the largest circumference or circle around the inside diameter. The polished impression left on the manifold by the rotor set is another indication of which surface must contact the rotor set.

## Install manifold and seal ring

14. Assemble the manifold (7) over the drive link (10) and onto the rotor set. Be sure the correct manifold surface is against the rotor set. SEE FIGURE 47.

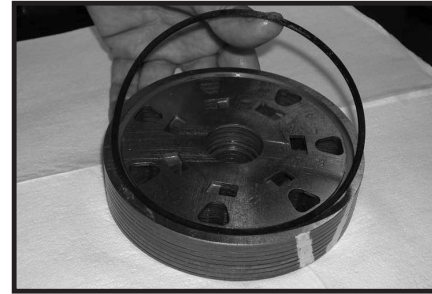

Figure 46

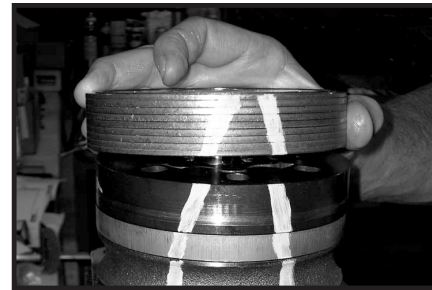

Figure 47

Apply grease to a **new** seal ring (4) and insert it in the seal ring groove exposed on the manifold. SEE FIGURE 48.



Figure 48

## Install commutator ring

15. Assemble the commutator ring (6) onto the manifold. SEE FIGURE 49.



Figure 49

## Assemble seal & commutator

16. Assemble a **new** seal ring (3) flat side up, into commutator (5) and assemble commutator over the end of drive link (10) onto manifold (7) with seal ring side up. SEE FIGURES 50 and 51.



Figure 50

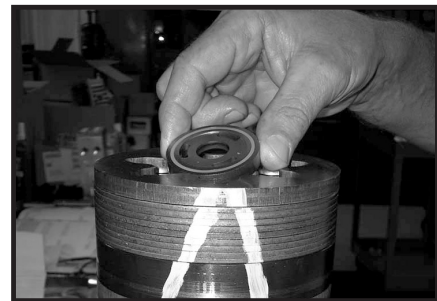

Figure 51

## Assemble shuttle valve parts into end cover

17. If shuttle valve components items #21, #22, #23, #24 were removed from the end cover (2) turn a plug (21) with a **new** o-ring (22), loosely into one end of the valve cavity in the end cover. Insert a spring (23) the valve (24) and the second spring (23) into the other end of the valve cavity. Turn the second plug (21) with a **new** o-ring (22) loosely into the end cover valve cavity. 3/16 inch Allen wrench required. SEE FIGURE 52.

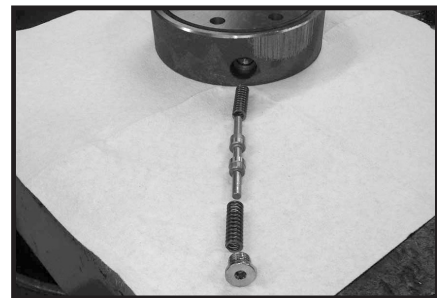

Figure 52

## Assemble relief valve parts in end cover

18. If relief valve components items #21, #22, #24 were removed from the end cover (2) assemble a **new** o-ring (22) on the two plugs (21). Assemble a two piece relief valve (24) in each of the plugs, with the large end of the conical spring into the plug first and the small nut of the other valve piece in the small end of the conical spring. Turn each of the plug and relief valve assemblies into the end cover loosely to be torqued later. 3/8 inch Allen or 1 inch Hex socket required. SEE FIGURE 53.



Figure 53



# 76-238 ASSEMBLY INSTRUCTIONS

## Assemble seal ring & end cover

19. Assemble a **new** seal ring (4) into end cover (2) and assemble end cover onto the commutator set. SEE FIGURES 54 and 55.

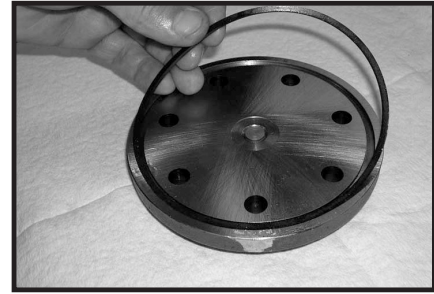

Figure 54

## NOTE

**NOTE:** If the end cover has a valve (24), use the line you previously scribed on the cover to radially align the end cover into its original position.

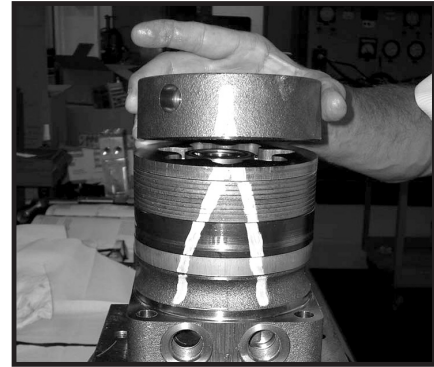

Figure 55

## Assemble cover bolts

20. Assemble the 7 special bolts (1, 1A, 1B or 1C) and screw in finger tight. Alternately and progressively tighten the bolts to pull the end cover and other components into place with a final torque of 50-55 ft. lbs. (68-75 N m) for the seven 3/8-24 threaded bolts. SEE FIGURES 56, 57 and 58.

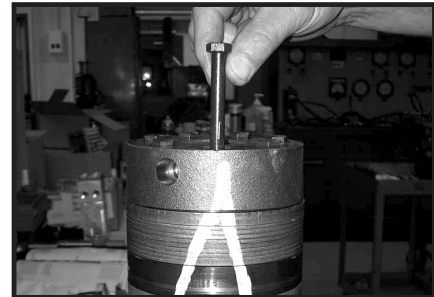

Figure 56

**NOTE**

**NOTE:** The special bolts required for use with the relief or shuttle valve (24) end cover assembly (2) are longer than the bolts required with standard and cover assembly. Refer to the individual service parts lists or parts list charts for correct service part number if replacement is required.

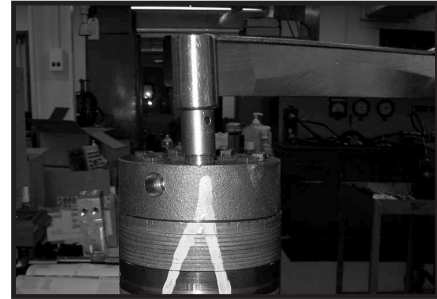

Figure 57

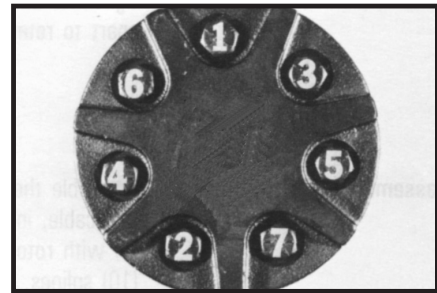

Figure 58

**Torque the valve plugs**

21. Torque the two shuttle valve plug assemblies (21) in end cover assembly to 9-12 ft. lbs. (12-16 N m) if cover is so equipped. SEE FIGURE 59.

Torque the two relief valve plug assemblies (21) in end cover assembly to 45-55 ft. lbs. (61-75 N m) if cover is so equipped.

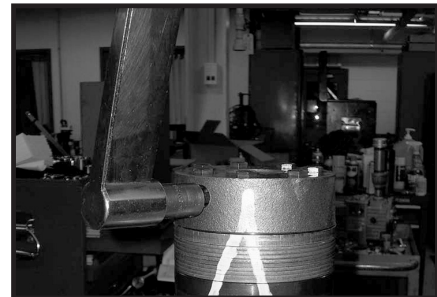

Figure 59

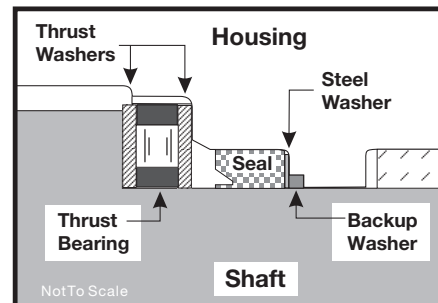

Figure 60

THE ASSEMBLY OF THE TORQMOTOR™ IS NOW COMPLETE EXCEPT FOR WOODRUFF KEY (12A), NUT (12B), WASHER (12C), BOLT (12D), LOCKWASHER (12E), RETAINER RING (12F) or PORT O-RINGS (18A) AT INSTALLATION IF APPLICABLE. PROCEED TO FINAL CHECKS SECTION.

## Final Checks

- Pressurize the Torqmotor™ with 100 p.s.i. dry air or nitrogen and submerge in solvent to check for external leaks.
- Check Torqmotor™ for rotation. Torque required to rotate coupling shaft should not be more than 50 ft. lbs. (68 N m)
- Pressure port with “B” cast under it on housing (18) is for clockwise coupling shaft rotation as viewed from the output end of coupling shaft. Pressure port with “A” case under it is for counter clockwise coupling shaft rotation.
- Use test stand if available, to check operation of the Torqmotor™.

## Hydraulic Fluid

Keep the hydraulic system filled with one of the following:

- 10W40 SE or SF manufacturers suggested oil.
- Hydraulic fluid as recommended by equipment manufacturer, but the viscosity should not drop below 50 SSU or contain less than .125% zinc anti-wear additives.

**CAUTION: Do not mix oil types. Any mixture, or an unapproved oil, could deteriorate the seals. Maintain the proper fluid level in the reservoir. When changing fluid, completely drain old oil from the system. It is suggested also that you flush the system with clean oil.**

## Filtration

Recommended filtration 40-50 micron.

## Oil Temperature

Maximum operating temperature 200°F (93.3° C).



# 76-023 3-BANK HYDRAULIC VALVE PARTS LIST

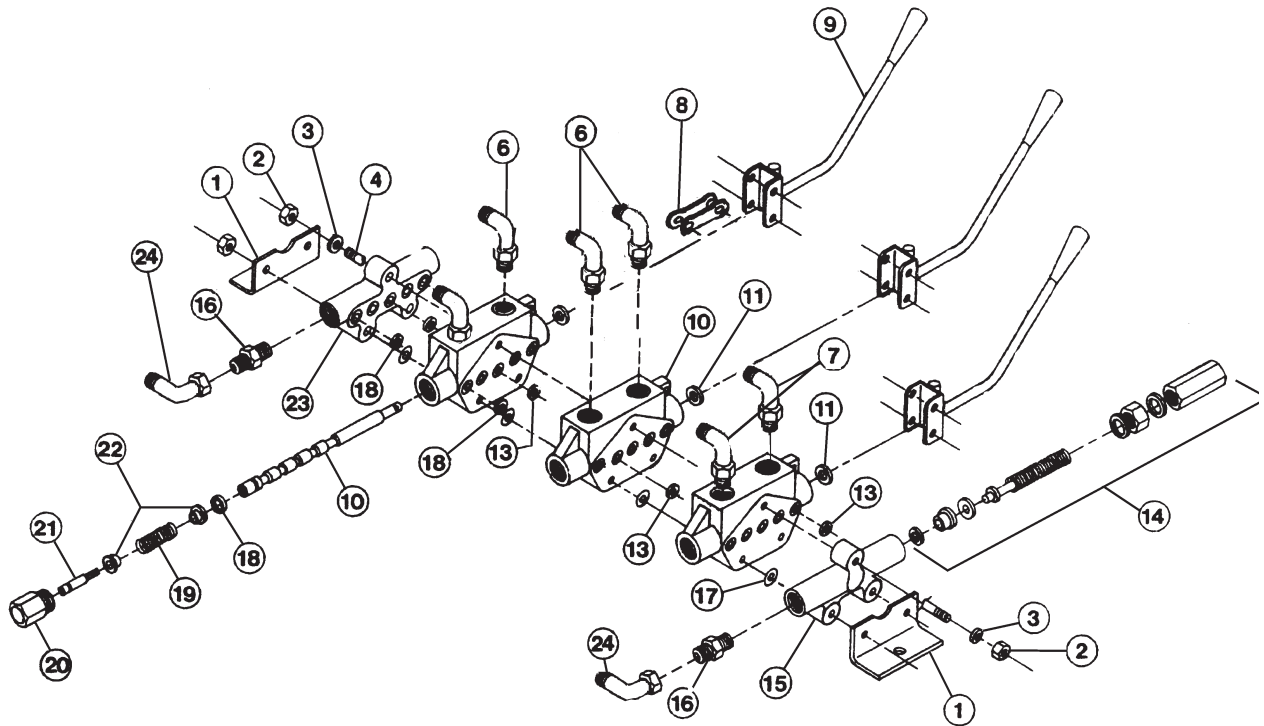

REF#	PART#	DESCRIPTION	QUANTITY
1	76-023-03	Mounting Bracket	2
2	HN-516-18	Hex Nut, $\frac{5}{16}$ - 18	6
3	HW-14	Flat Washer, $\frac{1}{4}$	2
4	76-023-06	Tie Rod	3
6	18-188	Elbow 45°	4
7	18-168	Elbow 90°	2
8		Linkage (comes with handle)	
9	76-309	Valve Handle (sold as a set of 3)	1
	76-125-01	Knob	1 per handle
10	76-023-07	Body and Spool (matching set)	3
11*		In-body O-Ring	3
13*		O-Ring	15
14	76-023-08	Inlet Kit (load check and relief, 2000 psi)	1
15		Inlet with Load Check	1
16	18-169	Adapter	2
17*		Mylar Shim	9
18*		O-Ring	3
19		Spring (type 10 spool)	3
20	76-023-01	Spring Cap	3
21	76-023-02	Spring Shaft	3
22	76-023-09	Spring Guide	6
23	76-023-10	Outlet Open Center	1
24	18-214	Elbow 45°	2

\* 14-096 O-Ring Seal Kit (includes all \* items) 1

# 76-271 DUST/DIRT FILTRATION SYSTEM

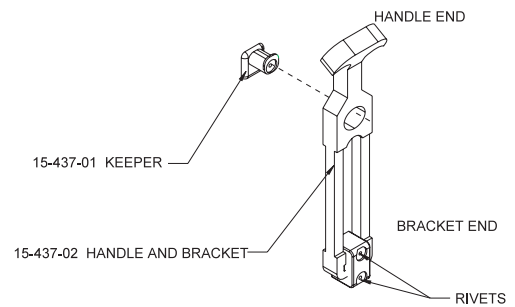
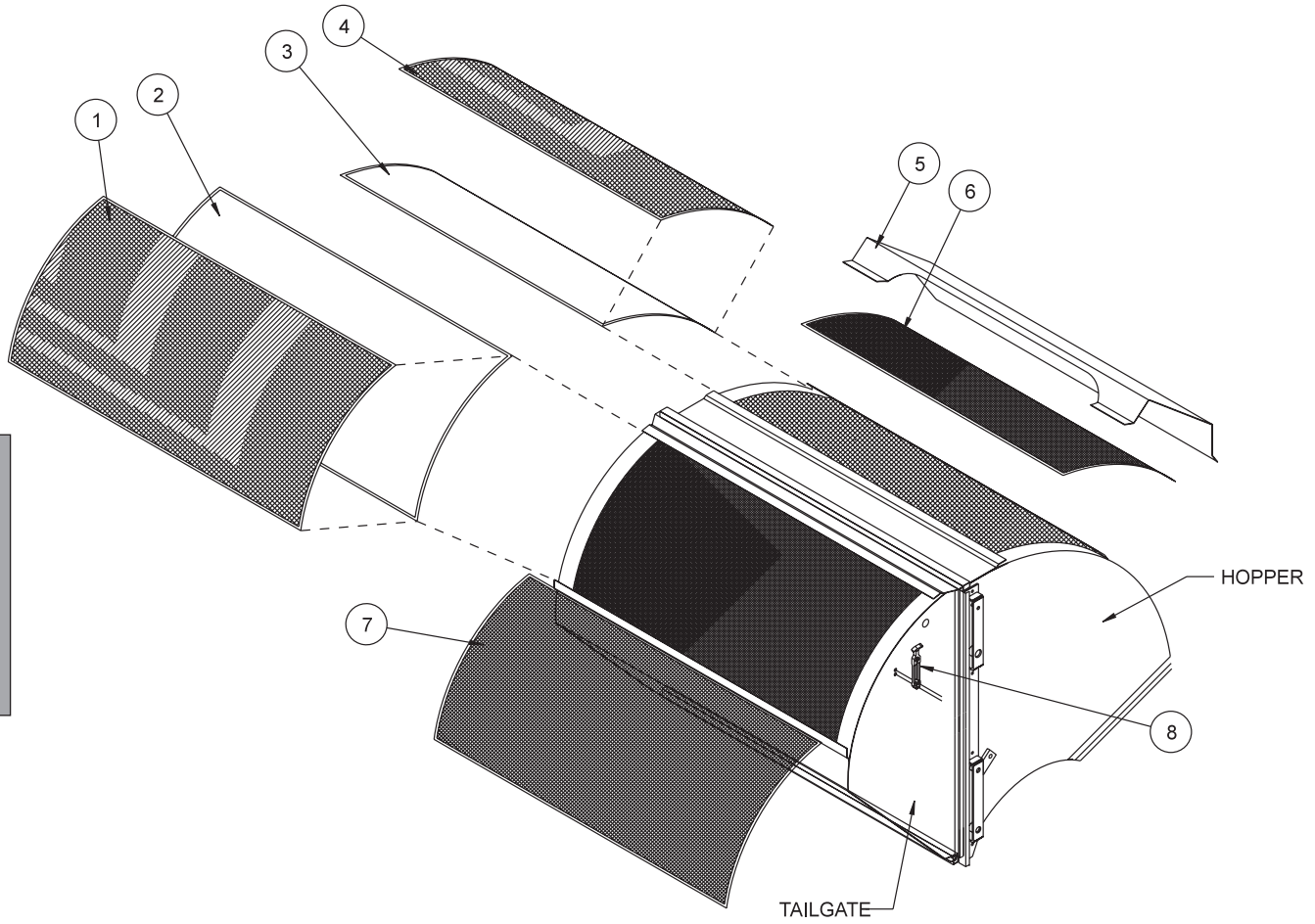

Parts

## 76-271 DUST/DIRT FILTRATION SYSTEM

REF#	PART#	DESCRIPTION	QUANTITY
1*	76-249	Tailgate Screen for Filter (28 x 58)	1
	*15-437-01	Keeper	2
	HRS-316-1125	Steel Rivet, $\frac{3}{16}$ x $1\frac{1}{8}$	2
2*	76-247	Tailgate Filter (28 x 57)	1
3*	76-246	Hopper Filter (24 x 57)	1
4*	76-248	Hopper Screen for Filter (24 x 28)	1
	*15-437-01	Keeper	2
5	76-263	Hopper Screen Cover (Serial Number 1000-1497)	1
	76-359	Hopper Screen Cover (Serial Number 1498 and Up)	1
6	76-261	Hopper Screen	1
7	76-262	Tailgate Screen	1
8	*15-437-02	Handle and Bracket	4
	HRS-316-1125	Steel Rivet, $\frac{3}{16}$ x $1\frac{1}{8}$	8
*	15-437	Latch (comes with 15-437-01 and 15-437-02)	2

## INSTALLATION INSTRUCTIONS

1. If your sweeper has a latch (Ref 8) on the tailgate screen, release the latch.
2. There is enough rubber trim to place on each short ends of the hopper and tailgate screens. This will make a tighter seal. Do this before installing screens.
3. Remove tailgate screen (Ref 7) from tailgate. Unwedge the top and lift out of the bottom tab.
4. If your machine does not have the latch, please install it using the two steel  $\frac{3}{16}$  x  $1\frac{1}{8}$  rivets we provide.
5. First, place the cloth filter (Ref 2) onto the tailgate screen, then place tailgate filter screen (Ref 1) over the top of the cloth filter by placing the screen in to the bottom tab and wedging it into the top tab. The keeper part of the latch is already riveted onto the tailgate filter screen.
6. Place the handle and bracket onto the keeper and bend over the side of the tailgate to the desired tension, mark where the two holes from the handle and bracket line up on the tailgate side panel.
7. You need to drill two  $\frac{3}{16}$  holes where your marks are, approximately centered on the curve and 1" from edge of material, on each tailgate side.
8. Release handle end from keeper and place bracket end of latch handle over holes you drilled, attach with two steel rivets.
9. Do this too both sides.
10. Remove the hopper screen cover (Ref 5) by unwedge the top and pulling it out of the bottom tab. You cannot use this cover with the filtration kit.
11. Remove the hopper screen (Ref 6) from the hopper by unwedge the top and pulling it out the bottom tab.
12. Place the cloth filter (Ref 3) onto the hopper, then place the hopper filter screen (Ref 4) over the top of the cloth filter by placing the screen in to the bottom tab and wedging it into the top tab.

# 76-488 FRENCH BRUSH REEL KIT

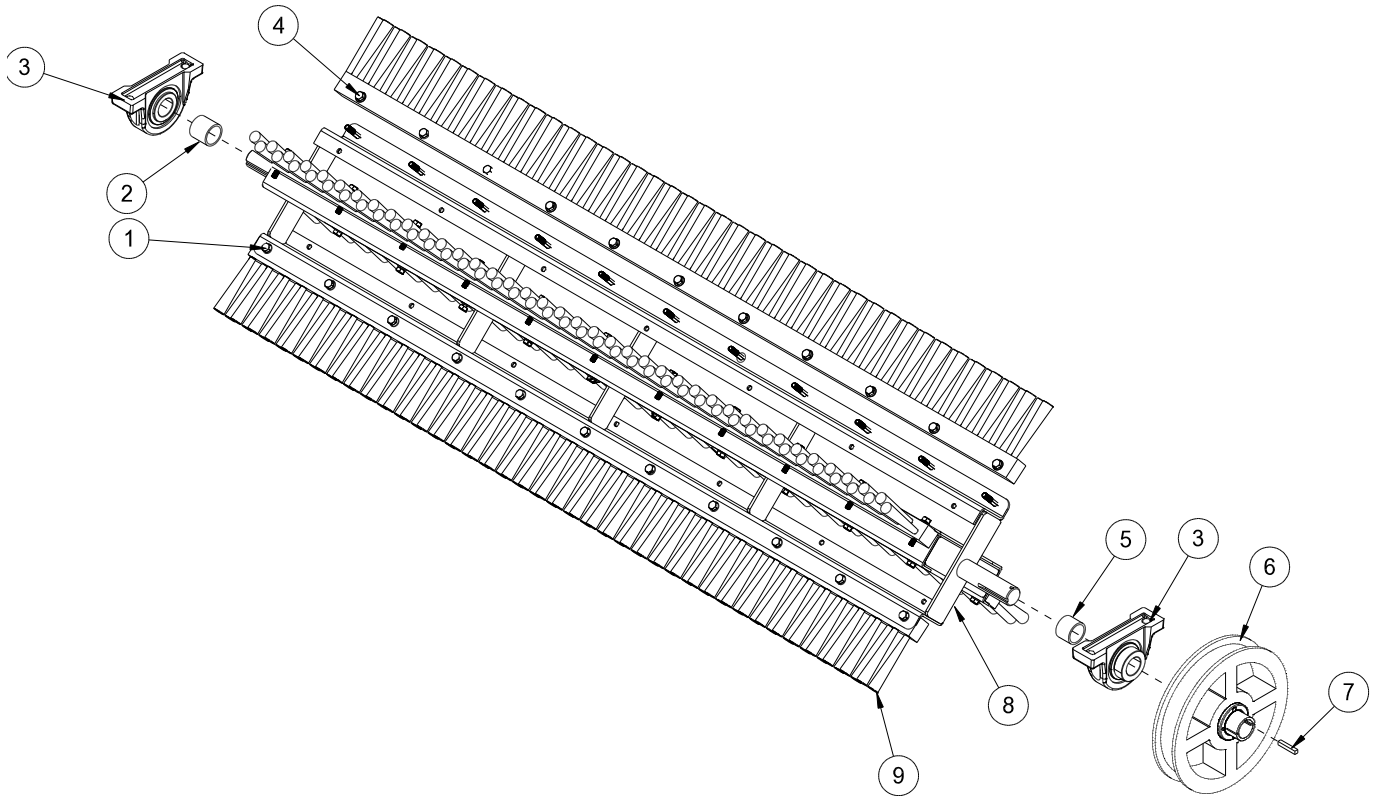

REF	PART#	DESCRIPTION	QUANTITY
1	HB-516-18-175	Bolt $\frac{5}{16}$ - 18 x $1\frac{3}{4}$	44
	HW-14	Washer $\frac{1}{4}$	44
2	75-686	Spacer	1
3	75-511	Pillow Block	2
4	HNTL-516-18	Lock Nut $\frac{5}{16}$ - 18	44
5	75-834	Spacer	1
6	76-102	Pulley with Hub	1
	76-102-01	Hub Only	
7	HKSQ-14-150	Square Key $\frac{1}{4}$ x $1\frac{1}{2}$	1
8	76-456	Brush Reel Frame	1
9	76-455	Brush	4

## DECAL LIST

This is a list of decals located on the Sweep Star 60. Part number, description and location will help in reordering decals.

16-088*	Moving Parts Hot	Belt Guard
13-690	Diesel	Side Panel (diesel only)
25-078	Caution No Riders	Engine Cover
25-277*	Alternator/Battery	Under Seat on Hopper Panel
25-286	Pinch point	On Each Side Bottom Tailgate
25-307*	Gasoline	Console Back Above Fuel Tank (gas only)
25-313*	Slope 10° Max	Nose Cone
25-320*	Load Limit	Left Hopper Front
25-321	Diesel Fuel Only	Console Back Above Fuel Tank (diesel only)
25-352	By Pass valve	Hang Tag
25-355	Tire Pressure 18 psi	Rear Wheels
25-356	Tire Pressure 20 psi	Front Wheel and Castor Wheel
25-359	Smithco	Tailgate
25-362	Danger Fire	Hopper
25-376	98 dBA	Console
27-077	Round Smithco	Steering Wheel
27-093*	Hydraulic Oil Level	Console Back Above Hydraulic Tank
30-117	Ultra Fuel	Fuel Tank (diesel only)
34-147	Smithco Star	Front Nose Cone
75-651	Hopper Lift Safety	Hopper Lift Safety Bar
76-417	Sweep Star 60	One each Side of Hopper
76-199	Control Panel	Control Panel (gas only)
76-245	Reel Height	Right Tower on Front
76-304*	Crush/Pinch	Right and Left Hopper Front
76-305*	Rotating Parts	Right and Left Sides of Grass Chute
76-306*	Attachment Clutch	Engine Cover (diesel only)
76-307*	Tower Warning	Left and Right Towers
76-315*	Belt Routing	Behind Belt Guard
77-178	Control Panel	Control Panel (diesel only)
48-136	Decal, Sweeper Set (all * items)	
76-744	Decal Set CE	

# QUICK REFERENCE REPLACEMENT PARTS

## REPLACEMENT FILTERS

23-031	Hydraulic Oil Filter	
13-531	Engine Oil filter	Briggs # 842921
76-395-01	Air Cleaner Cartridge	Briggs # 841497
76-395-02	Safety Filter Cartridge	Briggs # 821136
50-403	Fuel Filter	

## REPLACEMENT FILTERS KUBOTA ENGINE

17-255	Oil Filter Cartridge	
77-213	Air Cleaner Element (steel canister)	Kubota# 70000-11221
42-076-03	Air Cleaner Element (plastic canister)	
77-214	Fuel Filter Assembly	Kubota# 19204-43013
17-043	Fuel Filter Element	Kubota# 15231-4356-0

## REPLACEMENT BELTS

76-200	Finger Reel Belt	2/A74
77-212	Kubota Fan Belt	Kubota# 15881-97011

## SEAL KITS

76-023	3-Bank Hydraulic Valve	
14-096	O-Ring Seal Kit	
76-638	Hydrostatic Pump (Gas)	
77-239-23	Seal Repair Kit	
77-264	Hydrostatic Pump (Diesel)	
77-239-22	Seal Kit	

76-197	Gear Pump	
76-197-08	Seal Kit	

76-238	Wheel Motor	
14-080	Seal Kit	

76-627	Hydraulic Cylinder	
76-242-01	Seal Kit	

77-263	Hydraulic Cylinder	
14-530	Seal Kit	

76-478	Hydraulic Cylinder	
14-531	Seal Kit	

## FLUIDS

Engine Oil Vanguard		SJ or Higher 10W-30
Engine Oil Kubota	CC/ CD/ CE 10W-40	
Hydraulic Fluid	SJ or Higher 10W-40	
Anti-Freeze	Use permanent type mixed with water. The anti-freeze mixing ratio must be less than 50%.	

## OTHER PARTS

13-488	Key Switch	
17-068	Key Switch Kubota	
	Spark Plugs	Champion® type RC 12 YC or Equivalent Gap 0.030 (.76 mm) Torque 18/22 ft. lbs (24.4/29.8 Nm)

# The Smithco Commercial Products Two-Year Limited Warranty

Smithco, Inc. (Smithco) warrants your 2016 or newer Smithco Commercial Product ("Product") purchased after October 1, 2016 to be free from defects in materials or workmanship for the period of time listed below. Where a warrantable condition exists, Smithco will repair the Product at no cost to you including diagnosis, labor (at the Smithco standard labor rate, subject to the Smithco flat rate schedule), and parts.

## Warranty Duration is:

- (1) Two years, 1500 operational hours\* from the date of delivery to the original purchaser or Five years from the date of original manufacturer of the product, whichever occurs first. (\*Products equipped with hour meter).
- (2) Products used in rental situations are covered for 90 days from date of delivery to original user/renter.

## Owner Responsibilities:

As the Product owner, you are responsible for required maintenance and adjustments stated in your Owner's Manual. Failure to perform required maintenance and adjustments can be grounds for disallowing a warranty claim. **You are particularly responsible to train all present and future operators of this product on the safe operation of this product at your location.**

## Instructions for Obtaining Warranty Service:

You are responsible for notifying the Authorized Smithco Products Distributor from whom you purchased the Product as soon as you believe a warrantable condition exists and not later than 30 days from discovery of the condition.

If you need help locating an Authorized Smithco Distributor, or if you have questions regarding your warranty rights or responsibilities, you may contact us at:

Smithco Product Support Department  
200 West Poplar Ave.  
Cameron, Wisconsin 54822  
Telephone: 800-891-9435 E-Mail: [ProductSupport@Smithco.com](mailto:ProductSupport@Smithco.com)

## Maintenance Parts:

Parts scheduled for replacement as required maintenance ("Maintenance Parts"), are warranted for the period of time up to the scheduled replacement time for that part.

## Items/Conditions Not Covered:

Not all product failures or malfunctions that occur during the warranty period are defects in materials or workmanship. The items/conditions listed below are not covered by this warranty:



Product failures which result from the use of non-Smithco replacement parts, or from installation and use of add-on, modified, or unapproved accessories are not covered.



Product failures which result from failure to perform required maintenance and/or adjustments are not covered.



Product failures that result from operating the Product in an abusive, negligent or reckless manner are not covered.



This warranty does not apply to parts subject to consumption through use, unless found to be defective. Examples of parts which are consumed, or used up, during normal Product operation include, but are not limited to: blades, tines, teeth, scarifiers, rakes, plates, wear plates, castor wheels, tires, batteries, filters, belts, nozzles, etc.



This warranty does not apply to failures caused by outside influence. Items considered to be outside influence include, but are not limited to, weather, storage practices, contamination, use of unapproved coolants, lubricants, additives, or chemicals, etc.



This warranty does not apply to normal “wear and tear” items. Normal “Wear and Tear” includes, but is not limited to, damage to seats due to wear or abrasion, worn painted surfaces, scratched decals or windows, etc.



Smithco may require the return of failed parts or components in order to determine the validity of any warranty claim.



Smithco will not be obligated to replace components of other manufacturers if inspection by the original component manufacturer indicates that failure was due to normal wear and tear, expected consumption through use or improper care or service.

#### **Other Legal Disclaimers:**

The above remedy for product defects through repair or replacement by an authorized Smithco distributor or dealer is the purchaser’s sole remedy for any defect. This warranty gives you specific legal rights, and you may also have other rights which vary from state to state.

**THERE ARE NO OTHER EXPRESS WARRANTIES OTHER THAN THOSE SET FORTH ABOVE. ALL IMPLIED WARRANTIES OF MERCHANTABILITY AND FITNESS FOR USE ARE LIMITED TO THE DURATION OF THE LIMITED WARRANTIES CONTAINED HEREIN.**

Some states may not allow limitations on how long an implied warranty lasts, so the above limitation may not apply to you.

**THE SMITHCO COMPANY IS NOT LIABLE FOR INDIRECT, INCIDENTAL OR CONSEQUENTIAL DAMAGES IN CONNECTION WITH THE USE OF THE PRODUCT, INCLUDING ANY COST OR EXPENSE OF PROVIDING A SUBSTITUTE PRODUCT OR SERVICE DURING PERIODS OF MALFUNCTION OR NON-USE.**

Some states may not allow the exclusion of indirect, incidental or consequential damages, so the above exclusion may not apply to you.

**Smithco neither assumes, nor authorizes any person to assume for it, any other liability in connection with the sale or use of this product.**

