

Parts & Service



SweepStar 60

76-750-A
SN: 60Q1081

June 2025

Product Support:

Hwy 55 & Poplar Ave; Cameron WI 54822
1-800-891-9435 productsupport@smithco.com

CONTENTS

Introduction

Introduction	1-3
Safe Practices	2
Specifications	3
Optional Equipment	3

Service

Service	4-9
Maintenance	4-6
Service Chart	7-8
Adjustments	9
Storage	9

Diagrams

Diagrams	10-13
Wiring Diagram	10-11
Hydraulic Diagram	12-13

Parts

Parts	14-51
Nose Cone	14
Steering Cylinder	15
Front Axle	16-17
Seat	18-19
Foot Pedal Linkage	20-21
Dash Panel	22-23
Oil Cooler and ROPs	24-25
Gas Tank and Manifold	26-27
Oil Tank	28-29
Engine and Exhaust	30-31
Reel Belt Drive	32-33
Rear Axle	34-35
Finger/Brush Reel	36-37
Hopper Lift Cylinder	38
Reel Lift Cylinder	39
Hopper	40-43
Tailgate	44
Tailgate Cylinder	45
76-638 Eaton Hydrostatic Pump	46-47
76-539 Reel Motor	48
76-559 Power Steering Pump	50-51

Accessories

Accessories	52-54
76-751 Dust/Dirt Filtration Pack	52-53
76-754 French Brush Reel	54

Reference

Reference	55-56
Decal List	55
Quick Reference Replacement Parts	56

Thank you for purchasing a **Smithco** product.

Read this manual and all other manuals pertaining to the Sweep Star carefully as they contain safety, operating, assembly and maintenance instructions. Failure to do so could result in personal injury or equipment damage.

Keep manuals in a safe place after operator and maintenance personnel have read them. Right and left sides are from the operator's seat, facing forward.

WARNING

Failure to follow cautious operating practices can result in serious injury to the operator or other persons. The owner must understand these instructions, and must allow only trained persons who understand these instructions to operate this vehicle.

All **Smithco** machines have a Serial Number and Model Number. Both numbers are needed when ordering parts. The serial number plate on the Sweep Star 60 is located on the right main frame below oil tank. Refer to engine manual for placement of engine serial number.

For product and accessory information, help finding a dealer, or to register your product please contact us at www.Smithco.com.

Information needed when ordering replacement parts:

1. Model Number of machine
2. Serial Number of machine
3. Name and Part Number of part
4. Quantity of parts

For easy access record your Serial and Model numbers here.

Model Number: _____

Serial Number: _____

Date of Purchase: _____

SMITHCO CUSTOMER SERVICE 1-800-891-9435 SMITHCO CUSTOMER SERVICE 1-800-891-9435



SAFE PRACTICES

1. It is your responsibility to read this manual and all publications associated with this machine (engine, accessories and attachments).
2. Never allow anyone to operate or service the machine or its attachments without proper training and instructions. Never allow minors to operate any equipment.
3. Learn the proper use of the machine, the location and purpose of all the controls and gauges before you operate the equipment. Working with unfamiliar equipment can lead to accidents.
4. Wear all the necessary protective clothing and personal safety devices to protect your head, eyes, ears, hands and feet. Operate the machine only in daylight or in good artificial light.
5. Inspect the area where the equipment will be used. Beware of overhead obstructions and underground obstacles. Stay alert for hidden hazards.
6. Never operate equipment that is not in perfect working order or without decals, guards, shields, or other protective devices in place.
7. Never disconnect or bypass any switch.
8. Carbon monoxide in the exhaust fumes can be fatal when inhaled, never operate a machine without proper ventilation.
9. Fuel is highly flammable, handle with care.
10. Keep engine clean. Allow the engine to cool before storing and always remove the ignition key.
11. After engine has started, machine must not move. If movement is evident, the neutral mechanism is not adjusted correctly. Shut engine off and readjust so the machine does not move when in neutral position.
13. Never use your hands to search for oil leaks. Hydraulic fluid under pressure can penetrate the skin and cause serious injury.
14. This machine demands your attention. To prevent loss of control or tipping of the vehicle:
 - A. Use extra caution in backing up the vehicle. Ensure area is clear.
 - B. Do not operate on a slope greater than 10°. Pay careful attention to the inclinometer on you machine.
 - C. Do not stop or start suddenly on sloped surfaces.
 - D. Reduce speed on slopes and in all turns. Use caution when changing directions on all surfaces.
 - E. Do not change directions of travel on any slope.
 - F. Do not operate debris hopper lift or tailgate while on slopes.
 - G. Stay alert for holes in the terrain and other hidden hazards.
15. Before leaving operator's position for any reason:
 - A. Disengage all drives.
 - B. Lower all attachments to the ground.
 - C. Set park brake.
 - D. Shut engine off and remove the ignition key.
16. Keep hands, feet and clothing away from moving parts. Wait for all movement to stop before you clean, adjust or service the machine.
17. Keep the area of operation clear of all bystanders.
18. Never carry passengers.
19. Stop engine before making repairs/adjustments or checking/adding oil to the crankcase.
20. Use parts and materials supplied by SMITHCO only. Do not modify any function or part.
21. Do not remove the radiator cap when the engine is hot. When cooled, loosen cap slightly to the stop to relieve any pressure before removing the cap completely.

These machines are intended for operation by well trained persons performing professional maintenance on golf courses, sports turf, and any other area maintained turf and related trails, paths and lots. No guaranty as to the suitability for any task is expressed or implied.

SPECIFICATIONS FOR SWEEP STAR 60

WEIGHTS AND DIMENSIONS

Length	134" (340 cm)
Width	74.5" (179 cm)
Height with Hopper Down	82" (208 cm)
Height with Hopper Up	124" (315 cm)
Wheel Base	72" (183 cm)
Weight	2550 lbs (1157 kg)

ROLL OVER PROTECTION BAR WITH SEAT BELTS

Smithco Engineered Operator Structure with Seat Belts

SOUND LEVEL

At ear level	86 dB
At 3 ft (0.914 m)	88 dB
At 30 ft (9.14 m)	76 dB

ENGINE

Make	Briggs & Stratton
Model#	613477
Type / Spec#	4246-J1
Horsepower	35 Hp (26 kw)
Fuel	Unleaded 87 Octane Gasoline Minimum
Cooling System	Air Cooled
Lubrication System	Full Pressure
Alternator	24 Amp

Tire & Wheels

Front: Two 20 x 10.00 x 10 Turf-trac (18 psi; 1.3 bar)
Rear: Two 24 x 13.00 x 12 Super Soft (18 psi; 1.3 bar)
Castor: 9 x 3.5 - 4 (20 psi; 1.4 bar)

SPEED

Forward Speed	0 to 12 m.p.h. (0-19 kph)
Reverse Speed	0 to 4 m.p.h. (0-6 kph)

BATTERY

	Automotive type 24F -12 volt
BCI Group	Size 24F
Cold Cranking Amps	4600minimum
Ground Terminal Polarity	Negative (-)
Maximum Length	10.25" (26 cm)
Maximum Width	6.88" (17 cm)
Maximum Height	10.00" (25 cm)

FLUID CAPACITY

Crankcase Oil	See Engine Manual
Fuel	8 gallon (30,2 liters)
Hydraulic Fluid	25 gallon (94,6 liters)
Grade of Hydraulic Fluid	SAE 10W-40 API Service SJ or higher Motor Oil

OPTIONAL EQUIPMENT

76-753	60" Finger Reel Kit
76-752	60" Brush Reel Kit
76-751	Filtration Pack
76-754	France Brush Reel Kit
76-744	Decal Set For CE Certification

MAINTENANCE

LUBRICATION

Use No. 2 General Purpose Lithium Base Grease and lubricate every 100 hours. The Sweep Star 60 has 16 grease fittings.

- A. One on front steering cylinder.
- B. One on each front steering pivot.
- C. One on each end of steering tie rod.
- D. One on forward pedal.
- E. One on reverse pedal.
- F. One on hydrostatic forward and reverse relay.
- G. One on each castor wheel mount bracket.
- H. One on each pillow block bearing on end of finger reel.
- I. One on the outside of each tower.
- J. One on the center of park brake relay on rear axle.
- K. One on rod end of the tailgate cylinder.

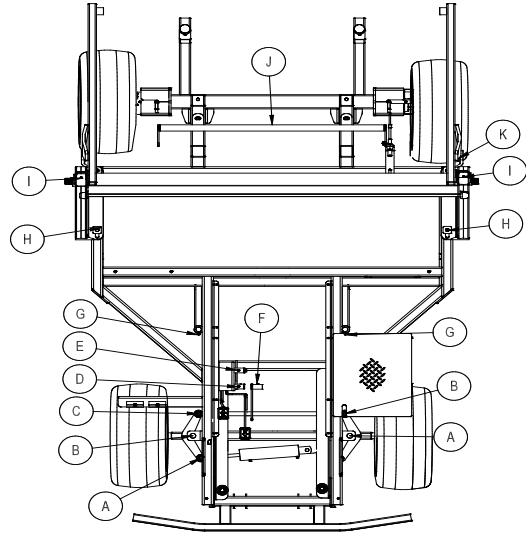

Every 500 hours of operation, separate the hydrostatic pump from the engine. Clean the splined areas and lightly grease the male portion of the pump spline. Use either Dow Corning® G-N Metal Assembly Paste or #77 Assembly Paste.

As you remount the pump to the engine, be certain the mating surface are clean and free of any foreign material and that the pump is correctly aligned.

ELECTRICAL CONNECTIONS

Use dielectric grease on all electrical connections.

AIR CLEANER ON ENGINE

1. Unclip the two clips, remove the cover and pull out the element.
2. To service, clean by tapping gently on flat surface. Do not oil. Replace if very dirty or damaged.
3. Clean out the inside of the body and cover.
4. Place the element into the body and put the cover back on..

IMPORTANT

Do not use petroleum solvents, e.g., kerosene, which will cause cartridge to deteriorate. Do not use pressurized air to clean cartridge. Pressurized air can damage cartridge.

Cyclonic air cleaner
76-395-04

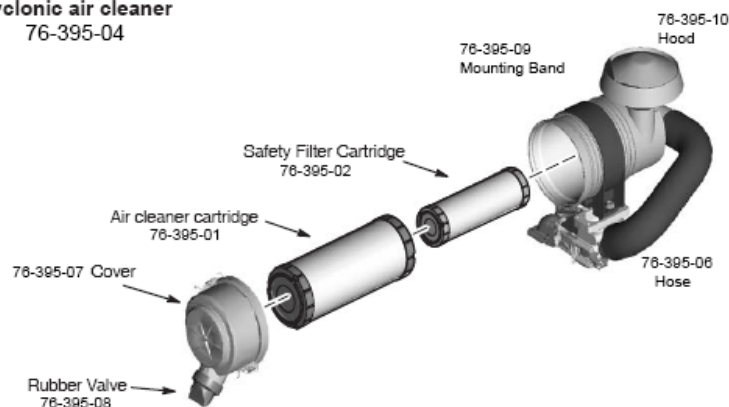

ENGINE OIL

Change and add oil according to chart below based on air temperature at the time of operation. Do not overfill. Use a high-quality detergent oil classified for service SF, SG, SH, SJ or higher. Use no special additives with recommended oils. Do not mix oil with gasoline.

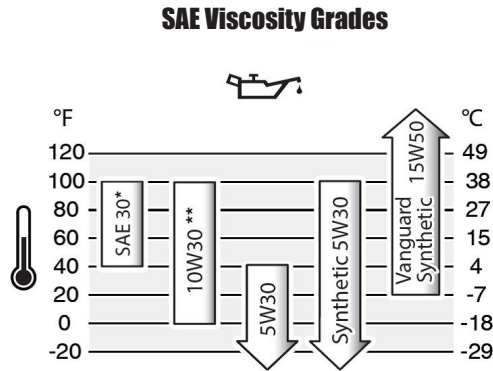

Starting Temperature Range Anticipated Before Next Oil Change

HYDRAULIC OIL

1. Use SAE 10W-40 API Service SJ or higher motor oil.
2. For proper warranty, change oil every 500 hours or annually, which ever is first and change the filter after the first 50 hours, then every 250 hours thereafter.
3. The oil level should be 2" to 2½" from top of the tank when fluid is cold. Do not overfill.
4. After changing oil and/or filter, run the machine for a few minutes. Check oil level and for leaks.
5. Always use caution when filling hydraulic oil tank or checking level to keep system free of contaminants. Check and service more frequently when operating in extremely cold, hot or dusty conditions.
6. If natural color of fluid is now black or smells burnt, it is possible that an overheating problem exists.
7. If fluid becomes milky, water contamination may be a problem.
8. If either of the above conditions happen, change oil and filter immediately after fluid is cool and find cause. Take fluid level readings when system is cold.
9. In extreme temperatures you can use straight weight oil. We recommend SAE 30W API Service SJ or higher when hot (above 90°F (33°C)) and SAE 10W API Service SJ or higher when cold (below 32°F (0°C)) ambient temperature. Use either motor oil or hydraulic oil, but do not mix.
10. Oil being added to the system must be the same as what is already in the tank. Mark tank fill area as to which type you put in.

TOWING

When it is necessary to move the Sweep Star 60 without engine running, the bypass valve built into hydrostatic pump must be "open" by turning it counterclockwise. The valve is located on bottom left of pump. An "open" valve allows fluid to pass through the wheels freely. When normal, driven, operation is desired, valve should be closed by turning it clockwise. Failure to "close" the valve with engine running means no power to wheels.

TIRE PRESSURE

Caution must be used when inflating a low tire to recommended pressure. Over inflating can cause tires to explode. Front tires should be 5 psi (.34 bar), rear tires and castor wheel should be 20 psi (1.4 bar) maximum. Improper inflation will reduce tire life considerably.

⚠ CAUTION

MAINTENANCE (CONTINUED)

WHEEL MOUNTING PROCEDURE

1. Set park brake. Turn machine off and remove key.
2. Block wheel on opposite corner
3. Loosen nuts slightly on wheel to be removed.
4. Jack up machine being careful not to damage underside of machine.
5. Remove nuts, remove wheel.
6. Place new wheel on hub lining up Hex Bolt holes.
7. Torque nuts to 64-74 ft/lb (87-100 Nm) using a cross pattern. Torque again after first 8 hours and every 200 hours thereafter.
8. Lower machine to ground and remove blocks and jack.

BATTERY

Batteries normally produce explosive gases which can cause personal injury. Do not allow flames, sparks or any ignited object to come near the battery. When charging or working near battery, always shield your eyes and always provide proper ventilation.

Battery cable should be disconnected before using "Fast Charge".

Charge battery at 15 amps for 10 minutes or 7 amps for 30 minutes. Do not exceed the recommended charging rate. If electrolyte starts boiling over, decrease charging.

Always remove grounded (-) battery clamp first and replace it last. Avoid hazards by:

1. Filling batteries in well-ventilated areas.
2. Wear eye protection and rubber gloves.
3. Avoid breathing fumes when electrolyte is added.
4. Avoid spilling or dripping electrolyte.

⚠ WARNING

Battery Electrolyte is an acidic solution and should be handled with care. If electrolyte is splashed on any part of your body, flush all contact areas immediately with liberal amounts of water. Get medical attention immediately.

⚠ WARNING

Use of booster battery and jumper cables. Particular care should be used when connecting a booster battery. Use proper polarity in order to prevent sparks.

JUMP STARTING

To jump start (negative grounded battery):

1. Shield eyes.
2. Connect ends of one cable to positive (+) terminals of each battery, first (A) then (B).
3. Connect one end of other cable to negative (-) terminal of "good" battery (C).
4. Connect other end of cable (D) to engine block on unit being started (NOT to negative (-) terminal of battery)

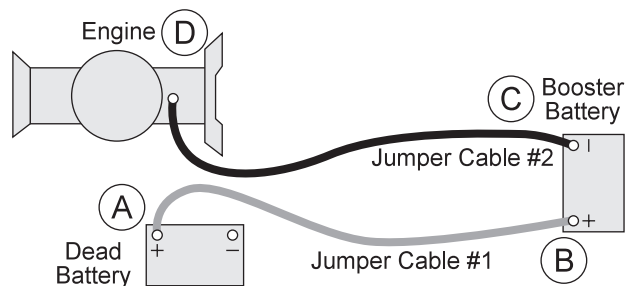

To prevent damage to other electrical components on unit being started, make certain that engine is at idle speed before disconnecting jumper cables.

SERVICE CHART

⚠ CAUTION

Before servicing or making adjustments to the machine, stop engine, set park break, block wheels and remove key from ignition.

⚠ IMPORTANT

Follow all procedures and **ONLY** use parts prescribed by the manufacturer. Read the engine manual before maintenance.

The suggested maintenance checklist is not offered as a replacement for the manufacturer's engine manual but as a supplement. You must adhere to the guidelines established by the manufacturer for warranty coverage. In adverse conditions such as dirt, mud or extreme temperatures, maintenance should be more frequent.

Service

Maintenance Service Interval	Maintenance Procedure
After the first 8 operating hours	Torque the wheel lug nuts. (64-74 ft/lb (87-100 Nm))
	Change the engine oil filter.
Before each use daily	Check the engine oil level.
	Clean area around muffler and controls.
	Check the hydraulic fluid level.
	Check the tire pressure.
	Check and clean Debris Filter Pack1
	Check condition of hydraulic hoses and fittings.
	Inspect and clean the machine.
After the first 50 hours	Change Hydraulic Oil Filter.
Every 100 hours	Clean or change air filter.1&2
	Clean pre-cleaner.1
	Change engine oil and filter.
	Replace spark plug .
	Lubricate machine.
	Clean or change remote air cleaner.
	Check the battery fluid level and cable connections..
	Service exhaust system.
Check belt tension .	
Every 250 hours	Check engine valve clearance and adjust if necessary.
	Check idle speed.
	Clean battery terminals.
	Change hydraulic oil filter.
	Torque the wheel lug nuts. (64-74 ft/lb (87-100 Nm))
Every 500 hours or yearly	Change fuel filter.
	Change hydraulic oil and filter.
	Clean oil cooler fins.1
	Replace air filter2
	Replace fuel filter
	Clean air cooling system.1
Check safety filter in remote air cleaner.	

1 In dusty conditions or when airborne debris is present, clean more often.

2 Every third air filter change, replace the inner safety filter.

SWEEPING

While sweeping close tailgate frequently to ensure tailgate does not creep open.

While operating the Sweep Star's sweeper head, it is important to disengage the head before raising. If the sweeper head is raised while it is engaged, it can cause the belt to slip off the pulleys. This can result in belt failure and engine crankshaft failure. To ensure a long life of your sweeper,

CAUTION

Disengage the sweeper head before raising.

FILTER PACK

Filter pack may be cleaned by shaking or spraying off with low pressure water. Filter will disintegrate if high pressure is used on it.

PARK BRAKE ADJUSTMENT

By turning knob on end of park brake lever you can tighten or loosen brake a small amount. To tighten turn the knob clockwise. To loosen turn counter clockwise. If this is not enough turn clevis on brake cable to adjust length of cable.

WHEEL 'CREEP' ADJUSTMENT

'Creep' is when engine is running and hydrostatic transmission is in neutral, but due to inadequate alignment, wheels still move. Do the following procedures to stop this motion.

1. Lift up and support the unit so rear wheels are off the ground and can turn freely.
2. On the side of hydrostatic transmission is the shift arm (A). In the 'V' shaped notch of shift arm rests and idler pulley (B). This pulley is mounted on an idler arm (C).
3. Loosen Hex Bolt and nut holding pulley to idler arm. Leave finger tight.
4. With engine running, slide the pulley in idler arm slot until it centers on shift arm on hydrostatic and wheel 'creep' stops.
5. Tighten all fasteners and test by using foot pedal linkage to see that the 'creep' is removed.
6. Turn the engine off and lower the machine.

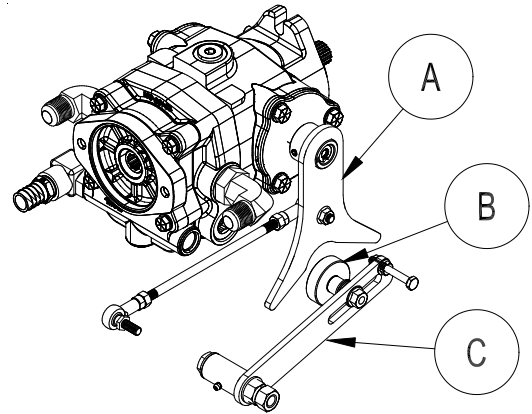

STORAGE

When storing, remove the key from the key switch to avoid unauthorized persons from operating machine.

1. Before storing clean machine thoroughly.
2. Check Hex Bolts and nuts, tighten as necessary.
3. Make all repairs that are needed and remove any debris.
4. Remove the battery, adjust the electrolyte level and recharge it. Store the battery in a dry, dark place.
5. Store in a clean and dry area, but NOT near a stove, furnace or water heater which uses a pilot light or any device that can create a spark.
6. Engines stored over 30 days need to be protected or drained of fuel to prevent gum from forming in a fuel system or on essential carburetor parts. Check the engine manual and follow the instructions for the storage of the engine.

WIRING PARTS LIST

REF#	PART#	DESCRIPTION	QUANTITY
1	76-544	Cooler Fan	1
2	50-359	Warning Indicator Light	1
3	13-488	Key Switch with Hardware	1
4	12-804	Hour Meter	1
5	8935	Buss Bar - Negative	1
6	8935	Buss Bar - Positive	1
7	15-728	Centering Switch, On-Off-On	3
	15-727	Rocker, No light	3
	15-729	Mount Panel, Middle	1
	15-725	Mount Panel, End	2
8	76-560	Manifold	1
9	15-782	Unlit Switch, On-None-Off	2
	15-727	Rocker, No light	2
	15-725	Mount Panel, End	2
10	32-014	Headlights	2
11	76-563	Wire Harness	1
12	77-261	Circuit Breaker 40 AMP	1
	8977	Circuit Breaker Boot	1
13	76-749	Briggs 35hp Engine	1
	76-446-02	Oil Sender	1
14		Starter Solenoid (Part of Engine)	
15		Starter (Part of Engine)	
16	48-157	Red Battery Cable	1
17*	76-757	Electric Fuel Pump w/ Connectors	1
18*	9016	2-Contact Tower	1
	9017	Weather Pack Terminal	2
	9018	Seal	2
19	76-633	Fuel Pump Wire Harness	1
20	30-042-06	Relay	1
21	33-216	Battery	1
22	48-268	Black Battery Cable	1
23	45-529-01	Seat Switch	1
	76-563	Main Wire Harness	1
	76-633	Fuel Pump Wire Harness	1

HYDRAULIC DIAGRAM

Diagrams

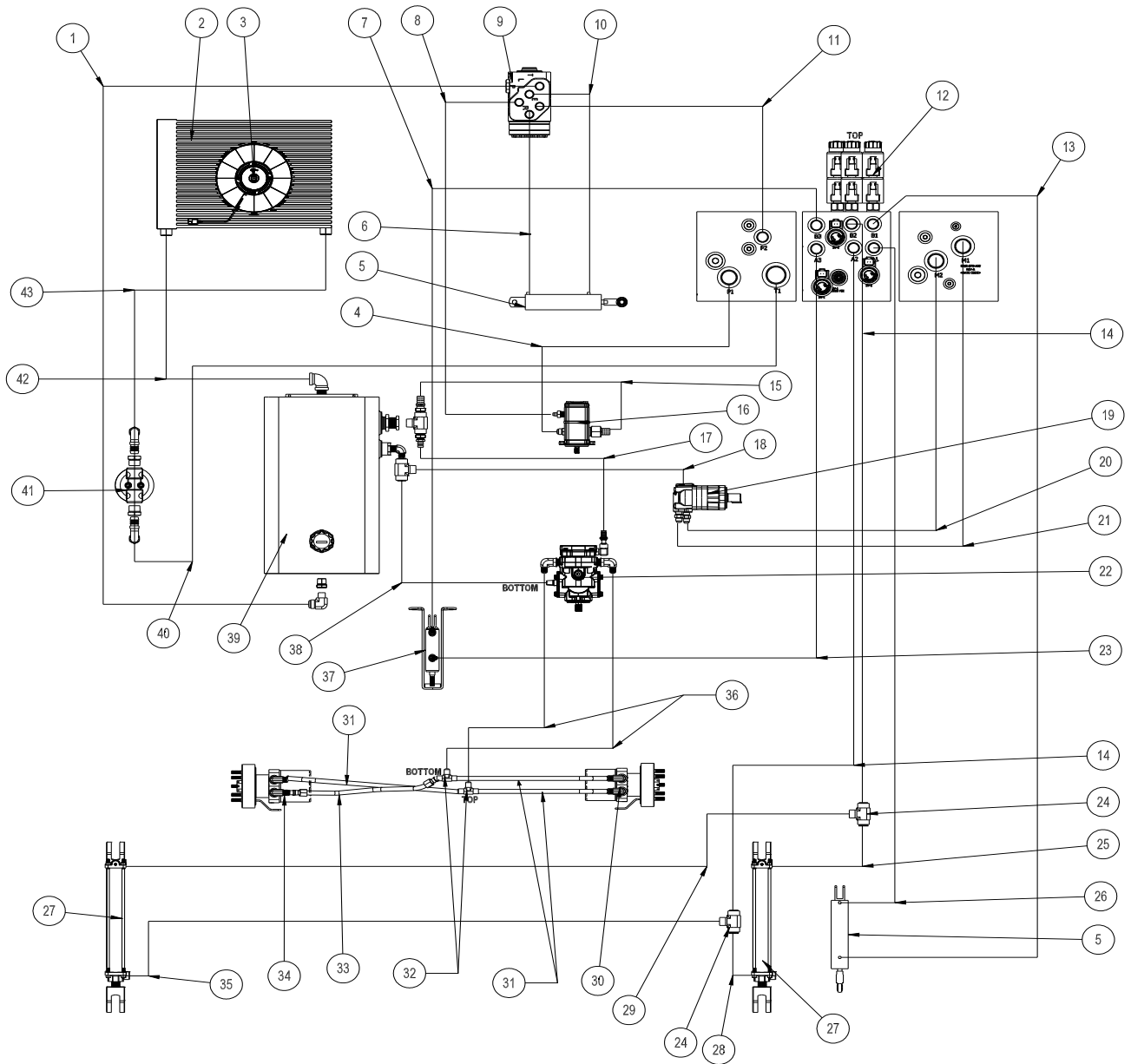

HYDRAULIC DIAGRAM PARTS LIST

REF#	PART#	DESCRIPTION	QUANTITY
1	76-532	STC Hydraulic Hose, 83"	1
2	76-561	Cooler	1
3	76-544	Cooler Fan	1
4	76-556	Hydraulic Hose, 45"	1
5	15-839	Hydraulic Cylinder (Steering & Tailgate)	2
6	76-534	STC Hydraulic Hose, 55"	1
7	76-551	Hydraulic Hose, 33"	1
8	76-535	STC Hydraulic Hose, 65"	1
9	76-559	Orbitrol	1
10	76-533	STC Hydraulic Hose, 53"	1
11	76-531	STC Hydraulic Hose, 106"	1
12	76-560	Manifold	1
13	76-557	Hydraulic Hose, 191"	1
14	76-549	Hydraulic Hose, 91"	2
15	8833	1" Suction Hose	50"
	18-222	Hose Clamp	2
16	76-540	Gear Pump	1
17	8832	³ / ₄ " Suction Hose	41"
	18-040	Hose Clamp	2
18	76-547	Hydraulic Hose, 50"	1
19	76-539	Reel Motor	1
20	76-553	Hydraulic Hose, 48"	1
21	76-554	Hydraulic Hose, 53"	1
22	76-638	Hydrostat Pump	1
23	76-552	Hydraulic Hose, 33"	1
24	18-173	Tee ³ / ₈ " Junction Union	2
25	76-116	Hydraulic Hose, 6.5"	1
26	76-548	Hydraulic Hose, 182"	1
27	76-627	Hydraulic Cylinder (Hopper)	2
28	76-117	Hydraulic Hose, 20"	1
29	76-114	Hydraulic Hose, 72"	1
30	76-543	RH Wheel Motor	1
31	20-656	Hydraulic Tube Assembly	3
32	34-057	Tee	2
33	76-541	Hydraulic Tube Assembly	1
34	76-542	LH Wheel Motor	1
35	76-115	Hydraulic Hose, 84"	1
36	76-555	Hydraulic Hose, 116"	2
37	76-478	Hydraulic Cylinder (Reel Lift)	1
38	76-550	Hydraulic Hose, 35"	1
39	76-545	Oil Tank	1
	13-586-03	Filler Neck	1
	13-747	Filler Breather	1
40	8833	1" Suction Hose	52"
	18-222	Hose Clamp	2
41	72-146	Oil Filter Assembly	1
	60-334	Filter Element (replacement only)	1
42	8833	1" Suction Hose	10.5"
	18-222	Hose Clamp	2
43	8833	1" Suction Hose	33"
	18-222	Hose Clamp	2

NOSE CONE DRAWING

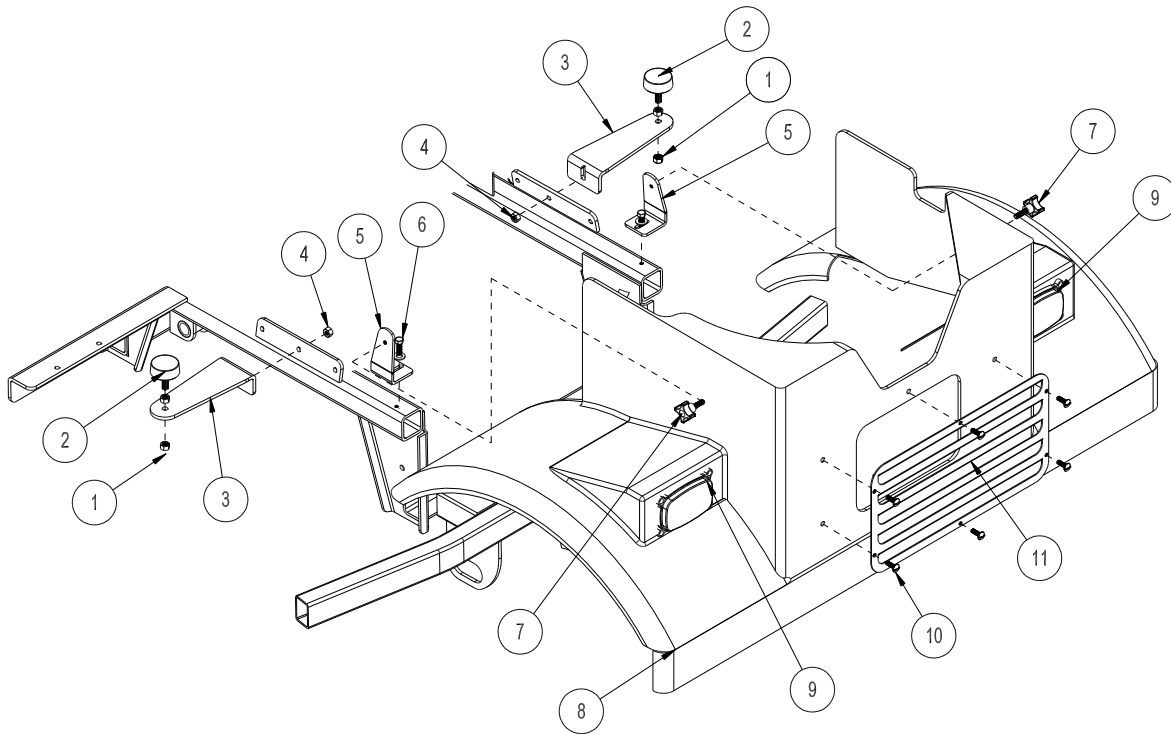

Parts

REF#	PART#	DESCRIPTION	QUANTITY
1	50-081	Rubber Insulator	2
2	HNFL-38-16	Flange Whiz-loc Nut, $\frac{3}{8}$ - 16	4
3	76-584	Glass Support	2
4	HB-516-18-100	Hex Bolt, $\frac{5}{16}$ - 18 x 1	2
	HNFL-516-18	Flange Whiz-loc Nut, $\frac{5}{16}$ - 18	2
5	76-583	Front Glass Support	2
6	HB-38-16-125	Hex Bolt, $\frac{3}{8}$ - 16 x $1\frac{1}{4}$	2
	HWL-38	Lock Washer, $\frac{3}{8}$	2
7	42-462	Plastic Knob	2
8	76-562	Nose Cone	1
9	32-014	Headlight	2
10	HSTP-14-20-075	Truss Head Screw, $\frac{1}{4}$ - 20 x $\frac{3}{4}$	6
	HNFL-1/4-20	Flange Whiz-loc Nut, $\frac{1}{4}$ - 20	6
11	76-597	Louver	1

STEERING CYLINDER DRAWING

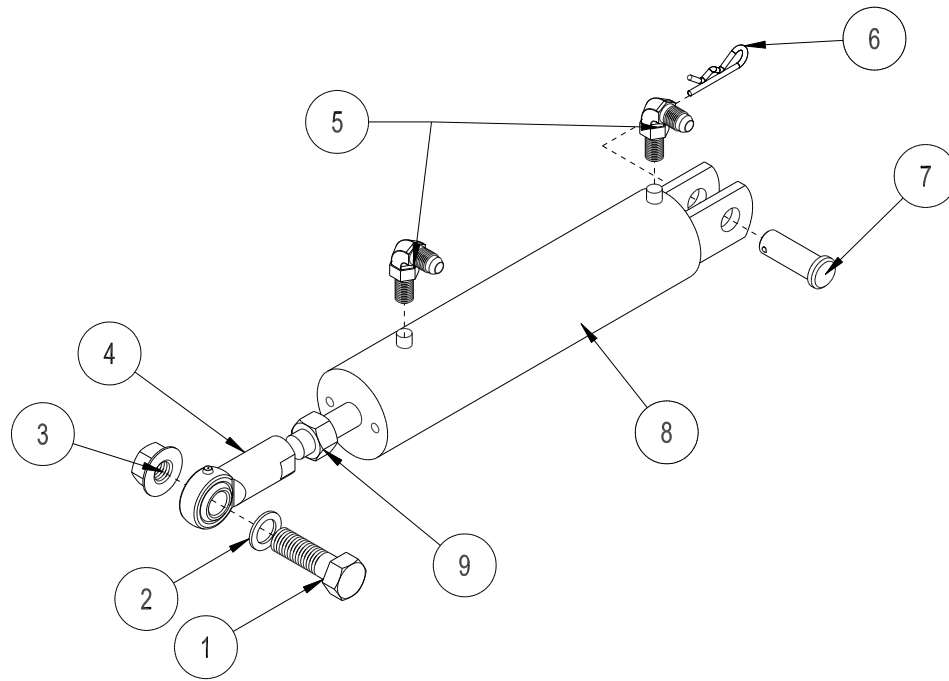

REF#	PART#	DESCRIPTION	QUANTITY
1	HB-58-11-250	Hex Bolt, $\frac{5}{8}$ - 11 x 2 $\frac{1}{2}$	1
2	HMB-58-14	Machine Bushing, $\frac{5}{8}$ - 14GA	2
3	HNTL-58-11	Nylon Lock Nut, $\frac{5}{8}$ - 11GA	1
4	18-154	Rod End	1
	HG-14-28-180	Grease Fitting, $\frac{1}{4}$ - 28 x 180°	1
5	18-168	Elbow	2
6	HHP-18	Bridge Pin, $\frac{1}{8}$	1
7	HCP-58-175	Clevis Pin, $\frac{5}{8}$ x 1 $\frac{3}{4}$	1
8	15-839	Hydraulic Cylinder	1
	15-839-01	Seal Kit	1
9	HNJ-58-18	Jam Nut, $\frac{5}{8}$ - 18	1

FRONT AXLE DRAWING

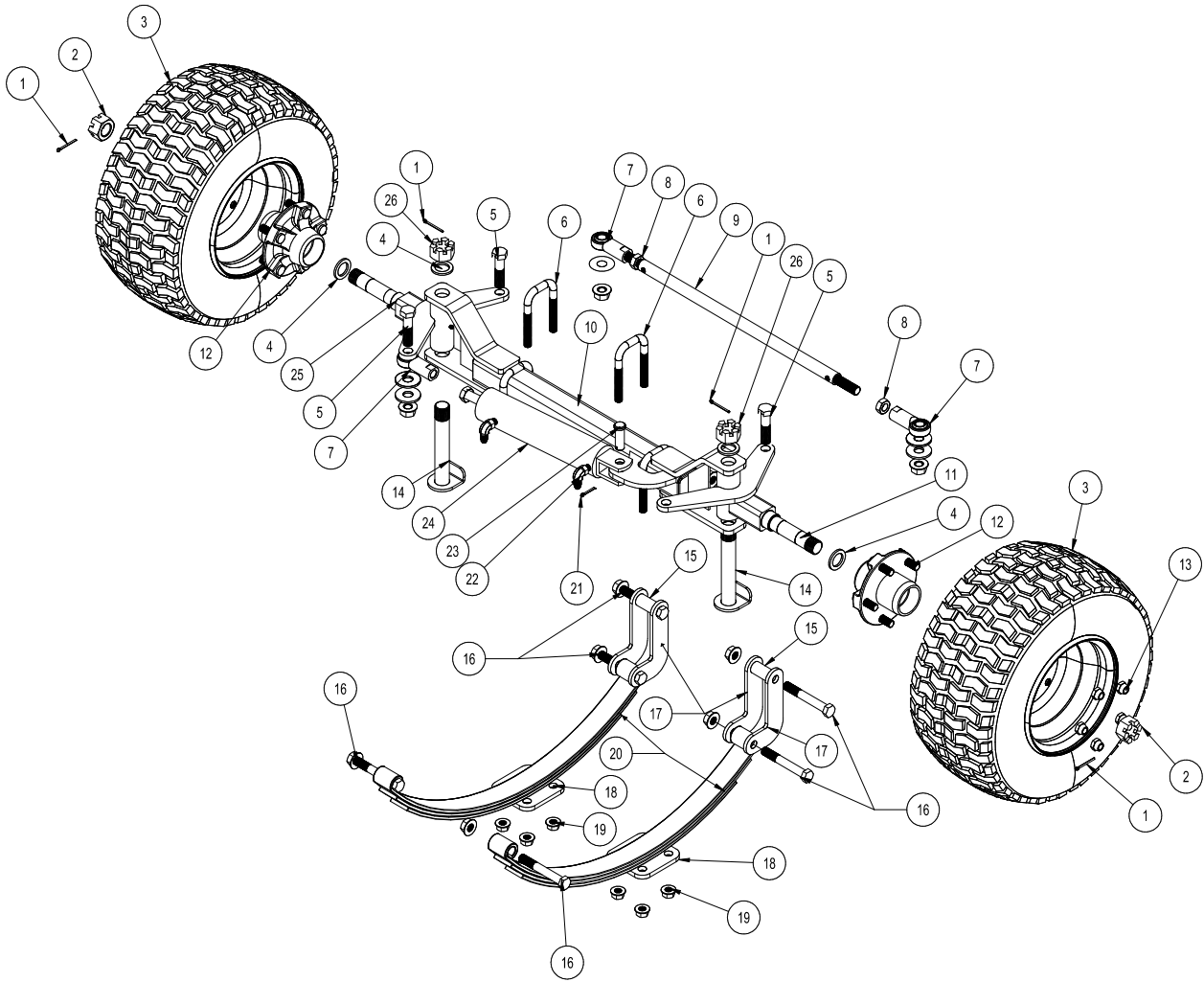

PARTS

FRONT AXLE PARTS LIST

REF#	PART#	DESCRIPTION	QUANTITY
1	HP-18-150	Cotter Pin, 1/8 - 1 1/2	4
2*	HNAR-100-14	Slotted Jam Nut, 1 -14	2
3	52-120	Front Tire and Rim	2
	52-120-01	Tire, 20 x 10.00 x 10 4-ply	2
	16-857-02	Rim	2
4	HMB-100-10	Machine Bushing, 1 x 10GA	4
5	HB-58-11-250	Hex Bolt, 5/8 -11 x 2 1/2	3
	HMB-58-14	Machine Bushing, 5/8 x 14GA	6
	HNTL-58-11	Nylon Lock Nut, 5/8 - 11	3
6	20-555	U-Hex Bolt	4
7	18-154	Rod End	3
	HG-14-28-180	Grease Fitting, 1/4 - 28 x 180°	3
8	HNJ-58-18	Jam Nut, 5/8 - 18	3
9	76-612	Steering Linkage	1
10	76-611	Front Axle	1
11	76-610	LH Spindle	1
12*	30-071	Hub Assembly (includes * items)	2
*	11-041	Seal	2
*	11-043	Bearing	2
13*	HNL-12-20	Lug Nut, 1/2 - 20	10
14	16-076	King Pin	2
15	30-251	Bushing	2
16	HB-916-18-325	Hex Bolt, 9/16 - 18 x 3 1/4	6
	HNTL-916-18	Nylon Lock Nut, 9/16 - 18	6
17	76-571	Shackle	4
18	20-538	Spring Mount	2
19	HNFL-12-13	Flange Whiz-loc Nut, 1/2 - 13	8
20	20-740	Leaf Spring	2
21	HP-18-100	Cotter Pin, 1/8 x 1	1
22	18-168	3/8 Straight Elbow	2
23	HCP-58-175	Clevis Pin, 5/8 x 1 3/4	1
24	15-839	Hydraulic Cylinder	1
25	76-609	RH Spindle	1
26	HNAR-100-14	Slotted Jam Nut, 1 -14	2

SEAT DRAWING

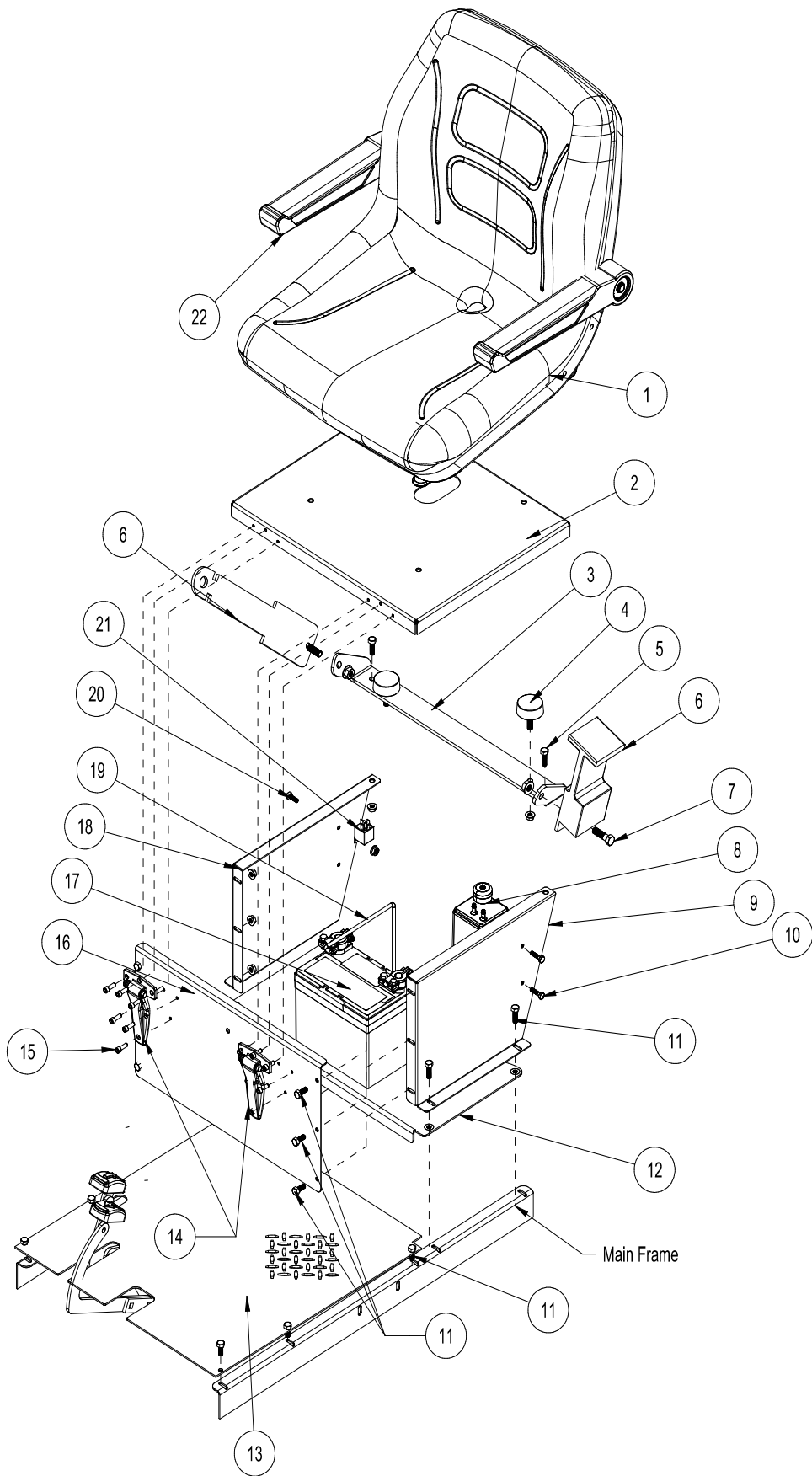

Parts

SEAT PARTS LIST

REF#	PART#	DESCRIPTION	QUANTITY
1	45-529	Seat with Suspension	1
	45-529-01	Seat Switch	1
2	76-576	Seat Panel	1
3	76-572	Bumper Support	1
4	50-081	Rubber Insulator	2
	HNFL-38-16	Flange Whiz-loc Nut, $\frac{3}{8}$ - 16	2
5	HB-516-18-100	Hex Bolt, $\frac{5}{16}$ - 18 x 1	2
	HNTL-516-18	Nylon Nylon Lock Nut, $\frac{5}{16}$ -18	2
6	76-198-03	Seat Belt	1
7	HB-716-14-100	Hex Bolt, $\frac{7}{16}$ - 14 x 1	2
	HW-38	Flat Washer, $\frac{3}{8}$	2
	HNTL-716-14	Nylon Lock Nut, $\frac{7}{16}$ - 14	2
8	8-738	Carbon Canister Assembly	1
	8-688	Carbon Canister Mount	1
9	76-587	LH Side Panel	1
10	HB-516-18-075	Hex Bolt, $\frac{5}{16}$ -18 x $\frac{3}{4}$	2
	HNFL-516-18	Nylon Lock Nut, $\frac{5}{16}$ - 18	2
11	HB-14-20-075	Hex Bolt, $\frac{1}{4}$ - 20 x $\frac{3}{4}$	16
	HW-14	Flat Washer, $\frac{1}{4}$	16
	HNFL-14-20	Flange Whiz-loc Nut, $\frac{1}{4}$ - 20	16
12	76-588	Battery Tray	1
	8803-8	Black Trim	2
13	76-600	Floorboard	1
14	27-055	Black Flush Hinge	2
15	HSMFCS-10-32-050	Flat Head Machine Screw, #10 - 32 x $\frac{1}{2}$	12
	HNFL-10-32	Flange Whiz-loc Nut, #10 - 32	12
16	76-593	Front Seat Panel	1
17	33-216	Battery	1
18	76-586	RH Side Panel	1
19	76-618	Battery Hold-down	1
	HNFL-14-20	Flange Whiz-loc Nut, $\frac{1}{4}$ -20	2
20	HSM-10-32-063	Machine Screw, #10 - 32 x $\frac{5}{8}$	1
	HNFL-10-32	Flange Whiz-loc Nut, #10 - 32	1
21	30-042-06	Relay	1
22	45-529-02	Arm Rests	1

FOOT PEDAL LINKAGE DRAWING

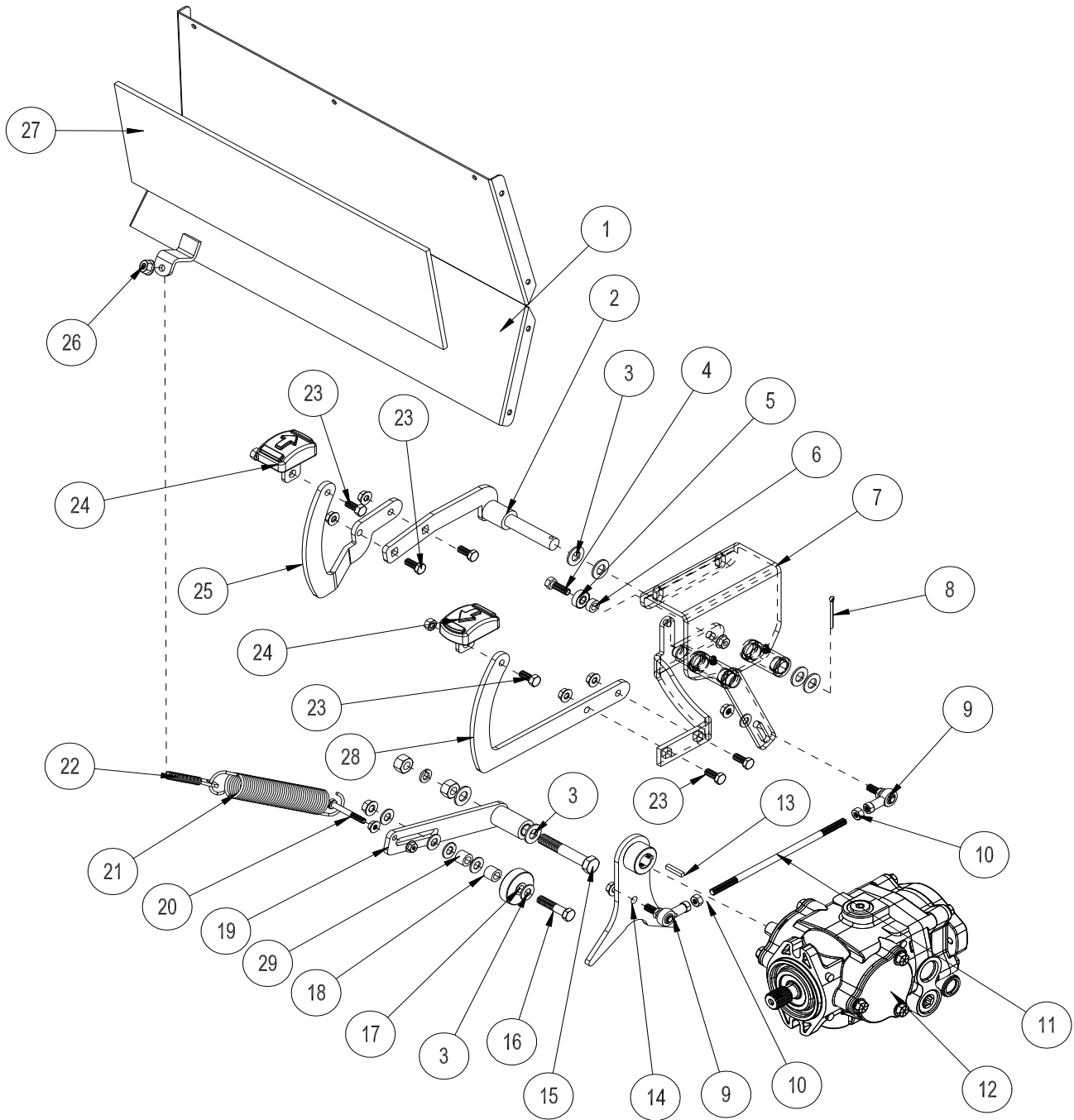

PARTS

FOOT PEDAL LINKAGE PARTS LIST

REF#	PART#	DESCRIPTION	QUANTITY
1	76-590	Firewall	1
2	76-614	Reverse Pedal Relay	1
3	HMB-12-14	Machine Bushing, 1/2 x 14GA	6
4	HB-516-18-125	Hex Bolt, 5/16 - 18 x 1 1/4	1
	HNFL-516-18	Flange Whiz-loc Nut, 5/16 - 18	1
5	8-601	Micro Ball Bearing	1
6	8-622	Spacer	1
7	76-613	Pedal Relay	1
	HG-14-28-180	Grease Fitting, 1/4 - 28 x 180°	2
8	HP-18-100	Cotter Pin, 1/8 x 1	1
9	18-441	Ball Joint, 5/16 - 24	2
10	HN-516-24	Hex Nut, 5/16 - 24	4
11	43-220	Speed Boss Link	1
12	76-638	Hydrostatic Pump	1
13	HKSQ-14-150	Square Key, 1/4 x 1 1/2	1
14	76-607	Swash Arm	1
15	HB-12-13-300	Hex Bolt, 1/2 - 13 x 3	1
	HWL-12	Lock Washer, 1/2	1
	HNTL-12-13	Nylon Lock Nut, 1/2 - 13	1
16	HB-38-16-175	Hex Bolt, 3/8 - 16 x 1 3/4	1
	HW-38	Flat Washer, 3/8	5
	HNTL-38-16	Nylon Lock Nut, 3/8 - 16	1
17	14-266	Ball Bearing	1
18	18-270	Oilite Bushing	1
19	76-606	Idler Arm	1
	HG-14-28-180	Grease Fitting, 1/4 - 28 x 180°	1
20	HB-14-20-200	Hex Bolt, 1/4 - 20 x 2	1
	HNFL-14-20	Flange Whiz-loc Nut, 1/4 -20	2
21	21-445	Spring	1
22	42-537	Spade Hex Bolt, 3/8	1
23	HBCL-516-18-075	Low Shoulder Carriage Hex Bolt, 5/16 - 18 x 3/4	6
	HNFL-516-18	Flange Whiz-loc Nut, 5/16 - 18	6
24	45-022	Molded Foot Pedal	2
25	76-566	Reverse Pedal Arm	1
26	HNTL-38-16	Nylon Lock Nut, 3/8 - 16	1
27	9023	Ceramic Mat, 7" x 20"	1 Sheet
28	76-565	Forward Pedal Arm	1
29	10-134	Spacer	1

DASH PANEL DRAWING

Parts

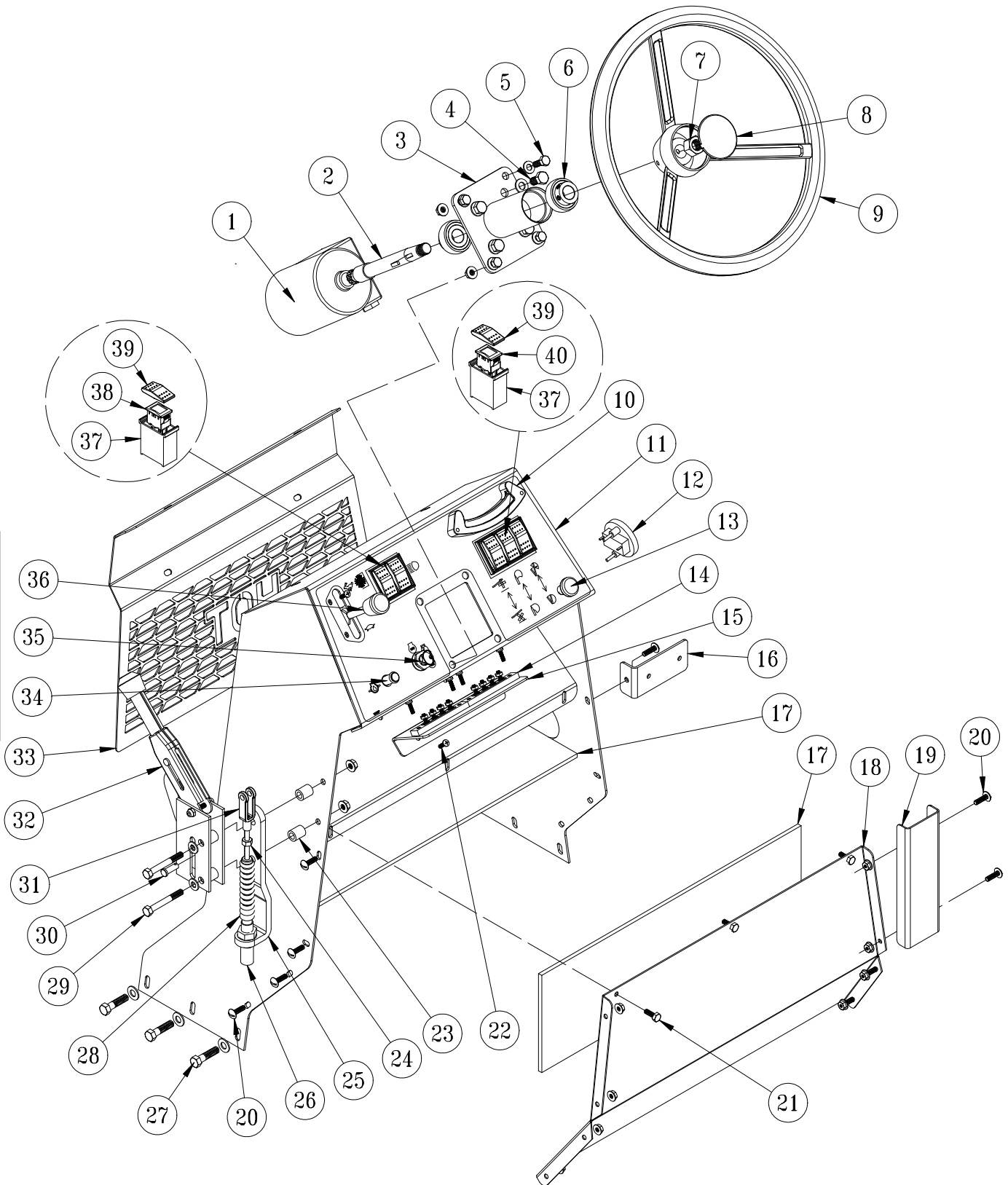

DASH PANEL PARTS LIST

REF#	PART#	DESCRIPTION	QUANTITY
1	76-559	Orbitrol	1
2	45-440	Splined Shaft	1
	HWK-316-063	Woodruff Key, $\frac{3}{16} \times \frac{5}{8}$	1
3	76-530	Steering Column	1
4	HBM-10-1.5-20	Metric Hex Bolt, #10 - 1.5 x 20	4
	HWLM-10	Metric Lock Washer, #10	4
5	HB-516-18-100	Hex Bolt, $\frac{5}{16}$ - 18 x 1	4
	HNFL-516-18	Flange Whiz-loc Nut, $\frac{5}{16}$ - 18	4
6	45-155	Flange Bearing	2
7	HNJ-58-18	Jam Nut, $\frac{5}{8}$ - 18	1
8	21-499	Center Cap	1
9	21-498	15" Steering Wheel	1
10	76-372	Inclinometer	1
11	76-660	Dash Console	1
	76-536	Decal, Dash Panel	1
12	12-804	Hour Meter	1
13	11-086	Choke Cable	1
14	8935	Buss Bar	2
15	76-657	Buss Bar Mount	1
16	76-658	Hose Bracket	1
17	9023	Ceramic Foil (7" x 20")	1 Sheet
18	76-590	Firewall	1
19	76-568	Wire Channel	1
20	HSTP-14-20-075	Truss Head Hex Bolt, $\frac{1}{4}$ - 20 x $\frac{3}{4}$	8
	HNFL-14-20	Nylon Lock Nut, $\frac{1}{4}$ - 20	8
21	HB-14-20-075	Hex Bolt, $\frac{1}{4}$ - 20 x $\frac{3}{4}$	3
	HNFL-14-20	Flange Whiz-loc Nut, $\frac{1}{4}$ - 20	3
22	HSM-10-32-063	Machine Screw, #10 - 32 x $\frac{5}{8}$	6
	HNFL-10-32	Flange Whiz-loc Nut, #10 - 32	6
23	10-134	Spacer	2
24	HN-516-24	Nut, $\frac{5}{16}$ - 24	1
25	45-605	Park Brake Bracket	1
26	76-225	Brake Cable	1
27	HB-516-18-125	Hex Bolt, $\frac{5}{16}$ - 18 x $1\frac{1}{4}$	6
	HW-516	FLat Washer, $\frac{5}{16}$	6
	HNTL-516-18	Nylon Lock Nut, $\frac{5}{16}$ - 18	6
28	60-536	Bellow	1
29	HB-516-18-250	Hex Bolt, $\frac{5}{16}$ - 18 x $2\frac{1}{2}$	2
	HNTL-516-18	Nylon Lock Nut, $\frac{5}{16}$ - 18	2
30	HCP-516-100	Clevis Pin, $\frac{5}{16} \times 1$	1
	HP-18-100	Cotter Pin, $\frac{1}{8} \times 1$	1
31	11-100	Yoke	1
32	60-106	Brake Lever w/ Kit	1
33	76-659	Muffler Guard	1
34	50-539	Warning Indicator Light	1
35	13-488	Ignition Switch	1
36	45-118	Throttle Cable	1
	HSM-10-32-063	Machine Screw, #10 - 32 x $\frac{5}{8}$	2
	HNFL-10-32	Flange Whiz-loc Nut, #10 - 32	2
37	15-725	Mount Panel, End	4
	15-729	Mount Panel, Middle	1
38	15-782	Unlit Switch, On-none-On	2
39	15-727	Rocker, Unlit	5
40	15-728	Centering Switch, On-Off-On	3

OIL COOLER AND ROPS DRAWING

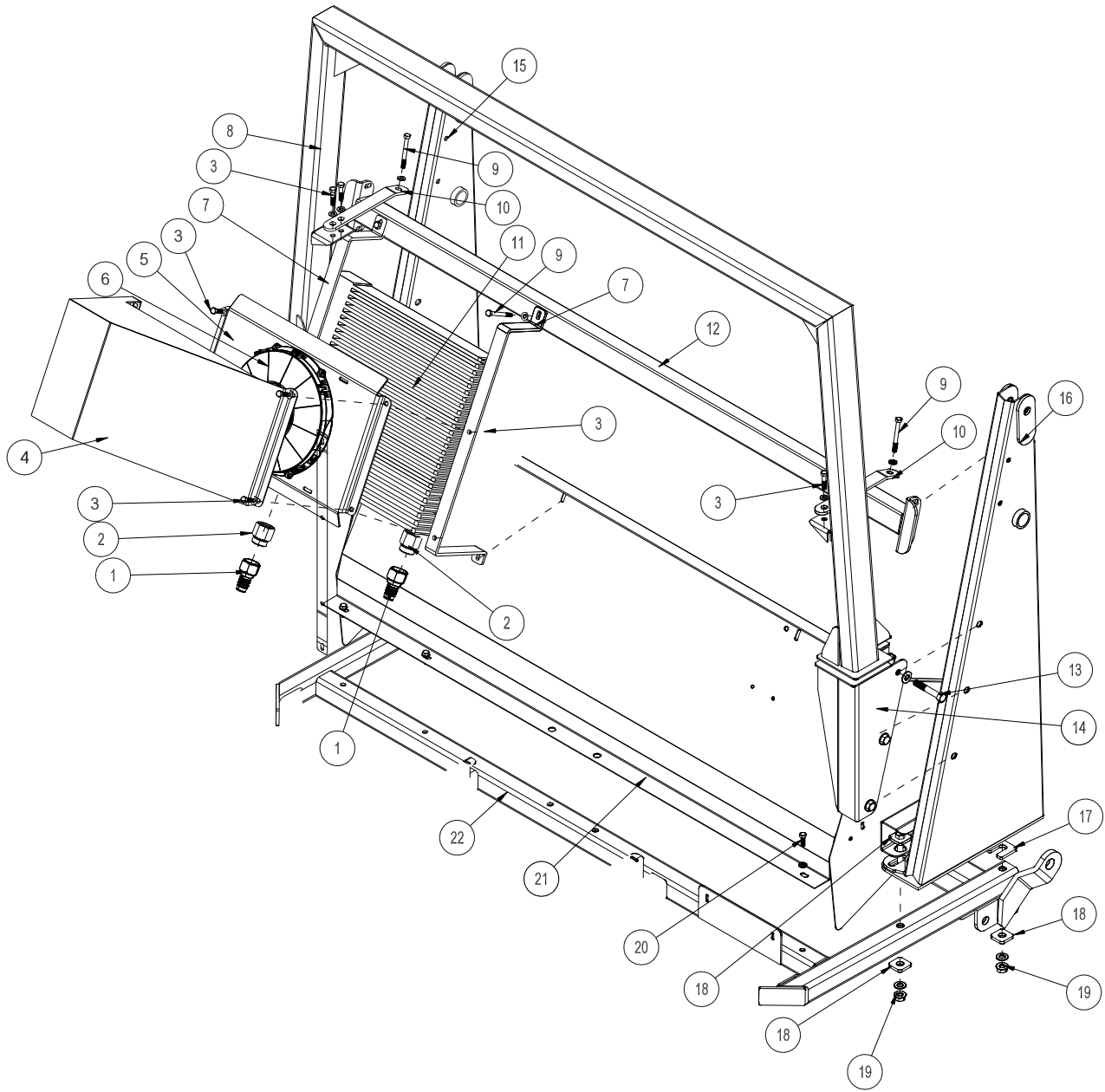

Parts

OIL COOLER AND ROPS PARTS LIST

REF#	PART#	DESCRIPTION	QUANTITY
1	18-469	Swivel Hose Barb	2
2	18-468	Straight Thread Connector	2
3	HB-516-18-150	Hex Bolt, $\frac{5}{16}$ - 18 x $1\frac{1}{2}$	8
	HW-516	Flat Washer, $\frac{5}{16}$	8
	HNTL-516	Nylon Lock Nut, $\frac{5}{16}$ - 18	8
4	76-631	Deflector	1
5	76-575	Cooler Fan Mount	1
	8803-17	Black Trim, 17"	2
6	76-544	Fan	1
7	76-573	Cooler Strap	2
8	76-381	ROP Bar	1
9	HB-516-18-300	Hex Bolt, $\frac{5}{16}$ - 18 x 3	6
	HW-516	Flat Washer, $\frac{5}{16}$	6
	HNTL-516-18	Nylon Lock Nut, $\frac{5}{16}$ - 18	6
10	76-376	Strap	2
11	76-561	Oil Cooler	1
12	75-570	Cross Bar	1
13	HB-12-13-300	Hex Bolt, $\frac{1}{2}$ - 13 x 3	6
	HW-12	Washer, $\frac{1}{2}$	6
	HNTL-12-13	Nylon Lock Nut, $\frac{1}{2}$ -13	6
14	76-380	LH ROP Support - Shown	1
	76-379	RH ROP Support	1
15	75-629	LH Tower	1
16	75-561	RH Tower	1
17	75-703	Tower Spacer	2
18	76-151	Tower Washer	8
19	HB-12-13-400	Hex Bolt, $\frac{1}{2}$ - 13 x 4	4
	HMB-12-14	Machine Bushing, $\frac{1}{2}$ x 14GA	4
	HNTL-12-13	Nylon Lock Nut, $\frac{1}{2}$ -13	4
20	HB-516-18-100	Hex Bolt, $\frac{5}{16}$ - 18 x 1	3
	HW-516	Flat Washer, $\frac{5}{16}$	3
21	76-235	Grass Chute Frame	1
	8803-60	Black Trim, 60"	1
22	76-617	Main Frame	1

GAS TANK AND MANIFOLD DRAWING

Parts

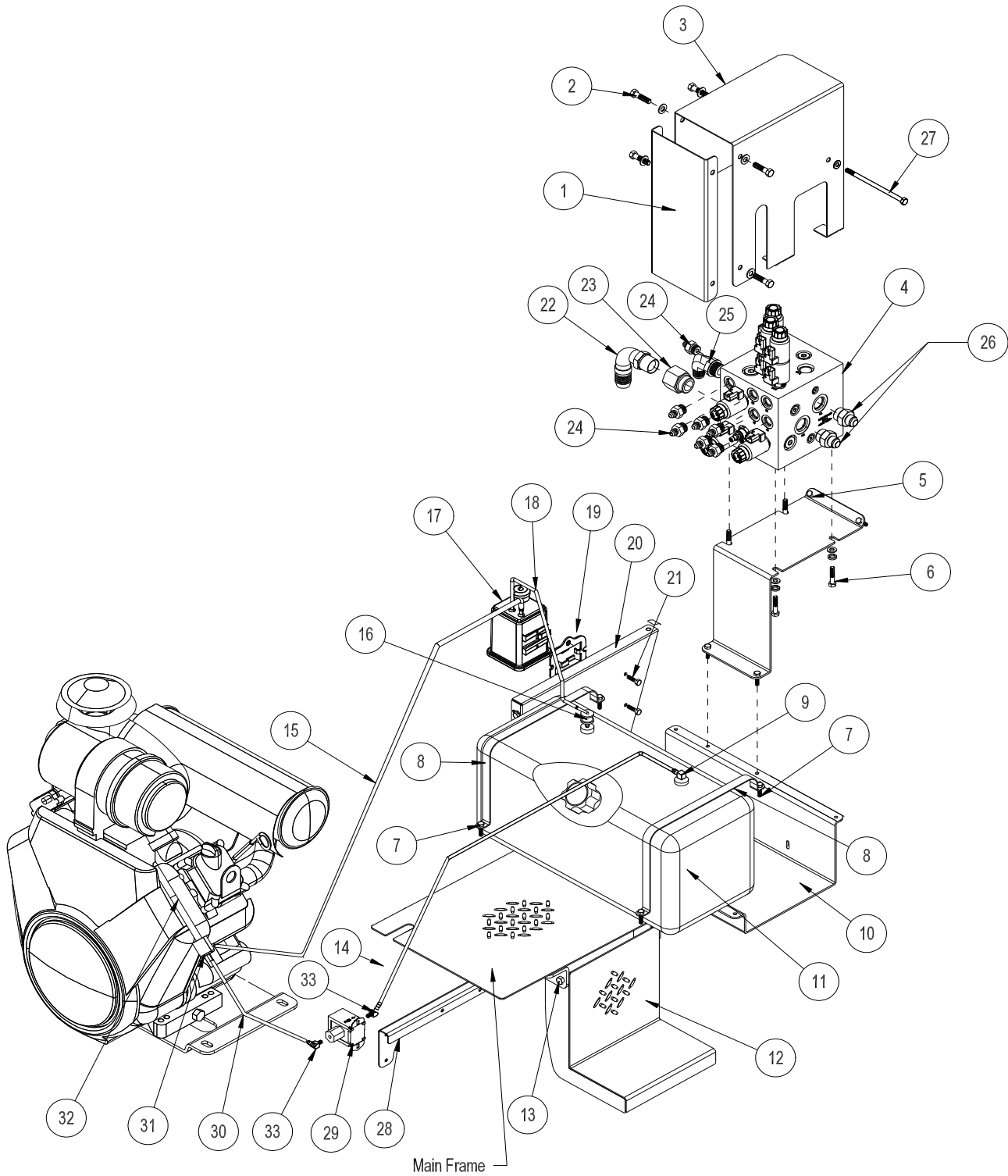

GAS TANK AND MANIFOLD PARTS LIST

REF#	PART#	DESCRIPTION	QUANTITY
1	76-601	Cover Panel	1
2	HB-516-18-100	Hex Bolt, $\frac{5}{16}$ - 18 x 1	4
	HW-516	Flat Washer, $\frac{5}{16}$	4
	HNTL-516-18	Nylon Lock Nut, $\frac{5}{16}$ - 18	4
3	76-603	Manifold Cover	1
4	76-560	Hydraulic Manifold	1
5	76-599	Valve Mount	1
	HB-14-20-124	Hex Bolt, $\frac{1}{4}$ - 20 x $1\frac{1}{4}$	4
	HNFL-14-20	Flange Whiz-loc Nut, $\frac{1}{4}$ - 20	4
6	HB-38-16-150	Hex Bolt, $\frac{3}{8}$ - 16 x $1\frac{1}{2}$	4
	HWL-38	Lock Washer, $\frac{3}{8}$	4
	HMB-12-14	Machine Bushing, $\frac{1}{2}$ x 14GA	4
7	HB-14-20-250	Hex Bolt, $\frac{1}{4}$ - 20 x $2\frac{1}{2}$	2
	HW-14	Flat Washer, $\frac{1}{4}$	2
	HNFL-14-20	Flange Whiz-loc Nut, $\frac{1}{4}$ - 20	2
8	76-585	Gas Tank Strap	2
9		Top Draw	1
10	76-591	Gas Tank Bracket	1
11	76-546	CARB Gas Tank - 8 Gallon	1
12	76-605	Step	1
13	HB-38-16-100	Hex Bolt, $\frac{3}{8}$ - 16 x 1	2
	HNTL-38-16	Nylon Lock Nut $\frac{3}{8}$ - 16	2
14	8800-44	$\frac{1}{4}$ " Fuel Line x 44"	1
	18-186	Hose Clamp	2
15	9025-60	$\frac{3}{16}$ " Fuel Line x 60"	1
	18-186	Hose Clamp	2
16		Roll-over Valve	1
17	8-738	Carbon Canister Assembly	1
18	8800-19	$\frac{1}{4}$ " Fuel Line x 19"	1
	18-186	Hose Clamp	2
19	8-688	Carbon Canister Mount	1
20	76-587	LH Side Panel	1
21	HB-14-20-075	Hex Bolt, $\frac{1}{4}$ - 20 x $\frac{3}{4}$	2
	HNFL-14-20	Flange Whiz-loc Nut, $\frac{1}{4}$ - 20	2
22	18-397	90° Hose Barb	1
23	18-471	Straight Thread Reducer	1
24	18-241	Straight Thread Connector	7
25	18-204	Elbow	1
26	15-702	Adapter	2
27	HB-516-18-700	Hex Bolt, $\frac{5}{16}$ - 18 x 7	1
	HW-516	Flat Washer, $\frac{5}{16}$	2
	HNTL-516-18	Nylon Lock Nut, $\frac{5}{16}$ - 18	1
28	76-632	Fuel Pump Mount	1
29	76-757	Electric Fuel Pump	1
30	8800-18	$\frac{1}{4}$ " Fuel Line x 18"	1
	18-186	Hose Clamp	2
31	50-403	Inline Fuel Filter	1
32	8800-14	$\frac{1}{4}$ " Fuel Line x 14"	1
	18-186	Hose Clamp	2
33	18-420	45° Barb	2

OIL TANK DRAWING

PARTS

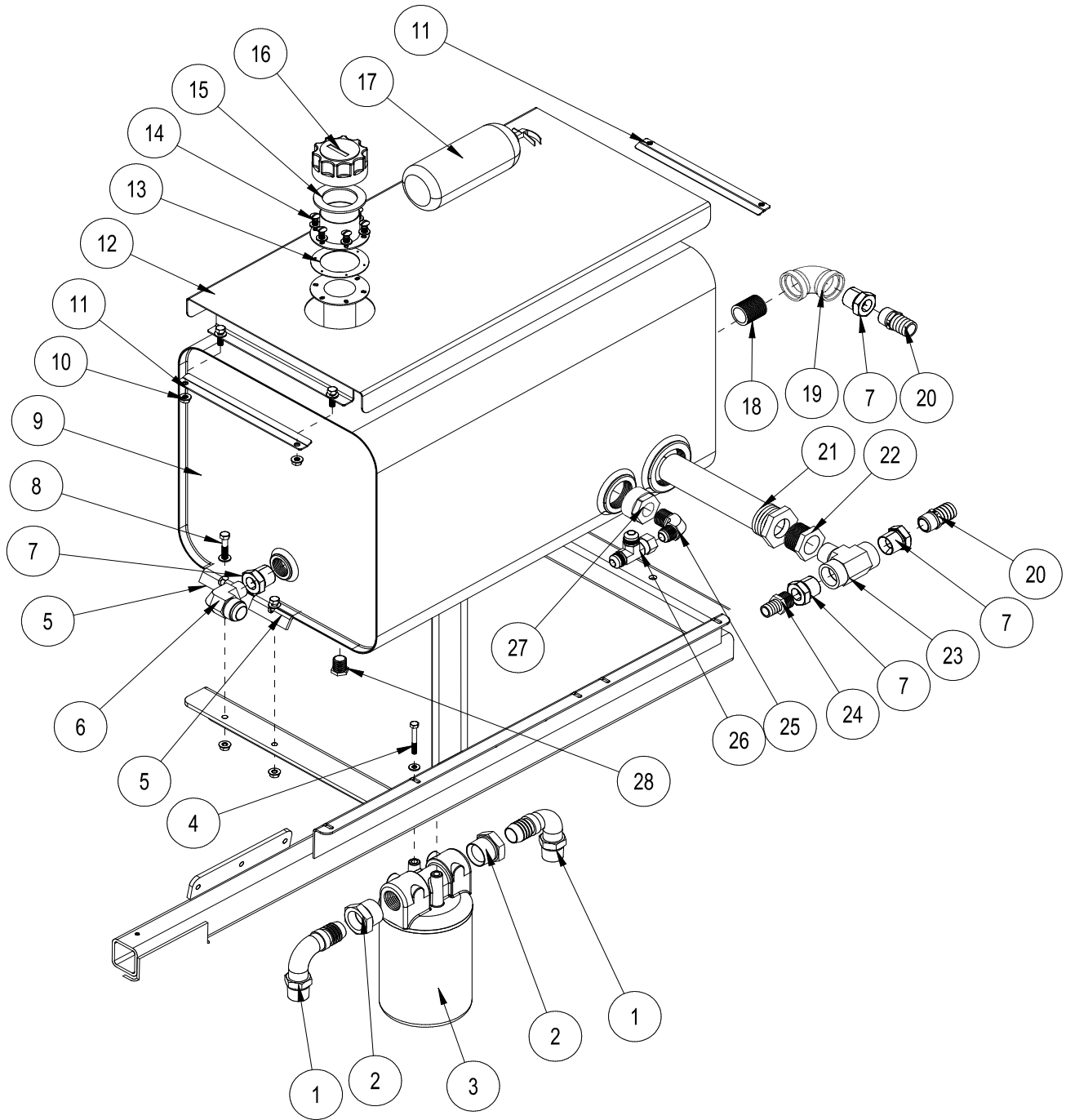

OIL TANK PARTS LIST

REF#	PART#	DESCRIPTION	QUANTITY
1	18-397	90° Hose Barb	2
2	18-396	Reducer	2
3	72-146	Oil Filter Assembly	1
	60-334	Filter Element	1
4	HB-14-20-200	Hex Bolt, 1/4 - 20 x 2	2
	HW-14	Washer, 1/4	2
5	75-792	Tank Hold-down	4
6	18-472	Elbow	1
7	18-107	Pipe Thread Reducer	4
8	HB-516-18-150	Hex Bolt, 5/16 - 18 x 1 1/2	3
	HW-516	Washer, 5/16	3
	HNTL-516	Nylon Lock Nut, 5/16 - 18	3
9	76-545	Oil Tank	1
10	HNFL-14-20	Flange Whiz-loc Nut, 1/4 - 20	4
	HW-14	Washer, 1/4	4
	HB-14-20-075	Hex Bolt, 1/4 - 20 x 3/4	4
11	76-592	Cover Strap	2
12	76-602	Tank Cover	1
13	13-586-02	Bottom Gasket	1
14	13-586-03	Filler Neck	1
	HSM-10-32-063	Machine Screw, #10-32 x 5/8	6
	HWL-10	Lock Washer, #10	6
15	13-586-01	Cap Gasket	1
16	13-747	Filler Breather	1
17	76-354	Fire Extinguisher	1
18	18-120	1" Black Nipple	1
19	18-050	1" Black Elbow	1
20	18-250	Barb Fitting	2
21	76-564	Tank Strainer	1
22	16-824	Pipe Reducer Bushing	1
23	18-473	Branch Tee	1
24	18-249	Barb Fitting	1
25	23-071	Male Connector	1
26	34-058	Swivel Tee	1
27	18-280	Reducer Bushing	1
28	18-069	Pipe Plug, 1/2"	1

ENGINE AND EXHAUST DRAWING

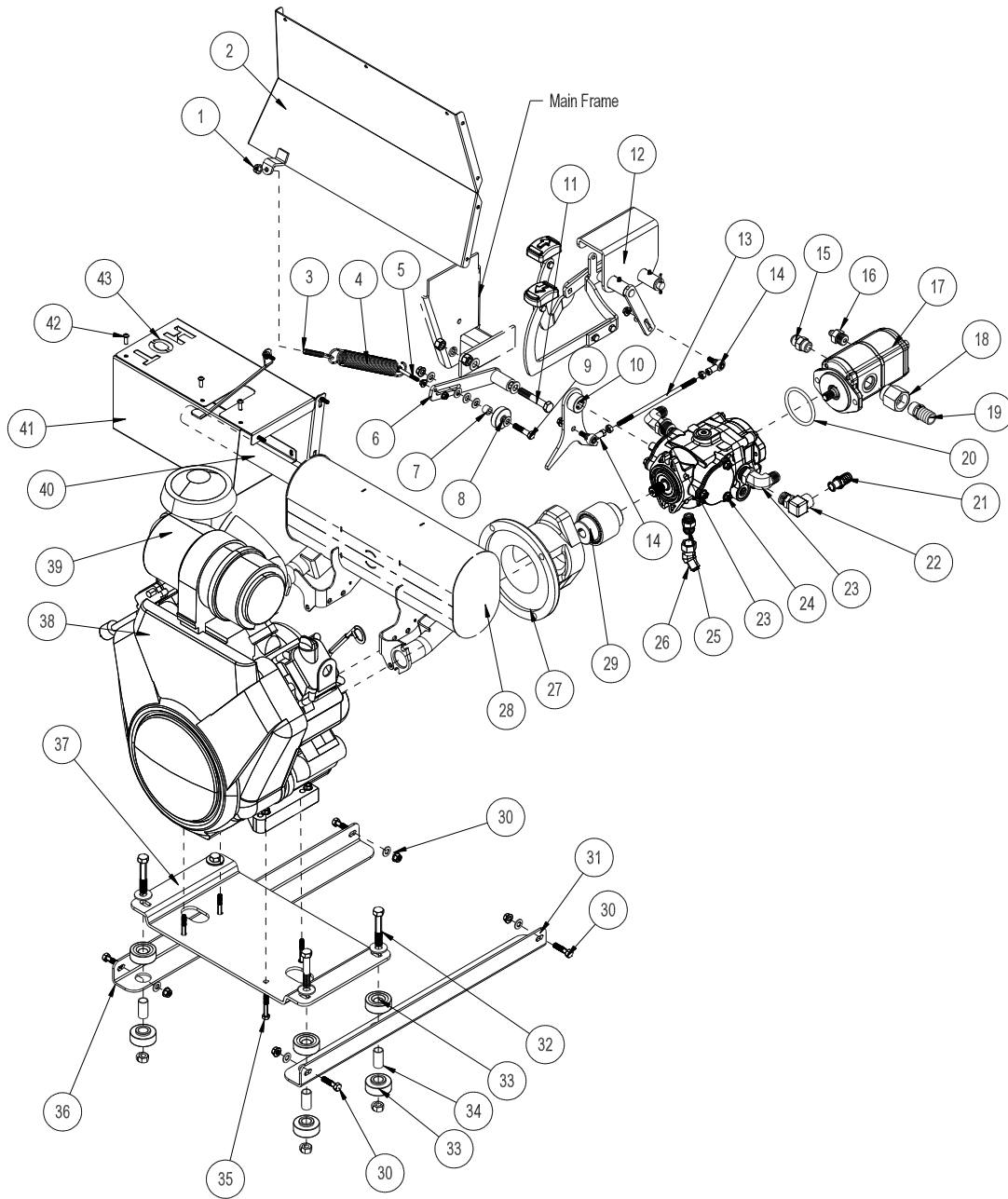

PARTS

Cyclonic air cleaner
76-395-04

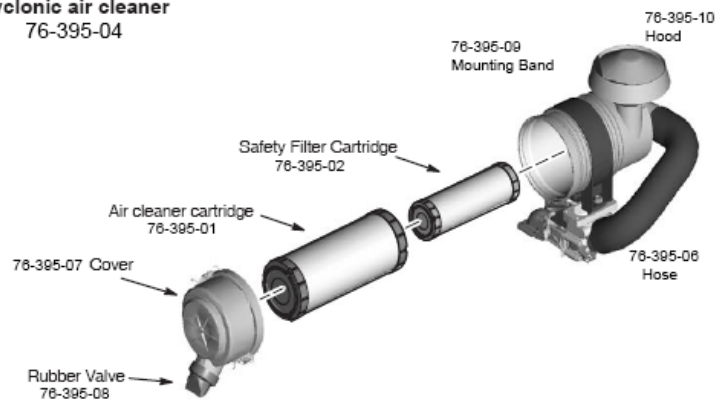

ENGINE AND EXHAUST PARTS LIST

REF#	PART#	DESCRIPTION	QUANTITY
1	HNTL-38-16	Nylon Lock Nut, $\frac{3}{8}$ - 16	1
2	76-590	Firewall	1
	9023	Ceramic Foil (7" x 20")	1 Sheet
3	42-537	Spade Hex Bolt, $\frac{3}{8}$	1
4	21-445	Spring	1
5	HB-14-20-200	Hex Bolt, $\frac{1}{4}$ - 20 x 2	1
	HNFL-14-20	Flange Whiz-loc Nut, $\frac{1}{4}$ - 20	2
6	76-606	Idler Arm	1
	HG-14-28-180	Grease Fitting, $\frac{1}{4}$ - 28 x 180°	1
7	18-270	Oilite Bushing	1
8	14-266	Ball Bearing	1
9	HB-38-16-175	Hex Bolt, $\frac{3}{8}$ - 16 x $1\frac{3}{4}$	1
	HW-38	Flat Washer, $\frac{3}{8}$	5
	HNTL-38-16	Nylon Lock Nut, $\frac{3}{8}$ - 16	1
10	76-607	Swash Arm	1
11	HB12-13-300	Hex Bolt, $\frac{1}{2}$ - 13 x 3	1
	HWL-12	Lock Washer, $\frac{1}{2}$	1
	HNTL-12-13	Nylon Lock Nut, $\frac{1}{2}$ - 13	1
12	76-613	Pedal Relay	1
	HG-14-28-180	Grease Fitting, $\frac{1}{4}$ - 28 x 180°	2
13	43-220	Speed Boss Link	1
14	18-441	Ball Joint, $\frac{5}{16}$ - 24	2
	HN-516-24	Hex Nut, $\frac{5}{16}$ - 24	4
15	18-505	Straight Thread Connector	1
16	18-331	Adapter	1
17	76-540	Gear Pump	1
18	23-136	Straight Thread Reducer	1
19	18-250	Barb Fitting	1
20	23-145	O-ring	1
21	18-133	Barb Fitting	1
22	23-130	Elbow	1
23	18-204	Elbow	2
24	76-638	Hydrostatic Pump	1
25	18-267	Straight Thread Connector	1
26	18-273	Fitting	1
27	76-537	Pump Adapter	1
28	76-625	Muffler	1
	76-749-01	Exhaust Gasket	2
29	76-465	Coupling Complete	1
	76-466	$\frac{7}{8}$ " Coupler Half	
	76-467	$1\frac{1}{8}$ " Coupler Half	
	76-468	Coupler Sleeve	
30	HB-38-16-150	Hex Bolt, $\frac{3}{8}$ - 16 x $1\frac{1}{2}$	4
	HW-38	Flat Washer, $\frac{3}{8}$	4
	HNTL-38-16	Nylon Lock Nut, $\frac{3}{8}$ - 16	4
31	76-579	LH Motor Mount	1
32	HB-38-16-225	Hex Bolt, $\frac{3}{8}$ - 16 x $2\frac{1}{4}$	4
	HW-38	Flat Washer, $\frac{3}{8}$	4
	HNTL-38-16	Nylon Lock Nut, $\frac{3}{8}$ - 16	4
33	60-107	Rubber Bushing	8
34	60-168	Spacer	4
35	HB-716-14-150	Hex Bolt, $\frac{7}{16}$ - 14 x $1\frac{1}{2}$	4
	HWL-716	Lock Washer, $\frac{7}{16}$	4
36	76-578	RH Motor Mount	1
37	76-582	Engine Plate	1
38	76-749	Briggs 35HP Engine	1
39	76-395-04	Cyclonic Air Cleaner (comes with engine)	1
40	76-626	Tailpipe	1
	50-111	Muffler Clamp	1
41	76-630	Bottom Heat Shield	1
	9023	Ceramic Mat (13 x 13.5)	1
42	HSTP-14-20-075	Machine Screw, $\frac{1}{4}$ - 20 x $\frac{3}{4}$	6
	HNFL-14-20	Flange Whiz-loc Nut, $\frac{1}{4}$ - 20	6
43	76-629	Top Heat Shield	1
	9023	Ceramic Mat (14 x 15)	1

REEL BELT DRIVE DRAWING

PARTS

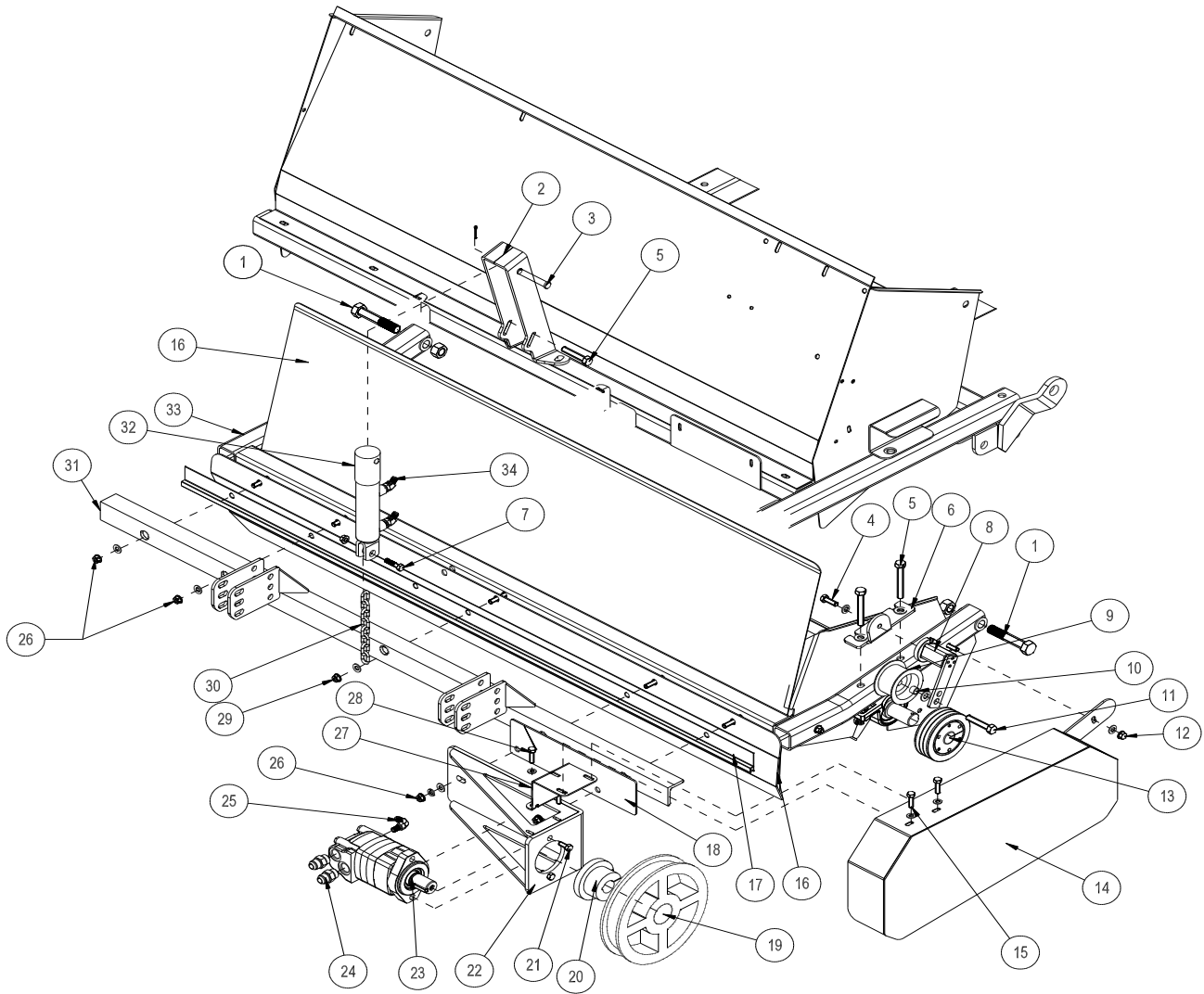

REEL BELT DRIVE PARTS LIST

REF#	PART#	DESCRIPTION	QUANTITY
1	HB-34-10-400	Hex Bolt, $\frac{3}{4}$ -10 x 4	2
	HNTL-34-10	Nylon Lock Nut, $\frac{3}{4}$ -10	2
2	75-827	Cylinder Bracket	1
3	HCP-12-350	Clevis Pin, $\frac{1}{2}$ x 3 $\frac{1}{2}$	1
	HP-18-100	Cotter Pin, $\frac{1}{8}$ x 1	1
4	HBM-10-1.5-30	Metric Hex Bolt, 10-1.5 x 30 (part of 78-224)	1
	HWLM-10	Metric Lock Washer, 10 (part of 78-224)	1
5	HB-12-13-400	Hex Bolt, $\frac{1}{2}$ -13 x 4	5
	HMB-12-14	Machine Bushing, $\frac{1}{2}$ x 14GA	4
	HNTL-12-13	Nylon Lock Nut, $\frac{1}{2}$ - 13	5
6	76-569	Idler Mount	1
7	HB-38-16-150	Hex Bolt, $\frac{3}{8}$ - 16 x 1 $\frac{1}{2}$	1
	HNTL-38-16	Nylon Lock Nut, $\frac{3}{8}$ - 16	1
8	78-224	Belt Tensioner	1
9	16-013	Idler Pulley	1
10	34-215	Spacer	1
11	HB-12-13-250	Hex Bolt, $\frac{1}{2}$ - 13 x 2 $\frac{1}{2}$ (part of 78-224)	1
	HMB-12-14	Machine Bushing, $\frac{1}{2}$ x 14GA	5
	HNCL-12-13	Center Nylon Lock Nut, $\frac{1}{2}$ - 13 (part of 78-224)	1
12	HB-38-16-300	Hex Bolt, $\frac{3}{8}$ - 16 x 3	1
	HW-38	Flat Washer, $\frac{3}{8}$	2
	HNTL-38-16	Nylon Lock Nut, $\frac{3}{8}$ -16	2
13	78-425	Pulley, 3-Groove	1
	78-431	Hub	1
14	76-604	Belt Guard	1
15	HBFL-516-18-075	Flange Hex Bolt, $\frac{5}{16}$ - 18 x $\frac{3}{4}$	2
	HNFL-516-18	Flange Whiz-loc Nut, $\frac{5}{16}$ -18	2
16	75-808	Front Baffle	1
17	76-438	Brush Channel	1
18	76-598	Shim	1
19	76-581	Pulley, 3-groove	1
20	76-580	Hub	1
	HWK-516-100	Woodruff Key, $\frac{5}{16}$ x 1	1
21	HB-12-13-200	Hex Bolt, $\frac{1}{2}$ - 13 x 2	2
	HWL-12	Lock Washer, $\frac{1}{2}$ - 13	2
22	76-608	Motor Mount	1
23	76-539	Reel Motor	1
24	18-505	Straight Thread Connector	2
25	18-478	Elbow	1
26	HB-38-16-350	Hex Bolt, $\frac{3}{8}$ - 16 x 3 $\frac{1}{2}$	4
	HW-38	Flat Washer, $\frac{3}{8}$	8
	HNTL-38-16	Nylon Lock Nut, $\frac{3}{8}$ - 16	4
27	76-567	Belt Guard Mount	1
28	HB-14-20-075	Hex Bolt, $\frac{1}{2}$ -20 x $\frac{3}{4}$	2
	HNFL-14-20	Flange Whiz-loc Nut, $\frac{1}{4}$ - 20	2
29	HB-38-16-400	Hex Bolt, $\frac{3}{8}$ - 16 x 4	1
	HW-38	Washer, $\frac{3}{8}$	2
	HNTL-38-16	Nylon Lock Nut, $\frac{3}{8}$ - 16	1
30	8820-8	Machine Chain, 8-links	1
31	76-356	Castor Mount Bracket	1
32	76-478	Hydraulic Cylinder	1
	14-531	Seal Kit	1
33	75-787	Reel Frame	1
34	18-188	45° Elbow	2
NS	76-621	Belt, 3V x 590	3

REAR AXLE DRAWING

PARTS

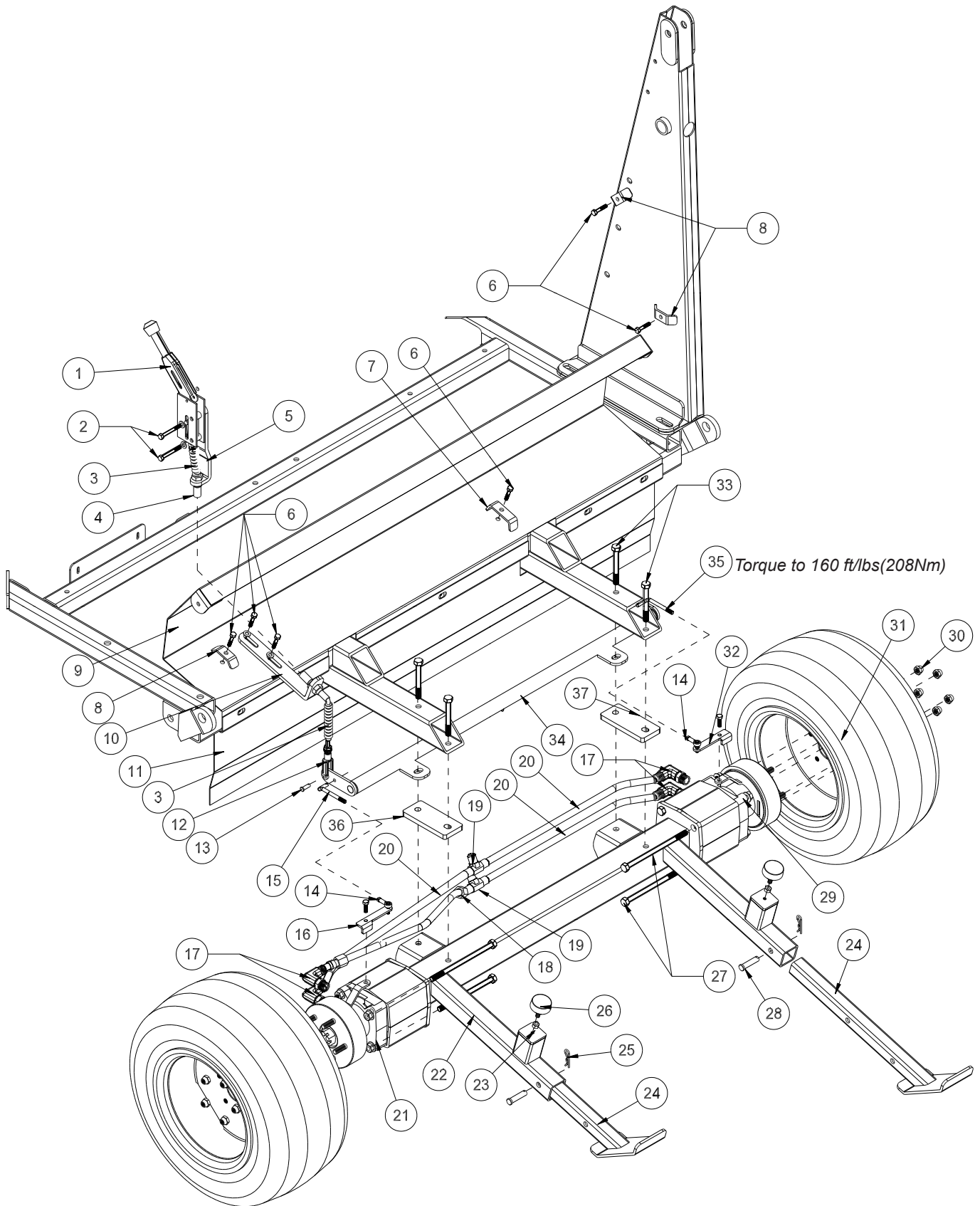

REAR AXLE PARTS LIST

REF#	PART#	DESCRIPTION	QUANTITY
1	60-106	Park Brake Lever Kit	1
2	HB-516-18-275	Hex Bolt, $\frac{5}{16}$ - 18 x $2\frac{3}{4}$	2
	HNTL-516-18	Nylon Lock Nut, $\frac{5}{16}$ - 18	2
3	60-536	Bellows	2
4	76-225	Brake Cable with Nuts	1
5	45-605	Park Brake Bracket	1
6	HB-38-16-150	Hex Bolt, $\frac{3}{8}$ - 16 x $1\frac{1}{2}$	6
	HW-38	Flat Washer, $\frac{3}{8}$	12
	HNTL-38-16	Nylon Lock Nut, $\frac{3}{8}$ - 16	6
7	75-614	Hose Clamp	1
8	13-099	Hose Clamp	3
9	76-234	Rear Chute Baffle	1
	8947-60	Trim Seal x 60"	1
10	76-218	Brake Cable Bracket	1
11	76-233	Rear Beater Panel	1
12	11-100	Linkage Yoke, $\frac{5}{16}$	1
13	HCP-516-100	Clevis Pin, $\frac{5}{16}$ x 1	1
	HP-18-075	Cotter Pin, $\frac{1}{8}$ x $\frac{3}{4}$	1
14	18-441	Ball Joint	2
	HN-516-24	Hex Nut, $\frac{5}{16}$ - 24	4
15	76-634	LH Brake Rod	1
	HP-18-075	Cotter Pin, $\frac{1}{8}$ x $\frac{3}{4}$	1
16	76-595	LH Brake Lever	1
17	34-122	Short Elbow	4
18	76-541	Hydraulic Tube Assembly	1
19	34-057	Tee Fitting	2
20	20-656	Hydraulic Tube Assembly	3
21	76-542	LH Wheel Motor	1
	45-065-01	Studs	4
22	76-616	Rear Axle	1
23	HN-38-16	Hex Nut, $\frac{3}{8}$ - 16	4
24	75-723	Rear Skid	2
25	HHP-18	Bridge Pin, $\frac{1}{8}$	2
26	50-081	Rubber Bumper	2
27	HB-12-13-750	Hex Bolt, $\frac{1}{2}$ - 13 x $7\frac{1}{2}$	8
	HMB-12-14	Machine Bushing, $\frac{1}{2}$ x 14GA	8
	HNFL-12-13	Flange Whiz-loc Nut, $\frac{1}{2}$ - 13	8
28	HCP-12-225	Clevis Pin, $\frac{1}{2}$ x $2\frac{1}{4}$	2
	HHP-18	Bridge Pin, $\frac{1}{8}$	2
29	76-543	RH Wheel Motor	1
	45-065-01	Studs	4
30	HNL-12-20	Lug Nut, $\frac{1}{2}$ - 20	10
31	76-756	Rear Tire and Wheel	2
	16-225-01	Tire, 24 x 13.00 x 12 4-ply	2
	76-756-02	Rim	2
32	76-594	RH Brake Lever	1
33	HB-12-13-450	Hex Bolt, $\frac{1}{2}$ - 13 x $4\frac{1}{2}$	4
	HW-12	Flat Washer, $\frac{1}{2}$	2
	HNTL-12-13	Nylon Lock Nut, $\frac{1}{2}$ - 13	4
34	76-229	Park Brake Relay	1
35	76-635	RH Brake Rod	1
	HP-18-075	Cotter Pin, $\frac{1}{8}$ x $\frac{3}{4}$	1
36	76-639	Axle Shim	2

FINGER/BRUSH REEL DRAWING

PARTS

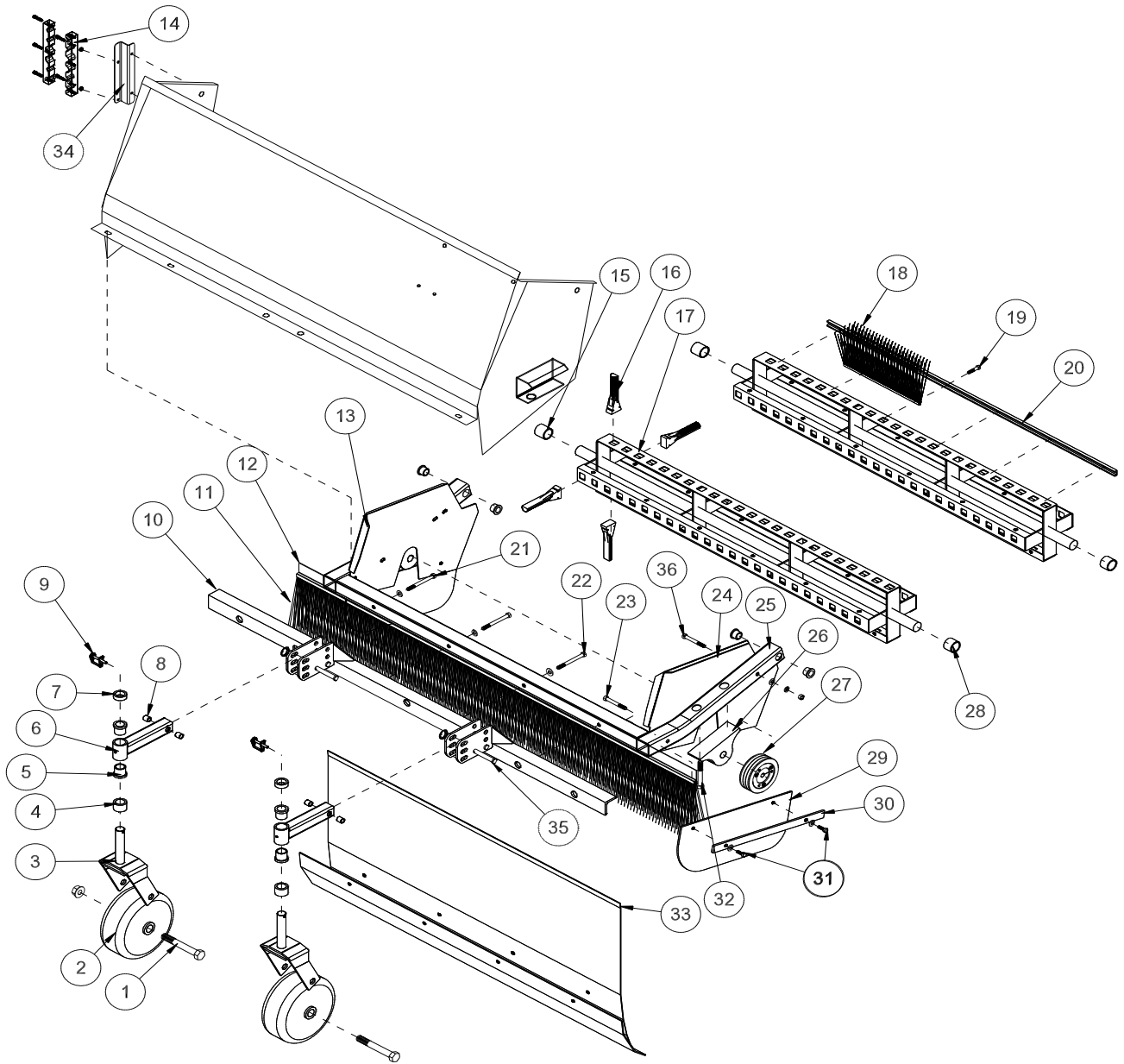

FINGER /BRUSH REEL PARTS LIST

REF#	PART#	DESCRIPTION	QUANTITY
1	HB-34-10-550	Hex Bolt, $\frac{3}{4}$ - 10 x $5\frac{1}{2}$	2
	HNTL-34-10	Nylon Lock Nut, $\frac{3}{4}$ - 10	2
2	33-435	Tire and Wheel	2
	33-435-02	Wheel with Roller Bearing	
	33-435-03	Roller Bearing	
	33-435-04	Bushing	
3	48-046	Castor Fork	2
	HMB-100-10	Machine Bushing 1 x 10GA	8
4	29-585	Spacer Height Adjustment	2
5	18-223	Bushing (part of 76-355)	2 per
6	76-355	Arm	2
7	29-584	Height Adjustment Spacer, $\frac{1}{2}$ "	2
8	20-019	Bushing (part of 76-355)	2 per
9	29-541	Lock Pin, $\frac{1}{4}$	2
10	76-356	Castor Mount Bracket	1
11	76-439	Brush	1
12	76-438	Brush Channel	1
13	75-799	Side Plate RH.	1
14	76-336	Hose Clamp	1
15	75-686	Spacer, $1\frac{1}{4}$ ID x $1\frac{3}{8}$	1
16	75-506	Sweeper Finger	116
17	75-780	Finger Reel	1
18	76-330	Brush	4
19	HB-516-18-125	Hex Bolt, $\frac{5}{16}$ - 18 x $1\frac{1}{4}$	28
	HNTL-516-18	Nylon Lock Nut, $\frac{5}{16}$ - 18	28
20	76-313	Clamp	4
21	HB-38-16-350	Hex Bolt, $\frac{3}{8}$ - 16 x $3\frac{1}{2}$	2
	HW-38	Flat Washer, $\frac{3}{8}$	4
	HNTL-38-16	Nylon Lock Nut, $\frac{3}{8}$ - 16	2
22	HB-38-16-400	Hex Bolt, $\frac{3}{8}$ - 16 x 4	1
	HW-38	Flat Washer, $\frac{3}{8}$	2
	HNTL-38-16	Nylon Lock Nut, $\frac{3}{8}$ - 16	1
23	HB-38-16-275	Hex Bolt, $\frac{3}{8}$ - 16 x $2\frac{3}{4}$	3
	HW-38	Flat Washer, $\frac{3}{8}$	7
	HNTL-38-16	Nylon Lock Nut, $\frac{3}{8}$ - 16	4
24	75-800	Left Side Plate	1
25	75-787	Reel Frame	1
	18-221	Flange Bushing (part of 75-787)	4
26	75-511	Pillow Block, $1\frac{1}{4}$ Bore	2
27	78-425	Pulley, 3-Groove	1
28	75-834	Spacer, $1\frac{1}{4}$ ID x $1\frac{1}{8}$	1
29	76-210	Matting $7\frac{1}{2}$ x 18	2
30	76-213	Reel Guard Strap	2
31	HB-516-18-100	Hex Bolt, $\frac{5}{16}$ - 18 x 1	4
	HNTL-516-18	Nylon Lock Nut, $\frac{5}{16}$ - 18	4
32	HB-12-13-350	Hex Bolt, $\frac{1}{2}$ - 13 x $3\frac{1}{2}$	4
	HMB-12-14	Machine Bushing, $\frac{1}{2}$ - 14	4
	HNTL-12-13	Nylon Lock Nut, $\frac{1}{2}$ - 13	4
33	75-808	Front Baffle	1
34	76-574	Hose Clamp Mount	1
35	HCP-12-250	Clevis Pin, $\frac{1}{2}$ x $2\frac{1}{2}$	4
	76-483	Knock-Out Ring	4
36	HB-38-16-300	Hex Bolt, $\frac{3}{8}$ - 16 x 3	1
	HW-38	Flat Washer, $\frac{3}{8}$	2
	HNTL-38-16	Nylon Lock Nut, $\frac{3}{8}$ - 16	1

HOPPER LIFT CYLINDER DRAWING

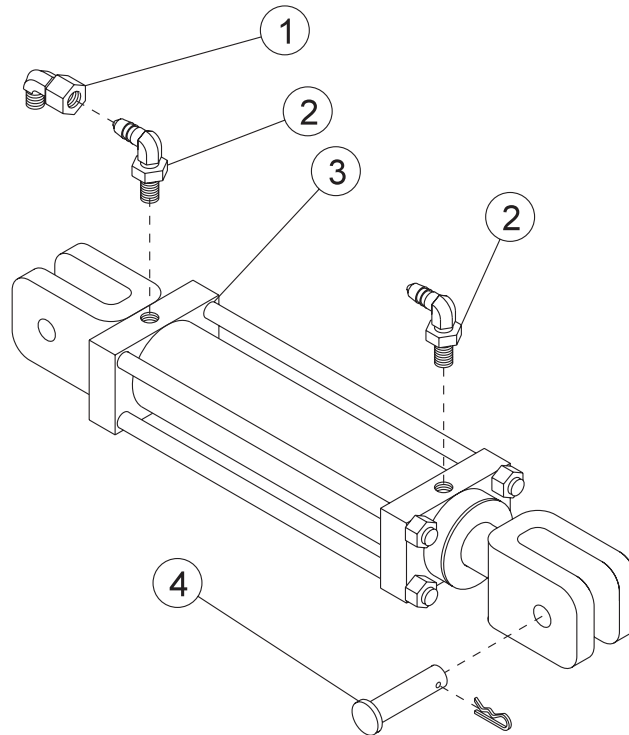

PARTS

REF#	PART#	DESCRIPTION	QUANTITY
1	18-202	Elbow	1
2	23-167	Elbow	2
3	76-627	Hydraulic Cylinder	1
	76-242-01	Seal Kit	1
4	HCP-100-325	Clevis Pin, 1 x 3 ¹ / ₄	2
	HHP-.177	Bridge Pin, .177 x 3 ³ / ₄	2

2 Cylinder Assemblies per Machine

TORQUE SPECIFICATION

PISTON NUT.....	165 FT/LBS (214.5 NM)
TIE ROD NUT	30 FT/LBS (39 NM)
CLEVIS NUT	46 FT/LBS (59.8 NM)

REEL LIFT CYLINDER DRAWING

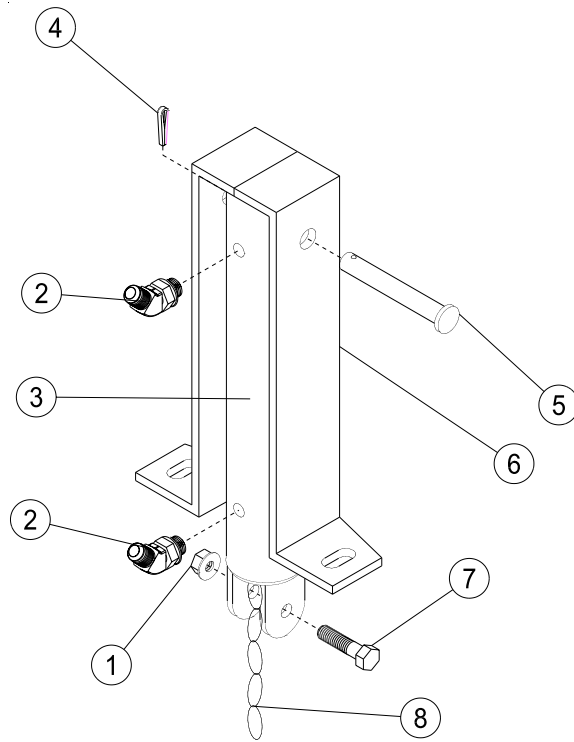

REF#	PART#	DESCRIPTION	QUANTITY
1	HNTL-38-16	Nylon Lock Nut, $\frac{3}{8}$ - 16	2
2	18-188	Elbow, $\frac{3}{8}$ SAE	2
3	76-478	Hydraulic Cylinder, 2 x 7 x $\frac{3}{4}$	1
4	14-531	Seal Kit	
4	HP-18-100	Cotter Pin, $\frac{1}{8}$ x 1	1
5	HCP-12-350	Clevis Pin, $\frac{1}{2}$ - 3 $\frac{1}{2}$	1
6	75-827	Cylinder Bracket	1
7	HB-38-16-150	Hex Bolt, $\frac{3}{8}$ - 16 x 1 $\frac{1}{2}$	1
8	8820-8	Machine Chain St. Link	1

HOPPER DRAWING

PARTS

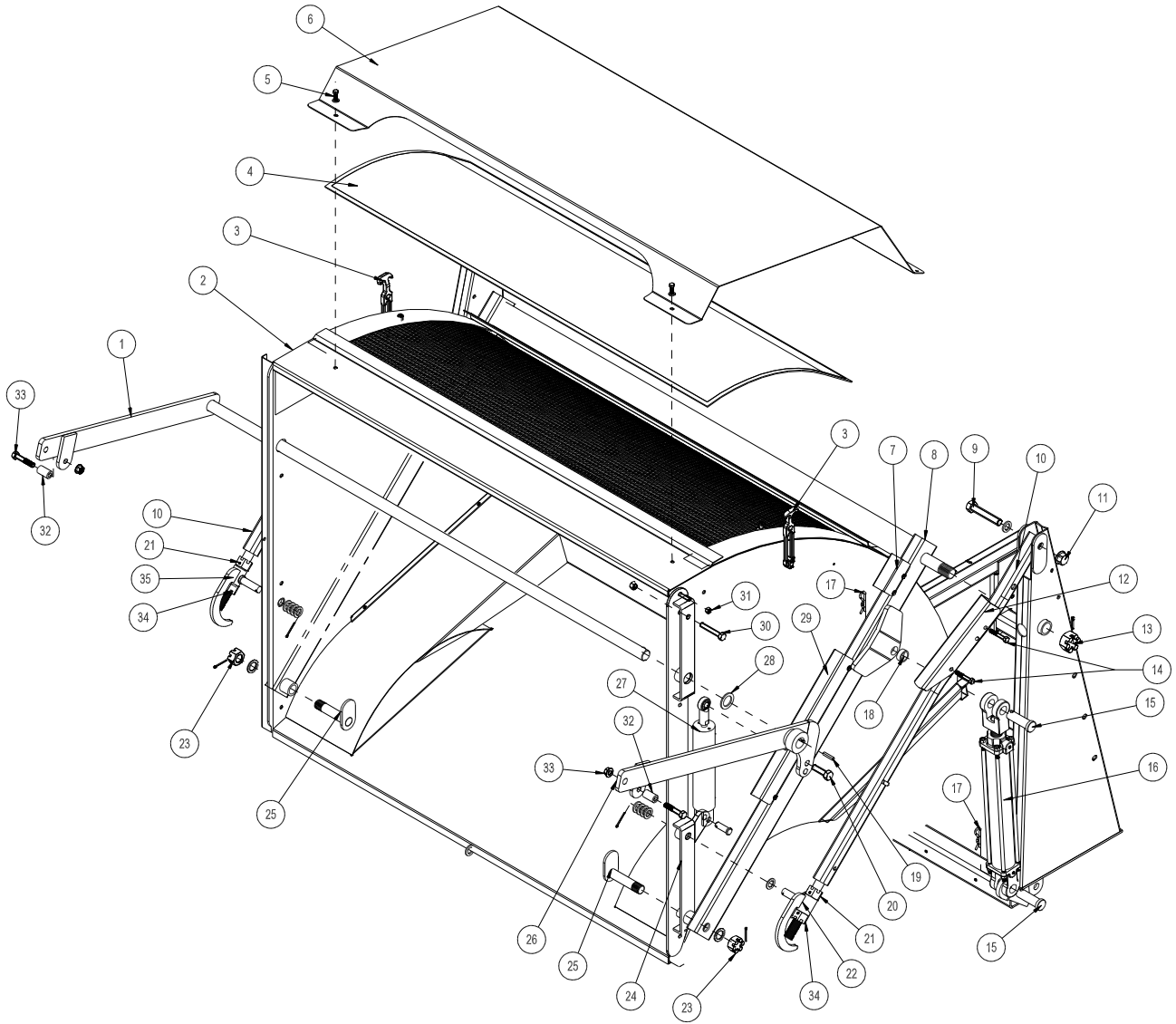

HOPPER PARTS LIST

REF#	PART#	DESCRIPTION	QUANTITY
1	76-414	Left Tailgate Dump Bar	1
2	76-237	Hopper	1
3	15-437	Latch	2
	HRS-316-1125	Rivet, $\frac{3}{16}$ x $1\frac{1}{8}$	4
	HRW-316	Rivet Washer, $\frac{3}{16}$	4
	HW-316	Washer, $\frac{3}{16}$	2
4	76-261	Hopper Screen	1
5	HB-516-18-075	Hex Bolt, $\frac{5}{16}$ - 18 x $\frac{3}{4}$	6
	HW-516	Flat Washer, $\frac{5}{16}$	6
	HNTL-516-18	Nylon Lock Nut, $\frac{5}{16}$ - 18	6
6	76-359	Hopper Screen Cover	1
7	76-161	Short Metal Hose Guard	1
8	76-211	Arm Pivot Tube	1
9	HB-34-10-400	Hex Bolt, $\frac{3}{4}$ - 10 x 4	2
	HMB-34-10	Machine Bushing, $\frac{3}{4}$ - 10GA	2
10	76-230	Hopper Dump Arm	2
11	HNTL-34-10	Nylon Lock Nut, $\frac{3}{4}$ - 10	2
12	75-653	Hopper Safety Lift	2
13	HNA-114-12	Axle Nut, $1\frac{1}{4}$ - 12	2
	HP-316-100	Cotter Pin, $\frac{3}{16}$ x 1	2
14	HB-38-16-225	Hex Bolt, $\frac{3}{8}$ - 16 x $2\frac{1}{4}$	4
	HNW-38-16	Wing Nut, $\frac{3}{8}$ - 16	4
15	HCP-100-325	Clevis Pin, 1 x $3\frac{1}{4}$	4
16	76-627	Hydraulic Cylinder	2
17	HHP-.177	Bridge Pin, .177 x $3\frac{3}{4}$	2
18*	76-288	Spacer	2
19	HKSQ-14-150	Machine Key, $\frac{1}{4}$ x $\frac{1}{4}$ x $1\frac{1}{2}$	1
	HSSHS-516-18-038	Set Screw, $\frac{5}{16}$ - 18 x $\frac{3}{8}$	1
	HRP-38-250	Roll Pin, $\frac{3}{8}$ x $2\frac{1}{2}$	1
20	HB-58-11-200	Hex Bolt, $\frac{5}{8}$ - 11 x 2	1
	HMB-58-14	Machine Bushing, $\frac{5}{8}$ x 14GA	3
	HNCL-58-11	Center Nylon Lock Nut, $\frac{5}{8}$ - 11	1
21	HNA-100-14	Slotted Hex Nut, 1 - 14	2
22	48-148	Right Adjustment Sleeve	1
	HMB-34-14	Machine Bushing, $\frac{3}{4}$ x 14GA	1
	HMB-34-10	Machine Bushing, $\frac{3}{4}$ x 10GA	4
	HP-18-150	Cotter Pin, $\frac{1}{8}$ x $1\frac{1}{2}$	1
23	HMB-100-14	Machine Bushing, 1 x 14GA	2
	HNA-100-14	Slotted Hex Nut, 1 - 14	2
	HP-18-150	Cotter Pin, $\frac{1}{8}$ x $1\frac{1}{2}$	2
24	76-215	Right Hinge Strap (Shown)	1
	76-216	Left Hinge Strap	1
25	75-569	Swivel Pin	2
26	76-413	Right Tailgate Dump Bar	1

*Spacer **MUST** be to the outside of the tab on the Pivot Arm with the tab and the spacer inside the cylinder yoke.

(Continued on next page)

HOPPER DRAWING

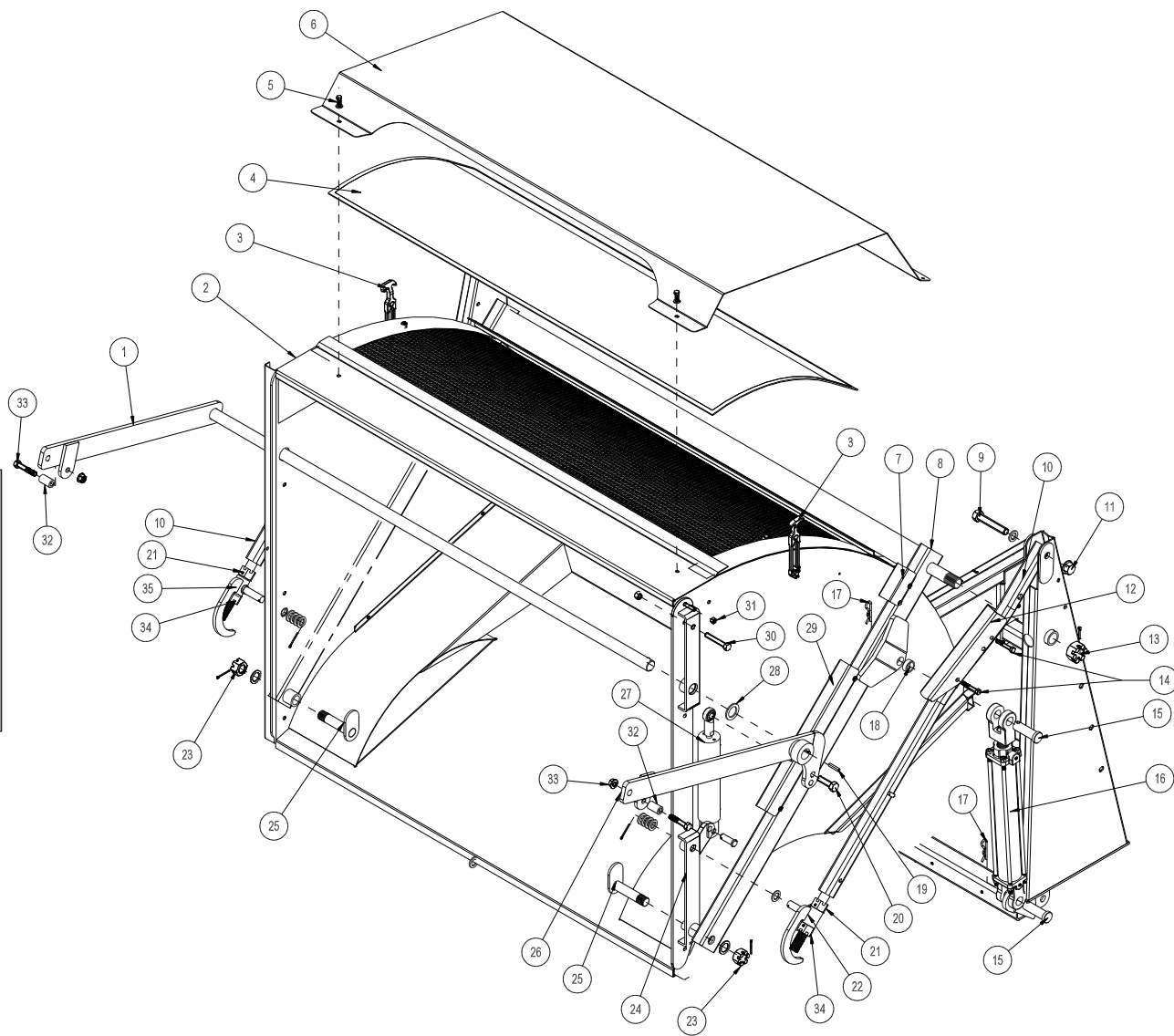

PARTS

HOPPER PARTS LIST

REF#	PART#	DESCRIPTION	QUANTITY
27	15-839	Hydraulic Cylinder	1
	18-168	Elbow	2
	18-154	Rod End	1
	HG-14-28-180	Grease Fitting, 1/4 - 28 x 180° (part of rod end)	1
	HCP-58-175	Clevis Pin, 5/8 x 1 3/4	1
	HHP-18	Bridge Pin, 1/8	1
28	HMB-114-10	Machine Bushing, 1 1/4 x 10 GA	2 As Req'd
29	76-159	Hose Guard, Long	1
30	HB-12-13-300	Hex Bolt, 1/2 - 13 x 3	2
	HN-12-13	Hex Nut, 1/2 - 13	2
	HNCL-12-13	Center Nylon Lock Nut, 1/2 - 13	2
31	HNCL-38-16	Center Nylon Lock Nut, 3/8 - 16	8
	HB-38-16-100	Hex Bolt, 3/8 - 16 x 1	8
32	42-702	Spacer	2
33	HB-12-13-250	Hex Bolt, 1/2 - 13 x 2 1/2	2
	HNCL-12-13	Center Nylon Lock Nut, 1/2 - 13	2
34	75-704	Castle Nut, 1 - 14	2
	HSSHS-38-16-038	Set Screw, 3/8 - 16 x 3/8	2
35	48-153	Left Adjustment Sleeve	1
	HMB-34-14	Machine Bushing, 3/4 x 14GA	1
	HMB-34-10	Machine Bushing, 3/4 x 10GA	4
	HP-18-150	Cotter Pin, 1/8 x 1 1/2	1

TAILGATE DRAWING

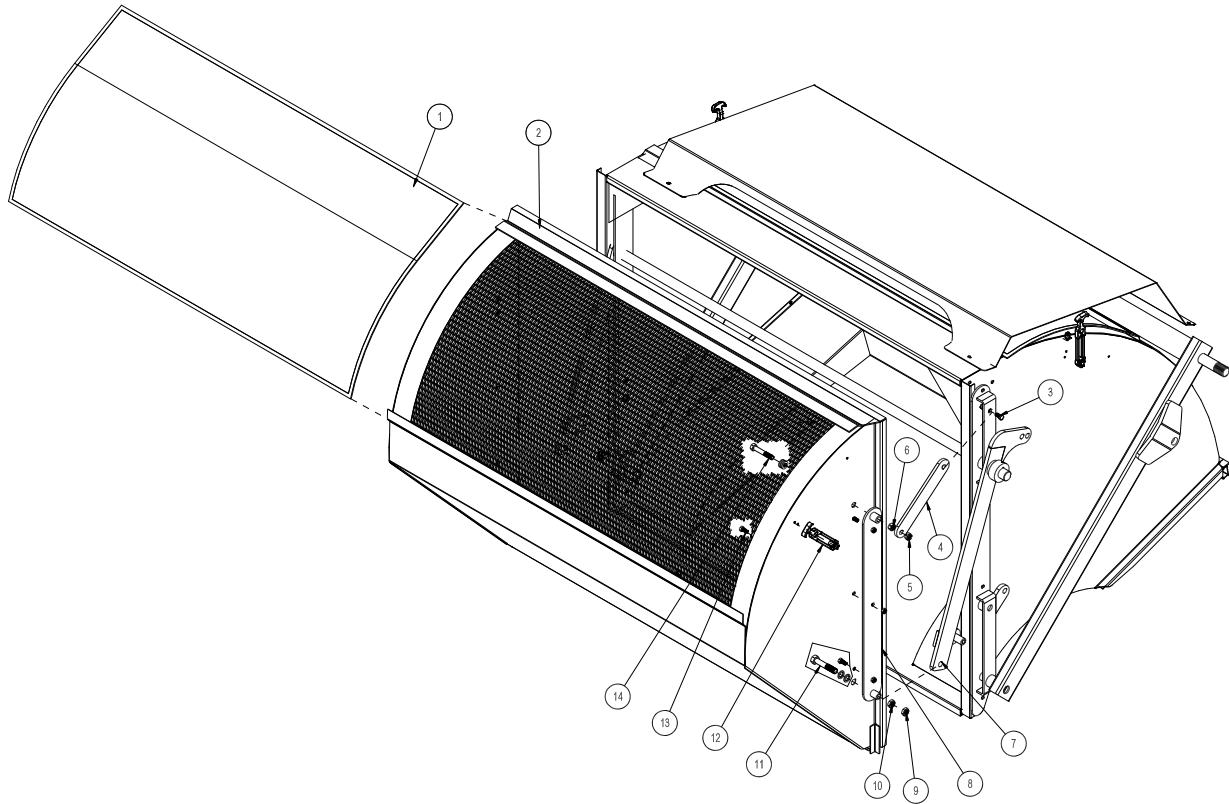

Parts

REF#	PART#	DESCRIPTION	QUANTITY
1	76-262	Tailgate Screen	1
2	76-243	Tailgate	1
3	HB-12-13-300	Hex Bolt, 1/2 - 13 x 3	2
	HN-12-13	Hex Nut, 1/2 - 13	2
	HNCL-12-13	Center Nylon Lock Nut, 1/2 - 13	2
4	75-564	Tailgate Hinge	2
5	HNCL-12-13	Center Nylon Lock Nut, 1/2 - 13	2
6	HN-12-13	Hex Nut, 1/2 - 13	2
7	76-413	Right Tailgate Dump Bar	1
8	75-565	Tailgate Hinge Strap	2
9	HNCL-58-11	Center Nylon Lock Nut, 5/8 - 11	2
10	HNJ-58-18	Jam Nut, 5/8 - 18	2
11	HB-58-18-325	Hex Bolt, 5/8 - 18 x 3 1/4	2
	HMB-58-14	Machine Bushing, 5/8 x 14GA	10
12	15-437	Latch	2
	HRS-316-1125	Rivet, 3/16 x 1 1/8	2
	HRS-316-100	Rivet, 3/16 x 1	4
	HRW-316	Rivet Washer, 3/16	4
	HW-316	Flat Washer, 3/16	2
13	HNCL-38-16	Center Nylon Lock Nut, 3/8 - 16	6
	HB-38-16-100	Hex Bolt, 3/8 - 16 x 1	6
14	HB-12-13-300	Hex Bolt, 1/2 - 13 x 3	2
	HMB-12-14	Machine Bushing, 1/2 x 14GA	6

TAILGATE CYLINDER DRAWING

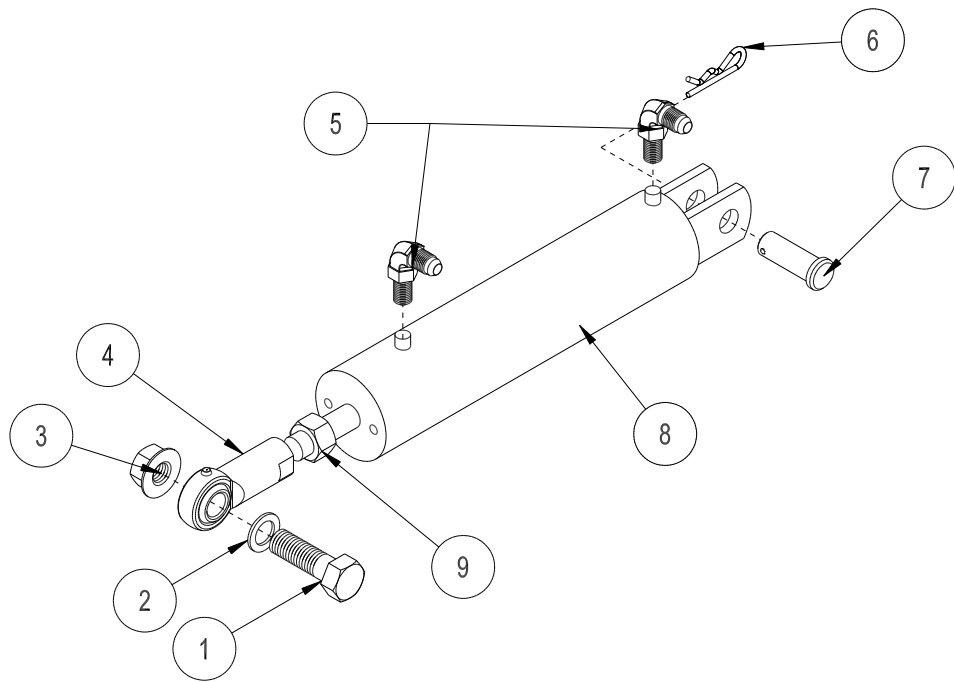

REF#	PART#	DESCRIPTION	QUANTITY
1	HB-58-11-200	Hex Bolt, $\frac{5}{8}$ - 11 x 2	1
2	HMB-58-14	Machine Bushing, $\frac{5}{8}$ - 14GA	1
3	HNTL-58-11	Nylon Lock Nut, $\frac{5}{8}$ - 11GA	1
4	18-154	Rod End	1
	HG-14-28-180	Grease Fitting, $\frac{1}{4}$ - 28 x 180°	1
5	18-168	Elbow	2
6	HHP-18	Bridge Pin, $\frac{1}{8}$	1
7	HCP-58-175	Clevis Pin, $\frac{5}{8}$ x $1\frac{3}{4}$	1
8	15-839	Hydraulic Cylinder	1
	15-839-01	Seal Kit	1
9	HNJ-58-18	Jam Nut, $\frac{5}{8}$ - 18	1

Parts

76-638 HYDROSTATIC PUMP DRAWING

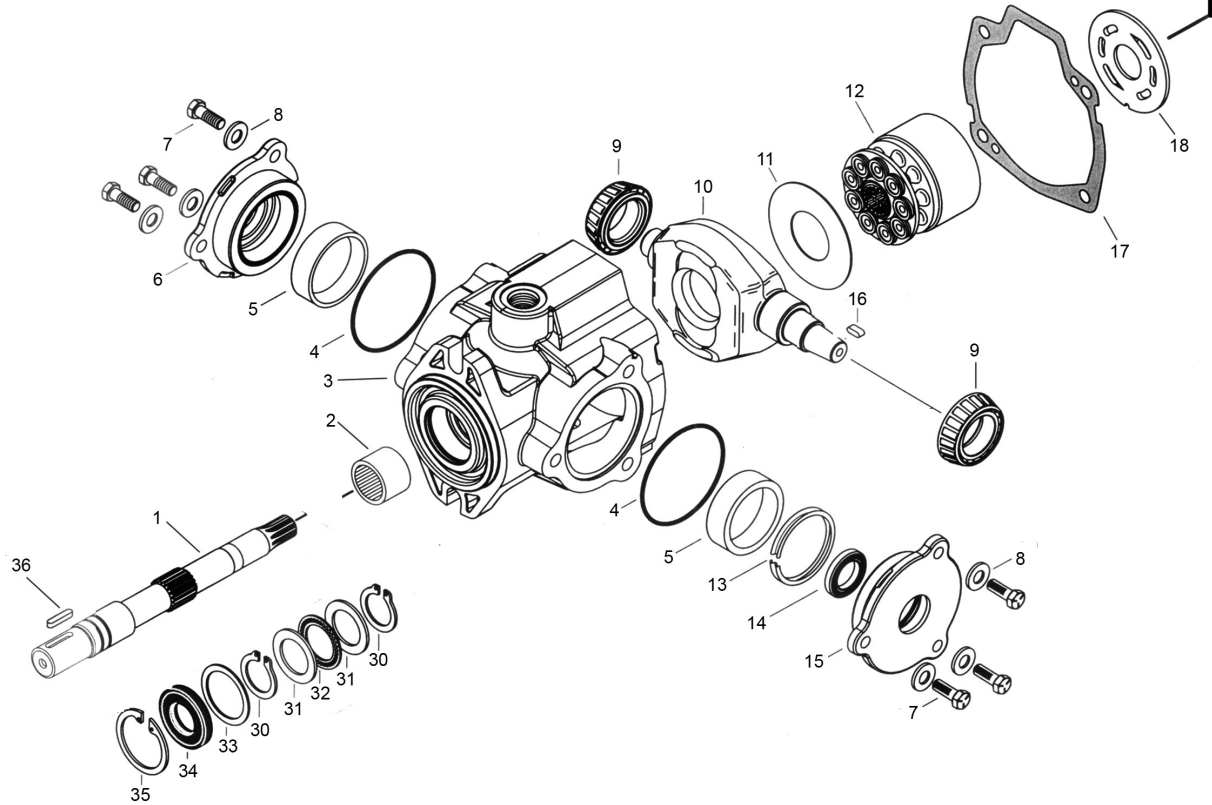
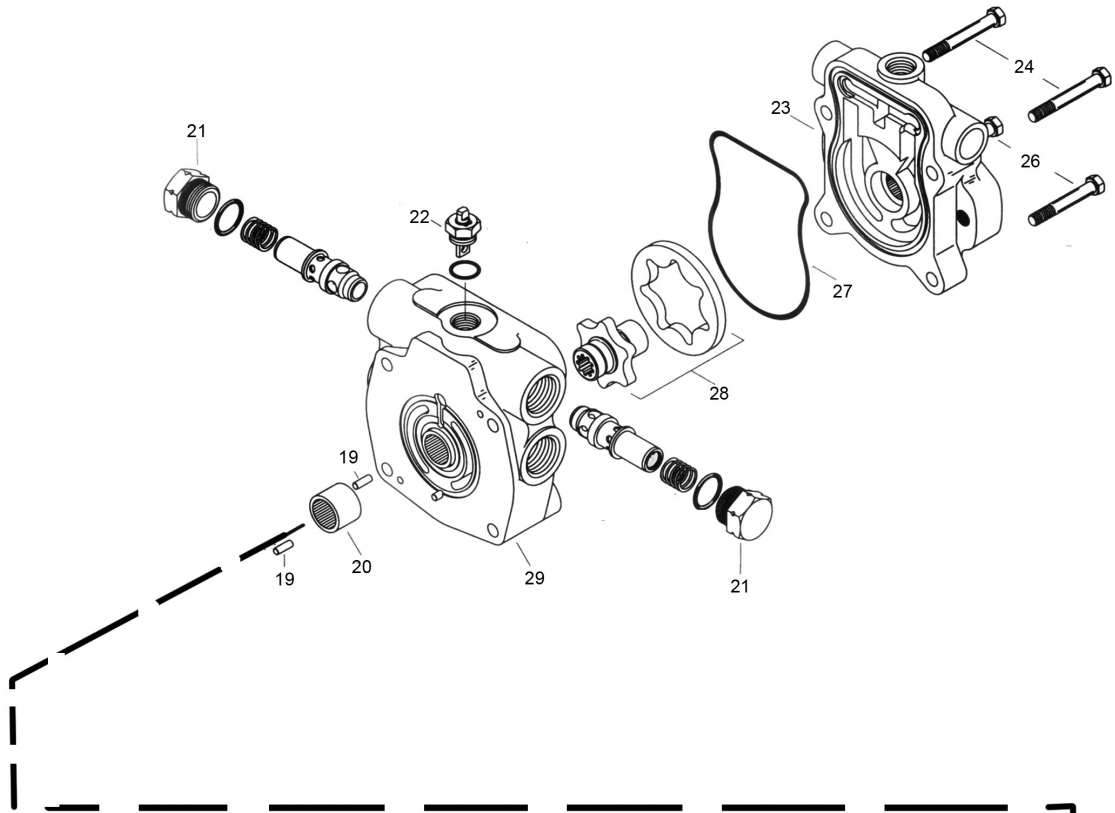

Parts

76-638 HYDROSTATIC PUMP PARTS LIST

REF#	PART#	DESCRIPTION	QUANTITY
1	76-398-01	Drive Shaft (splined)	1
2		Needle Bearing (with housing)	1
3	77-239-01	Housing	1
4	77-239-02	O-Ring	1
5	77-239-03	Thrust Bearing	2
6	77-239-04	Trunnion Cover	1
7	77-239-05	Pan Head Screw	2
8	77-239-06	Washer	6
9	77-239-07	Cone Bearing	2
10	77-239-08	Cam Plate	1
11	77-239-09	Swash Plate Insert	1
12	60-343-21	Rotating Kit	1
13	77-239-10	Crush Ring	1
14*	60-343-12	Shaft Seal	1
15	77-239-11	Seal Cover	1
16		Key	1
17*	77-239-13	Gasket	1
18	76-482-01	Back Plate	1
19		Dowel Pin	2
20		Bearing	1
21	77-239-15	Relief Valve	2
22	77-239-16	Tow Valve Assembly	1
23		Charge Pump Adaptor	1
24	77-239-17	Cap Screw	2
26	77-239-18	Cap Screw	2
27*	77-239-19	O-Ring	1
28	60-343-43	Gerotor and Coupler	1
29		End Cover Assembly	1
30*	77-239-21	Retaining Ring	2
31	60-343-05	Bearing Race	1
32	60-343-06	Thrust Bearing	1
33	60-343-03	Washer	2
34*	60-343-02	Shaft Seal	1
35*	60-343-01	Retaining Ring	1
36	60-343-49	Key	1
* 	77-239-23	Seal Repair Kit	

76-539 MOTOR DRAWING

Service

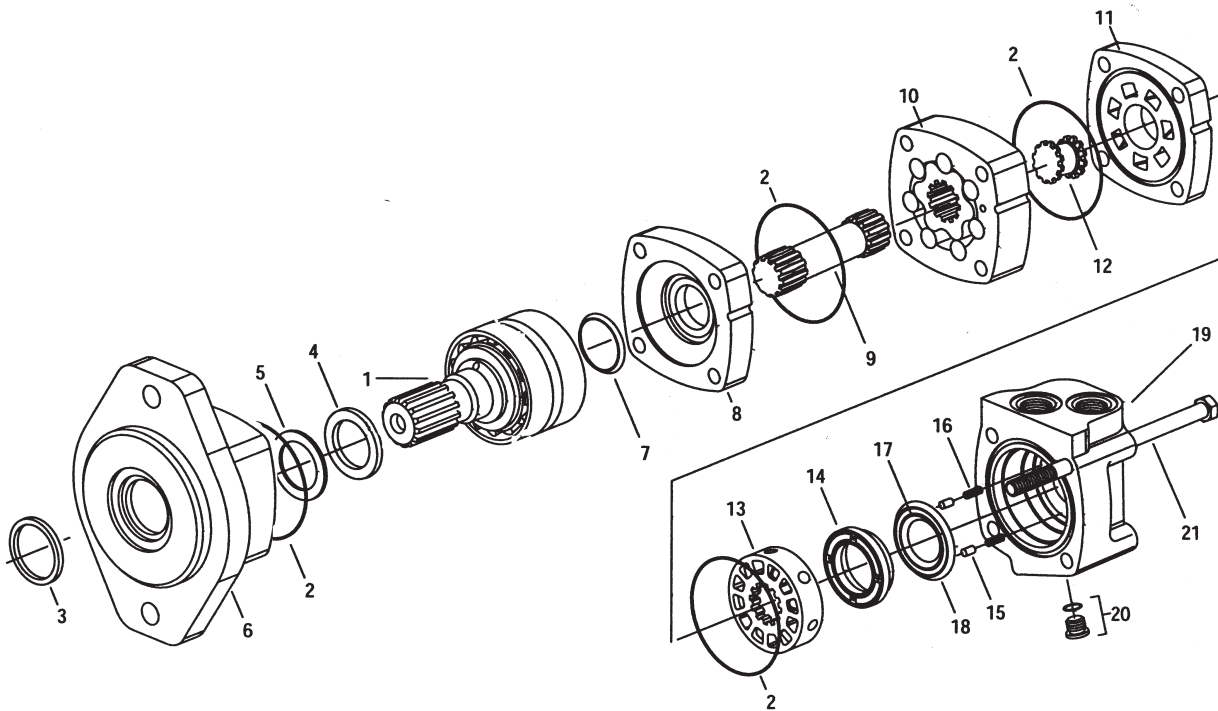

REF#	PART#	DESCRIPTION	QUANTITY
1	76-539-01	Shaft and Bearing Kit	1
2*		Seal	4
3*		Exclusion Seal	1
4*		Shaft Seal	1
5*		Back-up Ring	1
6	76-539-02	Bearing Housing SAE A	1
7*		Shaft Face Seal	1
8	30-101-03	Wear Plate	1
9	76-539-03	Main Drive	1
10	76-539-04	Geroler	1
11	30-101-06	Valve Plate	1
12	14-207	Valve Drive	1
13	14-208	Valve	1
14	30-101-07	Balance Ring	1
15	14-210	Balance Ring Pin	2
16	14-209	Compression Spring	2
17*		Inner Face Seal	1
18*		Outer Face Seal	1
19	30-101-08	Valve Housing	1
20	30-101-09	Plug Assembly	1
*		O-ring	1
21	76-539-05	Cap Screw	4
*	30-101-11	Seal Kit	1

76-559 POWER STEERING DRAWING

Service

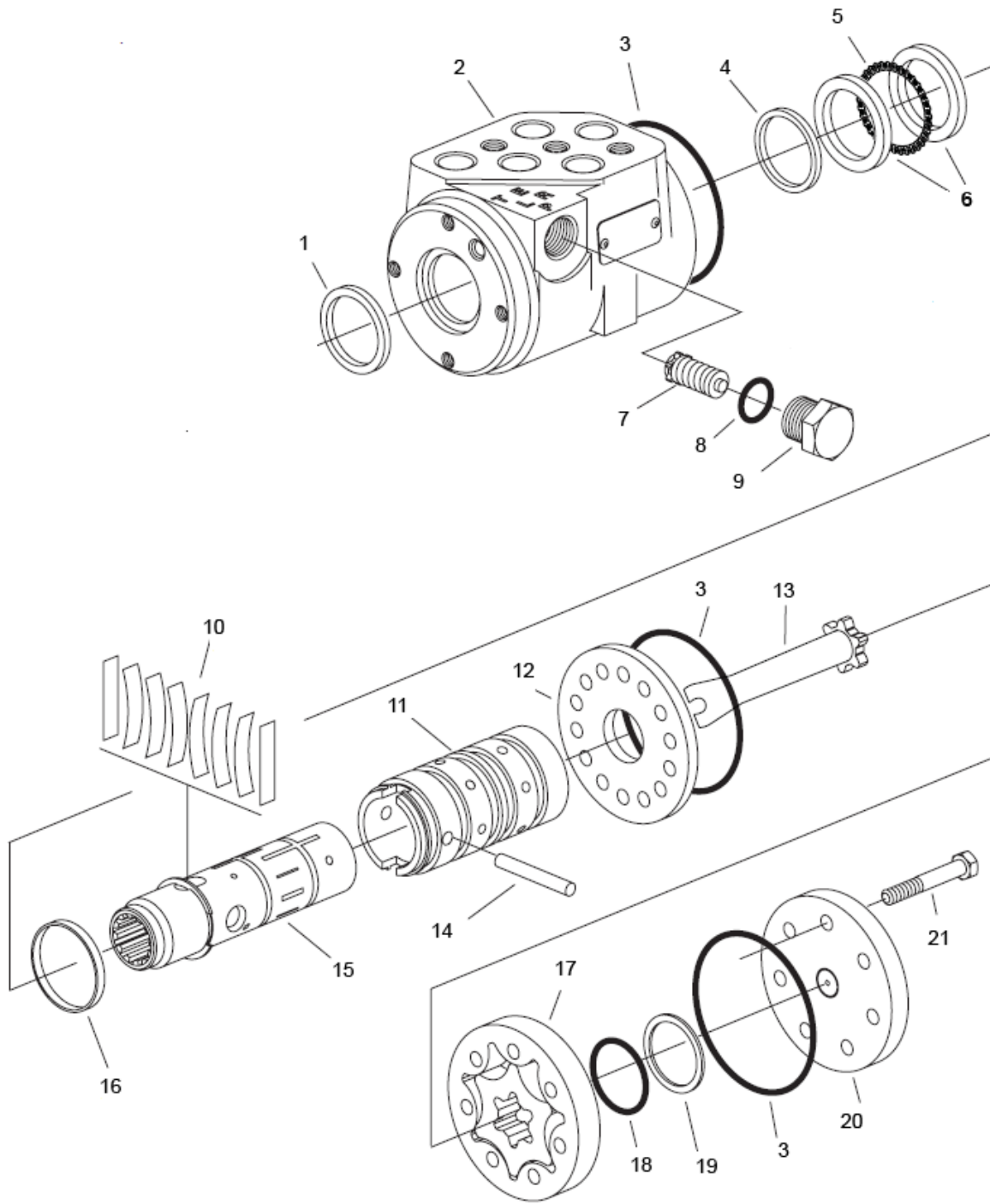

76-559 POWER STEERING PARTS LIST

REF#	PART#	DESCRIPTION	QUANTITY
1	10-576-04	Dust Seal	1
2		Housing	1
3**		O-Ring Seal	3
4**		Quad Seal	1
5	10-576-03	Thrust Bearing	1
6	10-576-02	Bearing Race	2
7		Manual Steering Relief Valve	1
8**		O-ring	1
9		Plug	1
10‡		Standard Torque Centering Springs	1
11		Sleeve	1
12	15-301-06	Wear Plate	1
13	10-576-01	Drive	1
14	15-301-08	Drive Pin	1
15		Spool	1
16‡		Spring Retaining Ring	1
17	76-559-01	Gerotor	1
18**		O-Ring	1
19**		Seal Ring	1
20	15-301-03	End Cap	1
21	76-559-02	Cap Screw	7
**	15-301-01	Seal Kit	1
‡	15-301-15	Centering Spring Kit	1

76-559 ORBITROL SPECIFICATIONS

Inlet Relief Valve Setting	1020 psi (70 bar)
Nominal Flow	3 gpm (11 lpm)
Displacement	6.10 cu. in/ R (100 cu cm/R)
Check Valve for Manual Steering	Yes
Inlet Pressure Rating	2030 psi (140 bar)
Return Pressure Rating	145 psi (10 bar) Maximum
Fluid	SAE 10W-40 API Service SJ or higher Motor Oil
Ports	9/16 - 18 SAE O-Ring 4 Ports

76-751 DUST/DIRT FILTRATION SYSTEM

Service

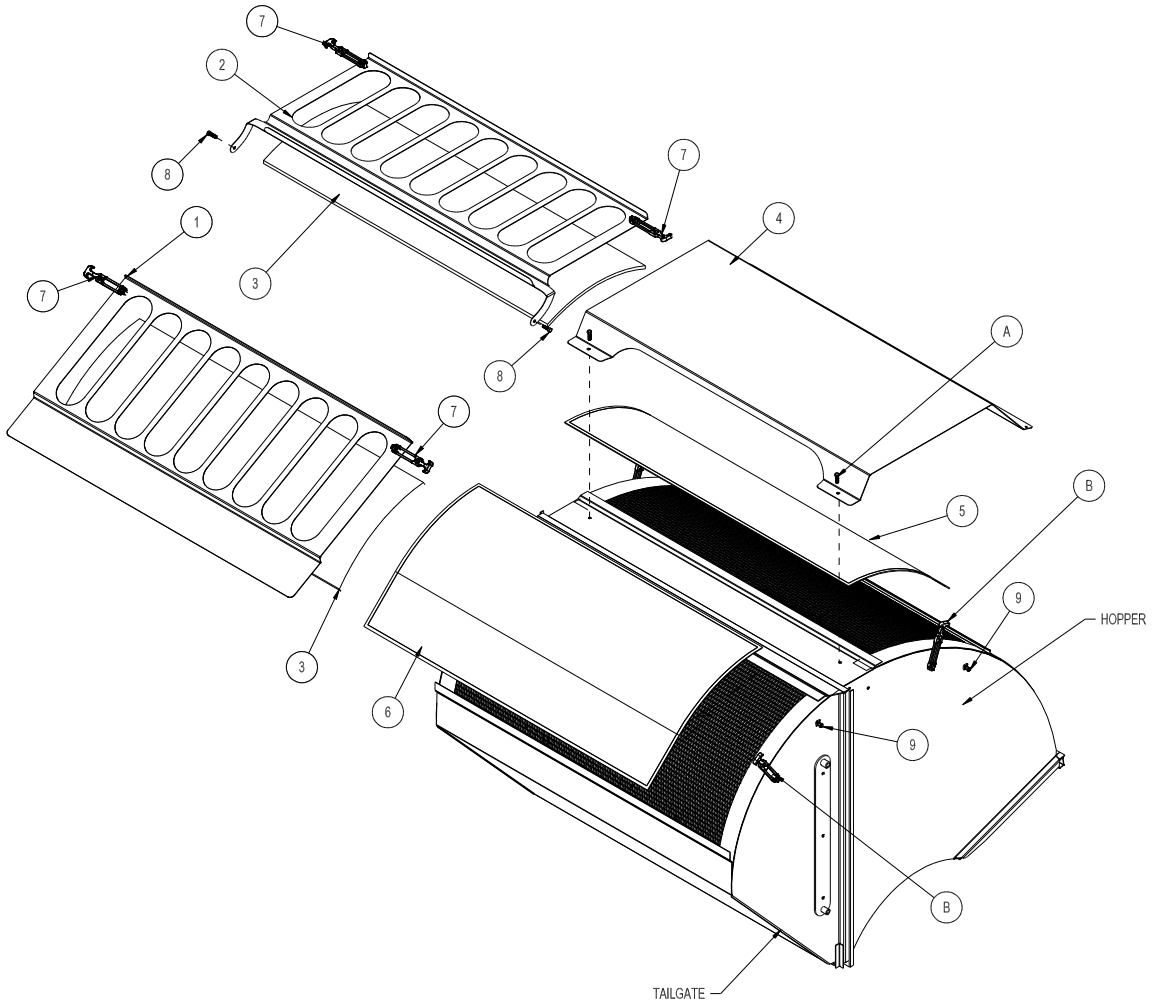

76-751 DUST/DIRT FILTRATION SYSTEM

REF#	PART#	DESCRIPTION	QUANTITY
1	76-622	Tailgate Screen Cover	1
2	76-623	Top Filter Cover	1
3	76-624	Hog Hair Filter (20 x 58)	2
4	76-263	Hopper Screen Cover (Remove)	1
5	76-261	Hopper Screen (Remove)	1
6	76-262	Tailgate Screen (Remove)	1
7*	15-437-02	Latch	4
	HSM-10-32-100	Hex Bolt, #10 - 32 x 1	8
	HNFL-10-32	Flange Whiz-loc Nut, #10 - 32	8
8	HB-38-16-125	Hex Bolt, $\frac{3}{8}$ - 16 x $1\frac{1}{4}$	2
	HN-38-16	Hex Nut, $\frac{3}{8}$ - 16	2
	HNTL-38-16	Nylon Lock Nut, $\frac{3}{8}$ - 16	2
9*	15-437-01	Keeper	4
	HSM-10-32-100	Hex Bolt, #10 - 32 x 1	4
	HNFL-10-32	Flange Whiz-loc Nut, #10 - 32	4
*	15-437	Rubber Latch and Keeper	4
NS	8980-60	Trim Edge	1

Service

INSTALLATION INSTRUCTIONS

1. Release rubber latches (Ref B) holding tailgate screen in place.
2. Remove tailgate screen (Ref 6) from tailgate. Unwedge the top and lift out of the bottom tab.
3. Install latches (Ref 7) to both sides of the tailgate screen cover and keeper (Ref 9) to tailgate sides using #10-32 Hex Bolts and nuts on the bracket end.
4. First, place the hog hair blue filter (Ref 3) onto the tailgate screen, then place tailgate screen cover (Ref 1) over the top of the hog hair filter by placing the screen into the bottom tab and wedging it against the top of the tailgate. Then hook latches to keepers to hold in place.
5. Remove Hex Bolts (Ref A) holding the hopper screen cover (Ref 4) to hopper.
6. Remove the hopper screen (Ref 5) from the hopper by unwedging the top and pulling it out the bottom tab.
7. Place top filter cover (Ref 2) over the hopper screen opening. Secure with $\frac{3}{8}$ - 16 Hex Bolts, nuts and locknuts (Ref 8). Tighten locknut so top filter cover can still hinge on the Hex Bolts.
8. Install latches (Ref 7) onto the filter cover (Ref 2) and the keepers (Ref 9) to the sides of the hopper using the 10-32 Hex Bolts and nuts.
9. Install the 8980-60 trim edge onto the top of the hopper screen opening.
10. Place the hog hair filter (Ref 5) onto the hopper screen. Lower top filter cover and hook latches to the keepers.

76-754 FRENCH BRUSH REEL KIT

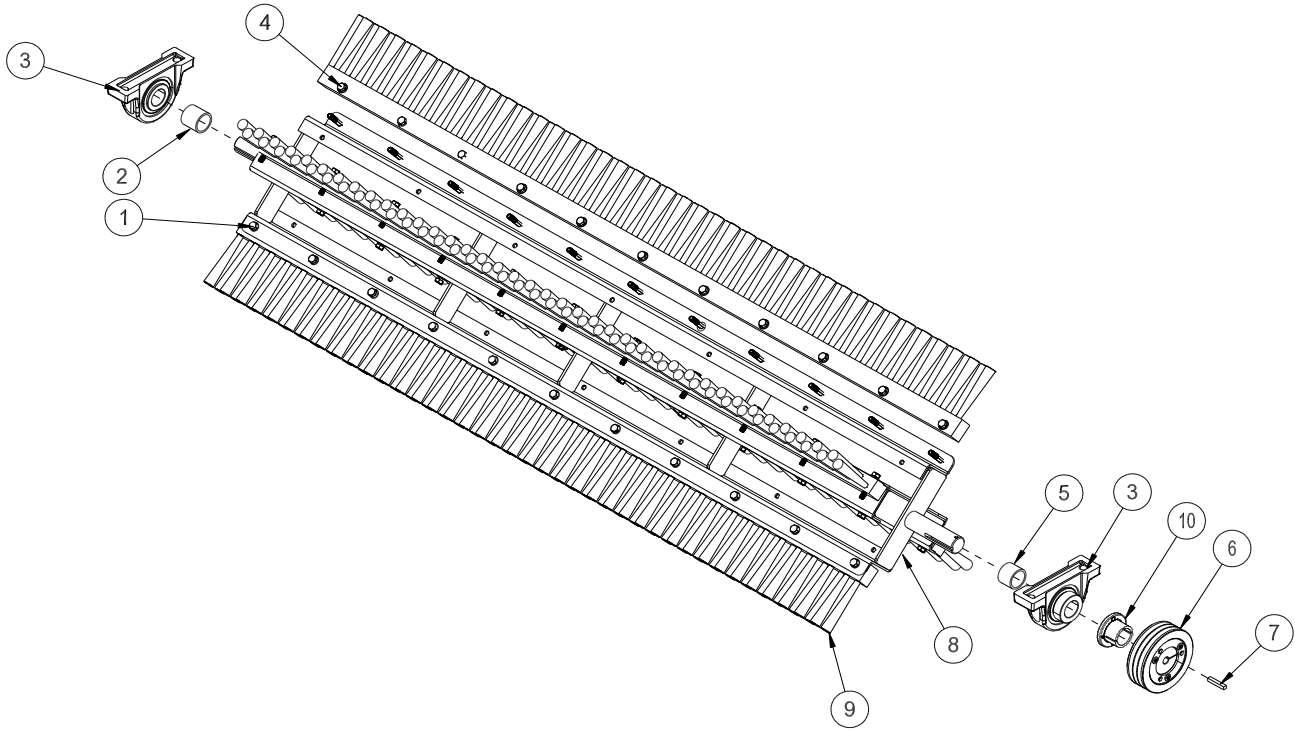

REF	PART#	DESCRIPTION	QUANTITY
1	HB-516-18-175	Hex Bolt, $\frac{5}{16}$ - 18 x $1\frac{3}{4}$	44
	HW-14	Flat Washer, $\frac{1}{4}$	44
2	75-686	Spacer	1
3	75-511	Pillow Block	2
4	HNTL-516-18	Nylon Lock Nut, $\frac{5}{16}$ - 18	44
5	75-834	Spacer	1
6	78-425	Pulley	1
7	HKSQ-14-150	Square Key, $\frac{1}{4}$ x $1\frac{1}{2}$	1
8	76-456	Brush Reel Frame	1
9	76-455	Brush	4
10	78-431	Hub	1

DECAL LIST

This is a list of decals located on the Sweep Star 60. Part number, description and location will help in reordering decals.

A	25-279 Decal, Safety Warning	Belt Guard
B	25-286 Decal, Pinch Point	Front & Back Belt Guard/R&L Hopper Bottom
C	25-298 Decal, Warning Hot	Fan Mount
D	25-307 Decal, Refuel w/ Gasoline	Manifold Mount (above gas tank)
E	25-320 Decal, Warning Load Limit	Left Front Hopper
F	25-355 Decal, Tire Pressure 18 PSI	Front Tires
G	25-355 Decal, Tire Pressure 18 PSI	Rear Tires
H	25-358 Decal, Smithco 12"	Front Dash Console
I	25-359 Decal, Smithco 17"	Rear Hopper
J	25-362 Decal, Fire Danger	Oil Tank Cover
L	25-373 Decal, 7" Smithco Star	Front Oil Tank
M	75-651 Decal, Hopper Lift Safety	Hopper Lift Safety Bar
N	76-304 Decal, Crush/Pinch	R&L Front Hopper
O	76-307 Decal, Tower Warning	R&L Hopper Tower
P	76-417 Decal, Sweep Star 60	R&L Hopper Side
Q	76-536 Decal, Control Panel	Dash Panel

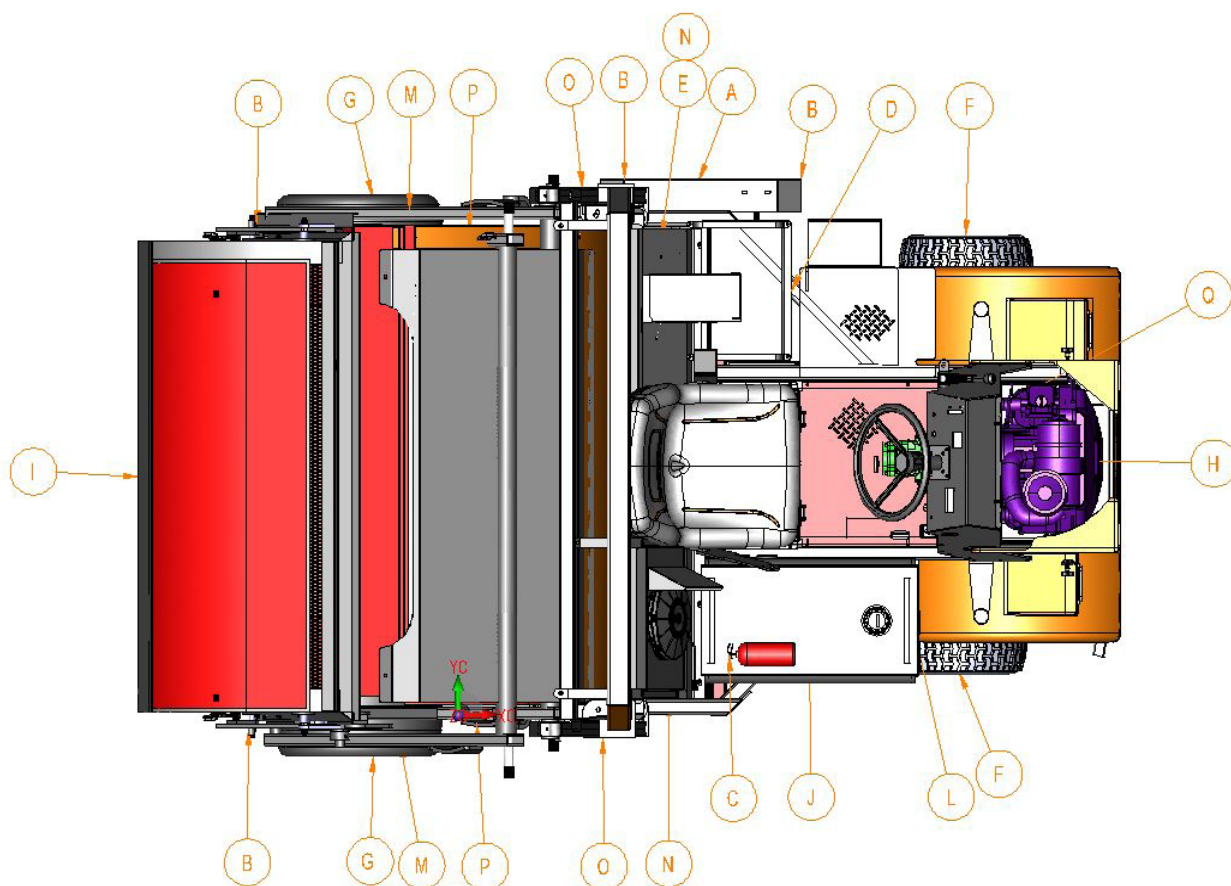

QUICK REFERENCE REPLACEMENT PARTS

REPLACEMENT FILTERS

60-334	Hydraulic Oil Filter Element	
13-531	Engine Oil filter	Briggs # 842921
76-395-01	Air Cleaner Cartridge	Briggs # 841497
76-395-02	Safety Filter Cartridge	Briggs # 821136
50-403	Fuel Filter	

REPLACEMENT BELTS

76-621	Belt, 3V x 590	3per
--------	----------------	------

SEAL KITS

76-559	Orbitrol	
15-301-01	Seal Kit	
76-638	Hydrostatic Pump	
77-239-23	Seal Kit	
76-539	Reel Motor	
30-101-11	Seal Kit	
76-540	Gear Pump	
76-540-01	Seal Kit	
76-543	RH Wheel Motor	
14-080	Seal Kit	
43-241-01	Replacement Brake	
76-542	LH Wheel Motor	
14-080	Seal Kit	
43-241-01	Replacement Brake	
76-627	Hydraulic Cylinder (Hopper)	
76-242-01	Seal Kit	
15-839	Hydraulic Cylinder (Tailgate & Steering)	
15-839-01	Seal Kit	
76-478	Hydraulic Cylinder (Reel)	
14-531	Seal Kit	

FLUIDS

Engine Oil	SJ or Higher	10W-30
Hydraulic Fluid	SJ or Higher	10W-40

OTHER PARTS

13-488	Key Switch
76-354	2 ¹ / ₂ # ABC Dry Chemical Fire Extinguisher

The Smithco Commercial Products Two-Year Limited Warranty

Smithco, Inc. (Smithco) warrants your 2016 or newer Smithco Commercial Product (“Product”) purchased after October 1, 2016 to be free from defects in materials or workmanship for the period of time listed below. Where a warrantable condition exists, Smithco will repair the Product at no cost to you including diagnosis, labor (at the Smithco standard labor rate, subject to the Smithco flat rate schedule), and parts.

Warranty Duration is:

- (1) Two years, 1500 operational hours* from the date of delivery to the original purchaser or Five years from the date of original manufacturer of the product, whichever occurs first. (*Products equipped with hour meter).
- (2) Products used in rental situations are covered for 90 days from date of delivery to original user/renter.

Owner Responsibilities:

As the Product owner, you are responsible for required maintenance and adjustments stated in your Owner’s Manual. Failure to perform required maintenance and adjustments can be grounds for disallowing a warranty claim. **You are particularly responsible to train all present and future operators of this product on the safe operation of this product at your location.**

Instructions for Obtaining Warranty Service:

You are responsible for notifying the Authorized Smithco Products Distributor from whom you purchased the Product as soon as you believe a warrantable condition exists and not later than 30 days from discovery of the condition.

If you need help locating an Authorized Smithco Distributor, or if you have questions regarding your warranty rights or responsibilities, you may contact us at:

Smithco Product Support Department
200 West Poplar Ave.
Cameron, Wisconsin 54822
Telephone: 800-891-9435 E-Mail: ProductSupport@Smithco.com

Maintenance Parts:

Parts scheduled for replacement as required maintenance (“Maintenance Parts”), are warranted for the period of time up to the scheduled replacement time for that part.

Items/Conditions Not Covered:

Not all product failures or malfunctions that occur during the warranty period are defects in materials or workmanship. The items/conditions listed below are not covered by this warranty:



Product failures which result from the use of non-Smithco replacement parts, or from installation and use of add-on, modified, or unapproved accessories are not covered.



Product failures which result from failure to perform required maintenance and/or adjustments are not covered.



Product failures that result from operating the Product in an abusive, negligent or reckless manner are not covered.



This warranty does not apply to parts subject to consumption through use, unless found to be defective. Examples of parts which are consumed, or used up, during normal Product operation include, but are not limited to: blades, tines, teeth, scarifiers, rakes, plates, wear plates, castor wheels, tires, batteries, filters, belts, nozzles, etc.



This warranty does not apply to failures caused by outside influence. Items considered to be outside influence include, but are not limited to, weather, storage practices, contamination, use of unapproved coolants, lubricants, additives, or chemicals, etc.



This warranty does not apply to normal “wear and tear” items. Normal “Wear and Tear” includes, but is not limited to, damage to seats due to wear or abrasion, worn painted surfaces, scratched decals or windows, etc.



Smithco may require the return of failed parts or components in order to determine the validity of any warranty claim.



Smithco will not be obligated to replace components of other manufacturers if inspection by the original component manufacturer indicates that failure was due to normal wear and tear, expected consumption through use or improper care or service.

Other Legal Disclaimers:

The above remedy for product defects through repair or replacement by an authorized Smithco distributor or dealer is the purchaser’s sole remedy for any defect. This warranty gives you specific legal rights, and you may also have other rights which vary from state to state.

THERE ARE NO OTHER EXPRESS WARRANTIES OTHER THAN THOSE SET FORTH ABOVE. ALL IMPLIED WARRANTIES OF MERCHANTABILITY AND FITNESS FOR USE ARE LIMITED TO THE DURATION OF THE LIMITED WARRANTIES CONTAINED HEREIN.

Some states may not allow limitations on how long an implied warranty lasts, so the above limitation may not apply to you.

THE SMITHCO COMPANY IS NOT LIABLE FOR INDIRECT, INCIDENTAL OR CONSEQUENTIAL DAMAGES IN CONNECTION WITH THE USE OF THE PRODUCT, INCLUDING ANY COST OR EXPENSE OF PROVIDING A SUBSTITUTE PRODUCT OR SERVICE DURING PERIODS OF MALFUNCTION OR NON-USE.

Some states may not allow the exclusion of indirect, incidental or consequential damages, so the above exclusion may not apply to you.

Smithco neither assumes, nor authorizes any person to assume for it, any other liability in connection with the sale or use of this product.

