

Parts Manual



Sand Star Diesel
Model 45-205-C
3WD-Hydraulic Steering

SN: 5D301

Product Support:

Hwy 55 & Poplar Ave; Cameron WI 54822

1-800-891-9435 productsupport@smithco.com

CONTENTS

Introduction	Introduction..... 1-3
	Introduction 1
	Safe Practices 2
Service	Specifications 3
	Service..... 4-11
	Maintenance 4-6
	Service Chart..... 7
	End User’s Service Chart 8
	Adjustments9-11
Diagrams	Storage 11
	Diagrams 12-15
	Wiring Diagram 12-13
Parts	Hydraulic Diagram 14-15
	Parts..... 16-53
	Main Frame 16-17
	Seat Panel 18-19
	Front Fork 20-21
	Dashboard 22-23
	Foot Pedal Linkage 24-25
	Floorboard 26-27
	Right Fender/Fuel Tank 28-29
	Left Fender/Oil Tank 30-31
	18HP Kubota Engine 32-33
	Cooler & Radiator & Engine 34-35
	Pump & Pulley 36-37
	Rear Axle 38-39
	Rear Rake Lift..... 40-41
	Center Lift 42
	13-769 Valve 43
	34-103 Orbitol 44-45
	45-067 Front Wheel Motor..... 46
43-241/43-242 Rear Wheel Motors 48-49	
45-373 DDC20 Piston Pump 50-51	
Accessories	Decals..... 52
	Quick Reference..... 53
	Accessories 54-58
	45-004 Roll Bars 54-55
	45-016 Roll Bar Light Kit..... 56-57
Reference	45-390 Front/Rear Light Kit 58
	Front Attachments..... A1-15
	Center Attachments..... B16-37
Rear Attachments C38-95	
	Warranty 4

Thank you for purchasing a **Smithco** product.

Read this manual and all other manuals pertaining to the Bunker Rake carefully as they contain safety, operating, assembly and maintenance instructions. Failure to do so could result in personal injury or equipment damage.

Keep manuals in a safe place after operator and maintenance personnel have read them. Right and left sides are from the operator's seat, facing forward.

 **WARNING:**

Engine exhaust and some of its constituents are known to the State of California to cause cancer, birth defects, and other reproductive harm.

For more information visit www.P65Warning.ca.gov

WARNING

Failure to follow cautious operating practices can result in serious injury to the operator or other persons. The owner must understand these instructions, and must allow only trained persons who understand these instructions to operate this vehicle.

All **Smithco** machines have a Serial Number and Model Number. Both numbers are needed when ordering parts. Serial number tag is located on left rear ROPs mount post. Refer to engine manual for placement of engine serial number.

For product and accessory information, help finding a dealer, or to register your product please contact us at www.Smithco.com.

Information needed when ordering replacement parts:

1. Model Number of machine
2. Serial Number of machine
3. Name and Part Number of part
4. Quantity of parts

For easy access record your Serial and Model numbers here.

SMITHCO			CE
WAYNE, PENNSYLVANIA 19087 USA 610-688-4009 Fax 610-688-6069			
SERIAL NO.	kW/hp	DATE OF MFG.	
<input type="text"/>	<input type="text"/>	<input type="text"/>	
MODEL NO.	lb/kg Empty	lb/kg Full	
<input type="text"/>	<input type="text"/>	<input type="text"/>	

SAFE PRACTICES

1. It is your responsibility to read this manual and all publications associated with this machine (engine, accessories and attachments).
2. Never allow anyone to operate or service the machine or its attachments without proper training and instructions. Never allow minors to operate any equipment.
3. Learn the proper use of the machine, the location and purpose of all the controls and gauges before you operate the equipment. Working with unfamiliar equipment can lead to accidents.
4. Wear all the necessary protective clothing and personal safety devices to protect your head, eyes, ears, hands and feet. Operate the machine only in daylight or in good artificial light.
5. Inspect the area where the equipment will be used. Beware of overhead obstructions and underground obstacles. Stay alert for hidden hazards.
6. Never operate equipment that is not in perfect working order or without decals, guards, shields, or other protective devices in place.
7. Never disconnect or bypass any switch.
8. Carbon monoxide in the exhaust fumes can be fatal when inhaled, never operate a machine without proper ventilation.
9. Fuel is highly flammable, handle with care.
10. Keep engine clean. Allow the engine to cool before storing and always remove the ignition key.
11. After engine has started, machine must not move. If movement is evident, the neutral mechanism is not adjusted correctly. Shut engine off and readjust so the machine does not move when in neutral position.
13. Never use your hands to search for oil leaks. Hydraulic fluid under pressure can penetrate the skin and cause serious injury.
14. This machine demands your attention. To prevent loss of control or tipping of the vehicle:
 - A. Use extra caution in backing up the vehicle. Ensure area is clear.
 - B. Do not stop or start suddenly on any slope.
 - C. Reduce speed on slopes and in sharp turns. Use caution when changing directions on slopes.
 - D. Stay alert for holes in the terrain and other hidden hazards.
15. Before leaving operator's position for any reason:
 - A. Disengage all drives.
 - B. Lower all attachments to the ground.
 - C. Shut engine off and remove the ignition key.
16. Keep hands, feet and clothing away from moving parts. Wait for all movement to stop before you clean, adjust or service the machine.
17. Keep the area of operation clear of all bystanders.
18. Never carry passengers.
19. Stop engine before making repairs/adjustments or checking/adding oil to the crankcase.
20. Use parts and materials supplied by **Smithco** only. Do not modify any function or part.

These machines are intended for professional maintenance on golf courses, sports turf, and any other area maintained turf and related trails, paths and lots. No guaranty as to the suitability for any task is expressed or implied.

SPECIFICATIONS DIESEL SAND STAR

WEIGHTS AND DIMENSIONS

Length	68" (1.7 m)
Width	58" (1.47 m)
Height	52" (1.2 m)
Wheel Base	42" (1.07 m)
Weight	1020 lbs. (508 kg)

SOUND LEVEL (EAR PROTECTION REQUIRED)

At Ear Level	89 dB
--------------	-------

ENGINE

Make	Kubota
Model#	D-722
Type / Spec#	E3B
Horsepower	18 hp (14 kW)
Fuel	Diesel fuel No. 2 No. 2-D, S500: Low Sulfur Diesel (LSD) less than 500 ppm or 0.05 wt. % No.2-D, S15: Ultra Low Sulfur Diesel (ULSD) less than 15 ppm or 0.0015 wt. %
Cooling System	Liquid Cooled
Lubrication System	Full Pressure
Alternator	16 amp

WHEELS & TIRE

Three: 22 X 11 - 10.0 Knobby Tires 5 psi (.34 bar)
Optional: 23-10.50 x 12 Turf Tires 5 psi (.34 bar) Smithco # 48-265
Front tire fluid filled to 80 lbs. Total 45.5 pints of windshield washer fluid

SPEED

Forward Speed	0 to 11 m.p.h. (0-18 kph)
Reverse Speed	0 to 5 m.p.h. (0-8 kph)

BATTERY

BCI Group	Lawn & Garden Size 35
Cold Cranking Amps	300
Ground Terminal Polarity	Negative (-)
Maximum Length	9" (23 cm)
Maximum Width	5.38" (14 cm)
Maximum Height	9" (23 cm)

FLUID CAPACITY

Crankcase Oil	See Engine Manual
Fuel	20 quarts (18.93 liters)
Hydraulic Fluid	20 quarts (18.93 liters)
Grade of Hydraulic Fluid	SAE 10W-40 API Service SJ or higher Motor Oil

ROPS CERTIFICATION

ROPs	ISO 21299
Seat belts	OSHA 1928.51

HYDRAULIC PRESSURES

Piston Pump Displacement	.913 in ³	Charge Pump Displacement	.33 in ³ /rev
Pump Input Speed (up to)	3600 rpm	Max. Inlet Vacuum	5 in. Hg
Max. Operating Pressure	3000 peak psi	Max. Case Pressure	25 psi
Implement Setting	345 psi	Relief Valve Pressure (set at)	1230 psi
13-729 Hydraulic Valve (2 bank)	900 psi		

MAINTENANCE

⚠ CAUTION

Before servicing or making adjustments to machine, stop engine and remove key from ignition.

⚠ IMPORTANT

Use all procedures and parts prescribed by the manufacturer's. Read the engine manual.

LUBRICATION

Use No. 2 General purpose Lithium Base Grease and lubricate every 100 hours. The Diesel Sand Star has six grease fittings.

Two located on the foot pedal mount.

One on each rake lift mount.

One located on the steering cylinder.

One located on the center lift cylinder. .

REMOTE AIR CLEANER

1. Un-clip the two clips, remove the cover and pull out the element.
2. To service, clean by tapping gently on flat surface. Do not oil. Replace if very dirty or damaged.
3. Clean out the inside of the body and cover.
4. Place the element into the body and put the cover back on.

TOWING

When it is necessary to move the Sand Star without engine running, bypass valve built into hydrostatic pump must be "open" by turning it counterclockwise. The valve is located on the right side of the pump. An "open" valve allows fluid to pass through the wheels freely. When normal, driven, operation is desired, valve should be "closed" by turning it clockwise. Failure to "close" the valve with engine running means no power to wheels. The machine can be moved for a short distance with the engine off, but we **do not** recommend this as a standard procedure. When towing **do not** tow the machine faster than 2-3 MPH (3-5 km/h) because the drive system may be damaged. The tires may lock up if the machine is towed too fast. If this occurs, stop towing the machine. If the machine must be moved a considerable distance, transport it on a truck or trailer.

FUEL EMISSIONS

With the emissions control now in effect, the CF-4 and CG-4 lubricating oils have been developed for use of a low-sulfur fuel on on-road vehicle engines. When and off-road vehicle engine runs on a high-sulfur fuel, it is advisable to employ the CF, CD, or CE lubricating oils with a high total base number. If the CF-4 or CG-4 lubrication oil is used with high-sulfur fuel, change the lubricating oil more often.

Lubricating oil recommended when a low-sulfur or high-sulfur fuel is used.

Lubricating Oil Class	Fuel	
	Low-sulfur	High-sulfur
CF	O	O
CF-4	O	X
CG-4	O	X

TIRE PRESSURE

Caution must be used when inflating a low tire to recommended pressure. Over inflating can cause tires to explode. Tires should be 5 psi (0.34 bar). Improper inflation will reduce tire life considerably.

ENGINE

For Kubota Diesel engine use oil classified "For Service CC, CD or CE" API oil. Use no special additives with recommended oils. Do not mix oil with gasoline. If the CF-4 or CG-4 lubrication oil is used with high-sulfur fuel, change the lubricating oil more often.

SAE VISCOSITY GRADES

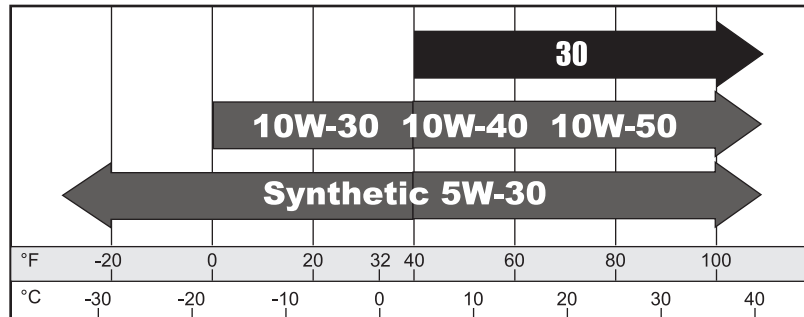

Starting Temperature Range Anticipated Before Next Oil Change

Use of multi-viscosity oils above 80° F (27° C) will result in high oil consumption and possible engine damage. Check oil level more frequently if using these types of oils.

SAE 30 oil, if used below 40° F (4° C), will result in hard starting and possible engine bore damage due to inadequate lubrication.

HYDRAULIC OIL

1. Use SAE 10W-40 API Service SJ or higher motor oil.
2. For proper warranty, change oil every 500 hours or annually, which ever is first and change filter after the first 50 hours, then every 250 hours thereafter.
3. The oil level should be 2" to 2¹/₂" from top of tank when fluid is cold. Do not overfill.
4. After changing oil and/or filter, run the machine for a few minutes. Check oil level and for leaks.
5. Always use caution when filling hydraulic oil tank or checking level to keep system free of contaminants. Check and service more frequently when operating in extremely cold, hot or dusty conditions.
6. If natural color of fluid is black or smells burnt, it is possible that an overheating problem exists.
7. If fluid becomes milky, water contamination may be a problem.
8. If either of the above conditions happen, change oil and filter immediately after fluid is cool and find cause. Take fluid level readings when system is cold.
9. In extreme temperatures you can use straight weight oil. We recommend SAE 30W API Service SJ or higher when hot (above 90°F (33°C)) and SAE 10W API Service SJ or higher when cold (below 32°F (0°C) ambient temperature. Use either motor oil or hydraulic oil, but do not mix.
10. Oil being added to the system must be the same as what is already in the tank. Mark tank fill area as to which type you put in.

MAINTENANCE

WHEEL MOUNTING PROCEDURE

1. Turn machine off and remove key.
2. Block one of the other wheels.
3. Loosen nuts slightly on wheel to be removed.
4. Jack up machine being careful not to damage underside of machine.
5. Remove nuts. Remove wheel.
5. Place new wheel on hub lining up bolt holes.
6. Torque nuts to 64-74 ft/lb (87-100 Nm) using a cross pattern. Re-torque after first 8 hours and every 200 hours thereafter.
7. Lower machine to ground and remove blocks and jack.

BATTERY

Batteries normally produce explosive gases which can cause personal injury. Do not allow flames, sparks or any ignited object to come near the battery. When charging or working near battery, always shield your eyes and always provide proper ventilation.

Battery cable should be disconnected before using "Fast Charge".

Charge battery at 15 amps for 10 minutes or 7 amps for 30 minutes. Do not exceed the recommended charging rate. If electrolyte starts boiling over, decrease charging.

Always remove grounded (-) battery clamp first and replace it last. Avoid hazards by:

1. Filling batteries in well-ventilated areas.
2. Wear eye protection and rubber gloves.
3. Avoid breathing fumes when electrolyte is added.
4. Avoid spilling or dripping electrolyte.

⚠ WARNING

Battery Electrolyte is an acidic solution and should be handled with care. If electrolyte is splashed on any part of your body, flush all contact areas immediately with liberal amounts of water. Get medical attention immediately.

JUMP STARTING

⚠ WARNING

Use of booster battery and jumper cables. Particular care should be used when connecting a booster battery. Use proper polarity in order to prevent sparks.

To jump start (negative grounded battery):

1. Shield eyes.
2. Connect ends of one cable to positive (+) terminals of each battery, first (A) then (B).
3. Connect one end of other cable to negative (-) terminal of "good" battery (C).
4. Connect other end of cable (D) to engine block on unit being started (NOT to negative (-) terminal of battery)

To prevent damage to other electrical components on unit being started, make certain that engine is at idle speed before disconnecting jumper cables.

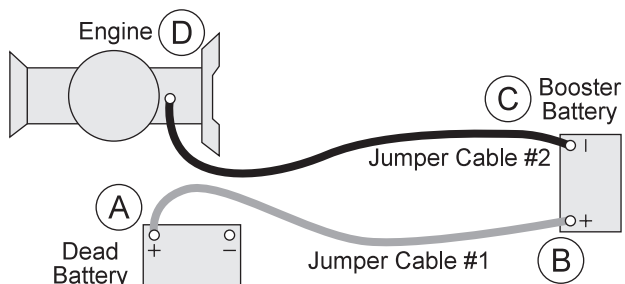

SERVICE CHART

⚠ CAUTION

Before servicing or making adjustments to the machine, stop engine, set park break, block wheels and remove key from ignition.

⚠ IMPORTANT

Follow all procedures and **ONLY** use parts prescribed by the manufacturer. Read the engine manual before maintenance.

The suggested maintenance checklist is not offered as a replacement for the manufacturer's engine manual but as a supplement. You must adhere to the guidelines established by the manufacturer for warranty coverage. In adverse conditions such as dirt, mud or extreme temperatures, maintenance should be more frequent.

Maintenance Service Interval	Maintenance Procedure
After the first 8 operating hours	Torque the wheel lug nuts. (64-74 ft/lb (87-100 Nm))
	Change the engine oil filter.
Before each use daily	Check the engine oil level.
	Clean area around muffler and controls.
	Check the hydraulic fluid level.
	Check the tire pressure.
	Check condition of hydraulic hoses and fittings.
	Check for oil or water leaks.
	Proper function of glow lamp timer.
	Color of exhaust fumes.
Inspect and clean the machine.	
After the first 50 hours	Change Hydraulic Oil Filter.
	Change Engine oil and filter.
Every 100 hours	Clean or change air filter.1
	Clean pre-cleaner.1
	Change engine oil and filter.
	Lubricate machine.
	Clean or change remote air cleaner.
	Check the battery fluid level and cable connections..
Check belt tension .	
Every 200 hours	Check radiator hoses and clamp bands.
	Check idle speed.
	Replace oil filter cartridge.
	Change hydraulic oil filter.
	Check air intake line
	Torque the wheel lug nuts. (64-74 ft/lb (87-100 Nm))
Every 500 hours or yearly	Change fuel filter.
	Change hydraulic oil and filter.
	Clean oil cooler fins.1
	Clean air cooling system.1
	Change radiator coolant.
Check safety filter in remote air cleaner.	
1 In dusty conditions or when airborne debris is present, clean more often.	



RAKE LIFT CYLINDER

Completely lower Rake Lift. Remove the clevis pin (A). Twist lift linkage (C) so clevis pin end of cylinder extension lines up with holes in attachment lift arm (B). Replace clevis and cotter pins. Tighten Jam Nut (D). Raise and lower Rake Lift to check for proper clearance.

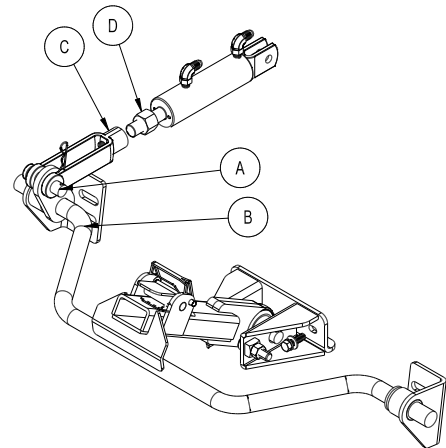

Tighten until there is sufficient tension between lift arm and quick hitch and will not move in full up position.

CAUTION

When the rear rake attachment is lowered while the machine is in forward motion, the forward speed of the machine will slow drastically. Operator should be prepared for a rapid change in speed.

PARK BRAKE

The park brake is located on the left hand side of the machine and operates both rear wheels. Pull lever back to engage and push forward to disengage.

To adjust, turn the knob on the end of the handle.

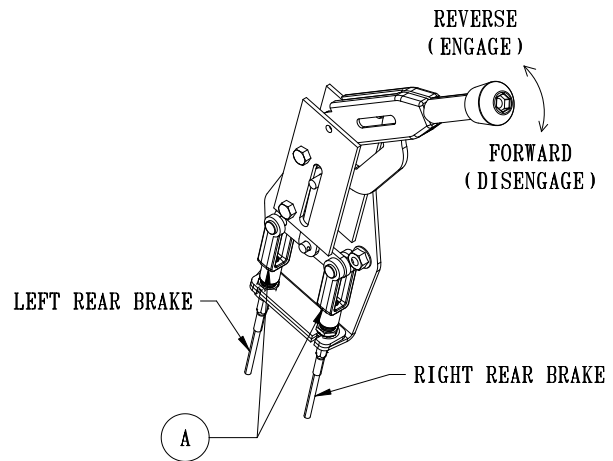

DRUM BRAKE ADJUSTMENT

The brake can be adjusted through the access hole in the backing plate. Remove the rubber plug from the backing plate. Using a drum brake adjusting tool, or a suitable flat blade screw driver, rotate the adjusting star towards the axle shaft to expand the shoes, one click at a time. Expand the shoes until slight contact is made with the drum. It is highly recommended that you adjust 1 click at a time. Rotate the drum back and forth to insure the brake is not rubbing excessively, if so back off the adjuster star. Slight rubbing is acceptable as the brake is used it will seat in. Test after each adjustment.

Brake Adjustment

Remove Cover



Move 1 click at a time.

Adjustment Gear

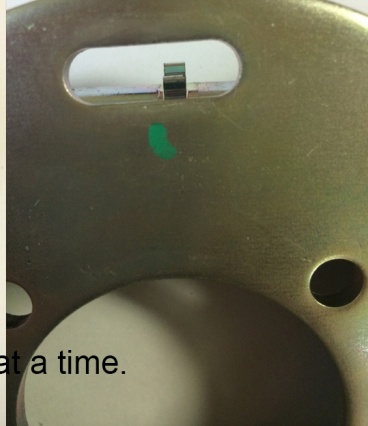

ADJUSTMENTS

WHEEL 'CREEP' ADJUSTMENT

'Creep' is when engine is running and hydrostatic transmission is in neutral, but due to inadequate alignment, wheels still move. Do the following procedures to stop this motion.

1. Lift up and support machine so all wheels are off the ground and can turn freely.
2. On the side of the pump there is a Creep Arm. Loosen bolt (B).
3. With engine running adjust the creep arm side to side in slot so centering arm centers on the control lever.
4. Tighten all fasteners and test by using foot pedal linkage to see that the "creep" is removed.
5. Turn engine off and lower machine.

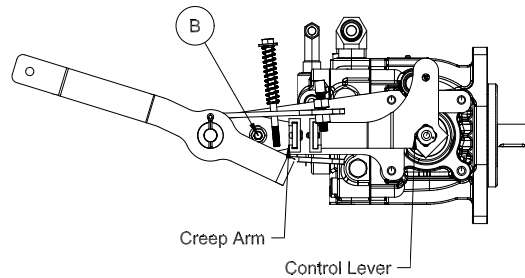

TO ADJUST FOOT PEDAL THROTTLE CABLE

1. Jack up unit so that all drive wheel are off the ground. (Use jack stands)
2. Start the engine, make certain that the hand throttle is in the idle position (1200 engine RPM).
3. Engine speed must increase as soon as the foot pedal begins to move in either direction. At the full forward position, the engine RPM must be 3000 RPM \pm 100.
4. Minor adjustment can be made by backing out (unscrewing) Retainer (Ref A) until you reach full engine RPM with the foot pedal fully depressed in the forward position. Be sure to recheck after the nuts are fully tightened.
5. Major adjustment needs to be made by loosening the screw in the wire block on the engine that is clamped onto the end of the cable and sliding it up to the cable block that is through the throttle plate. Do not let the throttle plate move to increase idle speed. Tighten the screw.
6. Test run to determine that there is no binding and that engine idle speed is 1200 RPM and that it is 3000 RPM at full forward position of the foot pedal.

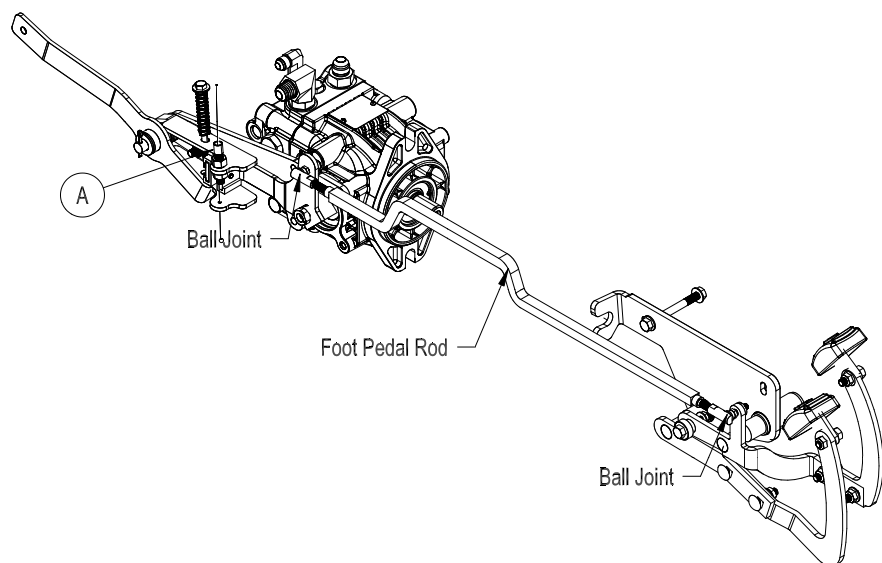

SPEED BOSS

Speed Boss allows the machine to operate at a proper speed while raking sand traps on golf courses.

This speed boss has been factory set at an average speed of 3-4 m.p.h. (5-6.5 kph). The Speed Boss will only limit the speed while the rake is lowered into the operating position. The speed setting may be adjusted by turning the Ball Joint (A) counterclockwise to make the machine operate slower or turn clockwise to go faster. Tighten jam nut. Check to make sure nothing is binding and test drive to check desired speed.

For RBS System, Spiker and Grader Box remove the speed boss arm and the speed boss rod from machine so it does not interfere with other operations.

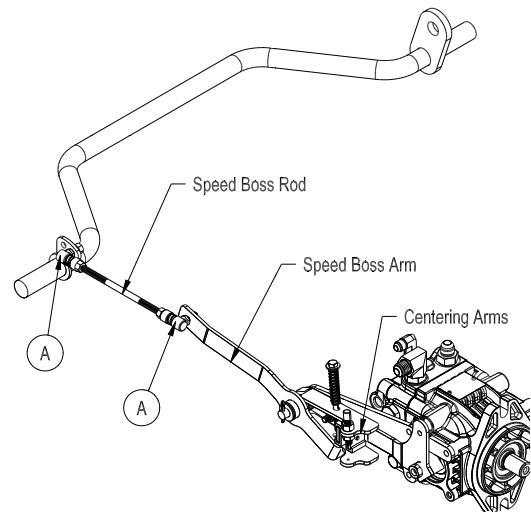

ADJUSTMENT OF BELT TENSIONER

The belt tensioner controls the tension on the belt from the engine to the pump. The proper tension of the idler should be in the second notch on the side of the tensioner. Over tightening the belt will shorten the life of the belt and the machine may not perform to the best of its ability. To adjust belt tensioner, loosen the bolt holding the tensioner (Ref A). Bring idler pulley tight to the belt and turn tensioner into belt to the second notch. Tighten bolt on tensioner.

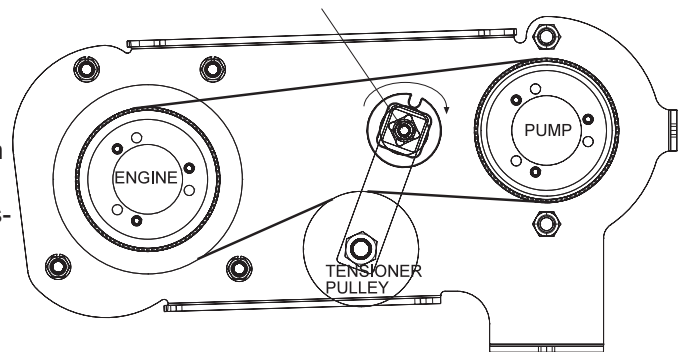

STORAGE

When storing, remove the key from the key switch to avoid unauthorized persons from operating machine.

1. Before storing clean machine thoroughly.
2. Check bolts and nuts, tighten as necessary.
3. Make all repairs that are needed and remove any debris.
4. Remove the battery, adjust the electrolyte level and recharge it. Store the battery in a dry, dark place.
5. Store in a clean and dry area, but NOT near a stove, furnace or water heater which uses a pilot light or any device that can create a spark.
6. Engines stored over 30 days need to be protected or drained of fuel to prevent gum from forming in a fuel system. Check the engine manual and follow the instructions for the storage of the engine.

WIRING DRAWING

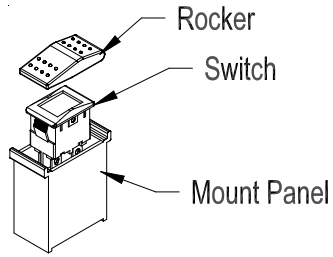

Color Code Chart

Bl	Blue
Br	Brown
Y	Yellow
Grn	Green
O	Orange
R	Red
B	Black
P	Purple
W	White

Diagrams

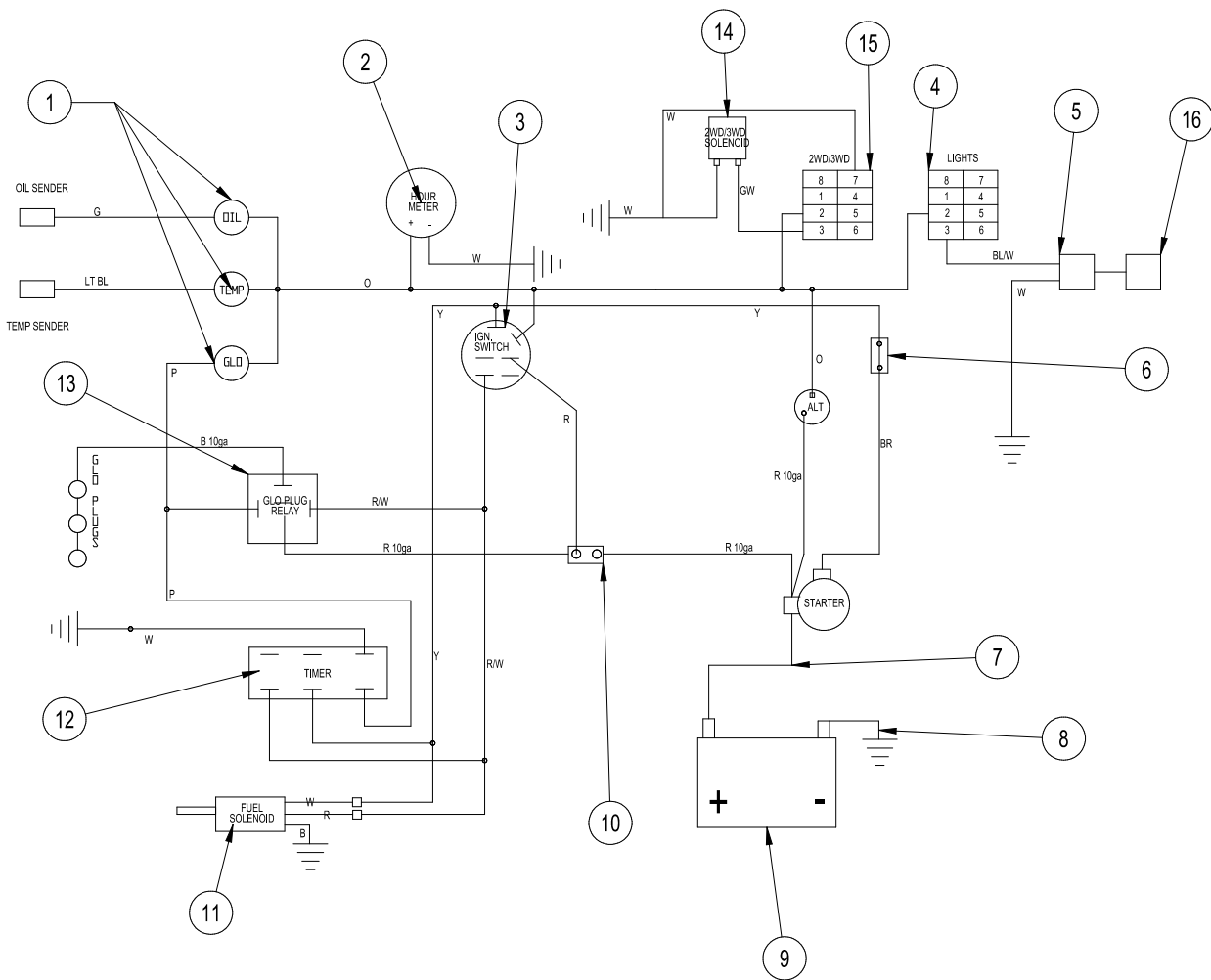

WIRING PARTS LIST

REF #	PART #	DESCRIPTION	QUANTITY
1	50-359	Warning Indicator Lights	3
2	12-804	Hour Meter	1
3	13-488	Ignition Switch	1
4	Light Switch		
	15-729	Mount Panel Middle	2
	15-727	Rocker, No Light	1
	15-782	Non-Lighted Switch	1
5**	15-783	Switch Connector	1
	15-814	2-contact Tower	1
	45-357	Cavity Plug	2
6	14-292	Seat Switch	1
7	76-326	Battery Cable Red	1
8	22-054	Ground Battery Cable Black	1
9		Battery (not included)	1
10	77-261	Circuit Breaker, 40 amp	1
	8977	Breaker Boot	1
11	17-254	Solenoid	1
12	77-223	Glow Lamp Indicator	1
13	30-042-06	Relay	1
14	42-118	Electric On/Off Valve	1
	42-118-01	Coil	1
15	2WD/3WD On/Off Switch		
	15-725	Mount Panel End	1
	15-726	Lighted Switch	1
	15-731	Rocker, Amber Light	1
16*	43-505*	Lights Wire Harness (optional)	1
	34-201*	Lights (optional)	3
**	45-426	Wire Harness	1
*	45-016	Light Kit (Requires ROPs)	

HYDRAULIC PARTS LIST

REF #	PART #	DESCRIPTION	QUANTITY
1	10-554	Steering Cylinder	1
	18-154	Rod End	1
	HNJ-58-18	Jam Nut ⁵ / ₈ -18	1
2	45-025	Hydraulic Hose, 29"	1
3	45-136	Hydraulic Hose, 24"	1
4	34-103	Orbital	1
5	45-024	Hydraulic Hose, 37.50"	1
6	45-027	Hydraulic Hose, 40"	1
7	10-554	Center Lift Cylinder	1
	18-154	Rod End	1
	HNJ-58-18	Jam Nut ⁵ / ₈ -18	1
8	45-216	Hydraulic Hose, 22.50"	1
9	45-218	Hydraulic Hose, 21"	1
10	13-769	2-Bank Valve	1
11	45-220	Hydraulic Hose, 45.5"	1
12	45-219	Hydraulic Hose, 45"	1
13	43-150	Rear Rake Cylinder	1
	42-040	Yoke	1
	HNJ-58-18	Jam Nut, ⁵ / ₈ -18	1
14	45-034	Hydraulic Hose, 70"	1
15	42-118	Electric On/Off Valve	1
16	45-221	Hydraulic Hose, 27"	1
17	45-382	Cooler	1
18	45-236	Hydraulic Hose, 24"	1
19	45-424	Hydraulic Hose, 22"	1
20	43-242	RH Rear Wheel Motor w/ Brake	1
21	45-425	Hydraulic Hose, 23"	1
22	45-211	Top Right Hydraulic Tube	1
23	45-212	Bottom Right Hydraulic Tube	1
24	43-241	LH Rear Wheel Motor	1
25	45-237	Hydraulic Hose, 12.5"	1
26	45-224	Hydraulic Hose, 19"	1
27	45-373	Piston Pump	1
28	45-235	Hydraulic Hose, 45"	1
29	42-005	Oil Tank	1
	13-747	Filler Breather	1
30	23-006	Oil Filter	1
	23-031	Replacement Filter only	1
31	8832	³ / ₄ " Suction Hose	36.5"
	18-040	Hose Clamp	2
32	45-238	Hydraulic Hose, 54"	1
33	45-067	Front Wheel Motor	1
34	45-035	Hydraulic Hose, 74"	1

Diagrams

HYDRAULIC PRESSURES

Piston Pump Displacement	.913 in ³	Charge Pump Displacement	.33 in ³ /rev
Pump Input Speed (up to)	3600 rpm	Max. Inlet Vacuum	5 in. Hg
Max. Operating Pressure	3000 peak psi	Max. Case Pressure	25 psi
Implement Setting	345 psi	Relief Valve Pressure (set at)	1230 psi
13-729 Hydraulic Valve (2 bank)	900 psi		



MAIN FRAME DRAWING

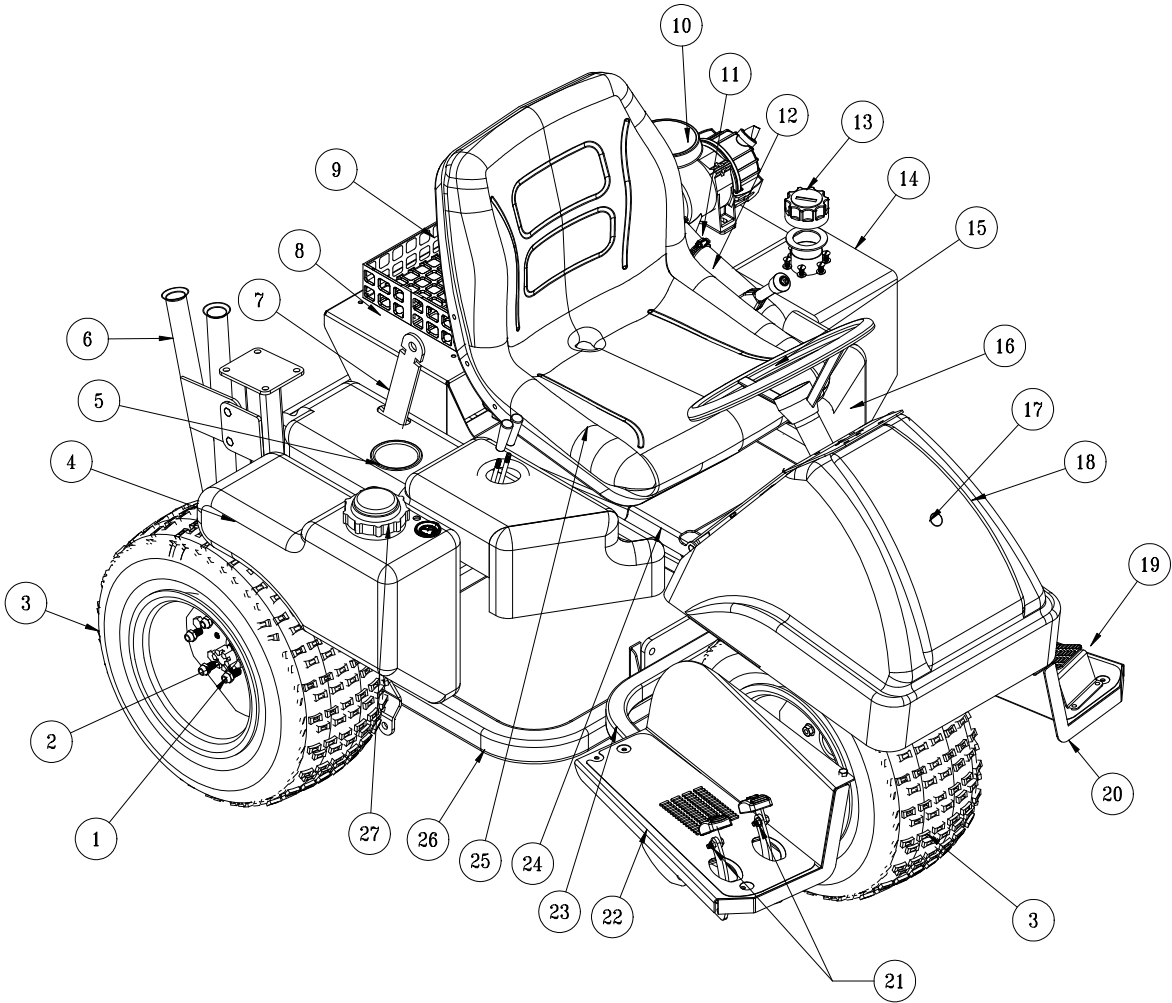

Parts

Cyclonic air cleaner 42-834

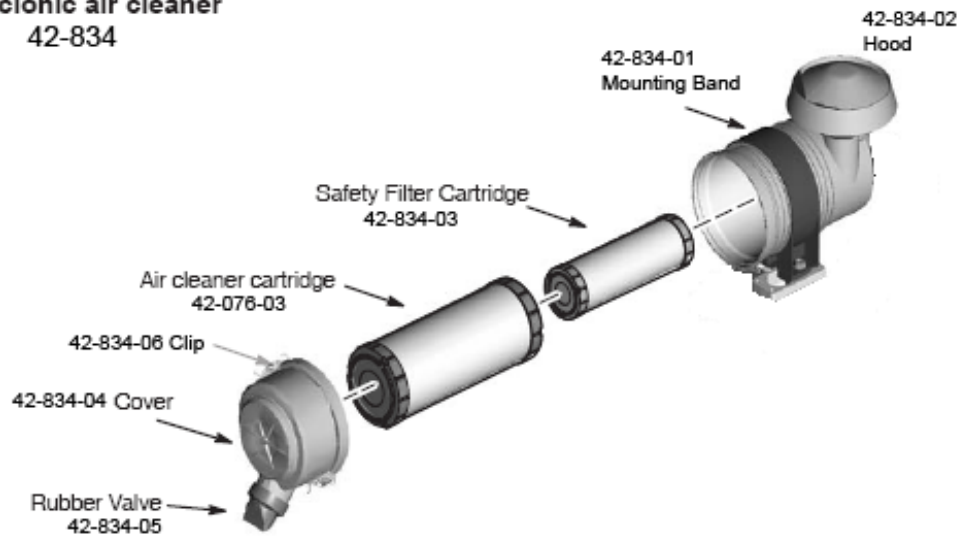

MAIN PARTS LIST

REF#	PART#	DESCRIPTION	QUANTITY
1	HNL-12-20	Lug Nuts, 1/2 - 20	10
2	14-265	Axle Nut (part of wheel motor)	3
3	45-021	Knobby Tire and Wheel	3
	45-021-01	Tire, 22 x 11 - 10	3
	45-021-02	Wheel	3
4	42-833	Fuel Tank	1
5	45-228	Right Fender	1
	8803	Black Trim	11"
	15-781	Cup Holder	1
6	45-123	Rake Holder	1
7	76-198-03	Seat Belt (optional comes with ROPs)	1
8	45-342	Radiator Cover	1
9	8-532	Crate	1
10	42-834	Air Cleaner	1
	42-834-01	Band	1
	42-834-02	Hood	1
	42-834-03	Safety Filter	1
	42-076-03	Replacement Filter	1
11	9044	Coolant Hose	3"
	18-116	Hose Clamp	2
12	45-229	Air Cleaner Tube	1
13	13-747	Filler Breather	1
	13-586-03	Neck	1
14	42-005	Oil Tank	1
15	21-498	Steering Wheel	1
	21-499	Center Cap	
16	45-227	Left Fender	1
17	18-436	Lock Hole Plug	1
18	45-026	Nose Cone	1
	8803	Black Trim	45"
19	45-047	Foot Rest Plate	1
	45-132	Foot Rest Grip	1
20	45-099	LH Floorboard	1
	45-064	LH Floor Mat	1
21	45-022	Molded Foot Pedal	2
22	45-098	RH Floorboard	1
	45-063	RH Floor Mat	1
23	45-145	Floorboard Frame	1
24	45-352	Seat Panel	1
25	14-293	Adjustable Low Back Seat	1
26	45-050	Main Frame	1
27	42-814-02	Fuel Cap	1

OPTIONAL TURF TIRES

48-265	Tire & Wheel	3
43-123-01	Turf Tires, 5 psi (.34 bar)	3
16-857-02	Wheel, 23-10.50 x 12	3

SEAT PANEL DRAWING

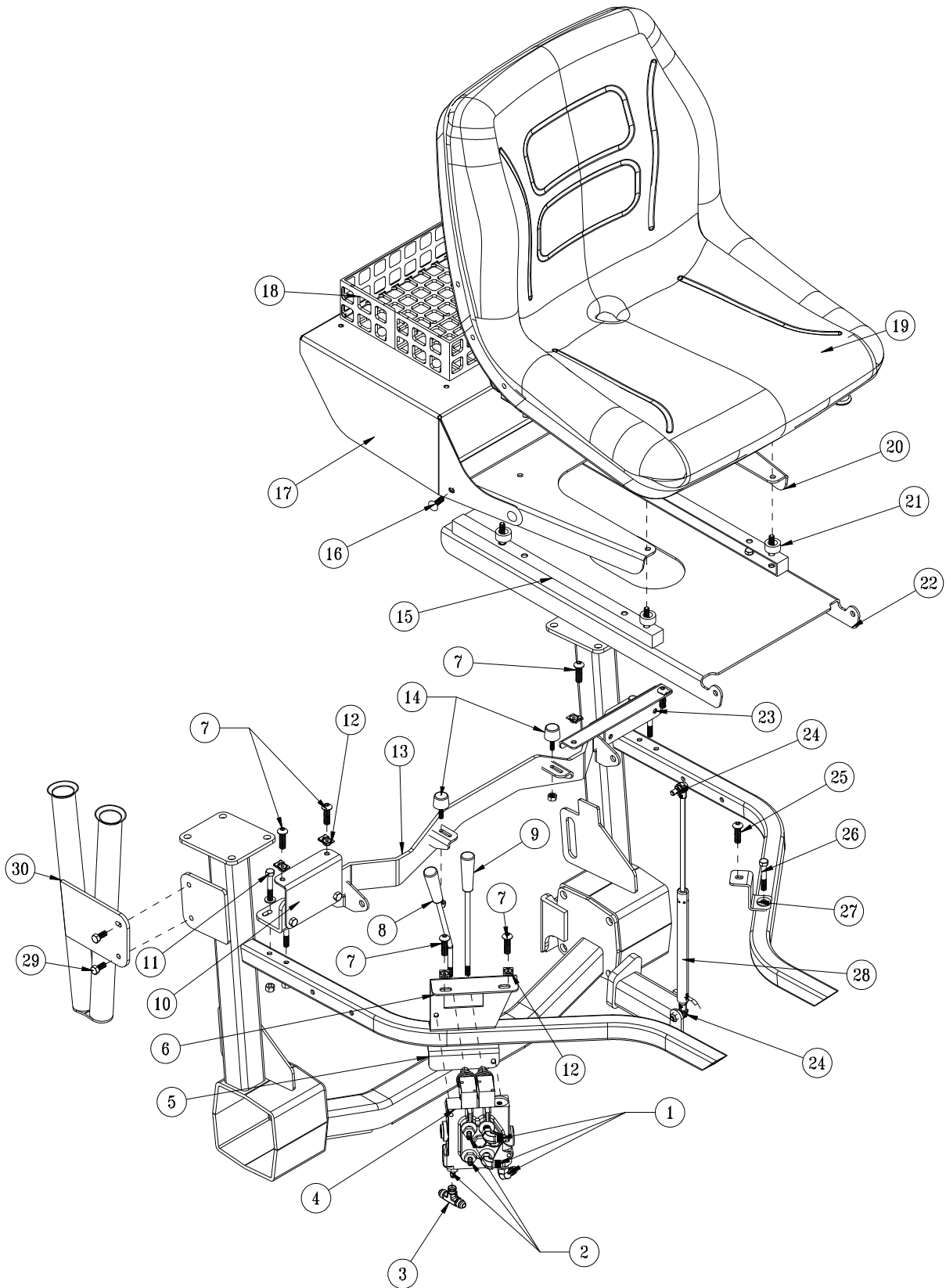

Parts

SEAT PANEL PARTS LIST

REF#	PART#	DESCRIPTION	QUANTITY
1	18-185	90° O-ring Elbow	3
2	18-241	Straight Adapter	3
3	32-020	Tee	1
4	13-769	2-Bank Valve	1
5	45-325	Lower Valve Bracket	1
6	45-324	Upper Valve Bracket	1
7	HSTP-516-18-100	Phillips Machine Screw, $\frac{5}{16}$ - 18 - 1	6
8	45-358	Bent Handle, 15°	1
9	78-417	Straight Handle	1
10	45-086	RH Rear Fender Bracket	1
11	HB-14-20-175	Hex Bolt, $\frac{1}{4}$ - 20 x $1\frac{3}{4}$	4
	HW-14	Flat Washer, $\frac{1}{4}$	4
	HNFL-14-20	Flange Whiz-loc Nut, $\frac{1}{4}$ -20	4
12	78-274	Cage Nut, J-type	6
13	45-351	Seat Belt Bar	1
14	15-013	Rubber Bumper	2
	HNTL-516-18	Nylon Lock Nut, $\frac{5}{16}$ - 18	2
15	14-800	Seat Rail - set (comes with seat)	1
	HB-516-18-100	Hex Bolt, $\frac{5}{16}$ - 18 - 1	4
	HNFL-516-18	Flange Whiz-loc Nut, $\frac{5}{16}$ - 18	4
16	HSTP-516-18-075	Phillips Machine Screw, $\frac{5}{16}$ - 18 - $\frac{3}{4}$	4
	HNFL-516-18	Flange Whiz-loc Nut, $\frac{5}{16}$ - 18	4
17	45-342	Radiator Cover	1
18	8-532	Basket	1
19	14-293	Adjustable Low Back Seat	1
20	45-343	Radiator Cover Mount	1
21	HSP-1260-340-250	Seat Spacer	4
22	45-352	Seat Panel	1
23	45-113	LH Rear Fender Mount	1
24	26-034	Ball Stud	2
	HNFL-516-18	Flange Whiz-loc Nut, $\frac{5}{16}$ - 18	2
25	HSTP-516-18-100	Phillips Machine Screw, $\frac{5}{16}$ - 18 - 1	1
26	HB-14-20-175	Hex Bolt, $\frac{1}{4}$ - 20 x $1\frac{3}{4}$	1
	HW-14	Flat Washer, $\frac{1}{4}$	1
	HNFL-14-20	Flange Whiz-loc Nut, $\frac{1}{4}$ -20	1
27	45-105	LH Front Fender Mount	1
28	45-356	Gas Spring	1
29	HBFL-516-18-075	Flange Hex Bolt $\frac{5}{16}$ - 18 x $\frac{3}{4}$	2
	HNFL-516-18	Flange Whiz-loc Nut, $\frac{5}{16}$ - 18	2
30	45-123	Rake Holder	1

FRONT FORK DRAWING

Parts

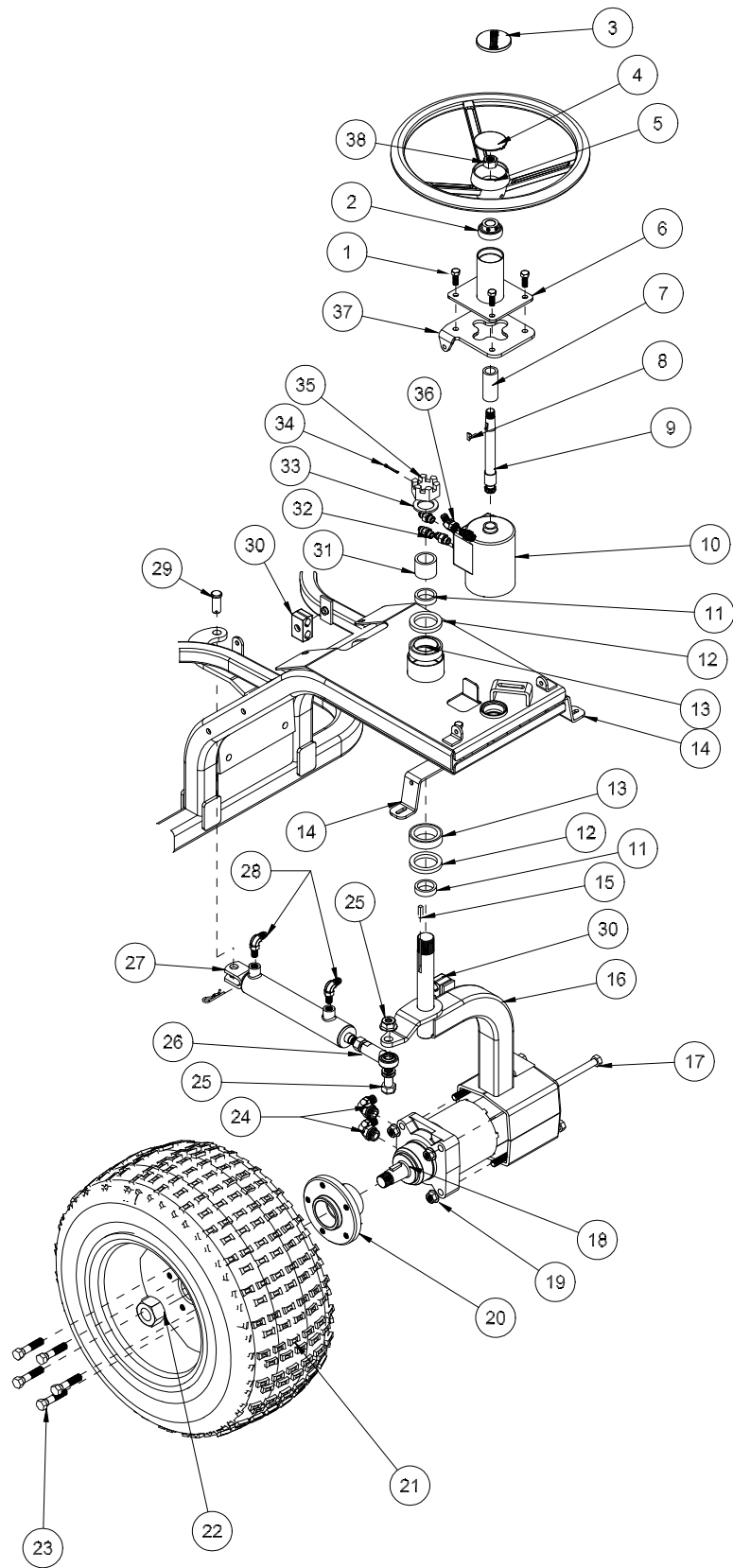

FRONT FORK PARTS LIST

REF#	PART#	DESCRIPTION	QUANTITY
1	HB-38-16-100	Hex Bolt, $\frac{3}{8}$ - 16 x 1	4
	HW-38	Washer, $\frac{3}{8}$	4
	HWL-38	Lock Washer, $\frac{3}{8}$	4
2	45-155	Bearing	1
3	27-077	Decal, Smithco Round	1
4	21-499	Center Cap	1
5	21-498	Steering Wheel	1
6	45-157	Steering Post	1
7	76-649	Shaft Spacer	1
8	HWK-316-063	Woodruff Key, $\frac{3}{16}$ x $\frac{5}{8}$	1
9	45-440	Steering Shaft	1
10	34-103	Orbital	1
11	20-141	Spacer	2
12	20-142	Oil Seal	2
13	20-143	Bearing	2
14	45-093	Front Support	2
15	HKSQ-14-100	Square Key, $\frac{1}{4}$ x $\frac{1}{4}$ x 1	1
16	45-115	Front Fork	1
17	HB-12-13-750	Hex Bolt, $\frac{1}{2}$ - 13 x $7\frac{1}{2}$	4
18	45-067	Front Wheel Motor	1
19	HNFL-12-13	Flange Whiz-loc Nut, $\frac{1}{2}$ - 13	4
20	13-033	Hub	1
21	45-021	Knobby Tire and Wheel	1
	45-021-01	Tire, 22 x 11 x 10	1
	45-021-02	Wheel	1
22	14-265	Nut (part of wheel motor)	1
23	60-268	Lug Hex Bolt	5
24	18-350	$\frac{3}{8}$ Seal Lok Elbow	2
25	HB-58-11-250	Hex Bolt, $\frac{5}{8}$ - 11 x $2\frac{1}{2}$	1
	HMB-58-14	Machine Bushing, $\frac{5}{8}$ x 14GA	3
	HNTL-58-11	Nylon Lock Nut, $\frac{5}{8}$ - 11	1
26	18-154	Rod End	1
	HG-14-28-180	Grease Fitting, $\frac{1}{4}$ - 28 x 180°	1
	HNJ-58-18	Jam Nut, $\frac{5}{8}$ - 18	1
27	10-554	Hydraulic Cylinder	1
	14-529	Seal Kit	1
	18-168	$\frac{3}{8}$ Straight Thread Elbow	2
29	HCP-58-150	Clevis Pin, $\frac{5}{8}$ - $1\frac{1}{2}$	1
	HP-18-100	Cotter Pin, $\frac{1}{8}$ x 1	1
30	13-652	Hose Clamp	1
	HB-516-18-150	Hex Bolt, $\frac{5}{16}$ - 18 x $1\frac{1}{2}$	2
	HNTL-516-18	Lock Nut, $\frac{5}{16}$ - 18	2
31	43-027	Shaft Spacer	1
32	18-169	Adapter, $\frac{3}{8}$ SAE	4
33	HMB-114-10	Machine Bushing, $1\frac{1}{4}$ x 10GA	1
34	HP-18-200	Cotter Pin, $\frac{1}{8}$ x 2	1
35	HNAR-114-12	Castle Nut, $1\frac{1}{4}$ - 12	1
36	18-188	45° O-ring Adapter	1
37	45-423	Adapter Plate	1
38	HNJ-58-18	Jam Nut, $\frac{5}{8}$ - 18	1

DASHBOARD DRAWING

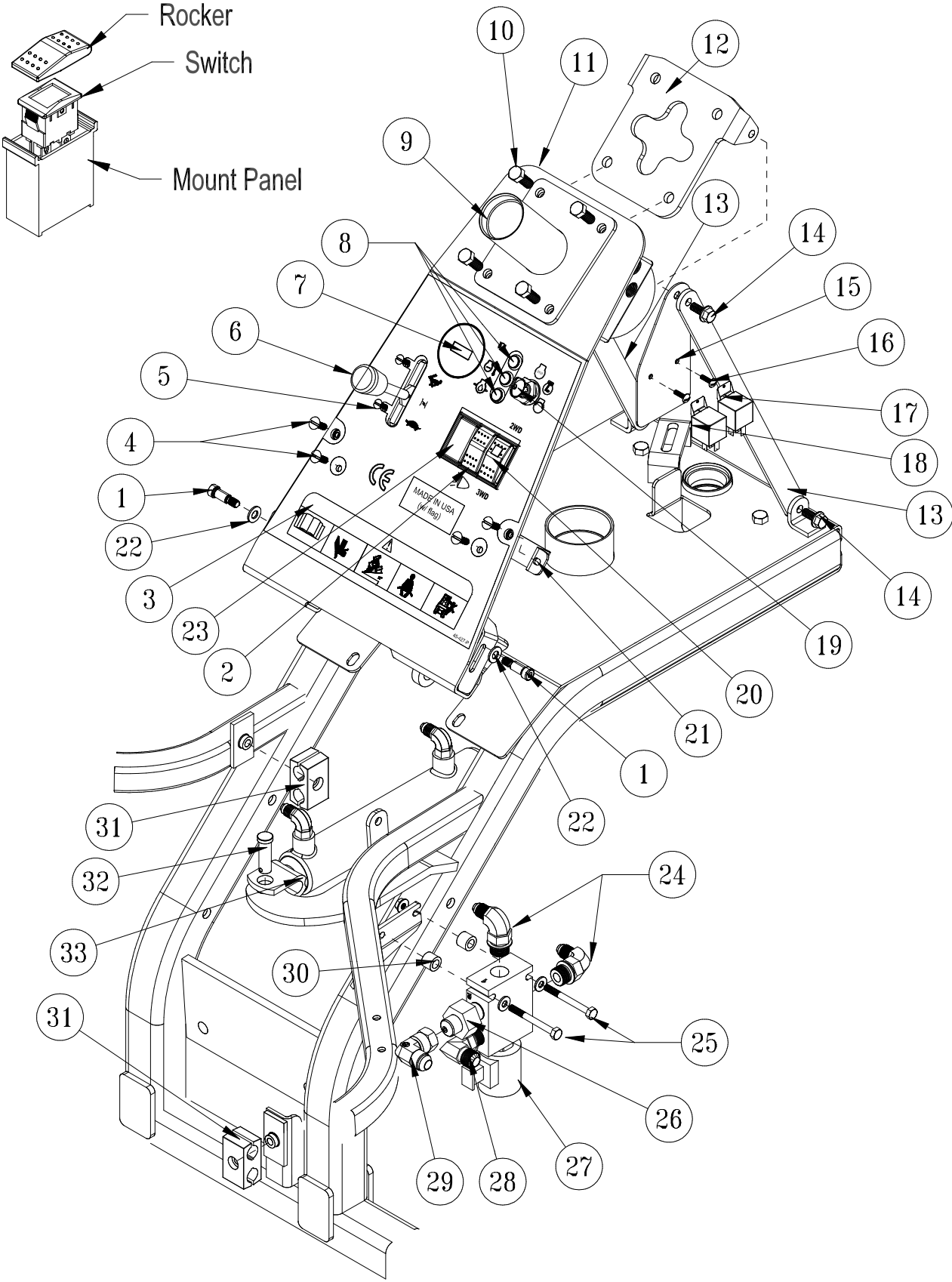

Parts

DASHBOARD PARTS LIST

REF#	PART#	DESCRIPTION	QUANTITY
1	HBSH-38-38	Shoulder Hex Bolt $\frac{3}{8}$ UNC x $\frac{3}{8}$	2
	HNSQ-516-18	Square Nut $\frac{5}{16}$ -18	2
2	15-729	Mount Panel Middle	1
	15-727	Rocker , No light	1
	15-782	Non lighted Switch	1
3	45-427	Decal, Dash Panel	1
4	HSTP-14-20-075	Phillips Machine Screw $\frac{1}{4}$ - 20 x $\frac{3}{4}$	4
	HNFL-14-20	Flange Whiz-loc Nut, $\frac{1}{4}$ - 20	4
5	HSM-10-32-063	Machine Screw, #10 - 32 x $\frac{5}{8}$	2
	HNFL-10-32	Flange Whiz-loc Nut, #10 -32	2
6	45-118	Throttle Cable	1
7	12-804	Hour Meter	1
8	50-359	Warning Indicator Light	3
9	45-157	Steering Post	1
10	HB-38-16-100	Hex Bolt, $\frac{3}{8}$ - 16 x 1	4
	HW-38	Flat Washer, $\frac{3}{8}$	4
	HWL-38	Lock Washer, $\frac{3}{8}$	4
11	45-353	Dash Board	1
12	45-423	Adapter Plate	1
13	45-124	Dash Brace	2
14	HBFL-516-18-075	Flange Hex Bolt, $\frac{5}{16}$ - 18 x $\frac{3}{4}$	4
	HNFL-516-18	Flange Whiz-loc Nut, $\frac{5}{16}$ -18	4
15	45-344	Relay Mount	1
16	HSDPS-14-075	Drill Screw, $\frac{1}{4}$ X $\frac{3}{4}$	2
	HW-14	Flat Washer, $\frac{1}{4}$	2
17	30-042-06	Relay	1
18	77-223	Lamp Timer, DC12V	1
19	13-488	Ignition Switch assembly	1
	76-310	Key Set	1
20	15-725	Mount Panel End	1
	15-731	Rocker, Amber Light	1
	15-726	Lighted Switch	1
21	45-049	Wire Retainer	1
22	HW-516	Flat Washer, $\frac{5}{16}$	2
23	15-725	Mount Panel End	1
	15-730	Mount Panel Plug	1
24	18-185	Elbow	2
25	HB-14-20-250	Hex Bolt, 1/4 - 20 x 2 1/2	2
	HW-14	Flat Washer, 1/4	2
	HNFL-14-20	Flange Whiz-loc Nut, 1/4 - 20	2
26	18-227	Straight Thread Connector	1
27	42-118	Electric On/Off Valve	1
	42-118-01	Coil	1
28	18-174	$\frac{1}{2}$ " Straight Thread Elbow	1
29	18-229	$\frac{1}{2}$ " Tube Fitting	1
30	45-154	Spacer	2
31	13-652	Hose Clamp	2
	HB-516-18-150	Hex Bolt, $\frac{5}{16}$ - 18 x 1 1/2	4
	HNFL-516-18	Lock Nut, $\frac{5}{16}$ -18	4
32	HCP-58-150	Clevis Pin, $\frac{5}{8}$ x 1 1/2	1
	HHP-18	Bridge Pin, $\frac{1}{8}$	1
33	10-554	Steering Cylinder	1
NS	45-426	Wire Harness	1

FOOT PEDAL LINKAGE DRAWING

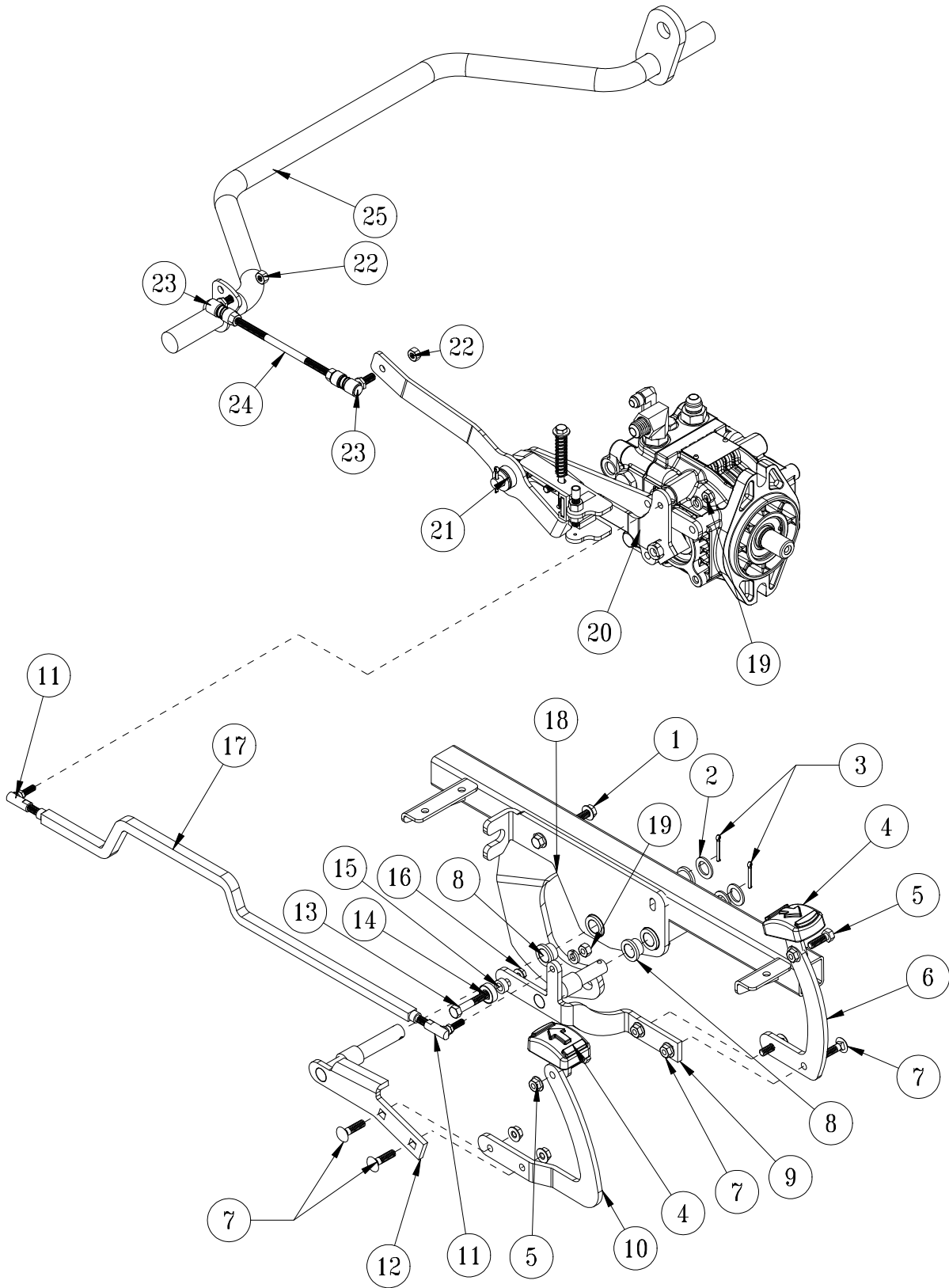

Parts

FOOT PEDAL LINKAGE PARTS LIST

REF#	PART#	DESCRIPTION	QUANTITY
1	HB-516-18-300	Hex Bolt, $\frac{5}{16}$ - 18 x 3	2
	HNFL-516-18	Flange Whiz-loc Nut, $\frac{5}{16}$ - 18	2
2	HMB-58-14	Machine Bushing, $\frac{5}{8}$ x 10GA	3
3	HP-18-100	Cotter Pin, $\frac{1}{8}$ x 1	2
4	45-022	Molded Foot Pedal	2
5	HBFL-516-18-075	Flange Whiz Hex Bolt, $\frac{5}{16}$ - 18 x $\frac{3}{4}$	2
	HNFL-516-18	Flange Whiz-loc Nut, $\frac{5}{16}$ - 18	2
6	45-133	Forward Pedal Arm	1
7	HBCL-516-18-075	Carriage Hex bolt, $\frac{5}{16}$ -18 - $\frac{3}{4}$	4
	HNFL-516-18	Flange Whiz-loc Nut, $\frac{5}{16}$ -18	4
8	76-128	Flange Bushing (part of pedal mount)	4
9	45-083	Forward Pedal Brace	1
10	45-134	Reverse Pedal Arm	1
11	21-462	Ball Joint, $\frac{5}{16}$ NF	2
12	45-084	Reverse Pedal Brace	1
13	HB-516-18-125	Stop Hex Bolt, $\frac{5}{16}$ -18 x $1\frac{1}{4}$	1
14	8-601	Micro Ball Bearing	1
15	8-622	Spacer	1
16	HNFL-516-18	Flange Whiz-loc Nut, $\frac{5}{16}$ - 18	1
17	45-240	Control Link	
18	45-147	Pedal Mount	1
	HG-14-28-180	Grease Fitting, $\frac{1}{4}$ - 28 x 180°	2
19	HWL-516	Lock Washer, $\frac{5}{16}$	2
	HN-516-24	Nut, $\frac{5}{16}$ NF	2
20		Swash Arm	1
	HSM-6-32-125	Machine Screw #6-32 x $1\frac{1}{4}$	1
	HNTL-6-32	Nylon Lock Nut, #6-32	1
21	45-346	Speed Boss Arm	1
22	HN-516-24	Nut, $\frac{5}{16}$ - 24	4
	HWL-516	Lock Washer, $\frac{5}{16}$	4
23	18-387	Quick Disconnect Ball Joints	2
24	43-147	Speed Boss Rod	1
25	45-114	Lift Bar	1

FLOORBOARD DRAWING

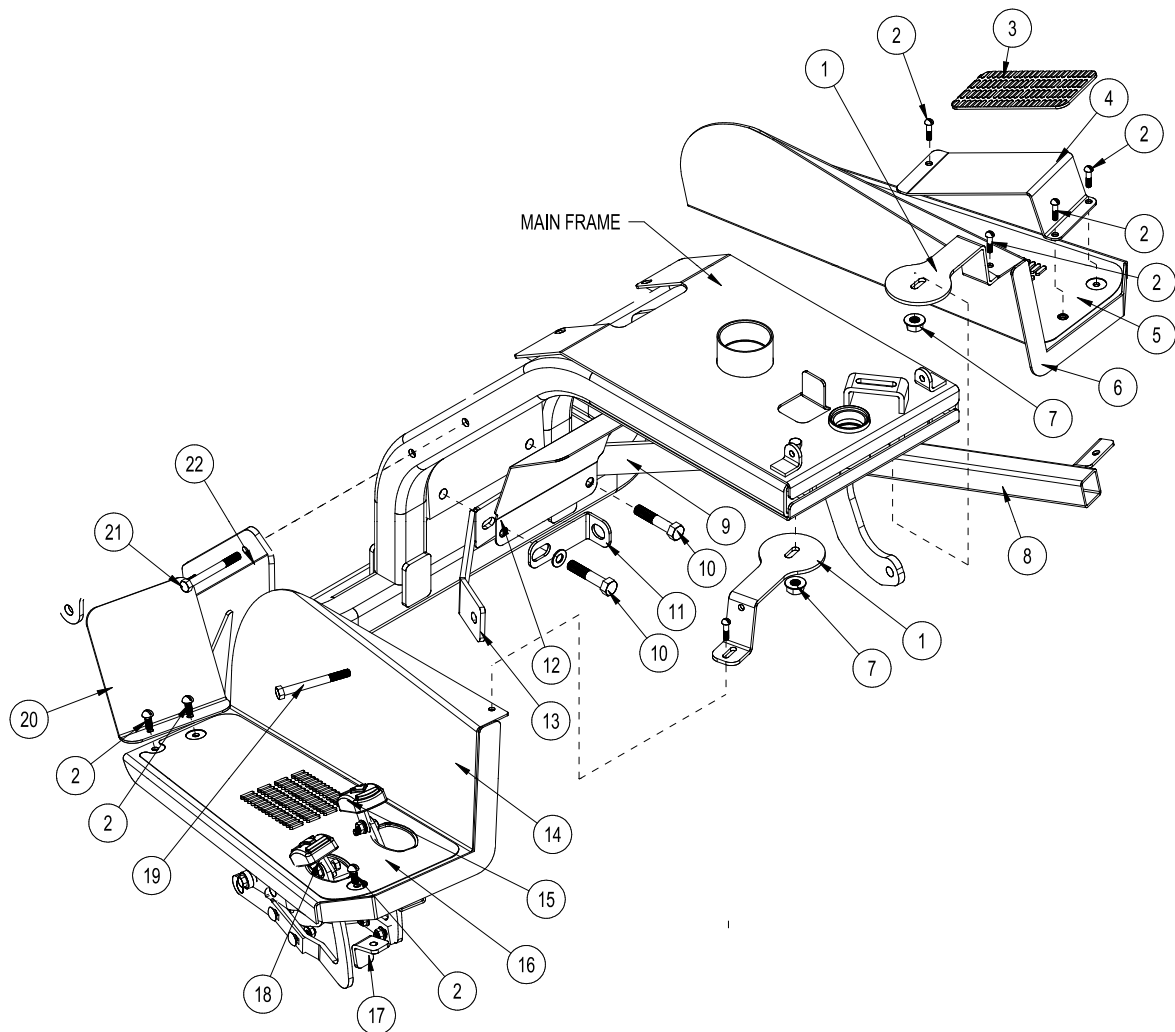

Parts

FLOORBOARD PARTS LIST

REF#	PART#	DESCRIPTION	QUANTITY
1	45-093	Front Support	2
2	HSTP-14-20-075	Truss Head Pan Screw, 1/4 -20 x 3/4	10
	HNFL-14-20	Flange Whiz-loc Nut, 1/4-20	10
3	45-132	Foot Rest Grip	1
4	45-047	Foot Rest Plate	1
5	45-064	LH Floor Mat	1
6	45-099	LH Floorboard	1
7	HNFL-38-16	Flange Whiz-loc Nut, 3/8 - 16	2
8	45-432	LH Floorboard Frame	1
9	45-433	LH Floorboard Frame Brace	1
10	HB-12-13-150	Hex Bolt, 1/2 - 13 x 1 1/2	2
	HW-12	Flat Washer, 1/2	1
	HNFL-12-13	Flange Whiz-loc Nut, 1/2- 13	2
11	45-153	Center Ram Holder	1
12	45-146	Dirt Guard	1
13	45-431	RH Floorboard Frame Brace	1
14	45-098	RH Floorboard	1
15	45-133	Forward Pedal Arm	1
	45-022	Molded Foot Pedal	1
16	45-063	RH Floor Mat	1
17	45-329	Pedal Stop	1
18	45-134	Reverse Pedal Arm	1
	45-022	Molded Foot Pedal	1
19	HB-516-18-175	Hex Bolt, 5/16 - 18 x 1 3/4	1
20	45-340	Linkage Guard	1
21	HB-38-16-225	Hex Bolt, 3/8 - 16 x 2 1/4	6
	HW-38	Flat Washer, 3/8	6
	HNTL-38-16	Nylon Lock Nut, 3/8 - 16	6
22	45-430	RH Floorboard Frame	1

RIGHT FENDER DRAWING

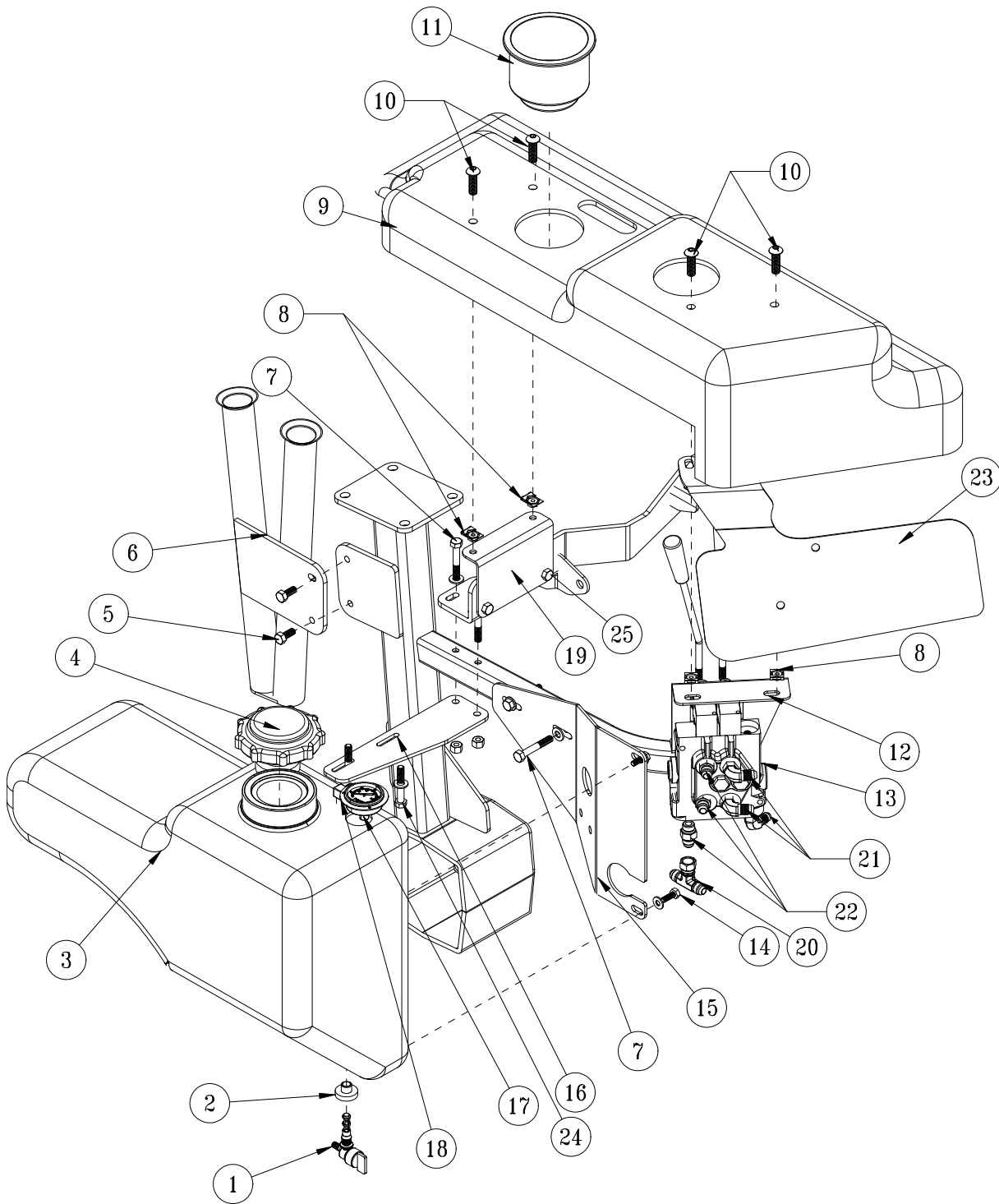

Parts

RIGHT FENDER PARTS LIST

REF#	PART#	DESCRIPTION	QUANTITY
1*	26-055	Shut-Off Valve	1
2*	26-054	Bushing Insert	1
3	42-833	Fuel Tank (includes all * items)	1
	42-814-05	Vent Check Valve	1
4*	42-814-02	Cap	1
	42-814-01	Tether	1
5	HBFL-516-18-075	Flange Hex Bolt, $\frac{5}{16}$ - 18 x $\frac{3}{4}$	2
	HNFL-516-18	Flange Whiz-loc Nut, $\frac{5}{16}$ - 18	2
6	45-123	Rake Holder	1
7	HB-14-20-175	Hex Bolt, $\frac{1}{4}$ 20 x $1\frac{3}{4}$	4
	HW-14	Flat Washer, $\frac{1}{4}$	4
	HNFL-14-20	Flange Whiz-loc Nut, $\frac{1}{4}$ -20	4
8	78-274	Cage Nut	4
9	45-228	Right Fender	1
10	HSTP-516-18-100	Phillips Machine Screw , $\frac{5}{16}$ - 18 - 1	4
11	15-781	Drink Cup Holder	1
12	45-324	Upper Valve Bracket	1
13	13-769	2-Bank Valve	1
	HB-14-20-200	Hex Bolt, $\frac{1}{4}$ 20 x 2	2
	HW-14	Flat Washer, $\frac{1}{4}$	2
	HNFL-14-20	Flange Whiz-loc Nut, $\frac{1}{4}$ -20	2
14	HB-14-20-075	Hex Bolt, $\frac{1}{4}$ - 20 x $\frac{3}{4}$	2
	HW-14	Flat Washer, $\frac{1}{4}$	2
	HWL-14	Lock Washer, $\frac{1}{4}$	2
15	45-053	RH Tank Plate	1
16	45-178	Tank Mount	1
	HB-14-20-100	Hex Bolt, $\frac{1}{4}$ 20 x 1	2
	HW-14	Flat Washer, $\frac{1}{4}$	2
	HWL-14	Lock Washer, $\frac{1}{4}$	2
17*	42-814-03	Fuel Level Gauge	1
18*	42-814-04	Top Draw	1
19	45-086	RH Rear Fender Bracket	1
	HBFL-516-18-075	Flange Whiz-loc Bolt, $\frac{5}{16}$ - 18 x $\frac{3}{4}$	2
	HNFL-516-18	Flange Whiz-loc Nut, $\frac{5}{16}$ - 18	2
20	32-020	Swivel Tee	1
21	18-185	Elbow	3
22	18-241	Adapter	3
23	45-437	Fender/Valve Brace	1
24	HB-14-20-100	Hex Bolt, $\frac{1}{4}$ 20 x 1	2
	HW-14	Flat Washer, $\frac{1}{4}$	2
	HWL-14	Lock Washer, $\frac{1}{4}$	2
25	HBFL-516-18-075	Flange Whiz-loc Bolt, $\frac{5}{16}$ -18- $\frac{3}{4}$	2
	HNFL-516-18	Flange Whiz-loc Nut, $\frac{5}{16}$ -18	2
NS	42-814-06	Rollover Valve Grommet	
	42-814-07	Top Draw Grommet	
	42-814-08	Gauge Grommet	

LEFT FENDER DRAWING

PARTS

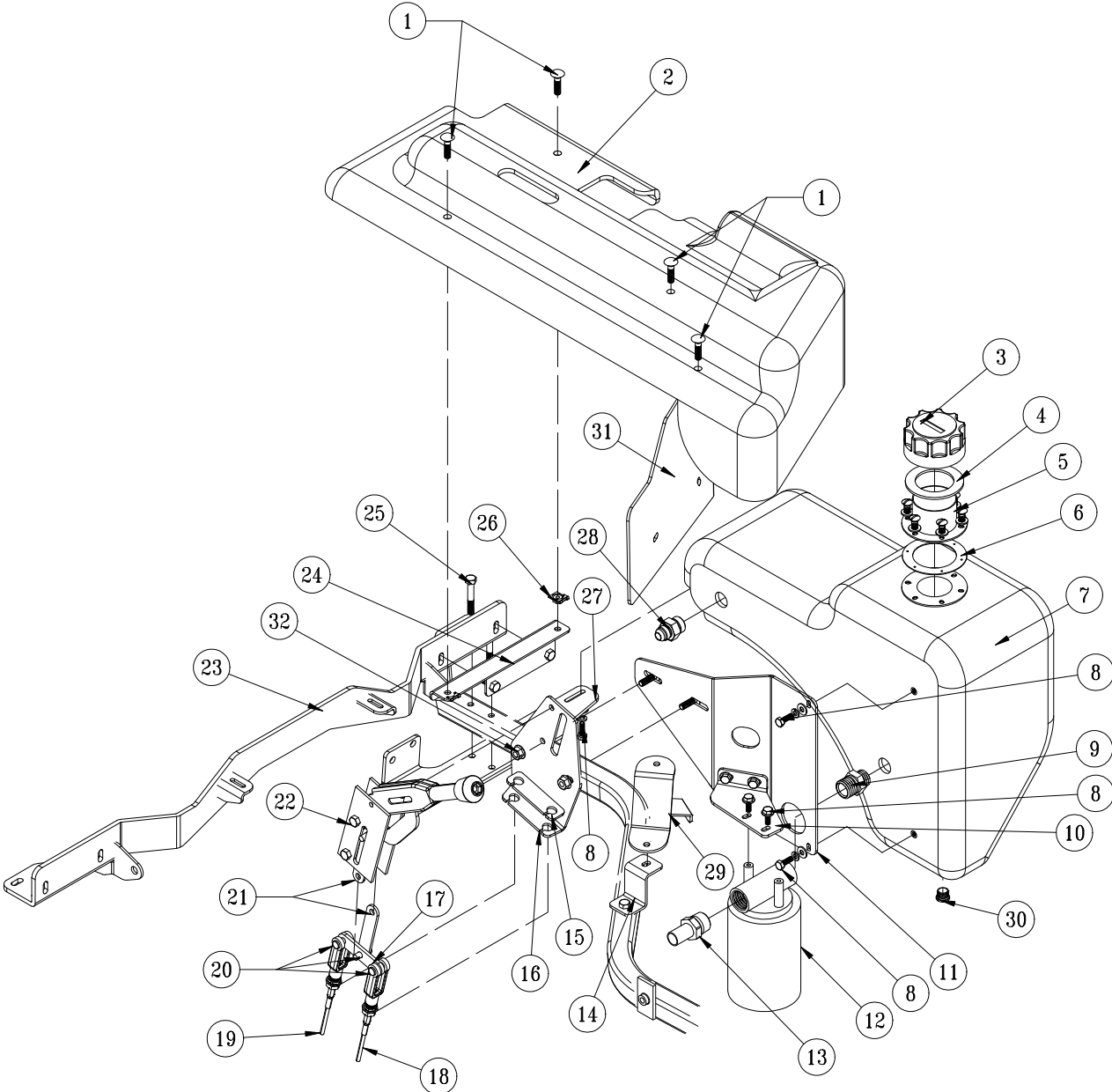

LEFT FENDER PARTS LIST

REF#	PART#	DESCRIPTION	QUANTITY
1	HSTP-516-18-100	Phillips Machine Screw , $\frac{5}{16}$ - 18 - 1	4
2	45-227	Left Fender	1
3	13-747	Filler Breather	1
4	13-586-01	Cap Gasket	1
5	13-586-03	Neck	1
	HSM-8-32-050	Machine Screw, #8 - 32 x $\frac{1}{2}$	6
	HWS-8	Star Washer, #8	6
6	13-586-02	Bottom Gasket	1
7	42-005	Oil Tank	1
8	HB-14-20-075	Hex Bolt $\frac{1}{4}$ - 20 x $\frac{3}{4}$	5
	HW-14	Flat Washer, $\frac{1}{4}$	5
	HWL-14	Lock Washer, $\frac{1}{4}$	5
9	18-459	O-ring Fitting	1
10	45-056	Oil Filter Brace	1
	HB-14-20-075	Hex Bolt, $\frac{1}{4}$ - 20 x $\frac{3}{4}$	2
	HW-14	Flat Washer, $\frac{1}{4}$	2
	HNFL-14-20	Flange Whiz-loc Nut, $\frac{1}{4}$ - 20	2
11	45-054	LH Tank Plate	1
12	23-006	Oil Filter	1
	23-031	Replacement Filter Element	1
13	18-476	Hose Barb	1
14	45-408	LH Front Fender Mount	1
	HB-14-20-175	Hex Bolt, $\frac{1}{4}$ - 20 x $1\frac{3}{4}$	1
	HNFL-14-20	Flange Whiz-loc Nut, $\frac{1}{4}$ - 20	1
15	45-070	Cable Mount Spacer	1
16	45-057	Park Brake Mount	1
17	45-075	Equalizer Link	1
18	43-240	Brake Cable (to Right brake)	1
19	45-107	Brake Cable (to Left Brake)	1
20	HCP-516-100	Clevis Pin, $\frac{5}{16}$ x 1	3
	HP-18-075	Cotter Pin, $\frac{1}{8}$ x $\frac{3}{4}$	3
21	45-074	Park Brake Link	2
22	60-106	Park Brake Lever	1
23	45-351	Seat Belt Bar	1
24	45-113	LH Rear Fender Mount	1
25	HB-14-20-175	Hex Bolt, $\frac{1}{4}$ - 20 x $1\frac{3}{4}$	2
	HW-14	Flat Washer, $\frac{1}{4}$	2
	HNFL-14-20	Flange Whiz-loc Nut, $\frac{1}{4}$ - 20	2
26	78-274	Cage Nuts	2
27	45-330	Tank / Reservoir Mount	1
28	18-343	Adapter	1
29	45-438	LH Front Fender Brace	1
30	23-126	#6 Plug	1
31	45-439	LH Fender Support	1
32	HB-516-18-200	Hex Bolt, $\frac{5}{16}$ - 18 x 2	2
	HW-516	Flat Washer, $\frac{5}{16}$	2
	HNFL-516-18	Flange Whiz-loc Nut, $\frac{5}{16}$ -18	2

ENGINE DRAWING

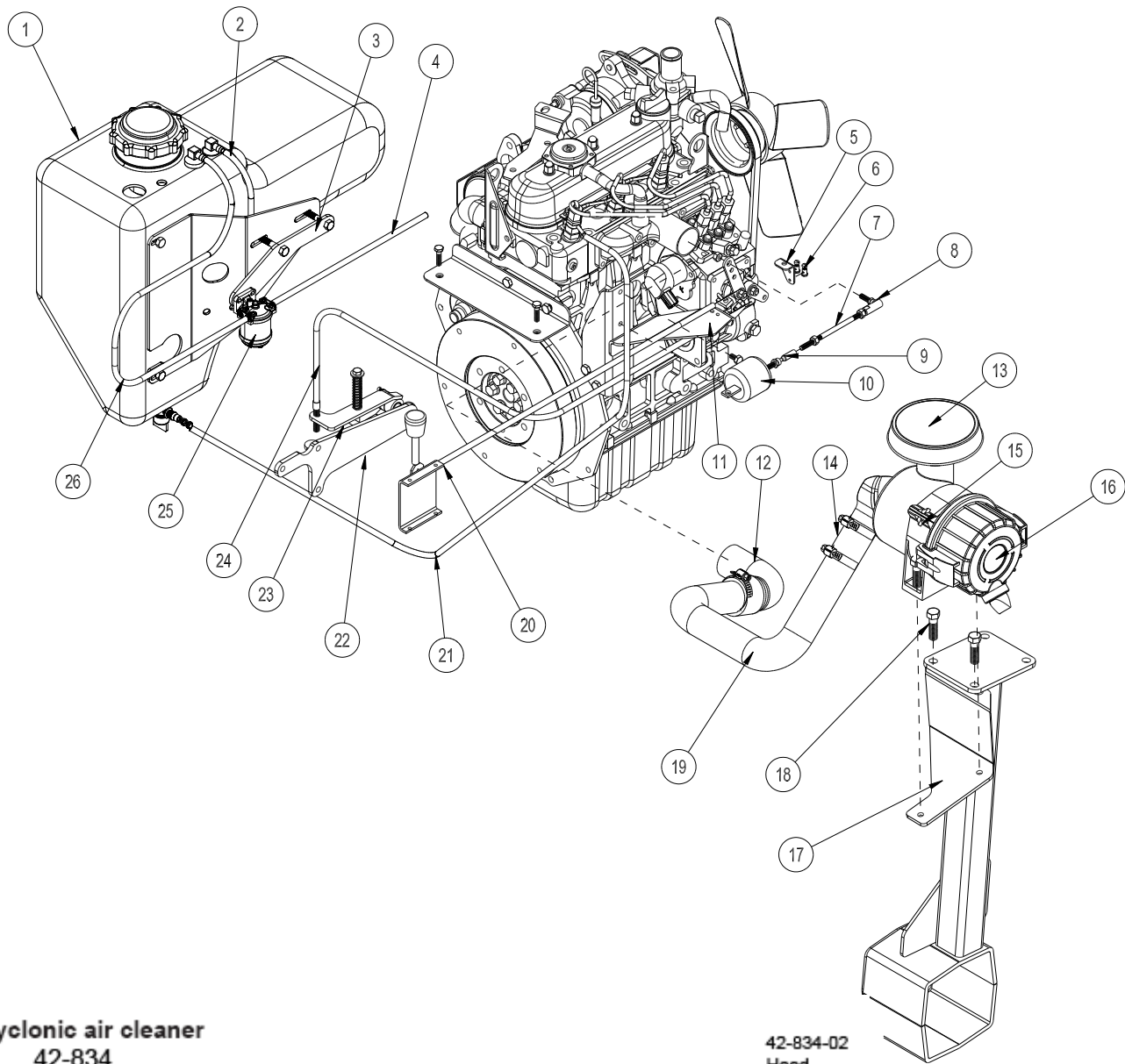

Parts

Cyclonic air cleaner
42-834

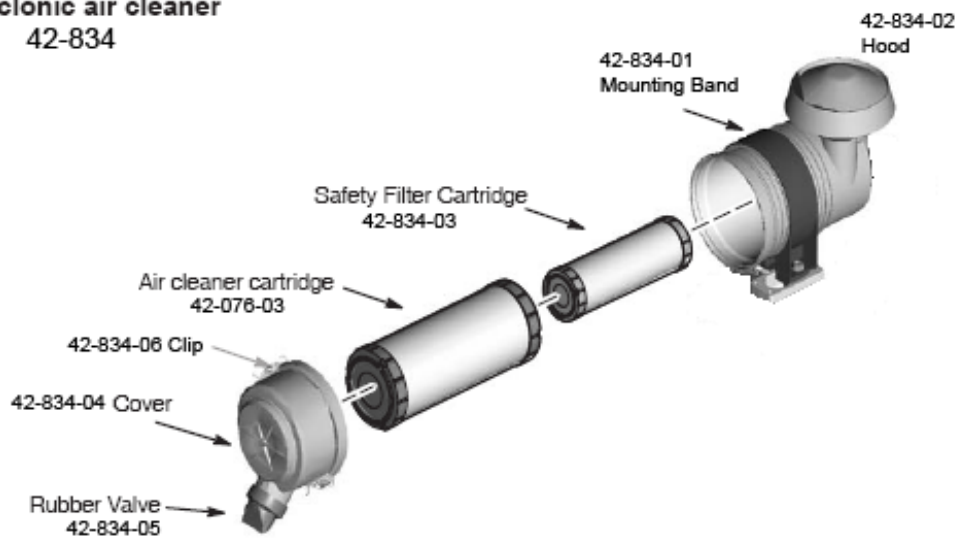

ENGINE PARTS LIST

REF#	PART#	DESCRIPTION	QUANTITY
1	42-833	Fuel Tank	1
2	8800	1/4" Fuel Hose	12"
	18-186	Hose Clamp	1
3	45-338	Fuel Filter mount	1
4	8940	5/16" Fuel Hose	46"
	18-186	Hose Clamp	2
5	45-328	Throttle Adapter	1
6	21-161	Wire Block	2
7	43-228	Solenoid Rod	1
	HN-14-28	Hex Nut, 1/4 - 28	2
8	18-115	Ball Joint	1
9	43-229	Ball Joint, 1/4 in-line	1
10		Fuel Solenoid (comes with engine)	1
11	45-347	Throttle Cable Mount	1
12		Air Inlet Elbow (comes with engine)	1
	18-116	Hose Clamp	2
13	42-834-02	Hood	1
14	9044	Coolant Hose	3"
	18-123	Hose Clamp	2
15	42-834-01	Band	1
	HB-516-18-075	Hex Bolt, 5/16 - 18 x 3/4	2
	HNFL-516-18	Flange Whiz-loc Nut, 5/16-18	2
16	42-834	Air Cleaner	1
	42-834-03	Safety Filter	1
	42-076-03	Replacement Filter	1
17	45-332	Air Cleaner Mount	1
18	HB-716-14-150	Hex Bolt, 7/16 - 14 x 1 1/2	2
	HW-716	Flat Washer, 7/16	2
	HNTL-716-14	Nylon Lock Nut, 7/16 - 14	2
19	45-229	Air Cleaner Tube	1
20	45-118	Throttle Cable	1
21	9025	3/16" Fuel Hose	31"
	18-186	Hose Clamp	2
22	45-239	Hydraulic Control Mount	1
23	45-367	Bottom Centering Arm	1
	45-368	Top Centering Arm	1
24	17-151	Cable	1
	17-152	Conduit	1
	17-155	Retainer	1
25		Fuel Filter (comes with engine)	1
26	8940	5/16" Fuel Hose	20"
	18-186	Hose Clamp	2

COOLER , RADIATOR & ENGINE DRAWING

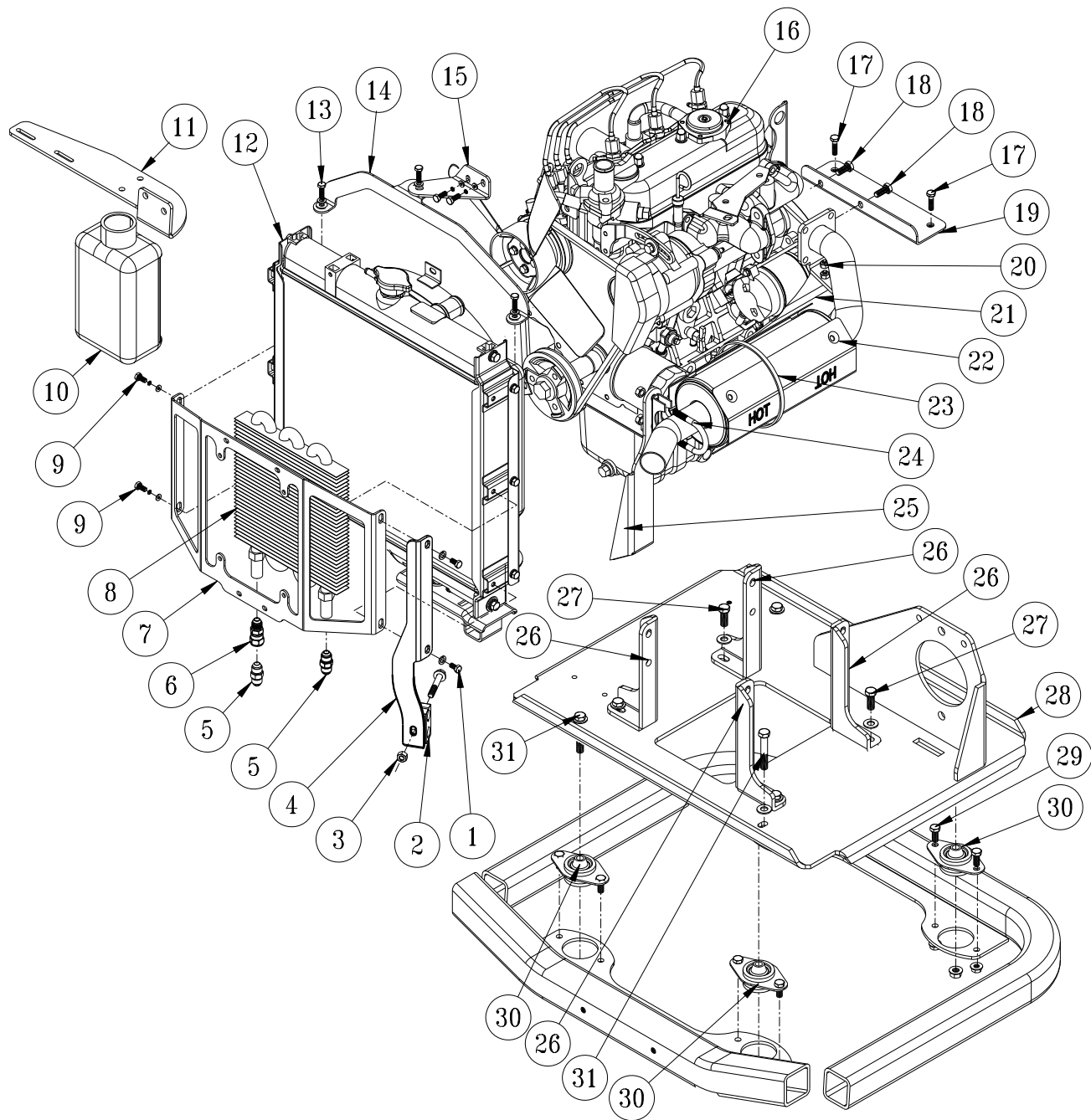

Parts

COOLER, RADIATOR & ENGINE PARTS LIST

REF #	PART #	DESCRIPTION	QUANTITY
1	HBM-6-1.0-20	Metric Hex Bolt, M6 x 20	2
	HWLM-6	Metric Lock Washer, M6	2
2	13-652-02	Hose Clamp Set	1
	13-652-03	Cover Plate	1
3	HB-516-18-200	Hex Bolt, $\frac{5}{16}$ - 18 x 2	1
	HW-38	Flat Washer, $\frac{3}{8}$	1
	HNTL-516-18	Nylon Lock Nut, $\frac{5}{16}$ - 18	1
4	45-422	Stabilizer Bracket	1
5	18-410	Connector	2
6	18-512	Hose Extender	1
7	45-323	Oil Cooler Mount	1
8	45-382	Oil Cooler	1
9	HBM-6-1.0-12	Metric Hex Bolt, #6 x 12	2
	HW-14	Flat Washer, 1/4	2
	HWLM-6	Metric Lock Washer, M6	2
10		Overflow Tank	1
11	45-330	Tank/Reservoir Mount	1
12		Radiator (comes with engine)	1
13	HBM-6-1-20	Metric Hex Bolt, #6 x 50	3
	HWLM-6	Metric Lock Washer, M6	3
	HW-14	Flat Washer, 1/4	3
14	45-331	Radiator Brace	1
15	45-341	Radiator Brace Bracket	1
	HBM-6-1-16	Metric Hex Bolt, #6 x 16	2
	HWLM-6	Metric Lock Washer, M6	2
	HW-14	Flat Washer, 1/4	2
16	45-660	Diesel Kubota Engine	1
17	HB-14-20-075	Hex Bolt, $\frac{1}{4}$ - 20 x $\frac{3}{4}$	2
18	HSSHSM-8-1.25-20	Metric Machine Screw, M8 -1.25 x 20	2
	HWLM-8	Metric Lock Washer, M8	2
19	45-345	Belt Guard Mount	1
20	HB-14-20-075	Hex Bolt, $\frac{1}{4}$ - 20 x $\frac{3}{4}$	2
	HNFL-14-20	Flange Lock Nut, $\frac{1}{4}$ - 20	2
21	45-387	Muffler Brace	1
22	45-199	Muffler	1
23	18-147	Hose Clamp	1
35	45-230	Clamping U-Hex Bolt	1
25	45-339	Muffler Brace	1
26	45-336	Engine Mount Leg	4
27	HB-38-16-100	Hex Bolt, $\frac{3}{8}$ - 16 x 1	4
	HNTL-38-16	Nylon Lock Nut, $\frac{3}{8}$ - 16	4
28	45-349	Engine Plate	1
29	HB-516-18-100	Hex Bolt, $\frac{5}{16}$ - 18 x 1	8
	HNFL-516-18	Flange Whiz-loc Nut, $\frac{5}{16}$ - 18	8
30	20-618	Rubber Insulator	4
31	HB-38-16-225	Hex Bolt, $\frac{3}{8}$ - 16 x $2\frac{1}{4}$	4
	HW-38	Washer, $\frac{3}{8}$	4
	HNTL-38-16	Nylon Lock Nut, $\frac{3}{8}$ - 16	4

PUMP AND PULLEYS DRAWING

Parts

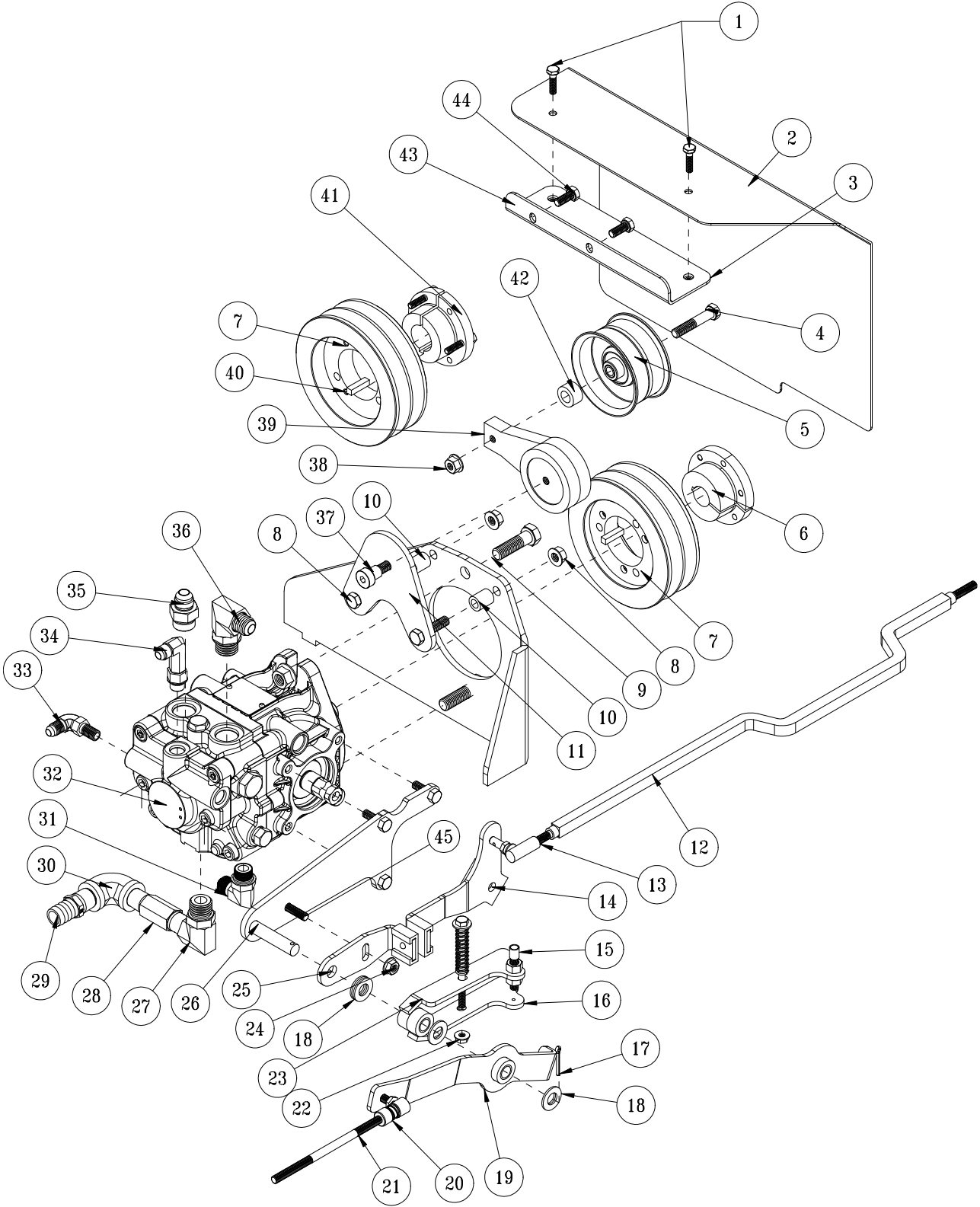

PUMP AND PULLEYS PARTS LIST

REF#	PART#	DESCRIPTION	QUANTITY
1	HB-14-20-075	Hex Bolt, 1/4 - 20 x 3/4	2
2	45-333	Belt Guard	1
3	45-345	Belt Guard Mount	1
4	HB-38-16-275	Hex Bolt, 3/8 -16 x 2 3/4	1
	HW-38	Flat Washer, 3/8	1
5	42-358	Idler Pulley	1
6	45-376	Hub, 7/8"	1
	HNSQ-14-100	Square Key, 1/4 x 1	1
	HB-14-20-125	Hex Bolt 1/4 - 20 x 1 1/4	3
	HW-14	Lock Washer, 1/4	3
7	42-331	Pulley	2
9	HB-12-13-175	Socket Screw, 1/2 - 13 x 1 3/4	2
	HNTL-12-13	Nylon Lock Nut, 1/2 - 13	2
8	HB-38-16-150	Hex Bolt, 3/8 -16 x 1 1/2	2
	HNTL-38-16	Nylon Lock Nut, 3/8 -16	2
10	10-134	Spacer	2
11	45-337	Tensioner Mount	1
12	45-240	Control Link	1
13	21-462	Ball Joint. 5/16 NF	1
14		Control Lever	1
15	17-151	Cable	1
	17-152	Conduit	1
	17-155	Retainer	1
16	45-367	Bottom Centering Arm	1
17	HP-18-100	Cotter Pin, 1/8 x 1	1
18	HMB-12-14	Machine Bushing, 1/2 x 14GA	4
19	45-346	Speed Boss Arm	1
20	18-387	Quick Disconnect Ball Joint	1
21	43-147	Speed Boss Rod	1
22	10-477	Compression Spring	1
	HNTL-14-20	Nylon Lock Nut, 1/4 - 20	1
	HB-14-20-400	Hex Bolt, 1/4 - 20 x 4	1
	HW-14	Washer, 1/4	3
23	45-368	Top Centering Arm	1
24	HNFL-516-18	Flange Whiz-loc Nut, 5/16 -18	1
25	45-327	Creep Arm	1
26	45-239	Control Mount	1
27	23-127	Elbow	1
28	18-485	3" Nipple	1
29	18-133	Hose Barb	1
30	18-484	Elbow	1
31	18-174	90° O-ring Elbow	1
32	45-373	Piston Pump	1
33	18-168	90° O-ring Elbow	1
34	18-506	Elbow	1
35	18-343	Adapter	1
36	23-189	Adjustable Elbow	1
37	HB-38-16-200	Hex Bolt, 3/8 -16 x 2	1
38	HNTL-38-16	Nylon Lock Nut, 3/8 -16	1
39	42-327	Belt Tensioner	1
40	HNSQ-14-100	Square Key, 1/4 x 1	1
41	45-197	Hub	1
	HB-14-20-125	Hex Bolt, 1/4 - 20 x 1 1/4	3
	HW-14	Lock Washer, 1/4	3
42	16-990	Spacer	1
43	45-345	Belt Guard Mount	1
44	HSSHSM-8-1.25-20	Metric Machine Screw, M8 -1.25 x 20	2
	HWLM-8	Metric Flat Washer, #8	2
45	HBCL-516-18-100	Carriage Bolt, 5/16 - 18 x 1	1
NS	45-241	Belt	2

REAR AXLE DRAWING

PARTS

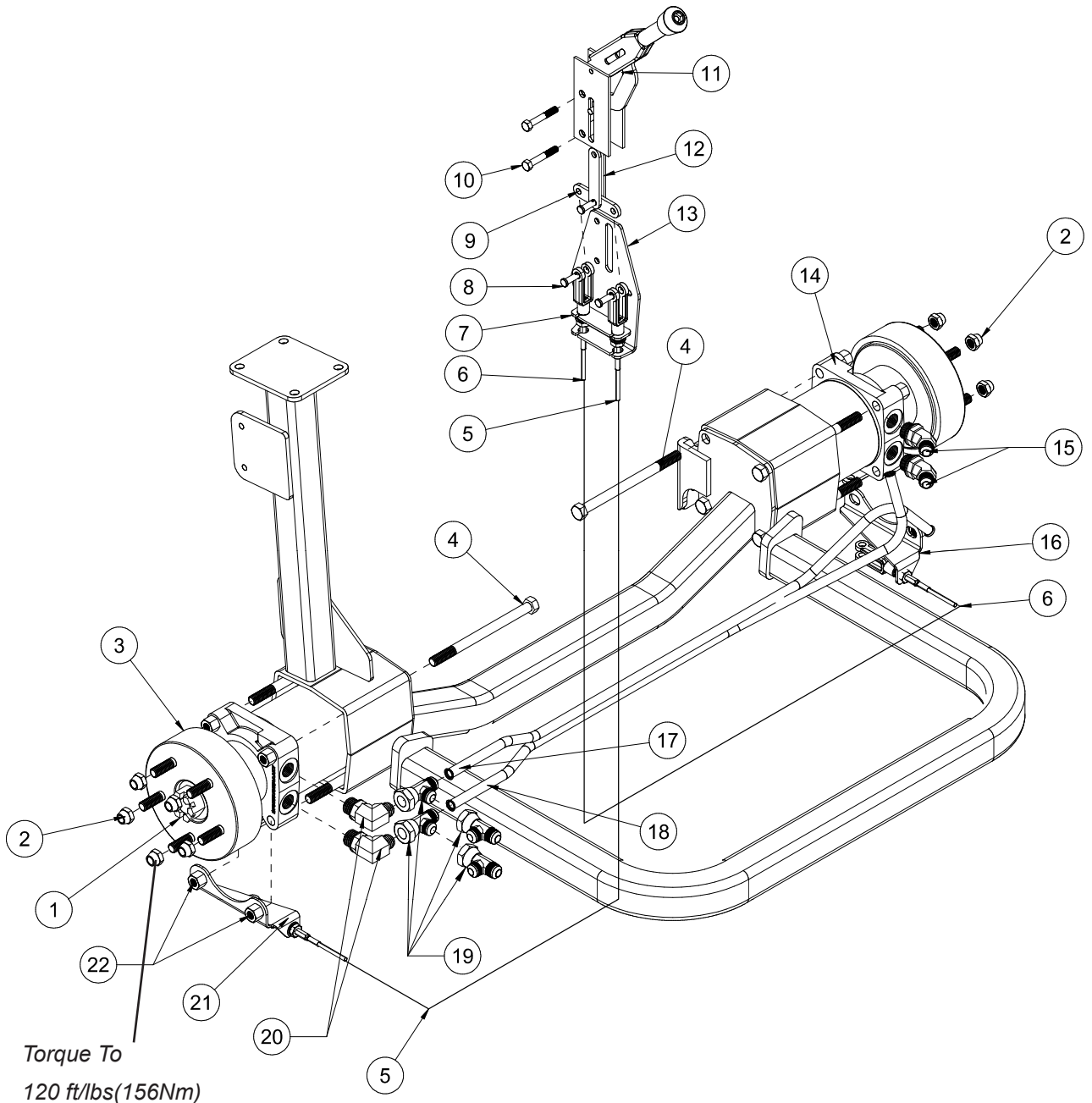

REAR AXLE PARTS LIST

REF#	PART#	DESCRIPTION	QUANTITY
1	14-265	Nut, 1-8 (part of wheel motor)	2
2	HNL-12-20	Lug Nut, 1/2 - 20	10
3	43-242	RH Brake Assembly w/ Wheel Motor	1
	45-065-01	Stud	5
4	HB-12-13-700	Hex Bolt, 1/2 - 13 x 7	8
5	43-240	RH Brake Cable	1
6	45-107	LH Brake Cable	1
7	45-070	Cable Mount Spacer	1
8	HCP-516-100	Clevis Pin, 5/16 x 1	3
	HP-18-100	Cotter Pin, 1/8 x 1	3
9	45-075	Equalizer	1
10	HB-516-18-175	Hex Bolt, 5/16 - 18 x 1 3/4	2
	HNFL-516-18	Flange Whiz-loc Nut, 5/16 - 18	2
11	60-106	Park Brake Lever	1
12	45-074	Park Brake Link	2
13	45-057	Park Brake Mount	1
14	43-241	LH Brake Assembly w/ Wheel Motor	1
	45-065-01	Stud	5
15	18-383	45° Elbow	2
16	45-080	LH Brake Cable Mount	1
17	45-211	Top Right Hydraulic Tube	1
18	45-212	Bottom Right Hydraulic Tube	1
19	18-337	Run Tee	4
20	23-189	Fitting	2
21	45-079	RH Brake Cable Mount	1
22	HNFL-12-13	Flange Whiz-loc Nut, 1/2 - 13	8

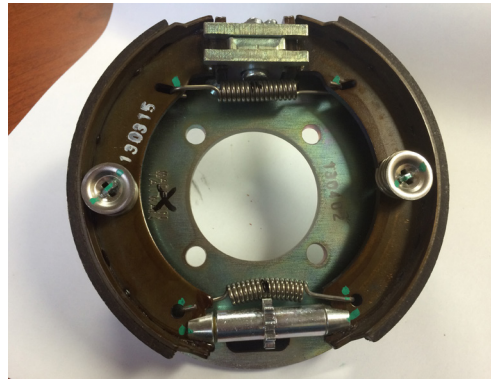

43-241-01 Brake Assembly

REAR RAKE LIFT DRAWING

PARTS

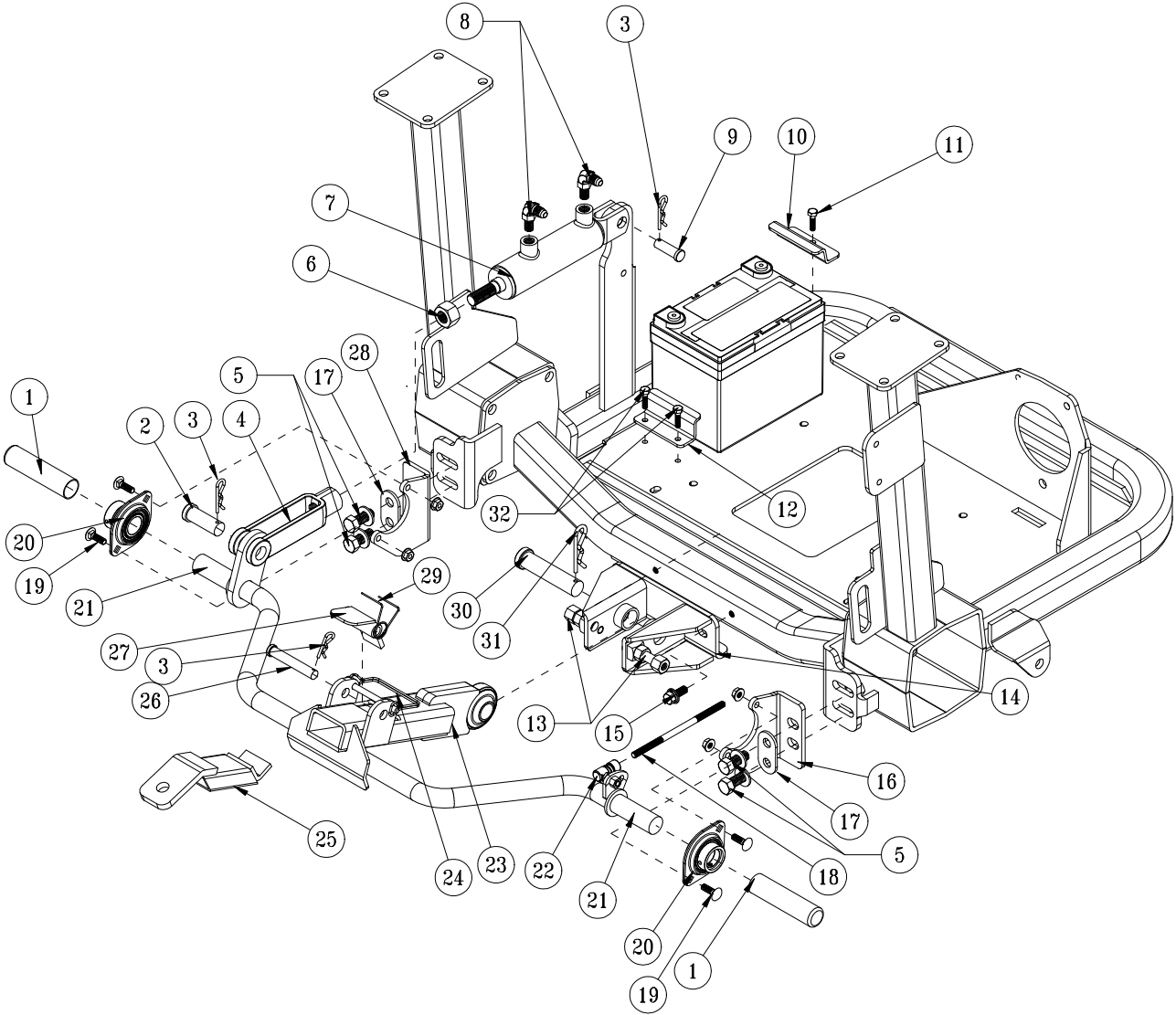

REAR RAKE LIFT PARTS LIST

REF#	PART#	DESCRIPTION	QUANTITY
1	15-019	Rubber Grip	2
2	HCP-34-200	Clevis Pin, $\frac{3}{4}$ x 2	1
3	HHP-18	Bridge Pin, $\frac{1}{8}$	3
4	42-040	Lift Linkage	1
5	HB-12-13-125	Hex Bolt, $\frac{1}{2}$ - 12 x $1\frac{1}{4}$	4
	HNFL-12-13	Flange Whiz-loc Nut, $\frac{1}{2}$ - 12	4
6	HNJ-34-16	Jam Nut , $\frac{3}{4}$ - 16	1
7	43-150	Hydraulic Cylinder	1
	43-150-01	Seal Kit	1
8	18-168	90° Elbow	2
9	HCP-12-150	Clevis Pin, $\frac{1}{2}$ - $1\frac{1}{2}$	1
10	45-334	Battery Clamp	1
11	HB-516-18-125	Hex Bolt, $\frac{5}{16}$ - 18 x $1\frac{1}{4}$	1
	HW-516	Flat Washer, $\frac{5}{16}$	1
12	45-335	Battery Hold-down	1
13	HSSHB-12-13-200	Button Socket Head Cap Screw	2
	HN-12-13	Hex Nut, $\frac{1}{2}$ -13	2
	HNCL-12-13	Center Nylon Lock Nut, $\frac{1}{2}$ - 13	2
14	43-140	Frame Mount	1
15	HB-38-24-100	Hex Bolt, $\frac{3}{8}$ - 24 x 1	2
	HW-38	Flat Washer, $\frac{3}{8}$	2
	HWL-38	Lock Washer, $\frac{3}{8}$	2
16	45-435	Pivot Bracket - RH	1
17	45-436	Rear Lift Washer	2
18	43-147	Speed Boss Rod	1
19	HBCL-516-18-100	Carriage Bolt, $\frac{5}{16}$ - 18 x 1	4
	HNFL-516-18	Flange Whiz-loc Nut, $\frac{5}{16}$ -18	4
20	13-391	Flange Bearing	2
21	45-114	Lift Bar	1
22	18-387	Quick Disconnect Ball Joints	1
23	43-141	Lift Arm	1
24	25-382	Lock Pin	1
25	43-143	Towing Hitch (OPTIONAL)	1
26	HCP-12-350	Clevis Pin, $\frac{1}{2}$ - $3\frac{1}{2}$	1
27	43-139	Lock	1
28	45-434	Pivot Bracket - LH	1
29	43-136	Torsion Spring	1
30	HCP-78-350	Clevis Pin, $\frac{7}{8}$ x $3\frac{1}{2}$	1
31	HHP-.177	Bridge Pin, .177 x $3\frac{3}{4}$	1
32	HB-516-18-100	Hex Bolt, $\frac{5}{16}$ - 18 x 1	2
	HNFL-516-18	Flange Whiz-loc Nut, $\frac{5}{16}$ -18	2

CENTER LIFT DRAWING

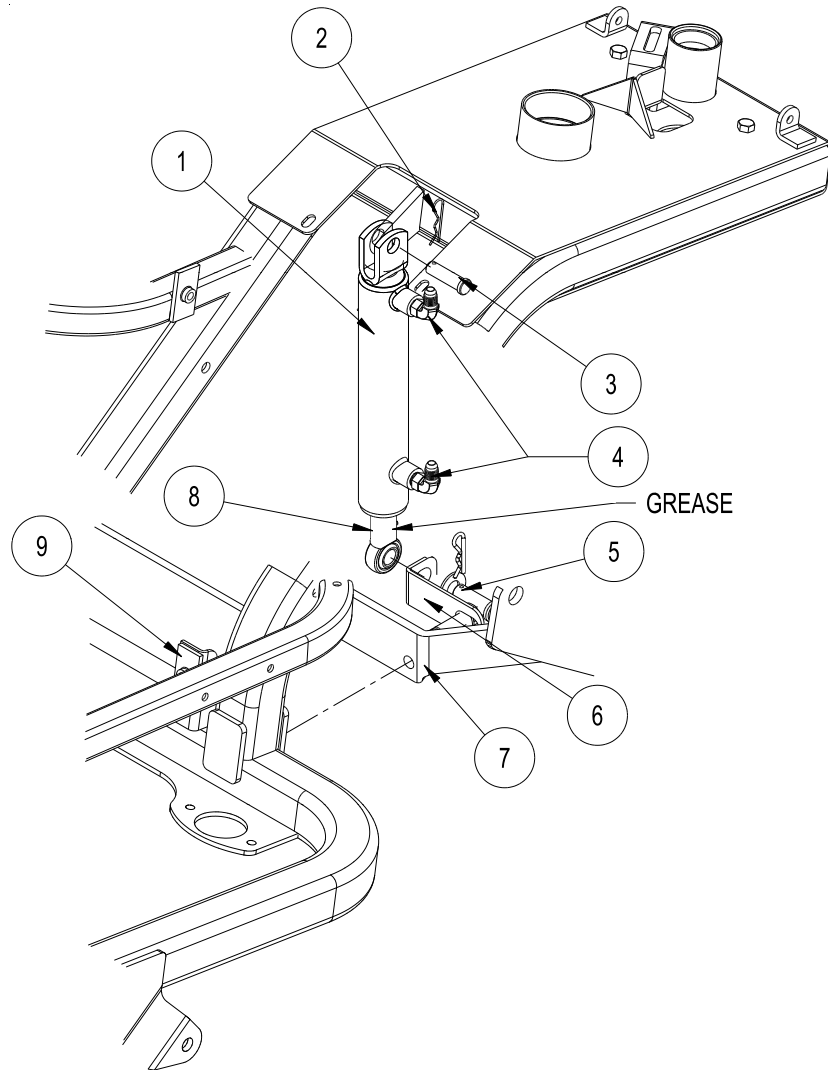

REF#	PART #	DESCRIPTION	QUANTITY
1*	10-554	Hydraulic Cylinder	1
2	HHP-18	Bridge Pin $\frac{1}{8}$	1
3	HCP-58-150	Clevis Pin $\frac{5}{8}$ - $1\frac{1}{2}$	1
4*	18-168	90° Elbow	2
5	HCP-58-200	Clevis Pin $\frac{5}{8}$ x 2	1
	HW-58	Flat Washer, $\frac{5}{8}$	1
	HHP-18	Bridge Pin $\frac{1}{8}$	1
6	45-153	Center Ram Holder	1
7	45-431	RH Floorboard Brace	1
8	18-154	Rod End	1
	HG-14-28-180	Grease Fitting $\frac{1}{4}$ - 28 x 180°	1
	HNJ-58-18	Jam Nut $\frac{5}{8}$ - 18	1

13-769 2-BANK HYDRAULIC VALVE

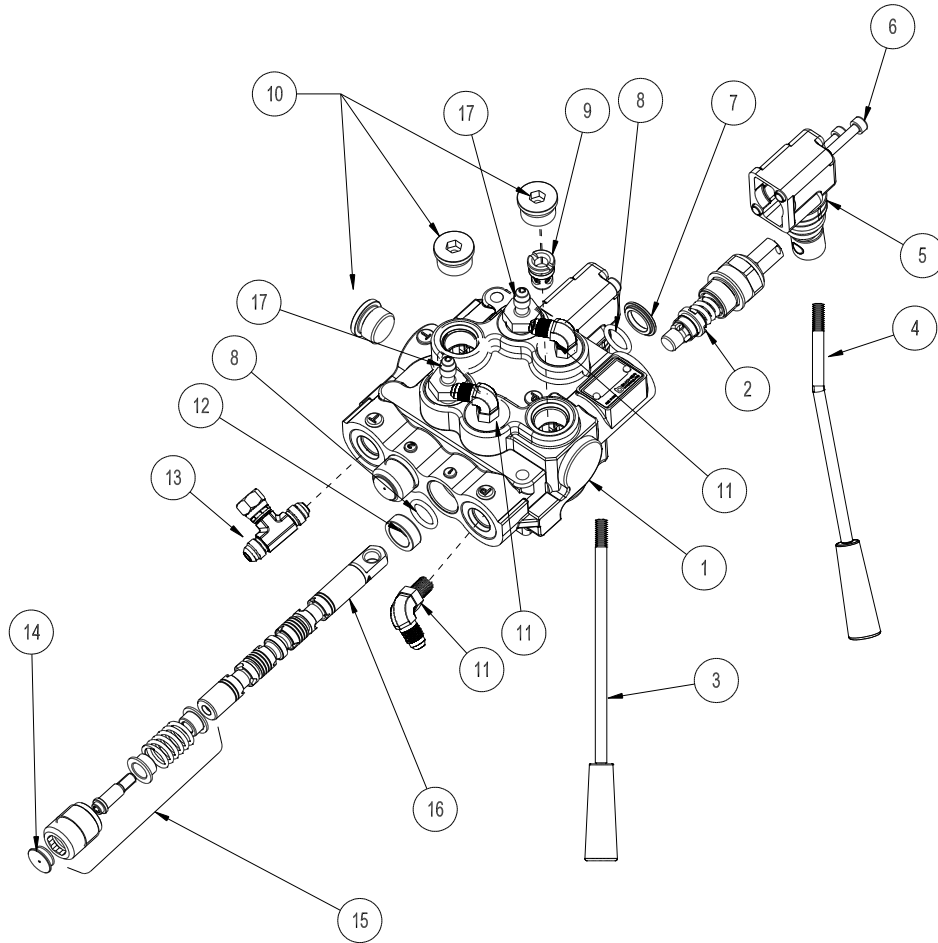

REF #	PART #	DESCRIPTION	QUANTITY
1*	78-415-01	Body (complete with spacer and check valve)	1
2*	78-415-02	Spool HDM10	1
3	78-417	Straight Handle	1
4	45-358	Bent Handle	1
5*	78-415-09	Lever Group HDS11	2
6*	78-415-10	Metric Socket Screw M5 x .8 x 45	4
7*	78-415-04	Flanged Washer HDM10	2
8*	78-415-03	O-Ring Seal	4
9*	78-415-12	Check Valve Assembly HDM12	1
10*	78-415-13	$\frac{3}{4}$ - 16 SAE 8 Screw Plug	3
11	18-185	Elbow	3
12*	78-415-05	Spacer	2
13	32-020	$\frac{3}{8}$ Tee	1
14*	78-415-08	Plug	2
15	78-415-11	Positioner	2
16*	78-415-06	A Type Spool HDS11	2
17	18-241	Adapter, $\frac{1}{4}$ - $\frac{1}{2}$ SAE	3

* 13-769 2 - Bank Hydraulic Valve (includes all * items)

34-103 ORBITAL DRAWING

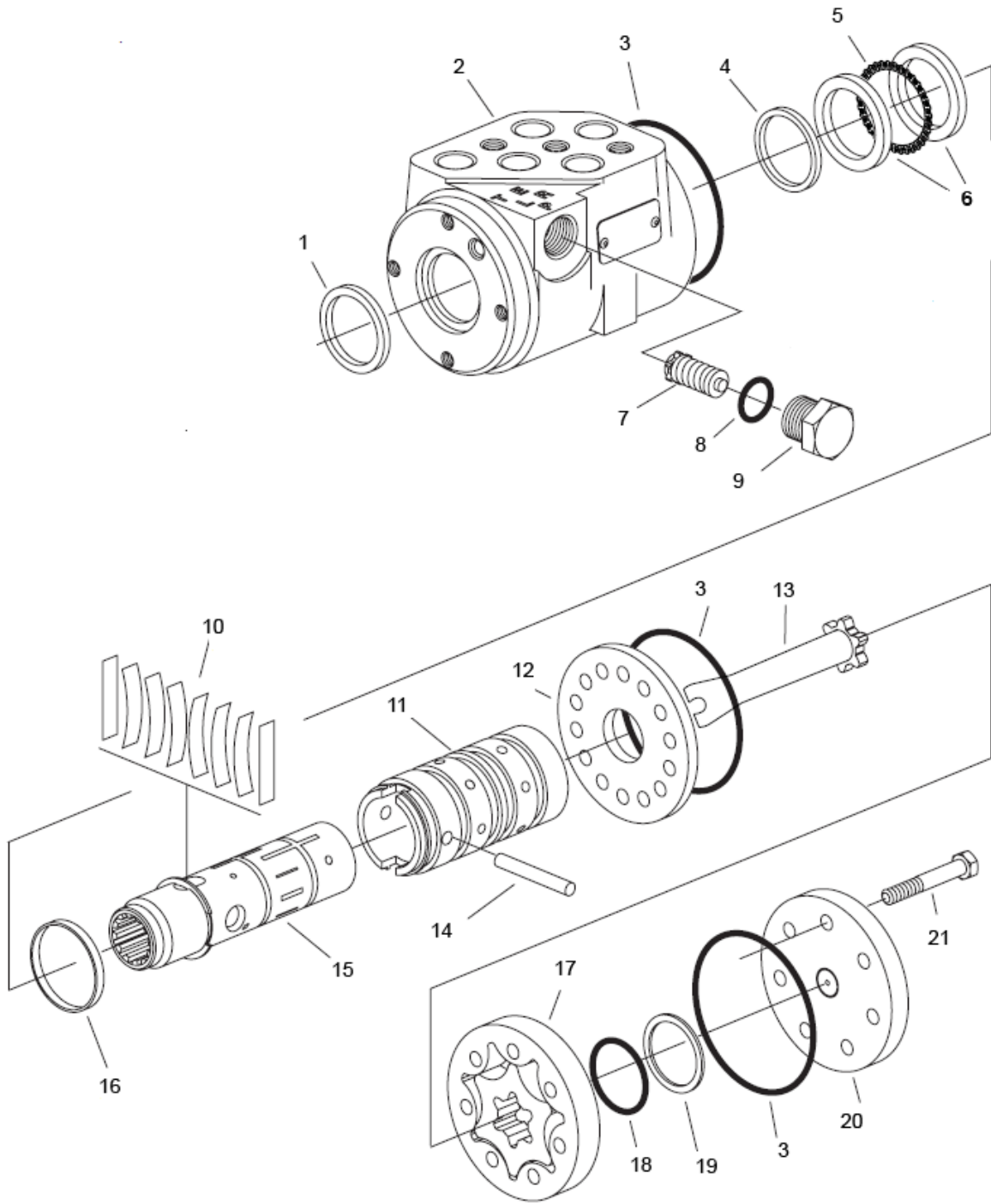

Parts

34-103 ORBITAL PARTS LIST

REF #	PART #	DESCRIPTION	QUANTITY
1**		Dust Seal	1
2		Housing	1
3**		O-Ring Seal	3
4**		Quad Seal	1
5	10-576-03	Thrust Bearing	1
6	10-576-02	Bearing Race	2
7		Manual Steering Relief Valve	1
8**		O-ring	1
9		Plug	1
10‡		Standard Torque Centering Springs	1
11		Sleeve	1
12	15-301-06	Wear Plate	1
13	10-576-01	Drive	1
14	15-301-08	Drive Pin	1
15		Spool	1
16‡		Spring Retaining Ring	1
17	34-103-01	Gerotor	1
18**		O-Ring	1
19**		Seal Ring	1
20	15-301-03	End Cap	1
21	10-576-06	Cap Screw	7
**	15-301-01	Seal Kit	1
‡	15-301-15	Centering Spring Kit	1

15-301 ORBITAL SPECIFICATIONS

Inlet Relief Valve Setting	1020 psi (70 bar)
Nominal Flow	3 gpm (11lpm)
Displacement	6.1 cu. in/ R (100 cu cm/R)
Check Valve for Manual Steering	Yes
Return Pressure Rating	145 psi (10 bar) Maximum
Fluid	SAE 10W-40 API Service SJ or higher Motor Oil
Ports	⁹ / ₁₆ - 18 SAE O-Ring 4 Ports

45-067 FRONT WHEEL MOTOR

Service

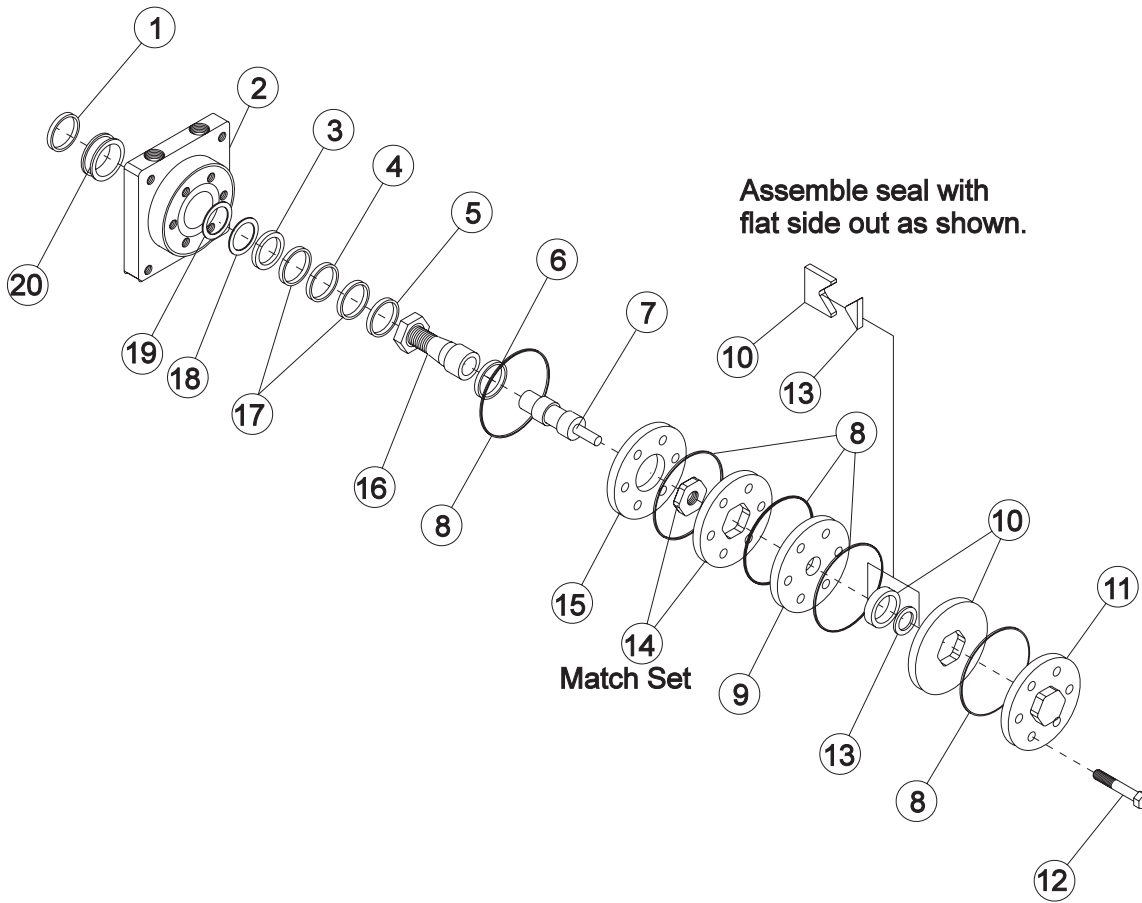

REF#	PART#	DESCRIPTION	QUANTITY
1*		Water & Dirt Seal	1
2		Service Housing Assembly	1
3*		Inner Seal	1
4	13-032-27	Thrust Bearing	1
5	13-032-28	Inner Bearing	1
6	13-032-29	Thrust Bearing	1
7	13-032-30	Drive Link	1
8*		Ring Seal	5
9	13-032-31	Manifold	1
10	13-032-32	Commutator Assembly (matched set)	1
11		End Cover	1
12	14-134	Bolt	7
13*		Commutator Seal (matches with #10)	1
14	13-032-34	Rotor Set (matched set)	1
15	14-399-06	Plate Wear	1
16	13-032-36	Coupling Shaft	1
	HWK-516-100	Woodruff Key $\frac{5}{16}$ x 1	1
	14-265	Nut 1 - 20	1
17	13-032-37	Thrust Washer	2
18*		Backup Washer	1
19*		Backup Washer	1
20	13-032-38	Outer Bearing	1
*	14-080	Seal Kit	1

43-241/43-242 REAR WHEEL MOTOR (7.5 C.I.) DRAWING

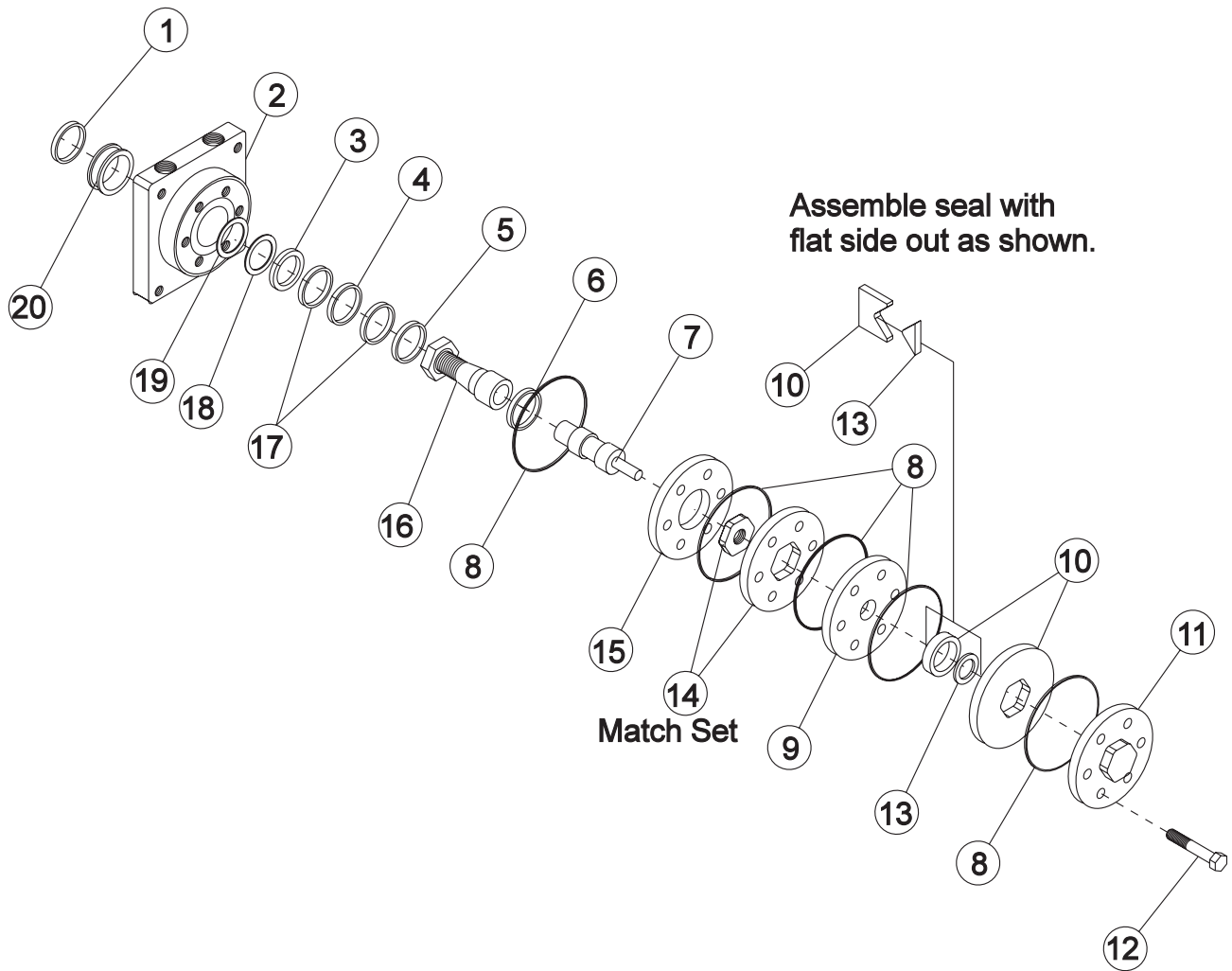

Parts

43-241/43-242 REAR WHEEL MOTOR (7.5 C.I.) PARTS LIST

REF#	PART#	DESCRIPTION	QUANTITY
1*		Water & Dirt Seal	1
2		Service Housing Assembly (Includes Ref 4, 5, 17(2 req'd) and 20)	1
3*		Inner Seal	1
4	13-032-27	Thrust Bearing	1
5	13-032-28	Inner Bearing	1
6	13-032-29	Thrust Bearing	1
7	13-615-03	Drive Link	1
8*		Ring Seal	5
9	13-032-31	Manifold	1
10	13-032-32	Commutator Assembly (matched set)	1
11		End Cover	1
12	13-615-01	Hex Bolt	7
13*		Commutator Seal (matches with #10)	1
14	13-615-02	Rotor Set (matched set)	1
15	13-032-35	Plate Wear	1
16	13-615-04	Coupling Shaft	1
	HWK-516-100	Woodruff Key $5/16 \times 1$	1
	14-265	Nut 1 - 20	1
17	13-032-37	Thrust Washer	2
18*		Backup Washer	1
19*		Backup Washer	1
20	13-032-38	Outer Bearing	1
*	14-080	Seal Kit	1

Parts

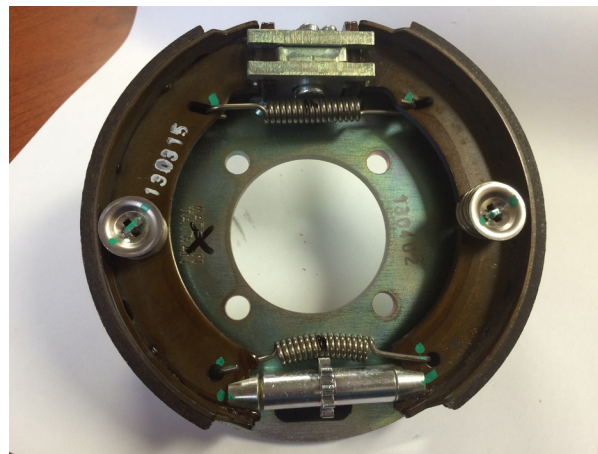

43-241-01 Brake Assembly

45-373 PISTON PUMP DRAWING

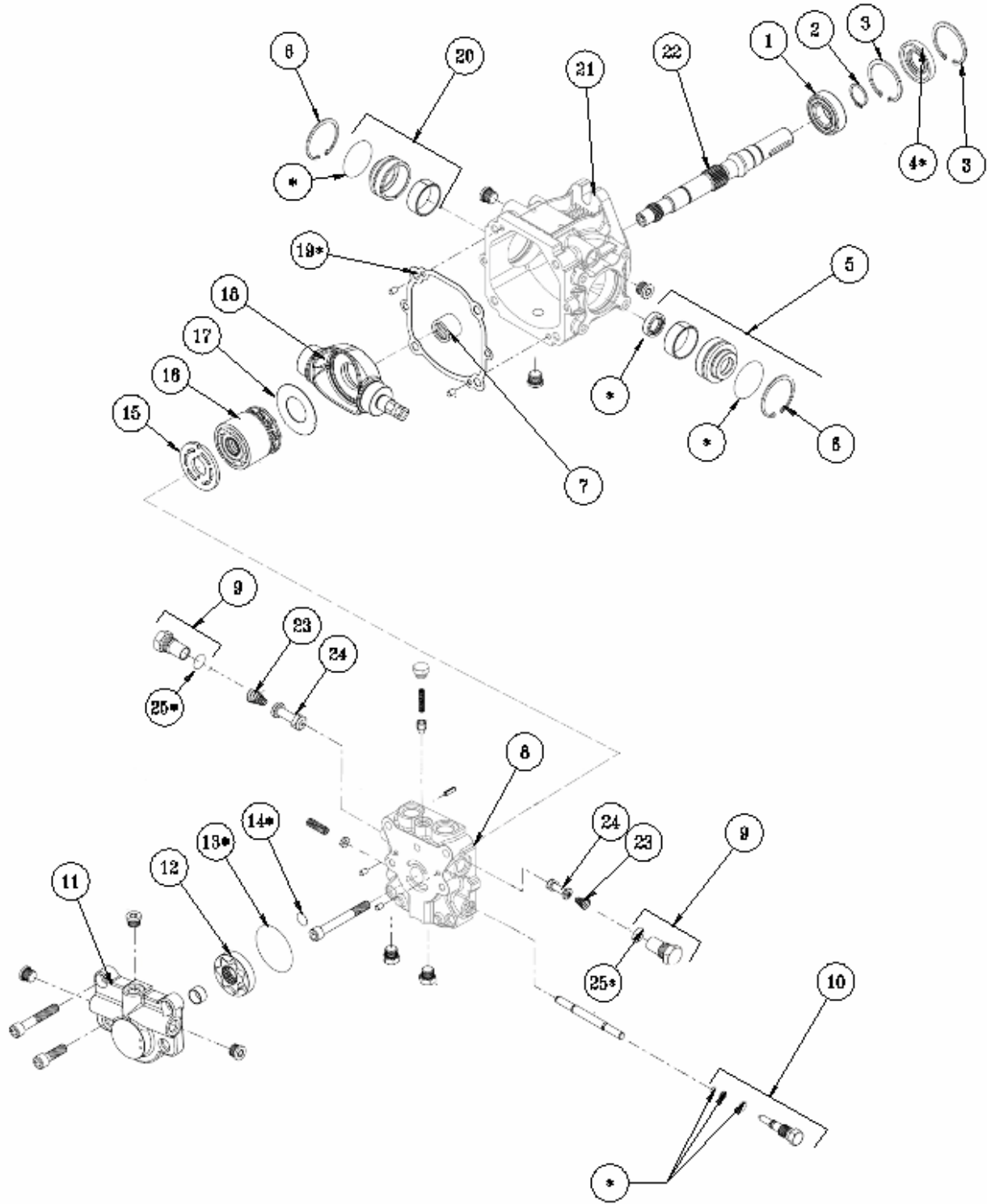

Parts

C

45-373 PISTON PUMP PARTS LIST

REF#	PART#	DESCRIPTION	QUANTITY
1	45-373-02	Ball Bearing	1
2	45-373-03	Retaining Ring	1
3	45-373-04	Retaining Ring	2
4*		Lip Seal	1
5	45-373-05	Journal Bearing Carrier Assembly	1
6	45-373-06	Retaining Ring	1
7	45-373-07	Needle Bearing	1
8	45-373-08	End Cap	1
9	45-373-09	Plug Assembly	2
10	45-373-10	By-Pass Valve Assembly	1
11	45-373-11	Charge Pump Housing	1
12	45-373-12	Gerotor Assembly	1
13*		O-ring	1
14*		O-ring	1
15	45-373-13	Valve Plate CCW	1
16	45-373-14	Cylinder Block kit	1
17	45-373-15	Thrust Plate	1
18	45-373-16	Swash Plate, Axial Offset	1
19*		Gasket	1
20	45-373-17	Journal Bearing Carrier Assembly	1
21	45-373-19	Housing	1
22	45-373-18	Pump Shaft	1
23	45-373-20	Compression Spring	2
24	45-373-21	Poppet, Check Valve	2
25*	45-373-22	Oring	2
*	45-373-01	Overhaul Seal Kit	

DECAL LIST

This is a list of decals located on the Sand Star. Part number, description and location will help in reordering decals.

REF#	PART#	DESCRIPTION	QTY
1	16-088	Decal, Moving Parts Hot (on belt guard)	1
2	25-277	Decal, Battery Warning	1
3	25-286	Decal, Pinch Point	2
4	25-298	Decal, Warning Hot	1
5	25-337	Decal, Speed Boss Hang Tag	1
6	25-352	Decal, Bypass Valve (on pump)	1
7	25-354	Decal, Tire Pressure 5PSI	3
8	25-371	Decal, Diesel	2
9	25-372	Decal, 4" Smithco Star	1
10	25-370	Decal, 88 dBA	1
11	25-386	Decal, Lift & Lower	1
12	27-077	Decal, Smithco Round	1
13	30-117	Decal, Sulfur Fuel	1
14	45-196	Decal, Sand Star V	2
15	45-427	Decal, Dash Panel	1
16	51-184	Decal, Park Brake	1

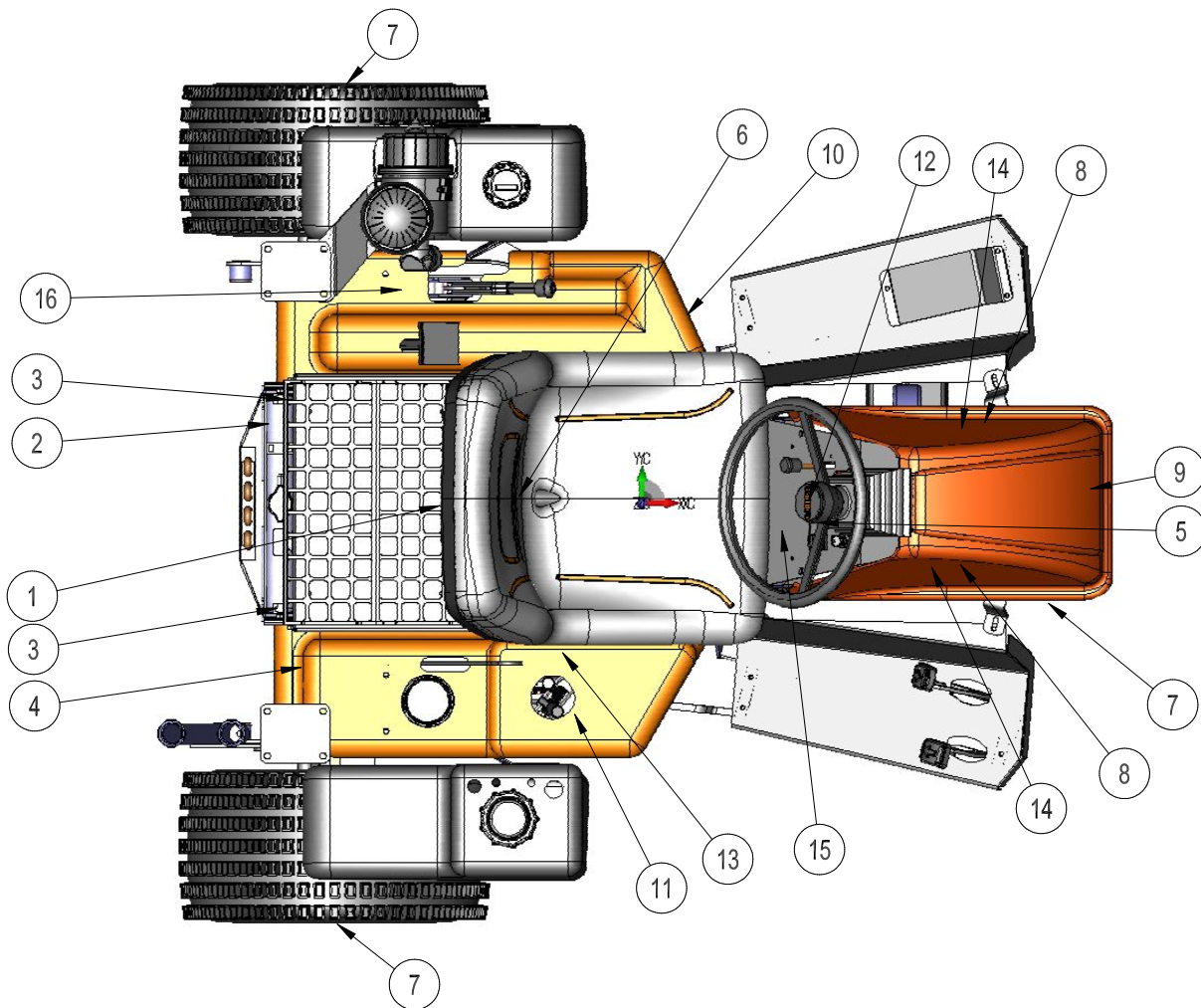

Reference

QUICK REFERENCE REPLACEMENT PARTS

REPLACEMENT FILTERS

23-031	Hydraulic Oil Filter	
42-076-03	Air Filter Element Fender Mounted	
42-834-03	Safety Filter Element Fender Mounted	
17-043	Fuel Filter Element	Kubota# 15881-97011
17-255	Oil Filter Cartridge	

SEAL KITS

45-373	Variable Pump	
45-373-01	Overhaul Kit	
43-241 & 43-242	Wheel Motor (Rear)	
14-080	Seal Kit	
45-067	Wheel Motor (Front)	
14-080	Seal Kit	
13-769	2-Bank Valve	
78-415-03	Seal Kit	
10-554	Hydraulic Cylinder (Center Attachment Lift)	
14-529	Seal Kit	
43-150	Hydraulic Cylinder (Rear Rake Lift)	
43-150-01	Seal Kit	
10-554	Steering Hydraulic Cylinder	
14-529	Seal Kit	
34-103	Orbitol	
15-301-01	Seal Kit	

FLUIDS

Engine Oil	Refer to Engine Manual
Hydraulic Fluid	SAE 10W-40 API Service SJ or higher Motor Oil

OTHER PARTS

48-265	Turf Tire and Wheel
--------	---------------------

45-004 ROPS DRAWING

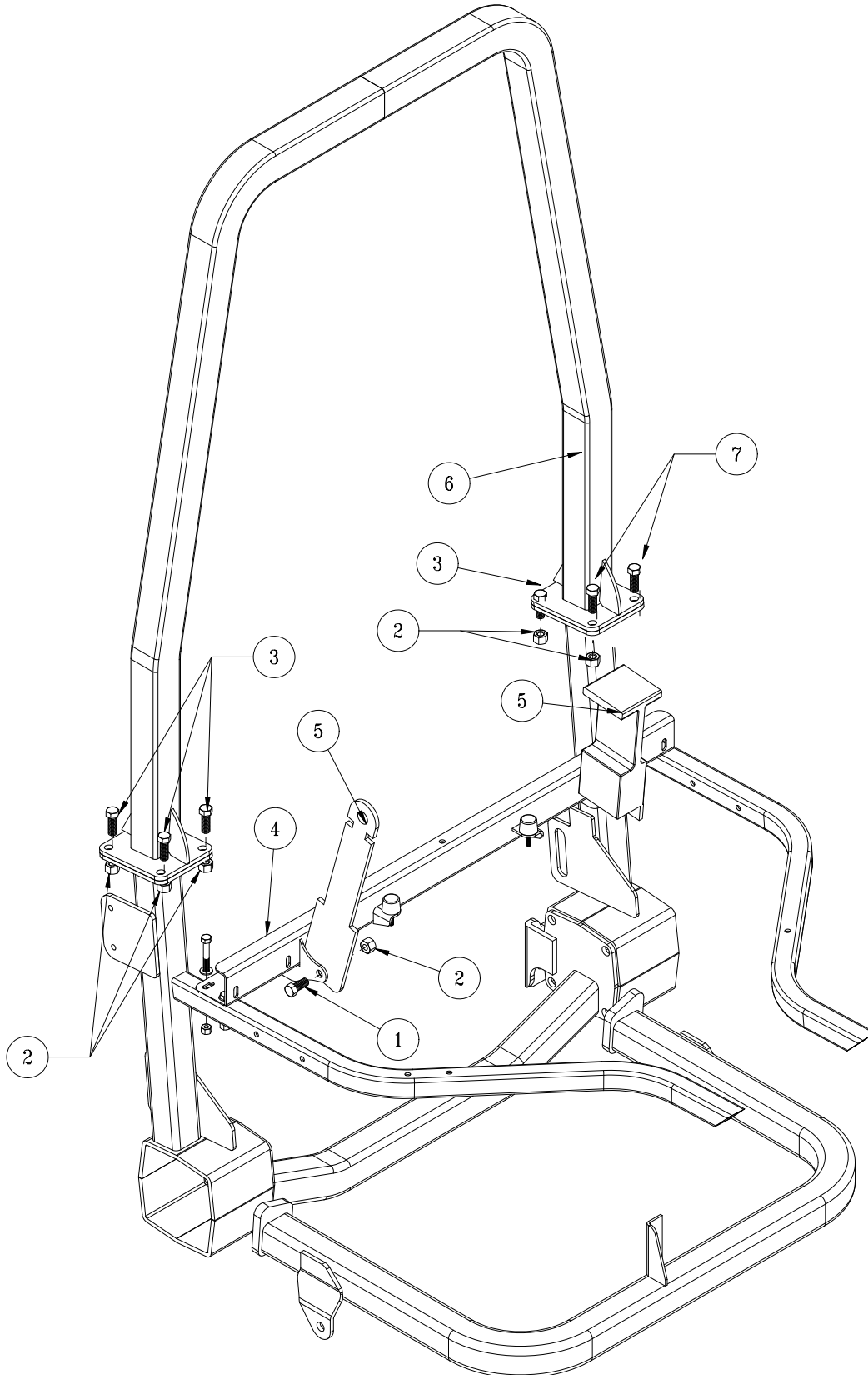

Accessories

45-004 ROPS PARTS LIST

REF#	PART#	DESCRIPTION	QUANTITY
1	HB-716-14-100	Hex Bolt, $\frac{7}{16}$ - 14 x 1	2
2	HNTL-716-14	Nylon Lock Nut, $\frac{7}{16}$ - 14	8
3	HB-716-14-125	Hex Bolt, $\frac{7}{16}$ - 14 x $1\frac{1}{4}$	6
4	45-082	Seat Belt Brace	1
5	76-198-03	Seat Belt	1
6	45-060	Roll Bar	1
7	HB-716-14-150	Hex Bolt, $\frac{7}{16}$ - 14 x $1\frac{1}{2}$	2

INSTALLATION INSTRUCTIONS

The Following instructions apply to all Sand Star Machines.

1. Line up the mount plate on the roll bar to the square mounting plate by the seat. Mount leaning forward, towards front of machine.
2. Place four 1-1/4" Hex Bolts in the right mount plate holes and tighten. Place two 1-1/4" Hex Bolts on left rear and two 1-1/2" Hex Bolts on left front. Hex Bolts are longer in the left front to accommodate remote air cleaner option.
3. If your machine has a remote air cleaner you will have to remove the 2 Hex Bolts holding the air filter mount. Place the roll bar on top of the air filter mount. Replace Hex Bolts and tighten down.
4. Mount seat belts onto seat belt brace using 1" Hex Bolts. The strap goes on the right side and the lock goes on the left side.
5. Tighten all hardware.

ROPs are certified to meet ISO 21299 and restraints meet OSHA 1928.51

45-016 LIGHT KIT DRAWING

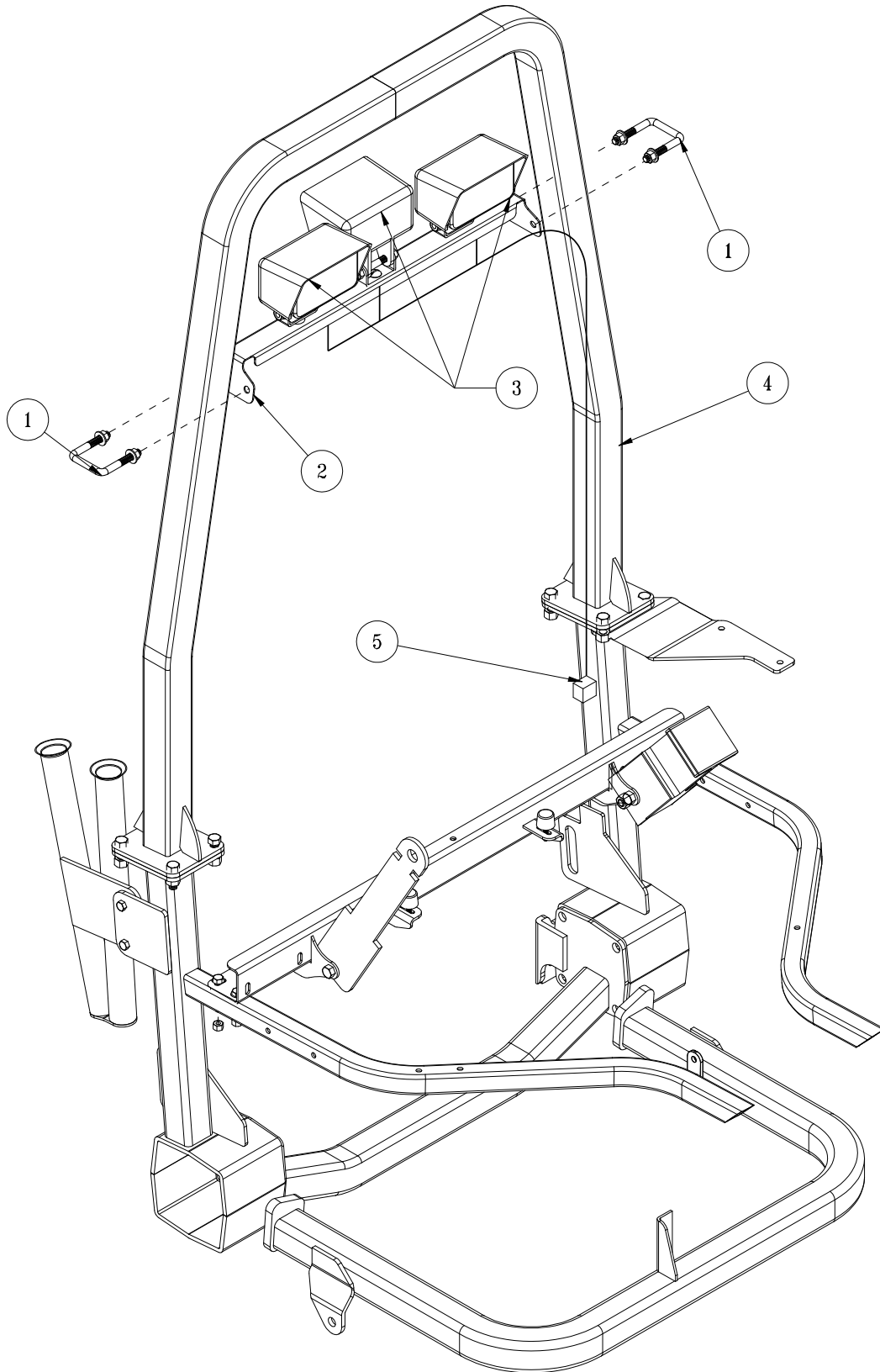

45-016 LIGHT KIT PARTS LIST

REF#	PART#	DESCRIPTION	QUANTITY
1	17-537	Square U-Hex Bolt	2
2	45-081	Light Bar	1
3	34-201	Light	3
4	45-004	Roll Bar Kit	1
5	43-505	Light Wire Harness	1

INSTALLATION INSTRUCTIONS

45-004-K ROPs Kit is required for Light Kit on all Sand Star Machines.

1. Mount lights to light bar. Outside two facing forwards and center light facing to the rear.
2. Using the square u-Hex Bolts, mount light bar assembly to the roll bar.
3. Tighten u-Hex Bolts down and make sure light bar and lights are secure.
4. Tighten all hardware.
5. Center toggle switch is wired for lights via the main machine wire harness. The plug for the light wire harness is zip tied to the ROPs post (Ref 5). Hook light wire harness from lights to the plug on the ROPs rear post.
6. Use the tie straps provided to secure the light wire harness to the roll bar and the light bar.
7. Test lights.

45-390 LIGHT KIT

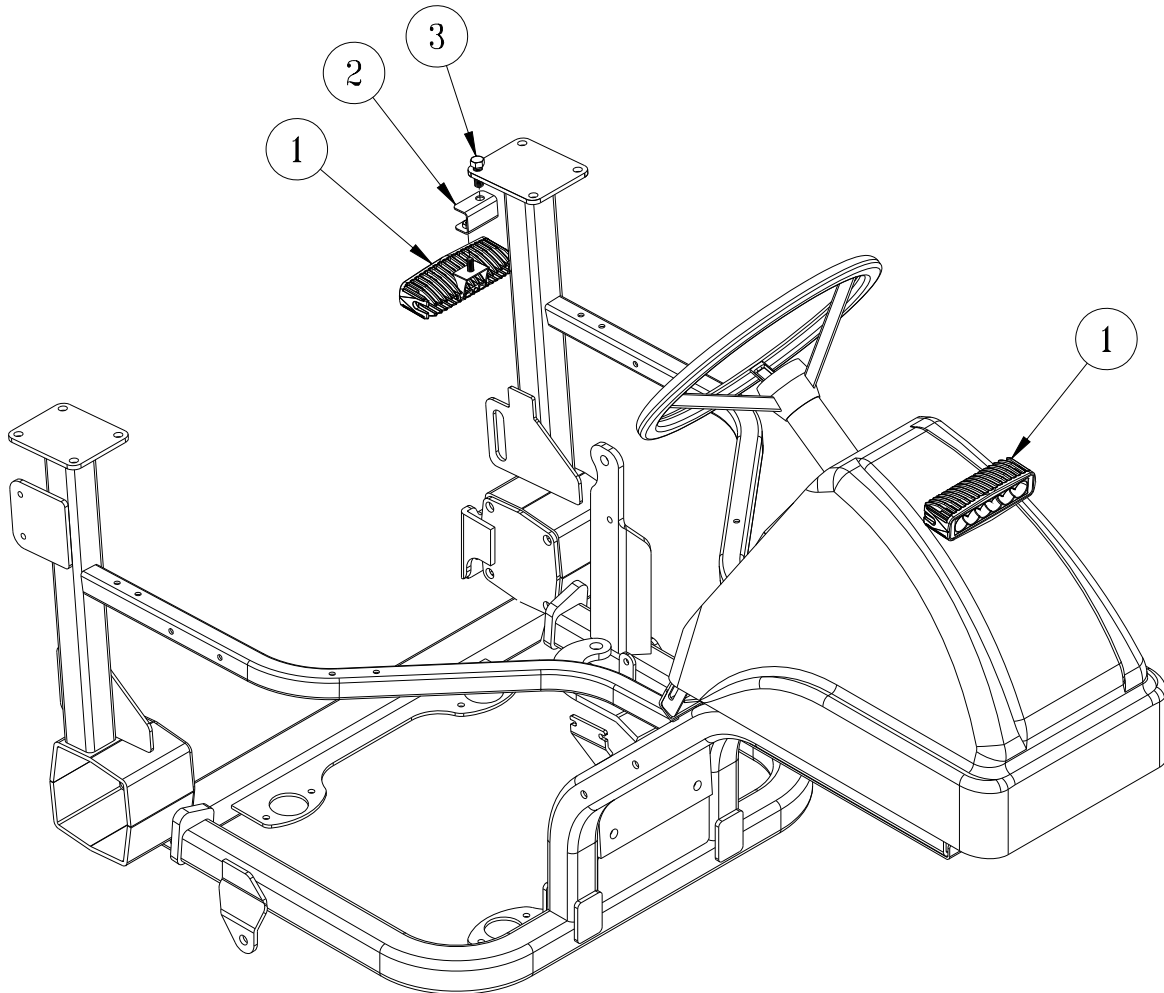

REF#	PART#	DESCRIPTION	QUANTITY
1	10-732	LED Light	2
	45-393	Wire Harness	1
2	45-389	Rear Light Bracket	1
3	HB-716-14-125	Hex Bolt, $\frac{7}{16}$ - 14 x $1\frac{1}{4}$	1
	HNTL-716-14	Lock Nut, $\frac{7}{16}$ - 14	1

INSTALLATION INSTRUCTIONS

1. Remove the nosecone from the machine.
2. Drill a $\text{Ø}5/16$ " hole, centered and 3" down from the top of the nosecone. Drill another $\text{Ø}5/16$ " hole $3/4$ " further down.
3. Install Light Wire Harness on frame with sealed connector at left rear. Connect to main harness and secure using included cable ties.
4. Run the wires through the lower hole. Bolt the light in the top hole. Connect to Light Wire Harness. Replace nosecone.
5. Use the included $\frac{7}{16}$ - 14 Hex Bolt and Lock Nut to mount the Rear Light Bracket to the underside of the Roll Bar mounting plate.
6. Mount the Light to the Light Bracket. Connect wires to Light Wire Harness
7. Test lights.

ACCESSORIES

Front Accessories	A
13-765 Single Bank Valve	2
45-206 40" Hydraulic Sand Plow	4
45-009 40" Aluminum Manual Sand Plow	8
45-019 60" Aluminum Manual Plow.....	10
45-179 40" Adjustable Angle Plow.....	12
45-180 60" Adjustable Angle Plow.....	14
Center Attachments	B
45-014 Weed Cultivator.....	16
45-006 Sand Cultivator.....	18
45-008 Sand Cultivator w/ Spring Tine	20
45-012 Construction Leveling Blade.....	22
45-013 Sand Cultivator w/ Castor Wheels.....	24
45-007 Infield Scarifier (vertical blades)	26
45-360 Infield Scarifier (vertical long blades)	28
45-011 Infield Scarifier (chisel blades).....	30
45-195 Grader Blade Kit.....	32
45-175 Adjustable Disc Edger	34
45-177 Nail Scarifier	36
Rear Attachments	C
42-391Q 72" Pro-Brush Tournament Rake	38
43-392Q 84" Pro-Brush Tournament Rake	42
42-130Q 84" Mild Steel Rake	46
42-132Q 72" Mild Steel Rake	50
13-758Q Max Flex Sand Rake	54
45-503 84" Pro Rake	56
45-511 Serrated Rubber Flex Rake.....	58
13-740 Brush Attachment	60
13-684 Brush Attachment	62
13-298Q Fan Rake	64
13-319 Fan Rake Kit.....	64
26-007Q Professional Field Finisher	66
43-002Q Flex Action Field Finisher w/ Brush	68
26-008Q Flex Action Field Finisher	72
43-043 Finishing Brush.....	74
43-008 Drag Mat Kit	76
45-176 Drag Mat with Finisher Brush	78
45-010 Box Grader	80
42-586Q Green Star RBS Main Frame	82
42-581 Green Star RBS Roller	84
42-585 Green Star RBS Brush	86
42-582 Green Star RBS Spiker	88
43-009 Coco Mat Finisher	90
43-170 Rahn Groomer.....	92
41-501 Typhoon.....	96
Warranty	

Front Attachment

Center Attachment

Rear Attachment

13-765 SINGLE BANK HYDRAULIC VALVE DRAWING

Front Attachment

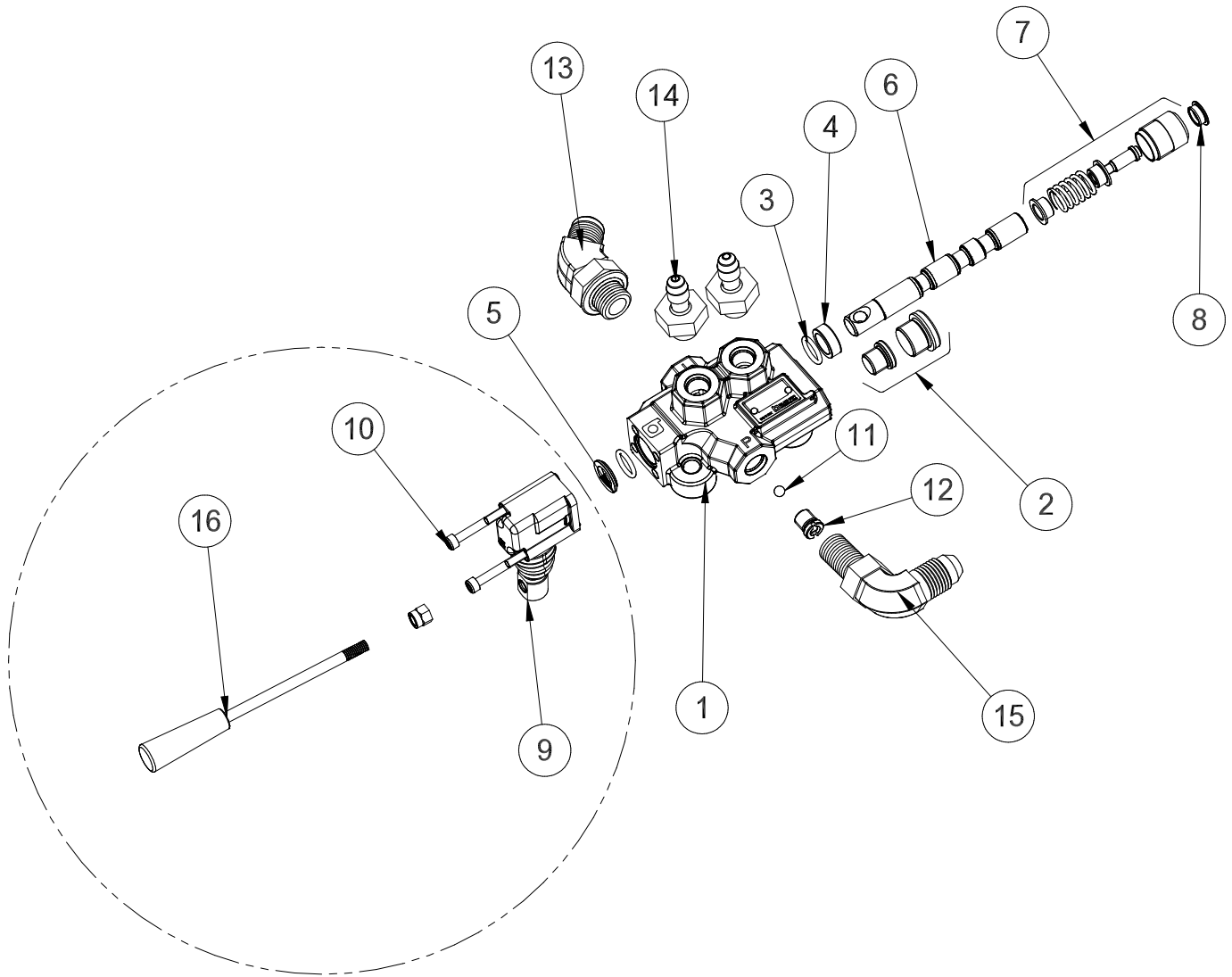

Remove screws (Ref # 10) rotate 180°
so handle comes out port side.

13-765 SINGLE BANK HYDRAULIC VALVE PARTS LIST

REF #	PART #	DESCRIPTION	QUANTITY
1*		Actuator Housing Assembly	1
2*	13-731-02	Valve Plug	1
3*†	78-415-03	O-Ring Seal	2
4*†	78-415-05	Spacer	3
5*	78-415-04	Flanged Washer HDM10	3
6*	13-731-03	Spool	1
7*	78-415-11	Positioner	1
8*	78-415-08	Plug	3
9*	78-415-09	Lever Group HDS11	3
10*	78-415-10	Metric Socket Screw M5 x .8 x 45	2
11*	13-731-04	1/4" Ball	1
12*†	13-731-05	Check Valve	1
13	18-341	45° Elbow	1
14	18-241	3/8 SAE Adapter	2
15	18-185	3/8 - 90° Elbow	1
16	78-417	Straight Handle	1
	78-417-01	Tapered Knob	1

* 13-765 Single Bank Hydraulic Valve (includes all * items)

45-206 HYDRAULIC SAND PLOW PARTS LIST

REF#	PART#	DESCRIPTION	QUANTITY
1	45-126	Ram Mount	1
2	HCP-58-150	Clevis Pin, $\frac{5}{8}$ x $1\frac{1}{2}$	1
3	HHP-18	Bridge Pin, $\frac{1}{8}$	4
4	13-406	Hydraulic Cylinder	1
5	18-168	45° Elbow	2
6	45-092	Aluminum Sand Plow Blade	1
	45-321	Steel Sand Plow Blade	1
7	18-154	Rod End	1
	HNJ-58-18	Jam Nut, $\frac{5}{8}$ - 18	1
8	HB-38-16-100	Hex Bolt, $\frac{3}{8}$ - 16 x 1	4
	HNFL-38-16	Flange Whiz-loc Nut, $\frac{3}{8}$ - 16	4
9	13-167	Wear Blade	1
10	HB-38-16-125	Hex Bolt, $\frac{3}{8}$ - 16 x $1\frac{1}{4}$	2
	HW-38	Flat Washer, $\frac{3}{8}$	2
	HWL-38	Lock Washer, $\frac{3}{8}$	2
	HN-38-16	Nut, $\frac{3}{8}$ - 16	2
11	HB-12-13-300	Hex Bolt, $\frac{1}{2}$ - 13 x 3	2
	HNTL-12-13	Nylon Lock Nut, $\frac{1}{2}$ - 13	2
12	HB-38-16-250	Hex Bolt, $\frac{3}{8}$ - 16 x $2\frac{1}{2}$	2
	HNTL-38-16	Nylon Lock Nut, $\frac{3}{8}$ - 16	2
13	HCP-12-150	Clevis Pin, $\frac{1}{2}$ x $1\frac{1}{2}$	2
14	45-100	Right Pusher Bar	1
15	45-125	Plow Crossbar	1
16	HCP-58-175	Clevis Pin, $\frac{5}{8}$ x $1\frac{3}{4}$	1
17	45-101	Left Pusher Bar	1
18	18-341	45° Elbow	4
19	45-359	Valve Mount	1
20	HB-516-18-100	Hex Bolt, $\frac{5}{16}$ - 18 x 1	2
	HNFL-516-18	Flange Whiz-loc Nut, $\frac{5}{16}$ - 18	2
21	78-417	Straight Handle	1
22	13-765	Single Bank Hydraulic Valve	1
23	45-362	Hose, 48"	2
24	45-361	Hose, 34 $\frac{1}{2}$ "	1
25		2-Bank Valve (on machine)	1
26	45-068	Hose (on machine to pump)	1
27	18-185	90 Elbow	1

45-206 HYDRAULIC SAND PLOW DRAWING

Front Attachment

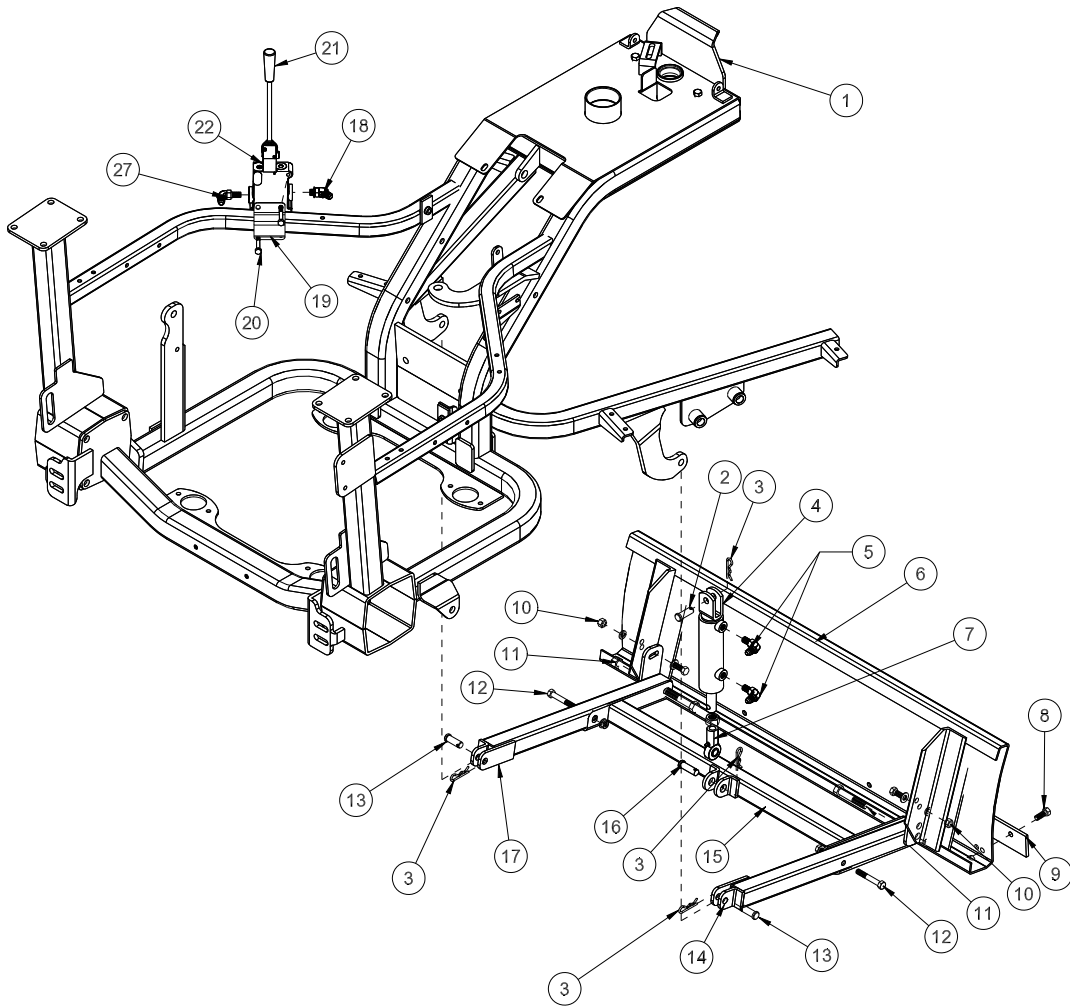

HYDRAULIC VALVE PLUMBING DRAWING

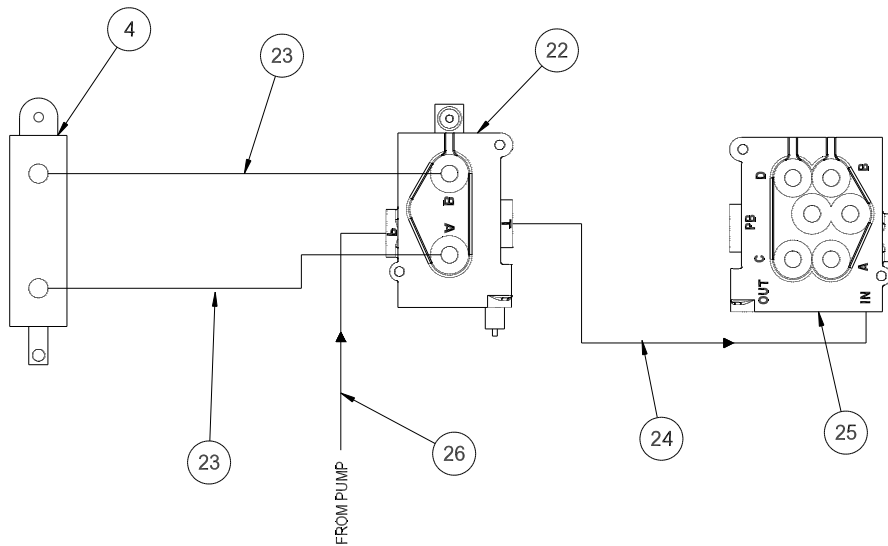

45-206 HYDRAULIC SAND PLOW INSTRUCTIONS

REMOVE FIBERGLASS FENDERS AND NOSE FOR EASIER ACCESS.

HYDRAULIC VALVE ASSEMBLY

1. Check orientation of the valve control. Valve control should face outlet ports. If it doesn't, remove the two allen screws from control, rotate 180° and reinstall.
2. Thread two, straight adapters into the single bank valve (Ref# 22), one each in the **A** outlet port, **B** outlet port. Thread one 45° Elbow (Ref # 18) into the **OUT** port (T). Thread one $\frac{3}{8}$ straight thread elbow fittings (Ref # 27) into the **IN** port (P). Reference *Single Bank Hydraulic Valve Drawing* for a detailed view of the valve.
3. Mount the single bank hydraulic valve (Ref# 22) on the left frame rail using the valve mount plate (Ref# 19) using the two $\frac{5}{16}$ - 18 x 1 Hex Bolts (Ref# 20). Secure with the two $\frac{5}{16}$ - 18 Flange Whiz-loc Nuts. Connect the straight handle (Ref# 21) to the valve facing up.
4. Temporarily reinstall left fender over valve. Use a $\frac{1}{4}$ " screwdriver or rod inserted through the threaded hole in the valve control to mark the bottom of the fender for drilling. Drill a $\frac{1}{8}$ " hole through the fender for a pilot hole. Drill pilot hole out to $1\frac{1}{2}$ " using a hole saw.

HYDRAULIC PLOW CYLINDER

1. Assemble the ram mount (Ref# 1) to the main frame using the two studs that are welded to the frame and below the front of the console.
2. Thread two, $\frac{3}{8}$ straight thread elbow fittings (Ref# 5) into the ports on the hydraulic cylinder (Ref# 4). Make sure the fittings on the hydraulic cylinder are pointing towards the machine.
3. Install rod end (Ref# 7) onto cylinder with $\frac{5}{8}$ jam nut.
4. Connect the hydraulic cylinder to the ram mount (Ref# 1) using $\frac{5}{8}$ x $1\frac{1}{2}$ Clevis Pin (Ref# 2) and $\frac{1}{8}$ " bridge pin (Ref# 3).

HYDRAULIC HOSES

1. Disconnect the negative (-) ground battery cable from the battery. Place a drain pan under the valve on the machine. **ENGINE MUST BE COOL BEFORE DISCONNECTING THE HOSES.**
2. Disconnect the hose (Ref# 26) from the **IN** port on the 2-bank valve (Ref# 25) and reconnect to the **"P"** port on the single bank valve (Ref# 22).
3. Next connect the 34.5" hose (Ref# 24) from the **"T"** port on the single bank valve (Ref# 22) to the **IN** port on the two bank valve (Ref# 25).
4. Route one 48" hose (Ref# 23) from the **B** port on the single bank hydraulic valve to the top port on the hydraulic cylinder. Route the other 48" hose (Ref# 23) from the **A** port on the single bank hydraulic valve to the bottom port on the cylinder. **NOTE: 90° end of hose hooks to the single bank valve.** Route both hoses, under the dash and over front frame.

PLOW ASSEMBLY

1. Assemble pusher bars (Ref# 14 and 17) to plow blade (Ref# 6) using one $\frac{3}{8}$ -16 x $1\frac{1}{4}$ Hex Bolt (Ref# 10) and one $\frac{3}{8}$ -16 x 3 Hex Bolt (Ref# 11) per pusher bar. There are 2 holes to Hex Bolt (Ref# 10) hardware in. Using hole **closest to the blade will result in a shallow cut**, whereas using the hole **furthest from the blade will result in a deeper cut**. The slot on the pusher bar is for a more fine tuned adjustment.
2. Assemble the plow cross tube (Ref# 15) to the front pusher bars (Ref# 14 and 17) using $\frac{3}{8}$ - 16 x $2\frac{1}{2}$ Hex Bolts and Nylon Lock Nuts (Ref# 12).
3. Using a $\frac{5}{8}$ x $1\frac{3}{4}$ clevis pin (Ref# 16) and $\frac{1}{8}$ " bridge pin (Ref# 3). Mount the hydraulic cylinder (Ref# 4) to the plow crossbar (Ref# 15).
4. Slide the plow/pusher bar assembly under machine and connect to machine. Secure using $\frac{1}{2}$ x $1\frac{1}{2}$ clevis pins (Ref# 13) and $\frac{1}{8}$ " bridge pins (Ref# 3).
5. Reconnect the negative (-) ground battery cable to battery.
6. Make sure that everything is clear of the machine. Start the machine, work the valve so that the plow will both raise and lower. Also, do this with both the attachment lift and the rake lift. Work the lift a number of times until all air works out of the plow circuit and the cylinder works smoothly. At this time look for hydraulic leaks. If there are leaks, turn engine off and repair, start up and check again.
7. Check the hydraulic oil level. The level should be 2" to $2\frac{1}{2}$ " below the top of the tank. If more is needed, use SAE 10W-40 API service SG motor oil.

45-009 ALUMINUM 40" SAND PLOW DRAWING

Front Attachment

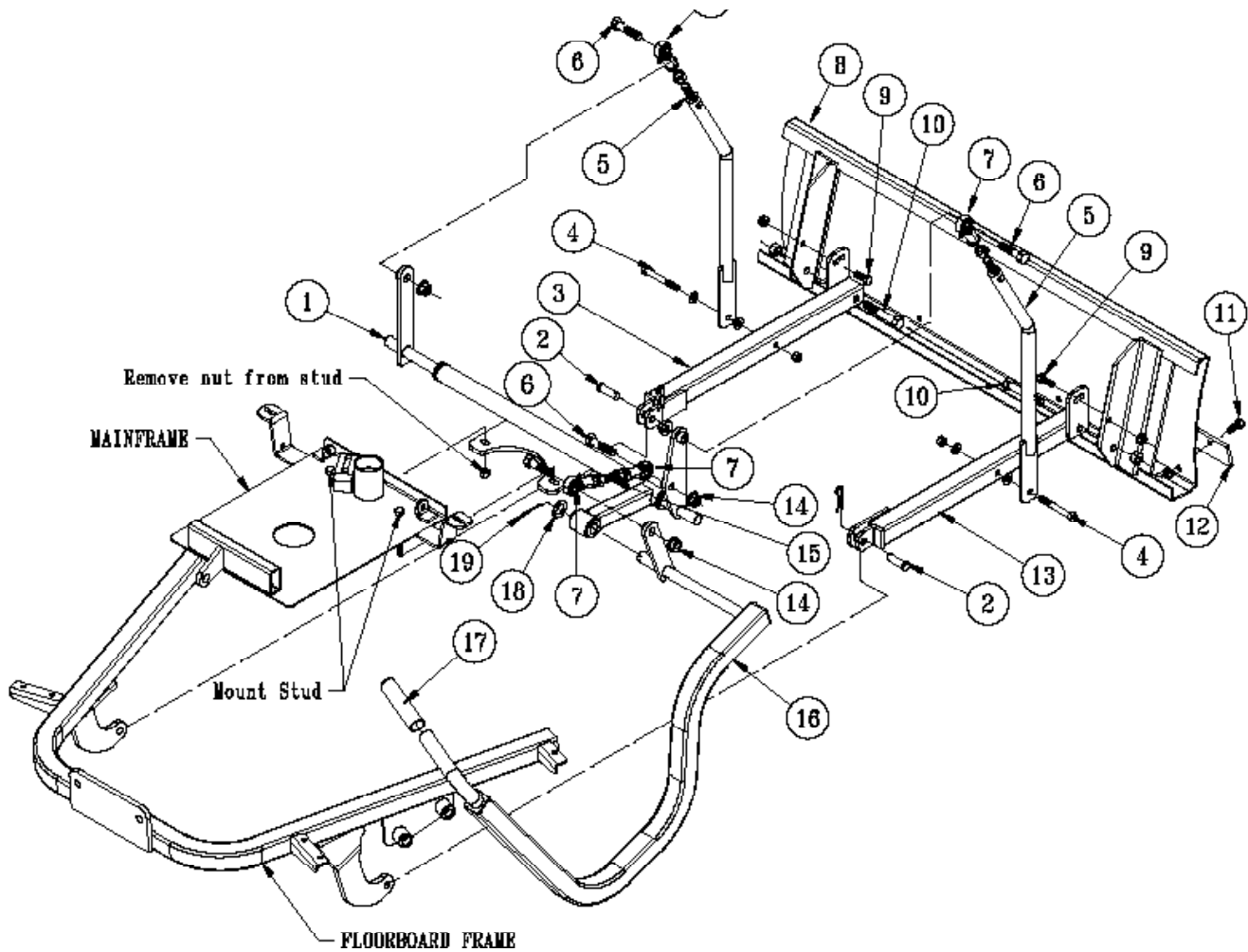

45-009 ALUMINUM 40" SAND PLOW PARTS LIST

REF#	PART#	DESCRIPTION	QUANTITY
1	45-419	Lift Assembly	1
	18-221	Flange Bushing	2
2	HCP-12-150	Clevis Pin, 1/2 x 11/2	2
	HHP-18	Bridge Pin, 1/8	2
3	45-101	Left Pusher Bar	1
4	HB-38-16-250	Hex Bolt, 3/8 - 16 x 2 1/2	2
	HW-38	Flat Washer, 3/8	4
	HNTL-38-16	Nylon Lock Nut, 3/8 - 16	2
5	27-073	Lift Rod	2
6	HB-12-13-200	Hex Bolt, 1/2 - 13 x 2	2
	HMB-12-14	Machine Bushing, 1/2 x 14GA	8
	HNTL-12-13	Nylon Lock Nut, 1/2 - 13	2
7	80-006	Rod End	4
	HNJ-12-20	Jam Nut, 1/2 - 20	4
8	45-092	Aluminum Sand Plow Blade	1
9	HB-38-16-125	Hex Bolt, 3/8 - 16 x 1 1/4	2
	HW-38	Flat Washer, 3/8	2
	HWL-38	Lock Washer, 3/8	2
	HN-38-16	Hex Nut, 3/8 - 16	2
10	HB-12-13-300	Hex Bolt, 1/2 - 13 x 3	2
	HNTL-12-13	Nylon Lock Nut, 1/2 - 13	2
11	HB-38-16-100	Hex Bolt 3/8 - 16 x 1	4
	HNFL-38-16	Flange Whiz-loc Nut, 3/8 - 16	4
12	13-167	Wear Blade	1
13	45-100	Right Pusher Bar	1
14	HB-12-13-200	Hex Bolt, 1/2 - 13 x 2	2
	HMB-12-14	Machine Bushing, 1/2 x 14GA	2
	HNTL-12-13	Nylon Lock Nut, 1/2 - 13	2
15	42-348	Rod	1
16	45-418	Plow Handle	1
17	15-019	Grip	1
18	HMB-34-14	Machine Bushing, 3/4 - 14GA	1
19	HP-18-150	Cotter Pin, 1/8 x 1 1/2	1

SAND PLOW INSTALLATION

- Assemble (Ref# 3 and 13) Pusher Bars to (Ref# 8) Plow using (Ref# 9 and 10) hardware. There are 2 holes to Hex Bolt (Ref# 9) hardware in. Using hole closest to the blade will result in a shallow cut, whereas using the hole furthest from the blade will result in a deeper cut. The slot on the pusher bar is for a more fine tuned adjustment.
- Attach the (Ref# 1) lift assembly to the main frame. There are two studs on the front frame below the front nose console. Remove the nuts on those studs (the studs also hold the floorboard braces). Place the lift assembly on studs next to the floorboard brackets and replace nuts. Tighten nuts down.
- Attach the (Ref# 6) Lift Handle to the lift assembly using (Ref# 18 & 19) Cotter Pin and Machine Bushing. Using (Ref# 15 & 7) Rod and Yoke attach the handle to the lift assembly.
- Put (Ref# 7) Rod Ends onto (Ref# 10) Lift Rods with Jam Nut first. Adjust to equal lengths. Hex Bolt Lift Rods to Lift Arms with Ball Joints to the outside. Hex Bolt from outside with the 1/2" Machine Bushing between Rod End and Lift Arm and the 1/2 - 13 nut on the inside. Use (Ref# 6) Hardware.
- Slide Plow under machine and connect to machine. Use (Ref# 2) Clevis Pin and Bridge Pin.
- Lift up the plow using the bottom hole in the Lift Rod as a starting point. Secure to the Pusher Bars. Use (Ref# 4) hardware. For maximum blade clearance use the second hole from the front of the pusher bar. The three holes in the lift rods are for adjusting the hand lever. The top hole moves the lever forward. Each hole down moves the lever to the rear of the machine.
- For fine tuning of blade height off ground twist (Ref# 7) rod end on (Ref# 15) rod. Twisting the rod end out will increase down pressure. Twisting the rod end onto the rod will decrease down pressure.

45-019 ALUMINUM 60" SAND PLOW DRAWING

Front Attachment

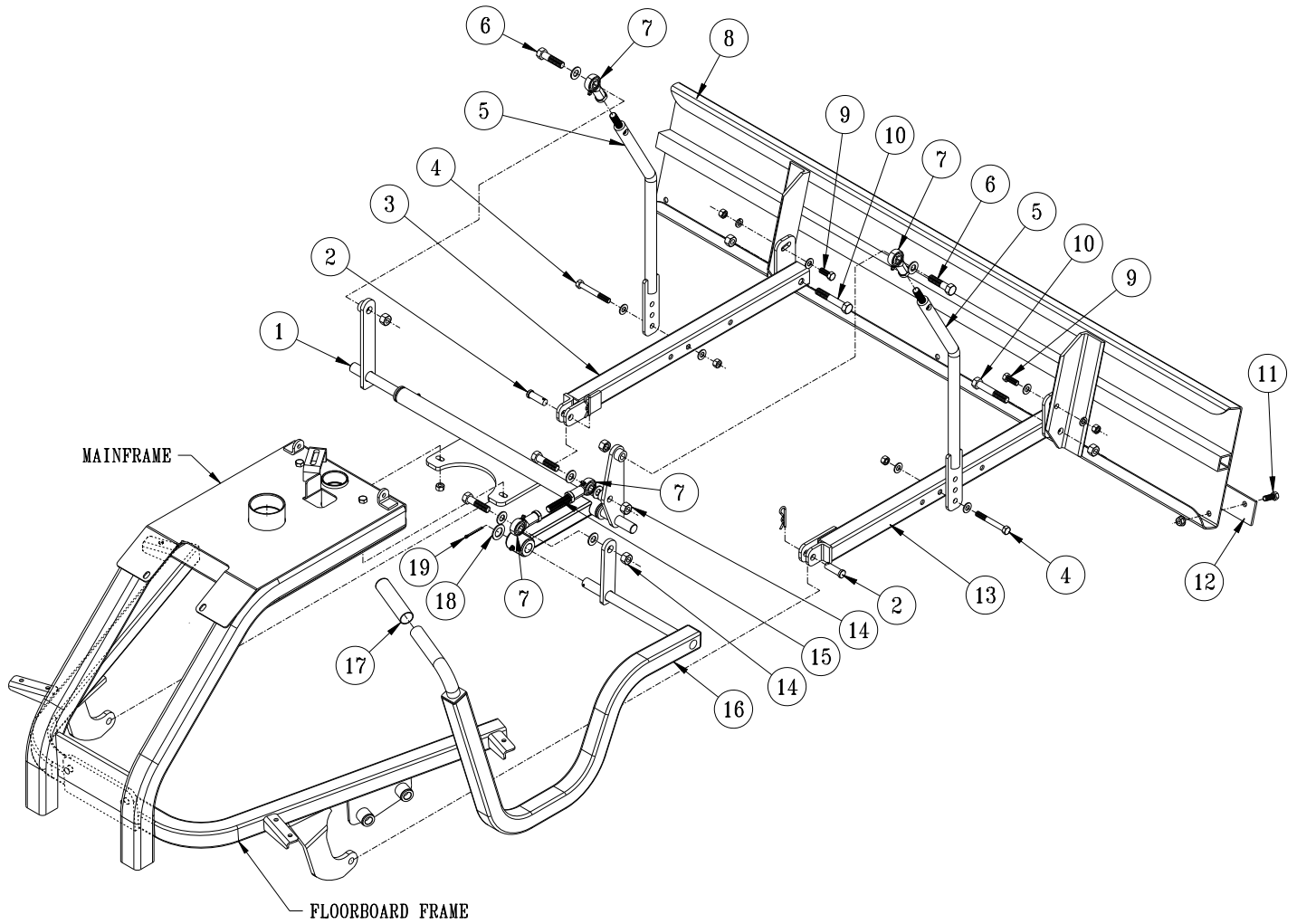

45-019 ALUMINUM 60" SAND PLOW PARTS LIST

REF#	PART#	DESCRIPTION	QUANTITY
1	45-419	Lift Assembly	1
2	HCP-12-150	Clevis Pin, 1/2 x 1 1/2	2
	HHP-18	Bridge Pin, 1/8	2
3	45-101	Left Pusher Bar	1
4	HB-38-16-250	Hex Bolt, 3/8 - 16 x 2 1/2	2
	HW-38	Flat Washer, 3/8	4
	HNTL-38-16	Nylon Lock Nut, 3/8 - 16	2
5	27-073	Lift Rod	2
6	HB-12-13-200	Hex Bolt, 1/2 - 13 x 2	2
	HMB-12-14	Machine Bushing, 1/2 x 14GA	8
	HNTL-12-13	Nylon Lock Nut, 1/2 - 13	2
7	80-006	Rod End	4
	HNJ-12-20	Jam Nut, 1/2 - 20	4
8	45-159	Aluminum Sand Plow Blade	1
9	HB-38-16-125	Hex Bolt, 3/8 - 16 x 1 1/4	2
	HW-38	Flat Washer, 3/8	2
	HWL-38	Lock Washer, 3/8	2
	HN-38-16	Hex Nut, 3/8 - 16	2
10	HB-12-13-300	Hex Bolt, 1/2 - 13 x 3	2
	HNTL-12-13	Nylon Lock Nut, 1/2 - 13	2
11	HB-38-16-100	Hex Bolt, 3/8 - 16 x 1	4
	HNFL-38-16	Flange Whiz-loc Nut, 3/8 - 16	4
12	35-012	Wear Blade	1
13	45-100	Right Pusher Bar	1
14	HB-12-13-200	Hex Bolt, 1/2 - 13 x 2	2
	HMB-12-14	Machine Bushing 1/2 x 14GA	2
	HNTL-12-13	Nylon Lock Nut 1/2 - 13	2
15	42-348	Rod	1
16	45-418	Plow Handle	1
17	15-019	Grip	1
18	HMB-34-14	Machine Bushing 3/4 - 14GA	1
19	HP-18-150	Cotter Pin 1/8 x 1 1/2	1

SAND PLOW INSTALLATION

- Assemble (Ref# 3 and 13) Pusher Bars to (Ref# 8) Plow using (Ref# 9 and 10) hardware. There are 2 holes to Hex Bolt (Ref# 9) hardware in. Using hole closest to the blade will result in a shallow cut, whereas using the hole furthest from the blade will result in a deeper cut. The slot on the pusher bar is for a more fine tuned adjustment.
- Attach the (Ref# 1) lift assembly to the main frame. There are two studs on the front frame below the front nose console. Remove the nuts on those studs (the studs also hold the floorboard braces). Place the lift assembly on studs next to the floorboard brackets and replace nuts. Tighten nuts down.
- Attach the (Ref# 6) Lift Handle to the lift assembly using (Ref# 18 & 19) Cotter Pin and Machine Bushing. Using (Ref# 15 & 7) Rod and Yoke attach the handle to the lift assembly.
- Put (Ref# 7) Rod Ends onto (Ref# 10) Lift Rods with Jam Nut first. Adjust to equal lengths. Hex Bolt Lift Rods to Lift Arms with Ball Joints to the outside. Hex Bolt from outside with the 1/2" Machine Bushing between Rod End and Lift Arm and the 1/2 - 13 nut on the inside. Use (Ref# 6) Hardware.
- Slide Plow under machine and connect to machine. Use (Ref# 2) Clevis Pin and Bridge Pin.
- Lift up the plow using the bottom hole in the Lift Rod as a starting point. Secure to the Pusher Bars. Use (Ref# 4) hardware. For maximum blade clearance use the second hole from the front of the pusher bar. The three holes in the lift rods are for adjusting the hand lever. The top hole moves the lever forward. Each hole down moves the lever to the rear of the machine.
- For fine tuning of blade height off ground twist (Ref# 7) rod end on (Ref# 15) rod. Twisting the rod end out will increase down pressure. Twisting the rod end onto the rod will decrease down pressure.

45-179 40" ANGLE PLOW

Front Attachment

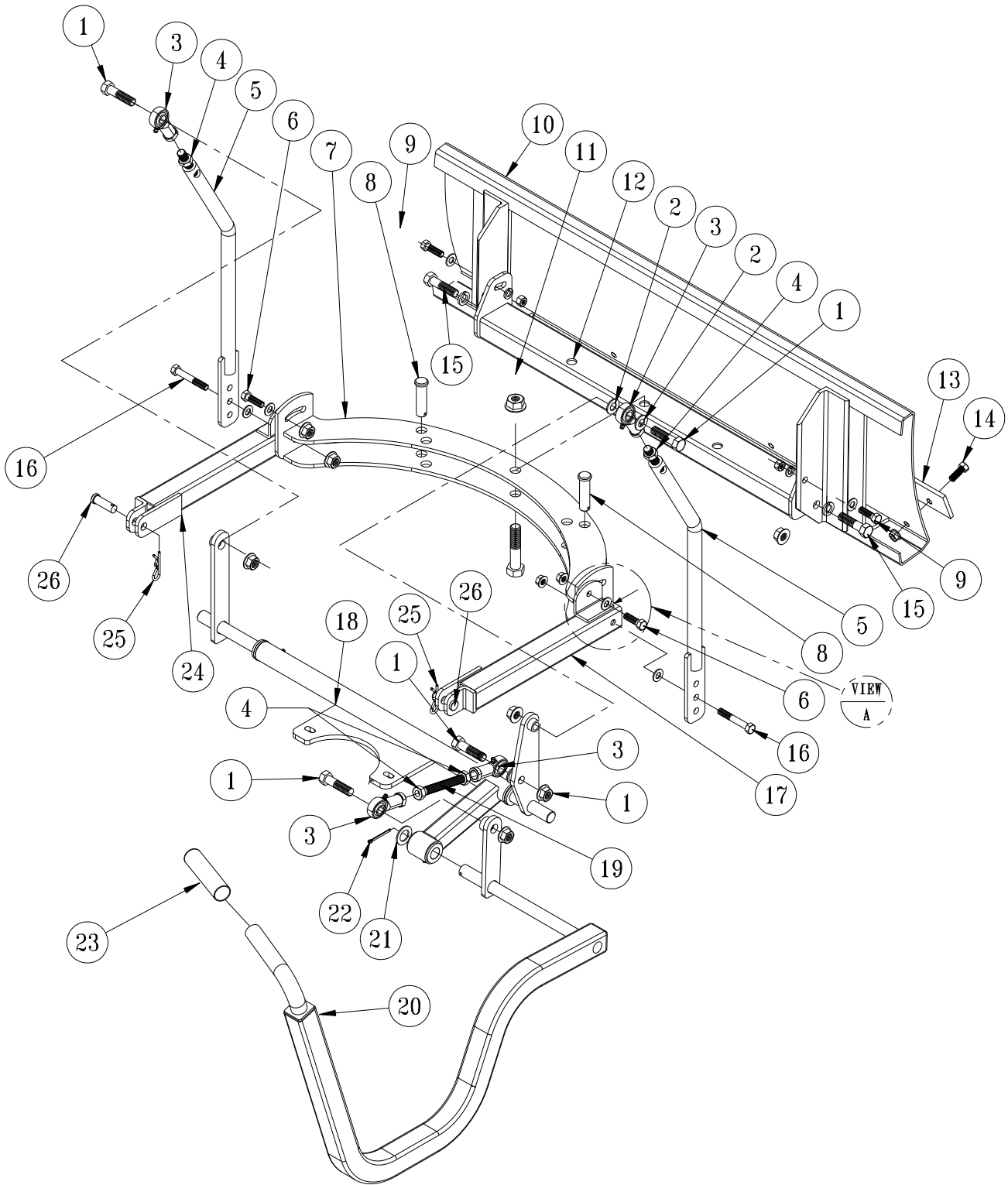

40" ANGLE PLOW PARTS LIST

REF#	PART#	DESCRIPTION	QUANTITY
1	HB-12-13-200	Hex Bolt, 1/2 - 13 x 2	4
	HNTL-12-13	Nylon Lock Nut, 1/2 - 13	4
2	HMB-12-14	Machine Bushing, 1/2 x 14GA	8
3	80-006	Rod End	4
4	HNJ-12-20	Jam Nut, 1/2 - 20	4
5	27-073	Lift Rod	2
6	HB-38-16-125	Hex Bolt, 5/8 - 16 x 1 1/4	2
	HNFL-38-16	Flange Whiz-Loc Nut, 5/8 - 16	2
7	45-181	Plow Mount	1
8	HCP-58-250	Clevis Pin, 5/8 x 2 1/2	2
	HHP-18	Bridge Pin, 1/8	2
9	HB-38-16-125	Hex Bolt, 3/8 - 16 x 1 1/4	2
	HW-38	Flat Washer, 3/8	2
	HWL-38	Lock Washer, 3/8	2
	HN-38-16	Hex Nut, 3/8 - 16	2
10	27-017	Aluminum Sand Plow Blade	1
11	HB-58-11-300	Hex Bolt, 5/8 - 11 x 3	1
	HNTL-58-11	Nylon Lock Nut, 5/8 - 11	1
12	42-495	Pivot Frame	1
13	13-167	Wear Blade	1
14	HB-38-16-100	Hex Bolt, 3/8 - 16 x 1	4
	HNFL-38-16	Flange Whiz-Loc Nut, 3/8 - 16	4
15	HB-12-13-200	Hex Bolt, 1/2 - 13 x 2	2
	HWL-12	Lock Washer, 1/2	2
16	HB-38-16-250	Hex Bolt, 3/8 - 16 x 2 1/2	2
	HW-38	Flat Washer, 3/8	2
	HNTL-38-16	Nylon Lock Nut, 3/8 - 16	4
17	45-231	Right Pusher Bar	1
18	45-419	Lift Assembly	1
	18-221	Flange Bushing	2
19	42-348	Rod	1
20	45-418	Lift Handle	1
21	HMB-34-14	Machine Bushing, 3/4 - 14GA	1
22	HP-18-150	Cotter Pin, 1/8 x 1 1/2	1
23	15-019	Grip	1
24	45-232	Left Pusher Bar	1
25	HHP-18	Bridge Pin, 1/8	2
26	HCP-12-150	Clevis Pin, 1/2 x 1 1/2	2

45-180 60" ANGLE PLOW

Front Attachment

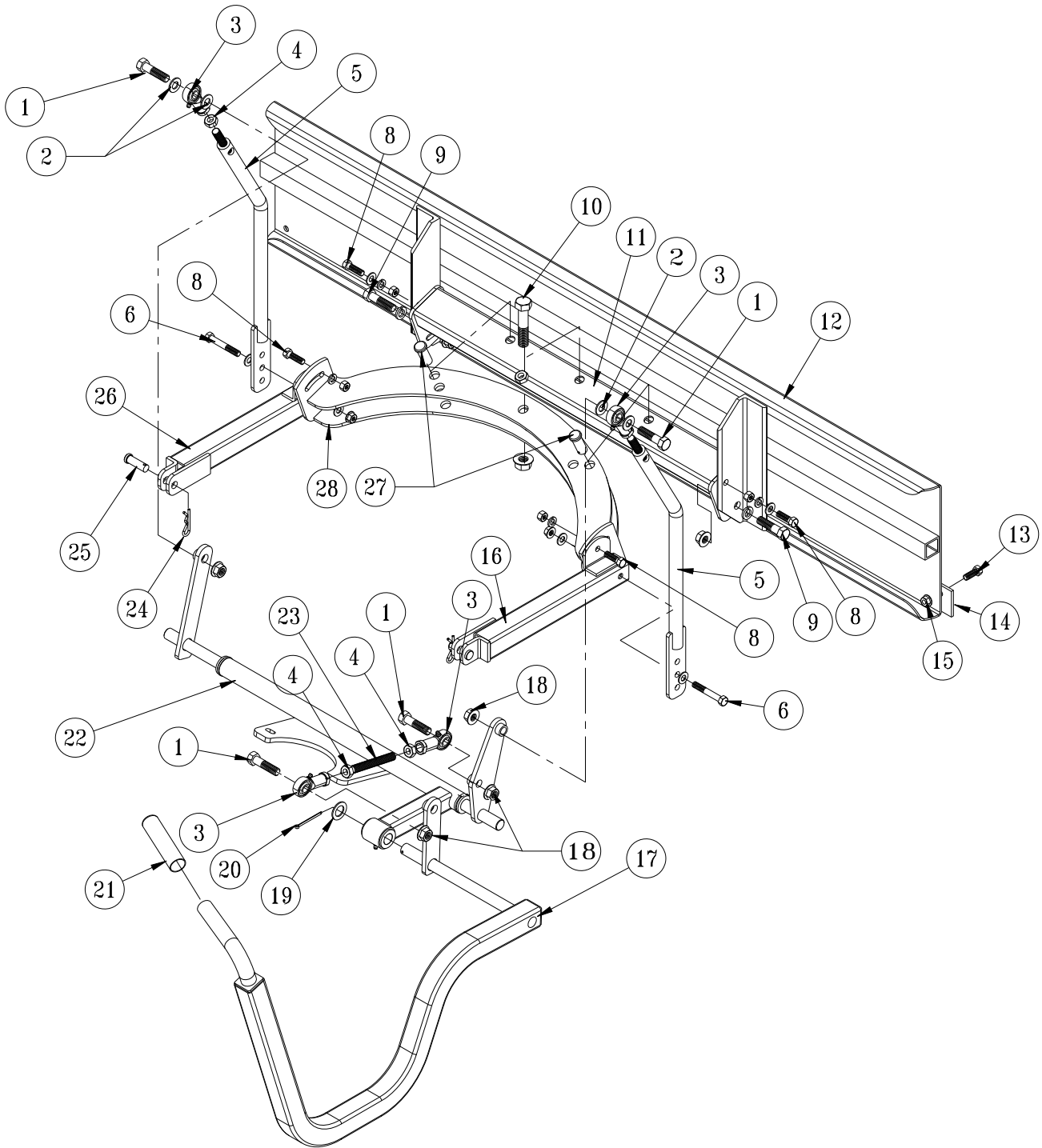

60" ANGLE PLOW PARTS LIST

REF#	PART#	DESCRIPTION	QUANTITY
1	HB-12-13-200	Hex Bolt, 1/2 - 13 x 2	4
2	HMB-12-14	Machine Bushing, 1/2 x 14GA	8
3	80-006	Rod End	4
4	HNJ-12-20	Jam Nut, 1/2 - 20	4
5	27-073	Lift Rod	2
6	HB-38-16-250	Hex Bolt, 3/8 - 16 x 2 1/2	2
	HW-38	Flat Washer, 3/8	4
	HNTL-38-16	Nylon Lock Nut, 3/8 - 16	2
7	HB-38-16-250	Hex Bolt, 3/8 - 16 x 2 1/2	2
	HNTL-38-16	Nylon Lock Nut, 3/8 - 16	2
8	HB-38-16-125	Hex Bolt, 3/8 - 16 x 1 1/4	4
	HW-38	Flat Washer, 3/8	4
	HWL-38	Lock Washer, 3/8	4
	HN-38-16	Hex Nut, 3/8 - 16	4
9	HB-12-13-200	Hex Bolt, 1/2 - 13 x 2	2
	HNTL-12-13	Nylon Lock Nut, 1/2 - 13	2
10	HB-58-11-300	Hex Bolt, 5/8 - 11 x 3	1
	HNTL-58-11	Nylon Lock Nut, 5/8 - 11	1
11	42-495	Pivot Frame	1
12	45-159	Aluminum 60" Sand Plow Blade	1
13	HB-38-16-100	Hex Bolt, 3/8 - 16 x 1	4
14	35-012	Wear Blade	1
15	HNFL-38-16	Flange Whiz-loc Nut, 3/8 - 16	4
16	45-182	Right Pusher Bar	1
17	45-418	Lift Handle	1
18	HNTL-12-13	Nylon Lock Nut, 1/2 - 13	4
19	HMB-34-14	Machine Bushing, 3/4 - 14GA	1
20	HP-18-150	Cotter Pin, 1/8 x 1 1/2	1
21	15-019	Grip	1
22	45-419	Lift Assembly	1
	18-221	Flange Bushing	2
23	42-348	Rod	1
24	HHP-18	Bridge Pin, 1/8	2
25	HCP-12-150	Clevis Pin, 1/2 x 1 1/2	2
26	45-183	Left Pusher Bar	1
27	HCP-58-250	Clevis Pin, 5/8 x 2 1/2	2
	HHP-18	Bridge Pin, 1/8	2
28	45-181	Plow Mount	1

45-014 WEED CULTIVATOR

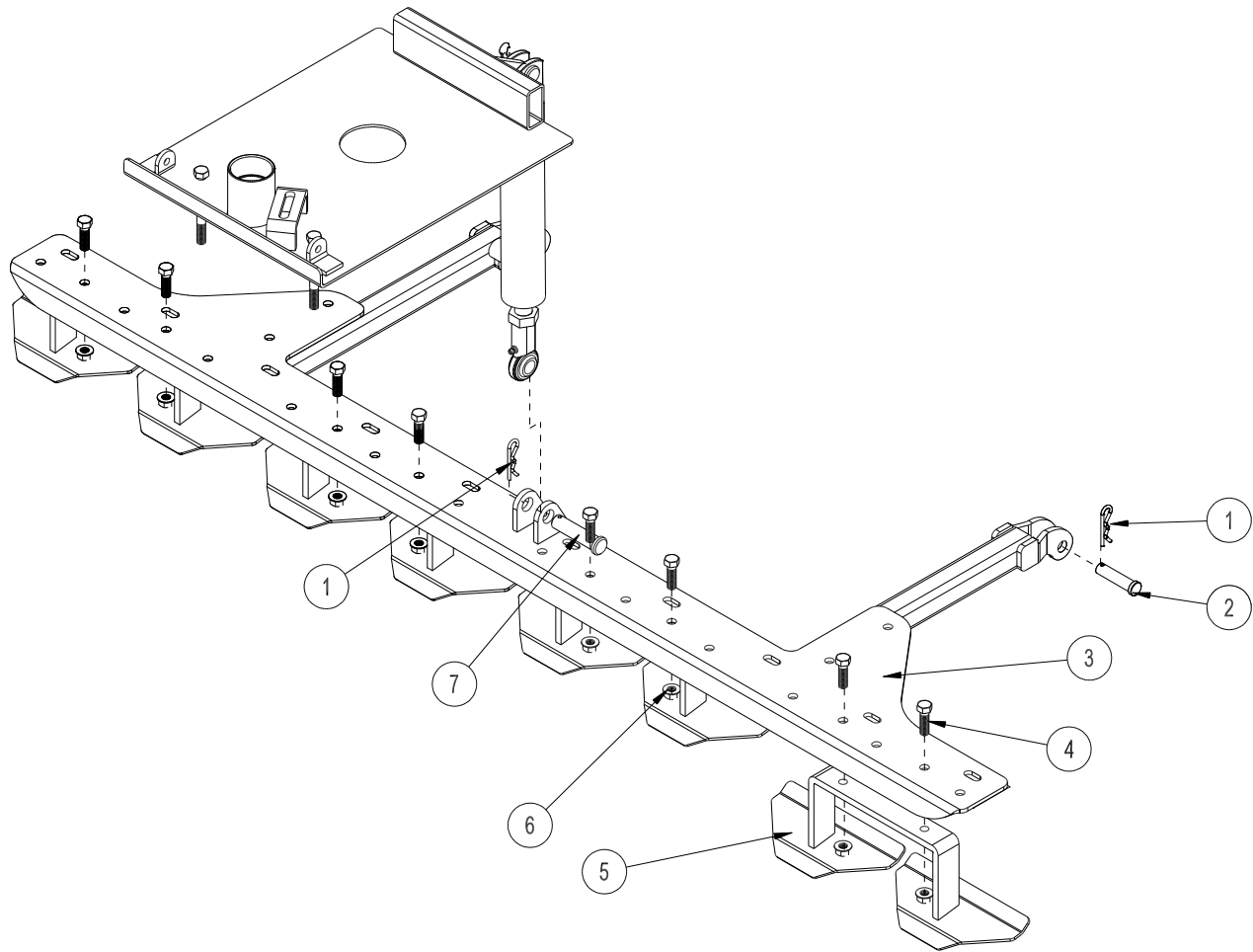

Center Attachment

REF#	PART #	DESCRIPTION	QUANTITY
1	HHP-18	Bridge Pin, $\frac{1}{8}$	3
2	HCP-12-200	Clevis Pin, $\frac{1}{2} \times 2$	2
3	45-185	Center Bar Lift	1
4	HB-38-16-125	Hex Bolt, $\frac{3}{8} - 16 \times 1\frac{1}{4}$	8
5	13-096	Blade Assembly	4
6	HNFL-38-16	Flange Nut, $\frac{3}{8} - 16$	8
7	HCP-58-250	Clevis Pin, $\frac{5}{8} \times 2\frac{1}{2}$	1

INSTALLATION INSTRUCTIONS

1. Blade assemblies (Ref 5) should be Hex Bolted to the center lift bar (Ref 3). Use the $\frac{3}{8} - 16 \times 1\frac{1}{4}$ Hex Bolt (Ref 4) and Flange Whiz-loc Nut (Ref 6).
2. Attach the center lift bar to main frame using (Ref 1 and 2) clevis pin and bridge pin.
3. Lift center lift bar up or extend cylinder so rod end lines up with the holes on the center of the attachment lift. Use clevis pin and bridge pin (Ref 7 and 1) to fasten cylinder to sand cultivator.
4. Turn machine on and test for proper operation.

45-006 SAND CULTIVATOR DRAWING

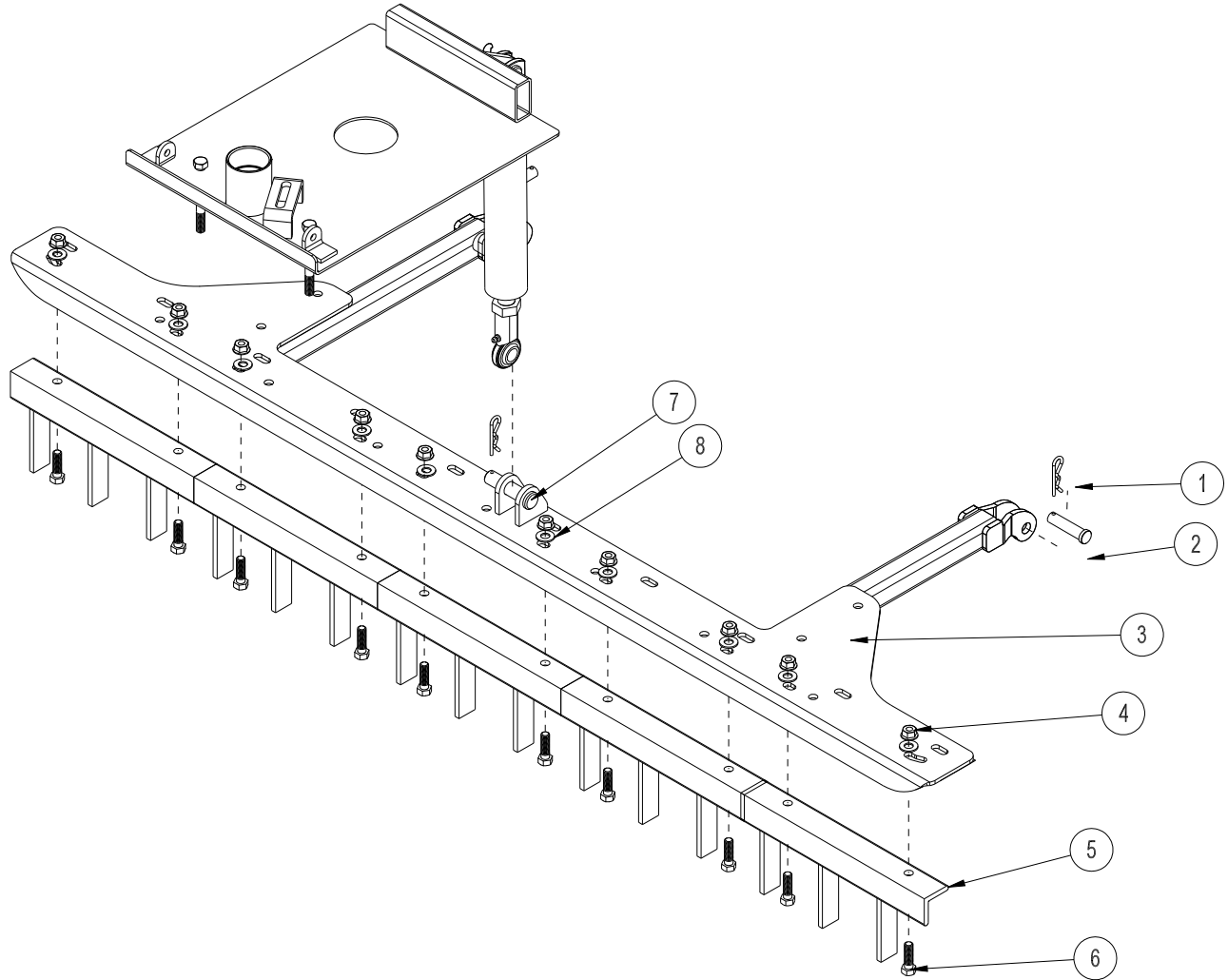

Center Attachment

REF#	PART#	DESCRIPTION	QTY
1	HHP-18	Bridge Pin, 1/8	3
2	HCP-12-200	Clevis Pin, 1/2 x 2	2
3	45-184	Center Lift Bar	1
4	HNTL-38-16	Nylon Lock Nut, 3/8 - 16	10
5	42-038	Tine Segment	5
6	HB-38-16-100	Hex Bolt, 3/8 - 16 x 1	10
7	HCP-58-250	Clevis Pin, 5/8 x 2 1/2	1

INSTALLATION INSTRUCTIONS

1. Tine segments (Ref 5) should be Hex Bolted to the center lift bar (Ref 3). Use the 3/8 - 16 x 1 Hex Bolt (Ref 6) and Nylon Lock Nut (Ref 4).
2. Attach the center lift bar to main frame using (Ref 1 and 2) clevis pin and bridge pin.
3. Lift center lift bar up or extend cylinder so rod end lines up with the holes on the center of the attachment lift. Use clevis pin and bridge pin (Ref 7 and 1) to fasten cylinder to sand cultivator.
4. Turn machine on and test for proper operation.

45-008 SAND CULTIVATOR WITH SPRING TINES DRAWING

Center Attachment

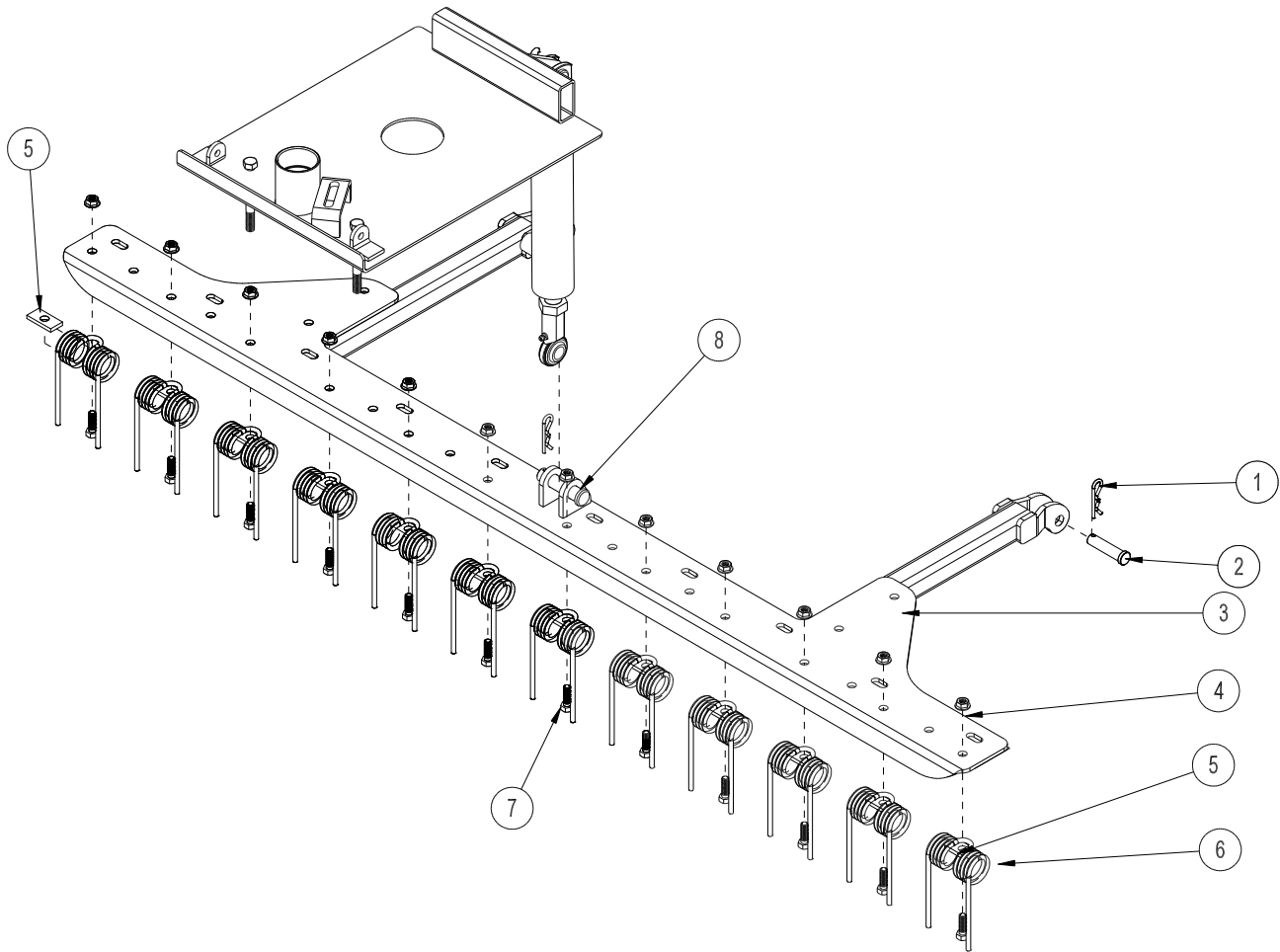

REF#	PART#	DESCRIPTION	QUANTITY
1	HHP-18	Bridge Pin, $\frac{1}{8}$	3
2	HCP-12-200	Clevis Pin, $\frac{1}{2} \times 2$	2
3	45-185	Center Lift Bar	1
4	HNFL-516-18	Flange Whiz-loc Nut, $\frac{5}{16} - 18$	12
5	42-177	Spring Holder	12
6	42-122	Rake Spring	12
7	HB-516-18-150	Hex Bolt, $\frac{5}{16} - 18 \times 1\frac{1}{2}$	12
8	HCP-58-250	Clevis Pin, $\frac{5}{8} \times 2\frac{1}{2}$	1

INSTALLATION INSTRUCTIONS

1. Springs (Ref 6) should be Hex Bolted to the center lift bar (Ref 3) with the spring holder (Ref 5) between center lift bar and the spring. Hex Bolt in place with $\frac{5}{16} - 18$ Hex Bolt (Ref 7) and Whiz-loc Nut (Ref 4).
2. Attach the center lift bar to main frame using (Ref 1 and 2) clevis pin and bridge pin.
3. Lift center lift bar up or extend cylinder so rod end lines up with the holes on the center of the attachment lift. Use clevis pin and bridge pin (Ref 8 and 1) to fasten cylinder to sand cultivator.
4. Turn machine on and test for proper operation.

45-012 CONSTRUCTION LEVELING BLADE DRAWING

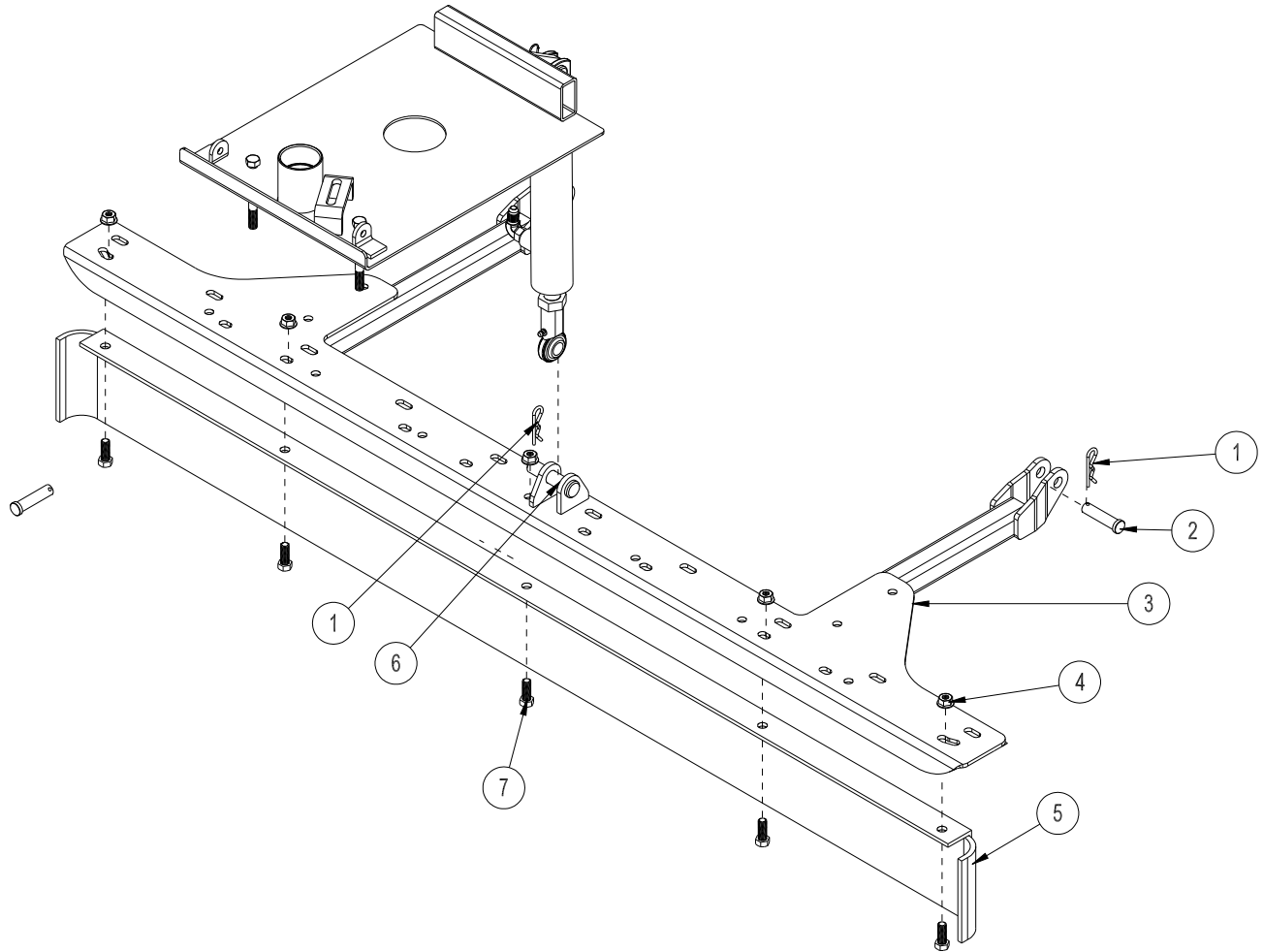

Center Attachment

REF#	PART#	DESCRIPTION	QUANTITY
1	HHP-18	Bridge Pin, $\frac{1}{8}$	3
2	HCP-12-200	Clevis Pin, $\frac{1}{2} \times 2$	2
3	45-116	Center Lift Bar	1
4	HNTL-38-16	Nylon Lock Nut, $\frac{3}{8}$ - 16	5
5	42-097	Leveling Blade	1
6	HCP-58-250	Clevis Pin, $\frac{5}{8} \times 2\frac{1}{2}$	1
7	HB-38-16-100	Hex Bolt, $\frac{3}{8}$ - 16 x 1	5

INSTALLATION INSTRUCTIONS

- Hex Bolt leveling blade (Ref 5) to center lift bar (Ref 3) using five $\frac{3}{8}$ - 16 x 1 Hex Bolts (Ref 7) and five $\frac{3}{8}$ - 16 Nylon Lock Nuts (Ref 4) as shown on drawing.
- Attach the center lift bar to main frame using clevis pin and bridge pin (Ref 1 and 2).
- Lift center lift bar up or extend cylinder so rod end lines up with the holes on the center of the center lift bar. Use $\frac{5}{8} \times 2\frac{1}{2}$ clevis pin and bridge pin (Ref 6 & 1) to fasten cylinder to cultivator.
- Turn machine on and test for proper operation.

45-013 FIELD SCARIFIER WITH TINES DRAWING

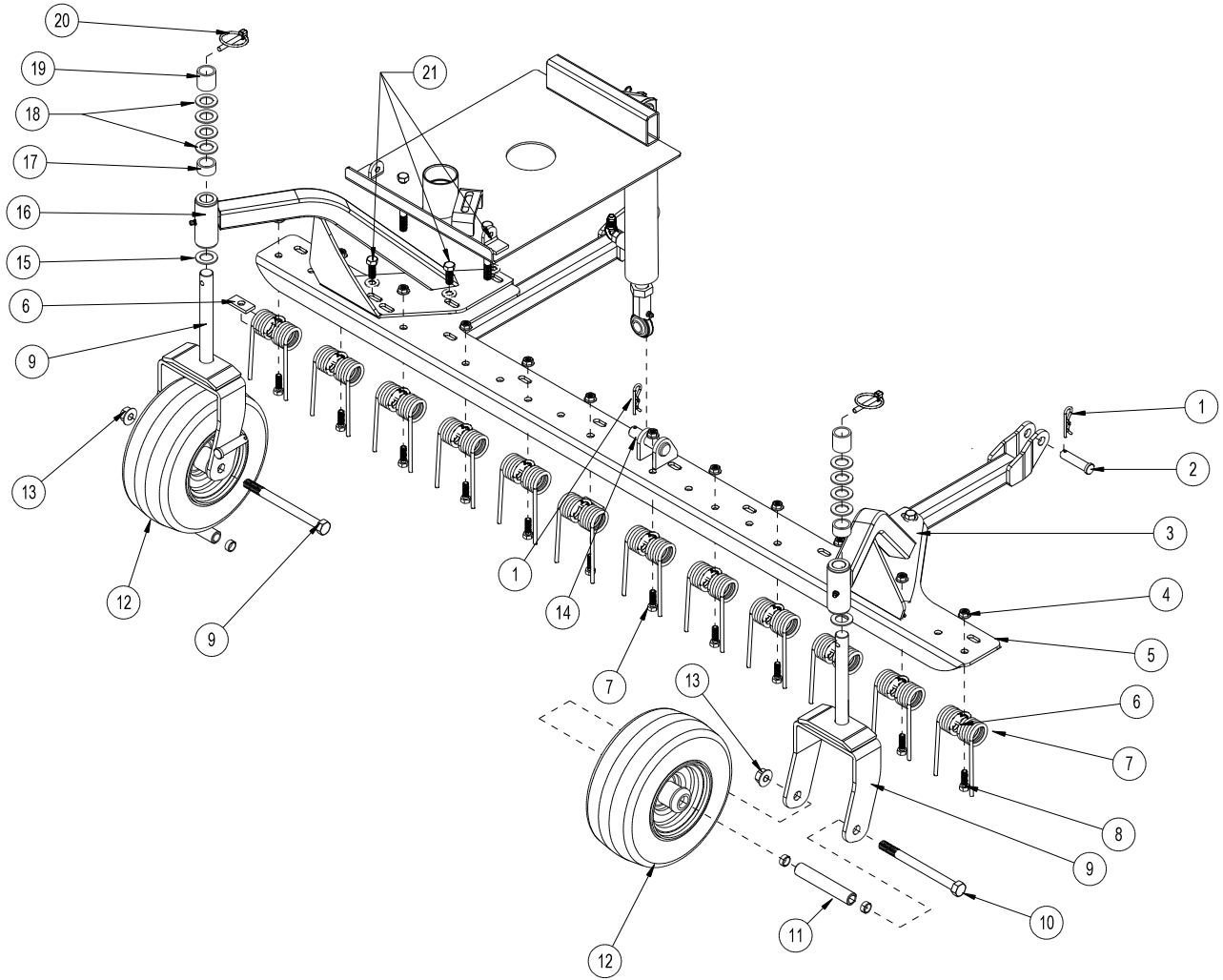

Center Attachment

45-013 FIELD SCARIFIER WITH TINES PARTS LIST

REF#	PART#	DESCRIPTION	QUANTITY
1	HHP-18	Bridge Pin $\frac{1}{8}$	3
2	HCP-12-200	Clevis Pin $\frac{1}{2} \times 2$	2
3	42-205	Left Caster Wheel Bracket	1
	10-025	Flange Bushing (Part of 42-288)	2
	HG-14-28-180	Grease Fitting $\frac{1}{4} - 28 \times 180^\circ$ (Part of 42-288)	1
4	HNFL-516-18	Flange Whiz-Lock Nut $\frac{5}{16} - 18$	12
5	45-137	Center Lift Bar	1
6	42-177	Spring Holder	12
7	42-122	Rake Spring	12
8	HB-516-18-150	Hex Bolt $\frac{5}{16} - 18 \times 1\frac{1}{2}$	12
9	42-204	Caster Fork	2
10	HB-12-13-600	Hex Bolt $\frac{1}{2} - 13 \times 6$	2
11	33-338	Axle Bearing	2
12	42-202	Tire & Wheel	2
13	HNTL-12-13	Lock Nut $\frac{1}{2} - 13$	2
14	HCP-58-250	Clevis Pin $\frac{5}{8} \times 2\frac{1}{2}$	1
15	HMB-34-14	Machine Bushing $\frac{3}{4} \times 14GA$	2
16	42-206	Right Caster Wheel Bracket	1
	10-025	Flange Bushing (Part of 42-289)	2
	HG-14-28-180	Grease Fitting $\frac{1}{4} - 28 \times 180^\circ$ (Part of 42-289)	1
17	42-215	Short Spacer	2
18	HMB-34-10	Machine Bushing $\frac{3}{4} \times 10GA$	8
19	42-214	Long Spacer	2
20	42-539	Lynch Pin $\frac{1}{4}$ "	2
21	HB-38-16-100	Hex Bolt $\frac{3}{8} - 16 \times 1$	6
	HW-38	Washer $\frac{3}{8}$	6
	HNTL-38-16	Lock Nut $\frac{3}{8} - 16$	6

INSTRUCTIONS

This accessory comes with only the caster forks assembled.

1. Bolt the springs (Ref 7) to the center lift bar (Ref 5) with the spring holder (Ref 6) between center lift bar and the spring. Bolt in place with $\frac{5}{16} - 18 \times 1\frac{1}{2}$ bolt (Ref 8) and Whiz-lock nut (Ref 4).
2. Mount the right and left caster wheel brackets (Ref 3 and 16) to the center lift bar (Ref 5) using the rest of $\frac{3}{8} - 16 \times 1$ bolts, washers and nuts (Ref 21).
3. Install assembled caster wheel forks (Ref 9-13) onto the right and left caster wheel brackets (Ref 3 and 16).
4. Use the machine bushings and spacers (Ref 15, 17-19) as shown to secure the caster forks to the caster wheel brackets. Use the lynch pin (Ref 20) to hold in place.
5. Attach the center lift bar to main frame using (Ref 1 and 2) clevis pin and bridge pin.
6. Lift center lift bar up or extend cylinder so rod end lines up with the holes on the center of the attachment lift. Use clevis pin and bridge pin (Ref 14 and 1) to fasten cylinder to sand cultivator.
7. Adjust caster wheels (Ref 12) by placing the short (Ref 16) or long spacer (Ref 18) on the caster wheel fork before placing the caster wheel assembly into the caster wheel brackets. Be sure both caster wheels are adjusted to the same height.
8. Turn machine on and test for proper operation.

45-007 INFIELD SCARIFIER WITH VERTICAL BLADES DRAWING

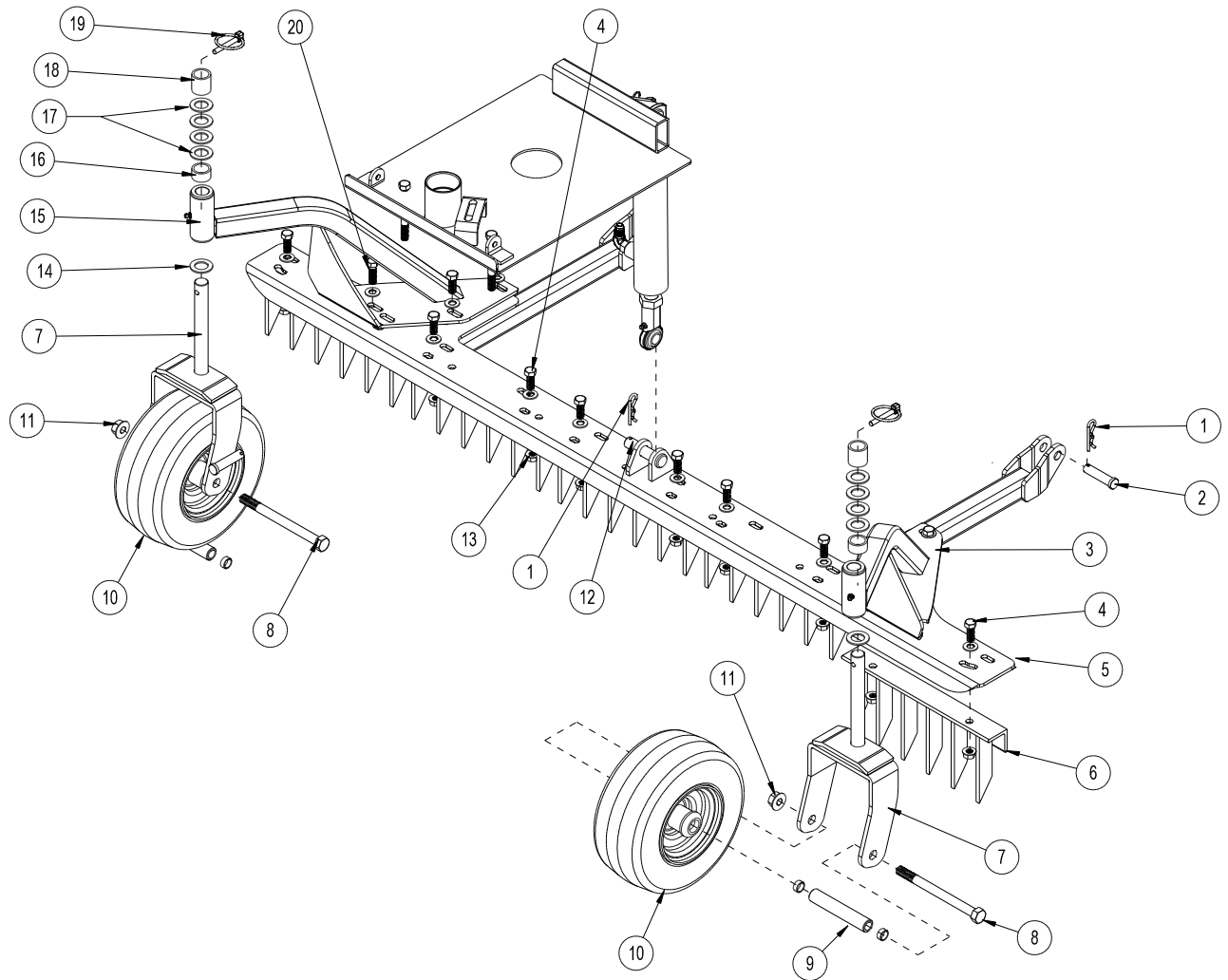

Center Attachment

45-007 INFIELD SCARIFIER WITH VERTICAL BLADES PARTS LIST

REF#	PART#	DESCRIPTION	QUANTITY
1	HHP-18	Bridge Pin, $\frac{1}{8}$	3
2	HCP-12-200	Clevis Pin, $\frac{1}{2} \times 2$	2
3	42-205	Left Castor Wheel Bracket	1
	10-025	Flange Bushing (Part of 42-205)	2
	HG-14-28-180	Grease Fitting, $\frac{1}{4} - 28 \times 180^\circ$ (Part of 42-205)	1
4	HB-38-16-100	Hex Bolt, $\frac{3}{8} - 16 \times 1$	12
	HW-38	Flat Washer, $\frac{3}{8}$	12
5	45-116	Center Lift Bar	1
6	26-042	Tine Segment	5
7	42-204	Castor Fork	2
8	HB-12-13-600	Hex Bolt, $\frac{1}{2} - 13 \times 6$	2
9	33-338	Axle Bearing	2
10	42-202	Tire and Wheel	2
11	HNTL-12-13	Nylon Lock Nut, $\frac{1}{2} - 13$	2
12	HCP-58-250	Clevis Pin, $\frac{5}{8} \times 2\frac{1}{2}$	1
13	HNTL-38-16	Nylon Lock Nut, $\frac{3}{8} - 16$	14
14	HMB-34-14	Machine Bushing, $\frac{3}{4} \times 14GA$	2
15	42-206	Right Castor Wheel Bracket	1
	10-025	Flange Bushing (Part of 42-206)	2
	HG-14-28-180	Grease Fitting, $\frac{1}{4} - 28 \times 180^\circ$ (Part of 42-206)	1
16	42-215	Short Spacer	2
17	HMB-34-10	Machine Bushing, $\frac{3}{4} \times 10GA$	8
18	42-214	Long Spacer	2
19	42-539	Lynch Pin, $\frac{5}{16}$	2
20	HB-38-16-125	Hex Bolt, $\frac{3}{8} - 16 \times 1\frac{1}{4}$	2
	HW-38	Flat Washer, $\frac{3}{8}$	2

INSTALLATION INSTRUCTIONS

- Assemble the tine Segments (Ref 6) to the center lift bar (Ref 5) using the $\frac{3}{8} - 16 \times 1$ Hex Bolts, washers and nuts (Ref 4).
- Mount the right and left castor wheel brackets (Ref 3 and 15) to the center lift bar (Ref 5) using the rest of $\frac{3}{8} - 16 \times 1$ Hex Bolts, washers and nuts (Ref 4 & 13). Mount the last two digger blades at this time using the $\frac{3}{8} - 16 \times 1\frac{1}{4}$ Hex Bolts, washers and nuts (Ref 20 & 13).
- Slide the Scarifier under the machine lining up the hydraulic cylinder and the center of the center lift bar.
- Extend hydraulic cylinder all the way down by pushing the lever forward.
- Mount the rod end of the cylinder onto the center lift bar and secure with a clevis pin (Ref 12) and bridge pin (Ref 1).
- Attach the arms on the center lift bar to the main frame on the machine and secure with clevis pin (Ref 2) and bridge pin (Ref 1).
- Turn machine on and test for proper operation.
- Adjust castor wheels (Ref 12) by placing the short (Ref 16) or long spacer (Ref 18) on the castor wheel fork before placing the castor wheel assembly into the castor wheel brackets. Be sure both castor wheels are adjusted to the same height.

45-360 INFIELD SCARIFIER WITH LONG VERTICAL BLADES DRAWING

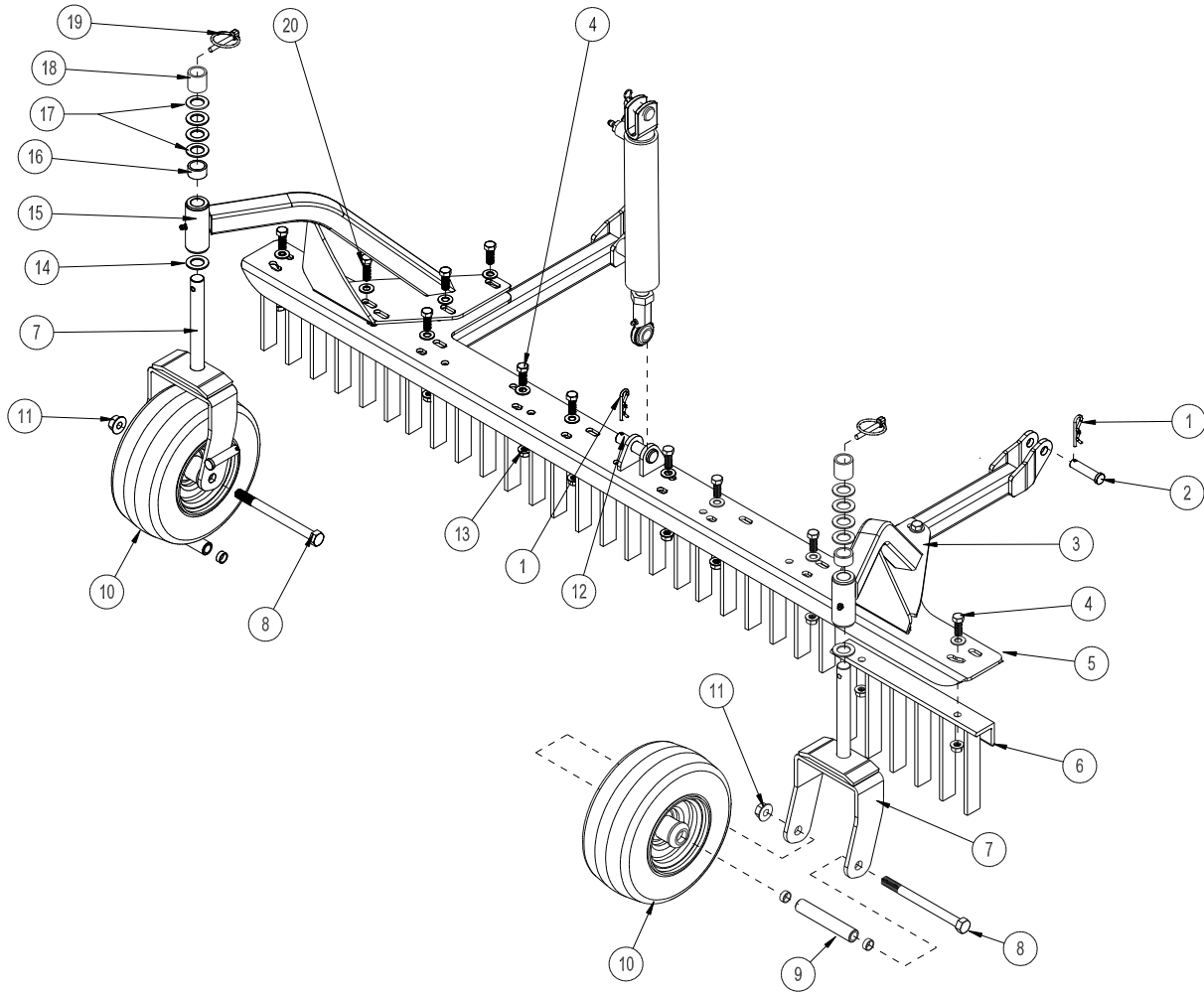

Center Attachment

45-360 INFIELD SCARIFIER WITH LONG VERTICAL BLADES PARTS LIST

REF#	PART#	DESCRIPTION	QUANTITY
1	HHP-18	Bridge Pin, $\frac{1}{8}$	3
2	HCP-12-200	Clevis Pin, $\frac{1}{2} \times 2$	2
3	42-288	Left Castor Wheel Bracket	1
	10-025	Flange Bushing (Part of 42-205)	2
	HG-14-28-180	Grease Fitting, $\frac{1}{4} - 28 \times 180^\circ$ (Part of 42-205)	1
4	HB-38-16-100	Hex Bolt, $\frac{3}{8} - 16 \times 1$	12
	HW-38	Flat Washer, $\frac{3}{8}$	12
5	45-116	Center Lift Bar	1
6	42-241	Tine Segment	5
7	42-204	Castor Fork	2
8	HB-12-13-600	Hex Bolt, $\frac{1}{2} - 13 \times 6$	2
9	33-338	Axle Bearing	2
10	42-202	Tire and Wheel	2
11	HNTL-12-13	Nylon Lock Nut, $\frac{1}{2} - 13$	2
12	HCP-58-250	Clevis Pin, $\frac{5}{8} \times 2\frac{1}{2}$	1
13	HNTL-38-16	Nylon Lock Nut, $\frac{3}{8} - 16$	14
14	HMB-34-14	Machine Bushing, $\frac{3}{4} \times 14GA$	2
15	42-289	Right Castor Wheel Bracket	1
	10-025	Flange Bushing (Part of 42-206)	2
	HG-14-28-180	Grease Fitting, $\frac{1}{4} - 28 \times 180^\circ$ (Part of 42-206)	1
16	42-215	Short Spacer	2
17	HMB-34-10	Machine Bushing, $\frac{3}{4} \times 10GA$	8
18	42-214	Long Spacer	2
19	42-539	Lynch Pin, $\frac{5}{16}$	2
20	HB-38-16-125	Hex Bolt, $\frac{3}{8} - 16 \times 1\frac{1}{4}$	2
	HW-38	Washer, $\frac{3}{8}$	2

INSTALLATION INSTRUCTIONS

- Assemble the tine Segments (Ref 6) to the center lift bar (Ref 5) using the $\frac{3}{8} - 16 \times 1$ Hex Bolts, washers and nuts (Ref 4).
- Mount the right and left caster wheel brackets (Ref 3 and 15) to the center lift bar (Ref 5) using the rest of $\frac{3}{8} - 16 \times 1$ Hex Bolts, washers and nuts (Ref 4 & 13). Mount the last two digger blades at this time using the $\frac{3}{8} - 16 \times 1\frac{1}{4}$ Hex Bolts, washers and nuts (Ref 20 & 13).
- Slide the Scarifier under the machine lining up the hydraulic cylinder and the center of the center lift bar.
- Extend hydraulic cylinder all the way down by pushing the lever forward.
- Mount the rod end of the cylinder onto the center lift bar and secure with a clevis pin (Ref 12) and bridge pin (Ref 1).
- Attach the arms on the center lift bar to the main frame on the machine and secure with clevis pin (Ref 2) and bridge pin (Ref 1).
- Turn machine on and test for proper operation.
- Adjust castor wheels (Ref 12) by placing the short (Ref 16) or long spacer (Ref 18) on the castor wheel fork before placing the castor wheel assembly into the castor wheel brackets. Be sure both castor wheels are adjusted to the same height.

45-011 INFIELD SCARIFIER WITH CHISEL BLADES DRAWING

Center Attachment

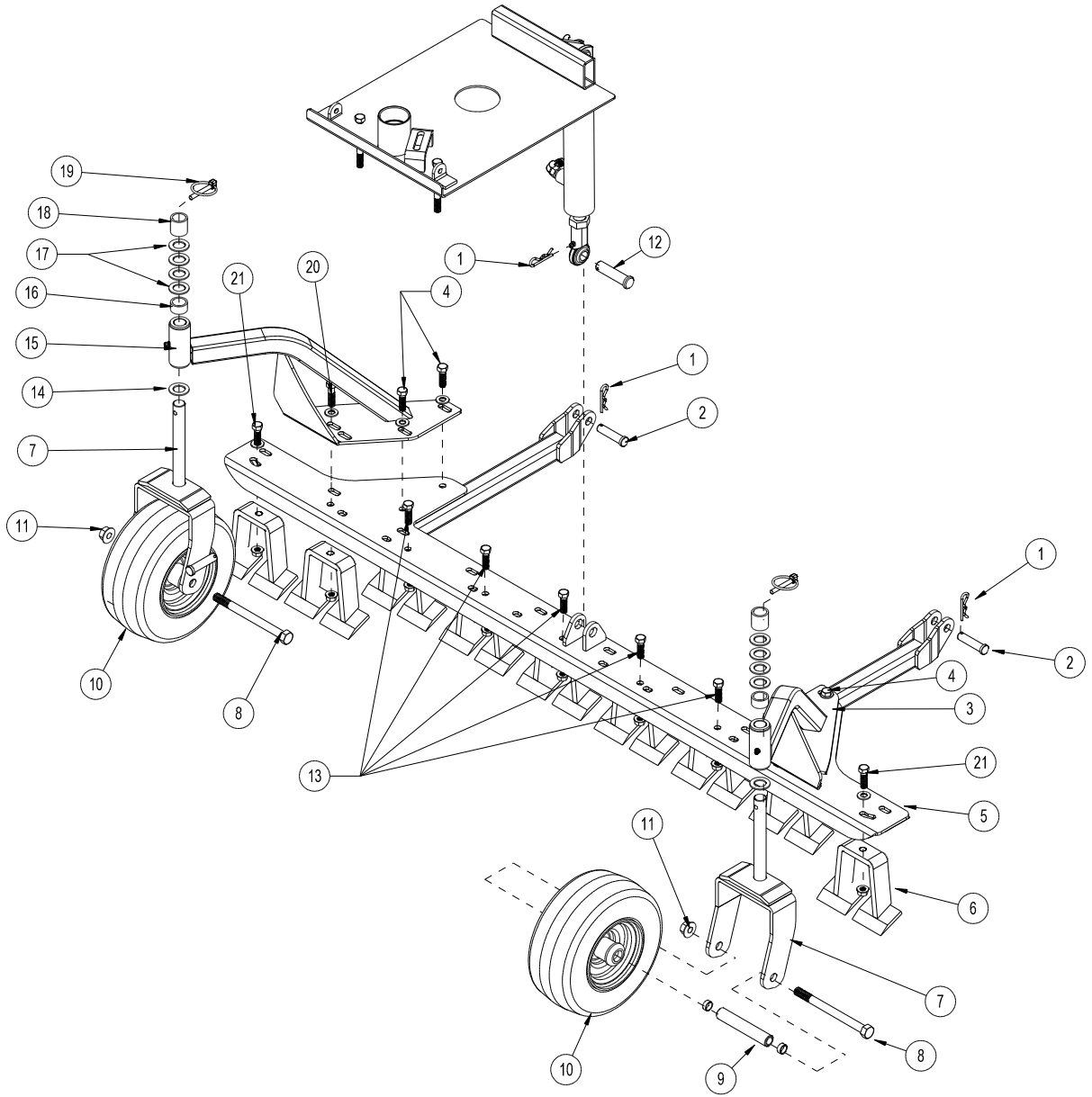

45-011 INFIELD SCARIFIER WITH CHISEL BLADES PARTS LIST

REF#	PART#	DESCRIPTION	QUANTITY
1	HHP-18	Bridge Pin, 1/8	3
2	HCP-12-200	Clevis Pin, 1/2 x 2	2
3	42-205	Left Castor Wheel Bracket	1
	10-025	Flange Bushing (Part of 42-205)	2
	HG-14-28-180	Grease Fitting, 1/4 - 28 x 180° (Part of 42-205)	1
4	HB-38-16-100	Hex Bolt, 3/8 - 16 x 1	4
	HW-38	Washer, 3/8	4
	HNTL-38-16	Nylon Lock Nut, 3/8 - 16	4
5	45-116	Center Lift Bar	1
6	13-114	Digger Blades	9
7	42-204	Castor Fork	2
8	HB-12-13-600	Hex Bolt, 1/2-13 x 6	2
9	33-338	Axle Bearing	2
10	42-202	Tire and Wheel	2
11	HNTL-12-13	Nylon Lock Nut, 1/2 - 13	2
12	HCP-58-250	Clevis Pin, 5/8 x 2 1/2	1
13	HB-38-16-125	Hex Bolt, 3/8 - 16 x 1 1/4	5
	HNTL-38-16	Nylon Lock Nut, 3/8 - 16	5
14	HMB-34-14	Machine Bushing, 3/4 x 14GA	2
15	42-206	Right Castor Wheel Bracket	1
	10-025	Flange Bushing (Part of 42-206)	2
	HG-14-28-180	Grease Fitting, 1/4 - 28 x 180° (Part of 42-206)	1
16	42-215	Short Spacer	2
17	HMB-34-10	Machine Bushing, 3/4 x 10GA	8
18	42-214	Long Spacer	2
19	42-539	Lynch Pin, 5/16	2
20	HB-38-16-150	Hex Bolt, 3/8 - 16 x 1 1/2	2
	HW-38	Flat Washer, 3/8	2
	HNTL-38-16	Nylon Lock Nut, 3/8 - 16	2
21	HB-38-16-125	Hex Bolt, 3/8 - 16 x 1 1/4	2
	HW-38	Flat Washer, 3/8	2
	HNTL-38-16	Nylon Lock Nut, 3/8 - 16	2

INSTALLATION INSTRUCTIONS

- Assemble seven digger blades (Ref 6) to the center lift bar (Ref 5) using the 3/8 - 16 x 1 1/4 Hex Bolts, washers and nuts (Ref 21) on the outside slots and 3/8 - 16 x 1 Hex Bolts and nuts (Ref 13) on the holes. Do not put the two digger blades on that mount with the caster arm hardware (Ref 20).
- Mount the right and left caster wheel brackets (Ref 3 and 15) to the center lift bar (Ref 5) using 3/8 - 16 x 1 Hex Bolts, washers and nuts (Ref 4). Mount the last two digger blades at this time using the 3/8 - 16 x 1 1/2 Hex Bolts, washers and nuts (Ref 20).
- Slide the Scarifier under the machine lining up the hydraulic cylinder and the center of the center lift bar.
- Extend hydraulic cylinder all the way down by pushing the lever forward.
- Mount the rod end of the cylinder onto the center lift bar and secure with a clevis pin (Ref 12) and bridge pin (Ref 1).
- Attach the arms on the center lift bar to the main frame on the machine and secure with clevis pin (Ref 2) and bridge pin (Ref 1).
- Turn machine on and test for proper operation.
- Adjust castor wheels (Ref 12) by placing the short (Ref 16) or long spacer (Ref 18) on the castor wheel fork before placing the castor wheel assembly into the castor wheel brackets. Be sure both castor wheels are adjusted to the same height.

45-195 GRADER BLADE DRAWING

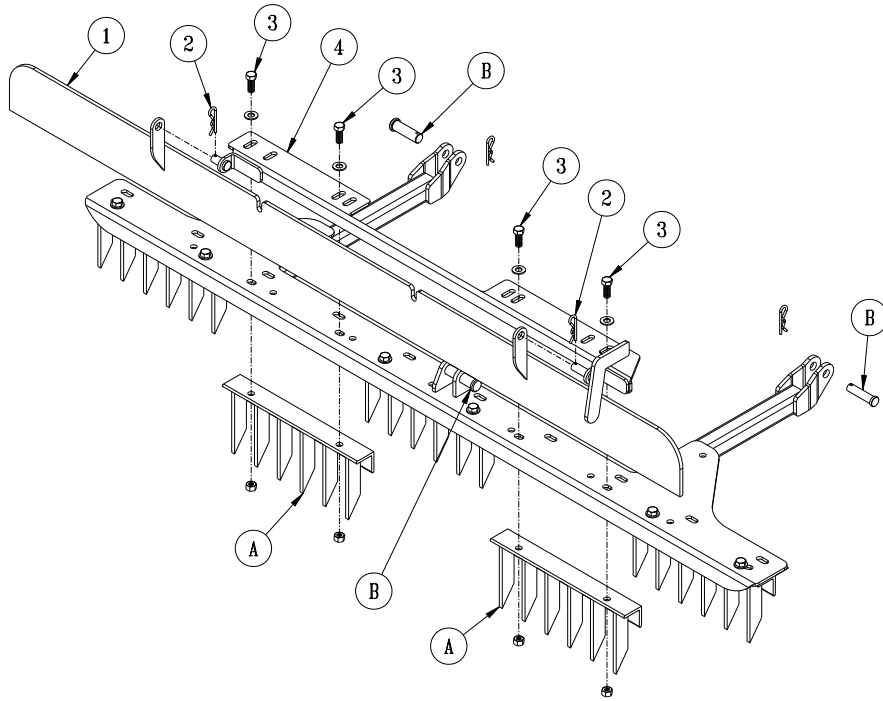

Center Attachment

45-195 GRADER BLADE CARRIER DRAWINGS

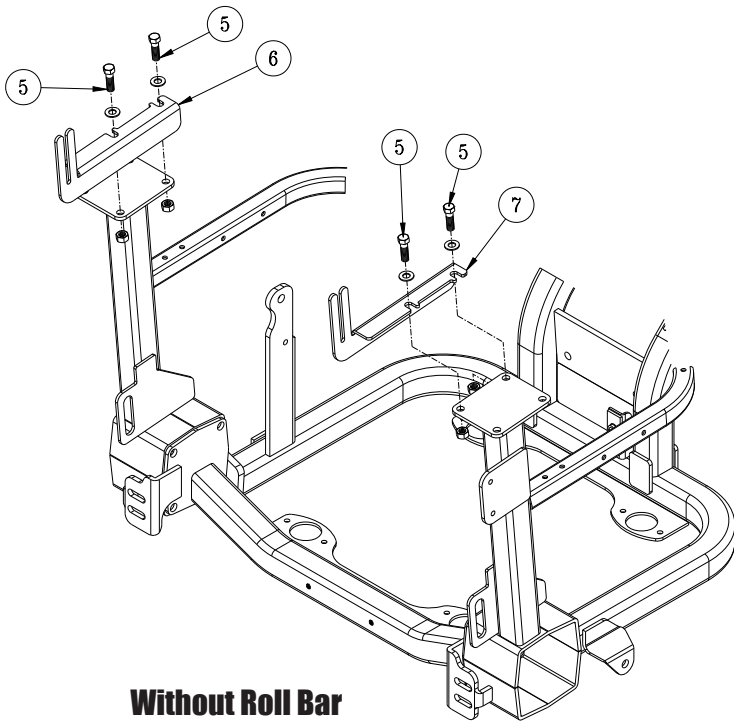

Without Roll Bar

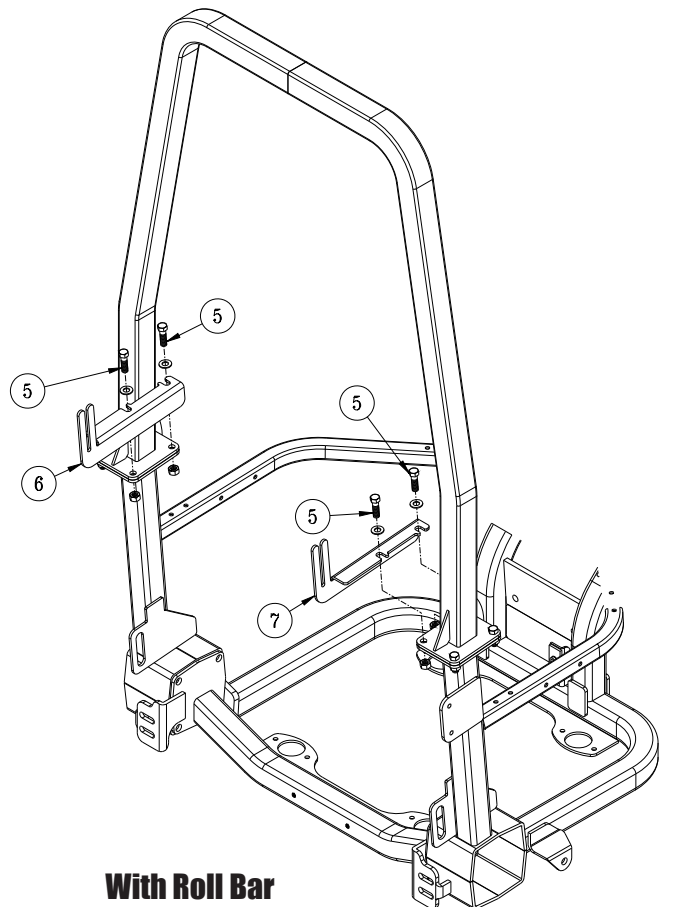

With Roll Bar

45-195 GRADER BLADE PARTS LIST

REF#	PART#	DESCRIPTION	QTY
1	42-207	Grader Blade	1
2	HHP-18	Bridge Pin, $\frac{1}{8}$	2
3	HB-38-16-125	Hex Bolt, $\frac{3}{8}$ - 16 x $1\frac{1}{4}$	4
	HW-38	Flat Washer, $\frac{3}{8}$	4
4	45-190	Blade Mount	1
5	HB-716-14-150	Hex Bolt, $\frac{7}{16}$ - 14 x $1\frac{1}{2}$	4
	HNTL-716-14	Nylon Nylon Lock Nut, $\frac{7}{16}$ - 14	4
	HW-716	Flat Washer, $\frac{7}{16}$	4
6	45-191	LH Carrier Bracket	1
7	45-192	RH Carrier Bracket	1

45-195 GRADER BLADE INSTALLATION INSTRUCTIONS

1. Lower center attachment to the ground and remove the 3 Clevis Pins(Ref. B).
2. Remove the (4) Hex Bolts holding each of Blades(Ref A) to the right and left of the center blade. Set the Blades and (4) Nylon Lock Nuts aside.
3. Place the Blade Mount(Ref. 4) on top of the attachment frame, lining up the slots where the Hex Bolts were removed. Replace the removed Hex Bolts with the included $\frac{3}{8}$ -16 x $1\frac{1}{4}$ Hex Bolts and $\frac{3}{8}$ Flat Washers(Ref 3). Reinstall the Blades(Ref. A) and secure using the $\frac{3}{8}$ -16 Nylon Lock Nuts that were set aside.
4. Check all hardware for tightness.
5. Reinstall center attachment. Slide the Grader Blade(Ref. 1) onto the pins, as illustrated, and secure using the Bridge Pins(Ref 2).
- 6a. *To install the Carrier Brackets on a machine without a roll bar:*
Mount the RH Carrier Bracket(Ref. 7) and LH Carrier Bracket(Ref. 6) to the to the ROPS towers using the inside set of holes. Secure each Bracket using the $\frac{7}{16}$ -14 x $1\frac{1}{2}$ Hex Bolts, $\frac{7}{16}$ Flat Washers and $\frac{7}{16}$ -14 Nylon Lock Nuts.
- 6b. *To install the Carrier Brackets on a machine with a roll bar:*
Remove the (4) inside Hex Bolts, position each Carrier Bracket(Refs. 6 & 7) over the holes and use the $\frac{7}{16}$ -14 x $1\frac{1}{2}$ Hex Bolts, $\frac{7}{16}$ Flat Washers and $\frac{7}{16}$ -14 Nylon Lock Nuts to secure.
7. When placing the Grader Blade in the Carriers point the mounting tabs downward as shown in the photo below.

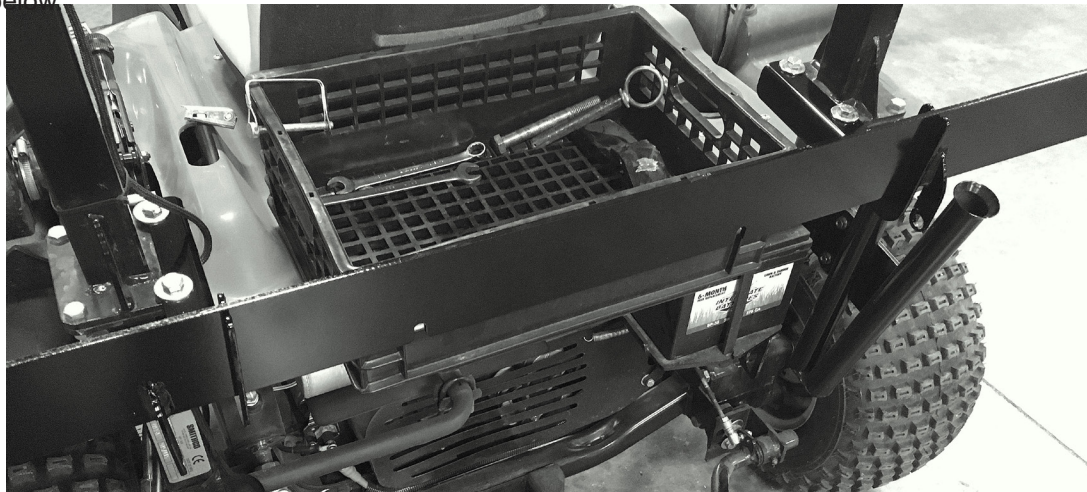

45-175 ADJUSTABLE DISC EDGER DRAWING

Center Attachment

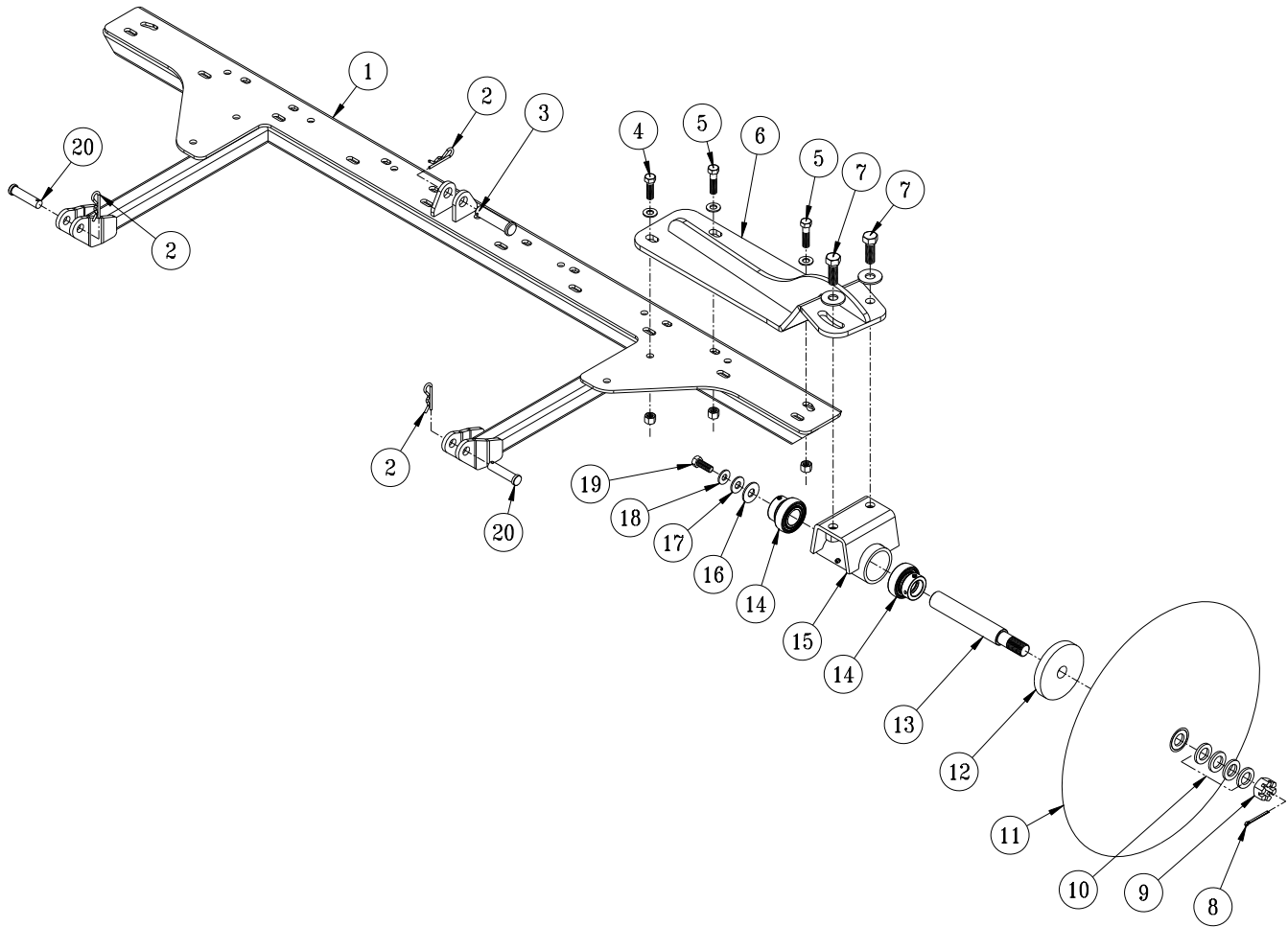

45-175 ADJUSTABLE DISC EDGER PARTS LIST

REF#	PART#	DESCRIPTION	QUANTITY
1	45-116	Center Lift	1
2	HHP-18	Bridge Pin, $\frac{1}{8}$	3
3	HCP-58-250	Clevis Pin, $\frac{5}{8} \times 2\frac{1}{2}$	1
4	HB-38-16-125	Hex Bolt, $\frac{3}{8}$ - 16 x $1\frac{1}{4}$	1
	HW-38	Washer, $\frac{3}{8}$	1
	HNTL-38-16	Nylon Lock Nut, $\frac{3}{8}$ -16	1
5	HB-38-16-150	Hex Bolt, $\frac{3}{8}$ - 16 x $1\frac{1}{2}$	2
	HW-38	Flat Washer, $\frac{3}{8}$	2
	HNTL-38-16	Nylon Lock Nut, $\frac{3}{8}$ - 16	2
6	45-166	Edger Mount	1
7	HB-12-13-150	Hex Bolt, $\frac{1}{2}$ - 13 x $1\frac{1}{2}$	2
	HW-12	Flat Washer, $\frac{1}{2}$	2
	HNTL-12-13	Nylon Lock Nut, $\frac{1}{2}$ - 13	2
8	HP-18-150	Cotter Pin, $\frac{1}{8} \times 1\frac{1}{2}$	1
9	HNA-34-16	Axle Nut, $\frac{3}{4}$ - 16	1
10	HMB-34-10	Machine Bushing, $\frac{3}{4} \times 10GA$	4
11	13-204	Disc	1
12	13-205	Disc Flange	1
13	13-206	Spindle Shaft	1
14	13-391	Bearing and Collar	2
15	13-203	Spindle	1
	HG-14-28-180	Grease Fitting	1
16	HW-716	Flat Washer, $\frac{7}{16}$	1
17	HWL-38	Lock Washer, $\frac{3}{8}$	1
18	HW-516	Flat Washer, $\frac{5}{16}$	1
19	HB-38-16-100	Hex Bolt, $\frac{3}{8}$ -16 x 1	1
20	HCP-12-200	Clevis Pin, $\frac{1}{2} \times 2$	2
*	Spindle Assembly		

INSTALLATION INSTRUCTIONS

- For initial assembly, Hex Bolt Spindle Assembly (**Ref. 13 thru 19**) to the Edger Mount (**Ref. 6**). Use the $\frac{1}{2}$ - 13 Hex Bolts, Washers and Nylon Lock Nuts (**Ref. 7**) to secure.
- Slide the Disc Flange (**Ref. 12**) on the Spindle Shaft (**Ref. 13**) up to the shoulder. Then place the Disc (**Ref.11**) onto the shaft, orienting the concave side towards the Spindle followed by the four Machine Bushings (**Ref. 10**), and the axle nut (**Ref. 9**).
- Tighten Axle Nut, insert and clinch the Cotter Pin (**Ref. 8**).
- Connect the Edger Mount onto the Center Lift (**Ref.1**) using the $\frac{3}{8}$ Hex Bolts, Washers and Nylon Lock Nuts (**Refs. 4 & 5**), with the $1\frac{1}{4}$ " Hex Bolt (**Ref. 4**) going into the last hole on the Mount Plate.
- The Edger mounts under the center of the trap rake.
- Start the engine and lower the cylinder for the attachment lift FULLY. Stop engine.
- Slide Edger under the trap rake from the right side.
- Position the lift arms on the attachment lift assembly to the lift brackets on the machine. Hold in place with $\frac{1}{2} \times 2$ clevis pin and bridge pins (**Refs. 2 & 20**).
- Attach the cylinder to the center tab on the Center Lift using the $\frac{5}{8} \times 2\frac{1}{2}$ Clevis Pin and Bridge Pin (**Refs. 2 & 3**).
- Start engine and test lift and Edger to make sure all works well.

45-177 NAIL SCARIFIER WITH CASTOR WHEELS DRAWING

Center Attachment

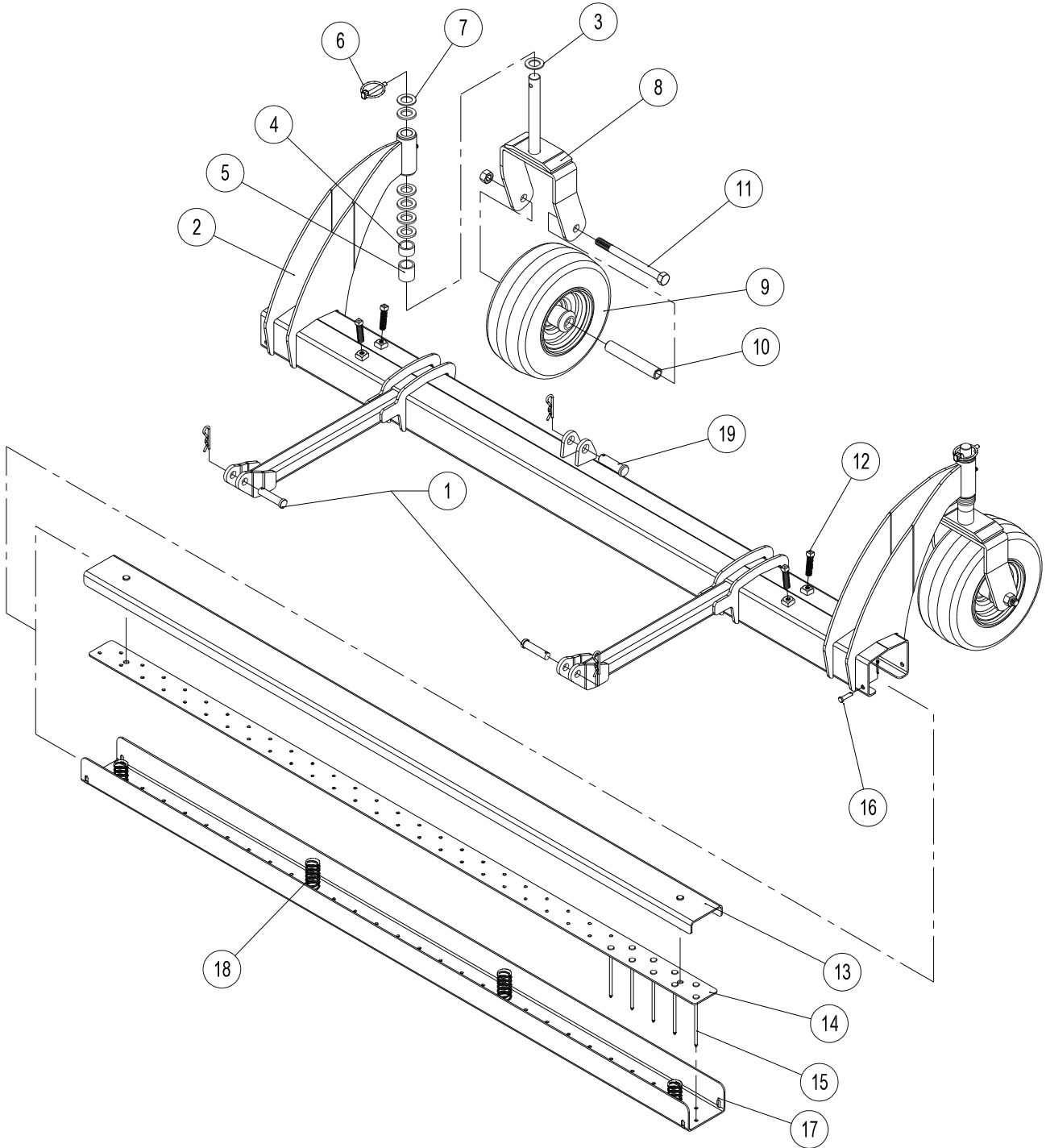

45-177 NAIL SCARIFIER WITH CASTOR WHEELS PARTS LIST

REF#	PART#	DESCRIPTION	QUANTITY
1	HCP-12-200	Clevis Pin, 1/2 x 2	2
	HHP-18	Bridge Pin, 1/8	2
2	45-171	Nail Scarifier Frame	1
	10-025	Flange Bushing (Part of 43-171)	4
	HG-14-28-180	Grease Fitting, 1/4 - 28 x 180° (Part of 43-171)	2
3	HMB-34-14	Machine Bushing, 3/4 x 14GA	2
4	42-215	Short Spacer	2
5	42-214	Long Spacer	2
6	42-539	Lynch Pin, 1/4"	2
7	HMB-34-10	Machine Bushing, 3/4 x 10GA	12
8	42-204	Castor Fork	2
9	42-202	Tire & Wheel	2
10	33-338	Axle Bearing	2
11	HB-12-13-600	Hex Bolt, 1/2 - 13 x 6	2
	HNTL-12-13	Nylon Lock Nut, 1/2 - 13	2
12	HSSQS-38-16-150	SS Sq. Head Set Screw, 3/8 - 16 x 1 1/2	4
	HN-38-16	Hex Nut, 3/8 - 16	4
13	45-172	Nail Channel Cover	1
14	45-170	Nail Plate	1
15	9028	Spiral Shank Nail, 7GA x 4"	57
16	HCP-14-075	Clevis Pin, 1/4 x 3/4	1
	HP-332-075	Cotter Pin, 3/8 x 3/4	1
17	45-169	Nail Channel	1
18	43-175	Compression Spring	4
19	HCP-58-200	Clevis Pin, 5/8 x 2	1
	HHP-18	Bridge Pin, 1/8	1

Center Attachment

42-391Q 72"(183CM) ProBrush TOURNAMENT RAKE DRAWING

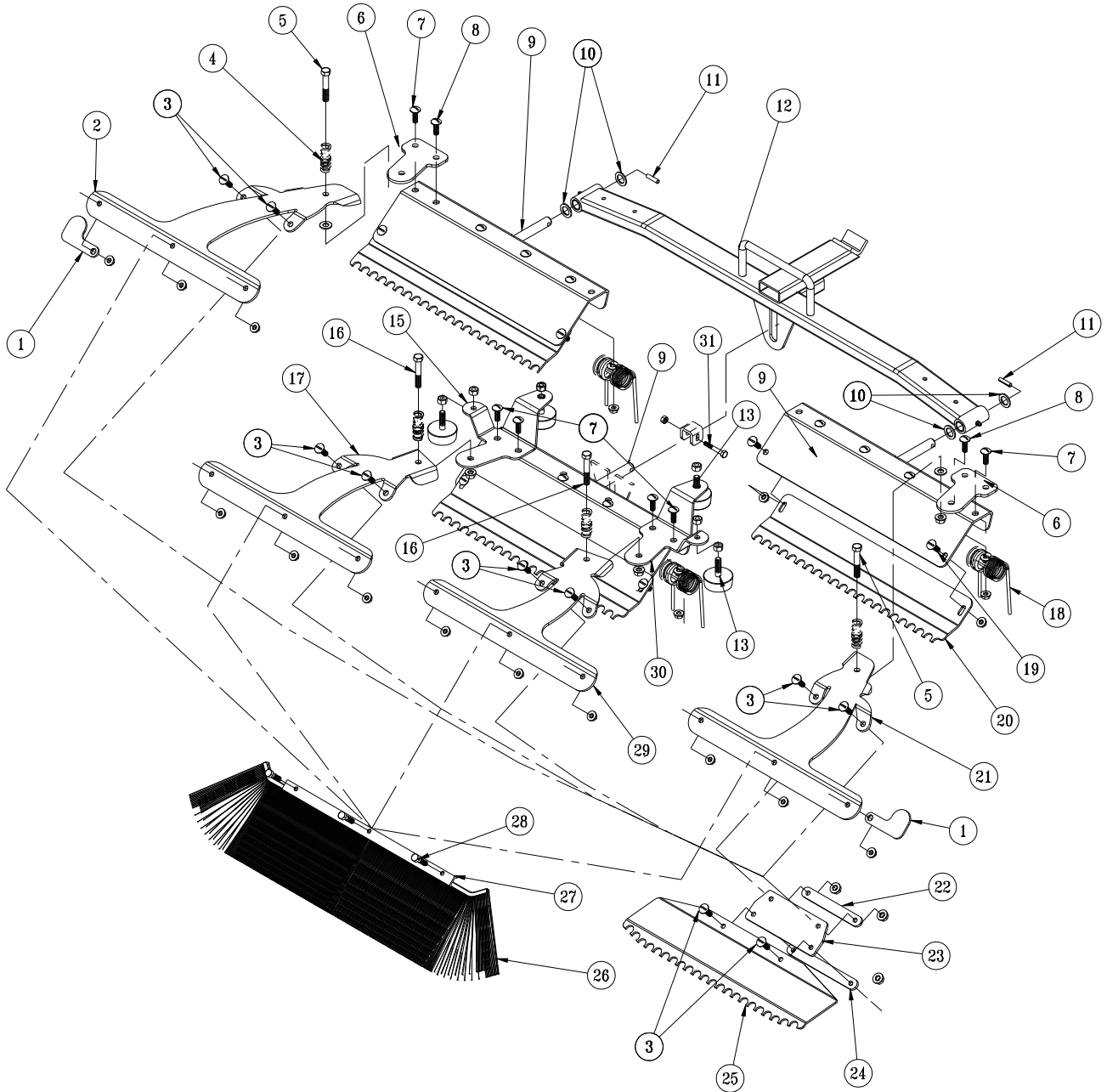

Rear Attachment

42-391Q 72"(183CM) ProBrush TOURNAMENT RAKE PARTS LIST

REF#	PART#	DESCRIPTION	QUANTITY
1	42-489	Tip Guard	2
2	42-397	Outside Brush Arm, LH	1
3	HSTP-516-18-100	Phillip Truss Head Screw, $\frac{5}{16}$ - 18 x 1	16
	HNFL-516-18	Flange Whiz-Loc Nut, $\frac{5}{16}$ - 18	16
4	11-055	Compression Spring	4
5	HB-38-16-275	Hex Bolt, $\frac{3}{8}$ - 16 x 2 $\frac{3}{4}$	2
	HW-38	Flat Washer, $\frac{3}{8}$	2
	HNTL-38-16	Nylon Lock Nut, $\frac{3}{8}$ - 16	2
6	42-396	Outside Brush Arm Mount	2
7	HSTP-516-18-100	Phillips Truss Head Screw, $\frac{5}{16}$ - 18 x 1	4
	HNFL-516-18	Flange Whiz-Loc Nut, $\frac{5}{16}$ - 18	4
8	HSTP-516-18-125	Phillips Truss Head Screw, $\frac{5}{16}$ - 18 x 1 $\frac{1}{4}$	12
	HNFL-516-18	Flange Whiz-Loc Nut, $\frac{5}{16}$ - 18	12
9	42-140	Outside Rake	3
10	HMB-58-14	Machine Bushing, $\frac{5}{8}$ x 14GA	4
11	HRP-14-100	Roll Pin, $\frac{1}{4}$ x 1	2
12	43-154	Draw Bar	1
	20-018	Oilite Bushing (comes with 43-154)	4
13	50-081	Rubber Bumper	4
	HNFL-38-16	Flange Whiz-loc Nut, $\frac{3}{8}$ - 16	6
15	42-399	Brush Arm Mount, LH	1
16	HB-38-16-250	Hex Bolt, $\frac{3}{8}$ - 16 x 2 $\frac{1}{2}$	2
	HNTL-38-16	Nylon Lock Nut, $\frac{3}{8}$ - 16	2
17	42-454	Inside Brush Arm, LH	1
18	42-122	Rake Spring	12
	42-177	Spring Holder	12
19	HSTP-516-18-075	Phillip Truss Head Screw, $\frac{5}{16}$ - 18 x $\frac{3}{4}$	6
	HNFL-516-18	Flange Whiz-Loc Nut, $\frac{5}{16}$ - 18	6
20	42-171	Groomer Blades	3
21	42-393	Outside Brush Arm, RH	1
22	42-105	Top Strap	4
23	42-107	Matting	4
24	42-106	Bottom Strap	4
25	42-170	Finishing Blades	4
26	42-466	Brush, 21"	4
27	42-465	Brush Clamp	4
28	HB-516-18-125	Hex Bolt, $\frac{5}{16}$ - 18 x 1 $\frac{1}{4}$	12
	HNFL-516-18	Flange Whiz-Loc Nut, $\frac{5}{16}$ - 18	12
29	42-453	Inside Brush Arm, RH	1
30	42-398	Brush Arm Mount, RH	1
31	HB-14-20-175	Hex Bolt, $\frac{1}{4}$ - 20 x 1 $\frac{3}{4}$	1
	HNTL-14-20	Nylon Lock Nut, $\frac{1}{4}$ - 20	1

42-391Q 72"(183CM) ProBRUSH TOURNAMENT RAKE DRAWING

Fig. 1

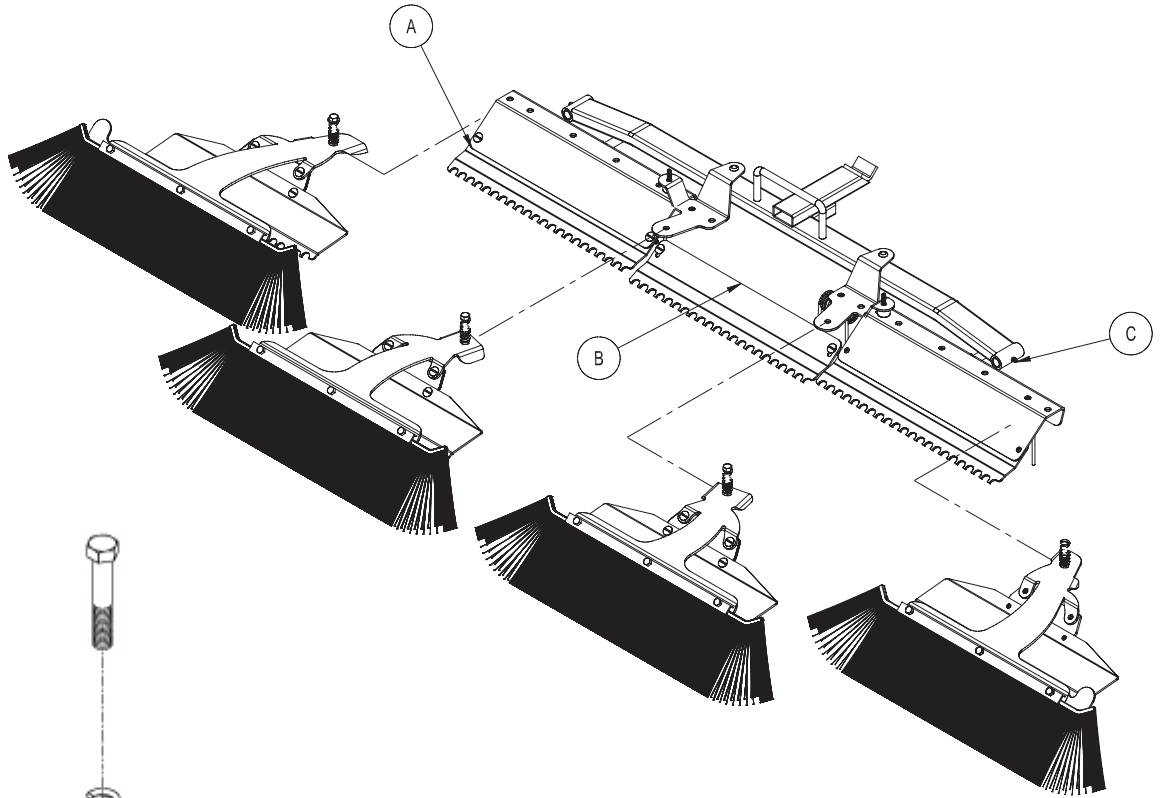

Fig. 2

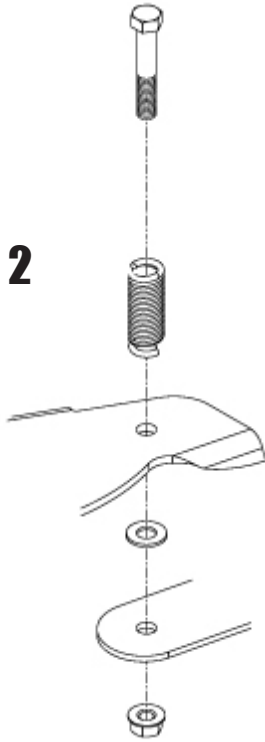

Fig. 3

PROBRUSH TOURNAMENT RAKE ASSEMBLY INSTRUCTIONS

Your **ProBrush TOURNAMENT RAKE** comes mostly assembled.

1. Before assembly please note the two Brush/Finish Blade Assemblies (Refs A & C in Fig.1) that are mounted on the outside (RH & LH) have flat washers that are between the Brush Arms (Refs 2 & 21) and the Brush Arm Mount (Ref 6).
2. Also please note the placement of the Brush/Finish Blade Assemblies as illustrated in Fig 1. They must be mounted as illustrated to work as intended.
3. Begin assembling your **ProBrush TOURNAMENT RAKE** by inserting the Outside and Center Groomer Blade Assemblies (Refs A, B & C in Fig.1) in their locations as illustrated. Secure the Outside Assemblies with the $\frac{1}{4}$ " Pin (Ref 11) and the Center Assembly with the $\frac{1}{4}$ " x $1\frac{3}{4}$ " Hex Bolt and Nylon Lock Nut (Ref 31).
4. Mount the Brush/Finish Blade Assemblies to the Brush Arm Mounts (Refs 6, 30 & 15) as illustrated using the $\frac{3}{8}$ " x $2\frac{1}{2}$ " Hex Bolts and Nylon Lock Nuts. Assemble with the Springs (Ref 4) as shown in Fig. 2. Please note that the $\frac{3}{8}$ " Flat Washers are used only on the Outside Assemblies. Secure when assembled.
5. Mount your **ProBrush TOURNAMENT RAKE** to the trap rake quick hitch. Position the Rake so it is centered and equal distance away from the right and left hand tires (2-3 inches). Fig. 4. Once positioned, set the Adjustment Screws on the Hitch so they touch the trap rake hitch. Fig. 5.
6. Run machine and test for operation of the Rake by raising and lowering the assembly and with rake down turn sharp corners in both directions to ensure rake is not contacting the tires. Test Rake in sand to ensure tire tracks are covered when turning sharp corners. If the tire tracks are not covered by the Rake, turn the Adjustment Screws on the Rake Hitch so the rake comes closer to the tires when turning. For reference see Fig. 4 and 5 below.

NOTE:

The Outside Brush/Finish Blade Assemblies may be rotated 180° for transport and for working in narrow areas, as illustrated in Fig.3 on the facing page.

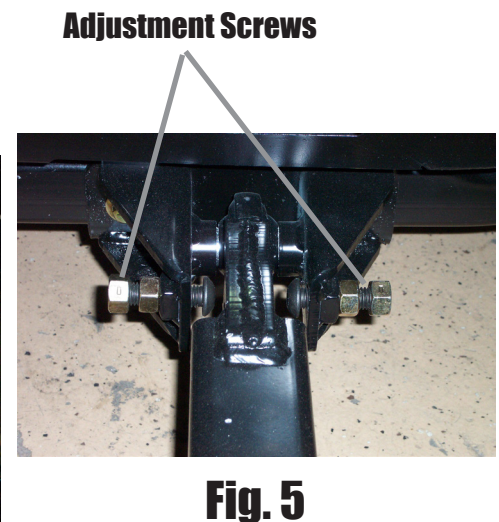
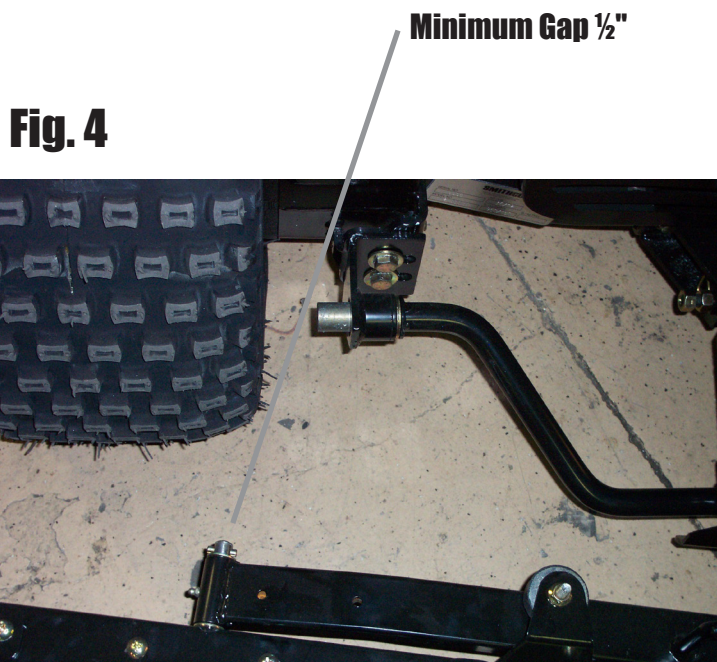

42-392Q 84"(213CM) ProBRUSH TOURNAMENT RAKE DRAWING

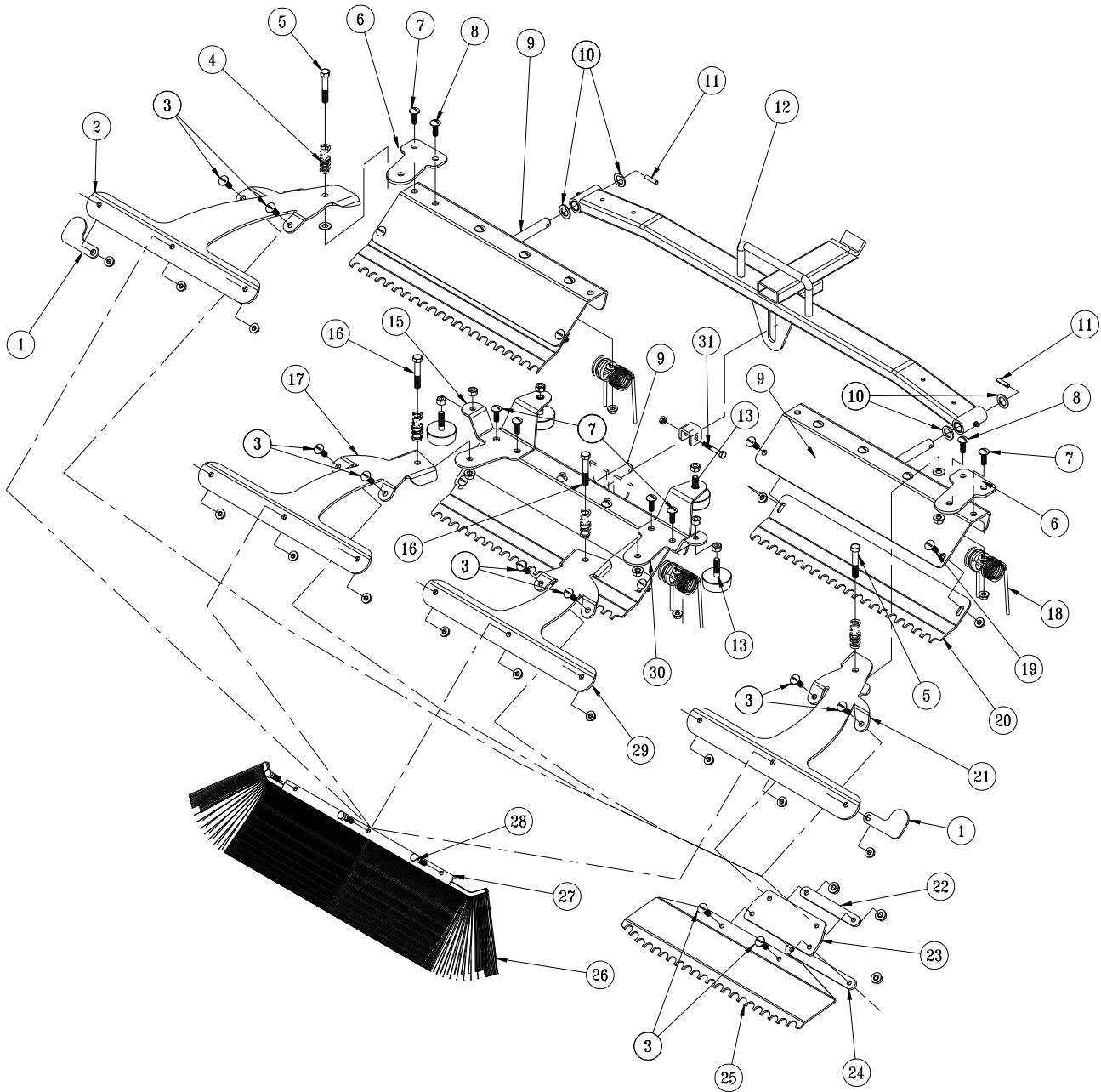

Rear Attachment

42-392Q 84"(213CM) ProBrush TOURNAMENT RAKE PARTS LIST

REF#	PART#	DESCRIPTION	QUANTITY
1	42-489	Tip Guard	2
2	42-397	Outside Brush Arm, LH	1
3	HSTP-516-18-100	Phillip Truss Head Screw, $\frac{5}{16}$ - 18 x 1	16
	HNFL-516-18	Flange Whiz-Loc Nut, $\frac{5}{16}$ - 18	16
4	11-055	Compression Spring	4
5	HB-38-16-250	Hex Bolt, $\frac{3}{8}$ - 16 x 2 $\frac{1}{2}$	2
	HW-38	Flat Washer, $\frac{3}{8}$	2
	HNTL-38-16	Nylon Lock Nut, $\frac{3}{8}$ - 16	2
6	42-396	Outside Brush Arm Mount	2
7	HSTP-516-18-100	Phillips Truss Head Screw, $\frac{5}{16}$ - 18 x 1	4
	HNFL-516-18	Flange Whiz-Loc Nut, $\frac{5}{16}$ - 18	4
8	HSTP-516-18-125	Phillips Truss Head Screw, $\frac{5}{16}$ - 18 x 1 $\frac{1}{4}$	12
	HNFL-516-18	Flange Whiz-Loc Nut, $\frac{5}{16}$ - 18	12
9	42-102	84" Outside Rake	3
10	HMB-58-14	Machine Bushing $\frac{5}{8}$ x 14GA	4
11	HRP-14-100	Roll Pin $\frac{1}{4}$ x 1	2
12	43-144	84" Draw Bar	1
13	50-081	Rubber Bumper	4
	HNFL-38-16	Flange Whiz-loc Nut, $\frac{3}{8}$ - 16	6
15	42-399	Brush Arm Mount, LH	1
16	HB-38-16-250	Hex Bolt, $\frac{3}{8}$ - 16 x 2 $\frac{1}{2}$	2
	HNTL-38-16	Nylon Lock Nut, $\frac{3}{8}$ - 16	2
17	42-454	Inside Brush Arm, LH	1
18	42-122	Rake Spring	12
	42-177	Spring Holder	12
19	HSTP-516-18-075	Phillip Truss Head Screw, $\frac{5}{16}$ - 18 x $\frac{3}{4}$	6
	HNFL-516-18	Flange Whiz-Loc Nut, $\frac{5}{16}$ - 18	6
20	42-129	Groomer Blades	3
21	42-393	Outside Brush Arm, RH	1
22	42-105	Top Strap	4
23	42-107	Matting	4
24	42-106	Bottom Strap	4
25	42-135	Finishing Blades	4
26	42-466	Brush, 21"	4
27	42-465	Brush Clamp	4
28	HB-516-18-125	Hex Bolt, $\frac{5}{16}$ - 18 x 1 $\frac{1}{4}$	12
	HNFL-516-18	Flange Whiz-Loc Nut, $\frac{5}{16}$ - 18	12
29	42-453	Inside Brush Arm, RH	1
30	42-398	Brush Arm Mount, RH	1
31	HB-14-20-175	Hex Bolt, $\frac{1}{4}$ - 20 x 1 $\frac{3}{4}$	1
	HNTL-14-20	Nylon Lock Nut, $\frac{1}{4}$ - 20	1

42-392Q 84"(213CM) ProBRUSH TOURNAMENT RAKE DRAWING

Fig. 1

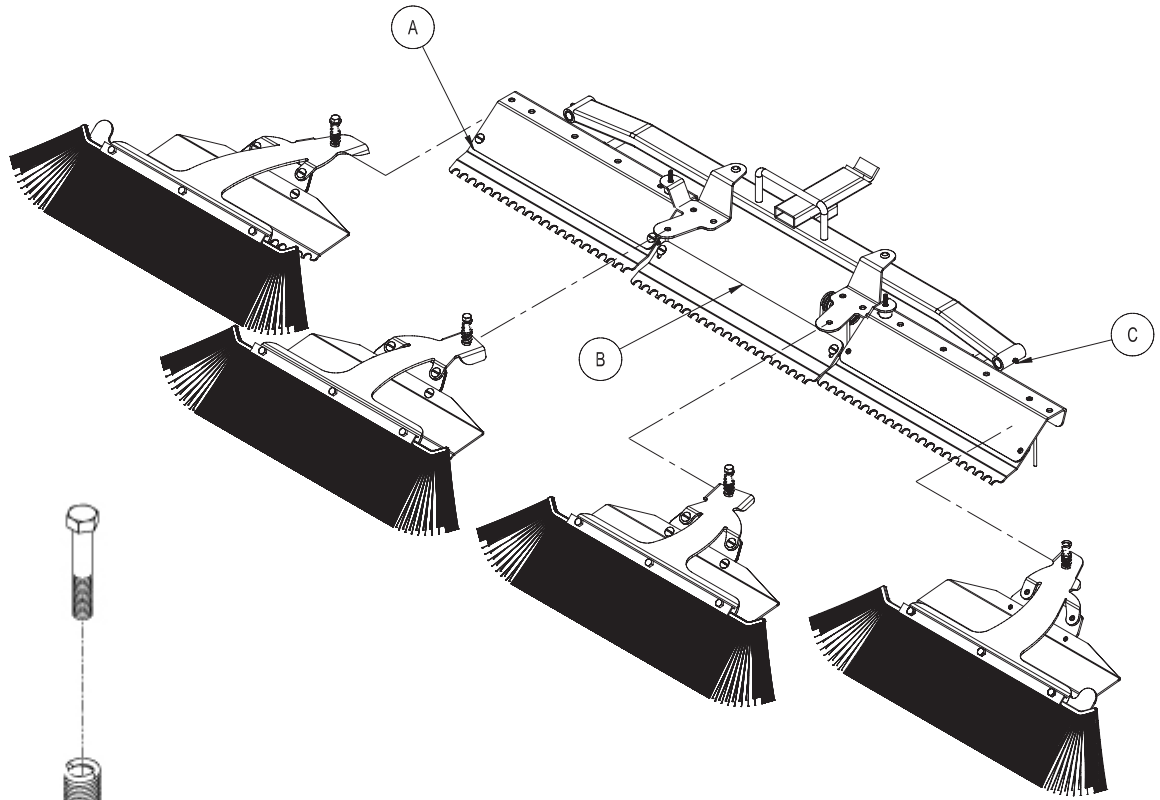

Fig.

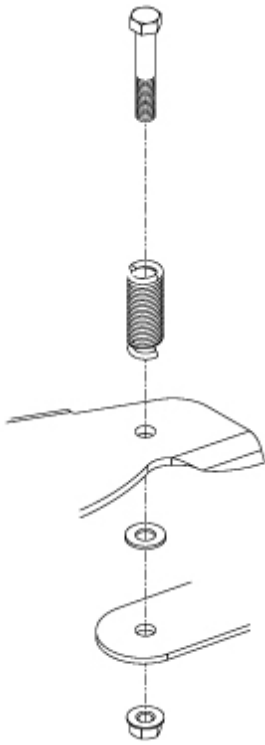

Fig. 3

Rear Attachment

PROBRUSH TOURNAMENT RAKE ASSEMBLY INSTRUCTIONS

Your **ProBrush TOURNAMENT RAKE** comes mostly assembled.

1. Before assembly please note the two Brush/Finish Blade Assemblies (Refs A & C in Fig.1) that are mounted on the outside (RH & LH) have flat washers that are between the Brush Arms (Refs 2 & 21) and the Brush Arm Mount (Ref 6).
2. Also please note the placement of the Brush/Finish Blade Assemblies as illustrated in Fig 1. They must be mounted as illustrated to work as intended.
3. Begin assembling your **ProBrush TOURNAMENT RAKE** by inserting the Outside and Center Groomer Blade Assemblies (Refs A, B & C in Fig.1) in their locations as illustrated. Secure the Outside Assemblies with the $\frac{1}{4}$ " Pin (Ref 11) and the Center Assembly with the $\frac{1}{4}$ " x $1\frac{3}{4}$ " Hex Bolt and Nylon Lock Nut (Ref 31).
4. Mount the Brush/Finish Blade Assemblies to the Brush Arm Mounts (Refs 6, 30 & 15) as illustrated using the $\frac{3}{8}$ " x $2\frac{1}{2}$ " Hex Bolts and Nylon Lock Nuts. Assemble with the Springs (Ref 4) as shown in Fig. 2. Please note that the $\frac{3}{8}$ " Flat Washers are used only on the Outside Assemblies. Secure when assembled.
5. Mount your **ProBrush TOURNAMENT RAKE** to the trap rake quick hitch. Position the Rake so it is centered and equal distance away from the right and left hand tires (2-3 inches). Fig. 4. Once positioned, set the Adjustment Screws on the Hitch so they touch the trap rake hitch. Fig. 5.
6. Run machine and test for operation of the Rake by raising and lowering the assembly and with rake down turn sharp corners in both directions to ensure rake is not contacting the tires. Test Rake in sand to ensure tire tracks are covered when turning sharp corners. If the tire tracks are not covered by the Rake, turn the Adjustment Screws on the Rake Hitch so the rake comes closer to the tires when turning. For reference see Fig. 4 and 5 below.

NOTE:

The Outside Brush/Finish Blade Assemblies may be rotated 180° for transport and for working in narrow areas, as illustrated in Fig.3 on the facing page.

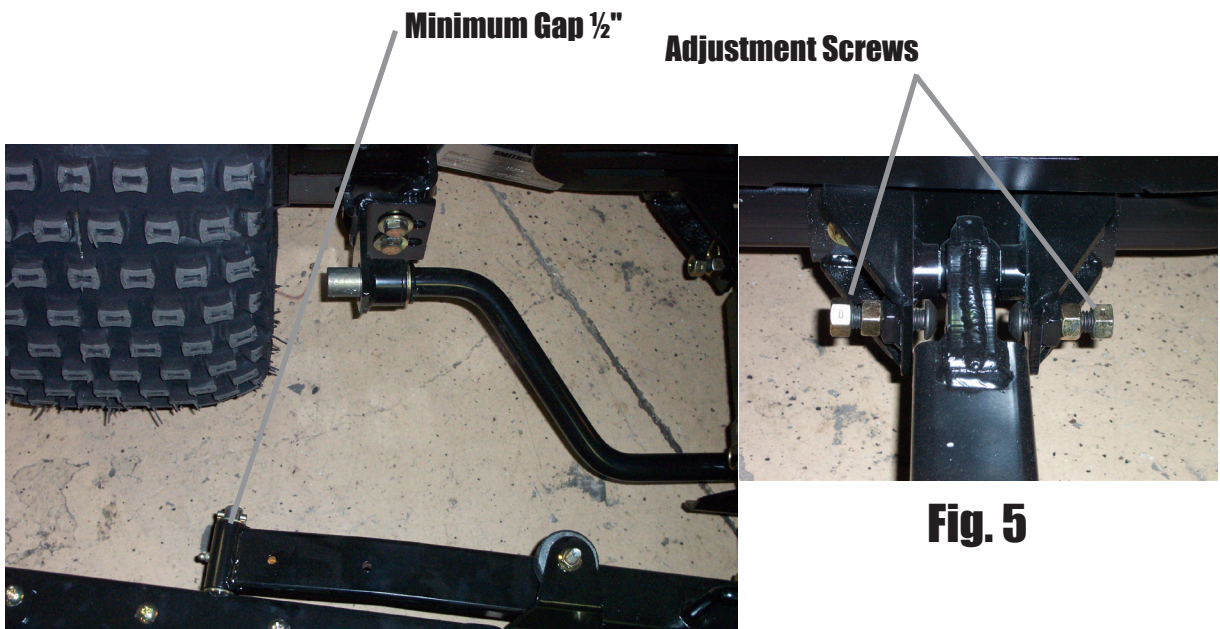
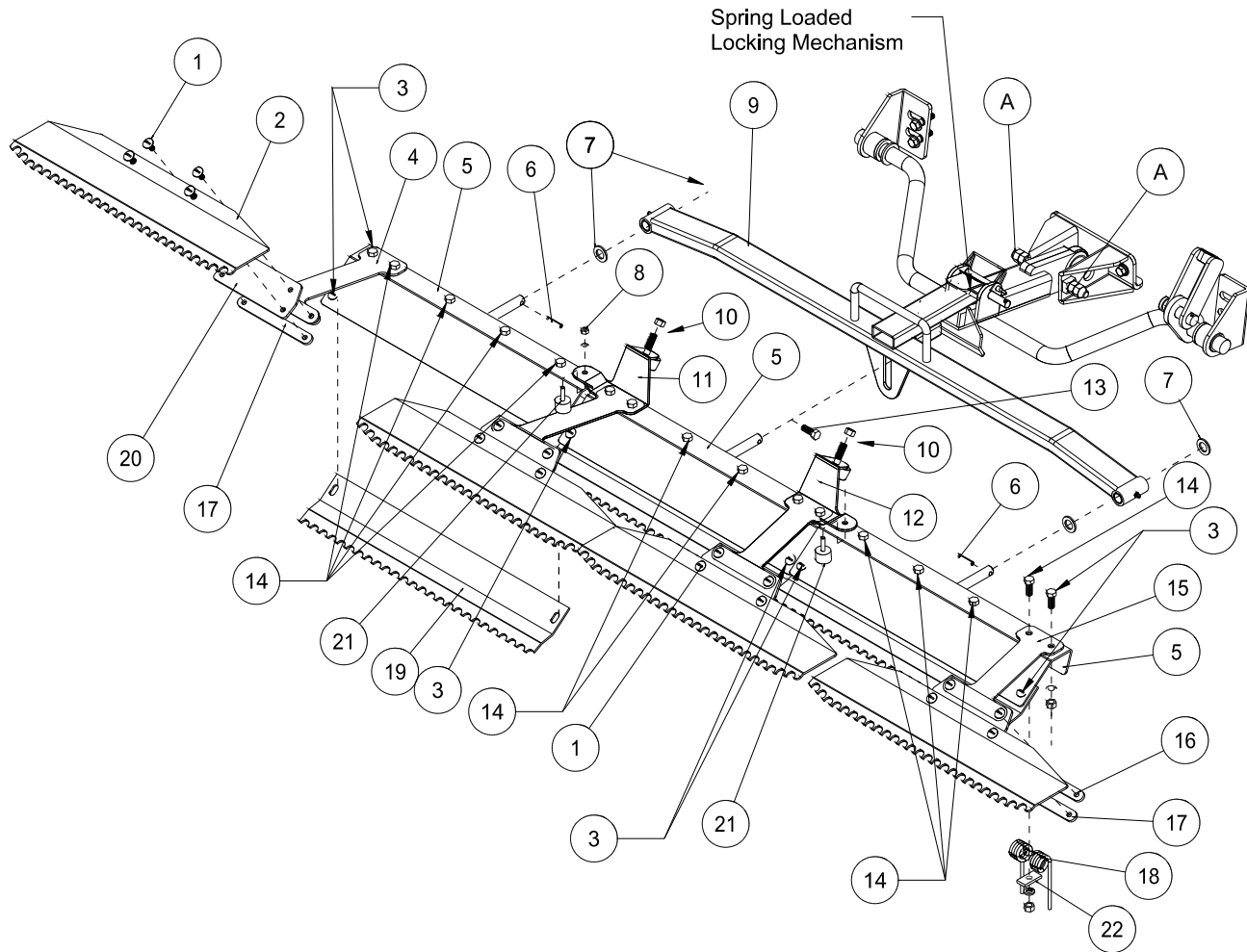

Fig. 4

Fig. 5

42-130Q 84" (213CM) MILD STEEL TOURNAMENT RAKE DRAWING



Rear Attachment

42-130Q 84" (213CM) MILD STEEL TOURNAMENT RAKE PARTS LIST

REF#	PART#	DESCRIPTION	QUANTITY
1	HSTP-516-18-100	Phillips Machine Screw, $\frac{5}{16}$ - 18 x 1	16
	HNFL-516-18	Flange Whiz-loc Nut, $\frac{5}{16}$ - 18	16
2	42-135	Finishing Blades	4
3	HSTP-516-18-075	Phillips Machine Screw, $\frac{5}{16}$ - 18 x $\frac{3}{4}$	8
	HNFL-516-18	Flange Whiz-loc Nut, $\frac{5}{16}$ - 18	8
4	42-111	Left Outside Mount	1
5	42-102	Outside Rake	3
6	HRP-14-100	Roll Pin, $\frac{1}{4}$ x 1	2
7	HMB-58-14	Machine Bushing, $\frac{5}{8}$ x 14GA	4
8	HNC-14-20	Cap Nut, $\frac{1}{4}$ - 20	2
	HWL-14	Lock Washer, $\frac{1}{4}$	2
9	43-144	Draw Bar	1
10	50-081	Rubber Bumper	2
11	42-110	Left Inside Mount	1
12	42-108	Inside Trowel Mount	1
13	HB-14-20-175	Hex Bolt, $\frac{1}{4}$ - 20 x $1\frac{3}{4}$	1
	HNTL-14-20	Nylon Lock Nut, $\frac{1}{4}$ - 20	1
14	HSTP-516-18-125	Phillips Machine Screw, $\frac{5}{16}$ - 18 x $1\frac{1}{4}$	12
	HNFL-516-18	Flange Whiz-loc Nut, $\frac{5}{16}$ - 18	12
15	42-109	Outside Towel Mount	1
16	42-105	Top Strap	4
17	42-106	Bottom Strap	4
18	42-122	Rake Spring	12
19	42-129	Groomer Blades	3
20	42-107	Matting	4
21	15-013	Rubber Bumper	2
22	42-177	Spring Holder	12

42-130Q 84" (213CM) MILD STEEL TOURNAMENT RAKE DRAWING

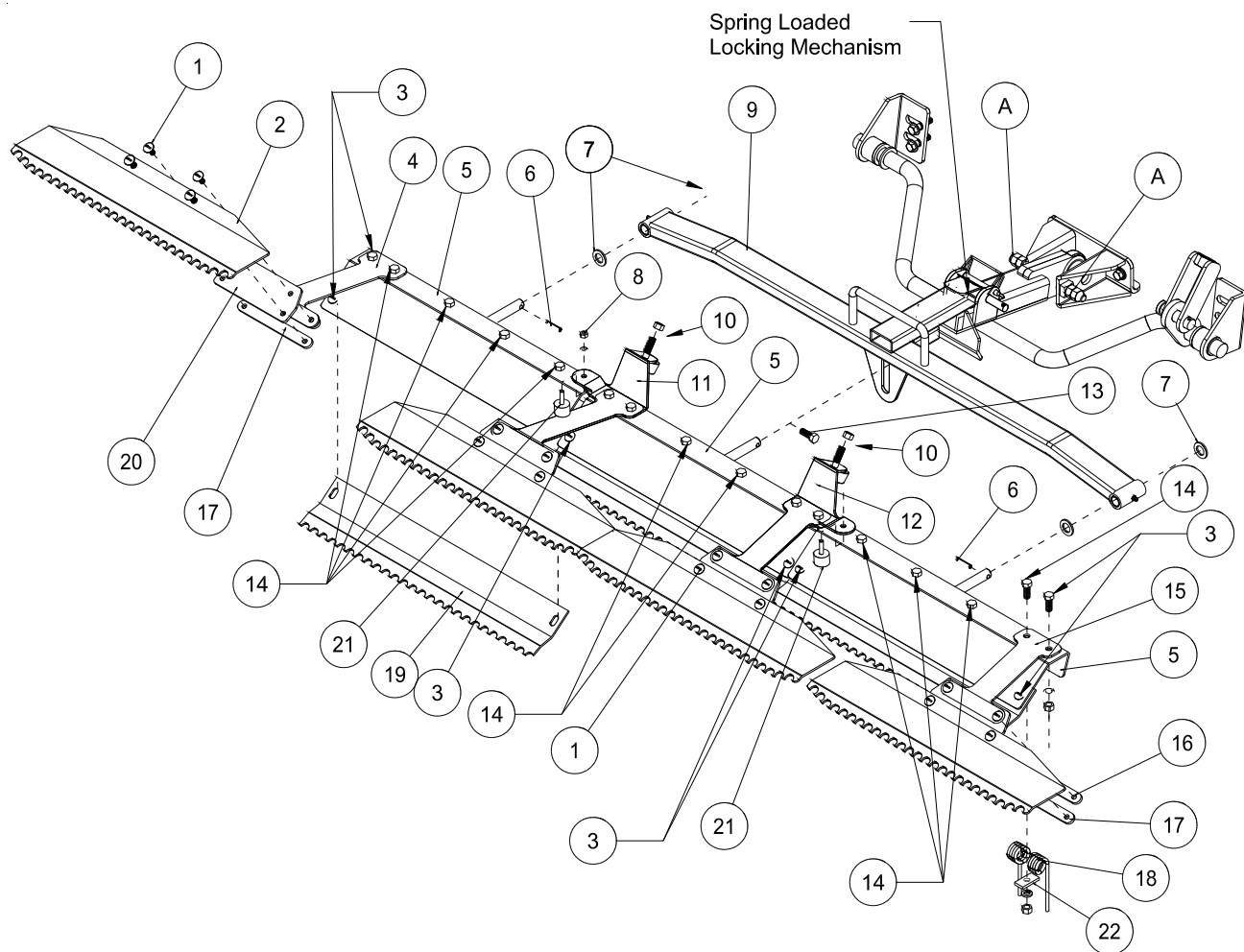

Rear Attachment

RAKE ASSEMBLY INSTRUCTIONS

1. Hex Bolt rake spring (Ref 18) to rake frames (Ref 5) using hardware (Ref 14). Leave the two outside holes on right, left, and center rake open.
 2. Attach rubber bumper (Ref 21) using cap nut and washer (Ref 8). Attach rubber grommet (Ref 10) to inside mounts (Ref 11 & 12)
 3. Attach the left outside mount (Ref 4), the left inside mount (Ref 11), the outside trowel mount (Ref 15), and the inside trowel mount (Ref 12) to the outside and center rakes (Ref 5) as shown. Use the $\frac{3}{4}$ " truss head screws (Ref 3) on the outside hole of each rake. Use the spring holder (Ref 22) and the $1\frac{1}{4}$ " truss head screws (Ref 14) to attach rake springs (Ref 18) to the rakes under the left outside and inside mounts and the outside and inside trowel mounts.
 4. Slide a machine bushing onto outside rake frames then slide the outside rake frames (Ref 5) into the tubing on the end of the drawbar. Hold in place with another machine bushing and a roll pin (Ref 6).
 5. Attach center rake (Ref 5) to draw bar (Ref 9) as shown, using $1\frac{3}{4}$ Hex Bolts and Nylon Lock Nuts (Ref 13) with the shaft of the center rake in the slot on the bottom of the drawbar.
 6. Attach the matting (Ref 20) and the top strap (Ref 16) to the inside and outside mounts using the truss head screw $\frac{5}{16}$ - 18 x 1 (Ref 1). Attach four finishing blades (Ref 2) to the matting on the inside and outside mounts with the truss head screw $\frac{5}{16}$ - 18 x 1 (Ref 1) going through the finishing blade, matting, and bottom strap (Ref 17).
 7. Place the three groomer blades (Ref 19) under the three rake assemblies as shown, using (Ref 3).
 8. Attach the rake lift to the trap rake quick hitch, by sliding the the hitch into the spring loaded locking mechanism.
 9. With the rake on the ground pull the rake to the right side until it is 2-3 inches from the tire.
 10. Using the adjustment Hex Bolts (Ref A) on the side of hitch, adjust the Hex Bolts until it hits the trap rake hitch. Lock jam nut so adjustment will not change.
 11. Repeat steps for the left side.
 12. Turn machine on and test for operation of rake assembly by raising and lowering the rake assembly. Also with rake down, turn sharp corners to check that rake does not touch wheels.
- NOTE:** Test rake in sand to assure tire tracks are covered by the rake when turning sharp corners in either direction. If there are tire tracks, readjust using the adjusting screws on the hitch, so the rake comes closer to the tire.

42-132Q 72"(183CM) MILD STEEL TOURNAMENT RAKE DRAWING

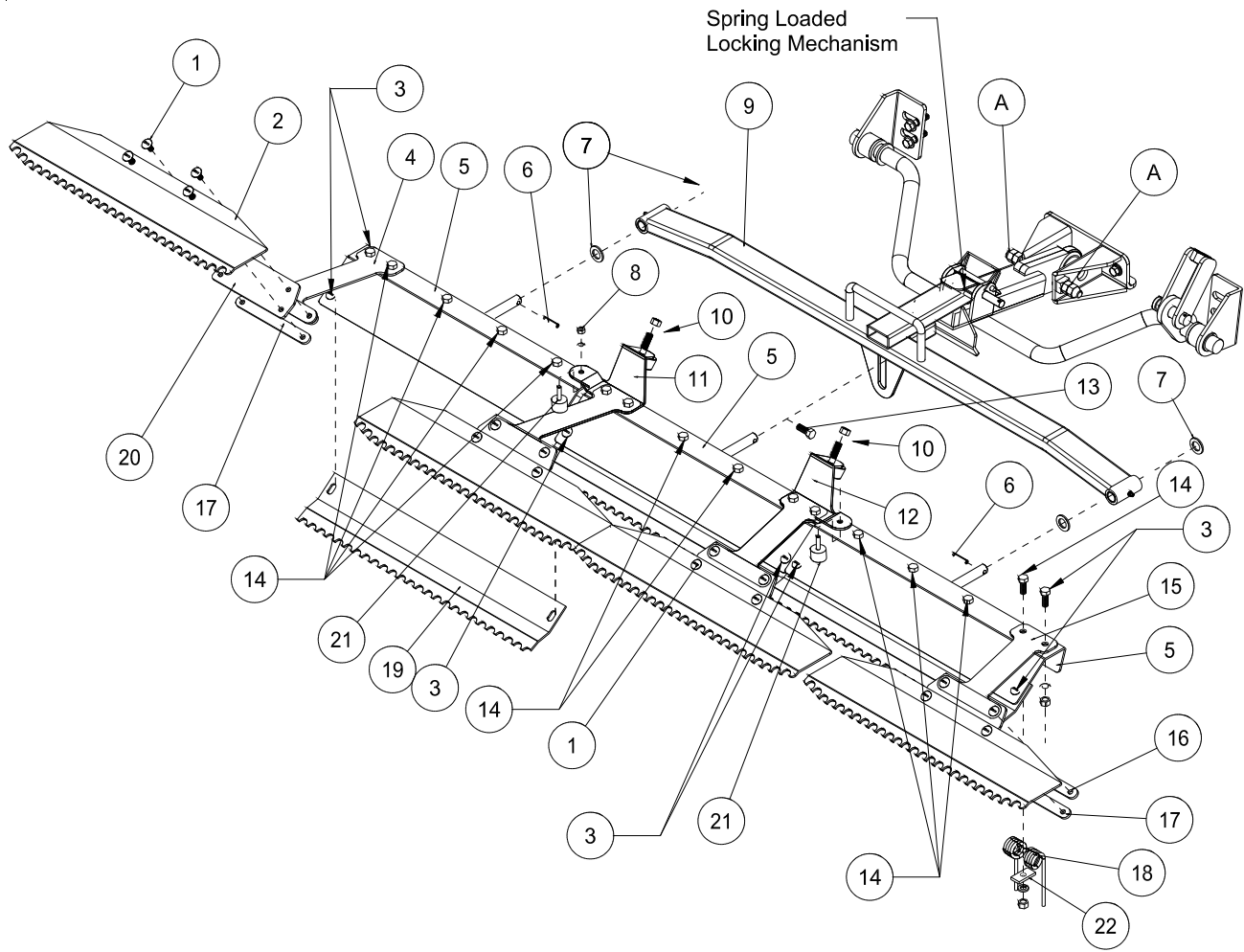

Rear Attachment

42-132Q 72"(183CM) MILD STEEL TOURNAMENT RAKE PARTS LIST

REF#	PART#	DESCRIPTION	QUANTITY
1	HSTP-516-18-100	Phillips Machine Screw, $\frac{5}{16}$ - 18 x 1	16
	HNFL-516-18	Flange Whiz-loc Nut, $\frac{5}{16}$ - 18	16
2	42-170	Finishing Blades	4
3	HSTP-516-18-075	Phillips Machine Screw, $\frac{5}{16}$ - 18 x $\frac{3}{4}$	10
	HNFL-516-18	Flange Whiz-loc Nut, $\frac{5}{16}$ - 18	10
4	42-111	Left Outside Mount	1
5	42-140	Outside Rake	3
6	HRP-14-100	Roll Pin, $\frac{1}{4}$ x 1	2
7	HMB-58-14	Machine Bushing, $\frac{5}{8}$ x 14GA	4
8	HNC-14-20	Cap Nut, $\frac{1}{4}$ - 20	2
	HWL-14	Lock Washer, $\frac{1}{4}$	2
9	43-154	Draw Bar	1
	20-018	Oilite Bushing (comes with 43-154)	4
10	50-081	Rubber Bumper	2
	HNFL-38-16	Flange Whiz-loc Nut, $\frac{3}{8}$ - 18	2
11	42-110	Left Inside Mount	1
12	42-108	Inside Trowel Mount	1
13	HB-14-20-175	Hex Bolt, $\frac{1}{4}$ - 20 x $1\frac{3}{4}$	1
	HNTL-14-20	Nylon Lock Nut, $\frac{1}{4}$ - 20	1
14	HSTP-516-18-125	Phillips Machine Screw, $\frac{5}{16}$ - 18 x $1\frac{1}{4}$	12
	HNFL-516-18	Flange Whiz-loc Nut, $\frac{5}{16}$ - 18	12
15	42-109	Outside Towel Mount	1
16	42-105	Top Strap	4
17	42-106	Bottom Strap	4
18	42-122	Rake Spring	12
19	42-171	Groomer Blades	3
20	42-107	Matting	4
21	15-013	Rubber Bumper	2
22	42-177	Spring Holder	12

RAKE ASSEMBLY INSTRUCTIONS

1. Hex Bolt rake spring (Ref 18) to rake frames (Ref 5) using hardware (Ref 14). Leave the two outside holes on right, left, and center rake open.
 2. Attach rubber bumper (Ref 21) using cap nut and washer (Ref 8). Attach rubber grommets (Ref 10) to inside mounts (Ref 11 & 12)
 3. Attach the left outside mount (Ref 4), the left inside mount (Ref 11), the outside trowel mount (Ref 15), and the inside trowel mount (Ref 12) to the outside and center rakes (Ref 5) as shown. Use the $\frac{3}{4}$ " truss head screws (Ref 3) on the outside hole of each rake. Use the spring holder (Ref 22) and the $1\frac{1}{4}$ " truss head screws (Ref 14) to attach rake springs (Ref 18) to the rakes under the left outside and inside mounts and the outside and inside trowel mounts.
 4. Slide a machine bushing onto outside rake frames then slide the outside rake frames (Ref 5) into the tubing on the end of the drawbar. Hold in place with another machine bushing and a roll pin (Ref 6).
 5. Attach center rake (Ref 5) to draw bar (Ref 9) as shown, using $1\frac{3}{4}$ Hex Bolts and Nylon Lock Nuts (Ref 13) with the shaft of the center rake in the slot on the bottom of the drawbar.
 6. Attach the matting (Ref 20) and the top strap (Ref 16) to the inside and outside mounts using the truss head screw $\frac{5}{16}$ - 18 x 1 (Ref 1). Attach four finishing blades (Ref 2) to the matting on the inside and outside mounts with the truss head screw $\frac{5}{16}$ - 18 x 1 (Ref 1) going through the finishing blade, matting, and bottom strap (Ref 17).
 7. Place the three groomer blades (Ref 19) under the three rake assemblies as shown, using (Ref 3).
 8. Attach the rake lift to the trap rake quick hitch, by sliding the the hitch into the spring loaded locking mechanism.
 9. With the rake on the ground pull the rake to the right side until it is 2-3 inches from the tire.
 10. Using the adjustment Hex Bolts (Ref A) on the side of hitch, adjust the Hex Bolts until it hits the trap rake hitch. Lock jam nut so adjustment will not change.
 11. Repeat steps for the left side.
 12. Turn machine on and test for operation of rake assembly by raising and lowering the rake assembly. Also with rake down, turn sharp corners to check that rake does not touch wheels.
- NOTE:** Test rake in sand to assure tire tracks are covered by the rake when turning sharp corners in either direction. If there are tire tracks, readjust using the adjusting screws on the hitch, so the rake comes closer to the tire.

13-758 MAX FLEX SAND RAKE

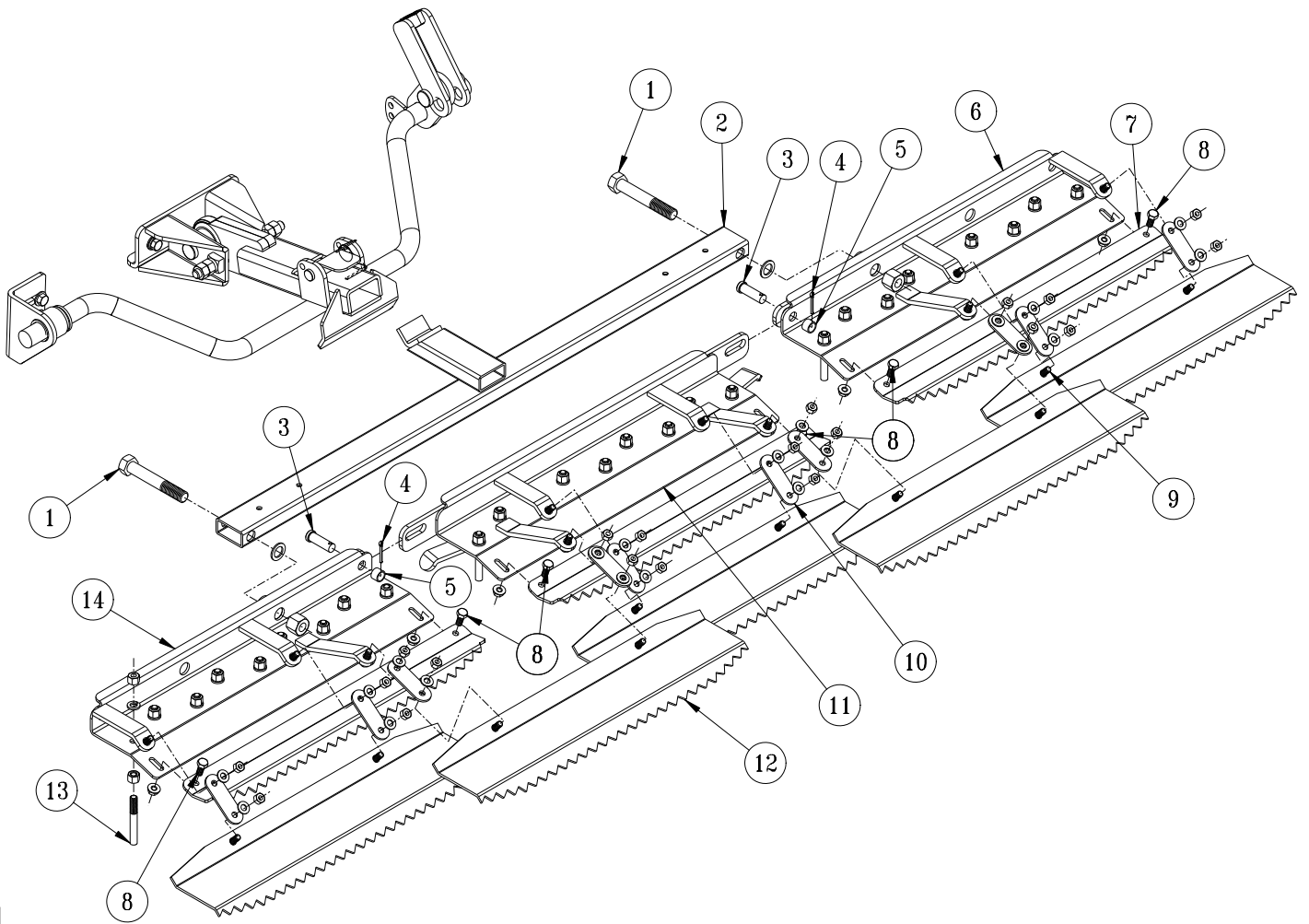

Rear Attachment

13-758 MAX FLEX SAND RAKE

REF#	PART#	DESCRIPTION	QUANTITY
1	HB-58-11-400	Hex Bolt, $\frac{5}{8}$ - 11 x 4	2
	HMB-58-14	Machine Bushing, $\frac{5}{8}$ x 14GA	2
	HNCL-58-11	Nylon Lock Nut, $\frac{5}{8}$ - 11	2
2	43-145	Draw bar	1
3	HCP-12-150	Clevis Pin, $\frac{1}{2}$ x $1\frac{1}{2}$	2
4	HP-18-100	Cotter Pin, $\frac{1}{8}$ x 1	2
5	76-275	Spacer	2
6	13-762	Right Rake	1
7	13-759	Grooming Blade	3
8	HB-516-18-075	Hex Bolt, $\frac{5}{16}$ - 18 x $\frac{3}{4}$	6
	HNFL-516-18	Flange Whiz-loc Nut, $\frac{5}{16}$ - 18	6
9	HBFL-516-18-100	Flange Lock Hex Bolt, $\frac{5}{16}$ - 18 x 1	20
	HNTL-516-18	Nylon Nylon Lock Nut, $\frac{5}{16}$ - 18	20
	HW-516	Flat Washer, $\frac{5}{16}$	20
10	13-757	Rake Connect Strap	10
11	13-761	QH Center Rake	1
12	13-443	Finishing Blade	5
14	13-763	Left Rake	1
13*	13-445	Rake Teeth Kit (27 Studs and Hardware)	1

INSTALLATION INSTRUCTIONS

- Hex Bolt rake teeth (Ref 13) to frames, keeping all the same length.
- Lay out rake frames (Refs 6, 11 & 14). Connect them using Clevis Pin (Ref 3), Spacer (Ref 5) and Cotter Pin (Ref 4).
- Attach Left Frame (Ref 14) and Right Frame (Ref 6) to Draw bar (Ref 2) using $\frac{5}{8}$ Hex Bolt, Machine Bushing, and Center Nylon Lock Nut (Ref 1).
- Attach the three Groomer Blades (Ref 7), one to each of the Rake Frames (Refs 6, 11 & 14) using two Hex Bolts and Flange Whiz-loc Nuts (Ref 8). Slide Groomer Blades to end of slot and tighten hardware.
- Attach the five Finishing Blades (Ref 12) to the tabs of the rake frames using two Rake Connect Strap (Ref 10) per Finishing blade. Secure using Flange Lock Hex Bolt, Flat Washer and Nylon Nylon Lock Nut (Ref 9).

NOTE: Attach Straps using hardware as illustrated, placing Flat Washer on Strap then secure with Nylon Lock Nut. Attaching with the Flange Hex Bolt in contact with the Strap will cause the Strap to bind and misalign Finishing Blade.

- Attach the rake to the trap rake quick hitch by sliding the draw bar hitch into the spring loaded locking mechanism.
- With the rake on the ground pull the rake to the right side until it is 2-3 inches from the tire.
- Repeat steps on left side.
- Turn machine on and test for operation of rake assembly by raising and lowering the rake assembly. Also with rake down, turn sharp corners to check that rake does not touch wheels.
- NOTE:** Test rake in sand to assure tire tracks are covered by the rake when turning sharp corners in either direction. If there are tire tracks, readjust using the adjusting screws on the hitch, so the rake comes closer to the tire.

45-503 84" RAKE ASSEMBLY DRAWING

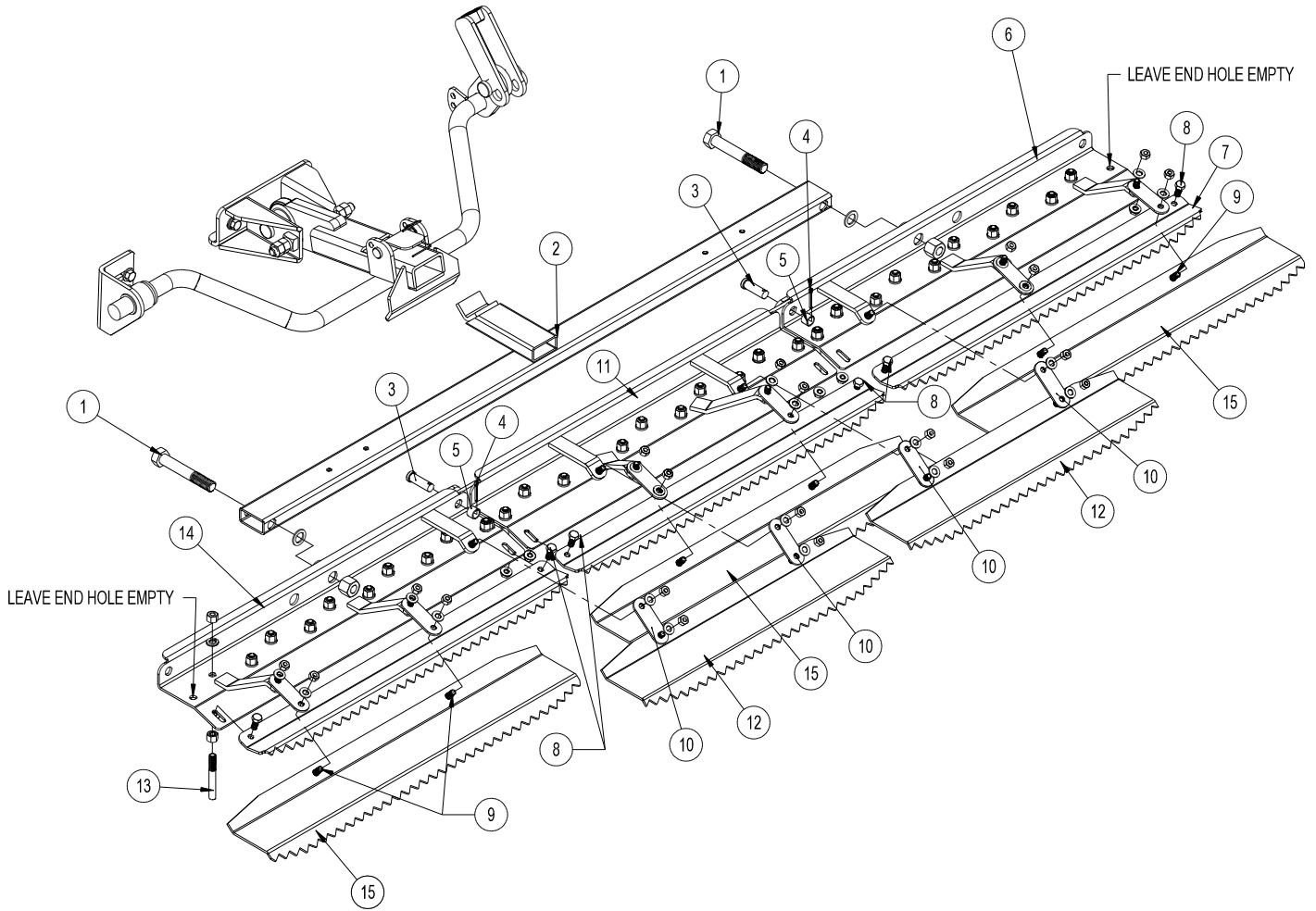

Rear Attachment

45-503 84" RAKE ASSEMBLY PARTS LIST

REF#	PART#	DESCRIPTION	QUANTITY
1*	HB-58-11-400	Hex Bolt, $\frac{5}{8}$ - 11 x 4	2
	HMB-58-14	Machine Bushing, $\frac{5}{8}$ x 14GA	2
	HNCL-58-11	Nylon Lock Nut, $\frac{5}{8}$ - 11	2
2	45-588	Drawbar	1
3*	HCP-12-150	Clevis Pin, $\frac{1}{2}$ x $1\frac{1}{2}$	2
4*	HP-18-100	Cotter Pin, $\frac{1}{8}$ x 1	2
5	76-275	Spacer	2
6	45-590	Right Rake Frame	1
7	45-586	Grooming Blade	3
8*	HB-516-18-075	Hex Bolt, $\frac{5}{16}$ - 18 x $\frac{3}{4}$	6
	HNFL-516-18	Flange Whiz-loc Nut, $\frac{5}{16}$ - 18	6
9*	HBFL-516-18-075	Flange Whiz-loc Bolt, $\frac{5}{16}$ - 18 x $\frac{3}{4}$	20
	HNTL-516-18	Nylon Lock Nut, $\frac{5}{16}$ - 18	20
	HW-516	Flat Washer, $\frac{5}{16}$	20
10	13-757	Rake Connect Strap	10
11	45-589	Center Rake Frame	1
12	13-443	Finishing Blade	2
13	19-106	Rake Teeth	31
	HN-38-16	Hex Nut, $\frac{3}{8}$ -16	62
	HWL-38	Lock Washer, $\frac{3}{8}$	31
14	45-591	Left Rake Frame	1
15	45-587	Finishing Blades	3
*	13-764	Hardware Kit	1

INSTALLATION INSTRUCTIONS

- Hex Bolt rake teeth (Ref 13) to frames, keeping all the same length.
- Lay out rake frames (Refs 6, 11 & 14). Connect them using clevis pin (Ref 3), Spacer (Ref 5) and cotter pin (Ref 4).
- Attach left frame (Ref 14) and right frame (Ref 6) to draw bar (Ref 2) using $\frac{5}{8}$ Hex Bolt, machine bushing, and center Nylon Lock Nut (Ref 1).
- Attach the three groomer blades (Ref 7), one to each of the rake frames (Refs 6, 11 & 14) using two Hex Bolts and Flange Whiz-loc Nuts (Ref 8). Slide groomer blades to end of slot and tighten hardware.
- Attach three large finishing blades (Ref 15) and then the two smaller finishing blades (Ref 12) to the tabs of the rake frames using two rake connect strap (Ref 10) per finishing blade. Secure, using flange lock Hex Bolt, flat washer and nylon Nylon Lock Nut (Ref 9).

NOTE: Attach Straps using hardware as illustrated, placing Flat Washer on Strap then secure with Nylon Lock Nut. Attaching with the Flange Hex Bolt in contact with the Strap will cause the Strap to bind and misalign Finishing Blade.

- Attach the rake to the trap rake quick hitch by sliding the draw bar hitch into the spring loaded locking mechanism.
- With the rake on the ground pull the rake to the right side until it is 2-3 inches from the tire.
- Repeat steps on left side.
- Turn machine on and test for operation of rake assembly by raising and lowering the rake assembly. Also with rake down, turn sharp corners to check that rake does not touch wheels.
- NOTE:** Test rake in sand to assure tire tracks are covered by the rake when turning sharp corners in either direction. If there are tire tracks, readjust using the adjusting screws on the hitch, so the rake comes closer to the tire.

45-511 RUBBER FLEX RAKE ASSEMBLY DRAWING

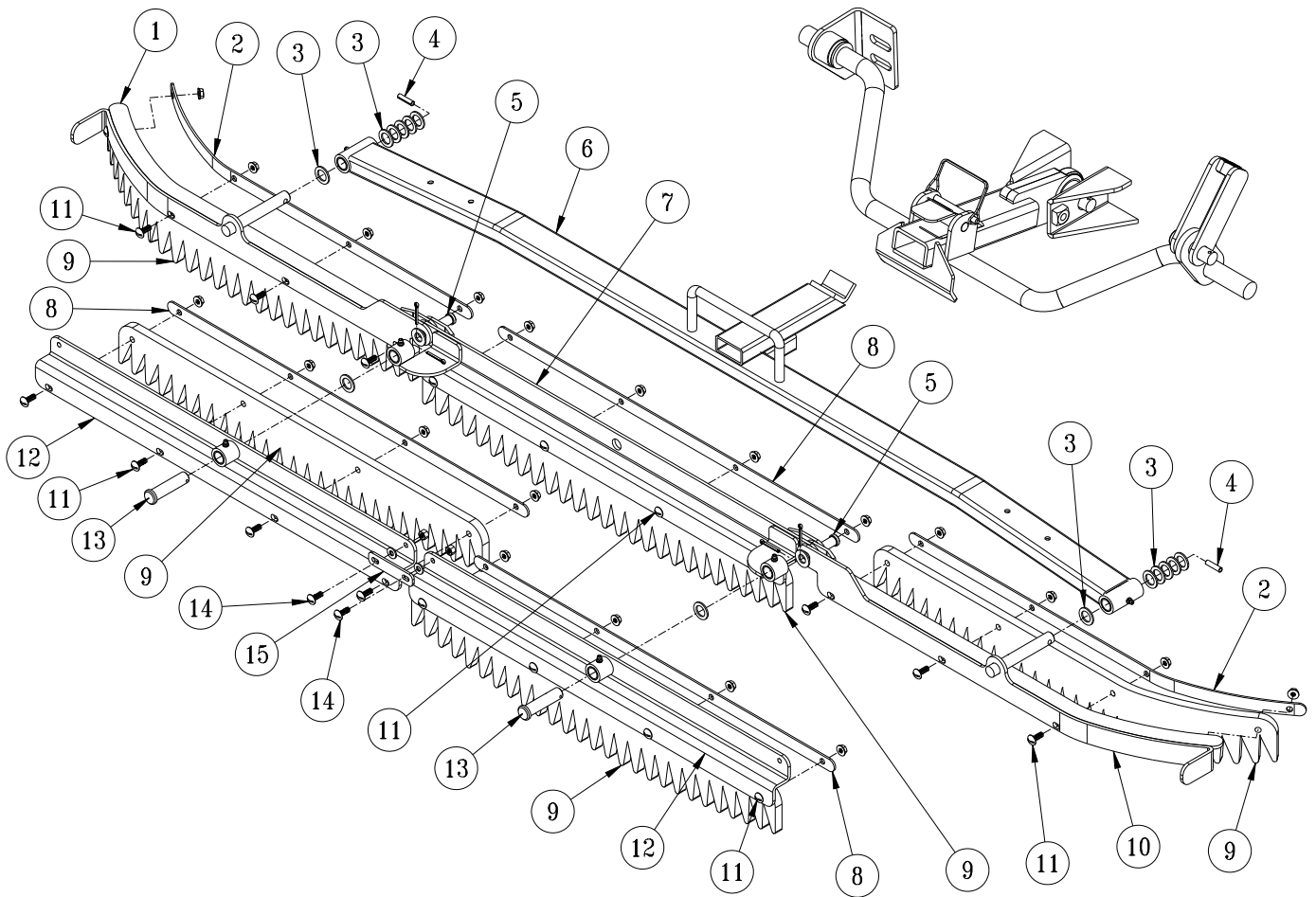

Rear Attachment

45-511 RUBBER FLEX RAKE ASSEMBLY PARTS LIST

REF#	PART#	DESCRIPTION	QUANTITY
1	45-653	LH Wing	1
2	45-657	Curved Cover Strap	2
3	HMB-58-14	Machine Bushing, $\frac{5}{8}$ x 14GA	12
4	HRP-14-100	Roll Pin, $\frac{1}{4}$ x 1	2
5	HCP-12-150	Clevis Pin, $\frac{1}{2}$ - $1\frac{1}{2}$	2
	HMB-12-14	Machine Bushing, $\frac{1}{2}$ x 14GA	2
	HP-18-100	Cotter Pin, $\frac{1}{8}$ x 1	2
6	45-649	Draw bar	1
7	45-654	Center Rake	1
8	45-658	Flat Cover Strap	1
9	45-651	Rubber Rake Blade	5
10	45-652	RH Wing	1
11	HSTP-14-20-100	Phillips Machine Screw, $\frac{1}{4}$ - 20 x 1	20
	HNFL-14-20	Flange Whiz-loc Nut, $\frac{1}{4}$ - 20	20
12	45-655	Rear Rake Mount	2
13	HCP-58-250	Clevis Pin, $\frac{5}{8}$ x $2\frac{1}{2}$	2
	HMB-58-14	Machine Bushing, $\frac{5}{8}$ x 14GA	2
	HP-18-100	Cotter Pin, $\frac{1}{8}$ x 1	2
14	HSTP-14-20-075	Phillips Machine Screw, $\frac{1}{4}$ - 20 x $\frac{3}{4}$	2
	HNTL-14-20	Nylon Nylon Lock Nut, $\frac{1}{4}$ - 20	2
	HW-14	Flat Washer, $\frac{1}{4}$	2
15	45-656	Rake Strap	1

INSTALLATION INSTRUCTIONS

1. Hex Bolt rubber rake blades (Ref 9) onto all five rake sections using $\frac{1}{4}$ x 1 machine Hex Bolts, and Flange Whiz-loc Nuts (Ref 11). Add cover straps (Ref 8) and then tighten hardware.
2. Lay out right, left and center rake sections and connect them using $\frac{1}{2}$ x $1\frac{1}{2}$ clevis pins, machine bushings, and cotter pins (Ref 5).
3. Attach the three assembled sections onto the draw bar (Ref 6) and secure with machine bushings and roll pins (Ref 3 and 4).
4. Connect the two rear rake mounts (Ref 12) together with the rake strap (Ref 8) using two $\frac{1}{4}$ x $\frac{3}{4}$ machine Hex Bolts with nylon Nylon Lock Nuts (Ref 14). **Only tighten enough so they move freely.**
5. Connect the two assembled rear rake mounts onto the other rake sections using two $\frac{5}{8}$ x $2\frac{1}{2}$ clevis pins, machine bushings and cotter pins (Ref 13).
6. Attach the rake to the bunker rake quick hitch by sliding the draw bar into the spring loaded locking mechanism.
7. With the rake on the ground, pull the rake to the sides and adjust hitch stops so the rake stops about 2" from the tires.
8. Start machine and test for operation of rake assembly by raising and lowering the rake assembly. Check for loose hardware.

13-740 SAND RAKE BRUSH KIT DRAWING

For use with 42-130

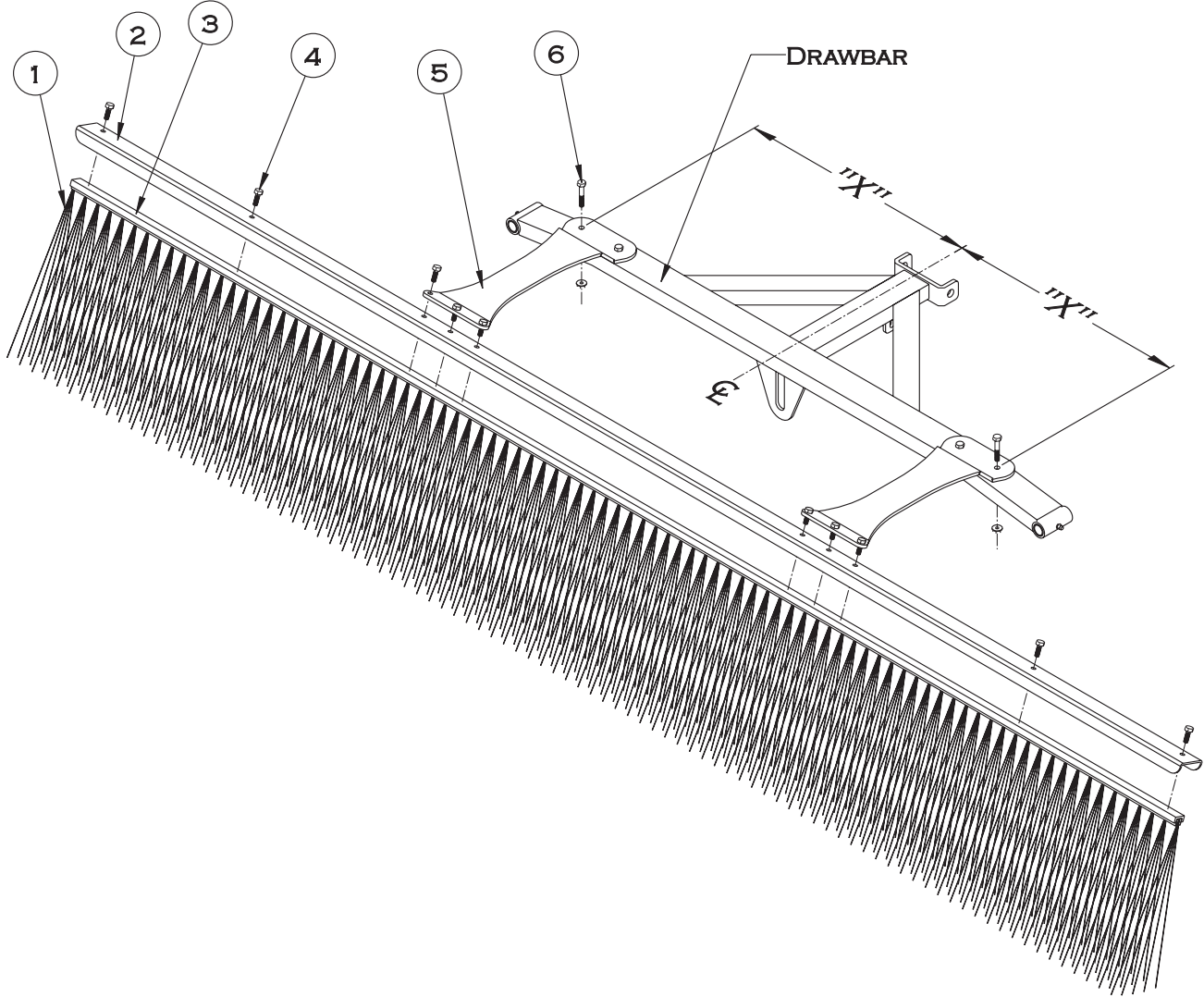

Rear Attachment

13-740 SAND RAKE BRUSH KIT PARTS LIST

REF#	PART#	DESCRIPTION	QUANTITY
1	13-738	Brush, 89 x 11	1
2	13-737	Brush Channel	1
3	13-739	Brush Track	1
4	HB-14-20-075	Hex Bolt, $\frac{1}{4}$ - 20 x $\frac{3}{4}$	10
	HNFL-14-20	Flange Whiz-loc Nut, $\frac{1}{4}$ - 20	10
5	13-681	Mounting Brackets	2
6	HB-14-20-150	Hex Bolt, $\frac{1}{4}$ - 20 x $1\frac{1}{2}$	4
	HNFL-14-20	Flange Whiz-loc Nuts, $\frac{1}{4}$ - 20	4

INSTALLATION INSTRUCTIONS

1. Place the Brush (Ref 1) into the Brush Track (Ref 3). Place the Brush Channel (Ref 2) between the brush track and the mounting brackets. Now Hex Bolt the Mounting Brackets (Ref 5) to the brush track using the $\frac{3}{4}$ " Hex Bolts and Flange Whiz-loc Nuts(Ref 4).
2. To mount the Brush Assembly (Refs 1-5) to the Rake Draw bar, first align the Mounting Brackets so the Brush Assembly is centered ("X" measurements are equal) on the Rake Draw bar. Mark the locations for the four holes that will need to be drilled. Note: To fit the curve of the Rake Draw bar, a small amount of twist will need to be put in the Mounting Brackets. This can be done by clamping the Mounting Brackets to the Draw bar.
3. Mount the Brush Assembly to the Rake Draw bar using the four $1\frac{1}{2}$ " Hex Bolts and Flange Whiz-loc Nuts(Ref 6).

13-684 SAND RAKE BRUSH KIT DRAWING

For use with 13-438

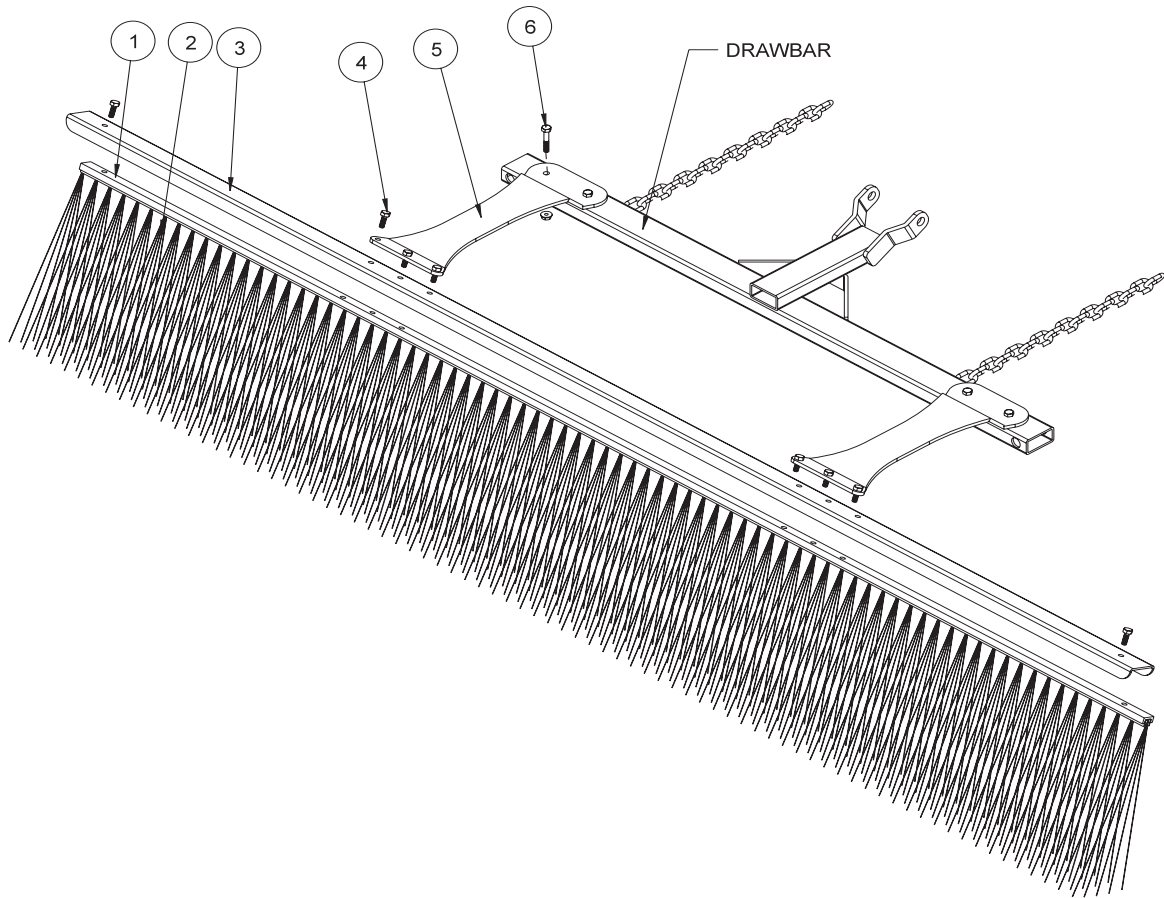

HOLE LOCATION

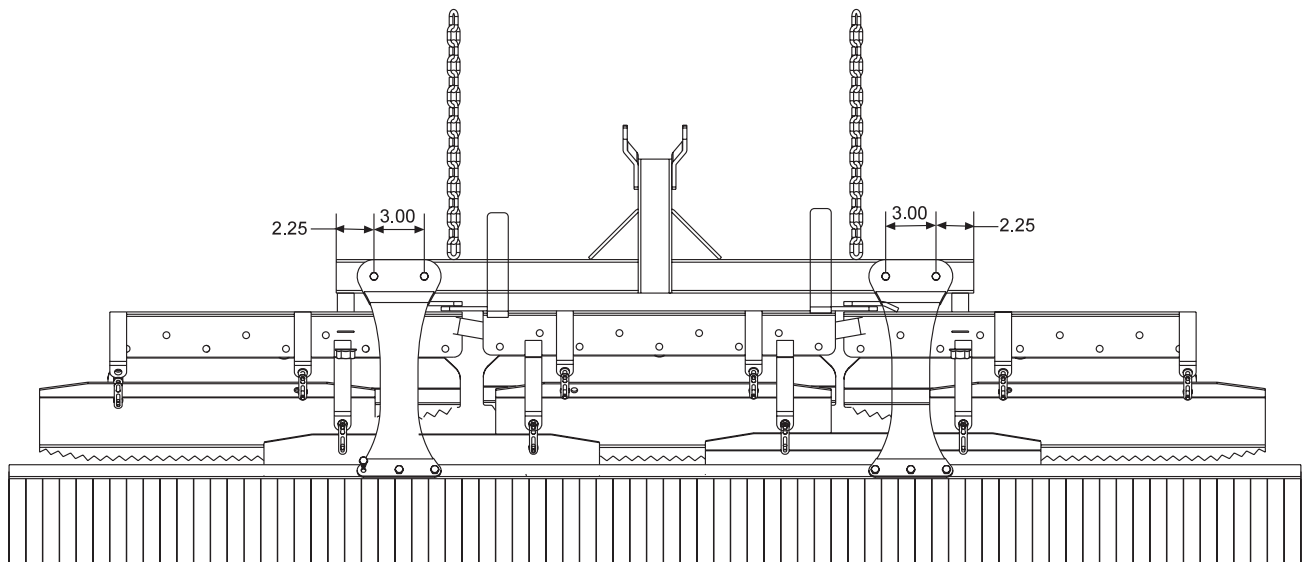

Rear Attachment

13-684 SAND RAKE BRUSH KIT PARTS LIST

REF#	PART#	DESCRIPTION	QUANTITY
1	13-683	Brush Track	1
2	13-682	Brush, 77 x 11	1
3	13-688	Brush Channel	1
4	HB-14-20-075	Hex Bolt, $\frac{1}{4}$ - 20 x $\frac{3}{4}$	8
	HNFL-14-20	Flange Whiz-loc Nut, $\frac{1}{4}$ - 20	8
5	13-681	Mounting Brackets	2
6	HB-14-20-150	Hex Bolt $\frac{1}{4}$ - 20 x $1\frac{1}{2}$	4
	HNFL-14-20	Flange Whiz-loc Nuts, $\frac{1}{4}$ - 20	4

INSTALLATION INSTRUCTIONS

1. Place the brush (Ref 2) into the brush track (Ref 1). Place the brush channel (Ref 3) between the brush track and the mounting brackets. Now Hex Bolt the mounting brackets (Ref 5) to the brush track using the $\frac{3}{4}$ " Hex Bolts and Flange Whiz-loc Nuts (Ref 3).
2. Two holes need to be drilled into the draw bar of the rake to install the brush. Drill two .281 holes $2\frac{1}{4}$ " in from each end and 3" apart (see drawing).
3. Mount the brush assembly to the draw bar using four $\frac{3}{4}$ " Hex Bolts and Flange Whiz-loc Nuts (Ref 5).

13-298Q FAN RAKE ATTACHMENT DRAWING

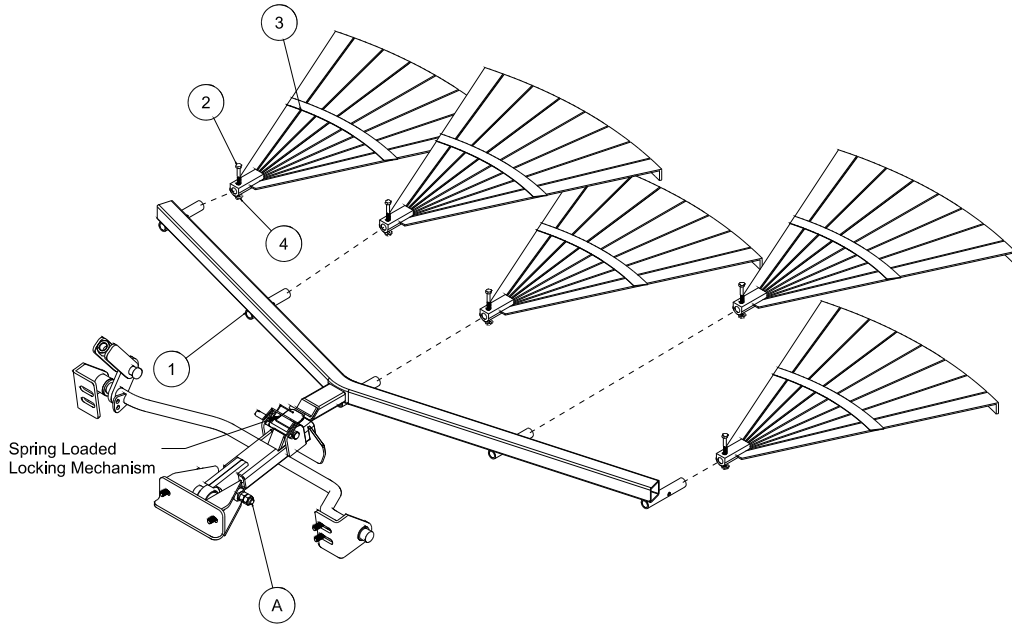

13-319-K FAN RAKE KIT DRAWING

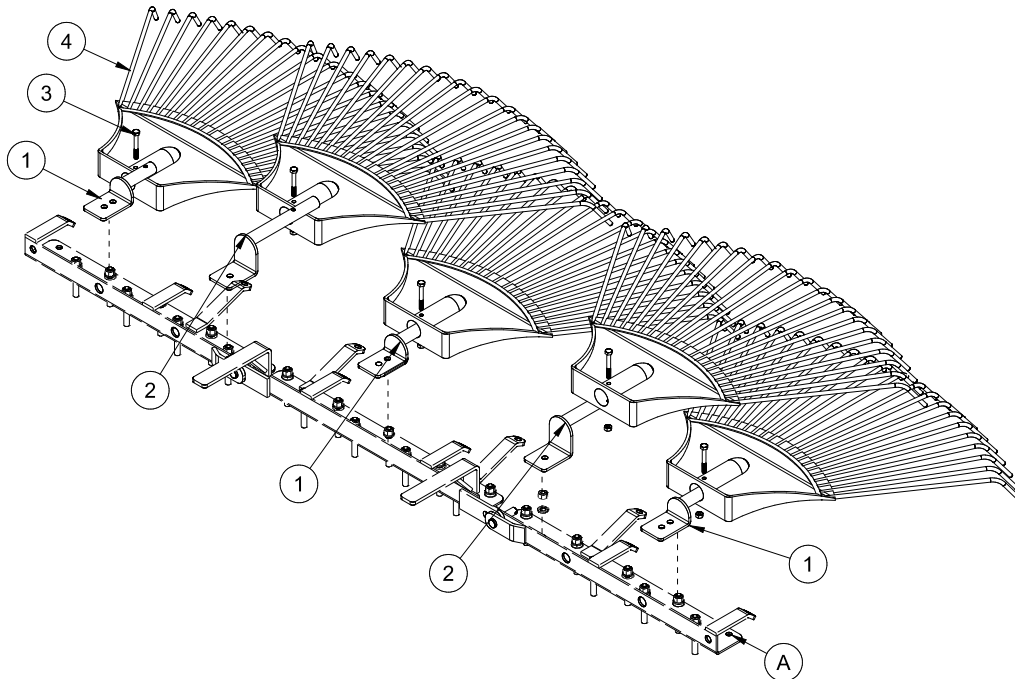

Rear Attachment

13-298Q FAN RAKE ATTACHMENT PARTS LIST

REF#	PART#	DESCRIPTION	QUANTITY
1	43-153	Frame	1
2	HB-14-20-200	Hex Bolt, 1/4 - 20 x 2	5
3	13-310	Rake	5
4	HNCL-14-20	Center Nylon Lock Nut, 1/4 - 20	5

INSTALLATION INSTRUCTIONS

1. Assemble the five rakes (Ref 3) to the frame using the Hex Bolt and center Nylon Lock Nuts (Ref 2 and 4). Slide the fan rake assembly under the rear of the trap rake to the hitch.
2. Attach the rake lift to the trap rake quick hitch, by sliding the hitch into the spring loaded locking mechanism.
3. With the rake on the ground pull the rake to the right side until it is 2-3 inches from the tire.
4. Repeat steps on left side.
5. Turn machine on and test for operation of rake assembly by raising and lowering the rake assembly. Also with rake down, turn sharp corners to check that rake does not touch wheels.

13-319-K FAN RAKE KIT PARTS LIST

REF#	PART#	DESCRIPTION	QUANTITY
1	13-327	Holder, Universal	3
2	13-329	Long Holder	2
3	HB-14-20-200	Hex Bolt, 1/4 - 20 x 2	5
	HNTL-14-20	Nylon Lock Nut, 1/4 - 20	5
4	13-310	Fan Rake	5

A No studs in first slot - Leave Empty.

FAN RAKE KIT INSTRUCTIONS

1. Assemble the fan rakes (Ref 4) to the frame using the bolt, and lock nuts(Ref 3). Slide the fan rake assembly under the rear of the trap rake to the hitch.
2. Attach the fan rake assemblies to the top of the frame. Use the nuts and washers that are on the studs to secure in place. The outside assemblies go in the third hole from the end.
3. Turn machine on and test for operation of rake assembly by raising and lowering the rake assembly. Also, with rake down, turn sharp corners to check that rake does not touch the wheels.

Rear Attachment

26-007Q PROFESSIONAL INFIELD FINISHER DRAWING

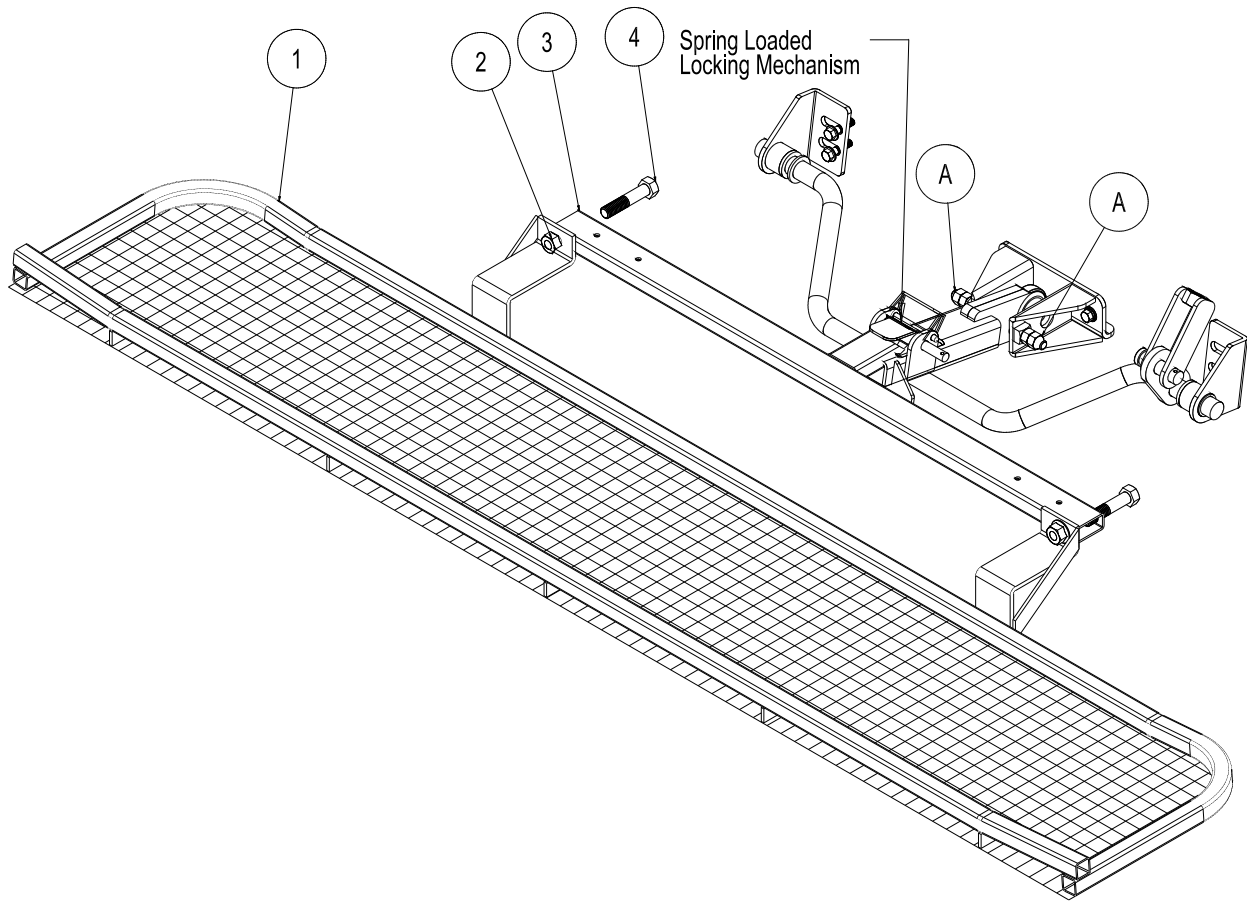

REF#	PART#	DESCRIPTION	QUANTITY
1	26-045	Leveling Screen	1
2	HNCL-58-11	Center Nylon Lock Nut, $\frac{5}{8}$ - 11	2
3	43-145	Draw bar	1
4	HB-58-11-300	Hex Bolt, $\frac{5}{8}$ - 11 x 3	2

INSTALLATION INSTRUCTIONS

The Professional Field Finisher is used for smoothing and leveling fields to professional standards.

1. Attach leveling screen (Ref 1) to draw bar (Ref 3) using two Hex Bolts (Ref 4) and center Nylon Lock Nuts (Ref 2).
2. Mount Professional Field Finisher to the hitch on the trap rake by sliding the draw bar into the quick hitch locking mechanism.
3. When Professional Field Finisher is attached, adjust Hex Bolts on hitch (Ref A) to hold Finisher in desired position.
4. **NOTE:** When assembled properly, rake will angle down from front to back. If front of finisher is not higher than the back, damage will result to infield.
5. When removing the attachment from machine. Push down on quick hitch locking mechanism and pull accessory out.

43-002Q FLEX ACTION FIELD FINISHER WITH BRUSH PARTS LIST

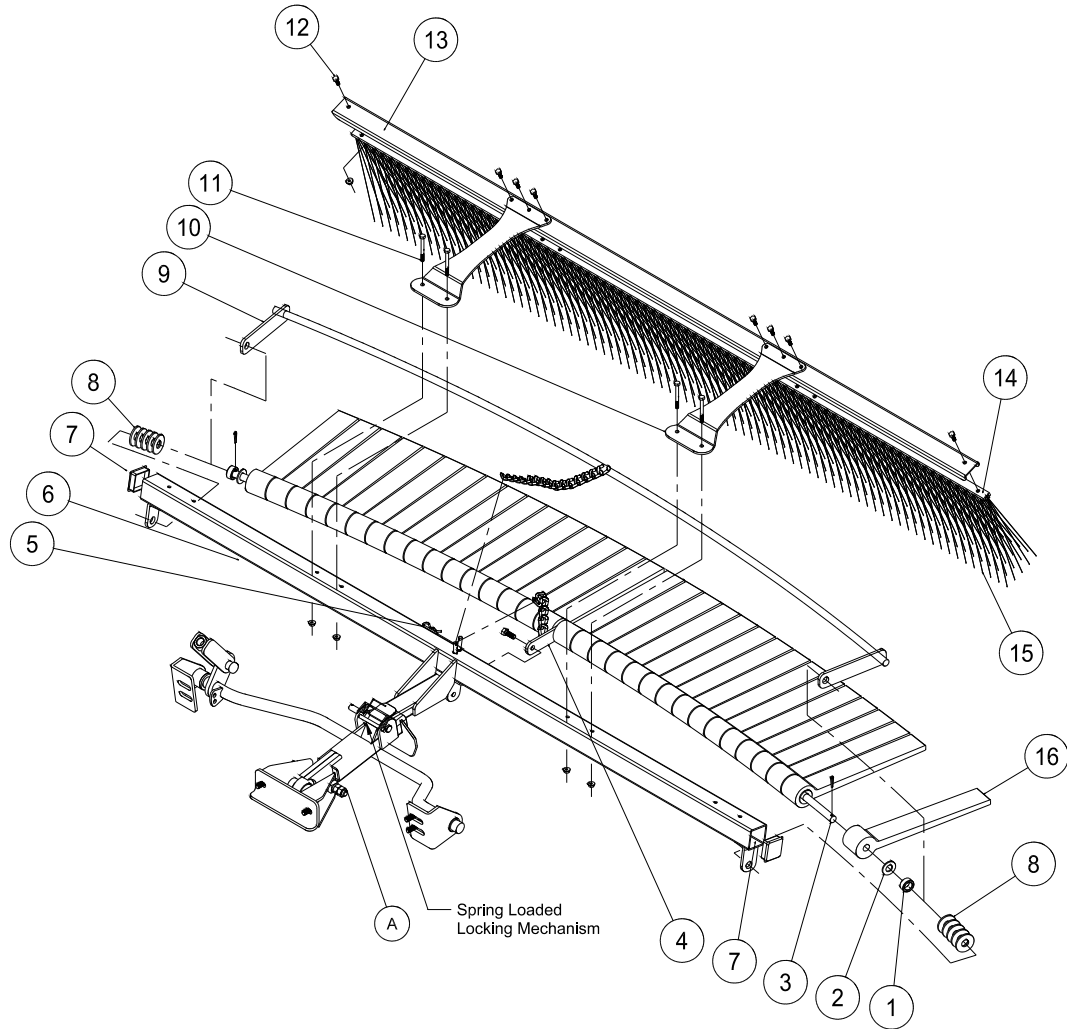

REF#	PART#	DESCRIPTION	QUANTITY
1	11-040	Spacer, $\frac{3}{4}$ "	2
2	HW-58	Washer, $\frac{5}{8}$	32
3	26-049	Mounting Bar	1
	HP-18-100	Cotter Pin, $\frac{1}{8}$ x 1	2
4	26-048	Flail Bar Strap	1
	HB-38-16-100	Hex Bolt, $\frac{3}{8}$ -16 x 1	1
	HNCL-38-16	Center Nylon Lock Nut, $\frac{3}{8}$ -16	1
5	HHP-18	Bridge Pin, $\frac{1}{8}$	2
6	43-146	Frame	1
7	18-297	Cap Plug	2
8	HMB-58-14	Machine Bushing, $\frac{5}{8}$ x 14GA	10
9	26-047	Leveler Bar	1
10	13-681	Mount Bracket	2
11	HB-14-20-250	Hex Bolt, $\frac{1}{4}$ -20 x $2\frac{1}{2}$	4
	HNFL-14-20	Flange Whiz-loc Nut, $\frac{1}{4}$ -20	4
12	HB-14-20-075	Hex Bolt, $\frac{1}{4}$ -20 x $\frac{3}{4}$	8
	HNFL-14-20	Flange Whiz-loc Nut, $\frac{1}{4}$ -20	8
13	13-688	Brush Channel	1
14	13-683	Brush Track	1
15	13-682	Brush, 77 x 11	1
16	26-041	Rasp Flail	32

Rear Attachment

43-002 Q FLEX ACTION FIELD FINISHER WITH BRUSH DRAWING

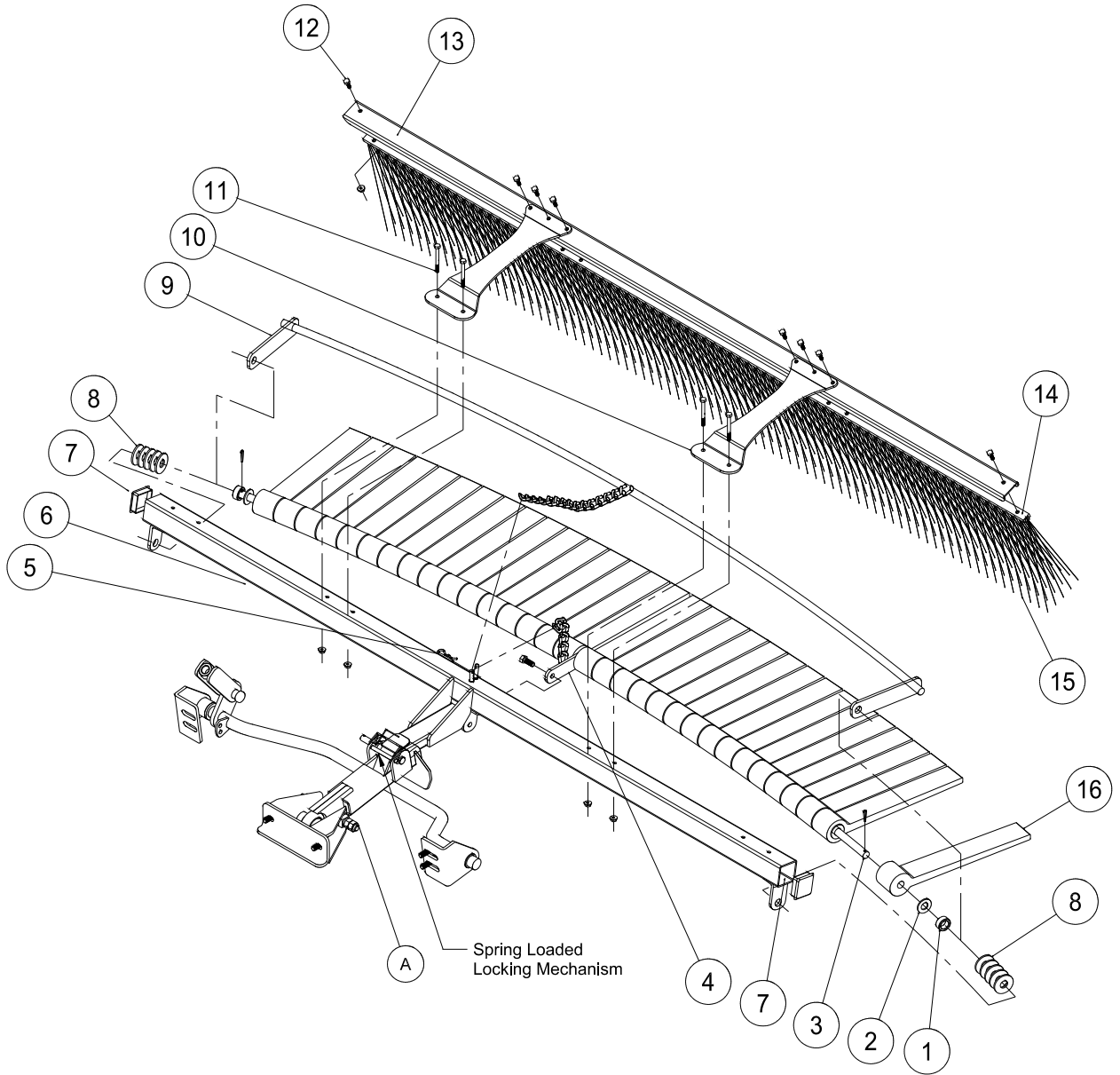

Rear Attachment

43-002Q FLEX ACTION FIELD FINISHER WITH BRUSH INSTRUCTIONS

ASSEMBLY INSTRUCTIONS

1. Install flail bar strap (Ref 4) to center of mounting bar (Ref 3) with chain on top of flail bar strap and mounting bar bent away from you. Apply a light coat of lubricant to overall length of mounting bar.
2. Install one rasp flail (Ref 16) with knobby side down adjacent to sides of flail bar strap. Now install a flat washer (Ref 2) so it sits adjacent with the outside of the rasp flail. Continue to install flails with knobby sides down with washers between until you have 16 flails and washers on each side of bar strap. Force all flails tightly toward bar strap.
3. After all 32 flails have been installed, place one spacer (Ref 1) to each end of mounting bar adjacent to washer.
4. Install leveler bar (Ref 9) to mounting bar, with curved leveler bar resting on top on the smooth sides of flails. If all flails and washers do not fit snugly at this time, remove leveler bar and install enough machine bushings to ensure a snug fit. Then reinstall leveler bar.
5. Lay the frame (Ref 6) on the floor or bench with welded tabs facing up. Install ends of assembled mounting bar, with knobby sides of flails up, into welded tabs on each end of frame and secure with $\frac{1}{8}$ x 1 cotter pin.
6. Install flail bar strap (Ref 4) to center tab on frame with $\frac{3}{8}$ -16 x 1 Hex Bolt and $\frac{3}{8}$ -16 center Nylon Lock Nut. Loose fit is required. Do not over tighten.
7. Flip assembly over so knobby sides of flails are now facing down. Install hitch to frame with clevis pin (Ref 3) and cotter pin (Ref 24). The hitch should be attached to the frame as shown.
8. Install bar strap chain over welded pin on frame. Install leveler bar chain on to pin and secure in place with bridge pin. Use last bridge pin and clevis pin to hitch field finisher to your machine.

OPERATING INSTRUCTIONS

Running attachment with all flails down, flat on the surface, will provide a leveling function. Running attachment partially raised and flails at a 20° - 40° angle in relation to the level surface, will provide a finishing function. The flails increase down pressure for desired finish. Drive in wide circular patterns and increase or decrease ground speed to achieve desired finish.

BRUSH ASSEMBLY

1. Place the brush (Ref 15) into the brush track (Ref 14). Place the brush channel (Ref 13) between the brush track and the mounting brackets. Now Hex Bolt the mounting brackets (Ref 10) to the brush track using the $\frac{1}{4}$ -20 x $\frac{3}{4}$ Hex Bolts and $\frac{1}{4}$ -20 Flange Whiz-loc Nuts (Ref 12).
2. Mount the brush assembly to the frame using the (4) $\frac{1}{4}$ -20 x 2 $\frac{1}{2}$ Hex Bolts and $\frac{1}{4}$ -20 Flange Whiz-loc Nuts (Ref 11).

26-008Q FLEX ACTION FIELD FINISHER DRAWING

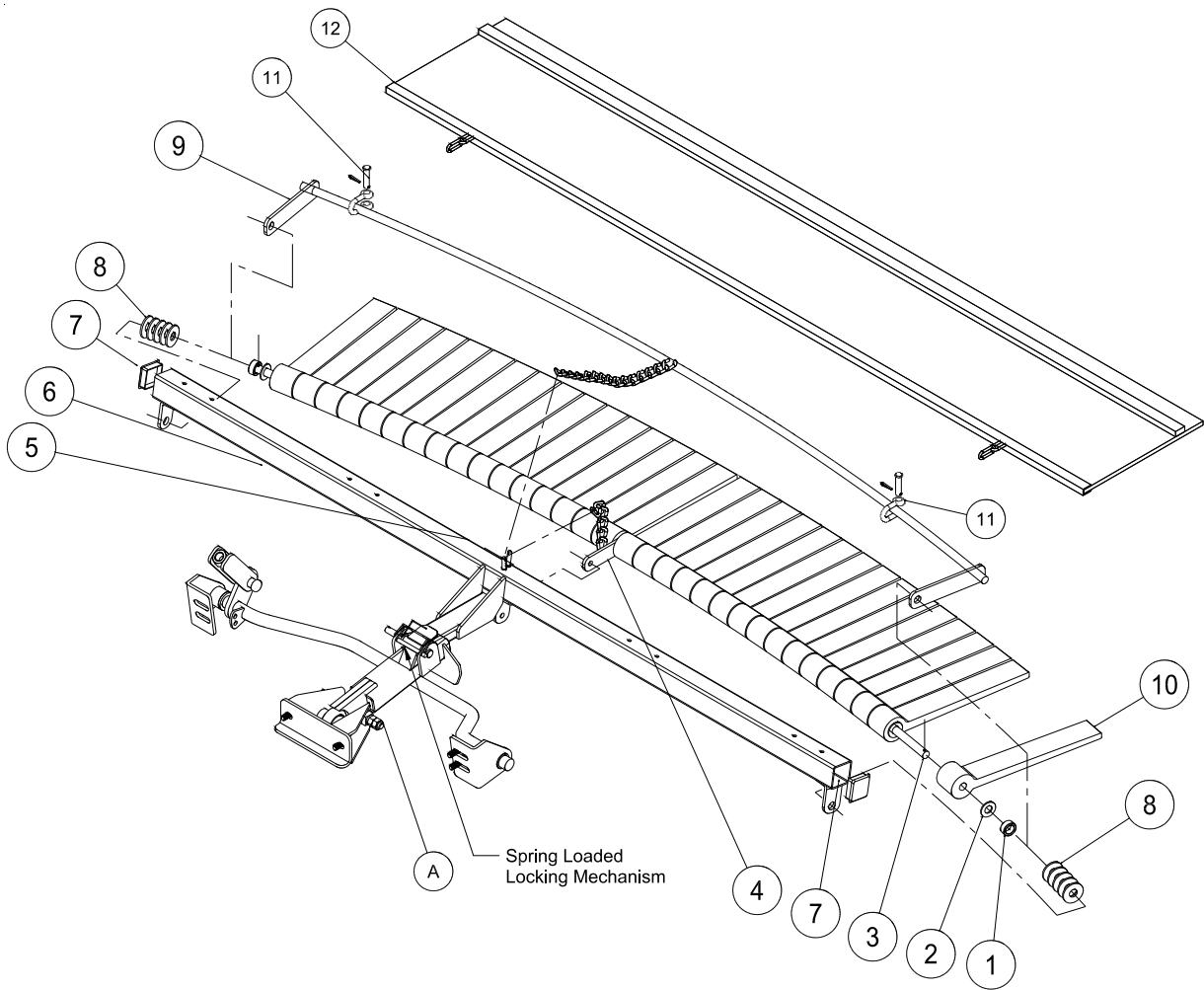

Rear Attachment

26-008Q FLEX ACTION FIELD FINISHER PARTS LIST

REF#	PART#	DESCRIPTION	QUANTITY
1	11-040	Spacer, $\frac{3}{4}$ "	2
2	HW-58	Flat Washer, $\frac{5}{8}$	32
3	26-049	Mounting Bar	1
4	26-048	Flail Bar Strap	1
	HB-38-16-100	Hex Bolt, $\frac{3}{8}$ - 16 x 1	1
	HNCL-38-16	Center Nylon Lock Nut, $\frac{3}{8}$ - 16	1
5	HHP-18	Bridge Pin, $\frac{1}{8}$	2
6	43-146	Frame	1
7	18-297	Cap Plug	2
8	HMB-58-14	Machine Bushing, $\frac{5}{8}$ x 14GA	10
9	26-047	Leveler Bar	1
10	26-041	Rasp Flail	32
11	21-260	Clevis	2
12	26-115	Mesh Finisher	1

INSTALLATION INSTRUCTIONS

1. Install flail bar strap (Ref 4) to center of mounting bar (Ref 3) with chain on top of flail bar strap and mounting bar bent away from you. Apply a light coat of lubricant to overall length of mounting bar.
2. Install one rasp flail (Ref 16) with knobby side down adjacent to sides of flail bar strap. Now install a flat washer (Ref 2) so it sits adjacent with the outside of the rasp flail. Continue to install flails with knobby sides down with washers between until you have 16 flails and washers on each side of bar strap. Force all flails tightly toward bar strap.
3. After all 32 flails have been installed, place one spacer (Ref 1) to each end of mounting bar adjacent to washer.
4. Install leveler bar (Ref 9) to mounting bar, with curved leveler bar resting on top on the smooth sides of flails. If all flails and washers do not fit snugly at this time, remove leveler bar and install enough machine bushings to ensure a snug fit. Then reinstall leveler bar.
5. Lay the frame (Ref 6) on the floor or bench with welded tabs facing up. Install ends of assembled mounting bar, with knobby sides of flails up, into welded tabs on each end of frame and secure with $\frac{1}{8}$ x 1 cotter pin.
6. Install flail bar strap (Ref 4) to center tab on frame with $\frac{3}{8}$ -16 x 1 Hex Bolt and $\frac{3}{8}$ -16 center Nylon Lock Nut. Loose fit is required. Do not over tighten.
7. Flip assembly over so knobby sides of flails are now facing down. Install hitch to frame with clevis pin (Ref 3) and cotter pin (Ref 24). The hitch should be attached to the frame as shown.
8. Install bar strap chain over welded pin on frame. Install leveler bar chain on to pin and secure in place with bridge pin. Use last bridge pin and clevis pin to hitch field finisher to your machine.

OPERATING INSTRUCTIONS

Running attachment with all flails down, flat on the surface, will provide a leveling function. Running attachment partially raised and flails at a 20° - 40° angle in relation to the level surface, will provide a finishing function. The flails increase down pressure for desired finish. Drive in wide circular patterns and increase or decrease ground speed to achieve desired finish.

43-043 FINISHING BRUSH KIT DRAWING

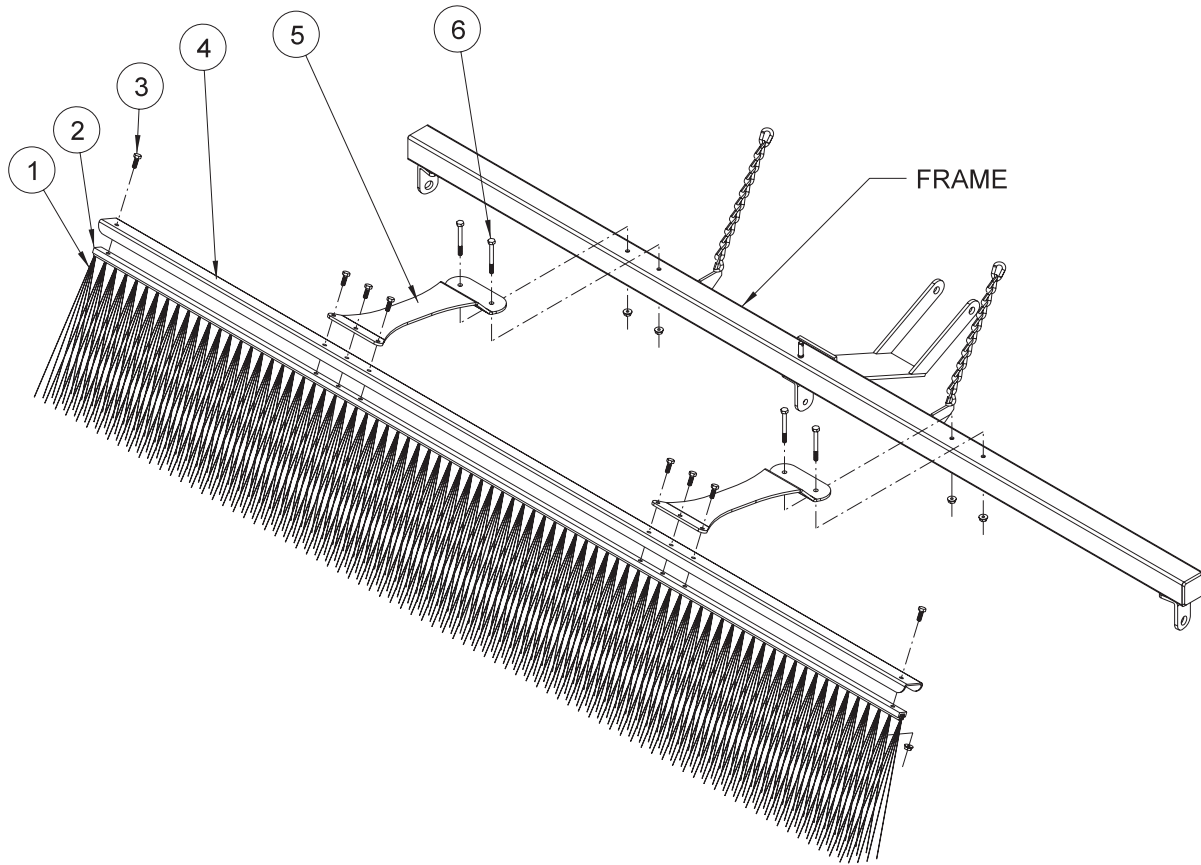

HOLE LOCATION

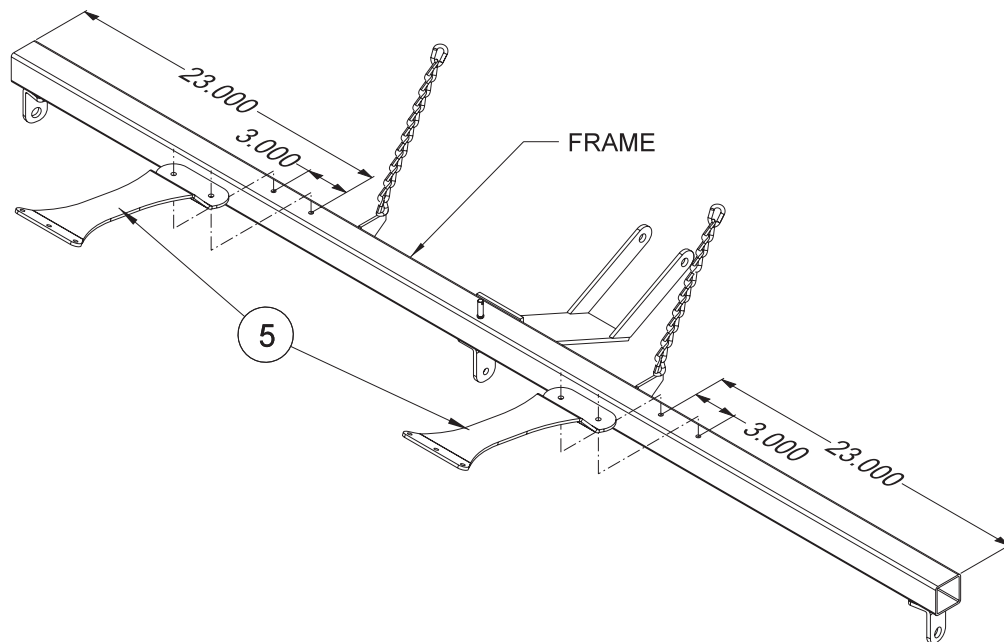

Rear Attachment

43-043 FINISHING BRUSH KIT PARTS LIST

REF#	PART#	DESCRIPTION	QUANTITY
1	13-682	Brush, 77 x 11	1
2	13-683	Brush Track	1
3	HB-14-20-075	Hex Bolt, $\frac{1}{4}$ - 20 x $\frac{3}{4}$	8
	HNFL-14-20	Flange Whiz-loc Nut, $\frac{1}{4}$ - 20	8
4	13-688	Brush Channel	1
5	43-041	Mount Bracket	2
6	HB-14-20-250	Hex Bolt, $\frac{1}{4}$ - 20 x $2\frac{1}{2}$	4
	HNFL-14-20	Flange Whiz-loc Nut, $\frac{1}{4}$ - 20	4

INSTALLATION INSTRUCTIONS

1. Remove the mesh finisher from your unit, it will not be used with the brush.
2. Place the brush (Ref 1) into the brush track (Ref 2). Place the brush channel (Ref 4) between the brush track and the mounting brackets (Ref 5). Now Hex Bolt the mounting brackets (Ref 5) to the brush track using the $\frac{1}{4}$ - 20 x $\frac{3}{4}$ " Hex Bolts and $\frac{1}{4}$ - 20 Flange Whiz-loc Nuts (Ref 3).
3. Four holes need to be drilled into the frame of the Flex Action Finisher to mount the brush. Drill two $\text{Ø}\frac{9}{32}$ holes 23" in from each end and 3" apart (see Reference drawing).
4. Mount the brush assembly to the frame using the four $\frac{1}{4}$ - 20 x $2\frac{1}{2}$ " Hex Bolts and $\frac{1}{4}$ - 20 Flange Whiz-loc Nuts (Ref 5).

43-008 DRAG MAT DRAWING

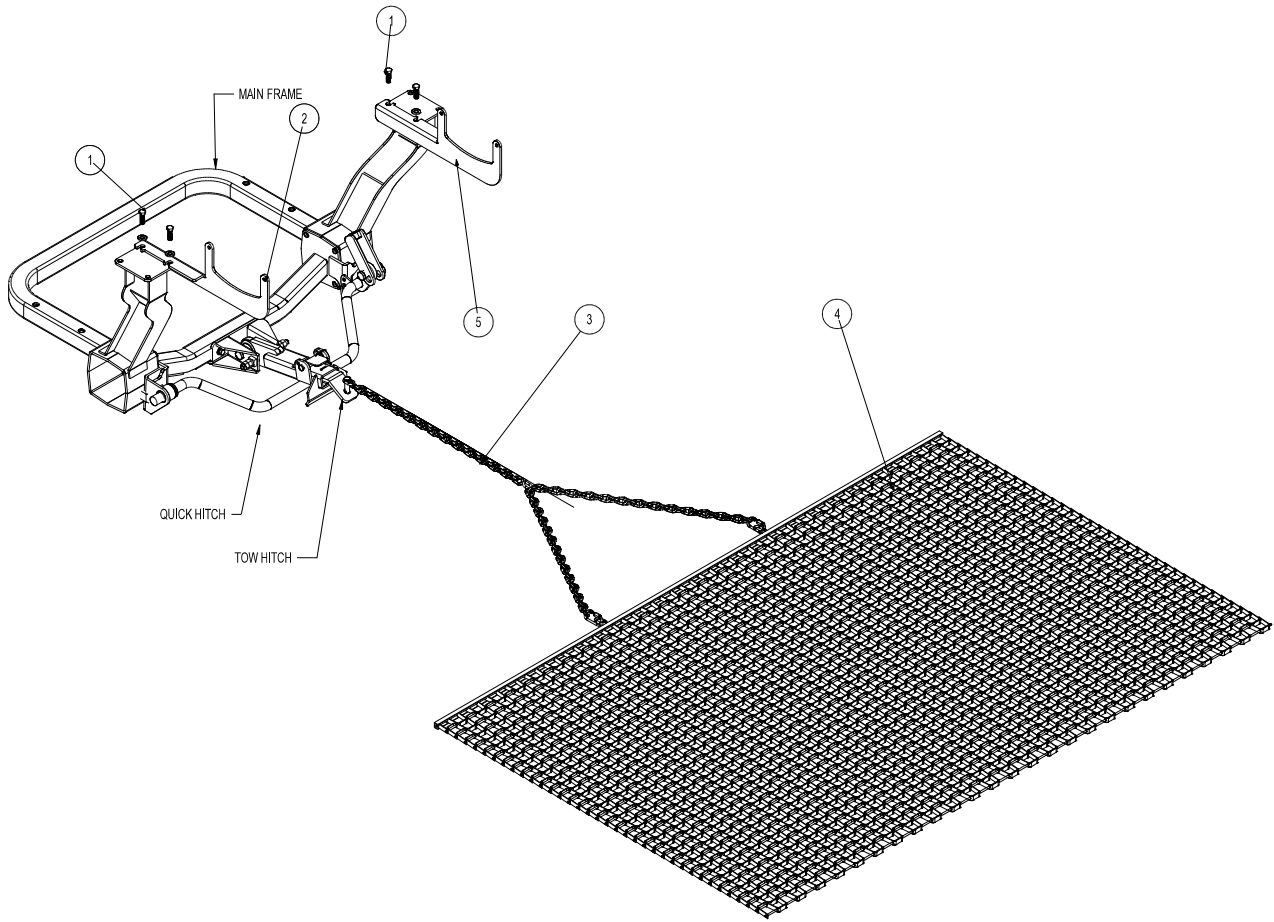

Rear Attachment

43-008 DRAG MAT PARTS LIST

REF#	PART#	DESCRIPTION	QUANTITY
1	HB-716-14-125	Hex Bolt, $\frac{7}{16}$ - 14 x $1\frac{1}{4}$	4
	HW-716	Washer, $\frac{7}{16}$	4
	HNTL-716-14	Nylon Lock Nut, $\frac{7}{16}$ -14	4
2	13-751	Right Carrier Mount	1
3	19-605	Drag Mat Chain	1
	HHP-18	Bridge Pin, $\frac{1}{8}$	1
4	19-601	Steel Drag Mat	1
5	13-752	Left Carrier Mount	1

INSTRUCTIONS

1. The Drag Mat Kit can be installed on all Super Star with or without the optional Roll Bars.
2. Remove the two insides Hex Bolts from the roll bar mounts. Install the flat washers and secure right and left carrier mounts on opposite sides. Tighten all hardware.
3. Install the tow hitch insert into the quick hitch. This is where the tow chain on the drag mat attaches to the machine.

45-176 72" DRAG MAT + FINISHER BRUSH DRAWING

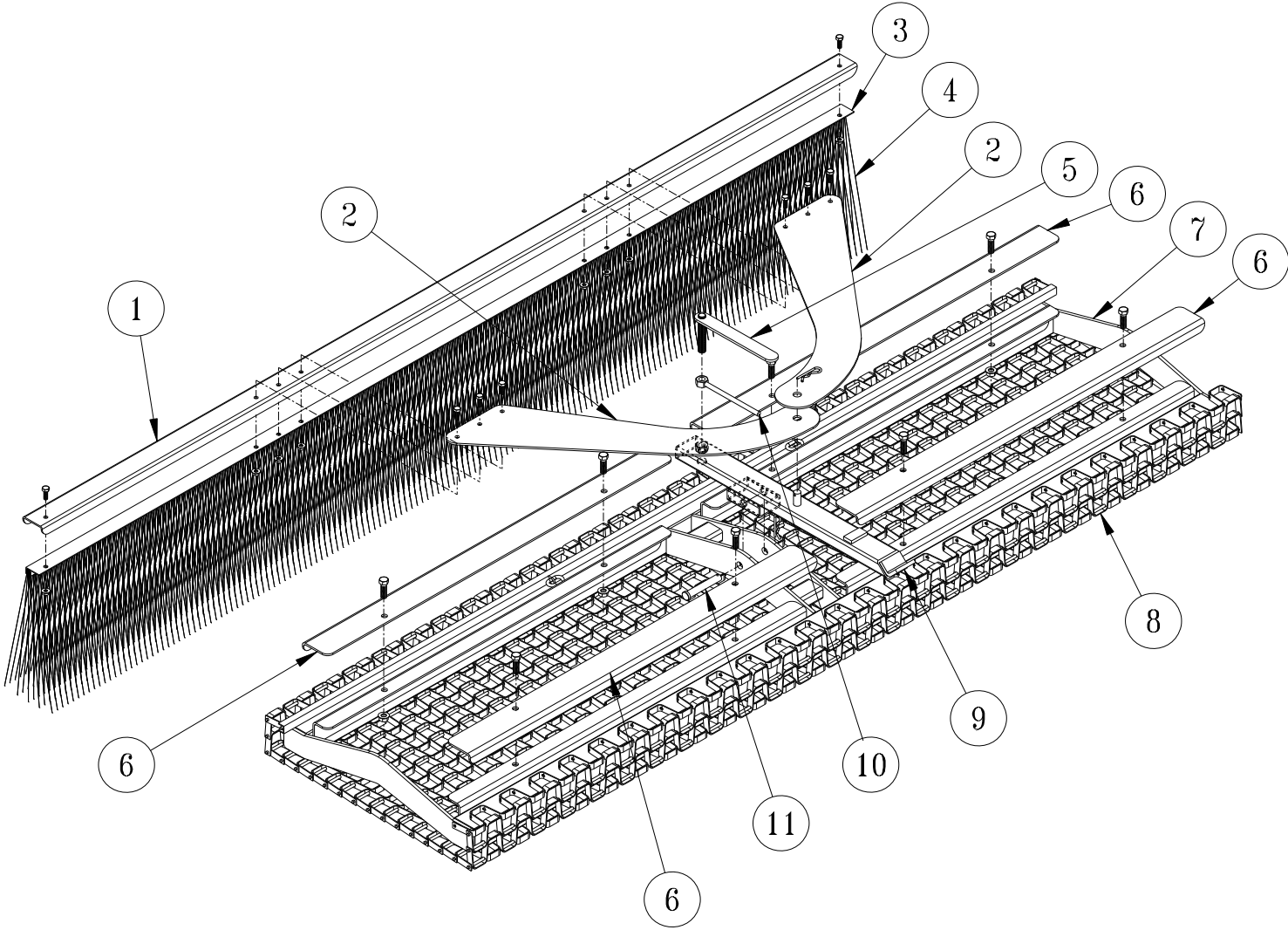

Rear Attachment

45-176 72" DRAG MAT + FINISHER BRUSH PARTS LIST

REF#	PART#	DESCRIPTION	QUANTITY
1	13-688	Brush Channel	1
	HB-14-20-075	Hex Bolt, 1/4 - 20 x 3/4	2
	HNFL-14-20	Flange Whiz-loc Nut, 1/4 - 20	2
2	43-168	Brush Mount Arm	2
	HB-14-20-075	Hex Bolt, 1/4 - 20 x 3/4	8
	HNFL-14-20	Flange Whiz-loc Nut, 1/4 - 20	8
3	13-683	Brush Track	1
4	13-682	Brush, 77 x 11	1
5	43-164	Adjustment Handle	1
6	43-166	Mat Clamp	4
	HB-38-16-125	Hex Bolt, 3/8 - 16 x 1 1/4	8
	HNFL-38-16	Flange Whiz-loc Nut, 3/8 - 16 x 1 1/4	8
7	43-165	Frame	1
8	45-167	Steel Mat, 72 x 29	1
9	43-162	Draw Bar	1
	HHP-18	Bridge Pin, 1/8	1
10	43-163	Lock Handle	1
11	HCP-12-300	Clevis Pin, 1/2 x 3	1
	HHP-18	Bridge Pin, 1/8	1

DRAG MAT ASSEMBLY INSTRUCTIONS

Some components of your **Drag Mat + Finisher Brush** have been assembled at the factory for your convenience.

1. Start by mounting the Draw bar (Ref 9) to the Frame (Ref 7) using the Clevis Pin and Bridge Pin (Ref 11). Position the Draw bar, using either set of holes, as illustrated.
2. Next, mount the Brush assembly (Ref 1, 3 & 4) to the Brush Mount Arms (Ref 2), as illustrated, using the (6) 1/4 - 20 x 3/4 Hex Bolts and 1/4 - 20 Flange Whiz-loc Nuts. Secure fasteners tight.
3. The holes on each of the Brush Mount Arms will line up. Mount to the pin on the Draw bar (Ref 9) and secure using the remaining Bridge Pin.
4. Thread the Lock Handle (Ref 10) on to the Adjustment Handle (Ref 5). Thread the Adjustment Handle into the nut on top of the Draw bar (Ref 9), continuing until the threaded rod is through the Draw bar tube. Turn the Lock Handle clockwise (↻) to lock the Adjustment handle in place.

Adjusting the **Steel Mat Finisher**.

Adjusting the leading edge (front) will affect the performance of the **Finisher**. Various field compositions and conditions can benefit from fine tuning of the **Finisher's** leading edge angle.

1. Release the Lock Handle (Ref 10) by holding the Adjustment Handle (Ref 5) and turning the Lock Handle counter-clockwise (↺).
2. To raise the leading edge (front) of the **Finisher**, turn the Adjustment Handle clockwise (↻). When you obtain your desired position, turn the Lock Handle clockwise (↻) to lock the Adjustment handle in place.
3. To lower the leading edge (front) of the **Finisher**, turn the Adjustment Handle counter-clockwise (↺). When you obtain your desired position, turn the Lock Handle clockwise (↻) to lock the Adjustment handle in place.

45-010 BOX GRADER DRAWING

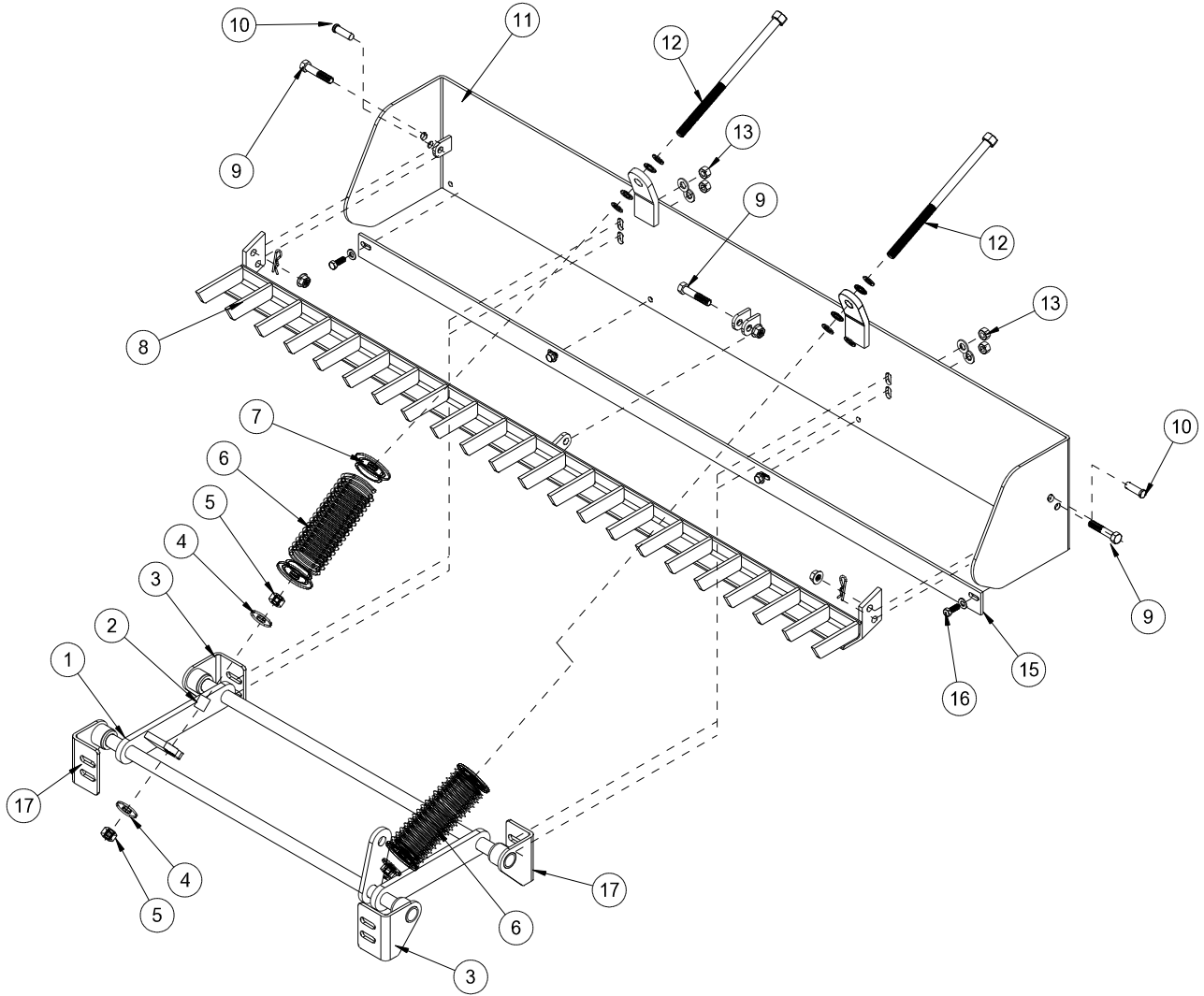

Rear Attachment

45-010 BOX GRADER PARTS LIST

REF#	PART#	DESCRIPTION	QUANTITY
1	45-141	Lift Assembly	1
2	34-215	Spacer	2
3	34-220	Right Pivot Bracket	2
	33-086	Bushing	2
4	HW-58	Flat Washer, $\frac{5}{8}$	4
5	HNTL-58-18	Nylon Lock Nut, $\frac{5}{8}$ - 18	2
	HN-58-18	Hex Nut, $\frac{5}{8}$ - 18	4
6	13-276	Compression Spring	2
7	13-277	Spring Pad	4
8	34-217	Break Up Bar	1
9	HB-12-13-200	Hex Bolt, $\frac{1}{2}$ -13 x 2	3
	HNTL-12-13	Nylon Lock Nut, $\frac{1}{2}$ - 13	3
10	HCP-12-150	Clevis Pin, $\frac{1}{2}$ x $1\frac{1}{2}$	2
	HHP-18	Bridge Pin, $\frac{1}{8}$	2
11	34-216	Blade Assembly	1
12	34-214	Spring Rod	2
	HMB-58-14	Machine Bushing, $\frac{5}{8}$ - 14GA	4
13	HB-12-13-125	Hex Bolt, $\frac{1}{2}$ - 13 x $1\frac{1}{4}$	4
	HW-716	Flat Washer, $\frac{7}{16}$	8
	HWL-12	Lock Washer, $\frac{1}{2}$	4
	HN-12-13	Hex Nut, $\frac{1}{2}$ -13	4
15	34-218	Cutter Blade	1
16	HB-38-16-125	Hex Bolt, $\frac{3}{8}$ - 16 x $1\frac{1}{4}$	4
	HW-38	Flat Washer, $\frac{3}{8}$	4
	HWL-38	Lock Washer, $\frac{3}{8}$	4
	HN-38-16	Nylon Lock Nut, $\frac{3}{8}$ - 16	4
17	34-219	Left Pivot Bracket	2
	33-086	Bushing	2

42-586Q GREEN STAR RBS MAIN FRAME DRAWING

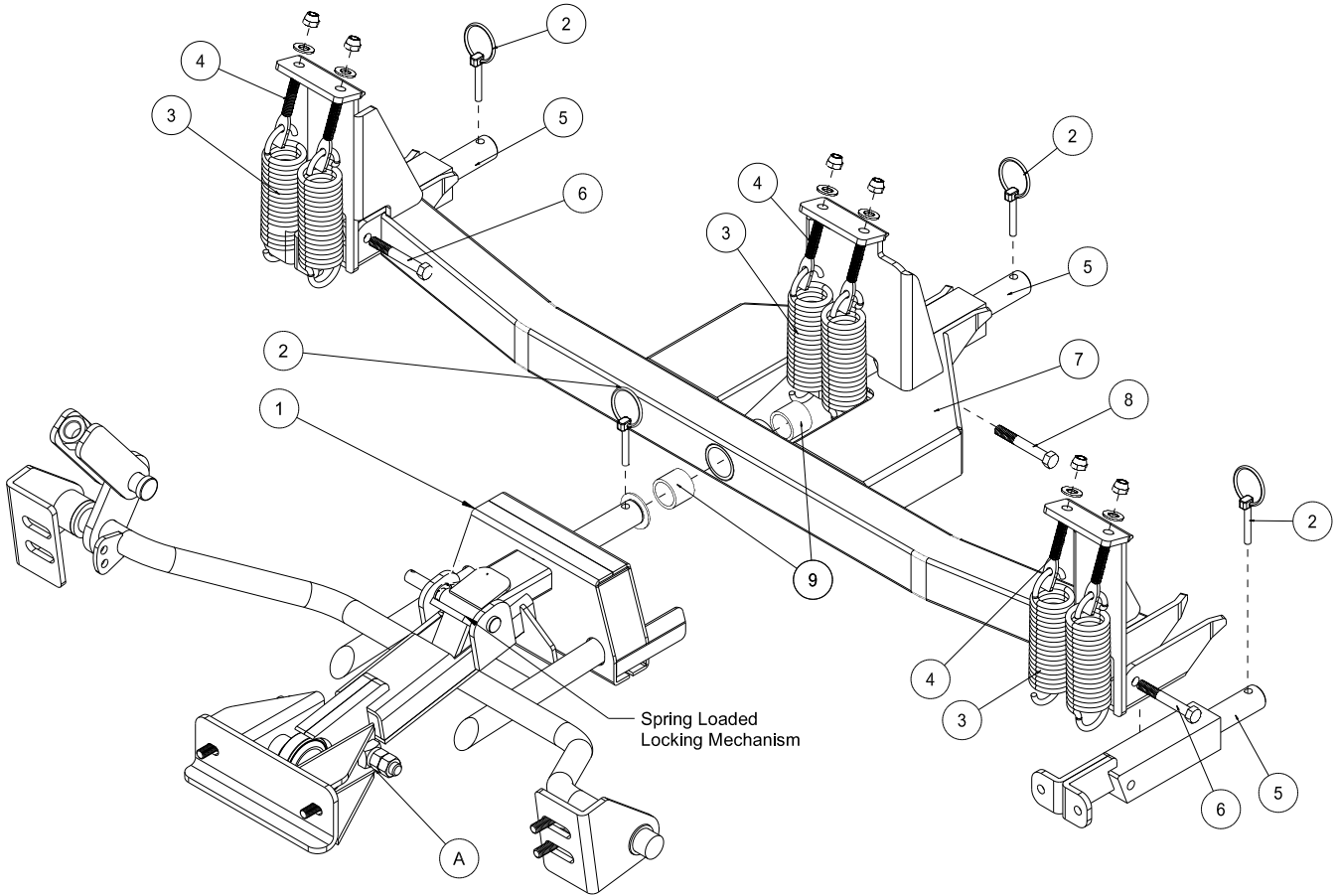

Rear Attachment

42-586Q GREEN STAR RBS MAIN FRAME PARTS LIST

REF#	PART#	DESCRIPTION	QUANTITY
1	43-155	Hitch	1
2	42-539	Lynch Pin, $\frac{5}{16}$	4
3	42-536	Spring	6
4	42-537	Spade Hex Bolt	6
	HNTL-38-16	Nylon Lock Nut, $\frac{3}{8}$ - 16	6
5	42-576	Spring Tower	3
6	HB-38-16-275	Hex Bolt, $\frac{3}{8}$ - 16 x $2\frac{3}{4}$	2
	HNTL-38-16	Nylon Lock Nut, $\frac{3}{8}$ - 16	2
7	42-577	Frame	1
8	HB-38-16-250	Hex Bolt, $\frac{3}{8}$ - 16 x $2\frac{1}{2}$	1
	HNCL-38-16	Center Nylon Lock Nut, $\frac{3}{8}$ - 16	1
9	18-295	Oilite Bushing (part of 42-577)	2

42-581 GREEN STAR RBS ROLLER SET (3) DRAWING

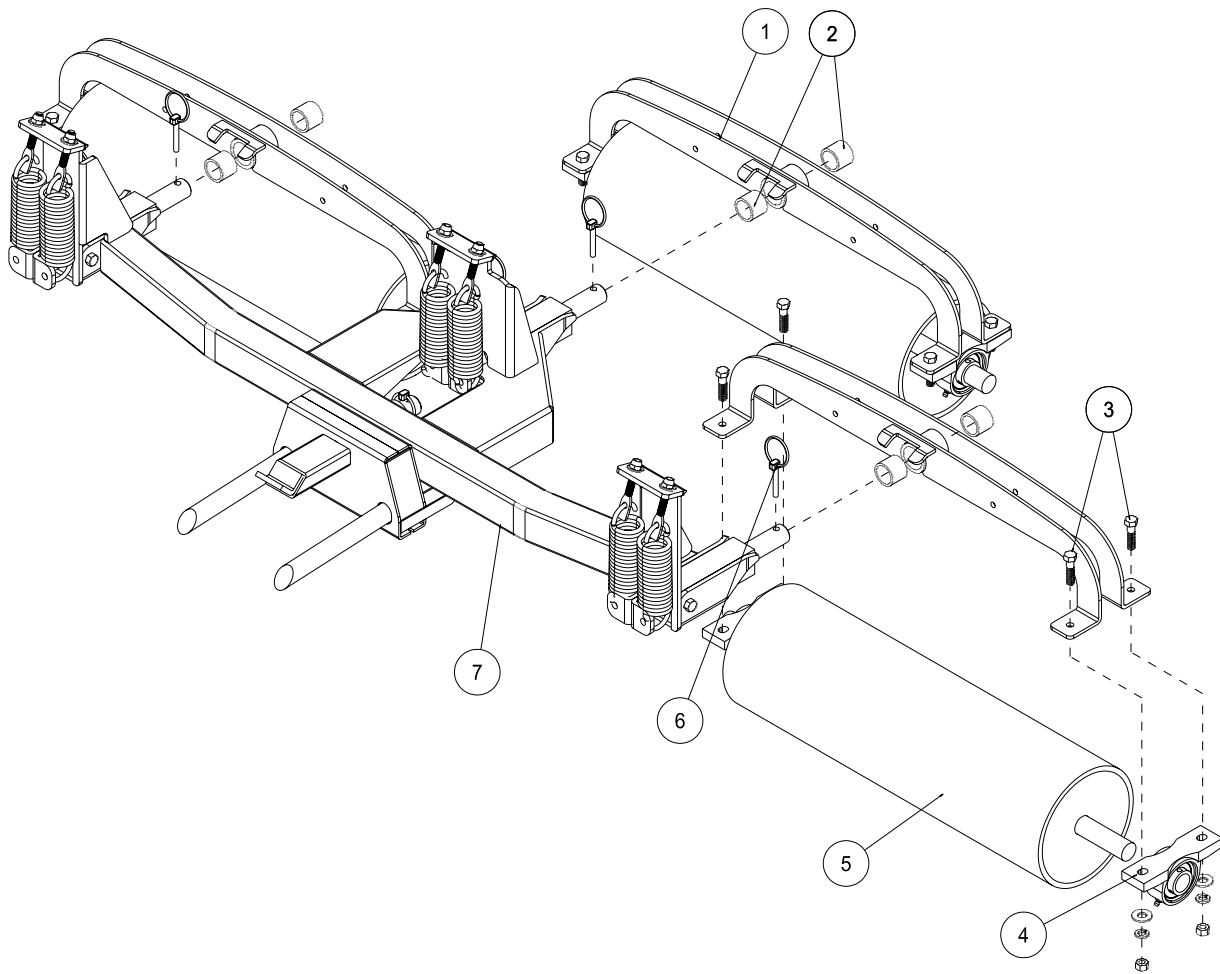

Rear Attachment

42-581 GREEN STAR RBS ROLLER SET (3) PARTS LIST

REF#	PART#	DESCRIPTION	QUANTITY
1	42-574	Fork	3
2	18-295	Oilite Bushing (part of 42-574)	6
3	HB-38-16-150	Hex Bolt, $\frac{3}{8}$ - 16 x $1\frac{1}{2}$	12
	HWL-38	Lock Washer, $\frac{3}{8}$	12
	HW-38	Flat Washer, $\frac{3}{8}$	12
	HN-38-16	Hex Nut, $\frac{3}{8}$ - 16	12
4	11-094	Pillow Block	6
5	42-584	Roller	3
6	42-539	Lynch Pin $\frac{5}{16}$ (part of main frame)	3
7	42-586Q	Green Star RBS Main Frame	1

ADJUSTMENTS AND OPERATION INSTRUCTIONS

ADJUSTMENT

The springs are preset for maximum down pressure, and should not need to be adjusted. If you feel the need to adjust the springs please call for further instructions. The unit comes pre-adjusted for most models. The four adjustment holes on the hitch are for making sure all three rollers are touching the ground at the same pressure. When installing roller system start with the lower mounting holes on hitch.

Tire pressure should be 4 psi in the front and 7 psi in the rear tire for best traction.

OPERATION

Make sure the rolling system has been installed and adjusted properly for your model of bunker rake. Always transport in fully raised position. Always remove flag pole before rolling green. Do not stop on green while rolling. Do not roll up steep slopes or loss of traction may result. Do not turn while rolling.

To begin rolling, lower unit all the way down as you come across collar and continue straight across green until reaching other collar and raise as you come off of green. Overlap stripes the same as if you were mowing.

42-585 GREEN STAR RBS BRUSH SET (3) DRAWING

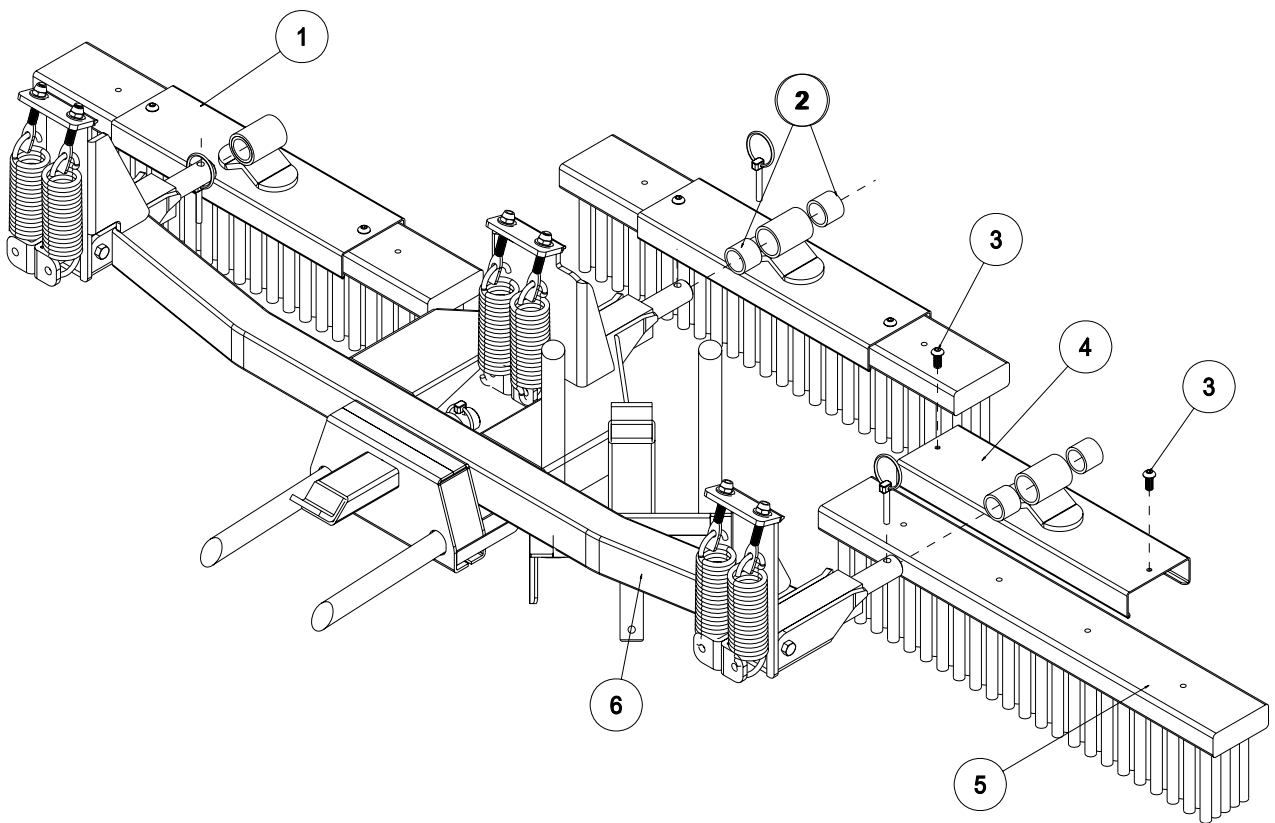

Rear Attachment

42-585 GREEN STAR RBS BRUSH SET (3) PARTS LIST

REF#	PART#	DESCRIPTION	QUANTITY
1	42-539	Lynch Pin, $\frac{5}{16}$ (part of main frame)	4
2	18-295	Oilite Bushing (part of 42-579)	6
3	HSPP-516-18-075	Phillip Head Screw, $\frac{5}{16}$ - 18 x $\frac{3}{4}$	6
4	42-579	Brush Bracket	3
5	42-545	Brush Head	3
6	42-586Q	Green Star RBS Main Frame	1

ADJUSTMENTS AND OPERATION INSTRUCTIONS

ADJUSTMENT

The springs are preset for maximum down pressure, and should not need to be adjusted. If you feel the need to adjust the springs please call for further instructions. The unit comes pre-adjusted for most models. The four adjustment holes on the hitch are for making sure all three brushes are touching the ground at the same pressure. When installing brush system start with the lower mounting holes on hitch.

Tire pressure should be 4 psi in the front and 7 psi in the rear tire for best traction.

OPERATION

Make sure the brush system has been installed and adjusted properly for your model of bunker rake. Always transport in fully raised position. Always remove flag pole before brushing green. Do not stop on green while brushing. Do not brush up steep slopes or loss of traction may result. Do not turn while brushing.

For drag brushes use hydraulics to control the amount of down pressure required to move your top dressing material. We recommend reversing drag brushes after each use for even wear. To begin brushing, lower unit as you come across collar and continue straight across green until reaching other collar and raise as you come off of green. Overlap stripes the same as if you were mowing.

42-582 GREEN STAR RBS SPIKER SET (3) DRAWING

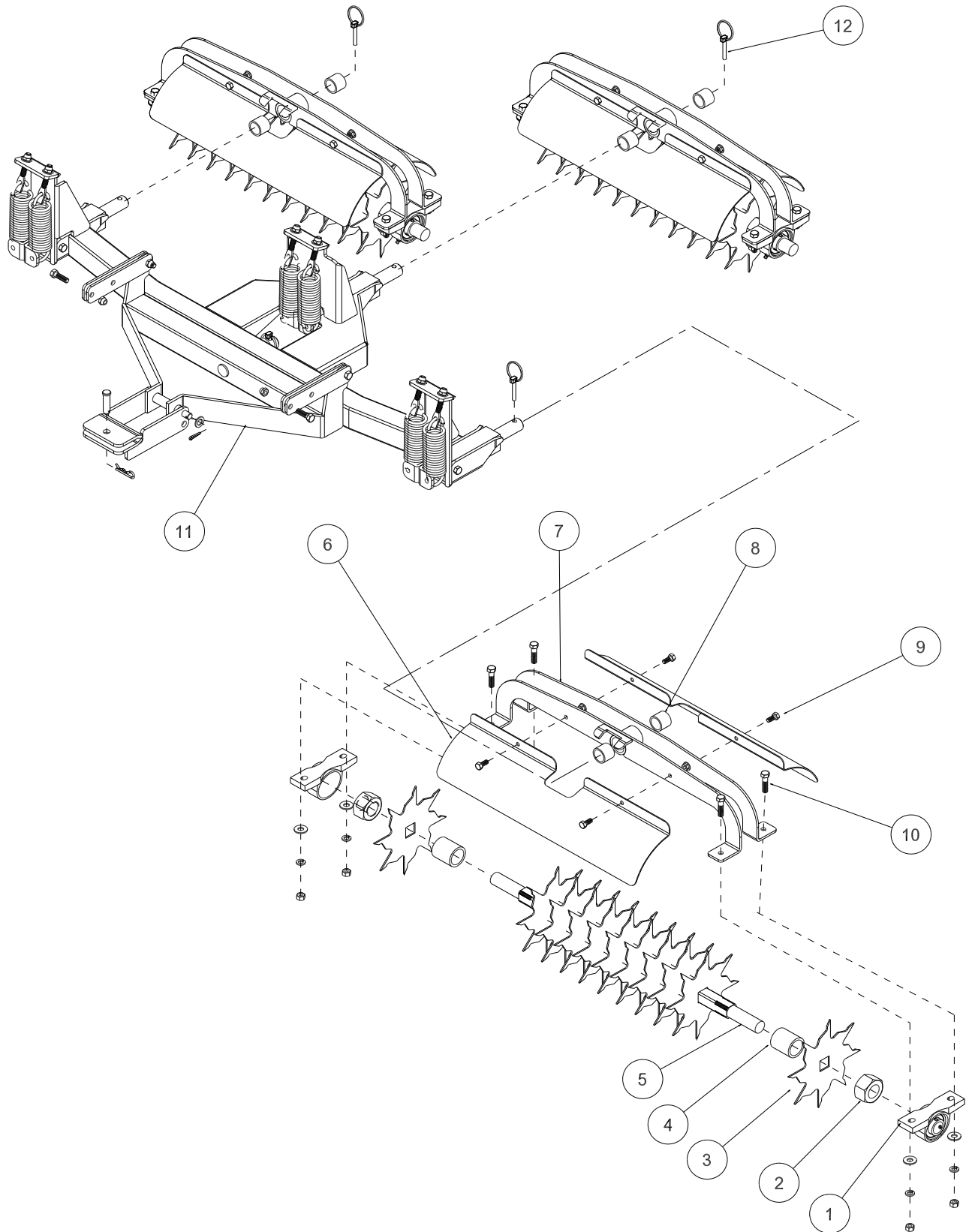

Rear Attachment

42-582 GREEN STAR RBS SPIKER SET (3) DRAWING

REF#	PART#	DESCRIPTION	QUANTITY
1	11-094	Pillow Block	6
2	HNJ-114-12	Jam Nut, 1 ¹ / ₄ - 12	6
3	42-583	Spiker Blade	33
4	8965-1.875	Spiker Blade Spacer (1.875")	30
5	42-554	Spiker Shaft	3
6	42-578	Spiker Cover	6
7	42-574	Fork	3
8	18-295	Oilite Bushing (part of 42-574)	6
9	HB-516-18-075	Hex Bolt, ⁵ / ₁₆ - 18 x ³ / ₄	12
	HNTL-516-18	Nylon Lock Nut, ⁵ / ₁₆ - 18	12
10	HB-38-16-150	Hex Bolt, ³ / ₈ - 16 x 1 ¹ / ₂	12
	HWL-38	Lock Washer, ³ / ₈	12
	HW-38	Flat Washer, ³ / ₈	12
	HN-38-16	Hex Nut, ³ / ₈ - 16	12
11	42-586Q	Green Star RBS Main Frame	1
12	42-539	Lynch Pin, ⁵ / ₁₆ (part of main frame)	3

ADJUSTMENTS AND OPERATION INSTRUCTIONS

ADJUSTMENT

The springs are preset for maximum down pressure, and should not need to be adjusted. If you feel the need to adjust the springs please call for further instructions. The unit comes pre-adjusted for most models. The four adjustment holes on the hitch are for making sure all three spikers are touching the ground at the same pressure. When installing spiker system start with the lower mounting holes on hitch.

Tire pressure should be 4 psi in the front and 7 psi in the rear tire for best traction.

OPERATION

Make sure the spiker system has been installed and adjusted properly for your model of bunker rake. Always transport in fully raised position. Always remove flag pole before spiking green. Do not stop on green while spiking. Do not spike up steep slopes or loss of traction may result. Do not turn while spiking.

To begin spiking, lower unit all the way down as you come across collar and continue straight across green until reaching other collar and raise as you come off of green. Overlap stripes the same as if you were mowing.

INSTALLATION

Spiker blades must be installed so that the jagged side of the tooth cuts into the turf first. This allows only a piercing of the turf, whereas if the straight edge of the spiker blades enters first it will act more as a cutting effect.

43-009 72" COCO MAT FINISHER DRAWING

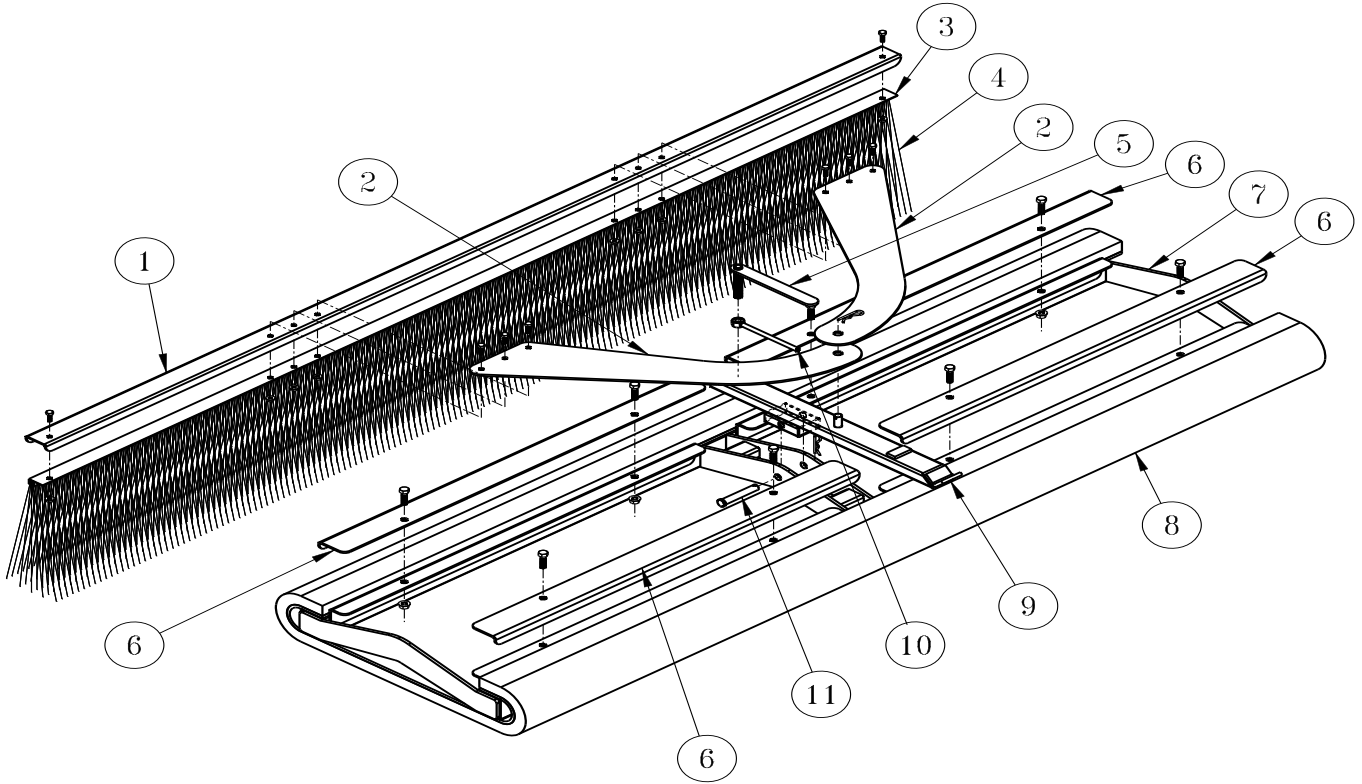

Rear Attachment

72" COCO MAT FINISHER PARTS LIST

REF#	PART#	DESCRIPTION	QUANTITY
1	13-688	Brush Channel	1
	HB-14-20-075	Hex Bolt, $\frac{1}{4}$ - 20 x $\frac{3}{4}$	2
	HNFL-14-20	Flange Whiz-loc Nut, $\frac{1}{4}$ - 20	2
2	43-168	Brush Mount Arm	2
	HB-14-20-075	Hex Bolt, $\frac{1}{4}$ - 20 x $\frac{3}{4}$	6
	HNFL-14-20	Flange Whiz-loc Nut, $\frac{1}{4}$ - 20	6
3	13-683	Brush Track	1
4	13-682	Brush, 77 x 11	1
5	43-164	Adjustment Handle	1
6	43-166	Mat Clamp	4
	HB-38-16-125	Hex Bolt, $\frac{3}{8}$ - 16 x $1\frac{1}{4}$	8
	HNFL-38-16	Flange Whiz-loc Nut, $\frac{3}{8}$ - 16 x $1\frac{1}{4}$	8
7	43-165	Frame	1
8	43-167	Coco Mat, 27 x 72	1
9	43-162	Draw Bar	1
	HHP-18	Bridge Pin, $\frac{1}{8}$	1
10	43-163	Lock Handle	1
11	HCP-12-300	Clevis Pin, $\frac{1}{2}$ x 3	1
	HHP-18	Bridge Pin, $\frac{1}{8}$	1

Some components of your **Coco Mat Finisher** have been assembled at the factory for your convenience.

1. Start by mounting the Draw bar (Ref 9) to the Frame (Ref 7) using the Clevis Pin and Bridge Pin (Ref 11). Position the Draw bar, using either set of holes, as illustrated.
2. Next, mount the Brush assembly (Ref 1, 3 & 4) to the Brush Mount Arms (Ref 2), as illustrated, using the (6) $\frac{1}{4}$ - 20 x $\frac{3}{4}$ Hex Bolts and $\frac{1}{4}$ - 20 Flange Whiz-loc Nuts. Secure fasteners tight.
3. The holes on each of the Brush Mount Arms will line up. Mount to the pin on the Draw bar (Ref 9) and secure using the remaining Bridge Pin.
4. Thread the Lock Handle (Ref 10) on to the Adjustment Handle (Ref 5). Thread the Adjustment Handle into the nut on top of the Draw bar (Ref 9), continuing until the threaded rod is through the Draw bar tube. Turn the Lock Handle clockwise (↻) to lock the Adjustment handle in place.

Adjusting the **Coco Mat Finisher**.

Adjusting the leading edge (front) will affect the performance of the **Finisher**. Various field compositions and conditions can benefit from fine tuning of the **Finisher's** leading edge angle.

1. Release the Lock Handle (Ref 10) by holding the Adjustment Handle (Ref 5) and turning the Lock Handle counterclockwise (↺).
2. To raise the leading edge (front) of the **Finisher**, turn the Adjustment Handle clockwise (↻). When you obtain your desired position, turn the Lock Handle clockwise (↻) to lock the Adjustment handle in place.
3. To lower the leading edge (front) of the **Finisher**, turn the Adjustment Handle counterclockwise (↺). When you obtain your desired position, turn the Lock Handle clockwise (↻) to lock the Adjustment handle in place.

43-170 RAHN GROOMER

Infield Groomer Model GL650

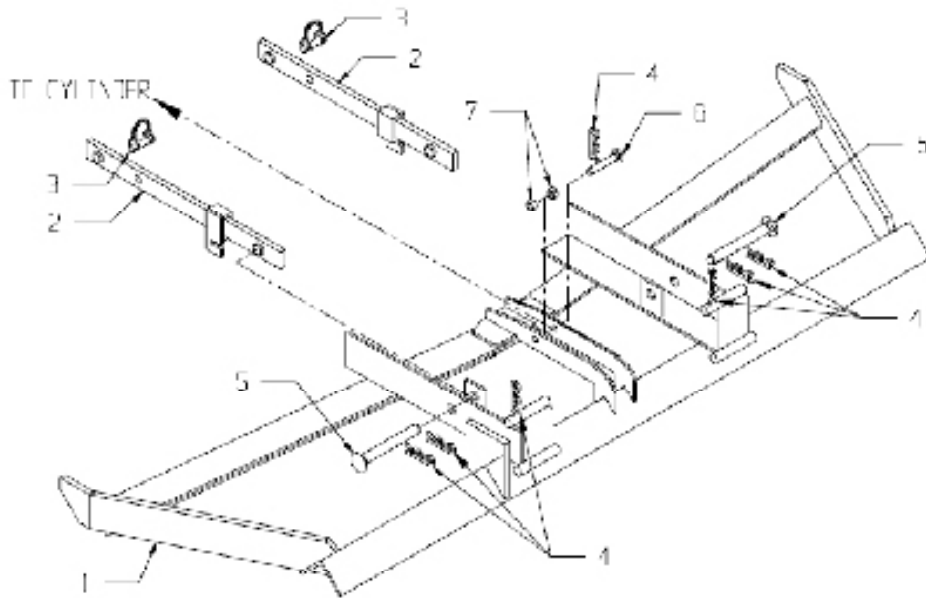

Base Unit, Infield Groomer

REF#	PART#	DESCRIPTION	QUANTITY
1	GL650-1	Groomer Frame	1
2	GL650-3	Pull Arms, Set (includes 2 arms)	1
3	HP8-09-01	Pull Arm Locking Pins, Set (included 2 pins)	1
4	HP-8-10	Hitch Pin	7
5	HP-8-02	6" Mounting Pin Set.(Included 2 pins)	1
6	HP8-03	Mounting Pin, 3" x 1/2"	1
7	HP-8-382	Spacer (Set of 2)	1

**Infield Groomer
Model GL650**

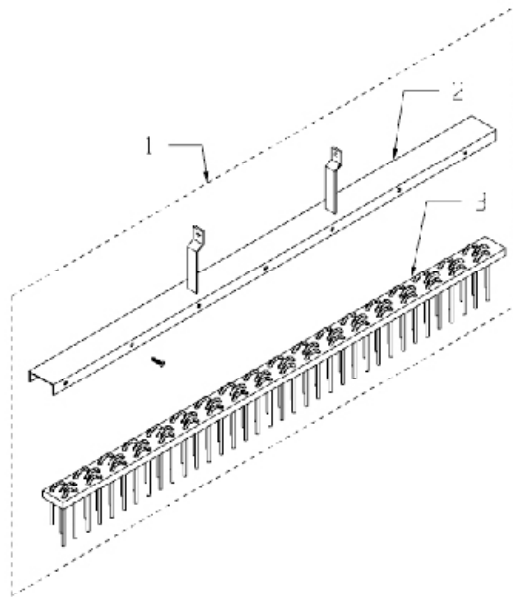

6' Broom Assembly

REF#	PART#	DESCRIPTION	QUANTITY
1	GL650-6	Broom Assembly, Complete	1
2	GL650-6-2	Broom Channel with Arms	1
3	GL650-6-1	Replacement Broom	1

Rear Attachment

Infield Groomer Model GL650

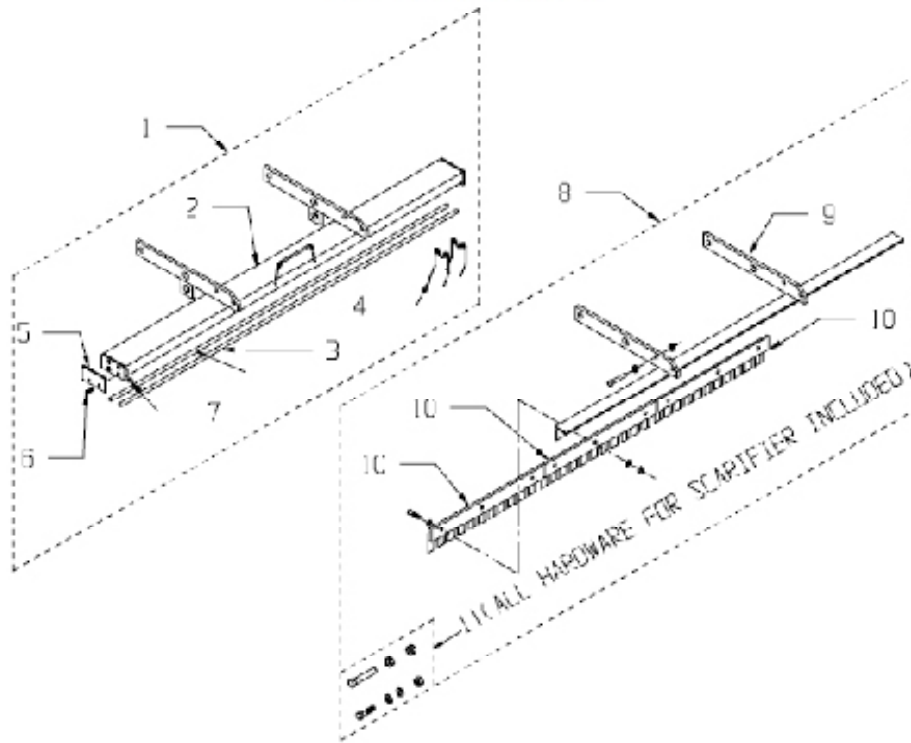

Scarifier Options

REF#	PART#	DESCRIPTION	QUANTITY
1	GL650-4-10	Spring Tine Assembly, Complete	1
2	GL650-4-10-1	Spring Tine Channel with Arms	1
3	GL650-4-10-2	Rods, 1/2" x 60"	2
4	GL650-4-15	Spring Tine Replacement Set (includes 38 pcs)	1
5	GL650-4-10-3	End Cap	1
6		HHCS, 1/4 x 3/4	2
7		Nylon Lock Nut, 1/4	2
8	GL650-4	Scarifier Assembly	1
9	GL650-4-1-1	5 Foot Scarifier Angle	1
10	GL650-4-5-3	Scarifier Replacement Set	1
11	GL650-4-9	Hardware Package	1



Picture #1



Picture #2

SMITHCO QUICK ATTACH MOUNTING INSTRUCTIONS

- 1. INSTALL RAHN CENTER LIFT ASSEMBLY INTO THE SMITHCO QUICK ATTACH MOUNTING SLOT UNTIL IT ENGAGES WITH THE SPRING ASSISTED STOP. MAKE SURE THE 3/4" RODS ARE BELOW THE QUICK ATTACH CROSS MEMBER. (PICTURE #1)**
- 2. INSTALL THE RAHN PULL ARM BRACKETS (LEFT & RIGHT) ON TOP OF THE BRACKETS USED FOR THE QUICK ATTACH SYSTEM USING THE HARDWARE PROVIDED. WHEN INSTALLING THE BRACKETS, THE HEX BOLT HOLES ARE LOCATED TOWARD THE WHEELS AND THE EARS OF THE BRACKET ARE TO THE INSIDE.**
- 3. REMOVE CLEVIS PIN IN THE ROD END OF THE CYLINDER. INSTALL CYLINDER MOUNT EXTENDER OVER EXISTING EAR ON CROSS MEMBER. TIGHTEN HEX BOLT AND REPLACE PIN. (PICTURE #2)**

TYPHOON PARTS LIST

REF#	PART#	DESCRIPTION	QUANTITY
1	HB-34-10-800	Hex Bolt, $\frac{3}{4}$ - 10 x 8	2
	HNTL-34-10	Nylon Lock Nut, $\frac{3}{4}$ -10	2
2	72-135	Castor Wheel Spacer	4
3	78-012	Tire and Wheel	2
4	18-223	Flange Bushing (part of 41-520)	4
5	41-520	Frame	1
6	29-584	Adjustment Spacer $\frac{1}{2}$ "	4
7	42-539	Lynch Pin	2
8	29-585	Adjustment Spacer, 1"	2
9	HB-12-13-350	Hex Bolt, $\frac{1}{2}$ -13 x 3 $\frac{1}{2}$	1
	HNTL-12-13	Nylon Lock Nut, $\frac{1}{2}$ "	2
	15-727	Switch Actuator, no light	1
	15-728	Switch Body, On-Off-On	1
	15-730	Mount Panel Plug	1
11	41-522	Quick Hitch Bar	1
12	41-532	Pump with 11 HP Honda Engine	1
	41-532-01	Impeller, Wear Plate, Gasket and Seal	1
	41-532-02	Gasket	1
	41-532-03	Seal	1
13	18-376	Close Nipple, 3"	2
14	41-530	Swivel Joint, 3"	1
15	18-382	2.5" Suction Hose	1
16	41-527	Band Clamp, 2.5"	2
17	41-529	Discharge Tube	1
18	41-525	Turnbuckle	1
19	18-375	King Nipple, 2.5"	1
20	18-378	Bushing, 3" x 2.5"	1
21		U-1 300 Amp Battery (not supplied)	1
22	8-603	Battery Strap	1
23	41-531	3" Basket Strainer	1
24	18-380	Check Valve, 3"	1
25	18-379	Plastic Elbow	1
26	18-374	King Nipple, 3"	1
27	41-526	Band Clamp, 3"	2
28	8820-8	Machine Chain, 8 links	1
29	18-381	3" Suction Hose	1
30	41-521	Hose Boom	1
	HG-14-28-180	Grease Fitting, $\frac{1}{4}$ - 28 x 180°	1
31	16-754	Actuator with 8" Stroke	1
	HCP-12-225	Clevis Pin, $\frac{1}{2}$ x 2 $\frac{1}{4}$	2
	HP-18-100	Cotter Pin, $\frac{1}{8}$ x 1	2
32	41-523	Pivot Rod	1
	HHP-18	Bridge Pin, $\frac{1}{8}$	2
33	72-134	Castor Wheel	1

TYPHOON WIRING

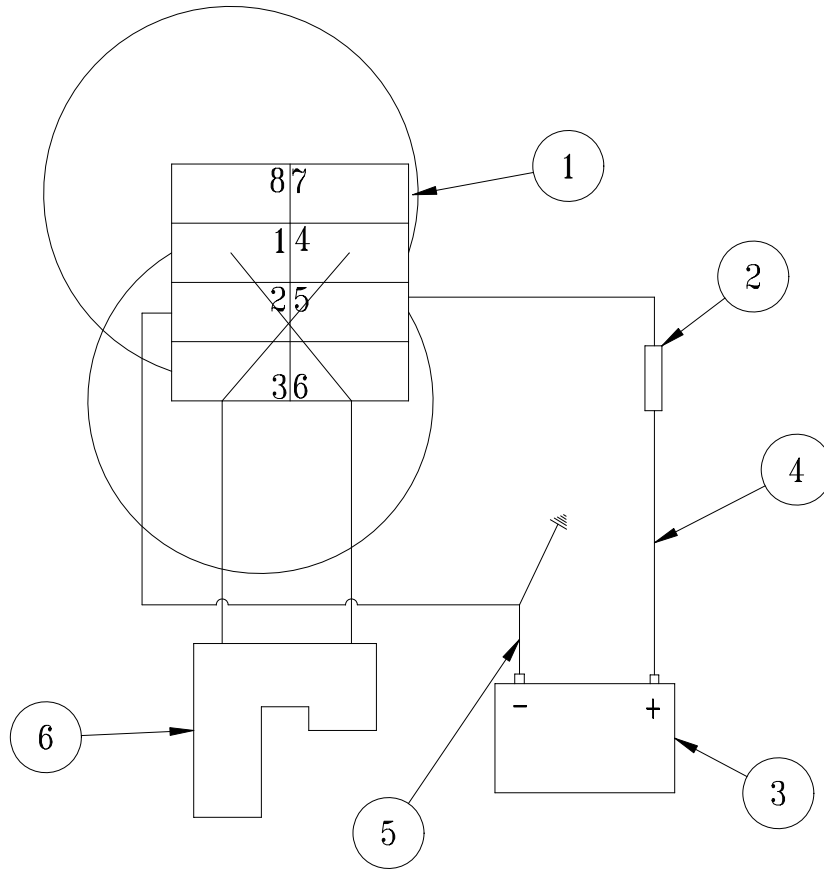

WIRING PARTS LIST

REF#	PART#	DESCRIPTION	QUANTITY
1	15-727	Switch Actuator, no light	1
	15-728	Switch Body, On-Off-On	1
2	77-261	Circuit Breaker, 40 amp	1
	8977	Circuit Breaker Boot	1
3		U-1 300 Amp Battery (not supplied)	1
4	22-056	Cable	1
	12-031	Battery Boot	1
5	22-065	Starter Cable	1
6	16-754	Actuator	1
	41-524	Wire Harness	1
	16-088	Decal, Moving Parts Hot	1
	25-286	Decal, Pinch Points	2
	25-298	Decal, Warning, Hot	1

Rear Attachment

 **WARNING**

READ ENGINE MANUAL PRIOR TO STARTING THIS MACHINE.
Machine is shipped with NO OIL in engine.
Fill Engine with oil as suggested in Engine Manual.

1. You must prime pump before starting the engine. To do so, insert garden hose in Discharge Tube and fill system to full. Full is when you see water in both suction hoses.
2. Fill engine up with 4-stroke motor oil as advised in the engine manual.
3. Install a U-1 300 Amp Battery into the battery box on the right side of the engine. Connect battery cables and strap battery into place.
4. Make yourself familiar with engine controls located on the engine by reading the Engine Owner's Manual.
5. Once the pump is primed, battery installed, and the engine oil is filled you may hook the Typhoon up to the Super Star Bunker Rake.
6. The Typhoon is equipped with a quick hitch attachment. Insert quick hitch bar into hitch on Super Star and lock in place with lock pin.
7. There are 1/2" and 1" spacers on the castor wheels that can be arranged in any combination to achieve the desired height. Please keep both side adjusted the same.
8. Transport the Typhoon to the water hole that needs to be siphoned. Back Typhoon to edge of water.
9. Using the rocker switch on the left side of the engine, lower the boom and suction screen into the water.
10. Stand clear of the discharge tube. Make sure the discharge tube is pointing in a direction that is free of bystanders and buildings.
11. Start engine. There will be immediate water discharge from the discharge tube. There is a swivel tube that allows you to turn the discharge in any direction you desire. There is also a turnbuckle that can be lengthened to give a longer flow or shortened for a closer distance. For best performance keep hand on discharge tube to prevent it from straying.
12. When water is siphoned, shut off engine, leaving water in the pump and discharge hose, so you do not run the pump dry.

 **WARNING**

DO NOT RUN THE PUMP DRY!

13. Using the rocker switch, raise boom out of the water hole.

41-532 PUMP DRAWING

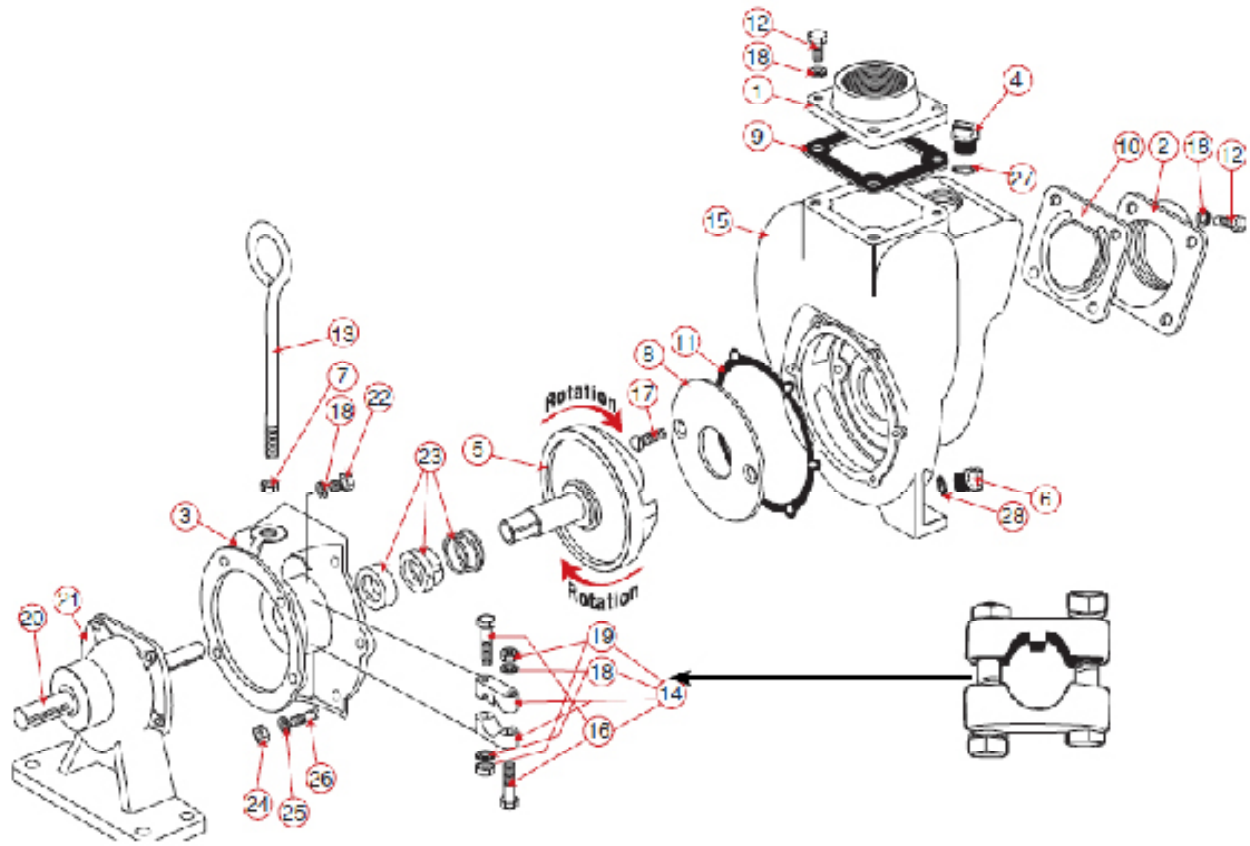

Rear Attachment

41-532 PUMP REPLACEMENT PARTS LIST

REF#	PART#	DESCRIPTION	QUANTITY
1	41-532-07	NPT Outlet Flange	1
2	41-532-05	NPT Inlet Flange	1
3		Adapter for Gas Engine	1
4	41-532-10	Plug	1
5*		Impeller & Drive Shaft for Gas Engine	1
6	41-532-11	Plug	1
7		$\frac{5}{8}$ SS Jam Nut	1
8*		Wear Plate	1
9	41-532-06	EPDM Outlet Gasket	1
10	41-532-04	Gasket Check Valve Assembly	1
11*	41-532-02	Adapter Gasket	1
12		SS Cap Screw HXHD, $\frac{3}{8}$ -16 x $1\frac{1}{8}$	8
13		Handle	1
14		Clamp Assembly	1
15	41-532-08	Pump Housing	1
16		Hex Bolt, $\frac{3}{8}$ - 24 x $2\frac{1}{4}$	2
17*		Wear Plate Flat Head Screw	2
18		Lock Washer, $\frac{3}{8}$	8
19		SS Hex Nut, $\frac{3}{8}$ x 24	1
20		1" Shaft	1
21		Bearing Pedestal	2
22		Hex Bolt	4
23*	41-532-03	Viton Seal Assembly	1
24		SS Hex Nut, $\frac{3}{8}$ - 16	6
25		SS Lock Washer, $\frac{3}{8}$	6
26		SS Stud, $\frac{3}{8}$ - 16 x $\frac{3}{8}$ -24 x $1\frac{1}{2}$	6
27	41-532-12	O-ring	1
28	41-532-13	O-ring	1
	41-532-01	Repair Kit (includes * items)	

