



Spray Star 1110
Truck Model 10-100-H

Manual System 1101
TeeJet Radion[®] 8140 1102
TeeJet[®] 744 1104
TeeJet Radion/DynaJet[®] 1105/1108
Ag Leader[®] 1115-AG/1118-AG

SN: 100769

Product Support:

Hwy 55 & Poplar Ave; Cameron WI 54822

1-800-891-9435 productsupport@smithco.com

CONTENTS

Introduction

Introduction.....	1-3
Safe Practices	2
Specification	3
Optional Equipment.....	3

Service

Service.....	4-9
Maintenance	4-6
Storage	6
Service Chart.....	7
End User's Service Chart.....	8
Adjustments	9

Diagrams

Diagrams	10-13
Wiring Diagram.....	10-11
Hydraulic Diagram.....	12-13
Fitting Torque Charts	13

Parts

Parts.....	14-45
Body and Frame	14-15
Engine Hood and ROPs	16-17
Control Panel.....	18-19
Foot Pedal and Linkage.....	20-21
Front Axle	22-23
Seat Console	24-25
Oil Tank and Oil Filter	26-27
CARB Canister and Fuel Tank.....	28-29
Pump	30-31
Engine and Spray Pump.....	32-33
Park Brake and Rear Axle	34-35
Spray Tank.....	36-37
Turbo-Quad Agitator	38
10-510 Wheel Motor	39
15-301 Orbitrol.....	40-41
45-373 DDC20 Piston Pump	42-43
15-984 Hypro® Pump.....	44
20-684 Flow Meter.....	45

Accessories

Reference

Spray Systems.....	46-99
1101 Plumbing (Manual Valve).....	46-47
10-648 3-Way Manual Valve.....	48-79
1102 Plumbing (TeeJet® Radion 8140).....	50-51
1104 Plumbing (TeeJet® 744)	52-53
1102 Wiring (TeeJet® Radion 8140).....	54
1104 Wiring(TeeJet® 744)	55
System Control Mounts	56-57
1105/1108 Plumbing (Star Command I)	58-59
1105/1108 Module Mounts	60
1105/1108 DynaJet Wiring.....	61
1115-AG/1118-AG Plumbing (Star Command II)	62-65
1115-AG/1118-AG Module Mounts	66-67
Star Command II Wiring	68-71
15-988 3-way Flanged Ball Valve	72
15-737/14-628 Flanged Strainer.....	73
14-801 Agitator Strainer - 50 Mesh.....	74
15-743 Manifold Ball Valve	75
14-673 2-way Shut Off Valve.....	76
20-817 Regulator Valve	77
20-785 Regulator Valve	78
Boom Hinge.....	79
17-585 18' Boom	80-83
17-585 1102/1104 Plumbing.....	84
17-585 1108 Plumbing.....	85
1118-AG Plumbing.....	86-87
17-601/17-835 15' Boom	86-91
17-601 1102/1104 Plumbing.....	92
17-601 1105 Plumbing.....	93
1115-AG Plumbing.....	94-95
1105/1108 Nozzle Assembly.....	96-97
Standard Nozzle Assembly.....	98
1115-AG/1118-AG Nozzle Assembly	99
Accessories	100-124
15-835 Tank Rinsing System.....	100
10-821 Water Fill Meter Kit.....	101
15-967 Hose Reel Mount.....	102
16-129 Hose Reel.....	103
16-906 Electric Hose Reel.....	104-105
Electric Hose Reel Wiring.....	106
Hose Reel Adjustments	107
Hose Reel Plumbing.....	108-109
30-006 Fresh Water Wash Tank	110
15-965 Foam Marker Kit	111-115
14-291Foamer	116-117
15-968 20 Gallon Rinse Tank	118-119
10-417 Chemical Cleanload®.....	120-121
15-620 Chemical Cleanload® Eductor	122-123
Chemical Cleanload Instructions.....	124
Reference	125-126
Decal List.....	125
Quick Reference Replacement Parts	126
Warranty	

Thank you for purchasing a **Smithco** product.

Read this manual and all other manuals pertaining to the Spray Star 1110 carefully as they contain safety, operating, assembly and maintenance instructions. Failure to do so could result in personal injury or equipment damage.

Keep manuals in a safe place after operator and maintenance personnel have read them. Right and left sides are from the operator's seat, facing forward.

WARNING

Failure to follow cautious operating practices can result in serious injury to the operator or other persons. The owner must understand these instructions, and must allow only trained persons who understand these instructions to operate this vehicle.

All **Smithco** machines have a Serial Number and Model Number. Both numbers are needed when ordering parts. The serial number plate on the Spray Star 1110 is located on the right hand frame rail. Refer to engine manual for placement of engine serial number. Refer to engine manual for placement of engine serial number.

For product and accessory information, help finding a dealer, or to register your product please contact us at www.Smithco.com.

Information needed when ordering replacement parts:

1. Model Number of machine
2. Serial Number of machine
3. Name and Part Number of part
4. Quantity of parts

For easy access record your Serial and Model numbers here.

SMITHCO			CE
WAYNE, PENNSYLVANIA 19087 USA 610-688-4009 Fax 610-688-6069			
SERIAL NO.	kW/hp	DATE OF MFG.	
<input type="text"/>	<input type="text"/>	<input type="text"/>	
MODEL NO.	lb/kg Empty	lb/kg Full	
<input type="text"/>	<input type="text"/>	<input type="text"/>	

SMITHCO CUSTOMER SERVICE 1-800-891-9435

SAFE PRACTICES

1. It is your responsibility to read this manual and all publications associated with this machine.
2. Never allow anyone to operate or service the machine or its optional equipment without proper training and instructions. Never allow minors to operate any equipment.
3. Learn the proper use of the machine, the location and purpose of all the controls and gages before you operate the equipment. Working with unfamiliar equipment can lead to accidents.
4. Wear all the necessary protective clothing and personal safety devices to protect your head, eyes, ears, hands and feet. Operate the machine only in daylight or in good artificial light.
5. Inspect the area where the equipment will be used. Pick up all debris you can find before operating. Beware of overhead obstructions and underground obstacles. Stay alert for hidden hazards.
6. Never operate equipment that is not in perfect working order or without decals, guards, shields, or other protective devices in place.
7. Never disconnect or bypass any switch.
8. Carbon monoxide in the exhaust fumes can be fatal when inhaled, never operate a machine without proper ventilation.
9. Fuel is highly flammable, handle with care.
10. Keep engine clean. Allow the engine to cool before storing and always remove the ignition key.
11. Disengage all drives and set park brake before starting the engine.
12. Never use your hands to search for oil leaks. Hydraulic fluid under pressure can penetrate the skin and cause serious injury.
13. This machine demands your attention. To prevent loss of control or tipping of the vehicle:
 - A. Use extra caution in backing up the vehicle. Ensure area is clear.
 - B. Do not stop or start suddenly on any slope.
 - C. Reduce speed on slopes and in sharp turns. Use caution when changing directions on slopes.
 - D. Stay alert for holes in the terrain and other hidden hazards.
14. Before leaving operator's position:
 - A. Disengage all drives.
 - B. Set park brake.
 - C. Shut engine off and remove the ignition key.
 - D. If engine has to run to perform any maintenance keep hands, feet, clothing and all other parts of body away from moving parts.
15. Keep hands, feet and clothing away from moving parts. Wait for all movement to stop before you clean, adjust or service the machine.
16. Keep the area of operation clear of all bystanders.
17. Never carry passengers.
18. Stop engine before making repairs/adjustments or checking/adding oil to the crankcase.
19. Use parts and materials supplied by **Smithco** only. Do not modify any function or part.
20. Use caution when booms are down as they extend out beyond the center line of the machine.
21. The tank is a confined space, take precaution.

These machines are intended for professional maintenance on golf courses, sports turf, and any other area maintained turf and related trails, paths and lots. No guaranty as to the suitability for any task is expressed or implied.



SPECIFICATIONS SPRAY STAR 1110

WEIGHTS AND DIMENSIONS

Length	130" (3.30m) with Boom	117" (2.97m) without Boom
Width	71" (1.8m)	
Height With 18' Boom	84" (2.1m)	
Height	75" (1.9m)	
Wheel Base	56" (1.4m)	
Weight Empty	1676lbs (760 kg)	
Weight Full	2592lbs (1175 kg)	

SOUND LEVEL (DBA)

At ear level	84.5 dba
--------------	----------

ENGINE

Make	Briggs & Stratton
Model#	386447
Type / Spec#	0459 G1
Horsepower	23HP (17 kw)
Fuel	Unleaded 87 Octane Gasoline Minimum
Cooling System	Air Cooled
Lubrication System	Full Pressure
Alternator	25 Amp

WHEELS & TIRE

Front:	Two 20 x 10.00 x 10 NHS Smooth; 20psi (1.4 bar)
Rear:	Two 24 x 13.00 x 12 NHS Multi-Trac; 20psi (1.4 bar)

PARK BRAKE

Hand Operated Lever, Discs on Rear Axle

SPEED

Forward Speed	0-8 mph (0-12.8 kph)
Reverse Speed	0-3 mph (0-4.8 kph)

BATTERY

	Automotive type 24F-12 Volt
BCI Group	Size 24
Cold Cranking Amps	575 minimum
Ground Terminal Polarity	Negative (-)
Maximum Length	10.25" (26 cm)
Maximum Width	6.88" (17 cm)
Maximum Height	10" (25 cm)

FLUID CAPACITY

Crankcase Oil	See Engine Manual
Fuel	6 gallon (22.7 liters)
Hydraulic Fluid	5 gallon (19 liters)
Grade of Hydraulic Fluid	SAE 10W-40 API Service SJ or higher Motor Oil

OPTIONAL EQUIPMENT

10-417	Chemical Clean-load Safe Fill System	17-601	15' HD Boom - 20" Spacing
15-968	20 Gal. Wash System	17-835	15' HD Boom - 10" Spacing
30-006	Fresh Water Tank	17-585	18' HD Boom
10-821	Water Meter Kit	15-965	Foam Marker
15-622	Canopy	15-835	Tank Rinsing System
15-967	Hose Reel Mount Kit		
16-129	Manual Rewind Hose Reel, 200-foot/61-meter capacity		
16-906	Electric Rewind Hose Reel, 200-foot/61-meter capacity		



MAINTENANCE

⚠ CAUTION

Before servicing or making adjustments to machine, stop engine and remove key from ignition.

⚠ IMPORTANT

Use all procedures and parts prescribed by the manufacturer's. Read the engine manual before operation.

LUBRICATION

Use No. 2 General purpose lithium base grease and lubricate every 100 hours. The Spray Star 1110 has 7 lube points.

- A. One on the rod end of hydraulic cylinder.
- B. One on each the right and left spindles.
- C. One on the reverse pedal.
- D. One on each end of tie rod.
- E. One on the forward pedal.

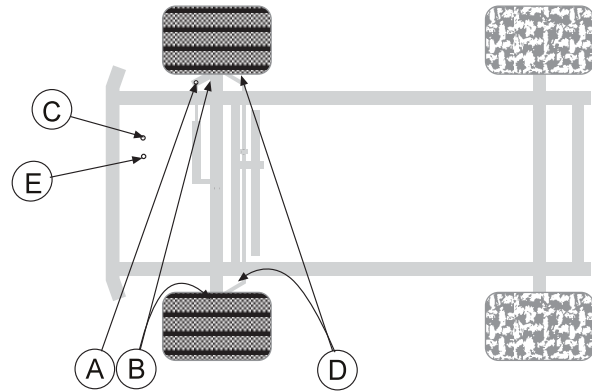

ELECTRICAL CONNECTIONS

Use dielectric grease on all electrical connections.

AIR CLEANER

1. Loosen cover retaining snaps and remove cover.
2. Remove pre-cleaner from paper element.
3. Check paper element. Replace element as necessary.
4. Wash pre-cleaner in warm water with detergent. Rinse pre-cleaner thoroughly until all traces of detergent are eliminated. Squeeze out excess water (do not wring). Allow pre-cleaner to air dry.
5. Saturate pre-cleaner with new engine oil. Squeeze out all excess oil.
6. Reinstall pre-cleaner over paper element.
7. Reinstall air cleaner cover. Secure cover with cover retaining knob.

WHEEL MOUNTING PROCEDURE

1. Set park brake. Turn machine off and remove key.
2. Block wheel on opposite corner.
3. Loosen nuts slightly on wheel to be removed.
4. Jack up machine being careful not to damage underside of machine.
5. Place wheel on hub lining up bolt holes.
6. Torque to 64-74 ft/lb (87-100Nm) using a cross pattern. Re-torque after first 8 hours and every 250 hours thereafter.
7. Lower machine to ground and remove blocks and jack.

TIRE PRESSURE

Caution must be used when inflating a low tire to recommended pressure. Over inflating can cause tires to explode. All tires should be 20 psi (1.4bar). Improper inflation will reduce tire life considerably.

ENGINE OIL

Change and add oil according to chart below. Do not overfill. Engine oil capacity is 2 quarts. We recommend high-quality detergent oils classified for service SF, SG, SH, SJ or higher. Do not use special additives. Outdoor temperatures determine the proper oil viscosity for the engine. Use the chart to select the best viscosity for the outdoor temperature range expected

SAE VISCOSITY GRADES

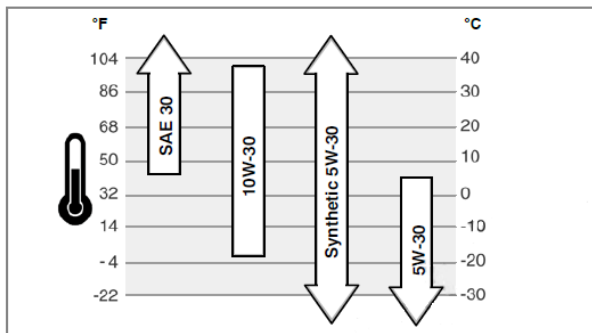

Use of multi-viscosity oils (10W-30, etc.) above 80° F (27° C) will result in high oil consumption and possible engine damage. Check oil level more frequently if using these types of oils.

SAE 30 oil, if used below 40° F (4° C), will result in hard starting and possible engine bore damage due to inadequate lubrication.

HYDRAULIC OIL

1. Use SAE 10W-40 API Service SJ or higher motor oil.
2. For proper warranty, change oil every 500 hours or annually, whichever ever is first. Change the filter after the first 50 hours, then every 250 hours thereafter.
3. Oil level should be 2-2½" (5-6.4cm) from top of the tank when fluid is cold. Do not overfill.
4. After changing oil, run the machine for a few minutes. Check oil level and for leaks.
5. Always use extreme caution when filling hydraulic oil tank or checking level to keep system free of contaminants. Check and service more frequently when operating in extremely cold, hot or dusty conditions.
6. If the natural color of the fluid has become black or smells burnt, it is possible that an overheating problem exists.
7. If fluid becomes milky, water contamination may be a problem.
8. If either of the above conditions happen, change oil immediately after fluid is cool and find the cause. Take fluid level readings when the system is cold.
9. In extreme temperatures you can use straight weight oil. We recommend SAE 30W API Service SG when hot (above 90°F (33°C)) and SAE 10W API Service SJ or higher when cold (below 32°F (0°C) ambient temperature. Use either motor oil or hydraulic oil, but do not mix.
10. Oil being added to the system must be the same as what is already in the tank. Mark the tank fill area as to which type you put in.

MAINTENANCE

BATTERY

Batteries normally produce explosive gases which can cause personal injury. Do not allow flames, sparks or any ignited object to come near the battery. When charging or working near battery, always shield your eyes and always provide proper ventilation.

Battery cable should be disconnected before using "Fast Charge".

Charge battery at 15 amps for 10 minutes or 7 amps for 30 minutes. Do not exceed the recommended charging rate. If electrolyte starts boiling over, decrease charging.

Always remove grounded (-) battery clamp first and replace it last. Avoid hazards by:

1. Filling batteries in well-ventilated areas.
2. Wear eye protection and rubber gloves.
3. Avoid breathing fumes when electrolyte is added.
4. Avoid spilling or dripping electrolyte.

⚠ WARNING

Battery Electrolyte is an acidic solution and should be handled with care. If electrolyte is splashed on any part of your body, flush all contact areas immediately with liberal amounts of water. Get medical attention immediately.

⚠ WARNING

Use of booster battery and jumper cables. Particular care should be used when connecting a booster battery. Use proper polarity in order to prevent sparks.

TO JUMP START (NEGATIVE GROUNDED BATTERY):

1. Shield eyes.
2. Connect ends of one cable to positive (+) terminals of each battery, first (A) then (B).
3. Connect one end of other cable to negative (-) terminal of "good" battery (C).
4. Connect other end of cable (D) to engine block on unit being started (NOT to negative (-) terminal of battery)

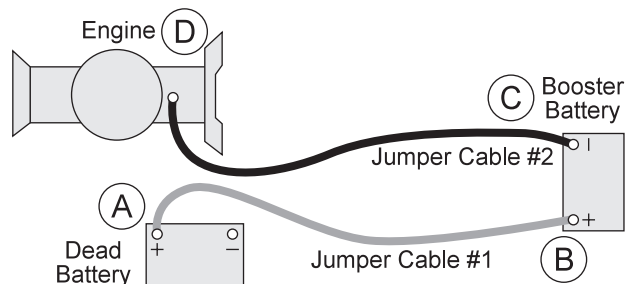

To prevent damage to other electrical components on unit being started, make certain that engine is at idle speed before disconnecting jumper cables.

STORAGE

If the engine will be out of service for two or more months, use the following storage procedure.

1. Clean the exterior surfaces of the engine.
2. Change the oil and filter while the engine is still warm from operation.
3. The fuel system must be completely emptied, or the gasoline must be treated with a stabilizer to prevent deterioration.

If you choose to use a stabilizer, follow manufacturers recommendations, and add the correct amount for the capacity of fuel system. Fill fuel tank with clean, fresh gasoline. Run engine for 2-3 minutes to get stabilized fuel into carburetor. Close fuel shut-off valve when unit is being stored or transported.

To empty the system, drain fuel tank and carburetor, or run engine until tank and system are empty.

4. Remove the spark plugs. Add one tablespoon of engine oil into each spark plug hole. Install plugs, but do not connect the plug leads. Crank the engine two or three revolutions.
5. Store machine in a clean, dry place.

SERVICE CHART

⚠ CAUTION

Before servicing or making adjustments to the machine, stop engine, set park break, block wheels and remove key from ignition.

⚠ IMPORTANT

Follow all procedures and **ONLY** use parts prescribed by the manufacturer. Read the engine manual before maintenance.

Maintenance Service Interval	Maintenance Procedure
After the first 8 operating hours	Torque the wheel lug nuts. (64-74 ft/lb (87-100 Nm))
	Change the engine oil filter.
Before each use daily	Check the engine oil level.
	Clean area around muffler and controls.
	Check the hydraulic fluid level.
	Check the tire pressure.
	Check condition of hydraulic hoses and fittings.
	Inspect and clean the machine.
After the first 50 hours	Change Hydraulic Oil Filter.
Every 100 hours	Clean or change air filter. ¹
	Clean pre-cleaner. ¹
	Change engine oil and filter.
	Replace spark plug .
	Lubricate machine.
	Clean or change remote air cleaner.
	Check the battery fluid level and cable connections..
	Check muffler and spark arrestor.
Check belt tension .	
Every 250 hours	Check engine valve clearance and adjust if necessary.
	Check idle speed.
	Clean battery terminals.
	Change hydraulic oil filter.
	Torque the wheel lug nuts. (64-74 ft/lb (87-100 Nm))
Every 500 hours or yearly	Change fuel filter.
	Change hydraulic oil and filter.
	Clean oil cooler fins. ¹
	Clean air cooling system. ¹
	Check safety filter in remote air cleaner.
1 In dusty conditions or when airborne debris is present, clean more often.	

WHEEL CREEP

"Creep" is when the engine is running and hydrostatic transmission is in neutral, but due to inadequate alignment, wheels still move. Do the following procedure to stop this motion.

1. Lift up and support machine so rear wheels are off the ground and can turn freely.
2. On top of the pump there is a Creep arm. Loosen bolt (Ref A) on creep arm.
3. With engine running, adjust the 'creep arm' side to side so centering arm centers on the swash plate.
4. Tighten all fasteners and test by using foot pedal linkage to see that 'creep' is removed.
5. Turn engine off and lower machine.

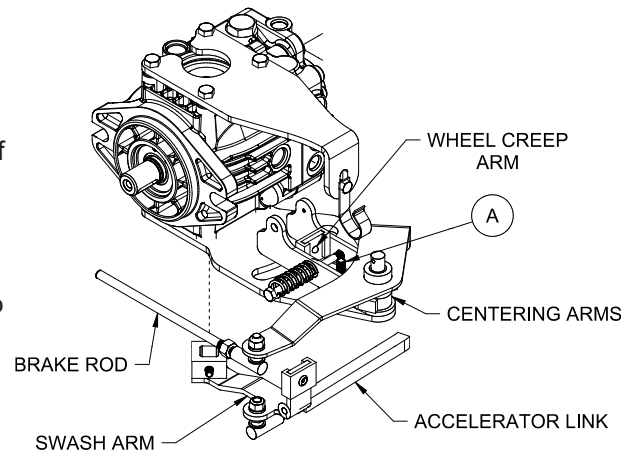

PARK BRAKE

Park brake (Ref B) is located on the right side of seat. Turn knob clockwise on end of park brake to tighten. Turn it counter clockwise to loosen. If finer adjustment is needed turn clevis on brake cable to adjust length of cable.

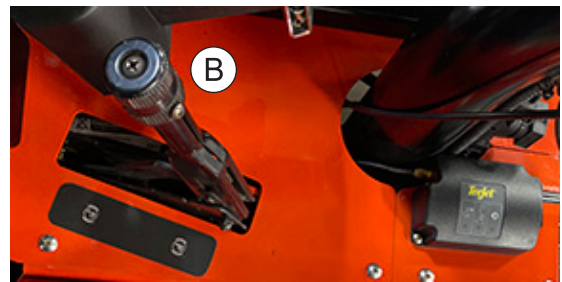

MASTER BOOM SWITCH (FOOT SWITCH)

The master boom switch (Ref C), located on the left floorboard is used to override the master switch on the computer console of the Radion 8140 spray system. By pushing down it will turn on/off the booms.



SPRAY BOSS CONTROL HANDLE

The spray boss control lever (Ref D), located on the left side of the seat, engages and disengages the speed boss. Forward is engage and all the way back is disengage. When the lever is engaged it sets a stop for the accelerator. The accelerator pedal must be used to maintain this speed. To adjust speed use the knob on the end of the lever, counter clockwise increases speed and clockwise decreases speed. Disengage the lever and you will have full accelerator pedal range.

CHOKE

The choke (Ref E) is used in starting the engine. Pull choke out to close choke plate when starting a cold engine. Push in when engine starts. A warm engine may not require "choking" to start.

SPRAY PUMP

The spray pump is located to the rear and right of the engine. The belt should have approximately 1/2" (13mm) of deflection in the center of the top strand. Loosen two bolts holding the pump in place. Slide pump to the desired tension. Tighten the bolts.

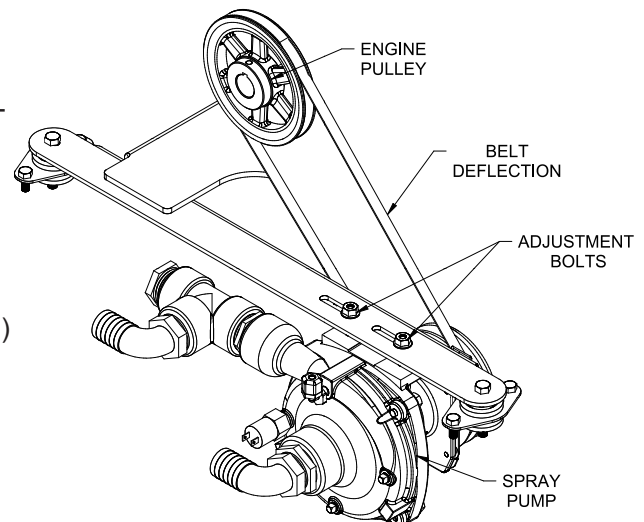

WIRING DIAGRAM

Use dielectric grease on all electrical connections.

Diagrams

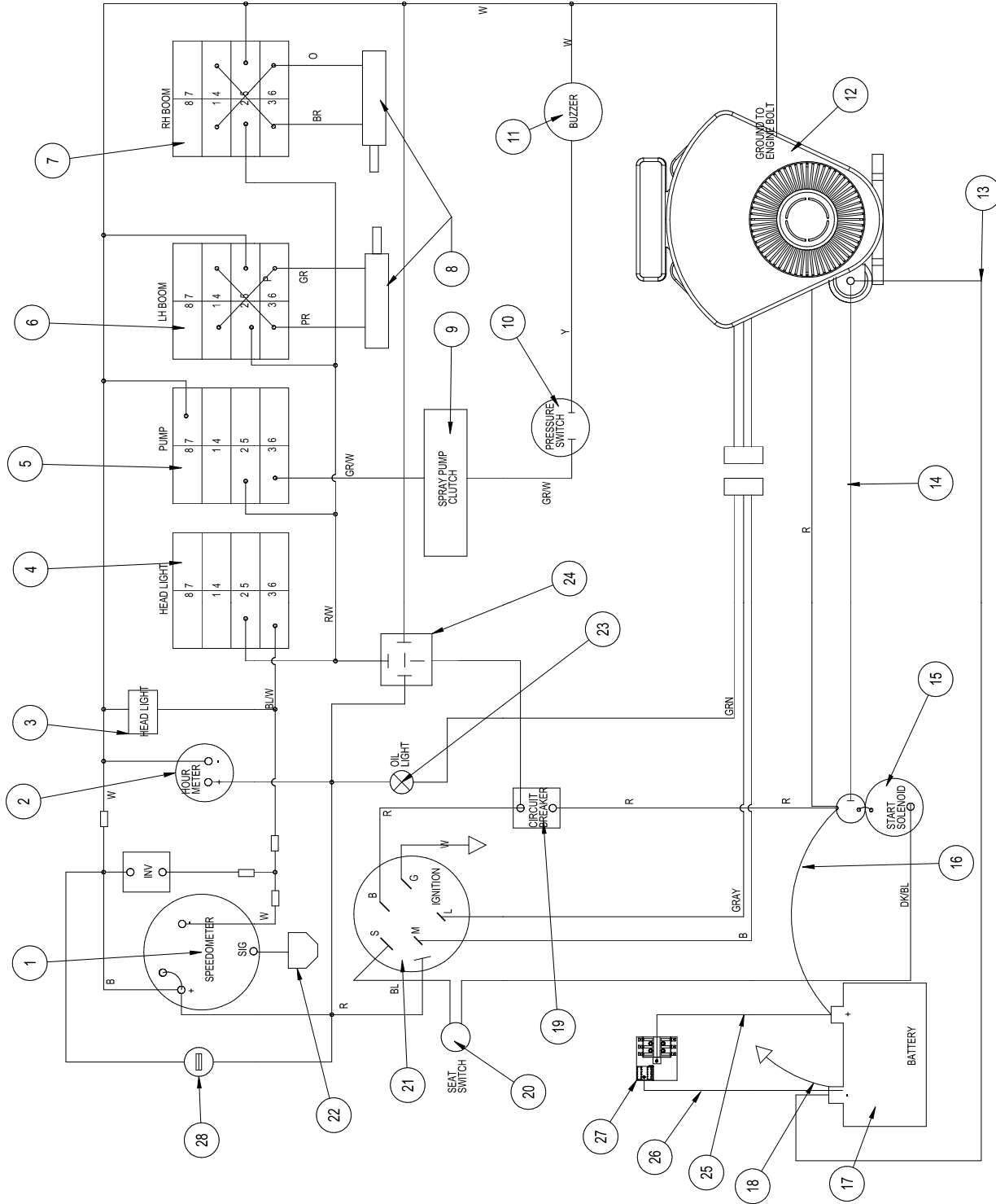

WIRING PARTS LIST

REF#	PART#	DESCRIPTION	QUANTITY
1	30-356	GPS Speedometer w/ connectors	1
2	12-804	Hour Meter	1
3	20-912	LED Head Light	2
4	Head Light		
	15-729	Mount Panel Middle	1
	15-727	Rocker, No Light	1
	15-782	Non-Lighted Switch	1
5	Pump		
	15-729	Mount Panel Middle	1
	15-726	Lighted Switch	1
	15-731	Rocker, Amber	1
6	Left Boom		
	15-729	Mount Panel Middle	1
	15-727	Rocker, No Light	1
	15-728	Centering Switch Momentary, On-Off-On	1
7	Right Boom		
	15-725	Mount Panel End	1
	15-727	Rocker, No Light	1
	15-728	Centering Switch Momentary, On-Off-On	1
8	30-214	Electric/Hydraulic Actuators	2
9	15-984	Hypro Pump With Electric Clutch	1
10	33-480	Pressure Switch	1
11	77-207	Buzzer	1
	8874	Female Bullet	1
	8875	Male Bullet	1
	8963	Heat Shrink	2
12	10-753	Briggs, 23HP Engine	1
13		Black Cable	1
14	22-017	Starter Cable	1
15		Starter Solenoid	1
16	75-518	Red Battery Cable	1
	45-416	Battery Boot	1
17	33-216	Battery	1
18	76-327	Ground Battery Cable	1
19	77-261	Circuit Breaker	1
	8977	Circuit Breaker Boot	1
20	14-292	Seat Switch	1
21	13-488	Replacement Ignition Switch	1
22	20-730-01	Antenna (comes with Speedometer)	1
23	50-359	Oil Warning Light	1
	8853	Slide On Connector	1
	8958	Male Spade	1
	8963	Heat Shrink	2
24	30-042-06	Relay	1
25	8919	10GA Red Wire	39"
	8928	⁵ / ₁₆ Ring terminal	1
	8912	³ / ₁₆ Ring Terminal	1
	8963	Heat Shrink	2
26	8931	10GA White Wire	46"
	8928	⁵ / ₁₆ Ring terminal	1
	8912	³ / ₁₆ Ring Terminal	1
	8963	Heat Shrink	2
27	33-271	Fuse Panel	1
28	32-576	USB Charger	1
	10-780	Chassis Wire Harness	1
	10-756	Engine Wire Harness	1

To reset circuit breaker on ball valve, you must disconnect power to computer.

HYDRAULIC DIAGRAM

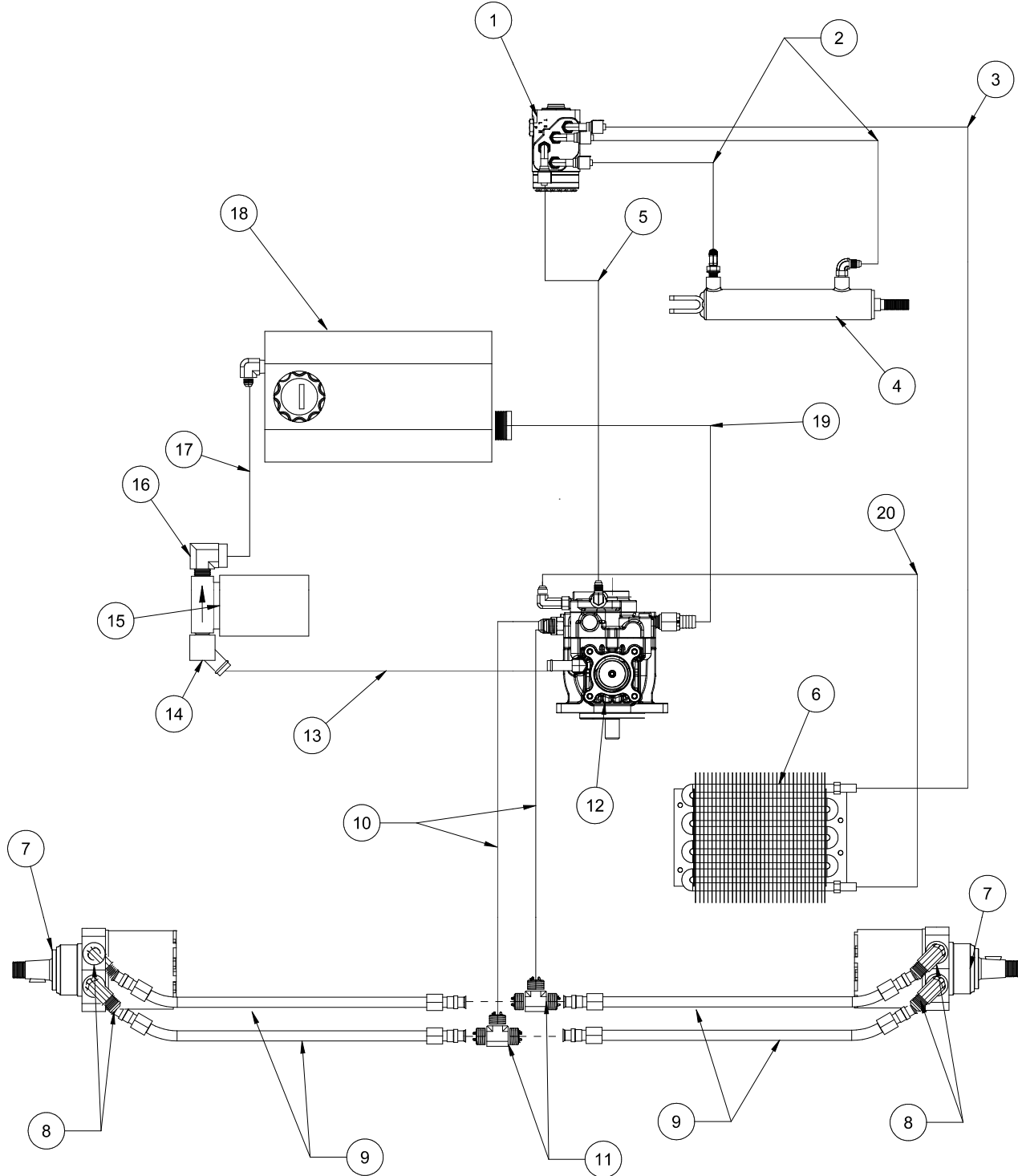

HYDRAULIC PRESSURES

Piston Pump Displacement	.913 in ³
Pump Input Speed (up to)	3600 rpm
Max. Operating Pressure	3000 peak psi
Implement Setting	345 psi
13-729 Hydraulic Valve (2 bank)	900 psi

Charge Pump Displacement	.33 in ³ /rev
Max. Inlet Vacuum	5 in. Hg
Max. Case Pressure	25 psi
Relief Valve Pressure (set at)	1200 psi

HYDRAULIC DIAGRAM PARTS LIST

REF#	PART#	DESCRIPTION	QUANTITY
1	15-301	Orbital	1
	18-169	³ / ₈ Adapter Fitting	4
2	10-671	Hydraulic Hose x 65"	2
3	10-790	Hydraulic Hose x 68"	1
4	77-263	Hydraulic Cylinder	1
	18-168	³ / ₈ Street Elbow	2
5	10-791	Hydraulic Hose x 64"	1
6	45-382	Oil Cooler	1
7	10-510	Wheel Motor	2
8	34-122	Short Elbow	4
9	20-656	Hydraulic Tube Assembly	4
10	10-789	Hydraulic Hose x 54.5"	2
11	34-057	Tee, 1"	2
12	45-373	DDC Piston Pump	1
13	8917	⁵ / ₈ " Suction Hose	21"
	18-040	Hose Clamp	2
14	18-106	³ / ₄ x 45° Elbow	1
15	26-016	Oil Filter	1
	23-031	Filter Element, 25 Micron	1
16	18-140	90° Street Elbow	1
17	8917	⁵ / ₈ " Suction Hose	18"
	18-040	Hose Clamp	2
18	60-473	Oil Tank	1
19	8832	³ / ₄ " Suction Hose	16"
	18-040	Hose Clamp	2
20	10-788	Hydraulic Hose x 21"	1

Diagrams

FITTING TORQUE CHARTS

SAE Straight Thread O-ring Plugs (Steel)						Seal-Lok Straight and Adjustable Fitting (Steel)			
Fitting Size	SAE Port Thread	Hollow Hex Head Plug (HP50N) Assembly Torque		Hex Head Plug (P50N) Assembly Torque		Fitting Size	SAE Port Thread Size	Assembly Torque (2)	
		in. lbs	ft. lbs	in. lbs	ft. lbs			in. lbs	ft. lbs
2	5/16 - 24	35 ± 5	3 ± .5	90 ± 5	7.5 ± .5	4	7/16 - 20	190 ± 10(1)	16 ± 1.0
3	3/8 - 24	60 ± 5	5 ± .5	170 ± 10	14 ± 1	6	9/16 - 18	420 ± 15	35 ± 1.0
4	7/16 - 20	135 ± 10	11 ± 1	220 ± 15	18 ± 1	8	3/4 - 16	720 ± 25	60 ± 2.0
5	1/2 - 20	180 ± 10	15 ± 1	260 ± 15	22 ± 1	10	7/8 - 14	1260 ± 50	105 ± 5.0
6	9/16 - 18	220 ± 10	18 ± 1	320 ± 20	27 ± 2	12	1 1/16 - 12	1680 ± 75	140 ± 6.0
8	3/4 - 16	550 ± 20	46 ± 2	570 ± 25	48 ± 2	16	1 5/16 - 12	2520 ± 100	210 ± 8.0
10	7/8 - 14	900 ± 50	75 ± 5	1060 ± 50	90 ± 5	20	1 5/8 - 12	3100 ± 150	260 ± 12.0
12	1 1/16 - 12	1020 ± 50	85 ± 5	1300 ± 50	110 ± 5	24	1 7/8 - 12	3800 ± 150	315 ± 12.0
14	1 3/16 - 12	1550 ± 75	130 ± 6	1750 ± 75	145 ± 6				
16	1 5/16 - 12	1600 ± 75	135 ± 6	1920 ± 75	160 ± 6				
20	1 5/8 - 12	2700 ± 150	225 ± 12	2700 ± 150	225 ± 12				
24	1 7/8 - 12	3000 ± 150	250 ± 12	3000 ± 150	250 ± 12				
32	2 1/2 - 12	3900 ± 200	325 ± 15	3900 ± 200	325 ± 15				

Over tightened fittings will result in crushing the cone which will create a leak.

Charts Developed by Parker Hennipin

MAIN BODY DRAWING

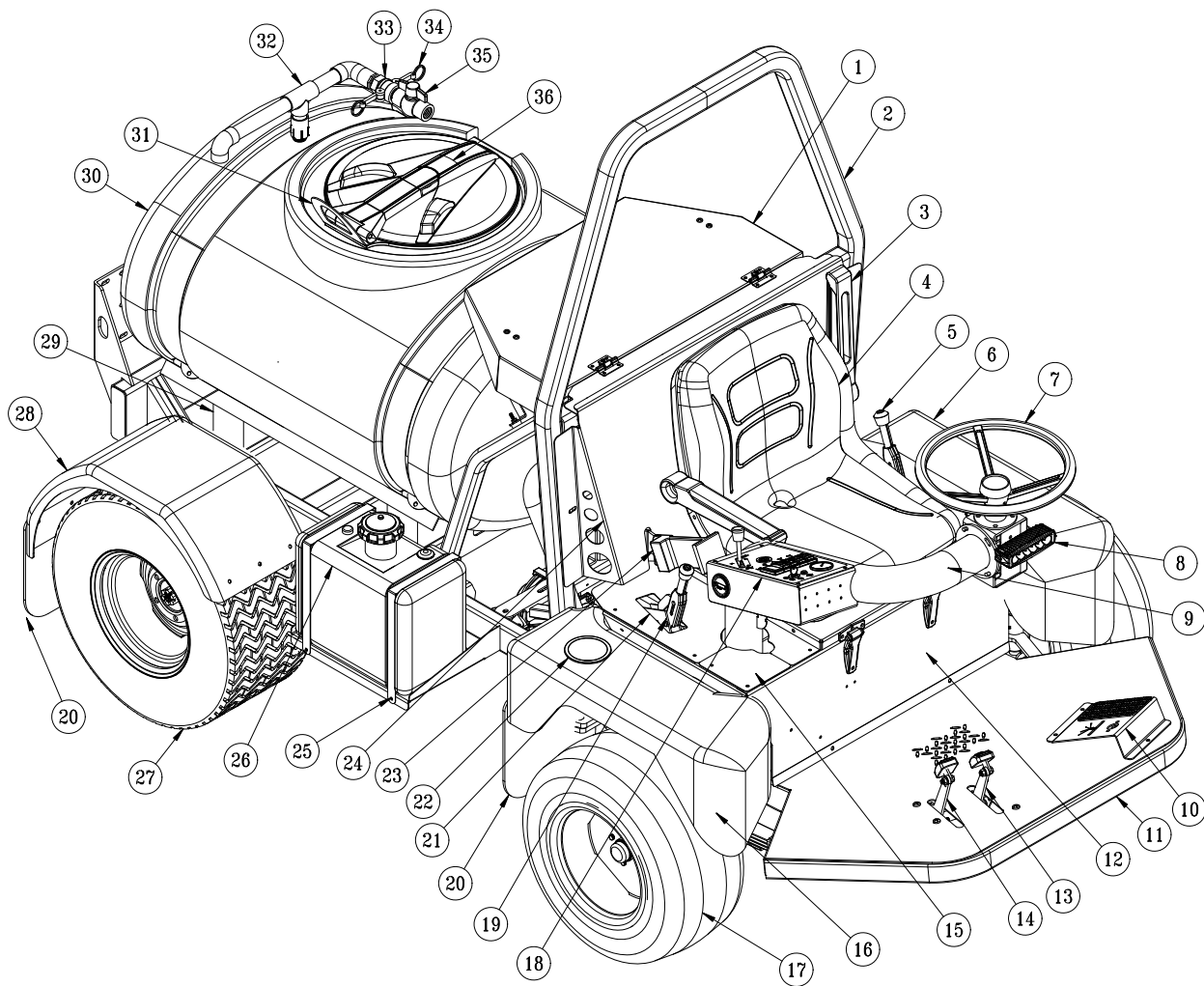

PARTS

MAIN BODY PARTS LIST

REF#	PART#	DESCRIPTION	QUANTITY
1	15-936	Engine Hood	1
2	20-886	Roll Bar	1
3	10-706	Arm Rest Kit	1
4	14-294	Seat Kit	1
	14-292	Seat Switch	1
	HB-516-18-125	Hex Bolt, $\frac{5}{16}$ - 18 x $1\frac{1}{4}$	4
	HW-516	Flat Washer, $\frac{5}{16}$	4
	HWL-516	Lock Washer, $\frac{5}{16}$	4
	HN-516-18	Hex Nut, $\frac{5}{16}$ - 18	4
5	10-120	Spray Boss Handle	1
6	30-405	Left Front Fender	1
7	21-498	Steering Wheel	1
	21-499	Center Cap	1
8	20-912	LED Head Light	1
9	10-683	Side Console Arm	1
10	45-047	Foot Rest (part of Spray System)	1
	45-132	Foot Rest Grip	1
11	10-800	Main Frame	1
12	10-680	Seat Frame	1
	20-730-01	GPS Speedometer Antenna	1
13	10-678	Reverse Pedal	1
	45-022	Molded Foot Pedal	1
14	10-677	Forward Pedal	1
	45-022	Molded Foot Pedal	1
15	10-694	RH Panel Cover	1
16	30-404	RH Front Fender	1
17	10-745	Tire and Wheel	2
	10-745--01	Tire, 20 x 10 - 10 Smooth	2
	16-857-02	Wheel	2
18	10-684	Control Panel	1
19	60-106	Park Brake Handle	1
20	20-659	Mud Flap	4
21	15-953	RH Control Panel	1
22	15-781	Drink Cup Holder	1
23	76-198-03	Seat Belt	1
24	15-934	Back Panel	1
	9023	Heat Reflective Matting (18 x 25.5)	1 Sheet
25	78-456	Gas Tank Strap	2
26	15-838	Fuel Tank	1
27	16-225	Tire and Wheel	2
	16-225-01	Tire, 24-13-12NHS	2
	16-225-02	Wheel	2
28	20-958	Rear Fender - orange	2
	HBCL-516-18-100	Carriage Bolt, $\frac{5}{16}$ - 18 x 1	6
	HNFL-516-18	Flange-Loc Nut, $\frac{5}{16}$ - 18	6
29	10-112	Tank Carrier	1
30	10-111	110 Gallon Poly Tank	1
31	10-639	Lid Stop	1
32	10-759	Air Gap Filler	1
33	16-961	Adapter, 1"	1
34	16-962	Coupler, 1"	1
35	18-448	Ball Valve, 1"	1
36	14-532	Lid (comes with tank)	1
	16-169	Strainer Basket	1

ENGINE HOOD & ROLL BAR DRAWING

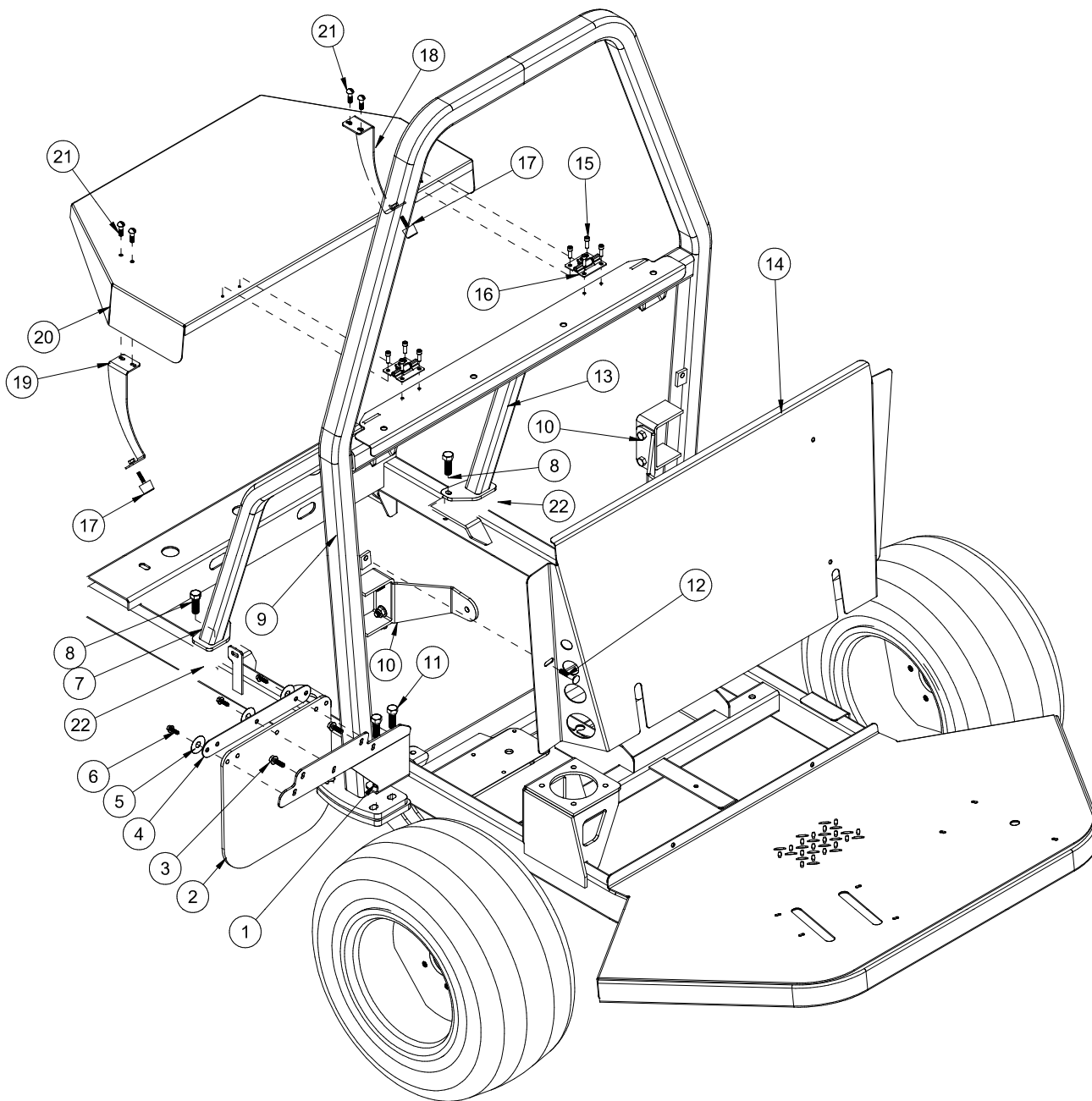

PARTS

ENGINE HOOD AND ROLL BAR PARTS LIST

REF#	PART#	DESCRIPTION	QUANTITY
1	15-940	RH Fender Brace	1
	15-939	LH Fender Brace (not shown)	1
2	20-659	Mud Flap	2
3	HBCL-516-18-100	Carriage Bolt, $\frac{5}{16}$ -18 x 1	4
	HNFL-516-18	Flange-Loc Nut, $\frac{5}{16}$ - 18	4
4	20-660	Mud Flap Strap	2
5	HWF-14-150	Fender Washer, $\frac{1}{4}$ x $1\frac{1}{2}$	6
6	HB-14-20-075	Hex Bolt, $\frac{1}{4}$ -20 x $\frac{3}{4}$	6
	HNFL-14-20	Flange-Loc Nut, $\frac{1}{4}$ - 20	6
7	20-888	RH Roll Bar Leg	1
8	HB-38-16-150	Hex Bolt, $\frac{3}{8}$ - 16 x $1\frac{1}{2}$	4
	HNTL-38-16	Lock Nut, $\frac{3}{8}$ - 16	4
9	20-886	Roll Bar	1
10	15-935	Seat Belt Bracket	2
	HB-38-16-150	Hex Bolt, $\frac{3}{8}$ - 16 x $1\frac{1}{2}$	4
	HNTL-38-16	Lock Nut, $\frac{3}{8}$ - 16	4
11	HB-12-13-175	Hex Bolt, $\frac{1}{2}$ - 13 x $1\frac{3}{4}$	10
	HW-12	Flat Washer, $\frac{1}{2}$	10
	HNTL-12-13	Lock Nut, $\frac{1}{2}$ - 13	10
12	HB-38-16-075	Hex Bolt, $\frac{3}{8}$ -16 x $\frac{3}{4}$	2
	HNFL-38-16	Flange-Loc Nut, $\frac{3}{8}$ -16	2
13	20-890	LH Roll Bar Leg	1
14	15-934	Back Panel	1
	9023	Heat Reflective Matting (18 x 25.5)	1 Sheet
15	HSM-10-32-063	Machine Screw, 10-32 x $\frac{5}{8}$	8
	HNFL-10-32	Flange-Loc Nut, 10 - 32	8
16	32-695	Adjustable Hinge	2
17	15-013	Rubber Bumper	2
	HNFL-14-20	Flange-Loc Nut, $\frac{1}{4}$ - 20	2
18	20-879	LH Hood Stand	1
19	20-880	RH Hood Stand	1
20	15-936	Engine Hood	1
21	HSTP-516-18-075	Truss Head Screw, $\frac{5}{16}$ -18 x $\frac{3}{4}$	4
	HNFL-516-18	Flange-Loc Nut, $\frac{5}{16}$ - 18	4
22	20-913	Roll Bar Spacer	2

CONTROL PANEL DRAWING

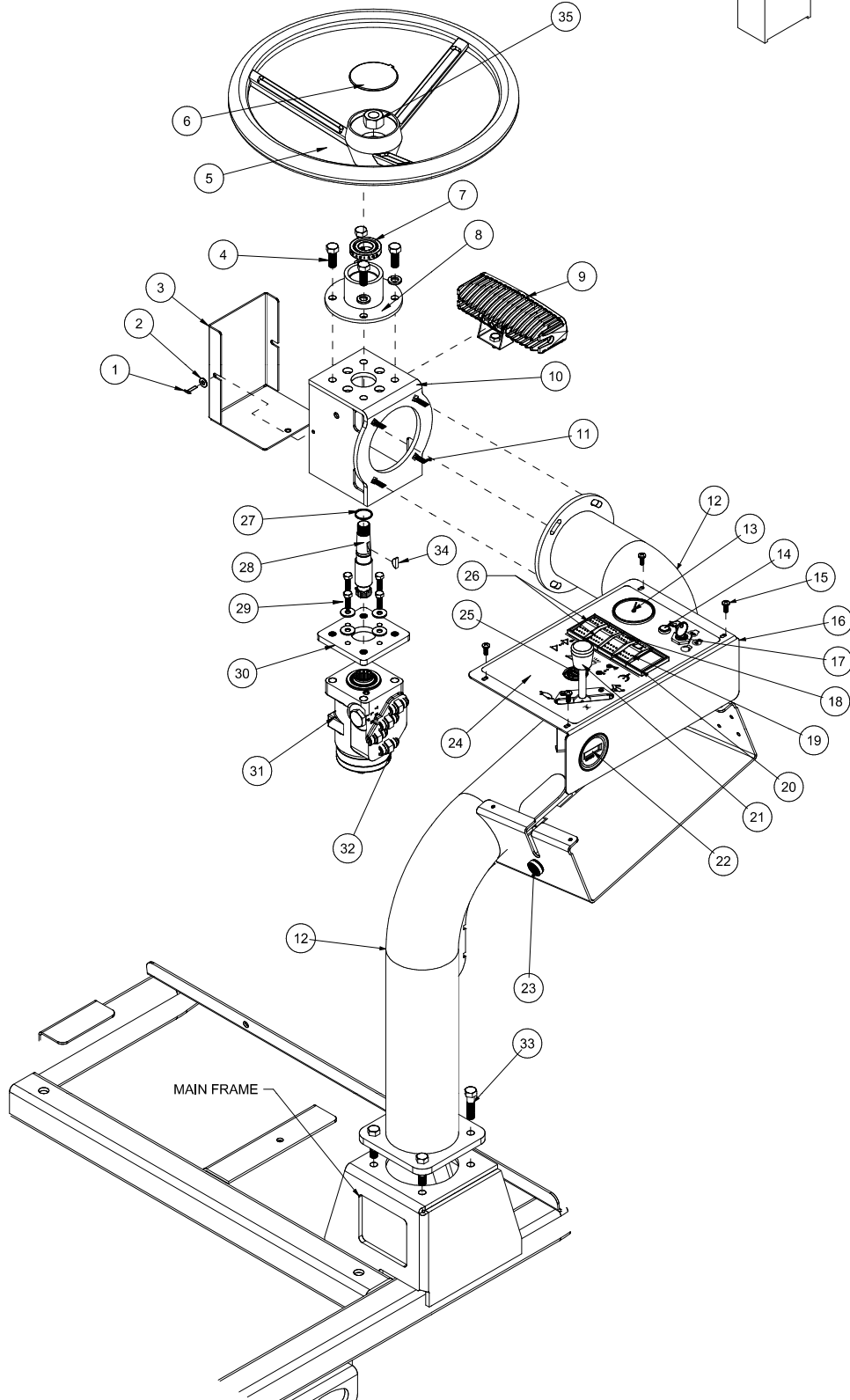
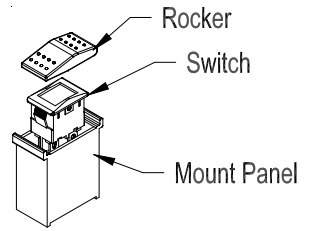

PARTS

CONTROL PANEL PARTS LIST

REF#	PART#	DESCRIPTION	QUANTITY
1	HSM-10-32-063	Machine Screw, #10 -32 x 5/8	2
2	HW-10	Flat Washer, #10	2
3	10-704	Steering Box Cover	1
4	HB-38-16-100	Hex Bolt, 3/8 -16 x 1	4
	HWL-38	Lock Washer, 3/8	4
5	21-498	Steering Wheel	1
6	21-499	Steering Wheel Cap	1
7	10-711	Ball Bearing	1
8	10-698	Steering Column	1
9	20-912	LED Head Light	1
10	10-682	Steering Box	1
11	HBCL-516-18-100	Carriage Bolt, 5/16 - 18 x 1	4
	HNFL-516-18	Flange-Loc Nut, 5/16 - 18	4
12	10-683	Side Control Arm	1
13	30-356	GPS Speedometer w/Connectors	1
14	50-359	Oil Warning Indicator Light	1
	8853	Female Spade Connector	1
	8958	Male Spade Connector	1
15	HSM-10-32-100	Machine Screw, #10 -32 x 1	4
	HNFL-10-32	Flange-Loc Nut, #10- 32	4
16	10-684	Control Panel	1
17	13-488	Replacement Ignition Switch	1
	8-709	Key Set	1
18	LED Head Light		
	15-727	Rocker	1
	15-729	Panel Mount Middle	1
	15-782	Switch, On-None-Off	1
19	Spray Pump		
	15-731	Amber Rocker	1
	15-729	Panel Mount Middle	1
	15-726	Lighted Switch	1
20	15-730	Panel Mount Plug	1
	15-725	Panel Mount End	1
21	76-528	Throttle Cable	1
	HSM-10-32-100	Machine Screw, #10-32 x 1	2
	HW-10	Washer, #10	2
	HNFL-10-32	Flange Whiz-loc Nut, #10-32	2
22	12-804	Hour Meter	1
23	77-207	Buzzer	1
	8875	Male Bullet	1
	8874	Female Bullet	1
24	10-657	Decal, Control Panel	1
25	32-576	Dual USB Power Charger	1
26	RH and LH Booms		
	15-725	Panel Mount End	1
	15-729	Panel Mount Middle	1
	15-727	Rocker	2
	15-728	Centering Switch, On-Off-On	2
27	HRR-075	Retaining Ring, 3/4"	1
28	10-825	Splined Tapered Steering Shaft	1
29	HBM-6-1-16	Metric Bolt, #6 - 1 x 16	4
	HWLM-6	Metric Lock Washer, M6	4
30	10-689	Orb Adapter	1
31	15-301	Orbital	1
32	18-169	3/8 Adapter Fitting	4
33	HB-38-16-100	Hex Bolt, 3/8-16-100	4
	HNFL-38-16	Flange-Loc Nut, 3/8-16	4
34	HWK-316-063	Woodruff Key, 3/16 x 5/8	1
35	HNJ-58-18	Jam Nut, 5/8- 18	1

FOOT PEDAL AND LINKAGE DRAWING

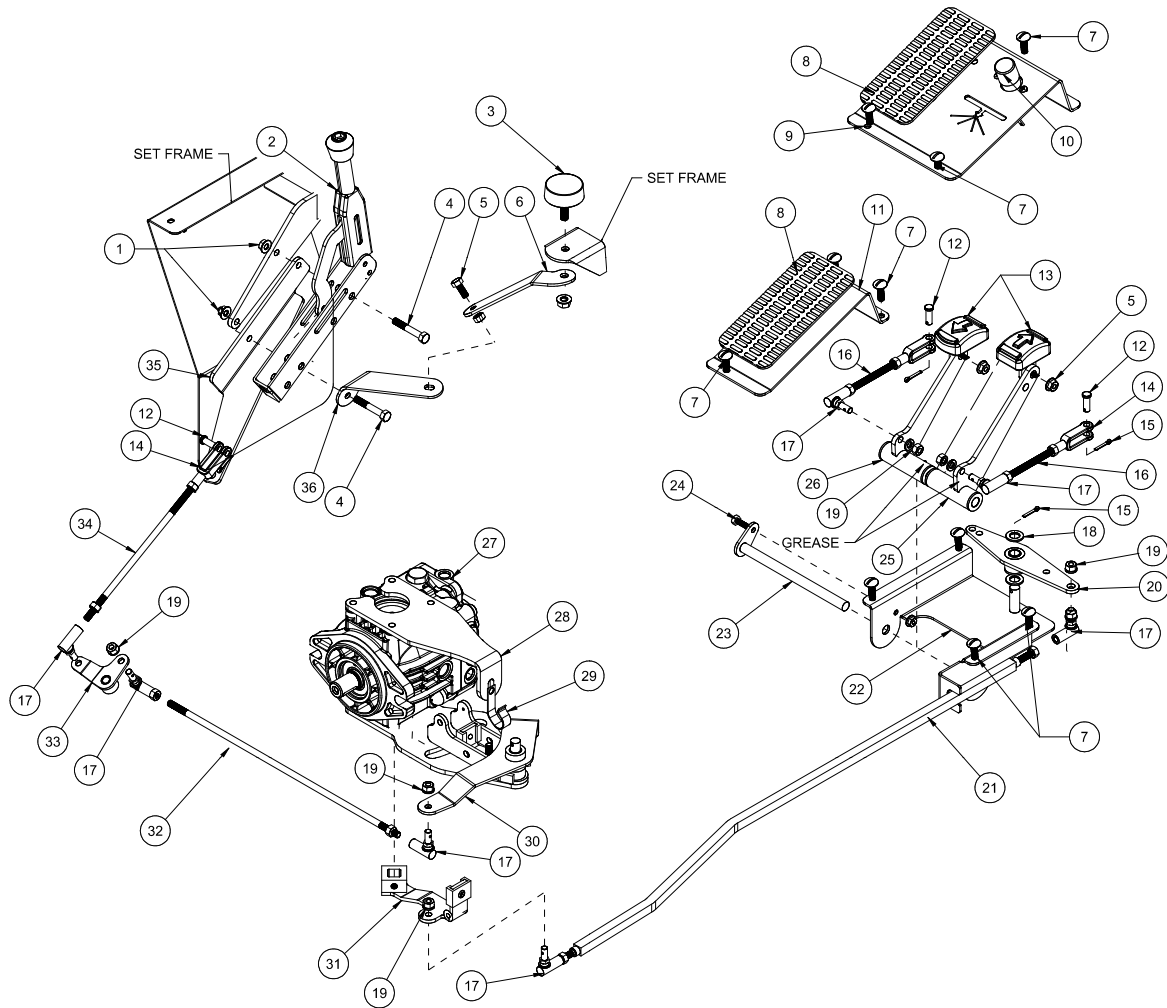

PARTS

FOOT PEDAL AND LINKAGE PARTS LIST

REF#	PART#	DESCRIPTION	QUANTITY
1	HNTL-516-18	Lock Nut, $\frac{5}{16}$ - 18	2
2	10-120	Spray Boss Handle	1
3	50-081	Rubber Bumper	2
	HNFL-38-16	Flange Whiz-loc Nut, $\frac{3}{8}$ - 16	2
4	HB-516-18-200	Hex Bolt, $\frac{5}{16}$ -18 x 2	2
5	HBFL-516-18-075	Flange Whiz-loc Bolt, $\frac{5}{16}$ -18 x $\frac{3}{4}$	3
	HNFL-516-18	Flange Whiz-loc Nut, $\frac{5}{16}$ -18	3
6	10-808	Upper Lever Brace	1
7	HSTP-516-18-075	Truss Head Screw, $\frac{5}{16}$ - 18 x $\frac{3}{4}$	7
	HNTL-516-18	Lock Nut $\frac{5}{16}$ - 18	7
8*	45-132	Foot Rest Grip	1
9*	10-705	Foot Rest (Radion System only)	1
10*	33-509	Spray Switch (Radion System only)	1
11*	45-047	Foot Rest	1
12	HCP-516-100	Clevis Pin, $\frac{5}{16}$ x 1	3
13	45-022	Molded Foot Pedal	2
14	11-100	Yoke, $\frac{5}{16}$ - 24	3
15	HP-18-100	Cotter Pin, $\frac{1}{8}$ x 1	4
16	10-598	Connector Rod	2
	HN-516-24	Hex Nut, $\frac{5}{16}$ - 24	4
17	21-462	Ball Joint, $\frac{5}{16}$ -24	7
18	HMB-12-14	Machine Bushing, $\frac{1}{2}$ x 14GA	2
19	HWL-516	Lock Washer, $\frac{5}{16}$	7
	HN-516-24	Hex Nut, $\frac{5}{16}$ - 18	7
20	15-924	Pedal Relay	1
21	10-797	Control Link	1
	HN-516-24	Hex Nut, $\frac{5}{16}$ - 18	2
22	10-674	Pedal Mount	1
23	10-673	Pedal Pivot	1
24	HB-14-20-075	Hex Bolt, $\frac{1}{4}$ - 20 x $\frac{3}{4}$	1
	HNFL-14-20	Flange Whiz-loc Nut, $\frac{1}{4}$ - 20	1
25	10-677	Forward Pedal Assembly	1
	76-128	Bushing	2
	HG-14-28-180	Grease Zerk	1
26	10-678	Reverse Pedal Assembly	1
	76-128	Bushing	2
	HG-14-28-180	Grease Zerk	1
27	45-373	DDC Piston Pump	1
28	10-804	Hose Brace	1
29	HLC-A-58	Loom Clamp. 5/8	1
30	10-801	Spray Boss Arm	1
31	10-799	Swash Arm	1
32	42-155	Brake Rod	1
	HN-516-24	Hex Nut, $\frac{5}{16}$ -24	2
33	10-802	Spray Boss Relay	1
34	43-220	Speed Boss Link	1
	HN-516-24	Hex Nut, $\frac{5}{16}$ -24	2
35	10-807	Spray Boss Relay Mount	1
36	10-809	Lower Lever Bracket	1

* Comes with Spray Systems.



FRONT AXLE DRAWING

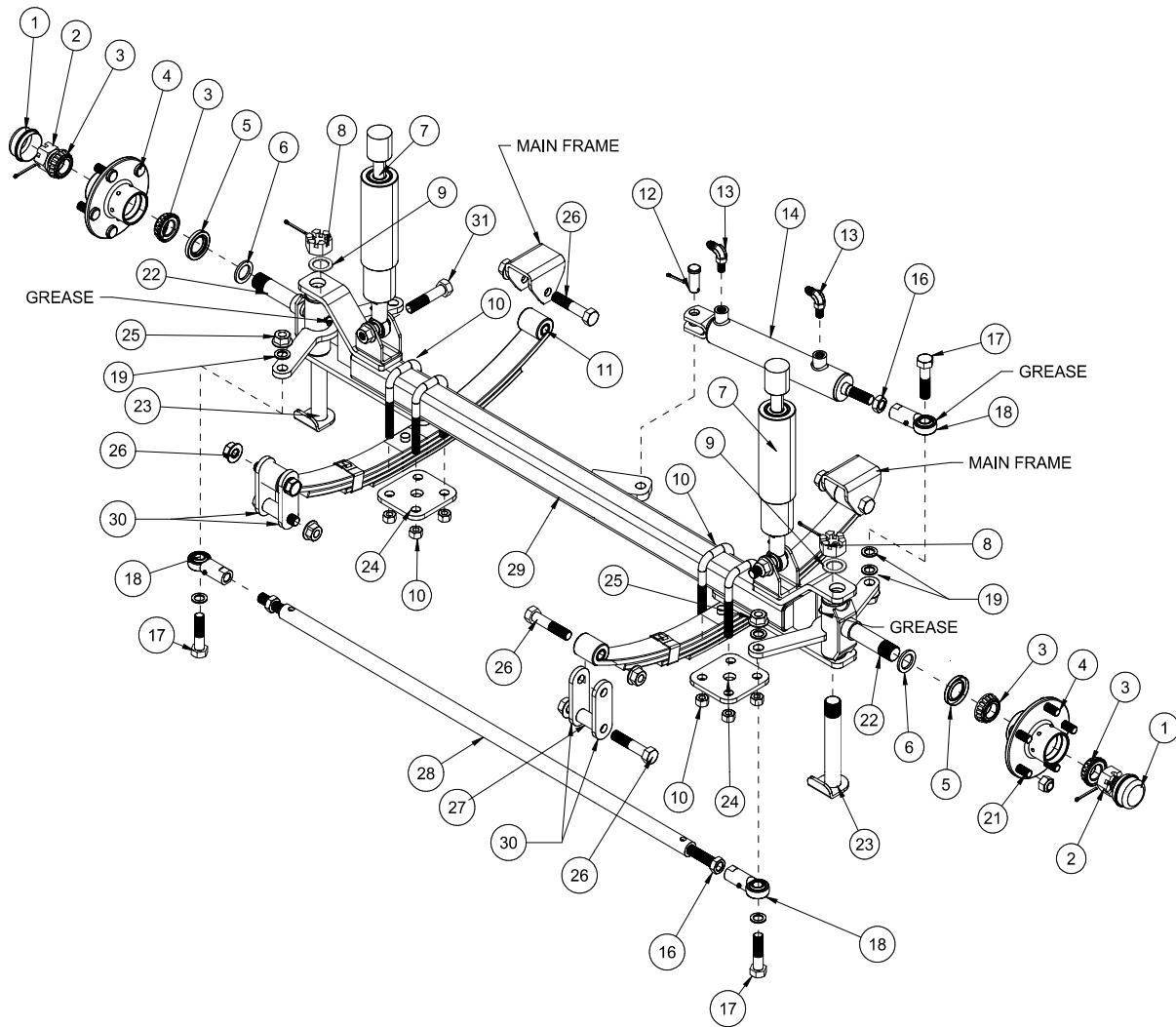

PARTS

FRONT AXLE PARTS LIST

REF#	PART#	DESCRIPTION	QUANTITY
1*	33-073-02	Dust Cap	2
2*	HNAR-100-14	Slotted Jam Nut, 1 - 14	2
	HP-18-150	Cotter Pin, 1/8 - 1 1/2	2
3*	11-043	Bearing	4
4	80-019	Hub (includes * items)	2
5*	11-041	Oil Seal	2
6	HMB-100-10	Machine Bushing, 1 x 10GA	2
7	20-617	Shock Absorbers	2
8	HNA-100-14	Slotted Nut, 1 - 14	2
	HP-18-150	Cotter Pin, 1/8 - 1 1/2	2
9	HMB-100-14	Machine Bushing, 1 x 14GA	2
10	20-555	U-bolt	4
	HNTL-12-13	Lock Nut, 1/2 - 13	8
11	20-740	Leaf Spring	2
12	HCP-58-175	Clevis Pin, 5/8 - 1 3/4	1
	HP-18-100	Cotter Pin, 1/8 x 1	1
13	18-168	90° Elbow	2
14	77-263	Hydraulic Cylinder	1
	14-530	Seal Kit	1
16	HNJ-58-18	Jam Nut, 5/8 - 18	3
17	HB-58-11-250	Bolt, 5/8 - 11 x 2 1/2	3
18	18-154	Rod End	3
	HG-14-28-180	Grease Fitting, 1/4 - 28 x 180°	3
19	HMB-58-14	Machine Bushing, 5/8 x 14GA	6
21*	60-268	Lug Bolt, 1/2 - 20-1 5/16	10
22	10-582	Spindle	2
	18-035	Bushing (part of Spindle; 2 per)	4
	HG-14-28-45	Grease Fitting, 1/4 - 28 x 45°	2
23	16-076	King Pin	2
24	20-538	Spring Mount	2
25	HNTL-58-11	Lock Nut, 5/8 - 11	3
26	HB-916-18-325	Hex Bolt, 9/16 - 18 x 3 1/4	6
	HNTL-916-18	Lock Nut, 9/16 - 18	6
27	30-251	Bushing (pressed in mainframe)	2
28	10-583	Steering Link	1
29	10-629	Front Axle	1
30	15-930	Spring Shackle	4
31	HB-58-11-300	Hex Bolt, 5/8 - 11 x 3	2
	HNTL-58-11	Lock Nut, 5/8 - 11	2

SEAT PANEL DRAWING

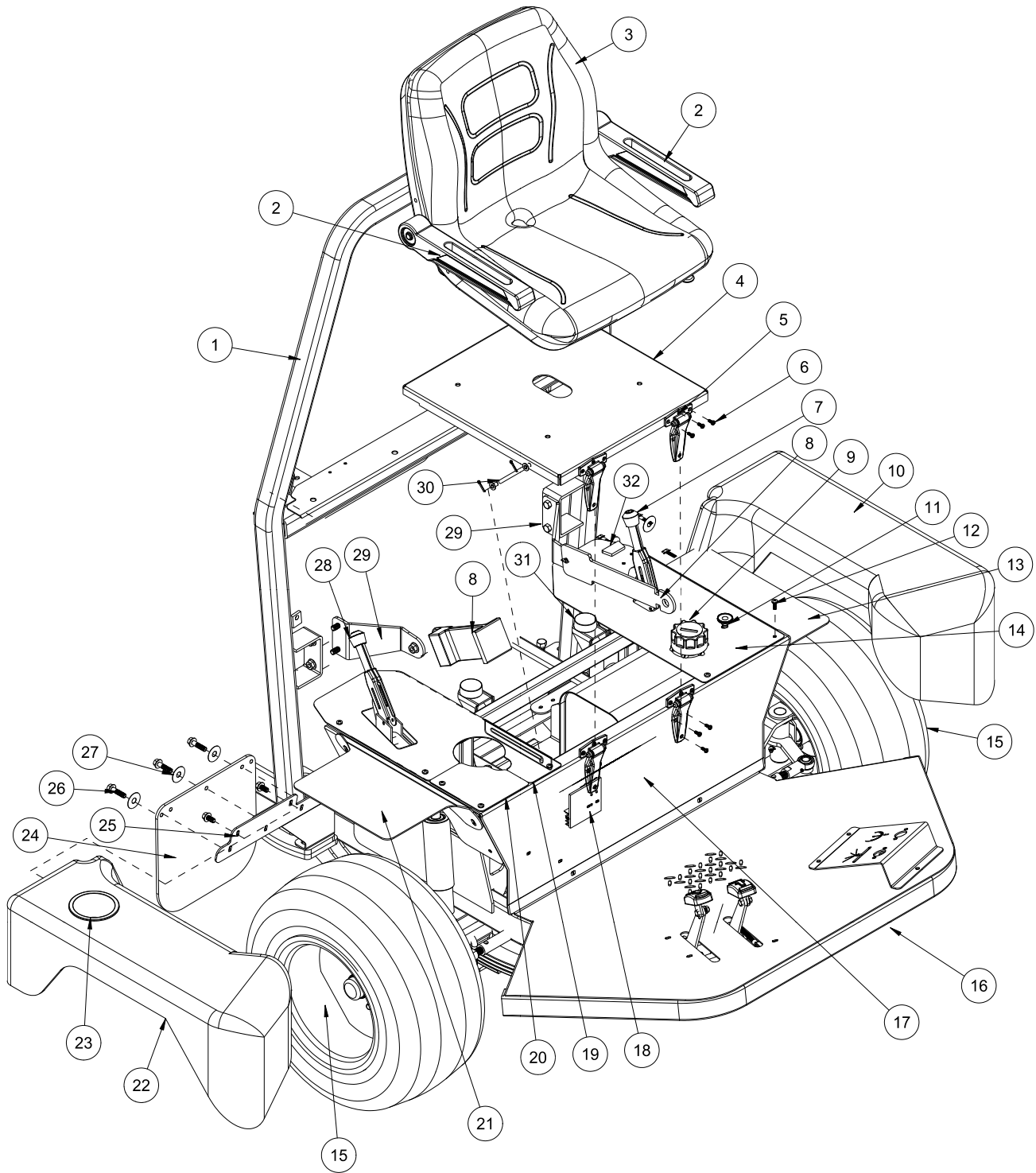

PARTS

SEAT CONSOLE PARTS LIST

REF#	PART#	DESCRIPTION	QUANTITY
1	20-886	Roll Bar	1
	HB-12-13-200	Hex Bolt, 1/2 - 13 x 2	8
	HW-12	Flat Washer, 1/2	8
	HNFL-12-13	Flange Whiz-loc Nut, 1/2 - 13	4
2	10-706	Arm Rest Kit	1
3	14-294	Seat Kit	1
	14-292	Seat Switch	1
	14-800	Seat Rail	1
	HB-516-18-125	Hex Bolt, 5/16 - 18 x 1 1/4	4
	HW-516	Flat Washer, 5/16	4
	HWL-516	Lock Washer, 5/16	4
	HN-516-18	Hex Nut, 5/16 - 18	4
4	10-714	Seat Panel	1
5	27-055	Hinge	2
6	HSMFCS-10-32-050	Machine Screw, #10-32-1/2	5
	HSMFCS-10-32-100	Machine Screw, #10-32-1	7
	HNFL-10-32	Flange-Loc Nut, #10-32	12
	HLC-A-58	Loom Clamp	1
7	10-120	Speed Boss Handle	1
8	76-198-03	Seat Belt	1
9	13-747	Filler Breather	1
	60-473	Oil Tank	1
10	30-405	LH Front Fender	1
11	80-020	Choke Cable	1
12	HSDPS-14-100	Pan Head Drill Screw, 1/4 x 1	8
13	10-823	LH Fender Bracket	1
14	15-954	LH Control Panel	1
15	16-857	Tire and Wheel	2
	16-857-01	Tire, 20 x 10 - 10NHS 4 Ply	2
	42-161-02	Wheel	2
16	10-800	Main Frame	1
17	10-680	Seat Frame	1
18	33-271	Fuse Panel	1
19	15-953	RH Control Panel	1
20	10-694	RH Panel Cover	1
21	10-824	RH Fender Bracket	1
22	30-404	RH Front Fender	1
23	15-781	Drink Cup Holder	1
24	20-659	Mud Flap	2
25	15-940	RH Fender Brace	1
	15-939	LH Fender Brace (not shown)	1
	HBCL-516-18-100	Carriage Bolt, 5/16 - 18 x 1	8
	HNFL-516-18	Flange-Loc Nut, 5/16 - 18	8
26	HB-14-20-075	Hex Bolt, 1/4 - 20 x 3/4	6
	HNFL-14-20	Flange-Loc Nut, 1/4 - 20	6
27	HWF-14-150	Fender Washer, 1/4 x 1 1/2	6
28	60-106	Park Brake Handle	1
29	15-935	Seat Belt Bracket	2
	HB-38-16-150	Hex Bolt, 3/8 - 16 x 1 1/2	4
	HNTL-38-16	Lock Nut, 3/8 - 16	4
30	10-697	Seat Prop Rod	1
	HW-38	Flat Washer, 3/8	2
	HP-18-075	Cotter Pin, 1/8 x 3/4	2
31	50-081	Rubber Bumper	2
	HNTL-38-16	Lock Nut, 3/8 - 16	2
32	20-730-01	Speedometer Speed Sensor	1
33	20-660	Mud Flap Strap	2



OIL TANK -OIL FILTER DRAWING

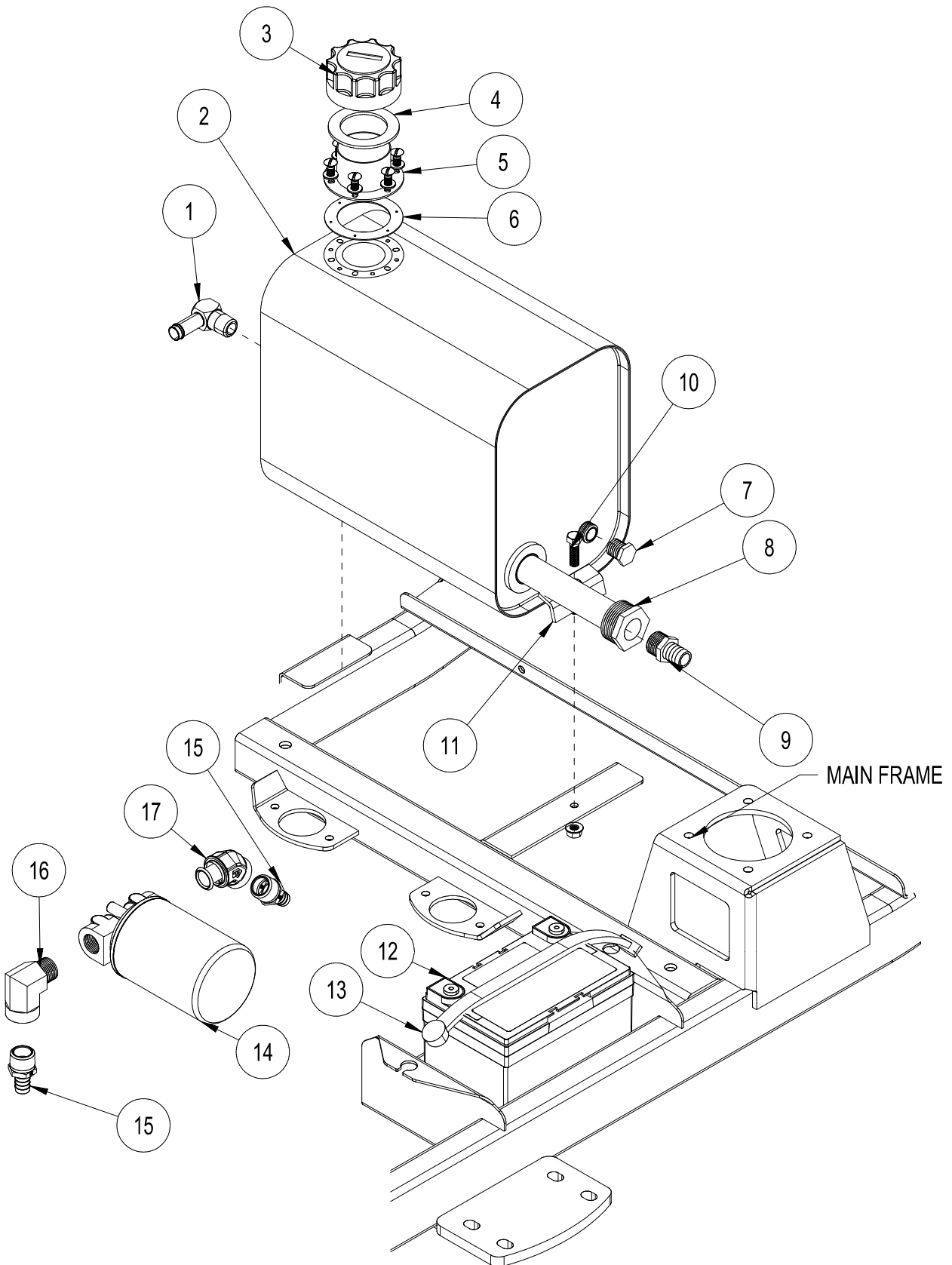

PARTS

OIL TANK -OIL FILTER PARTS LIST

REF#	PART#	DESCRIPTION	QUANTITY
1	23-142	Connector	1
2	60-473	Hydraulic Oil Tank	1
3	13-747	Filler Breather (includes * items)	1
4*	13-586-01	Cap Gasket	1
5	13-586-03	Neck	1
	HSM-10-32-063	Machine Screw, 10 - 32 x 5/8	6
	HWL-10	Lock Washer, #10	6
6*	13-586-02	Bottom Gasket	1
7	18-069	Replacement Plug	1
8	60-213	Strainer	1
9	18-249	Barb Fitting	1
10	HB-516-18-150	Hex Bolt, 5/16 -18 x 1 1/2	1
	HW-516	Flat Washer, 5/16	1
	HNTL-516-18	Lock Nut. 5/16 -18	1
11	75-792	Tank Hold-down	1
12	33-216	Battery	1
13	8-603	Battery Strap	1
14	26-016	Oil Filter Assembly	1
	23-031	Replacement Filter Element, 25 Micron	1
15	18-520	Hose Barb Fitting	2
16	18-140	90° Street Elbow, 3/4"	1
17	18-106	45° Street Elbow, 3/4"	1
NS	75-518	Red Battery Cable	1
	45-416	Battery Boot	1
	76-327	Ground Battery Cable	1

CARB CANISTER-FUEL TANK DRAWING

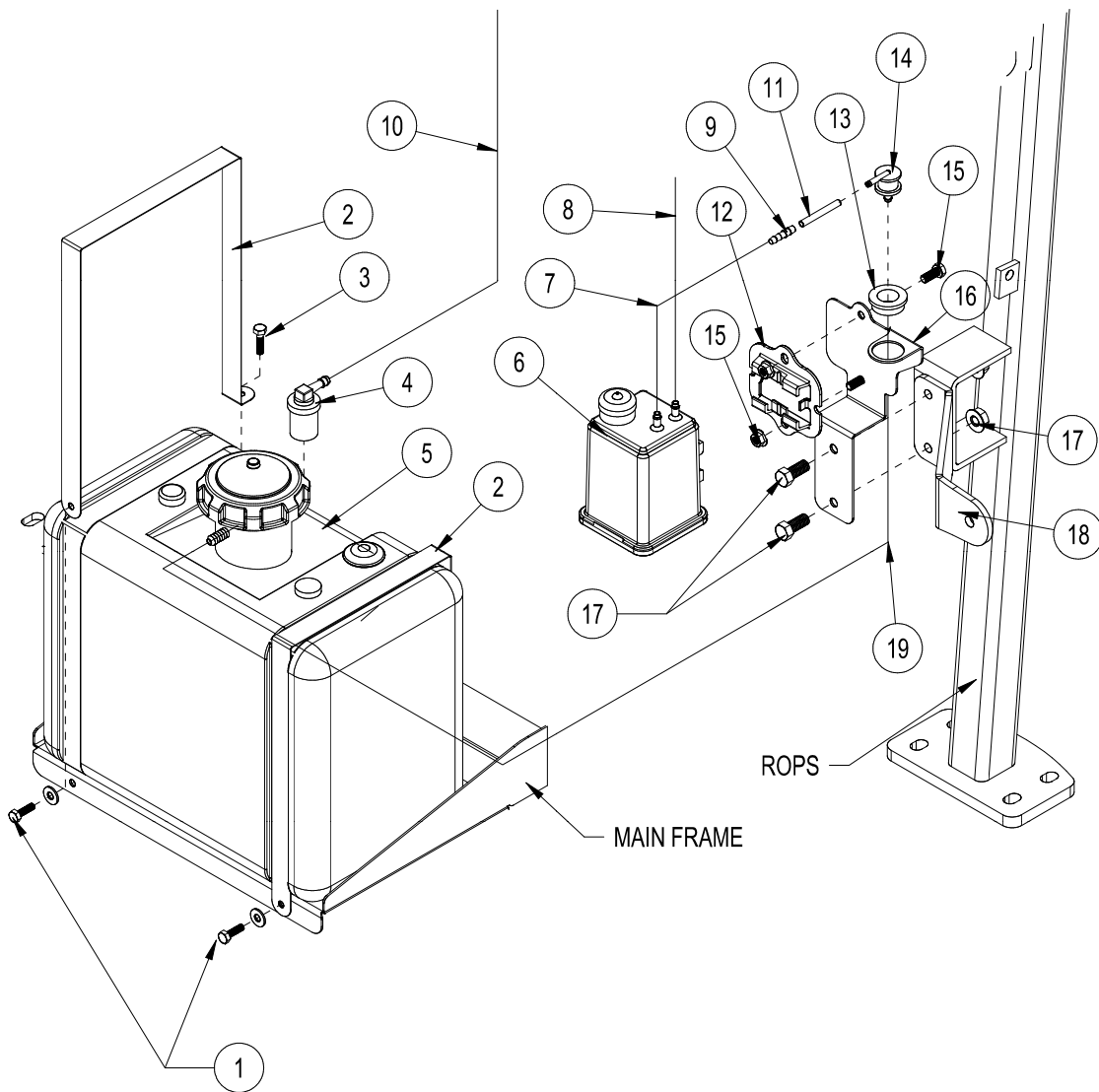

PARTS

CARB CANISTER-FUEL TANK PARTS LIST

REF#	PART#	DESCRIPTION	QUANTITY
1	HB-14-20-075	Hex Bolt, 1/4 -20x 3/4	2
	HW-14	Flat Washer, 1/4	2
	HNTL-14-20	Lock Nut, 1/4 - 20	2
2	78-456	Tank Strap	2
3	HB-14-20-100	Hex Bolt, 1/4 - 20 x 1	2
	HNTL-14-20	Lock Nut, 1/4 - 20	2
4	42-814-05	Rollover Valve (comes with tank)	1
5	15-838	Gas Tank	1
	15-838-01	Dial Fuel Level Gauge (replacement)	1
	42-814-02	Vented Cap with Gauge (replacement)	1
6	8-738	CARB Canister	1
7	8800	1/4" Fuel Hose	12"
8	9025	3/16" Fuel Hose (canister to engine)	20"
9	42-816	Thermobarb Reducer	1
10	8800	1/4" Fuel Hose (tank to engine)	60"
	18-186	Hose Clamp	1
11	9025	3/16" Fuel Hose	2"
12	8-688	Canister Mount	1
13	10-831	Rubber Grommet	1
14	8-684	Rollover Valve	1
	18-186	Hose Clamp	2
15	HB-516-18-075	Hex Bolt, 5/16-18-075	2
	HNFL-516-18	Flange Whiz-loc Nut, 5/16-18	2
16	10-829	Canister Mount Bracket	1
17	HB-38-16-150	Hex Bolt, 3/8 - 16 x 1 1/2	2
	HNTL-38-16	Lock Nut, 3/8-16	2
18	15-935	Seat Belt Bracket	1
19	8800	1/4" Fuel Hose	84"
	18-186	Hose Clamp	1
NS	50-403	Replacement Inline Fuel Filter	1

HYDROSTATIC PUMP DRAWING

PARTS

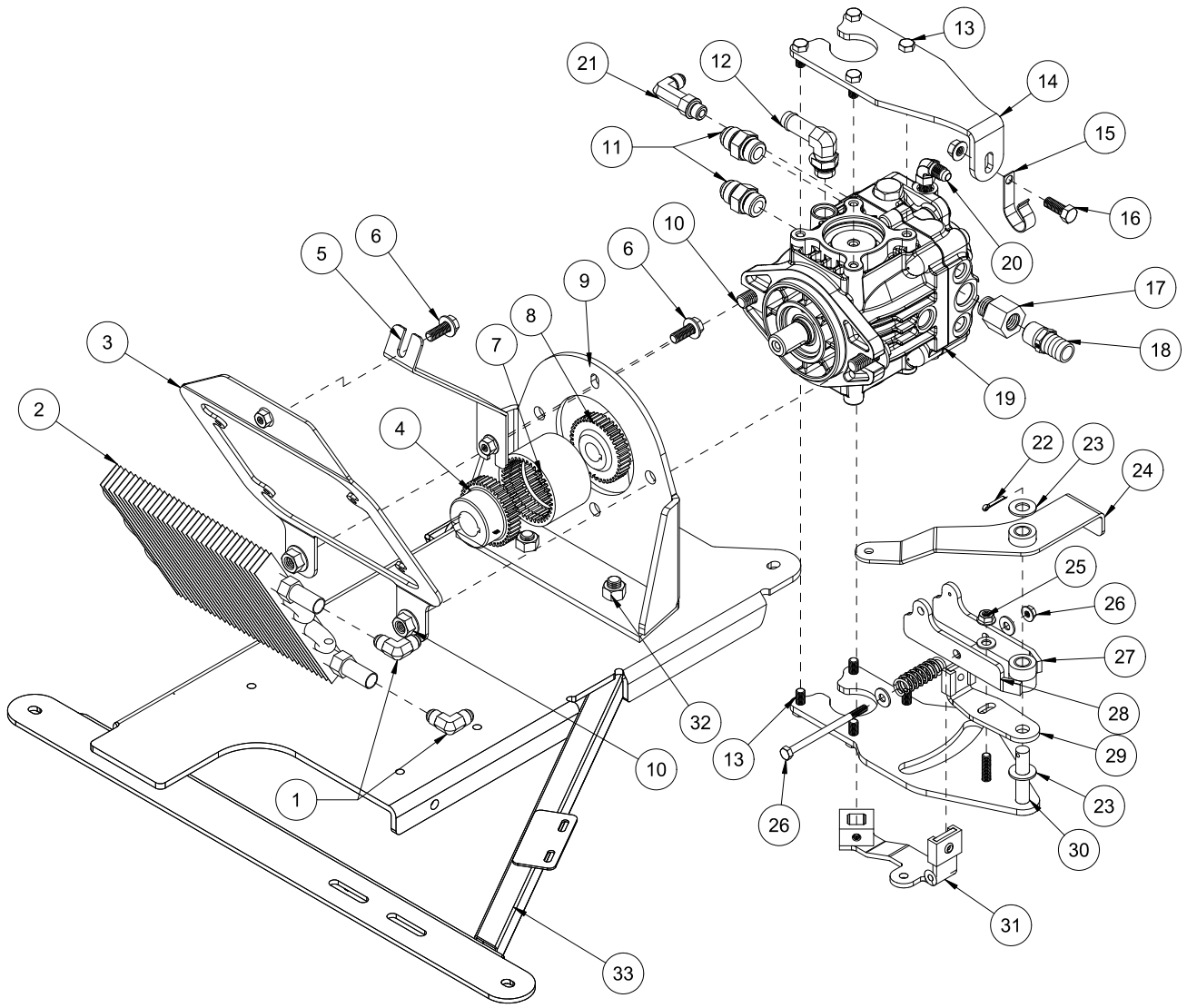

HYDROSTATIC PUMP PARTS LIST

REF#	PART#	DESCRIPTION	QUANTITY
1	18-519	90° Tube Fitting	2
2	45-382	Oil Cooler w/ mount kit	1
3	10-805	Oil Cooler Mount	1
4	48-269	7/8" Coupler Half	1
5	10-806	Oil Cooler Brace	1
6	HB-38-16-100	Hex Bolt, 3/8 - 16 x 1	2
	HW-38	Flat Washer, 3/8	2
	HNFL-38-16	Flange Whiz-loc Nut, 3/8-16	2
7	43-098	Insert	1
8	43-099	1" Bore Splined Half	1
9	10-803	Pump Mount	1
10	HB-12-13-175	Hex Bolt, 1/2 - 13 x 1 3/4	2
	HW-12	Flat Washer, 1/2	2
	HNTL-12-13	Lock Nut, 1/2 - 13	2
11	18-505	Adapter	2
12	18-364	90° Hose Barb	1
13	HBM-8-1.25-20	Metric hex Bolt, M8-1.25-20	8
	HWL-8	Lock Washer, #8	8
14	10-804	Hose Brace	1
15	HLC-A-58	Loom Clamp, 5/8	1
16	HB-516-18-075	Hex Bolt, 5/16 - 18 x 3/4	1
	HNFL-516-18	Flange Whiz-loc Nut, 5/16-18	1
17	18-240	Female Pipe Adapter	1
18	18-133	Hose Barb, 1/2 x 3/4	1
19	45-373	DDC Piston Pump	1
20	18-168	Elbow, 3/8 Straight Thread	1
21	18-506	Elbow	1
22	HP-18-075	Cotter Pin, 1/8 x 3/4	1
23	HMB-12-14	Machine Bushing, 1/2 x 14GA	2
24	10-801	Spray Boss Arm	1
25	HNTL-516-18	Lock Nut, 5/16 - 18	1
	HW-516	Washer, 5/16	1
26	HB-14-20-400	Hex Bolt, 1/4 - 20 x 4	1
	HW-14	Flat Washer, 1/4	2
	10-477	Compression Spring	1
	HNTL-14-20	Lock Nut, 1/4 - 20	1
27	45-368	Top Centering Arm	1
28	45-367	Bottom Centering Arm	1
29	45-327	Wheel Creep Arm	1
30	10-798	Control Mount	1
	HSSHS-14-20-025	Set Screw, 1/4 - 20 x 1/4	1
31	10-799	Swash Arm	1
32	HB-12-13-125	Hex Bolt, 1/2 - 13 x 1 1/4	2
	HNTL-12-13	Lock Nut, 1/2-13	2
33	10-796	Engine Mount	1

ENGINE AND SPRAY PUMP DRAWING

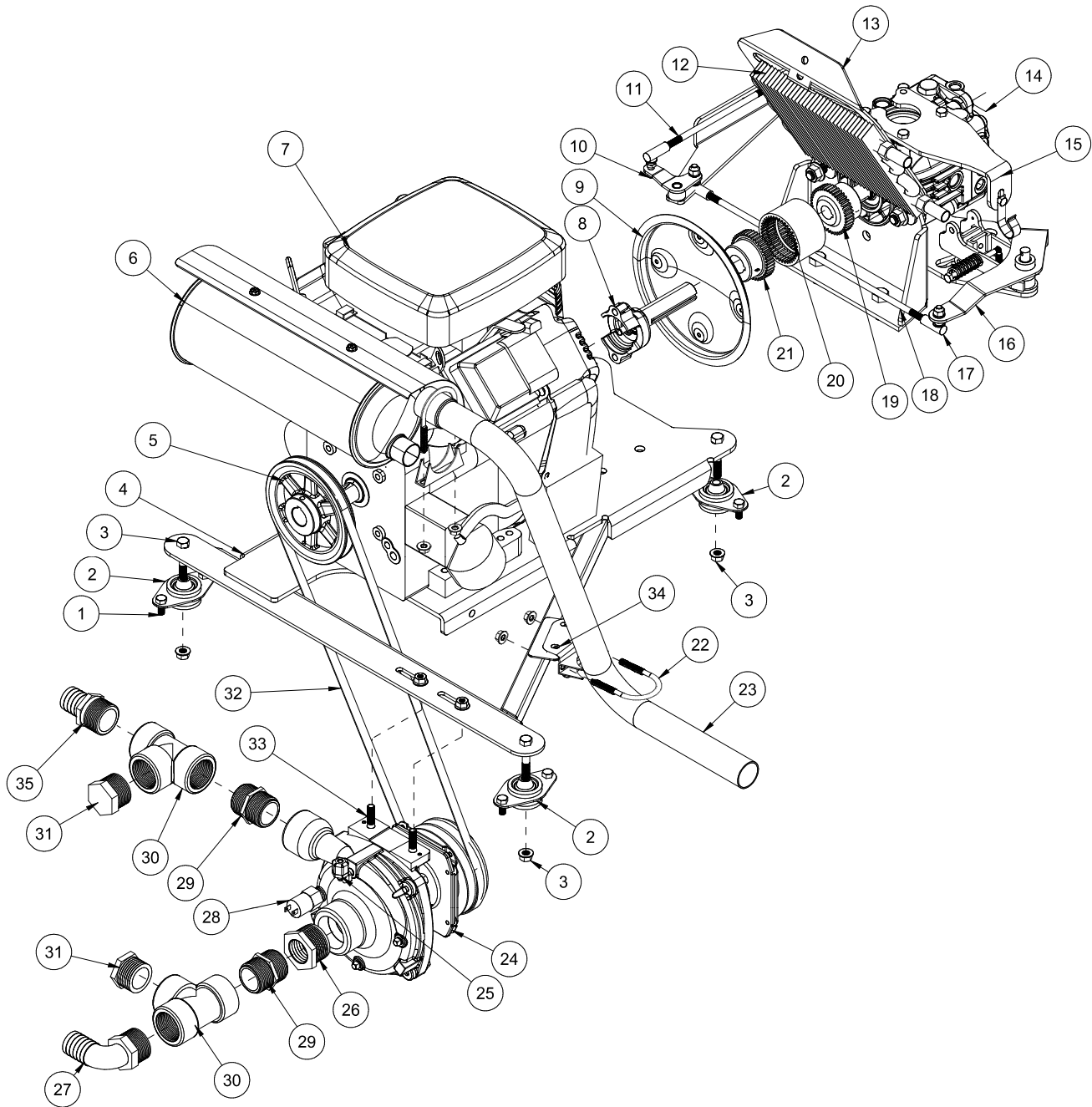

ENGINE AND SPRAY PUMP PARTS LIST

REF#	PART#	DESCRIPTION	QUANTITY
1	HB-516-18-075	Hex Bolt, $\frac{5}{16}$ - 18 x $\frac{3}{4}$	8
	HNFL-516-18	Flange Whiz-loc Nut, $\frac{5}{16}$ -18	8
2	20-618	Rubber Isolators	4
3	HB-38-16-275	Hex Bolt, $\frac{3}{8}$ - 16 x $2\frac{3}{4}$	4
	HW-38	Flat Washer, $\frac{3}{8}$	4
	HNFL-38-16	Flange Whiz-loc Nut, $\frac{3}{8}$ - 16	4
4	10-796	Engine Mount	1
5	10-787	Pulley	1
	HKSQ-14-100	Square Key, $\frac{1}{4}$ x 1	1
6	10-786	Muffler	1
7	10-753	Briggs, 23HP Engine	1
	10-575-02	Air Filter	1
	10-575-03	Air Filter Pre-Cleaner	1
	13-531	Engine Oil Filter	1
	13-491	Oil Sender	1
	17-619	Ignition plug	1
8	10-754	Stub Shaft	1
9	10-755	Screen	1
10	10-802	Spray Boss Relay	1
11	43-220	Speed Boss Link	1
	HN-516-24	Hex Nut, $\frac{5}{16}$ -24	2
12	45-382	Oil Cooler w/ mount kit	1
13	10-805	Oil Cooler Mount	1
14	45-373	DDC Piston Pump	1
15	10-804	Hose Brace	1
16	10-801	Spray Boss Arm	1
17	21-462	Ball Joint, $\frac{5}{16}$ - 24	3
	HN-516-24	Hex Nut, $\frac{5}{16}$ -24	3
18	42-155	Brake Rod	1
	HN-516-24	Hex Nut, $\frac{5}{16}$ -24	2
19	43-099	1" Bore Splined Half	1
20	43-098	Insert	1
21	48-269	$\frac{7}{8}$ " Coupler Half	1
22	50-111	Muffler Clamp, 1 $\frac{1}{2}$ "	2
23	10-785	Exhaust Tailpipe	1
24	15-984	Hypro Spray Pump	1
25	18-475	Male Elbow	1
26	16-973	Reducer, 1 $\frac{1}{2}$ x 1 $\frac{1}{4}$	1
27	16-156	Elbow, 1 $\frac{1}{4}$ MPT x 1 $\frac{1}{4}$ HB	1
28	33-480	Pressure Switch	1
29	16-880	Close Nipple, 1 $\frac{1}{4}$	2
30	18-390	Pipe Tee, 1 $\frac{1}{4}$	2
31	10-389	Plug, 1 $\frac{1}{4}$	2
32	10-828	V-Belt	1
33	HBM-10-1.5-35	Metric Bolt, M0 -1.5 x 35	2
	HW-38	Flat Washer, $\frac{3}{8}$	2
	HWLM-10	Metric Lock Washer, M10	2
	HNM-10-1.5	Metric Nut, M10-1.5	2
34	10-810	Tailpipe Brace	1
	HB-516-18-07	Hex Bolt, $\frac{5}{16}$ - 18 x $\frac{3}{4}$	2
	HNFL-516-18	Flange Whiz-loc Nut, $\frac{5}{16}$ -18	2
35	16-161	Fitting, 1 $\frac{1}{4}$ MPT x 1 $\frac{1}{4}$ HB	1



PARK BRAKE AND REAR AXLE DRAWING

PARTS

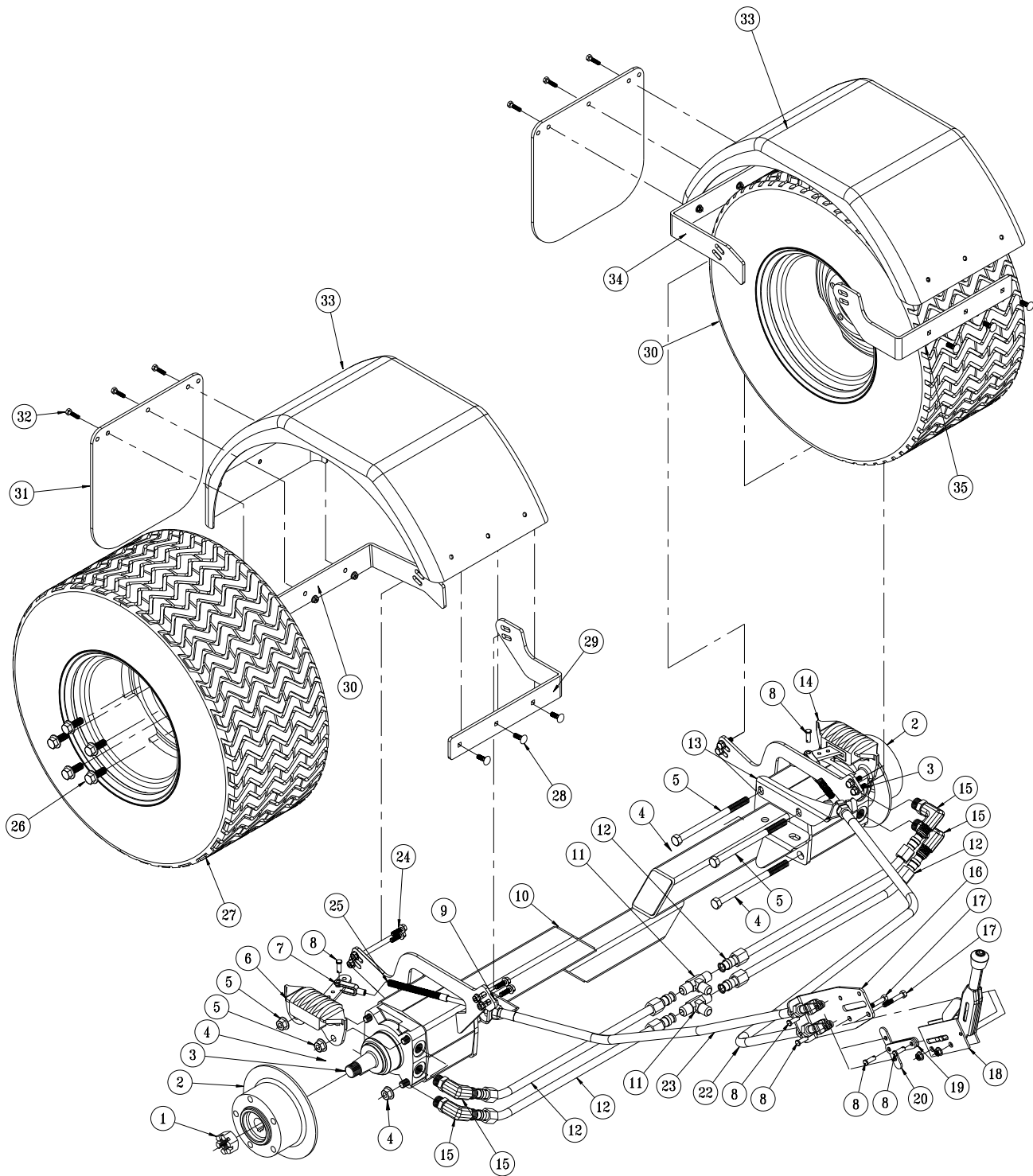

PARK BRAKE AND REAR AXLE PARTS LIST

REF#	PART#	DESCRIPTION	QUANTITY
1	14-265	Lug Nut (comes with wheel motor)	2
2	76-239	Brake Disc, 5-hole	2
3	10-510	Wheel Motor	2
	HMB-100-14	Machine Bushing, 1 x 14GA	1
	HWK-516-100	Woodruff Key, $\frac{5}{16}$ x 1 (comes with wheel motor)	2
4	HB-12-13-750	Hex Bolt, $\frac{1}{2}$ - 13 x $7\frac{1}{2}$	4
	HNFL-12-13	Flange Whiz-loc Nut, $\frac{1}{2}$ -13	4
5	HB-12-13-800	Hex Bolt, $\frac{1}{2}$ - 13 x 8	4
	HNFL-12-13	Flange Whiz-loc Nut, $\frac{1}{2}$ - 13	8
6	76-241	Right Caliper CW	1
	34-101-02	Pad Kit	1
7	11-100	Linkage Yoke, $\frac{5}{16}$ "	2
	HN-516-24	Hex Nut, $\frac{5}{16}$ - 24	2
8	HCP-516-100	Clevis Pin, $\frac{5}{16}$ x 1	6
	HP-18-075	Cotter Pin, $\frac{1}{8}$ x $\frac{3}{4}$	6
9	10-589	RH Brake Cable Bracket	1
10	20-891	Rear Axle	1
11	34-057	Tee	2
12	20-656	Hydraulic Tube	4
13	10-588	LH Brake Cable Bracket	1
14	76-240	Left Caliper CCW	1
	34-101-02	Pad Kit	1
15	34-122	Short Elbow	4
16	15-942	Cable Bracket	1
17	HB-516-18-200	Hex Bolt, $\frac{5}{16}$ -18 x 2	2
	HNTL-516-18	Lock Nut, $\frac{5}{16}$ - 18	2
18	60-106	Park Brake Lever Kit	1
19	45-074	Park Brake Link	2
20	10-591	Brake Equalizer	1
22	10-784	LH Brake Cable	1
23	10-783	RH Brake Cable	1
24	HB-516-18-075	Hex Bolt, $\frac{5}{16}$ - 18 x 1	8
	HW-516-18	Washer, $\frac{5}{16}$ - 18	8
	HNFL-516 - 18	Flange Whiz-loc Nut, $\frac{5}{16}$ - 18	8
25	15-949	Compression Spring	2
	HW-14	Flat Washer, $\frac{1}{4}$	2
26	60-268	Lug Bolt, $\frac{1}{2}$ -20 x $1\frac{5}{16}$	10
27	16-225	Rear Tire and Wheel	2
	16-225-01	Tire, 24 x 13.00 - 12NHS 4 Ply	2
	16-225-02	Wheel	2
28	HBCL-516-18-100	Carriage Bolt, $\frac{5}{16}$ - 18 x 1	6
	HW-516	Flat Washer, $\frac{5}{16}$	6
	HNFL-516-18	Flange Whiz-loc Nut, $\frac{5}{16}$ -18	6
29	20-964	Front Right Fender Bracket	1
30	20-966	Rear Right Fender Bracket	1
31	20-659	Mud Flap	2
32	HSTP-516-18-100	Truss Head Screw, $\frac{5}{16}$ - 18 x 1	6
	HW-516	Flat Washer, $\frac{5}{16}$	6
	HNFL-516-18	Flange Whiz-loc Nut, $\frac{5}{16}$ -18	6
33	20-958	Rear Fender- Orange	2
34	20-967	Rear Left Fender Bracket	1
35	20-965	Front Left Fender Bracket	1

SPRAY TANK PARTS LIST

REF#	PART#	DESCRIPTION	QUANTITY
1	10-759	Air Gap Filler	1
2	16-961	Aluminum Adapter 1" Female Thread	1
3	16-162	1" Hex Plug	2
4	16-945	Double Head Fitting	3
5	10-410	Rear Tank Strap	1
6	HB-38-16-275	Hex Bolt, $\frac{3}{8}$ - 16 x $2\frac{3}{4}$	4
	HNTL-38-16	Lock Nut, $\frac{3}{8}$ - 16	4
7	10-111	110 Gallon Poly Tank	1
8*	16-194	Anti-Vortex Fitting $1\frac{1}{4}$	1
9	10-112	Tank Carrier	1
10	16-156	Elbow $1\frac{1}{4}$ MPT x $1\frac{1}{4}$ HB	3
11	16-155	Elbow, $\frac{3}{4}$ MPT x 1 HB	1
12*	16-150	Double Threaded Fitting, $\frac{3}{4}$	2
13	15-984	Hypro® Pump	1
14	18-475	Male Elbow	2
15	9038	$\frac{1}{4}$ " Tubing	30"
16	10-390	Reducer	1
17	22-528	Front Tank Strap	1
18*†	14-532	16" Hinged Lid/Well with Gasket	1
19	10-639	Lid Stop	1
	HRS-316-100	Rivet, $\frac{3}{16}$ x 1	2
	HRW-316	Pop Rivet Washer, $\frac{3}{16}$	2
20	18-448	1" Ball Valve	1
21	16-962	Aluminum Coupler 1" Male Thread	1
22	8897	$1\frac{1}{4}$ Discharge Hose	18"
	18-222	Hose Clamp	2
23	16-935	Quick Coupler Cap	1
24	16-180	Male Quick Coupler	1
25	18-372	3-Way valve	1
	18-372-01	T-handle	1
26	16-161	$1\frac{1}{4}$ " HBxMPT	2
27	8897	$1\frac{1}{4}$ Discharge Hose	21"
	18-222	Hose Clamp	2
28	10-389	Plug, $1\frac{1}{4}$	2
29	18-390	Pipe Tee, $1\frac{1}{4}$	2
30	16-880	Close Nipple, $1\frac{1}{4}$	2
31	33-480	Pressure Switch	1
32	16-973	Reducer, $1\frac{1}{2}$ x $1\frac{1}{4}$	1
33	16-971	45° Elbow (inside tank)	1
34	16-169	Strainer Basket 16"	1

* Comes with 110 Gallon Poly Tank (only one 16-150 Double Threaded Fitting in bottom of tank)

† Lid Replacement Parts

16-953-01	Lid Gasket (between lid and mounting ring)	1
20-663	Tank Gasket (between tank and mounting ring)	1
HRS-316-1125	Steel Rivet, $\frac{3}{16}$ x $1\frac{1}{8}$	8
HRW-3/16	Rivet Pop Washer, $\frac{3}{16}$	8

TURBO-QUAD AGITATOR DRAWING

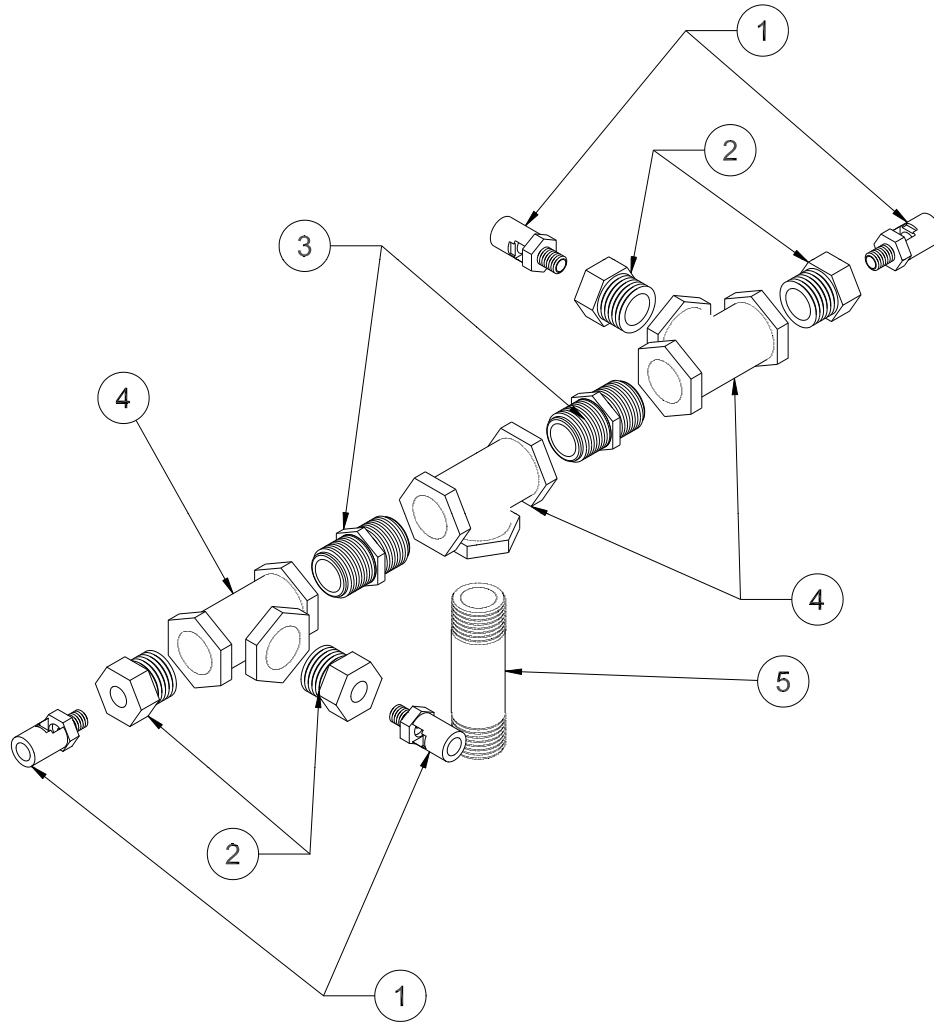

PARTS

REF#	PART#	DESCRIPTION	QUANTITY
1	18-510	Mini Eductor	4
2	16-288	Reducer, $\frac{3}{4} \times \frac{1}{4}$	4
3	16-158	Close Nipple, $\frac{3}{4} \times \frac{3}{4}$	2
4	16-157	Female Pipe Thread Tee, $\frac{3}{4} \times \frac{3}{4} \times \frac{3}{4}$	3
5	16-172	Nylon Nipple, $\frac{3}{4}$ NPT x $3\frac{1}{2}$	1

10-510 WHEEL MOTOR DRAWING

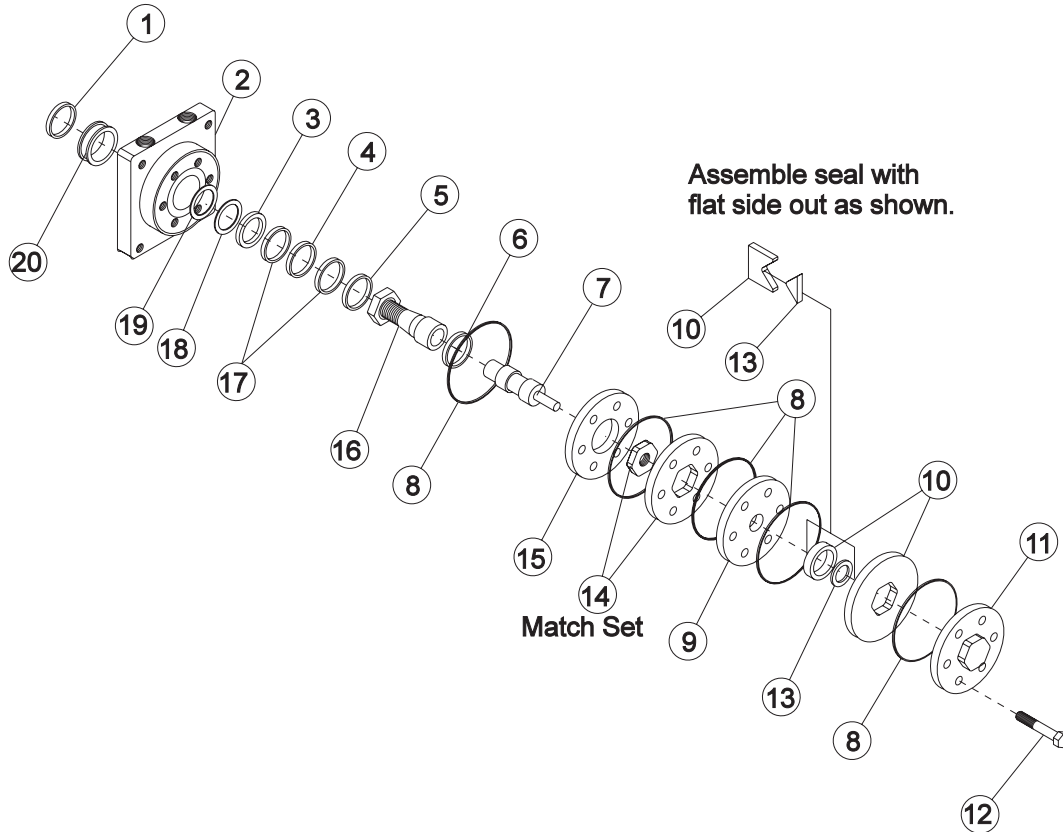

REF#	PART#	DESCRIPTION	QUANTITY
1*	13-032-39	Water & Dirt Seal	1
2	13-615-05	Service Housing Assembly (Includes Ref 4, 5, 17(2 req'd) and 20)	1
3*		Inner Seal	1
4	13-032-27	Thrust Bearing	1
5	13-032-28	Inner Bearing	1
6	13-032-29	Thrust Bearing	1
7	10-510-01	Drive Link	1
8*		Ring Seal	5
9	13-032-31	Manifold	1
10	13-032-32	Commutator Assembly (matched set)	1
11	13-032-33	End Cover	1
12	10-510-02	Special Bolt	7
13*		Commutator Seal (matches with #10)	1
14	10-510-03	Rotor Set (matched set)	1
15	10-510-04	Wear Plate	1
16	13-615-04	Coupling Shaft	1
	HWK-516-100	Woodruff Key $\frac{5}{16} \times 1$	1
	14-265	Nut 1 - 20	1
17	13-032-37	Thrust Washer	2
18*		Backup Washer	1
19*		Backup Ring	1
20	13-032-38	Outer Bearing	1
*	14-080	Seal Kit	1

15-301 ORBITAL DRAWING

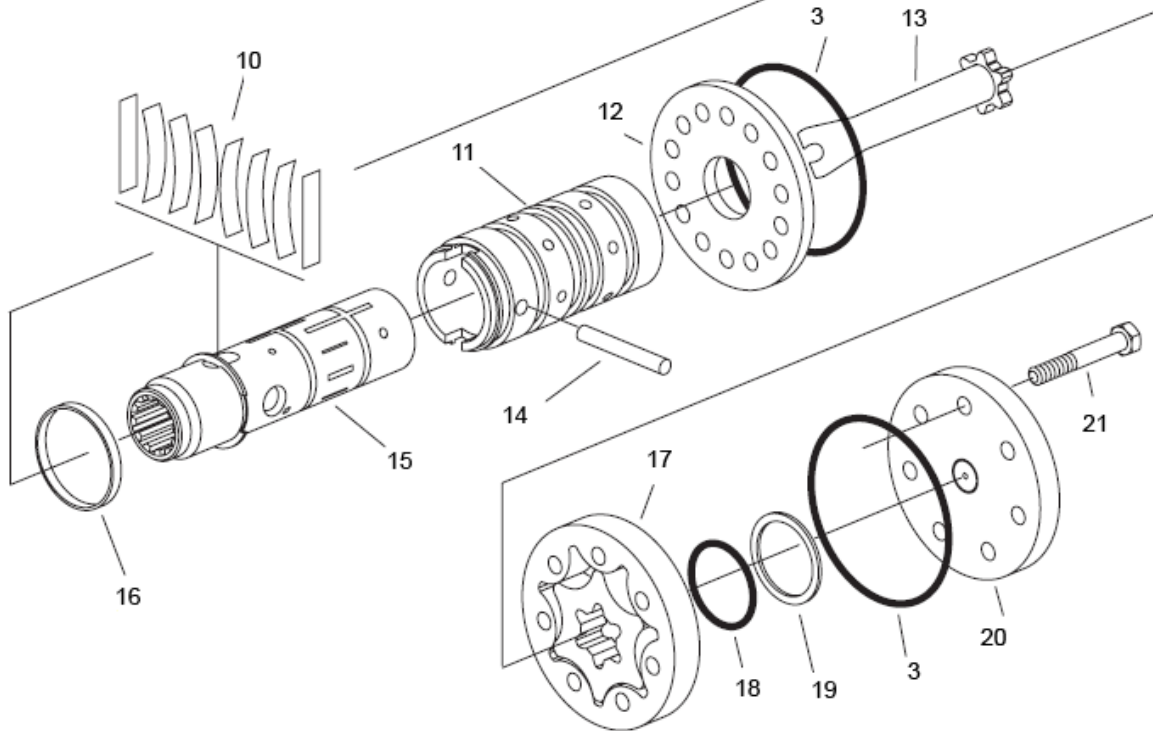
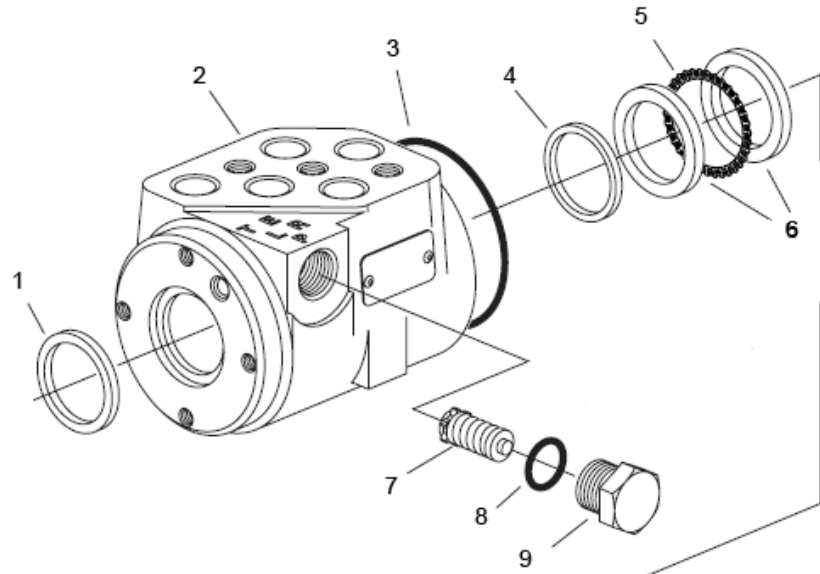

PARTS

15-301 ORBITAL PARTS LIST

REF #	PART #	DESCRIPTION	QUANTITY
1**		Dust Seal	1
2		Housing	1
3**		O-Ring Seal	3
4**		Quad Seal	1
5	10-576-03	Thrust Bearing	1
6	10-576-02	Bearing Race	2
7		Manual Steering Relief Valve	1
8**		O-ring	1
9		Plug	1
10‡		Standard Torque Centering Springs	1
11		Sleeve	1
12	15-301-06	Wear Plate	1
13	10-576-01	Drive	1
14	15-301-08	Drive Pin	1
15		Spool	1
16‡		Spring Retaining Ring	1
17	10-576-05	Gerotor	1
18**		O-Ring	1
19**		Seal Ring	1
20	15-301-03	End Cap	1
21	10-576-06	Cap Screw	7
**	15-301-01	Seal Kit	1
‡	15-301-15	Centering Spring Kit	1

15-301 ORBITAL SPECIFICATIONS

Inlet Relief Valve Setting 1020 psi (70 bar)
 Nominal Flow 3 gpm (11 lpm)
 Displacement 4.50 cu. in/ R (73.8 cu cm/R)
 Check Valve for Manual Steering Yes
 Inlet Pressure Rating 2030 psi (140 bar)
 Return Pressure Rating 145 psi (10 bar) Maximum
 Fluid SAE 10W-40 API Service SJ or higher Motor Oil
 Ports $\frac{9}{16}$ - 18 SAE O-Ring 4 Ports

45-373 DDC20 PISTON PUMP DRAWING

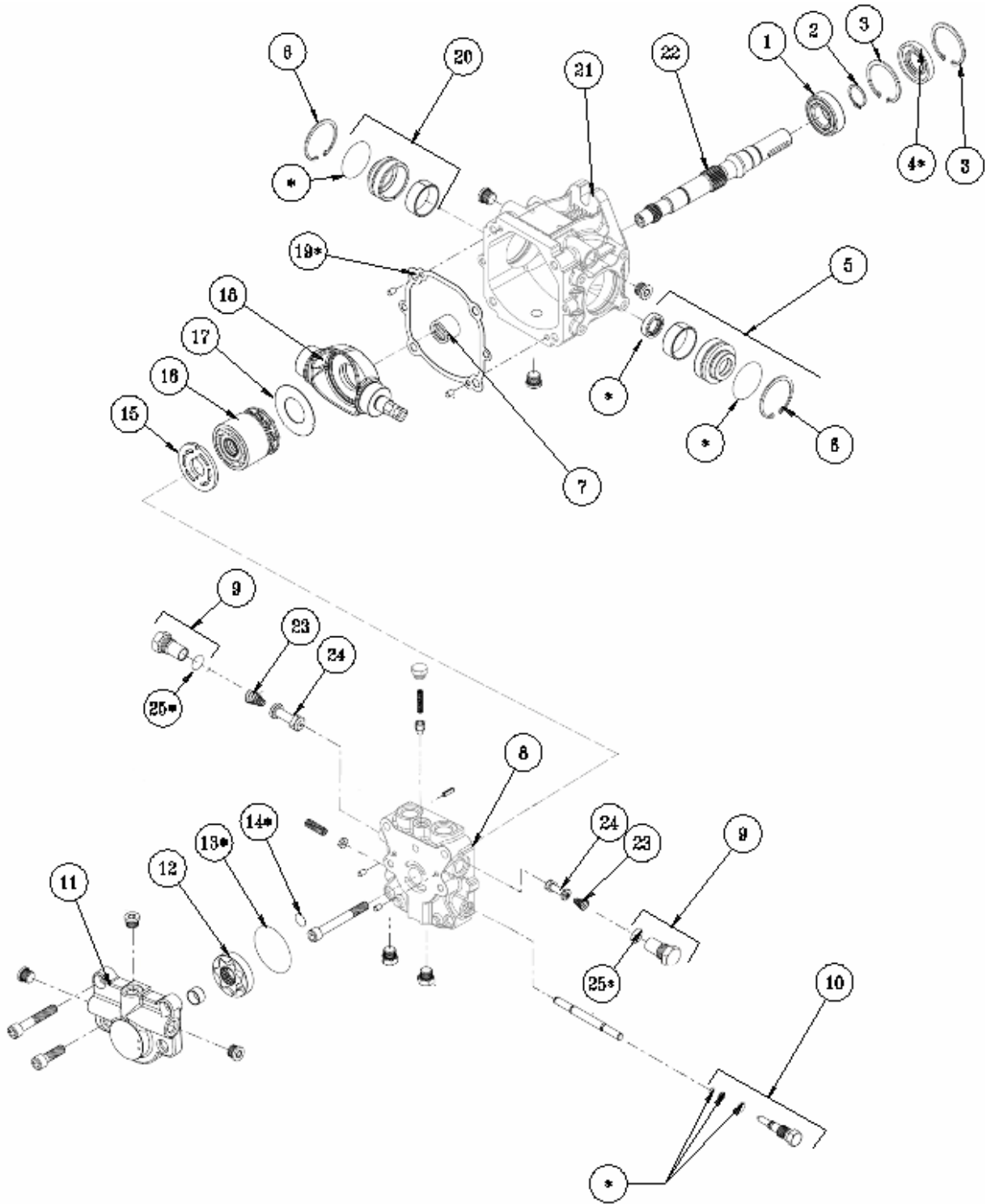

PARTS

45-373 DDC PISTON PUMP PARTS LIST

REF#	PART#	DESCRIPTION	QUANTITY
1	45-373-02	Ball Bearing	1
2	45-373-03	Retaining Ring	1
3	45-373-04	Retaining Ring	2
4*		Lip Seal	1
5	45-373-05	Journal Bearing Carrier Assembly	1
6	45-373-06	Retaining Ring	1
7	45-373-07	Needle Bearing	1
8	45-373-08	End Cap	1
9	45-373-09	Plug Assembly	2
10	45-373-10	By-Pass Valve Assembly	1
11	45-373-11	Charge Pump Housing	1
12	45-373-12	Gerotor Assembly	1
13*		O-ring	1
14*		O-ring	1
15	45-373-13	Valve Plate CCW	1
16	45-373-14	Cylinder Block kit	1
17	45-373-15	Thrust Plate	1
18	45-373-16	Swash Plate, Axial Offset	1
19*		Gasket	1
20	45-373-17	Journal Bearing Carrier Assembly	1
21	45-373-19	Housing	1
22	45-373-18	Pump Shaft	1
23	45-373-20	Compression Spring	2
24	45-373-21	Poppet, Check Valve	2
25*	45-373-22	Oring	2
*	45-373-01	Overhaul Kit	



15-984 HYPRO PUMP DRAWING

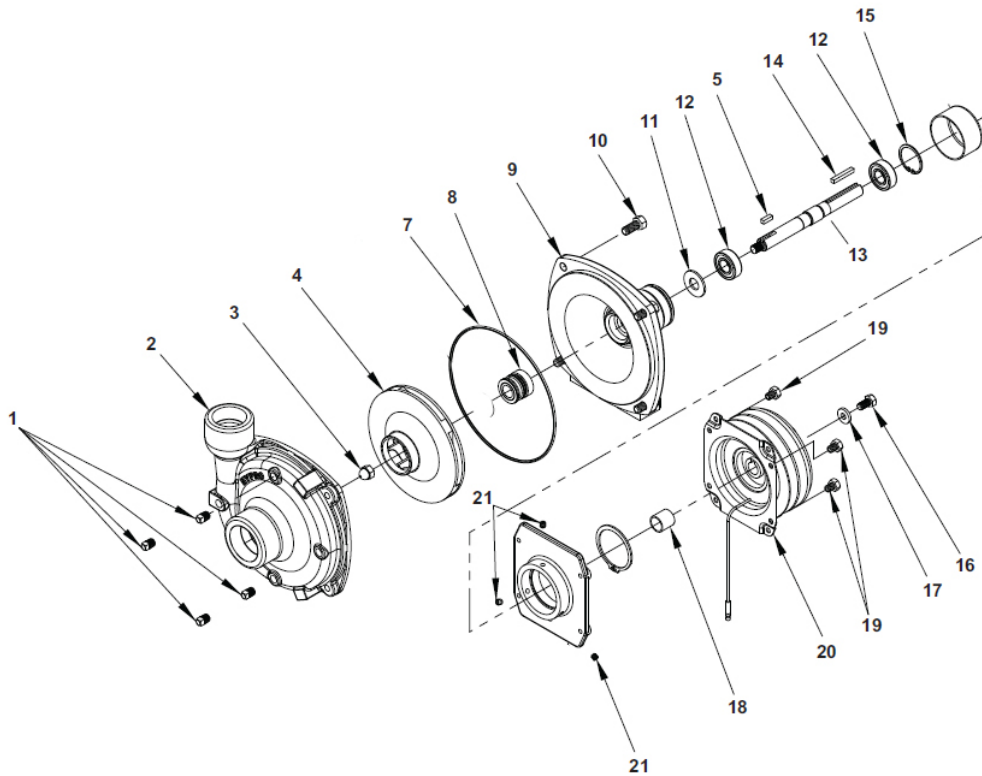

▲ IMPORTANT

When servicing the spray pump or filter, all control valves must be shut off if there is liquid in the tank.

REF#	PART#	DESCRIPTION	QUANTITY
1	16-998-01	Drain Plug	4
2	16-998-02	Pump Casing	1
3	16-998-03	Impeller Nut	1
4	16-966-16	Impeller	1
5	16-966-11	Key	1
7*	16-998-04	O-Ring	1
8*	16-967	Mechanical Seal (Silicon Carbide)	1
9	16-998-06	Mounting Flange	1
10	16-998-07	Bolt	
11	16-966-06	Slinger Ring	1
12	16-966-10	Ball Bearing	2
13	16-966-12	Pump Shaft	1
14†	16-822-20	Key	1
15	16-966-13	Bearing Retainer	1
16†		Bolt	1
17†		Retaining Washer	1
18†		Spacer	1
19		Bolt	4
20†	16-994-01	Clutch	1
21†		Set Screw	3
	16-998-12	Pump Only	
*	16-967	Silicone - Carbon Seal Kit	
†	16-998-13	Clutch Service Kit	

20-684-P FLOW METER

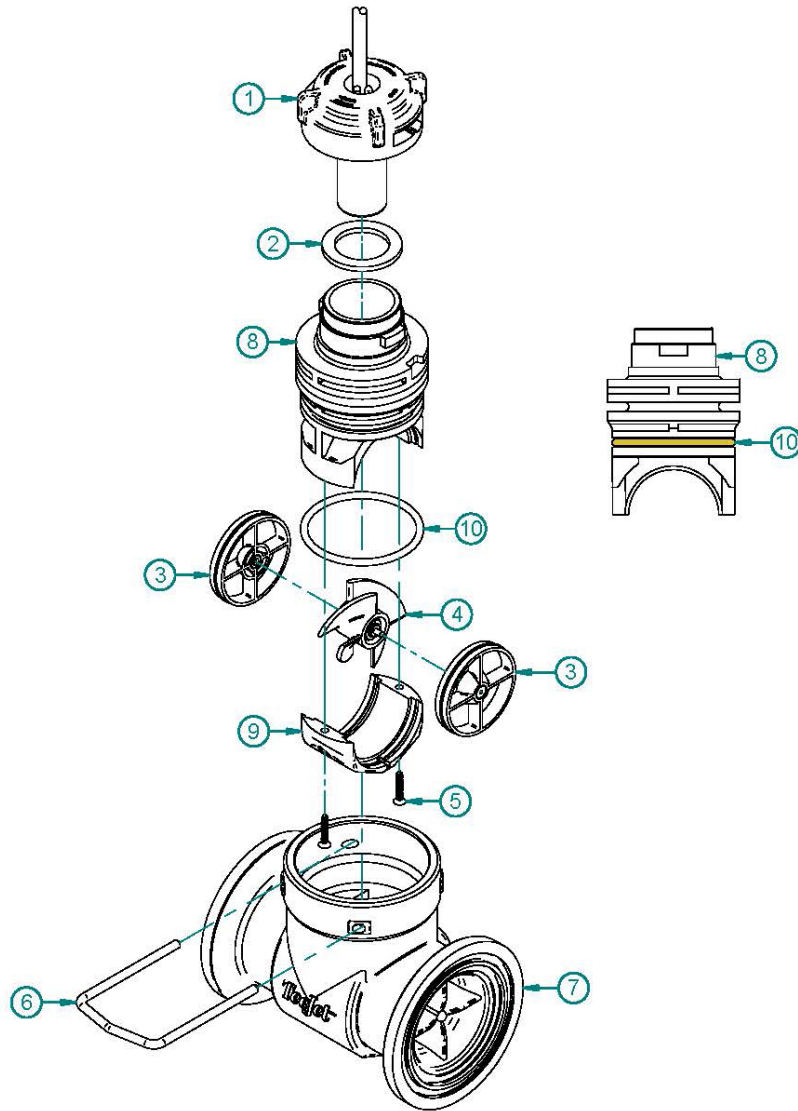

Parts

REF#	PART#	DESCRIPTION	QUANTITY
1	20-684-01	Sensor, PCB Assembly	1
2		Washer, Seal	1
3*		Guide Vane Bearing	2
4*		Turbine Assembly	1
5*		Flat Head Screw, #6 - 5/8	2
6		Pin, Retaining	1
7	20-684-04	Body	1
8*		Insert, Body	1
9*		End cap	1
10*	20-684-02	O-ring	1
*	20-684-03	802 Flow meter Repair Kit (includes all * items)	

1101 PLUMBING DRAWING (3-WAY MANUAL)

15-817 O-ring for 50 Series Clamp

15-818 O-ring for 75 Series Clamp

BOOM	LEFT HOSE	CENTER HOSE	RIGHT HOSE
15' OR 18'	9032-89	9032-65	9032-113

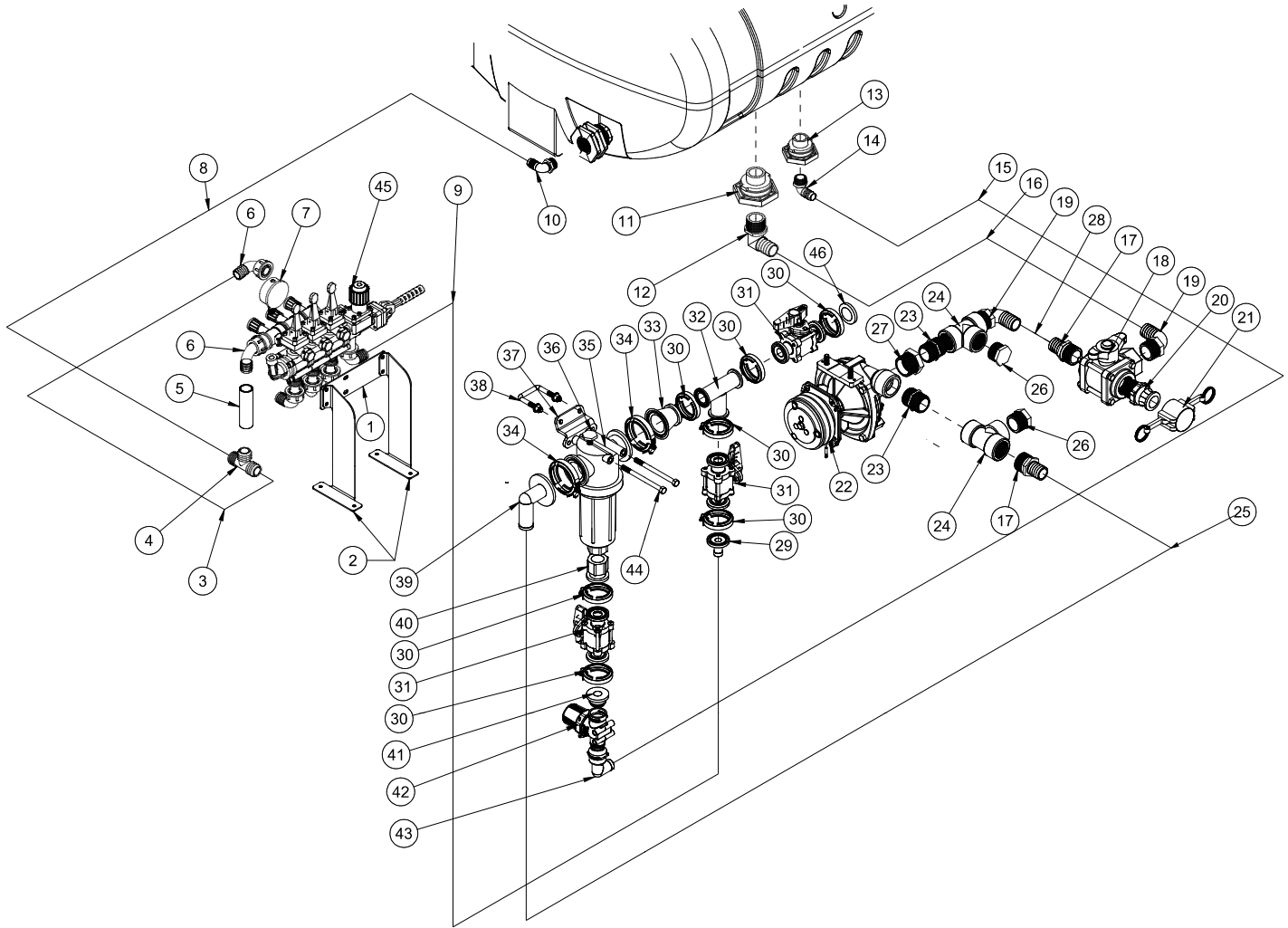

REF#	PART#	DESCRIPTION	QUANTITY
1	10-647	Mount Plate	1
2	10-646	Ball Valve Mount Bracket	2
3	8896	1" Discharge Hose	12"
	18-222	Hose Clamp	2
4	10-269	Plastic Tee	1
5	8896	1" Discharge Hose	4"
	18-222	Hose Clamp	2
6	10-268-13	90° Elbow (comes with 10-648)	3
	18-040	Hose Clamp	6
7	16-281	Liquid Filled Gauge	1
8	8896	Discharge Hose 1"	48"
	18-222	Hose Clamp	2
9	8896	Discharge Hose 1"	40"
	18-222	Hose Clamp	2
10	16-164	Elbow, 1 x 1HB	1

Accessories

1101 PLUMBING PARTS LIST (3-WAY MANUAL)

REF#	PART#	DESCRIPTION	QUANTITY
11	16-194	Anti-Vortex Fitting	1
12	16-156	Elbow	1
13		1/2" Double Thread Fitting (part of tank)	1
14	16-155	Elbow	1
15	8896	Discharge Hose 1"	53"
	18-222	Hose Clamp	2
16	8897	Discharge Hose 1 1/4"	18"
	18-116	Hose Clamp	2
17	16-161	Fitting 1 1/4 NPT x 1 1/4 HB	2
18	18-372	3-Way Ball Valve	1
	18-372-01	T-Handle	1
19	16-156	Elbow 1 1/4 MPT x 1 1/4 HB	2
20	16-180	Quick Coupler 1 1/4 Male	1
21	16-935	Quick Coupler 1 1/4 Cap	1
22	15-984	Hypro® Pump	1
23	16-880	Nipple	2
24	18-390	Pipe Tee 1 1/4	2
25	8897	Discharge Hose 1 1/4"	62"
	18-116	Hose Clamp, HS-24	2
26	10-389	Plug 1 1/4	2
27	16-825	Reducer	1
28	8897	Discharge Hose 1 1/4	21"
	18-116	Hose Clamp	2
29	15-808	Hose Barb Flange	1
30	15-740	50 Series Clamp	7
31	15-738	Flanged Ball Valve	3
32	15-776	50 Series Tee	1
33	15-748	Reducer Coupling	1
34	15-741	75 Series Clamp	2
35	15-737	Flanged Strainer	1
36	15-780	1/4" Poly Plug	1
37	30-551	Filter Mount	1
38	17-537	U-Bolt	1
39	15-739	75 Series 90° x 1 1/4 Hose Barb	1
40	15-735	50 Series 1 FPT	1
41	15-825	QC Flange Adapter	1
42	14-801	Agitation Strainer, 50 mesh	1
	14-802	50 Mesh Screen	
	14-803	Decal, Clean Strainer	1
43	14-671	Elbow, 90°	1
44	HB-38-16-500	Bolt, 3/8 - 16 x 5	2
	HNFL-38-16	Flange Lock Nut, 3/8 - 16	2
45	10-648	Valve 3-Way	1
46	15-778	50 Series Blank Cap	1

10-648 3-WAY MANUAL VALVE DRAWING

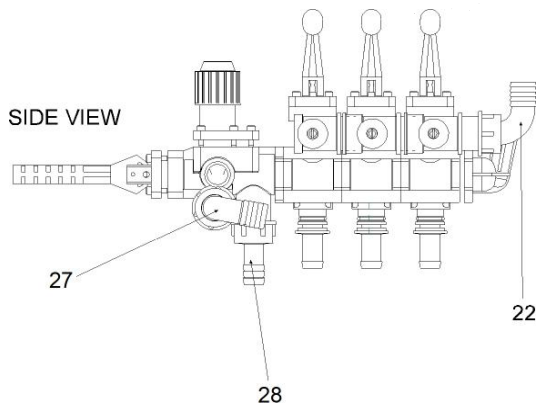
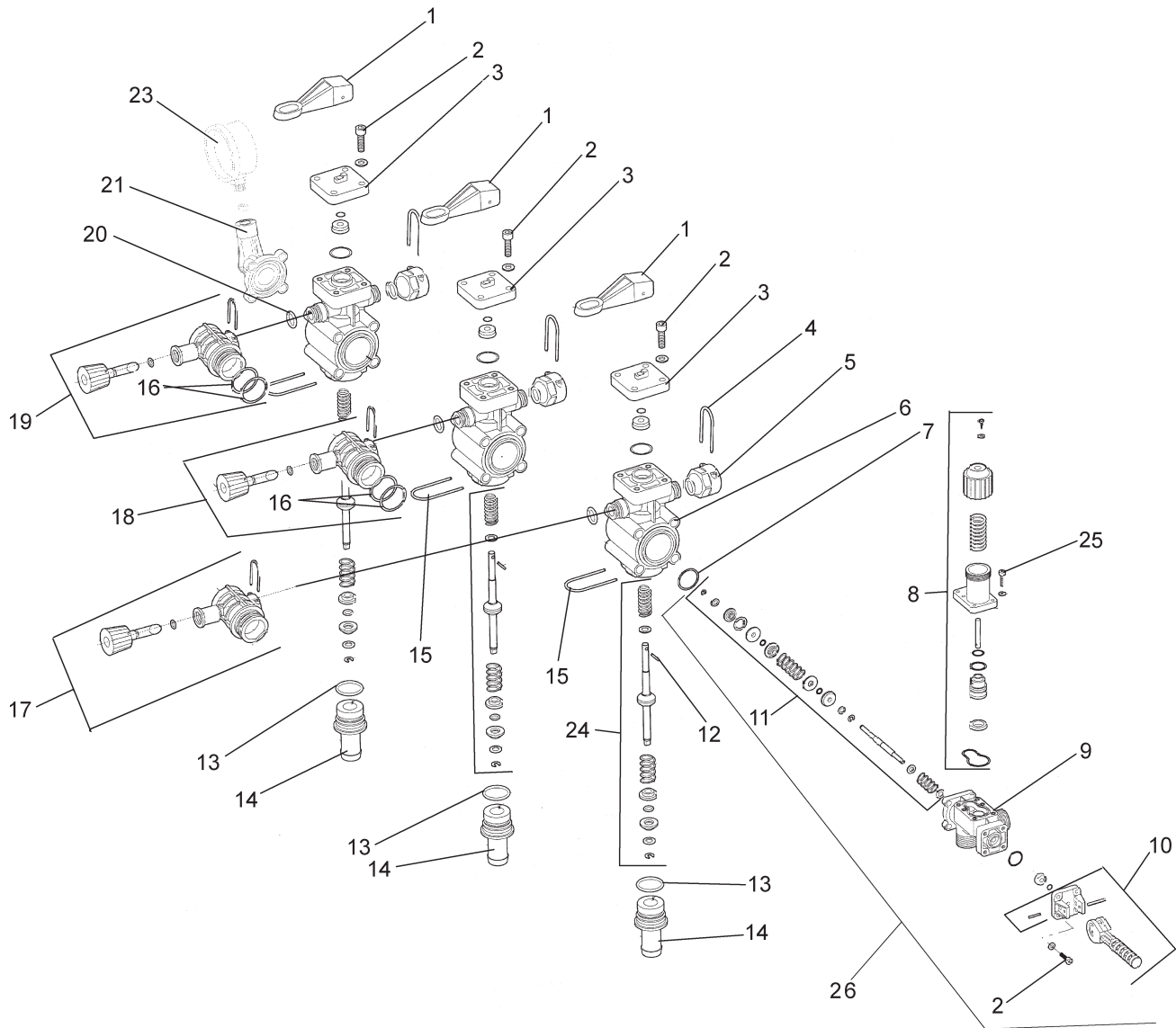

Accessories

10-648 3-WAY MANUAL VALVE PARTS LIST

REF#	PART#	DESCRIPTION	QUANTITY
1	10-268-07	Boom Lever	3
2	10-268-28	Bolt and Washer	18
3	10-268-17	Boom Lever Plate	3
4	10-268-06	Spring Clip $\frac{5}{8}$	6
5	10-268-05	Cap	3
	10-268-21	O-Ring (included with 10-268-19 Seal Kit)	3
6	10-268-02	Main Body	3
	10-268-19	Seal Kit	1 per body
7	10-268-24	O-Ring for Main Body	3
8	10-268-27	Main Pressure Adjust	1
9	10-268-29	Pressure Adjust Body	1
10	10-268-09	Main Boom Lever	1
11	10-268-30	Master Boom Lever Guts	1
12	10-268-25	Boom Lever Pin	3
13	10-268-22	O-Ring (included with 10-268-19 Seal Kit)	3
14	10-268-03	Hose Barb $\frac{3}{4}$	3
15	10-268-04	Spring Clip $\frac{7}{8}$	3
16	10-268-23	O-Ring (included with 10-268-12 and 10-268-14)	4
17	10-268-11	Boom Pressure Adjust (threaded end)	1
18	10-268-12	Boom Pressure Adjust (middle)	1
19	10-268-14	Boom Pressure Adjust (capped)	1
20	10-268-21	O-Ring	3
21	10-268-01	Gauge Elbow	1
22	10-268-13	Elbow 90° 1" Hose Barb with Nut	3
23	16-281	Liquid Filled Gauge (not part of 10-268)	1
24	10-268-26	Plunger Assembly	3
25	10-268-28	Bolt & Washer	6
26	10-168-31	Manual Control Valve	1
27	10-268-32	1" Elbow	1
	10-268-33	Clip	1
28		1" Hose Barb	1
Not Shown	10-268-15	Tie Rod with Nuts and Washer	4

1102 PLUMBING DRAWING (TEEJET® RADION 8140)

15-817

O-ring for 50 Series Clamp

15-818 O-ring for 75 Series Clamp

BOOM
15' OR 18'

LEFT HOSE
9032-89

CENTER HOSE
9032-65

RIGHT HOSE
9032-113

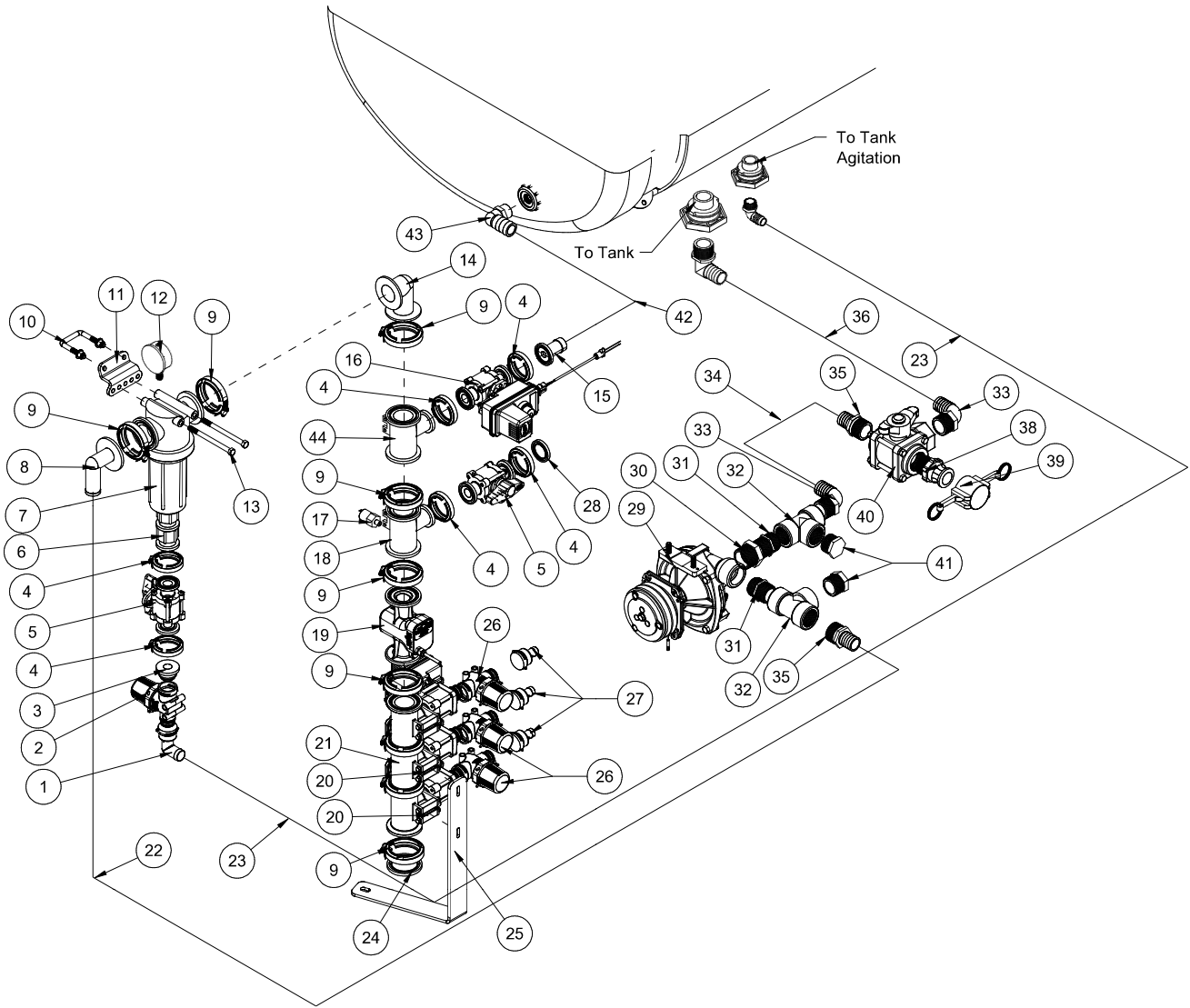

ACCESSORIES

1102 PLUMBING PARTS LIST (TEEJET® RADION 8140)

REF#	PART#	DESCRIPTION	QUANTITY
1	14-671	Elbow	1
2	14-801	Agitator Line Strainer, 50 Mesh	1
	14-802	Replacement 50 Mesh Screen	
	14-803	Decal, Clean Strainer	1
3	15-825	#50 Male Quick Coupler	1
4	15-740	#50 Series Clamp	6
5	15-738	Flanged Ball Valve	2
6	15-735	#50 x 1 FTP Fitting	1
7	15-737	Flanged Strainer	1
	16-968-03	Screen (50 mesh)	1
8	15-739	#75 90° Hose Barb	1
9	15-741	#75 Series Clamp	7
10	17-537	Square U-bolt	1
11	30-551	Filter Mount	1
12	16-281	Liquid Filled Gauge	1
13	HB-38-16-500	Hex Bolt, 3/8 - 16 x 5	2
	HNFL-38-16	Flange Whiz-loc Nut, 3/8 - 16	2
14	15-734	#75 Elbow Coupling	1
15	15-870	#50 x 1 1/4 HB	1
16	20-785	Regulator Valve	1
17	20-670-04	Radion Pressure Sensor	1
18	30-164	Tapped Reducer Tee	1
19	30-590	Electromagnetic Flow Meter	1
20	15-743-03	Mounting Rail	2
	15-743-06	Screw, SS	8
21	15-743	Manifold Valve	1
22	8897	1 1/4" Discharge Hose	61"
	18-116	Hose Clamp	2
23	8896	1" Suction Hose	54"
	18-222	Hose Clamp	2
24	15-742	#75 Inlet Cover	1
25	20-976	Valve Brace	1
26	14-607	Strainer, QC 100 Mesh	3
27	14-660	3/4 Quick Connect Hose Barb	3
28	15-778	Blank Gauge Port Flange	1
29	15-984	Hypro® Pump	1
30	16-825	Hex Bushing	1
31	16-880	Nipple	2
32	18-390	Tee	2
33	16-156	Elbow	2
34	8897	1 1/4" Discharge Hose	20"
	18-116	Hose Clamp	2
35	16-161	Fitting	2
36	8897	1 1/4" Discharge Hose	18"
	18-116	Hose Clamp	2
38	16-180	Quick Coupler Male	1
39	16-935	Quick Coupler Cap	1
40	18-372	3-Way Valve	1
	18-372-01	T-Handle	1
41	10-389	Plug	2
42	8897	1 1/4" Discharge Hose	28"
	18-116	Hose Clamp	2
43	15-779	Elbow, 1 x 1 1/4 HB	1
44	15-775	Reducer Tee	1

1104 PLUMBING DRAWING (TEEJET® 744)

15-817 O-ring for 50 Series Clamp

15-818 O-ring for 75 Series Clamp

BOOM	LEFT HOSE	CENTER HOSE	RIGHT HOSE
15' OR 18'	9032-89	9032-65	9032-113

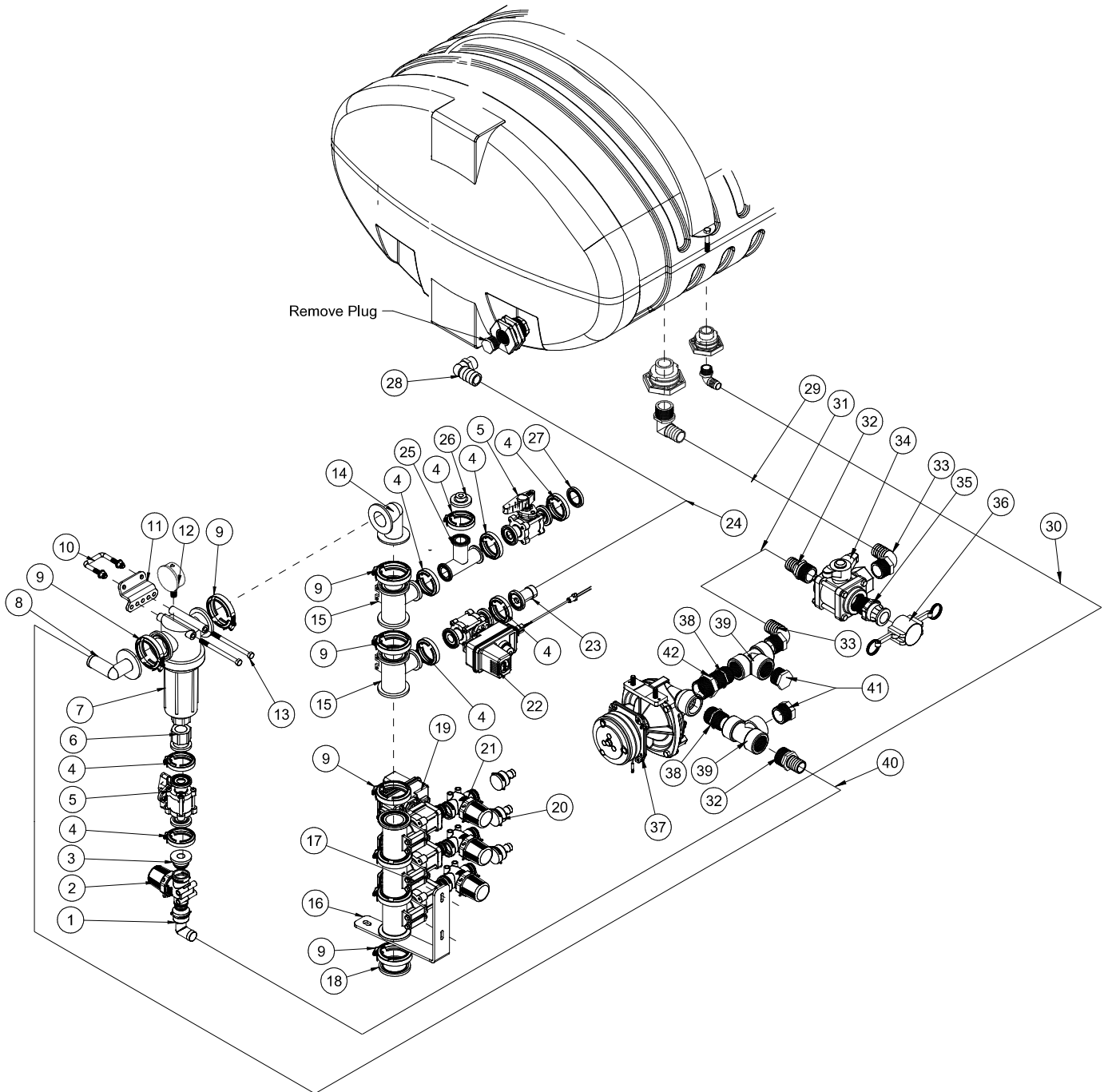

IMPORTANT

If using Simulated Speed with a Radion 8140, one needs to change back to Ground Speed for proper rate control when spraying.

Accessories

1104 PLUMBING PARTS LIST (TEEJET® 744)

REF#	PART#	DESCRIPTION	QUANTITY
1	14-671	Elbow	1
2	14-801	Agitator Line Strainer, 50 Mesh	1
	14-802	Replacement 50 Mesh Screen	
	14-803	Decal, Clean Strainer	1
3	15-825	#50 Male Quick Coupler	1
4	15-740	#50 Series Clamp	8
5	15-738	Flanged Ball Valve	2
6	15-735	#50 x 1 FTP Fitting	1
7	15-737	Flanged Strainer	1
	16-968-03	Screen (50 mesh)	1
8	15-739	#75 90° Hose Barb	1
9	15-741	#75 Series Clamp	6
10	17-537	Square U-bolt	1
11	30-551	Filter Mount	1
12	16-281	Pressure Gauge	1
13	HB-38-16-500	Hex Bolt, 3/8 - 16 x 5	2
	HNFL-38-16	Flange Whiz-loc Nut, 3/8 - 16	2
14	15-734	#75 Elbow Coupling	1
15	15-775	Reducer Tee	2
16	20-916	Valve Brace	1
17	15-743-03	Mounting Rail	2
	15-743-06	Screw, SS	8
18	15-742	#75 Inlet Cover	1
19	15-743	Manifold Ball Valve	1
20	14-660	3/4 Quick Connect Hose Barb	3
21	14-607	Strainer, QC 100 Mesh	3
22	20-817	Regulating Valve	1
23	15-870	#50 1 1/4 Hose Barb	1
24	8897	1 1/4" Discharge Hose	26"
	18-116	Hose Clamp	2
25	15-776	#50 Tee	1
26	15-777	Gauge Port Flange	1
27	15-778	Blank Gauge Port Flange	1
28	15-779	Hose Barb (remove plug)	1
29	8897	1 1/4" Discharge Hose	18"
	18-116	Hose Clamp	2
30	8896	1" Suction Hose	54"
	18-222	Hose Clamp	2
31	8897	1 1/4" Discharge Hose	20"
	18-116	Hose Clamp	2
32	16-161	Fitting	2
33	16-156	Elbow	2
34	18-372	3-Way Valve	1
	18-372-01	T-Handle	1
35	16-180	Quick Coupler Male	1
36	16-935	Quick Coupler Cap	1
37	15-984	Hypro® Pump	1
38	16-880	Nipple	2
39	18-390	Tee	2
40	8897	1 1/4" Discharge Hose	56"
	18-116	Hose Clamp	2
41	10-389	Plug	2
42	16-973	Hex Bushing	1

1102 SYSTEM WIRING (TEEJET® RADION)

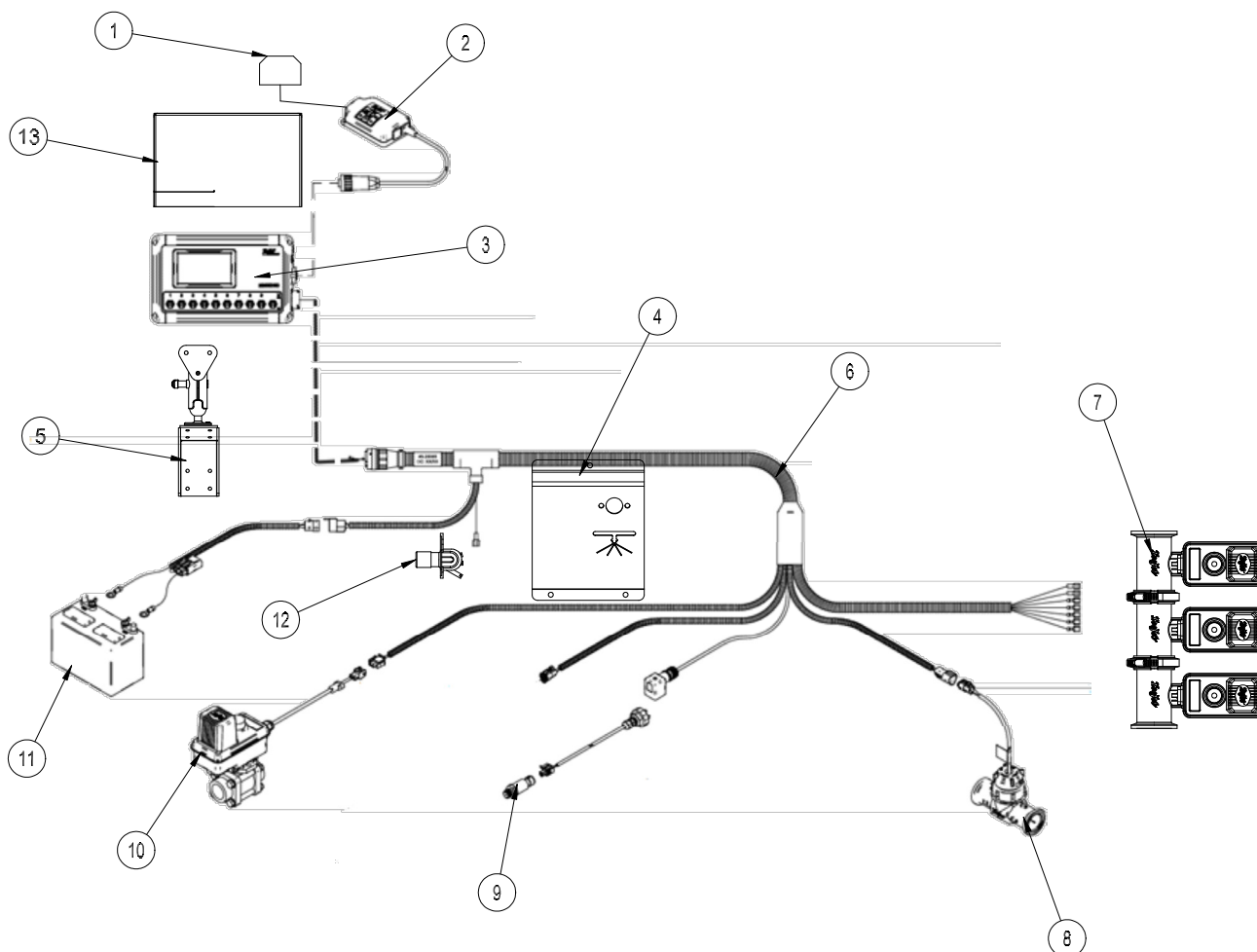

▲ IMPORTANT

If using Simulated Speed with a Radion 8140, one needs to change back to Ground Speed for proper rate control when spraying.

Accessories

REF#	PART#	DESCRIPTION	QUANTITY
1*		Antenna	1
2*	20-687-02	GPS Speed Sensor	1
3*	20-697-01	Radion 8140 Console	1
4	10-705	Foot Plate	1
5	10-721	Mount Bracket	1
6*		Wire Harness	1
7	15-743	Manifold Valve	1
8*	30-590	Electromagnetic Flow Meter	1
9*	20-670-04	Pressure Sensor	1
10	20-785	Regulator Valve	1
11	33-216	Battery	1
12	33-509	Master Boom Control	1
13	20-781	Plastic Radion Cover	1
*	20-927	TeeJet® Radion Kit EM(includes * items)	1
NS	33-508	Auto Blade Fuse 15AMP	1
NS	33-562	Auto Blade Fuse 40AMP	1

1104 SYSTEM WIRING (TEEJET® 744)

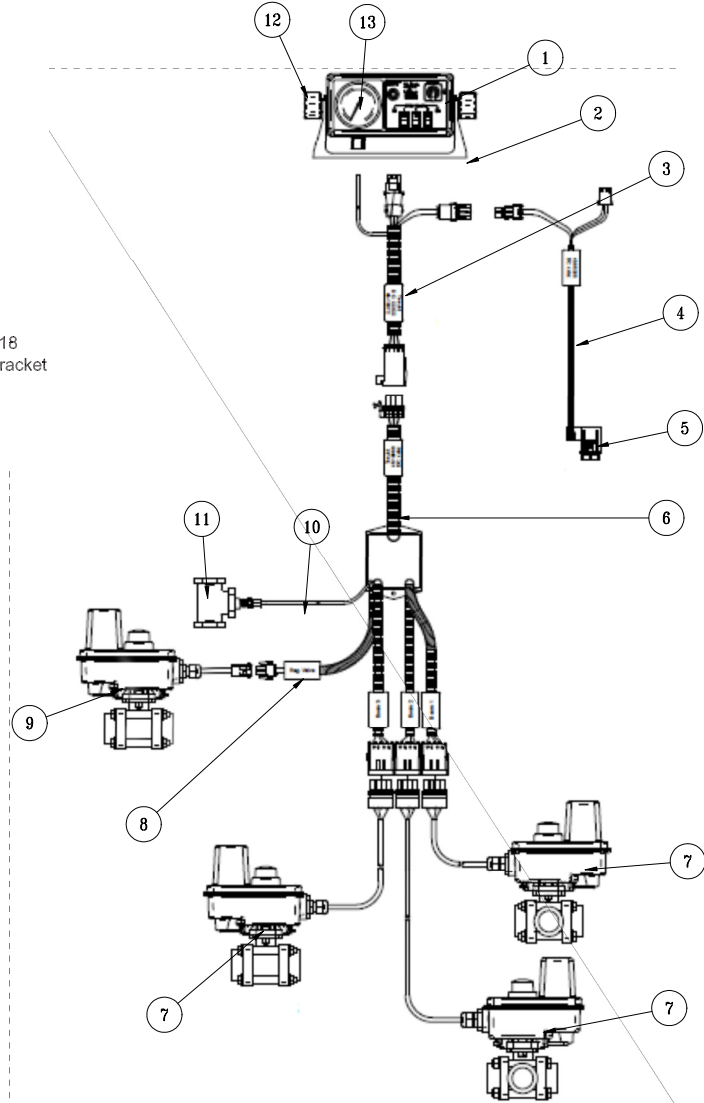
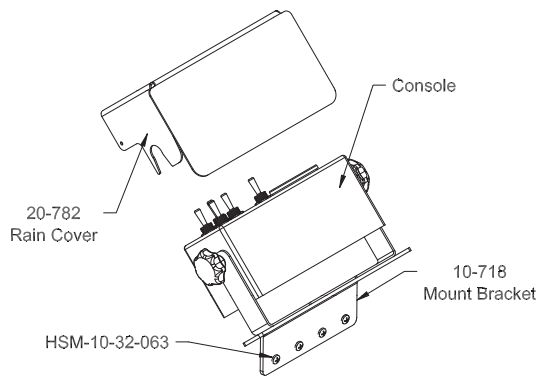

REF#	PART#	DESCRIPTION	QUANTITY
1*	20-688-02	744A Console	1
1*	20-688-02	744A Console	1
	20-688-07	Circuit Board	1
	20-688-08	Gauge Elbow	1
	15-314	Replacement Master Switch	
2	10-718	Mount Bracket	1
3*		Console harness	1
4*		Fused Power Cable	1
5	33-271	Fuse Block	1
6*		Ball Valve Wire Harness	1
7	15-743	Manifold Ball Valve	1
8*		Regulator Valve Adapter	1
9	20-817	Regulating Valve	1
10*	20-688-04	Tubing	1
11	15-776	Tee	1
12*	20-688-09	Mounting Knob	2
13*	20-688-01	PSI Liquid Gauge	1
*	20-688	744A Kit Complete (includes * items)	

CONTROL MOUNTS

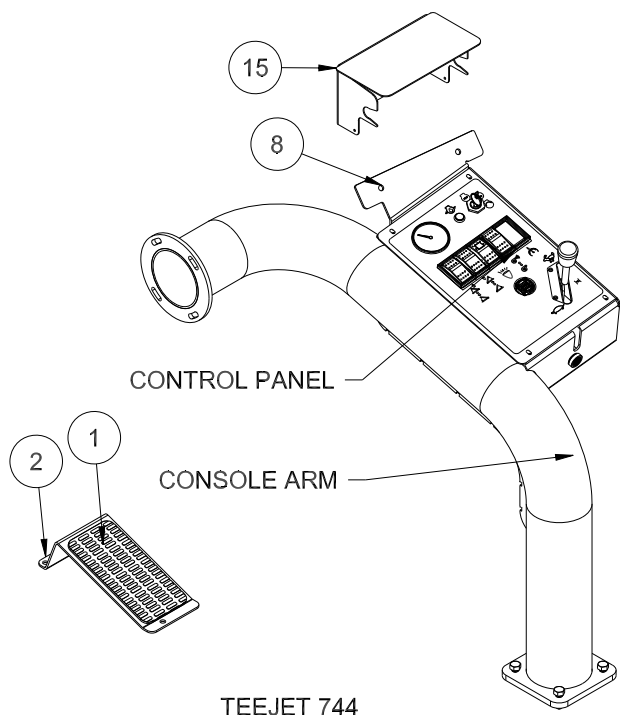

TEEJET 744

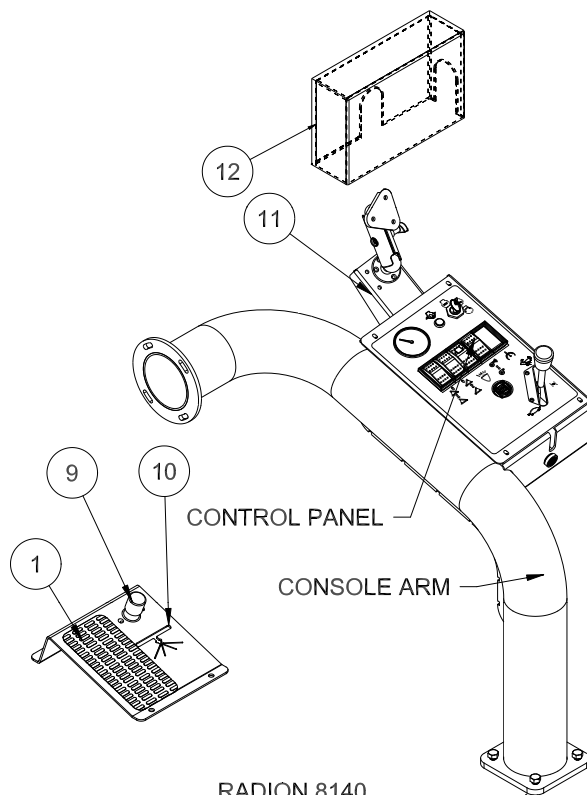

RADION 8140

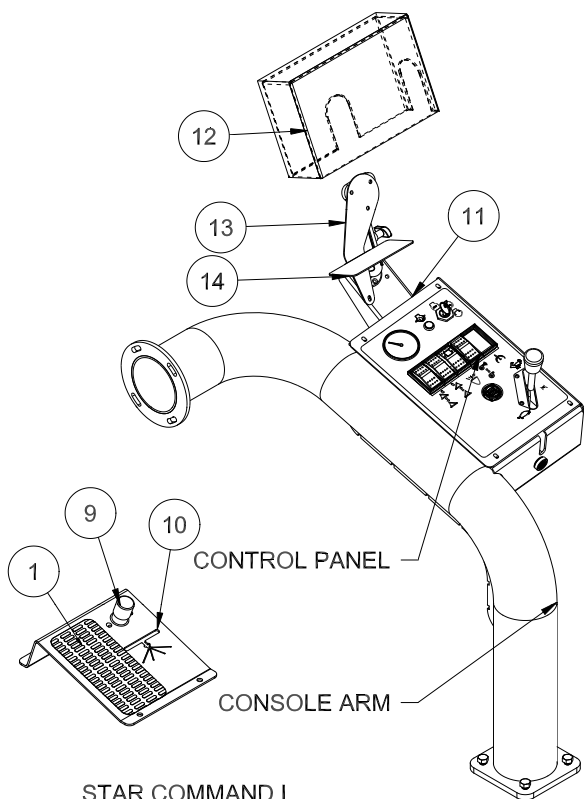

STAR COMMAND I

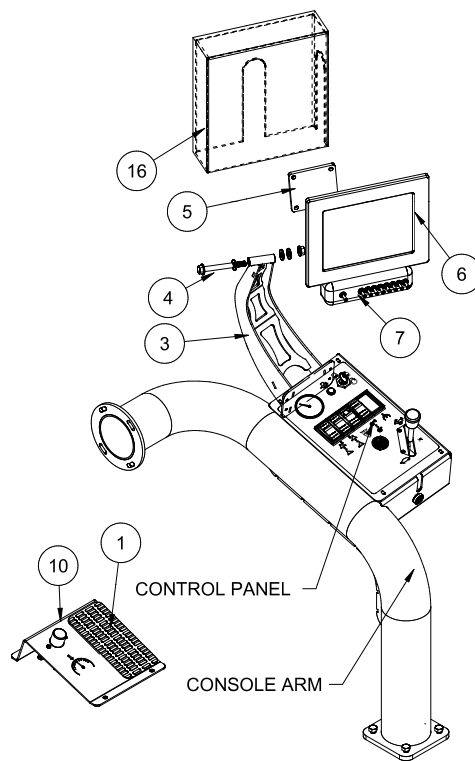

STAR COMMAND II

CONTROL MOUNTS

REF#	PART#	DESCRIPTION	QUANTITY
1	45-132	Foot Rest Grip	1
2	45-047	Foot Rest	1
3	20-986	16" Screen Mount Arm	1
	HSM-10-32-063	Machine Screw, #10 -32 x 5/8	4
	HNFL-10-32	Flange Whiz-loc Nut, 10-32	4
4	HB-38-16-350	Hex Bolt, 3/8 - 16 x 3 1/2	1
	HW-516	Flat Washer, 5/16	4
	HNTL-38-16	Lock Nut, 3/8 - 16	1
5	20-940	Screen Mount	1
6	20-985	16" Ag Leader® Display	1
7		Ag Leader® Switch	1
8	10-718	744 Control Mount	1
9	33-509	Master Boom Switch	1
10	10-705	Switch Foot Plate	1
11	10-721	Short Ram Mount	1
12	20-781	Cover for Radion Control	1
13	10-719	Star Command I Control Mount	1
14	10-716	DynaJet Control Cover	1
15	20-782	744 Cover	1
16	20-984	16" Ag Leader Display Cover	1

1105/1108 DRAWING

15-817 O-ring for 50 Series Clamp

15-818 O-ring for 75 Series Clamp

BOOM

LEFT HOSE

CENTER HOSE

RIGHT HOSE

15' OR 18'

9032-89

9032-65

9032-113

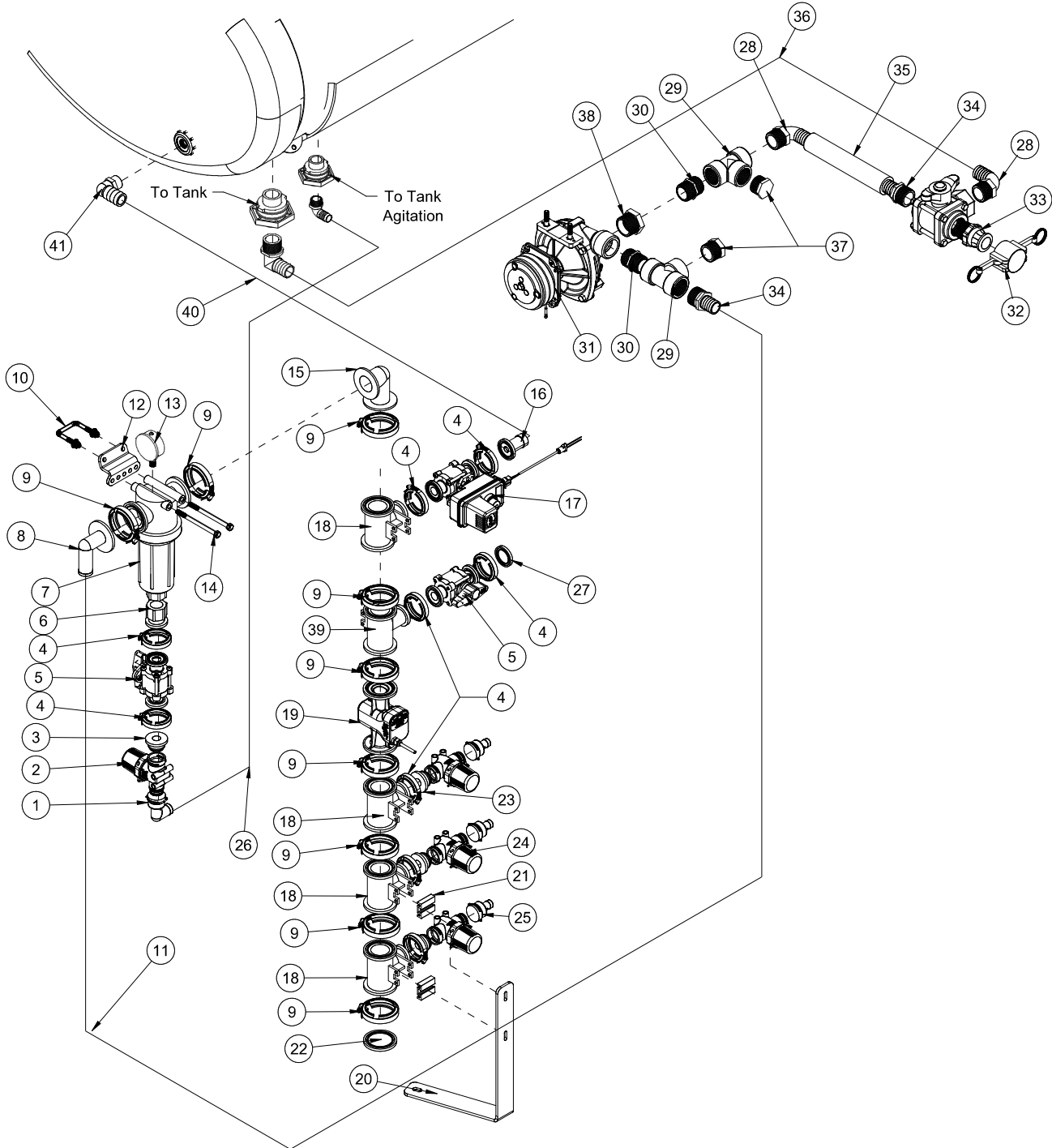

Accessories

1105/1108 PARTS LIST

REF#	PART#	DESCRIPTION	QUANTITY
1	14-671	Elbow	1
2	14-801	Agitator Line Strainer, 50 Mesh	1
	14-802	Replacement 50 Mesh Screen	
	14-803	Decal, Clean Strainer	1
3	15-825	#50 Male Quick Coupler	1
4	15-740	#50 Series Clamp	9
5	15-738	Flanged Ball Valve	2
6	15-735	#50 x 1 FTP Fitting	1
7	14-628	Flanged Strainer with 80 Mesh screen	1
	16-968-03	Screen (50 mesh)	1
8	15-739	#75 90° Hose Barb	1
9	15-741	#75 Series Clamp	9
10	17-537	Square U-bolt	1
11	8897	1 ¹ / ₄ " Discharge Hose	61"
	18-116	Hose Clamp	2
12	30-551	Filter Mount	1
13	16-281	Liquid Filled Gauge	1
14	HB-38-16-500	Hex Bolt, ³ / ₈ - 16 x 5	2
	HNFL-38-16	Flange Whiz-loc Nut, ³ / ₈ - 16	2
15	15-734	#75 Elbow Coupling	1
16	15-870	#50 x 1 ¹ / ₄ HB	1
17	20-785	Regulator Valve	1
18	15-775	Reducer Tee	4
19	30-590	Electromagnetic Flow Meter	1
20	20-976	Valve Brace	1
21	15-743-03	Mounting Rail	2
	15-743-06	SS Screw	8
22	15-742	#75 Inlet Cover	1
23	15-825	#50 Male Quick Coupler	3
24	14-607	QC Strainer 100 Mesh	3
	14-609	Replacement 100 Mesh Screen	
25	14-660	³ / ₄ Quick Connect Hose Barb	3
26	8896	1" Suction Hose	54"
	18-220	Hose Clamp	2
27	15-778	Blank Gauge Port Flange	1
28	16-156	Elbow	2
29	18-390	Tee	2
30	16-880	Nipple	2
31	15-984	Hypro® Pump	1
32	16-935	Quick Coupler Cap	1
33	16-180	Quick Coupler Male	1
34	16-161	Fitting	2
35	8897	1 ¹ / ₄ " Discharge Hose	20"
	18-116	Hose Clamp	2
36	8897	1 ¹ / ₄ " Discharge Hose	18"
	18-116	Hose Clamp	2
37	10-389	Plug	2
38	16-973	Hex Bushing	1
39	30-164	Tapped Reducer Tee	1
	20-670-04	Pressure Sensor	1
40	8897	1 ¹ / ₄ " Discharge Hose	28"
	18-116	Hose Clamp	2
41	15-779	Elbow 1 x 1 ¹ / ₄ HB	1

1105/1108 MODULE MOUNTS

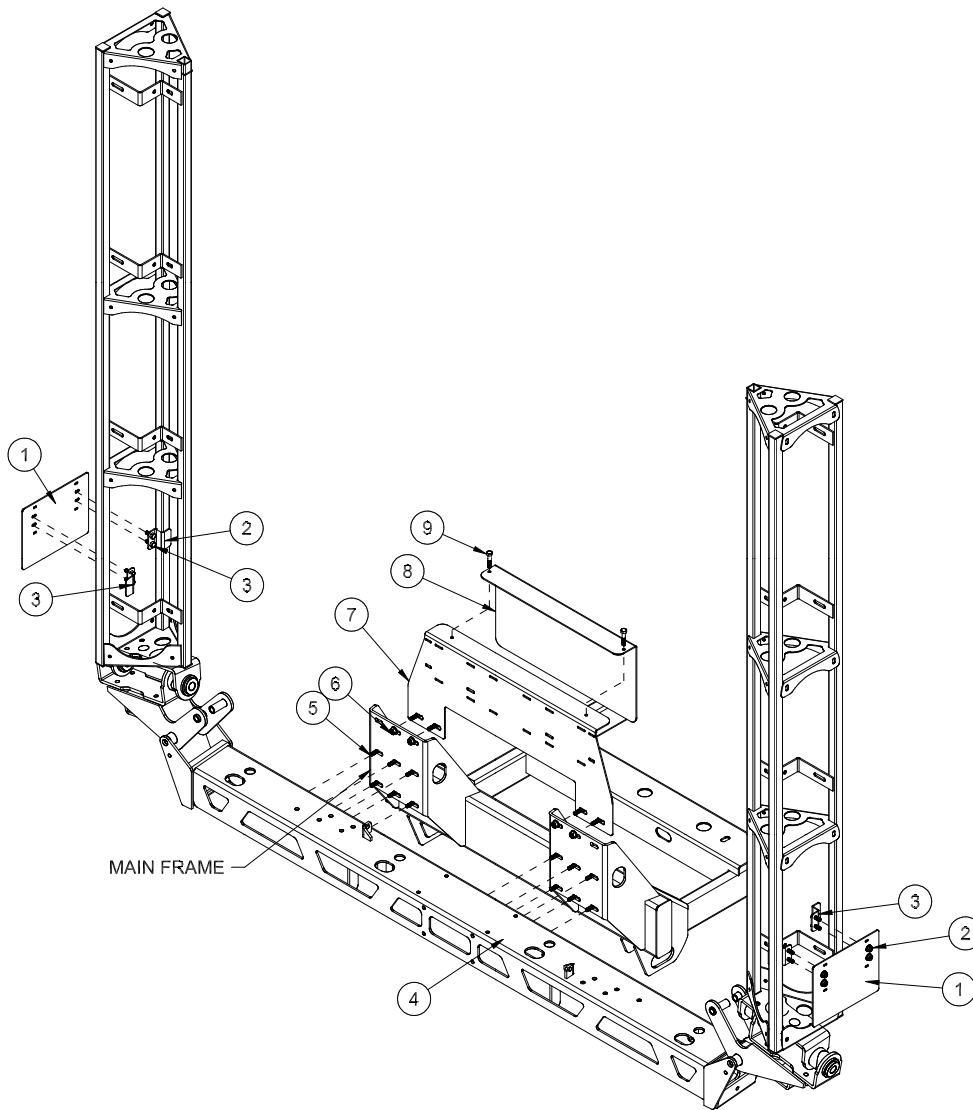

REF#	PART#	DESCRIPTION	QUANTITY
1	20-665	Drive Module Bracket	2
2	20-664	Z Bracket	4
3	HSTP-14-20-075	Machine Screw, $\frac{1}{4}$ - 20 x $\frac{3}{4}$	10
	HNFL-14-20	Flange Whiz Lock Nut, $\frac{1}{4}$ - 2	10
4		Center Boom Mount	1
5	HB-38-16-125	Bolt, $\frac{3}{8}$ - 16 x $1\frac{1}{4}$	12
	HW-38	Flat Washer, $\frac{3}{8}$	12
	HW-5/16	Flat Washer, $\frac{5}{16}$	12
	HNFL-516-18	Flange Whiz Lock Nut, $\frac{3}{8}$ -16	12
6	HB-38-16-125	Bolt, $\frac{3}{8}$ - 16 x $1\frac{1}{4}$	4
	HW-3/8	Flat Washer, $\frac{3}{8}$	4
	HNFL-516-18	Flange Whiz Lock Nut, $\frac{3}{8}$ -16	4
7	30-577	Module mount Bracket	1
8	20-920	Module Cover Bracket	1
9	HB-516-18-150	Hex Bolt, $\frac{5}{16}$ -18 x $1\frac{1}{2}$	2
	HNFL-516-18	Flange Whiz-loc Nut, $\frac{5}{16}$ -18	2

10-716-M

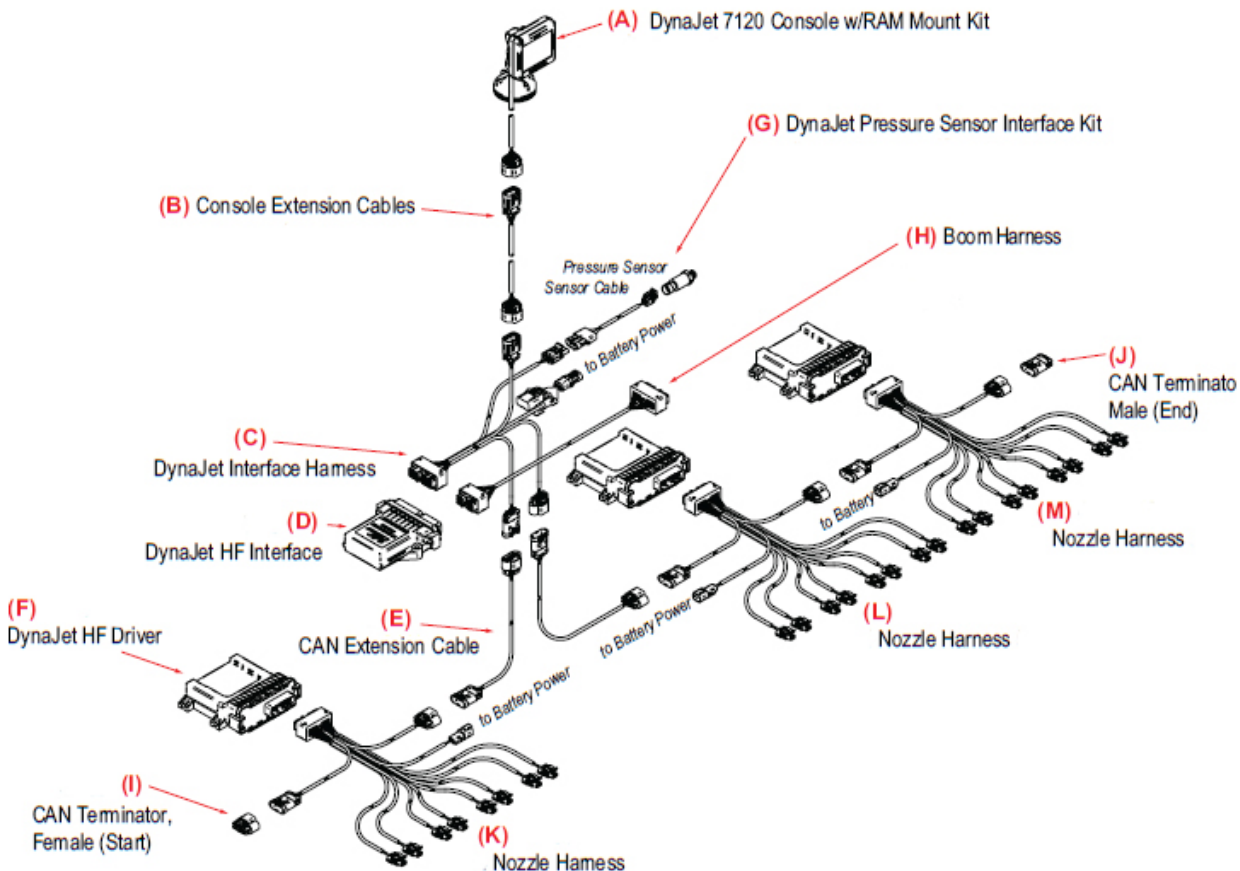

REF#	PART#	DESCRIPTION	QUANTITY
A	20-670-06	DynaJet 7120 Console	1
B		Console Extension Cable	1
C		DynaJet Interface Harness	1
D	20-670-07	DynaJet HF Interface	1
E		CAN Extension Cables	1
F	20-670-05	DynaJet HF Driver	3
G	20-670-04	Pressure Sensor	1
		Pressure Sensor Cable	1
H		Boom Harness	1
I	20-670-09	Terminator, Female (Start)	1
J	20-670-08	Terminator, Male (End)	1
K	20-670-01	Left Nozzle Harness	1
L	20-670-02	Center Nozzle Harness	1
M	20-670-03	Right Nozzle Harness	1

20-926 TeeJet® Radion System EM w/ Dynajet

NOTE: This is for 20" spacing used with the Radion system

Accessories

1115-AG/1118-AG PLUMBING DRAWING

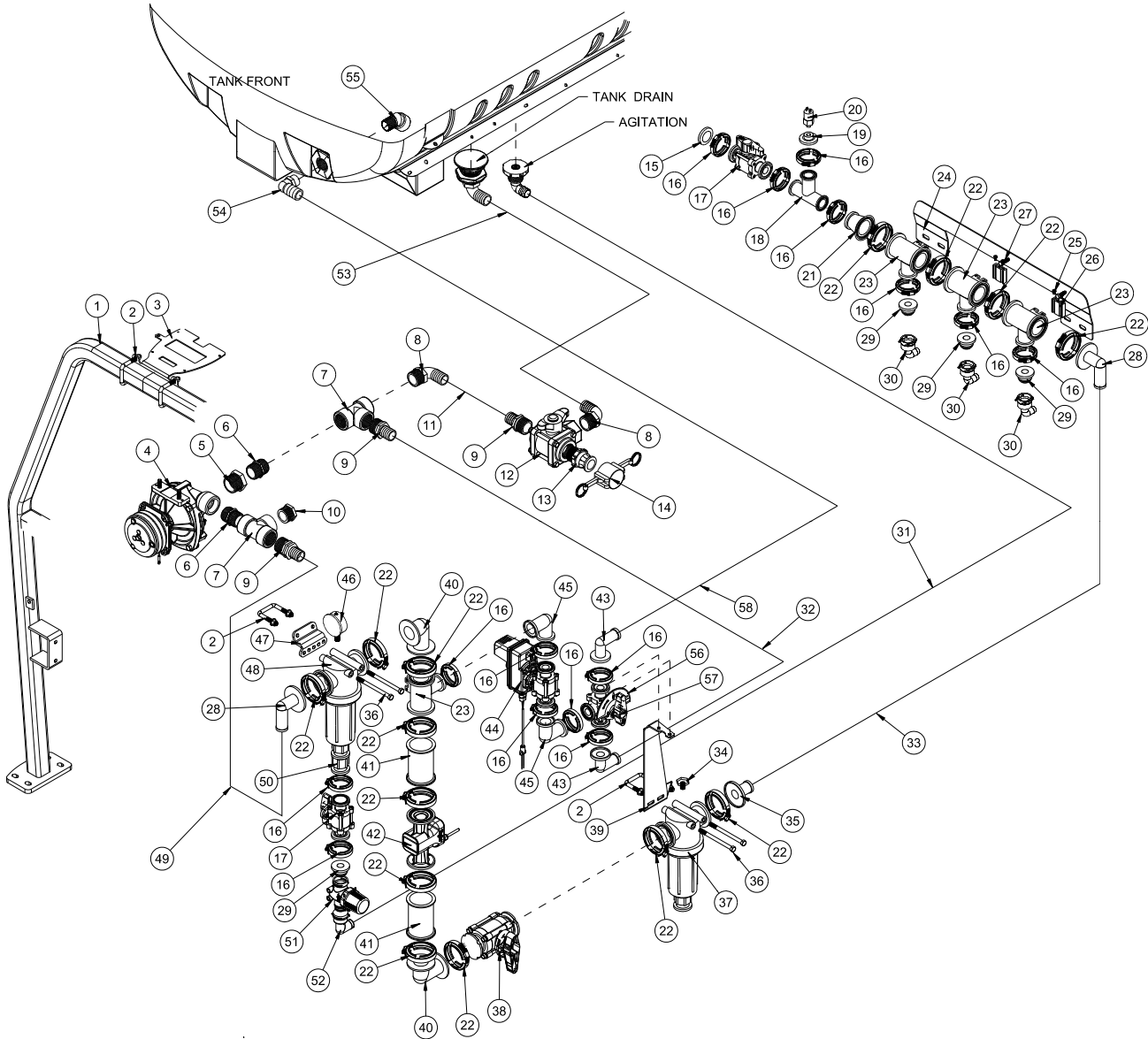

ACCESSORIES

1115-AG/1118-AG PLUMBING PARTS LIST

REF#	PART#	DESCRIPTION	QUANTITY
1	20-886	Roll Bar	1
2	17-537	Square U-bolt	4
	HNFL-38-16	Flange Whiz-loc Nut, 3/8 - 16	8
3	20-770	Antenna Mount	1
	HBM-4-.7-10	Metric Hex Bolt, M4-.7x10	4
4	15-984	Pump	1
5	16-973	Hex Bushing	1
6	16-880	Nipple	2
7	18-390	Tee	2
8	16-156	Elbow	2
9	16-161	Fitting	3
10	10-389	Plug	1
11	8897	1 1/4" Discharge Hose	20"
	18-116	Hose Clamp	2
12	18-372	3-Way Valve	1
	18-372-01	T-Handle	1
13	16-180	Quick Coupler Male	1
14	16-935	Quick Coupler Cap	1
15	15-778	Blank Gauge Port Flange	1
16	15-740	#50 Series Clamp	12
17	15-738	Flanged Ball Valve	2
18	15-776	#50 Tee	1
19	15-777	Gauge Port Flange	1
20		Pressure Sensor	1
21	15-748	Reducer Coupling (#75 to #50)	1
22	15-741	#75 Series Clamp	14
23	15-775	Reducer Tee	4
24	20-941	Manifold Mount	1
25	15-743-06	SS Screw	8
26	15-743-03	Mounting Rail	2
27	HB-516-18-075	Hex Bolt, 5/16 -18 x 3/4	2
	HNFL-516-18	Flange Whiz-loc Nut, 5/16 -18	2
28	15-739	#75 90° Hose Barb	2
29	15-825	#50 Male Quick Coupler	4
30	15-553	3/4 - 90° Quick Connect Hose Barb	3
31	8896	1" Discharge Hose	54"
	18-222	Hose Clamp	2
32	8897	1 1/4" Discharge Hose	43"
	18-116	Hose Clamp	2
33	8897	1 1/4" Discharge Hose	56"
	18-116	Hose Clamp	2
34	15-780	Plug	1
35	15-744	#75 x 1 1/4 Hose Barb	1
36	HB-38-16-500	Hex Bolt, 3/8 - 16 x 5	4
	HNFL-38-16	Flange Whiz-loc Nut, 3/8 - 16	4
37	14-805	Flanged Strainer with 100 Mesh screen	1
	16-968-06	Screen (100 Mesh)	
38	14-806	2-Way Shut Off Valve	1
39	20-982	Valve/Filter Bracket	1

1115-AG/1118-AG PLUMBING DRAWING

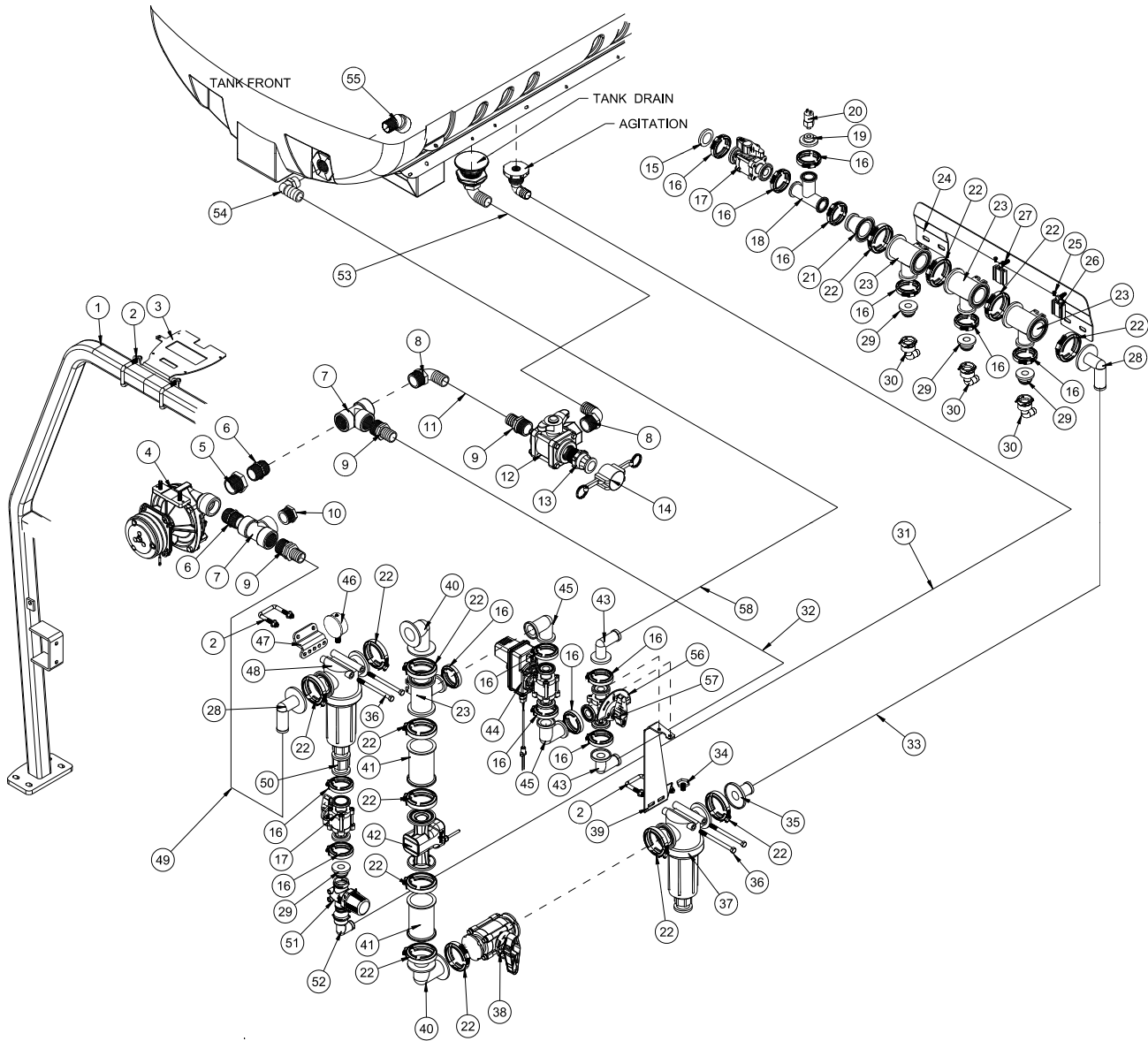

Accessories

1115-AG/1118-AG PLUMBING PARTS LIST

REF#	PART#	DESCRIPTION	QUANTITY
40	15-734	#75 Elbow Coupling	2
41	15-881	#75 Straight Coupling	2
42	30-590	EM Flowmeter	1
43	15-976	#50 x 90° x 1¼ Hose Barb	2
44	20-785	Regulator Valve	1
45	15-736	#50 Flange Coupling	2
46	16-281	Liquid Filled Gauge	1
47	30-551	Filter Mount	1
48	14-628	Flanged Strainer with 80 Mesh screen	1
	16-968-05	Screen (80 mesh)	1
50	15-735	#50 x 1 FTP Fitting	1
49	8897	1¼" Discharge Hose	61"
	18-116	Hose Clamp	2
51	14-801	Agitator Line Strainer, 50 Mesh	1
	14-802	Replacement 50 Mesh Screen	
	14-803	Decal, Clean Strainer	1
52	14-671	Elbow	1
53	8897	1¼" Discharge Hose	18"
	18-116	Hose Clamp	2
54	15-779	Fitting, 1 x 1-1/4 HB	1
55	16-971	45° Fitting	1
56	20-983	Decal Plate	1
	25-391	Decal, Spray Pump Prime	1
57	15-988	3-way Flanged valve	1
58	8897	1¼" Discharge Hose	29"
	18-116	Hose Clamp	2

1115-AG/1118-AG MODULE MOUNTS

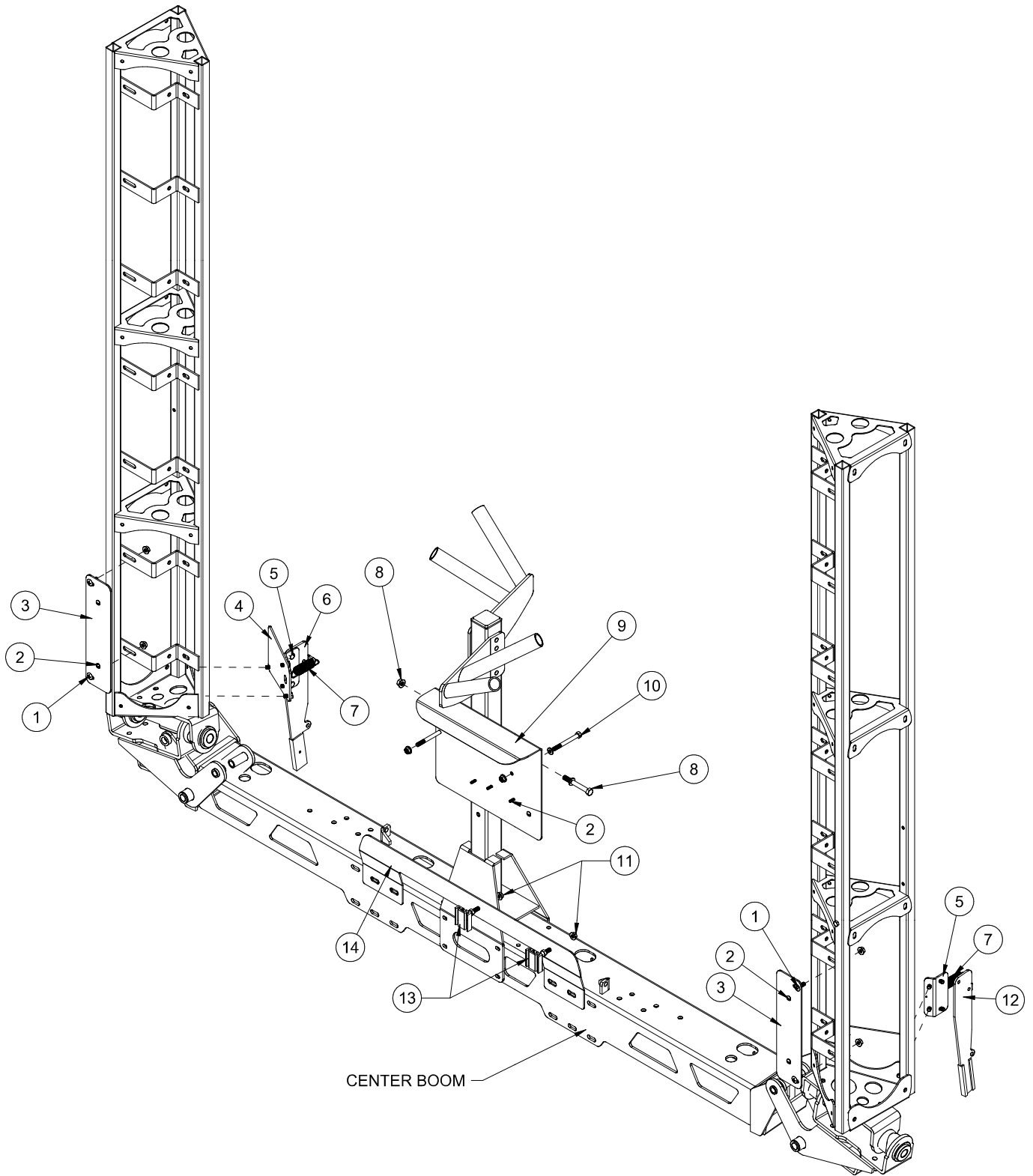

Accessories

1115-AG/1118-AG MODULE MOUNTS

REF#	PART#	DESCRIPTION	QUANTITY
1	HSTP-516-18-075	Truss Head Screw, $\frac{5}{16}$ -18 x $\frac{3}{4}$	4
	HNFL-516-18	Flange Whiz-loc Nut, $\frac{5}{16}$ -18	4
2	HSM-10-32-063	Machine Screw, #10 -32 x $\frac{5}{8}$	4
	HNFL-10-32	Flange Whiz-loc Nut, #10-32	4
3	20-942	Boom Controller Mount	2
4	17-559	Break-Away Mount	2
5	17-560	Hinge Mount	2
6	17-562	LH Break-Away Arm	1
	8946-3.5	Plastic Wear Strip	1
	HRS-316-050	Rivet, $\frac{3}{16}$ x $\frac{1}{2}$	1
7	11-050	Spring	2
8	HB-38-16-300	Hex Bolt, $\frac{3}{8}$ - 16 x 3	1
	HW-516	Flat Washer, $\frac{5}{16}$	1
	HNFL-38-16	Flange Whiz-loc Nut, $\frac{3}{8}$ - 16	1
9	20-943	Module Mount	1
10	HB-516-18-300	Hex Bolt, $\frac{5}{16}$ -18 x 3	2
	HW-14	Flat Washer, $\frac{1}{4}$	4
	HNFL-516-18	Flange Whiz-loc Nut, $\frac{5}{16}$ -18	2
11	HB-516-18-075	Hex Bolt, $\frac{5}{16}$ -18 x $\frac{3}{4}$	2
	HNFL-516-18	Flange Whiz-loc Nut, $\frac{5}{16}$ -18	2
12	17-561	RH Break-Away Arm	1
	8946-3.5	Plastic Wear Strip	1
	HRS-316-050	Rivet, $\frac{3}{16}$ x $\frac{1}{2}$	1
13	15-743-03	Mounting Rail	2
14	20-941	Manifold Mount	1

CAN SWITCH BOX PARTS LIST

REF#	PART#	DESCRIPTION	QUANTITY
1	20-933-06	InCommand Display Power Cable, V2	1
2		GPS Cable	1
3		SC110 Breakout	1
4		CAN. High Current Extension	1
5		Y-Splice, 4-Pin	2
6	20-933-03	Flow Control Harness	1
7		RightSpot Hub CAN Interface	1
8		RightSpot Hub High Current Power	1
9	20-933-01	Pressure Sensor	1
10		Gen 2 CAN A/ Local Breakout	1
11		RightSPot Sync Cable	1
12		Plug, 4-Pin	1
13		Terminator Plug	1
14		Dust Plug, 6-Pin	1
15		Dust Plug, 12-Pin	1
16		Terminating Receptacle	1
17		L2 Module	1
18		CAN Switch Box kit	1
19	20-985	16" Display Bundle	1
20	20-785	Regulating Valve	1
21	30-590	EM Flow Meter	1
22	20-933-02	RightSpot Hub	1
23	20-933-05	RightSpot VCM	2
24		RightSpot CAN Extension	2
25	20-944	RightSpot 6 Drops(10" Spacing) (Qty3 for 15' Booms; Qty 4 for 18' and 20' Booms)	3-4
26		Terminator-RightSpot CAN	2
NS	20-933-04	Recirculating Valve Harness	1

RIGHTSPOT DRAWING

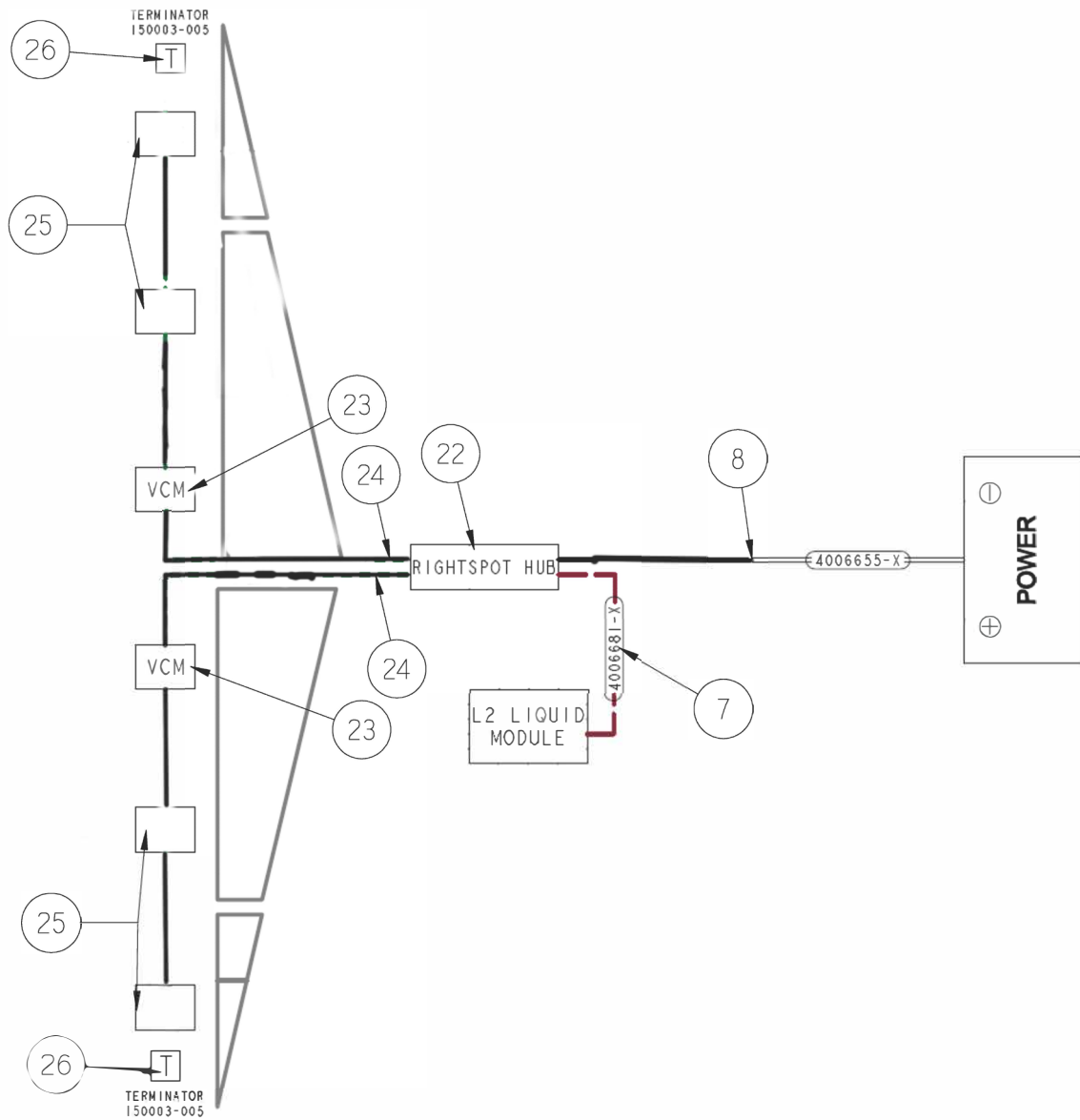

Accessories

RIGHTSPOT PARTS LIST

REF#	PART#	DESCRIPTION	QUANTITY
1	20-933-06	InCommand Display Power Cable, V2	1
2		GPS Cable	1
3		SC110 Breakout	1
4		CAN. High Current Extension	1
5		Y-Splice, 4-Pin	2
6	20-933-03	Flow Control Harness	1
7		RightSpot Hub CAN Interface	1
8		RightSpot Hub High Current Power	1
9	20-933-01	Pressure Sensor	1
10		Gen 2 CAN A/ Local Breakout	1
11		RightSpot Sync Cable	1
12		Plug, 4-Pin	1
13		Terminator Plug	1
14		Dust Plug, 6-Pin	1
15		Dust Plug, 12-Pin	1
16		Terminating Receptacle	1
17		L2 Module	1
18		CAN Switch Box kit	1
19	20-985	16" Display Bundle	1
20	20-785	Regulating Valve	1
21	30-590	EM Flow Meter	1
22	20-933-02	RightSpot Hub	1
23	20-933-05	RightSpot VCM	2
24		RightSpot CAN Extension	2
25	20-944	RightSpot 6 Drops(10" Spacing) (Qty3 for 15' Booms; Qty 4 for 18' and 20' Booms)	3-4
26		Terminator-RightSpot CAN	2

15-988 3-WAY FLANGED BALL VALVE

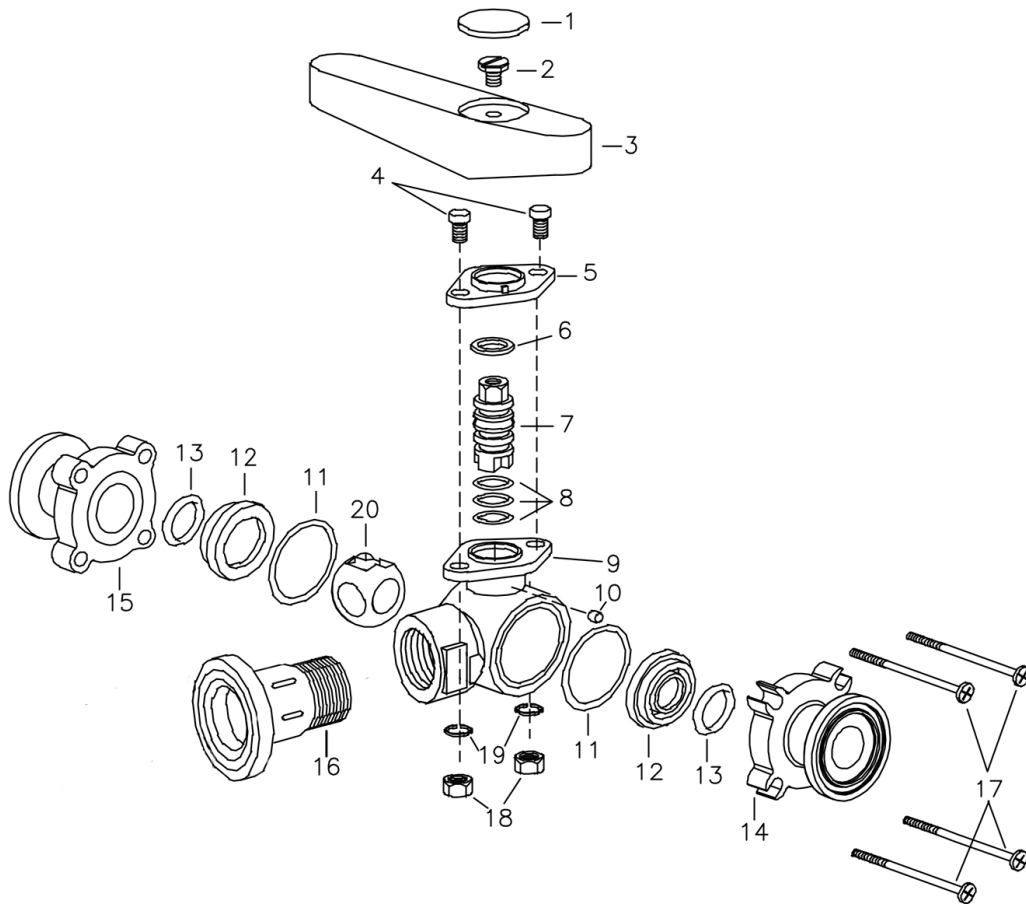

REF#	PART#	DESCRIPTION	QUANTITY
1	10-207-02	Handle Plug	1
2	15-517-10	SS Hex Washer Screw	1
3	10-207-03	Polypropylene Handle	1
4	15-517-04	SS Self Cinching Stud	2
5	10-207-04	Mounting Plate	1
6*	15-517-11	Thrust Washer	1
7*		Ball Valve Stem	1
8*	15-552-05	Viton O-ring	3
9		Nylon Body	1
10*	15-517-17	Dust Plug	1
11*	15-552-13	Viton Gasket	2
12*	15-517-19	Teflon Seal	2
13*	15-517-20	Viton O-ring	2
14		#50 Flanged End Cap	1
15		Flanged End Cap	1
16	15-987	1NPT to #50 End Cap	1
17		SS Pan Head Screw	4
18	15-517-23	SS Hex Nut	2
19	15-517-24	SS Washer	2
20*		Polypropylene Ball	1
*	15-988-01	Spare Parts Kit (includes all * items)	
	15-588	Complete Valve	

15-737/ 14-628/14-805 FLANGED STRAINER

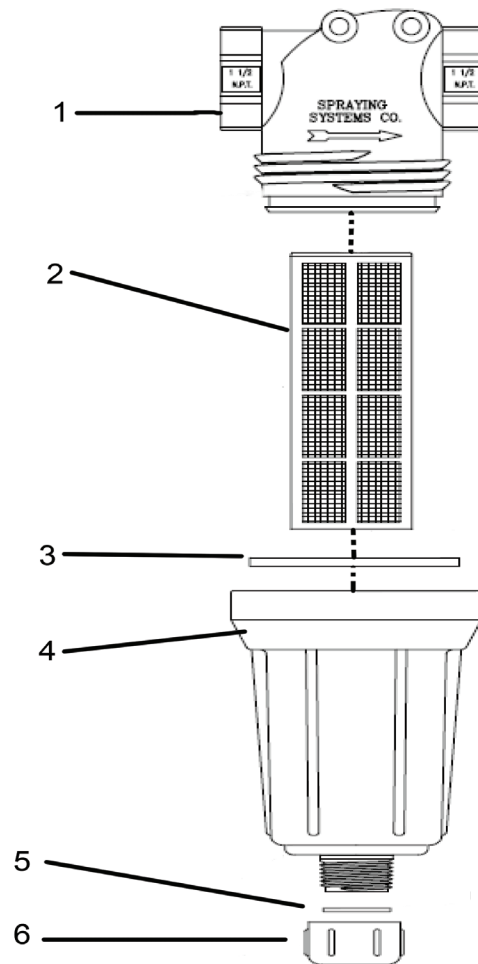

REF#	PART#	DESCRIPTION	QUANTITY
1	15-737-01	Strainer Head 75 Series	1
2*	16-968-03	50 Mesh Screen	1
**	16-968-05	80 Mesh Screen	1
***	16-968-06	100 Mesh Screen	1
3	14-521-02	EPDM Gasket	1
4	14-521-03	Bowl 1" NPT	1
5	14-521-04	EPDM Rubber gasket	1
6	14-521-05	Cap	1

*	15-737	Flanged Strainer Assembly with 50 Mesh Screen
**	14-628	Flanged Strainer Assembly with 80 Mesh Screen
***	14-805	Flanged Strainer Assembly with 100 Mesh Screen

14-801/14-607 STRAINER

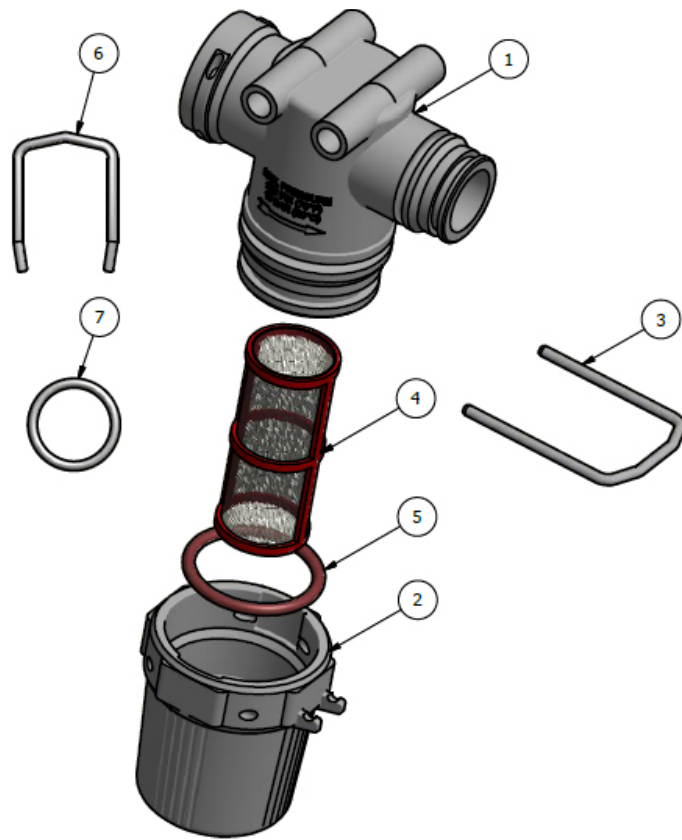

REF#	PART#	DESCRIPTION	QUANTITY
1		QC Strainer Head	1
2	14-801-01	Bowl	1
3		Strainer QC Retaining Clip	1
4*	14-802	50 Mesh Screen	1
**	14-609	100 Mesh Screen	1
5	14-801-02	Viton O-ring	1
6	15-553-01	Retaining Clip	1
7	15-553-02	Viton O-ring	1
*	14-801	Agitation Strainer Assembly with 50 Mesh Screen	
**	14-607	QC Strainer Assembly with 100 Mesh Screen	

15-743 MANIFOLD VALVE DRAWING

- 15-817 O-ring for #50 Series Clamp
- 15-818 O-ring for #75 Series Clamp

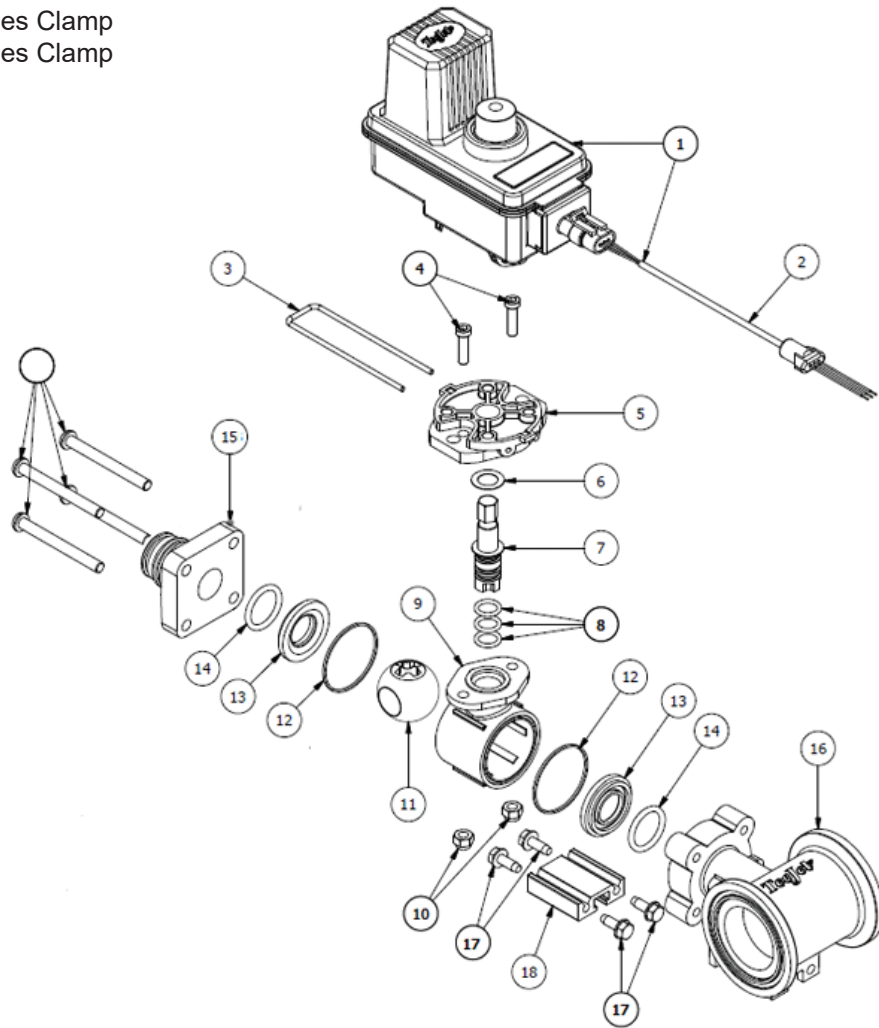

REF#	PART#	DESCRIPTION	QUANTITY
1	15-552-23	Motor	
2	15-878	Metri-Pack Cable (comes with motor)	1
3	15-552-24	Retaining Clip	1
4	15-552-25	Socket Head Cap Screw, Stainless Steel	2
5	15-552-26	Motor Adapter, Polypropylene	1
6*	15-517-11	Thrust Washer, Teflon	1
7	15-552-27	Stem, Stainless Steel	1
8*	15-552-05	O-ring, Viton	3
9	15-517-16	Body, Nylon	1
10		Lock Nut, Stainless Steel	2
11	15-743-04	Ball, Polypropylene	1
12*	15-552-13	Gasket, Viton	2
13*	15-517-19	Seal, Teflon	2
14*	15-517-20	O-ring, Viton	2
15	15-743-01	End Cap	1
16	15-743-02	75 Series Tee Body	1
17	15-743-06	Screw, SS	4
18	15-743-03	Mounting Rail Aluminum	1

- * 15-552-10 Spare Parts Kit (includes all * items)
- 15-743-05 Single Valve (shown)

14-673 2-WAY SHUT-OFF VALVE

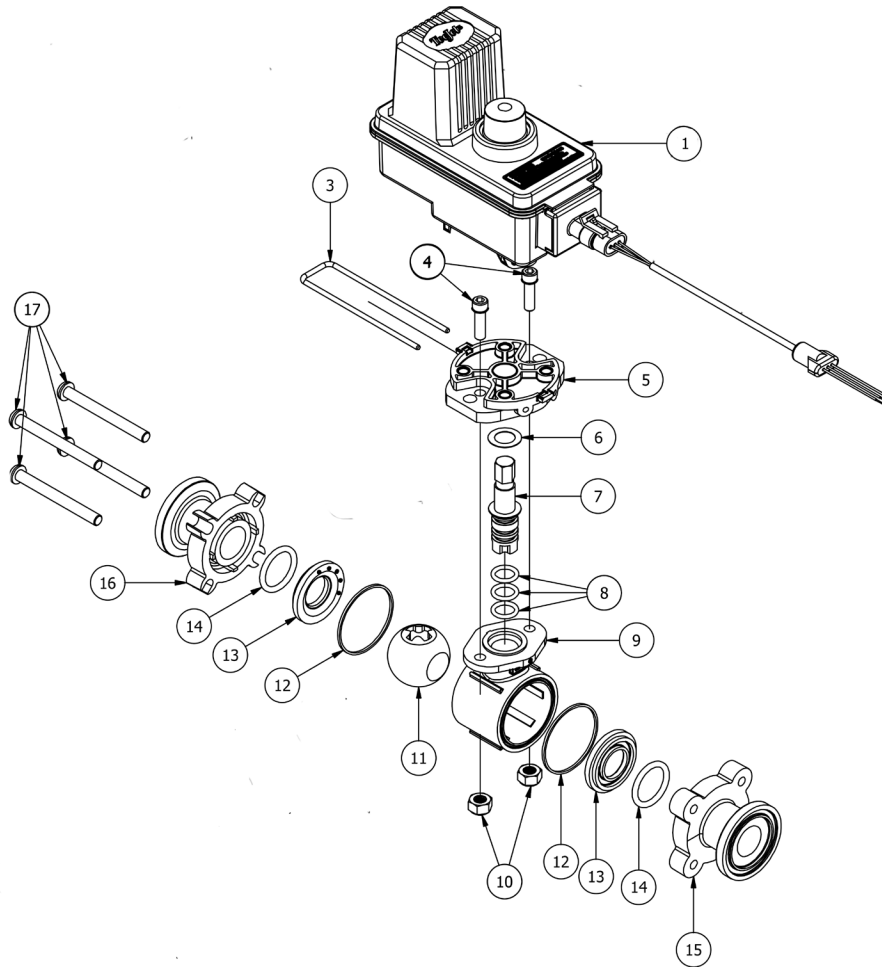

REF#	PART#	DESCRIPTION	QUANTITY
1	15-552-23	Motor	1
3	15-552-24	Retaining Clip	1
4		Socket Head Cap Screw, Stainless Steel	2
5	15-552-26	Motor Adapter, Polypropylene	1
6*	15-517-11	Thrust Washer, Teflon	1
7	15-552-27	Stem, Stainless Steel	1
8*	15-552-05	O-ring, Viton	3
9	15-517-16	Body, Nylon	1
10		Nylon Lock Nut, Stainless Steel	2
11	15-743-04	Ball, Polypropylene	1
12*	15-552-13	Gasket, Viton	2
13*	15-517-19	Seal, Teflon	2
14*	15-517-20	O-ring, Viton	2
15		#50 End Cap	1
16		#50 Flange End Cap	1
17		SS Hex Bolt, 1/4 - 20 x 2 3/4	4
*	15-552-10	Spare Parts Kit	
	14-673	Complete 2-way Shut-off Valve	

20-817 REGULATOR VALVE DRAWING

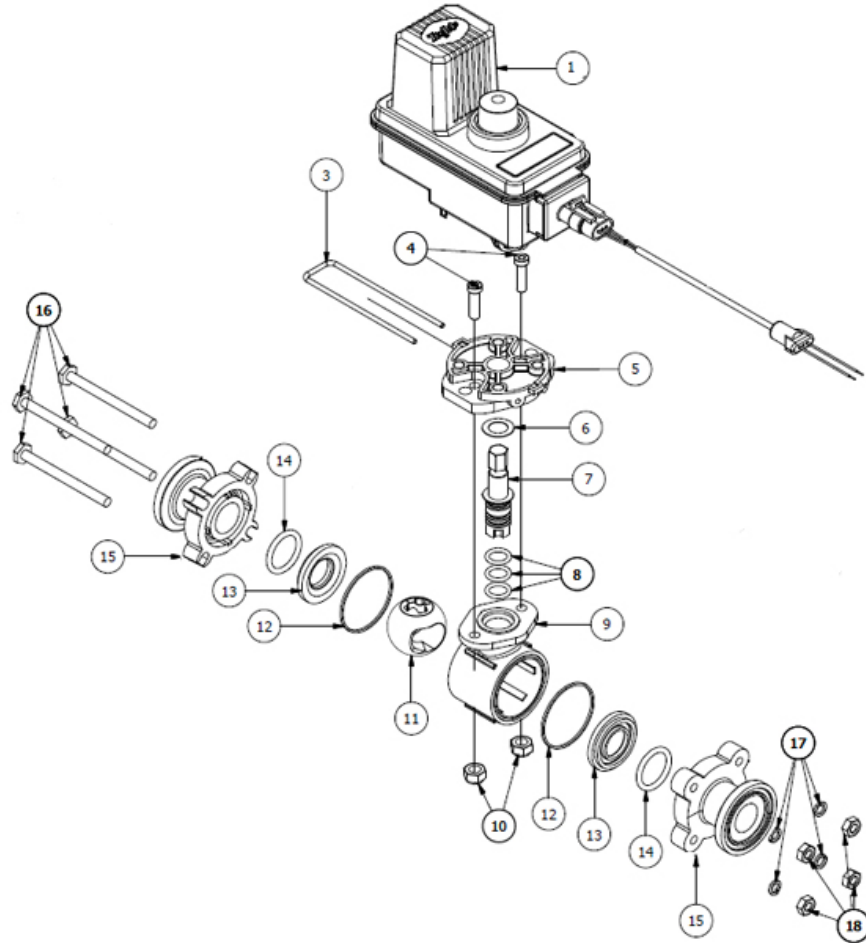

REF#	PART#	DESCRIPTION	QUANTITY
1	20-817-01	Motor	1
3	15-552-24	Retaining Clip	1
4		Socket Head Cap Screw, Stainless Steel	2
5	15-552-26	Motor Adapter, Polypropylene	1
6*	15-517-11	Thrust Washer, Teflon	1
7	15-552-27	Stem, Stainless Steel	1
8*	15-552-05	O-ring, Viton	3
9	15-517-16	Body, Nylon	1
10		Nylon Lock Nut, Stainless Steel	2
11	20-685-02	Ball, Polypropylene	1
12*	15-552-13	Gasket, Viton	2
13*	15-517-19	Seal, Teflon	2
14*	15-517-20	O-ring, Viton	2
15	15-743-01	End Cap	1
16		SS Hex Bolt, 1/4 - 20 x 3	4
17		SS Lock Washer, 1/4	4
18	15-517-23	SS Nut, 1/4 - 20	4
*	15-552-10	Spare Parts Kit	
	20-817	Complete Regulator Valve	

20-785 REGULATOR VALVE

15-817 O-ring for #50 Series Clamp

15-818 O-ring for #75 Series Clamp

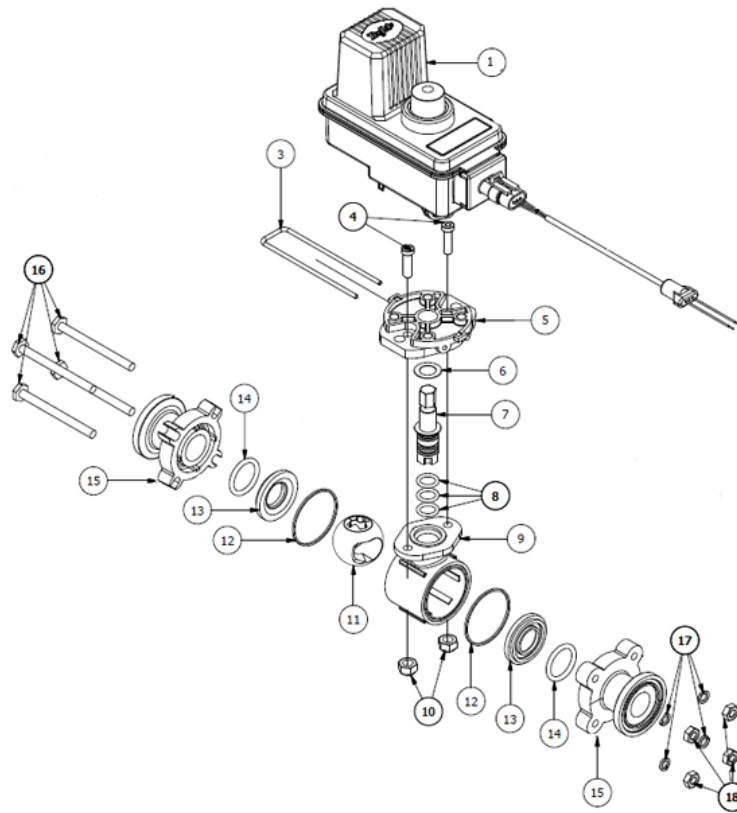

REF#	PART#	DESCRIPTION	QUANTITY
1	20-785-01	Motor, 6RPM	1
3	15-552-24	Retaining Clip	1
4		Socket Head Cap Screw, Stainless Steel	2
5	15-552-26	Motor Adapter, Polypropylene	1
6*	15-517-11	Thrust Washer, Teflon	1
7	15-552-27	Stem, Stainless Steel	1
8*	15-552-05	O-ring, Viton	3
9	15-517-16	Body, Nylon	1
10		Nylon Lock Nut, Stainless Steel	2
11	20-685-02	Ball, Polypropylene	1
12*	15-552-13	Gasket, Viton	2
13*	15-517-19	Seal, Teflon	2
14*	15-517-20	O-ring, Viton	2
15	15-743-01	End Cap	1
16		SS Hex Bolt, 1/4 - 20 x 3	4
17		SS Lock Washer, 1/4	4
18	15-517-23	SS Nut, 1/4 - 20	4
*	15-552-10	Spare Parts Kit	
	20-785	Complete Regulator Valve	

2 HINGE ASSEMBLIES PER BOOM

*17-632-K Boom Hinge Complete

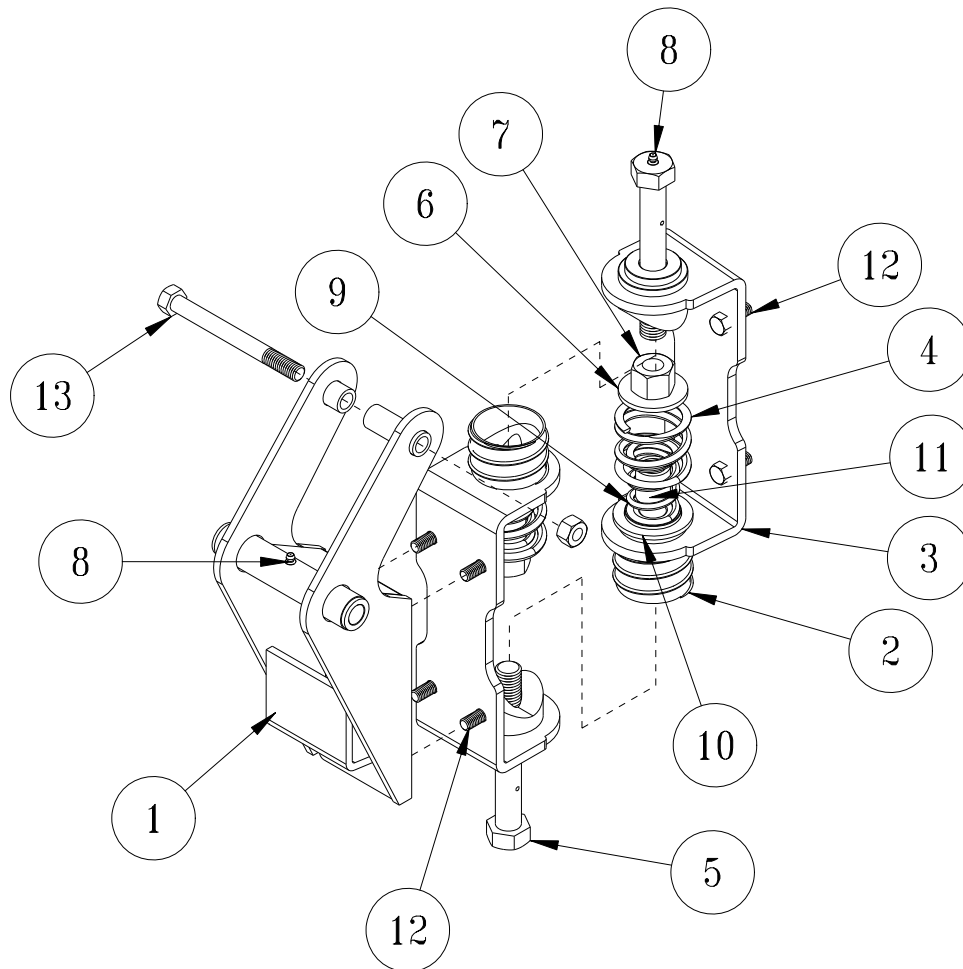

REF#	PART#	DESCRIPTION	QUANTITY
1	30-185	Arm Pivot Hinge (part of boom)	1
	HG-14-28-180	Grease Zerk (part of boom)	1
2*	9026-2	Rubber Duct Hose, 2"	2
3*	17-527	Boom Hinge	1
4*	17-539	Compression Spring	2
5*	17-540	Tapped Bolt	2
6*	HW-34	Flat Washer, $\frac{3}{4}$	2
7*	HNCL-34-10	Center Lock Nut, $\frac{3}{4}$ - 10	2
8*	HG-14-28-180	Grease Zerk	2
9*	17-591	Compression Spring	2
10*	17-599	Spring Shim	2
11*	17-594	Spring Sleeve	2
12*	HB-38-16-100	Hex Bolt, $\frac{3}{8}$ - 16 x 1	8
	HNFL-38-16	Flange Lock Nut, $\frac{3}{8}$ - 16	8
13	HB-12-13-500	Hex Bolt, $\frac{1}{2}$ - 13 x 5	1
	HNTL-12-13	Lock Nut, $\frac{1}{2}$ - 13	1

17-585 18' BOOM DRAWING

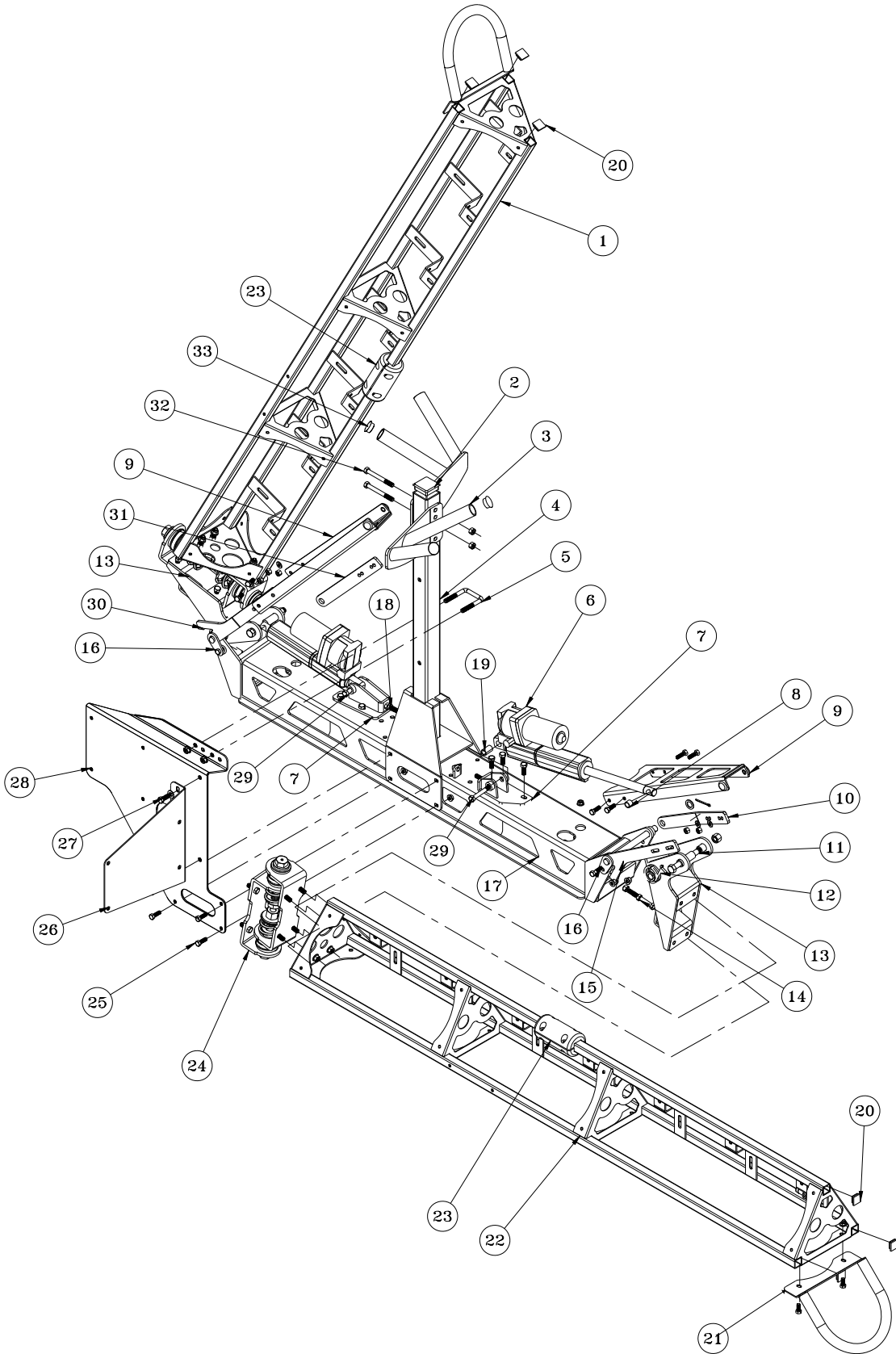

Accessories

17-585 18' BOOM PARTS LIST

REF#	PART#	DESCRIPTION	QUANTITY
1	17-652	Left Boom Arm	1
2	18-297	Cap Plug	1
3	17-617	Boom Nest	2
4	17-578	Boom Nest Post	1
5	17-537	Square U-Hex Bolt	1
6	30-214	KYB Electric/ Hydraulic Actuator (includes * items)	2
	30-187-01	Spherical Plain Bearing	
7	30-184	Ram Mount	2
	HN-38-16	Hex Nut, $\frac{3}{8}$ - 16 (for adjustment Hex Bolts)	4
	HB-38-16-100	Hex Bolt, $\frac{3}{8}$ - 16 x 1	6
	HW-38	Flat Washer, $\frac{3}{8}$	6
	HNFL-38-16	Flange Whiz-loc Nut, $\frac{3}{8}$ -16	6
8*	18-036	$\frac{1}{2}$ " Bushing (part of 30-214)	2
9	32-564	Boom Lock	2
	HB-516-18-100	Hex Bolt, $\frac{5}{16}$ - 18 x 1	8
	HW-516	Flat Washer, $\frac{5}{16}$	4
	HNTL-516-18	Nylon Lock Nut, $\frac{5}{16}$ -18	8
	42-116	Rubber Insert	4
	8803-2.75	Trim Lace, 2.75"	2
10	17-588	Lock Hinge, RH	1
11	HB-12-13-500	Hex Bolt, $\frac{1}{2}$ - 13 x 5	2
	HNTL-12-13	Nylon Lock Nut, $\frac{1}{2}$ - 13	2
12	17-597	Torsion Spring, RH	1
13	30-185	Arm Pivot Hinge	2
	HG-14-28-180	Grease Fitting, $\frac{1}{4}$ - 28 x 180°	2
	76-128	Bushing (part of 30-185)	4
14	HB-38-16-175	Hex Bolt, $\frac{3}{8}$ - 16 x $1\frac{3}{4}$	2
	HNFL-38-16	Flange Whiz-loc Nut, $\frac{3}{8}$ - 16	4
15	17-589	Limit Hinge, RH	1
16	17-596	Hinge Pin w/ Spacer	2
	HP-18-100	Cotter Pin $\frac{1}{8}$ x 1	2
	HB-516-18-100	Hex Bolt, $\frac{5}{16}$ - 18 x 1	2
	HNFL-516-18	Flange Whiz-loc Nut, $\frac{5}{16}$ -18	2
17	17-650	Boom Center	1
18	HB-38-16-100	Hex Bolt, $\frac{3}{8}$ - 16 x 1	2
	HNFL-38-16	Flange Whiz-loc Nut, $\frac{3}{8}$ - 16	4
19*	18-234	1" Bushing (part of 30-214)	2
20	30-258	Ribbed 1" Plug	10
21	17-541	Boom End Guard	2
	HBFL-516-18-075	Hex Bolt, $\frac{5}{16}$ - 18 x $\frac{3}{4}$	4
	HNFL-516-18	Flange Whiz-loc Nut, $\frac{5}{16}$ - 18	4
22	17-653	Right Boom Arm	1
23	17-573	Guide Block Set	2
	HB-14-20-125	Hex Bolt, $\frac{1}{4}$ - 20 x $1\frac{1}{4}$	8
	HNTL-14-20	Nylon Lock Nut, $\frac{1}{4}$ - 20	8
24	17-632	Boom Hinge Complete	2
	HB-38-16-100	Hex Bolt, $\frac{3}{8}$ - 16 x 1	16
	HNFL-38-16	Flange Whiz-loc Nut, $\frac{3}{8}$ - 16	16
25	HB-516-18-100	Hex Bolt, $\frac{5}{16}$ - 18 x 1	8
	HW-516	Flat Washer, $\frac{5}{16}$	8
	HNFL-516-18	Flange Whiz-loc Nut, $\frac{5}{16}$ - 18	8

(Continue on next page)

17-585 18' BOOM DRAWING

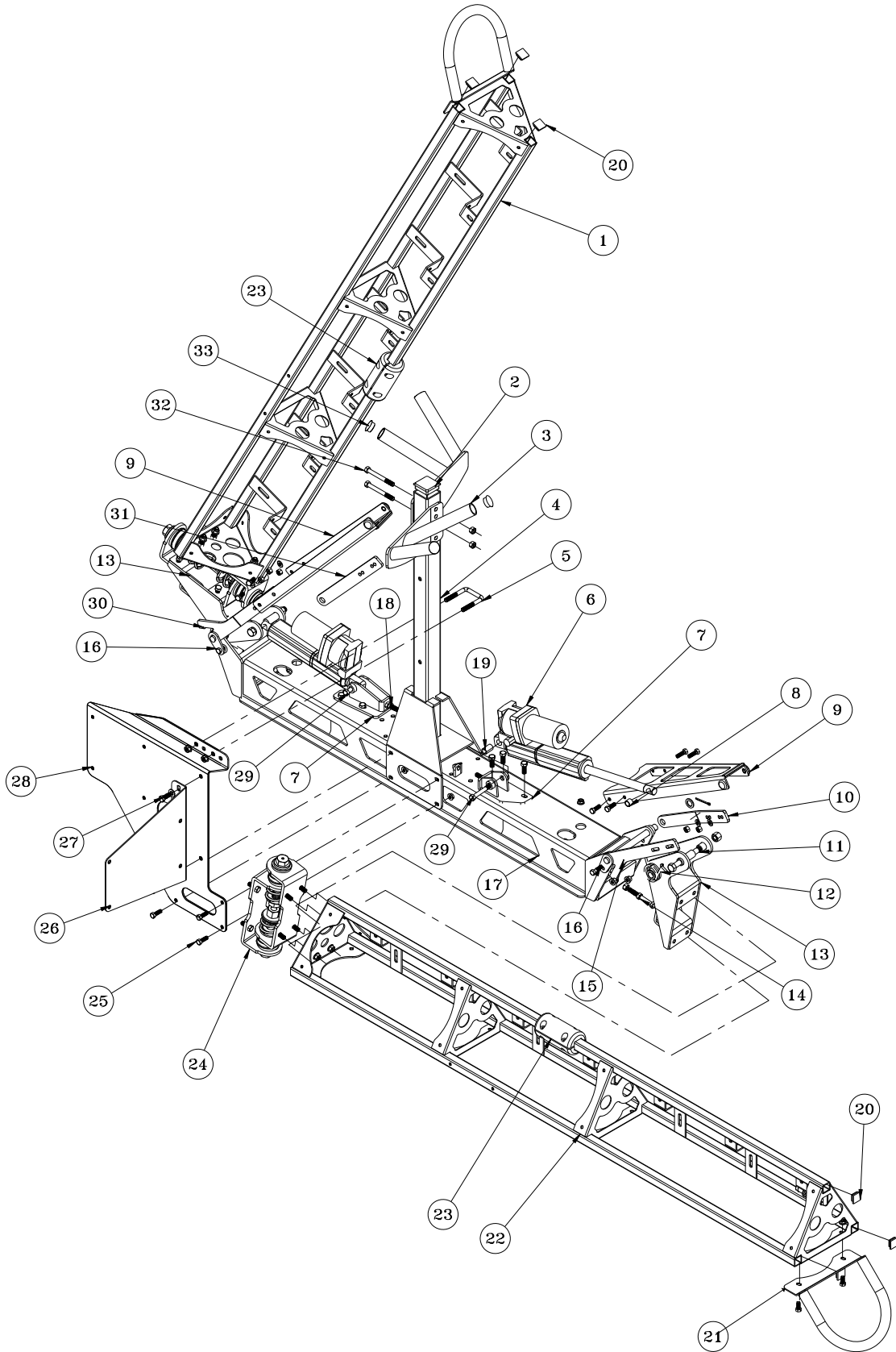

Accessories

17-585 18' BOOM PARTS LIST

REF#	PART#	DESCRIPTION	QUANTITY
26	17-636	Fresh Water Tank Mount	1
27	HB-38-16-100	Hex Bolt, $\frac{3}{8}$ - 16 x 1	2
	HNFL-38-16	Flange Whiz-loc Nut, $\frac{3}{8}$ - 16	2
	HW-38	Flat Washer, $\frac{3}{8}$	2
28	17-660	Clean Load Mount	1
	8803-13	Black Trim x 13"	1
29	HB-12-13-300	Hex Bolt, $\frac{1}{2}$ - 13 x 3	2
	HNTL-12-13	Nylon Lock Nut, $\frac{1}{2}$ - 13	2
30	17-593	Limit Hinge, LH	1
	17-598	Torsion Spring, LH	1
31	17-592	Lock Hinge, LH	1
32	HB-38-16-300	Hex Bolt, $\frac{3}{8}$ - 16 x 3	2
	HNTL-38-16	Nylon Lock Nut, $\frac{3}{8}$ - 16	2
33	17-619	Tube Cap	4

BOOM MOUNT TO TRUCK

REF#	PART#	DESCRIPTION	QUANTITY
A		Center Boom Mount	1
D	HB-38-16-125	Bolt, $\frac{3}{8}$ - 16 x $1\frac{1}{4}$	12
	HNFL-38-16	Flange Lock Nut, $\frac{3}{8}$ -16	12
	HW-38	Flat Washer, $\frac{3}{8}$	12
	HW-516	Flat Washer, $\frac{5}{16}$	12

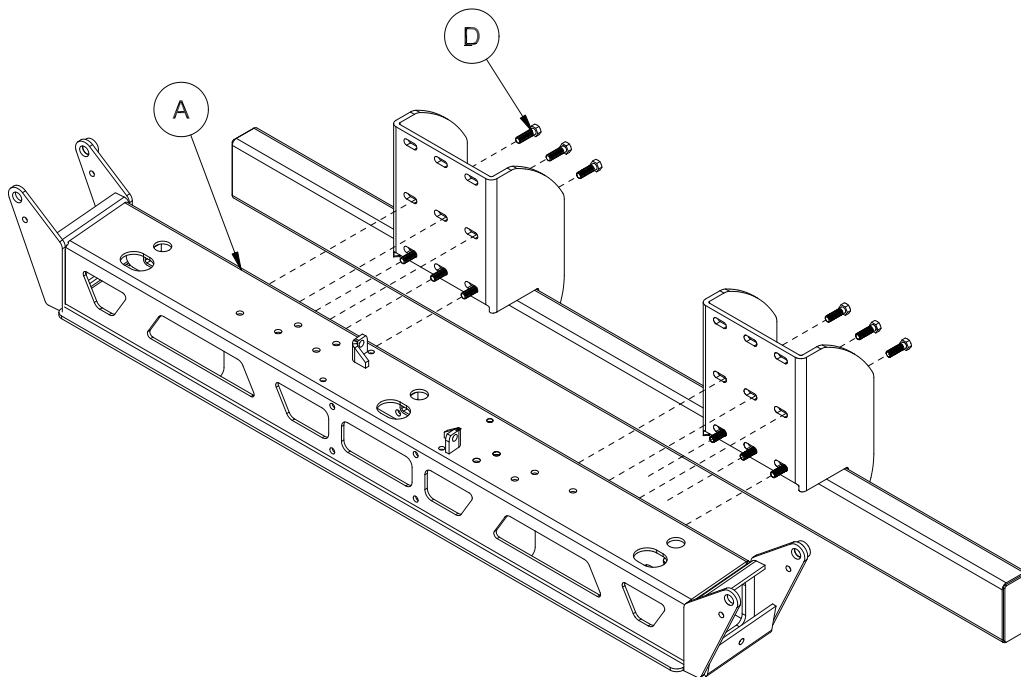

17-585 18' BOOM 1102/1104 PLUMBING

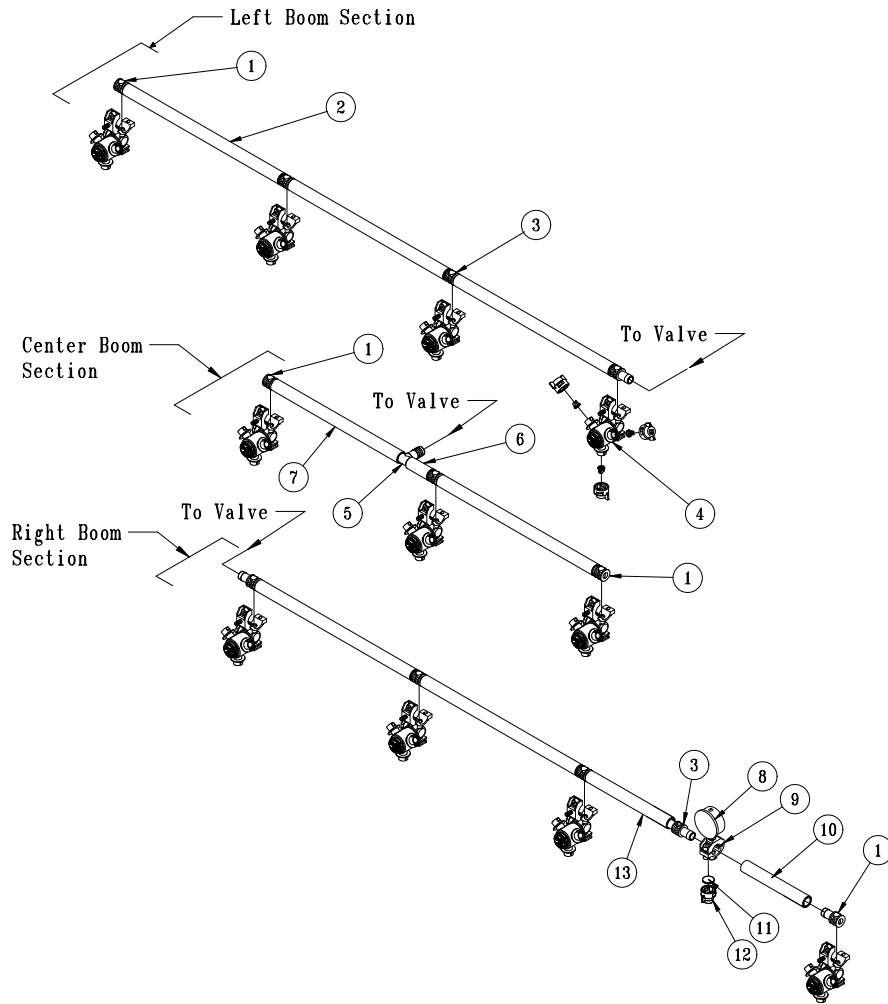

REF#	PART#	DESCRIPTION	QUANTITY
1	18-417	Single Barb	4
2	9032-19	Black Hose $\frac{3}{4}$ " x 19"	6
	18-040	Hose Clamp	12
3	18-416	Double Barb	8
4	33-563	Nozzle body (see nozzle drawing)	11
5	18-415	$\frac{3}{4}$ " Hose Barb	1
6	9032-2.5	Black Hose $\frac{3}{4}$ " x 2 $\frac{1}{2}$ "	1
	18-040	Hose Clamp	2
7	9032-15.5	Black Hose $\frac{3}{4}$ " x 15 $\frac{1}{2}$ "	1
	18-040	Hose Clamp	2
8	16-281	Gauge	1
9	17-602	Nozzle Body	1
10	9032-5	Black Hose $\frac{3}{4}$ " x 5"	1
	18-040	Hose Clamp	2
11	16-800	Gasket	1
12	16-921	Cap	1
13	9032-13	Black Hose $\frac{3}{4}$ " x 13"	1
	18-040	Hose Clamp	2

17-585 18' BOOM 1108 PLUMBING

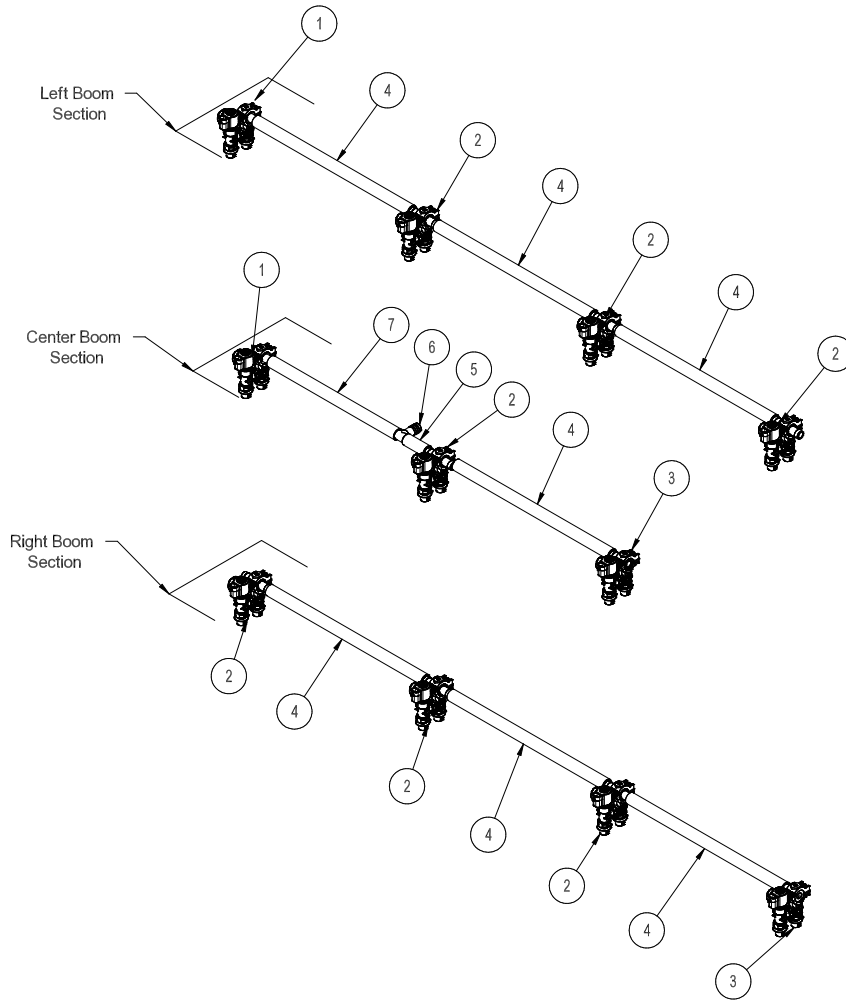

REF#	PART#	DESCRIPTION	QUANTITY
1	20-675	Single Hose Barb - Right Orientation	2
2	20-673	Single Hose Barb	7
3	20-674	Single Hose Barb - Left Orientation	2
4	9032-19	Black Hose $\frac{3}{4}$ " x 19"	7
	18-040	Hose Clamp	14
5	9032-2.5	Black Hose $\frac{3}{4}$ " x 2 $\frac{1}{2}$ "	1
	18-040	Hose Clamp	2
6	18-415	$\frac{3}{4}$ " Hose Barb	1
7	9032-15.5	Black Hose $\frac{3}{4}$ " x 15 $\frac{1}{2}$ "	1
	18-040	Hose Clamp	2

17-585 18' BOOM 1118-AG PLUMBING DRAWING

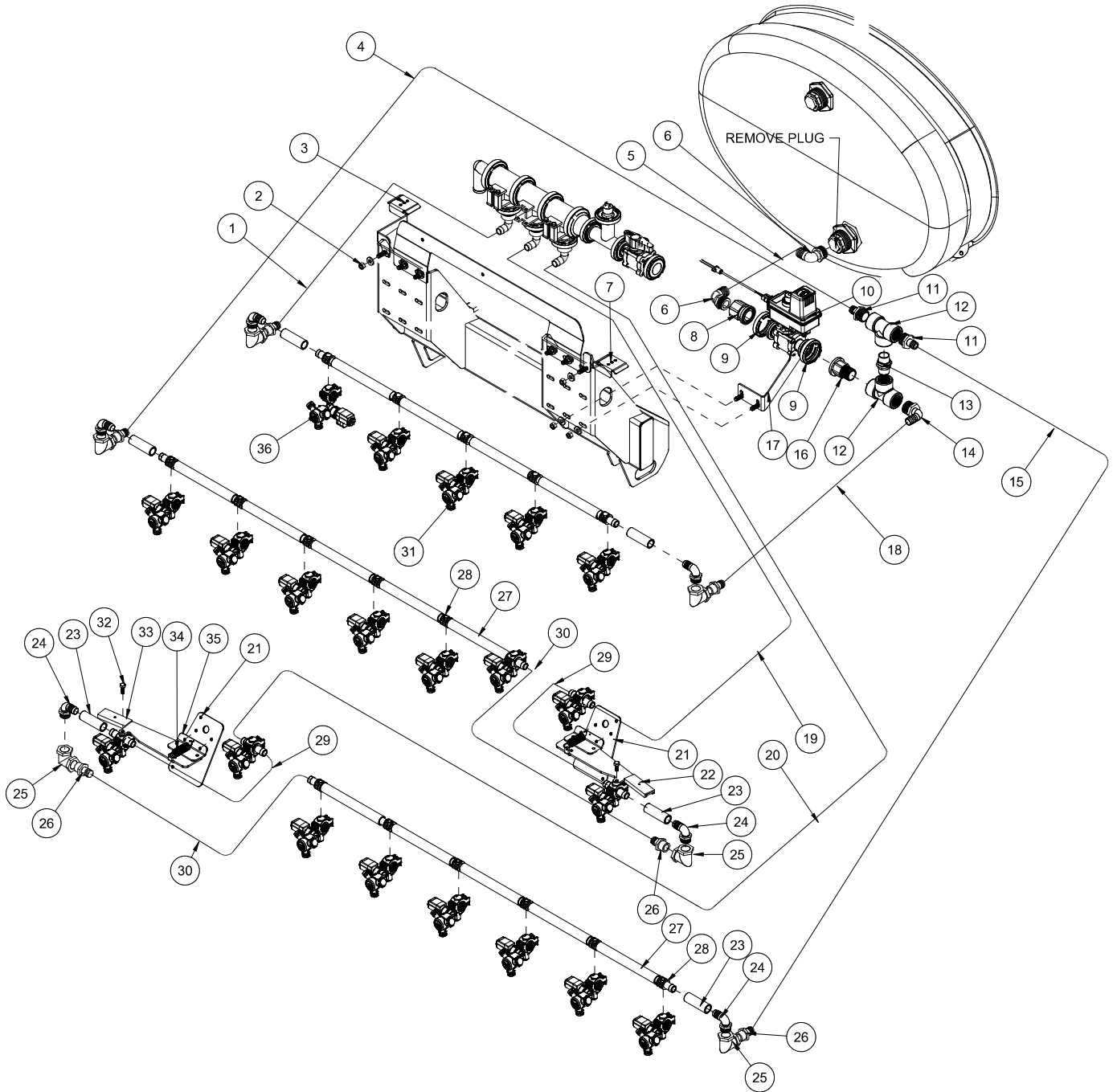

Accessories

REF#	PART#	DESCRIPTION	QUANTITY
1	9032	Black Hose, 3/4"	12"
	18-040	Hose Clamp	2
2	HB-38-16-125	Hex Bolt, 3/8 -16 x 1 1/4	4
	HW-38	Flat Washer, 3/8	4
	HNFL-38-16	Flange Whiz-loc Nut, 3/8-16	4
3	20-951	LH Hose Bracket	1
	22-131	Double Loop Cable Tie	1
4	9032	Black Hose, 3/4"	133"
	18-040	Hose Clamp	2

17-585 18' BOOM 1118-AG PLUMBING PARTS LIST

REF#	PART#	DESCRIPTION	QUANTITY
5	8896	1" Discharge Hose	3"
	18-222	Hose Clamp	2
6	16-164	Elbow, 1MPT x 1HP	2
7	20-953	RH Hose Bracket	1
	22-131	Double loop Cable Tie	1
8	15-735	#50 x 1" FPT	1
9	15-740	#50 Clamp	2
10	14-673	Shutoff Valve	1
11	20-834	Adapter, 1" MPT x 3/4 HB	2
12	18-515	Tee, 1" FTP	2
13	18-514	Black Close Nipple, 1"	1
14	16-174	Elbow, 1" MPT x 3/4 HB	1
15	9032	Black Hose 3/4"	89"
	18-040	Hose Clamp	2
16	15-987	Fitting, #50 x 1" MPT	1
17	20-955	Valve Mount Bracket	1
18	9032	Black Hose, 3/4"	5.5"
	18-040	Hose Clamp	2
19	9032	Black Hose, 3/4"	43.5"
	18-040	Hose Clamp	2
20	9032	Black Hose, 3/4"	48"
	18-040	Hose Clamp	2
21	17-559	Break-A-Way Mount	2
	HB-14-20-075	Hex Bolt, 1/4 - 20 x 3/4	4
	HW-14	Flat Washer, 1/4	4
	HNTL-14-20	Lock Nut, 1/4-20	4
22	17-562	LH Break-A-Way Arm	1
	8946-3.5	Plastic Wear Strip	1
	HRS-316-050	Rivet, 3/16 x 1/2	1
	HB-14-20-075	hex Bolt, 1/4-20 x 3/4	2
	HNFL-14-20	Flange Whiz-loc Nut, 1/4-20	2
23	9032-3	Black Hose, 3/4"	6
	18-040	Hose Clamp	12
24	16-153	Elbow, 3/4" MPT x 3/4" HP	6
25	16-151	Elbow, 3/4" FPT	6
26	16-154	Fitting, 3/4"	6
27	9032-8.5	Black Hose 3/4"	14
	18-040	Hose Clamp	28
28	18-416	Double Barb	21
29	9032-25	Black Hose 3/4"	2
	18-040	Hose Clamp	4
30	9032-24	Black Hose 3/4"	2
	18-040	Hose Clamp	4
31	20-946	LH Nozzle Body	20
32	HB-516-18-075	Hex Bolt, 5/16 - 18 x 1 1/4	21
	HNFL-516-18	Flange Whiz-loc Nut, 5/16-18	21
33	17-561	RH Break-A-Way Arm	1
	8946-3.5	Plastic Wear Strip	1
	HRS-316-050	Rivet, 3/16 x 1/2	1
	HB-14-20-075	hex Bolt, 1/4-20 x 3/4	2
	HNFL-14-20	Flange Whiz-loc Nut, 1/4-20	2
34	11-050	Spring	2
35	17-560	Hinge Mount	2
	HB-14-20-075	hex Bolt, 1/4-20 x 3/4	4
	HNFL-14-20	Flange Whiz-loc Nut, 1/4-20	4
36	20-954	RH Nozzle Body	1

17-601/15-835 15' BOOM DRAWING

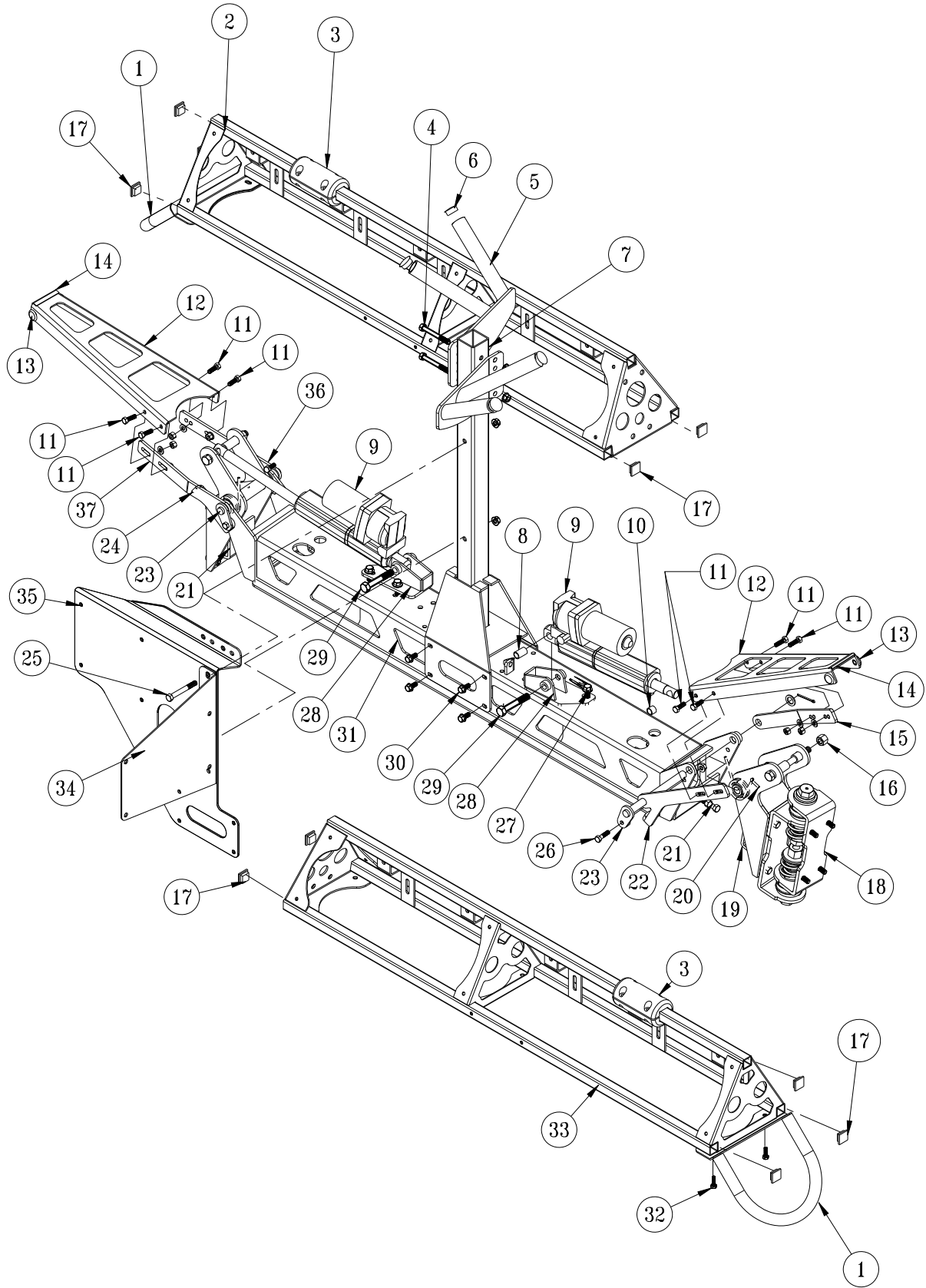

Accessories

17-601/15-835 15' BOOM PARTS LIST

REF#	PART#	DESCRIPTION	QUANTITY
1	17-541	Boom End Guard	2
2	17-551	Left Boom Arm	1
3	17-573	Guide Block Set	2
	HB-14-20-125	Hex Bolt, 1/4 -20 x 1 1/4	8
	HNTL-14-20	Lock Nut, 1/4 - 20	8
4	HB-38-16-300	Hex Bolt, 3/8 - 16 x 3	2
	HNTL-38-16	Lock Nut, 3/8 - 16	2
5	17-617	V-Boom Nest	2
6	17-619	Push-In Rounds	4
7	17-578	Boom Nest Post	1
	18-297	Cap Plug	1
8	18-036	1" Bushing (part of 30-214)	2
9	30-214	10" Electric/Hydraulic Actuator	2
	30-187-01	Spherical Plain Bearing	
10	18-234	1/2" Bushing (part of 30-214)	2
11	HB-516-18-100	Hex Bolt, 5/16 -16 x 1	8
	HW-516	Flat Washer, 5/16	4
	HNTL-516-18	Lock Nut, 5/16 - 18	8
12	32-564	Boom Lock	2
13	42-116	Rubber Insert	4
14	8803-2.75	Trim Lace, 2 3/4	2
15	17-588	Lock Hinge, RH	1
16	HB-12-13-500	Hex Bolt, 1/2 - 13 x 5	2
	HNTL-12-13	Lock Nut, 1/2 -13	2
17	30-258	1" 10-14ga Ribbed Plug	10
18	17-632	Boom Hinge Complete	2
	HB-38-16-100	Hex Bolt, 3/8 - 16 x 1	16
	HNFL-38-16	Flange Whiz-loc Nut, 3/8 - 16	16
19	30-185	Arm Pivot Hinge	2
	HG-14-28-180	Grease Fitting, 1/4 - 28 x 180°	2
	76-128	Bushing (part of 30-185)	4
20	17-597	Torsion Spring, RH	1
21	HB-38-16-175	Hex Bolt, 3/8 - 16 x 1 3/4	2
	HNFL-38-16	Flange Whiz-loc Nut, 3/8 - 16	4
22	17-589	Limit Hinge, RH	1
23	17-596	Hinge Pin w/Spacer	2
	HP-18-100	Cotter Pin, 1/8 x 1	2
24	17-598	Torsion Spring, LH	1
25	HB-38-16-100	Hex Bolt, 3/8 - 16 x 1	2
	HW-38	Flat Washer, 3/8	2
	HNFL-38-16	Flange Whiz-loc Nut, 3/8 - 16	2
26	HB-516-18-100	Hex Bolt, 5/16 -16 x 1	2
	HNFL-516-18	Flange Whiz-loc Nut, 5/16 - 18	2
27	HB-38-16-100	Hex Bolt, 3/8 - 16 x 1	6
	HW-38	Flat Washer, 3/8	6
	HNFL-38-16	Flange Whiz-loc Nut, 3/8 -16	6
28	30-184	Ram Mount	2
	HN-38-16	Nut, 3/8 - 16 (on adjustment nuts)	4
29	HB-12-13-300	Hex Bolt, 1/2 - 13 x 3	2
	HNTL-12-13	Lock Nut, 1/2 - 13	2
30	HB-516-18-100	Hex Bolt, 5/16 - 18 x 1	8
	HW-516	Flat Washer, 5/16	8
	HNFL-516-18	Flange Whiz-loc Nut, 5/16 - 18	8

(Continued on next page)

17-601/15-835 15' BOOM DRAWING

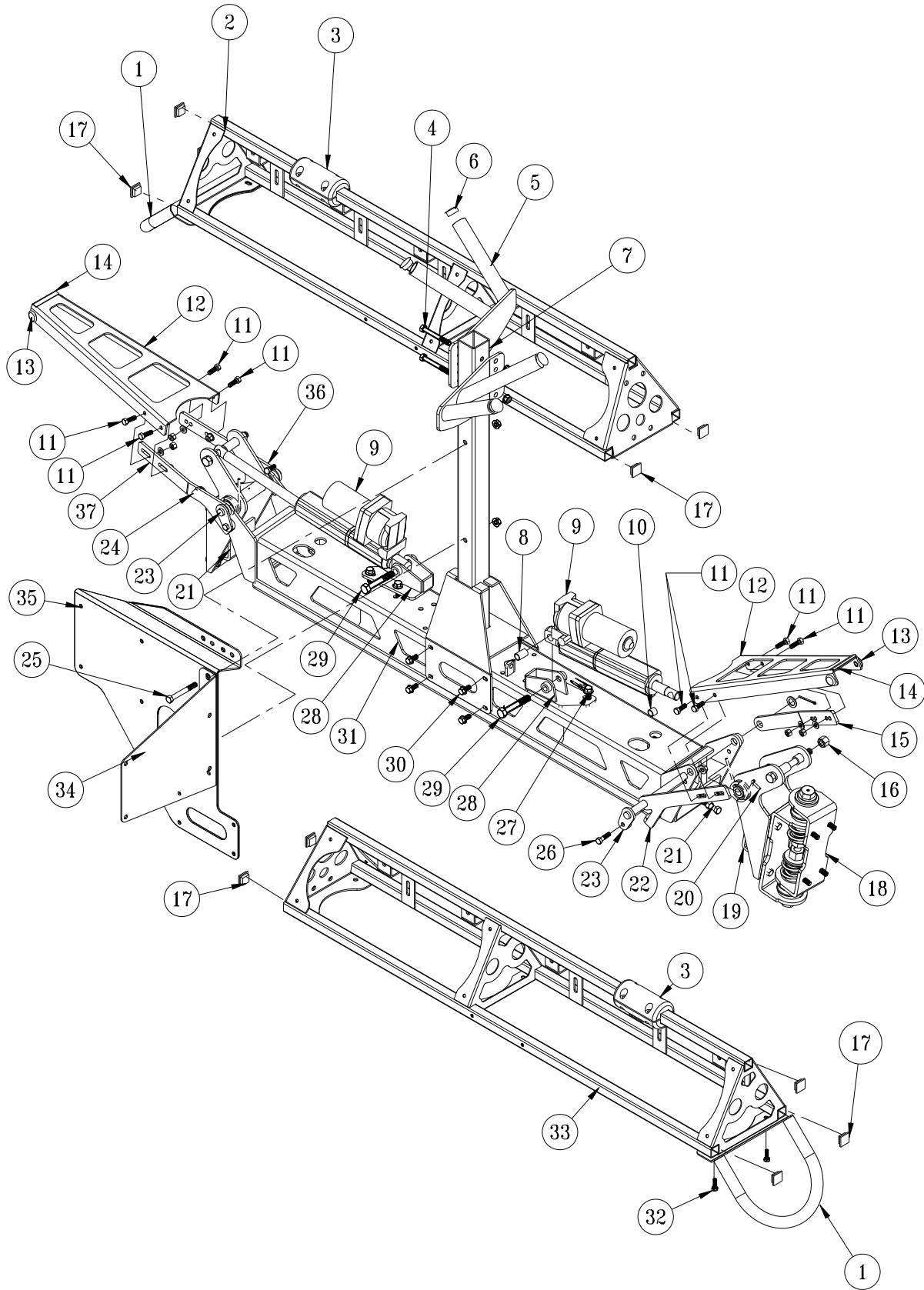

Accessories

17-601/15-835 15' BOOM PARTS LIST

REF#	PART#	DESCRIPTION	QUANTITY
31	17-528	Boom Center	1
	25-334	Decal, Serial Tag	1
32	HBFL-516-18-075	Hex Bolt, $\frac{5}{16}$ - 18 x $\frac{3}{4}$	4
	HNFL-516-18	Flange Whiz-loc Nut, $\frac{5}{16}$ - 18	4
33	17-552	Right Boom Arm	1
34	17-636	Freshwater Mount	1
35	17-660	Clean Load Mount	1
	8803-13	Black Trim, 13"	
36	17-592	Lock Hinge, LH	1
37	17-593	Limit Hinge, LH	1
38	17-537	Square U-bolt	1
	HNCL-34-10	Center Lock Nut, $\frac{3}{4}$ -10	4

BOOM MOUNT TO TRUCK

REF#	PART#	DESCRIPTION	QUANTITY
A		Center Boom Mount	1
D	HB-38-16-125	Bolt, $\frac{3}{8}$ - 16 x $1\frac{1}{4}$	12
	HNFL-38-16	Flange Lock Nut, $\frac{3}{8}$ -16	12
	HW-38	Flat Washer, $\frac{3}{8}$	12
	HW-516	Flat Washer, $\frac{5}{16}$	12

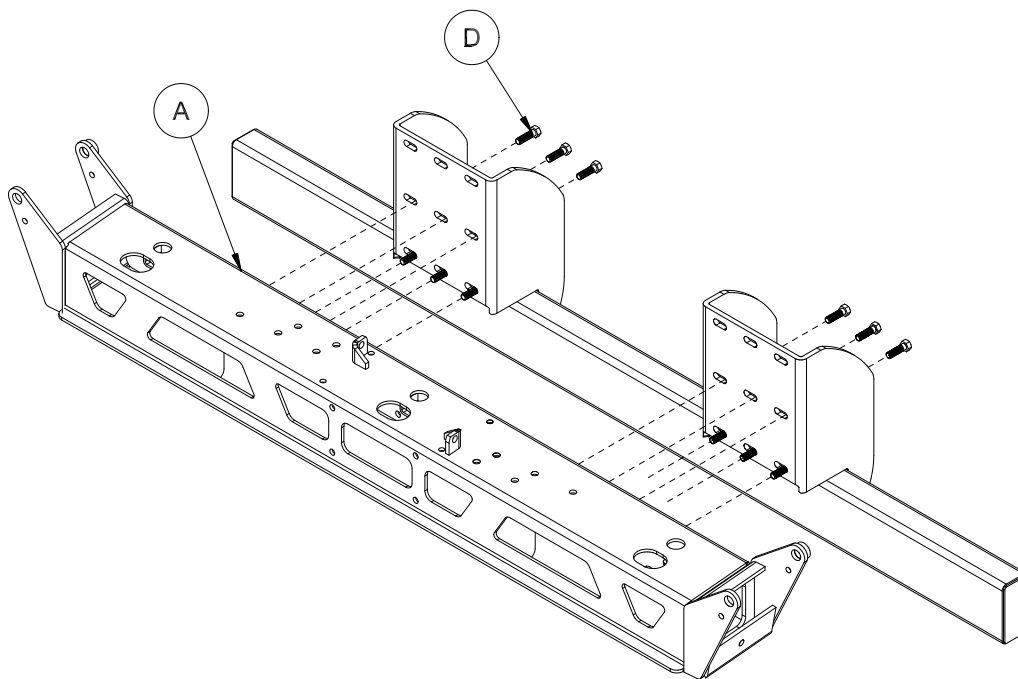

17-601 15' BOOM 1102/1104 PLUMBING

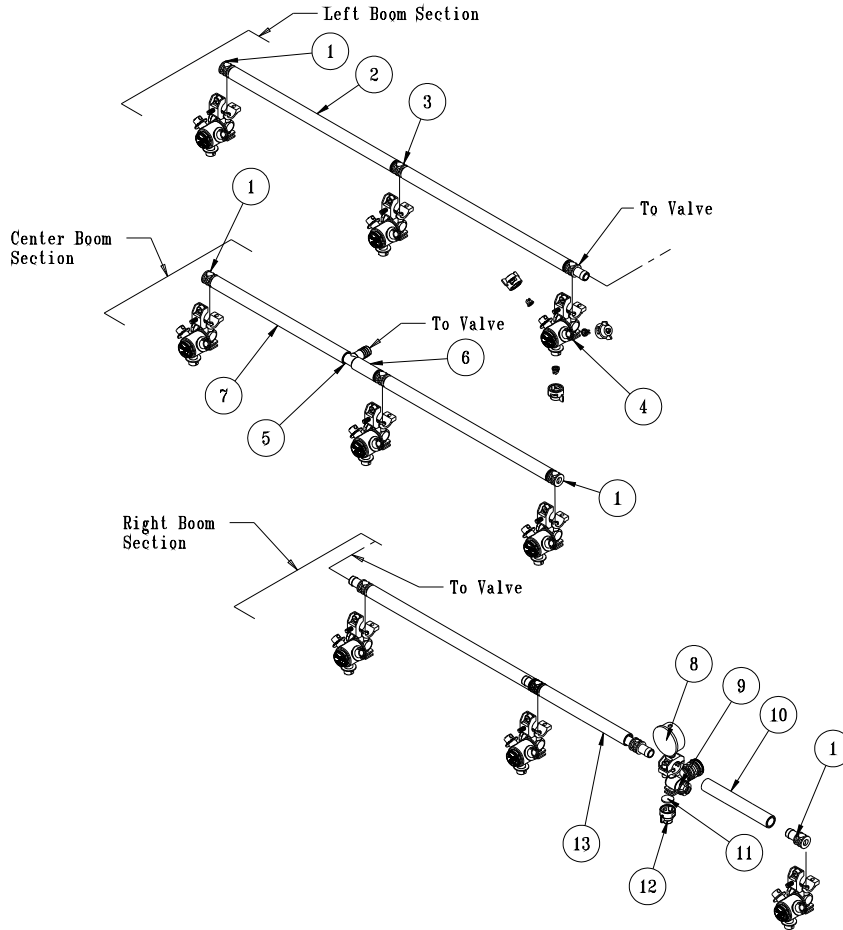

REF#	PART#	DESCRIPTION	QUANTITY
1	18-417	Single Barb	4
2	9032-19	Black Hose $\frac{3}{4}$ " x 19"	4
	18-040	Hose Clamp	8
3	18-416	Double Barb	6
4	33-563	Nozzle body (see nozzle drawing)	9
5	18-415	$\frac{3}{4}$ " Hose Barb	1
6	9032-2.5	Black Hose $\frac{3}{4}$ " x 2 $\frac{1}{2}$ "	1
	18-040	Hose Clamp	2
7	9032-15.5	Black Hose $\frac{3}{4}$ " x 15 $\frac{1}{2}$ "	1
	18-040	Hose Clamp	2
8	16-281	Gauge	1
9	17-602	Nozzle Body	1
10	9032-5	Black Hose $\frac{3}{4}$ " x 5"	1
	18-040	Hose Clamp	2
11	16-800	Gasket	1
12	16-921	Cap	1
13	9032-13	Black Hose $\frac{3}{4}$ " x 13"	1
	18-040	Hose Clamp	2

17-601 15' BOOM 1105 PLUMBING

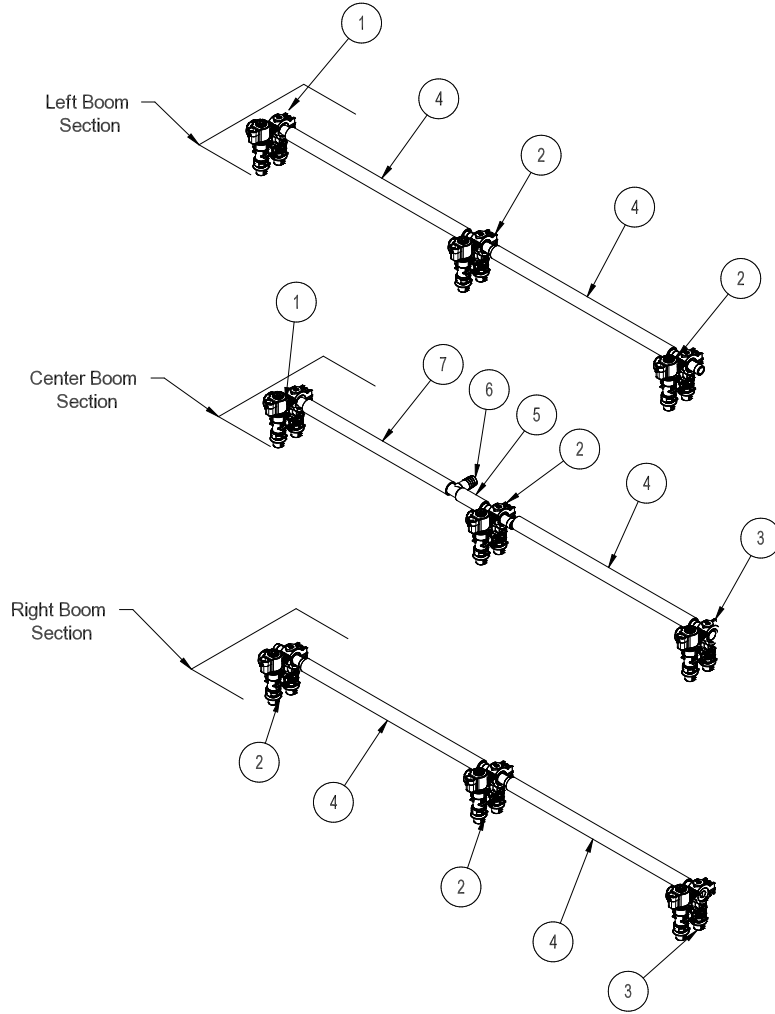

REF#	PART#	DESCRIPTION	QUANTITY
1	20-675	Single Hose Barb - Right Orientation	2
2	20-673	Single Hose Barb	5
3	20-674	Single Hose Barb - Left Orientation	2
4	9032-19	Black Hose $\frac{3}{4}$ " x 19"	5
	18-040	Hose Clamp	10
5	9032-2.5	Black Hose $\frac{3}{4}$ " x 2 $\frac{1}{2}$ "	1
	18-040	Hose Clamp	2
6	18-415	$\frac{3}{4}$ " Hose Barb	1
7	9032-15.5	Black Hose $\frac{3}{4}$ " x 15 $\frac{1}{2}$ "	1
	18-040	Hose Clamp	2

17-835 15' BOOM 1115-AG PLUMBING

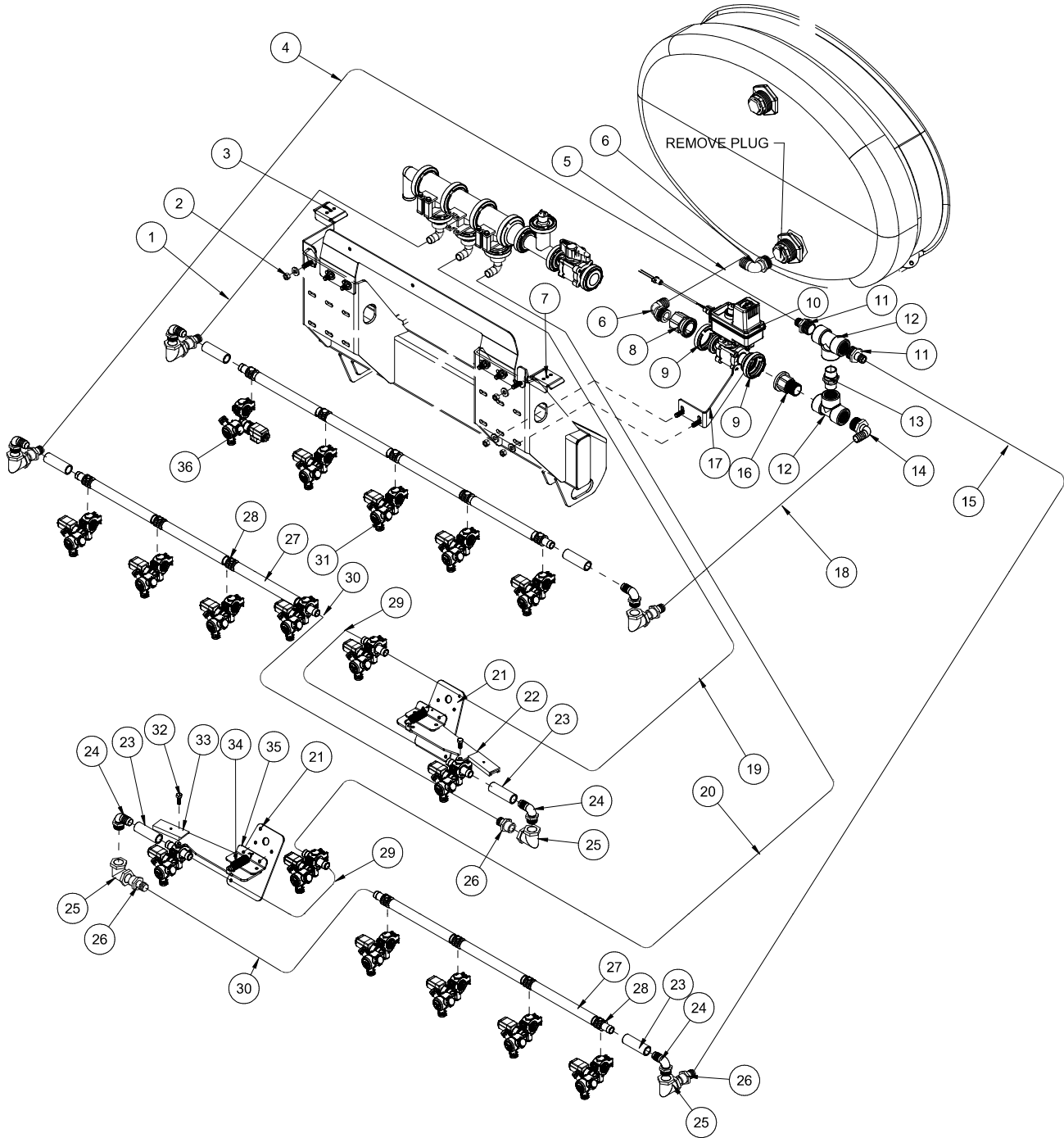

REF#	PART#	DESCRIPTION	QUANTITY
1	9032	Black Hose, 3/4"	12"
	18-040	Hose Clamp	2
2	HB-38-16-125	Hex Bolt, 3/8 -16 x 1 1/4	4
	HW-38	Flat Washer, 3/8	4
	HNFL-38-16	Flange Whiz-loc Nut, 3/8-16	4
3	20-951	LH Hose Bracket	1
	22-131	Double Loop Cable Tie	1
4	9032	Black Hose, 3/4"	116"
	18-040	Hose Clamp	2

17-835 15' BOOM 1115-AG PLUMBING PARTS LIST

REF#	PART#	DESCRIPTION	QUANTITY
5	8896	1" Discharge Hose	3"
	18-222	Hose Clamp	2
6	16-164	Elbow, 1MPT x 1HP	2
7	20-953	RH Hose Bracket	1
	22-131	Double Loop Cable Tie	1
8	15-735	#50 x 1FPT	1
9	15-740	#50 Clamp	2
10	14-673	Shutoff Valve	1
11	20-834	Adapter, 1" MPT x 3/4 HB	2
12	18-515	Tee, 1" FP	2
13	18-514	Black Close Nipple, 1"	1
14	16-174	Elbow, 1" MPT x 3/4 HB	1
15	9032	Black Hose, 3/4"	69"
	18-040	Hose Clamp	2
16	15-987	Fitting, #50 x 1" MPT	1
17	20-955	Valve Mount Bracket	1
18	9032	Black Hose, 3/4"	5.5"
	18-040	Hose Clamp	2
19	9032	Black Hose, 3/4"	43.5"
	18-040	Hose Clamp	2
20	9032	Black Hose, 3/4"	48"
	18-040	Hose Clamp	2
21	17-559	Break-A-Way Mount	2
	HB-14-20-075	Hex Bolt, 1/4 - 20 x 3/4	4
	HW-14	Flat Washer, 1/4	4
	HNTL-14-20	Lock Nut, 1/4-20	4
22	17-562	LH Break-A-Way Arm	1
	8946-3.5	Plastic Wear Strip	1
	HRS-316-050	Rivet, 3/16 x 1/2	1
	HB-14-20-075	hex Bolt, 1/4-20 x 3/4	2
	HNFL-14-20	Flange Whiz-loc Nut, 1/4-20	2
23	9032-3	Black Hose, 3/4"	6
	18-040	Hose Clamp	12
24	16-153	Elbow, 3/4 "MPT x 3/4" HP	6
25	16-151	Elbow, 3/4" FPT	6
26	16-154	Fitting, 3/4"	6
27	9032-8.5	Black Hose, 3/4"	10
	18-040	Hose Clamp	20
28	18-416	Double Barb	17
29	9032-25	Black Hose, 3/4"	2
	18-040	Hose Clamp	4
30	9032-24	Black Hose, 3/4"	2
	18-040	Hose Clamp	4
31	20-946	LH Nozzle Body	16
32	HB-516-18-075	Hex Bolt, 5/16 - 18 x 1 1/4	17
	HNFL-516-18	Flange Whiz-loc Nut, 5/16-18	17
33	17-561	RH Break-A-Way Arm	1
	8946-3.5	Plastic Wear Strip	1
	HRS-316-050	Rivet, 3/16 x 1/2	1
	HB-14-20-075	hex Bolt, 1/4-20 x 3/4	2
	HNFL-14-20	Flange Whiz-loc Nut, 1/4-20	2
34	11-050	Spring	2
35	17-560	Hinge Mount	2
	HB-14-20-075	hex Bolt, 1/4-20 x 3/4	2
	HNFL-14-20	Flange Whiz-loc Nut, 1/4-20	2
36	20-954	RH Nozzle Body	1

1105/1108 NOZZLE DRAWING

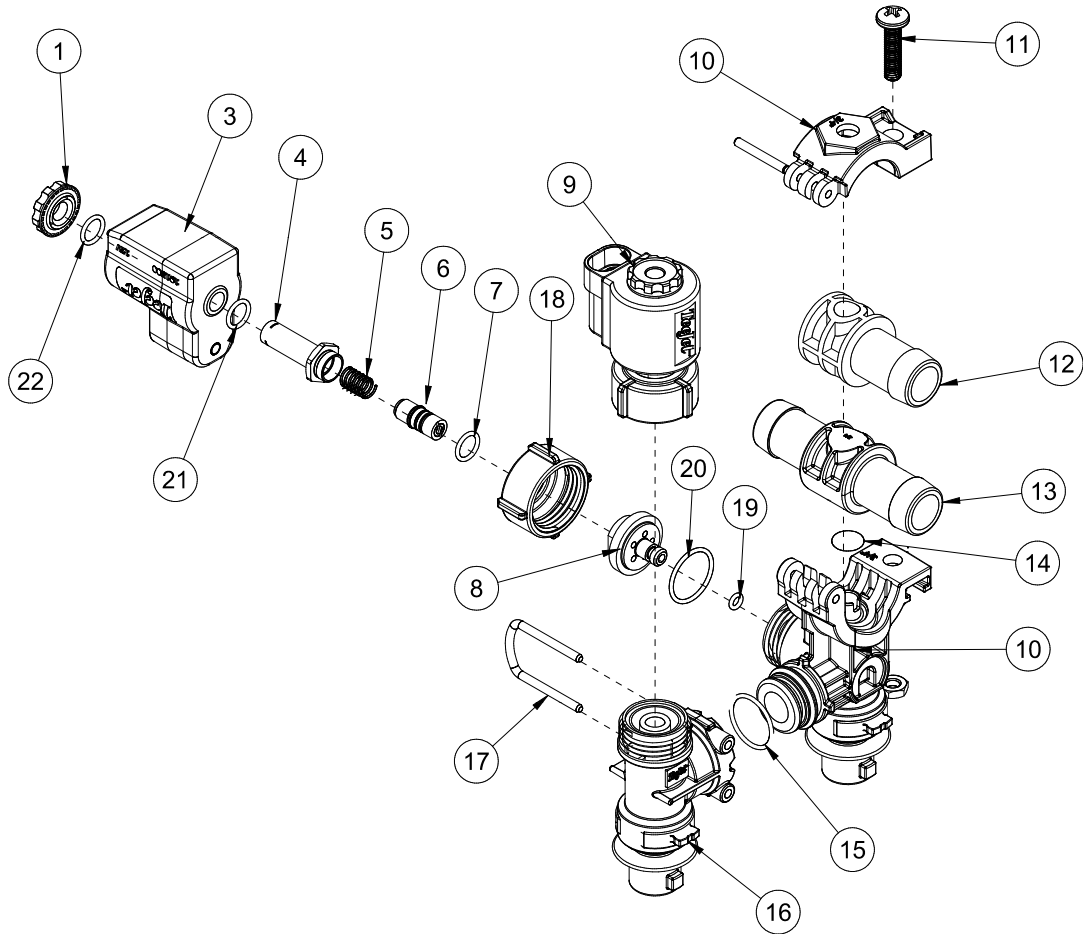

REF#	PART#	DESCRIPTION	QUANTITY
1†§		Nylon Black Nut	1
3§	20-674-04	12V Coil Assembly (includes § items)	1
4†		Tube Sub Assembly	1
5*†		302 Stainless Steel Spring	1
6*†		Viton O-ring	1
7*†		Plunger	1
8†		303 Stainless Steel Cap	1
9	20-674-01	E-Chemsaver Solenoid	1
10	20-673-04	3/4" Mount Assembly	1
11		Pan Head Screw	1
12	18-417	Single Barb (part of 20-674-P and 20-675-P)	1
13	18-416	Double Barb (part of 20-673-P)	1
14	16-920-03	O-ring	1
15	20-673-11	O-ring	1
16	20-673-05	End Body Sub-assembly	1
17	20-673-08	Retaining Clip	1
18		Locking Ring	1
19*†	20-673-07	Viton O-ring	1
20*†	20-673-06	Viton Gasket	1
21§		Oring, FKM	1
22§		Oring,FKM	1
*	20-674-02	Spare Parts Kit	
†	20-674-03	Field Repair Kit	

1105/1108 NOZZLE ASSEMBLY

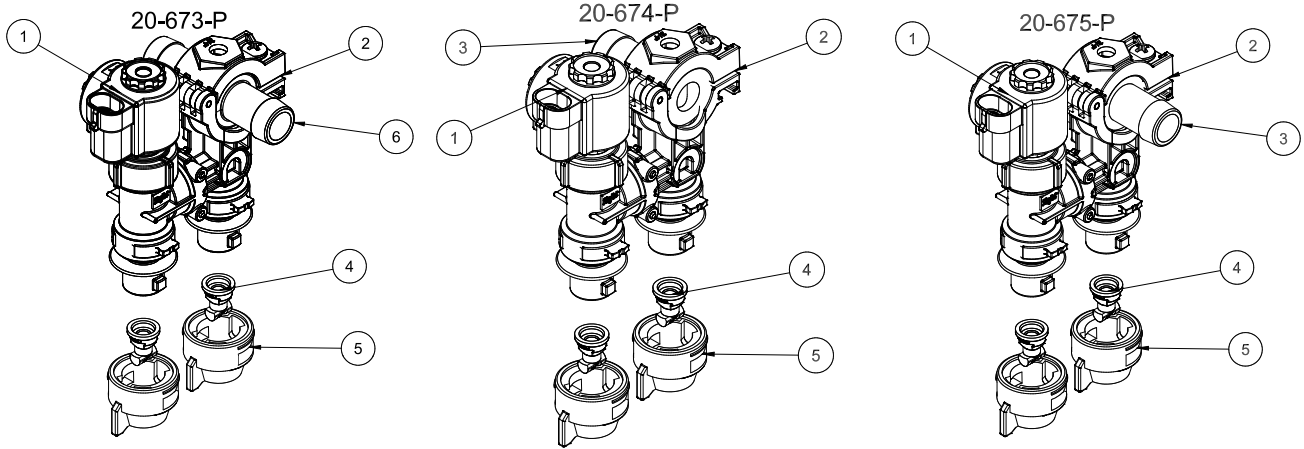

REF#	PART#	DESCRIPTION	QUANTITY
1*	20-673-02	E-Chemsaver®	1
2*	20-673-04	3/4" Bottom Mount Nozzle Body	1
3†	18-417	Single Barb	1
4	20-676	Turbo TeeJet Tip	2
5	20-677	QT White Cap and Washer	2
6‡	18-416	Double Hose Barb	1

Quantity is per nozzle body. For 15' booms multiply quantity by 9.
 Quantity is per nozzle body. For 18' booms multiply quantity by 11.

20-673	Double Hose Barb Nozzle (includes * and ‡ item)	8 or 9
20-674	Single Hose Barb Left Orientation (includes * and † item)	2
20-675	Single Hose Barb - Right Orientation (includes * and † item)	2

Nozzles are located 20" (51 cm) apart on the right, left, and center tubes. Nozzles are 20" high off ground.

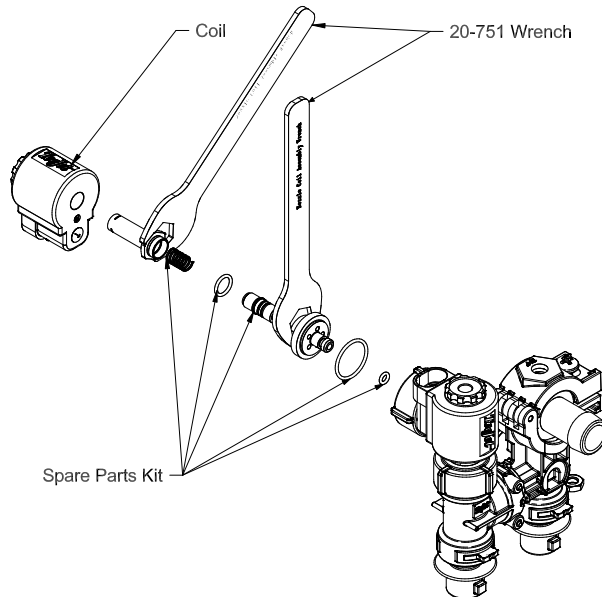

33-563 STANDARD NOZZLE DRAWING

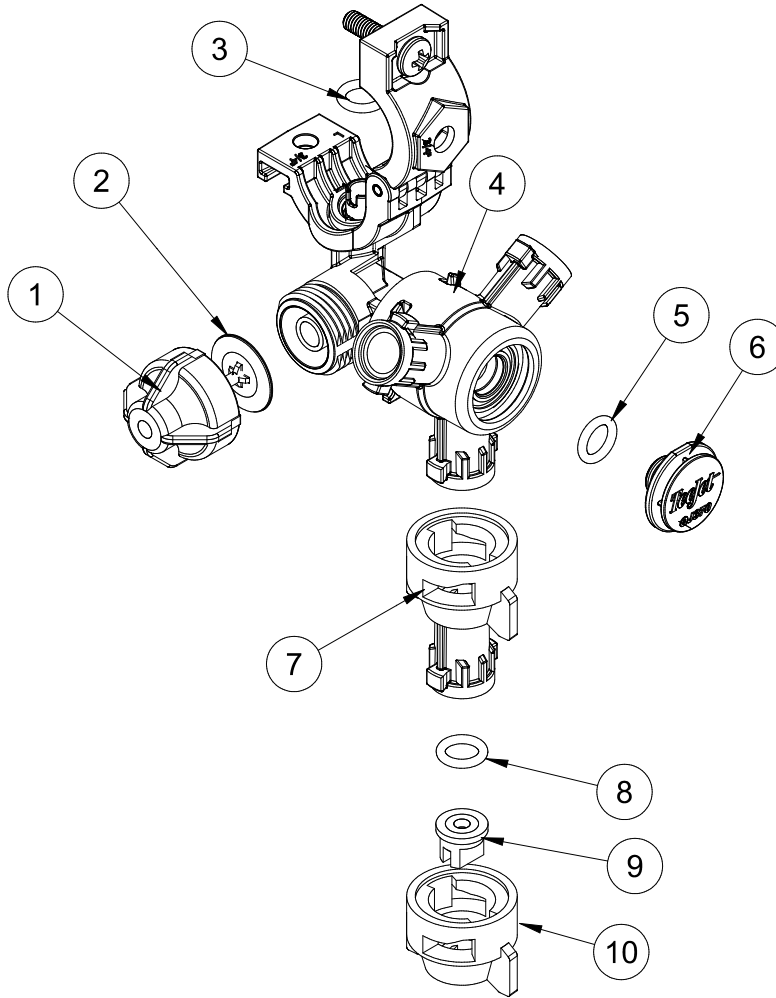

REF#	PART#	DESCRIPTION	QUANTITY
1*	16-988	Cap Assembly	1
2*	16-920-06	Diaphragm, EPDM	1
3*	16-920-03	O-ring	1
4*	33-563	Nozzle Body (includes all * items)	1
5*	33-563-03	O-ring, Viton	1
6*		Plug	1
7	20-779	Nozzle Tip Extension	1
8	16-800	Viton Gasket	1
9	33-554	Nozzle Tip - White (XR11008-VS)	1
10	33-538	Cap - White	1

Quantity is per nozzle body. For 15' booms multiply quantity by 9.
 Quantity is per nozzle body. For 18' booms multiply quantity by 11.

Nozzles are located 20" (51 cm) apart on the right, left, and center tubes. Nozzles are 20" high off ground.

20-946/20-954 NOZZLE 1115-AG/1118-AG DRAWING

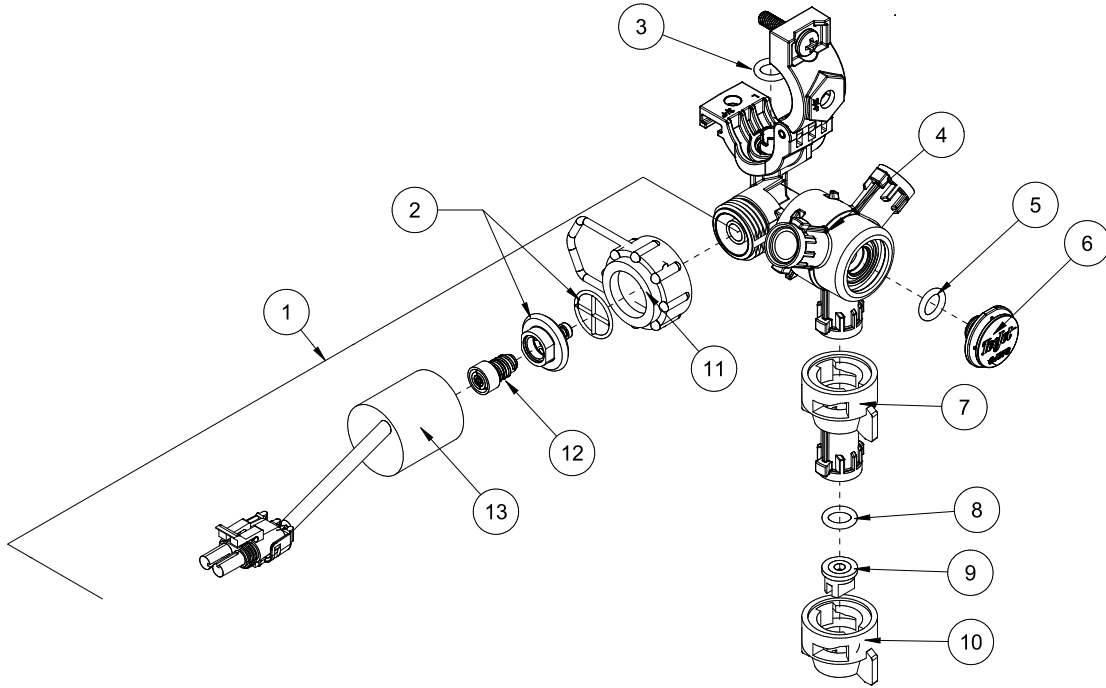

REF#	PART#	DESCRIPTION	QUANTITY
1	20-934	Valve Assembly Solenoid(includes all ** items)	1
2**	20-934-01	Orifice Insert Service Kit (diaphragm , cap, o-ring)	1
3*	16-920-03	O-ring	1
4*	33-563	Nozzle Body (includes all * items)	1
5*	33-563-03	O-ring, Viton	1
6*		Plug	1
7	20-779	Nozzle Tip Extension	1
8	16-800	Viton Gasket	1
9	20-837	Turbo Twinjet Nozzle Tip, Cap & Gasket - Gray	1
10	20-838	Cap - Gray	1
11**	20-934-03	Locking Ring and Clip	1
12**	20-934-02	Plunger with spring	1
13**	20-934-04	12W Coil	1
	20-946	LH Body Assembly (includes all * items)	1
	20-954	RH Body Assembly (includes all * items)	1
NS	20-944	Drop harness, Solenoid (6 drops per harness) (15' boom takes 3. 18' & 20' boom takes 4)	3or4

Quantity is per nozzle body. For 15' booms multiply quantity by 17.
 Quantity is per nozzle body. For 18' booms multiply quantity by 21.
 Quantity is per nozzle body. For 20' booms multiply quantity by 23.

Nozzles are located 10" (25 cm) apart on the right, left, and center tubes. Nozzles are 20" high off ground.

Accessories

15-835 TANK RINSING DEVICE

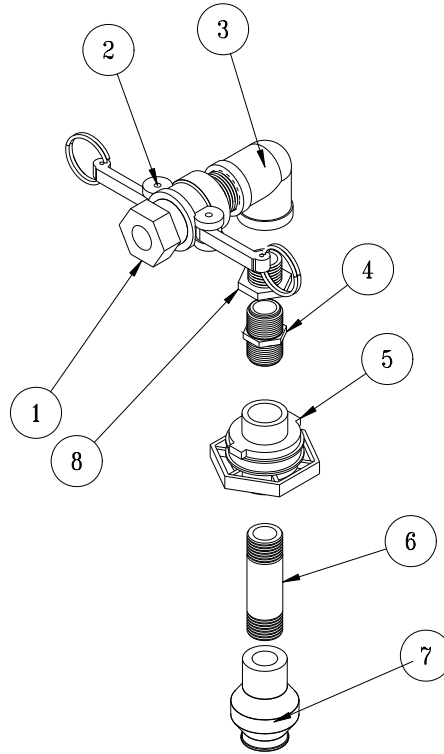

REF#	PART#	DESCRIPTION	QUANTITY
1	16-961	1" Adapter	1
2	16-962	1" Coupler	1
3	16-864	1" FTP Elbow	1
4	16-158	Close Nipple	1
5	16-150	Double Thread Fitting	1
6	16-172	4" Nipple	1
7	15-834	Tank Rinsing Nozzle	1
8	16-163	Reducer Bushing	1

Drill 1³/₄" hole 5" from outside edge of cover.

Install Tank Rinsing kit as shown, with the Double Thread Fitting (Ref 5) going into the cover.

Basket Must be removed During Use.

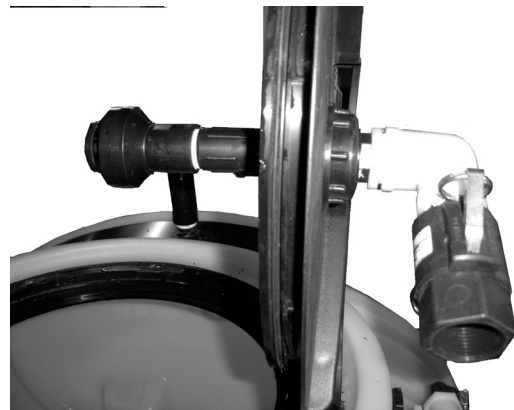

10-821 WATER FILL METER KIT

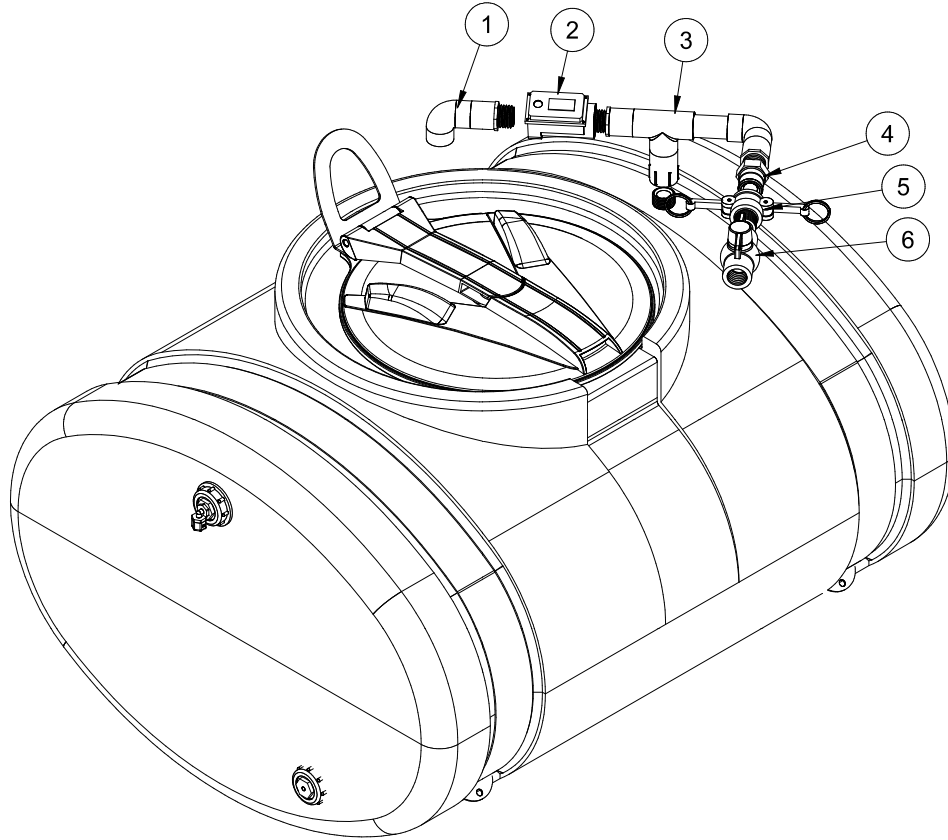

REF #	PART #	DESCRIPTION	QUANTITY
1	10-651	Filler Outlet	1
2	14-804	Water Meter	1
3	10-822	Filler Inlet	1
4	16-962	Quick Coupler (already on machine)	1
5	16-961	Quick Coupler (already on machine)	1
6	18-448	1" Ball Valve (already on machine)	1

1. Thoroughly flush the service line upstream of the meter to remove dirt and debris.
2. Set meter in-line.
3. Make sure the water flow follows the arrow cast on the meter body.
4. The DLJ Meter is for use **only** with **COLD WATER** up to 122°F (50°C)
5. Slowly open any upstream valves to prevent damage to the meter.

Gallons to Cubic feet Conversion :

Multiply gallons reading by 0.1337 to get cubic feet.

There are 7.48052 gallon per cubic foot.

15-967 HOSE REEL MOUNT

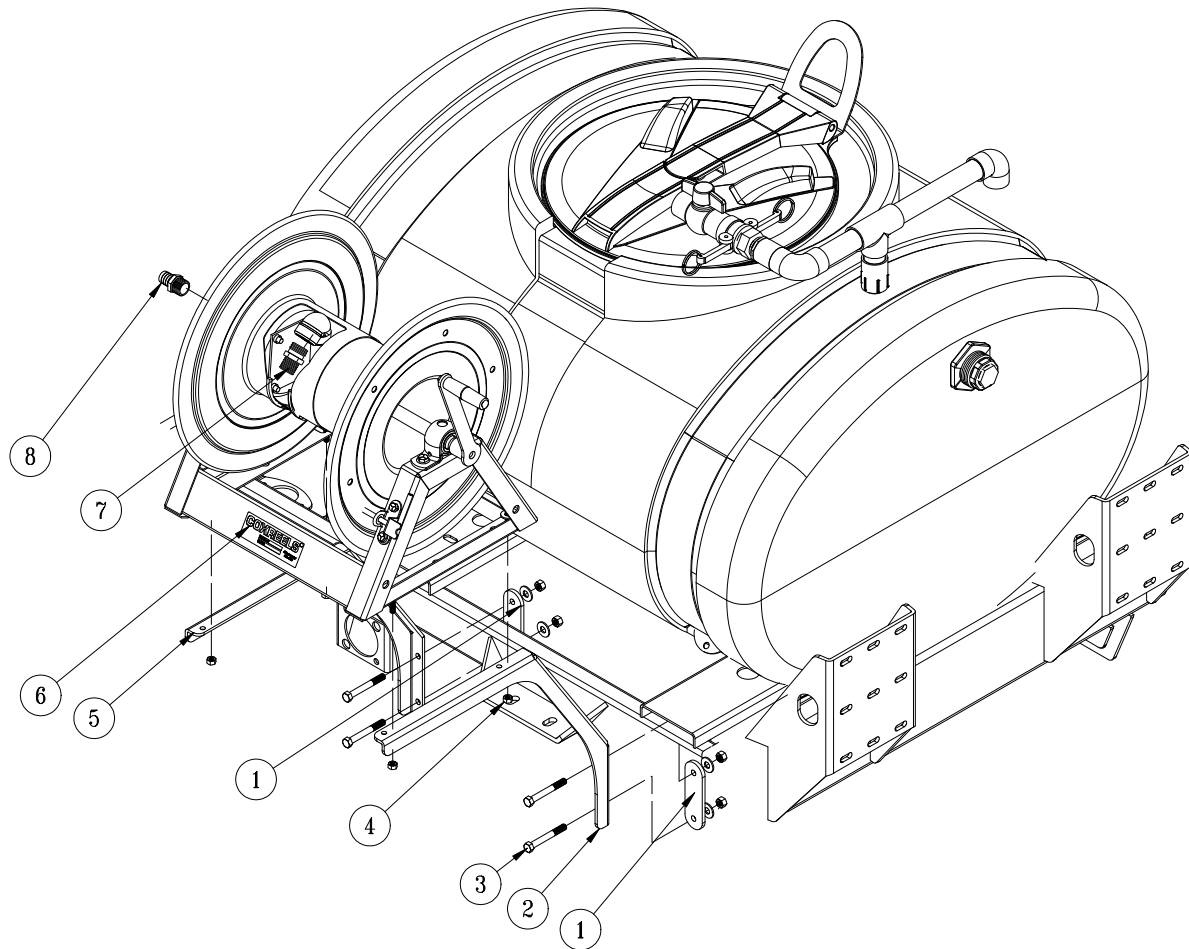

REF#	PART#	DESCRIPTION	QUANTITY
1	20-799	Backing Plate	2
2	20-788	Rear Hose Reel Mount	1
3	HB-38-16-300	Hex Bolt, $\frac{3}{8}$ - 16 x 3	4
	HNTL-38-16	Nylon Lock Nut, $\frac{3}{8}$ - 16	4
	HW-38	Flat Washer, $\frac{3}{8}$	4
4	HB-516-18-150	Hex Bolt, $\frac{5}{16}$ - 18 x 1 $\frac{1}{2}$	4
	HNTL-516-18	Nylon Lock Nut, $\frac{5}{16}$ - 18	4
	HW-516	Flat Washer, $\frac{5}{16}$	4
5	20-789	Front Hose Reel Mount	1
6	16-906	Electric Hose Reel	1
	16-129	Manual Hose Reel	1
7	16-295	Hose Fitting	1
8	18-249	Brass Fitting, $\frac{3}{4}$ MPT x $\frac{3}{4}$ HB	1

1. Wear protective clothing when draining the tank and taking apart the lines.
2. Drain tank and spray system in a safe and approved method ensuring that no chemical or water remain in tank as you will be taking apart lines.
3. Turn off machine, set park brake, remove key from ignition and block wheels.
4. Install front mount(Ref. 2) using backing plate(Ref. 1) and two $\frac{3}{8}$ x 3 hex bolts, nuts and washers. Repeat with rear mount(Ref. 5). Rear mount should go under tank mount channel. Leave loose to reposition.
5. Position hose reel on mounts. Use four hex bolts $\frac{5}{16}$ - 18 x 1 $\frac{1}{2}$ and four $\frac{5}{16}$ - 18 nylon lock nuts to hold in place. Tighten hex bolts.
6. Tighten mount bolts(Ref 3).
7. Put 18-249 barb fitting(Ref. 8) into hose reel end and 16-295 hose fitting(Ref 7) into center of hose reel.

16-129 MANUAL HOSE REEL DRAWING

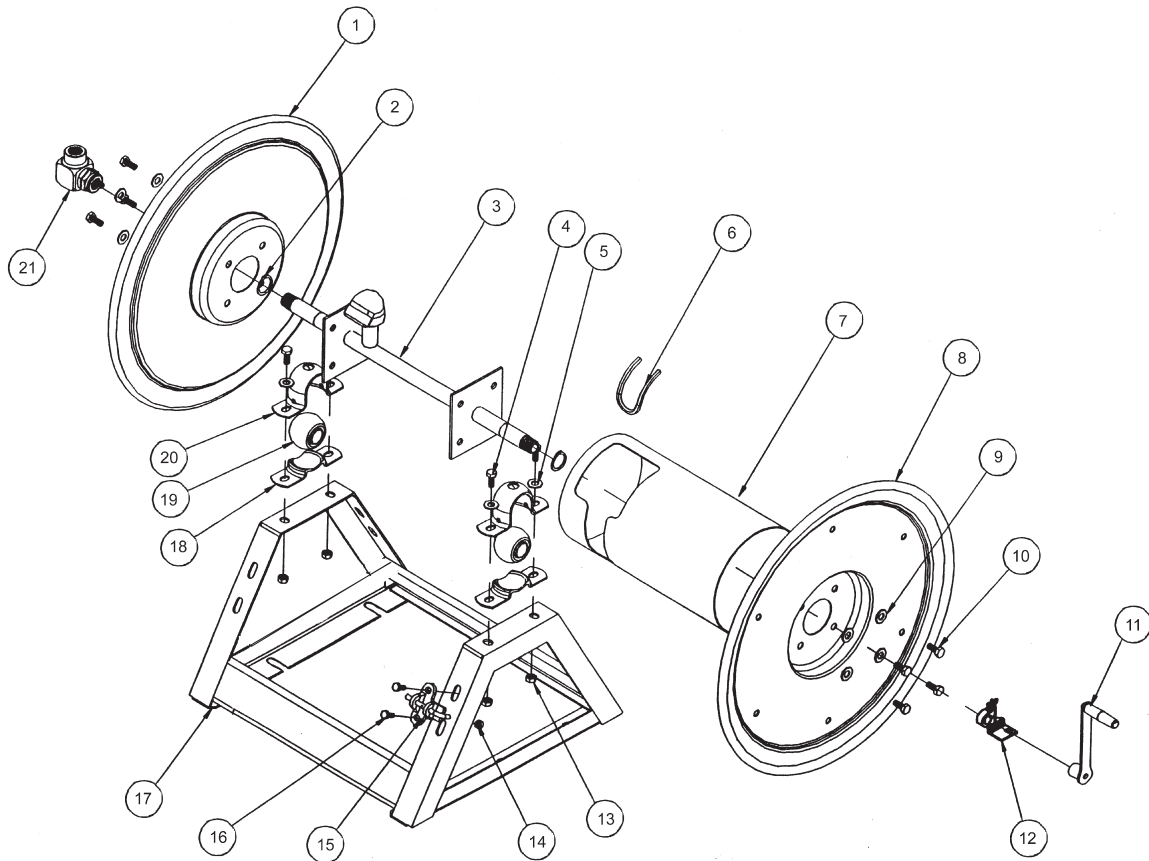

REF#	PART#	DESCRIPTION	QUANTITY
1	16-129-11	Disc, 17 ¹ / ₂	1
2	16-906-25	Retaining Ring	2
3	16-906-22	Axle Assembly, ³ / ₄	1
4	HB-38-16-100	Hex Bolt, ³ / ₈ - 16 x 1	4
5	HW-38	Flat Washer, ³ / ₈	4
6	16-906-27	Trim, Drum Edge	1
7	16-906-21	Drum Center	1
8	16-906-20	Disc, 17 ¹ / ₂ Crank Side	1
9	HWL-516	Lockwasher, ⁵ / ₁₆	8
10	HB-516-18-075	Hex Bolt, ⁵ / ₁₆ - 18 x ³ / ₄	8
11	16-129-09	Crank Assembly, ³ / ₄	1
12	16-129-10	Brake Assembly, ³ / ₄	1
13	HNTL-38-16	Lock Nut, ³ / ₈ - 16	4
14	HNTL-516-18	Lock Nut, ⁵ / ₁₆ - 18	2
15	16-129-08	Lock Pin Assembly	1
16	HB-516-18-075	Hex Bolt, ⁵ / ₁₆ - 18 x ³ / ₄	2
	HW-516	Flat Washer, ⁵ / ₁₆	2
17	16-129-07	Frame Assembly	1
18	16-906-08	Mounting Pillow Block (Bottom)	2
19	16-906-24	Bearing	2
20	16-906-07	Mounting Pillow Block (Top)	2
21	16-906-23	Swivel Assembly, ³ / ₄	1
	16-906-30	Seal Kit (For 16-906-23)	1

16-906 ELECTRIC HOSE REEL DRAWING

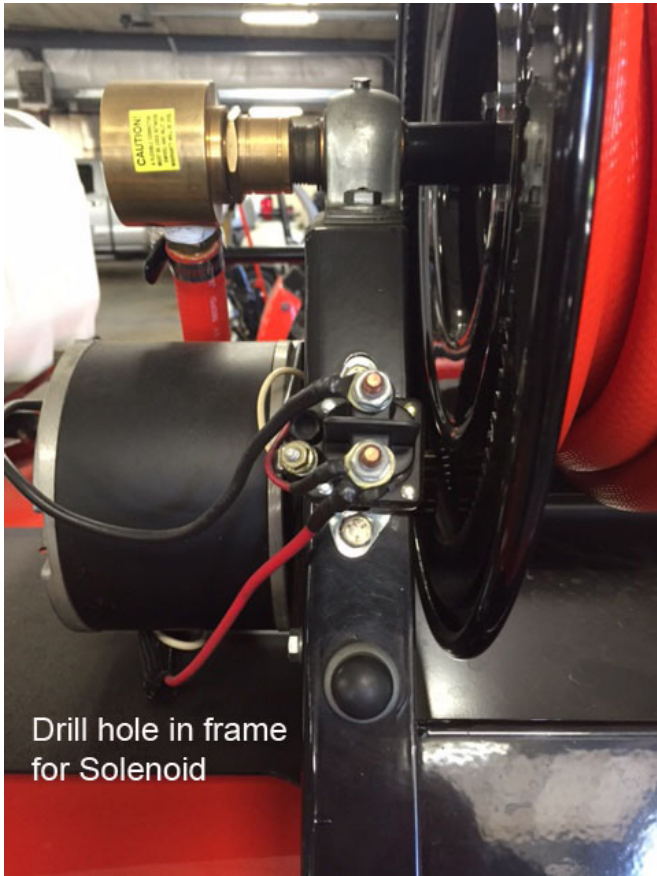
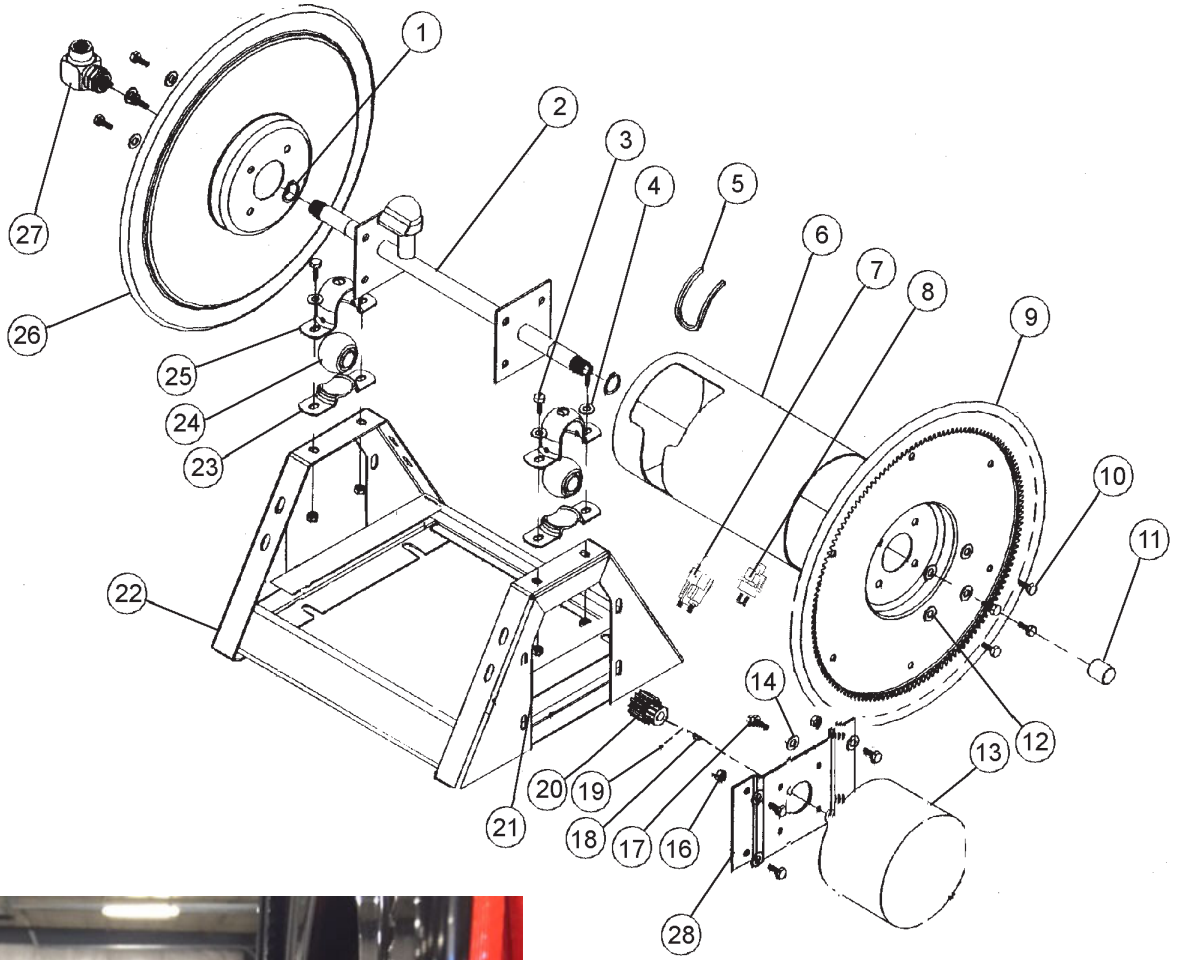

Drill hole in frame
for Solenoid

16-906 ELECTRIC HOSE REEL PARTS LIST

REF#	PART#	DESCRIPTION	QUANTITY
1	16-906-25	Retaining Ring	2
2	16-906-22	Axle Assembly	1
3	HB-38-16-100	Hex Bolt, $\frac{3}{8}$ - 16 x 1	4
4	HW-38	Flat Washer, $\frac{3}{8}$	4
5	16-906-27	Trim, Drum Edge	1
6	16-906-21	Drum Center	1
7	13-750	Solenoid	1
	HB-14-20-075	Hex Bolt, $\frac{1}{4}$ - 20 x $\frac{3}{4}$	2
	HWL-14	Lockwasher, $\frac{1}{4}$	2
	HN-14-20	Hex Nut, $\frac{1}{4}$ - 20	2
8	33-251	Switch	1
9	16-906-19	Disc and Gear Assembly	1
10	HB-516-18-075	Hex Bolt, $\frac{5}{16}$ - 18 x $\frac{3}{4}$	8
11	16-906-26	Pipe Cap, $\frac{3}{4}$	1
12	HWL-516	Lockwasher, $\frac{5}{16}$	8
13	16-906-15	Motor 12VDC	1
14	HW-516	Flat Washer, $\frac{5}{16}$	4
16	HNTL-516-18	Lock Nut, $\frac{5}{16}$ - 18	4
17	HB-516-18-100	Hex Bolt, $\frac{5}{16}$ - 18 x 1	4
18	16-906-17	Key	1
19		Set Screw	2
20	16-906-29	Pinion	1
21	HNTL-38-16	Lock Nut, $\frac{3}{8}$ - 16	4
22	16-906-18	Frame Assembly	1
23	16-906-08	Mounting Pillow Block (Bottom)	2
24	16-906-24	Bearing	2
25	16-906-07	Mounting Pillow Block (Top)	2
26	16-906-20	Disc, 17 $\frac{1}{2}$	1
27	16-906-23	Swivel Assembly, $\frac{3}{4}$	1
	16-906-30	Seal Kit (For 16-906-23)	1
28	16-906-28	Bracket 12VDC	1
	16-982	Electric Hose Reel (only)	1

ELECTRIC HOSE REEL WIRING DIAGRAM

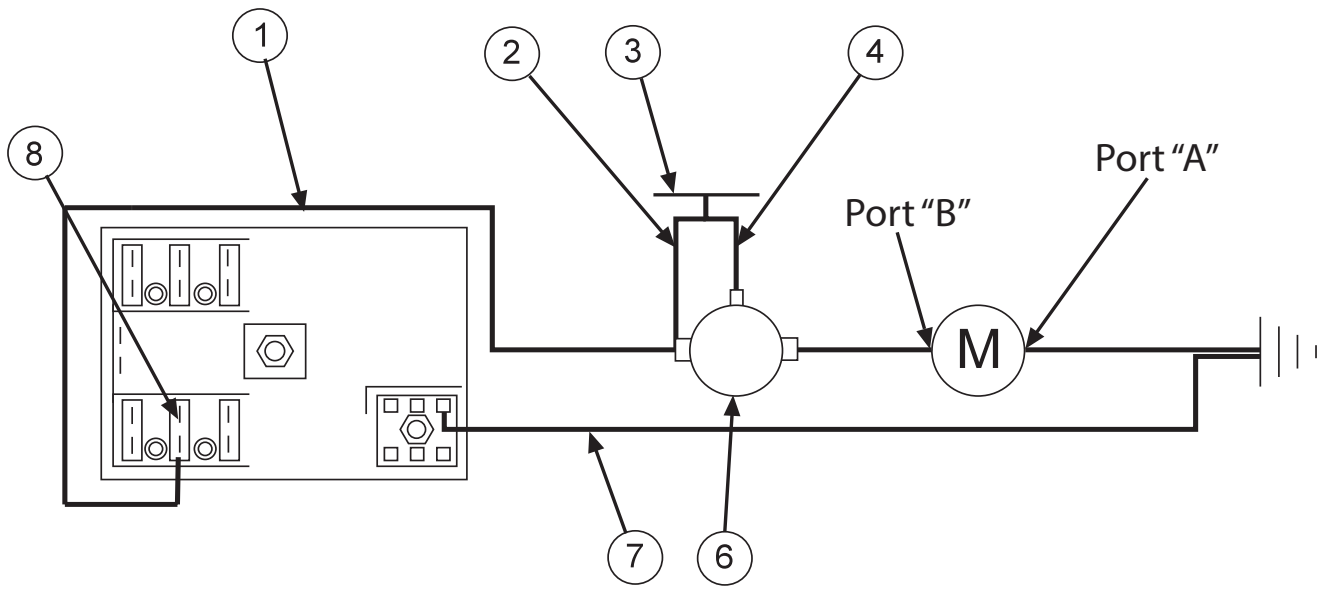

REF#	PART#	DESCRIPTION	QUANTITY
1	8843	Flex guard $\frac{3}{8}$ ID	143"
	8919	10GA Red Wire 144"	144"
	8901	Slide-On Connector	1
2	16-979	Wire, Switch to Solenoid Hot Terminal	1
3	33-251	Push Button Switch	1
4	16-978	Wire, Switch to Solenoid Start Terminal	1
6	13-750	Solenoid	1
SOLENOID TERMINALS			
	HN -516-24	$\frac{5}{16}$ - 24 Hex Nut	2
	HN -10-32	10 - 32 Hex Nut	1
7	8931	10GA White Wire 144"	144"
	8901	Slide-On Connector	1
8	33-273	Auto Blade Type Fuse 30Amp	1

CONNECTION INSTRUCTIONS

Route wire harness along side of tank and over to fuse block taking care to stay clear of moving parts or hot engine components. Cut off excess wire and strip back $\frac{3}{8}$ ". Place one 8963 heat shrink ($\frac{1}{4} \times 1\frac{1}{4}$ ") on each wire before crimping 8901 slide on connectors to the red and white wires. Connect the two wires to the fuse block first the red to the (+) positive and the white to the (-) negative. Put the 33-273 auto blade type fuse (30 amp) into fuse block.

⚠ WARNING

Make certain you are connecting positive (+) to positive; negative (-) to negative while attaching power leads. If you do not observe polarity, damage will result to electrical components.

Use Dielectric Grease On All Electrical Connections

Accessories

HOSE REEL ADJUSTMENTS

OPERATIONAL CHECK:

1. Pull hose off drum at least one full revolution. A clicking noise should be heard from locking mechanism.
2. Let the hose retract.
3. Pull the hose off until the first click is heard. Drum should lock when the hose tension is removed.
4. Continue pulling the hose, no more than one revolution, until no clicking is heard. Hose should rewind when tension is removed.

HOSE REPLACEMENT PROCEDURE:

1. Facing swivel, turn the hose drum clockwise until all of the hose is removed from the drum and the drum is held by locking mechanism. Make sure spring is locked.
2. Remove hose clamps and disconnect hose from swivel. Remove old hose.
3. Insert new hose through roller guide, connect to swivel and reinstall hose clamps. Use spring guard over hose to protect the hose from being cut by the drum.
4. Remove check ball from old hose and install on replacement hose.
5. Carefully, keeping the tension on the hose, pull the hose to release the locking mechanism. Let the hose wind on the drum.

HOSE REEL PLUMBING MANUAL SPRAY SYSTEM

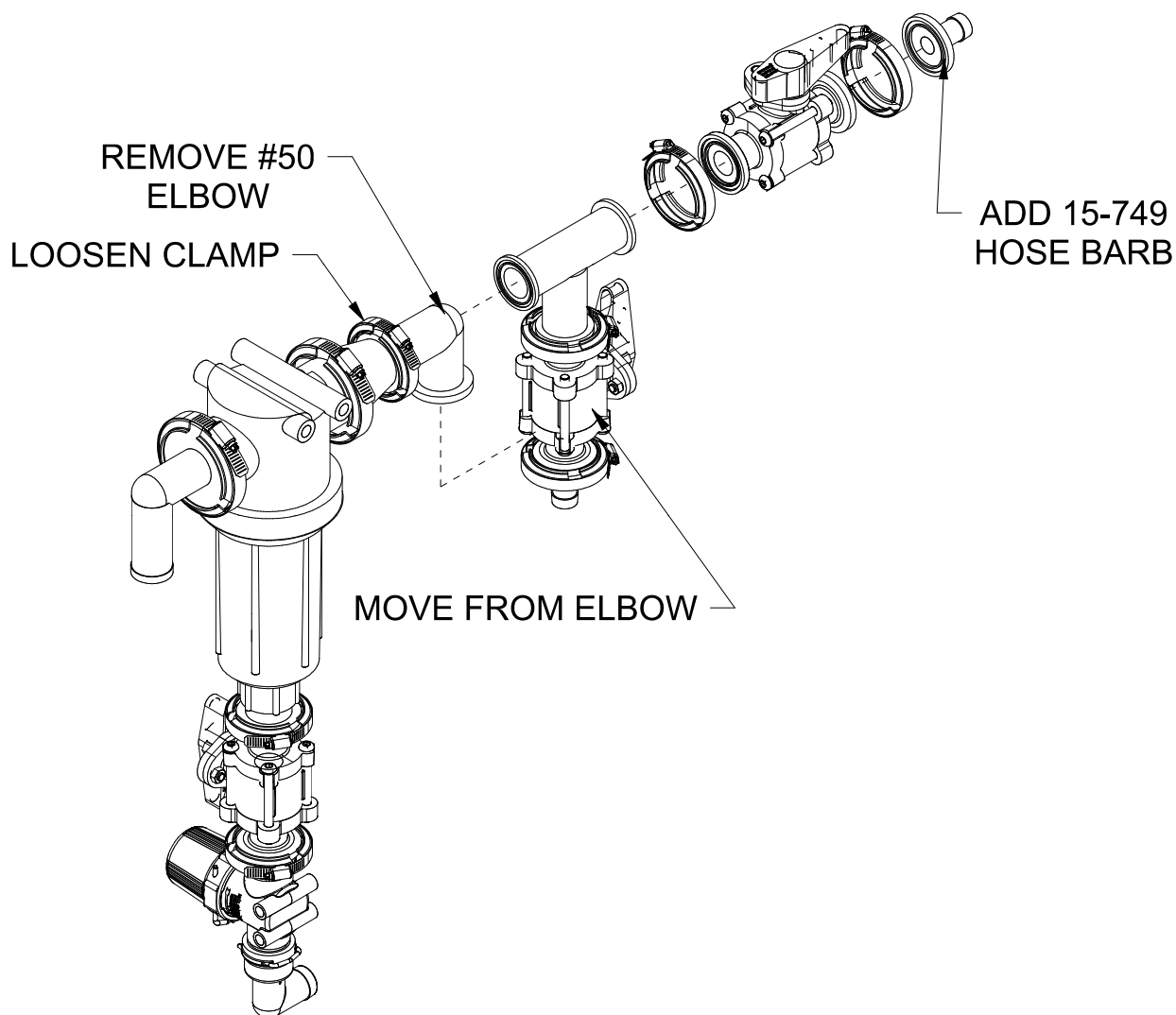

INSTALLATION INSTRUCTIONS

1. The hose reel is plumbed just off the filter.
2. Remove the blank from the end of the ball valve and add the 15-749 hose barb. Tighten clamp.
3. Route the $\frac{3}{4}$ " hose from the hose barb you just installed to the hose barb on the hose reel. We provide 90" of hose. You may cut the hose to desired length to make a good fit. Secure with an 18-140 hose clamp on each end. There are plastic clamp covers to put on end of the hose clamps.
4. Secure hose to machine with nylon ties.

HOSE REEL PLUMBING TEEJET® SPRAY SYSTEM

INSTALLATION INSTRUCTIONS

1. The ball valve is already installed. Loosen the clamp holding the blank cover on. Remove the blank cover from the ball valve. Install the hose barb as shown. Tighten all clamps
2. Route the $\frac{3}{4}$ " hose from the hose barb on the ball valve to the hose barb on the hose reel. We provide 90" of hose. You may cut the hose to desired length to make a good fit. Secure with a 18-040 hose clamp on each end. There are plastic clamp covers to put on end of the hose clamps.
3. Secure the hose to the machine with a nylon ties.
4. There may be parts left over that you will not need.

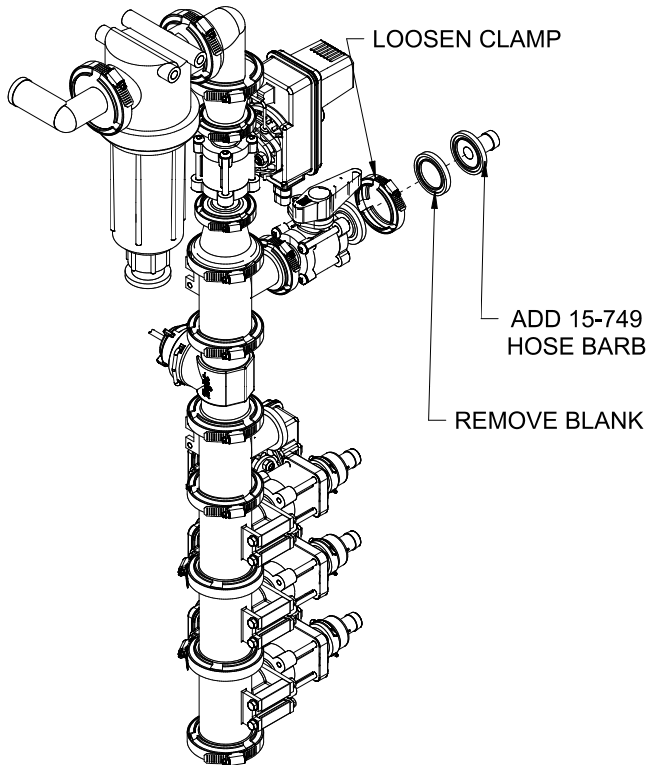

TeeJet® Radion and Star Command Plumbing

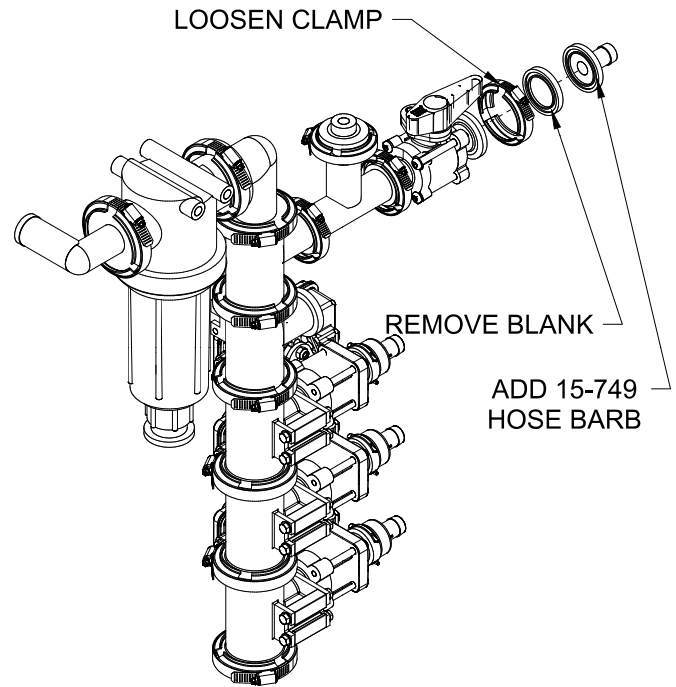

744 Plumbing

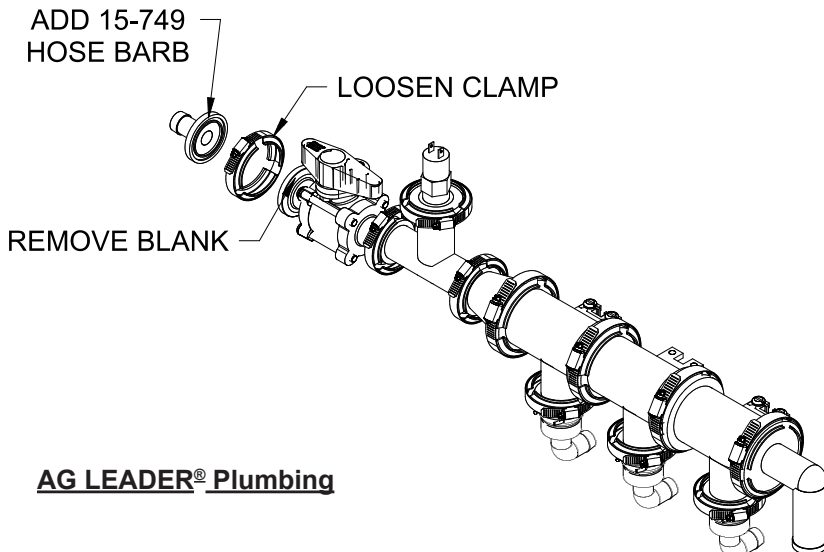

AG LEADER® Plumbing

30-006 FRESH WATER WASH TANK - REAR MOUNT

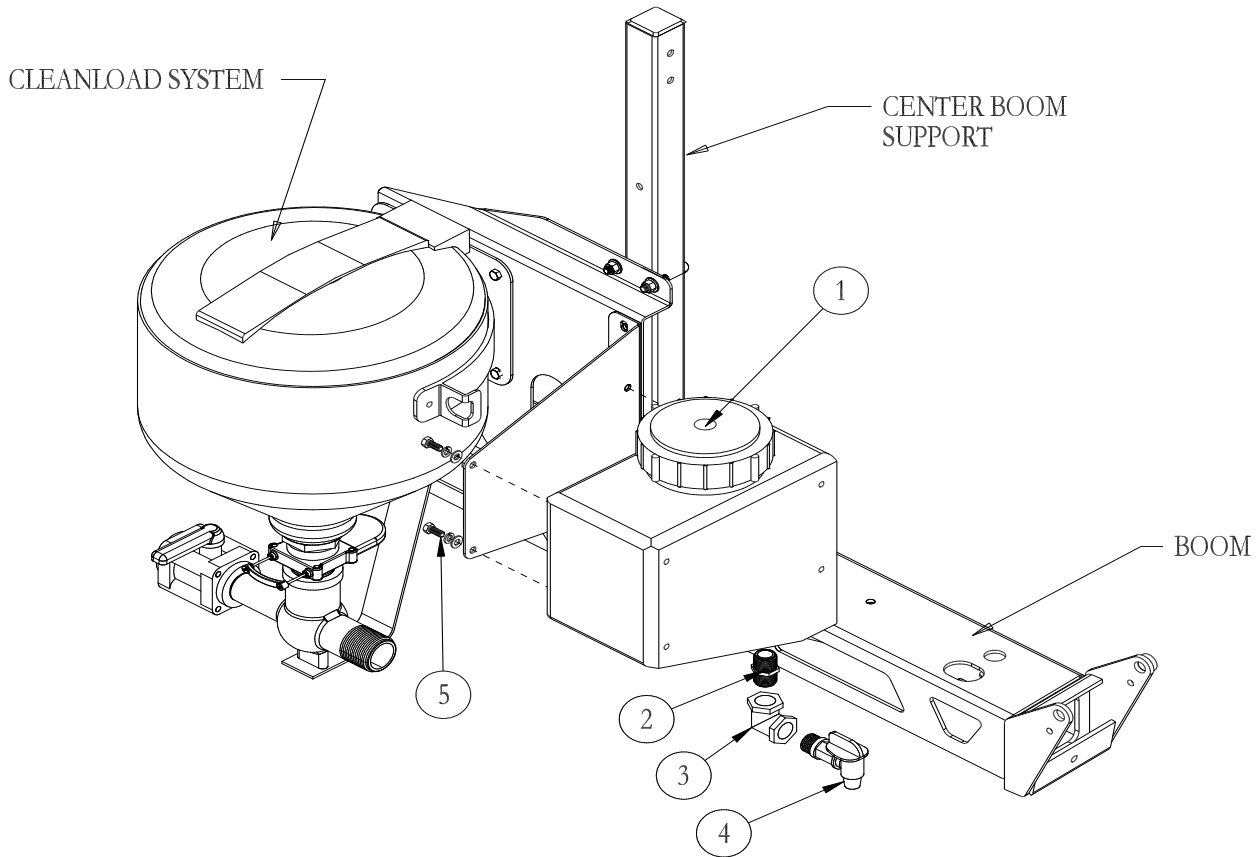

REF#	PART#	DESCRIPTION	QUANTITY
1	10-234	Wash Tank	1
2	16-158	Close Nipple	1
3	16-151	Elbow	1
4	16-960	Spigot	1
5	HB-516-18-075	Hex Bolt, $\frac{5}{16}$ - 18 x $\frac{3}{4}$	4
	HWL-516	Lockwasher, $\frac{5}{16}$	4
	HW-516	Flat Washer, $\frac{5}{16}$	4

1. Fresh Water Wash Tank mounts on the rear of all the machines.
2. The Bracket is already attached to the Super Boom center boom post.
3. Install the nipple (Ref 2), elbow (Ref 3) and spigot (Ref 4) into the bottom of wash tank (Ref 1). Use thread tape on all threads.
4. Mount the tank onto the mount bracket using four $\frac{5}{16}$ x $\frac{3}{4}$ bolts, washers and lock washers. Tighten.
5. Rinse tank with clear water and check for leaks around fittings.

This tank is for fresh clear water ONLY. Do not put chemicals in this tank.

15-965 FOAM MARKER TANK MOUNT

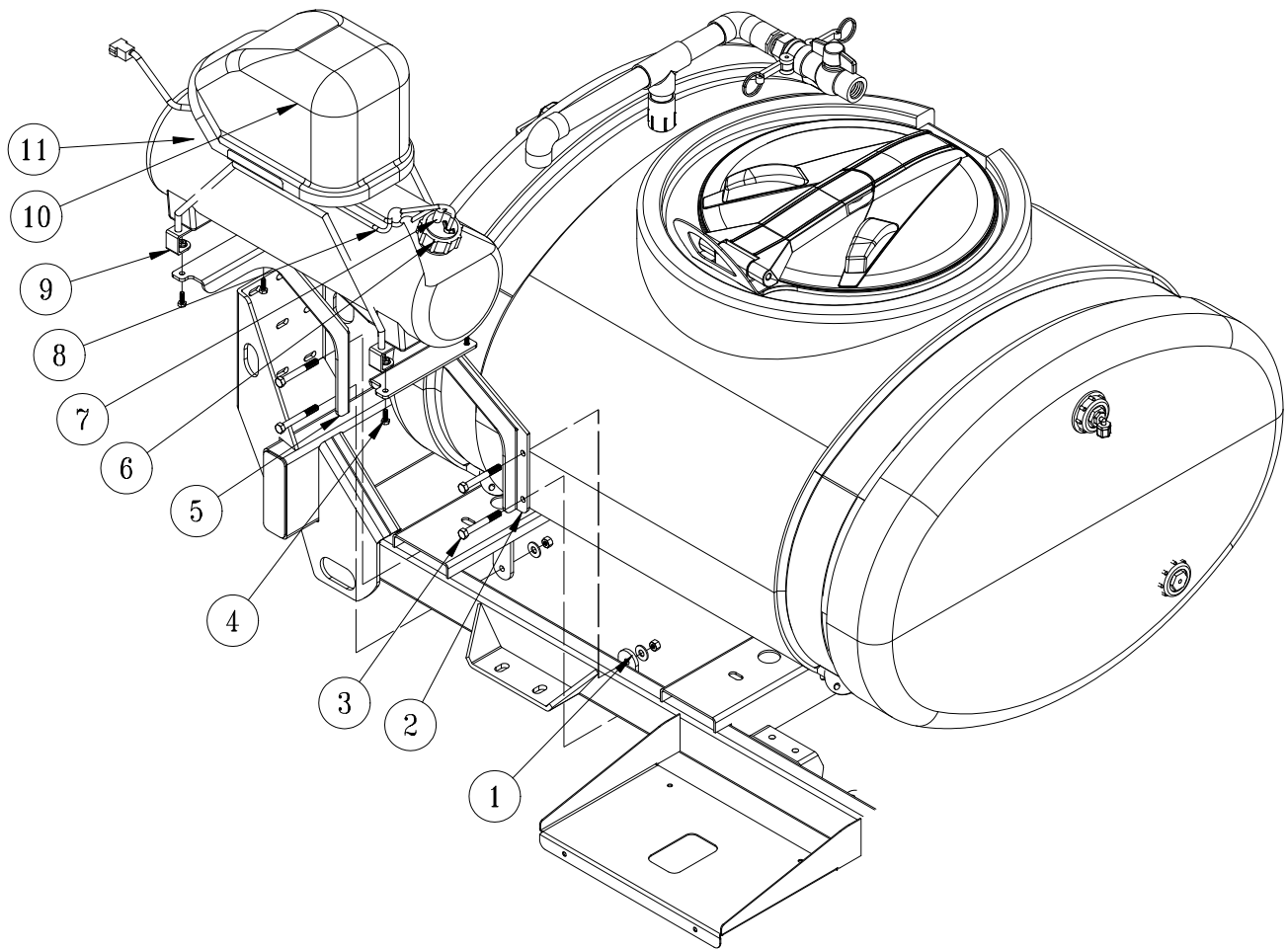

REF#	PART#	DESCRIPTION	QUANTITY
1	20-799	Backing Plate	2
2	20-791	Front Foamer Mount	1
3	HB-38-16-300	Hex Bolt, $\frac{3}{8}$ - 16 x 3	4
	HNFL-38-16	Nylon Lock Nut, $\frac{3}{8}$ - 16	4
	HW-38	Flat Washer, $\frac{3}{8}$	4
4	HB-14-20-075	Hex Bolt, $\frac{1}{4}$ - 20 x $\frac{3}{4}$	4
	HNFL-14-20	Flange Whiz-loc Nut, $\frac{1}{4}$ - 20	4
5	20-790	Rear Foamer Mount	1
6	14-284-02	Cap Assembly	1
7		Clear Tube	1
8		Blue Tube	1
9	14-291-04	Tank Bracket	2
10	14-291-03	Compressor Only	1
	14-291-01	Black Cover	1
11	14-291-02	Foamer Tank	1
6-11	14-291	Foamer (includes parts 6-11)	1

15-965 FOAM MARKER CONTROL PANEL

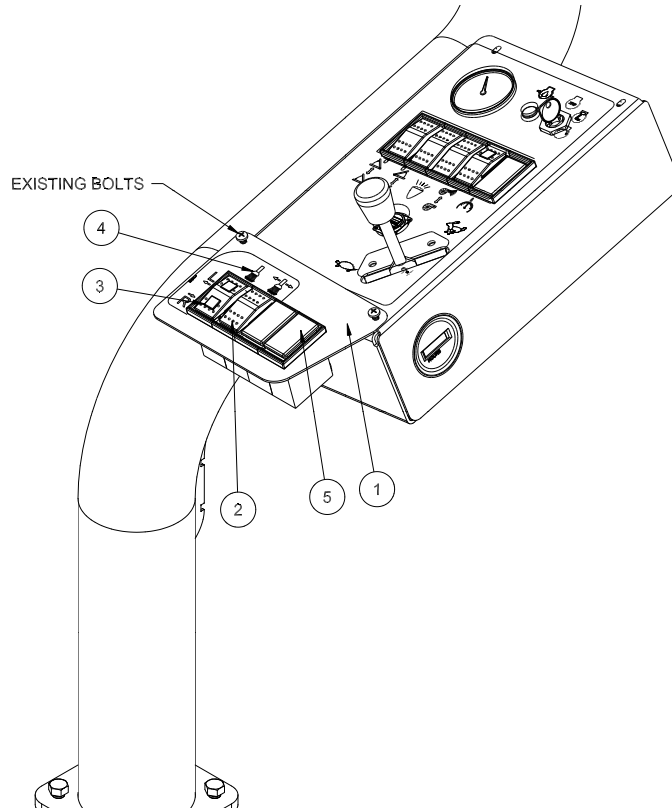

REF#	PART#	DESCRIPTION	QUANTITY
1	10-739	Switch Mount Plate	1
	15-725	Panel Mount End	2
2	15-782	Switch, Unlit	1
	15-727	Rocker, No Light	1
3	15-918	Switch, 2 Red LED	1
	15-917	Rocker, 2 Red Lenses	1
4	30-374	Decal, Foamer	1

⚠ WARNING

Safety: Before working on machine stop engine, set park brake, remove key from ignition and block wheels. Disconnect negative (-) battery terminal.

1. Place decal(Ref 4) on Switch mount plate. Place panel mount ends in mount plate.
2. Mount switches (Ref 2 & 3) to switch mount plate (Ref 1) as shown above. Mount the switch mount plate(Ref 1) on the side control panel using existing bolts.

Tank Mount Drawing

1. Position the front foamer mount(Ref 2) and one backing plate (Ref 1) on the right hand side of the mainframe ahead of the rear axle, secure using two $\frac{3}{8}$ x 3 bolts, flat washers and lock nuts. Repeat with the Rear Foamer Mount(Ref 5). *Leave loose enough to reposition when mounting the Foamer(Refs 6-11).*
2. **For 1110** - The rear mount should go under tank mount channel.
3. Place Foamer unit(Refs 6-11) onto the front and rear mounts. Using the $\frac{1}{4}$ x $\frac{3}{4}$ bolts and $\frac{1}{4}$ flange Lock nuts. Fasten foamer to mounts. Tighten hardware.
4. Tighten hardware securing foamer mounts to the mainframe.

FOAM MARKER WIRING

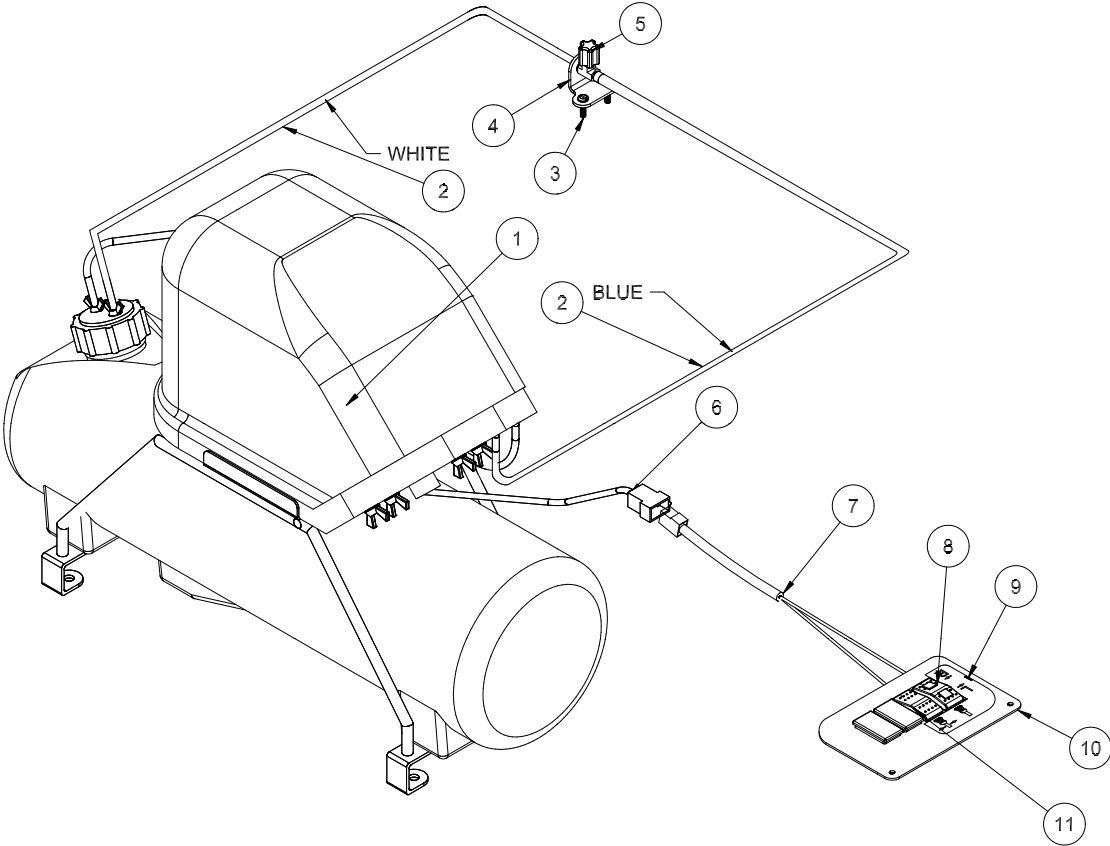

REF#	PART#	DESCRIPTION	QUANTITY
1	14-291-03	Compressor	1
2	15-507	Tubing -Blue and white	1
3	HSM-10-32-075	Machine Screw, #10-32 x 3/4	2
	HNFL-10-32	Flange Whiz-loc Nut, #10-32	2
4	20-769	Mount Bracket	1
5	14-699	Male Coupler	1
	14-291-09	Blue Fly Nut	1
	14-702	Red Washer	1
6	15-504-04	Foam Marker Wiring Harness	1
7	32-574	Foamer Wire Harness	1
8	15-918	Switch, 2 Red LED	1
	15-917	Rocker, 2 Red Lenses	1
9	30-374	Decal, Foamer	1
10	10-739	Switch Mount Plate	1
11	15-782	Switch, Unlit	1
	15-727	Rocker, No Light	1

INSTALLATION

1. Connect the compressor wire harness (Ref 6) to the switches using the wire harness (Ref 7).
2. Use dielectric grease on all electrical connections. Route the wire harness to the battery and out of the way of any heat or moving parts. Use nylon ties as needed. Connect the wire harness to the battery. Red to positive(+), black to negative(-).

Accessories

FOAMER NOZZLE MOUNT DRAWING

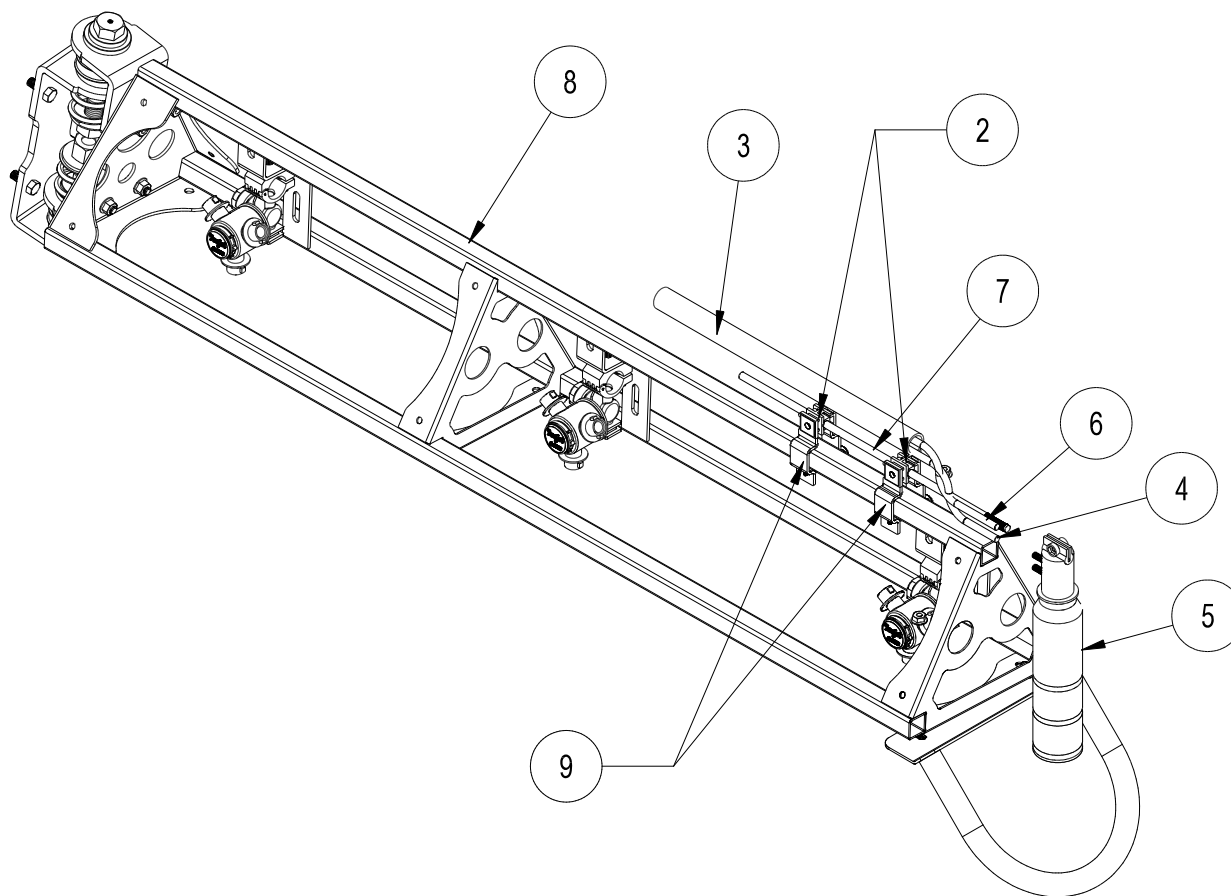

Accessories

REF#	PART#	DESCRIPTION	QUANTITY
2	16-987	Foam Nozzle Mounting Kit	1 per boom
3	15-507	Foamer Tubing	1
4		Clear Tubing	
5	15-511	Foam Nozzle	2
6		Blue Tubing	
7	15-510-01	Nozzle Mounting Rod	2
8		Boom	
9	16-795	Square Clamp	4

INSTRUCTIONS

1. Slide hose clamp onto drop tube of foam nozzle and attach restricter bell.
2. Place splined end of Nozzle mounting rod (Ref 7) into top of foam nozzle (Ref 5). Tighten screw.
3. Slide two foam nozzle mounts (Ref 2) onto the rod. Place square clamps (Ref 9) on foam nozzle mounts and mount the square clamps to the boom (Ref 8). Adjust foam nozzle mounts and clamps so nozzle assembly will clear end of boom. Tighten foam nozzle mounts and square clamps to prevent side to side movement. Do the same to the other side.
4. Being careful not to cut the tubing (Ref 3), cut the oversleeve back approximately 2" (5 cm) to expose blue (Ref 6) and clear tubing (Ref 4).
5. Remove blue wing nut from top connector of foam nozzle and slide it on the blue tube with the threads facing toward end of tube. Slide blue tube all the way over the top of the small tube on foam nozzle. Slide wing nut back to the threads and hand tighten. Follow the same steps for the clear tube and tube nut.
6. Route the tubing along underside of main frame using tie downs as necessary.
7. Install opposite ends of air-liquid tubes to compressor, again cutting back the oversleeve approximately 2" (5 cm) and inserting blue and clear tubes for the left boom section into the tubing connectors (Ref A) on the right side of compressor as far as possible.
8. Follow the same steps for the right boom tubing. Notice the right boom is inserted into left side of compressor. To release tubing from compressor, hold black ring around tubing, and pull tube out.
9. Hose's must be routed on bottom of the boom square tubing.
10. Install hose guard using 2 drill screws (you may want to drill a $\frac{3}{16}$ pilot hole first).
11. Place another hose guard against first and install in same manner.
12. Repeat process for other boom side.
13. Connect small plastic electrical plug under compressor to electrical extension cable.
14. Cut cable and strip casing, allowing enough length to connect to fuse block.
15. Strip and connect slide on connectors to each wire and use the heat shrink.
16. Connect black negative (-) wire to the ground and connect red wire to the positive (+).
17. Insert 10 amp fuse into slot which red wire was attached to.

14-291 FOAMER REPLACEMENT PARTS

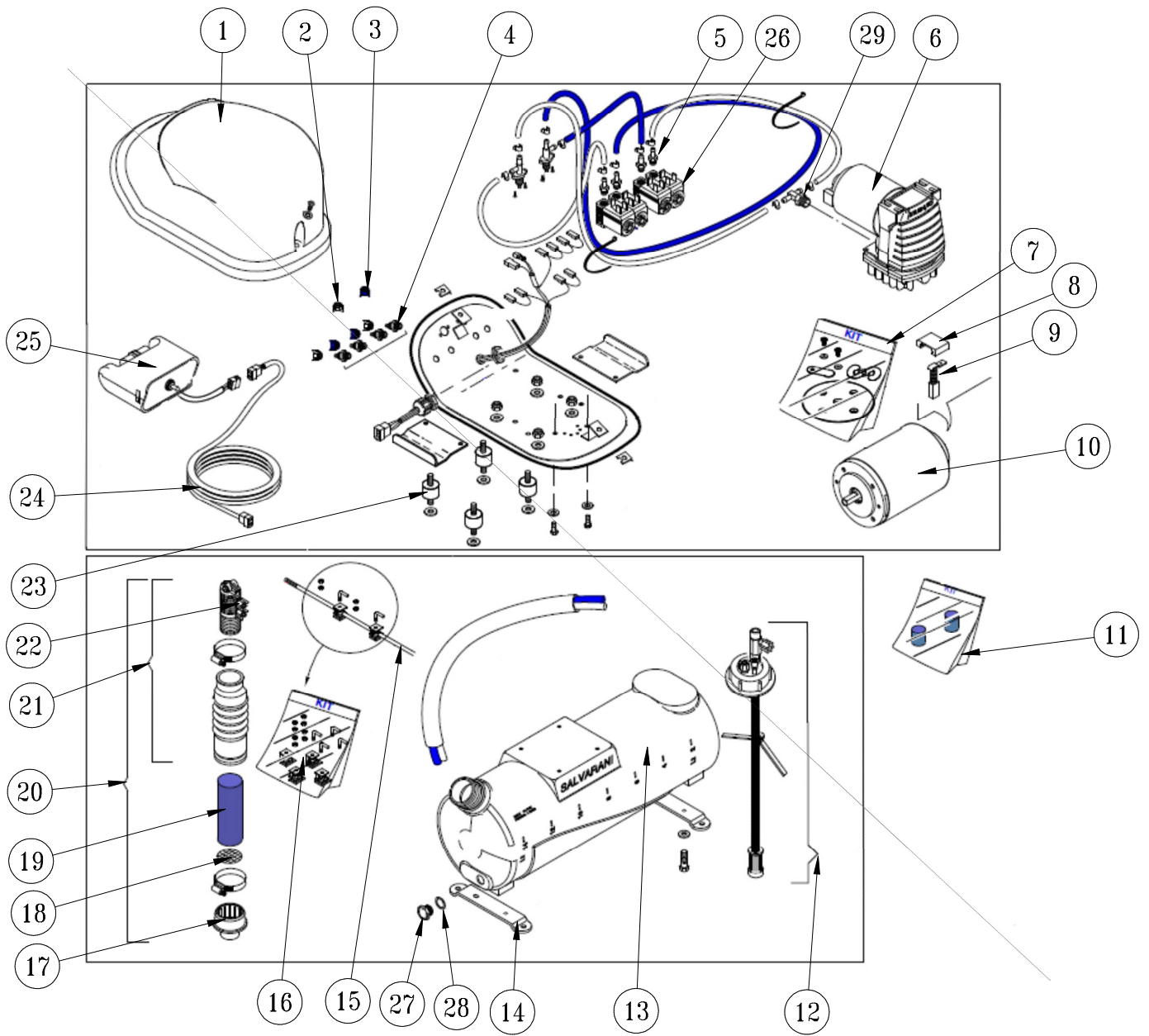

Accessories

14-291 FOAMER REPLACEMENT PARTS

REF#	PART#	DESCRIPTION	QUANTITY
1	14-291-01	Black Cover	1
2	14-291-08	White Fly Nut	1
3	14-291-09	Blue Fly Nut	1
4	14-284-10	Tubing Connector	1
5	14-291-17	M6 Tubing Connector	1
6	14-536	Compressor Complete	1
7	14-291-11	Diaphragm Replacement Kit	1
8	15-505-08	Brush Retainer	1
9	15-505-06	Brush	1
10	15-505-07	12V Electric Motor	1
11	15-511-02	Foam Sponge	1
12	14-284-02	Cap Assembly	1
13	14-291-02	Foamer Tank	1
14	14-291-04	Tank Brackets	2
15	15-510-01	Nozzle Mounting Rod	2
16	16-987	Foam Nozzle Mounting Kit	1
17	14-284-09	Foam Nozzle Reducer	2
18	15-511-09	Stainless Steel Screen	2
19	15-511-08	Long Foam Sponge	2
20	15-511	Foam Nozzle	2
21	15-511-07	Foam Nozzle Assembly	1
22	15-511-01	Foam Nozzle Sub Assembly	1
23	14-291-15	Shock Absorber	4
24	14-284-05	Extension Wire	1
25	14-291-05	Switch Box	1
	15-506-02	Switch	1
26	14-284-11	Solenoid Valve	4
27	14-291-19	Drain Plug	1
28	14-291-18	Drain Plug Seal	1
29	14-291-21	Tee, Hose Connector	1
NS	15-507	16M Blue & White Tubing	

15-968 20 GALLON RINSE TANK

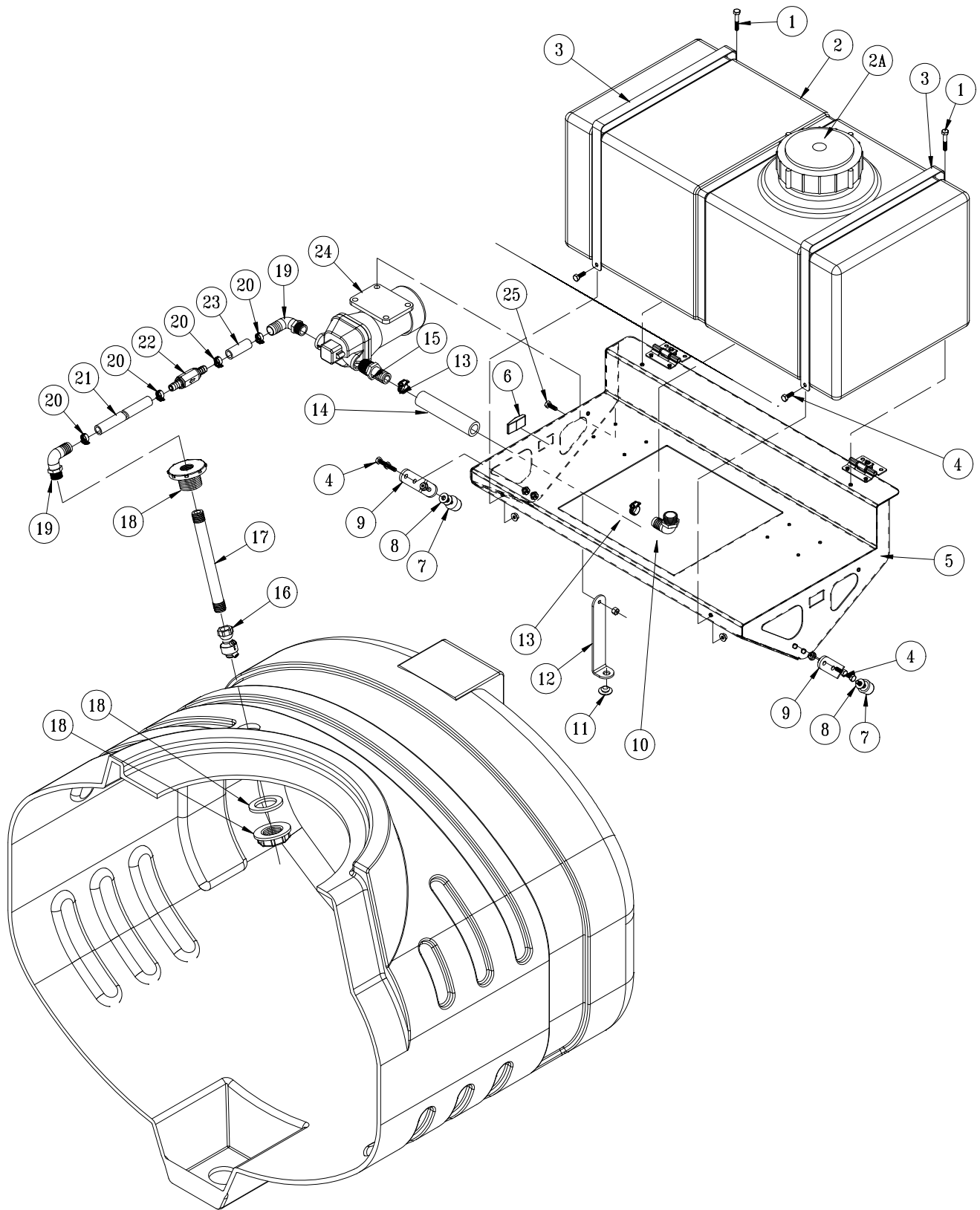

Accessories

15-968 20 GALLON RINSE TANK PARTS LIST

REF#	PART#	DESCRIPTION	QUANTITY
1	HB-14-20-150	Hex Bolt, 1/4 - 20 x 1 1/2	2
	HNFL-14-20	Flange Lock Nut, 1/4 - 20	2
2	20-797	20 Gallon Tank	1
2A	10-234-01	Replacement Cover	
3	20-800	Tank Strap	2
4	HB-14-20-075	Hex Bolt, 1/4 - 20 x 3/4	6
	HNFL-14-20	Flange Lock Nut, 1/4 - 20	6
5	20-792	Rinse Tank Mount	1
6	15-726	Lighted Rocker Switch	1
	15-917	Red Rocker	1
7	15-013	Rubber Bumper	2
	HNFL-14-20	Flange Lock Nut, 1/4 - 20	2
8	HW-14	Flat Washer, 1/4	4
9	20-801	Bumper Mount (BOLT TO OUTSIDE)	2
10	16-153	Elbow	1
11	42-116	Rubber Pad	1
12	15-933	Prop Strap	1
13	18-040	Hose Clamp, HS12	2
14	9032-5.5	Black Hose, 3/4	1
15	18-489	Connector, 1/2 NPT x 3/4 Barb	1
16	30-246	Rinse Nozzle	1
17	30-247	PVC Nipple	1
18	33-495	Bulkhead Fitting	1
19	16-937	Elbow, 1/2 NPT x 1/2 Barb	2
20	18-224	Hose Clamp	4
21	9050	Nylon Clear Tubing, 1/2	XX
22	18-497	Check Valve	1
23	9050-2	Nylon Clear Tubing, 1/2	1
24	20-798	Pump, 4 GPM	1
	HSM-10-32-112	Machine Screw, 10-32-1 1/8	4
	HNFL-10-32	Flange Lock Nut, 10-32	4
25	HB-14-20-075	Hex Bolt, 1/4 - 20 x 3/4	1
	HNTL-14-20	Nylon Lock Nut, 1/4 - 20	1

⚠ WARNING

This tank is for fresh clear water ONLY. Do not put chemicals in this tank.

10-417 CHEMICAL CLEAN-LOAD®

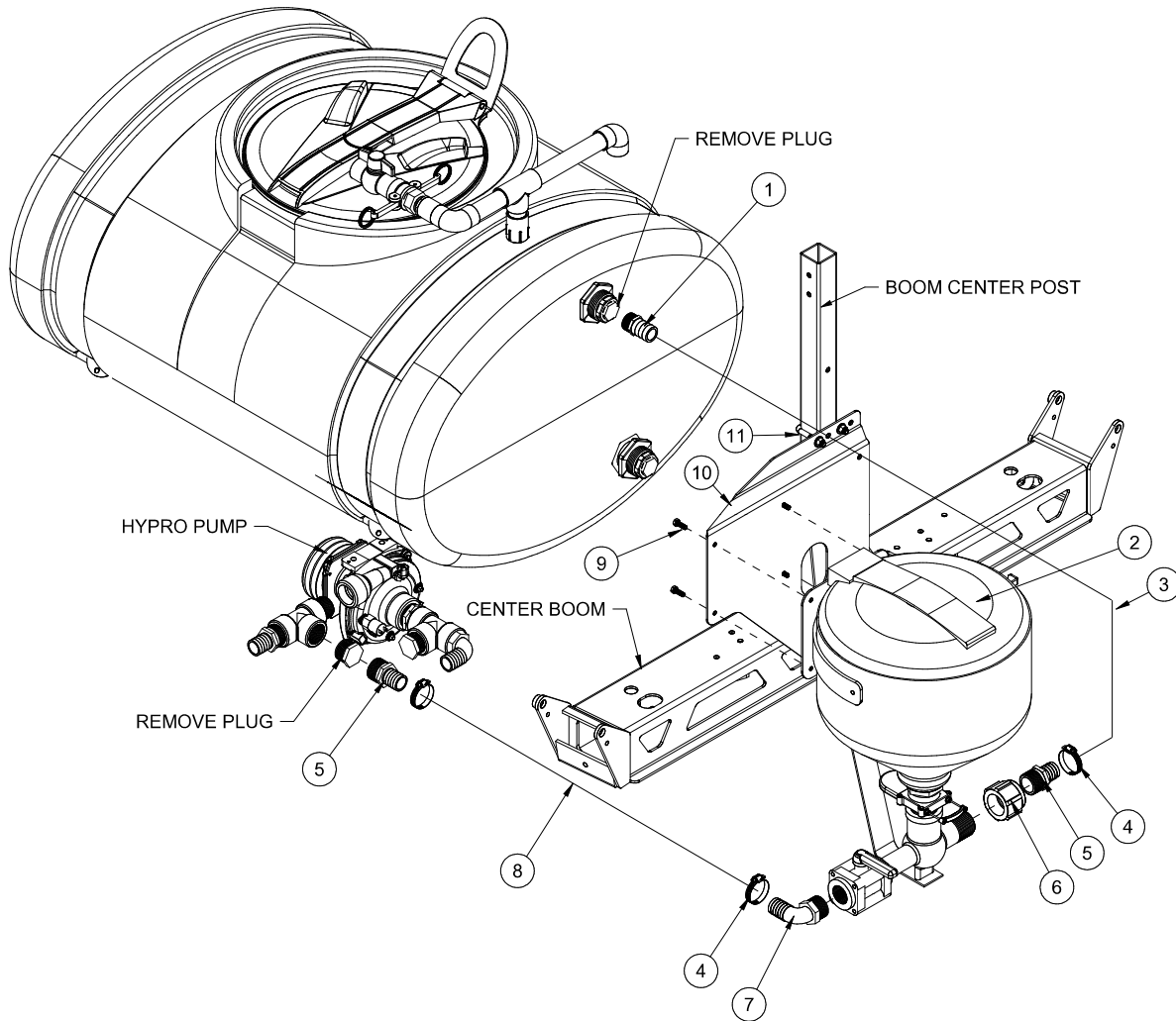

TROUBLE SHOOTING

Symptom	Corrective Action
Low education rate	<p>Check pump pressure and flow. Cleanload Educator performance is based on flow and pressure to the system. Note requirements for high education rates.</p> <p>Increase outlet hose size back to tank.</p>
Plugged or clogged bottle rinse nozzle	<p>Disassemble rotary portion of nozzle from lower valve assembly and back flush until nozzle ports are clear of debris.</p>
Plugged or clogged tank rinse nozzle	<p>Disassemble rotary portion of nozzle from NPT hose barb and back flush until nozzle ports are clear of debris. Remove screen and flush with water to clear away foreign material.</p>
Fitting leaks	<p>Check for cracks in fitting. Replace fitting if necessary.</p> <p>Disassemble and add more joint seal in compound if leak occurs on threads.</p>

10-417 CHEMICAL CLEAN-LOAD® PART LIST

REF#	PART #	DESCRIPTION	QUANTITY
1	16-159	Tank Fitting	1
2	15-620	Cleanload Eductor	1
3	8897	1¼" Hose to fitting on Back of Tank	41"
4	18-116	Hose Clamps	4
5	18-161	Fitting	2
6	18-391	Reducer Coupling	1
7	16-156	90° Hose Barb	2
8	8897	1¼" Hose to Tee by Valve	76"
9	HBFL-516-18-075	Flange Bolt, 5/16 -18 x 3/4	4
	HNFL-516-18	Flange Lock Nut, 5/16 -18	4
10	17-660	Mount Bracket SOLD SEPARATELY	1
11	17-537	Ubolt SOLD SEPARATELY	1

INSTALLATION INSTRUCTIONS

1. Make sure all chemicals have been flushed out of spray system, as you will be disconnecting fittings from the pump. Remember to use threaded tape on all new fitting connections.
2. Remove the 1¼" plug from the tee on the outlet side of the pump and install one hose barb (16-161). Then tighten so it points to the back of the machine.
3. Install mounting brackets onto left side of center boom between boom pivot and vertical boom support. Secure with 3/8 x 3 bolt, flat washer (top and bottom) and lock nut.
4. Bolt cleanload assembly onto mounting bracket using four flange bolts 5/16-18-x 3/4 and flange nuts. Install 90° hose barb fitting (16-156) into inlet side of Cleanload (valve with yellow handle). Tighten.
5. Install one reducer coupling (18-391) and one straight hose barb (16-161) onto the outlet side of Cleanload. Tighten.
6. Remove plug from top rear center of spray tank and discard. Install one hose barb (16-159) into tank fitting and tighten.
7. Route 76" hose from the hose barb on spray pump to the inlet side of the Cleanload and secure with hose clamps (18-116).
8. Route 41" hose from 90° hose barb on outlet side on Cleanload to the hose barb on the top rear of the tank.
9. Make sure all hardware, fittings, and clamps are tight. Add about 25 gallons of water to the spray tank. **CLOSE** tank lid. Start sprayer and circulate water through system and check for leaks.
10. Be sure to read start up and shutdown instructions for Cleanload assembly before using it with chemicals. When working with chemicals always wear protective clothing, goggles and gloves.

SPRAY TANK LID MUST BE CLOSED WHEN USING CLEANLOAD.

15-620 CHEMICAL CLEAN-LOAD® DRAWING

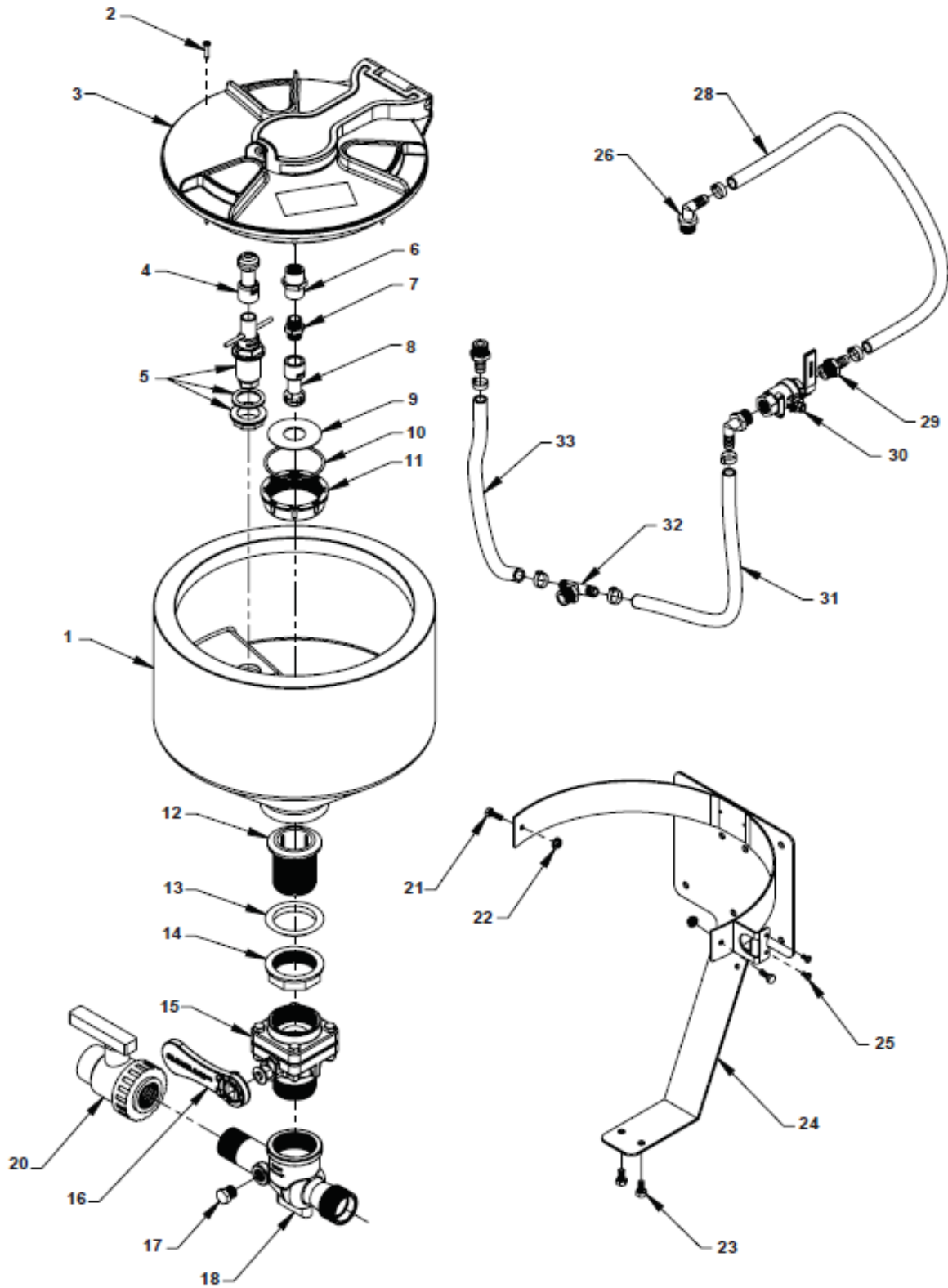

15-620 CHEMICAL CLEAN-LOAD® PARTS LIST

REF#	PART#	DESCRIPTION	QUANTITY
1	15-620-21	Tank	1
2		Screw, #6 x 1"	8
3	15-620-02	Tank Lid	1
4	15-620-22	ProClean Container Nozzle	1
5	15-620-23	ProClean Push Valve Assembly	1
	15-620-19	Tank Rinse	1
	15-620-20	Gasket, 1"	1
6		1/2 x 1/2 FNPT Coupler	1
7		1/2 x 1/2 Thread Nipple	1
8		ProClean Tank Wash Nozzle	1
9		Splash Retainer	1
10		O-ring Breather	1
11		Nut, Breather	1
12	15-620-18	Drain Head, 2"	1
13	15-620-17	Gasket: 2", Tapered	1
14	15-620-16	Locking Ring, 2"	1
15	15-620-12	Ball Valve	1
	15-620-15	Gasket: 2" BSP	1
16	15-620-13	Handle, Clean-load	1
17		1/2 MNPT PP Hex Plug	1
18	15-620-04	Clean-load Eductor	1
20	15-620-14	Ball Valve, 1 1/4 Single Union	1
21		Screw	2
22		Flange Nut	2
23		Hex Head Screw	2
24	15-620-01	Frame, Back Mount	1
25		Phillips Head Screw	2
26	15-620-11	Elbow 1/2"	2
28	15-620-08	Hose, Tank Rinse, 1/2" EPDM	1
29	15-620-09	Hose Barb 1/2 MNPT x 1/2 HB	2
30	15-620-10	Valve, SS Tank Rinse	1
31	15-620-06	Hose, Valve Feeder, 1/2" EPDM	1
32	15-620-05	Tee, 1/2 MNPT to 1/2 HB	1
33	15-620-07	Hose, Bottle Rinse, 1/2" EPDM	1

10-417 CHEMICAL CLEAN-LOAD® OPERATING INSTRUCTIONS

START-UP

1. All Clean-load valves must be closed prior to starting: inlet ball valve, knife valve and hopper rinse ball valve.
2. Open lid to check for foreign objects which may hinder performance or contaminate the system.
3. Close and lock lid by turning cover clockwise.
4. Divert pump flow to Clean-load inlet line. A pressure of 30 PSI minimum and 150 PSI maximum must be used. Highest pressures increase education rate and available wand suction.
5. Turn inlet ball valve on (yellow handle).
6. Open knife valve, located on the bottom of hopper, by pushing handle in (red handle).
7. Unlock and open lid slowly by turning cover counterclockwise.

LOADING LIQUID OR POWDERED CHEMICAL INTO HOPPER

8. Pour required amount of chemical into hopper. Avoid splashing liquids or powdered chemicals outside of hopper.
9. Rinse empty chemical containers if applicable. Place container opening over container rinse valve and press down. This will activate the rinse valve and rinse container.
10. Rinse Clean-load hopper. Close and lock lid by turning cover clockwise. Release the safety locking band on the hopper rinse ball valve and turn on for 20 seconds. Close ball valve and return locking band to locked position.
11. Open lid and inspect for chemical residue. Repeat step 10 as necessary.
12. Close knife valve by pulling red handle out towards you. Turn inlet (yellow handle) off.

LOADING LIQUID AND/OR POWDERED CHEMICAL WITH SUCTION LANCE

Note: Lance suction is dependent upon eductor pressure and flow. For best results, use highest pressure available up to 150 PSI maximum.

8. Insert lance body with o-ring into eductor until the o-ring is sealed.
9. Use the free end of the lance to pierce bag or container to vacuum powdered or liquid chemical.
10. Rinse lance. Place lance end into a clean container of water to rinse lance assembly.
11. Remove lance body from eductor and drain any remaining fluid into hopper.
12. Close knife valve (red handle). Turn inlet valve (yellow handle) off.

SHUTDOWN

1. Ensure that:
 - All valves are closed. Be sure to close knife valve first. (Close by pulling red handle out towards you.)
 - Chemical residue has been cleaned.
 - Hopper lid is closed and locked by turning cover clockwise.
2. Divert pump flow back to normal operation.

DECAL LIST

This is a list of decals located on the Spray Star 1110. Part number, description and location will help in reordering a decals.

A	10-743	Decal, Spray Star 1110
B	25-356	Decal, Tire Pressure 20psi
C	25-352	Decal, Bypass Valve
D	25-298	Decal, Warning Hot
E	15-719	Decal, Speed Control
F	27-093	Decal, Oil Level
G	25-370	Decal, 88 dba
H	15-463	Decal, Spray Pump
I	25-373	Decal, Smithco
J	10-657	Decal, Control Panel
K	25-277	Decal, Battery Warning
L	14-803	Decal, Clean Agitation Strainer
M	25-286	Decal, Pinch Point
N	27-077	Decal, Smithco round
P	51-184	Decal, Park Brake

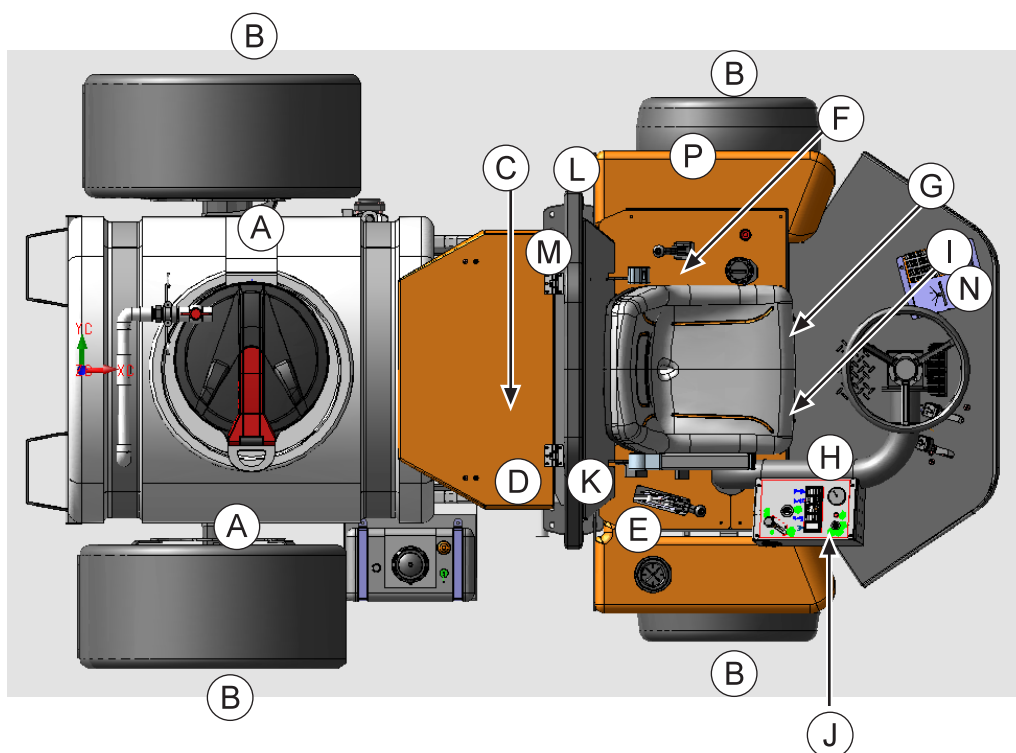

Reference

QUICK REFERENCE REPLACEMENT PARTS

REPLACEMENT FILTERS

23-031	Hydraulic Oil Filter Element 25 Micron	
13-531	Engine Oil Filter	Briggs# 842921
10-575-02	Air Filter	Briggs# 692519
10-575-03	Air Filter Pre-Cleaner	Briggs# 692520
50-403	In-Line Fuel Filter	

REPLACEMENT BELTS

10-828	V-Belt (engine to Hypro® Pump)
--------	--------------------------------

SEAL KITS

15-301	Orbital
15-301-01	Repair Kit
77-263	Hydraulic Cylinder
14-530	Seal Kit
10-510	Wheel Motor
14-080	Seal Kit
45-373	DDC20 Piston Pump
45-373-01	Overhaul Kit
15-984	Hypro® Pump
16-967	Silicone - Carbon Seal Kit

FLUIDS

Engine Oil	SAE 10W-40 API Service SJ or higher Motor Oil
Hydraulic Fluid	SAE 10W-40 API Service SJ or higher Motor Oil

OTHER PARTS

13-488	Key Switch
8-709	Key Set
14-532	Hinged Cover On Tank with Gasket
16-953-01	Lid Gasket (between lid mount and cover)
20-633	Gasket (between tank and lid mount)
16-169	Strainer Basket
15-818	#75 Fitting O-ring
15-817	#50 Fitting O-ring
Spark Plugs	Champion type RC12YC (Gap 0.030 inch (.76 mm))

The Smithco Commercial Products Two-Year Limited Warranty

Smithco, Inc. (Smithco) warrants your 2016 or newer Smithco Commercial Product (“Product”) purchased after October 1, 2016 to be free from defects in materials or workmanship for the period of time listed below. Where a warrantable condition exists, Smithco will repair the Product at no cost to you including diagnosis, labor (at the Smithco standard labor rate, subject to the Smithco flat rate schedule), and parts.

Warranty Duration is:

- (1) Two years, 1500 operational hours* from the date of delivery to the original purchaser or Five years from the date of original manufacturer of the product, whichever occurs first. (*Products equipped with hour meter).
- (2) Products used in rental situations are covered for 90 days from date of delivery to original user/renter.

Owner Responsibilities:

As the Product owner, you are responsible for required maintenance and adjustments stated in your Owner’s Manual. Failure to perform required maintenance and adjustments can be grounds for disallowing a warranty claim. **You are particularly responsible to train all present and future operators of this product on the safe operation of this product at your location.**

Instructions for Obtaining Warranty Service:

You are responsible for notifying the Authorized Smithco Products Distributor from whom you purchased the Product as soon as you believe a warrantable condition exists and not later than 30 days from discovery of the condition.

If you need help locating an Authorized Smithco Distributor, or if you have questions regarding your warranty rights or responsibilities, you may contact us at:

Smithco Product Support Department
200 West Poplar Ave.
Cameron, Wisconsin 54822
Telephone: 800-891-9435 E-Mail: ProductSupport@Smithco.com

Maintenance Parts:

Parts scheduled for replacement as required maintenance (“Maintenance Parts”), are warranted for the period of time up to the scheduled replacement time for that part.

Items/Conditions Not Covered:

Not all product failures or malfunctions that occur during the warranty period are defects in materials or workmanship. The items/conditions listed below are not covered by this warranty:



Product failures which result from the use of non-Smithco replacement parts, or from installation and use of add-on, modified, or unapproved accessories are not covered.



Product failures which result from failure to perform required maintenance and/or adjustments are not covered.



Product failures that result from operating the Product in an abusive, negligent or reckless manner are not covered.



This warranty does not apply to parts subject to consumption through use, unless found to be defective. Examples of parts which are consumed, or used up, during normal Product operation include, but are not limited to: blades, tines, teeth, scarifiers, rakes, plates, wear plates, castor wheels, tires, batteries, filters, belts, nozzles, etc.



This warranty does not apply to failures caused by outside influence. Items considered to be outside influence include, but are not limited to, weather, storage practices, contamination, use of unapproved coolants, lubricants, additives, or chemicals, etc.



This warranty does not apply to normal “wear and tear” items. Normal “Wear and Tear” includes, but is not limited to, damage to seats due to wear or abrasion, worn painted surfaces, scratched decals or windows, etc.



Smithco may require the return of failed parts or components in order to determine the validity of any warranty claim.



Smithco will not be obligated to replace components of other manufacturers if inspection by the original component manufacturer indicates that failure was due to normal wear and tear, expected consumption through use or improper care or service.

Other Legal Disclaimers:

The above remedy for product defects through repair or replacement by an authorized Smithco distributor or dealer is the purchaser’s sole remedy for any defect. This warranty gives you specific legal rights, and you may also have other rights which vary from state to state.

THERE ARE NO OTHER EXPRESS WARRANTIES OTHER THAN THOSE SET FORTH ABOVE. ALL IMPLIED WARRANTIES OF MERCHANTABILITY AND FITNESS FOR USE ARE LIMITED TO THE DURATION OF THE LIMITED WARRANTIES CONTAINED HEREIN.

Some states may not allow limitations on how long an implied warranty lasts, so the above limitation may not apply to you.

THE SMITHCO COMPANY IS NOT LIABLE FOR INDIRECT, INCIDENTAL OR CONSEQUENTIAL DAMAGES IN CONNECTION WITH THE USE OF THE PRODUCT, INCLUDING ANY COST OR EXPENSE OF PROVIDING A SUBSTITUTE PRODUCT OR SERVICE DURING PERIODS OF MALFUNCTION OR NON-USE.

Some states may not allow the exclusion of indirect, incidental or consequential damages, so the above exclusion may not apply to you.

Smithco neither assumes, nor authorizes any person to assume for it, any other liability in connection with the sale or use of this product.

