

Parts & Service
Operators



Fairway Ultra 15

Model 12-750-A

SN FWR15-213

Product Support:

Hwy 55 & Poplar Ave; Cameron WI 54822

1-800-891-9435 productsupport@smithco.com

CONTENTS

Introduction

Introduction	1-7
Introduction	1
Safe Practices	2
Safety Warnings	3
Specifications	4
Setup	5-7

Service

Service	8-11
Maintenance	8-10
Storage	11

Diagrams

Diagrams	12-15
12-750 Wiring	12-13
12-750 Hydraulics	14-15
Parts	16-31
Main Drawing	16-17
Power Box	18-19
Left Front Outboard Wing	20-21
Left Rear Wing	22-23
Right Front Outboard Wing	24-25
Right Rear Wing	26-27
Center Roller	28-29
Tank and Rear Wheels	30-31

Parts

Accessories	32-37
12-571 Foam Marker Kit	32-33
14-291 Foam Marker	34-37
Reference	38-40
Decal List	38
Declaration of Incorporation	39
Quick Reference Replacement Parts	40

Accessories

Reference

Thank you for purchasing a **Smithco** product.

Read this manual and all other manuals pertaining to the Fairway Ultra 15, FairWay Roller (FWR) carefully as they contain safety, operating, assembly and maintenance instructions. Failure to do so could result in personal injury or equipment damage.

Keep manuals in a safe place after operator and maintenance personnel have read them. Right and left sides are from the operator's seat, facing forward.

WARNING

Failure to follow cautious operating practices can result in serious injury to the operator or other persons. The owner must understand these instructions, and must allow only trained persons who understand these instructions to operate this vehicle.

All **Smithco** machines have a Serial Number and Model Number. Both numbers are needed when ordering parts.

For product and accessory information, help finding a dealer, or to register your product please contact us at www.Smithco.com.

Information needed when ordering replacement parts:

1. Model Number of machine
2. Serial Number of machine
3. Name and Part Number of part
4. Quantity of parts

For easy access record your Serial and Model numbers here.

SMITHCO			CE
WAYNE, PENNSYLVANIA 19087 USA 610-688-4009 Fax 610-688-6069			
SERIAL NO.	kW/hp	DATE OF MFG.	
<input type="text"/>	<input type="text"/>	<input type="text"/>	
MODEL NO.	lb/kg Empty	lb/kg Full	
<input type="text"/>	<input type="text"/>	<input type="text"/>	



SAFE PRACTICES

1. It is your responsibility to read this manual and all publications associated with this machine.
2. Never allow anyone to operate or service the machine or its attachments without proper training and instructions. Never allow minors to operate any equipment.
3. Learn the proper use of the machine, the location and purpose of all the controls before you operate the equipment. Working with unfamiliar equipment can lead to accidents.
4. Wear all the necessary Personal Protective Equipment (PPE) to protect our head, eyes, ears, hands and feet. Operate the machine only in daylight or in good artificial light.
5. Inspect the area where the equipment will be used. Beware of overhead obstructions and underground obstacles. Stay alert for hidden hazards.
6. Never operate equipment that is not in perfect working order or without decals, guards, shields, or other protective devices in place.
7. Never disconnect or bypass any switch.
8. Never use your hands to search for oil leaks. Hydraulic fluid under pressure can penetrate the skin and cause serious injury.
9. This machine demands your attention. To prevent loss of control or tipping of the vehicle:
 - A. Use extra caution in backing up the vehicle. Ensure area is clear.
 - B. Do not stop or start suddenly on any slope.
 - C. Reduce speed on slopes and in sharp turns. Use caution when changing directions on slopes.
 - D. Stay alert for holes in the terrain and other hidden hazards.
 - E. Operate equipment up and down slopes, never across the face.
 - F. Before unhitching, lower trailer jack.
10. Before leaving operator's position for any reason:
 - A. Disengage all drives.
 - B. Make sure all rollers are in the up position.
 - C. Shut engine off and remove the ignition key.
 - D. Turn main power switch to the off position.
11. Keep hands, feet and clothing away from moving parts. Wait for all movement to stop before you clean, adjust or service the machine.
12. Keep the area of operation clear of all bystanders.
13. Never carry passengers.
14. Use parts and materials supplied by **Smithco** only. Do not modify any function or part.
15. Avoid sharp turns. Watch the tires of the tractor while turning to make sure they do not contact the drawbar of the Fairway Roller .
16. Always drive at a safe towing speed relative to conditions and ensure that your speed is low enough for an emergency stop to be safe and secure. Smithco recommends a maximum speed of 8mph (12 kph).

These machines are intended for professional maintenance on golf courses, sports turf, and any other area maintained turf and related trails, paths and lots. No guaranty as to the suitability for any task is expressed or implied.



Read and understand this manual and all safety signs before operating and maintaining. Review the safety instructions and precautions annually.

TAKE NOTE! THIS SAFETY ALERT SYMBOL FOUND THROUGHOUT THIS MANUAL IS USED TO CALL YOUR ATTENTION TO INSTRUCTIONS INVOLVING YOUR PERSONAL SAFETY AND THE SAFETY OF OTHERS. FAILURE TO FOLLOW THESE INSTRUCTIONS CAN RESULT IN INJURY OR DEATH

Safety Alert Symbol

This symbol with a warning statement means:
**WARNING! BE ALERT!
YOUR SAFETY IS INVOLVED!**
Carefully read the message that follows

SAFETY SIGNAL WORDS

Note the use of the signal words DANGER, WARNING and CAUTION with the safety messages. The appropriate signal word for each has been selected using the following guidelines:



DANGER: Red. Indicates an imminently hazardous situation that, if not avoided, will result in death or serious injury. This signal word is to be limited to the most extreme situations typically for machine components which, for functional purposes, cannot be guarded.



WARNING: Orange. Indicates a potentially hazardous situation that, if not avoided, could result in death or serious injury, and includes hazards that are exposed when guards are removed. It may also be used to alert against unsafe practices.



CAUTION: Yellow. Indicates a potentially hazardous situation that, if not avoided, may result in minor or moderate injury. It may also be used to alert against unsafe practices.



IMPORTANT: Blue. Indicates procedures which should be followed to avoid damage to the machine.

SPECIFICATIONS FOR FAIRWAY ULTRA 15

WEIGHTS AND DIMENSIONS

Folded Width x Length 78" (1,98 m) Folded Width x 147" (3.73 m) Overall Length
 Effective Rolling Width 180" (4,57 m)
 Overall Width 185" (4,70 m)

Water Capacity 150 Gallons (567,8 l)
 Rolling Weight 3300 lbs (1496,8 kg) with 150 gallon ballast weight
 Dry Weight 2100 lbs (952,5 kg)

Tongue Weight Empty 100 lbs (45,36 kg)
 Tongue Weight Loaded 250 lbs (113 kg)

TIRES & WHEELS

Two 26.5 x 14.00 x 12 (18 psi (1.3 bar))

ROLLING GROUND PRESSURE

7 psi (.48 bar) with 150 gallons of water
 4.5 psi (.31 bar) dry weight

BATTERY (Not Included)

Deep Cycle type 24F-12 Volt
 BCI Group Size 24F
 Cold Cranking Amps 600 minimum
 Ground Terminal Polarity Negative (-)
 Maximum Length 10.25" (26 cm)
 Maximum Width 6.88" (17 cm)
 Maximum Height 10" (25 cm)

FLUID CAPACITY

Hydraulic Fluid(PN 9042) 2 Gal (7,57 liter) MileMaster 303 Tractor HYD Fluid or equivalent

TOW VEHICLE

Minimum drawbar power of 20 HP (15 kW)
 Heavy Duty Vehicle with 4 wheel brakes
 3500 lb (1587,57 kg) Towing Capacity
 40 Amp Charge Capacity



⚠ IMPORTANT

Battery not included.

1. Install an Automotive type 24F-12 Volt battery into the Power Box and secure with the battery hold-down.
2. Fill the power unit with approximately 1.50 Gal (5.68 liter) MileMaster 303 Tractor HYD Fluid or equivalent.



3. Connect hitch to tow vehicle. Adjust hitch as necessary to level roller frame. Best performance is achieved with roller frame level or hitch slightly up.
4. Install charge cable to tow vehicle battery.
 - A. Route cable to battery on the tow vehicle. Avoid exhaust, heat and moving parts.
 - B. Connect **(-)black cable** to battery ground (-).
 - C. Connect **(+) red/black short cable** to battery positive(+).

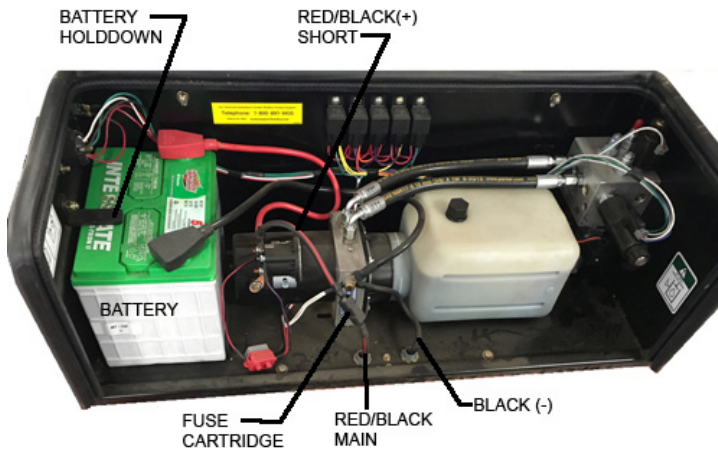

- D. Connect **(+) red/black short cable** to main cable through fuse cartridge.
 - E. Connect plugs at hitch, leaving enough cable slack for turning.
5. Fill water tank with water. Tank holds 150 gallons (567,8 l). **Tank must be full for proper operation.**
6. Connect control cord. Turn main switch off and hand switch to center position to avoid unintentional operation.

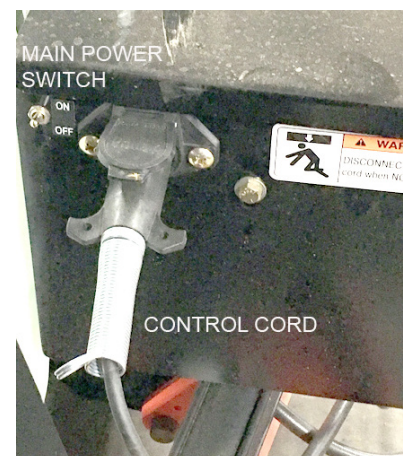

SETUP

7. Test operation - Avoid operating on hard surface.

STAND CLEAR 10' DURING ALL OPERATION

- A. Place main power switch in the "ON" position.

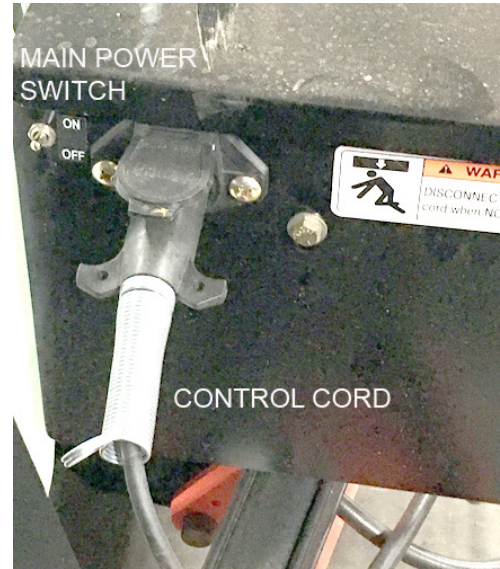

- B. Place hand switch in "LOWER" position and allow the unit to cycle completely. Unit will switch off automatically when it reaches roll pressure.



- C. Verify hitch position. Roller frame should be level or slightly 'nose up' while towing with rollers deployed. Adjust as necessary.

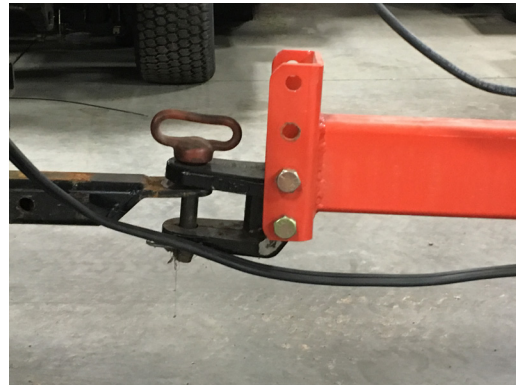

- D. Place hand switch in "LIFT" position. Rollers will stop automatically in the full position up.



Hillside Operation

Do NOT stop or start suddenly on any slope. Be especially cautious when changing direction. Do NOT operate on slopes greater than 20°.

To Level Frame.

1. Connect hitch to tow vehicle
2. Adjust hitch as necessary to level roller frame.
3. Best performance is achieved with roller frame level or hitch slightly up.

To Transport Rollers MUST be in up position.

1. Raise roller for transport by placing hand control in "LIFT" position.
2. Tow at a safe speed.

To Roll Fairways.

1. Stop tow vehicle.
2. Place hand switch in the "LOWER" position.
3. Extend outboard rollers. Wait for full deployment before towing.
4. Tow and roll at a safe speed.

Flat/Level Fairways

1. Set hand switch to the "LOWER" position.
2. Pressure will be automatically maintained.
3. Allow unit to fully deploy before towing.

Contoured/ Undulating Fairways

1. Set hand switch to the "LOWER" position
2. Allow unit to fully deploy.
3. Place hand switch to center position before towing.



MAINTENANCE

⚠ DANGER

Before servicing or making adjustments to machine, stop engine on tow vehicle and remove key from ignition.

⚠ IMPORTANT

Use all procedures and parts prescribed by the manufacturer.

Before operating this machine, become familiar with all controls and functions of this unit and the tow vehicle. Also complete all maintenance requirements and read all safety warnings. By knowing both machines thoroughly, how it operates and by doing the prescribed maintenance steps, you can expect relatively trouble-free operation for years to come.

TOW VEHICLE

You will need a heavy duty vehicle with 4 wheel brakes.

Transport Frame Assembly requires a clevis hitch and a $\frac{3}{4}$ diameter by 4" pin with some type of lock. Tow vehicle must be capable of 250 lb tongue weight.

OPERATION SAFETY

1. Before operation check to see that rollers are rotating properly.
2. When not in use, make sure rollers are in the "UP" position. Turn main power switch to the off position.

LUBRICATION

Use No. 2 General Purpose Lithium Base Grease and lubricate after the first 10 hours of use then every 100 hours thereafter. The Fairway Ultra 15 has 20 grease fittings. When inserting grease, be careful not to ruin the seal, if this happens, replace the seal at once. Be sure to wipe grease fitting clean before injecting grease. Give only one or two pumps of grease at each lubrication.

- A. One on each pillow block. (10)
- B. One on each roller shaft housing. (5)
- C. One on right and left, front and rear wing. (5)

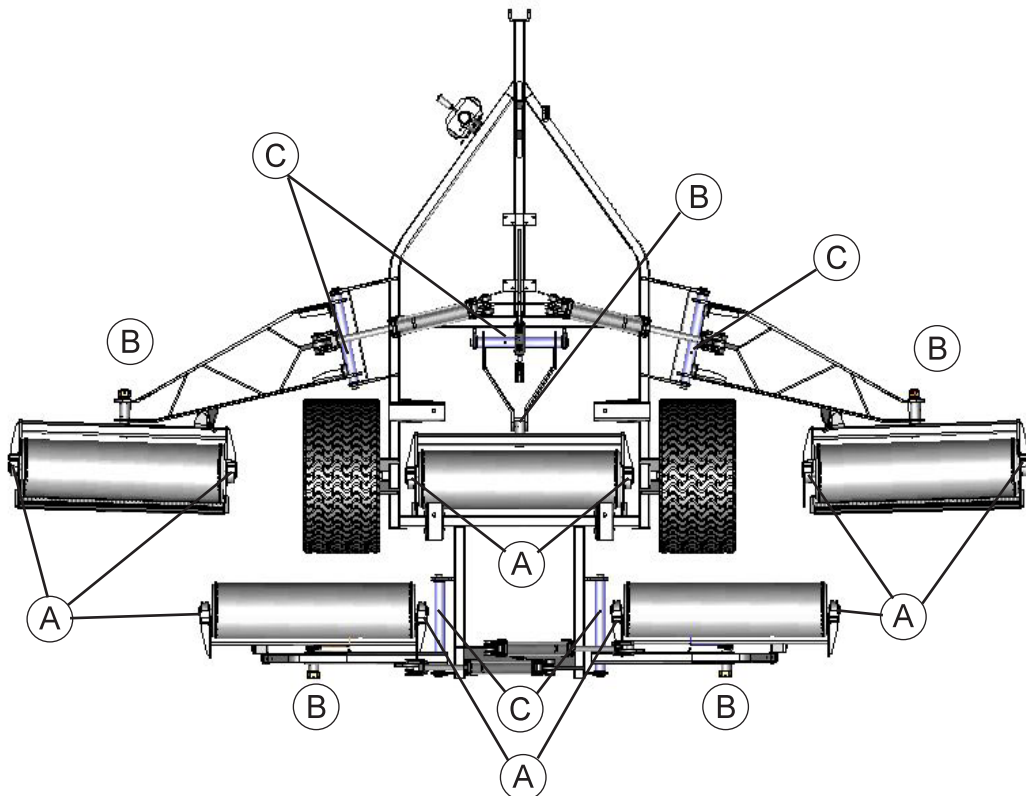

WHEEL MOUNTING PROCEDURE

1. Set park brake on tow vehicle. Turn machine off and remove key.
2. Turn off main power switch on power box.
2. Block one of the other wheels.
3. Loosen nuts slightly on wheel to be removed.
4. Lift with floor jack until wheel is off the ground.
5. Remove nuts, remove wheel.
6. Place new wheel on hub lining up bolt holes.
7. Torque nuts to 64-74 ft/lb (87-100Nm) using a cross pattern. Retorque after first 10 hours and every 200 hours thereafter.

TIRE PRESSURE

Caution must be used when inflating a low tire to recommended pressure. Over inflating can cause tires to explode. Tires on the machine should be 18 psi (1.3bar). Improper inflation will reduce tire life considerably.

DAILY CHECKLIST

1. Check engine oil level in tow vehicle. Add as needed. **DO NOT OVERFILL.**
2. Check Fairway Roller for loose or missing nuts, bolts, screws, etc., and tighten or replace as needed..
3. Check that all rollers are in good condition.
4. Grease roller and arms after the first 10 hours of operation and then every 100 hours thereafter..
5. Check hydraulic hoses for any leaks or loose connections.
6. Check tire pressure. 18 psi (1.3bar)
7. Check electrical system for loose connections or frayed wiring, including battery cables. Replace any faulty equipment or tighten if loose.
8. Fill water tank.
9. Check fluid level in power unit. Use Universal Trans-Draulic Oil.

SERVICE INTERVALS

After First 10 hours:

Check rollers for wear.

Lubricate all grease fittings

After 50 hours:

Check wheel lug nuts torque to 64-74 ft/lb (87-100Nm).

Inspect tires - Check air pressure 18 psi (1.3bar)

After 100 hours:

Lubricate all grease fittings.

After 125 hours:

Lubricate wheel bearings.

After 250 Hours:

Drain oil and fill power unit with approximately 1.50 gallons (5,7 l) Universal Trans-Draulic Oil.

Tire - Torque nuts to 64-74 ft/lb (87-100Nm) using a cross pattern.



BATTERY

Batteries normally produce explosive gases which can cause personal injury. Do not allow flames, sparks or any ignited object to come near the battery. When charging or working near battery, always shield your eyes and always provide proper ventilation.

Battery cable should be disconnected before using "Fast Charge".

Charge battery at 15 amps for 10 minutes or 7 amps for 30 minutes. Do not exceed the recommended charging rate. If electrolyte starts boiling over, decrease charging.

Always remove grounded (-) battery clamp first and replace it last. Avoid hazards by:

1. Filling batteries in well-ventilated areas.
2. Wear eye protection and rubber gloves.
3. Avoid breathing fumes when electrolyte is added.
4. Avoid spilling or dripping electrolyte.

WARNING

Battery Electrolyte is an acidic solution and should be handled with care. If electrolyte is splashed on any part of your body, flush all contact areas immediately with liberal amounts of water. Get medical attention immediately.

1. Before storing clean machine thoroughly.
2. Check bolts and nuts, tighten as necessary.
3. Make all repairs that are needed and remove any debris.
4. Store in a clean and dry area.
5. Make sure rollers are in the "UP" position.
6. Turn main power switch to the off position.
7. Disconnect control cord to prevent unintended deployment.
8. Clean and dry Remote Control Box
9. Store the Remote Control Box when not in use in the Main control Box. Storing the remote in this location will keep unintended moisture from getting into the box.

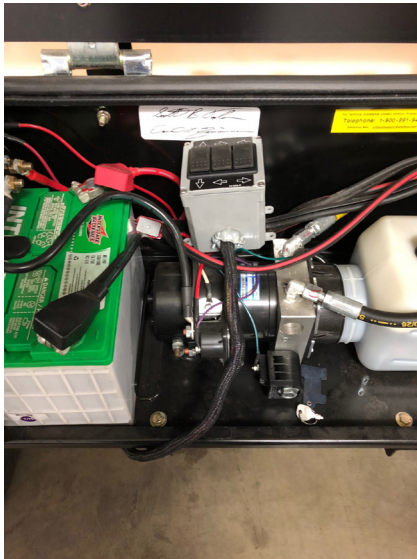

WIRING PARTS LIST

REF#	PART#	DESCRIPTION	QUANTITY
1	12-568	Toggle Switch	1
	12-792	Switch Guard	1
	12-578	Round Magnet	1
	9043	Flag Connector	3
2	12-569	Wire Cable	1
3	12-573	Male Trailer Connector	1
4	12-572	Female Trailer Connector	1
5	8975	Circuit Breaker, 30 Amp	1
	8977	Circuit Breaker Boot	1
6	30-042-06	Relay	5
7	12-585	Power Unit	1
8	18-445	Cord Connector	2
9	74-270	Parallel Battery Cable	116"
10	74-271	Power Connector	2
11	74-273	MIDI High AMP Fuse	2
	12-566	MIDI Fuse Holder	2
	74-276	#10 Ring Terminal	4
12	74-270	Parallel Battery Cable	8"
	74-272	Standard Eyelet	2
13	76-327	Battery Cable, Black	1
14		Automotive type 24F-12 Volt Battery (not included)	1
15	22-055	Battery Cable, Red	1
16	74-270	Parallel Battery Cable	168"
17	74-270	Parallel Battery Cable	8"
	74-272	Standard Eyelet	2
18	12-003	Toggle Switch	1

NS 12-574 Wire Harness, Ultra 15' Roller

- A 12-600 Manifold Block
- B Float Valve (on Manifold Block)
- C 475 PSI Down Switch (on Manifold Block)
- D 1450 PSI Up Switch (on Manifold Block)
- E Directional Valve (on Manifold Block)

HYDRAULIC DIAGRAM

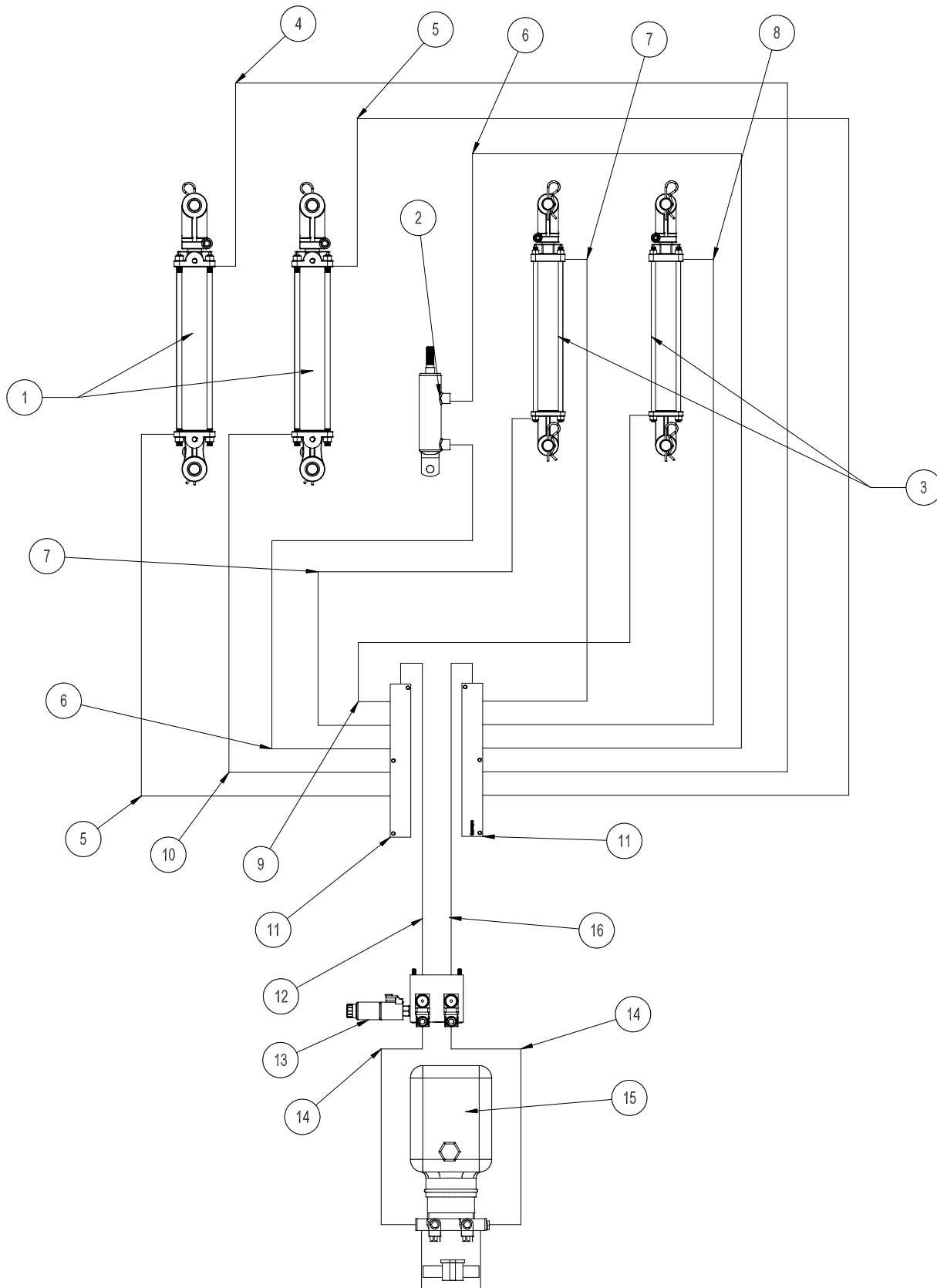

Diagrams

HYDRAULIC PARTS LIST

REF#	PART#	DESCRIPTION	QUANTITY
1	12-514	Front Hydraulic Cylinder	2
2	12-519	Center Hydraulic Cylinder	1
3	12-571	Rear Hydraulic Cylinder	2
4	12-589	Hydraulic Hose, 46"	1
5	12-593	Hydraulic Hose, 28"	2
6	12-592	Hydraulic Hose, 33"	2
7	12-586	Hydraulic Hose, 100"	2
8	12-588	Hydraulic Hose, 104.5"	1
9	12-587	Hydraulic Hose, 115"	1
10	12-591	Hydraulic Hose, 35.5"	1
11	12-584	Manifold	2
12	12-598	Hydraulic Hose, 31.5"	1
13	12-600	Manifold Block	1
14	12-594	Hydraulic Hose, 15"	2
15	12-585	Power Unit	1
16	12-590	Hydraulic Hose, 33.5"	1

Diagrams

12-750 MAIN DRAWING

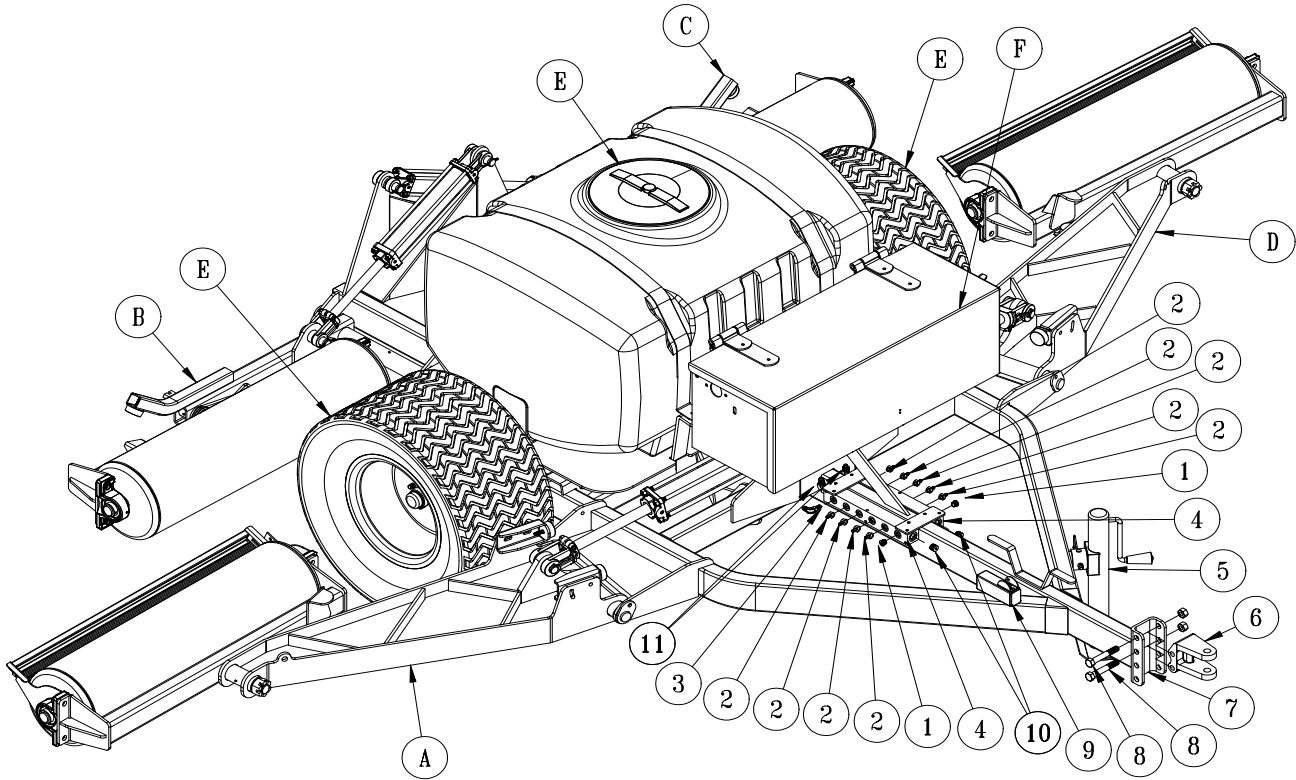

Parts

12-750 MAIN DRAWING

REF#	PART#	DESCRIPTION	QUANTITY
1	23-126	Hollow Hex Plug, #6	2
2	18-169	$\frac{3}{8}$ SAE Adapter	9
3	18-168	$\frac{3}{8}$ Straight Thread Elbow	1
4	12-584	Manifold	2
5	78-240	Trailer Jack	1
6	78-244	Adjustable $\frac{3}{4}$ " Clevis	1
7	12-760	Main Frame	1
8	HB-58-11-500	Bolt, $\frac{5}{8}$ - 11 x 5	2
	HNTL-58-11	Lock Nut, $\frac{5}{8}$ -11	2
9	12-568	Toggle Switch (Breakout on page 16)	1
	12-792	Switch Guard	1
10	18-228	Hollow Hex Plug, #8	2
11	18-185	Elbow	2

A	RH Front Outboard Wing	Page 18
B	RH Rear Wing	Page 20
C	LH Rear Wing	Page 24
D	LH Front Outboard Wing	Page 22
E	Tank and Rear Wheel	Page 28
F	Power Box	Page 16

POWER BOX DRAWING

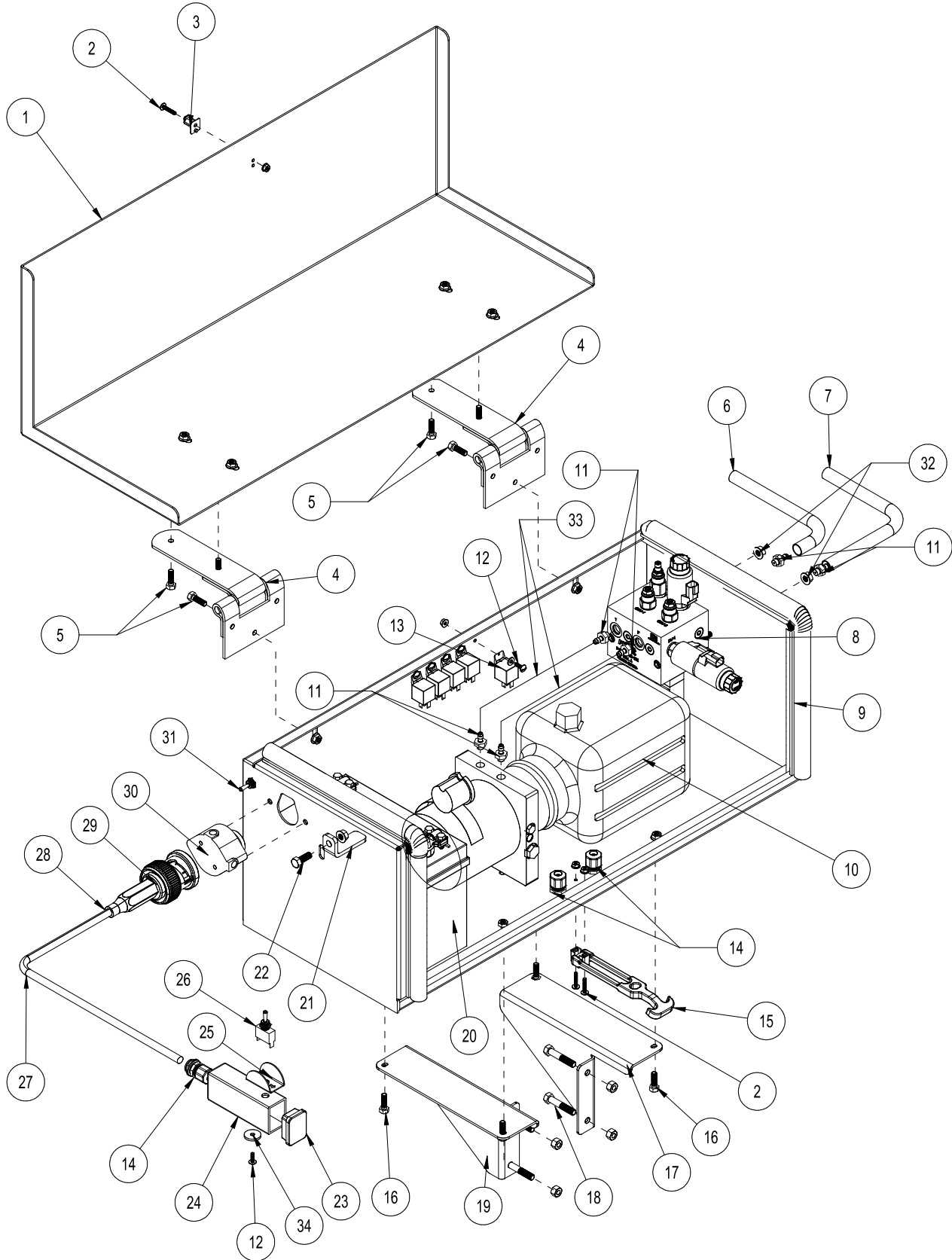

Parts

POWER BOX DRAWING

REF#	PART#	DESCRIPTION	QUANTITY
1	12-786	Power Box Cover	1
2	HSM-10-32-100	Machine Screw, #10-32 x 1	3
	HNFL-10-32	Flange Lock Nut, #10- 32	3
3*	15-437-01	Keeper	1
4	74-231	Hinge	2
5	HB-516-18-100	Bolt, $\frac{5}{16}$ -18 x 1	6
	HNFL-516-18	Flange Lock Nut, $\frac{5}{16}$ - 18	6
6	12-598	Hydraulic hose, 31.5"	1
7	12-590	Hydraulic Hose, 33.5"	1
8	12-600	Manifold Block	1
9	12-778	Power Box	1
	8947-80	Trim Seal, 80"	1
10	12-585	Power Unit	1
	9042	Hydraulic Fluid	2 GAL
11	18-169	$\frac{3}{8}$ SAE Adapter	6
12	HSM-10-32-063	Machine Screw, #10 -32 x $\frac{5}{8}$	6
	HW-10	Washer, #10	5
	HNFL-10-32	Flange Lock Nut, #10-32	6
13	30-042-06	Relay	5
14	18-445	Cord Connector	3
15*	15-437-02	Handle and Bracket	1
16	HB-14-20-075	Bolt, $\frac{1}{4}$ - 20 x $\frac{3}{4}$	4
	HW-14	Washer, $\frac{1}{4}$	4
	HNFL-14-2	Flange Lock Nut, $\frac{1}{4}$ -20	4
17	12-771	LH Power unit Mount	1
18	HB-38-16-200	Bolt, $\frac{3}{8}$ - 16 x 2	4
	HNTL-38-16	Lock Nut, $\frac{3}{8}$ - 16	4
19	12-772	RH Power Unit Mount	1
20		Battery - Automotive type 24F-12 Volt (Not Included)	1
	76-327	Battery Cable, Negative	1
	22-055	Battery Cable, Positive	1
21	74-234	Battery Hold Down	1
22	HB-38-16-100	Bolt, $\frac{3}{8}$ - 16 x 1	1
	HNTL-38-16	Lock Nut, $\frac{3}{8}$ - 16	1
23	12-575	Rectangular Cap	1
24	12-790	Switch Handle	1
25	12-792	Switch Guard	1
26	12-568	Toggle Switch	1
27	12-569	4-Wire Cable	1
28	12-577	Trailer Connector Guard	1
29	12-573	Male Trailer Connector	1
30	12-572	Female Trailer Connector	1
31	12-003	Toggle Switch	1
32	HNFL-38-16	Flange Lock Nut, $\frac{3}{8}$ - 16	2
33	12-594	Hydraulic Hose, 15"	2
34	12-578	Magnet	1
*	15-437	Latch, Complete	1

LEFT FRONT OUTBOARD WING

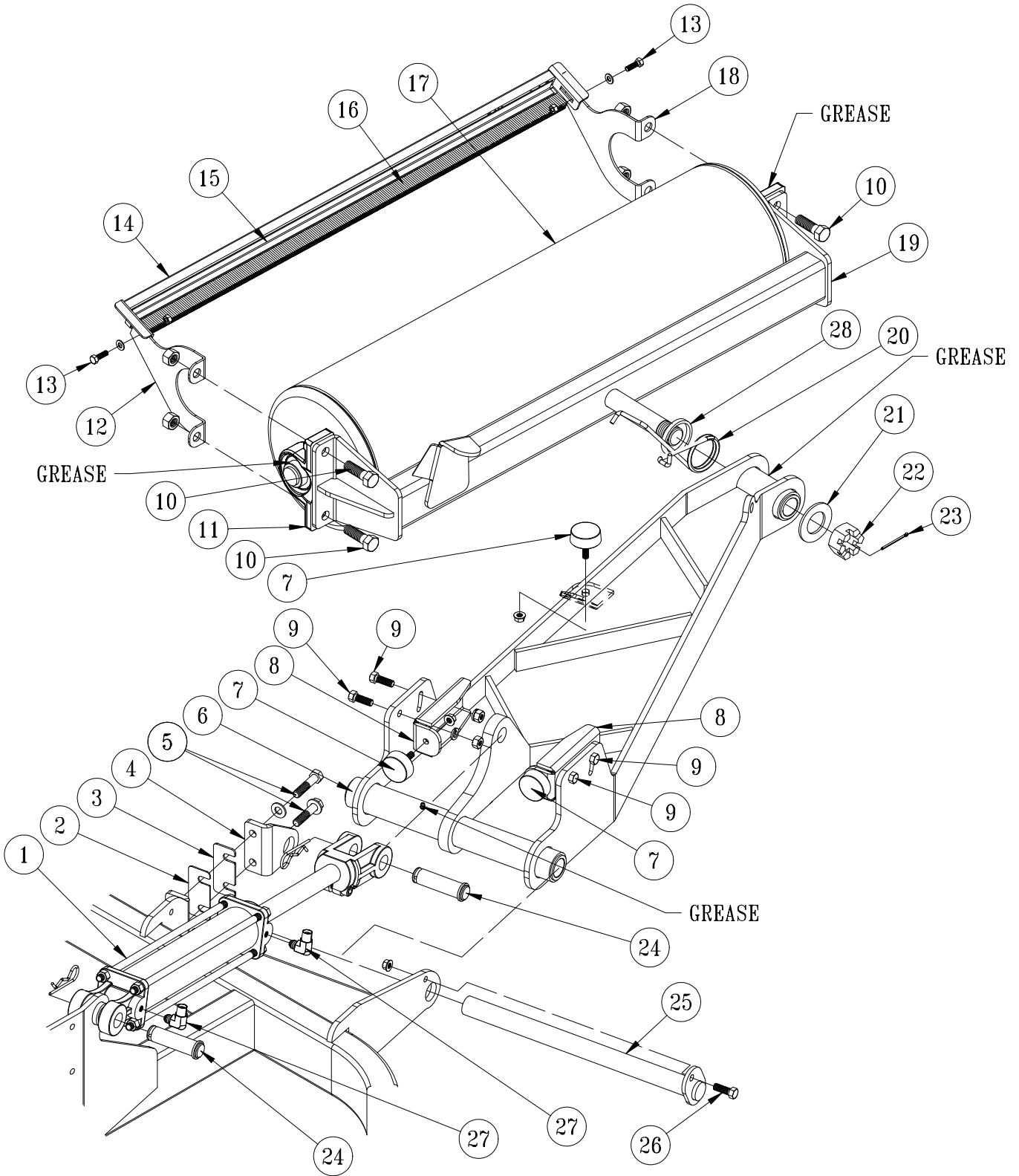

Parts

LEFT FRONT OUTBOARD WING

REF#	PART#	DESCRIPTION	QUANTITY
1	12-514	Hydraulic Cylinder (* comes with clevis pins)	1
2	12-802	Hinge Shim-14GA	1+
3	12-803	Hinge Shim-12GA	1+
4	12-800	LH Hinge Bracket	1
5	HB-12-13-225	Bolt, 1/2 - 13 x 2 1/4	2
	HNTL-12-13	Lock Nut, 1/2 - 13	2
	HW-12	Washer, 1/2	2
6	12-784	LH Outboard Wing	1
	18-153	Bushing	4
	HG-14-28-180	Grease Fitting, 1/4 - 28 x 180°	2
7	50-081	Rubber Bumper	3
	HNFL-38-16	Flange Lock Nut, 3/8- 16	3
8	12-791	Outboard Wing Limit	2
9	HB-716-14-125	Bolt, 7/16 - 14 x 1 1/4	4
	HWL-716	Lock Washer, 7/16	4
	HN-716-14	Nut, 7/16 - 14	4
10	HB-58-11-200	Bolt, 5/8 - 11 x 2	4
	HNTL-58-11	Lock Nut, 5/8 - 11	4
11	75-511	Pillow Block	2
	HG-14-28-180	Grease Fitting, 1/4 - 28 x 180°	2
12	12-774	RH Brush Mount	1
13	HB-516-18-100	Bolt, 5/16 - 18 x 1	2
	HW-516	Washer, 5/16	2
	HNFL-516-18	Flange Lock Nut, 5/16 - 18	2
14	12-789	Brush Mount	1
15	12-798	Strip Brush Holder	1
	18-153	Bushing	1
	HRS-316-025	Rivet, 3/16 x 1/4	5
16	12-599	Strip Brush	1
17	12-788	Roller	1
18	12-773	LH Brush Mount	1
19	12-785	LH Outboard Roller Mount	1
20	12-796	Torsion Spring, LH Front	1
21	HMB-114-14	Machine Bushing, 1/4 x 14GA	1
22	HNA-114-12	Axle Nut, 1 1/4 - 12	1
23	HP-18-200	Cotter Pin, 1/8 x 2	1
24*	HCP-100-325	Clevis Pin, 1 x 3 1/4	2
	HHP-.177	Bridge Pin, .177 x 3 3/4	2
25	12-797	Pivot Shaft	1
26	HB-38-16-100	Bolt, 3/8 - 16 x 1	1
	HNTL-38-16	Lock Nut, 3/8 - 16	1
27	23-167	Male Elbow	2
28	12-765	Spring Spacer	1

LEFT REAR WING

Parts

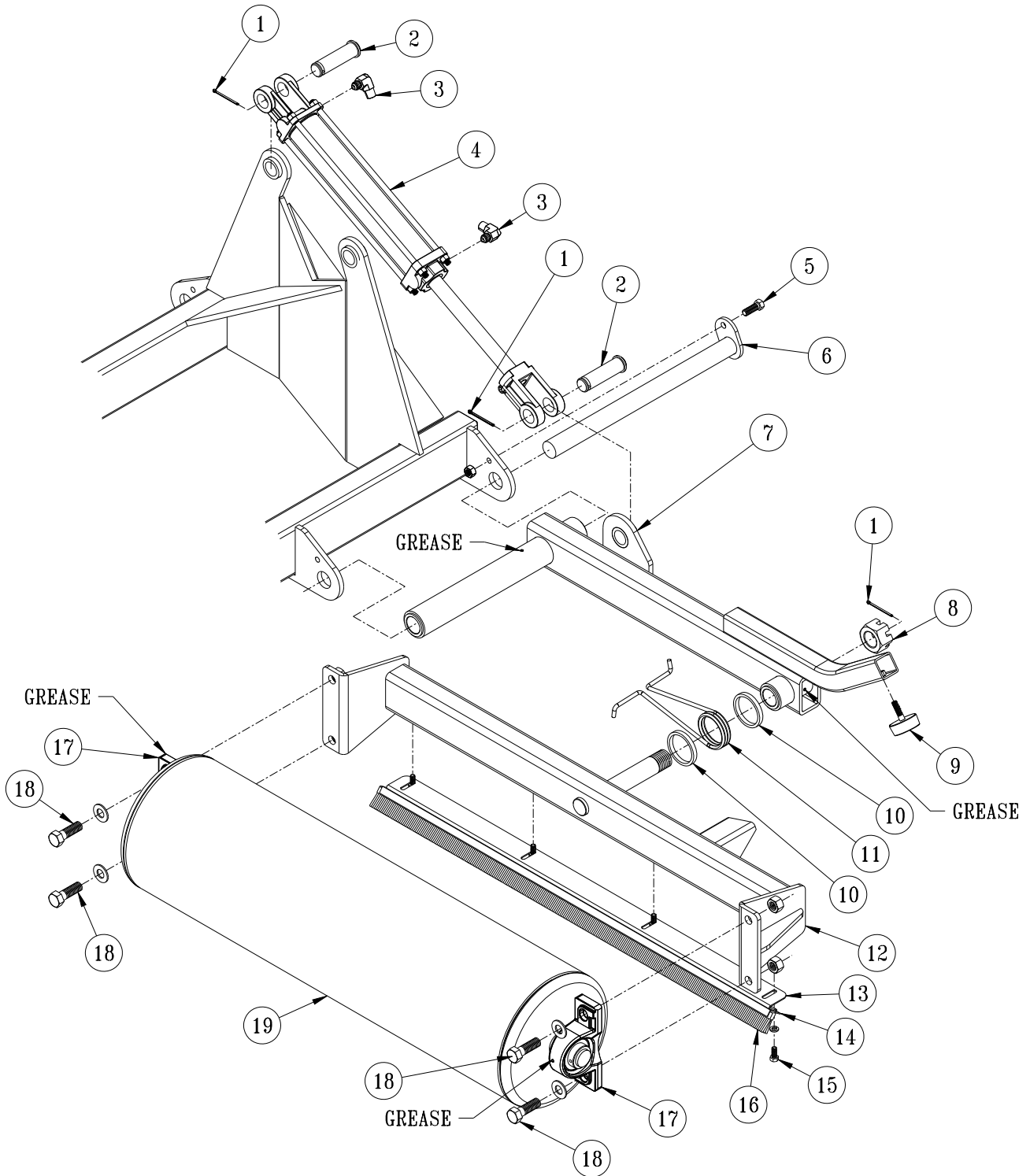

LEFT REAR WING

REF#	PART#	DESCRIPTION	QUANTITY
1	HP-18-200	Cotter Pin, 1/8 x 2	3
2*	HCP-100-325	Clevis Pin, 1 x 3 1/4	2
3	23-167	Male Elbow	2
4	12-571	Hydraulic Cylinder (* comes with clevis pins)	1
5	HB-38-16-100	Bolt, 3/8 - 16 x 1	1
	HNTL-38-16	Lock Nut, 3/8 -16	1
6	12-797	Pivot Shaft	1
7	12-762	Left Rear Wing	1
	18-153	Bushing	4
	HG-14-28-180	Grease Fitting, 1/4 - 28 x 180°	2
8	HNA-114-12	Axle Nut, 1 1/4 - 12	1
9	50-081	Rubber Bumper	1
	HNFL-38-16	Flange Lock Nut, 3/8- 16	1
10	12-765	Spring Spacer	2
11	12-794	Torsion Spring, LH Rear	1
12	12-766	LH Rear Roller Frame	1
13	12-775	Brush Bracket	1
14	12-798	Strip Brush Holder	1
	HRS-316-025	Rivet, 3/16 x 1/4	5
15	HB-38-16-100	Bolt, 3/8 - 16 x 1	4
	HW-38	Washer, 3/8	4
16	12-599	Strip Brush	1
17	75-511	Pillow Block	2
	HG-14-28-180	Grease Fitting, 1/4 - 28 x 180°	2
18	HB-58-11-200	Bolt, 5/8 -11 x 2	4
	HW-58	Washer, 5/8	4
	HNTL-58-11	Lock Nut, 5/8 - 11	4
19	12-788	Roller	1

RIGHT FRONT OUTBOARD WING

Parts

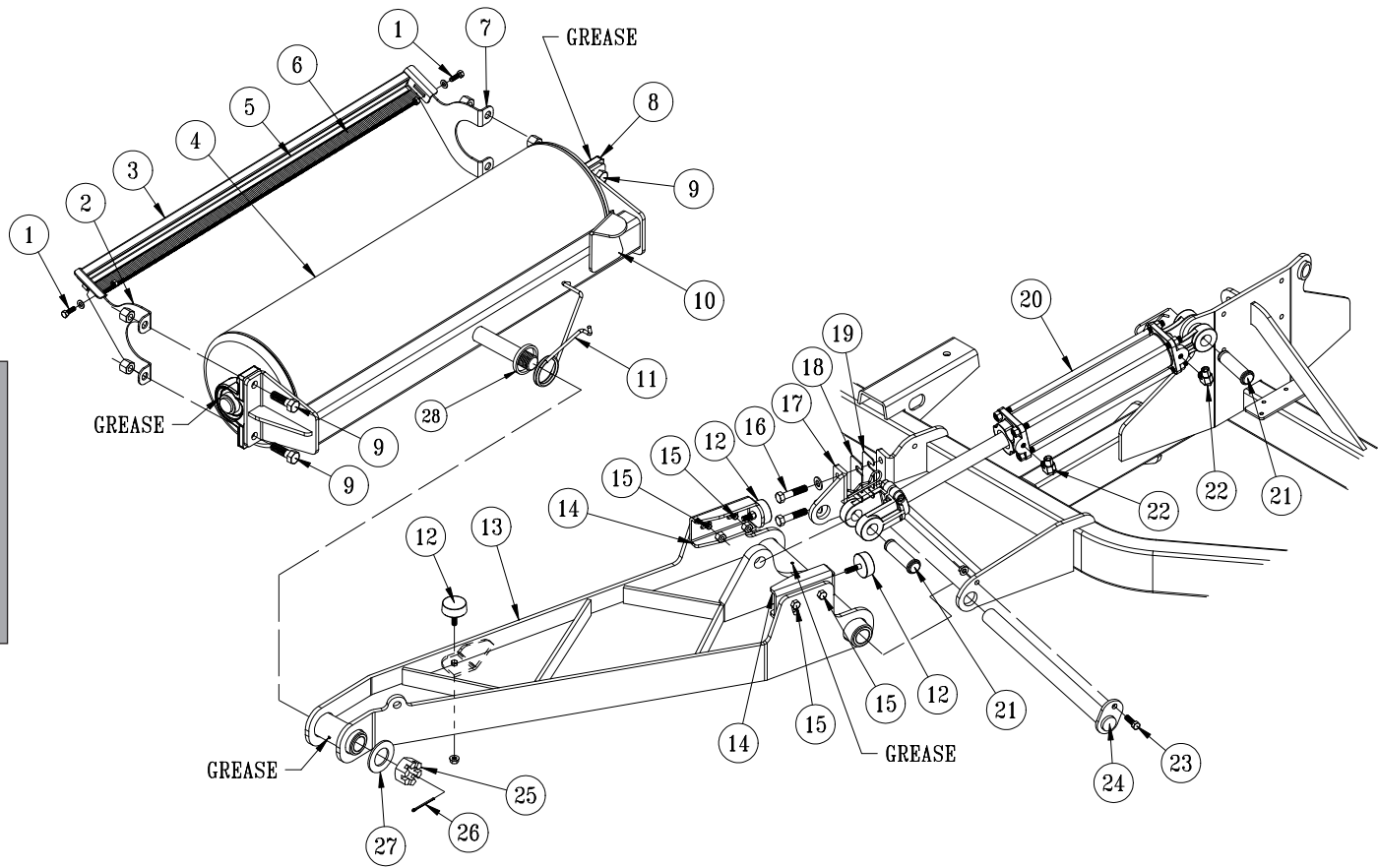

RIGHT FRONT OUTBOARD WING

REF#	PART#	DESCRIPTION	QUANTITY
1	HB-516-18-100	Bolt, $\frac{5}{16}$ - 18 x 1	2
	HW-516	Washer, $\frac{5}{16}$	2
	HNFL-516-18	Flange Lock Nut, $\frac{5}{16}$ - 18	2
2	12-774	RH Brush Mount	1
3	12-789	Brush Mount	1
4	12-788	Roller	1
5	12-798	Strip Brush Holder	1
	HRS-316-025	Rivet, $\frac{3}{16}$ x $\frac{1}{4}$	5
6	12-599	Strip Brush	1
7	12-773	LH Brush Mount	1
8	75-511	Pillow Block	2
	HG-14-28-180	Grease Fitting, $\frac{1}{4}$ - 28 x 180°	2
9	HB-58-11-200	Bolt, $\frac{5}{8}$ -11 x 2	4
	HNTL-58-11	Lock Nut, $\frac{5}{8}$ - 11	4
10	12-776	RH Outboard Roller Mount	1
11	12-795	Torsion Spring, RH Front	1
12	50-081	Rubber Bumper	3
	HNFL-38-16	Flange Lock Nut, $\frac{3}{8}$ - 16	3
13	12-767	RH Outboard Wing	1
	18-153	Bushig	4
	HG-14-28-180	Grease Fitting, $\frac{1}{4}$ - 28 x 180°	2
14	12-791	Outboard Wing Limit	2
15	HB-716-14-125	Bolt, $\frac{7}{16}$ -14 x $1\frac{1}{4}$	4
	HWL-716	Lock Washer, $\frac{7}{16}$	4
	HN-716-14	Nut, $\frac{7}{16}$ - 14	4
16	HB-12-13-225	Bolt, $\frac{1}{2}$ -13 x $2\frac{1}{4}$	2
	HNTL-12-13	Lock Nut, $\frac{1}{2}$ - 13	2
	HW-12	Washer, $\frac{1}{2}$	2
17	12-801	RH Hinge Bracket	1
18	12-803	Hinge Shim-12GA	1+
19	12-802	Hinge Shim-14GA	1+
20	12-514	Hydraulic Cylinder (* comes with clevis pins)	1
21*	HCP-100-325	Clevis Pin, 1 x $3\frac{1}{4}$	2
	HHP-.177	Bridge Pin, .177 x $3\frac{3}{4}$	2
22	23-167	Male Elbow	2
23	HB-38-16-100	Bolt, $\frac{3}{8}$ - 16 x 1	1
	HNTL-38-16	Lock Nut, $\frac{3}{8}$ -16	1
24	12-797	Pivot Shaft	1
25	HNA-114-12	Axle Nut, $1\frac{1}{4}$ - 12	1
26	HP-18-200	Cotter Pin, $\frac{1}{8}$ x 2	1
27	HMB-114-14	Machine Bushing, $1\frac{1}{4}$ x 14GA	1
28	12-765	Spring Spacer	1

RIGHT REAR WING

PARTS

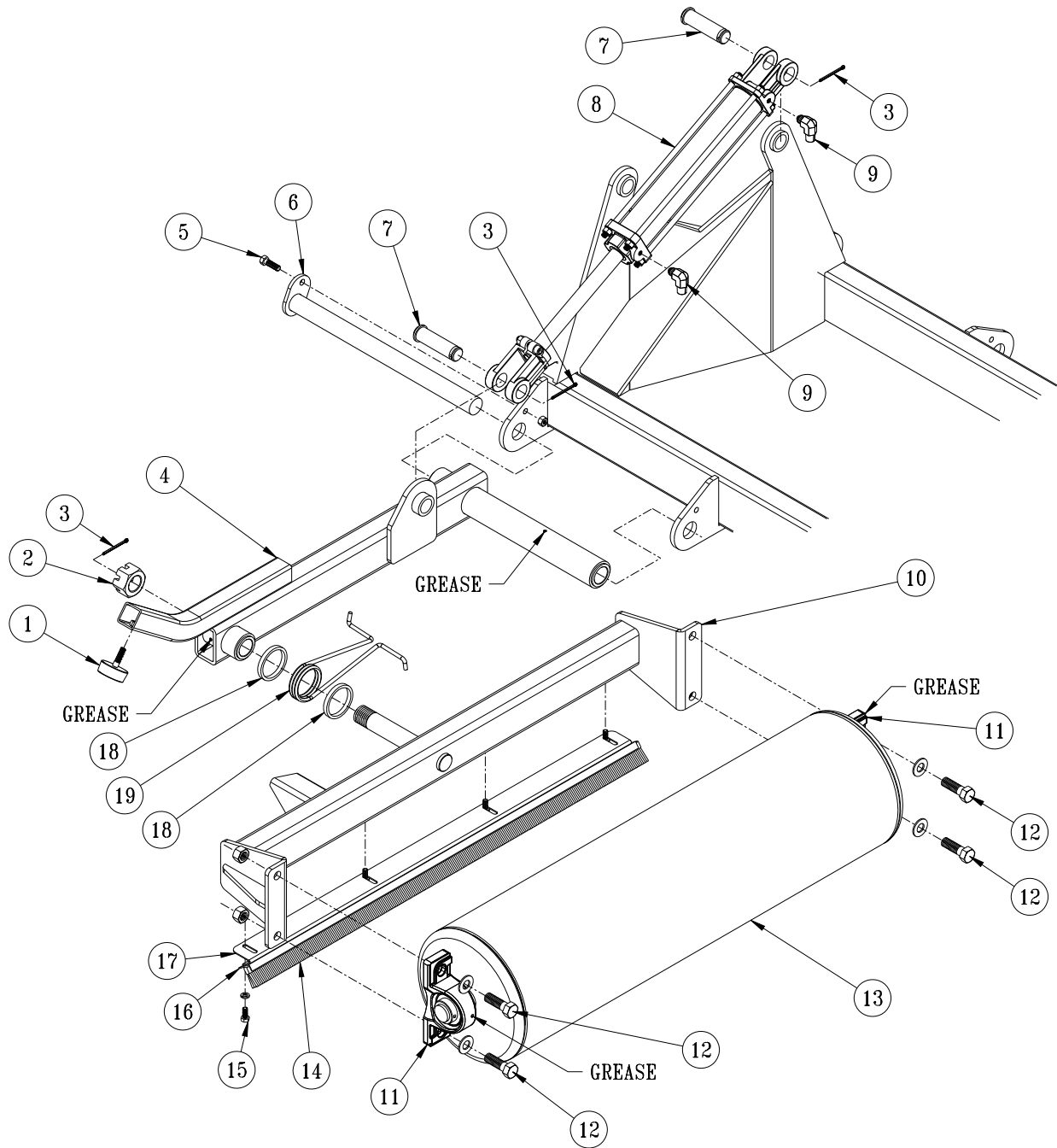

RIGHT REAR WING

REF#	PART#	DESCRIPTION	QUANTITY
1	50-081	Rubber Bumper	1
	HNFL-38-16	Flange Lock Nut, $\frac{3}{8}$ - 16	1
2	HNA-114-12	Axle Nut, $1\frac{1}{4}$ - 12	1
3	HP-18-200	Cotter Pin, $\frac{1}{8}$ x 2	3
4	12-763	Right Rear Wing	1
	18-153	Bushing	4
	HG-14-28-180	Grease Fitting, $\frac{1}{4}$ - 28 x 180°	2
5	HB-38-16-100	Bolt, $\frac{3}{8}$ - 16 x 1	1
	HNTL-38-16	Lock Nut, $\frac{3}{8}$ -16	1
6	12-797	Pivot Shaft	1
7*	HCP-100-325	Clevis Pin, 1 x $3\frac{1}{4}$	2
8	12-571	Hydraulic Cylinder (* comes with clevis pins)	1
9	23-167	Male Elbow	2
10	12-777	RH Rear Roller Frame	1
11	75-511	Pillow Block	2
	HG-14-28-180	Grease Fitting, $\frac{1}{4}$ - 28 x 180°	2
12	HB-58-11-200	Bolt, $\frac{5}{8}$ -11 x 2	4
	HW-58	Washer, $\frac{5}{8}$	4
	HNTL-58-11	Lock Nut, $\frac{5}{8}$ - 11	4
13	12-788	Roller	1
14	12-599	Strip Brush	1
15	HB-38-16-100	Bolt, $\frac{3}{8}$ - 16 x 1	4
	HW-38	Washer, $\frac{3}{8}$	4
16	12-798	Strip Brush Holder	1
	HRS-316-025	Rivet, $\frac{3}{16}$ x $\frac{1}{4}$	5
17	12-775	Brush Bracket	1
18	12-765	Spring Spacer	2
19	12-793	Torsion Spring, Right Rear	1

CENTER ROLLER

PARTS

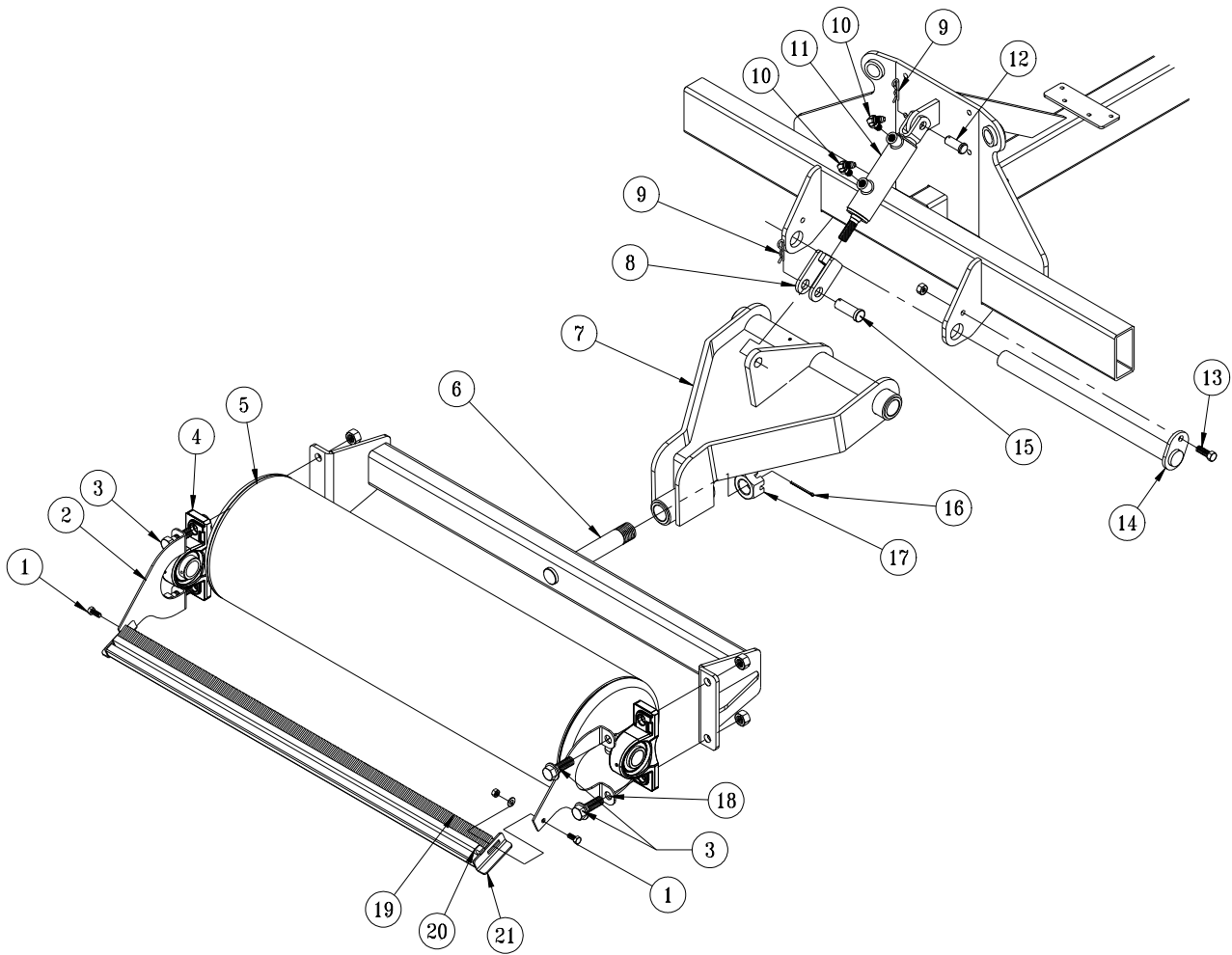

CENTER ROLLER

REF#	PART#	DESCRIPTION	QUANTITY
1	HB-516-18-100	Bolt, $\frac{5}{16}$ - 18 x 1	2
	HW-516	Washer, $\frac{5}{16}$	2
	HNFL-516-18	Flange Lock Nut, $\frac{5}{16}$ - 18	2
2	12-774	RH Brush Mount	1
3	HB-58-11-200	Bolt, $\frac{5}{8}$ - 11 x 2	4
	HNTL-58-11	Lock Nut, $\frac{5}{8}$ - 11	4
4	75-511	Pillow Block	2
	HG-14-28-180	Grease Fitting, $\frac{1}{4}$ - 28 x 180°	2
5	12-788	Roller	1
6	12-787	Center Roller Mount	1
7	12-761	Center Lift	1
	18-153	Bushing	4
	HG-14-28-180	Grease Fitting, $\frac{1}{4}$ - 28 x 180°	2
8	12-783	Cylinder Extension	1
9	HHP-18	Bridge Pin, $\frac{1}{8}$	2
10	18-168	$\frac{3}{8}$ - 90° Elbow	2
11	12-519	Hydraulic Cylinder	1
12	HCP-34-200	Clevis Pin, $\frac{5}{8}$ x 1-1/2	1
13	HB-38-16-100	Bolt, $\frac{3}{8}$ - 16 x 1	1
	HNTL-38-16	Lock Nut, $\frac{3}{8}$ - 16	1
14	12-797	Pivot Shaft	1
15	HCP-34-200	Clevis Pin, $\frac{3}{4}$ x 2	1
16	HP-18-200	Cotter Pin, $\frac{1}{8}$ x 2	1
17	HNA-114-12	Axle Nut, $1\frac{1}{4}$ - 12	1
18	12-773	LH Brush Mount	1
19	12-599	Strip Brush	1
20	12-798	Strip Brush Holder	1
	HRS-316-025	Rivet, $\frac{3}{16}$ x $\frac{1}{4}$	5
21	12-789	Brush Mount	1

TANK AND REAR WHEELS

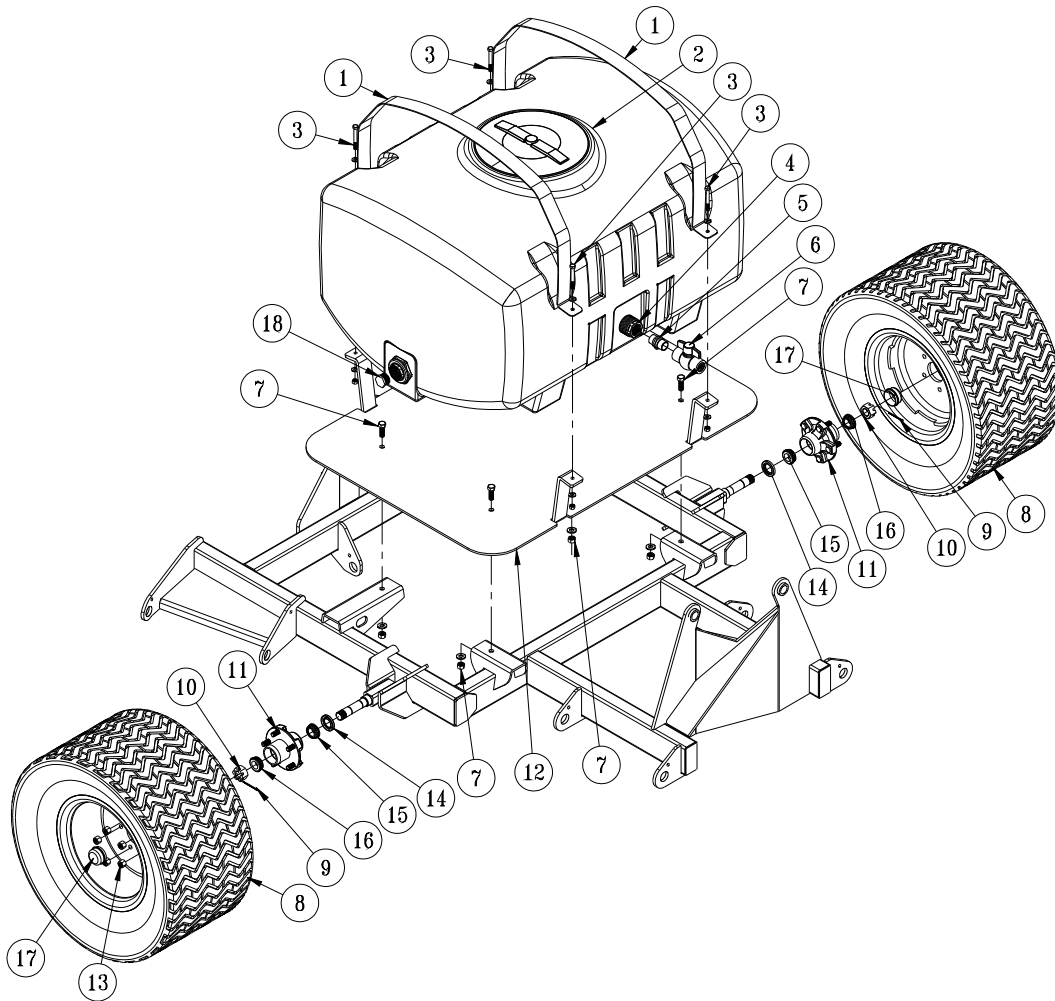

Parts

TANK AND REAR WHEELS

REF#	PART#	DESCRIPTION	QUANTITY
1	12-770	Tank Strap	2
2	12-576	150 Gallon Tank	1
3	HB-38-16-225	Bolt, $\frac{3}{8}$ -16 x 2 $\frac{1}{4}$	4
	HW-38	Washer, $\frac{3}{8}$	4
	HNTL-38-16	Lock Nut, $\frac{3}{8}$ -16	4
4	16-945	1" Double Thread Fitting	1
5	16-851	1" Nylon Close Nipple	1
6	18-448	1" PVC Ball Valve	1
7	HB-12-13-150	Bolt, $\frac{1}{2}$ -13 x 1 $\frac{1}{2}$	4
	HW-12	Washer, $\frac{1}{2}$	4
	HNTL-12-13	Lock Nut, $\frac{1}{2}$ -13	4
8	72-042	Tire and Wheel	2
	33-072-01	Tire, 26.5 x 14.00 x 12	2
	72-042-02	Wheel, 12 x 10.5	2
9	HP-18-200	Cotter Pin, $\frac{1}{8}$ x 2	2
10	HNAR-100-14	Axle Nut, 1 - 14	2
11	33-073	Hub Assembly, 3500# (includes * items)	2
12	12-764	Tank Base	1
13*	HNL-12-20	Lug Nut, $\frac{1}{2}$ - 20	10
14*	33-073-01	Seal	2
15*	78-118	Inner Bearing	2
16*	78-119	Outer Bearing	2
17*	33-073-02	Dust Cap	2
18	16-162	Plug	1
*	15-505-02	Intake Exhaust Valve Sub Assembly	
†	15-505-04	Intake Piston Sub Assembly	

12-751 FOAM MARKER KIT

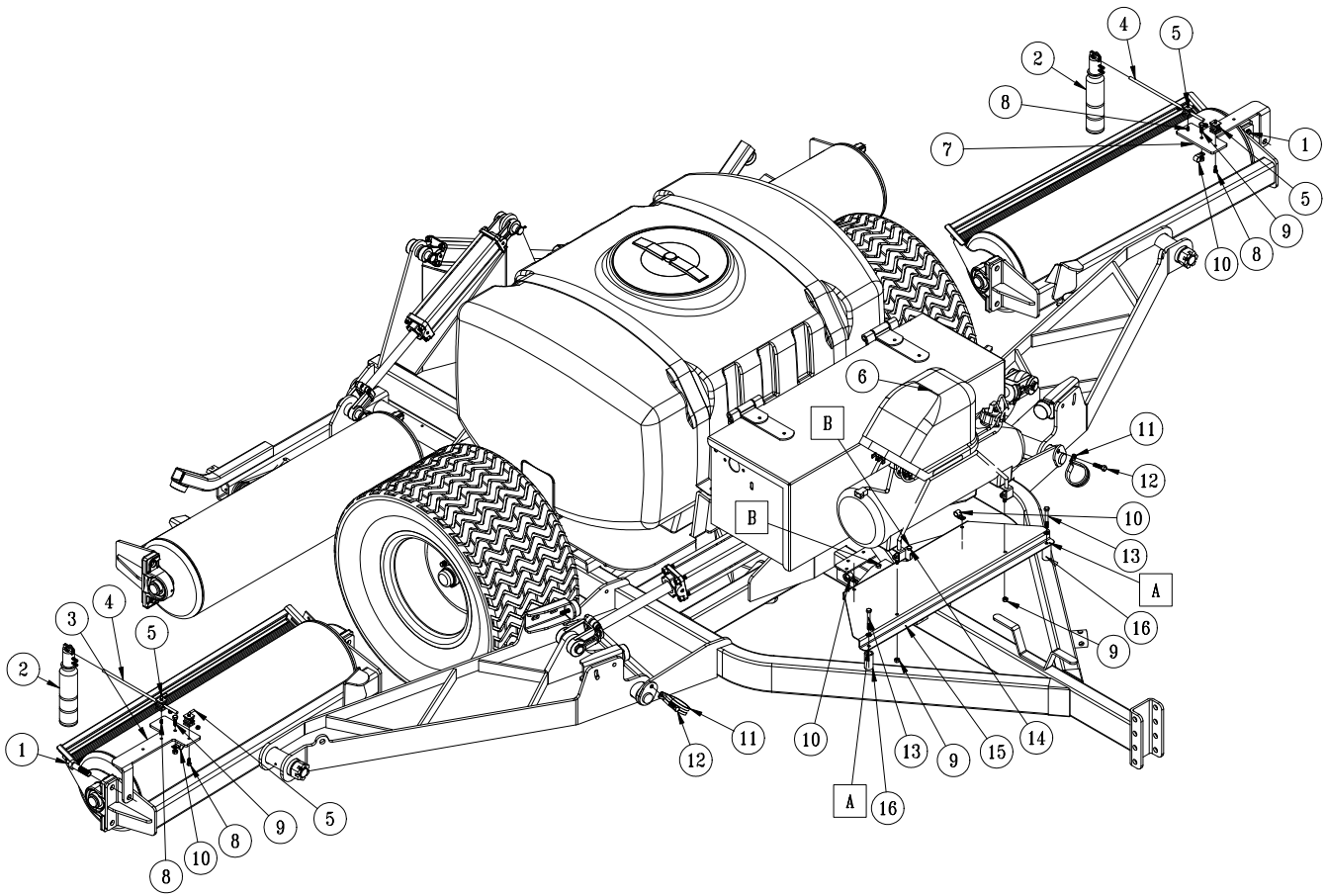

FOAM MARKER WIRING DRAWING

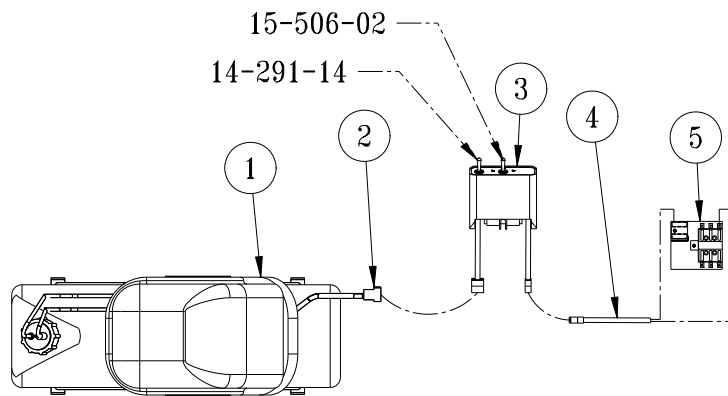

12-751 FOAM MARKER KIT

REF#	PART#	DESCRIPTION	QUANTITY
1	HB-58-11-250	Hex Bolt, $\frac{5}{8}$ - 11 x 2 $\frac{1}{2}$	2
2	15-511	Foam Nozzle	2
3	12-604	RH Nozzle Mount	1
4	15-510-01	Nozzle Mount Rod	2
5	16-987	Foam Nozzle Mounting Kit	2
6	14-291	Foamer	1
	14-291-04	Tank Bracket	2
	14-284-02	Cap Assembly	1
		Blue Tube	1
		Clear Tube	1
	14-291-03	Compressor Only	1
	14-291-01	Black Cover	1
	14-291-02	Foamer Tank	1
	14-291-05	Double Switch Box	1
	15-506-01	Fuse (F10A 250)	1
	15-506-02	Switch	1
7	12-605	LH Nozzle Mount	1
8	HBM-6-1-16	Metric Hex Bolt, M6-1 x 16	4
	HNM-6-1	Metric Hex Nut, M6-1	4
9	HB-516-18-100	Hex Bolt, $\frac{5}{16}$ - 18 x 1	6
	HNFL-516-18	Flange Lock Nut, $\frac{5}{16}$ - 18	6
10	8-731	J-Clamp, Coated	4
11	HLC-A-200	Loom Clamp, Coated	2
12	HB-38-16-125	Hex Bolt, $\frac{3}{8}$ - 16 x 1 $\frac{1}{4}$	2
13	HB-516-18-250	Hex Bolt, $\frac{5}{16}$ - 18 x 2 $\frac{1}{2}$	2
	HWL-516	Lock Washer, $\frac{5}{16}$	2
14	HB-14-20-250	Hex Bolt, $\frac{1}{4}$ - 20 x 1	2
	HNFL-14-20	Flange Lock Nut, $\frac{1}{4}$ - 20	2
15	12-603	Tank Mount	1
16	60-406	Spacer	2

FOAM MARKER WIRING PARTS LIST

REF#	PART#	DESCRIPTION	QUANTITY
1	14-291-03	Compressor	1
2	15-504-04	Wiring Harness	1
3	14-291-05	Switch Box	1
	33-508	Auto Blade Type Fuse 15 amp	1
	15-506-02	Switch - middle	1
	14-291-14	Switch - outside	1
4	15-509	Power Cable	1
5	33-271	Fuse Block (part of machine)	1
	33-508	Auto Blade Type Fuse 15 amp	1

14-291 FOAM MARKER DRAWING



REF#	PART#	DESCRIPTION	QUANTITY
1	15-507	Foamer Tubing	2
2	14-291-02	Tank	1
3	14-291-01	Black Cover	1
	14-536	Compressor Complete	1
4	14-284-02	Cap Assembly	1
5	14-291-04	Tank Bracket	2
6	14-291-05	Switch Box	1
7	15-511	Foam Nozzle	2
8	15-510-01	Nozzle Mounting Rod	2
9	16-987	Foam Nozzle Mounting Kit	1
10	14-284-05	Extension Wire	1

15-505 MOTOR SUB ASSEMBLY DRAWING

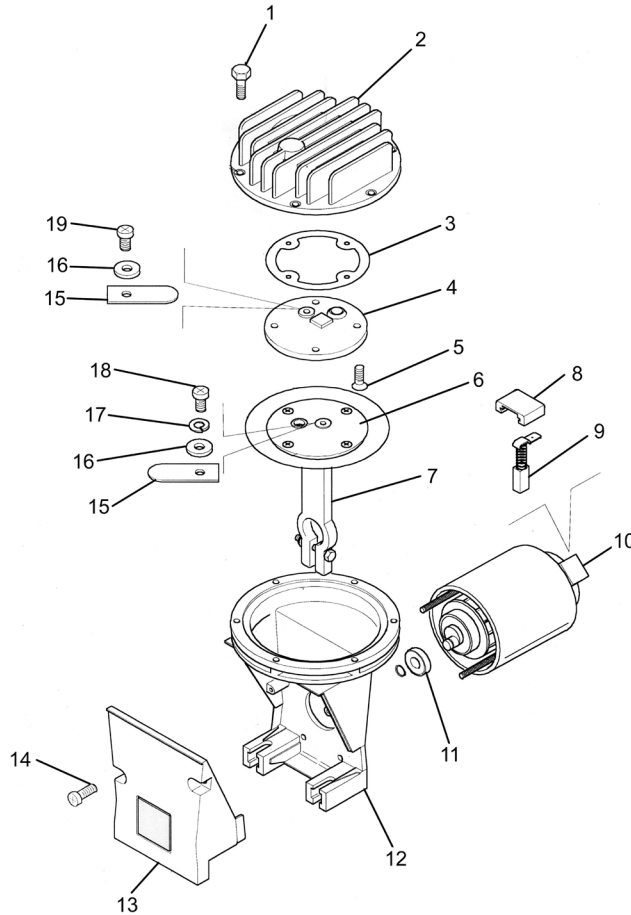

REF#	PART#	DESCRIPTION	QUANTITY
1†		Bolt	6
2		Head	1
3		Exhaust Manifold Gasket	1
4		Exhaust Manifold	1
5†		Manifold Screw	8
6†		Diaphragm	1
7†		Piston	1
8		Brush Retainer	2
9	15-505-06	Brush	2
10	15-505-07	12 Volt Electric Motor	1
11	15-505-05	Stainless Steel Bearing	1
12		Block	1
13		Cover	1
14		Cover Screw	2
15*		Exhaust Reed Valve	1
16*†		Washer	2
17*†		Split Lockwasher	1
18*†		Intake Valve Screw	1
19*		Exhaust Valve Screw	1
*	15-505-02	Intake Exhaust Valve Sub Assembly	
†	15-505-04	Intake Piston Sub Assembly	

14-291 FOAMER REPLACEMENT PARTS

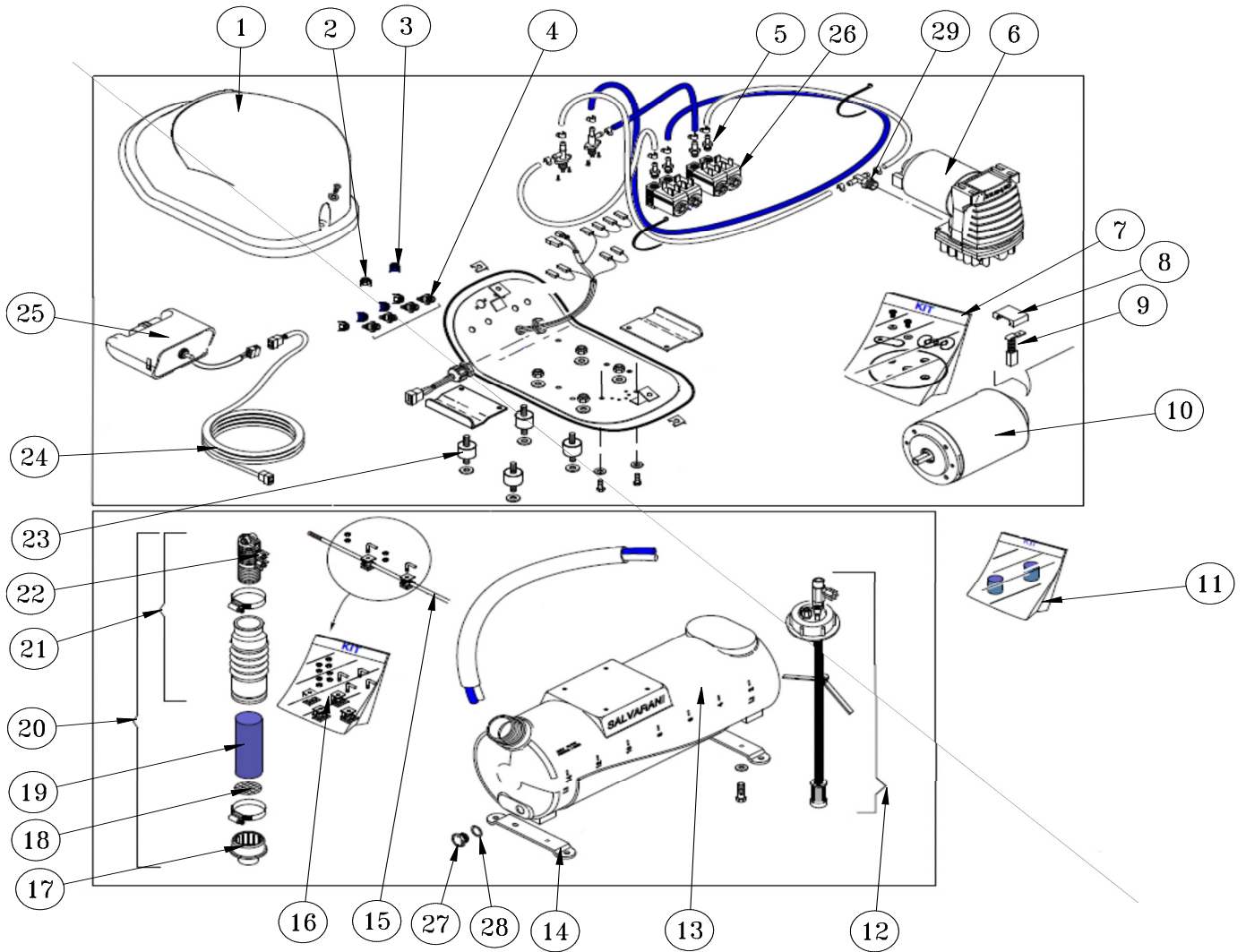

Accessories

14-291 FOAMER REPLACEMENT PARTS

REF#	PART#	DESCRIPTION	QUANTITY
1	14-291-01	Black Cover	1
2	14-291-08	White Fly Nut	1
3	14-291-09	Blue Fly Nut	1
4	14-284-10	Tubing Connector	1
5	14-291-17	M6 Tubing Connector	1
6	14-536	Compressor Complete	1
7	14-291-11	Diaphragm Replacement Kit	1
8	15-505-08	Brush Retainer	1
9	15-505-06	Brush	1
10	15-505-07	12V Electric Motor	1
11	15-511-02	Foam Sponge	1
12	14-284-02	Cap Assembly	1
13	14-291-02	Foamer Tank	1
14	14-291-04	Tank Brackets	2
15	15-510-01	Nozzle Mounting Rod	2
16	16-987	Foam Nozzle Mounting Kit	1
17	14-284-09	Foam Nozzle Reducer	2
18	15-511-09	Stainless Steel Screen	2
19	15-511-08	Long Foam Sponge	2
20	15-511	Foam Nozzle	2
21	15-511-07	Foam Nozzle Assembly	1
22	15-511-01	Foam Nozzle Sub Assembly	1
23	14-291-15	Shock Absorber	4
24	14-284-05	Extension Wire	1
25	14-291-05	Switch Box	1
	15-506-02	Switch	1

DECAL LIST

This is a list of decals located on the Ultra 15 Fairway Roller. Part number, description and location will help in reordering decals.

A	12-779	Decal, On/Off	1
B	12-780	Decal, Warning	1
C	12-781	Decal, Fairway Ultra 15	2
D	12-799	Decal, Warning Stay Back	4
E	25-277	Decal, Battery Warning	1
F	25-286	Decal, Pinch Points	4
G	25-374	Decal, Smithco 12"	1
H	25-355	Decal, Tire Pressure 18PSI	2
I	27-093	Decal, Hydraulic Fluid	1
J	45-648	Decal, Lift/Lower	1
K	76-307	Decal, Tower Warning	2

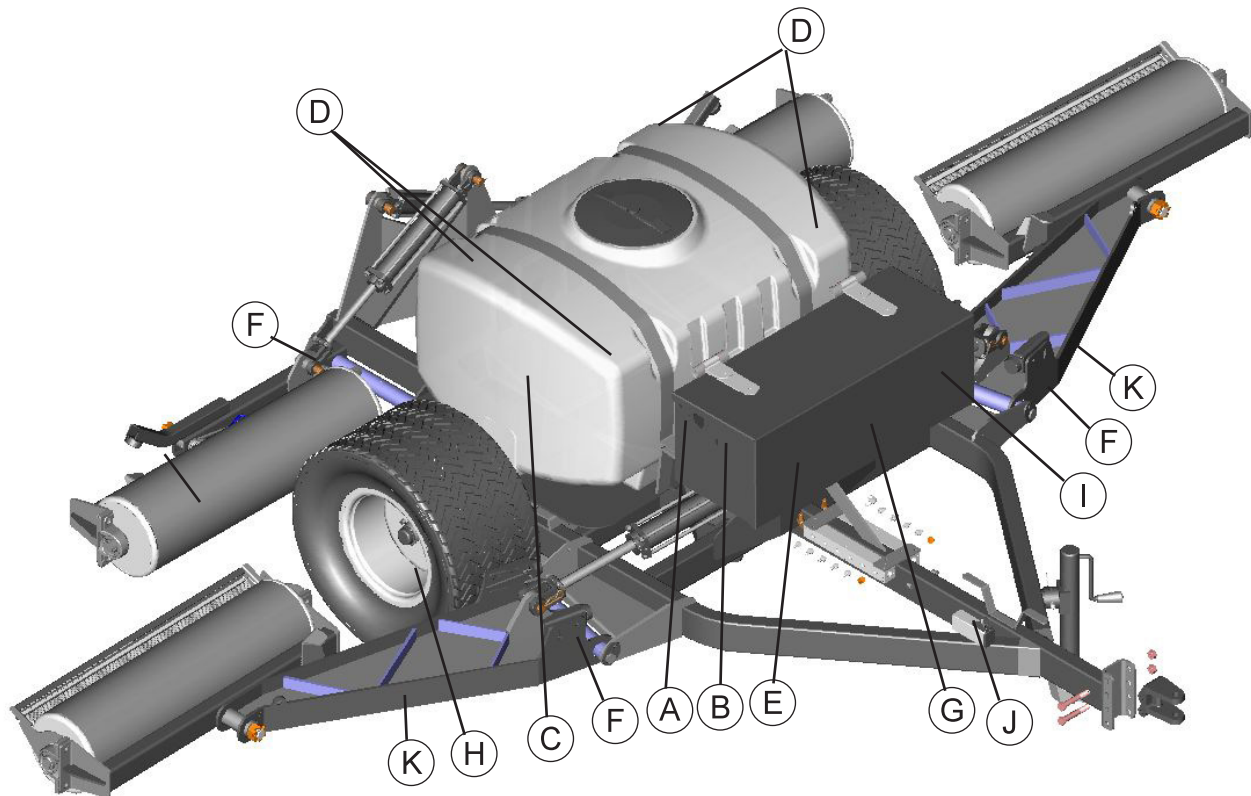

QUICK REFERENCE

Battery Automotive type 24F-12 Volt (**Smithco Part #33-216**)
Hydraulic Fluid 2 Gal (7,57liter) MileMaster 303 Tractor HYD Fluid (Smithco Part# 9042)

CYLINDERS

12-519 Hydraulic Cylinder
15-519-01 Seal Kit

12-514 Hydraulic Cylinder
12-514-01 Seal Kit

12-571 Hydraulic Cylinder
12-571-01 Seal Kit

The Smithco Commercial Products Two-Year Limited Warranty

Smithco, Inc. (Smithco) warrants your 2016 or newer Smithco Commercial Product (“Product”) purchased after October 1, 2016 to be free from defects in materials or workmanship for the period of time listed below. Where a warrantable condition exists, Smithco will repair the Product at no cost to you including diagnosis, labor (at the Smithco standard labor rate, subject to the Smithco flat rate schedule), and parts.

Warranty Duration is:

- (1) Two years, 1500 operational hours* from the date of delivery to the original purchaser or Five years from the date of original manufacturer of the product, whichever occurs first. (*Products equipped with hour meter).
- (2) Products used in rental situations are covered for 90 days from date of delivery to original user/renter.

Owner Responsibilities:

As the Product owner, you are responsible for required maintenance and adjustments stated in your Owner’s Manual. Failure to perform required maintenance and adjustments can be grounds for disallowing a warranty claim. **You are particularly responsible to train all present and future operators of this product on the safe operation of this product at your location.**

Instructions for Obtaining Warranty Service:

You are responsible for notifying the Authorized Smithco Products Distributor from whom you purchased the Product as soon as you believe a warrantable condition exists and not later than 30 days from discovery of the condition.

If you need help locating an Authorized Smithco Distributor, or if you have questions regarding your warranty rights or responsibilities, you may contact us at:

Smithco Product Support Department
200 West Poplar Ave.
Cameron, Wisconsin 54822
Telephone: 800-891-9435 E-Mail: ProductSupport@Smithco.com

Maintenance Parts:

Parts scheduled for replacement as required maintenance (“Maintenance Parts”), are warranted for the period of time up to the scheduled replacement time for that part.

Items/Conditions Not Covered:

Not all product failures or malfunctions that occur during the warranty period are defects in materials or workmanship. The items/conditions listed below are not covered by this warranty:



Product failures which result from the use of non-Smithco replacement parts, or from installation and use of add-on, modified, or unapproved accessories are not covered.



Product failures which result from failure to perform required maintenance and/or adjustments are not covered.



Product failures that result from operating the Product in an abusive, negligent or reckless manner are not covered.



This warranty does not apply to parts subject to consumption through use, unless found to be defective. Examples of parts which are consumed, or used up, during normal Product operation include, but are not limited to: blades, tines, teeth, scarifiers, rakes, plates, wear plates, castor wheels, tires, batteries, filters, belts, nozzles, etc.



This warranty does not apply to failures caused by outside influence. Items considered to be outside influence include, but are not limited to, weather, storage practices, contamination, use of unapproved coolants, lubricants, additives, or chemicals, etc.



This warranty does not apply to normal “wear and tear” items. Normal “Wear and Tear” includes, but is not limited to, damage to seats due to wear or abrasion, worn painted surfaces, scratched decals or windows, etc.



Smithco may require the return of failed parts or components in order to determine the validity of any warranty claim.



Smithco will not be obligated to replace components of other manufacturers if inspection by the original component manufacturer indicates that failure was due to normal wear and tear, expected consumption through use or improper care or service.

Other Legal Disclaimers:

The above remedy for product defects through repair or replacement by an authorized Smithco distributor or dealer is the purchaser’s sole remedy for any defect. This warranty gives you specific legal rights, and you may also have other rights which vary from state to state.

THERE ARE NO OTHER EXPRESS WARRANTIES OTHER THAN THOSE SET FORTH ABOVE. ALL IMPLIED WARRANTIES OF MERCHANTABILITY AND FITNESS FOR USE ARE LIMITED TO THE DURATION OF THE LIMITED WARRANTIES CONTAINED HEREIN.

Some states may not allow limitations on how long an implied warranty lasts, so the above limitation may not apply to you.

THE SMITHCO COMPANY IS NOT LIABLE FOR INDIRECT, INCIDENTAL OR CONSEQUENTIAL DAMAGES IN CONNECTION WITH THE USE OF THE PRODUCT, INCLUDING ANY COST OR EXPENSE OF PROVIDING A SUBSTITUTE PRODUCT OR SERVICE DURING PERIODS OF MALFUNCTION OR NON-USE.

Some states may not allow the exclusion of indirect, incidental or consequential damages, so the above exclusion may not apply to you.

Smithco neither assumes, nor authorizes any person to assume for it, any other liability in connection with the sale or use of this product.

