

Parts Manual



Sand Star III
45-003 3WD Hydraulic Steering
sn: 3HS0148

Product Support:

Hwy 55 & Poplar Ave; Cameron WI 54822

1-800-891-9435 productsupport@smithco.com

CONTENTS

Introduction	Introduction..... 1-3
	Introduction 1
	Safe Practices 2
Service	Specifications 3
	Service..... 4-11
	Maintenance 4-6
	Service Chart..... 7
	End User's Service Chart 8
	Adjustments 9-11
Diagrams	Storage 11
	Diagrams 12-15
	Wiring Diagram 12-13
Parts	45-003 Hydraulic Diagram 14-15
	Parts..... 16-49
	Main Frame 16-17
	Seat Panel 18-19
	Front Fork 20-21
	Dashboard 22-23
	Foot Pedal Linkage 24-25
	Fuel Tank 26-27
	Oil Tank..... 28-29
	Belts and Pulleys 30-31
	18 HP Engine..... 32-33
	Piston Pump 34-35
	Rear Axle 36-37
	Rear Rake Lift..... 38-39
	Center Lift 40
	13-729 Valve 41
	Front Wheel Motor 42
	Rear Wheel Motors..... 43
	Accessories
Orbitrol 46-47	
Decals..... 48	
Quick Reference 49	
Accessories 50-54	
Reference	Roll Bars 50-51
	45-316 Light Kit for ROPs..... 52-53
	45-390 Light Kit no ROPs..... 54
Attachments A-B-C	
Warranty 	

Thank you for purchasing a **Smithco** product.

Read this manual and all other manuals pertaining to the Bunker Rake carefully as they contain safety, operating, assembly and maintenance instructions. Failure to do so could result in personal injury or equipment damage.

Keep manuals in a safe place after operator and maintenance personnel have read them. Right and left sides are from the operator's seat, facing forward.

 **WARNING:**

Engine exhaust and some of its constituents are known to the State of California to cause cancer, birth defects, and other reproductive harm.
For more information visit
www.P65Warning.ca.gov

WARNING

Failure to follow cautious operating practices can result in serious injury to the operator or other persons. The owner must understand these instructions, and must allow only trained persons who understand these instructions to operate this vehicle.

All **Smithco** machines have a Serial Number and Model Number. Both numbers are needed when ordering parts. Serial number tag is located on left rear ROPs mount post. Refer to engine manual for placement of engine serial number.

For product and accessory information, help finding a dealer, or to register your product please contact us at www.Smithco.com.

Information needed when ordering replacement parts:

1. Model Number of machine
2. Serial Number of machine
3. Name and Part Number of part
4. Quantity of parts

For easy access record your Serial and Model numbers here.

SMITHCO WAYNE, PENNSYLVANIA 19087 USA 610-688-4009 Fax 610-688-6069			
SERIAL NO. <input type="text"/>	kW/hp <input type="text"/>	DATE OF MFG. <input type="text"/>	
MODEL NO. <input type="text"/>	lb/kg Empty <input type="text"/>	lb/kg Full <input type="text"/>	

SMITHCO CUSTOMER SERVICE 1-800-891-9435

SAFE PRACTICES

1. It is your responsibility to read this manual and all publications associated with this machine (engine, accessories and attachments).
2. Never allow anyone to operate or service the machine or its attachments without proper training and instructions. Never allow minors to operate any equipment.
3. Learn the proper use of the machine, the location and purpose of all the controls and gauges before you operate the equipment. Working with unfamiliar equipment can lead to accidents.
4. Wear all the necessary protective clothing and personal safety devices to protect your head, eyes, ears, hands and feet. Operate the machine only in daylight or in good artificial light.
5. Inspect the area where the equipment will be used. Beware of overhead obstructions and underground obstacles. Stay alert for hidden hazards.
6. Never operate equipment that is not in perfect working order or without decals, guards, shields, or other protective devices in place.
7. Never disconnect or bypass any switch.
8. Carbon monoxide in the exhaust fumes can be fatal when inhaled, never operate a machine without proper ventilation.
9. Fuel is highly flammable, handle with care.
10. Keep engine clean. Allow the engine to cool before storing and always remove the ignition key.
11. After engine has started, machine must not move. If movement is evident, the neutral mechanism is not adjusted correctly. Shut engine off and readjust so the machine does not move when in neutral position.
13. Never use your hands to search for oil leaks. Hydraulic fluid under pressure can penetrate the skin and cause serious injury.
14. This machine demands your attention. To prevent loss of control or tipping of the vehicle:
 - A. Use extra caution in backing up the vehicle. Ensure area is clear.
 - B. Do not stop or start suddenly on any slope.
 - C. Reduce speed on slopes and in sharp turns. Use caution when changing directions on slopes.
 - D. Stay alert for holes in the terrain and other hidden hazards.
15. Before leaving operator's position for any reason:
 - A. Disengage all drives.
 - B. Lower all attachments to the ground.
 - C. Shut engine off and remove the ignition key.
16. Keep hands, feet and clothing away from moving parts. Wait for all movement to stop before you clean, adjust or service the machine.
17. Keep the area of operation clear of all bystanders.
18. Never carry passengers.
19. Stop engine before making repairs/adjustments or checking/adding oil to the crankcase.
20. Use parts and materials supplied by **Smithco** only. Do not modify any function or part.

These machines are intended for professional maintenance on golf courses, sports turf, and any other area maintained turf and related trails, paths and lots. No guaranty as to the suitability for any task is expressed or implied.

WEIGHTS AND DIMENSIONS

Length	68" (1.73 m)
Width	58" (1.47 m)
Height	52" (1.2 m)
Wheel Base	42" (1.07m)
Ground Clearance	5.5" - 7" (13 -18 cm) - under cultivator depending on attachment
Weight	915 lbs. (415 kg)

SOUND LEVEL (EAR PROTECTION REQUIRED)

At Ear Level	87 dB
--------------	-------

ENGINE

Make	Briggs and Stratton Vanguard
Model#	356447
Type / Spec#	3559 G1
Horsepower	18 hp (13 kW)
Fuel	Unleaded 87 Octane Gasoline Minimum
Lubrication System	Full Pressure
Alternator	16 amp

WHEELS & TIRE

Three: 22 X 11 - 10.0 Knobby Tires 5 psi (.34 bar)
 Optional: 23-10.50 x 12 Turf Tires 5 psi (.34 bar)Smithco # 48-265

SPEED

Forward Speed	0 to 10 m.p.h. (0-16 kph)
Reverse Speed	0 to 5 m.p.h. (0-8 kph)

BATTERY

BCI Group	Lawn & Garden Size 35
Cold Cranking Amps	300
Ground Terminal Polarity	Negative (-)
Maximum Length	7.5" (19 cm)
Maximum Width	5" (12,7 cm)
Maximum Height	7.5" (19 cm)

FLUID CAPACITY

Crankcase Oil	See Engine Manual
Fuel	20 quarts (18.93 liters)
Hydraulic Fluid	20 quarts (18.93 liters)
Grade of Hydraulic Fluid	SAE 10W-40 API Service SJ or higher Motor Oil

ROPS CERTIFICATION

Rops	ISO 21299
Seat belts	OSHA 1928.51

HYDRAULIC PRESSURES

Piston Pump Displacement	.913 in ³	Charge Pump Displacement	.33 in ³ /rev
Pump Input Speed (up to)	3300rpm	Max. Inlet Vacuum	5 in. Hg
Max. Operating Pressure	3000 peak psi	Max. Case Pressure	25 psi
Implement Setting	345 psi	Relief Valve Pressure (set at)	1230 psi
13-729 Hydraulic Valve (2 bank)	900 psi		

MAINTENANCE

⚠ CAUTION

Before servicing or making adjustments to machine, stop engine and remove key from ignition.

⚠ IMPORTANT

Use all procedures and parts prescribed by the manufacturer's. Read the engine manual.

LUBRICATION

Use No. 2 General purpose Lithium Base Grease and lubricate every 100 hours. The Sand Star has four grease fittings. One located on the steering cylinder, one on the rod end of the center lift cylinder, and two on the foot pedal mount.

REMOTE AIR CLEANER

1. Unclip the two clips, remove the cover and pull out the element.
2. To service, clean by tapping gently on flat surface. Do not oil. Replace if very dirty or damaged.
3. Clean out the inside of the body and cover.
4. Place the element into the body and put the cover back on.

TOWING

When it is necessary to move the Super Star without engine running, bypass valve built into hydrostatic pump must be "open" by turning it counterclockwise. The valve is A 17mm bolt on the top of the pump. An "open" valve allows fluid to pass through the wheels freely. When normal, driven, operation is desired, valve should be "closed" by turning it clockwise. Failure to "close" the valve with engine running means no power to wheels. The machine can be moved for a short distance with the engine off, but we **do not** recommend this as a standard procedure. When towing **do not** tow the machine faster than 2-3 MPH (3-5 km/h) because the drive system may be damaged. The tires may lock up if the machine is towed too fast. If this occurs, stop towing the machine. If the machine must be moved a considerable distance, transport it on a truck or trailer.

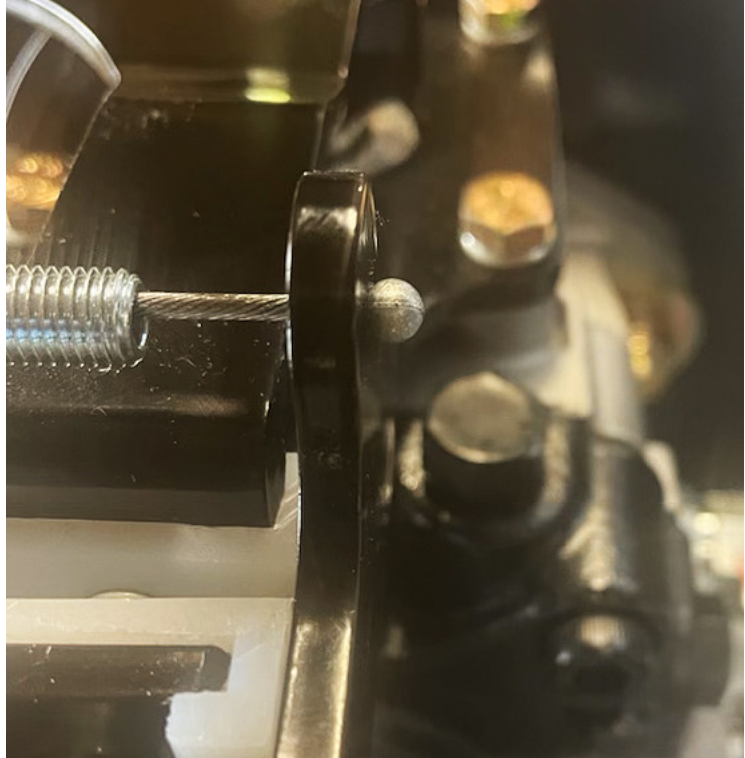

TIRE PRESSURE

Caution must be used when inflating a low tire to recommended pressure. Over inflating can cause tires to explode. Tires should be 5 psi (0.34 bar). Improper inflation will reduce tire life considerably.

ENGINE

Change and add oil according to chart below. Do not overfill. Use a high quality detergent oil classified "For Service SJ or higher" SAE 30 oil. Use no special additives with recommended oils. Do not mix oil with gasoline.

SAE VISCOSITY GRADES

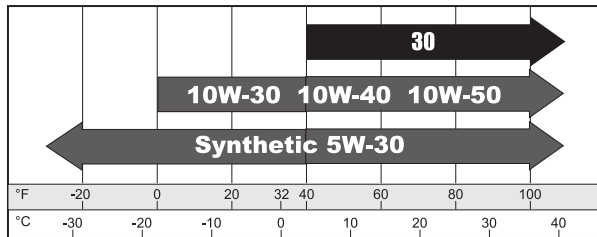

A quick twist and pull motion to open, push to close. Allows a quick and easy way to change oil without the mess



Engine Oil Drain Valve

Starting Temperature Range Anticipated Before Next Oil Change

Use of multi-viscosity oils (10W-30, etc.) above 40° F (4° C) will result in high oil consumption and possible engine damage. Check oil level more frequently if using these types of oils.

SAE 30 oil, if used below 40° F (4° C), will result in hard starting and possible engine bore damage due to inadequate lubrication.

HYDRAULIC OIL

1. Use SAE 10W-40 API Service SJ or higher motor oil.
2. For proper warranty, change oil every 500 hours or annually, whichever ever is first and change filter after the first 50 hours, then every 250 hours thereafter.
3. The oil level should be 2" to 2 1/2" from top of tank when fluid is cold. Do not overfill.
4. After changing oil and/or filter, run the machine for a few minutes. Check oil level and for leaks.
5. Always use caution when filling hydraulic oil tank or checking level to keep system free of contaminants. Check and service more frequently when operating in extremely cold, hot or dusty conditions.
6. If natural color of fluid is black or smells burnt, it is possible that an overheating problem exists.
7. If fluid becomes milky, water contamination may be a problem.
8. If either of the above conditions happen, change oil and filter immediately after fluid is cool and find cause. Take fluid level readings when system is cold.
9. In extreme temperatures you can use straight weight oil. We recommend SAE 30W API Service SJ or higher when hot (above 90°F (33°C)) and SAE 10W API Service SJ or higher when cold (below 32°F (0°C) ambient temperature. Use either motor oil or hydraulic oil, but do not mix.
10. Oil being added to the system must be the same as what is already in the tank. Mark tank fill area as to which type you put in.

MAINTENANCE

WHEEL MOUNTING PROCEDURE

1. Turn machine off and remove key.
2. Block one of the other wheels.
3. Loosen nuts slightly on wheel to be removed.
4. Jack up machine being careful not to damage underside of machine.
5. Remove nuts. Remove wheel.
5. Place new wheel on hub lining up bolt holes.
6. Torque nuts to 64-74 ft/lb (87-100 Nm) using a cross pattern. Re-torque after first 8 hours and every 250 hours thereafter.
7. Lower machine to ground and remove blocks and jack.

BATTERY

Batteries normally produce explosive gases which can cause personal injury. Do not allow flames, sparks or any ignited object to come near the battery. When charging or working near battery, always shield your eyes and always provide proper ventilation.

Battery cable should be disconnected before using "Fast Charge".

Charge battery at 15 amps for 10 minutes or 7 amps for 30 minutes. Do not exceed the recommended charging rate. If electrolyte starts boiling over, decrease charging.

Always remove grounded (-) battery clamp first and replace it last. Avoid hazards by:

1. Filling batteries in well-ventilated areas.
2. Wear eye protection and rubber gloves.
3. Avoid breathing fumes when electrolyte is added.
4. Avoid spilling or dripping electrolyte.

⚠ WARNING

Battery Electrolyte is an acidic solution and should be handled with care. If electrolyte is splashed on any part of your body, flush all contact areas immediately with liberal amounts of water. Get medical attention immediately.

JUMP STARTING

⚠ WARNING

Use of booster battery and jumper cables. Particular care should be used when connecting a booster battery. Use proper polarity in order to prevent sparks.

To jump start (negative grounded battery):

1. Shield eyes.
2. Connect ends of one cable to positive (+) terminals of bottom post on solenoid first (A), then positive post of booster battery. (B).
3. Connect one end of other cable to negative (-) terminal of booster battery (C).
4. Connect other end of cable (D) to engine block on unit being started.

To prevent damage to other electrical components on unit being started, make certain that engine is at idle speed before disconnecting jumper cables.

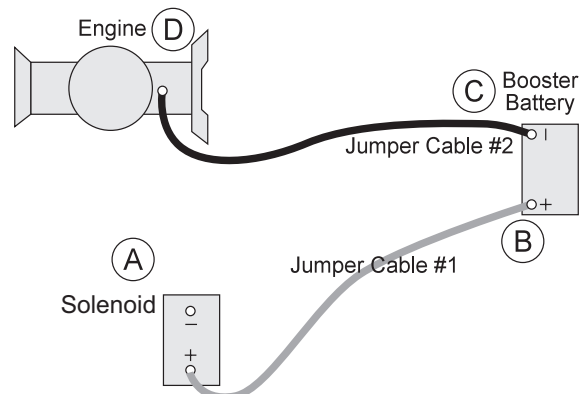

⚠ CAUTION

Before servicing or making adjustments to the machine, stop engine, set park break, block wheels and remove key from ignition.

⚠ IMPORTANT

Follow all procedures and **ONLY** use parts prescribed by the manufacturer. Read the engine manual before maintenance.

The suggested maintenance checklist is not offered as a replacement for the manufacturer's engine manual but as a supplement. You must adhere to the guidelines established by the manufacturer for warranty coverage. In adverse conditions such as dirt, mud or extreme temperatures, maintenance should be more frequent.

Maintenance Service Interval	Maintenance Procedure
After the first 8 operating hours	Torque the wheel lug nuts. (64-74 ft/lb (87-100 Nm)) Change the engine oil filter.
Before each use daily	Check the engine oil level. Clean area around muffler and controls. Check the hydraulic fluid level. Check the tire pressure. Check condition of hydraulic hoses and fittings. Inspect and clean the machine.
After the first 50 hours	Change Hydraulic Oil Filter.
Every 100 hours	Clean or change air filter. ¹ Clean pre-cleaner. ¹ Change engine oil and filter. Replace spark plug . Lubricate machine. Clean or change remote air cleaner. Check the battery fluid level and cable connections.. Check muffler and spark arrestor. Check belt tension .
Every 250 hours	Check engine valve clearance and adjust if necessary. Check idle speed. Clean battery terminals. Change hydraulic oil filter. Torque the wheel lug nuts. (64-74 ft/lb (87-100 Nm))
Every 500 hours or yearly	Change fuel filter. Change hydraulic oil and filter. Clean oil cooler fins. ¹ Clean air cooling system. ¹ Check safety filter in remote air cleaner.

¹ In dusty conditions or when airborne debris is present, clean more often.

RAKE LIFT CYLINDER

Completely lower Rake Lift. Remove the clevis pin (A). Twist lift linkage (C) so clevis pin end of cylinder extension lines up with holes in attachment lift arm (B). Replace clevis and cotter pins. Tighten Jam Nut (D). Raise and lower Rake Lift to check for proper clearance.

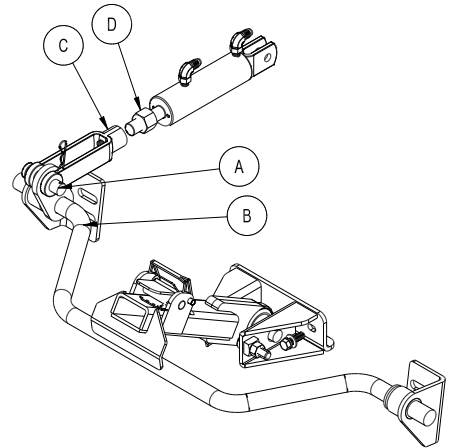

Tighten until there is sufficient tension between lift arm and quick hitch and will not move in full up position.

CAUTION

When the rear rake attachment is lowered while the machine is in forward motion, the forward speed of the machine will slow drastically. Operator should be prepared for a rapid change in speed.

PARK BRAKE

The park brake is located on the left hand side of the machine and operates both rear wheels. Pull lever back to engage and push forward to disengage.

To adjust, turn the knob on the end of the handle.

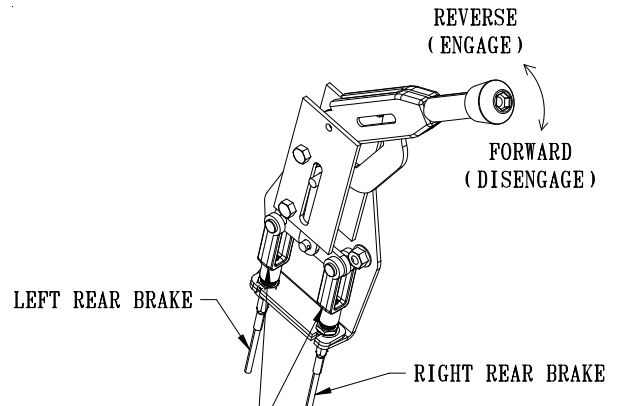

DRUM BRAKE ADJUSTMENT

The brake can be adjusted through the access hole in the backing plate. Remove the rubber plug from the backing plate. Using a drum brake adjusting tool, or a suitable flat blade screw driver, rotate the adjusting star towards the axle shaft to expand the shoes, one click at a time. Expand the shoes until slight contact is made with the drum. It is highly recommended that you adjust 1 click at a time. Rotate the drum back and forth to insure the brake is not rubbing excessively, if so back off the adjuster star. Slight rubbing is acceptable as the brake is used it will seat in. Test after each adjustment.

Brake Adjustment



Adjustment Gear

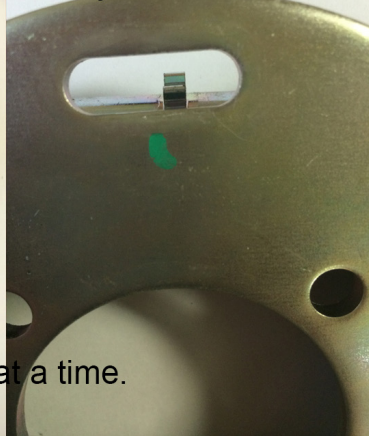

ADJUSTMENTS

WHEEL 'CREEP' ADJUSTMENT

'Creep' is when engine is running and hydrostatic transmission is in neutral, but due to inadequate alignment, wheels still move. Do the following procedures to stop this motion.

1. Lift up and support machine so all wheels are off the ground and can turn freely.
2. On the top of the pump there is a Creep Arm. Loosen bolts.
3. With engine running adjust the creep arm side to side in slot so centering arm centers on the swash plate.
4. Tighten all fasteners and test by using foot pedal linkage to see that the "creep" is removed.
5. Turn engine off and lower machine.

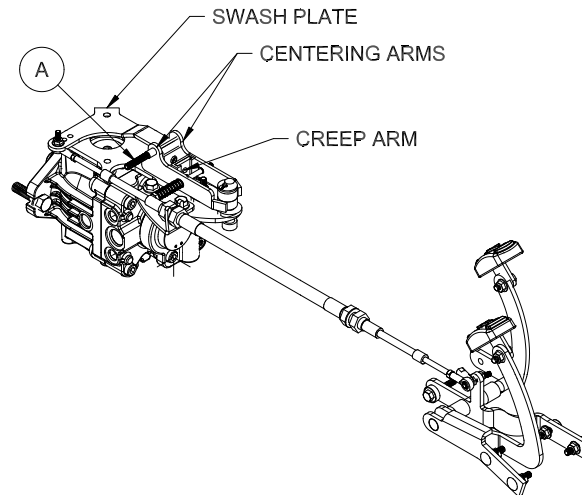

TO ADJUST FOOT PEDAL THROTTLE CABLE

1. Jack up unit so that all drive wheel are off the ground. (Use jack stands)
2. Start the engine, make certain that the hand throttle is in the idle position (1200 engine RPM).
3. Engine speed must increase as soon as the foot pedal begins to move in either direction. At the full forward position, the engine RPM must be 3300RPM \pm 100.
4. Minor adjustment can be made by backing out (unscrewing) Retainer (Ref A) until you reach full engine RPM with the foot pedal fully depressed in the forward position. Be sure to recheck after the nuts are fully tightened.
5. Major adjustment needs to be made by pulling the slack out of the cable. Loosen the screw in the wire block on the engine that is clamped onto the end of the cable and sliding it up to the cable block that is through the throttle plate. Do not let the throttle plate move to increase idle speed. Tighten the screw.
6. Test run to determine that there is no binding and that engine idle speed is 1200 RPM and that it is 3300RPM at full forward position of the foot pedal.

SPEED BOSS

Speed Boss allows the machine to operate at a proper speed while raking sand traps on golf courses. This speed boss has been factory set at an average speed of 3-4 m.p.h. (5-6.5 kph). The Speed Boss will only limit the speed while the rake is lowered into the operating position. The speed setting may be adjusted by turning the Ball Joint (A) counterclockwise and replace to make the machine operate slower or turn clockwise to go faster. Tighten jam nut. Check to make sure nothing is binding and test drive to check desired speed.

For RBS System, Spiker and Grader Box remove the speed boss arm and the speed boss rod from machine so it does not interfere with other operations.

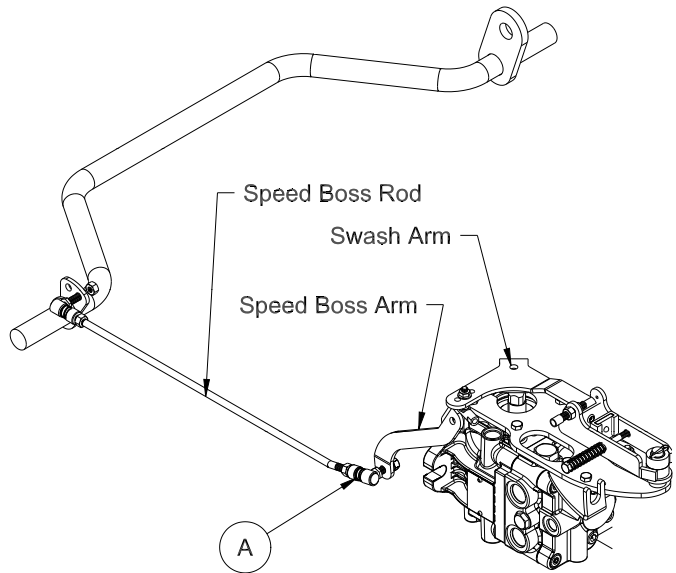

ADJUSTMENT OF BELT TENSIONER

The belt tensioner controls the tension on the belt from the engine to the pump. The proper tension of the idler should be in the second notch on the side of the tensioner. Over tightening the belt will shorten the life of the belt and the machine may not perform to the best of its ability. To adjust belt tensioner, loosen the bolt holding the tensioner. Bring idler pulley tight to the belt and turn tensioner into belt to the second notch. Tighten bolt on tensioner.

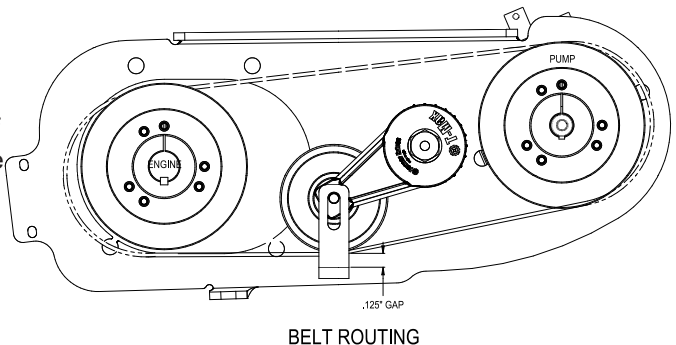

STORAGE

When storing, remove the key from the key switch to avoid unauthorized persons from operating machine.

1. Before storing clean machine thoroughly.
2. Check bolts and nuts, tighten as necessary.
3. Make all repairs that are needed and remove any debris.
4. Remove the battery, adjust the electrolyte level and recharge it. Store the battery in a dry, dark place.
5. Store in a clean and dry area, but NOT near a stove, furnace or water heater which uses a pilot light or any device that can create a spark.
6. Engines stored over 30 days need to be protected or drained of fuel to prevent gum from forming in a fuel system or on essential carburetor parts. Check the engine manual and follow the instructions for the storage of the engine.

WIRING DRAWING

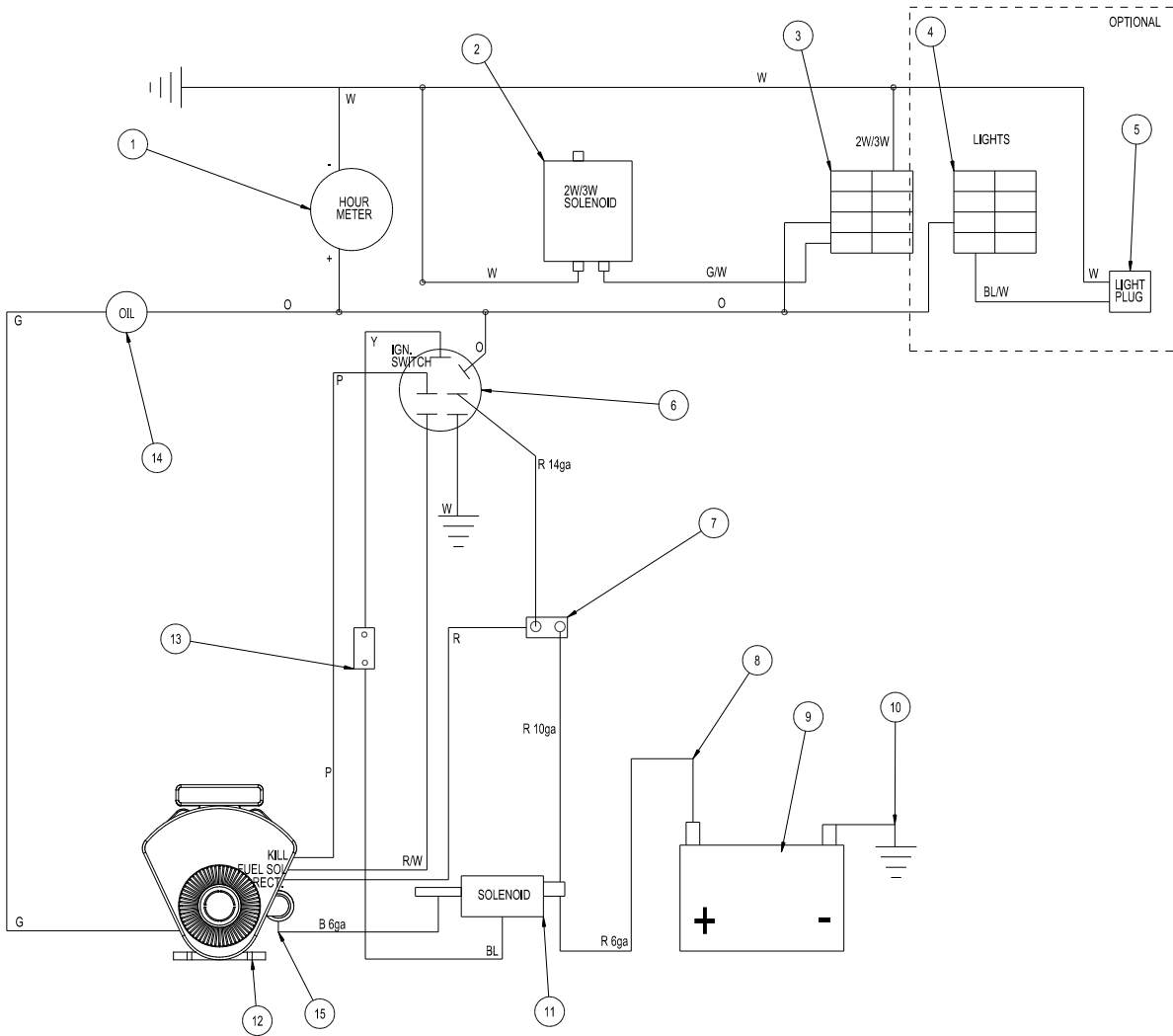

Diagrams

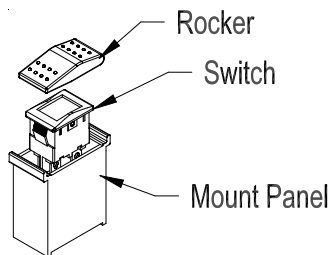

Color Code Chart

Bl	Blue
Br	Brown
Y	Yellow
Grn	Green
O	Orange
R	Red
B	Black
P	Purple
W	White

WIRING PARTS LIST

REF #	PART #	DESCRIPTION	QUANTITY
1	12-804	Hour Meter	1
	8875	Bullet Terminal	1
2	42-118	Electric On-Off Valve	1
	42-118-01	Coil	1
3	Electric On-Off Switch		
	15-725	Mount Panel End	1
	15-726	Switch Body Light	1
	15-731	Actuator Amber	1
4‡	Lights Switch (Optional)		
	15-729	Mount Panel Middle	1
	15-727	Switch Actuator, no light	1
	15-782	Rocker Switch, Unlit	1
5‡	34-201	Lights (Optional)	3
	43-505	Lights Wire Harness	1
6	13-488	Ignition Switch	1
7	8975	Circuit Breaker, 30AMP	1
	8977	Breaker Boot	1
8	45-119	Red Battery Cable	1
9		Battery (not included)	1
10	22-065	Black Battery Cable	1
11	13-750	Starter Solenoid w/ Connector	1
12	43-024	18hp Briggs & Stratton	1
13	14-292	Seat Switch	1
14	50-359	Warning Indicator Lights	1
15	22-017	Starter Cable	1
	45-042	Wire Harness	1
‡	45-016 Light Kit for ROPs		
	45-390 Light Kit		

HYDRAULIC DRAWING

Diagrams

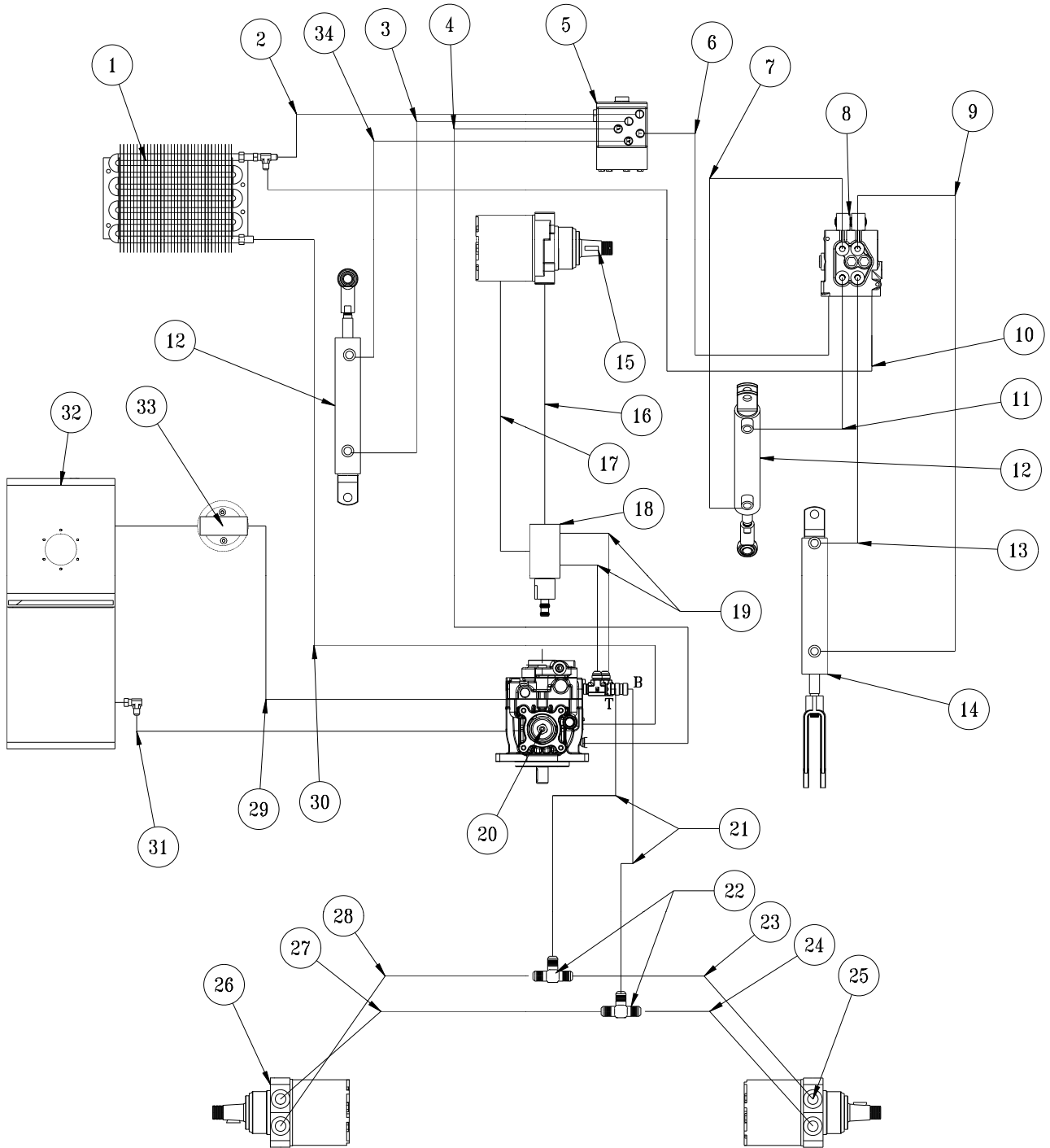

HYDRAULIC PARTS LIST

REF #	PART #	DESCRIPTION	QUANTITY
1	45-382	Cooler	1
2	45-024	Hydraulic Hose 37.5"	1
3	45-025	Hydraulic Hose 29"	1
4	45-023	Hydraulic Hose 45"	1
5	34-103	Orbitrol	1
6	45-027	Hydraulic Hose 40"	1
7	45-028	Hydraulic Hose 21.5"	1
8	13-729	2-Bank Hydraulic Valve	1
9	45-030	Hydraulic Hose 47"	1
10	45-032	Hydraulic Hose 17.5"	1
11	45-029	Hydraulic Hose 27"	1
12	10-554	Steering Cylinder	2
	18-154	Rod End	2
	HNJ-58-14	Jam Nut, $\frac{5}{8}$ - 14	2
13	45-031	Hydraulic Hose 50"	1
14	43-150	Rake Cylinder	1
	42-040	Yoke End	1
15	45-067	Front Wheel Motor	1
16	45-034	Hydraulic Hose 53"	1
17	45-035	Hydraulic Hose 50"	1
18	42-118	Electric On/Off Valve	1
19	45-033	Hydraulic Hose 11.5"	2
20	45-373	Hydrostatic Pump	1
	45-373-01	Overhaul Kit	1
21	45-037	Hydraulic Hose 12.5"	2
22	18-170	Tee	2
23	45-041	Right Upper Steel Tube	1
24	45-040	Right Lower Steel Tube	1
25	45-065	Right Wheel Motor w/ Brake	1
26	45-066	Left Wheel Motor w/ Brake	1
27	45-039	Left Upper Steel Tube	1
28	45-038	Left Lower Steel Tube	1
29	8832	$\frac{3}{4}$ " Suction Hose	30"
	18-040	Hose Clamp	2
30	45-365	Hydraulic Hose 35.5"	1
31	45-366	Hydraulic Hose 52.5"	1
32	42-005	Oil Tank	1
	13-747	Filler Breather	1
33	23-006	Oil Filter	1
	23-031	Replacement Filter only	
34	45-136	Hydraulic Hose 24"	1

Diagrams

HYDRAULIC PRESSURES

Pump Displacement	.913 in ³ /rev	Charge Pump Displacement	.33 in ³ /rev
Pump Input Speed (up to)	3300rpm	Max. Inlet Vacuum	5 in. Hg
Max. Operating Pressure	3000 peak psi	Max. Case Pressure	25 psi
Implement Setting	700-1000 psi	Relief Valve Pressure (set at)	3000 psi
13-729 Hydraulic Valve (2 bank)	900 psi		



MAIN FRAME DRAWING

Diagrams

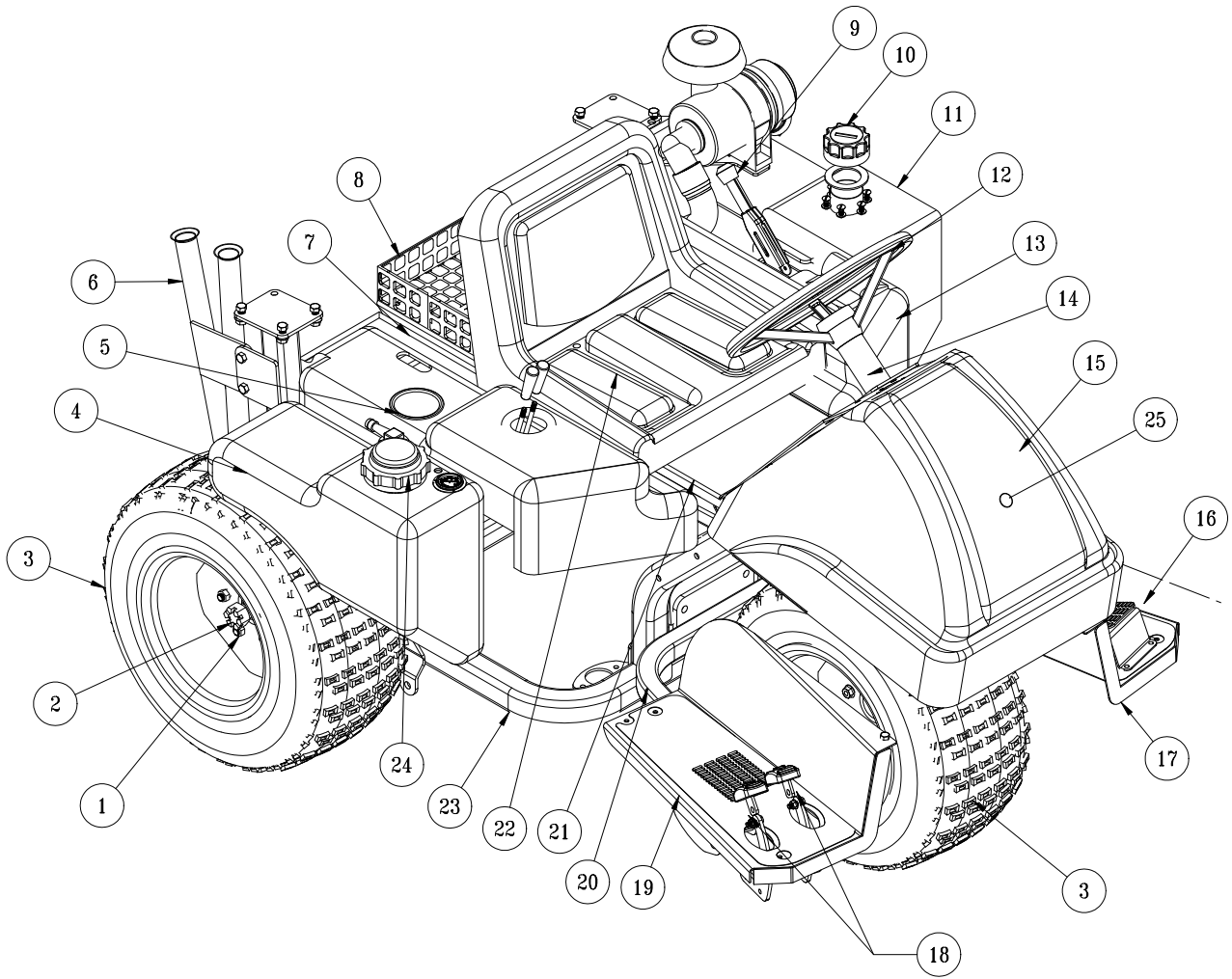

**Cyclonic air cleaner
42-834**

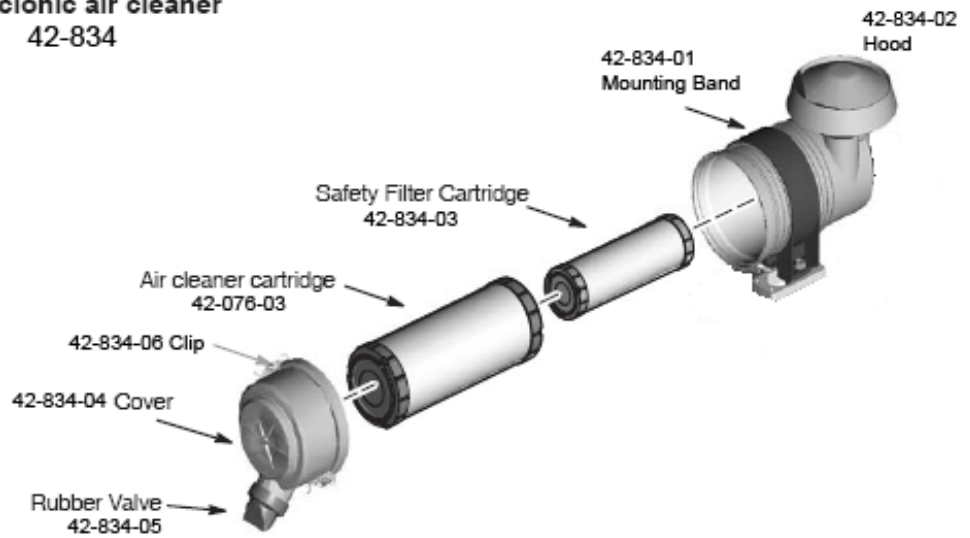

MAIN PARTS LIST

REF#	PART#	DESCRIPTION	QUANTITY
1	HNL-12-20	Lug Nuts, 1/2 - 20	10
2	14-265	Axle Nut (part of wheel motor)	3
3	45-021	Knobby Tire and Wheel	3
	45-021-01	Tire, 22 x 11 - 10	3
	45-021-02	Wheel	3
4	42-833	Fuel Tank	1
5	15-781	Cup Holder	1
6	45-123	Rake Holder	1
7	45-043	RH Fender	1
	8803-11	Black Trim, 11"	1
8	8-532	Crate	1
9	60-106	Park Brake Lever	1
10	13-747	Filler Breather	1
	13-586-03	Neck	1
11	42-005	Oil Tank	1
12	20-057	Steering Wheel	1
	20-129	Center Cap	1
13	45-044	LH Fender	1
14	45-157	Steering Post	1
15	45-026	Nose Cone	1
	8803-45	Black Trim, 45"	1
	18-436	Lock Hole Plug	1
16	45-047	Foot Rest Plate	1
	45-132	Foot Rest Grip	1
17	45-099	LH Floorboard	1
	45-064	LH Floor Mat	1
18	45-022	Molded Foot Pedal	2
19	45-098	RH Floorboard	1
	45-063	RH Floor Mat	1
20	45-145	Floorboard Frame	1
21	45-085	Seat Panel	1
22	14-293	Adjustable Low Back Seat	1
	14-800	Seat Rails	1
23	45-401	Main Frame	1
24	42-814-02	Fuel Cap	1

OPTIONAL TURF TIRES

48-265	Tire & Wheel	3
43-123-01	Turf Tires, 5 psi (.34 bar)	3
16-857-02	Wheel, 23-10.50 x 12	3

SEAT PANEL DRAWING

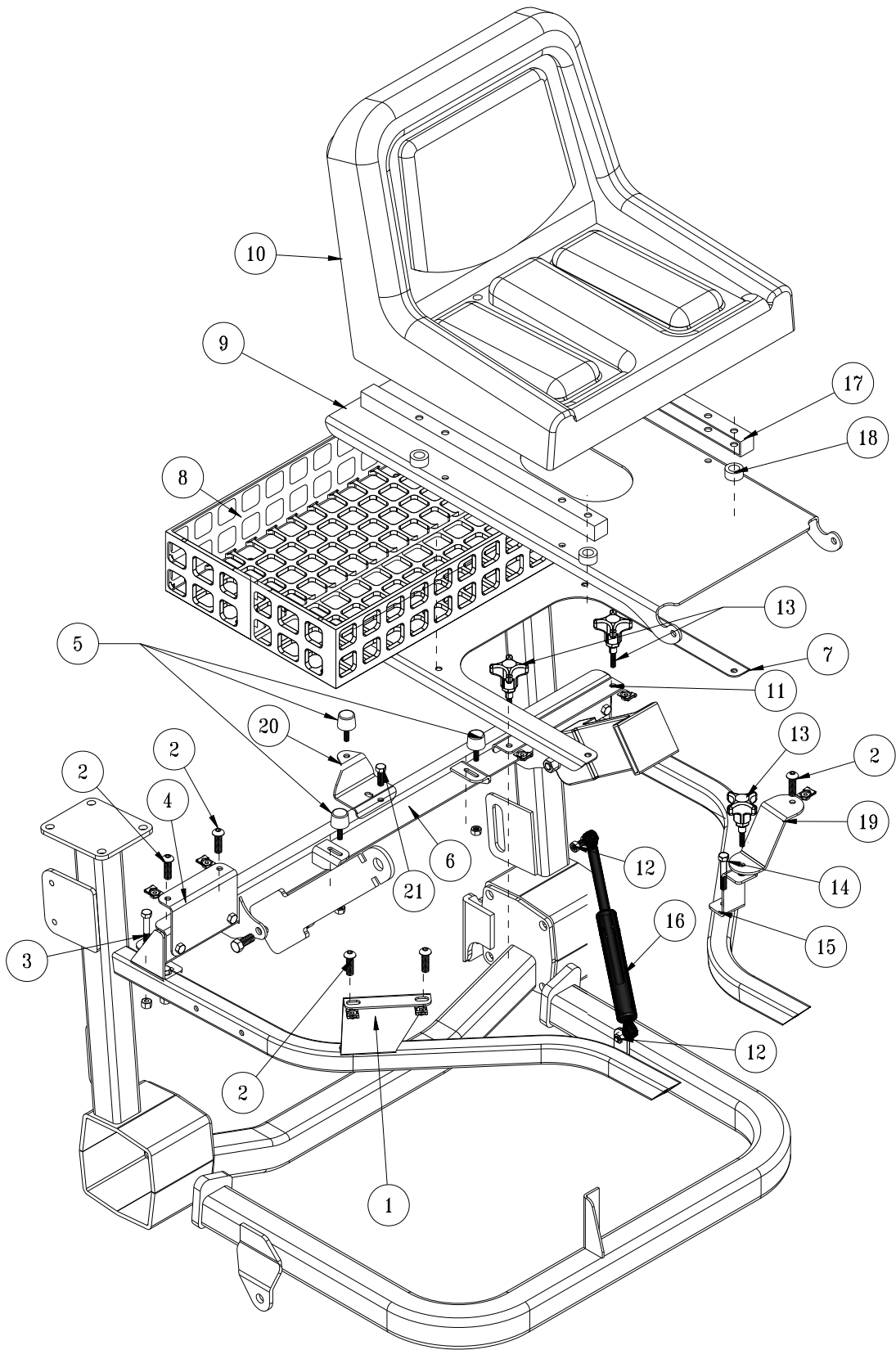

Parts

SEAT PANEL PARTS LIST

REF#	PART#	DESCRIPTION	QUANTITY
1	45-407	RH Fender Support	1
2	HSTP-516-18-100	Phillips Machine Screw, $\frac{5}{16}$ - 18 - 1	7
	78-274	Cage Nuts	7
3	HB-516-18-200	Hex Bolt, $\frac{5}{16}$ - 18 x 2	4
	HW-516	Flat Washer, $\frac{5}{16}$	4
	HNFL-516-18	Flange Whiz-Loc Nut, $\frac{5}{16}$ - 18	4
4	45-086	RH Rear Fender Bracket	1
5	15-013	Rubber Bumper	3
	HNTL-14-20	Nylon Lock Nut, $\frac{1}{4}$ - 20	3
6	45-402	Seat Belt Brace	1
7	45-088	Basket Mount	1
8	8-532	Basket	1
9	45-410	Seat Panel	1
10	14-293	Adjustable Low Back Seat	1
11	45-113	LH Rear Fender Mount	1
12	26-034	Ball Stud	2
	HNFL-516-18	Flange Whiz-Loc Nut, $\frac{5}{16}$ - 18	2
13	45-411	Knob Handle, $\frac{1}{4}$ -20	3
14	HB-516-18-200	Hex Bolt, $\frac{5}{16}$ - 18 x 2	1
	HW-516	Flat Washer, $\frac{5}{16}$	1
	HNFL-516-18	Flange Whiz-Loc Nut, $\frac{5}{16}$ - 18	1
15	45-408	LH Front Fender Mount	1
16	45-356	Gas Spring	1
17	14-800	Seat Rails	1
18	HSP-1260-340-250	Spacer	4
	HB-516-18-100	Hex Bolt, $\frac{5}{16}$ - 18 x 1	4
19	45-384	LH Front Fender Brace	1
20	45-414	Basket Bracket	1
21	HB-516-18-100	Hex Bolt, $\frac{5}{16}$ - 18 x 1	1
	HNFL-516-18	Flange Whiz-loc nut, $\frac{5}{16}$ -18	1

FRONT FORK DRAWING

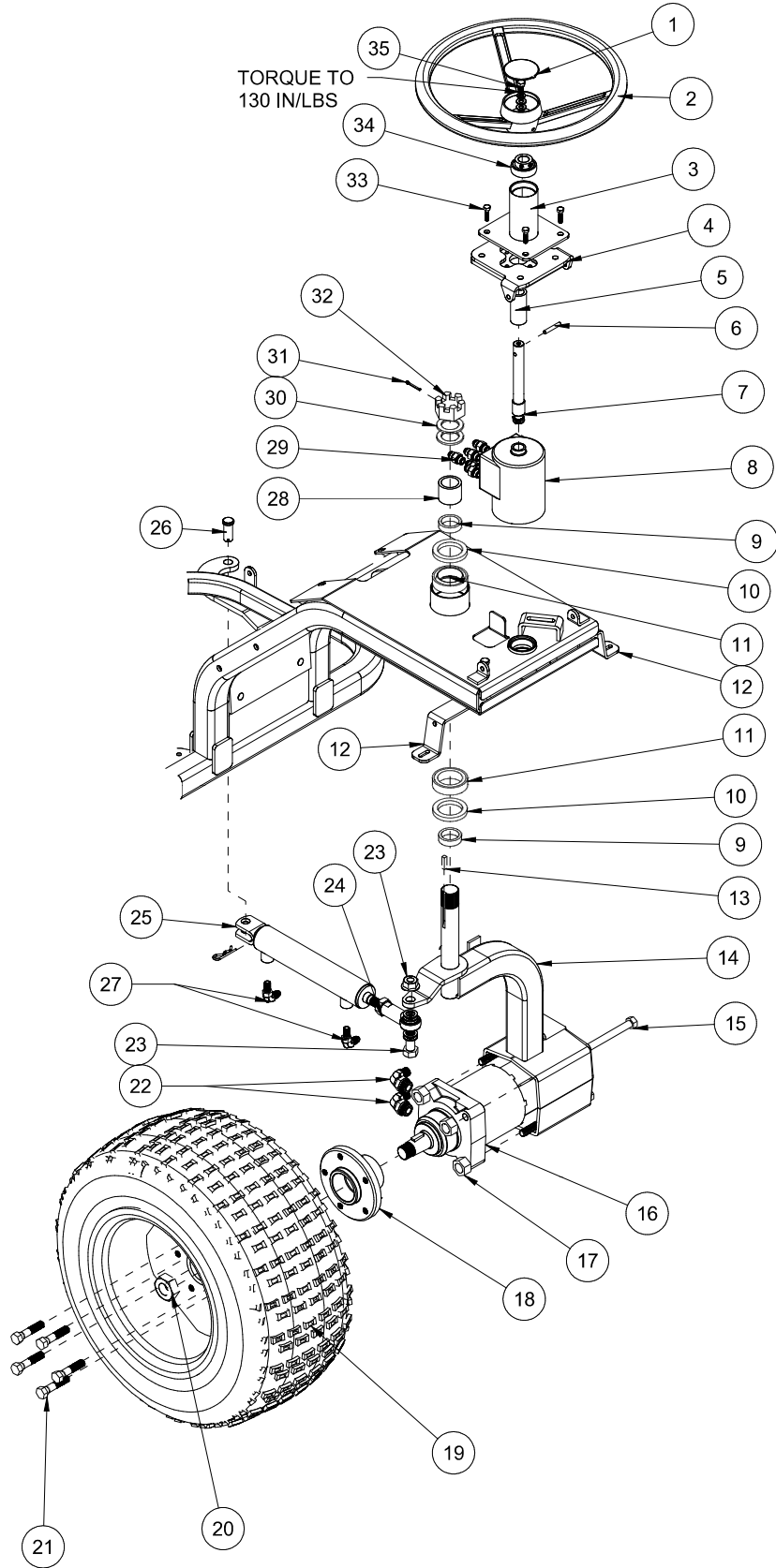

Parts

FRONT FORK PARTS LIST

REF#	PART#	DESCRIPTION	QUANTITY
1	20-129	Center Cap	1
2	20-057	Steering Wheel	1
3	45-157	Steering Post	1
4	45-423	Adapter Plate	1
5	76-649	Shaft Spacer	1
6	HRP-14-150	Roll Pin, ¼ x 1½	1
7	76-529	Steering Shaft	1
8	34-103	Orbitrol	1
9	20-141	Spacer	2
10	20-142	Oil Seal	2
11	20-143	Bearing	2
12	45-093	Front Support	2
13	HKSQ-14-100	Square Key, ¼ x ¼ x 1	1
14	45-115	Front Fork	1
15	HB-12-13-750	Hex Bolt, ½ - 13 x 7½	4
16	45-067	Front Wheel Motor	1
17	HNFL-12-13	Flange Lock Nut, ½ - 13	4
18	13-033	Hub	1
19	45-021	Knobby Tire and Wheel	1
	45-021-01	Tire, 22 x 11 x 10	1
	45-021-02	Wheel	1
20	14-265	Nut (part of wheel motor)	1
21	60-268	Lug Bolt	5
22	18-350	90° Seal Lock Elbow	2
23	HB-58-11-250	Hex Bolt, ⅝ - 11 x 2½	1
	HMB-58-14	Machine Bushing, ⅝ x 14GA	2
	HNTL-58-11	Lock Nut, ⅝ - 11	1
24	18-154	Rod End	1
	HNJ-58-18	Jam Nut, ⅝ - 18	1
25	10-554	Hydraulic Cylinder	1
	14-529	Seal Kit	1
26	HCP-58-150	Clevis Pin, ⅝ x 1½	1
	HHP-18	Bridge Pin, ⅛	1
27	18-168	⅜ Straight Thread Elbow	2
28	43-027	Shaft Spacer	1
29	18-169	Adapter ⅜ SAE	5
30	HMB-114-10	Machine Bushing, 1¼ x 10GA	1
31	HP-18-200	Cotter Pin, 1/8 x 2	1
32	HNA-114-12	Axle Nut, 1¼ - 12	1
33	HB-38-16-100	Hex Bolt, - ⅜ - 16 x 1	4
34	45-155	Bearing	1

DASHBOARD DRAWING

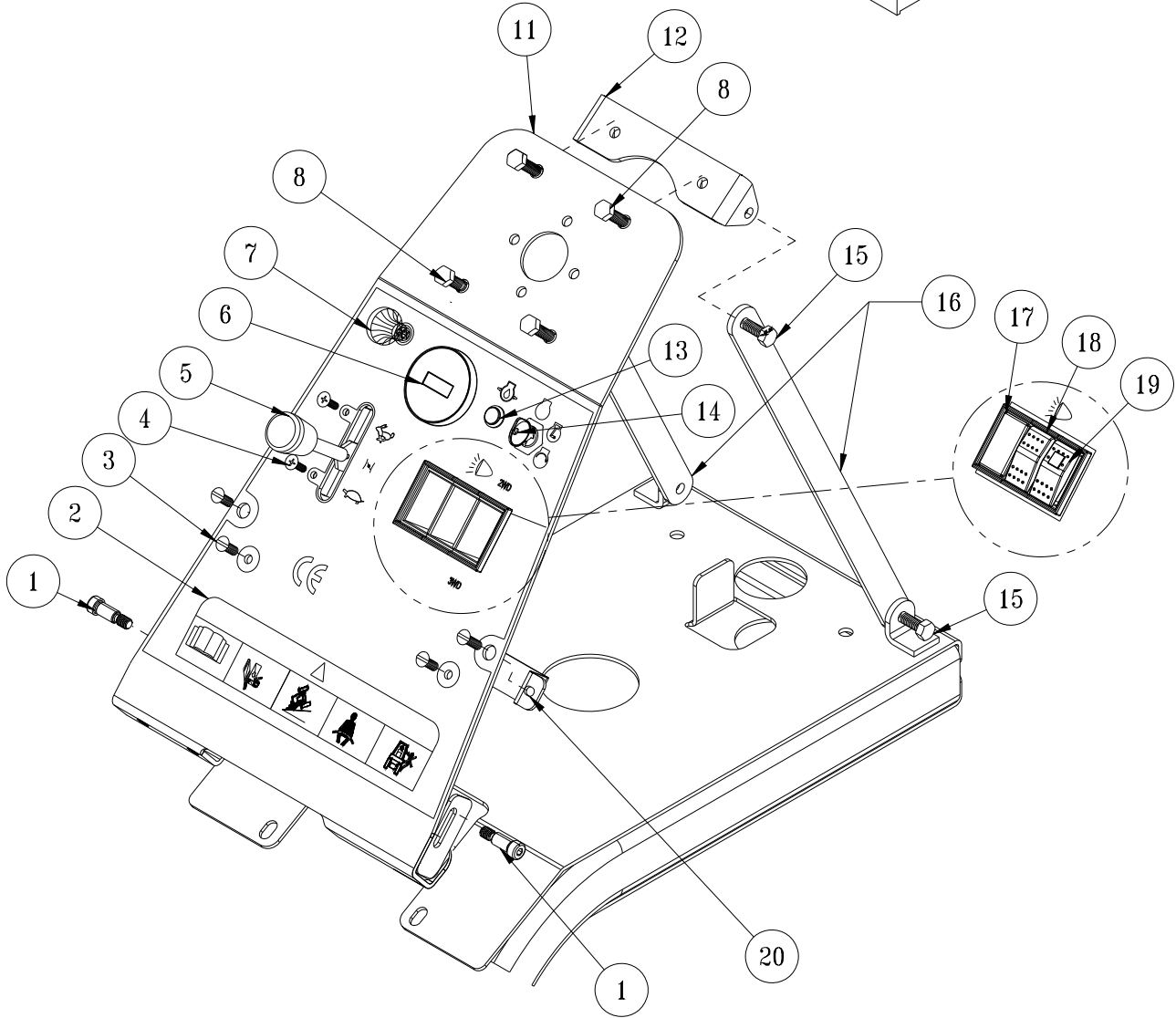
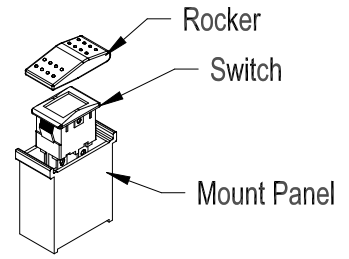

Parts

DASHBOARD PARTS LIST

REF#	PART#	DESCRIPTION	QUANTITY
1	HBSH-38 x 38	Shoulder Bolt, $\frac{3}{8}$ UNC x $\frac{3}{8}$	2
	HNSQ-516-18	Square Nut, $\frac{5}{16}$ -18	2
2	45-095	Decal, Dash Panel	1
3	HSTP-14-20-075	Phillips Machine Screw, $\frac{1}{4}$ - 20 x $\frac{3}{4}$	4
	HNFL-14-20	Flange Whiz-loc Nut, $\frac{1}{4}$ - 20	4
4	HSM-10-32-063	Machine Screw, #10 - 32 x $\frac{5}{8}$	2
	HNFL-10-32	Flange Whiz-loc Nut, #10 -32	2
5	45-118	Throttle Cable	1
6	12-804	Hour Meter	1
7	80-020	Choke Cable	1
8	HB-38-16-100	Hex Bolt, $\frac{3}{8}$ - 16 x 1	4
11	45-090	Dash Board	1
12	45-078	Top Mount Bracket	1
13	50-359	Warning Indicator Light	1
14	13-488	Ignition Switch assembly	1
	76-310	Key Set	1
15	HBFL-516-18-075	Flange Bolt, $\frac{5}{16}$ - 18 x $\frac{3}{4}$	4
	HNFL-516-18	Flange Whiz-loc Nut, $\frac{5}{16}$ -18	4
16	45-124	Dash Brace	2
17	15-725	Mount Panel End	2
	15-730	Mount Panel Plug (1 on 3WD and 2 on 2WD)	1
18	15-729	Mount Panel Middle	1
	15-727	Rocker , No light	1
	15-782	Non lighted Switch, On-None-Off	1
19	15-725	Mount Panel End	1
	15-726	Lighted Switch	1
	15-731	Rocker , Amber	1
20	45-049	Wire Retainer	1
NS	45-042	Wire Harness	1

FOOT PEDAL LINKAGE DRAWING

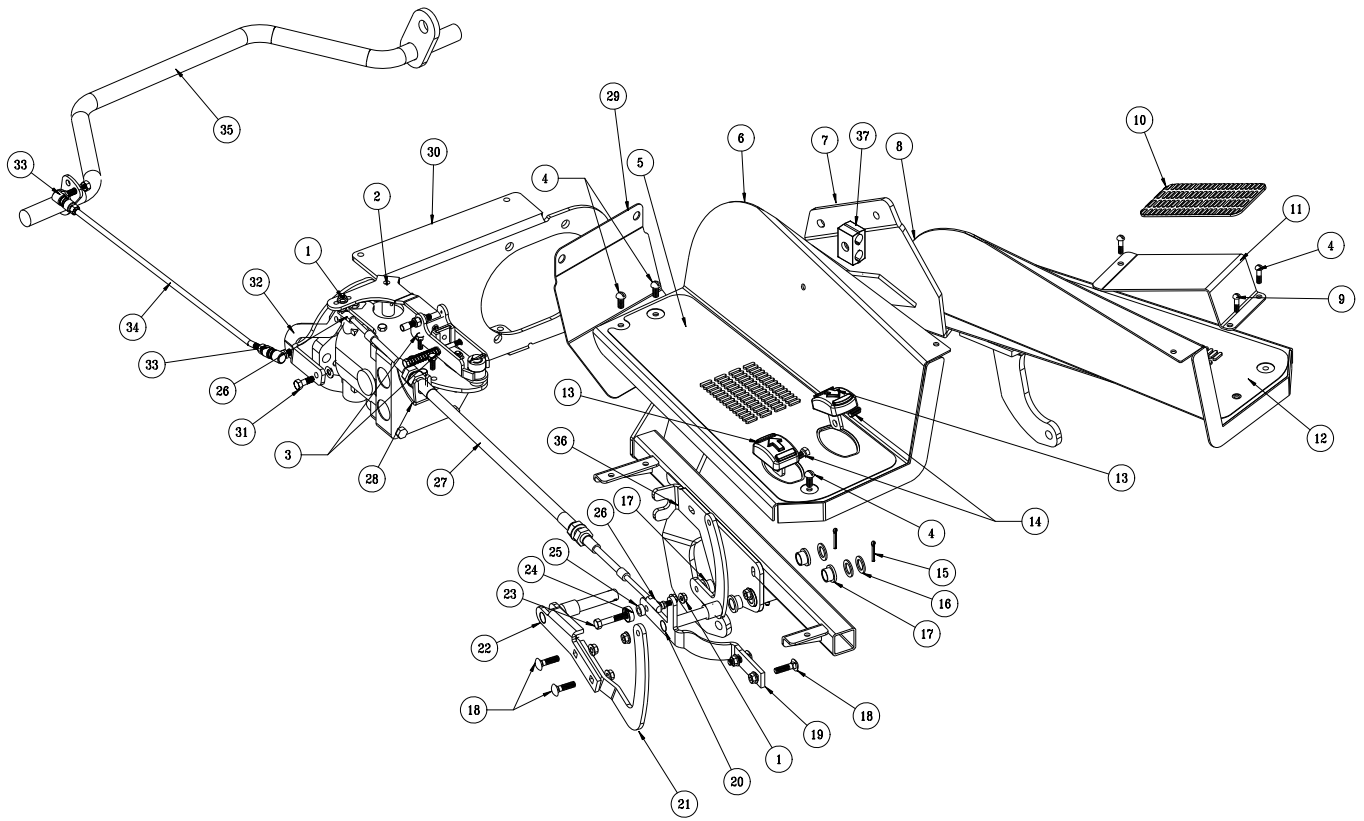

Parts

FOOT PEDAL LINKAGE PARTS LIST

REF#	PART#	DESCRIPTION	QUANTITY
1	HN-14-28	Hex Nut, 1/4 NF	2
2	45-369	Swash Arm	1
3	HB-516-18-075	Hex Bolt, 5/16 - 18 x 3/4	2
	HNFL-516-18	Flange Whiz-Loc Nut, 5/16 - 18	2
4	HSTP-516-18-075	Truss Head Pan Screw, 5/16 - 18 x 3/4	6
	HNFL-516-18	Flange Whiz-Loc Nut, 5/16 - 18	6
5	45-063	RH Floor Mat	1
6	45-098	RH Floorboard	1
7	45-145	Floorboard Frame	1
8	45-099	LH Floorboard	1
9	HSTP-14-20-100	Truss Head Pan Screw, 1/4 -20 x 1	1
	HNFL-14-20	Flange Whiz-Loc Nut, 1/4 - 20	1
10	45-132	Foot Rest Grip	1
11	45-047	Foot Rest Plate	1
12	45-064	LH Floor Mat	1
13	45-022	Molded Foot Pedal	2
14	HBFL-516-18-075	Flange Whiz-Loc Bolt, 5/16 - 18 x 3/4	2
	HNFL-516-18	Flange Whiz-Loc Nut, 5/16 - 18	2
15	HP-18-100	Cotter Pin, 1/8 x 1	2
16	HMB-58-14	Machine Bushing, 5/8 x 10GA	3
17	76-128	Flange Bushing (part of floor board frame)	4
18	HBCL-516-18-075	Carriage Hex Bolt, 5/16 - 18 x 3/4	4
	HNFL-516-18	Flange Whiz-Loc Nut, 5/16 - 18	4
19	45-133	Forward Pedal Arm	1
20	45-083	Forward Pedal Brace	1
21	45-134	Reverse Pedal Arm	1
22	45-084	Reverse Pedal Brace	1
23	HB-516-18-125	Hex Bolt, 5/16 -18 x 1 1/4	1
	HNFL-516-18	Flange Whiz-Loc Nut, 5/16- 18	1
24	8-601	Micro Ball Bearing	1
25	8-622	Spacer	1
26	8-701	Ball Joint, 1/4 NF	2
27	42-063	Push Pull Cable	1
28	45-094	Cable Bracket	1
29	45-146	Dirt Guard	1
30	45-045	Pump Mount	1
31	HB-516-18-100	Hex Bolt, 5/16 - 18 x 1	1
	HNTL-516-18	Nylon Lock Nut, 5/16 - 18	1
	HW-516	Flat Washer, 5/16	2
32	45-449	Speed Boss Arm	1
33	18-387	Quick Disconnect Ball Joints	2
	HN-516-24	Hex Nut, 5/16 - 24	4
34	45-409	Speed Boss Rod	1
35	45-114	Lift Bar	1
36	45-147	Pedal Mount	1
37	18-370	Hose Clamp	1

FUEL TANK PARTS LIST

REF#	PART#	DESCRIPTION	QUANTITY
1*	26-055	Shut-Off Valve	1
2*	26-054	Bushing Insert	1
3	42-833	Fuel Tank (includes all * items)	1
4*	42-814-02	Cap	1
	42-814-01	Tether	1
5*	42-814-05	Vent Check Valve	1
6	HBFL-516-18-075	Flange Whiz-Loc Bolt, $\frac{5}{16}$ - 18 x $\frac{3}{4}$	2
	HNFL-516-18	Flange Whiz-Loc Nut, $\frac{5}{16}$ - 18	2
7	45-123	Rake Holder	1
8	HB-516-18-200	Hex Bolt, $\frac{5}{16}$ - 18 x 2	6
	HW-516	Flat Washer, $\frac{5}{16}$	6
	HNFL-516-18	Flange Whiz-Loc Nut, $\frac{5}{16}$ - 18	6
9	HB-516-18-075	Hex Bolt, $\frac{5}{16}$ - 18 x $\frac{3}{4}$	2
	HNFL-516-18	Flange Whiz-Loc Nut, $\frac{5}{16}$ - 18	2
10	45-086	RH Rear Fender Bracket	1
11	45-402	Seat Belt Brace	1
12	13-729	2-Bank Hydraulic Valve	1
	78-551	Handles	2
13	45-407	RH Fender Support	1
14	HB-516-18-200	Hex Bolt, $\frac{5}{16}$ - 18 x 2	2
15	45-405	Upper Valve Mount	1.
16	45-406	Lower Valve Mount	1
17	HNFL-516-18	Flange Whiz-Loc Nut, $\frac{5}{16}$ - 18	2
18	8-688	Carbon Canister Mount	1
	HSTP-516-18-075	Phillips Machine Screw, $\frac{5}{16}$ - 18 x $\frac{3}{4}$	2
	HNFL-516-18	Flange Whiz-Loc Nut, $\frac{5}{16}$ - 18	2
19	8-738	Carbon Canister	1
20	HB-14-20-075	Hex Bolt, $\frac{1}{4}$ - 20 x $\frac{3}{4}$	2
	HW-14	Flat Washer, $\frac{1}{4}$	2
	HWL-14	Lock Washer, $\frac{1}{4}$	2
21	45-053	RH Tank Plate	1
22	45-178	RH Tank Mount	1
23*	42-814-04	Top Draw	1
24*	42-814-03	Fuel Level Gauge	1
A	8800-18	$\frac{1}{4}$ " Fuel Hose x 18" (Vent Check Valve to Carbon Canister)	1
B	8800-48	$\frac{1}{4}$ " Fuel Hose x 48" (Top Draw to Fuel Filter To Engine)	1
	18-186	Hose Clamp	2
	9024	Clamp Cover	1
C	9025-34	$\frac{5}{16}$ " Fuel Hose x 34" (Carbon Canister to engine)	1
NS	42-814-06	Rollover Valve Grommet	
	42-814-07	Top Draw Grommet	
	20-692-03	Gauge Grommet	

OIL TANK DRAWING

Parts

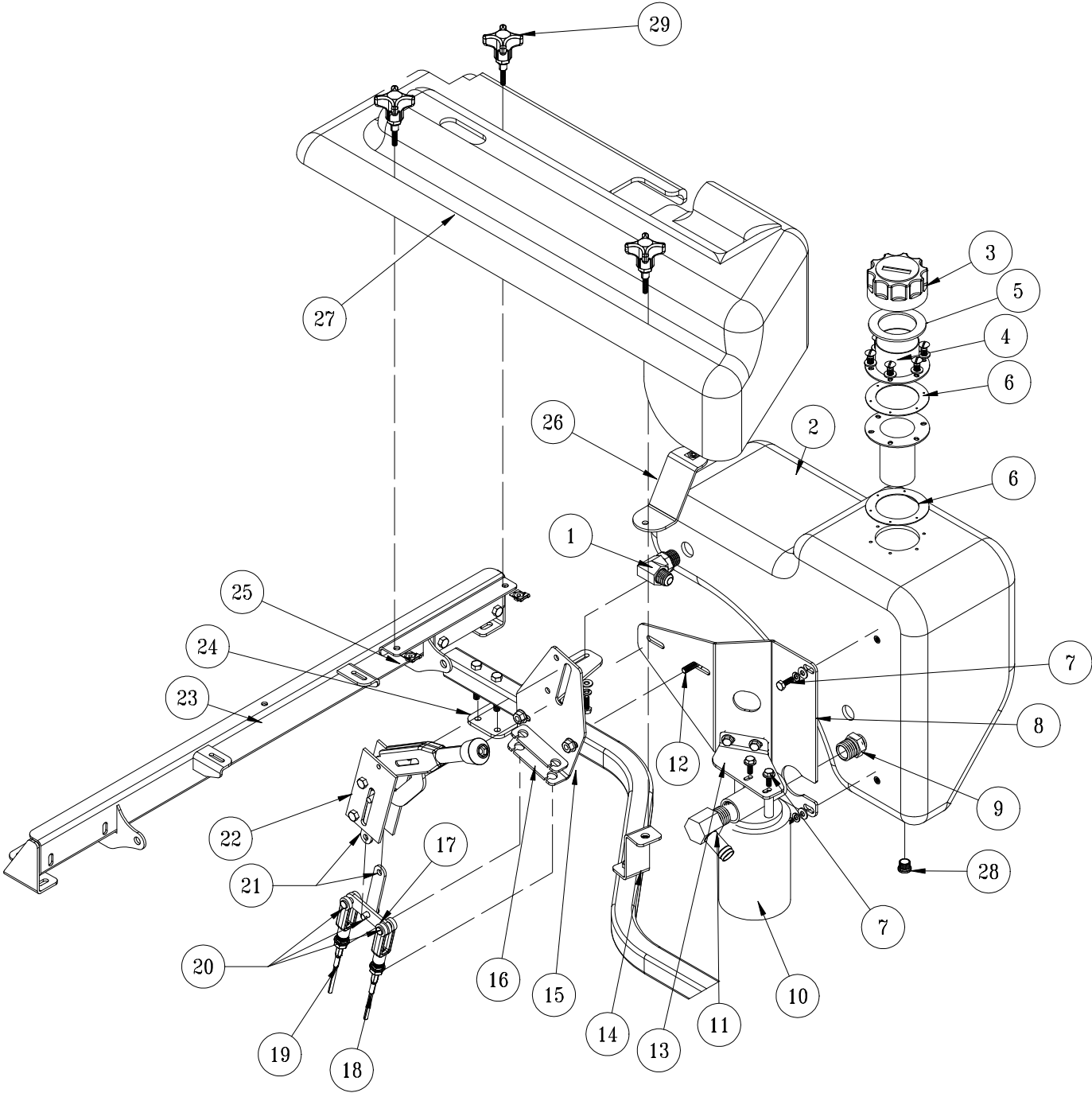

OIL TANK PARTS LIST

REF#	PART#	DESCRIPTION	QUANTITY
1	23-189	90° Adjustable Elbow	1
2	42-005	Oil Tank	1
3	13-747	Filler Breather	1
5	13-586-01	Cap Gasket	1
4	13-586-03	Neck	1
	HSM-8-32-050	Machine Screw, #8 - 32 x 1/2	6
	HWS-8	Star Washer, #8	6
6	13-586-02	Bottom Gasket	2
7	HB-14-20-075	Hex Bolt, 1/4 - 20 x 3/4	6
	HW-14	Flat Washer, 1/4	6
	HWL-14	Lock Washer, 1/4	6
8	45-054	LH Tank Plate	1
9	18-459	O-ring Fitting	1
10	23-006	Oil Filter	1
	23-031	Replacement Filter Element	1
11	18-460	90° Barb Fitting	1
12	HB-516-18-200	Hex Bolt, 5/16 - 18 x 2	2
	HW-516	Flat Washer, 5/16	2
	HNFL-516-18	Flange Whiz-Loc Nut, 5/16 - 18	2
13	45-056	Oil Filter Brace	1
	HB-14-20-075	Hex Bolt, 1/4 - 20 x 3/4	2
	HW-14	Flat Washer, 1/4	2
	HNFL-14-20	Flange Whiz-Loc Nut, 1/4 - 20	2
14	45-408	LH Front Fender Mount	1
	HB-516-18-200	Hex Bolt, 5/16 - 18 x 2	1
	HNFL-516-18	Flange Whiz-Loc Nut, 5/16 - 18	1
15	45-420	Park Brake Mount	1
16	45-070	Cable Mount Spacer	1
17	45-075	Equalizer Link	1
18	45-108	Brake Cable (to RH brake)	1
19	45-407	Brake Cable (to LH Brake)	1
20	HCP-516-100	Clevis Pin, 5/16 x 1	3
	HP-18-075	Cotter Pin, 1/8 x 3/4	3
21	45-074	Park Brake Link	2
22	60-106	Park Brake Lever	1
23	45-402	Brace Plate	1
24	45-178	LH Tank Mount	1
	HB-516-18-175	Hex Bolt, 5/16 - 18 x 1 3/4	2
	HW-516	Flat Washer, 5/16	2
	HNFL-516-18	Flange Whiz-Loc Nut, 5/16 - 18	2
25	45-113	LH Rear Fender Mount	1
	78-274	Cage Nuts	2
26	45-384	LH Front Fender Brace	1
	78-274	Cage Nuts	1
27	45-044	LH Front Fender	1
28	23-126	#6 Plug	1
29	45-411	Knob Handle	3

BELTS AND PULLEYS DRAWING

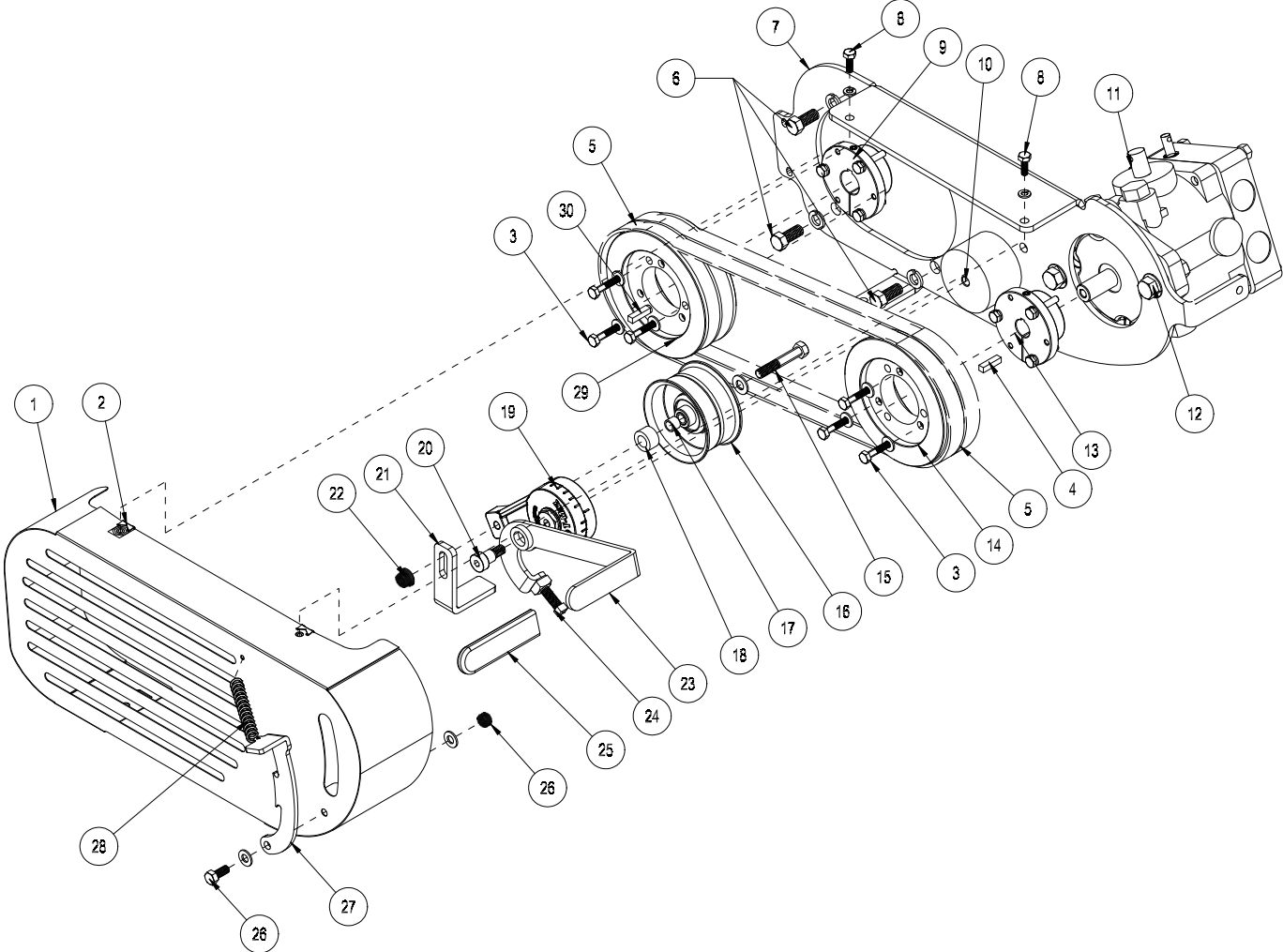

Parts

BELTS AND PULLEYS PARTS LIST

REF#	PART#	DESCRIPTION	QUANTITY
1	42-353	Belt Guard	1
2	78-274	Cage Nut	3
3	HB-14-20-125	Hex Bolt, $\frac{1}{4}$ - 20 x $1\frac{1}{4}$	6
	HW-14	Lock Washer, $\frac{1}{4}$	6
4	HKSQ-14-150	Machine Key, $\frac{1}{4}$ x $\frac{1}{4}$ x $1\frac{1}{2}$	2
5	42-359	Belt	2
6	HB-716-14-100	Hex Bolt, $\frac{7}{16}$ - 14 x 1	4
	HWL-716	Lock Washer, $\frac{7}{16}$	4
7	45-045	Pump Mount	1
8	HB-14-20-075	Hex Bolt, $\frac{1}{4}$ -20 x $\frac{3}{4}$	3
	HWL-14	Lock Washer, $\frac{1}{4}$	3
9	42-245	Hub, 1"	1
10	42-361	Tensioner Spacer	1
	HB-38-16-275	Hex Bolt, $\frac{3}{8}$ -16 x $2\frac{3}{4}$	1
	HWL-38	Lock Washer, $\frac{3}{8}$	1
11	45-373	Pump	1
12	HB-12-13-175	Socket Screw, $\frac{1}{2}$ - 13 x $1\frac{3}{4}$	2
	HNTL-12-13	Nylon Lock Nut, $\frac{1}{2}$ - 13	2
13	45-376	Hub, $\frac{3}{4}$ "	1
14	45-374	Pulley, 6"	1
15	HB-38-16-275	Hex Bolt, $\frac{3}{8}$ -16 x $2\frac{3}{4}$	1
	HW-38	Flat Washer, $\frac{3}{8}$	1
16	42-358	Idler Pulley	1
17		Oilite Bushing Part of Idler Pulley	1
18	16-990	Spacer	1
19	42-327	Tensioner	1
20	42-352	Hex Socket Head shoulder Screw	1
21	42-357	Belt Stop	1
22	HNFL-38-16	Flange Whiz-Loc Nut, $\frac{3}{8}$ -16	1
23	42-355	Clutch Handle	1
24	HSSQ-38-16-150	Socket Head Square Screw, $\frac{3}{8}$ - 16 x $1\frac{1}{2}$	1
	HN-38-16	Hex Nut, $\frac{3}{8}$ - 16	1
25	15-020	Grip	1
26	HB-516-18-075	Hex Bolt, $\frac{5}{16}$ -18 x $\frac{3}{4}$	1
	HW-516	Flat Washer, $\frac{5}{16}$	1
	HNTL-516-18	Nylon Lock Nut, $\frac{5}{16}$ -18	1
27	42-356	Lock Handle	1
28	16-046	Spring	1
29	45-375	Pulley, 5"	1

18HP ENGINE DRAWING

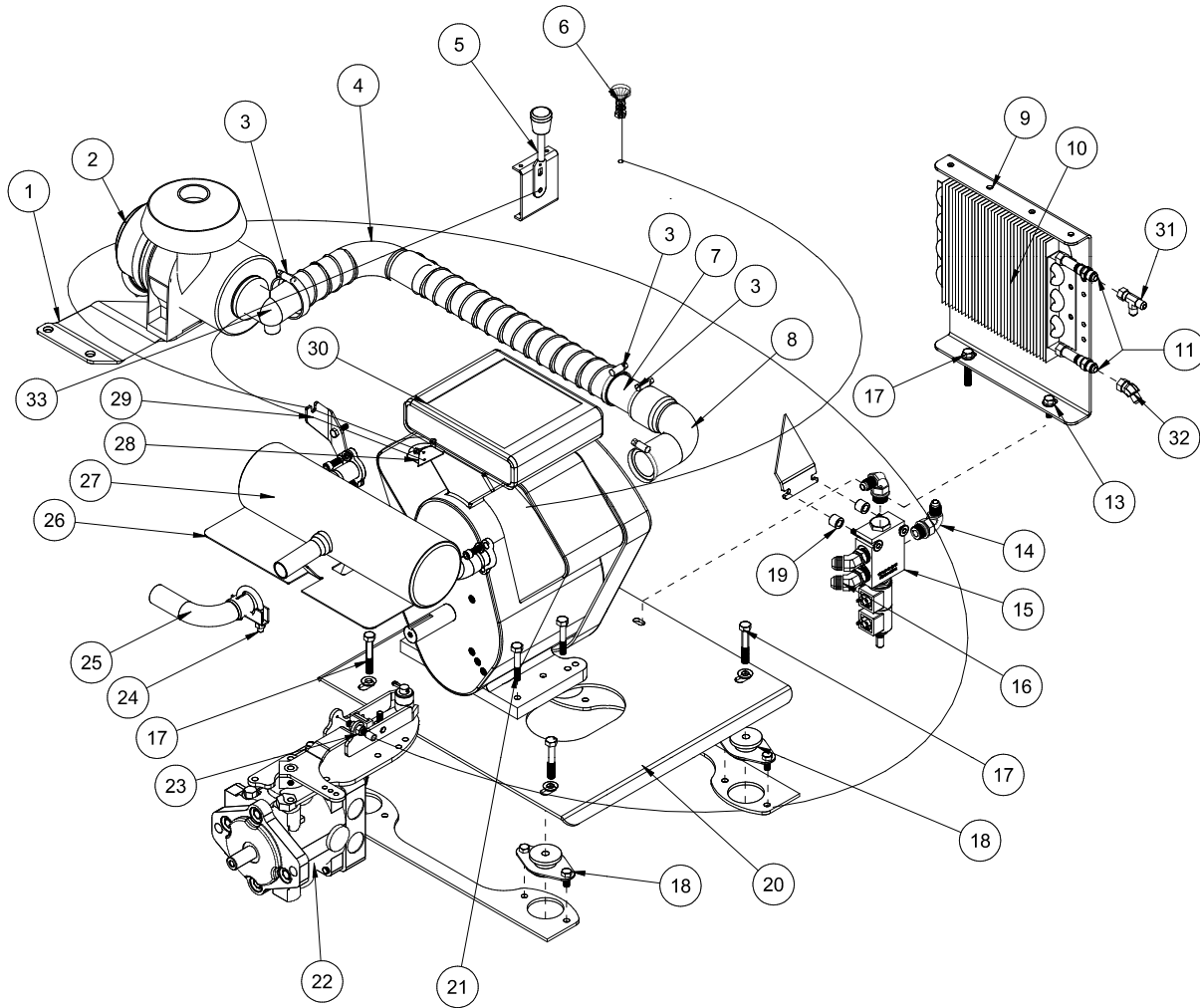

Parts

Cyclonic air cleaner 42-834

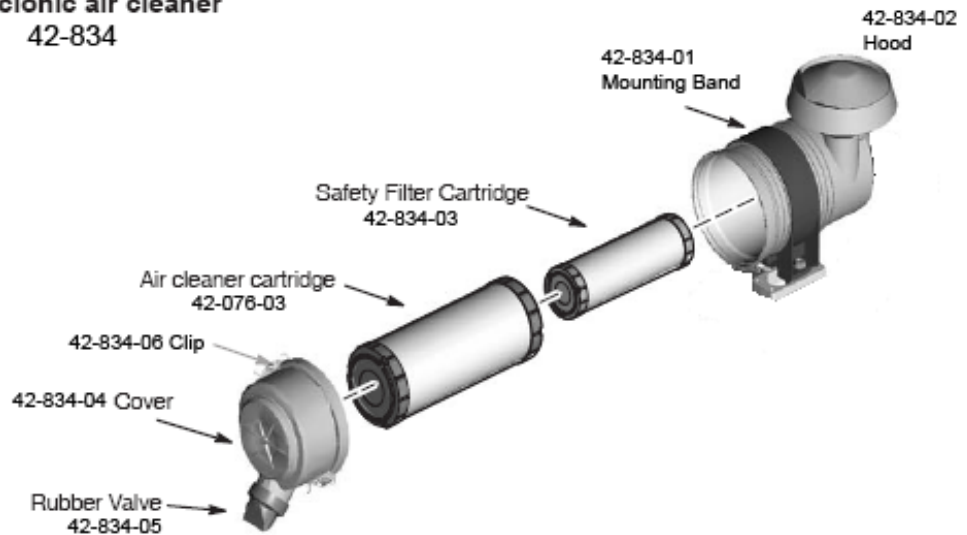

18HP ENGINE PARTS LIST

REF #	PART #	DESCRIPTION	QUANTITY
1	45-058	Air Filter Mount	1
2	42-834	Air Cleaner	1
	42-076-03	Replacement Filter	1
	42-834-03	Safety Filter	1
3	18-116	Hose Clamp	4
4	8959-26	Flex Hose x 26"	1
5	45-118	Throttle Cable	1
6	80-020	Choke Cable	1
7	42-776	Air Cleaner Hose Sleeve	1
8	27-113	Rubber Elbow	1
9	45-383	Cooler Mount	1
10	45-382	Cooler	1
11	18-410	Adapter	2
13	HB-516-18-075	Hex Bolt, $\frac{5}{16}$ - 18 - $\frac{3}{4}$	1
	HW-516	Flat Washer, $\frac{5}{16}$	1
	HNFL-516-18	Flange Whiz-Loc Nut, $\frac{5}{16}$ - 18	1
14	18-185	90° O-ring Fittings	2
15	42-118	Electric On/Off Valve	1
	42-118-01	Coil	1
	HB-14-20-250	Hex Bolt, $\frac{1}{4}$ - 20 x 2 $\frac{1}{2}$	2
	HW-14	Flat Washer, $\frac{1}{4}$	2
	HNFL-14-20	Flange Whiz-loc Nut, $\frac{1}{4}$ - 20	2
16	18-266	45° O-ring Fittings	2
17	HB-38-16-225	Hex Bolt, $\frac{3}{8}$ - 16 x 2 $\frac{1}{4}$	4
	HW-38	Flat Washer, $\frac{3}{8}$	4
	HNTL-38-16	Nylon Lock Nut, $\frac{3}{8}$ - 16	4
18	20-618	Rubber Insulators	4
	HB-516-18-075	Hex Bolt, $\frac{5}{16}$ - 18 x $\frac{3}{4}$	8
	HNFL-516-18	Flange Whiz-Loc Nut, $\frac{5}{16}$ - 18	8
19	45-154	Spacer	1
20	45-046	Engine Plate	1
21	HB-516-18-175	Hex Bolt, $\frac{5}{16}$ - 18 x 1 $\frac{3}{4}$	4
	HNFL-516-18	Flange Whiz-Loc Nut, $\frac{5}{16}$ - 18	4
22	45-373	Pump	1
23	17-151	Cable	1
	17-624	Conduit	1
24	45-161	Clamp	1
25	45-162	Tail Pipe	1
26	42-601	Heat Shield	1
	HB-716-14-100	Hex Bolt, $\frac{7}{16}$ - 14 x 1	4
	HWL-716	Lock Washer, $\frac{7}{16}$	4
27	45-158	Muffler	1
	18-222	Hose Clamp	2
28	45-111	Throttle Adapter	1
	21-161	Wire Block	1
29	45-077	Cable Bracket	1
30	43-024	Engine B&S 18HP	1
	18-462	Drain Valve	1
31	18-190	Tee	1
32	18-214	45° Elbow	1
33	42-834-07	Cobra Elbow	1

3WD PUMP DRAWING

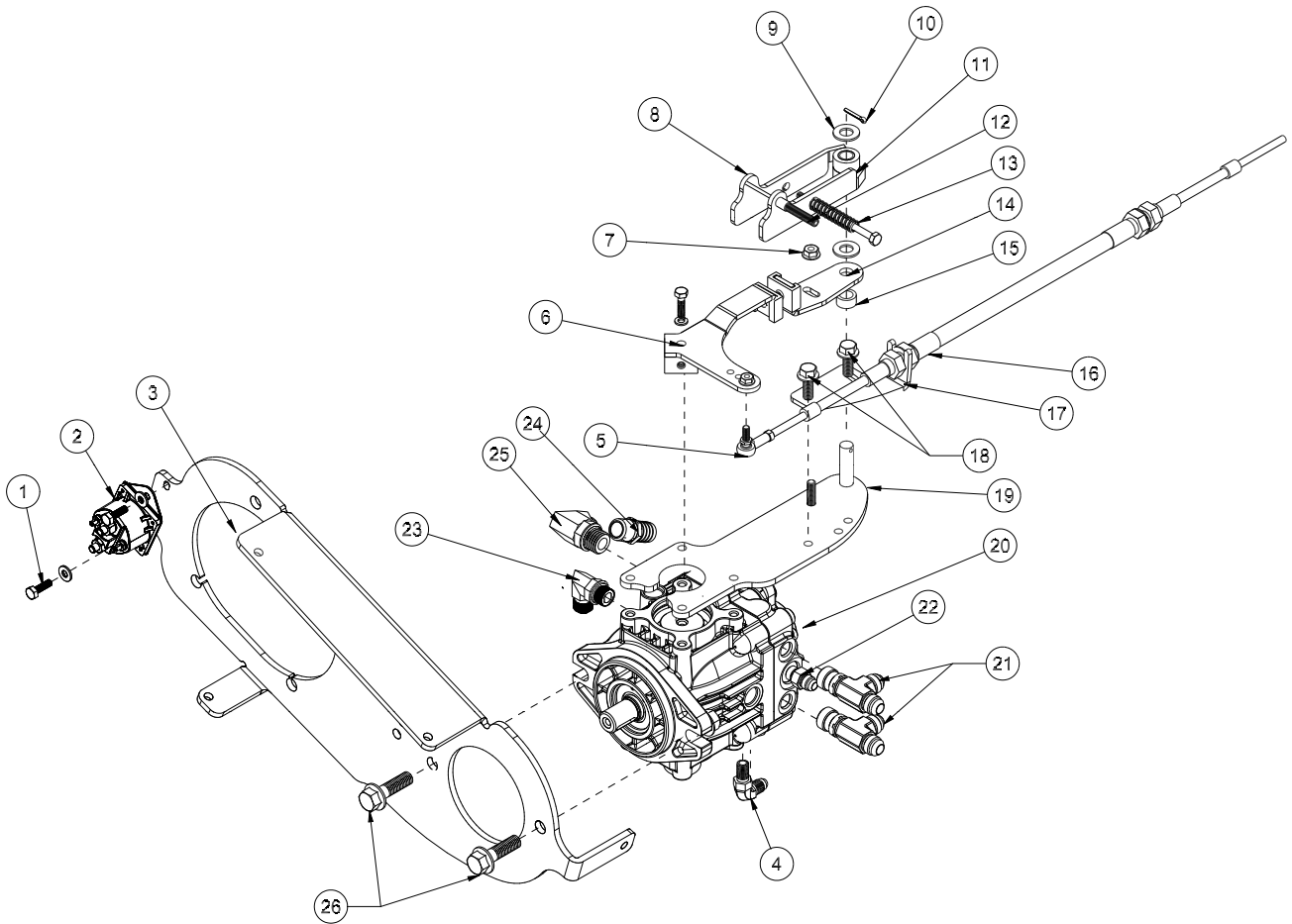

Parts

3WD PUMP PARTS LIST

REF #	PART #	DESCRIPTION	QUANTITY
1	HB-516-18-075	Hex Bolt, $\frac{5}{16}$ - 18 x $\frac{3}{4}$	2
	HW-516	Flat Washer, $\frac{5}{16}$	2
	HNFL-516-18	Flange Whiz Nut, $\frac{5}{16}$ - 18	2
2	13-750	Solenoid w/ Connector	1
3	45-045	Pump Mount	1
4	18-168	Elbow, $\frac{3}{8}$ Straight Thread	1
5	8-701	Ball Joint, $\frac{1}{4}$ NF	1
	HN-14-28	Hex Nut, $\frac{1}{4}$ - 28	1
6	45-369	Swash Arm	1
	8946-1	Wear Strip (part of 45-369)	1
	HRS-316-050	Rivet (part of 45-369)	1
	HRW-316	Rivet Washer	1
	HNTL-516-18	Lock Nut, $\frac{5}{16}$ - 18	1
7	HW-516	Flat Washer, $\frac{5}{16}$	1
	45-368	Top Centering Arm	1
8	18-434	Bushing (part of 45-368)	1
9	HMB-12-14	Machine Bushing, $\frac{1}{2}$ x 14GA	as needed
10	HP-332-075	Cotter Pin, $\frac{3}{32}$ x $\frac{3}{4}$	1
11	45-367	Bottom Centering Arm	1
	18-434	Bushing (part of 45-367)	1
12	17-151	Cable	1
	17-624	Conduit	1
13	42-832	Compression Spring	1
	HB-14-20-400	Hex Bolt, $\frac{1}{4}$ - 20 x 4	1
	HNTL-14-20	Nylon Lock Nut, $\frac{1}{4}$ - 20	1
	HW-14	Flat Washer, $\frac{1}{2}$	1
	45-327	Creep Arm	1
14	8946-1	Wear Strip (part of 45-327)	1
	HRS-316-050	Rivet (part of 45-327)	1
	HRW-316	Rivet Washer	1
15	42-836	Spacer	1
16	42-063	Push Pull Cable	1
17	45-094	Cable Bracket	1
18	HB-38-16-100	Hex Bolt, $\frac{3}{8}$ - 16 x 1	2
	HNTL-38-16	Nylon Lock Nut, $\frac{3}{8}$ - 16	2
19	45-370	Control Mount	1
20	45-373	Piston Pump	1
21	18-477	Tee	2
22	18-169	Adapter	1
23	18-174	Straight Thread Elbow	1
24	18-133	Barb Fitting	1
25	23-127	Elbow	1
26	HB-12-13-175	Hex Bolt, $\frac{1}{2}$ - 13 x $1\frac{3}{4}$	2
	HW-12	Flat Washer, $\frac{1}{2}$	2
	HNTL-12-13	Lock Nut, $\frac{1}{2}$ - 13	2

REAR AXLE DRAWING

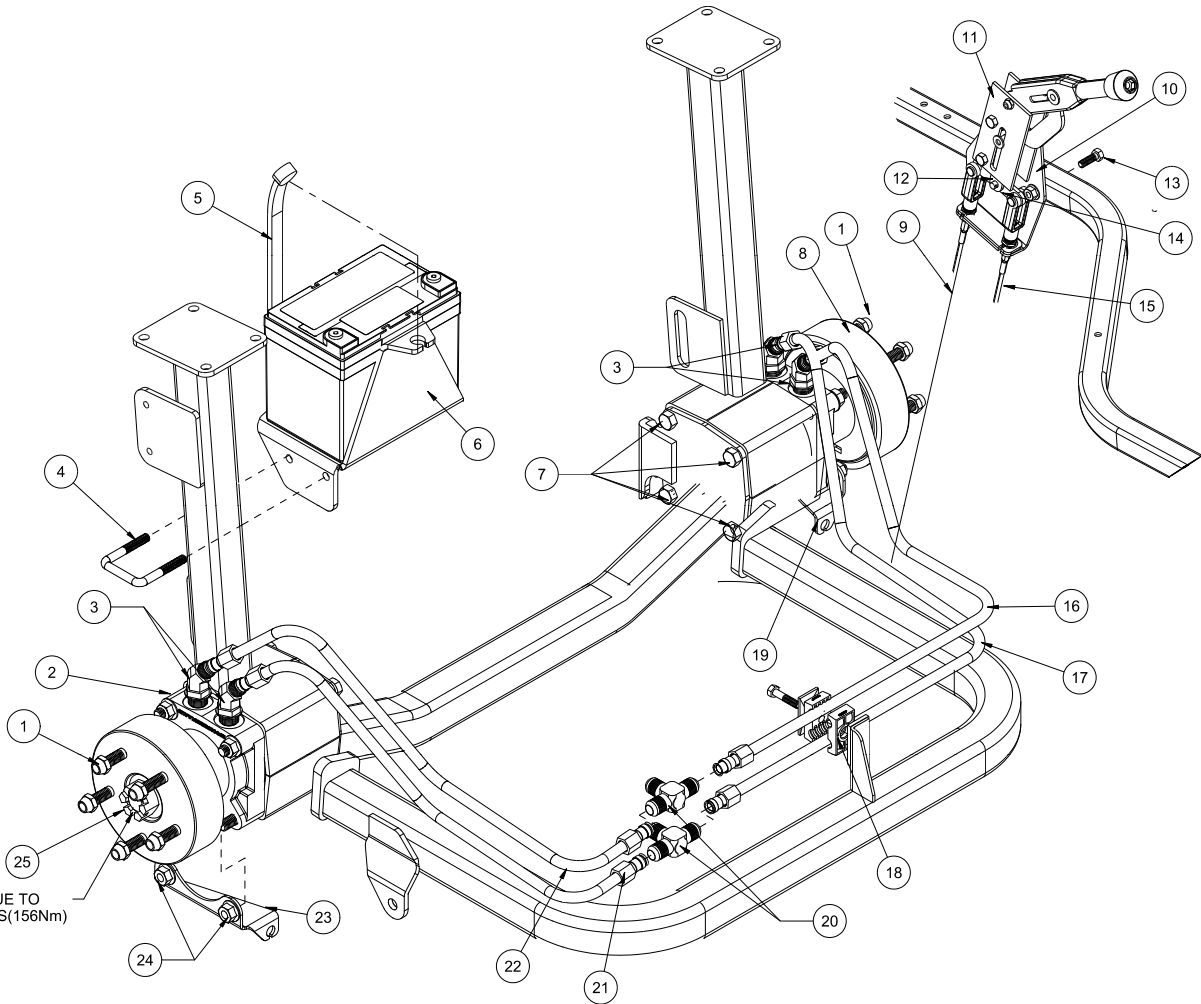

TORQUE TO
120 FT/LBS(156Nm)

Parts

REAR AXLE PARTS LIST

REF#	PART#	DESCRIPTION	QUANTITY
1	HNL-12-20	Lug Nut, 1/2 - 20	10
	45-065-01	Wheel Stud	10
2	45-065	RH Brake Assembly w/ Wheel Motor	1
3	18-383	45° Elbow	4
4	17-537	Square U-Hex Bolt	1
5	8-603	Battery Strap	1
6	45-059	Battery Tray	1
7	HB-12-13-700	Hex Bolt, 1/2 - 13 x 7	8
8	45-066	LH Brake Assembly w/ Wheel Motor	1
9	45-107	LH Brake Cable	1
10	45-420	Park Brake Mount	1
11	60-106	Park Brake Lever	1
12	45-074	Park Brake Link	2
13	HB-516-18-100	Hex Bolt, 5/16 - 18 x 1	2
	HW-516	Flat Washer, 5/16	2
	HNFL-516-18	Flange Whiz-Loc Nut, 5/16 - 18	2
14	45-075	Equalizer	1
	HCP-516-100	Clevis Pin, 5/16 x 1	2
	HP-18-100	Cotter Pin, 1/8 x 1	2
15	45-108	RH Brake Cable	1
16	45-039	LH Upper Hydraulic Tube	1
17	45-038	LH Lower Hydraulic Tube	1
18	45-069	Twin Pipe Clamp	1
19	45-080	LH Brake Cable Mount	1
20	18-170	Tee	2
21	45-040	RH Lower Hydraulic Tube	1
22	45-041	RH Upper Hydraulic Tube	1
23	45-079	RH Brake Cable Mount	1
24	HNFL-12-13	Flange Whiz-Loc Nut, 1/2 - 13	8
25	14-265	Nut, 1-8 (part of wheel motor)	2
NS	43-241-01	Brake Assembly only (replacement part)	
NS	45-065-02	Brake Drum (replacement part)	

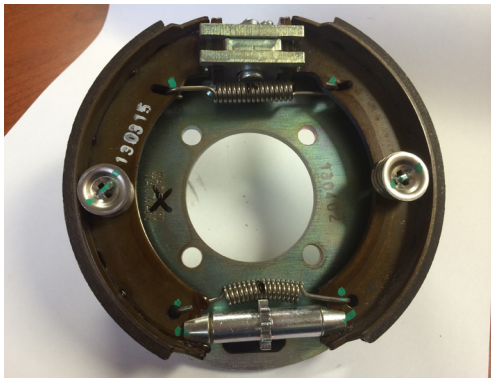

43-241-01 Brake Assembly

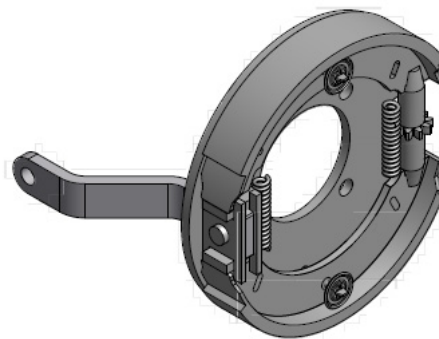

REAR RAKE LIFT DRAWING

Parts

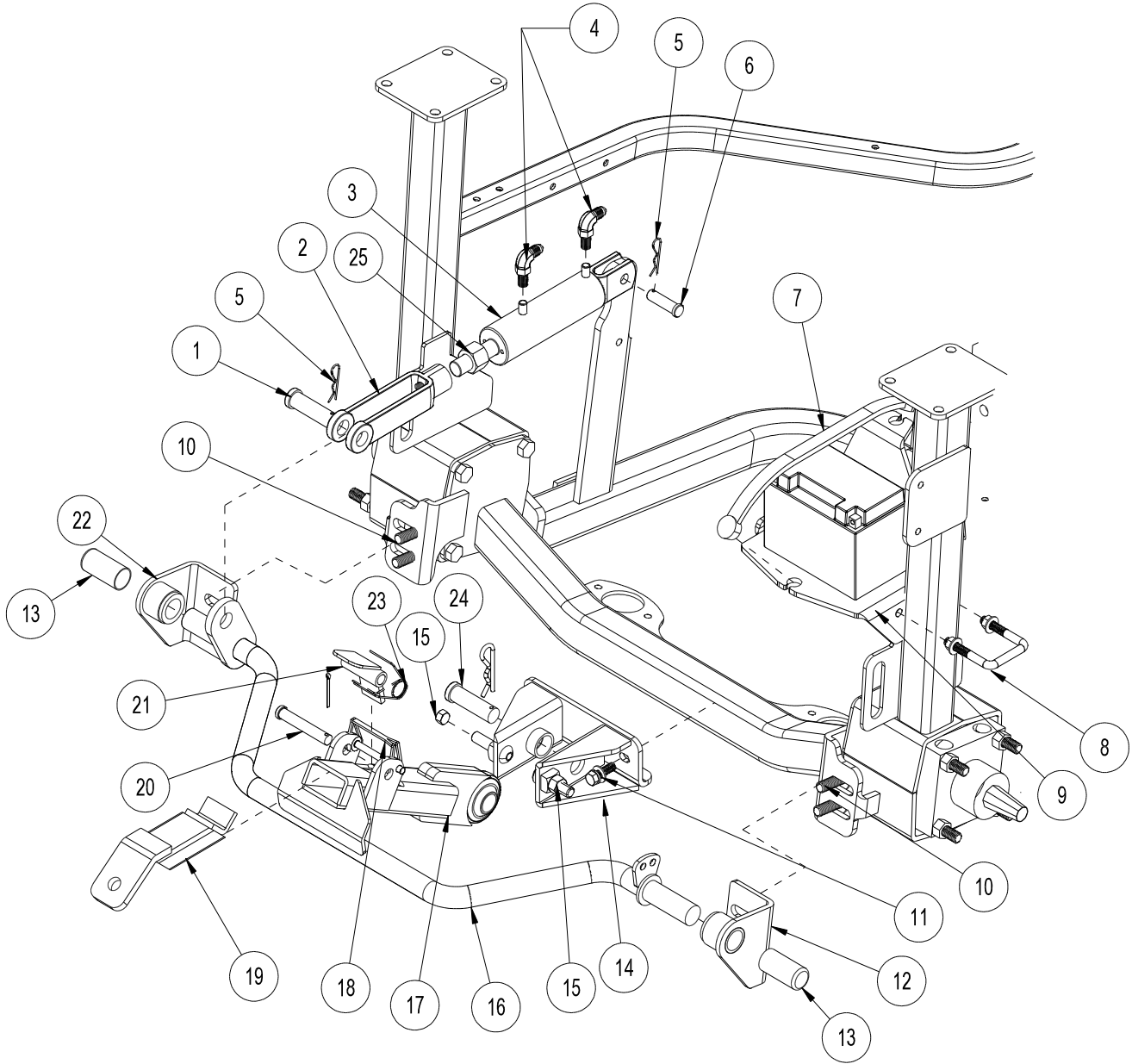

REAR RAKE LIFT PARTS LIST

REF#	PART#	DESCRIPTION	QUANTITY
1	HCP-34-200	Clevis Pin, $\frac{3}{4}$ x 2	1
2	42-040	Lift Linkage	1
3	43-150	Hydraulic Cylinder	1
	43-150-01	Seal Kit	1
4	18-168	90° Elbow	2
5	HHP-18	Bridge Pin, $\frac{1}{8}$	2
6	HCP-12-150	Clevis Pin, $\frac{1}{2}$ - $1\frac{1}{2}$	1
7	8-603	Battery Strap	1
8	17-537	Square U-Hex Bolt	1
9	45-059	Battery Tray	1
10	HB-12-13-125	Hex Bolt, $\frac{1}{2}$ - 12 x $1\frac{1}{4}$	4
	HW-12	Flat Washer, $\frac{1}{2}$	4
	HNFL-12-13	Flange Whiz-Loc Nut, $\frac{1}{2}$ - 12	4
11	HB-38-24-100	Hex Bolt, $\frac{3}{8}$ - 24 x 1	2
	HW-38	Flat Washer, $\frac{3}{8}$	2
	HWL-38	Lock Washer, $\frac{3}{8}$	2
12	34-220	Pivot Bracket - RH	1
	33-086	Flange Bushing (part of 34-220)	1
	HG-14-28-180	Grease Fitting, $\frac{1}{4}$ - 28 x 180°	1
13	15-019	Rubber Grip	2
14	43-140	Frame Mount	1
15	HSSHB-12-13-200	Button Socket Head Cap Screw	2
	HN-12-13	Nut, $\frac{1}{2}$ -13	2
	HNCL-12-13	Center Nylon Lock Nut, $\frac{1}{2}$ - 13	2
16	45-114	Lift Bar	1
17	43-141	Lift Arm	1
18	25-382	Lock Pin	1
19	43-143	Towing Hitch (OPTIONAL)	1
20	HCP-12-350	Clevis Pin, $\frac{1}{2}$ - $3\frac{1}{2}$	1
	HP-18-100	Cotter Pin, $\frac{1}{8}$ x 1	1
21	43-139	Lock	1
22	34-219	Pivot Bracket - LH	1
	33-086	Flange Bushing (part of 34-219)	1
	HG-14-28-180	Grease Fitting, $\frac{1}{4}$ - 28 x 180°	1
23	43-136	Torsion Spring	1
24	HCP-78-350	Clevis Pin, $\frac{7}{8}$ x $3\frac{1}{2}$	1
	HHP-.177	Bridge Pin, .177 x $3\frac{3}{4}$	1
25	HNJ-34-16	Jam Nut, $\frac{3}{4}$ - 16	1

CENTER LIFT DRAWING

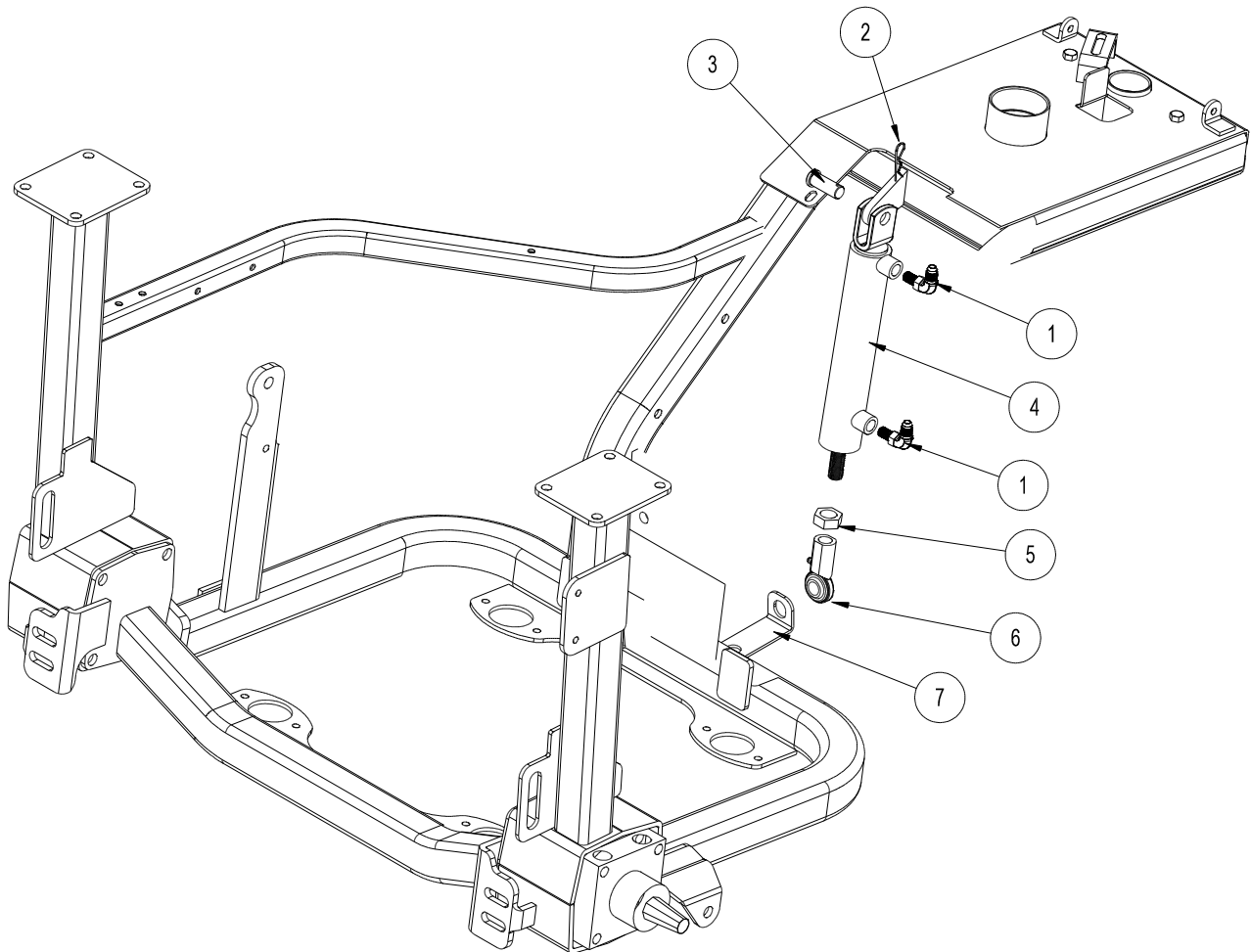

Parts

REF#	PART #	DESCRIPTION	QUANTITY
1	18-168	90° Elbow	2
2	HHP-18	Bridge Pin $\frac{1}{8}$	1
3	HCP-58-150	Clevis Pin $\frac{5}{8}$ - $1\frac{1}{2}$	1
4	10-554	Hydraulic Cylinder	1
	14-529	Seal Kit	1
5	HNJ-58-18	Jam Nut $\frac{5}{8}$ - 18	1
6	18-154	Rod End	1
	HG-14-28-180	Grease Fitting $\frac{1}{4}$ - 28 x 180°	1
7	45-153	Center Ram Holder	1

13-729 2-BANK HYDRAULIC VALVE

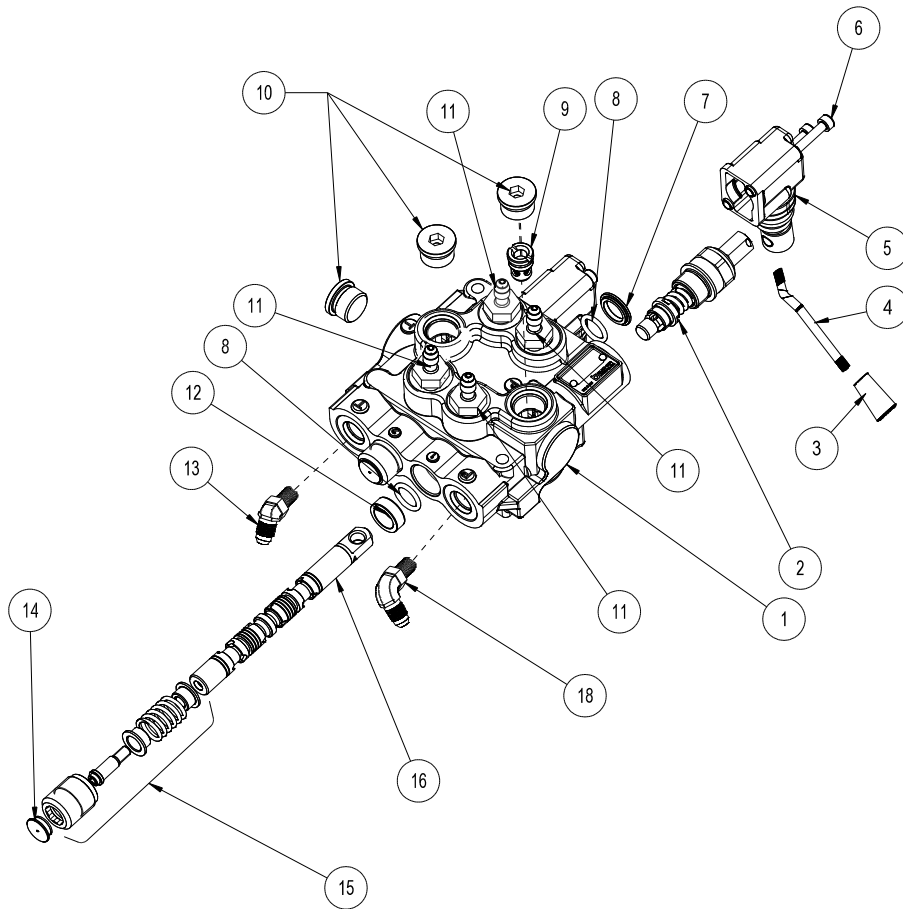

REF #	PART #	DESCRIPTION	QUANTITY
1*	78-415-01	Body (complete with spacer and check valve)	1
2*	78-415-02	Spool HDM10	1
3	78-417-01	Tapered Knob	2
4	78-551	Offset Bent Handle	2
5*	78-415-09	Lever Group HDS11	2
6*	78-415-10	Metric Socket Screw M5 x .8 x 45	4
7*	78-415-04	Flanged Washer HDM10	2
8*	78-415-03	O-Ring Seal	4
9*	78-415-12	Check Valve Assembly HDM12	1
10*	78-415-13	$\frac{3}{4}$ - 16 SAE 8 Screw Plug	3
11	18-169	Adapter $\frac{1}{4}$ - $\frac{3}{8}$ SAE	4
12*	78-415-05	Spacer	2
13	18-188	45° Elbow	1
14*	78-415-08	Plug	2
15	78-415-11	Positioner	2
16*	78-415-06	A Type Spool HDS11	2
18	18-168	Elbow	1

* 13-729 2 – Bank Hydraulic Valve (includes all * items)

45-067 FRONT WHEEL MOTOR

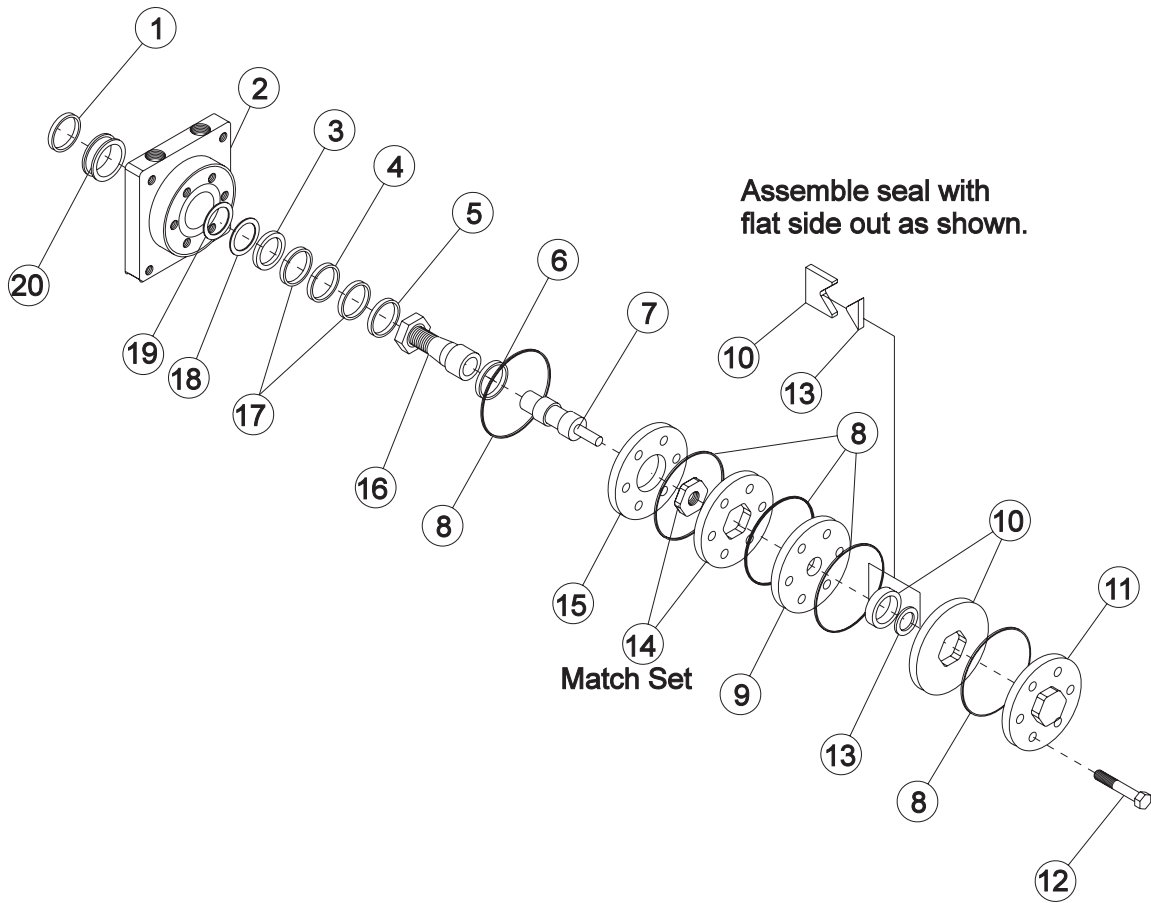

Parts

REF#	PART#	DESCRIPTION	QUANTITY
1*		Water & Dirt Seal	1
2		Service Housing Assembly	1
3*		Inner Seal	1
4	13-032-27	Thrust Bearing	1
5	13-032-28	Inner Bearing	1
6	13-032-29	Thrust Bearing	1
7	13-032-30	Drive Link	1
8*		Ring Seal	5
9	13-032-31	Manifold	1
10	13-032-32	Commutator Assembly (matched set)	1
11		End Cover	1
12	14-134	Bolt	7
13*		Commutator Seal (matches with #10)	1
14	13-032-34	Rotor Set (matched set)	1
15	14-399-06	Plate Wear	1
16	13-032-36	Coupling Shaft	1
	HWK-516-100	Woodruff Key $\frac{5}{16}$ x 1	1
	14-265	Nut 1 - 20	1
17	13-032-37	Thrust Washer	2
18*		Backup Washer	1
19*		Backup Washer	1
20	13-032-38	Outer Bearing	1
*	14-080	Seal Kit	1

REAR WHEEL MOTOR (7.5 C.I.) DRAWING

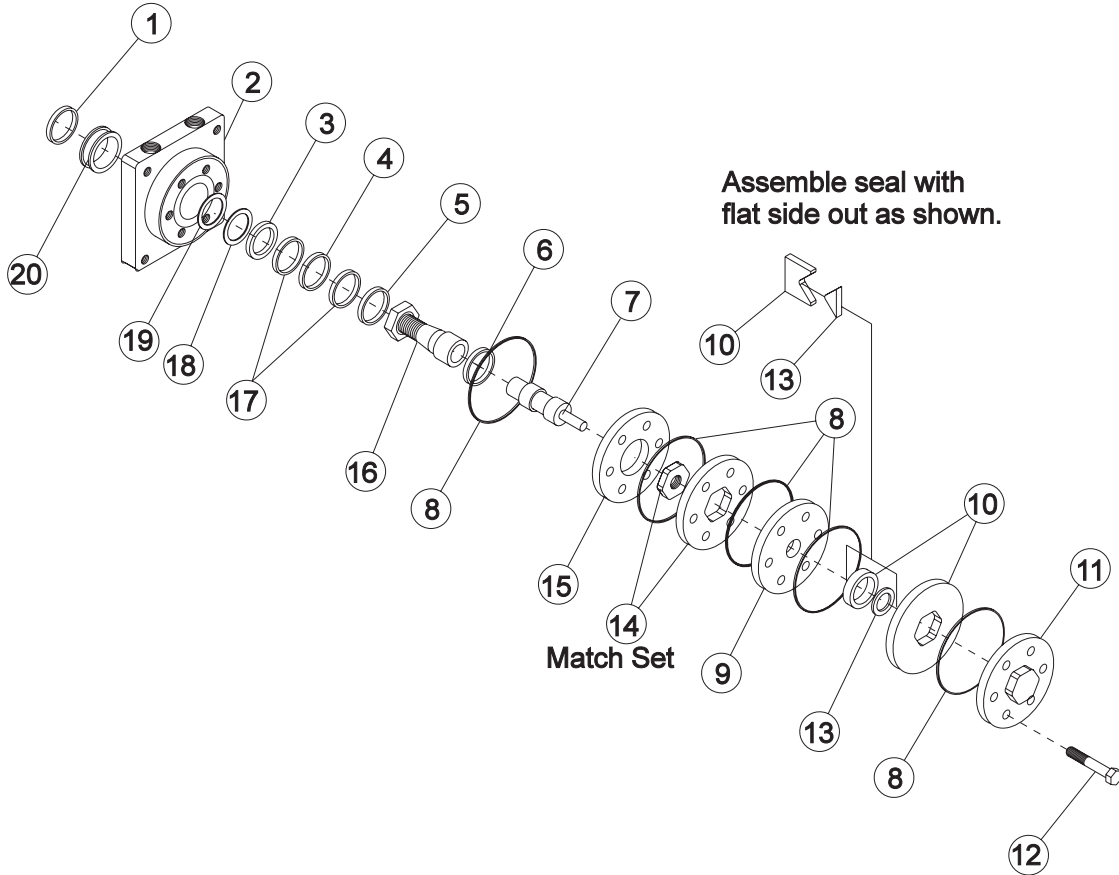

REF#	PART#	DESCRIPTION	QUANTITY
1*		Water & Dirt Seal	1
2		Service Housing Assembly (Includes Ref 4, 5, 17(2 req'd) and 20)	1
3*		Inner Seal	1
4	13-032-27	Thrust Bearing	1
5	13-032-28	Inner Bearing	1
6	13-032-29	Thrust Bearing	1
7	13-615-03	Drive Link	1
8*		Ring Seal	5
9	13-032-31	Manifold	1
10	13-032-32	Commutator Assembly (matched set)	1
11		End Cover	1
12	13-615-01	Bolt	7
13*		Commutator Seal (matches with #10)	1
14	13-615-02	Rotor Set (matched set)	1
15	13-032-35	Plate Wear	1
16	13-615-04	Coupling Shaft	1
	HWK-516-100	Woodruff Key $5/16 \times 1$	1
	14-265	Nut 1 - 20	1
17	13-032-37	Thrust Washer	2
18*		Backup Washer	1
19*		Backup Washer	1
20	13-032-38	Outer Bearing	1
*	14-080	Seal Kit	1

45-373 PISTON PUMP PARTS LIST

REF#	PART#	DESCRIPTION	QUANTITY
1	45-373-02	Ball Bearing	1
2	45-373-03	Retaining Ring	1
3	45-373-04	Retaining Ring	2
4*		Lip Seal	1
5	45-373-05	Journal Bearing Carrier Assembly	1
6	45-373-06	Retaining Ring	1
7	45-373-07	Needle Bearing	1
8	45-373-08	End Cap	1
9	45-373-09	Plug Assembly	2
10	45-373-10	By-Pass Valve Assembly	1
11	45-373-11	Charge Pump Housing	1
12	45-373-12	Gerotor Assembly	1
13*		O-ring	1
14*		O-ring	1
15	45-373-13	Valve Plate CCW	1
16	45-373-14	Cylinder Block kit	1
17	45-373-15	Thrust Plate	1
18	45-373-16	Swash Plate, Axial Offset	1
19*		Gasket	1
20	45-373-17	Journal Bearing Carrier Assembly	1
21	45-373-19	Housing	1
22	45-373-18	Pump Shaft	1
*	45-373-01	Overhaul Kit	

34-103 ORBITAL DRAWING

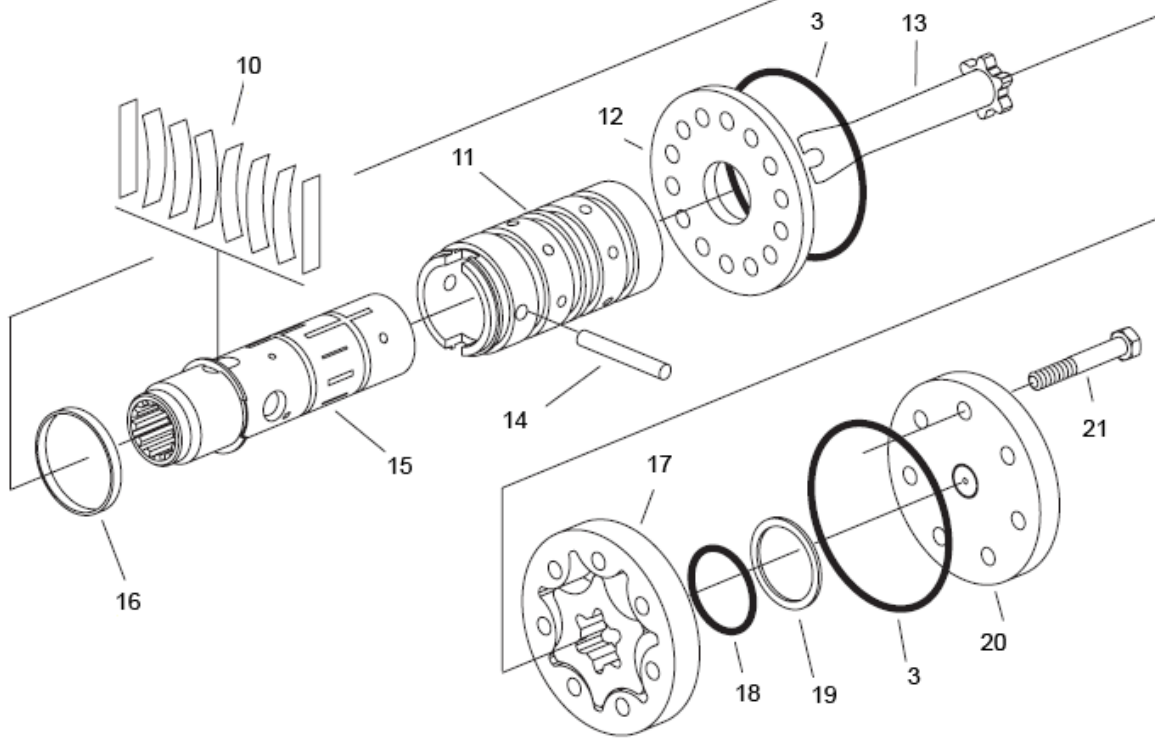
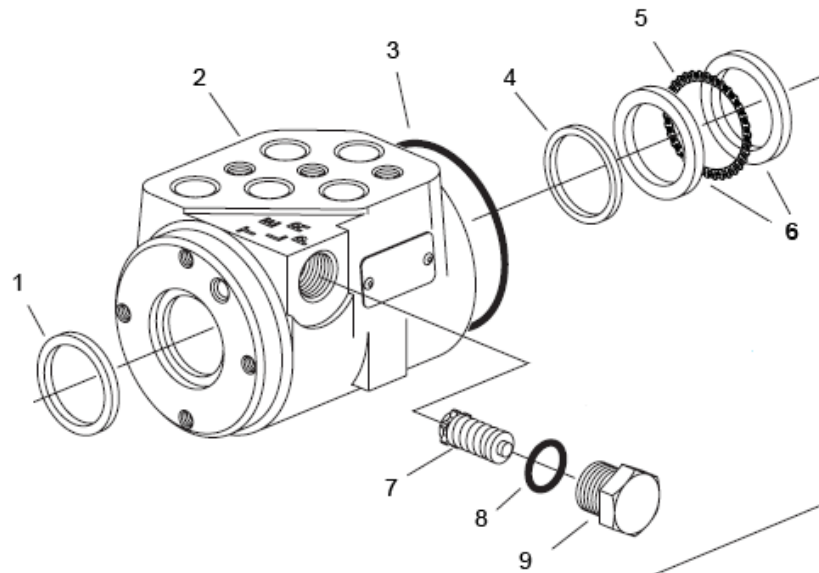

Parts

34-103 ORBITAL PARTS LIST

REF #	PART #	DESCRIPTION	QUANTITY
1**		Dust Seal	1
2		Housing	1
3**		O-Ring Seal	3
4**		Quad Seal	1
5	10-576-03	Thrust Bearing	1
6	10-576-02	Bearing Race	2
7		Manual Steering Relief Valve	1
8**		O-ring	1
9		Plug	1
10‡		Standard Torque Centering Springs	1
11		Sleeve	1
12	15-301-06	Wear Plate	1
13	10-576-01	Drive	1
14	15-301-08	Drive Pin	1
15		Spool	1
16‡		Spring Retaining Ring	1
17	34-103-01	Gerotor	1
18**		O-Ring	1
19**		Seal Ring	1
20	15-301-03	End Cap	1
21	10-576-06	Cap Screw	7
**	15-301-01	Seal Kit	1
‡	15-301-15	Centering Spring Kit	1

15-301 ORBITAL SPECIFICATIONS

Inlet Relief Valve Setting	1020 psi (70 bar)
Nominal Flow	3 gpm (11lpm)
Displacement	6.1 cu. in/ R (100 cu cm/R)
Check Valve for Manual Steering	Yes
Return Pressure Rating	145 psi (10 bar) Maximum
Fluid	SAE 10W-40 API Service SJ or higher Motor Oil
Ports	⁹ / ₁₆ - 18 SAE O-Ring 4 Ports

DECAL LIST

This is a list of decals located on the Sand Star. Part number, description and location will help in reordering decals.

REF#	PART#	DESCRIPTION	QTY
1	45-095	Decal, Dash Panel	1
2	27-077	Decal, Round Smithco	1
3	51-184	Decal, Park Brake	1
4	25-298	Decal, Warning Hot	1
5	25-277	Decal, Battery	1
6	45-135	Decal, Sand Star III	2
7	25-372	Decal, Smithco Star	1
8	25-286	Decal, Pinch Points	2
9	25-370	Decal, DbA 88	1
10	25-354	Decal, Tire Pressure 5PSI	3
11	25-386	Decal, Lift & Lower	1
12	25-337	Decal, Speed Boss	1
13	25-352	Decal, Bypass Valve	1

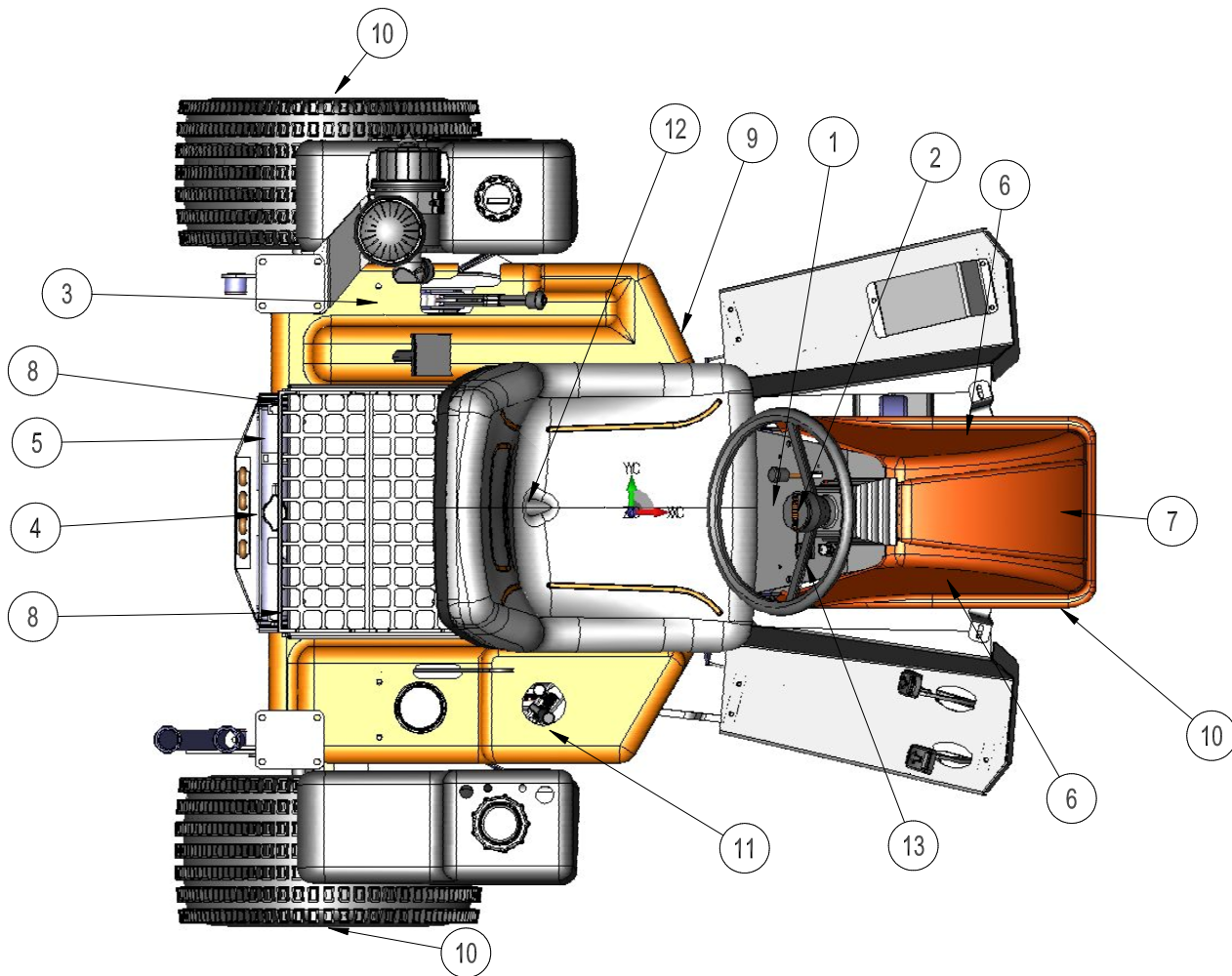

QUICK REFERENCE REPLACEMENT PARTS

REPLACEMENT FILTERS

23-031	Hydraulic Oil Filter	
15-165-01	Air Filter Element with Pre-Cleaner	Briggs and Stratton# 5050
42-076-03	Air Filter Element Fender Mounted	
42-834-03	Safety Filter Element Fender Mounted	
50-403	Fuel Filter	
13-531	Engine Oil Filter	Briggs and Stratton #492932
18-462	Oil Drain Valve	

SEAL KITS

45-373	Variable Pump	
45-373-01	Overhaul Kit	
34-103	Orbitrol	
15-301-01	Seal Kit	
45-065 & 45-066	Wheel Motor (Rear)	
14-080	Seal Kit	
45-067	Wheel Motor (Front)	
14-080	Seal Kit	
13-729	2-Bank Valve	
78-415-03	Seal Kit	
10-554	Hydraulic Cylinder	
14-529	Seal Kit	
43-150	Hydraulic Cylinder (Rake Lift)	
43-150-01	Seal Kit	

FLUIDS

Engine Oil	Refer to Engine Manual
Hydraulic Fluid	SAE 10W-40 API Service SJ or higher Motor Oil

OTHER PARTS

Spark Plugs	RC12YC (Gap 0.030 inch (0.76mm))
48-265	Turf Tire and Wheel

45-004 ROPS

Accessories

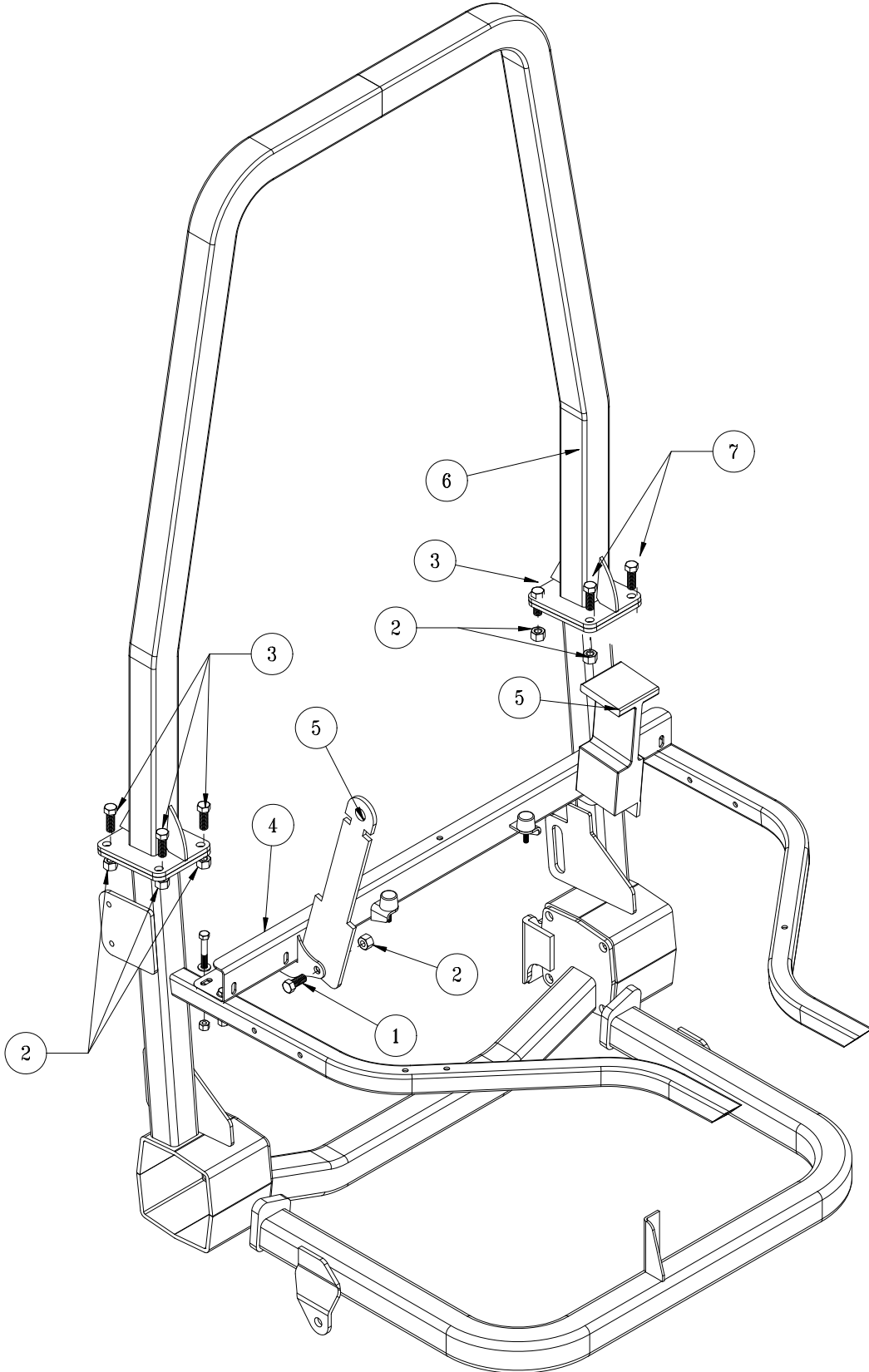

45-004 ROPS

REF#	PART#	DESCRIPTION	QUANTITY
1	HB-716-14-100	Bolt $\frac{7}{16}$ - 14 x 1	2
2	HNTL-716-14	Lock Nut $\frac{7}{16}$ - 14	8
3	HB-716-14-125	Bolt $\frac{7}{16}$ - 14 x $1\frac{1}{4}$	6
4	45-082	Seat Belt Brace	1
5	76-198-03	Seat Belt	1
6	45-060	Roll Bar	1
7	HB-716-14-150	Bolt $\frac{7}{16}$ - 14 x $1\frac{1}{2}$	2

INSTALLATION INSTRUCTIONS

The Following instructions apply to all Sand Star Machines.

1. Line up the mount plate on the roll bar to the square mounting plate by the seat. Mount vertically, **not** leaning back toward the rear of the machine.
2. Place four 1-1/4" bolts in the right mount plate holes and tighten. Place two 1-1/4" bolts on left rear and two 1-1/2" bolts on left front. Bolts are longer in the left front to accommodate remote air cleaner option.
3. If your machine has a remote air cleaner you will have to remove the 2 bolts holding the air filter mount. Place the roll bar on top of the air filter mount. Replace bolts and tighten down.
4. Mount seat belts onto seat belt brace using 1" bolts. The strap goes on the right side and the lock goes on the left side.
5. Tighten all hardware.

ROPs are certified to meet ISO 21299 and restraints meet OSHA 1928.51

45-016 LIGHT KIT DRAWING

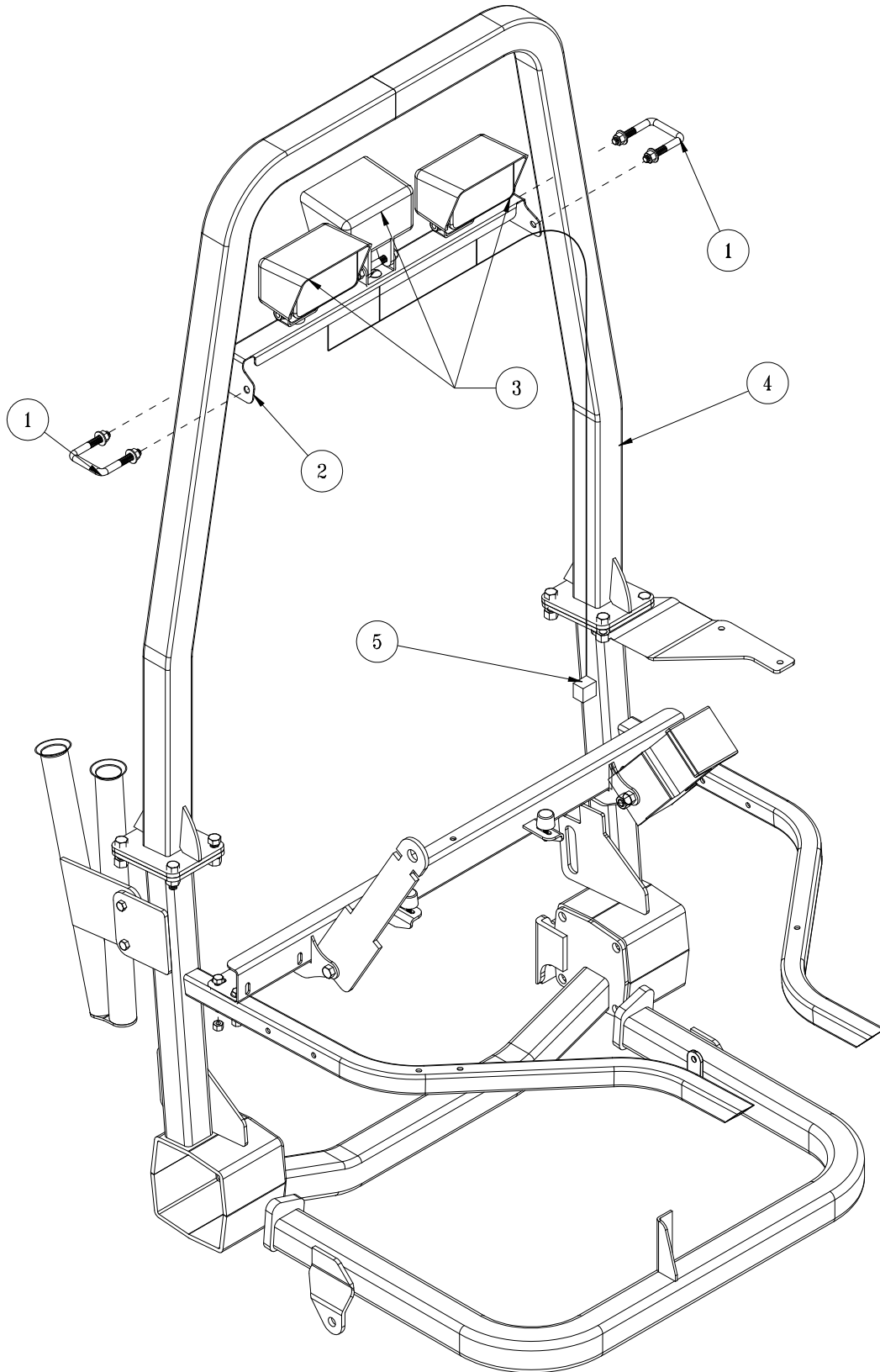

Accessories

45-016 LIGHT KIT PARTS LIST

REF#	PART#	DESCRIPTION	QUANTITY
1	17-537	Square U-bolt	2
2	45-081	Light Bar	1
3	34-201	Light	3
4	45-004	Roll Bar Kit	1
5	43-505	Light Wire Harness	1

INSTALLATION INSTRUCTIONS

45-004-K ROPs Kit is required for Light Kit on all Sand Star Machines.

1. Mount lights to light bar. Outside two facing forwards and center light facing to the rear.
2. Using the square u-bolts, mount light bar assembly to the roll bar.
3. Tighten u-bolts down and make sure light bar and lights are secure.
4. Tighten all hardware.
5. Center toggle switch is wired for lights via the main machine wire harness. The plug for the light wire harness is zip tied to the left rear post (Ref 5). Hook light wire harness from lights to the plug on the left rear post.
6. Use the tie straps provided to secure the light wire harness to the roll bar and the light bar.
7. Test lights.

45-390 LIGHT KIT

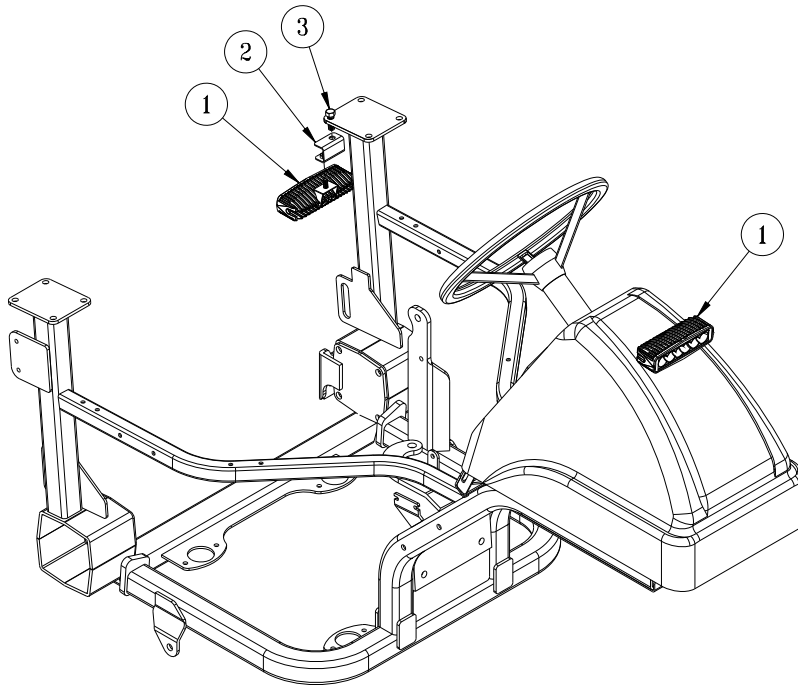

REF#	PART#	DESCRIPTION	QUANTITY
1	10-732	LED Light	2
	45-393	Wire Harness	1
2	45-389	Rear Light Bracket	1
3	HB-716-14-125	Hex Bolt, $\frac{7}{16}$ - 14 x $1\frac{1}{4}$	1
	HNTL-716-14	Lock Nut, $\frac{7}{16}$ - 14	1

INSTALLATION INSTRUCTIONS

1. Remove the nosecone from the machine.
2. Drill a $\text{Ø}5/16$ " hole, centered and 3" down from the top of the nosecone. Drill another $\text{Ø}5/16$ " hole $3/4$ " further down.
3. Install Light Wire Harness on frame with sealed connector at left rear. Connect to main harness and secure using included cable ties.
4. Run the wires through the lower hole. Bolt the light in the top hole. Connect to Light Wire Harness. Replace nosecone.
5. Use the included $\frac{7}{16}$ - 14 Hex Bolt and Lock Nut to mount the Rear Light Bracket to the underside of the Roll Bar mounting plate.
6. Mount the Light to the Light Bracket. Connect wires to Light Wire Harness
7. Test lights.

ACCESSORIES

Front Accessories	A
13-765 Single Bank Valve	2
45-005 40" Aluminum Hydraulic Plow.....	4
45-009 40" Aluminum Manual Plow.....	8
45-019 60" Aluminum Manual Plow	10
45-179 40" Adjustable Manual Plow.....	12
45-180 60" Adjustable Manual Plow.....	14
Center Attachments.....	B
45-014 Weed Cultivator.....	16
45-006 Sand Cultivator.....	17
45-008 Sand Cultivator w/ Spring Tine.....	18
45-012 Construction Leveling Blade.....	19
45-013 Sand Cultivator w/ Castor Wheels.....	20
45-007 Infield Scarifier (vertical blades).....	22
45-011 Infield Scarifier (chisel blades).....	24
45-173 Infield Scarifier (chisel blades/no castors).....	26
45-360 Infield Scarifier (straight blades).....	28
45-195 Grader Blade Kit.....	30
45-177 Nail Drag	32
45-015 Motorized Brush	34
45-175 Adjustable Disc Edger	36
Rear Attachments.....	C
42-391Q 72" Pro-Brush Tournament Rake.....	38
43-392Q 84" Pro-Brush Tournament Rake.....	42
42-130Q 84" Mild Steel Rake	46
42-132Q 72" Mild Steel Rake	50
13-758Q Max Flex Sand Rake	54
45-503 84" Pro Rake	56
45-511 Rubber Flex Rake.....	58
13-740 Brush Attachment.....	60
13-684 Brush Attachment.....	61
13-298Q Fan Rake	62
13-319 Fan Rake Kit.....	63
26-007Q Professional Field Finisher	64
43-002Q Flex Action Field Finisher w/ Brush	65
26-008Q Flex Action Field Finisher	68
43-043 Finishing Brush.....	70
43-008 Drag Mat Kit	71
45-176 Drag Mat Kit w/ Finisher Brush.....	72
45-010 Box Grader	74
42-586Q Green Star RBS Main Frame	76
42-581 Green Star RBS Roller	78
42-585 Green Star RBS Brush	80
42-582 Green Star RBS Spiker	82
43-009 Coco Mat Finisher	84
43-170 Rahn Groomer.....	86
41-501 Typhoon.....	90
Warranty	

Front Attachment

Center Attachment

Rear Attachment

13-765 SINGLE BANK HYDRAULIC VALVE DRAWING

Front Attachment

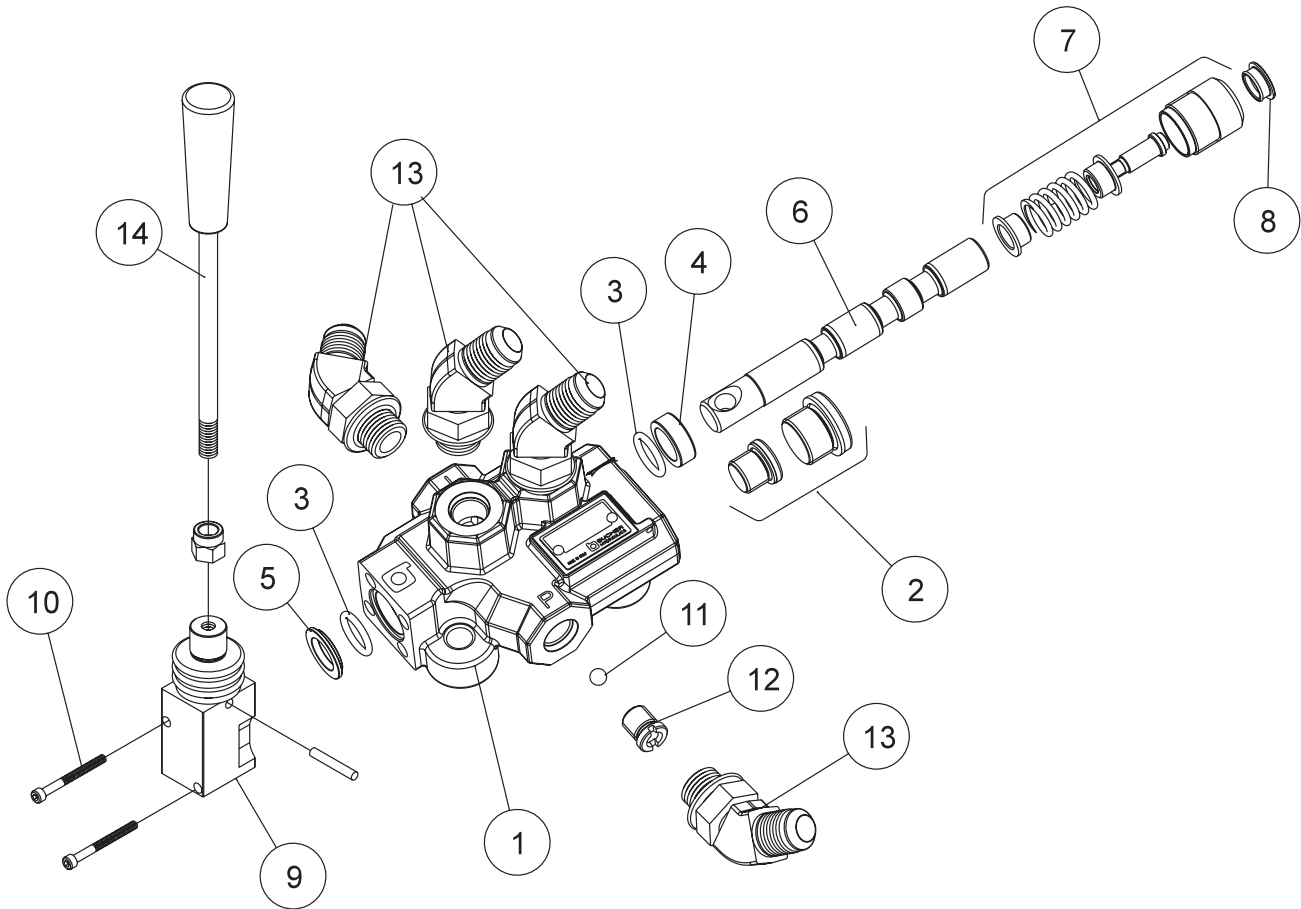

13-765 SINGLE BANK HYDRAULIC VALVE PARTS LIST

REF #	PART #	DESCRIPTION	QUANTITY
1*		Actuator Housing Assembly	1
2*	13-731-02	Valve Plug	1
3*†	78-415-03	O-Ring Seal	2
4*†	78-415-05	Spacer	3
5*	78-415-04	Flanged Washer HDM10	3
6*	13-731-03	Spool	1
7*	78-415-11	Positioner	1
8*	78-415-08	Plug	3
9*	78-415-09	Lever Group HDS11	3
10*	78-415-10	Metric Socket Screw, M5 x .8 x 45	2
11*	13-731-04	1/4" Ball	1
12*†	13-731-05	Check Valve	1
13	18-341	45° Elbow	4
14	78-417	Straight Handle	1
	78-417-01	Tapered Knob	1
*	13-765	Single Bank Hydraulic Valve (includes all * items)	

45-005 HYDRAULIC SAND PLOW DRAWING

Front Attachment

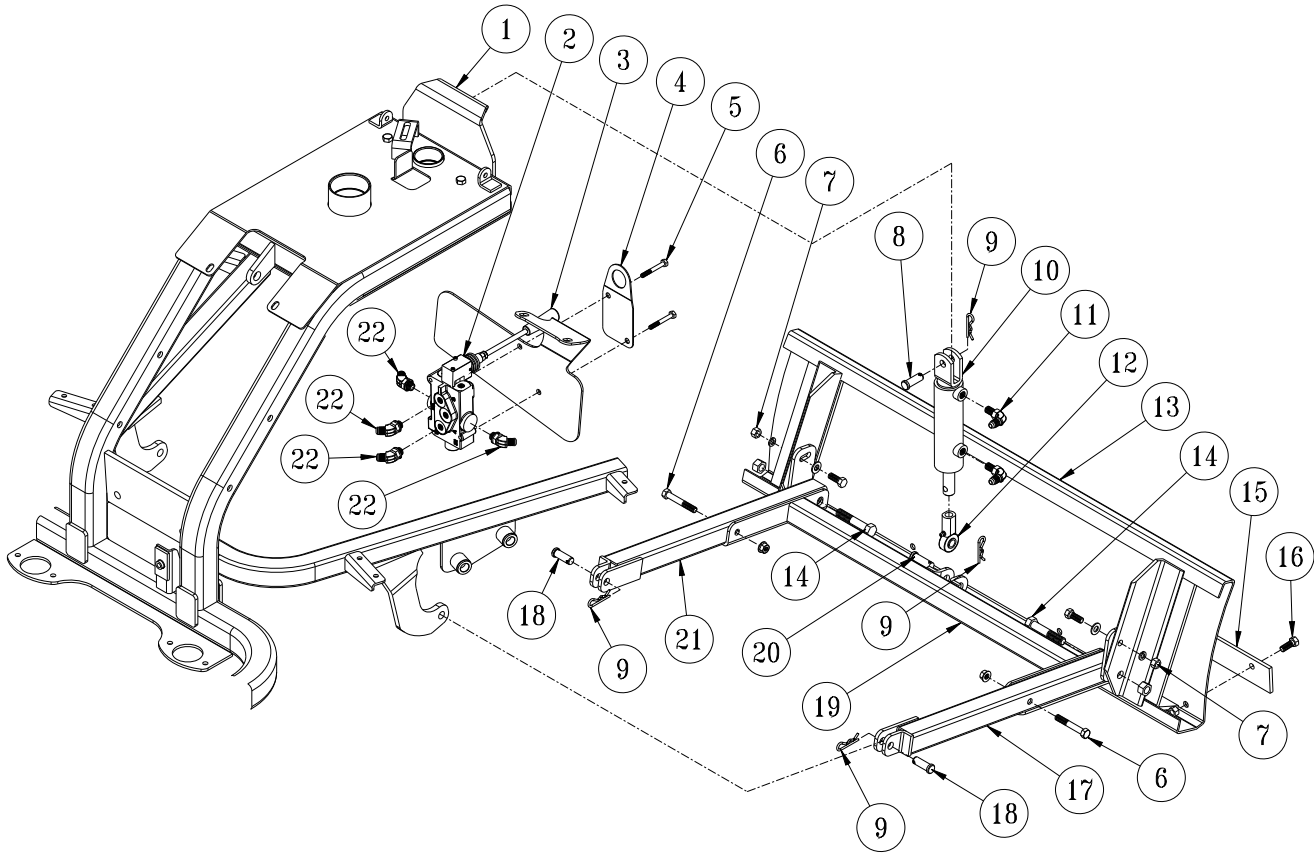

HYDRAULIC VALVE PLUMBING DRAWING

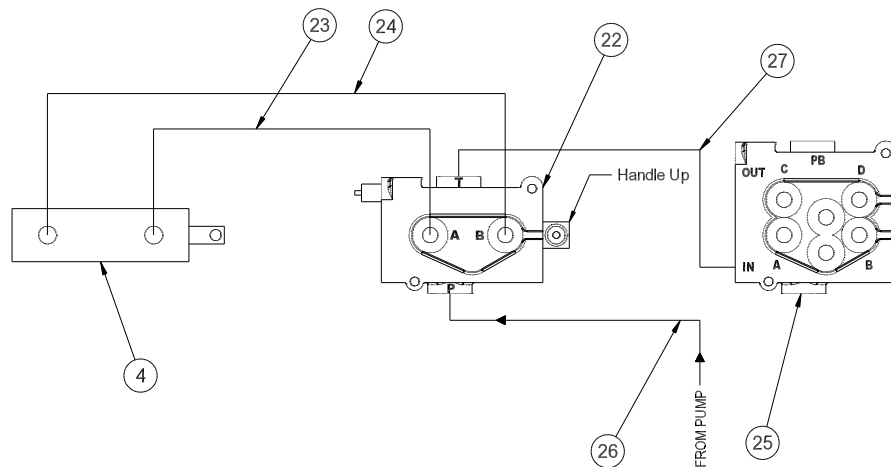

45-005 HYDRAULIC SAND PLOW PARTS LIST

REF#	PART#	DESCRIPTION	QUANTITY
1	45-126	Ram Mount	1
2	13-765	Single Bank Hydraulic Valve	1
3	78-417	Straight Handle	1
4	45-127	Valve Mount	1
5	HB-14-20-200	Bolt, $\frac{1}{4}$ - 20 x 2	2
	HNFL-14-20	Flange Whiz-Lock Nut, $\frac{1}{4}$ - 20	2
6	HB-38-16-250	Bolt, $\frac{3}{8}$ - 16 x $2\frac{1}{2}$	2
	HNTL-38-16	Lock Nut, $\frac{3}{8}$ - 16	2
7	HB-38-16-125	Bolt, $\frac{3}{8}$ - 16 x $1\frac{1}{4}$	2
	HW-38	Washer, $\frac{3}{8}$	2
	HWL-38	Lockwasher, $\frac{3}{8}$	2
	HN-38-16	Nut, $\frac{3}{8}$ - 16	2
8	HCP-58-150	Clevis Pin, $\frac{5}{8}$ x $1\frac{1}{2}$	1
9	HHP-18	Bridge Pin, $\frac{1}{8}$	4
10	13-406	Hydraulic Cylinder	1
11	18-168	90° Elbow	2
12	18-154	Rod End	1
	HNJ-58-18	Jam Nut, $\frac{5}{8}$ - 18	1
13	45-092	Aluminum Sand Plow Blade	1
	45-321	Steel Sand Plow Blade	1
14	HB-12-13-300	Bolt, $\frac{1}{2}$ - 13 x 3	2
	HNTL-12-13	Lock Nut, $\frac{1}{2}$ - 13	2
15	13-167	Wear Blade	1
16	HB-38-16-100	Bolt, $\frac{3}{8}$ - 16 x 1	4
	HNFL-38-16	Flange Whiz Lock Nut, $\frac{3}{8}$ - 16	4
17	45-100	Right Pusher Bar	1
18	HCP-12-150	Clevis Pin, $\frac{1}{2}$ x $1\frac{1}{2}$	2
19	45-125	Plow Crossbar	1
20	HCP-58-175	Clevis Pin, $\frac{5}{8}$ x $1\frac{3}{4}$	1
21	45-101	Left Pusher Bar	1
22	18-341	45° Elbow	4
23	45-130	Hose, 51½"	1
24	45-129	Hose, 43"	1
25		2-Bank Valve (on machine)	
26	45-068	Hose (on machine to pump)	
27	45-128	Hose, 26"	1

ENGINE MUST BE COOL BEFORE DISCONNECTING THE HOSES.

1. Assemble pusher bars (Ref# 17 and 21) to plow blade (Ref# 13) using one $\frac{3}{8}$ -16 x $1\frac{1}{4}$ bolt (Ref# 7) and one $\frac{3}{8}$ -16 x 3 bolt (Ref#14) per pusher bar. There are 2 holes to bolt (Ref# 7) hardware in. Using hole **closest to the blade will result in a shallow cut**, whereas using the hole **furthest from the blade will result in a deeper cut**. The slot on the pusher bar is for a more fine tuned adjustment.
2. Assemble the plow cross tube (Ref# 19) to the front pusher bars (Ref# 17 and 21) using $\frac{3}{8}$ - 16 x $2\frac{1}{2}$ bolts and lock nuts (Ref# 6). Cylinder tabs pointed front.
3. Assemble the ram mount (Ref# 1) to the main frame using the two studs that are welded to the frame and below the front of the console. Install rod end (Ref# 12) onto cylinder with $\frac{5}{8}$ jam nut.
4. Using a $\frac{5}{8}$ x $1\frac{3}{4}$ clevis pin (Ref# 20) and $\frac{1}{8}$ " bridge pin (Ref# 9) mount the hydraulic cylinder (Ref# 10) to the plow crossbar (Ref# 19). Connect the other end of the hydraulic cylinder to the ram mount (Ref# 1) using $\frac{5}{8}$ x $1\frac{1}{2}$ Clevis Pin (Ref# 8) and $\frac{1}{8}$ " bridge pin (Ref# 9).
5. Slide the plow/pusher bar assembly under machine and connect to machine. Secure using $\frac{1}{2}$ x $1\frac{1}{2}$ clevis pins (Ref# 18) and $\frac{1}{8}$ " bridge pins (Ref# 9).

45-005 HYDRAULIC SAND PLOW DRAWING

Front Attachment

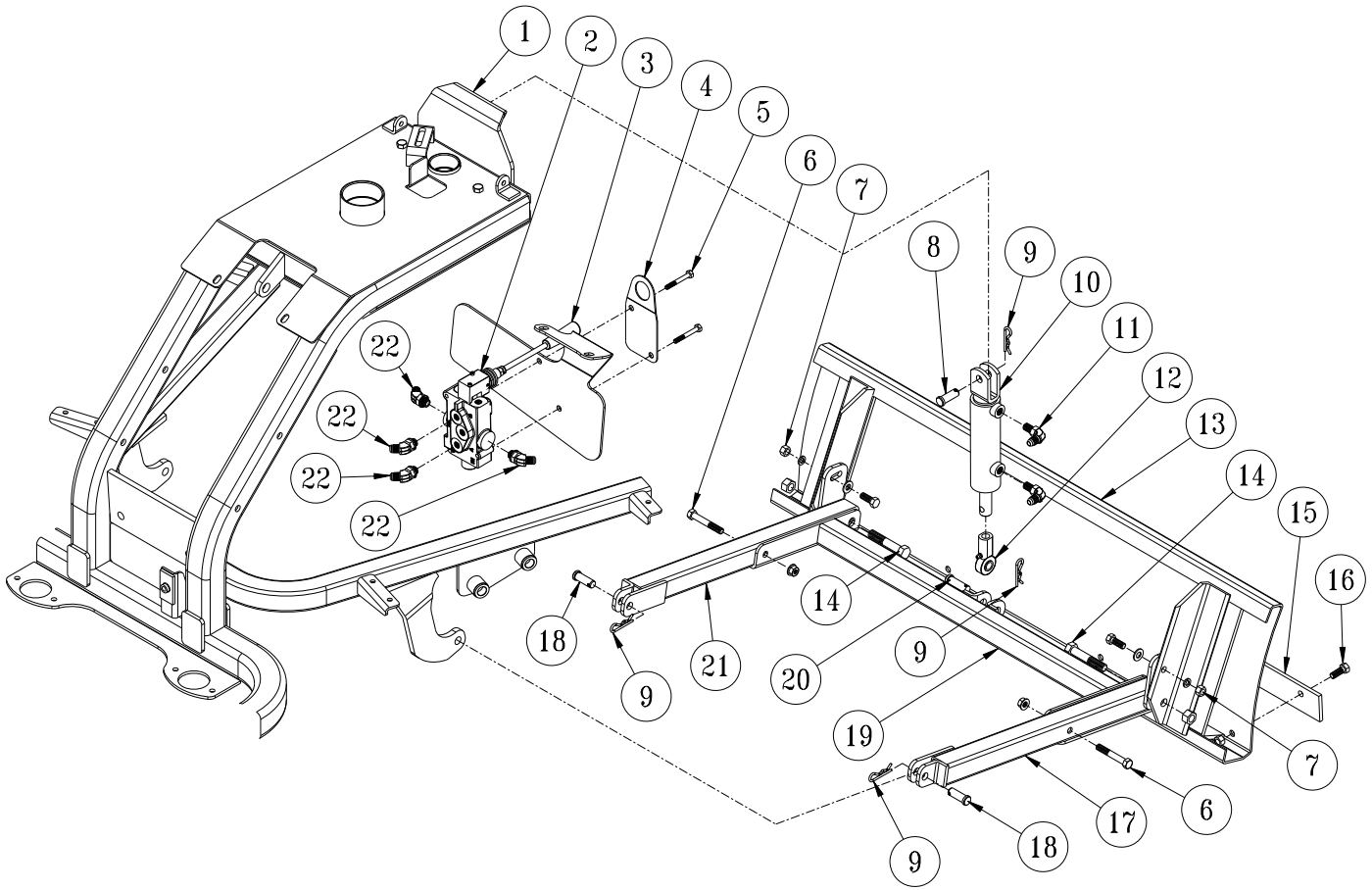

HYDRAULIC VALVE PLUMBING DRAWING

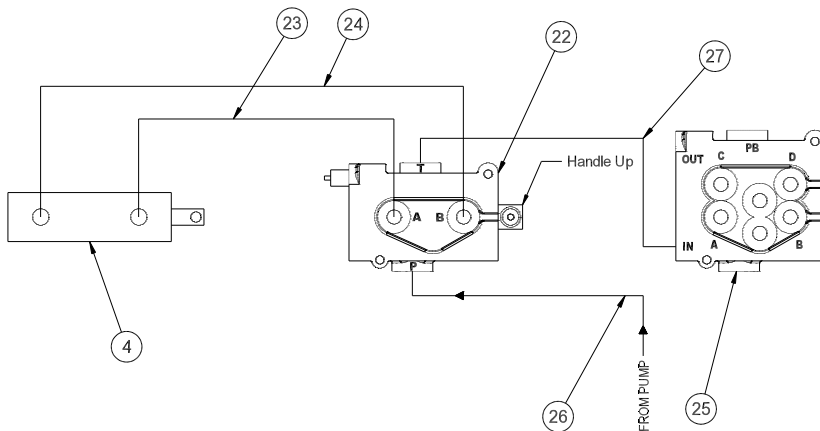

45-005 HYDRAULIC SAND PLOW INSTRUCTIONS

6. Thread four, 45° elbow fittings (Ref# 22) into the single bank valve (Ref# 2), one each in the **A** port, **B** port, **IN** port and **OUT** port. Reference *Single Bank Hydraulic Valve Drawing* for a detailed view of the valve.
7. Thread two, 3/8 straight thread elbow fittings (Ref# 11) into the ports on the hydraulic cylinder (Ref# 10). Make sure the fittings on the hydraulic cylinder are pointing towards the machine.
8. Next connect the 43" hose (Ref# 24) to the fitting in the **B** port and connect the 51.5" hose (Ref# 23) to the fitting in the **A** port.
9. Fiberglass Fender: Using the valve mount as a template, Measure in approximately 4.25 inches from edge of right fender and mark. Line valve mount up with contour of the fender and the right side of the line you just marked. Trace holes onto fiberglass. CARB Canister is underneath so use caution when drilling holes out.
10. Fiberglass Fender: Mount the single bank hydraulic Valve (Ref# 2) to the valve mount (Ref# 4) as illustrated, using the two 1/4 - 20 x 2 bolts (Ref# 5). Secure with the two 1/4 - 20 flange whiz-lock nuts. Connect the straight handle (Ref# 3) to the valve. Reference *Single Bank Hydraulic Valve Drawing* for a detailed view of the valve.
11. Plastic Fender: The Valve assembly mounts on the right front fender. The Valve goes underneath the fender with the handle pointing outward. The Valve Mount Plate (Ref 4) mounts on the outside of the fender. The Valve Brace mounts inside the fender.
12. Plastic Fender: Remove the 4 bolts holding the fender to the mainframe. Working on the inside of the fender, place the Valve Brace, with the slotted holes lined up with the fender holes, and the face with the offset holes against the front of the fender, as shown in the photo. Mark the location of the two offset holes. Drill a 3/8" hole at each mark. Use a piece of scrap wood to drill into to prevent tearing the plastic fender.
13. Position the Valve Mount (Ref 4) so the holes line up with the holes that you drilled. Mark location of the large hole then drill a 1 1/4" hole at that mark. Use a piece of scrap wood to drill into to prevent tearing the plastic fender.
14. Route the 43" hose (Ref# 24) from the **B** port on the single bank hydraulic valve to the top port on the hydraulic cylinder. Route the 51.5" hose (Ref# 23) from the **A** port on the single bank hydraulic valve to the bottom port on the cylinder.
15. Disconnect the negative (-) ground battery cable from the battery. Place a drain pan under the valve on the machine. **ENGINE MUST BE COOL BEFORE DISCONNECTING THE HOSES.**
16. Disconnect hose (Ref# 26) from the **IN** port on the two-bank hydraulic valve (Ref#25). Connect this hose (Ref# 26) to the "**P**" port of the single bank valve (Ref# 2). Connect the 26" hose (Ref# 27) from the "**T**" port on the single bank valve (Ref# 2) to the **IN** port of the two-Bank valve (Ref# 25). Fasten to the frame using the 14 1/2" nylon ties.
17. Reconnect the negative (-) ground battery cable to battery.
18. Make sure that everything is clear of the machine. Start the machine, work the valve so that the plow will both raise and lower. Also, do this with both the attachment lift and the rake lift. Work the lift a number of times until all air works out of the plow circuit and the cylinder works smoothly. At this time look for hydraulic leaks. If there are leaks, turn engine off and repair, start up and check again.
19. Check the hydraulic oil level. The level should be 2" to 2 1/2" below the top of the tank. If more is needed, use SAE 10W-40 API service SG motor oil.



45-009 ALUMINUM SAND PLOW DRAWING

Front Attachment

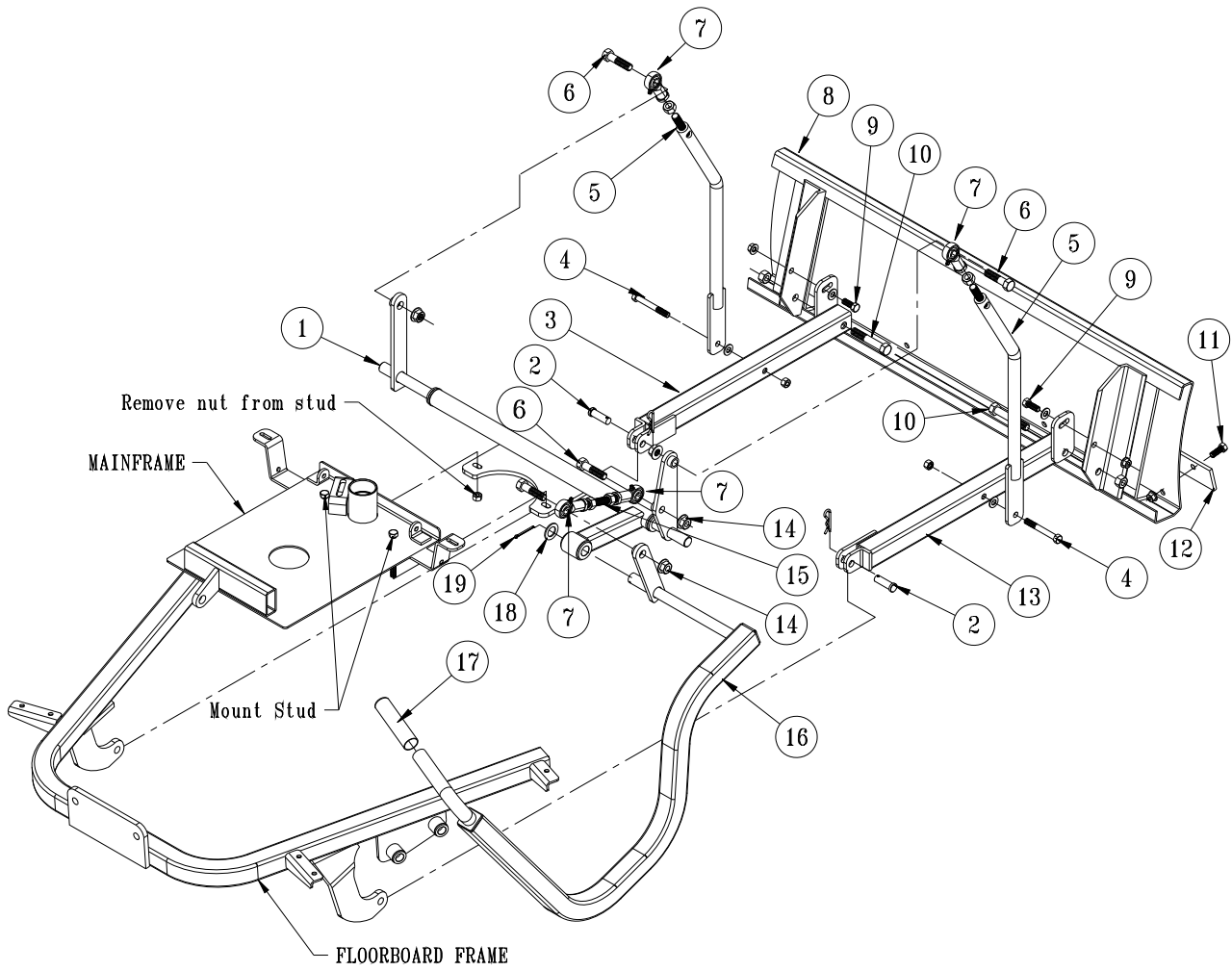

45-009 ALUMINUM SAND PLOW PARTS LIST

REF#	PART#	DESCRIPTION	QUANTITY
1	45-419	Lift Assembly	1
	18-221	Bushing	2
2	HCP-12-150	Clevis Pin, 1/2 x 1 1/2	2
	HHP-18	Bridge Pin, 1/8	2
3	45-101	Left Pusher Bar	1
4	HB-38-16-250	Hex Bolt, 3/8 - 16 x 2 1/2	2
	HW-38	Flat Washer, 3/8	4
	HNTL-38-16	Nylon Lock Nut, 3/8 - 16	2
5	27-073	Lift Rod	2
6	HB-12-13-200	Hex Bolt, 1/2 - 13 x 2	4
7	80-006	Rod End	4
	HNJ-12-20	Jam Nut, 1/2 - 20	4
8	45-092	40" Aluminum Sand Plow Blade	1
	45-321	40" Steel Blade	1
9	HB-38-16-125	Hex Bolt, 3/8 - 16 x 1 1/4	2
	HNFL-38-16	Flange Whiz-loc Nut, 3/8 - 16	2
10	HB-12-13-300	Hex Bolt, 1/2 - 13 x 3	2
	HNTL-12-13	Nylon Lock Nut, 1/2 - 13	2
11	HB-38-16-100	Hex Bolt, 3/8 - 16 x 1	4
	HNFL-38-16	Flange Whiz-Loc Nut, 3/8 - 16	4
12	13-167	Wear Blade	1
13	45-100	Right Pusher Bar	1
14	HNFL-12-13	Flange Whiz-loc Nut, 1/2 - 13	4
15	42-348	Rod	1
16	45-418	Plow Handle	1
17	15-019	Grip	1
18	HMB-34-14	Machine Bushing, 3/4 - 14GA	1
19	HP-18-150	Cotter Pin, 1/8 x 1 1/2	1

SAND PLOW INSTALLATION

- Assemble (Ref# 3 and 13) pusher bars to (Ref# 8) plow using (Ref# 9 and 10) hardware. There are 2 holes to bolt (Ref# 9) hardware in. Using hole closest to the blade will result in a shallow cut, whereas using the hole furthest from the blade will result in a deeper cut. The slot on the pusher bar is for a more fine tuned adjustment.
- Attach the (Ref# 1) lift assembly to the main frame. There are two studs on the front frame below the front nose console. Remove the nuts on those studs (the studs also hold the floorboard braces). Place the lift assembly on studs next to the floorboard brackets and replace nuts. Tighten nuts down.
- Attach the (Ref# 6) lift handle to the lift assembly using (Ref# 18 & 19) machine bushing and cotter pin. Using (Ref# 15 & 7) rod and yoke attach the handle to the lift assembly.
- Put (Ref# 7) rod ends onto (Ref# 5) lift rods with jam nut first. Adjust to equal lengths. Bolt lift rods to lift arms with ball joints to the outside. Bolt from outside with the 1/2 - 13 nut on the inside. Use (Ref# 6) Hardware.
- Slide plow under machine and connect to machine. Use (Ref# 2) clevis pin and bridge pin.
- Lift up the plow using the bottom hole in the lift rod as a starting point. Secure to the pusher bars. Use (Ref# 4) hardware. For maximum blade clearance use the second hole from the front of the pusher bar. The three holes in the lift rods are for adjusting the hand lever. The top hole moves the lever forward. Each hole down moves the lever to the rear of the machine.
- For fine tuning of blade height off ground twist (Ref# 7) rod end on (Ref# 15) rod. Twisting the rod end out will increase down pressure. Twisting the rod end onto the rod will decrease down pressure.

45-019 ALUMINUM 60" SAND PLOW DRAWING

Front Attachment

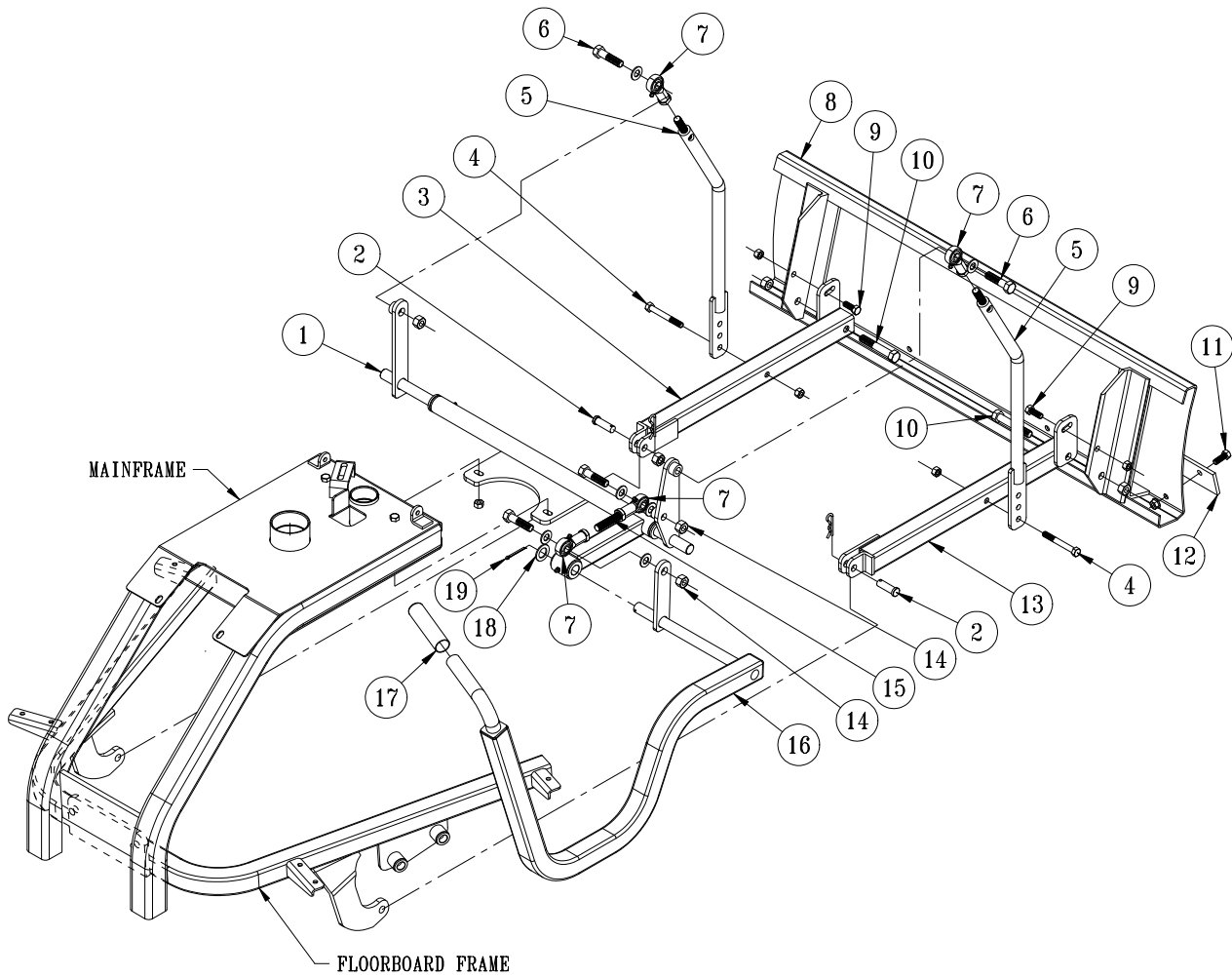

45-019 ALUMINUM 60" SAND PLOW PARTS LIST

REF#	PART#	DESCRIPTION	QUANTITY
1	45-106	Lift Assembly	1
	18-221	Flange Bushing	2
2	HCP-12-150	Clevis Pin, 1/2 x 1 1/2	2
	HHP-18	Bridge Pin, 1/8	2
3	45-101	Left Pusher Bar	1
4	HB-38-16-250	Hex Bolt, 3/8 - 16 x 2 1/2	2
	HW-38	Flat Washer, 3/8	4
	HNTL-38-16	Nylon Lock Nut, 3/8 - 16	2
5	27-073	Lift Rod	2
6	HB-12-13-200	Hex Bolt, 1/2 - 13 x 2	2
	HMB-12-14	Machine Bushing, 1/2 x 14GA	8
	HNTL-12-13	Nylon Lock Nut, 1/2 - 13	2
7	80-006	Rod End	4
	HNJ-12-20	Jam Nut, 1/2 - 20	4
8	45-159	Aluminum Sand Plow Blade	1
9	HB-38-16-125	Hex Bolt, 3/8 - 16 x 1 1/4	2
	HW-38	Flat Washer, 3/8	2
	HWL-38	Lock Washer, 3/8	2
	HN-38-16	Hex Nut, 3/8 - 16	2
10	HB-12-13-300	Hex Bolt, 1/2 - 13 x 3	2
	HNTL-12-13	Nylon Lock Nut, 1/2 - 13	2
11	HB-38-16-100	Hex Bolt, 3/8 - 16 x 1	4
	HNFL-38-16	Flange Whiz-Loc Nut, 3/8 - 16	4
12	35-012	Wear Blade	1
13	45-100	Right Pusher Bar	1
14	HB-12-13-200	Hex Bolt, 1/2 - 13 x 2	2
	HMB-12-14	Machine Bushing, 1/2 x 14GA	2
	HNTL-12-13	Nylon Lock Nut, 1/2 - 13	2
15	27-073	Plow Link. 3"	1
16	45-097	Plow Handle	1
17	15-019	Grip	1
18	HMB-34-14	Machine Bushing, 3/4 - 14GA	1
19	HP-18-150	Cotter Pin, 1/8 x 1 1/2	1

SAND PLOW INSTALLATION

- Assemble (Ref# 3 and 13) Pusher Bars to (Ref# 8) Plow using (Ref# 9 and 10) hardware. There are 2 holes to Hex Bolt (Ref# 9) hardware in. Using hole closest to the blade will result in a shallow cut, whereas using the hole furthest from the blade will result in a deeper cut. The slot on the pusher bar is for a more fine tuned adjustment.
- Assemble the (Ref# 1) Lift Assembly to the Main Frame using the two studs that are under the frame and below the front of the console.
- Attach the (Ref# 6) Lift Handle to the lift assembly using (Ref# 18 & 19) Cotter Pin and Machine Bushing. Using (Ref# 15 & 7) Rod and Yoke attach the handle to the lift assembly.
- Put (Ref# 7) Rod Ends onto (Ref# 10) Lift Rods with Jam Nut first. Adjust to equal lengths. Hex Bolt Lift Rods to Lift Arms with Ball Joints to the outside. Hex Bolt from outside with the 1/2" Machine Bushing between Rod End and Lift Arm and the 1/2 - 13 nut on the inside. Use (Ref# 6) Hardware.
- Slide Plow under machine and connect to machine. Use (Ref# 2) Clevis Pin and Bridge Pin.
- Lift up the plow using the bottom hole in the Lift Rod as a starting point. Secure to the Pusher Bars. Use (Ref# 4) hardware. For maximum blade clearance use the second hole from the front of the pusher bar. The three holes in the lift rods are for adjusting the hand lever. The top hole moves the lever forward. Each hole down moves the lever to the rear of the machine.
- For fine tuning of blade height off ground twist (Ref# 7) rod end on (Ref# 15) rod. Twisting the rod end out will increase down pressure. Twisting the rod end onto the rod will decrease down pressure.

45-179 40" ANGLE PLOW

Front Attachment

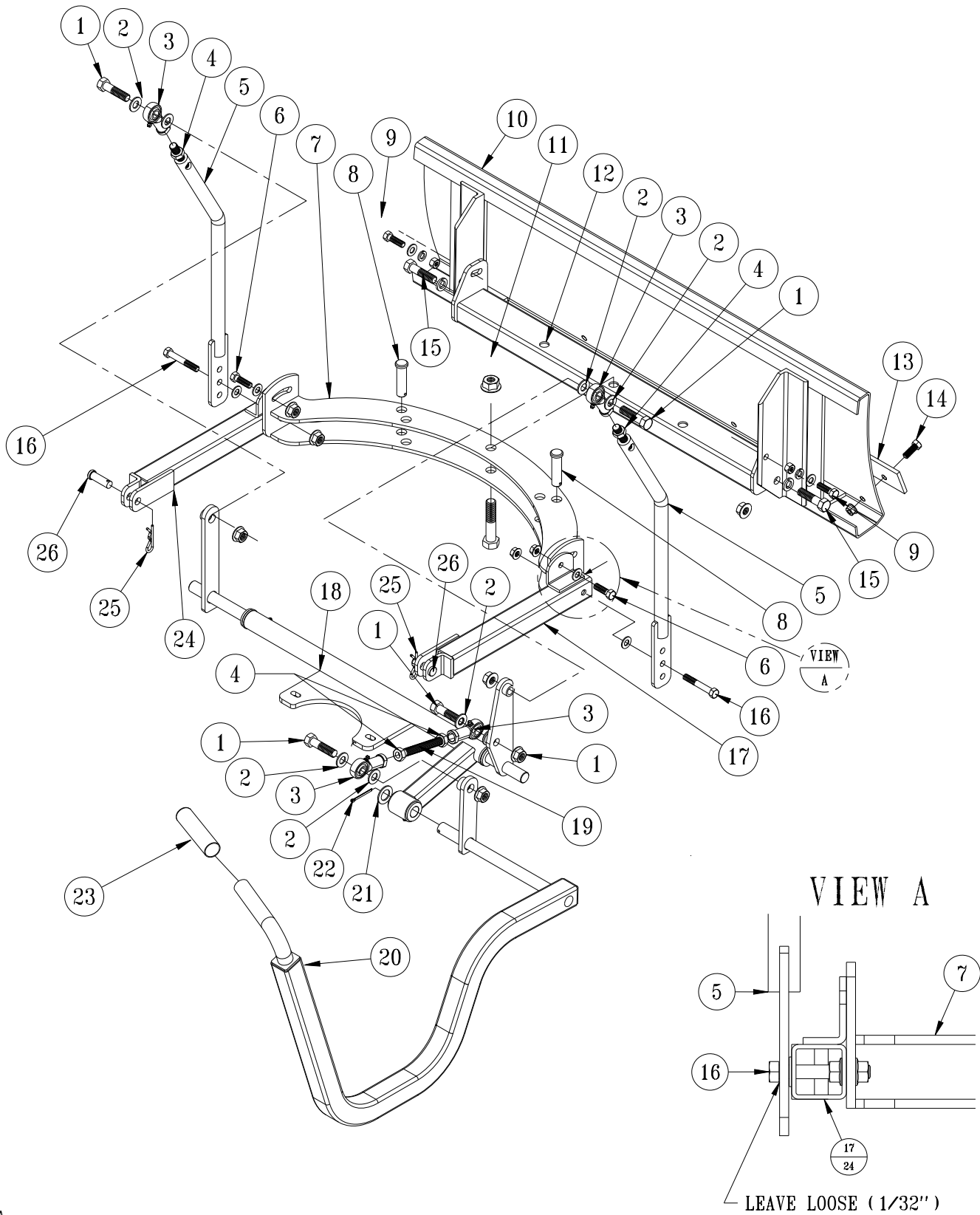

45-179 40" ANGLE PLOW PARTS LIST

REF#	PART#	DESCRIPTION	QUANTITY
1	HB-12-13-200	Hex Bolt, 1/2 - 13 x 2	4
	HNTL-12-13	Nylon Lock Nut, 1/2 - 13	4
2	HMB-12-14	Machine Bushing, 1/2 x 14GA	8
3	80-006	Rod End	4
4	HNJ-12-20	Jam Nut, 1/2 - 20	4
5	27-073	Lift Rod	2
6	HB-38-16-125	Hex Bolt, 5/8 - 16 x 1 1/4	2
	HNFL-38-16	Flange Whiz-Loc Nut, 5/8 - 16	2
7	45-181	Plow Mount	1
8	HCP-58-250	Clevis Pin, 5/8 x 2 1/2	2
	HHP-18	Bridge Pin, 1/8	2
9	HB-38-16-125	Hex Bolt, 3/8 - 16 x 1 1/4	2
	HW-38	Flat Washer, 3/8	2
	HWL-38	Lock Washer, 3/8	2
	HN-38-16	Hex Nut, 3/8 - 16	2
10	27-017	Aluminum Sand Plow Blade	1
11	HB-58-11-300	Hex Bolt, 5/8 - 11 x 3	1
	HNTL-58-11	Nylon Lock Nut, 5/8 - 11	1
12	42-495	Pivot Frame	1
13	13-167	Wear Blade	1
14	HB-38-16-100	Hex Bolt, 3/8 - 16 x 1	4
	HNFL-38-16	Flange Whiz-Loc Nut, 3/8 - 16	4
15	HB-12-13-200	Hex Bolt, 1/2 - 13 x 2	2
	HWL-12	Lock Washer, 1/2	2
16	HB-38-16-250	Hex Bolt, 3/8 - 16 x 2 1/2	2
	HW-38	Flat Washer, 3/8	2
	HNTL-38-16	Nylon Lock Nut, 3/8 - 16	4
17	45-231	Right Pusher Bar	1
18	45-106	Lift Assembly	1
	18-221	Flange Bushing	2
19	27-073-02	Plow Link, 3"	1
20	45-097	Lift Handle	1
21	HMB-34-14	Machine Bushing, 3/4 - 14GA	1
22	HP-18-150	Cotter Pin, 1/8 x 1 1/2	1
23	15-019	Grip	1
24	45-232	Left Pusher Bar	1
25	HHP-18	Bridge Pin, 1/8	2
26	HCP-12-150	Clevis Pin, 1/2 x 1 1/2	2

45-180 60" ANGLE PLOW

Front Attachment

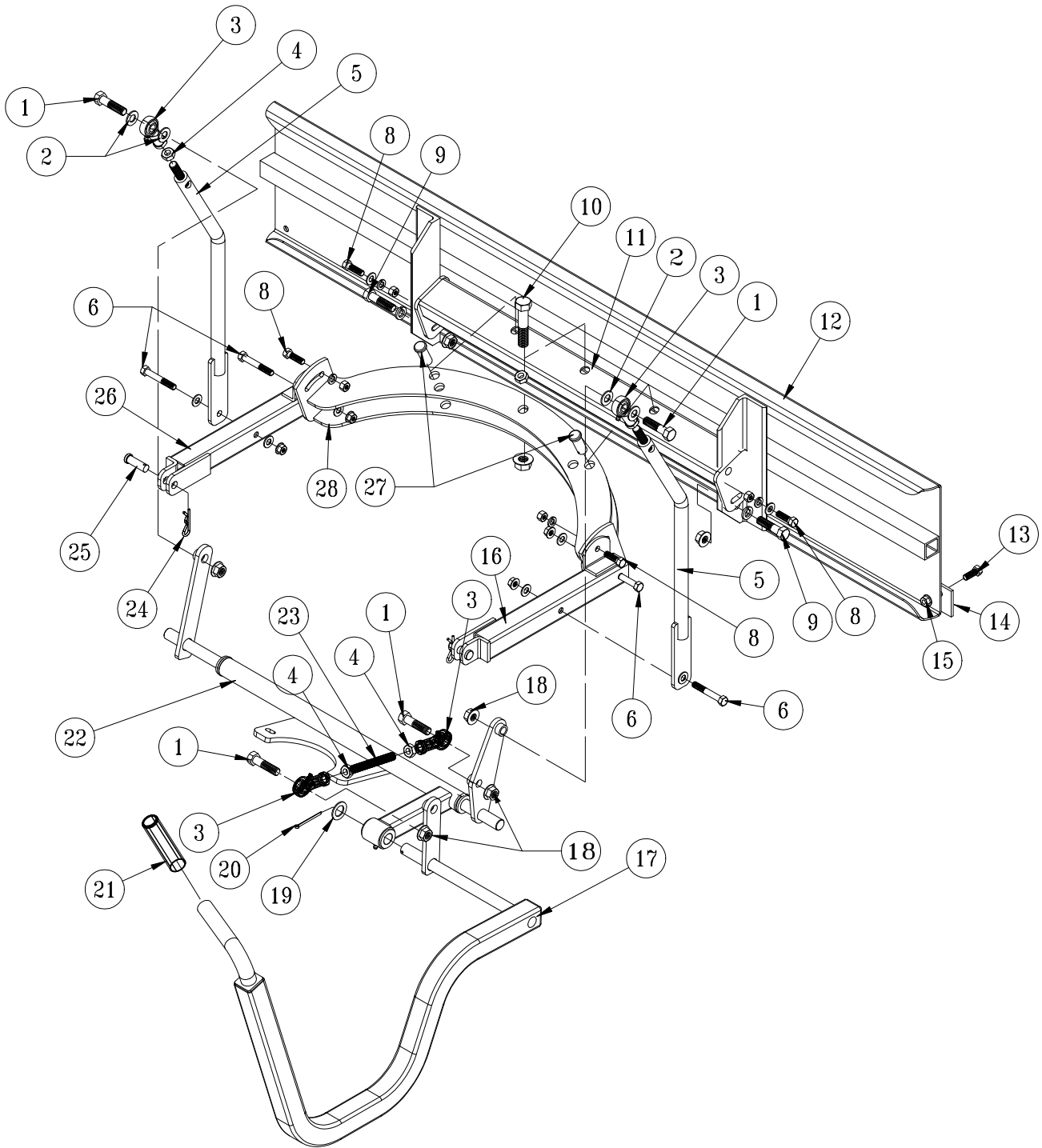

45-180 60" ANGLE PLOW PARTS LIST

REF#	PART#	DESCRIPTION	QUANTITY
1	HB-12-13-200	Hex Bolt, 1/2 - 13 x 2	4
2	HMB-12-14	Machine Bushing, 1/2 x 14GA	8
3	80-006	Rod End	4
4	HNJ-12-20	Jam Nut, 1/2 - 20	4
5	27-073	Lift Rod	2
6	HB-38-16-250	Hex Bolt, 3/8 - 16 x 2 1/2	2
	HW-38	Flat Washer, 3/8	4
	HNTL-38-16	Nylon Lock Nut, 3/8 - 16	2
7	HB-38-16-250	Hex Bolt, 3/8 - 16 x 2 1/2	2
	HNTL-38-16	Nylon Lock Nut, 3/8 - 16	2
8	HB-38-16-125	Hex Bolt, 3/8 - 16 x 1 1/4	4
	HW-38	Flat Washer, 3/8	4
	HWL-38	Lock Washer, 3/8	4
	HN-38-16	Hex Nut, 3/8 - 16	4
9	HB-12-13-200	Hex Bolt, 1/2 - 13 x 2	2
	HNTL-12-13	Nylon Lock Nut, 1/2 - 13	2
10	HB-58-11-300	Hex Bolt, 5/8 - 11 x 3	1
	HNTL-58-11	Nylon Lock Nut, 5/8 - 11	1
11	42-495	Pivot Frame	1
12	45-159	Aluminum 60" Sand Plow Blade	1
13	HB-38-16-100	Hex Bolt, 3/8 - 16 x 1	4
14	35-012	Wear Blade	1
15	HNFL-38-16	Flange Whiz-Loc Nut, 3/8 - 16	4
16	45-182	Right Pusher Bar	1
17	45-097	Lift Handle	1
	18-221	Flange Bushing	2
18	HNTL-12-13	Nylon Lock Nut, 1/2 - 13	4
19	HMB-34-14	Machine Bushing, 3/4 - 14GA	1
20	HP-18-150	Cotter Pin, 1/8 x 1 1/2	1
21	15-019	Grip	1
22	45-106	Lift Assembly	1
	18-221	Flange Bushing	2
23	27-073-02	Plow link. 3"	1
24	HHP-18	Bridge Pin, 1/8	2
25	HCP-12-150	Clevis Pin, 1/2 x 1 1/2	2
26	45-183	Left Pusher Bar	1
27	HCP-58-250	Clevis Pin, 5/8 x 2 1/2	2
	HHP-18	Bridge Pin, 1/8	2
28	45-181	Plow Mount	1

45-014 WEED CULTIVATOR

Center Attachment

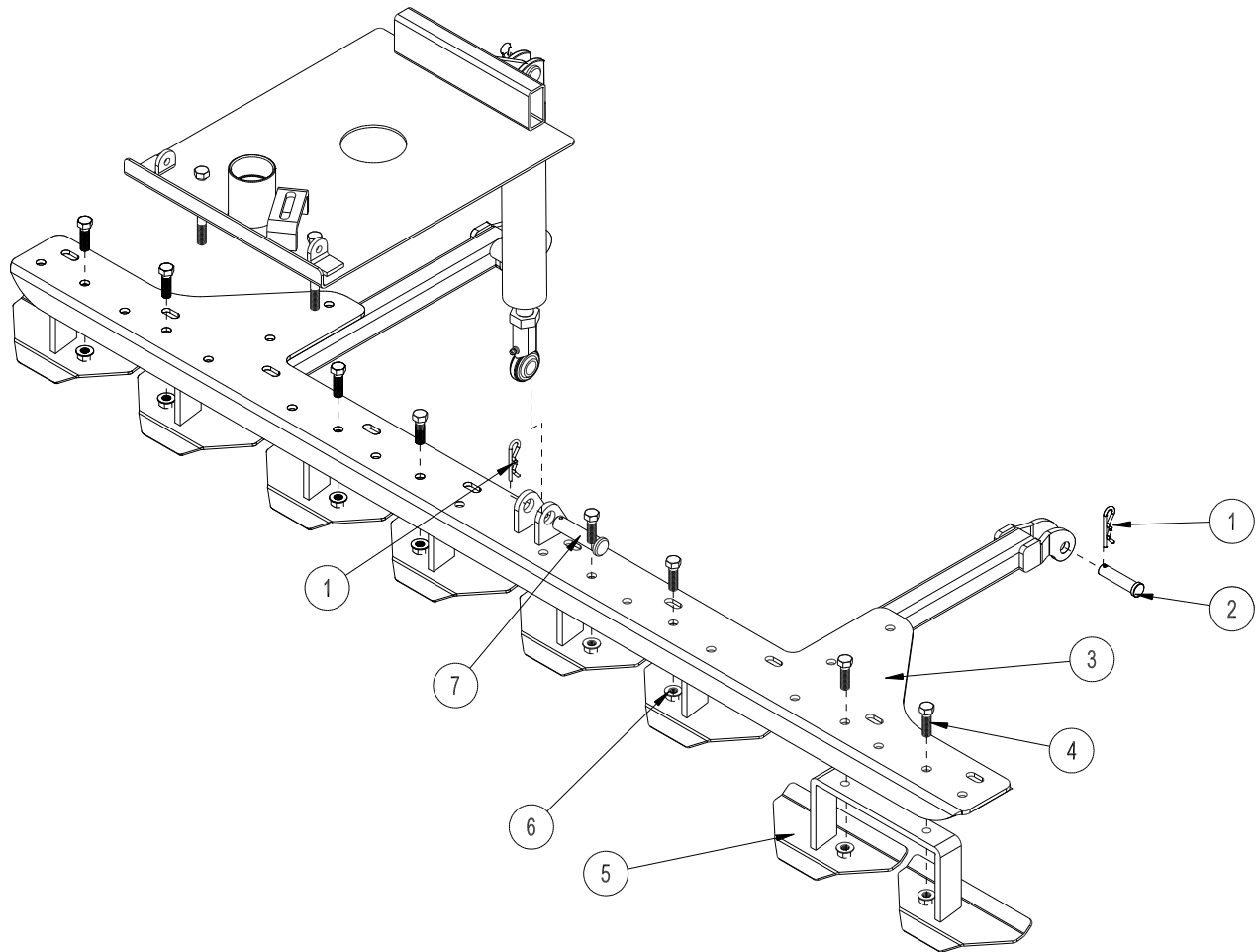

45-014 WEED CULTIVATOR

REF#	PART #	DESCRIPTION	QUANTITY
1	HHP-18	Bridge Pin, $\frac{1}{8}$	3
2	HCP-12-200	Clevis Pin, $\frac{1}{2} \times 2$	2
3	45-185	Center Bar Lift	1
4	HB-38-16-125	Hex Bolt, $\frac{3}{8} - 16 \times 1\frac{1}{4}$	8
5	13-096	Blade Assembly	4
6	HNFL-38-16	Flange Nut, $\frac{3}{8} - 16$	8
7	HCP-58-250	Clevis Pin, $\frac{5}{8} \times 2\frac{1}{2}$	1

INSTALLATION INSTRUCTIONS

1. Blade assemblies (Ref 5) should be Hex Bolted to the center lift bar (Ref 3). Use the $\frac{3}{8}$ - 16 x $1\frac{1}{4}$ Hex Bolt (Ref 4) and Flange Whiz-Loc Nut (Ref 6).
2. Attach the center lift bar to main frame using (Ref 1 and 2) clevis pin and bridge pin.
3. Lift center lift bar up or extend cylinder so rod end lines up with the holes on the center of the attachment lift. Use clevis pin and bridge pin (Ref 7 and 1) to fasten cylinder to sand cultivator.
4. Turn machine on and test for proper operation.

45-006 SAND CULTIVATOR DRAWING

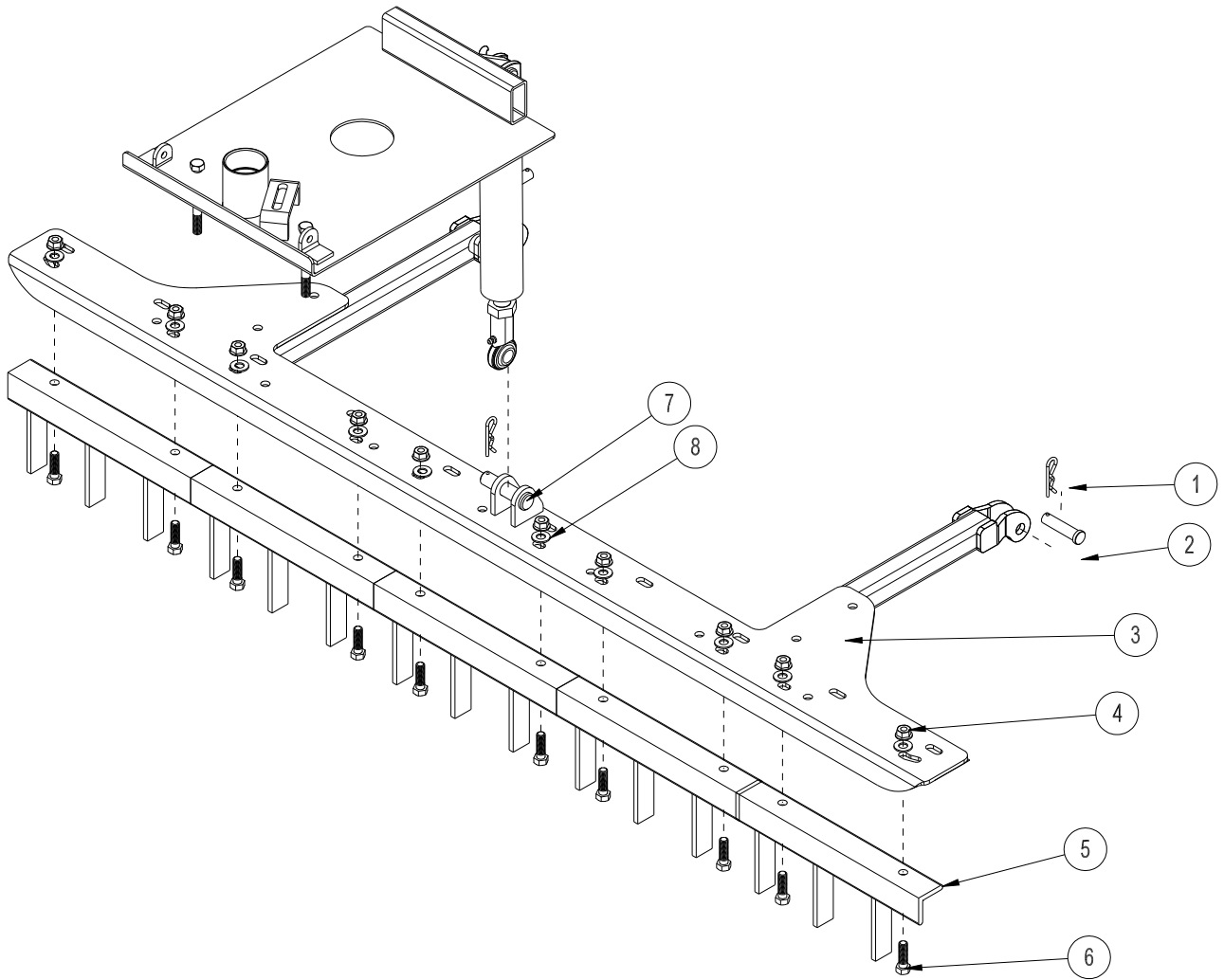

Center Attachment

45-006 SAND CULTIVATOR PARTS LIST

REF#	PART#	DESCRIPTION	QTY
1	HHP-18	Bridge Pin, $\frac{1}{8}$	3
2	HCP-12-200	Clevis Pin, $\frac{1}{2} \times 2$	2
3	45-184	Center Lift Bar	1
4	HNTL-38-16	Nylon Lock Nut, $\frac{3}{8}$ - 16	10
5	42-038	Tine Segment	5
6	HB-38-16-100	Hex Bolt, $\frac{3}{8}$ - 16 x 1	10
7	HCP-58-250	Clevis Pin, $\frac{5}{8} \times 2\frac{1}{2}$	1

INSTALLATION INSTRUCTIONS

1. Tine segments (Ref 5) should be Hex Bolted to the center lift bar (Ref 3). Use the $\frac{3}{8}$ - 16 x 1 Hex Bolt (Ref 6) and Nylon Lock Nut (Ref 4).
2. Attach the center lift bar to main frame using (Ref 1 and 2) clevis pin and bridge pin.
3. Lift center lift bar up or extend cylinder so rod end lines up with the holes on the center of the attachment lift. Use clevis pin and bridge pin (Ref 7 and 1) to fasten cylinder to sand cultivator.
4. Turn machine on and test for proper operation.

45-008 SAND CULTIVATOR WITH SPRING TINES DRAWING

Center Attachment

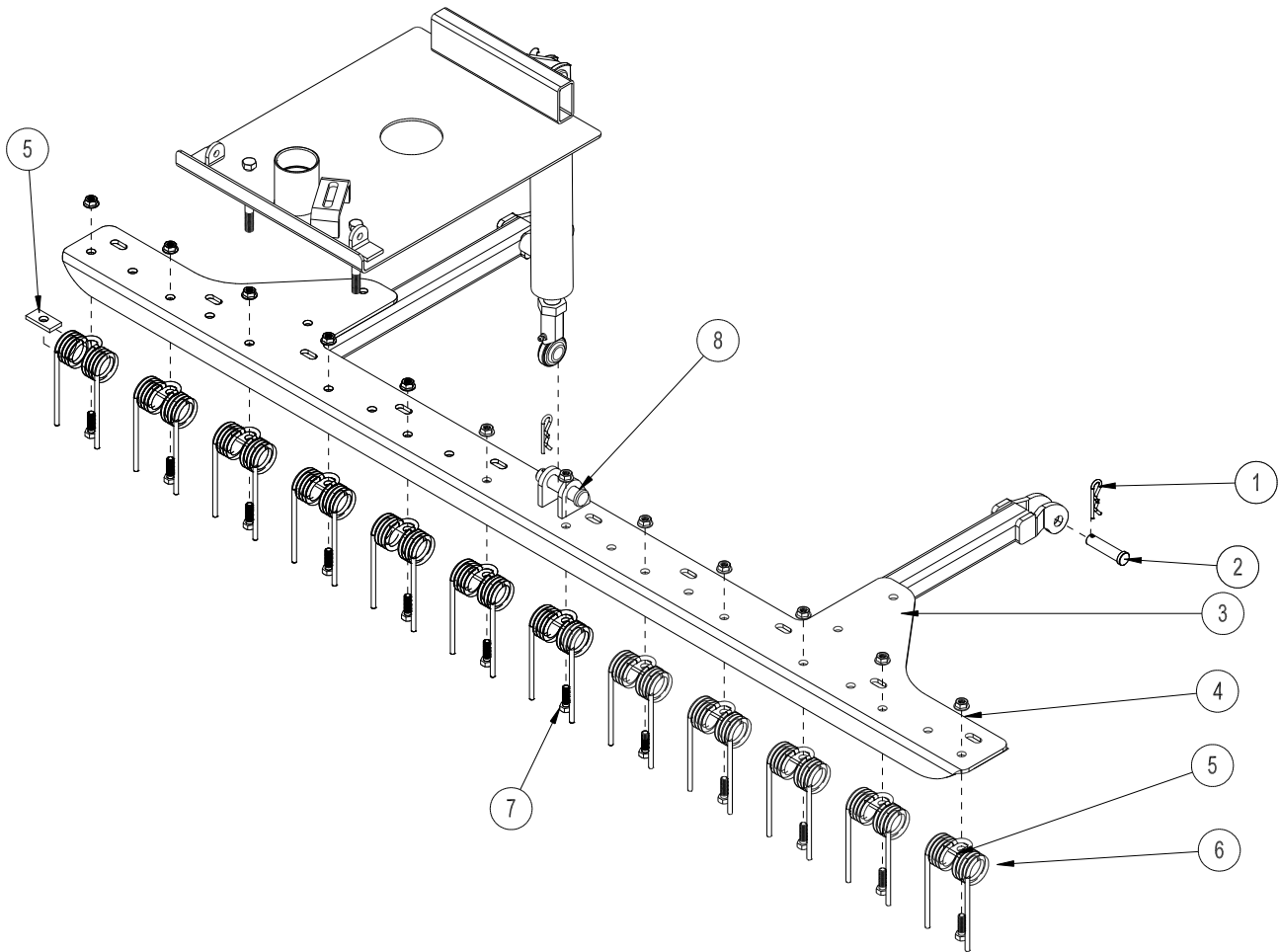

45-008 SAND CULTIVATOR WITH SPRING TINES PARTS LIST

REF#	PART#	DESCRIPTION	QUANTITY
1	HHP-18	Bridge Pin, $\frac{1}{8}$	3
2	HCP-12-200	Clevis Pin, $\frac{1}{2} \times 2$	2
3	45-185	Center Lift Bar	1
4	HNFL-516-18	Flange Whiz-loc Nut, $\frac{5}{16} - 18$	12
5	42-177	Spring Holder	12
6	42-122	Rake Spring	12
7	HB-516-18-150	Hex Bolt, $\frac{5}{16} - 18 \times 1\frac{1}{2}$	12
8	HCP-58-250	Clevis Pin, $\frac{5}{8} \times 2\frac{1}{2}$	1

INSTALLATION INSTRUCTIONS

1. Springs (Ref 6) should be Hex Bolted to the center lift bar (Ref 3) with the spring holder (Ref 5) between center lift bar and the spring. Hex Bolt in place with $\frac{5}{16} - 18$ Hex Bolt (Ref 7) and whiz-loc Nut (Ref 4).
2. Attach the center lift bar to main frame using (Ref 1 and 2) clevis pin and bridge pin.
3. Lift center lift bar up or extend cylinder so rod end lines up with the holes on the center of the attachment lift. Use clevis pin and bridge pin (Ref 8 and 1) to fasten cylinder to sand cultivator.
4. Turn machine on and test for proper operation.

45-012 CONSTRUCTION LEVELING BLADE DRAWING

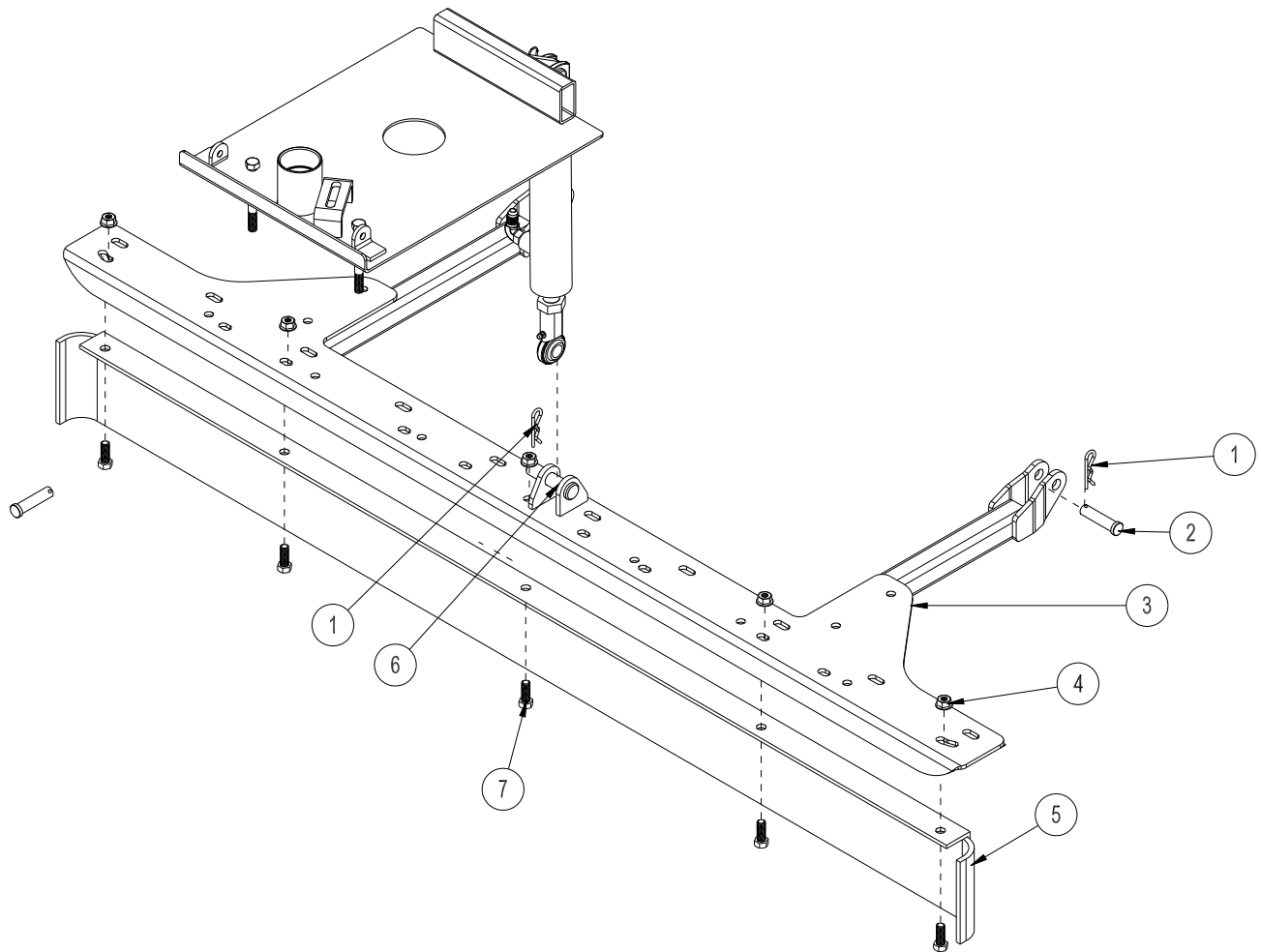

Center Attachment

45-012 CONSTRUCTION LEVELING BLADE PARTS LIST

REF#	PART#	DESCRIPTION	QUANTITY
1	HHP-18	Bridge Pin, $\frac{1}{8}$	3
2	HCP-12-200	Clevis Pin, $\frac{1}{2} \times 2$	2
3	45-116	Center Lift Bar	1
4	HNTL-38-16	Nylon Lock Nut, $\frac{3}{8}$ - 16	5
5	42-097	Leveling Blade	1
6	HCP-58-250	Clevis Pin, $\frac{5}{8} \times 2\frac{1}{2}$	1
7	HB-38-16-100	Hex Bolt, $\frac{3}{8}$ - 16 x 1	5

INSTALLATION INSTRUCTIONS

1. Hex Bolt leveling blade (Ref 5) to center lift bar (Ref 3) using five $\frac{3}{8}$ - 16 x 1 Hex Bolts (Ref 7) and five $\frac{3}{8}$ - 16 Nylon Lock Nuts (Ref 4) as shown on drawing.
2. Attach the center lift bar to a main frame using clevis pin and bridge pin (Ref 1 and 2).
3. Lift center lift bar up or extend cylinder so rod end lines up with the holes on the center of the center lift bar. Use $\frac{5}{8} \times 2\frac{1}{2}$ clevis pin and bridge pin (Ref 6 & 1) to fasten cylinder to cultivator.
4. Turn machine on and test for proper operation.

45-013 FIELD SCARIFIER WITH TINES DRAWING

Center Attachment

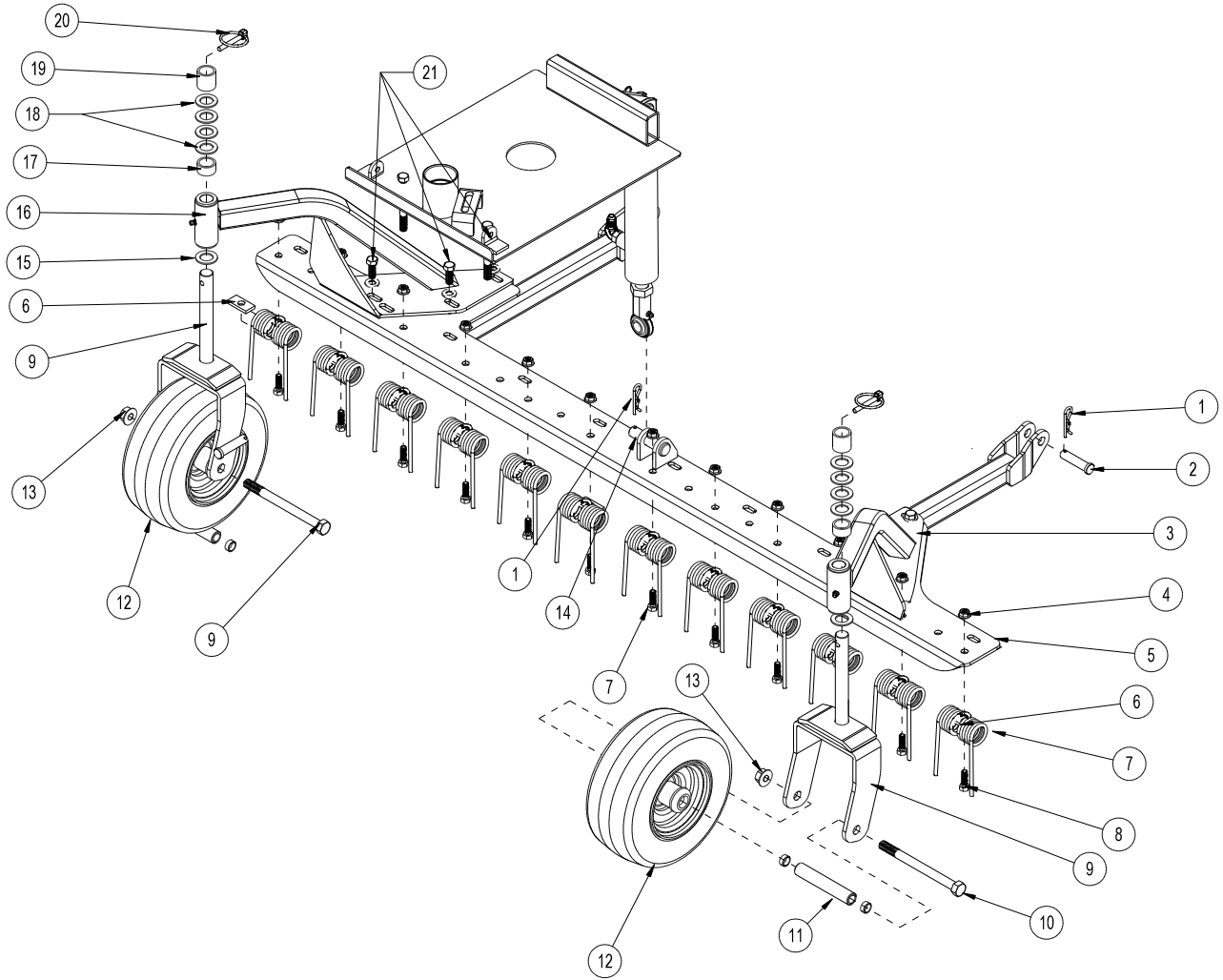

45-013 FIELD SCARIFIER WITH TINES PARTS LIST

REF#	PART#	DESCRIPTION	QUANTITY
1	HHP-18	Bridge Pin, $\frac{1}{8}$	3
2	HCP-12-200	Clevis Pin, $\frac{1}{2} \times 2$	2
3	42-205	Left Castor Wheel Bracket	1
	10-025	Flange Bushing (Part of 42-288)	2
	HG-14-28-180	Grease Fitting, $\frac{1}{4} - 28 \times 180^\circ$ (Part of 42-288)	1
4	HNFL-516-18	Flange Whiz-loc Nut, $\frac{5}{16} - 18$	12
5	45-137	Center Lift Bar	1
6	42-177	Spring Holder	12
7	42-122	Rake Spring	12
8	HB-516-18-150	Hex Bolt, $\frac{5}{16} - 18 \times 1\frac{1}{2}$	12
9	42-204	Castor Fork	2
10	HB-12-13-600	Hex Bolt, $\frac{1}{2} - 13 \times 6$	2
11	33-338	Axle Bearing	2
12	42-202	Tire & Wheel	2
13	HNTL-12-13	Nylon Lock Nut, $\frac{1}{2} - 13$	2
14	HCP-58-250	Clevis Pin, $\frac{5}{8} \times 2\frac{1}{2}$	1
15	HMB-34-14	Machine Bushing, $\frac{3}{4} \times 14GA$	2
16	42-206	Right Castor Wheel Bracket	1
	10-025	Flange Bushing (Part of 42-289)	2
	HG-14-28-180	Grease Fitting, $\frac{1}{4} - 28 \times 180^\circ$ (Part of 42-289)	1
17	42-215	Short Spacer	2
18	HMB-34-10	Machine Bushing, $\frac{3}{4} \times 10GA$	8
19	42-214	Long Spacer	2
20	42-539	Lynch Pin, $\frac{1}{4}$ "	2
21	HB-38-16-100	Hex Bolt, $\frac{3}{8} - 16 \times 1$	6
	HW-38	Flat Washer, $\frac{3}{8}$	6
	HNTL-38-16	Nylon Lock Nut, $\frac{3}{8} - 16$	6

Center Attachment

INSTALLATION INSTRUCTIONS

This accessory comes with only the caster forks assembled.

- Bolt the springs (Ref 7) to the center lift bar (Ref 5) with the spring holder (Ref 6) between center lift bar and the spring. Bolt in place with $\frac{5}{16} - 18 \times 1\frac{1}{2}$ bolt (Ref 8) and Whiz-lock nut (Ref 4).
- Mount the right and left caster wheel brackets (Ref 3 and 16) to the center lift bar (Ref 5) using the rest of $\frac{3}{8} - 16 \times 1$ bolts, washers and nuts (Ref 21).
- Install assembled caster wheel forks (Ref 9-13) onto the right and left caster wheel brackets (Ref 3 and 16).
- Use the machine bushings and spacers (Ref 15, 17-19) as shown to secure the caster forks to the caster wheel brackets. Use the lynch pin (Ref 20) to hold in place.
- Attach the center lift bar to main frame using (Ref 1 and 2) clevis pin and bridge pin.
- Lift center lift bar up or extend cylinder so rod end lines up with the holes on the center of the attachment lift. Use clevis pin and bridge pin (Ref 14 and 1) to fasten cylinder to sand cultivator.
- Adjust caster wheels (Ref 12) by placing the short (Ref 16) or long spacer (Ref 18) on the caster wheel fork before placing the caster wheel assembly into the caster wheel brackets. Be sure both caster wheels are adjusted to the same height.
- Turn machine on and test for proper operation.

45-007 INFIELD SCARIFIER WITH VERTICAL BLADES DRAWING

Center Attachment

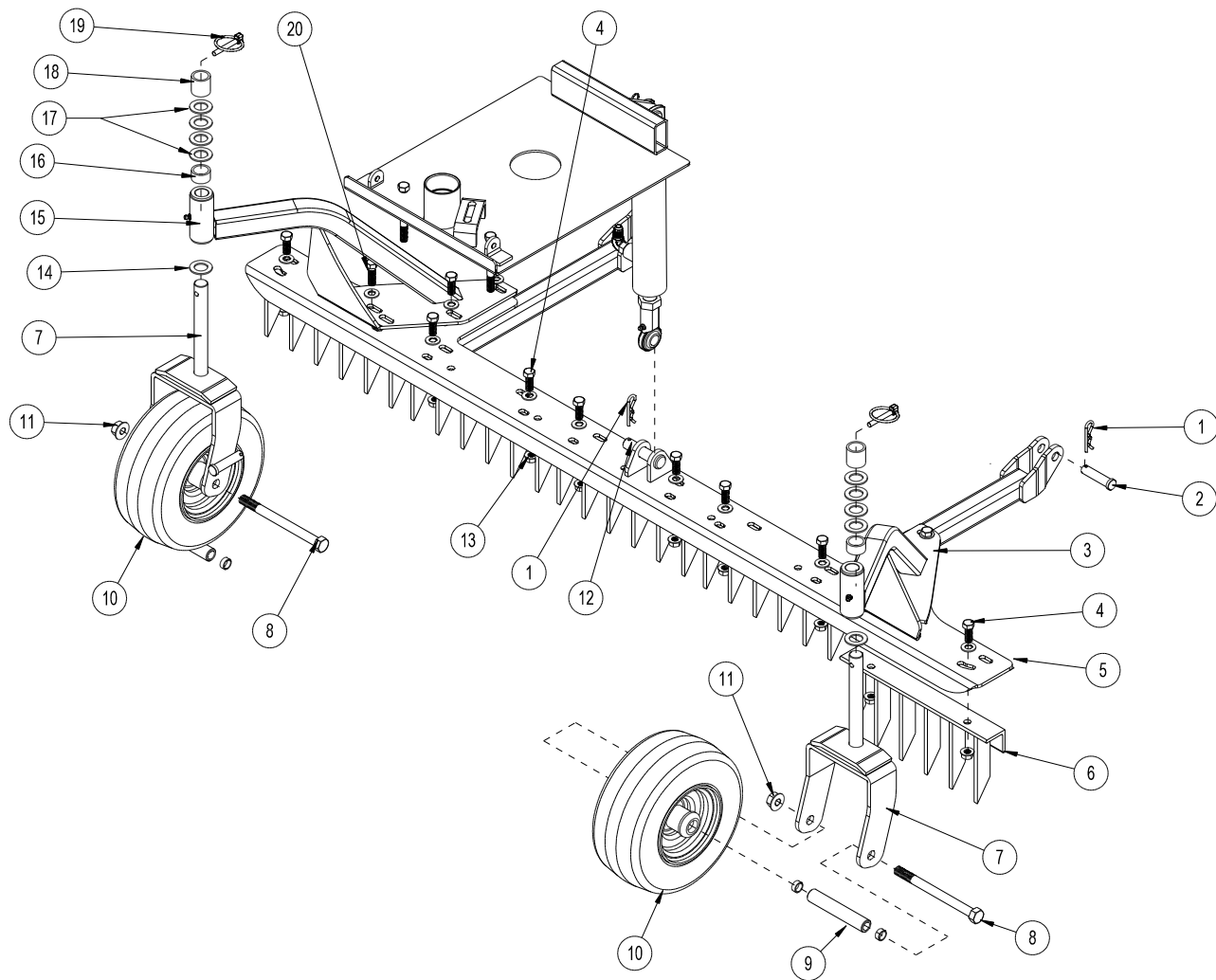

45-007 INFIELD SCARIFIER WITH VERTICAL BLADES PARTS LIST

REF#	PART#	DESCRIPTION	QUANTITY
1	HHP-18	Bridge Pin, $\frac{1}{8}$	3
2	HCP-12-200	Clevis Pin, $\frac{1}{2} \times 2$	2
3	42-205	Left Castor Wheel Bracket	1
	10-025	Flange Bushing (Part of 42-205)	2
	HG-14-28-180	Grease Fitting, $\frac{1}{4} - 28 \times 180^\circ$ (Part of 42-205)	1
4	HB-38-16-100	Hex Bolt $\frac{3}{8} - 16 \times 1$	12
	HW-38	Flat Washer, $\frac{3}{8}$	12
5	45-116	Center Lift Bar	1
6	26-042	Tine Segment	5
7	42-204	Castor Fork	2
8	HB-12-13-600	Hex Bolt, $\frac{1}{2} - 13 \times 6$	2
9	33-338	Axle Bearing	2
10	42-202	Tire and Wheel	2
11	HNTL-12-13	Nylon Lock Nut, $\frac{1}{2} - 13$	2
12	HCP-58-250	Clevis Pin, $\frac{5}{8} \times 2\frac{1}{2}$	1
13	HNTL-38-16	Nylon Lock Nut, $\frac{3}{8} - 16$	14
14	HMB-34-14	Machine Bushing, $\frac{3}{4} \times 14GA$	2
15	42-206	Right Castor Wheel Bracket	1
	10-025	Flange Bushing (Part of 42-206)	2
	HG-14-28-180	Grease Fitting, $\frac{1}{4} - 28 \times 180^\circ$ (Part of 42-206)	1
16	42-215	Short Spacer	2
17	HMB-34-10	Machine Bushing, $\frac{3}{4} \times 10GA$	8
18	42-214	Long Spacer	2
19	42-539	Lynch Pin, $\frac{5}{16}$	2
20	HB-38-16-125	Hex Bolt, $\frac{3}{8} - 16 \times 1\frac{1}{4}$	2
	HW-38	Flat Washer, $\frac{3}{8}$	2

Center Attachment

INSTALLATION INSTRUCTIONS

- Assemble the tine Segments (Ref 6) to the center lift bar (Ref 5) using the $\frac{3}{8} - 16 \times 1$ Hex Bolts, washers and nuts (Ref 4).
- Mount the right and left castor wheel brackets (Ref 3 and 15) to the center lift bar (Ref 5) using the rest of $\frac{3}{8} - 16 \times 1$ Hex Bolts, washers and nuts (Ref 4 & 13). Mount the last two digger blades at this time using the $\frac{3}{8} - 16 \times 1\frac{1}{4}$ Hex Bolts, washers and nuts (Ref 20 & 13).
- Slide the Scarifier under the machine lining up the hydraulic cylinder and the center of the center lift bar.
- Extend hydraulic cylinder all the way down by pushing the lever forward.
- Mount the rod end of the cylinder onto the center lift bar and secure with a clevis pin (Ref 12) and bridge pin (Ref 1).
- Attach the arms on the center lift bar to the main frame on the machine and secure with clevis pin (Ref 2) and bridge pin (Ref 1).
- Turn machine on and test for proper operation.
- Adjust castor wheels (Ref 12) by placing the short (Ref 16) or long spacer (Ref 18) on the castor wheel fork before placing the castor wheel assembly into the castor wheel brackets. Be sure both castor wheels are adjusted to the same height.

45-011 INFIELD SCARIFIER WITH CHISEL BLADES DRAWING

Center Attachment

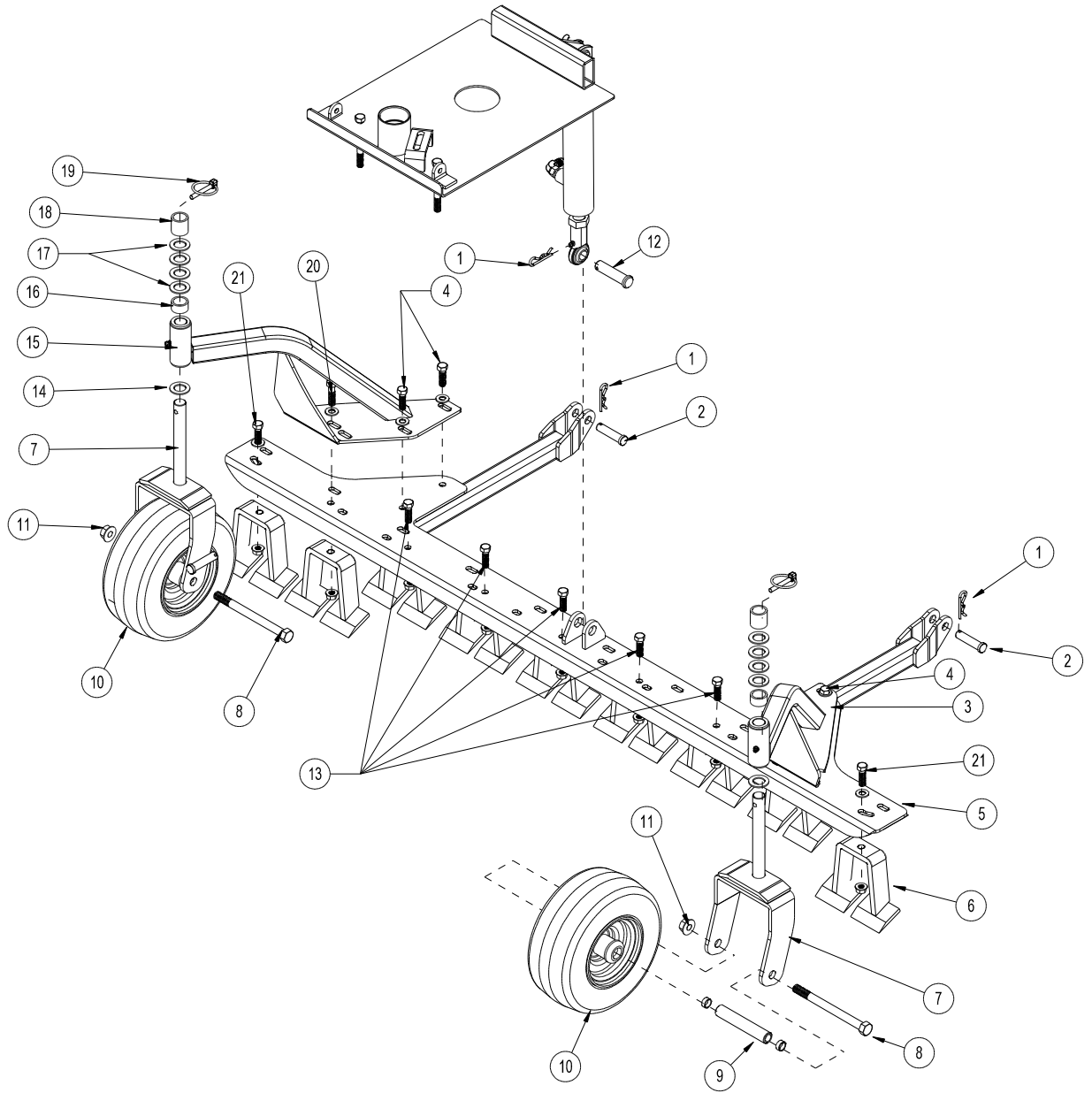

45-011 INFIELD SCARIFIER WITH CHISEL BLADES PARTS LIST

REF#	PART#	DESCRIPTION	QUANTITY
1	HHP-18	Bridge Pin, $\frac{1}{8}$	3
2	HCP-12-200	Clevis Pin, $\frac{1}{2} \times 2$	2
3	42-205	Left Castor Wheel Bracket	1
	10-025	Flange Bushing (Part of 42-205)	2
	HG-14-28-180	Grease Fitting, $\frac{1}{4} - 28 \times 180^\circ$ (Part of 42-205)	1
4	HB-38-16-100	Hex Bolt, $\frac{3}{8} - 16 \times 1$	4
	HW-38	Flat Washer, $\frac{3}{8}$	4
	HNTL-38-16	Nylon Lock Nut, $\frac{3}{8} - 16$	4
5	45-116	Center Lift Bar	1
6	13-114	Digger Blades	9
7	42-204	Castor Fork	2
8	HB-12-13-600	Hex Bolt, $\frac{1}{2} - 13 \times 6$	2
9	33-338	Axle Bearing	2
10	42-202	Tire and Wheel	2
11	HNTL-12-13	Nylon Lock Nut, $\frac{1}{2} - 13$	2
12	HCP-58-250	Clevis Pin, $\frac{5}{8} \times 2\frac{1}{2}$	1
13	HB-38-16-125	Hex Bolt, $\frac{3}{8} - 16 \times 1\frac{1}{4}$	5
	HNTL-38-16	Nylon Lock Nut, $\frac{3}{8} - 16$	5
14	HMB-34-14	Machine Bushing, $\frac{3}{4} \times 14GA$	2
15	42-206	Right Castor Wheel Bracket	1
	10-025	Flange Bushing (Part of 42-206)	2
	HG-14-28-180	Grease Fitting, $\frac{1}{4} - 28 \times 180^\circ$ (Part of 42-206)	1
16	42-215	Short Spacer	2
17	HMB-34-10	Machine Bushing, $\frac{3}{4} \times 10GA$	8
18	42-214	Long Spacer	2
19	42-539	Lynch Pin, $\frac{5}{16}$	2
20	HB-38-16-150	Hex Bolt, $\frac{3}{8} - 16 \times 1\frac{1}{2}$	2
	HW-38	Flat Washer, $\frac{3}{8}$	2
	HNTL-38-16	Nylon Lock Nut, $\frac{3}{8} - 16$	2
21	HB-38-16-125	Hex Bolt, $\frac{3}{8} - 16 \times 1\frac{1}{4}$	2
	HW-38	Flat Washer, $\frac{3}{8}$	2
	HNTL-38-16	Nylon Lock Nut, $\frac{3}{8} - 16$	2

Center Attachment

INSTALLATION INSTRUCTIONS

- Assemble seven digger blades (Ref 6) to the center lift bar (Ref 5) using the $\frac{3}{8} - 16 \times 1\frac{1}{4}$ Hex Bolts, washers and nuts (Ref 21) on the outside slots and $\frac{3}{8} - 16 \times 1$ Hex Bolts and nuts (Ref 13) on the holes. Do not put the two digger blades on that mount with the caster arm hardware (Ref 20).
- Mount the right and left caster wheel brackets (Ref 3 and 15) to the center lift bar (Ref 5) using $\frac{3}{8} - 16 \times 1$ Hex Bolts, washers and nuts (Ref 4). Mount the last two digger blades at this time using the $\frac{3}{8} - 16 \times 1\frac{1}{2}$ Hex Bolts, washers and nuts (Ref 20).
- Slide the Scarifier under the machine lining up the hydraulic cylinder and the center of the center lift bar.
- Extend hydraulic cylinder all the way down by pushing the lever forward.
- Mount the rod end of the cylinder onto the center lift bar and secure with a clevis pin (Ref 12) and bridge pin (Ref 1).
- Attach the arms on the center lift bar to the main frame on the machine and secure with clevis pin (Ref 2) and bridge pin (Ref 1).
- Turn machine on and test for proper operation.
- Adjust castor wheels (Ref 12) by placing the short (Ref 16) or long spacer (Ref 18) on the castor wheel fork before placing the castor wheel assembly into the castor wheel brackets. Be sure both castor wheels are adjusted to the same height.

45-173 SCARIFIER WITH CHISEL BLADES

Center Attachment

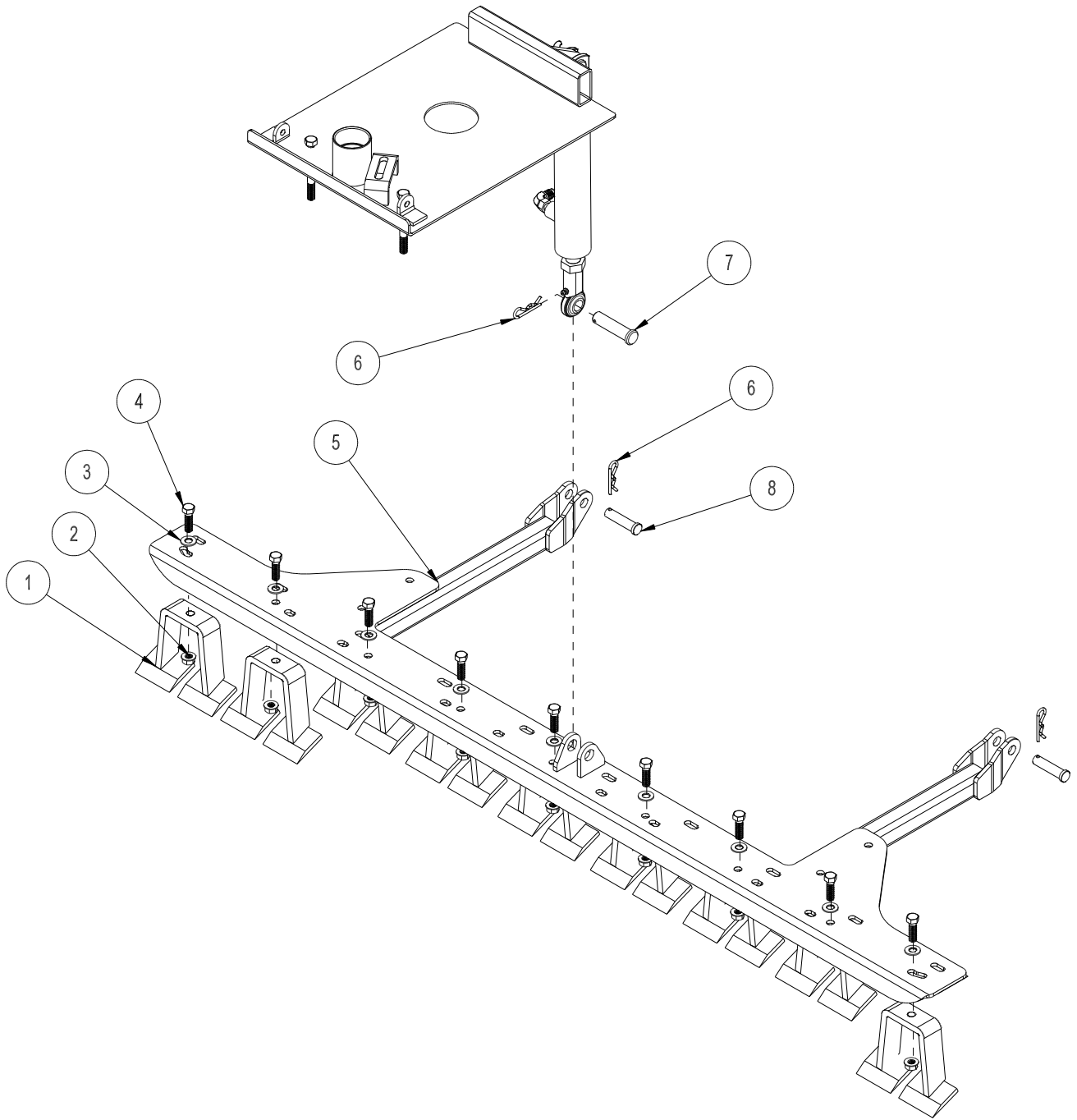

45-173 INFIELD SCARIFIER WITH CHISEL BLADES

REF#	PART#	DESCRIPTION	QUANTITY
1	13-114	Digger Blades	9
2	HNTL-38-16	Nylon Lock Nut, $\frac{3}{8}$ - 16	9
3	HW-38	Flat Washer, $\frac{3}{8}$	9
4	HB-38-16-125	Hex Bolt, $\frac{3}{8}$ - 16 x $1\frac{1}{4}$	9
5	45-116	Center Lift Bar	1
6	HHP-18	Bridge Pin, $\frac{1}{8}$	3
7	HCP-58-250	Clevis Pin, $\frac{5}{8}$ x $2\frac{1}{2}$	1
8	HCP-12-200	Clevis Pin, $\frac{1}{2}$ x 2	2

1. Assemble nine digger blades (Ref 1) to the center lift bar (Ref 5) using the $\frac{3}{8}$ - 16 x $1\frac{1}{4}$ Hex Bolts, washers and nuts (Ref 4,5,6)
2. Slide the Scarifier under the machine lining up the hydraulic cylinder and the center of the center lift bar.
3. Extend hydraulic cylinder all the way down by pushing the lever forward.
4. Mount the rod end of the cylinder onto the center lift bar and secure with a clevis pin (Ref 7) and bridge pin (Ref 6).
5. Attach the arms on the center lift bar to the main frame on the machine and secure with clevis pin (Ref 8) and bridge pin (Ref 6).
6. Turn machine on and test for proper operation.

45-360 INFIELD SCARIFIER WITH LONG VERTICAL BLADES DRAWING

Center Attachment

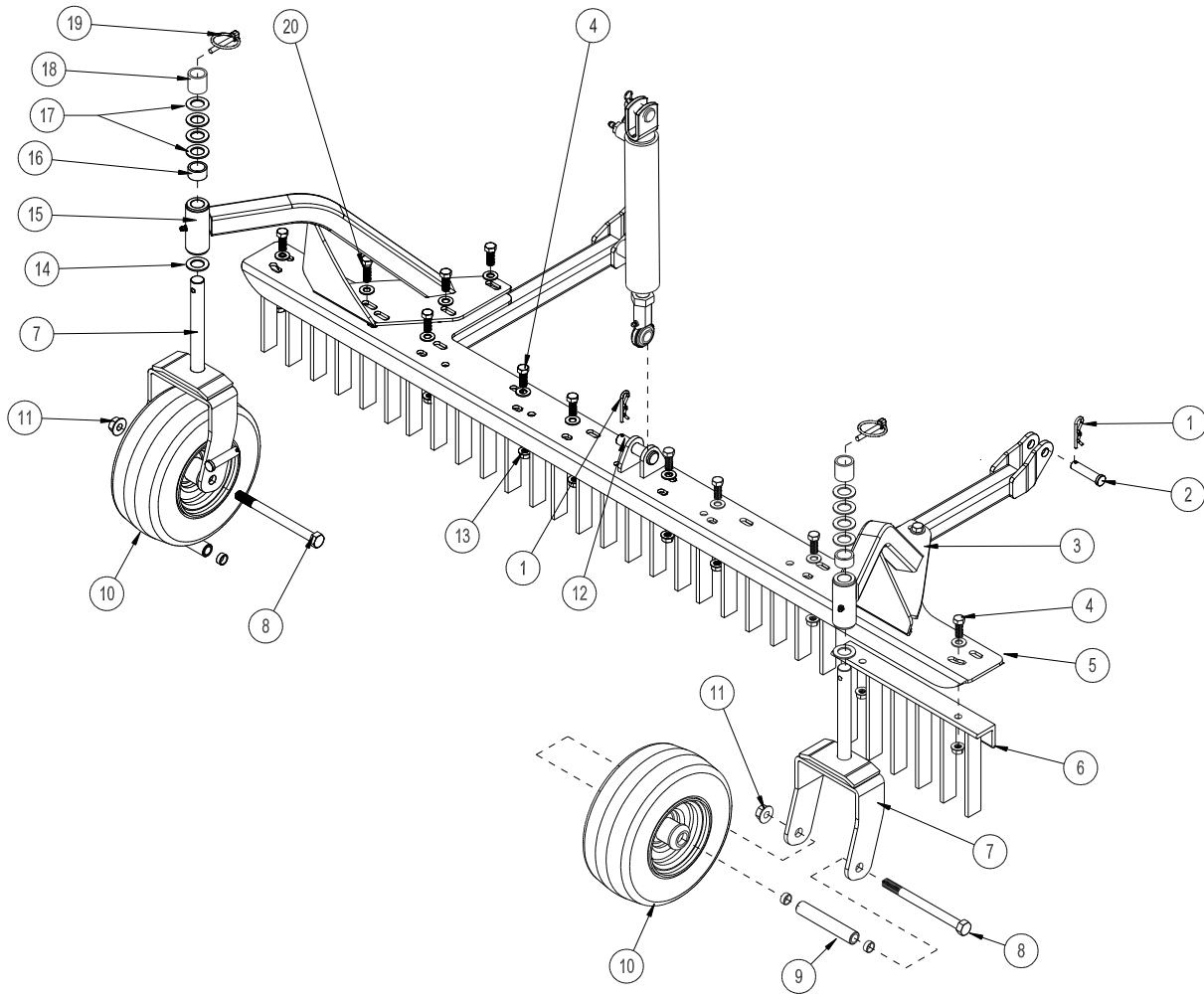

45-360 INFIELD SCARIFIER WITH LONG VERTICAL BLADES PARTS LIST

REF#	PART#	DESCRIPTION	QUANTITY
1	HHP-18	Bridge Pin, $\frac{1}{8}$	3
2	HCP-12-200	Clevis Pin, $\frac{1}{2} \times 2$	2
3	42-288	Left Castor Wheel Bracket	1
	10-025	Flange Bushing (Part of 42-205)	2
	HG-14-28-180	Grease Fitting, $\frac{1}{4} - 28 \times 180^\circ$ (Part of 42-205)	1
4	HB-38-16-100	Hex Bolt, $\frac{3}{8} - 16 \times 1$	12
	HW-38	Flat Washer, $\frac{3}{8}$	12
5	45-116	Center Lift Bar	1
6	42-241	Tine Segment	5
7	42-204	Castor Fork	2
8	HB-12-13-600	Hex Bolt, $\frac{1}{2} - 13 \times 6$	2
9	33-338	Axle Bearing	2
10	42-202	Tire and Wheel	2
11	HNTL-12-13	Nylon Lock Nut, $\frac{1}{2} - 13$	2
12	HCP-58-250	Clevis Pin, $\frac{5}{8} \times 2\frac{1}{2}$	1
13	HNTL-38-16	Nylon Lock Nut, $\frac{3}{8} - 16$	14
14	HMB-34-14	Machine Bushing, $\frac{3}{4} \times 14GA$	2
15	42-289	Right Castor Wheel Bracket	1
	10-025	Flange Bushing (Part of 42-206)	2
	HG-14-28-180	Grease Fitting, $\frac{1}{4} - 28 \times 180^\circ$ (Part of 42-206)	1
16	42-215	Short Spacer	2
17	HMB-34-10	Machine Bushing, $\frac{3}{4} \times 10GA$	8
18	42-214	Long Spacer	2
19	42-539	Lynch Pin, $\frac{5}{16}$	2
20	HB-38-16-125	Hex Bolt, $\frac{3}{8} - 16 \times 1\frac{1}{4}$	2
	HW-38	Flat Washer, $\frac{3}{8}$	2

Center Attachment

INSTALLATION INSTRUCTIONS

- Assemble the tine Segments (Ref 6) to the center lift bar (Ref 5) using the $\frac{3}{8} - 16 \times 1$ Hex Bolts, washers and nuts (Ref 4).
- Mount the right and left castor wheel brackets (Ref 3 and 15) to the center lift bar (Ref 5) using the rest of $\frac{3}{8} - 16 \times 1$ Hex Bolts, washers and nuts (Ref 4 & 13). Mount the last two digger blades at this time using the $\frac{3}{8} - 16 \times 1\frac{1}{4}$ Hex Bolts, washers and nuts (Ref 20 & 13).
- Slide the Scarifier under the machine lining up the hydraulic cylinder and the center of the center lift bar.
- Extend hydraulic cylinder all the way down by pushing the lever forward.
- Mount the rod end of the cylinder onto the center lift bar and secure with a clevis pin (Ref 12) and bridge pin (Ref 1).
- Attach the arms on the center lift bar to the main frame on the machine and secure with clevis pin (Ref 2) and bridge pin (Ref 1).
- Turn machine on and test for proper operation.
- Adjust castor wheels (Ref 12) by placing the short (Ref 16) or long spacer (Ref 18) on the castor wheel fork before placing the castor wheel assembly into the castor wheel brackets. Be sure both castor wheels are adjusted to the same height.

45-195 GRADER BLADE DRAWING

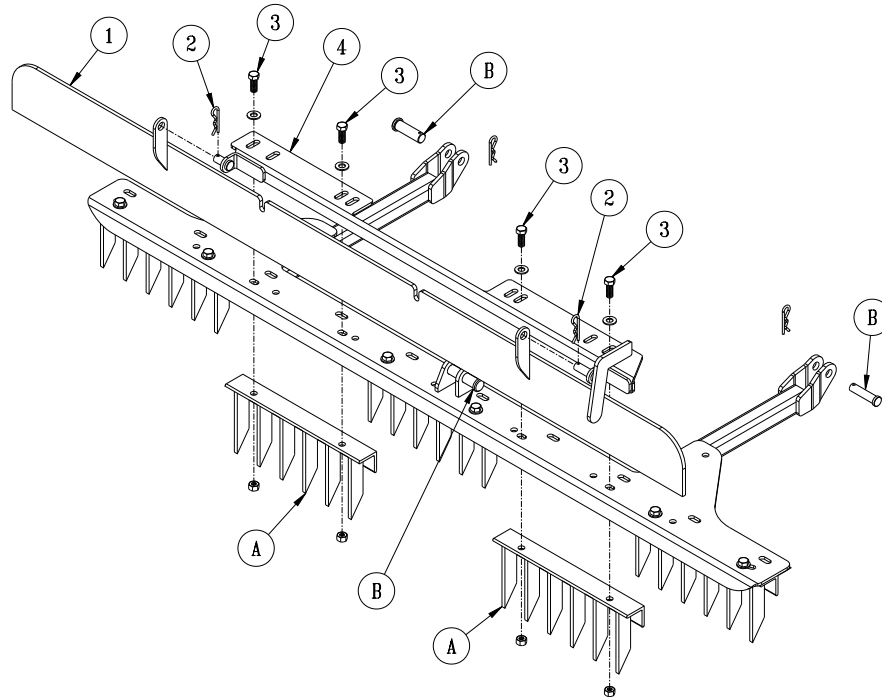

Center Attachment

45-195 GRADER BLADE CARRIER DRAWINGS

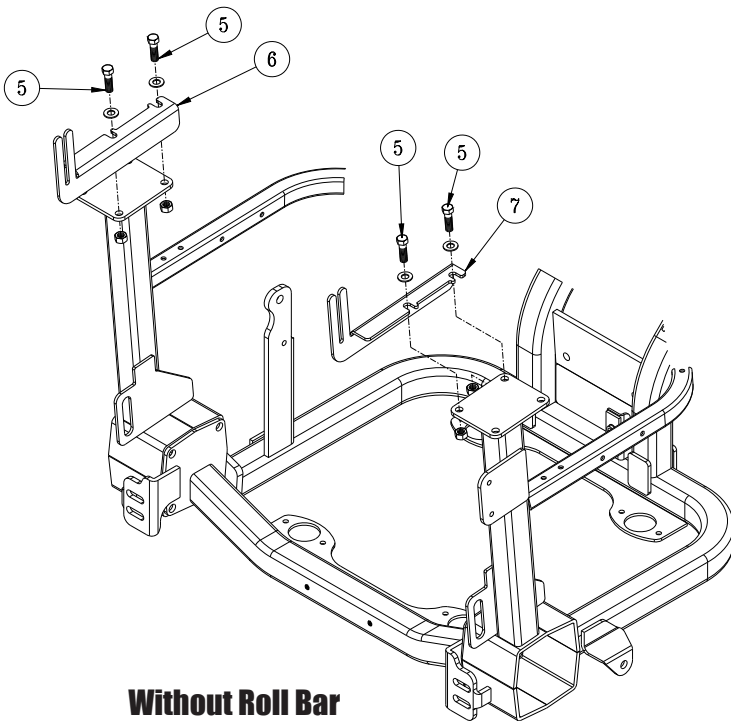

Without Roll Bar

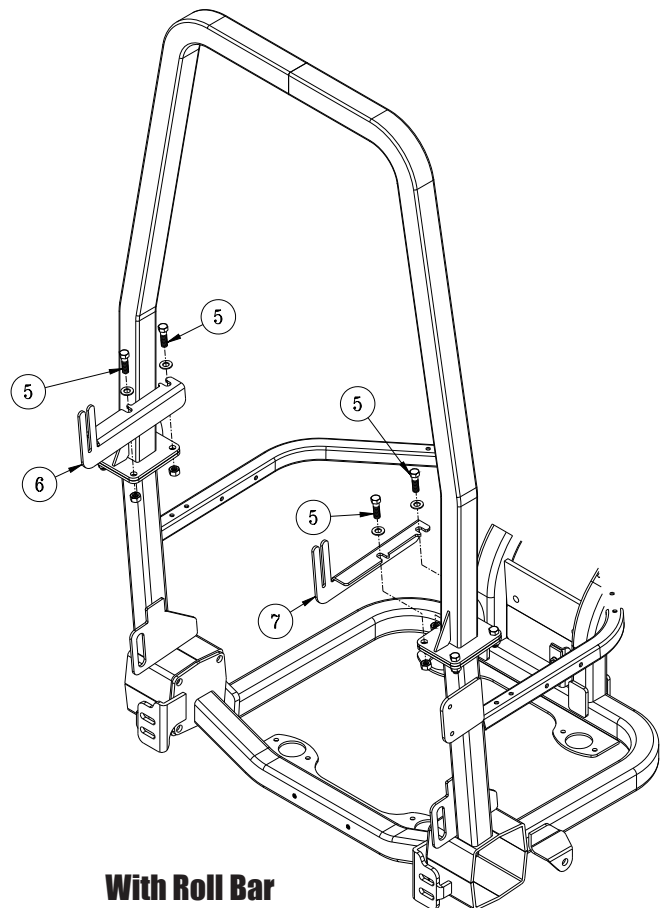

With Roll Bar

45-195 GRADER BLADE PARTS LIST

REF#	PART#	DESCRIPTION	QTY
1	42-207	Grader Blade	1
2	HHP-18	Bridge Pin, $\frac{1}{8}$	2
3	HB-38-16-125	Hex Bolt, $\frac{3}{8}$ - 16 x $1\frac{1}{4}$	4
	HW-38	Flat Washer, $\frac{3}{8}$	4
4	45-190	Blade Mount	1
5	HB-716-14-150	Hex Bolt, $\frac{7}{16}$ - 14 x $1\frac{1}{2}$	4
	HNTL-716-14	Nylon Lock Nut, $\frac{7}{16}$ - 14	4
	HW-716	Flat Washer, $\frac{7}{16}$	4
6	45-191	LH Carrier Bracket	1
7	45-192	RH Carrier Bracket	1

45-195 GRADER BLADE INSTALLATION INSTRUCTIONS

1. Lower center attachment to the ground and remove the 3 Clevis Pins(**Ref. B**).
2. Remove the (4) Hex Bolts holding each of Blades(**Ref A**) to the right and left of the center blade. Set the Blades and (4) Nylon Lock Nuts aside.
3. Place the Blade Mount(**Ref. 4**) on top of the attachment frame, lining up the slots where the Hex Bolts were removed. Replace the removed Hex Bolts with the included $\frac{3}{8}$ -16 x $1\frac{1}{4}$ Hex Bolts and $\frac{3}{8}$ Flat Washers(**Ref 3**). Reinstall the Blades(**Ref. A**) and secure using the $\frac{3}{8}$ -16 Nylon Lock Nuts that were set aside.
4. Check all hardware for tightness.
5. Reinstall center attachment. Slide the Grader Blade(**Ref. 1**) onto the pins, as illustrated, and secure using the Bridge Pins(**Ref 2**).
- 6a. *To install the Carrier Brackets on a machine **without** a roll bar:*
Mount the RH Carrier Bracket(**Ref. 7**) and LH Carrier Bracket(**Ref. 6**) to the to the ROPS towers using the inside set of holes. Secure each Bracket using the $\frac{7}{16}$ -14 x $1\frac{1}{2}$ Hex Bolts, $\frac{7}{16}$ Flat Washers and $\frac{7}{16}$ -14 Nylon Lock Nuts.
- 6b. *To install the Carrier Brackets on a machine **with** a roll bar:*
Remove the (4) inside Hex Bolts, position each Carrier Bracket(**Refs. 6 & 7**) over the holes and use the $\frac{7}{16}$ -14 x $1\frac{1}{2}$ Hex Bolts, $\frac{7}{16}$ Flat Washers and $\frac{7}{16}$ -14 Nylon Lock Nuts to secure.
7. When placing the Grader Blade in the Carriers point the mounting tabs downward as shown in the photo below.

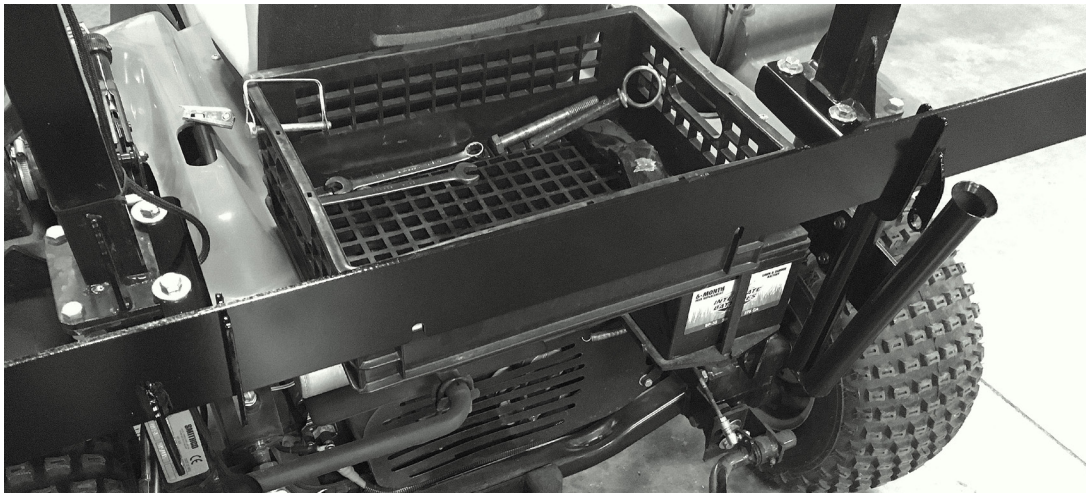

45-177 NAIL SCARIFIER WITH CASTOR WHEELS DRAWING

Center Attachment

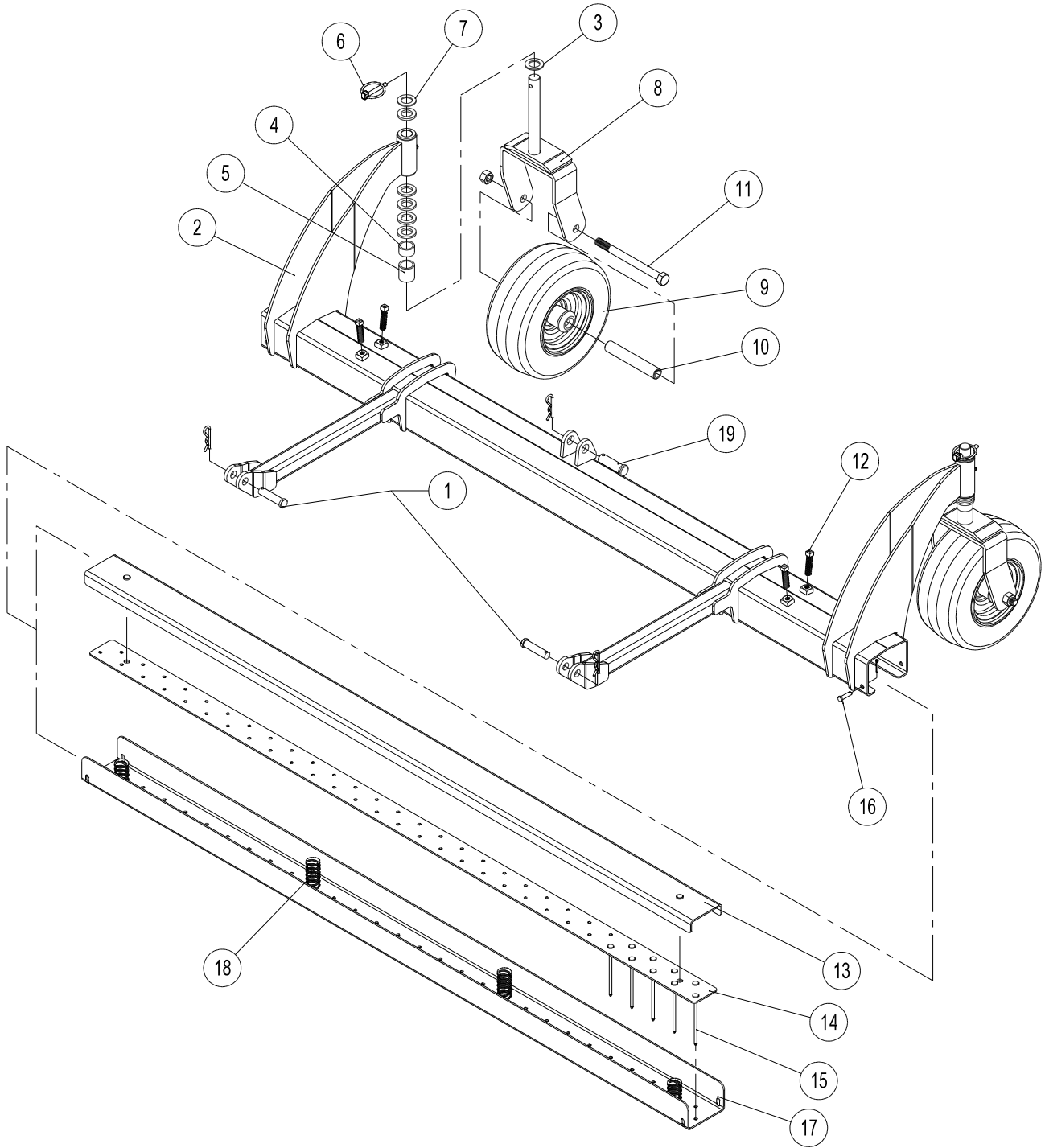

45-177 NAIL SCARIFIER WITH CASTOR WHEELS PARTS LIST

REF#	PART#	DESCRIPTION	QUANTITY
1	HCP-12-200	Clevis Pin, 1/2 x 2	2
	HHP-18	Bridge Pin, 1/8	2
2	45-171	Nail Scarifier Frame	1
	10-025	Flange Bushing (Part of 43-171)	4
	HG-14-28-180	Grease Fitting, 1/4 - 28 x 180° (Part of 43-171)	2
3	HMB-34-14	Machine Bushing, 3/4 x 14GA	2
4	42-215	Short Spacer	2
5	42-214	Long Spacer	2
6	42-539	Lynch Pin, 1/4"	2
7	HMB-34-10	Machine Bushing, 3/4 x 10GA	12
8	42-204	Castor Fork	2
9	42-202	Tire & Wheel	2
10	33-338	Axle Bearing	2
11	HB-12-13-600	Hex Bolt, 1/2 - 13 x 6	2
	HNTL-12-13	Nylon Lock Nut, 1/2 - 13	2
12	HSSQS-38-16-150	SS Sq. Head Set Screw, 3/8 - 16 x 1 1/2	4
	HN-38-16	Hex Nut, 3/8 - 16	4
13	45-172	Nail Channel Cover	1
14	45-170	Nail Plate	1
15	9028	Spiral Shank Nail, 7GA x 4"	57
16	HCP-14-075	Clevis Pin, 1/4 x 3/4	1
	HP-332-075	Cotter Pin, 3/8 x 3/4	1
17	45-169	Nail Channel	1
18	43-175	Compression Spring	4
19	HCP-58-200	Clevis Pin, 5/8 x 2	1
	HHP-18	Bridge Pin, 1/8	1

Center Attachment

45-015 MOTORIZED BRUSH DRAWING

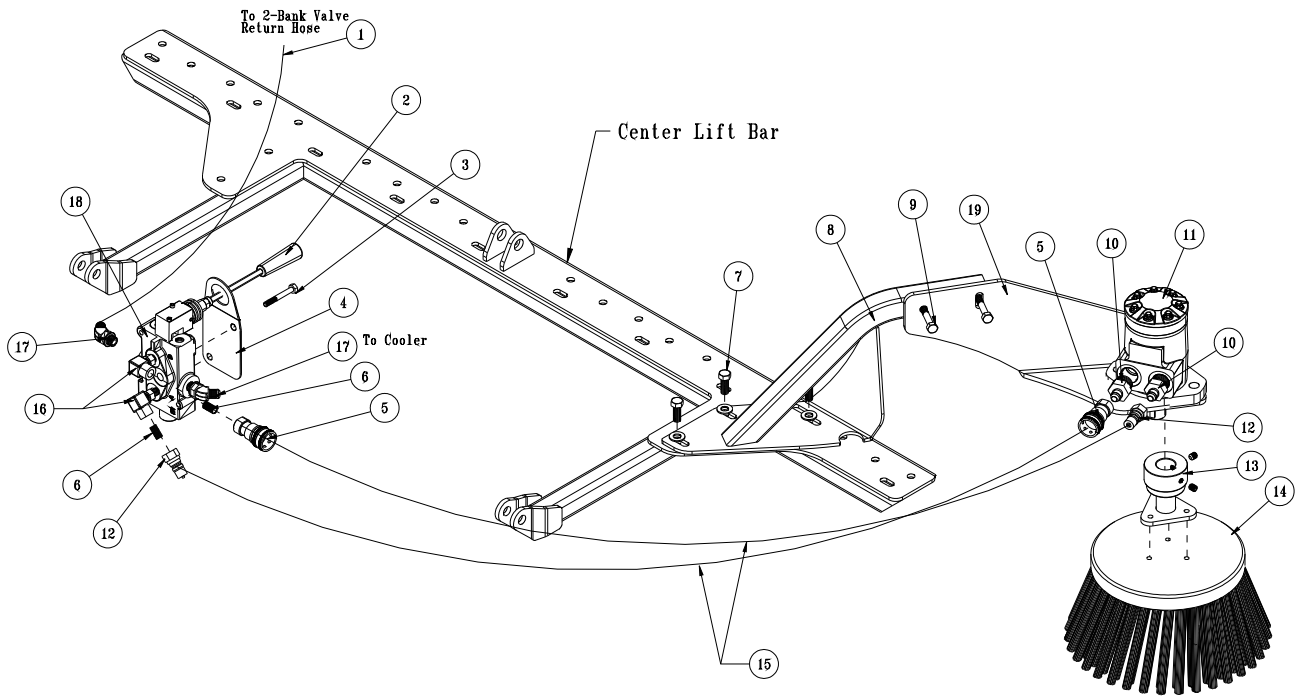

Center Attachment

REF#	PART #	DESCRIPTION	QUANTITY
1	45-143	Hydraulic Hose 21"	1
2	78-417	Handle	1
3	HB-516-18-200	Hex Bolt $\frac{5}{16}$ - 18 x 2	2
	HNTL-516-18	Nylon Lock Nut $\frac{5}{16}$ -18	2
4	45-127	Valve Mount Plate	1
5	78-230	Coupler $\frac{1}{4}$ "	2
6	18-011	Black Pipe Close Nipple $\frac{1}{4}$	2
7	HB-38-16-100	Hex Bolt $\frac{3}{8}$ -16 x 1	3
	HW-38	Washer $\frac{3}{8}$	3
	HNTL-38-16	Nylon Lock Nut $\frac{3}{8}$ - 16	3
8	45-152	Brush Motor Support	1
9	HB-516-18-200	Hex Bolt $\frac{5}{16}$ - 18 x 2	2
	HNFL-516-18	Flange Whiz-Loc Nut $\frac{5}{16}$ -18	2
10	18-331	Adapter	2
11	45-149	Hydraulic Motor	1
12	78-231	Nipple, $\frac{1}{4}$	2
13	45-150	Hub Assembly	1
	HB-14-20-150	Hex Bolt $\frac{1}{4}$ - 20 x $1\frac{1}{2}$	3
	HNTL-14-20	Nylon Lock Nut $\frac{1}{4}$ - 20	3
14	45-144	8" Polypro Side Broom	1
15	45-142	Hydraulic Hose 42"	2
16	23-018	O-ring Elbow	2
17	18-188	45° Elbow	2
18	45-148	Single Bank Valve	1
19	45-151	Brush Motor Mount	1

INSTALLATION INSTRUCTIONS

1. This product only fits on a Sand Star I(45-001) and Sand Star II (45-002).
2. Center lift bar must be installed on our machine. This kit does not come with a lift bar.
3. If your center lift bar has castor wheels on it, you must remove the castor wheels and brackets.
4. Install Brush Motor Support (Ref 8) on your right side of center lift arm using the holes where the caster wheel would Hex Bolt to. Hex Bolt in place with hardware (Ref 7).
5. Place Hub Assembly (Ref 13) on brush (Ref 14) with the (Ref 13) hardware.
6. Place motor (Ref 11) on Motor mount (Ref 19) and then mount that assembly to the Brush Motor Support (Ref 8).
7. Connect the brush and hub assembly to the motor and tighten set screws.
8. Place adapter (Ref 10) into motor. Then place the Coupler (Ref 5) on the inside adapter and the nipple (Ref 12) on the outside adapter.
9. Assemble the valve as shown in the drawing.
10. The Valve assembly mounts on the right front fender. The valve goes underneath the fender with the handle pointing outward. The valve mount plate (Ref 4) mounts on the outside of the fender.
11. Using the valve mount as a template, Measure in approximately **4.25 inches** from edge of right fender and mark. Line valve mount up with contour of the fender and the right side of the line you just marked. Trace holes onto fiberglass. Drill holes out.
12. Mount the Single Bank Hydraulic Valve (Ref # 18) to the Valve Mount (Ref # 4) as illustrated, using the two $\frac{5}{16}$ - 18 x 2 Hex Bolts (Ref # 3). Secure with the two Nylon Lock Nuts. Connect the Straight Handle (Ref # 2) to the Valve.
13. Connect 42" hoses (Ref 15) from the motor to the valve. Connect the 21" hose from the valve to the cooler. The return hose on the 2-bank valve connects to the single bank valve.
14. Test operation of the broom before using on turf.



Center Attachment



45-175 ADJUSTABLE DISC EDGER DRAWING

Center Attachment

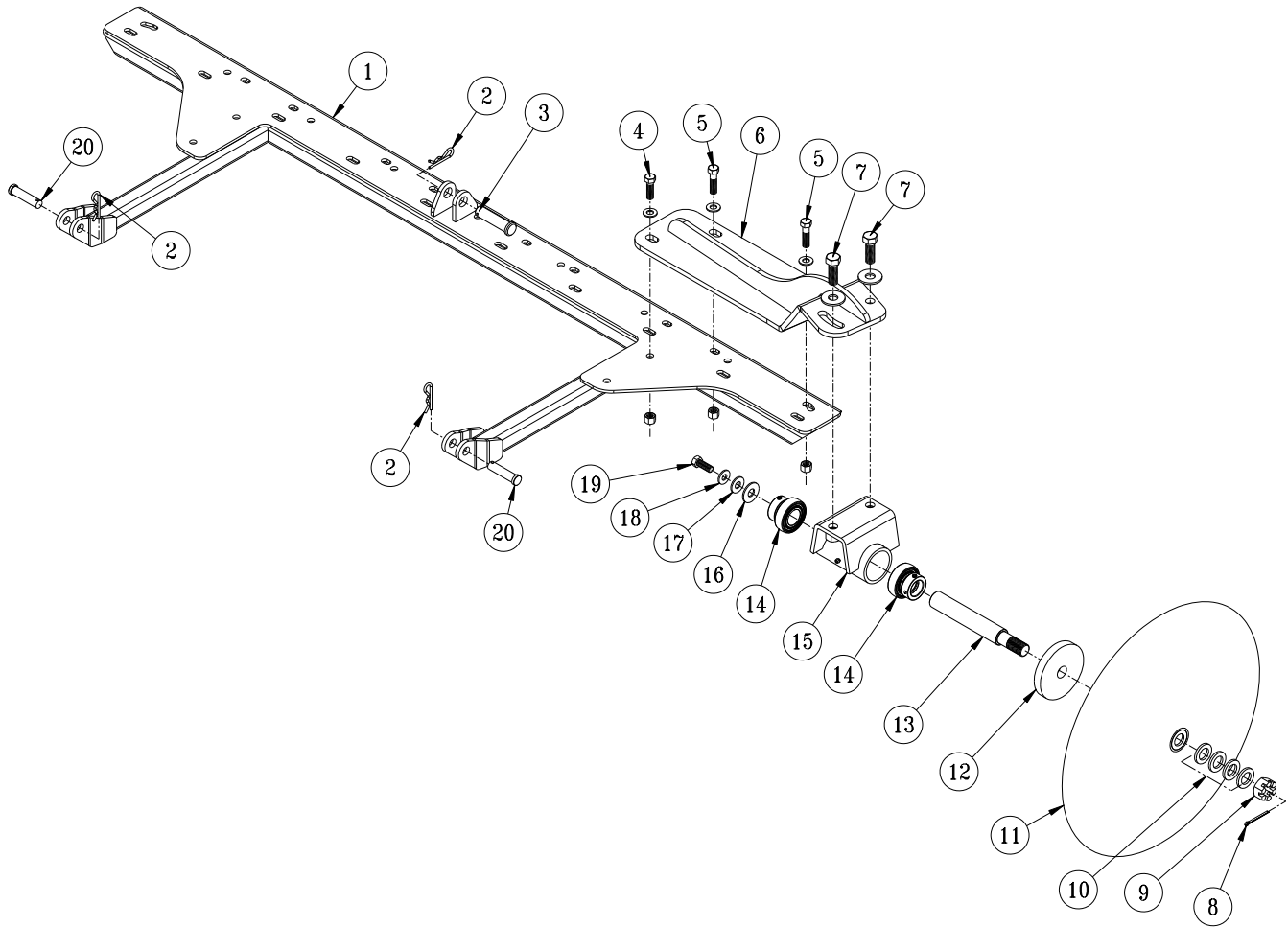

45-175 ADJUSTABLE DISC EDGER PARTS LIST

REF#	PART#	DESCRIPTION	QUANTITY
1	45-116	Center Lift	1
2	HHP-18	Bridge Pin, $\frac{1}{8}$	3
3	HCP-58-250	Clevis Pin, $\frac{5}{8} \times 2\frac{1}{2}$	1
4	HB-38-16-125	Hex Bolt, $\frac{3}{8}$ - 16 x $1\frac{1}{4}$	1
	HW-38	Flat Washer, $\frac{3}{8}$	1
	HNTL-38-16	Nylon Lock Nut, $\frac{3}{8}$ -16	1
5	HB-38-16-150	Hex Bolt, $\frac{3}{8}$ - 16 x $1\frac{1}{2}$	2
	HW-38	Flat Washer, $\frac{3}{8}$	2
	HNTL-38-16	Nylon Lock Nut, $\frac{3}{8}$ - 16	2
6	45-166	Edger Mount	1
7	HB-12-13-150	Hex Bolt, $\frac{1}{2}$ - 13 x $1\frac{1}{2}$	2
	HW-12	Flat Washer, $\frac{1}{2}$	2
	HNTL-12-13	Nylon Lock Nut, $\frac{1}{2}$ - 13	2
8	HP-18-150	Cotter Pin, $\frac{1}{8} \times 1\frac{1}{2}$	1
9	HNA-34-16	Axle Nut, $\frac{3}{4}$ - 16	1
10	HMB-34-10	Machine Bushing, $\frac{3}{4} \times 10GA$	4
11	13-204	Disc	1
12	13-205	Disc Flange	1
13	13-206	Spindle Shaft	1
14	13-391	Bearing and Collar	2
15	13-203	Spindle	1
	HG-14-28-180	Grease Fitting	1
16	HW-716	Flat Washer $\frac{7}{16}$	1
17	HWL-38	Lock Washer, $\frac{3}{8}$	1
18	HW-516	Flat Washer, $\frac{5}{16}$	1
19	HB-38-16-100	Hex Bolt, $\frac{3}{8}$ -16 x 1	1
20	HCP-12-200	Clevis Pin, $\frac{1}{2} \times 2$	2

Center Attachment

INSTALLATION INSTRUCTIONS

- For initial assembly, Hex Bolt Spindle Assembly (**Ref. 13 thru 19**) to the Edger Mount (**Ref. 6**). Use the $\frac{1}{2}$ - 13 Hex Bolts, Washers and Nylon Lock Nuts (**Ref. 7**) to secure.
- Slide the Disc Flange (**Ref. 12**) on the Spindle Shaft (**Ref. 13**) up to the shoulder. Then place the Disc (**Ref.11**) onto the shaft, orienting the concave side towards the Spindle followed by the four Machine Bushings (**Ref. 10**), and the axle nut (**Ref. 9**).
- Tighten Axle Nut, insert and clinch the Cotter Pin (**Ref. 8**).
- Connect the Edger Mount onto the Center Lift (**Ref.1**) using the $\frac{3}{8}$ Hex Bolts, Washers and Nylon Lock Nuts (**Refs. 4 & 5**), with the $1\frac{1}{4}$ " Hex Bolt (**Ref. 4**) going into the last hole on the Mount Plate.
- The Edger mounts under the center of the trap rake.
- Start the engine and lower the cylinder for the attachment lift FULLY. Stop engine.
- Slide Edger under the trap rake from the right side.
- Position the lift arms on the attachment lift assembly to the lift brackets on the machine. Hold in place with $\frac{1}{2} \times 2$ clevis pin and bridge pins (**Refs. 2 & 20**).
- Attach the cylinder to the center tab on the Center Lift using the $\frac{5}{8} \times 2\frac{1}{2}$ Clevis Pin and Bridge Pin (**Refs. 2 & 3**).
- Start engine and test lift and Edger to make sure all works well.

42-391Q 72"(183CM) ProBrush TOURNAMENT RAKE DRAWING

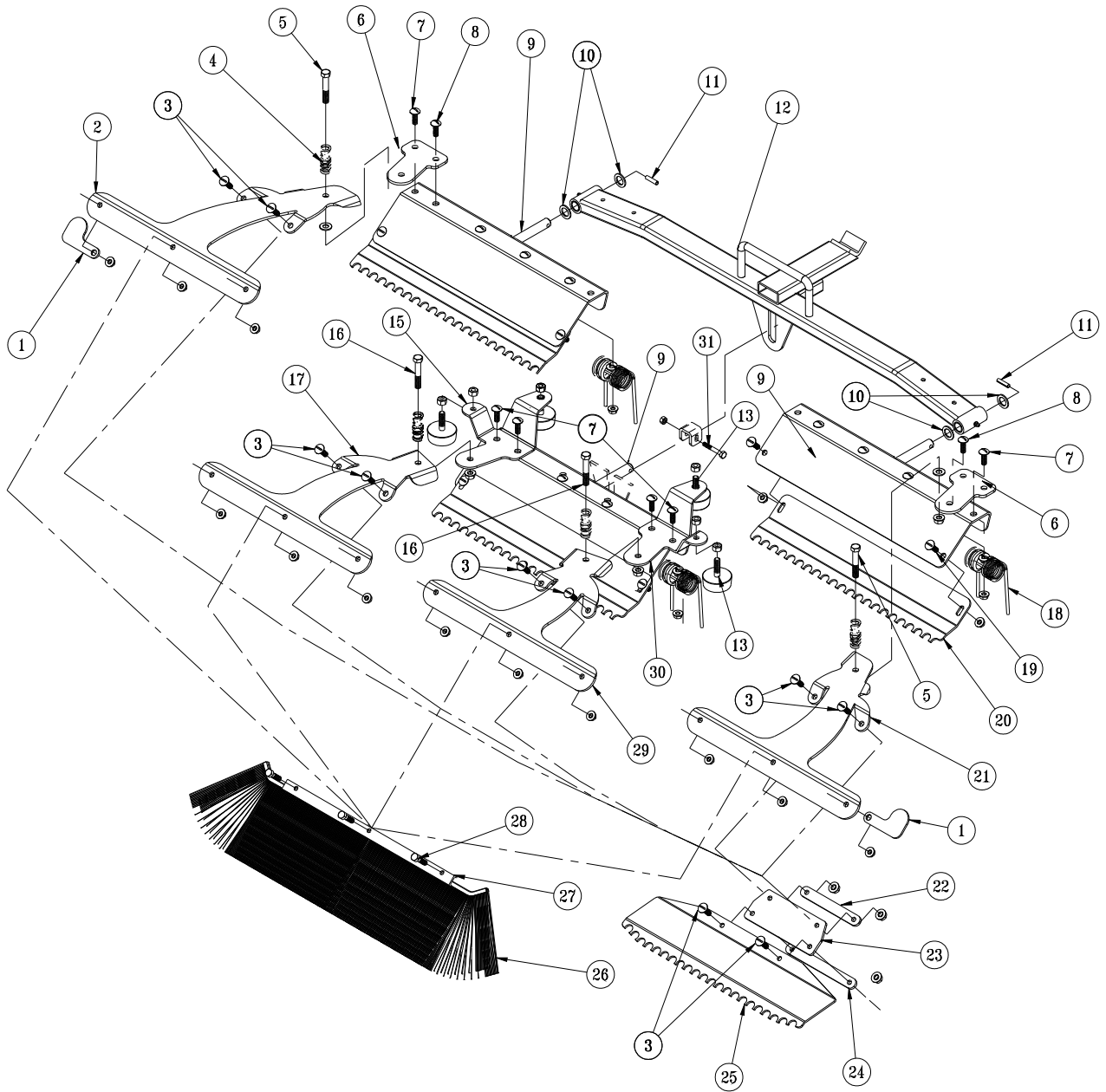

Rear Attachment

42-391Q 72"(183CM) ProBrush TOURNAMENT RAKE PARTS LIST

REF#	PART#	DESCRIPTION	QUANTITY
1	42-489	Tip Guard	2
2	42-397	Outside Brush Arm, LH	1
3	HSTP-516-18-100	Phillip Truss Head Screw, $\frac{5}{16}$ - 18 x 1	16
	HNFL-516-18	Flange Whiz-Loc Nut, $\frac{5}{16}$ - 18	16
4	11-055	Compression Spring	4
5	HB-38-16-275	Hex Bolt, $\frac{3}{8}$ - 16 x 2 $\frac{3}{4}$	2
	HW-38	Flat Washer, $\frac{3}{8}$	2
	HNTL-38-16	Nylon Lock Nut, $\frac{3}{8}$ - 16	2
6	42-396	Outside Brush Arm Mount	2
7	HSTP-516-18-100	Phillips Truss Head Screw, $\frac{5}{16}$ - 18 x 1	4
	HNFL-516-18	Flange Whiz-Loc Nut, $\frac{5}{16}$ - 18	4
8	HSTP-516-18-125	Phillips Truss Head Screw, $\frac{5}{16}$ - 18 x 1 $\frac{1}{4}$	12
	HNFL-516-18	Flange Whiz-Loc Nut, $\frac{5}{16}$ - 18	12
9	42-140	Outside Rake	3
10	HMB-58-14	Machine Bushing $\frac{5}{8}$ x 14GA	4
11	HRP-14-100	Roll Pin $\frac{1}{4}$ x 1	2
12	43-154	Draw Bar	1
	20-018	Oilite Bushing (comes with 43-154)	4
13	50-081	Rubber Bumper	4
	HNFL-38-16	Flange Whiz-Loc Nut, $\frac{3}{8}$ - 16	6
15	42-399	Brush Arm Mount, LH	1
16	HB-38-16-250	Hex Bolt, $\frac{3}{8}$ - 16 x 2 $\frac{1}{2}$	2
	HNTL-38-16	Nylon Lock Nut, $\frac{3}{8}$ - 16	2
17	42-454	Inside Brush Arm, LH	1
18	42-122	Rake Spring	12
	42-177	Spring Holder	12
19	HSTP-516-18-075	Phillip Truss Head Screw, $\frac{5}{16}$ - 18 x $\frac{3}{4}$	6
	HNFL-516-18	Flange Whiz-Loc Nut $\frac{5}{16}$ - 18	6
20	42-171	Groomer Blades	3
21	42-393	Outside Brush Arm, RH	1
22	42-105	Top Strap	4
23	42-107	Matting	4
24	42-106	Bottom Strap	4
25	42-170	Finishing Blades	4
26	42-466	Brush, 21"	4
27	42-465	Brush Clamp	4
28	HB-516-18-125	Hex Bolt, $\frac{5}{16}$ - 18 x 1 $\frac{1}{4}$ - 18	12
29	42-453	Inside Brush Arm, RH	1
30	42-398	Brush Arm Mount, RH	1
31	HB-14-20-175	Hex Bolt, $\frac{1}{4}$ - 20 x 1 $\frac{3}{4}$	1
	HNTL-14-20	Nylon Lock Nut, $\frac{1}{4}$ - 20	1

42-391Q 72"(183CM) ProBRUSH TOURNAMENT RAKE DRAWING

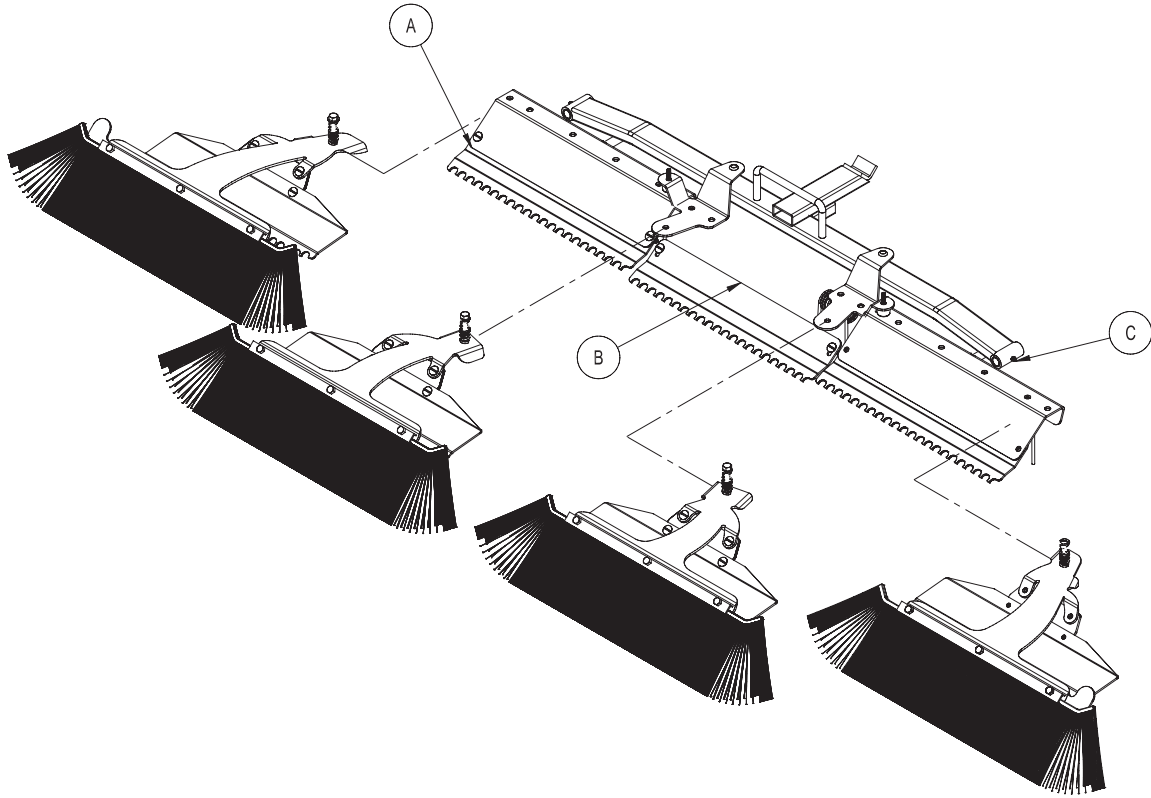

Fig. 1

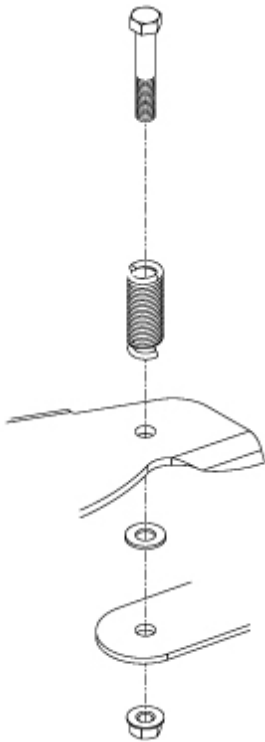

Fig. 2



Fig. 3

Rear Attachment

PROBRUSH TOURNAMENT RAKE ASSEMBLY INSTRUCTIONS

Your **ProBrush TOURNAMENT RAKE** comes mostly assembled.

1. Before assembly please note the two Brush/Finish Blade Assemblies (Refs A & C in Fig.1) that are mounted on the outside (RH & LH) have flat washers that are between the Brush Arms (Refs 2 & 21) and the Brush Arm Mount (Ref 6).
2. Also please note the placement of the Brush/Finish Blade Assemblies as illustrated in Fig 1. They must be mounted as illustrated to work as intended.
3. Begin assembling your **ProBrush TOURNAMENT RAKE** by inserting the Outside and Center Groomer Blade Assemblies (Refs A, B & C in Fig.1) in their locations as illustrated. Secure the Outside Assemblies with the $\frac{1}{4}$ " Pin (Ref 11) and the Center Assembly with the $\frac{1}{4}$ " x $1\frac{3}{4}$ " Hex Bolt and Nylon Lock Nut (Ref 31).
4. Mount the Brush/Finish Blade Assemblies to the Brush Arm Mounts (Refs 6, 30 & 15) as illustrated using the $\frac{3}{8}$ " x $2\frac{1}{2}$ " Hex Bolts and Nylon Lock Nuts. Assemble with the Springs (Ref 4) as shown in Fig. 2. Please note that the $\frac{3}{8}$ " Flat Washers are used only on the Outside Assemblies. Secure when assembled.
5. Mount your **ProBrush TOURNAMENT RAKE** to the trap rake quick hitch. Position the Rake so it is centered and equal distance away from the right and left hand tires (2-3 inches). Fig. 4. Once positioned, set the Adjustment Screws on the Hitch so they touch the trap rake hitch. Fig. 5.
6. Run machine and test for operation of the Rake by raising and lowering the assembly and with rake down turn sharp corners in both directions to ensure rake is not contacting the tires. Test Rake in sand to ensure tire tracks are covered when turning sharp corners. If the tire tracks are not covered by the Rake, turn the Adjustment Screws on the Rake Hitch so the rake comes closer to the tires when turning. For reference see Fig. 4 and 5 below.

NOTE:

The Outside Brush/Finish Blade Assemblies may be rotated 180° for transport and for working in narrow areas, as illustrated in Fig.3 on the facing page.

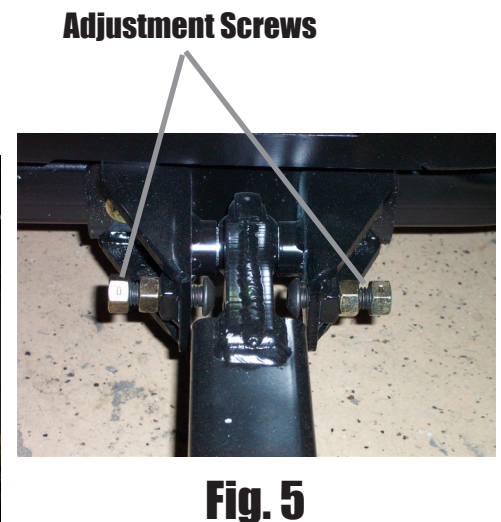
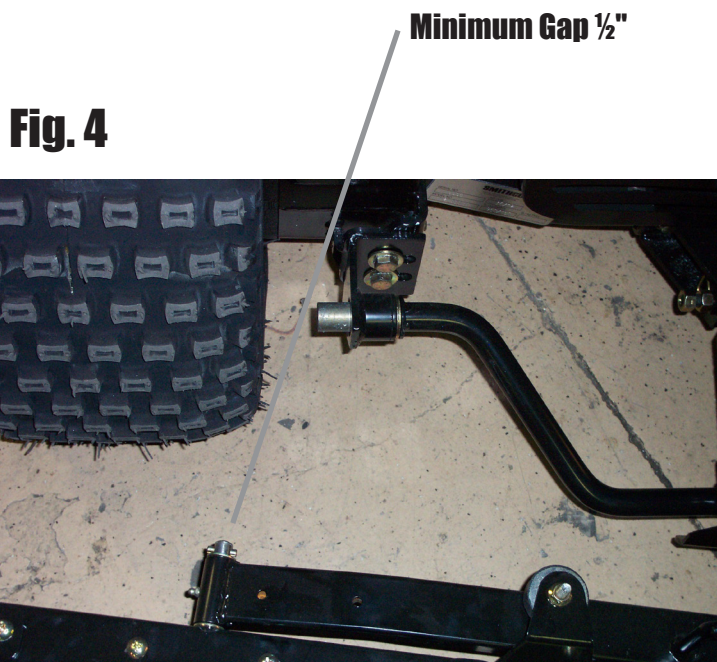

42-392Q 84"(213CM) ProBRUSH TOURNAMENT RAKE DRAWING

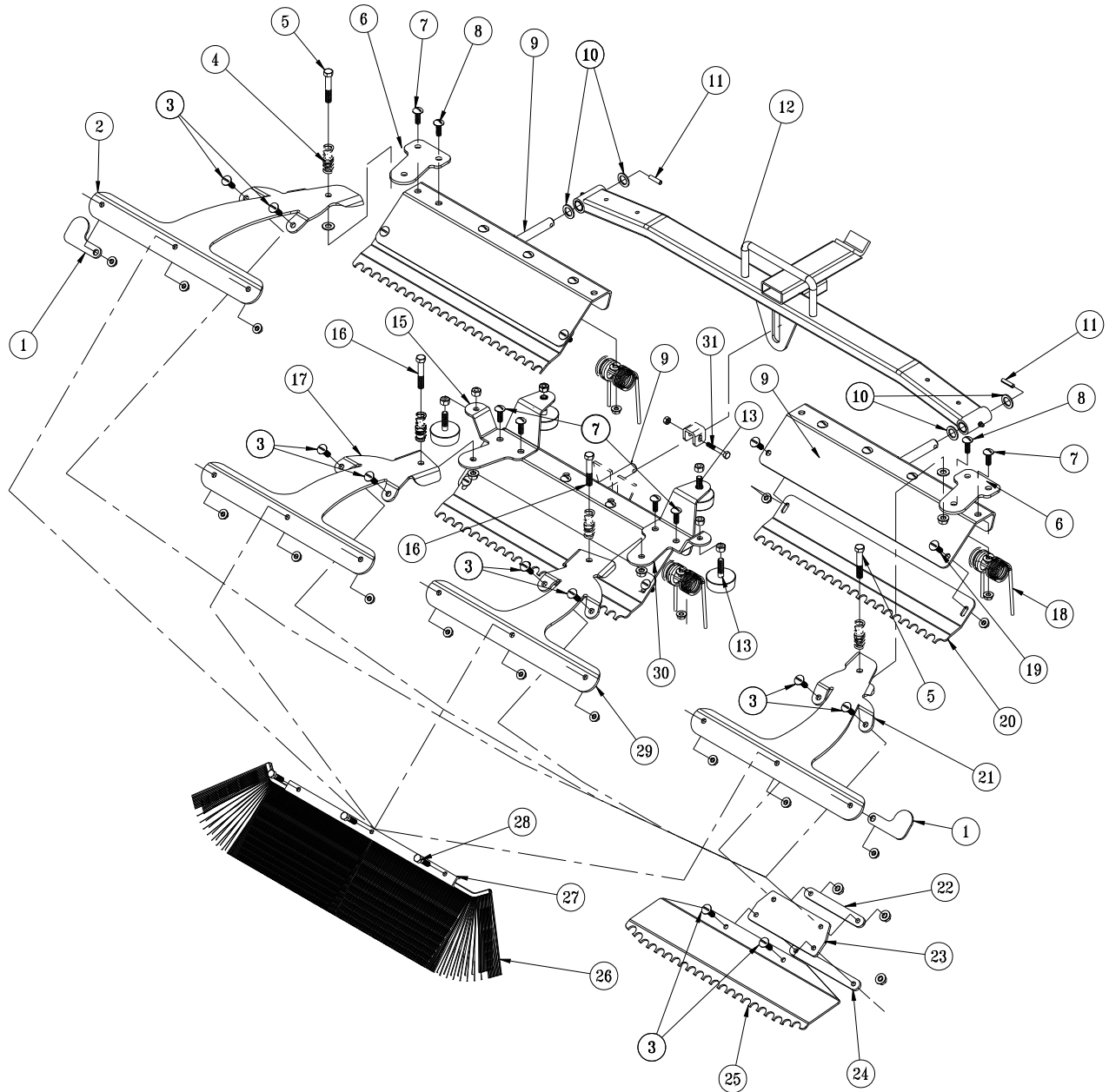

Rear Attachment

42-392Q 84"(213CM) ProBrush TOURNAMENT RAKE PARTS LIST

REF#	PART#	DESCRIPTION	QUANTITY
1	42-489	Tip Guard	2
2	42-397	Outside Brush Arm, LH	1
3	HSTP-516-18-100	Phillip Truss Head Screw, $\frac{5}{16}$ - 18 x 1	16
	HNFL-516-18	Flange Whiz-Loc Nut, $\frac{5}{16}$ - 18	16
4	11-055	Compression Spring	4
5	HB-38-16-250	Hex Bolt, $\frac{3}{8}$ - 16 x $2\frac{1}{2}$	2
	HW-38	Flat Washer, $\frac{3}{8}$	2
	HNTL-38-16	Nylon Lock Nut, $\frac{3}{8}$ - 16	2
6	42-396	Outside Brush Arm Mount	2
7	HSTP-516-18-100	Phillips Truss Head Screw, $\frac{5}{16}$ - 18 x 1	4
	HNFL-516-18	Flange Whiz-Loc Nut, $\frac{5}{16}$ - 18	4
8	HSTP-516-18-125	Phillips Truss Head Screw, $\frac{5}{16}$ - 18 x $1\frac{1}{4}$	12
	HNFL-516-18	Flange Whiz-Loc Nut, $\frac{5}{16}$ - 18	12
9	42-102	84" Outside Rake	3
10	HMB-58-14	Machine Bushing, $\frac{5}{8}$ x 14GA	4
11	HRP-14-100	Roll Pin, $\frac{1}{4}$ x 1	2
12	43-144	84" Draw Bar	1
13	50-081	Rubber Bumper	4
	HNFL-38-16	Flange Whiz-Loc Nut, $\frac{3}{8}$ - 16	6
15	42-399	Brush Arm Mount, LH	1
16	HB-38-16-250	Hex Bolt, $\frac{3}{8}$ - 16 x $2\frac{1}{2}$	2
	HNTL-38-16	Nylon Lock Nut, $\frac{3}{8}$ - 16	2
17	42-454	Inside Brush Arm, LH	1
18	42-122	Rake Spring	12
	42-177	Spring Holder	12
19	HSTP-516-18-075	Phillip Truss Head Screw, $\frac{5}{16}$ - 18 x $\frac{3}{4}$	6
	HNFL-516-18	Flange Whiz-Loc Nut, $\frac{5}{16}$ - 18	6
20	42-129	Groomer Blades	3
21	42-393	Outside Brush Arm, RH	1
22	42-105	Top Strap	4
23	42-107	Matting	4
24	42-106	Bottom Strap	4
25	42-135	Finishing Blades	4
26	42-466	Brush, 21"	4
27	42-465	Brush Clamp	4
28	HB-516-18-125	Hex Bolt, $\frac{5}{16}$ - 18 x $1\frac{1}{4}$	12
	HNFL-516-18	Flange Whiz-Loc Nut, $\frac{5}{16}$ - 18	12
29	42-453	Inside Brush Arm, RH	1
30	42-398	Brush Arm Mount, RH	1
31	HB-14-20-175	Hex Bolt, $\frac{1}{4}$ - 20 x $1\frac{3}{4}$	1
	HNTL-14-20	Nylon Lock Nut, $\frac{1}{4}$ - 20	1

42-392Q 84"(213CM) ProBRUSH TOURNAMENT RAKE DRAWING

Fig. 1

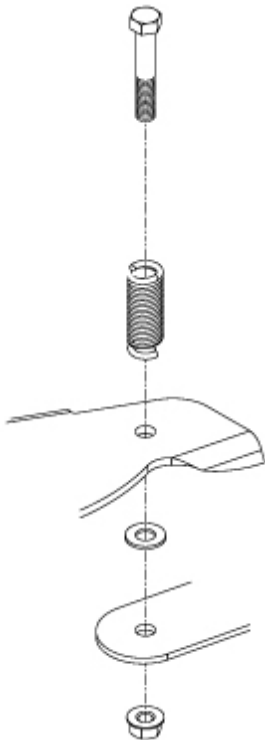
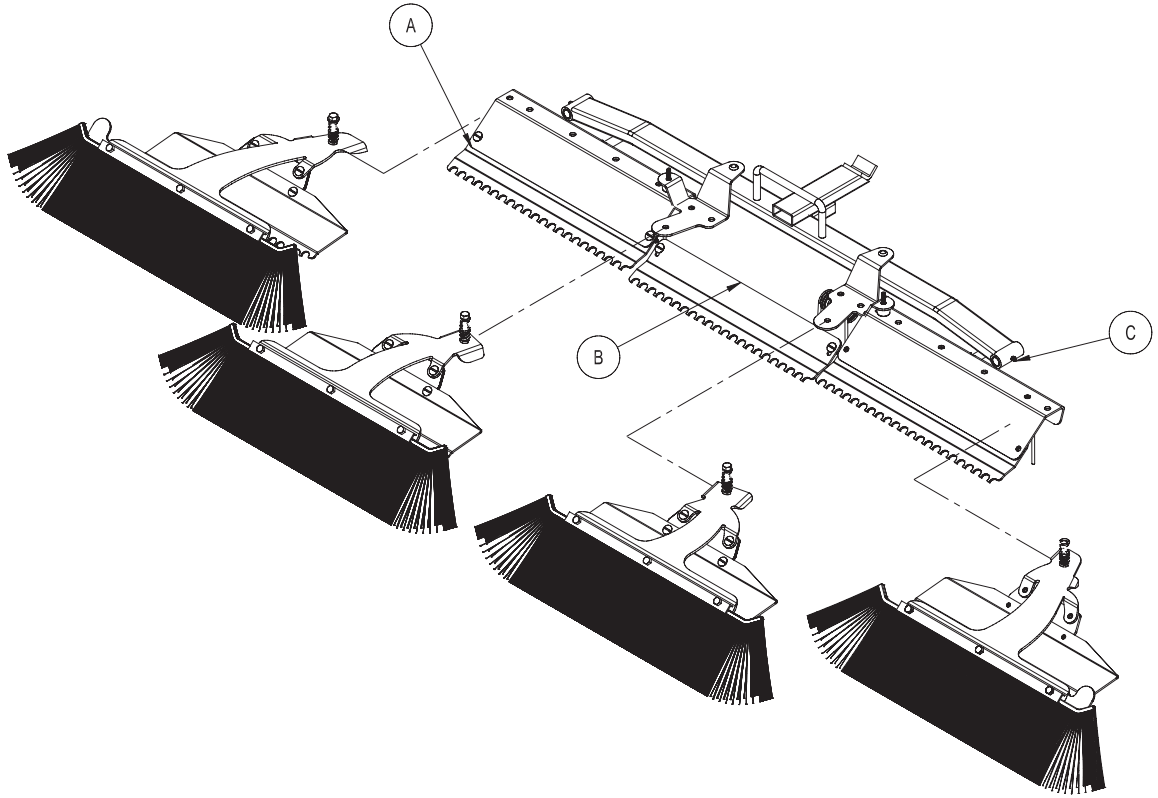

Fig. 2



Fig. 3

Rear Attachment

PROBRUSH TOURNAMENT RAKE ASSEMBLY INSTRUCTIONS

Your **ProBrush TOURNAMENT RAKE** comes mostly assembled.

1. Before assembly please note the two Brush/Finish Blade Assemblies (Refs A & C in Fig.1) that are mounted on the outside (RH & LH) have flat washers that are between the Brush Arms (Refs 2 & 21) and the Brush Arm Mount (Ref 6).
2. Also please note the placement of the Brush/Finish Blade Assemblies as illustrated in Fig 1. They must be mounted as illustrated to work as intended.
3. Begin assembling your **ProBrush TOURNAMENT RAKE** by inserting the Outside and Center Groomer Blade Assemblies (Refs A, B & C in Fig.1) in their locations as illustrated. Secure the Outside Assemblies with the $\frac{1}{4}$ " Pin (Ref 11) and the Center Assembly with the $\frac{1}{4}$ " x $1\frac{3}{4}$ " Hex Bolt and Nylon Lock Nut (Ref 31).
4. Mount the Brush/Finish Blade Assemblies to the Brush Arm Mounts (Refs 6, 30 & 15) as illustrated using the $\frac{3}{8}$ x $2\frac{1}{2}$ Hex Bolts and Nylon Lock Nuts. Assemble with the Springs (Ref 4) as shown in Fig. 2. Please note that the $\frac{3}{8}$ " Flat Washers are used only on the Outside Assemblies. Secure when assembled.
5. Mount your **ProBrush TOURNAMENT RAKE** to the trap rake quick hitch. Position the Rake so it is centered and equal distance away from the right and left hand tires (2-3 inches). Fig. 4. Once positioned, set the Adjustment Screws on the Hitch so they touch the trap rake hitch. Fig. 5.
6. Run machine and test for operation of the Rake by raising and lowering the assembly and with rake down turn sharp corners in both directions to ensure rake is not contacting the tires. Test Rake in sand to ensure tire tracks are covered when turning sharp corners. If the tire tracks are not covered by the Rake, turn the Adjustment Screws on the Rake Hitch so the rake comes closer to the tires when turning. For reference see Fig. 4 and 5 below.

NOTE:

The Outside Brush/Finish Blade Assemblies may be rotated 180° for transport and for working in narrow areas, as illustrated in Fig.3 on the facing page.

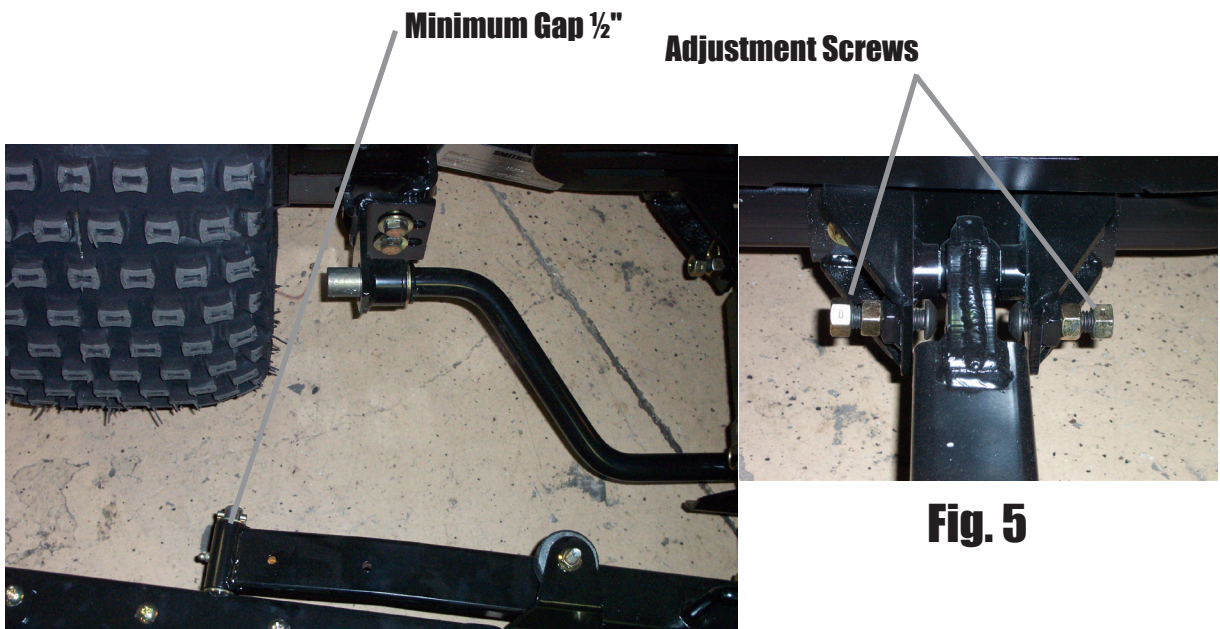
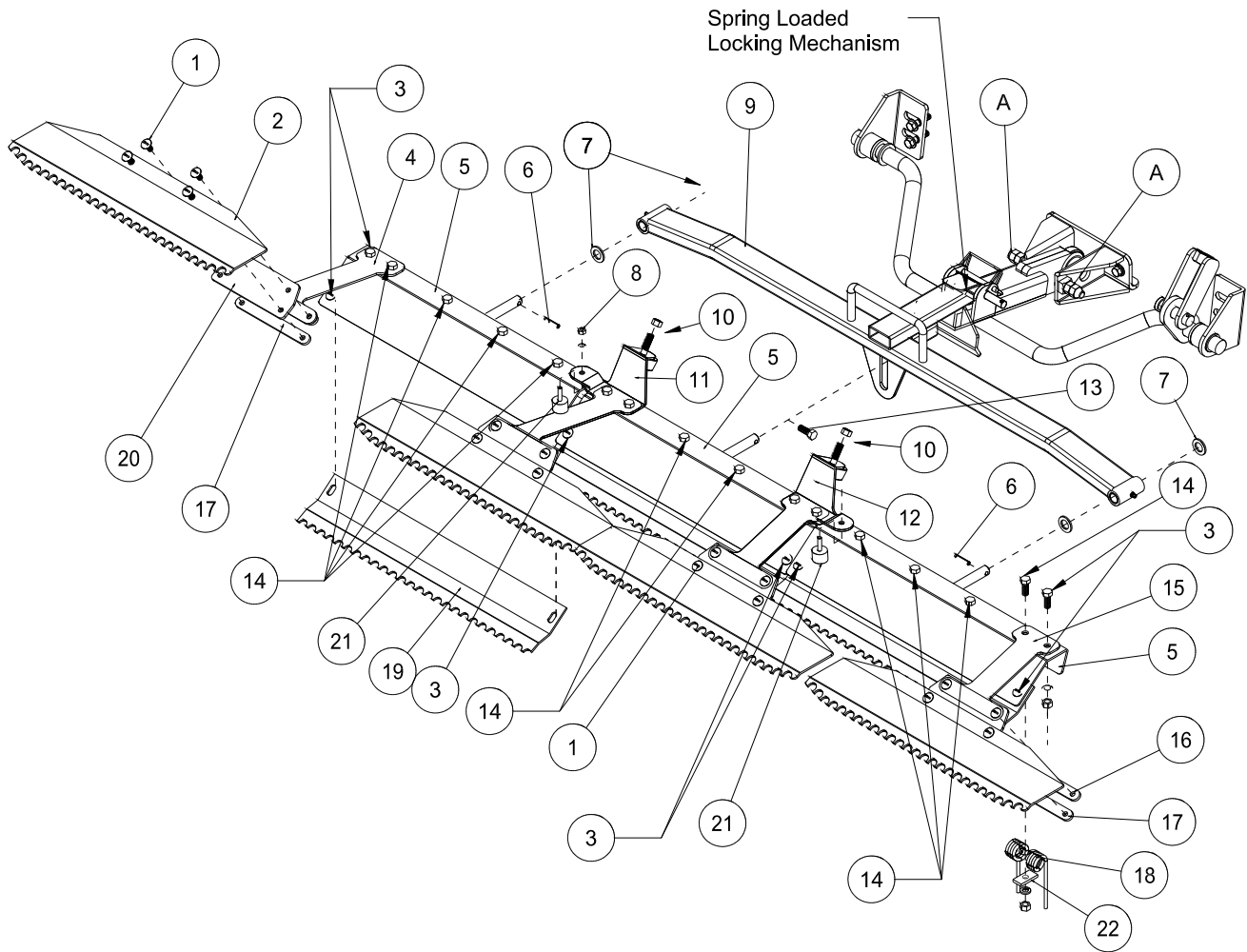

Fig. 4

Fig. 5

42-130Q 84" (213CM) MILD STEEL TOURNAMENT RAKE DRAWING



Rear Attachment

42-130Q 84" (213CM) MILD STEEL TOURNAMENT RAKE PARTS LIST

REF#	PART#	DESCRIPTION	QUANTITY
1	HSTP-516-18-100	Phillips Machine Screw, $\frac{5}{16}$ - 18 x 1	16
	HNFL-516-18	Flange Whiz-Loc Nut, $\frac{5}{16}$ - 18	16
2	42-135	Finishing Blades	4
3	HSTP-516-18-075	Phillips Machine Screw, $\frac{5}{16}$ - 18 x $\frac{3}{4}$	8
	HNFL-516-18	Flange Whiz-Loc Nut, $\frac{5}{16}$ - 18	8
4	42-111	Left Outside Mount	1
5	42-102	Outside Rake	3
6	HRP-14-100	Roll Pin, $\frac{1}{4}$ x 1	2
7	HMB-58-14	Machine Bushing, $\frac{5}{8}$ x 14GA	4
8	HNC-14-20	Cap Nut, $\frac{1}{4}$ - 20	2
	HWL-14	Lock Washer, $\frac{1}{4}$	2
9	43-144	Draw Bar	1
10	50-081	Rubber Bumper	2
11	42-110	Left Inside Mount	1
12	42-108	Inside Trowel Mount	1
13	HB-14-20-175	Hex Bolt, $\frac{1}{4}$ - 20 x $1\frac{3}{4}$	1
	HNTL-14-20	Nylon Lock Nut, $\frac{1}{4}$ - 20	1
14	HSTP-516-18-125	Phillips Machine Screw, $\frac{5}{16}$ - 18 x $1\frac{1}{4}$	12
	HNFL-516-18	Flange Whiz-Loc Nut, $\frac{5}{16}$ - 18	12
15	42-109	Outside Towel Mount	1
16	42-105	Top Strap	4
17	42-106	Bottom Strap	4
18	42-122	Rake Spring	12
19	42-129	Groomer Blades	3
20	42-107	Matting	4
21	15-013	Rubber Bumper	2
22	42-177	Spring Holder	12

42-130Q 84" (213CM) MILD STEEL TOURNAMENT RAKE DRAWING

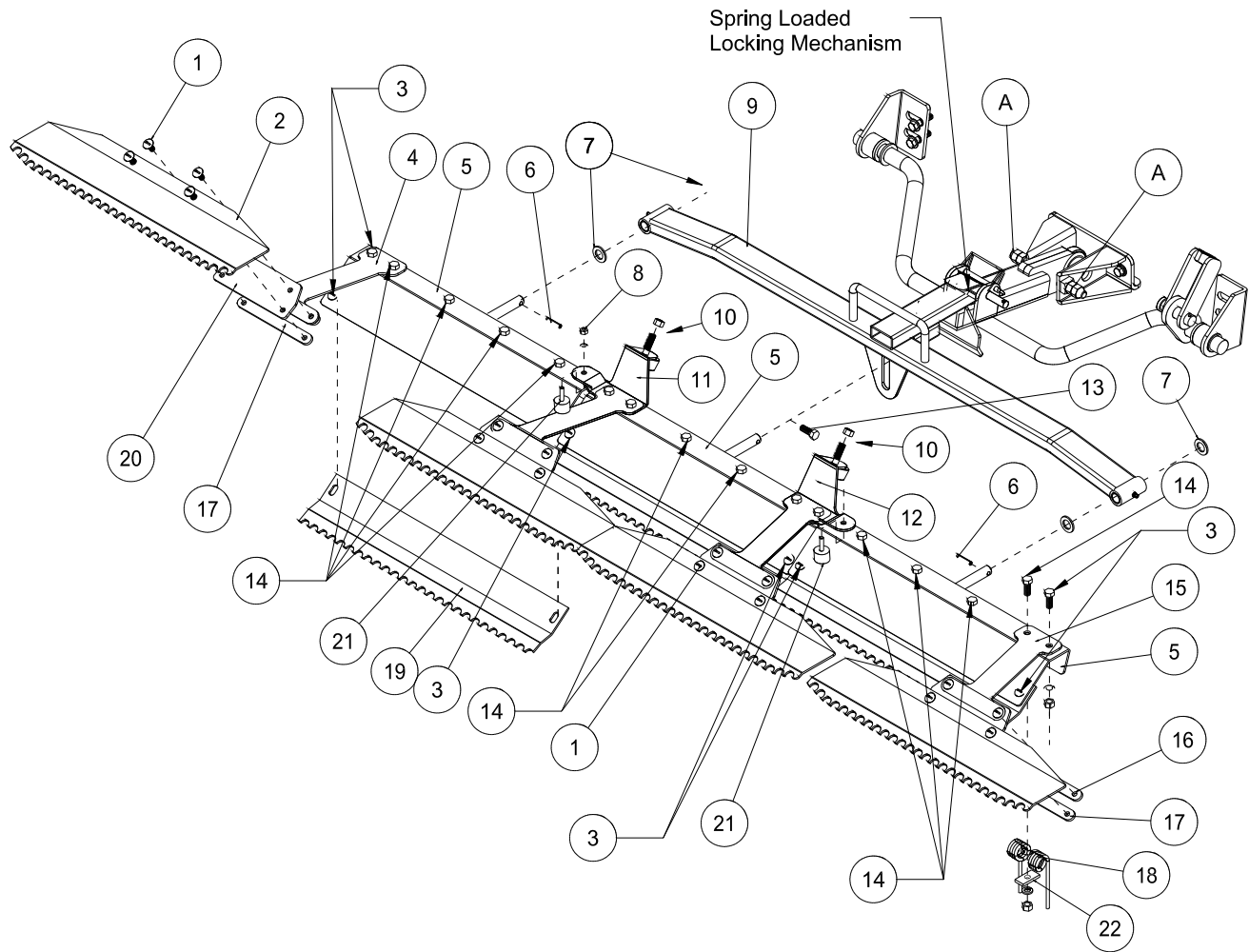

Rear Attachment

RAKE ASSEMBLY INSTRUCTIONS

1. Hex Bolt rake spring (Ref 18) to rake frames (Ref 5) using hardware (Ref 14). Leave the two outside holes on right, left, and center rake open.
 2. Attach rubber bumper (Ref 21) using cap nut and washer (Ref 8). Attach rubber grommet (Ref 10) to inside mounts (Ref 11 & 12)
 3. Attach the left outside mount (Ref 4), the left inside mount (Ref 11), the outside trowel mount (Ref 15), and the inside trowel mount (Ref 12) to the outside and center rakes (Ref 5) as shown. Use the $\frac{3}{4}$ " truss head screws (Ref 3) on the outside hole of each rake. Use the spring holder (Ref 22) and the $1\frac{1}{4}$ " truss head screws (Ref 14) to attach rake springs (Ref 18) to the rakes under the left outside and inside mounts and the outside and inside trowel mounts.
 4. Slide a machine bushing onto outside rake frames then slide the outside rake frames (Ref 5) into the tubing on the end of the drawbar. Hold in place with another machine bushing and a roll pin (Ref 6).
 5. Attach center rake (Ref 5) to draw bar (Ref 9) as shown, using $1\frac{3}{4}$ Hex Bolts and Nylon Lock Nuts (Ref 13) with the shaft of the center rake in the slot on the bottom of the drawbar.
 6. Attach the matting (Ref 20) and the top strap (Ref 16) to the inside and outside mounts using the truss head screw $\frac{5}{16}$ - 18 x 1 (Ref 1). Attach four finishing blades (Ref 2) to the matting on the inside and outside mounts with the truss head screw $\frac{5}{16}$ - 18 x 1 (Ref 1) going through the finishing blade, matting, and bottom strap (Ref 17).
 7. Place the three groomer blades (Ref 19) under the three rake assemblies as shown, using (Ref 3).
 8. Attach the rake lift to the trap rake quick hitch, by sliding the the hitch into the spring loaded locking mechanism.
 9. With the rake on the ground pull the rake to the right side until it is 2-3 inches from the tire.
 10. Using the adjustment Hex Bolts (Ref A) on the side of hitch, adjust the Hex Bolts until it hits the trap rake hitch. Lock jam nut so adjustment will not change.
 11. Repeat steps for the left side.
 12. Turn machine on and test for operation of rake assembly by raising and lowering the rake assembly. Also with rake down, turn sharp corners to check that rake does not touch wheels.
- NOTE:** Test rake in sand to assure tire tracks are covered by the rake when turning sharp corners in either direction. If there are tire tracks, readjust using the adjusting screws on the hitch, so the rake comes closer to the tire.

42-132Q 72" (183CM) MILD STEEL TOURNAMENT RAKE DRAWING

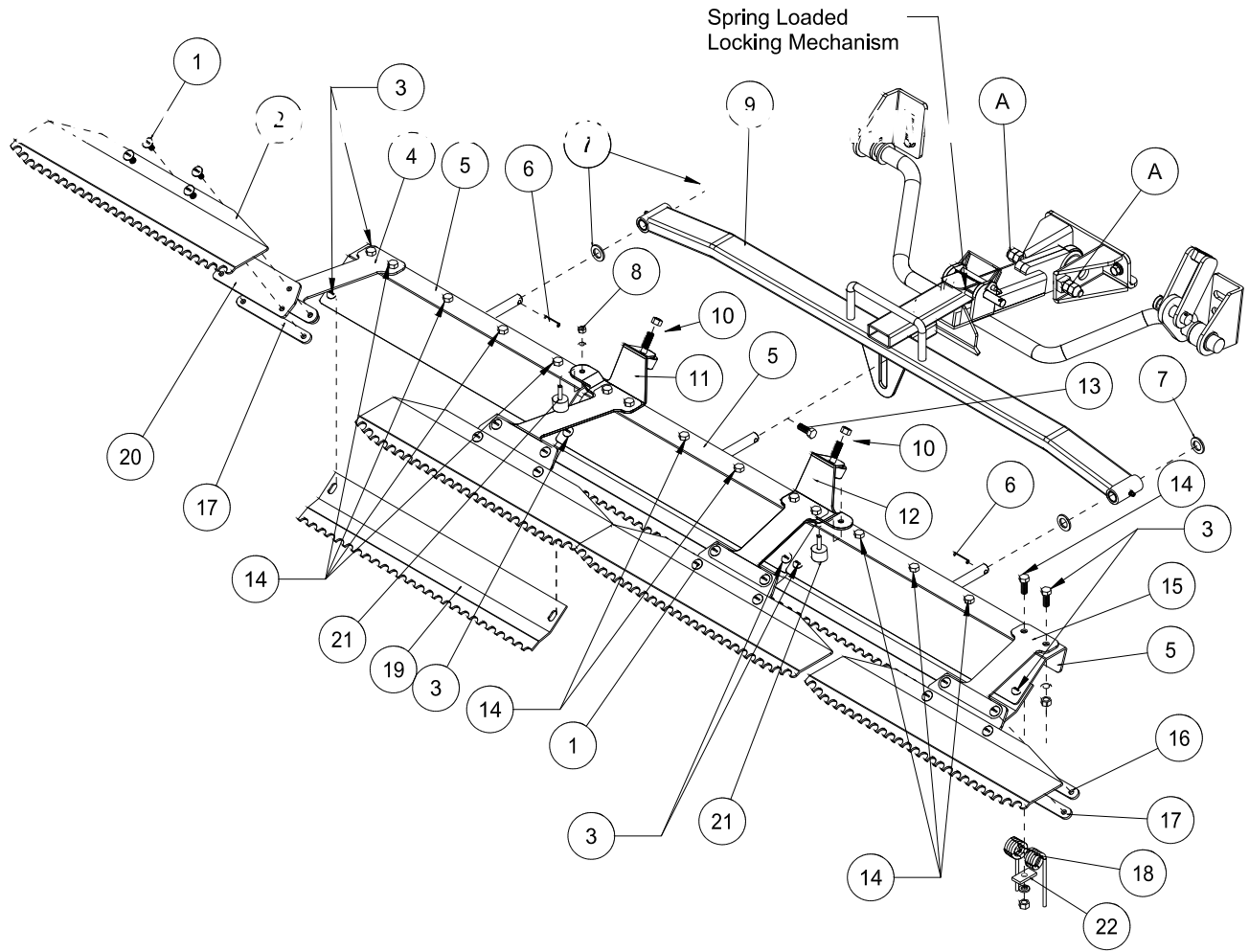

Rear Attachment

42-132Q 72"(183CM) MILD STEEL TOURNAMENT RAKE PARTS LIST

REF#	PART#	DESCRIPTION	QUANTITY
1	HSTP-516-18-100	Phillips Machine Screw, ⁵ / ₁₆ - 18 x 1	16
	HNFL-516-18	Flange Whiz-Loc Nut, ⁵ / ₁₆ - 18	16
2	42-170	Finishing Blades	4
3	HSTP-516-18-075	Phillips Machine Screw, ⁵ / ₁₆ - 18 x ³ / ₄	10
	HNFL-516-18	Flange Whiz-Loc Nut, ⁵ / ₁₆ - 18	10
4	42-111	Left Outside Mount	1
5	42-140	Outside Rake	3
6	HRP-14-100	Roll Pin, ¹ / ₄ x 1	2
7	HMB-58-14	Machine Bushing, ⁵ / ₈ x 14GA	4
8	HNC-14-20	Cap Nut, ¹ / ₄ - 20	2
	HWL-14	Lock Washer, ¹ / ₄	2
9	43-154	Draw Bar	1
	20-018	Oilite Bushing (comes with 43-154)	4
10	50-081	Rubber Bumper	2
	HNFL-38-16	Flange Whiz-Loc Nut, ³ / ₈ - 18	2
11	42-110	Left Inside Mount	1
12	42-108	Inside Trowel Mount	1
13	HB-14-20-175	Hex Bolt, ¹ / ₄ - 20 x 1 ³ / ₄	1
	HNTL-14-20	Nylon Lock Nut, ¹ / ₄ - 20	1
14	HSTP-516-18-125	Phillips Machine Screw, ⁵ / ₁₆ - 18 x 1 ¹ / ₄	12
	HNFL-516-18	Flange Whiz-Loc Nut, ⁵ / ₁₆ - 18	12
15	42-109	Outside Towel Mount	1
16	42-105	Top Strap	4
17	42-106	Bottom Strap	4
18	42-122	Rake Spring	12
19	42-171	Groomer Blades	3
20	42-107	Matting	4
21	15-013	Rubber Bumper	2
22	42-177	Spring Holder	12

42-132Q 72"(183CM) MILD STEEL TOURNAMENT RAKE DRAWING

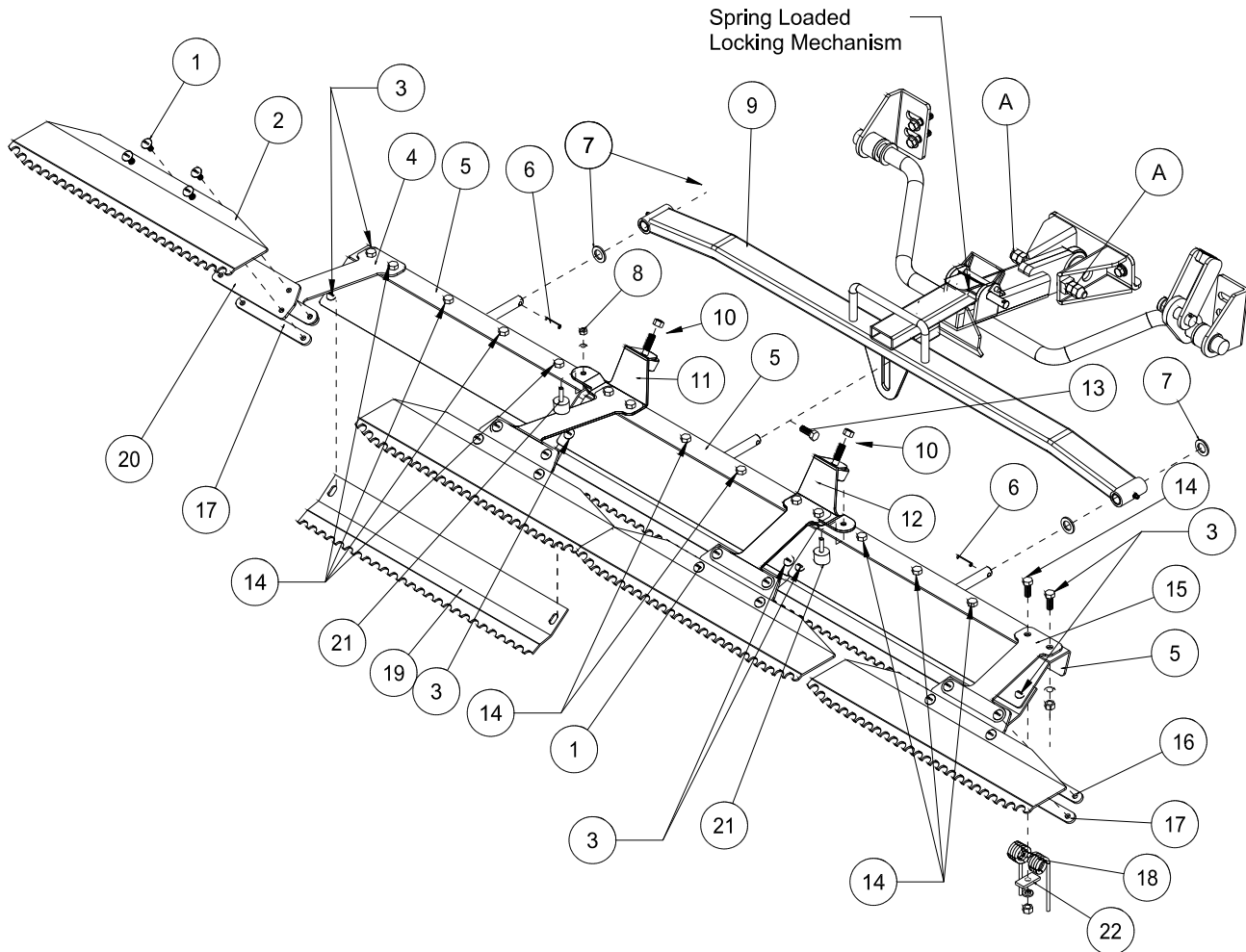

Rear Attachment

RAKE ASSEMBLY INSTRUCTIONS

1. Hex Bolt rake spring (Ref 18) to rake frames (Ref 5) using hardware (Ref 14). Leave the two outside holes on right, left, and center rake open.
 2. Attach rubber bumper (Ref 21) using cap nut and washer (Ref 8). Attach rubber grommets (Ref 10) to inside mounts (Ref 11 & 12)
 3. Attach the left outside mount (Ref 4), the left inside mount (Ref 11), the outside trowel mount (Ref 15), and the inside trowel mount (Ref 12) to the outside and center rakes (Ref 5) as shown. Use the $\frac{3}{4}$ " truss head screws (Ref 3) on the outside hole of each rake. Use the spring holder (Ref 22) and the $1\frac{1}{4}$ " truss head screws (Ref 14) to attach rake springs (Ref 18) to the rakes under the left outside and inside mounts and the outside and inside trowel mounts.
 4. Slide a machine bushing onto outside rake frames then slide the outside rake frames (Ref 5) into the tubing on the end of the drawbar. Hold in place with another machine bushing and a roll pin (Ref 6).
 5. Attach center rake (Ref 5) to draw bar (Ref 9) as shown, using $1\frac{3}{4}$ Hex Bolts and Nylon Lock Nuts (Ref 13) with the shaft of the center rake in the slot on the bottom of the drawbar.
 6. Attach the matting (Ref 20) and the top strap (Ref 16) to the inside and outside mounts using the truss head screw $\frac{5}{16}$ - 18 x 1 (Ref 1). Attach four finishing blades (Ref 2) to the matting on the inside and outside mounts with the truss head screw $\frac{5}{16}$ - 18 x 1 (Ref 1) going through the finishing blade, matting, and bottom strap (Ref 17).
 7. Place the three groomer blades (Ref 19) under the three rake assemblies as shown, using (Ref 3).
 8. Attach the rake lift to the trap rake quick hitch, by sliding the the hitch into the spring loaded locking mechanism.
 9. With the rake on the ground pull the rake to the right side until it is 2-3 inches from the tire.
 10. Using the adjustment Hex Bolts (Ref A) on the side of hitch, adjust the Hex Bolts until it hits the trap rake hitch. Lock jam nut so adjustment will not change.
 11. Repeat steps for the left side.
 12. Turn machine on and test for operation of rake assembly by raising and lowering the rake assembly. Also with rake down, turn sharp corners to check that rake does not touch wheels.
- NOTE:** Test rake in sand to assure tire tracks are covered by the rake when turning sharp corners in either direction. If there are tire tracks, readjust using the adjusting screws on the hitch, so the rake comes closer to the tire.

13-758 MAX FLEX SAND RAKE

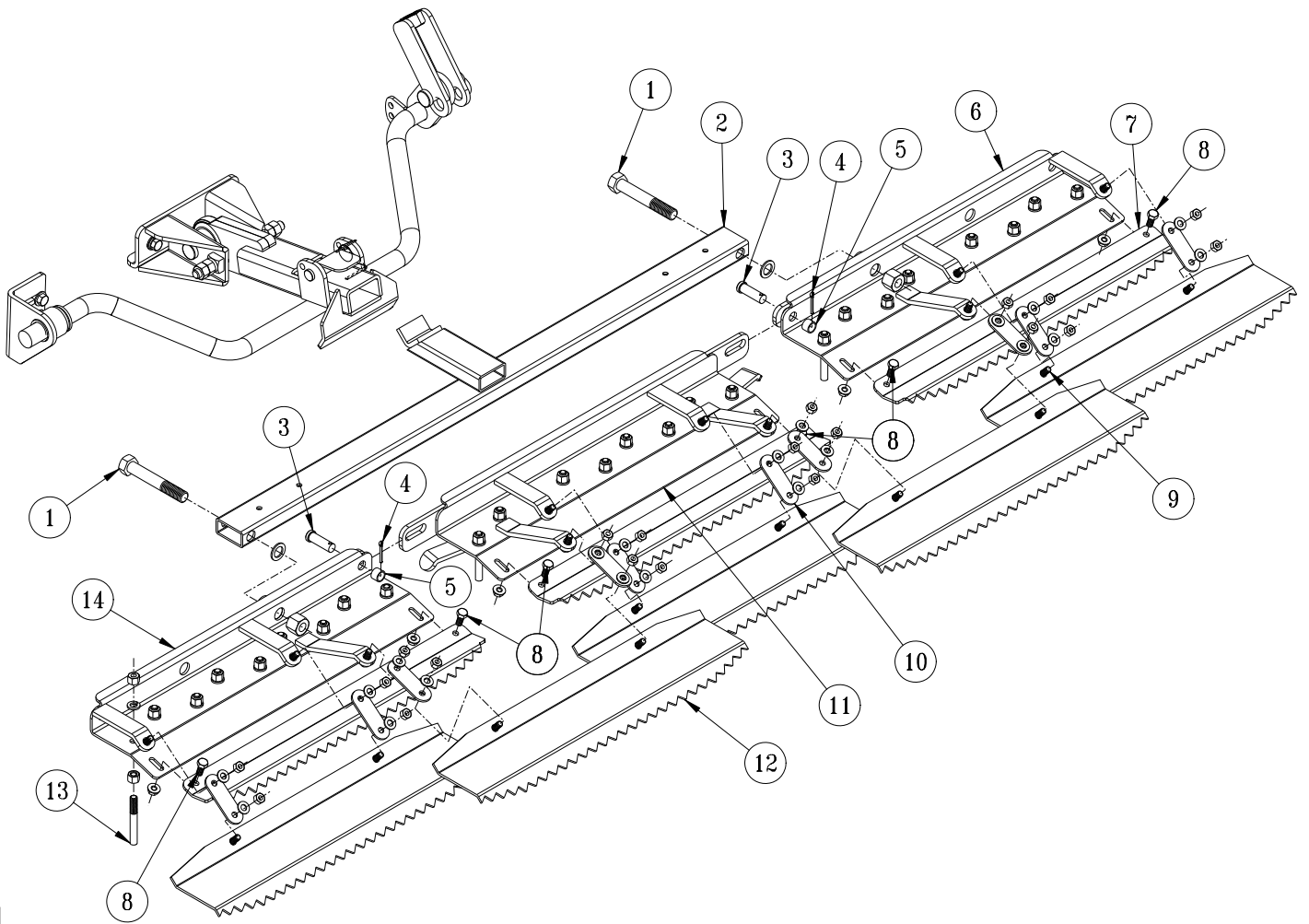

Rear Attachment

13-758 MAX FLEX SAND RAKE

REF#	PART#	DESCRIPTION	QUANTITY
1	HB-58-11-400	Hex Bolt, $\frac{5}{8}$ - 11 x 4	2
	HMB-58-14	Machine Bushing, $\frac{5}{8}$ x 14GA	2
	HNCL-58-11	Nylon Lock Nut, $\frac{5}{8}$ - 11	2
2	43-145	Draw bar	1
3	HCP-12-150	Clevis Pin, $\frac{1}{2}$ - $1\frac{1}{2}$	2
4	HP-18-100	Cotter Pin, $\frac{1}{8}$ x 1	2
5	76-275	Spacer	2
6	13-762	Right Rake	1
7	13-759	Grooming Blade	3
8	HB-516-18-075	Hex Bolt, $\frac{5}{16}$ - 18 x $\frac{3}{4}$	6
	HNFL-516-18	Flange Whiz-Loc Nut, $\frac{5}{16}$ - 18	6
9	HBFL-516-18-100	Flange Lock Hex Bolt, $\frac{5}{16}$ - 18 x 1	20
	HNTL-516-18	Nylon Lock Nut, $\frac{5}{16}$ - 18	20
	HW-516	Flat Washer, $\frac{5}{16}$	20
10	13-757	Rake Connect Strap	10
11	13-761	QH Center Rake	1
12	13-443	Finishing Blade	5
14	13-763	Left Rake	1
13*	13-445	Rake Teeth Kit (27 Studs and Hardware)	1

INSTALLATION INSTRUCTIONS

1. Hex Bolt rake teeth (Ref 13) to frames, keeping all the same length.
2. Lay out rake frames (Refs 6, 11 & 14). Connect them using Clevis Pin (Ref 3), Spacer (Ref 5) and Cotter Pin (Ref 4).
3. Attach Left Frame (Ref 14) and Right Frame (Ref 6) to Draw bar (Ref 2) using $\frac{5}{8}$ Hex Bolt, Machine Bushing, and Center Nylon Lock Nut (Ref 1).
4. Attach the three Groomer Blades (Ref 7), one to each of the Rake Frames (Refs 6, 11 & 14) using two Hex Bolts and Flange Whiz-Loc Nuts (Ref 8). Slide Groomer Blades to end of slot and tighten hardware.
5. Attach the five Finishing Blades (Ref 12) to the tabs of the rake frames using two Rake Connect Strap (Ref 10) per Finishing blade. Secure using Flange Lock Hex Bolt, Flat Washer and Nylon Lock Nut (Ref 9).

NOTE: Attach Straps using hardware as illustrated, placing Flat Washer on Strap then secure with Nylon Lock Nut. Attaching with the Flange Hex Bolt in contact with the Strap will cause the Strap to bind and misalign Finishing Blade.

6. Attach the rake to the trap rake quick hitch by sliding the draw bar hitch into the spring loaded locking mechanism.
7. With the rake on the ground pull the rake to the right side until it is 2-3 inches from the tire.
8. Repeat steps on left side.
9. Turn machine on and test for operation of rake assembly by raising and lowering the rake assembly. Also with rake down, turn sharp corners to check that rake does not touch wheels.
10. **NOTE:** Test rake in sand to assure tire tracks are covered by the rake when turning sharp corners in either direction. If there are tire tracks, readjust using the adjusting screws on the hitch, so the rake comes closer to the tire.

45-503 84" RAKE ASSEMBLY DRAWING

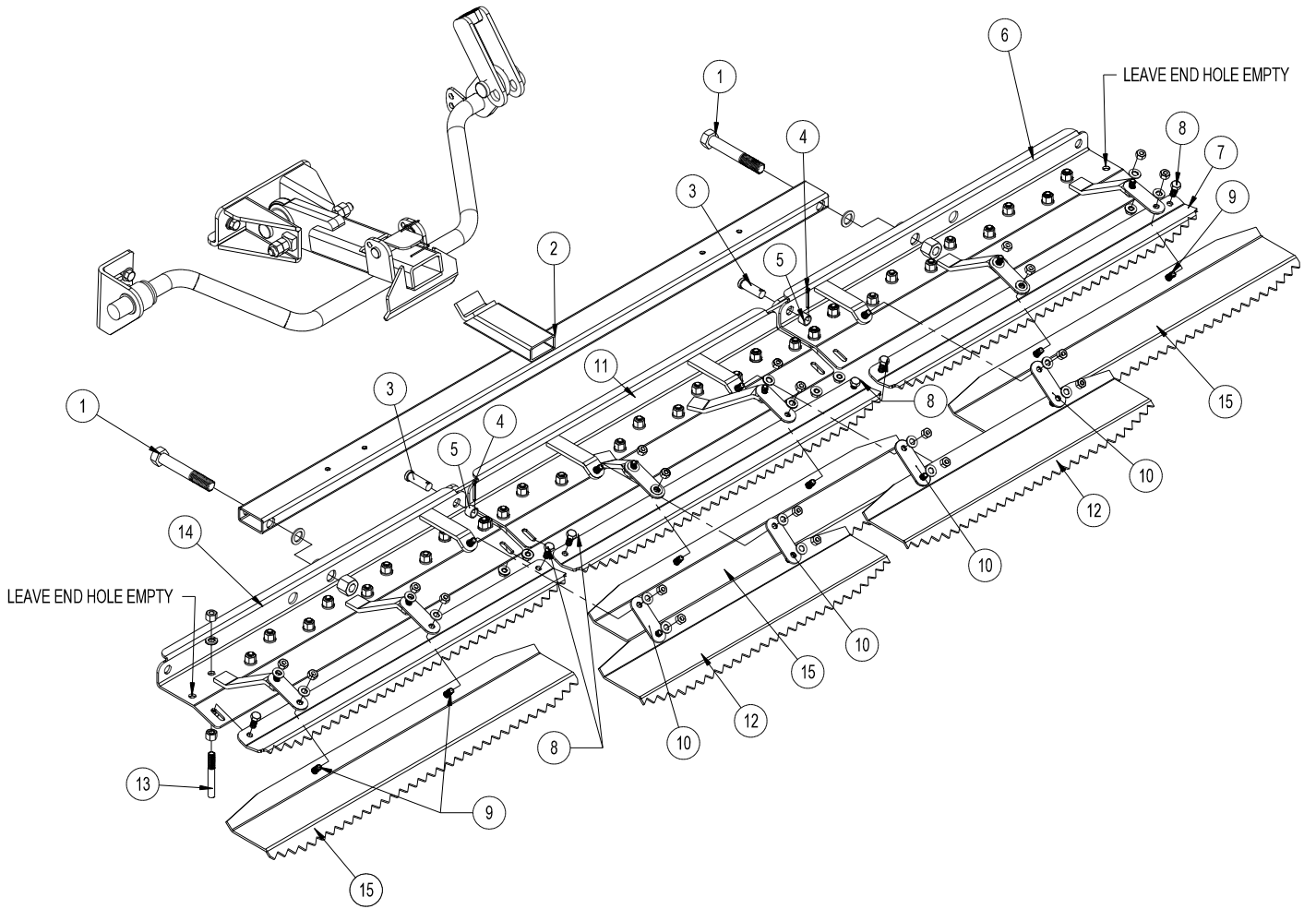

Rear Attachment

45-503 84" RAKE ASSEMBLY PARTS LIST

REF#	PART#	DESCRIPTION	QUANTITY
1*	HB-58-11-400	Hex Bolt, $\frac{5}{8}$ - 11 x 4	2
	HMB-58-14	Machine Bushing, $\frac{5}{8}$ x 14GA	2
	HNCL-58-11	Nylon Lock Nut, $\frac{5}{8}$ - 11	2
2	45-588	Draw bar	1
3*	HCP-12-150	Clevis Pin, $\frac{1}{2}$ - $1\frac{1}{2}$	2
4*	HP-18-100	Cotter Pin, $\frac{1}{8}$ x 1	2
5	76-275	Spacer	2
6	45-590	Right Rake Frame	1
7	45-586	Grooming Blade	3
8*	HB-516-18-075	Hex Bolt, $\frac{5}{16}$ - 18 x $\frac{3}{4}$	6
	HNFL-516-18	Flange Whiz-Loc Nut, $\frac{5}{16}$ - 18	6
9*	HBFL-516-18-075	Flange Whiz-Loc Bolt, $\frac{5}{16}$ - 18 x $\frac{3}{4}$	20
	HNTL-516-18	Nylon Lock Nut, $\frac{5}{16}$ - 18	20
	HW-516	Flat Washer, $\frac{5}{16}$	20
10	13-757	Rake Connect Strap	10
11	45-589	Center Rake Frame	1
12	13-443	Finishing Blade	2
13	19-106	Rake Teeth	31
	HN-38-16	Hex Nut, $\frac{3}{8}$ -16	62
	HWL-38	Lock Washer, $\frac{3}{8}$	31
14	45-591	Left Rake Frame	1
15	45-587	Finishing Blades	3
*	13-764	Hardware Kit	1

INSTALLATION INSTRUCTIONS

- Hex Bolt rake teeth (Ref 13) to frames, keeping all the same length.
- Lay out rake frames (Refs 6, 11 & 14). Connect them using clevis pin (Ref 3), Spacer (Ref 5) and cotter pin (Ref 4).
- Attach left frame (Ref 14) and right frame (Ref 6) to draw bar (Ref 2) using $\frac{5}{8}$ Hex Bolt, machine bushing, and center Nylon Lock Nut (Ref 1).
- Attach the three groomer blades (Ref 7), one to each of the rake frames (Refs 6, 11 & 14) using two Hex Bolts and Flange Whiz-Loc Nuts (Ref 8). Slide groomer blades to end of slot and tighten hardware.
- Attach three large finishing blades (Ref 15) and then the two smaller finishing blades (Ref 12) to the tabs of the rake frames using two rake connect strap (Ref 10) per finishing blade. Secure, using flange lock Hex Bolt, flat washer and Nylon Lock Nut (Ref 9).

NOTE: Attach Straps using hardware as illustrated, placing Flat Washer on Strap then secure with Nylon Lock Nut. Attaching with the Flange Hex Bolt in contact with the Strap will cause the Strap to bind and misalign Finishing Blade.

- Attach the rake to the trap rake quick hitch by sliding the draw bar hitch into the spring loaded locking mechanism.
- With the rake on the ground pull the rake to the right side until it is 2-3 inches from the tire.
- Repeat steps on left side.
- Turn machine on and test for operation of rake assembly by raising and lowering the rake assembly. Also with rake down, turn sharp corners to check that rake does not touch wheels.
- NOTE:** Test rake in sand to assure tire tracks are covered by the rake when turning sharp corners in either direction. If there are tire tracks, readjust using the adjusting screws on the hitch, so the rake comes closer to the tire.

45-511 RUBBER FLEX RAKE ASSEMBLY DRAWING

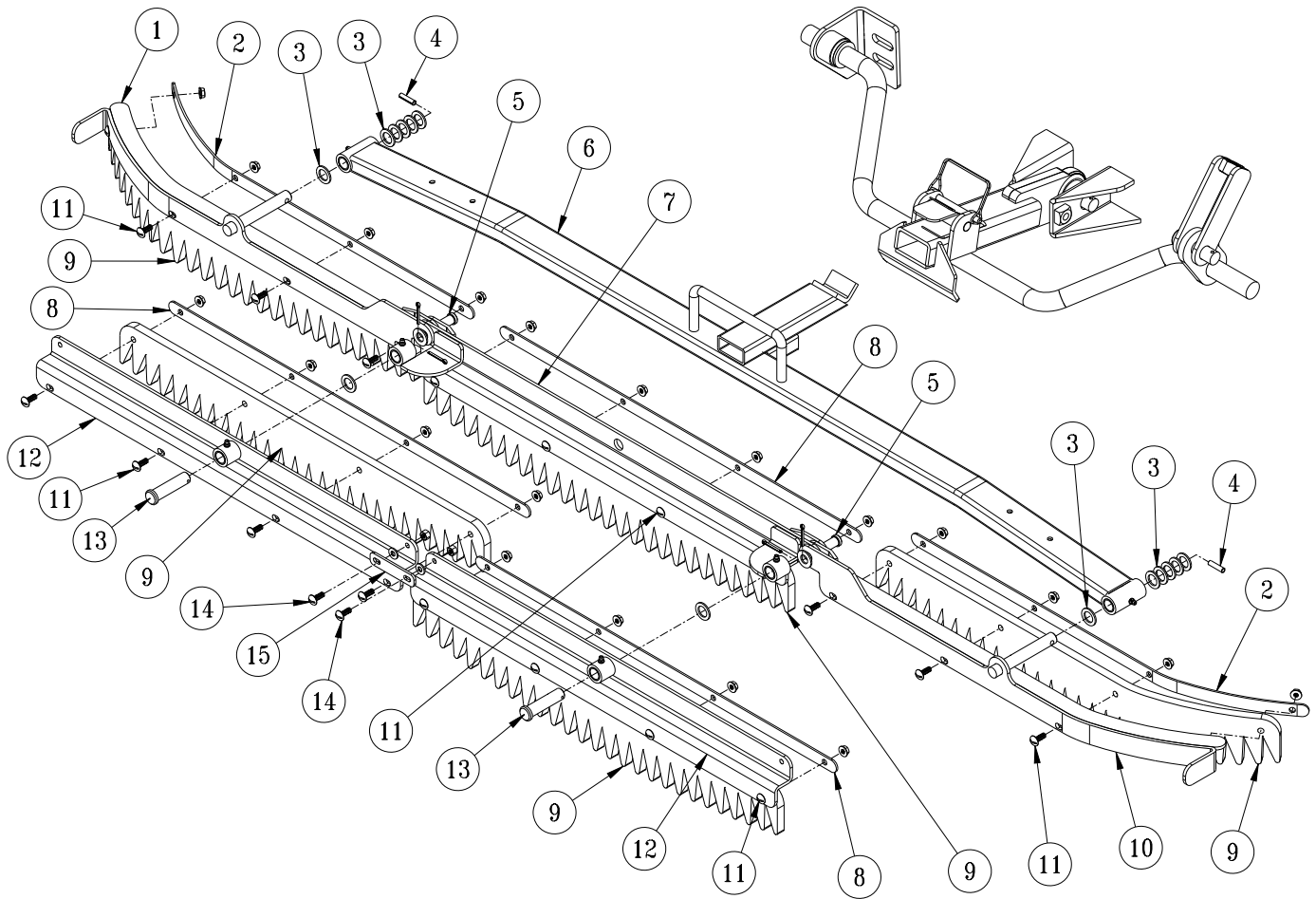

Rear Attachment

45-511 RUBBER FLEX RAKE ASSEMBLY PARTS LIST

REF#	PART#	DESCRIPTION	QUANTITY
1	45-653	LH Wing	1
2	45-657	Curved Cover Strap	2
3	HMB-58-14	Machine Bushing, $\frac{5}{8}$ x 14GA	12
4	HRP-14-100	Roll Pin, $\frac{1}{4}$ x 1	2
5	HCP-12-150	Clevis Pin, $\frac{1}{2}$ - $1\frac{1}{2}$	2
	HMB-12-14	Machine Bushing, $\frac{1}{2}$ x 14GA	2
	HP-18-100	Cotter Pin, $\frac{1}{8}$ x 1	2
6	45-649	Draw bar	1
7	45-654	Center Rake	1
8	45-658	Flat Cover Strap	1
9	45-651	Rubber Rake Blade	5
10	45-652	RH Wing	1
11	HSTP-14-20-100	Phillips Machine Screw, $\frac{1}{4}$ - 20 x 1	20
	HNFL-14-20	Flange Whiz-Loc Nut, $\frac{1}{4}$ - 20	20
12	45-655	Rear Rake Mount	2
13	HCP-58-250	Clevis Pin, $\frac{5}{8}$ x $2\frac{1}{2}$	2
	HMB-58-14	Machine Bushing, $\frac{5}{8}$ x 14GA	2
	HP-18-100	Cotter Pin, $\frac{1}{8}$ x 1	2
14	HSTP-14-20-075	Phillips Machine Screw, $\frac{1}{4}$ - 20 x $\frac{3}{4}$	2
	HNTL-14-20	Nylon Lock Nut, $\frac{1}{4}$ - 20	2
	HW-14	Flat Washer, $\frac{1}{4}$	2
15	45-656	Rake Strap	1

INSTALLATION INSTRUCTIONS

- Hex Bolt rubber rake blades (Ref 9) onto all five rake sections using $\frac{1}{4}$ x 1 machine Hex Bolts, and Flange Whiz-Loc Nuts (Ref 11). Add cover straps (Ref 8) and then tighten hardware.
- Lay out right, left and center rake sections and connect them using $\frac{1}{2}$ x $1\frac{1}{2}$ clevis pins, machine bushings, and cotter pins (Ref 5).
- Attach the three assembled sections onto the draw bar (Ref 6) and secure with machine bushings and roll pins (Ref 3 and 4).
- Connect the two rear rake mounts (Ref 12) together with the rake strap (Ref 8) using two $\frac{1}{4}$ x $\frac{3}{4}$ machine Hex Bolts with Nylon Lock Nuts (Ref 14). **Only tighten enough so they move freely.**
- Connect the two assembled rear rake mounts onto the other rake sections using two $\frac{5}{8}$ x $2\frac{1}{2}$ clevis pins, machine bushings and cotter pins (Ref 13).
- Attach the rake to the bunker rake quick hitch by sliding the draw bar into the spring loaded locking mechanism.
- With the rake on the ground, pull the rake to the sides and adjust hitch stops so the rake stops about 2" from the tires.
- Start machine and test for operation of rake assembly by raising and lowering the rake assembly. Check for loose hardware.

13-740 SAND RAKE BRUSH KIT DRAWING

For use with 42-130 and 45-511

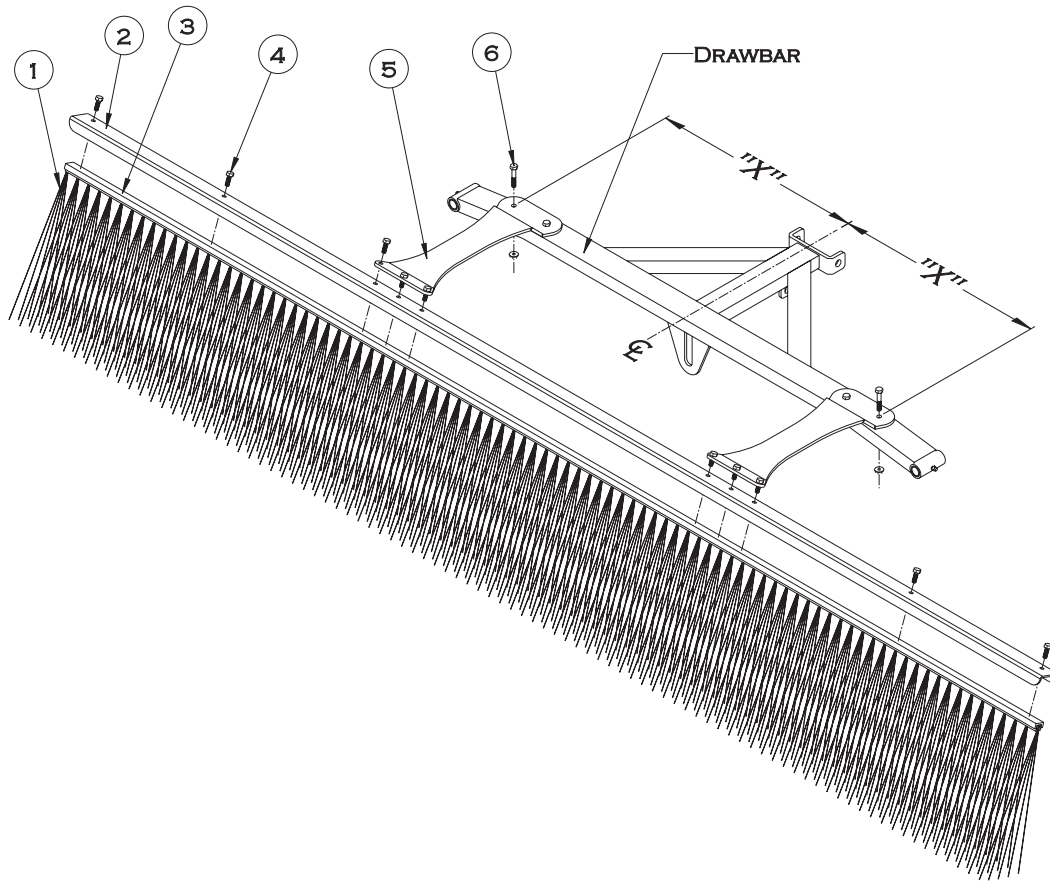

REF#	PART#	DESCRIPTION	QUANTITY
1	13-738	Brush, 89 x 11	1
2	13-737	Brush Channel	1
3	13-739	Brush Track	1
4	HB-14-20-075	Hex Bolt, 1/4 - 20 x 3/4	10
	HNFL-14-20	Flange Whiz-Loc Nut, 1/4 - 20	10
5	13-681	Mounting Brackets	2
6	HB-14-20-150	Hex Bolt, 1/4 - 20 x 1 1/2	4
	HNFL-14-20	Flange Whiz-Loc Nuts, 1/4 - 20	4

INSTALLATION INSTRUCTIONS

- Place the Brush (Ref 1) into the Brush Track (Ref 3). Place the Brush Channel (Ref 2) between the brush track and the mounting brackets. Now Hex Bolt the Mounting Brackets (Ref 5) to the brush track using the 3/4" Hex Bolts and flange whiz-Nylon Lock Nuts(Ref 4).
- To mount the Brush Assembly (Refs 1-5) to the Rake Draw bar, first align the Mounting Brackets so the Brush Assembly is centered ("X" measurements are equal) on the Rake Draw bar. Mark the locations for the four holes that will need to be drilled. *Note: To fit the curve of the Rake Draw bar, a small amount of twist will need to be put in the Mounting Brackets. This can be done by clamping the Mounting Brackets to the Draw bar.*
- Mount the Brush Assembly to the Draw bar using the four 1 1/2" Hex Bolts and flange whiz-Nylon Lock Nuts(Ref 6).

13-684 SAND RAKE BRUSH KIT DRAWING

For use with 13-438

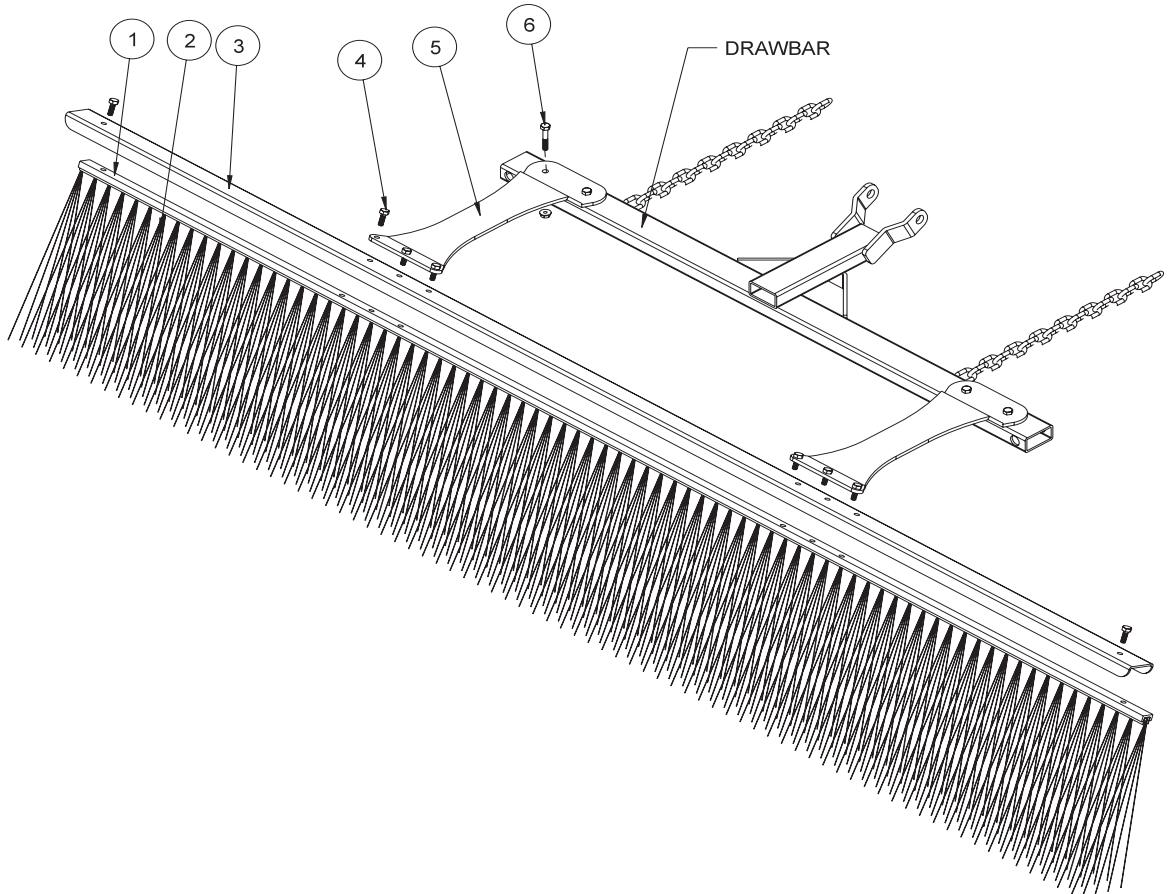

REF#	PART#	DESCRIPTION	QUANTITY
1	13-683	Brush Track	1
2	13-682	Brush 77 x 11	1
3	13-688	Brush Channel	1
4	HB-14-20-075	Hex Bolt, 1/4 - 20 x 3/4	8
	HNFL-14-20	Flange Whiz-Loc Nut, 1/4 - 20	8
5	13-681	Mounting Brackets	2
6	HB-14-20-150	Hex Bolt, 1/4 - 20 x 1 1/2	4
	HNFL-14-20	Flange Whiz-Loc Nut, 1/4 - 20	4

INSTALLATION INSTRUCTIONS

- Place the brush (Ref 2) into the brush track (Ref 1). Place the brush channel (Ref 3) between the brush track and the mounting brackets. Now Hex Bolt the mounting brackets (Ref 5) to the brush track using the 3/4" Hex Bolts and flange whiz-Nylon Lock Nuts (Ref 3).
- Mount the brush assembly to the draw bar using four 3/4" Hex Bolts and flange whiz-Nylon Lock Nuts (Ref 5).

Rear Attachment

13-298Q FAN RAKE ATTACHMENT DRAWING

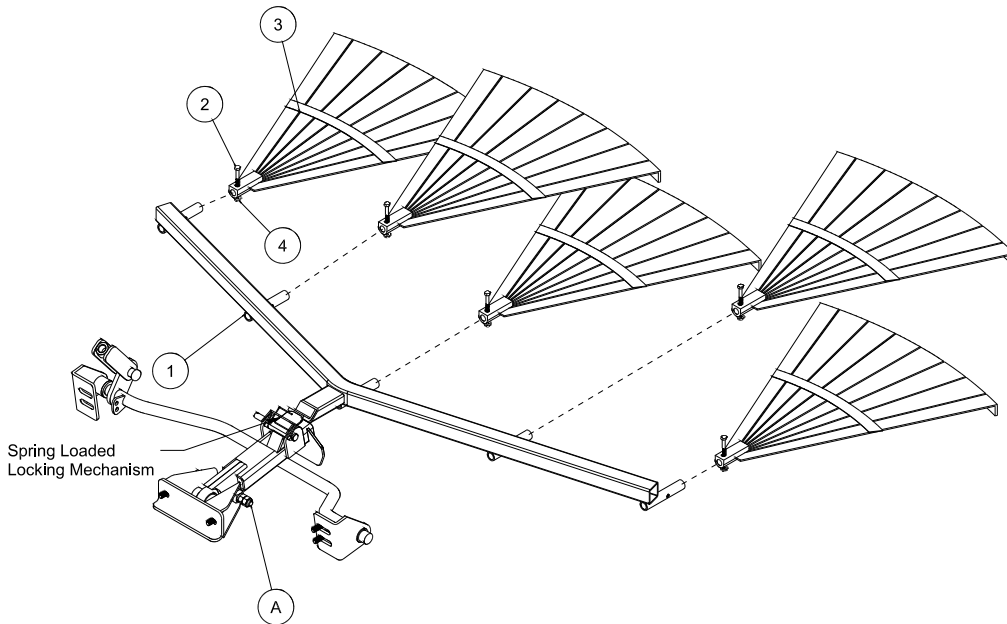

REF#	PART#	DESCRIPTION	QUANTITY
1	43-153	Frame	1
2	HB-14-20-200	Hex Bolt, 1/4 - 20 x 2	5
3	13-310	Rake	5
4	HNCL-14-20	Center Nylon Lock Nut, 1/4 - 20	5

INSTALLATION INSTRUCTIONS

1. Assemble the five rakes (Ref 3) to the frame using the Hex Bolt and center Nylon Lock Nuts (Ref 2 and 4). Slide the fan rake assembly under the rear of the trap rake to the hitch.
2. Attach the rake lift to the trap rake quick hitch, by sliding the hitch into the spring loaded locking mechanism.
3. With the rake on the ground pull the rake to the right side until it is 2-3 inches from the tire.
4. Repeat steps on left side.
5. Turn machine on and test for operation of rake assembly by raising and lowering the rake assembly. Also with rake down, turn sharp corners to check that rake does not touch wheels.

13-319-K FAN RAKE KIT DRAWING

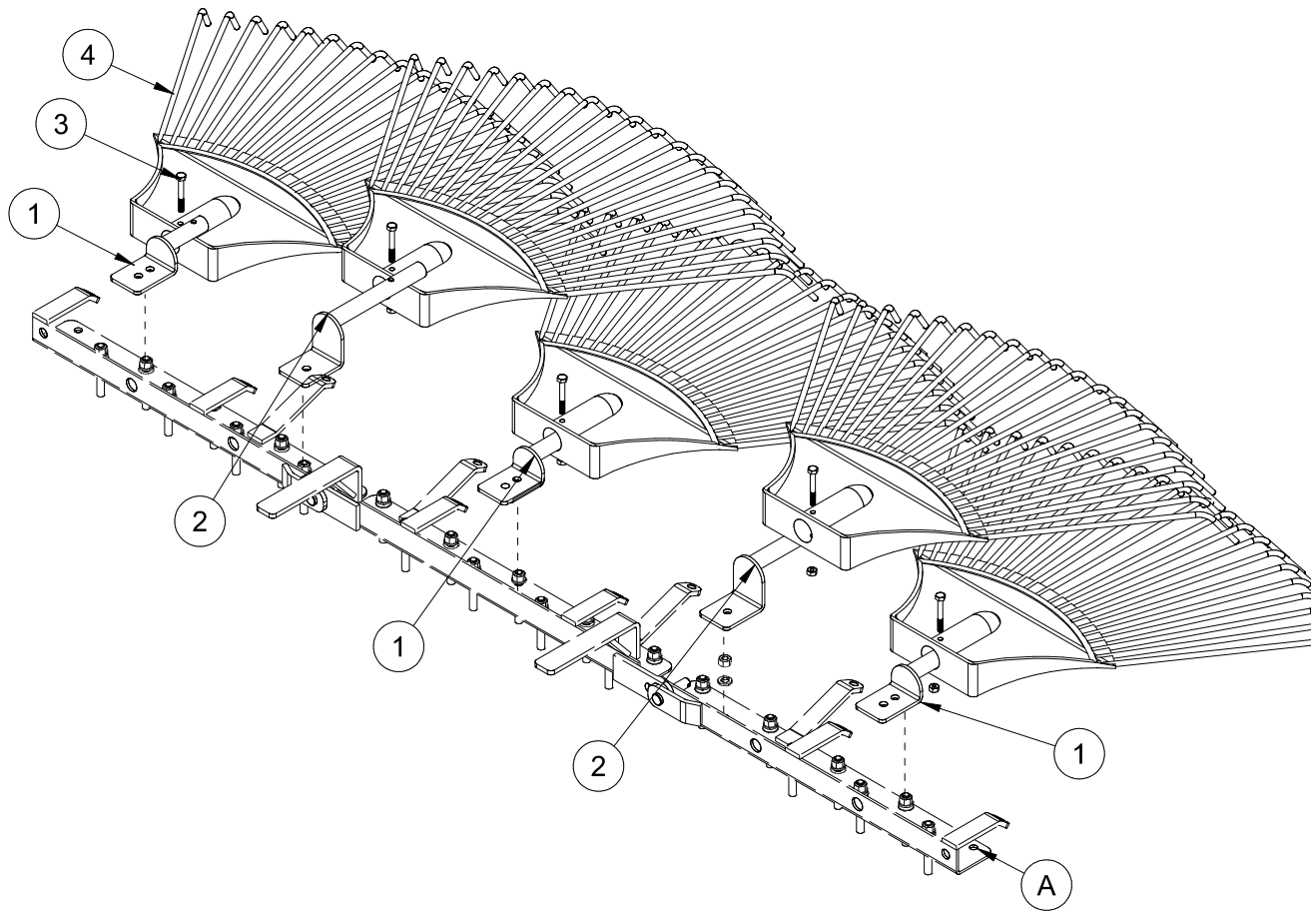

REF#	PART#	DESCRIPTION	QUANTITY
1	13-327	Holder, Universal	3
2	13-329	Long Holder	2
3	HB-14-20-200	Hex Bolt, 1/4 - 20 x 2	5
	HNTL-14-20	Nylon Lock Nut, 1/4 - 20	5
4	13-310	Fan Rake	5
A	No studs in first slot - Leave Empty.		

FAN RAKE KIT INSTRUCTIONS

1. Assemble the fan rakes (Ref 4) to the frame using the bolt, and lock nuts(Ref 3). Slide the fan rake assembly under the rear of the trap rake to the hitch.
2. Attach the fan rake assemblies to the top of the frame. Use the nuts and washers that are on the studs to secure in place. The outside assemblies go in the third hole from the end.
3. Turn machine on and test for operation of rake assembly by raising and lowering the rake assembly. Also, with rake down, turn sharp corners to check that rake does not touch the wheels.

Rear Attachment

26-007Q PROFESSIONAL INFIELD FINISHER DRAWING

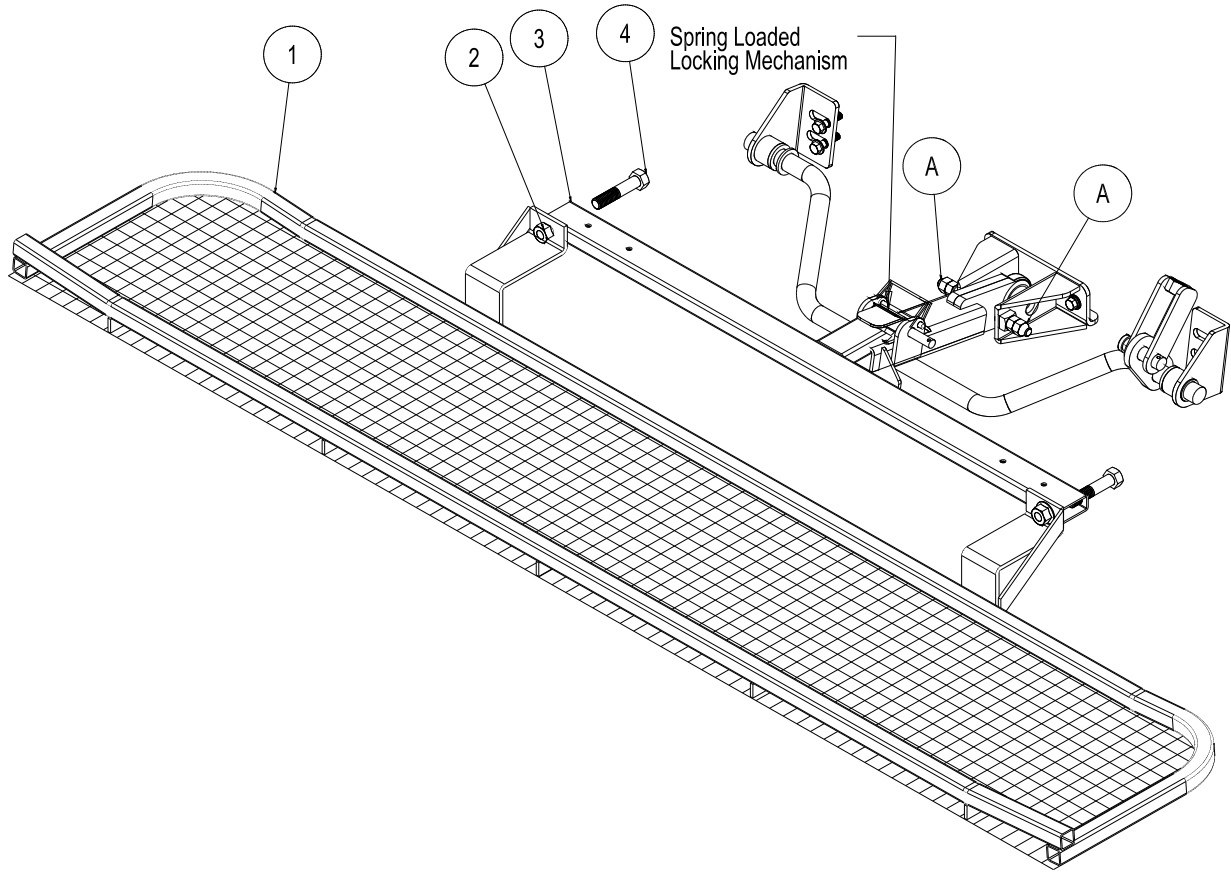

Rear Attachment

26-007Q PROFESSIONAL INFIELD FINISHER PARTS LIST

REF#	PART#	DESCRIPTION	QUANTITY
1	26-045	Leveling Screen	1
2	HNCL-58-11	Center Nylon Lock Nut, $\frac{5}{8}$ - 11	2
3	43-145	Draw bar	1
4	HB-58-11-300	Hex Bolt, $\frac{5}{8}$ - 11 x 3	2

INSTALLATION INSTRUCTIONS

The Professional Field Finisher is used for smoothing and leveling fields to professional standards.

1. Attach leveling screen (Ref 1) to draw bar (Ref 3) using two Hex Bolts (Ref 4) and center Nylon Lock Nuts (Ref 2).
2. Mount Professional Field Finisher to the hitch on the trap rake by sliding the draw bar into the quick hitch locking mechanism.
3. When Professional Field Finisher is attached, adjust Hex Bolts on hitch (Ref A) to hold Finisher in desired position.
4. **NOTE:** When assembled properly, rake will angle down from front to back. If front of finisher is not higher than the back, damage will result to infield.
5. When removing the attachment from machine. Push down on quick hitch locking mechanism and pull accessory out.

43-002Q FLEX ACTION FIELD FINISHER WITH BRUSH DRAWING

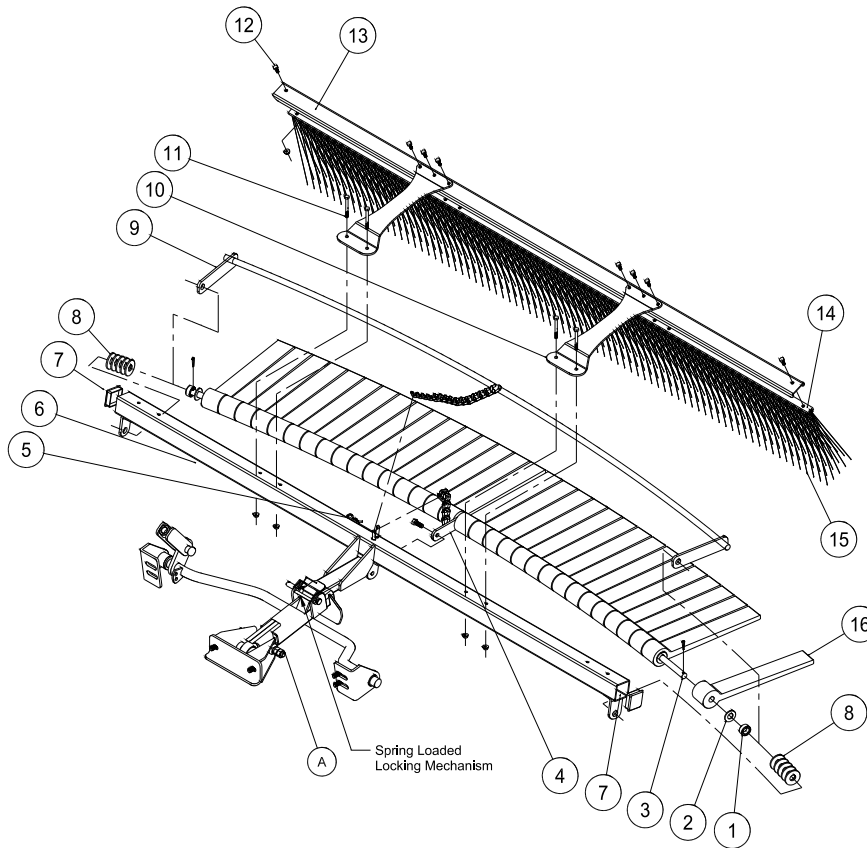

REF#	PART#	DESCRIPTION	QUANTITY
1	11-040	Spacer, $\frac{3}{4}$ "	2
2	HW-58	Washer, $\frac{5}{8}$	32
3	26-049	Mounting Bar	1
	HP-18-100	Cotter Pin, $\frac{1}{8}$ x 1	2
4	26-048	Flail Bar Strap	1
	HB-38-16-100	Hex Bolt $\frac{3}{8}$ -16 x 1	1
	HNCL-38-16	Center Nylon Lock Nut $\frac{3}{8}$ -16	1
5	HHP-18	Bridge Pin, $\frac{1}{8}$	2
6	43-146	Frame	1
7	18-297	Cap Plug	2
8	HMB-58-14	Machine Bushing $\frac{5}{8}$ x 14GA	10
9	26-047	Leveler Bar	1
10	13-681	Mount Bracket	2
11	HB-14-20-250	Hex Bolt, $\frac{1}{4}$ -20 x $2\frac{1}{2}$	4
	HNFL-14-20	Flange Whiz-Nylon Lock Nut, $\frac{1}{4}$ -20	4
12	HB-14-20-075	Hex Bolt, $\frac{1}{4}$ -20 x $\frac{3}{4}$	8
	HNFL-14-20	Flange Whiz-Nylon Lock Nut, $\frac{1}{4}$ -20	8
13	13-688	Brush Channel	1
14	13-683	Brush Track	1
15	13-682	Brush, 77 x 11	1
16	26-041	Rasp Flail	32

Rear Attachment

43-002Q FLEX ACTION FIELD FINISHER WITH BRUSH INSTRUCTIONS

ASSEMBLY INSTRUCTIONS

1. Install flail bar strap (Ref 4) to center of mounting bar (Ref 3) with chain on top of flail bar strap and mounting bar bent away from you. Apply a light coat of lubricant to overall length of mounting bar.
2. Install one rasp flail (Ref 17) with knobby side down adjacent to sides of flail bar strap. Now install a flat washer (Ref 2) so it sits adjacent with the outside of the rasp flail. Continue to install flails with knobby sides down with washers between until you have **16** flails and washers on the **left hand side** of bar strap and **17** flails and washers on the **right hand side**. Force all flails tightly toward bar strap.
3. After all 33 flails have been installed, place one spacer (Ref 1) to each end of mounting bar adjacent to washer.
4. Install leveler bar (Ref 10) to mounting bar, with curved leveler bar resting on top on the smooth sides of flails. **If all flails and washers do not fit snugly at this time, remove leveler bar and install enough machine bushings next to spacer to ensure a snug fit.** Then reinstall leveler bar.
5. Lay the frame (Ref 7) on the floor or bench with welded tabs facing up. Install ends of assembled mounting bar, with knobby sides of flails up, into welded tabs on each end of frame and secure with $\frac{1}{8}$ x 1 cotter pin.
6. Install flail bar strap (Ref 4) to center tab on frame with $\frac{3}{8}$ -16 x $1\frac{1}{2}$ Hex Bolt and $\frac{3}{8}$ -16 center Nylon Lock Nut. Loose fit is required. Do not over tighten.
7. Flip assembly over so knobby sides of flails are now facing down. Connect Finisher to the Quick Hitch frame, locking securely in the locking mechanism, as illustrated.
8. Install bar strap chain over welded pin on frame. Install leveler bar chain on to pin and secure in place with bridge pin. Use last bridge pin and clevis pin to hitch field finisher to your machine.

OPERATING INSTRUCTIONS

Running attachment with all flails down, flat on the surface, will provide a leveling function. Running attachment partially raised and flails at a 20° - 40° angle in relation to the level surface, will provide a finishing function. The flails increase down pressure for desired finish. Drive in wide circular patterns and increase or decrease ground speed to achieve desired finish.

BRUSH ASSEMBLY

1. Place the brush (Ref 16) into the brush track (Ref 15). Place the brush channel (Ref 14) between the brush track and the mounting brackets. Now Hex Bolt the mounting brackets (Ref 11) to the brush track using the $\frac{1}{4}$ - 20 x $\frac{3}{4}$ Hex Bolts and $\frac{1}{4}$ - 20 flange whiz-loc Nuts (Ref 13).
2. Mount the brush assembly to the frame using the (4) $\frac{1}{4}$ -20 x $2\frac{1}{2}$ Hex Bolts and $\frac{1}{4}$ - 20 flange whiz-loc Nuts (Ref 12).

26-008Q FLEX ACTION FIELD FINISHER DRAWING

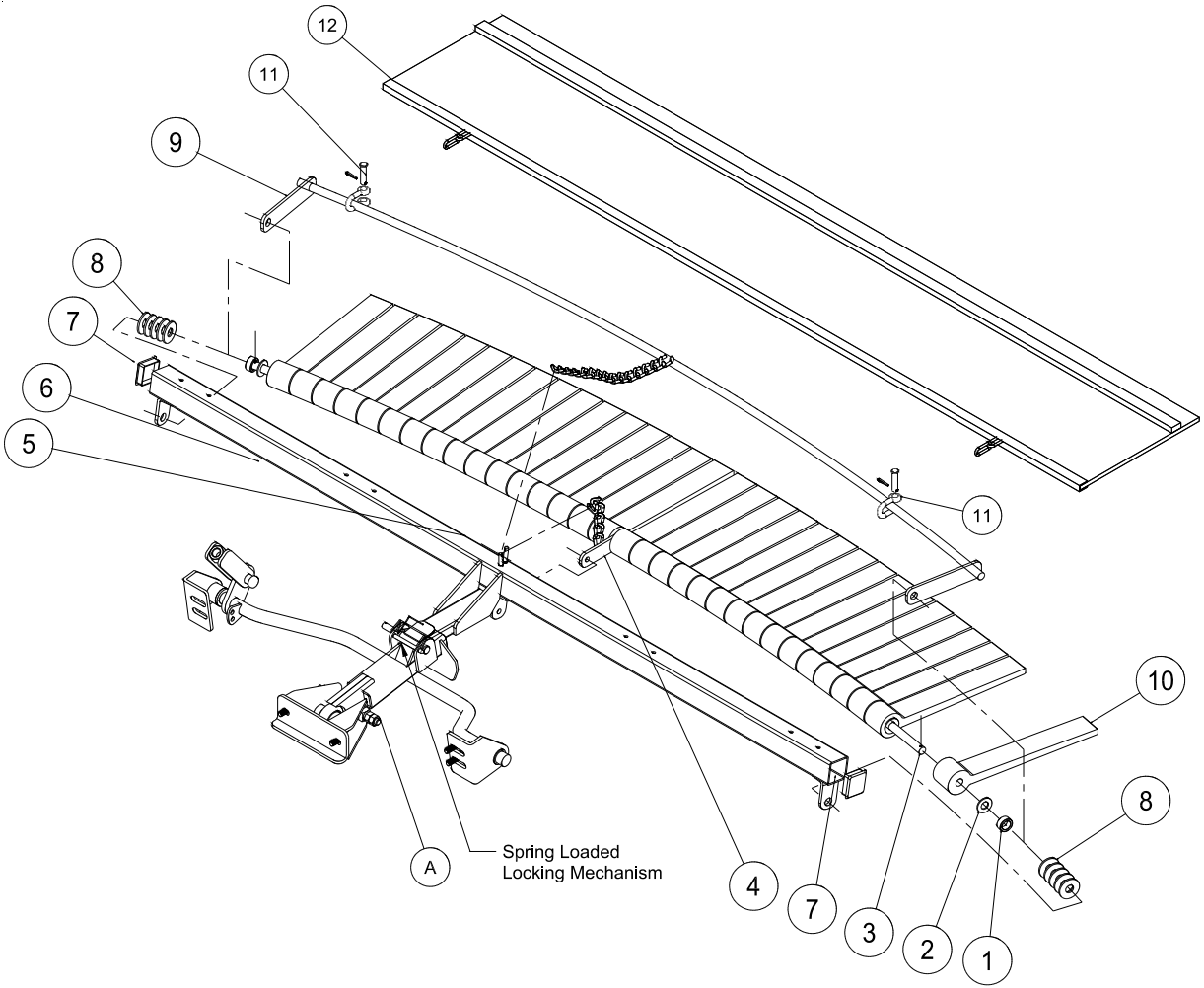

Rear Attachment

26-008Q FLEX ACTION FIELD FINISHER PARTS LIST

REF#	PART#	DESCRIPTION	QUANTITY
1	11-040	Spacer, $\frac{3}{4}$ "	2
2	HW-58	Flat Washer, $\frac{5}{8}$	32
3	26-049	Mounting Bar	1
4	26-048	Flail Bar Strap	1
	HB-38-16-100	Hex Bolt, $\frac{3}{8}$ - 16 x 1	1
	HNCL-38-16	Center Nylon Lock Nut, $\frac{3}{8}$ - 16	1
5	HHP-18	Bridge Pin, $\frac{1}{8}$	2
6	43-146	Frame	1
7	18-297	Cap Plug	2
8	HMB-58-14	Machine Bushing, $\frac{5}{8}$ x 14GA	10
9	26-047	Leveler Bar	1
10	26-041	Rasp Flail	32
11	21-260	Clevis	2
12	26-115	Mesh Finisher	1

INSTALLATION INSTRUCTIONS

1. Install flail bar strap (Ref 4) to center of mounting bar (Ref 3) with chain on top of flail bar strap and mounting bar bent away from you. Apply a light coat of lubricant to overall length of mounting bar.
2. Install one rasp flail (Ref 16) with knobby side down adjacent to sides of flail bar strap. Now install a flat washer (Ref 2) so it sits adjacent with the outside of the rasp flail. Continue to install flails with knobby sides down with washers between until you have 16 flails and washers on each side of bar strap. Force all flails tightly toward bar strap.
3. After all 32 flails have been installed, place one spacer (Ref 1) to each end of mounting bar adjacent to washer.
4. Install leveler bar (Ref 9) to mounting bar, with curved leveler bar resting on top on the smooth sides of flails. If all flails and washers do not fit snugly at this time, remove leveler bar and install enough machine bushings to ensure a snug fit. Then reinstall leveler bar.
5. Lay the frame (Ref 6) on the floor or bench with welded tabs facing up. Install ends of assembled mounting bar, with knobby sides of flails up, into welded tabs on each end of frame and secure with $\frac{1}{8}$ x 1 cotter pin.
6. Install flail bar strap (Ref 4) to center tab on frame with $\frac{3}{8}$ -16 x 1 Hex Bolt and $\frac{3}{8}$ -16 center Nylon Lock Nut. Loose fit is required. Do not over tighten.
7. Flip assembly over so knobby sides of flails are now facing down. Install hitch to frame with clevis pin (Ref 3) and cotter pin (Ref 24). The hitch should be attached to the frame as shown.
8. Install bar strap chain over welded pin on frame. Install leveler bar chain on to pin and secure in place with bridge pin. Use last bridge pin and clevis pin to hitch field finisher to your machine.

OPERATING INSTRUCTIONS

Running attachment with all flails down, flat on the surface, will provide a leveling function. Running attachment partially raised and flails at a 20° - 40° angle in relation to the level surface, will provide a finishing function. The flails increase down pressure for desired finish. Drive in wide circular patterns and increase or decrease ground speed to achieve desired finish.

43-043 FINISHING BRUSH KIT DRAWING

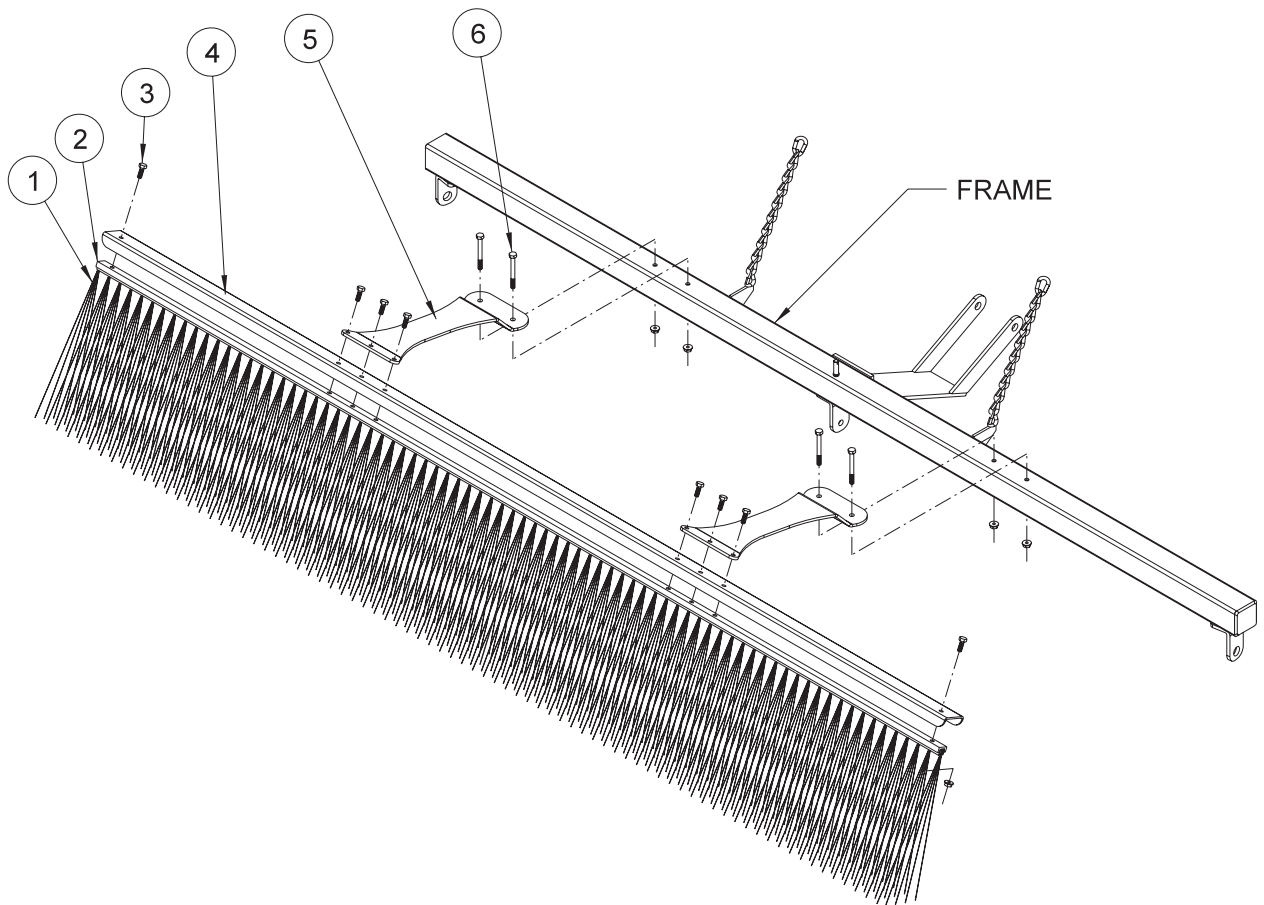

REF#	PART#	DESCRIPTION	QUANTITY
1	13-682	Brush, 77 x 11	1
2	13-683	Brush Track	1
3	HB-14-20-075	Hex Bolt, 1/4 - 20 x 3/4	8
	HNFL-14-20	Flange Whiz-Loc Nut, 1/4 - 20	8
4	13-688	Brush Channel	1
5	13-681	Mount Bracket	2
6	HB-14-20-250	Hex Bolt, 1/4 - 20 x 2 1/2	4
	HNFL-14-20	Flange Whiz-Loc Nut, 1/4 - 20	4

1. Remove the mesh finisher from your unit, it will not be used with the brush.
2. Place the brush (Ref 1) into the brush track (Ref 2). Place the brush channel (Ref 4) between the brush track and the mounting brackets (Ref 5). Now Hex Bolt the mounting brackets (Ref 5) to the brush track using the 1/4 - 20 x 3/4" Hex Bolts and 1/4 - 20 flange whiz-Nylon Lock Nuts (Ref 3).
3. Mount the brush assembly to the frame using the four 1/4 - 20 x 2 1/2" Hex Bolts and 1/4 - 20 flange whiz-Nylon Lock Nuts (Ref 5).

43-008 DRAG MAT DRAWING

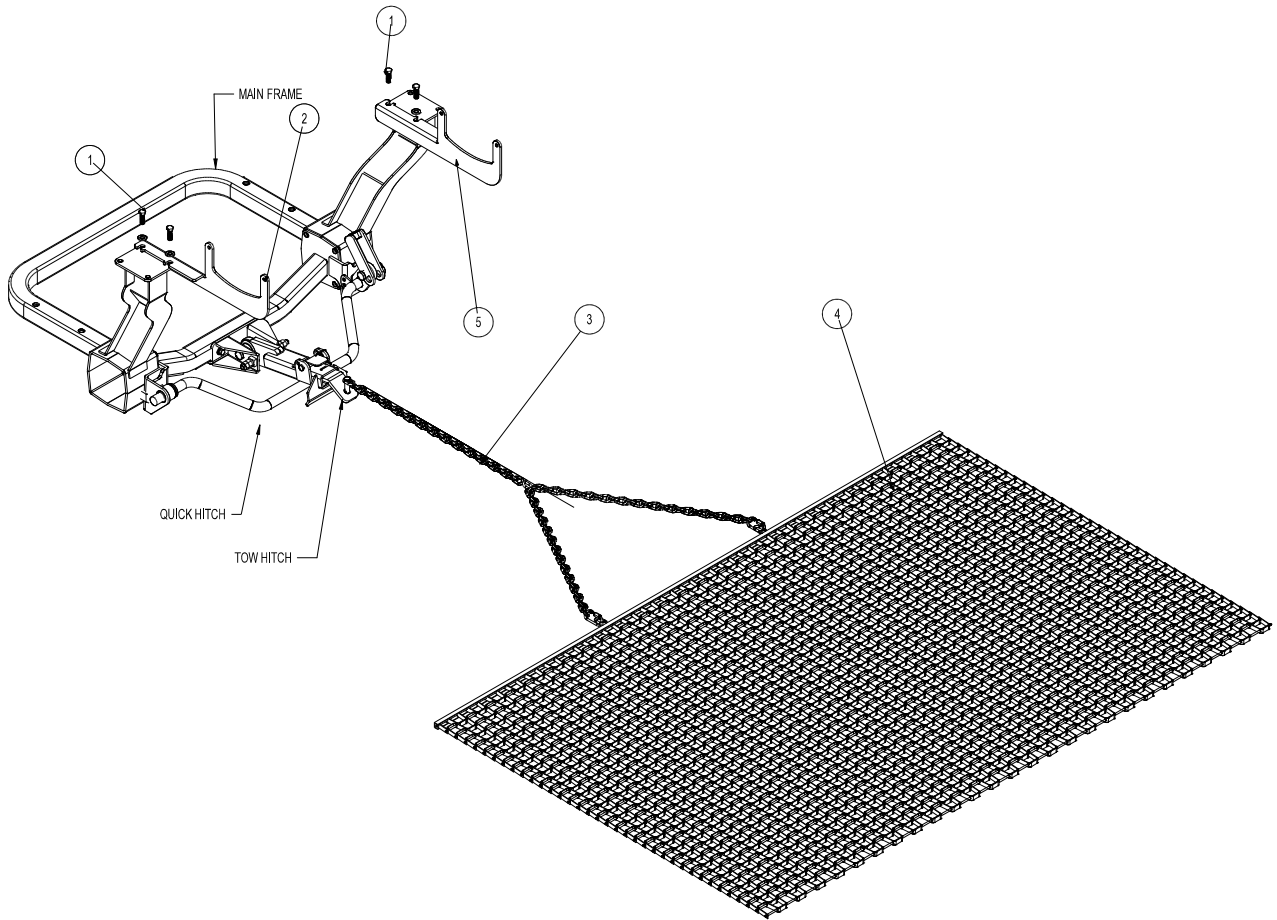

REF#	PART#	DESCRIPTION	QUANTITY
1	HB-716-14-125	Hex Bolt, $\frac{7}{16}$ - 14 x $1\frac{1}{4}$	4
	HW-716	Flat Washer, $\frac{7}{16}$	4
	HNTL-716-14	Nylon Lock Nut, $\frac{7}{16}$ -14	4
2	13-751	Right Carrier Mount	1
3	19-605	Drag Mat Chain	1
	HHP-18	Bridge Pin, $\frac{1}{8}$	1
4	19-601	Steel Drag Mat	1
5	13-752	Left Carrier Mount	1

1. The Drag Mat Kit can be installed on all Super Star with or without the optional Roll Bars.
2. Remove the two insides Hex Bolts from the roll bar mounts. Install the flat washers and secure right and left carrier mounts on opposite sides. Tighten all hardware.
3. Install the tow hitch insert into the quick hitch. This is where the tow chain on the drag mat attaches to the machine.

45-176 72" DRAG MAT + FINISHER BRUSH DRAWING

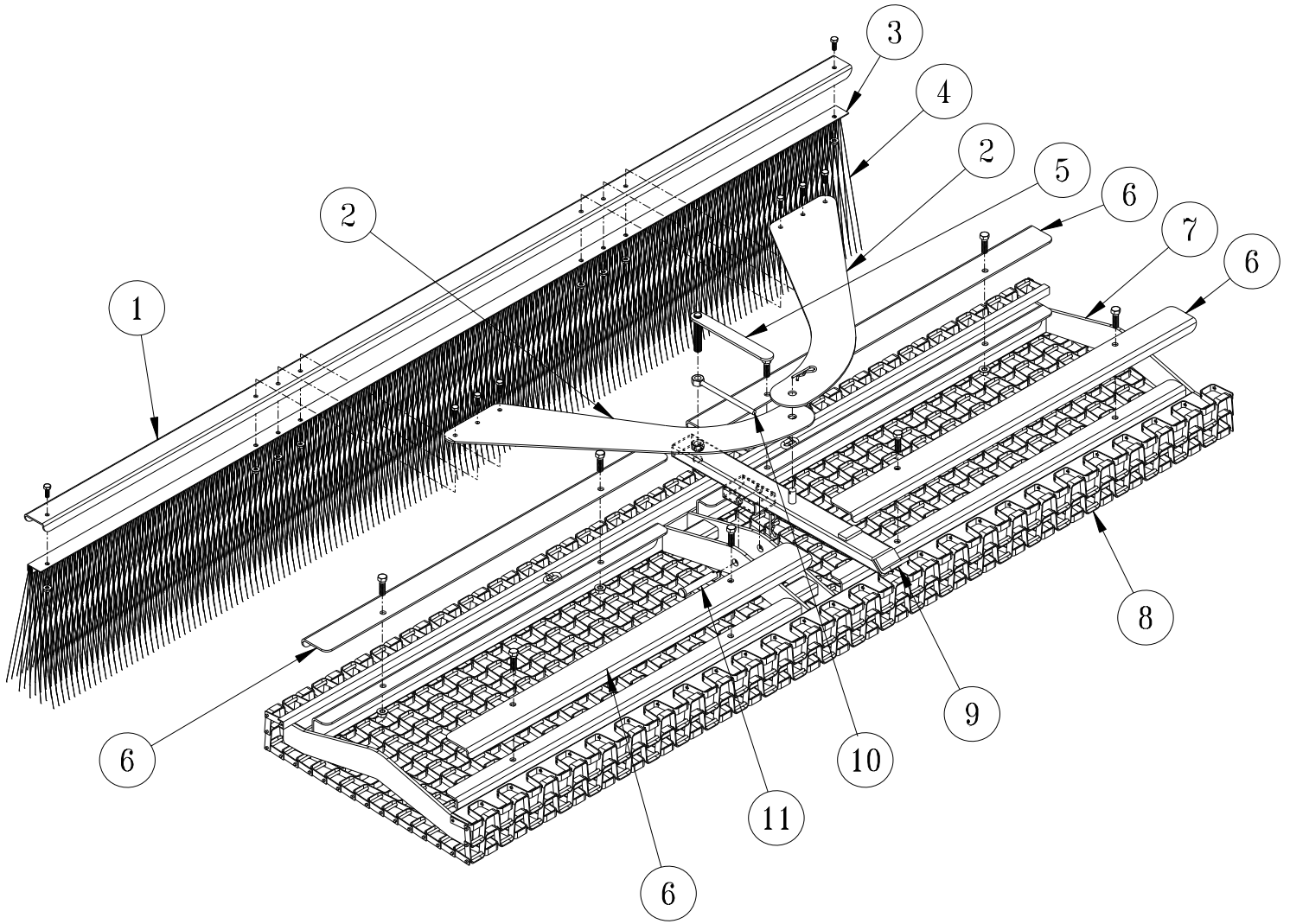

Rear Attachment

45-176 72" DRAG MAT + FINISHER BRUSH PARTS LIST

REF#	PART#	DESCRIPTION	QUANTITY
1	13-688	Brush Channel	1
	HB-14-20-075	Hex Bolt, $\frac{1}{4}$ - 20 x $\frac{3}{4}$	2
	HNFL-14-20	Flange Whiz-Loc Nut, $\frac{1}{4}$ - 20	2
2	43-168	Brush Mount Arm	2
	HB-14-20-075	Hex Bolt, $\frac{1}{4}$ - 20 x $\frac{3}{4}$	8
	HNFL-14-20	Flange Whiz-Loc Nut, $\frac{1}{4}$ - 20	8
3	13-683	Brush Track	1
4	13-682	Brush, 77 x 11	1
5	43-164	Adjustment Handle	1
6	43-166	Mat Clamp	4
	HB-38-16-125	Hex Bolt, $\frac{3}{8}$ - 16 x $1\frac{1}{4}$	8
	HNFL-38-16	Flange Whiz-Loc Nut, $\frac{3}{8}$ - 16 x $1\frac{1}{4}$	8
7	43-165	Frame	1
8	45-167	Steel Mat, 72 x 29	1
9	43-162	Draw Bar	1
	HHP-18	Bridge Pin, $\frac{1}{8}$	1
10	43-163	Lock Handle	1
11	HCP-12-300	Clevis Pin, $\frac{1}{2}$ x 3	1
	HHP-18	Bridge Pin, $\frac{1}{8}$	1

DRAG MAT ASSEMBLY INSTRUCTIONS

Some components of your **Drag Mat + Finisher Brush** have been assembled at the factory for your convenience.

1. Start by mounting the Draw bar (Ref 9) to the Frame (Ref 7) using the Clevis Pin and Bridge Pin (Ref 11). Position the Draw bar, using either set of holes, as illustrated.
2. Next, mount the Brush assembly (Ref 1, 3 & 4) to the Brush Mount Arms (Ref 2), as illustrated, using the (6) $\frac{1}{4}$ - 20 x $\frac{3}{4}$ Hex Bolts and $\frac{1}{4}$ - 20 Flange Whiz-Loc Nuts. Secure fasteners tight.
3. The holes on each of the Brush Mount Arms will line up. Mount to the pin on the Draw bar (Ref 9) and secure using the remaining Bridge Pin.
4. Thread the Lock Handle (Ref 10) on to the Adjustment Handle (Ref 5). Thread the Adjustment Handle into the nut on top of the Draw bar (Ref 9), continuing until the threaded rod is through the Draw bar tube. Turn the Lock Handle clockwise (↻) to lock the Adjustment handle in place.

Adjusting the **Steel Mat Finisher**.

Adjusting the leading edge (front) will affect the performance of the **Finisher**. Various field compositions and conditions can benefit from fine tuning of the **Finisher's** leading edge angle.

1. Release the Lock Handle (Ref 10) by holding the Adjustment Handle (Ref 5) and turning the Lock Handle counter-clockwise (↺).
2. To raise the leading edge (front) of the **Finisher**, turn the Adjustment Handle clockwise (↻). When you obtain your desired position, turn the Lock Handle clockwise (↻) to lock the Adjustment handle in place.
3. To lower the leading edge (front) of the **Finisher**, turn the Adjustment Handle counter-clockwise (↺). When you obtain your desired position, turn the Lock Handle clockwise (↻) to lock the Adjustment handle in place.

45-010 BOX GRADER DRAWING

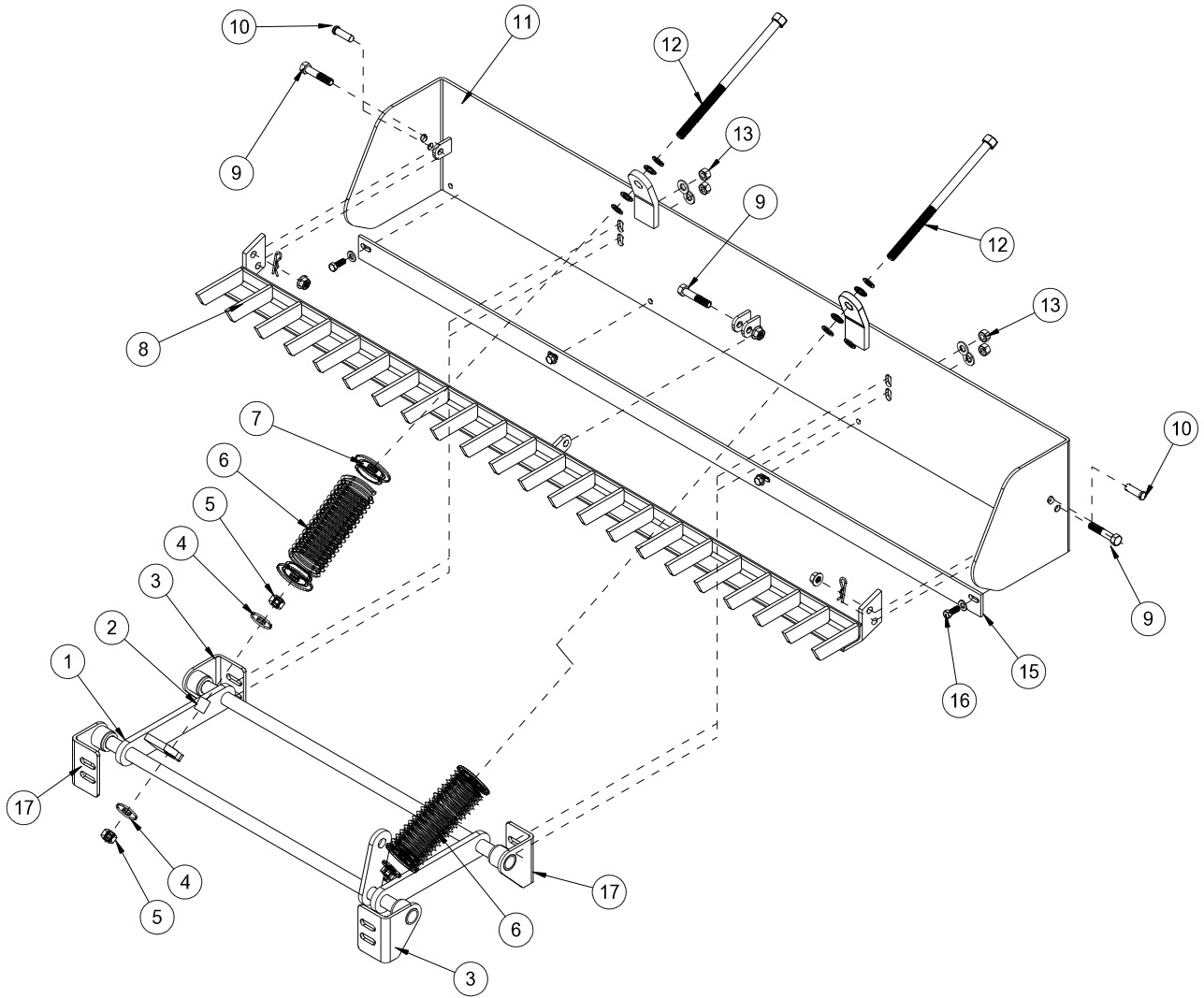

Rear Attachment

45-010 BOX GRADER PARTS LIST

REF#	PART#	DESCRIPTION	QUANTITY
1	45-141	Lift Assembly	1
2	34-215	Spacer	2
3	34-220	Right Pivot Bracket	2
	33-086	Bushing	2
4	HW-58	Flat Washer, $\frac{5}{8}$	4
5	HNTL-58-18	Nylon Lock Nut, $\frac{5}{8}$ - 18	2
	HN-58-18	Hex Nut, $\frac{5}{8}$ - 18	4
6	13-276	Compression Spring	2
7	13-277	Spring Pad	4
8	34-217	Break Up Bar	1
9	HB-12-13-200	Hex Bolt, $\frac{1}{2}$ - 13 x 2	3
	HNTL-12-13	Nylon Lock Nut, $\frac{1}{2}$ - 13	3
10	HCP-12-150	Clevis Pin, $\frac{1}{2}$ x $1\frac{1}{2}$	2
	HHP-18	Bridge Pin, $\frac{1}{8}$	2
11	34-216	Blade Assembly	1
12	34-214	Spring Rod	2
	HMB-58-14	Machine Bushing, $\frac{5}{8}$ - 14GA	4
13	HB-12-13-125	Hex Bolt, $\frac{1}{2}$ - 13 x $1\frac{1}{4}$	4
	HW-716	Flat Washer, $\frac{7}{16}$	8
	HWL-12	Lock Washer, $\frac{1}{2}$	4
	HN-12-13	Hex Nut, $\frac{1}{2}$ - 13	4
15	34-218	Cutter Blade	1
16	HB-38-16-125	Hex Bolt, $\frac{3}{8}$ - 16 x $1\frac{1}{4}$	4
	HW-38	Flat Washer, $\frac{3}{8}$	4
	HWL-38	Lock Washer, $\frac{3}{8}$	4
	HN-38-16	Nylon Lock Nut, $\frac{3}{8}$ - 16	4
17	34-219	Left Pivot Bracket	2
	33-086	Bushing	2

42-586Q GREEN STAR RBS MAIN FRAME DRAWING

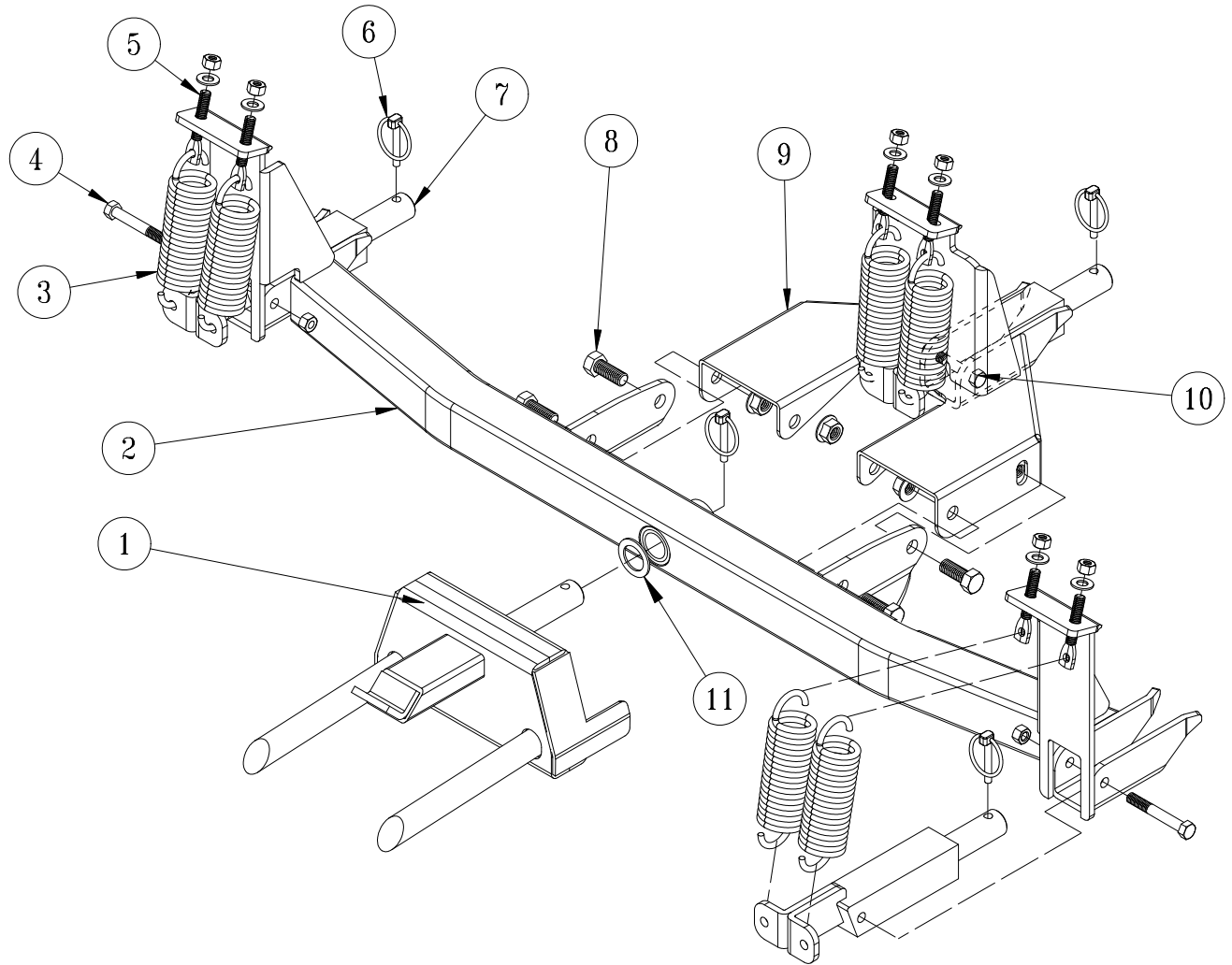

Rear Attachment

42-586Q GREEN STAR RBS MAIN FRAME PARTS LIST

REF#	PART#	DESCRIPTION	QUANTITY
1	43-155	Hitch	1
2	42-614	RBS Frame	1
	18-295	Oilite Bushing (part of 42-577)	2
3	42-536	Spring	6
4	HB-38-16-275	Bolt $\frac{3}{8}$ - 16 x $2\frac{3}{4}$	2
	HNTL-38-16	Lock Nut $\frac{3}{8}$ - 16	2
5*	42-537	Spade Bolt	6
	HW-38	Flat Washer, $\frac{3}{8}$	6
	HNTL-38-16	Lock Nut $\frac{3}{8}$ - 16	6
6	42-539	Lynch Pin $\frac{5}{16}$	4
7	42-576	Spring Tower	3
8	HB-12-13-125	Hex Bolt, $\frac{1}{2}$ - 13 x $1\frac{1}{4}$	4
	HNFL-12-13	Flange Whiz-Loc Nut, $\frac{1}{2}$ - 13	4
9	42-615	Pivot Frame	1
10	HB-38-16-250	Bolt $\frac{3}{8}$ - 16 x $2\frac{1}{2}$	1
	HNCL-38-16	Center Lock Nut $\frac{3}{8}$ - 16	1
11	HMB-100-14	Machien Bushing, 1 x 14GA	1

* There should be $\frac{3}{4}$ " thread showing above the nut on the spade bolt.

42-581 GREEN STAR RBS ROLLER SET (3) DRAWING

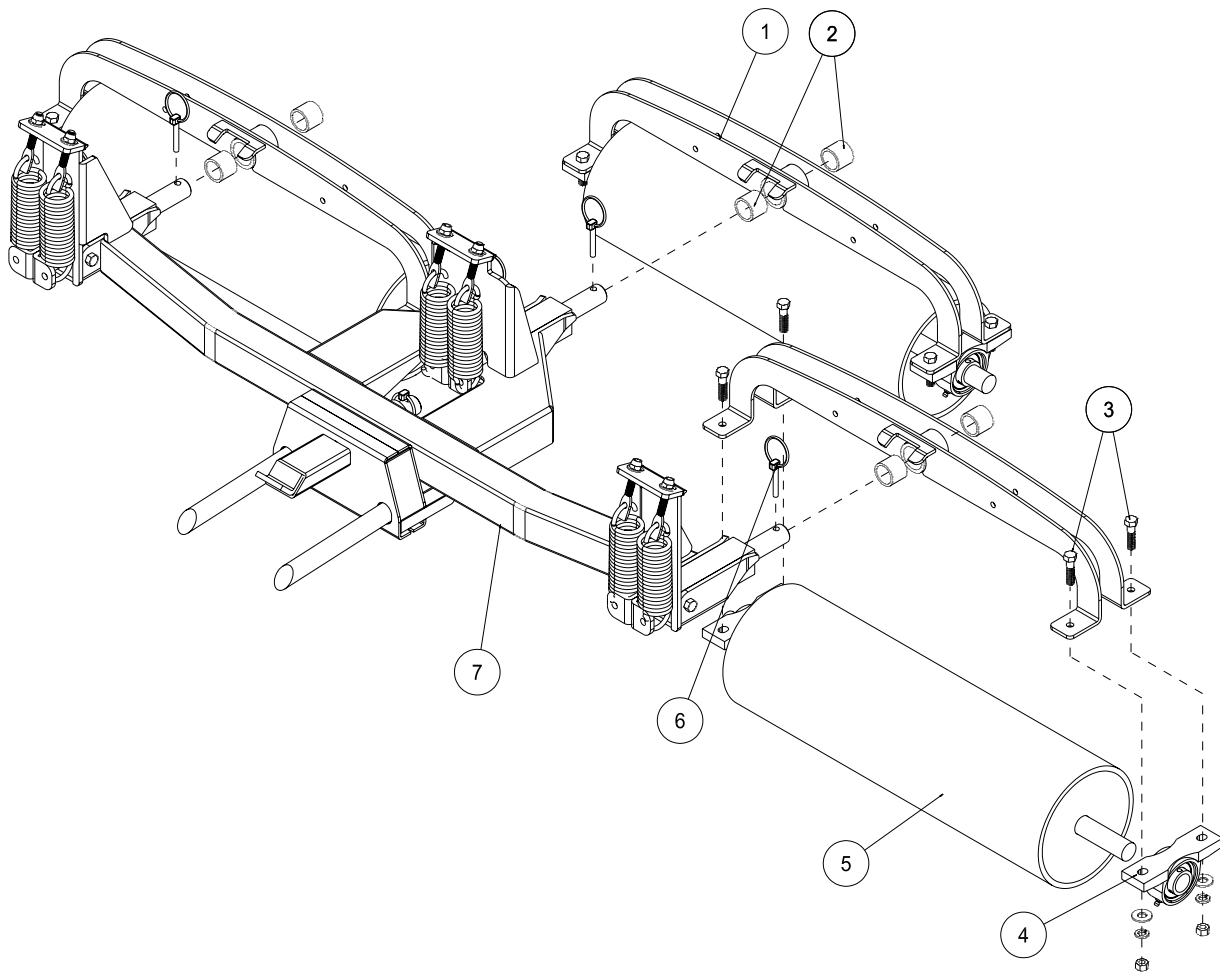

Rear Attachment

42-581 GREEN STAR RBS ROLLER SET (3) PARTS LIST

REF#	PART#	DESCRIPTION	QUANTITY
1	42-574	Fork	3
2	18-295	Oilite Bushing (part of 42-574)	6
3	HB-38-16-150	Hex Bolt, $\frac{3}{8}$ - 16 x $1\frac{1}{2}$	12
	HWL-38	Lock Washer, $\frac{3}{8}$	12
	HW-38	Flat Washer, $\frac{3}{8}$	12
	HN-38-16	Hex Nut, $\frac{3}{8}$ - 16	12
4	11-094	Pillow Block	6
5	42-584	Roller	3
6	42-539	Lynch Pin, $\frac{5}{16}$ (part of main frame)	3
7	42-586Q	Green Star RBS Main Frame	1

ADJUSTMENTS AND OPERATION INSTRUCTIONS

ADJUSTMENT

The springs are preset for maximum down pressure, and should not need to be adjusted. If you feel the need to adjust the springs please call for further instructions. The unit comes pre-adjusted for most models. The four adjustment holes on the hitch are for making sure all three rollers are touching the ground at the same pressure. When installing roller system start with the lower mounting holes on hitch.

Tire pressure should be 4 psi in the front and 7 psi in the rear tire for best traction.

OPERATION

Make sure the rolling system has been installed and adjusted properly for your model of bunker rake. Always transport in fully raised position. Always remove flag pole before rolling green. Do not stop on green while rolling. Do not roll up steep slopes or loss of traction may result. Do not turn while rolling.

To begin rolling, lower unit all the way down as you come across collar and continue straight across green until reaching other collar and raise as you come off of green. Overlap stripes the same as if you were mowing.

42-585 GREEN STAR RBS BRUSH SET (3) DRAWING

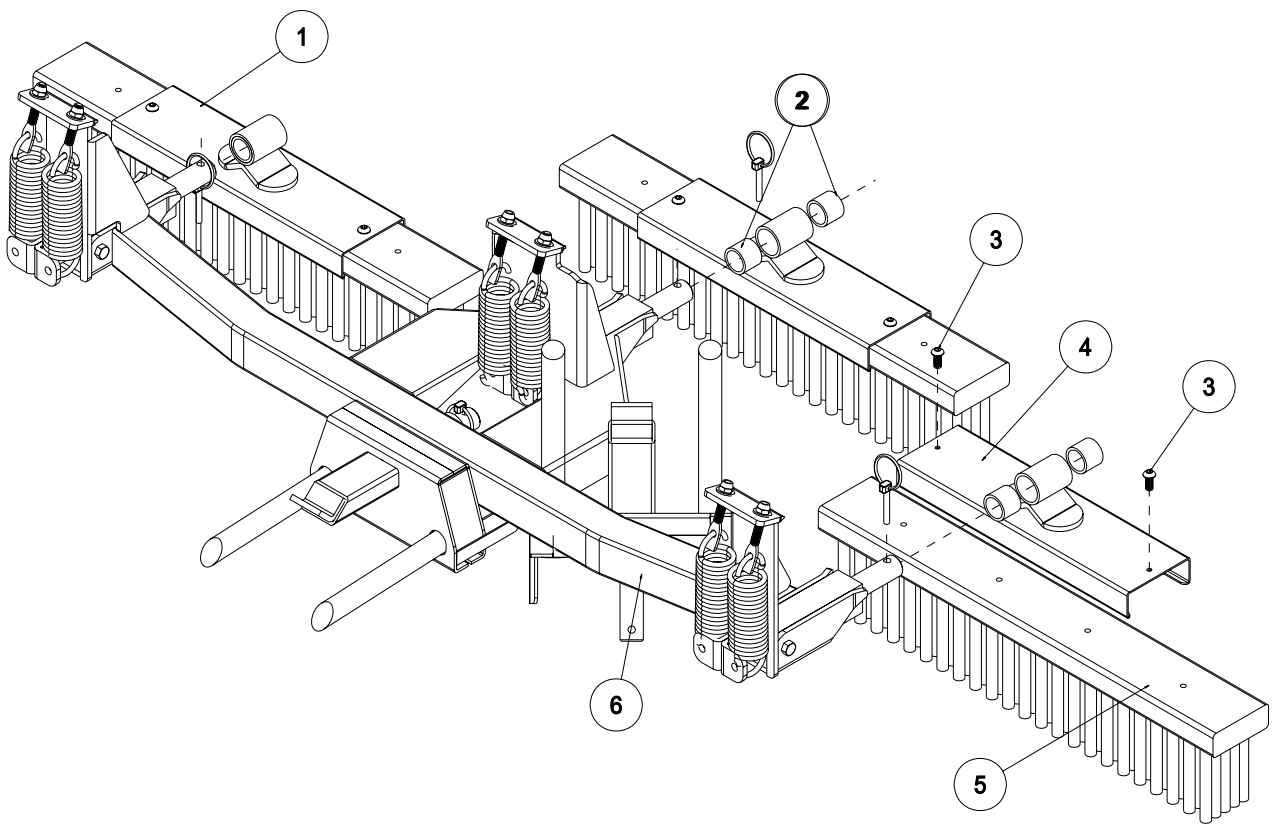

Rear Attachment

42-585 GREEN STAR RBS BRUSH SET (3) PARTS LIST

REF#	PART#	DESCRIPTION	QUANTITY
1	42-539	Lynch Pin, $\frac{5}{16}$ (part of main frame)	4
2	18-295	Oilite Bushing (part of 42-579)	6
3	HSD-8-075	Phillip Head Screw, #8 x $\frac{3}{4}$	6
4	42-579	Brush Bracket	3
5	42-545	Brush Head	3
6	42-586Q	Green Star RBS Main Frame	1

ADJUSTMENTS AND OPERATION INSTRUCTIONS

ADJUSTMENT

The springs are preset for maximum down pressure, and should not need to be adjusted. If you feel the need to adjust the springs please call for further instructions. The unit comes pre-adjusted for most models. The four adjustment holes on the hitch are for making sure all three brushes are touching the ground at the same pressure. When installing brush system start with the lower mounting holes on hitch.

Tire pressure should be 4 psi in the front and 7 psi in the rear tire for best traction.

OPERATION

Make sure the brush system has been installed and adjusted properly for your model of bunker rake. Always transport in fully raised position. Always remove flag pole before brushing green. Do not stop on green while brushing. Do not brush up steep slopes or loss of traction may result. Do not turn while brushing.

For drag brushes use hydraulics to control the amount of down pressure required to move your top dressing material. We recommend reversing drag brushes after each use for even wear. To begin brushing, lower unit as you come across collar and continue straight across green until reaching other collar and raise as you come off of green. Overlap stripes the same as if you were mowing.

42-582 GREEN STAR RBS SPIKER SET (3) DRAWING

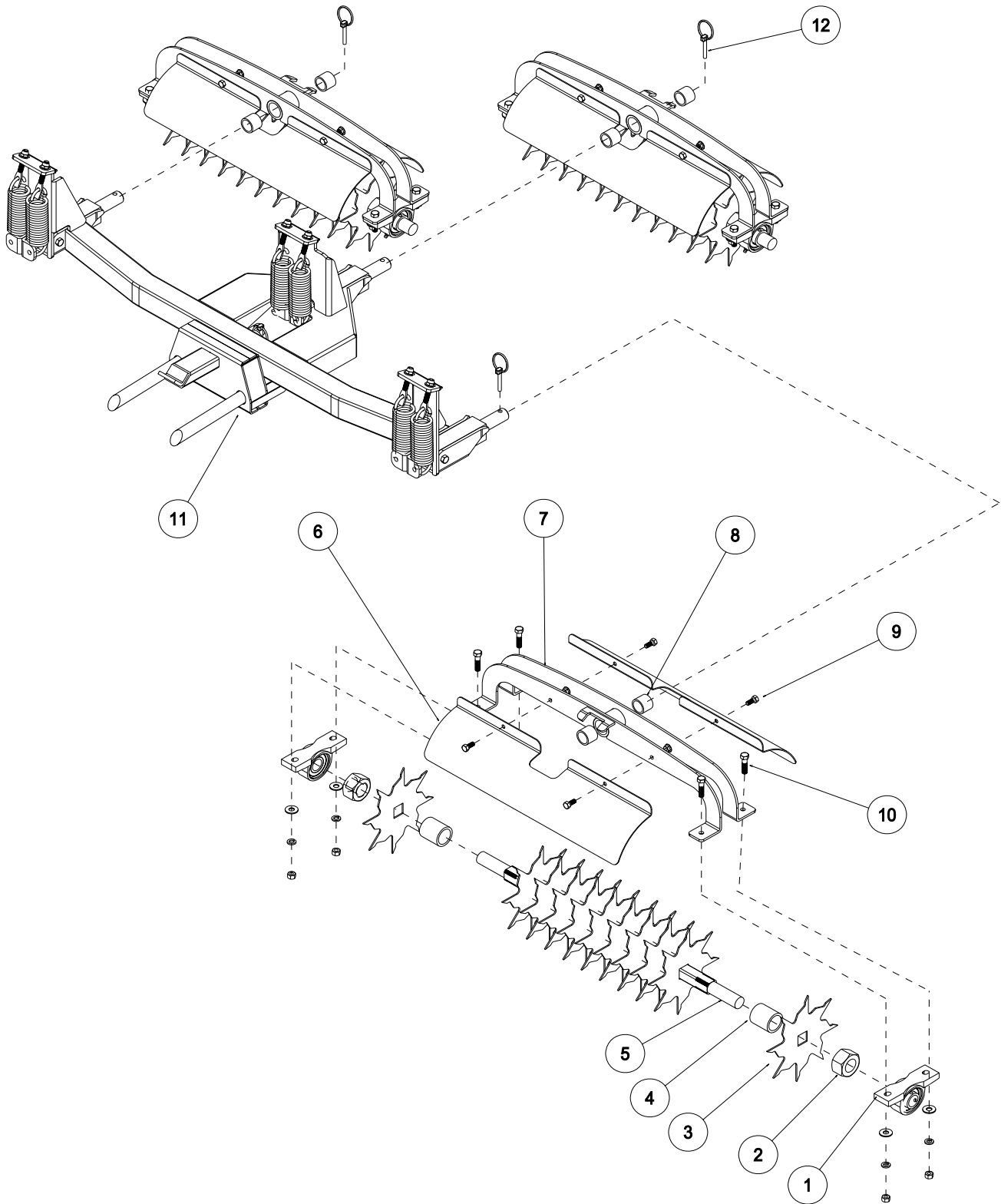

Rear Attachment

42-582 GREEN STAR RBS SPIKER SET (3) DRAWING

REF#	PART#	DESCRIPTION	QUANTITY
1	11-094	Pillow Block	6
2	HNJ-114-12	Jam Nut, 1 ¹ / ₄ - 12	6
3	42-583	Spiker Blade	33
4	8965-1.875	Spiker Blade Spacer (1.875")	30
5	42-554	Spiker Shaft	3
6	42-578	Spiker Cover	6
7	42-574	Fork	3
8	18-295	Oilite Bushing (part of 42-574)	6
9	HB-516-18-075	Hex Bolt, ⁵ / ₁₆ - 18 x ³ / ₄	12
	HNTL-516-18	Nylon Lock Nut, ⁵ / ₁₆ - 18	12
10	HB-38-16-150	Hex Bolt, ³ / ₈ - 16 x 1 ¹ / ₂	12
	HWL-38	Lock Washer, ³ / ₈	12
	HW-38	Flat Washer, ³ / ₈	12
	HN-38-16	Hex Nut, ³ / ₈ - 16	12
11	42-586Q	Green Star RBS Main Frame	1
12	42-539	Lynch Pin, ⁵ / ₁₆ (part of main frame)	3

ADJUSTMENTS AND OPERATION INSTRUCTIONS

ADJUSTMENT

The springs are preset for maximum down pressure, and should not need to be adjusted. If you feel the need to adjust the springs please call for further instructions. The unit comes pre-adjusted for most models. The four adjustment holes on the hitch are for making sure all three spikers are touching the ground at the same pressure. When installing spiker system start with the lower mounting holes on hitch.

Tire pressure should be 4 psi in the front and 7 psi in the rear tire for best traction.

OPERATION

Make sure the spiker system has been installed and adjusted properly for your model of bunker rake. Always transport in fully raised position. Always remove flag pole before spiking green. Do not stop on green while spiking. Do not spike up steep slopes or loss of traction may result. Do not turn while spiking.

To begin spiking, lower unit all the way down as you come across collar and continue straight across green until reaching other collar and raise as you come off of green. Overlap stripes the same as if you were mowing.

INSTALLATION

Spiker blades must be installed so that the jagged side of the tooth cuts into the turf first. This allows only a piercing of the turf, whereas if the straight edge of the spiker blades enters first it will act more as a cutting effect.

43-009 72" COCO MAT FINISHER DRAWING

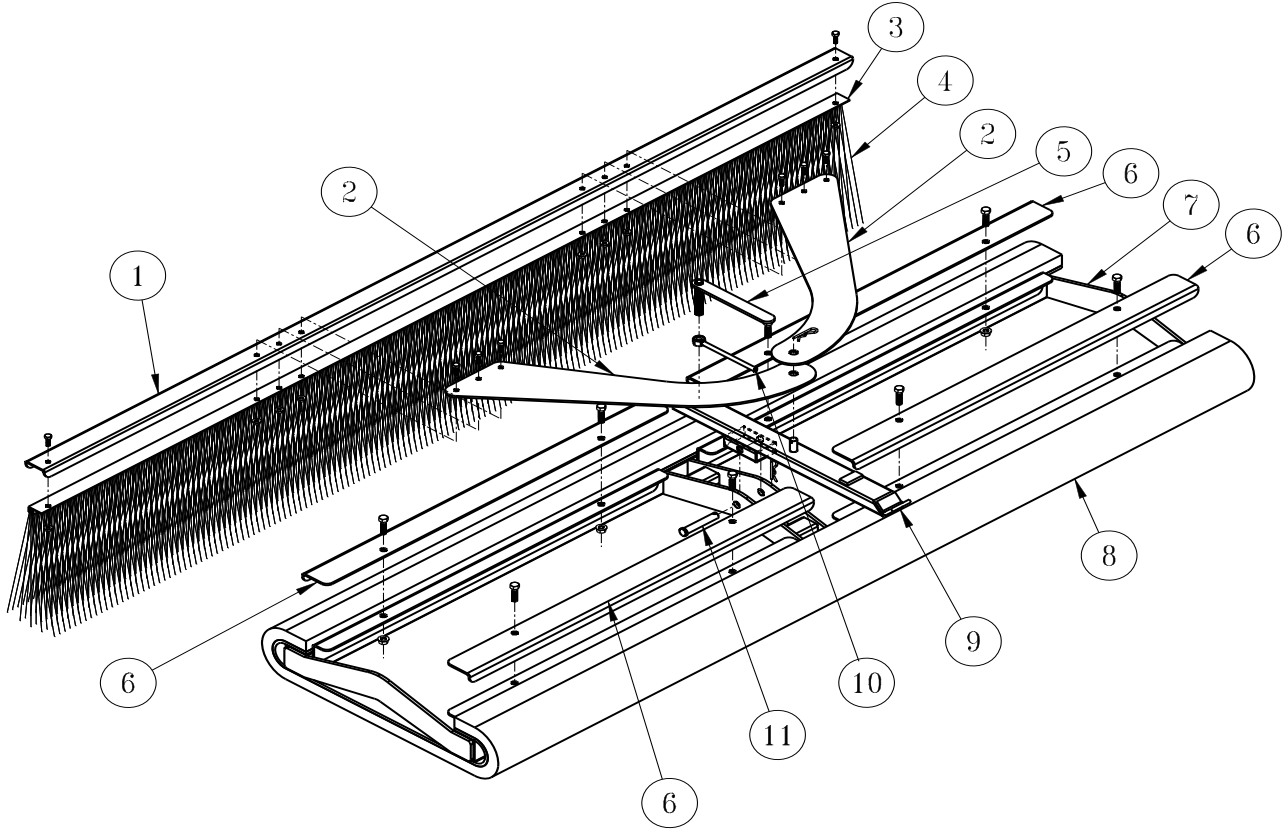

Rear Attachment

72" COCO MAT FINISHER PARTS LIST

REF#	PART#	DESCRIPTION	QUANTITY
1	13-688	Brush Channel	1
	HB-14-20-075	Hex Bolt, $\frac{1}{4}$ - 20 x $\frac{3}{4}$	2
	HNFL-14-20	Flange Whiz-Loc Nut, $\frac{1}{4}$ - 20	2
2	43-168	Brush Mount Arm	2
	HB-14-20-075	Hex Bolt, $\frac{1}{4}$ - 20 x $\frac{3}{4}$	6
	HNFL-14-20	Flange Whiz-Loc Nut, $\frac{1}{4}$ - 20	6
3	13-683	Brush Track	1
4	13-682	Brush, 77 x 11	1
5	43-164	Adjustment Handle	1
6	43-166	Mat Clamp	4
	HB-38-16-125	Hex Bolt, $\frac{3}{8}$ - 16 x $1\frac{1}{4}$	8
	HNFL-38-16	Flange Whiz-Loc Nut, $\frac{3}{8}$ - 16 x $1\frac{1}{4}$	8
7	43-165	Frame	1
8	43-167	Coco Mat, 27 x 72	1
9	43-162	Draw Bar	1
	HHP-18	Bridge Pin, $\frac{1}{8}$	1
10	43-163	Lock Handle	1
11	HCP-12-300	Clevis Pin, $\frac{1}{2}$ x 3	1
	HHP-18	Bridge Pin, $\frac{1}{8}$	1

Some components of your **Coco Mat Finisher** have been assembled at the factory for your convenience.

1. Start by mounting the Draw bar (Ref 9) to the Frame (Ref 7) using the Clevis Pin and Bridge Pin (Ref 11). Position the Draw bar, using either set of holes, as illustrated.
2. Next, mount the Brush assembly (Ref 1, 3 & 4) to the Brush Mount Arms (Ref 2), as illustrated, using the (6) $\frac{1}{4}$ - 20 x $\frac{3}{4}$ Hex Bolts and $\frac{1}{4}$ - 20 Flange Whiz-Loc Nuts. Secure fasteners tight.
3. The holes on each of the Brush Mount Arms will line up. Mount to the pin on the Draw bar (Ref 9) and secure using the remaining Bridge Pin.
4. Thread the Lock Handle (Ref 10) on to the Adjustment Handle (Ref 5). Thread the Adjustment Handle into the nut on top of the Draw bar (Ref 9), continuing until the threaded rod is through the Draw bar tube. Turn the Lock Handle clockwise (↻) to lock the Adjustment handle in place.

Adjusting the **Coco Mat Finisher**.

Adjusting the leading edge (front) will affect the performance of the **Finisher**. Various field compositions and conditions can benefit from fine tuning of the **Finisher's** leading edge angle.

1. Release the Lock Handle (Ref 10) by holding the Adjustment Handle (Ref 5) and turning the Lock Handle counterclockwise (↺).
2. To raise the leading edge (front) of the **Finisher**, turn the Adjustment Handle clockwise (↻). When you obtain your desired position, turn the Lock Handle clockwise (↻) to lock the Adjustment handle in place.
3. To lower the leading edge (front) of the **Finisher**, turn the Adjustment Handle counterclockwise (↺). When you obtain your desired position, turn the Lock Handle clockwise (↻) to lock the Adjustment handle in place.

43-170 RAHN GROOMER

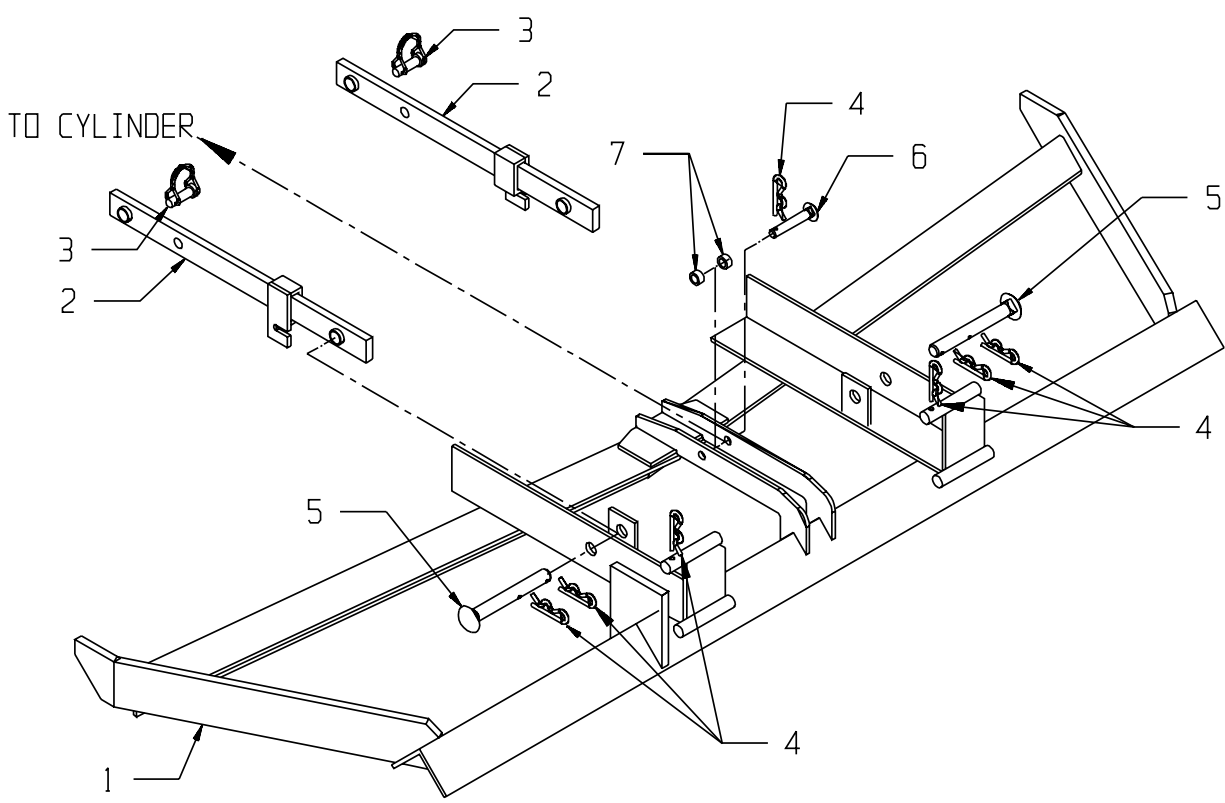

Base Unit, Infield Groomer

REF#	PART#	DESCRIPTION	QUANTITY
1	GL650-1	Groomer Frame	1
2	GL650-3	Pull Arms, Set (includes 2 arms)	1
3	HP8-09-01	Pull Arm Locking Pins, Set (included 2 pins)	1
4	HP-8-10	Hitch Pin	7
5	HP-8-02	6" Mounting Pin Set.(Included 2 pins)	1
6	HP8-03	Mounting Pin, 3" x 1/2"	1
7	HP-8-382	Spacer (Set of 2)	1

Rear Attachment

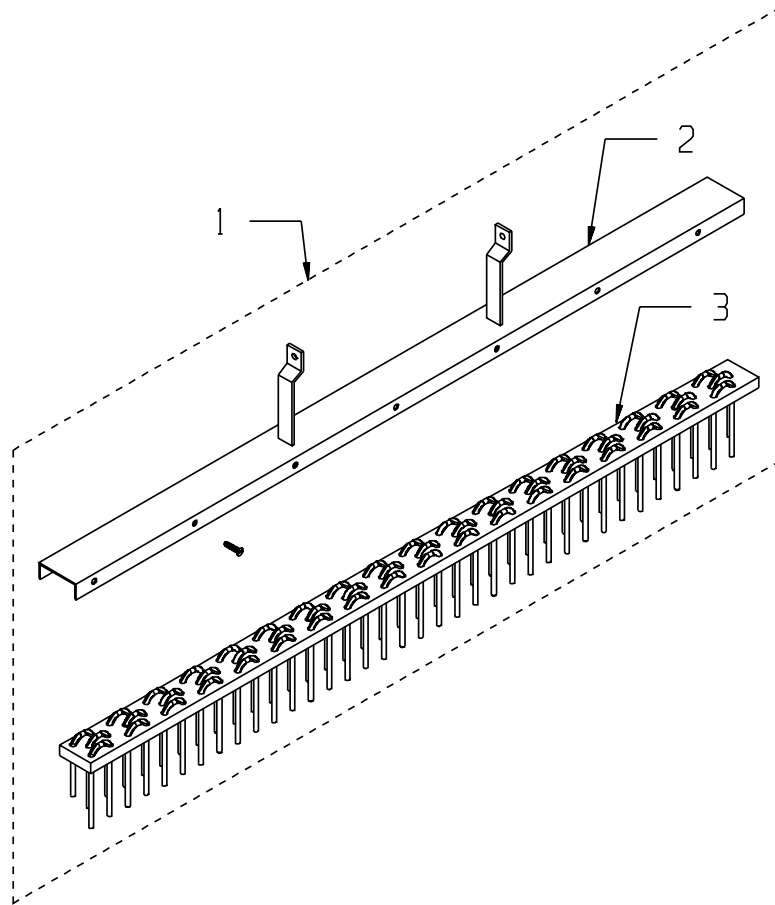

6' Broom Assembly

REF#	PART#	DESCRIPTION	QUANTITY
1	GL650-6	Broom Assembly, Complete	1
2	GL650-6-2	Broom Channel with Arms	1
3	GL650-6-1	Replacement Broom	1

43-170 RAHN GROOMER

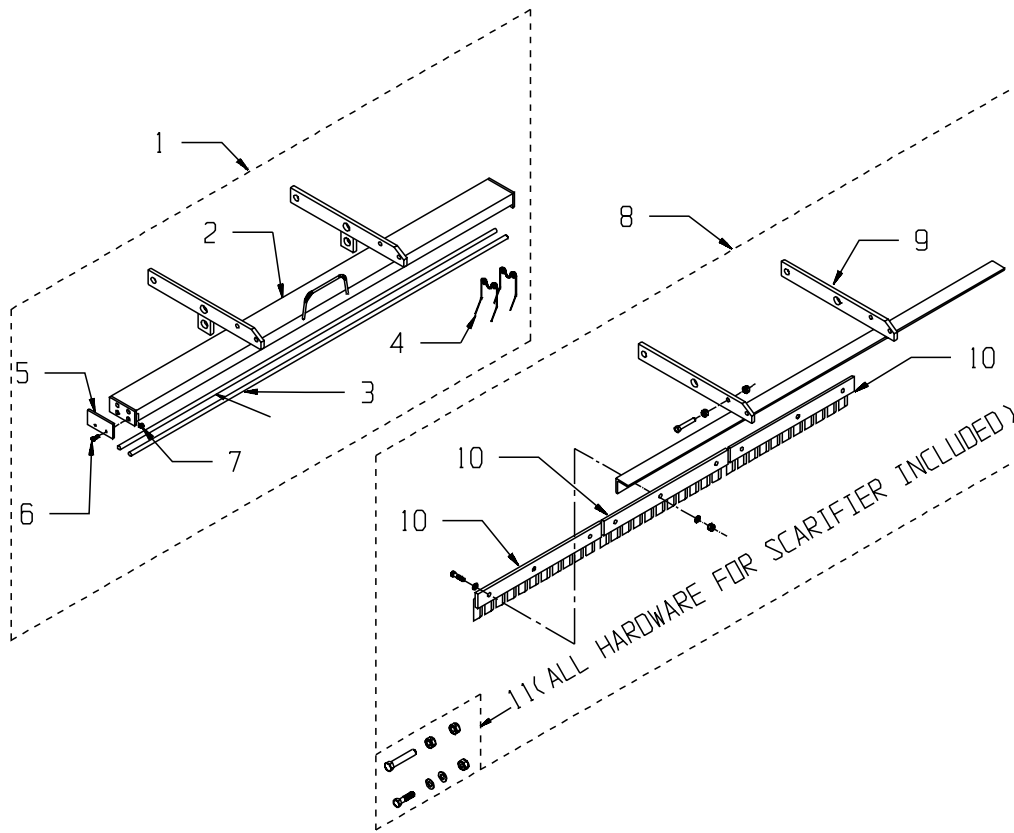

Scarifier Options

REF#	PART#	DESCRIPTION	QUANTITY
1	GL650-4-10	Spring Tine Assembly, Complete	1
2	GL650-4-10-1	Spring Tine Channel with Arms	1
3	GL650-4-10-2	Rods, 1/2" x 60"	2
4	GL650-4-15	Spring Tine Replacement Set (includes 38 pcs)	1
5	GL650-4-10-3	End Cap	1
6		HHCS, 1/4 x 3/4	2
7		Nylon Lock Nut, 1/4	2
8	GL650-4	Scarifier Assembly	1
9	GL650-4-1-1	5 Foot Scarifier Angle	1
10	GL650-4-5-3	Scarifier Replacement Set	1
11	GL650-4-9	Hardware Package	1



Picture #1



Picture #2

SMITHCO QUICK ATTACH MOUNTING INSTRUCTIONS

- 1. INSTALL RAHN CENTER LIFT ASSEMBLY INTO THE SMITHCO QUICK ATTACH MOUNTING SLOT UNTIL IT ENGAGES WITH THE SPRING ASSISTED STOP. MAKE SURE THE 3/4" RODS ARE BELOW THE QUICK ATTACH CROSS MEMBER. (PICTURE #1)**
- 2. INSTALL THE RAHN PULL ARM BRACKETS (LEFT & RIGHT) ON TOP OF THE BRACKETS USED FOR THE QUICK ATTACH SYSTEM USING THE HARDWARE PROVIDED. WHEN INSTALLING THE BRACKETS, THE HEX BOLT HOLES ARE LOCATED TOWARD THE WHEELS AND THE EARS OF THE BRACKET ARE TO THE INSIDE.**
- 3. REMOVE CLEVIS PIN IN THE ROD END OF THE CYLINDER. INSTALL CYLINDER MOUNT EXTENDER OVER EXISTING EAR ON CROSS MEMBER. TIGHTEN HEX BOLT AND REPLACE PIN. (PICTURE #2)**

TYPHOON DRAWING

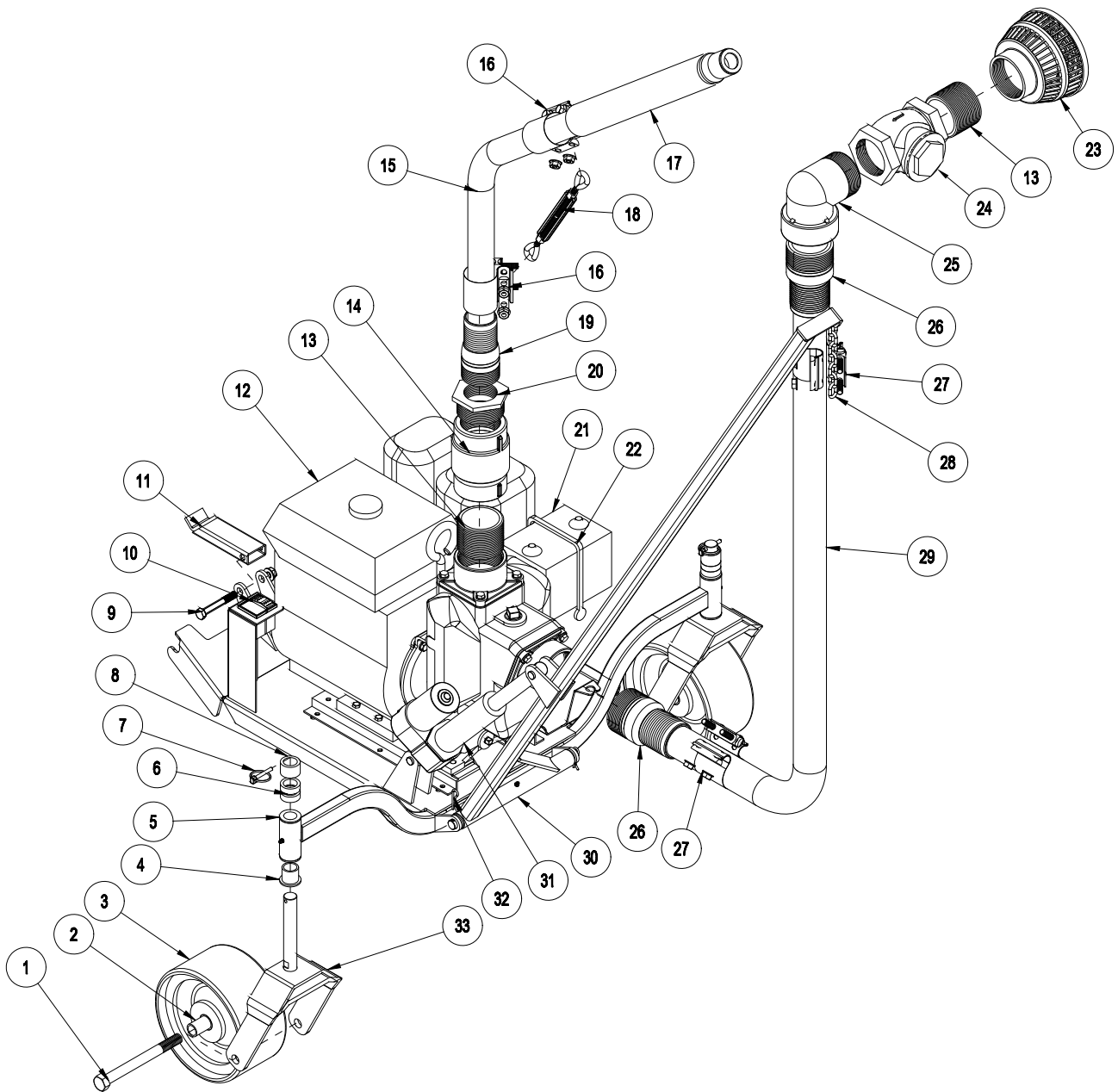

Rear Attachment

TYPHOON PARTS LIST

REF#	PART#	DESCRIPTION	QUANTITY
1	HB-34-10-800	Hex Bolt, $\frac{3}{4}$ - 10 x 8	2
	HNTL-34-10	Nylon Lock Nut, $\frac{3}{4}$ -10	2
2	72-135	Castor Wheel Spacer	4
3	78-012	Tire and Wheel	2
4	18-223	Flange Bushing (part of 41-520)	4
5	41-520	Frame	1
6	29-584	Adjustment Spacer, $\frac{1}{2}$ "	4
7	42-539	Lynch Pin	2
8	29-585	Adjustment Spacer, 1"	2
9	HB-12-13-350	Hex Bolt, $\frac{1}{2}$ -13 x $3\frac{1}{2}$	1
	HNTL-12-13	Nylon Lock Nut, $\frac{1}{2}$ - 13	1
10	15-725	Mount Panel End	2
	15-727	Switch Actuator, no light	1
	15-728	Switch Body, On-Off-On	1
	15-730	Mount Panel Plug	1
11	41-522	Quick Hitch Bar	1
12	41-532	Pump with 11 HP Honda Engine	1
	41-532-01	Impeller, Wear Plate, Gasket and Seal	1
	41-532-02	Gasket	1
	41-532-03	Seal	1
13	18-376	Close Nipple, 3"	2
14	41-530	Swivel Joint, 3"	1
15	18-382	2.5" Suction Hose	1
16	41-527	Band Clamp, 2.5"	2
17	41-529	Discharge Tube	1
18	41-525	Turnbuckle	1
19	18-375	King Nipple, 2.5"	1
20	18-378	Bushing, 3" x 2.5"	1
21		U-1 300 Amp Battery (not supplied)	1
22	8-603	Battery Strap	1
23	41-531	3" Basket Strainer	1
24	18-380	Check Valve, 3"	1
25	18-379	Plastic Elbow	1
26	18-374	King Nipple, 3"	1
27	41-526	Band Clamp, 3"	2
28	8820-8	Machine Chain, 8 links	1
29	18-381	3" Suction Hose	1
30	41-521	Hose Boom	1
	HG-14-28-180	Grease Fitting, $\frac{1}{4}$ - 28 x 180°	1
31	16-754	Actuator with 8" Stroke	1
	HCP-12-225	Clevis Pin, $\frac{1}{2}$ x $2\frac{1}{4}$	2
	HP-18-100	Cotter Pin, $\frac{1}{8}$ x 1	2
32	41-523	Pivot Rod	1
	HHP-18	Bridge Pin, $\frac{1}{8}$	2
33	72-134	Castor Wheel	1

TYPHOON WIRING

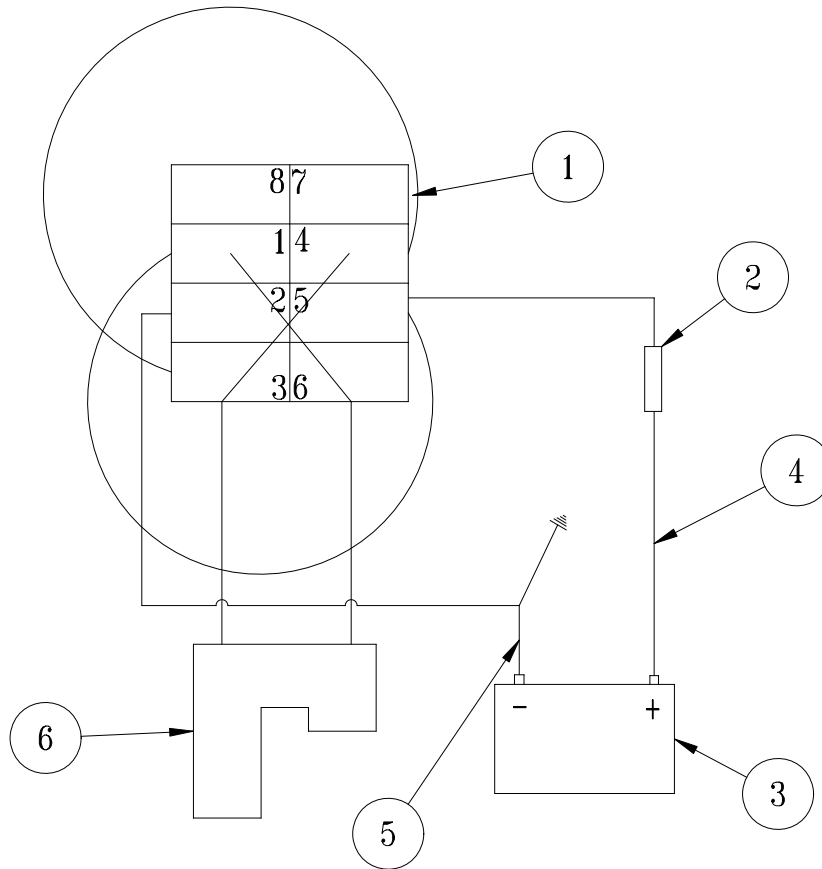

WIRING PARTS LIST

REF#	PART#	DESCRIPTION	QUANTITY
1	15-727	Switch Actuator, no light	1
	15-728	Switch Body, On-Off-On	1
2	77-261	Circuit Breaker, 40 amp	1
	8977	Circuit Breaker Boot	1
3		U-1 300 Amp Battery (not supplied)	1
4	22-056	Cable	1
	12-031	Battery Boot	1
5	22-065	Starter Cable	1
6	16-754	Actuator	1
	41-524	Wire Harness	1
	16-088	Decal, Moving Parts Hot	1
	25-286	Decal, Pinch Points	2
	25-298	Decal, Warning, Hot	1

Rear Attachment

 **WARNING**

READ ENGINE MANUAL PRIOR TO STARTING THIS MACHINE.
Machine is shipped with NO OIL in engine.
Fill Engine with oil as suggested in Engine Manual.

1. You must prime pump before starting the engine. To do so, insert garden hose in Discharge Tube and fill system to full. Full is when you see water in both suction hoses.
2. Fill engine up with 4-stroke motor oil as advised in the engine manual.
3. Install a U-1 300 Amp Battery into the battery box on the right side of the engine. Connect battery cables and strap battery into place.
4. Make yourself familiar with engine controls located on the engine by reading the Engine Owner's Manual.
5. Once the pump is primed, battery installed, and the engine oil is filled you may hook the Typhoon up to the Super Star Bunker Rake.
6. The Typhoon is equipped with a quick hitch attachment. Insert quick hitch bar into hitch on Super Star and lock in place with lock pin.
7. There are 1/2" and 1" spacers on the castor wheels that can be arranged in any combination to achieve the desired height. Please keep both side adjusted the same.
8. Transport the Typhoon to the water hole that needs to be siphoned. Back Typhoon to edge of water.
9. Using the rocker switch on the left side of the engine, lower the boom and suction screen into the water.
10. Stand clear of the discharge tube. Make sure the discharge tube is pointing in a direction that is free of bystanders and buildings.
11. Start engine. There will be immediate water discharge from the discharge tube. There is a swivel tube that allows you to turn the discharge in any direction you desire. There is also a turnbuckle that can be lengthened to give a longer flow or shortened for a closer distance. For best performance keep hand on discharge tube to prevent it from straying.
12. When water is siphoned, shut off engine, leaving water in the pump and discharge hose, so you do not run the pump dry.

 **WARNING**

DO NOT RUN THE PUMP DRY!

13. Using the rocker switch, raise boom out of the water hole.

41-532 PUMP REPLACEMENT PARTS LIST

REF#	PART#	DESCRIPTION	QUANTITY
1	41-532-07	NPT Outlet Flange	1
2	41-532-05	NPT Inlet Flange	1
3		Adapter for Gas Engine	1
4	41-532-10	Plug	1
5*		Impeller & Drive Shaft for Gas Engine	1
6	41-532-11	Plug	1
7		$\frac{5}{8}$ SS Jam Nut	1
8*		Wear Plate	1
9	41-532-06	EPDM Outlet Gasket	1
10	41-532-04	Gasket Check Valve Assembly	1
11*	41-532-02	Adapter Gasket	1
12		$\frac{3}{8}$ -16 x $1\frac{1}{8}$ SS Cap Screw HXHD	8
13		Handle	1
14		Clamp Assembly	1
15	41-532-08	Pump Housing	1
16		$\frac{3}{8}$ - 24 x $2\frac{1}{4}$ Hex Bolt	2
17*		Wear Plate Flat Head Screw	2
18		$\frac{3}{8}$ Lock Washer	8
19		$\frac{3}{8}$ x 24 SS Hex Nut	1
20		1" Shaft	1
21		Bearing Pedestal	2
22		Hex Bolt	4
23*	41-532-03	Viton Seal Assembly	1
24		$\frac{3}{8}$ - 16 SS Hex Nut	6
25		$\frac{3}{8}$ SS Lock Washer	6
26		$\frac{3}{8}$ - 16 x $\frac{3}{8}$ -24 x $1\frac{1}{2}$ SS Stud	6
27	41-532-12	O-ring	1
28	41-532-13	O-ring	1
	41-532-01	Repair Kit (includes * items)	

The Smithco Commercial Products Two-Year Limited Warranty

Smithco, Inc. (Smithco) warrants your 2016 or newer Smithco Commercial Product (“Product”) purchased after October 1, 2016 to be free from defects in materials or workmanship for the period of time listed below. Where a warrantable condition exists, Smithco will repair the Product at no cost to you including diagnosis, labor (at the Smithco standard labor rate, subject to the Smithco flat rate schedule), and parts.

Warranty Duration is:

- (1) Two years, 1500 operational hours* from the date of delivery to the original purchaser or Five years from the date of original manufacturer of the product, whichever occurs first. (*Products equipped with hour meter).
- (2) Products used in rental situations are covered for 90 days from date of delivery to original user/renter.

Owner Responsibilities:

As the Product owner, you are responsible for required maintenance and adjustments stated in your Owner’s Manual. Failure to perform required maintenance and adjustments can be grounds for disallowing a warranty claim. **You are particularly responsible to train all present and future operators of this product on the safe operation of this product at your location.**

Instructions for Obtaining Warranty Service:

You are responsible for notifying the Authorized Smithco Products Distributor from whom you purchased the Product as soon as you believe a warrantable condition exists and not later than 30 days from discovery of the condition.

If you need help locating an Authorized Smithco Distributor, or if you have questions regarding your warranty rights or responsibilities, you may contact us at:

Smithco Product Support Department
200 West Poplar Ave.
Cameron, Wisconsin 54822
Telephone: 800-891-9435 E-Mail: ProductSupport@Smithco.com

Maintenance Parts:

Parts scheduled for replacement as required maintenance (“Maintenance Parts”), are warranted for the period of time up to the scheduled replacement time for that part.

Items/Conditions Not Covered:

Not all product failures or malfunctions that occur during the warranty period are defects in materials or workmanship. The items/conditions listed below are not covered by this warranty:



Product failures which result from the use of non-Smithco replacement parts, or from installation and use of add-on, modified, or unapproved accessories are not covered.



Product failures which result from failure to perform required maintenance and/or adjustments are not covered.



Product failures that result from operating the Product in an abusive, negligent or reckless manner are not covered.



This warranty does not apply to parts subject to consumption through use, unless found to be defective. Examples of parts which are consumed, or used up, during normal Product operation include, but are not limited to: blades, tines, teeth, scarifiers, rakes, plates, wear plates, castor wheels, tires, batteries, filters, belts, nozzles, etc.



This warranty does not apply to failures caused by outside influence. Items considered to be outside influence include, but are not limited to, weather, storage practices, contamination, use of unapproved coolants, lubricants, additives, or chemicals, etc.



This warranty does not apply to normal “wear and tear” items. Normal “Wear and Tear” includes, but is not limited to, damage to seats due to wear or abrasion, worn painted surfaces, scratched decals or windows, etc.



Smithco may require the return of failed parts or components in order to determine the validity of any warranty claim.



Smithco will not be obligated to replace components of other manufacturers if inspection by the original component manufacturer indicates that failure was due to normal wear and tear, expected consumption through use or improper care or service.

Other Legal Disclaimers:

The above remedy for product defects through repair or replacement by an authorized Smithco distributor or dealer is the purchaser’s sole remedy for any defect. This warranty gives you specific legal rights, and you may also have other rights which vary from state to state.

THERE ARE NO OTHER EXPRESS WARRANTIES OTHER THAN THOSE SET FORTH ABOVE. ALL IMPLIED WARRANTIES OF MERCHANTABILITY AND FITNESS FOR USE ARE LIMITED TO THE DURATION OF THE LIMITED WARRANTIES CONTAINED HEREIN.

Some states may not allow limitations on how long an implied warranty lasts, so the above limitation may not apply to you.

THE SMITHCO COMPANY IS NOT LIABLE FOR INDIRECT, INCIDENTAL OR CONSEQUENTIAL DAMAGES IN CONNECTION WITH THE USE OF THE PRODUCT, INCLUDING ANY COST OR EXPENSE OF PROVIDING A SUBSTITUTE PRODUCT OR SERVICE DURING PERIODS OF MALFUNCTION OR NON-USE.

Some states may not allow the exclusion of indirect, incidental or consequential damages, so the above exclusion may not apply to you.

Smithco neither assumes, nor authorizes any person to assume for it, any other liability in connection with the sale or use of this product.

