

Parts & Service



**Spray Star 3180**  
**Gas Model 30-000-D**  
**TeeJet Spray System**  
**SN: 300G500**

**January 2019**

**Product Support:**

**Hwy 55 & Poplar Ave; Cameron WI 54822**

**1-800-891-9435 [productsupport@smithco.com](mailto:productsupport@smithco.com)**

# CONTENTS

Introduction

## Introduction.....1-3

Introduction.....	1
General Safe Practices.....	2
Specifications .....	3
Optional Spray Equipment.....	3

Service

## Service.....4-11

Maintenance.....	4-6
Wheel Creep.....	6
Adjustments.....	7-8
Service Chart.....	9-10
Storage.....	11

Diagrams

## Diagrams .....12-15

Wiring Diagram.....	12-13
Hydraulic Diagram.....	14-15

Parts

## Parts.....16-55

Body & Frame .....	16-17
Nose Cone .....	18-21
Orbitrol Drawing.....	22
Fuel Tank .....	23
Foot Pedal Linkage.....	24-25
Spray Boss Linkage.....	26-27
Front Axle .....	28-29
Oil Tank.....	30-31
Seat Panel.....	32-33
Engine .....	34-35
Pumps .....	36-37
Cooler and Exhaust.....	38-39
Rear Wheel Drive.....	40-41
Spray Tank.....	42-43
Turbo Quad Agitator .....	44
16-998 Hypro® Pump .....	45
15-301 Orbitor .....	46-47
76-197 Eaton Gear Pump.....	48
30-101 Eaton Motor.....	49
30-102 Hydrostatic Pump.....	50-53
30-099 Auburn Power Wheel® .....	54-55

Accessories

## Accessories .....56-110

Plumbing 3182 System .....	56-57
Plumbing 3184 System.....	58-59
Plumbing 3185/3186/3187/3188 System.....	60-61
DynaJet® Rear Module Mount .....	62
Wiring TeeJet® 744A .....	63
Wiring TeeJet® Radion .....	64
Wiring TeeJet® Aeros .....	65
Wiring TeeJet® DynaJet .....	66
16-524 Motorized Control Valve .....	67
20-685 Regulator Valve .....	68
15-743 Manifold Ball valve .....	69
15-737/14-628 Flanged Strainer.....	70
14-801 Agitation Strainer.....	71
17-580 20' HD Boom .....	72-75
17-580 20' HD Boom Plumbing .....	76
17-580 20' Heavy Duty Boom DynaJet Plumbing .....	77
17-585 18' Heavy Duty Boom.....	78-81
17-585 18' HD Plumbing .....	82
17-585 18' HD Boom DynaJet Plumbing.....	73
QJS Nozzle Assembly .....	84
QJS Bottom Mounted Nozzle Assembly.....	85
Nozzle Assembly .....	86-87
30-010 Electric Hose Reel .....	88-90
30-009 Hose Reel .....	91
Hose Reel Installation.....	92-93
Hose Reel Adjustments .....	93
30-004 Foam Marker Installation.....	94-99
14-291 Foam Marker Parts List.....	100-102
14-515 Water Meter Kit (Gallons).....	103
15-618 Water Meter Kit (Liters) .....	103
20-758 Fresh Water Tank - Front Mount.....	104
30-006 Fresh Water Tank - Rear Mount .....	105
30-007 Chemical Clean-load System.....	106-107
15-620 Chemical Clean-load® Eductor .....	108-109
15-835 Tank Rinsing System.....	110

Reference

## Reference ..... 111-112

Decal List.....	111
Quick Reference Replacement Parts .....	112
Warranty.....	

Thank you for purchasing a **Smithco** product.

Read this manual and all other manuals pertaining to the Spray Star 3180 carefully as they contain safety, operating, assembly and maintenance instructions. Failure to do so could result in personal injury or equipment damage.

Keep manuals in a safe place after operator and maintenance personnel have read them. Right and left sides are from the operator's seat, facing forward.

 **WARNING:**

**Engine exhaust and some of its constituents are known to the State of California to cause cancer, birth defects, and other reproductive harm.**

**For more information visit**  
**[www.P65Warnings.ca.gov](http://www.P65Warnings.ca.gov)**

**WARNING**

*Failure to follow cautious operating practices can result in serious injury to the operator or other persons. The owner must understand these instructions, and must allow only trained persons who understand these instructions to operate this vehicle.*

All **Smithco** machines have a Serial Number and Model Number. Both numbers are needed when ordering parts. Refer to engine manual for placement of engine serial number.

For product and accessory information, help finding a dealer, or to register your product please contact us at [www.Smithco.com](http://www.Smithco.com).

Information needed when ordering replacement parts:

1. Model Number of machine
2. Serial Number of machine
3. Name and Part Number of part
4. Quantity of parts

For easy access record your Serial and Model numbers here.

<b>SMITHCO</b> WAYNE, PENNSYLVANIA 19087 USA 610-688-4009 Fax 610-688-6069			
SERIAL NO.	kW/hp	DATE OF MFG.	
<input type="text"/>	<input type="text"/>	<input type="text"/>	
MODEL NO.	lb/kg Empty	lb/kg Full	
<input type="text"/>	<input type="text"/>	<input type="text"/>	

**SMITHCO CUSTOMER SERVICE 1-800-891-9435**

## SAFE PRACTICES

1. It is your responsibility to read this manual and all publications associated with this machine.
2. Never allow anyone to operate or service the machine or its optional equipment without proper training and instructions. Never allow minors to operate any equipment.
3. Learn the proper use of the machine, the location and purpose of all the controls and gauges before you operate the equipment. Working with unfamiliar equipment can lead to accidents.
4. Wear all the necessary protective clothing and personal safety devices to protect your head, eyes, ears, hands and feet. Operate the machine only in daylight or in good artificial light.
5. Inspect the area where the equipment will be used. Pick up all debris you can find before operating. Beware of overhead obstructions and underground obstacles. Stay alert for hidden hazards.
6. Never operate equipment that is not in perfect working order or without decals, guards, shields, or other protective devices in place.
7. Never disconnect or bypass any switch.
8. Carbon monoxide in the exhaust fumes can be fatal when inhaled, never operate a machine without proper ventilation.
9. Fuel is highly flammable, handle with care.
10. Keep engine clean. Allow the engine to cool before storing and always remove the ignition key.
11. Disengage all drives and set park brake before starting the engine.
12. Never use your hands to search for oil leaks. Hydraulic fluid under pressure can penetrate the skin and cause serious injury.
13. This machine demands your attention. To prevent loss of control or tipping of the vehicle:
  - A. Use extra caution in backing up the vehicle. Ensure area is clear.
  - B. Do not stop or start suddenly on any slope.
  - C. Reduce speed on slopes and in sharp turns. Use caution when changing directions on slopes.
  - D. Stay alert for holes in the terrain and other hidden hazards.
14. Before leaving operator's position:
  - A. Disengage all drives.
  - B. Set park brake.
  - C. Shut engine off and remove the ignition key.
  - D. If engine has to run to perform any maintenance keep hands, feet, clothing and all other parts of body away from moving parts.
15. Keep hands, feet and clothing away from moving parts. Wait for all movement to stop before you clean, adjust or service the machine.
16. Keep the area of operation clear of all bystanders.
17. Stop engine before making repairs/adjustments or checking/adding oil to the crankcase.
18. Use parts and materials supplied by **Smithco** only. Do not modify any function or part.
19. Use caution when booms are down as they extend out beyond the center line of the machine.
20. The tank is a confined space, take precaution.

***These machines are intended for professional maintenance on golf courses, sports turf, and any other area maintained turf and related trails, paths and lots. No guaranty as to the suitability for any task is expressed or implied.***

# SPECIFICATIONS SPRAY STAR 3180

## WEIGHTS AND DIMENSIONS

Length	128" (3.3m)
Width	72" (1.8m)
Width w/ Booms Open	20' - 260" (6.6m) 18' - 240" (6.1m)
Height w/ ROPS	84" (2.1m)
Height w/ Booms Folded	20' - 136" (3.5m) 18' - 110"(2.8m)
Wheel Base	68" (1.7m)
Weight Empty	2340 lbs (1061 kg)
Weight Full	4950 lbs (2245 kg)

## SOUND LEVEL (DBA)

At ear level	88 dBA
At 30 ft. (9.14 m)	77 dBA

## ENGINE

Make	Kubota
Model#	WG1605
Code / Spec#	G-E3-KEA-3
Rated Horsepower	57 hp (42.5 kW) @3600RPM
Fuel (EMISSIONS)	Unleaded 87 Octane Gasoline Minimum
Cooling System	Liquid Cooled
Lubrication System	Full Pressure
Alternator	40 Amp

## WHEELS & TIRE

Front: Two 22 x 11.00 x 10 Turf; 20 psi (1.4 bar)  
Rear: Two 29 x 14.00 x 15 Multi-Trac; 30 psi (2.0 bar)

## SPEED

Infinitely Variable 0-10 m.p.h. (0-18 kph)

## BATTERY

	Automotive type 24F - 12 volt
BCI Group	Size 24
Cold Cranking Amps	900 minimum
Ground Terminal Polarity	Negative (-)
Maximum Length	10.25" (26 cm)
Maximum Width	6.88" (17 cm)
Maximum Height	10" (25 cm)

## FLUID CAPACITY

Crankcase Oil	See Engine Manual
Fuel	20 gallon (75.7 liters)
Hydraulic Fluid	10 gallon (37.8 liters)
Grade of Hydraulic Fluid	SAE 10W-40 API Service SL or higher Motor Oil

## OPTIONAL EQUIPMENT

15-618	Water Meter Kit (liters)	30-009	Manual Hose Reel
17-585	18' HD Super Boom	30-010	Electric Hose Reel
17-580	20' HD Super Boom	30-004	Foam Marker
30-006	Fresh Water Tank	15-835	Tank Rinse System
30-007	Chemical Cleanload Safe Fill	15-850	Sunshade Canopy
31-004	All Weather Top	14-515	Water Meter Kit (Gal)
17-590	Sonar Boom for HD Booms	30-215	Electric Wash Tank
17-622	Drift Reduction Boom Shield		

# MAINTENANCE

## ⚠ CAUTION

Before servicing or making adjustments to machine, stop engine and remove key from ignition.

## ⚠ IMPORTANT

Use all procedures and parts prescribed by the manufacturer's. Read the engine manual before operation.

### LUBRICATION

Use No. 2 General purpose lithium base grease and lubricate every 100 hours. The Spray Star 3180 has 7 grease fittings.

- A. One on the rod end of hydraulic cylinder.
- B. One on each the right and left spindles.
- C. One on the center front pivot.
- D. One on the idler arm.
- E. One on each of the pedal relays.

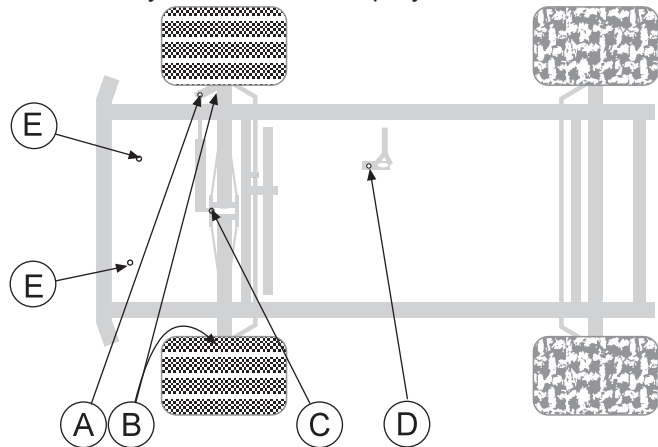

### ELECTRICAL CONNECTIONS

Use dielectric grease on all electrical connections.

### AIR CLEANER ON ENGINE

Since the air cleaner on this engine is a dry type, never apply oil to it.

1. Open evacuator valve (see engine manual) once a week to remove large particles of dust and dirt.
2. Wipe the inside of the air cleaner with a cloth if it gets wet or dirty.
3. Avoid touching the element except when cleaning.
4. When dust adheres to the element, gently tap element on flat surface.
5. When carbon or oil adheres to the element clean according to engine manual.
6. Replace the element every year or every 6 months.
7. **IMPORTANT** - Make sure wing bolt for the element is tight enough. If it is loose, dust and dirt may be sucked in, wearing down the cylinder liner and piston ring, resulting in poor power output.

## ⚠ IMPORTANT

Do not use petroleum solvents, e.g., kerosene, which will cause cartridge to deteriorate. Do not use pressurized air to clean cartridge. Pressurized air can damage cartridge.

## ENGINE OIL

Change and add oil according to chart below based on air temperature at the time of operation. Do not overfill. Use a high quality detergent oil classified "For Service use API classification SL or higher" oil. Use no special additives with recommended oils. Do not mix oil with gasoline.

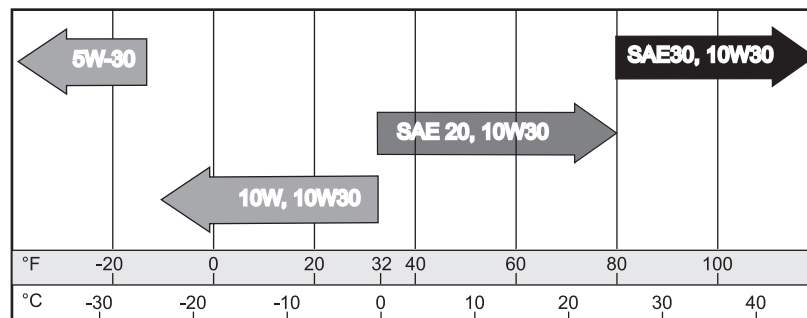

*Starting Temperature Range Anticipated Before Next Oil Change*

## HYDRAULIC OIL

1. Use SAE 10W-40 API Service SJ or higher motor oil.
2. For proper warranty, change oil the first 50 hours and then every 200 hours or annually, which ever is first.
3. Oil level should be 2-2½" (5-6.4cm) from top of the tank when fluid is cold. Do not overfill.
4. After changing oil, run the machine for a few minutes. Check oil level and for leaks.
5. Always use extreme caution when filling hydraulic oil tank or checking level to keep system free of contaminants. Check and service more frequently when operating in extremely cold, hot or dusty conditions.
6. If the natural color of the fluid has become black or smells burnt, it is possible that an overheating problem exists.
7. If fluid becomes milky, water contamination may be a problem.
8. If either of the above conditions happen, change oil immediately after fluid is cool and find the cause. Take fluid level readings when the system is cold.
9. In extreme temperatures you can use straight weight oil. We recommend SAE 30W API Service SG when hot (above 90°F (33°C)) and SAE 10W API Service SJ or higher when cold (below 32°F (0°C) ambient temperature. Use either motor oil or hydraulic oil, but do not mix.
10. Oil being added to the system must be the same as what is already in the tank. Mark the tank fill area as to which type you put in.

## TIRE PRESSURE

Caution must be used when inflating a low tire to recommended pressure. Over inflating can cause tires to explode. Front tires should be 20 psi (1.4bar) and rear tires should be 30 psi (2.0bar). Improper inflation will reduce tire life considerably.

# MAINTENANCE

## BATTERY

Batteries normally produce explosive gases which can cause personal injury. Do not allow flames, sparks or any ignited object to come near the battery. When charging or working near battery, always shield your eyes and always provide proper ventilation.

Battery cable should be disconnected before using "Fast Charge".

Charge battery at 15 amps for 10 minutes or 7 amps for 30 minutes. Do not exceed the recommended charging rate. If electrolyte starts boiling over, decrease charging.

Always remove grounded (-) battery clamp first and replace it last. Avoid hazards by:

1. Filling batteries in well-ventilated areas.
2. Wear eye protection and rubber gloves.
3. Avoid breathing fumes when electrolyte is added.
4. Avoid spilling or dripping electrolyte.

### ⚠ WARNING

**Battery Electrolyte is an acidic solution and should be handled with care. If electrolyte is splashed on any part of your body, flush all contact areas immediately with liberal amounts of water. Get medical attention immediately.**

### ⚠ WARNING

**Use of booster battery and jumper cables. Particular care should be used when connecting a booster battery. Use proper polarity in order to prevent sparks.**

### TO JUMP START (NEGATIVE GROUNDED BATTERY):

1. Shield eyes.
2. Connect ends of one cable to positive (+) terminals of each battery, first (A) then (B).
3. Connect one end of other cable to negative (-) terminal of "good" battery (C).
4. Connect other end of cable (D) to engine block on unit being started (NOT to negative (-) terminal of battery)

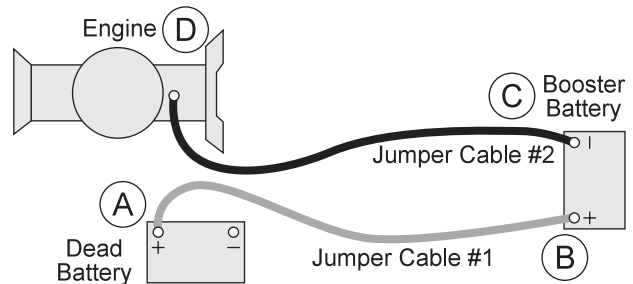

To prevent damage to other electrical components on unit being started, make certain that engine is at idle speed before disconnecting jumper cables.

# WHEEL CREEP

## WHEEL CREEP

"Creep" is when the engine is running and hydrostatic transmission is in neutral, but due to inadequate alignment, wheels still move. Do the following procedure to stop this motion.

1. Lift up and support machine so rear wheels are off the ground and can turn freely.
2. In the engine compartment, the hydrostatic pump is on the right side. The shift arm (D) is on top of the pump. The idler arm (B) has a bearing that rides in the vee of the shift arm. Loosen bolt (A).
3. With engine running, move bearing (B) so it centers on the shift arm (D) and 'wheel creep' stops.
4. Tighten all fasteners and test by using foot pedal linkage to see that 'creep' is removed.
5. Turn engine off and lower machine.

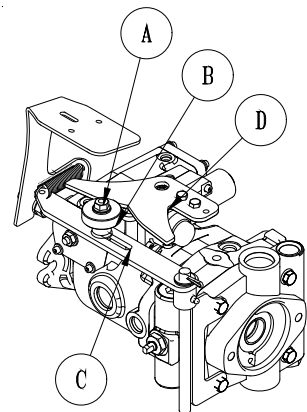

## SPRAY PUMP WITH BELT

Located to the right of the engine. The belt should have approximately 1/2" (13mm) of deflection in the center of the top strand.

## SAFETY INTERLOCK SWITCH

To adjust the interlock switch on the back hydrostatic pump loosen the set screw on the front half of the switch, with the ignition switch OFF. With a continuity tester connected across the switch, it should light with the shift arm centered. Move the shift arm to the right or left and the light should go off. By turning the back half of the switch clockwise it will reduce the amount of travel on the shift arm that is required for the light to remain on. The light must be on ONLY with the shift arm centered.

## MASTER BOOM SWITCH (FOOT SWITCH)

The master boom switch(B), located on the left floorboard, is used to override the master switch (A) on the computer console of the spray systems. By pushing down on the floor master boom switch (B) it will turn on/off the booms. *For the TeeJet System* the master switch(A) on the computer **must be on** for the master boom control switch(B) on the floor to work.

## GROUND SPEED CONTROL (FOOT SWITCH)

The ground speed control(C) is located on the left floorboard and is used to lock forward speed. The ground speed control does not work the same as an automotive type cruise.

## TO ENGAGE:

1. Flip rocker switch(D)'On' (green light).
2. Obtain desired speed with forward foot pedal.
3. Step on foot switch(C) to lock speed.
4. Push foot switch(C) again to disengage.

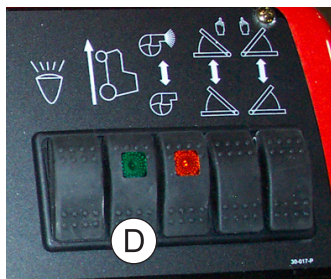
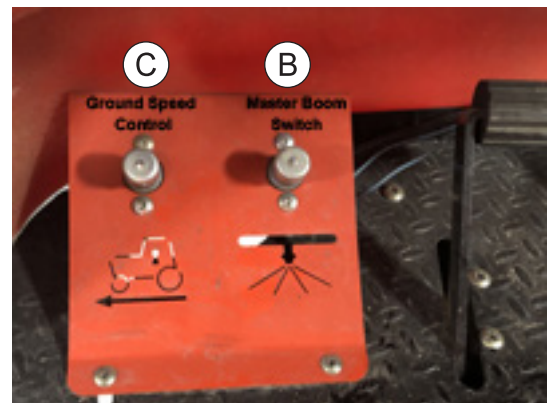

# ADJUSTMENTS

## SPRAY BOSS CONTROL

Engages and disengages speed boss. Forward is engage and all the way back is disengage. When the lever is engaged it sets a stop for the accelerator. The accelerator pedal must be used to maintain this speed. To adjust speed use the knob on the end of the lever, counter clockwise increases speed and clockwise decreases speed. Disengage the lever and you will have full accelerator pedal range.



## BRAKE RELEASE

Run machine at half-throttle minimum, prior to operating traction pedal. This will ensure proper brake release.

## TOWING

Brake must be disengaged for towing. The brake disengage cover is located at the center of the Auburn wheel drive on the rear wheels. To disengage the brake, remove the disengage cover and assemble the disengage cover with the dimple center protruding inward. This will release the brake shaft. **Road speeds must not exceed 20 MPH.** Re-assemble the disengage cover back to its original way when done towing.

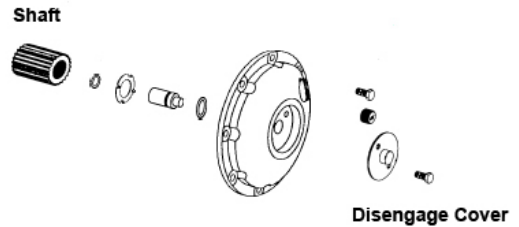

**⚠ WARNING**

**Machine is in free wheel mode when towing.  
Machine has no braking capabilities when being towed.**

## TANK AGITATION

The valve to turn on and off the tank agitation is located on the front of the seat panel, drivers right hand side. Rotate valve handle down to shut off and rotate back up to turn on.

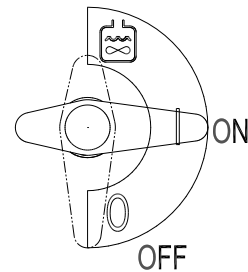



# SERVICE CHART

Item	Maintenance Procedure
After the first 8 operating hours	Torque the wheel lug nuts. (64-74 ft/lb (87-100 Nm)) Change the engine oil filter.
Before each use daily	Check the engine oil level. Clean area around muffler and controls. Check the hydraulic fluid level. Check the tire pressure. Check condition of hydraulic hoses and fittings. Check for oil or water leaks. Proper function of glow lamp timer.
After the first 50 hours	Change Hydraulic Oil Filter. Change Engine oil and filter.
Every 100 hours	Clean or change air filter. <sup>1&amp;2</sup> Clean fuel filter element. <sup>1</sup> Lubricate machine. Check the battery fluid level and cable connections.. Check fan belt tension and damage.
Every 200 hours	Check radiator hoses and clamp bands. Change engine oil. <sup>1</sup> Check idle speed. Replace oil filter cartridge. <sup>1</sup> Change hydraulic oil filter. <sup>1</sup> Check air intake line. <sup>1</sup> Torque the wheel lug nuts. (64-74 ft/lb (87-100 Nm))
Every 500 hours or yearly	Clean Water Jacket and radiator interior. Replace fan belt.
Every 800 hours	Check valve clearance.
Every 1500 hours	Check injection nozzle pressure.
Every 3000 hours	Check turbo charger. Check injection pump. Check injection timing.
Every 2 years	Change radiator coolant (L.L.C.) Replace radiator hoses and clamp bands. Replace fuel hoses and clamps. Replace intake air lines.

<sup>1</sup> In dusty conditions or when airborne debris is present, clean more often.

<sup>2</sup> Replace after every 6 times of cleaning

**⚠ IMPORTANT**

**To prevent damage from freezing, pour window washer fluid into spray systems tank and operate pump to circulate mix through gun and hose back to tank. Open boom control to circulate through rest of spray system.**

1. Clean the exterior surfaces of the engine.
2. Change the oil and filter while the engine is still warm from operation.
3. Drain coolant from the radiator. Open cock at the bottom of the radiator, and remove the pressure cap to drain water completely. Leave the cock open. Hang a not written "No Water" on the pressure cap. Since water freezes when temperature drops below 0°C (32° F) it is important that no water is left in the machine.
4. Remove battery from the engine, adjust the electrolyte level, and recharge it. Store battery in a dry dark place.
5. Store machine in a clean, dry place.

**EXTENDED STORAGE**

1. Check for any damaged parts or missing decals. Replace as needed.
2. Drain crankcase completely and refill with recommended engine oil or equivalent.
3. Lubricate all grease points.
4. Check coolant protection and level.
5. Clean exterior surface of engine.
6. Seal all openings in engine and accessories with non-hygroscopic material. Mask off all areas to be used for electrical contact.
7. Tape all openings and make sure all surfaces are dry. Then spray all taped openings, all engine accessories including ignition wiring, and all exterior surfaces of engine with Insulation Compound.
8. Disconnect, remove and clean battery. Check electrolyte level. Charge the battery and store in a cool dry place (NOT directly on cement).
9. Put blocks or stands under the machine to take weight off tires.

**AFTER STORAGE**

1. Check for any damaged parts or missing decals. Replace as needed.
2. Lubricate all grease points.
3. Clean exterior surface of engine.
4. Remove all tape and obstructions from exterior engine surfaces.
5. Charge and replace battery.
6. Check tire pressure.
7. Remove blocks or supports from under the machine.
8. Check engine oil level and coolant level and lubricate all grease points.
9. Fill fuel tank.
10. Check belt tension.
11. Run engine approximately 5 minutes before putting the engine under load.

# WIRING DIAGRAM

## Color Code Chart

Bl	Blue
Br	Brown
Y	Yellow
G	Green
O	Orange
R	Red
B	Black
P	Purple
W	White

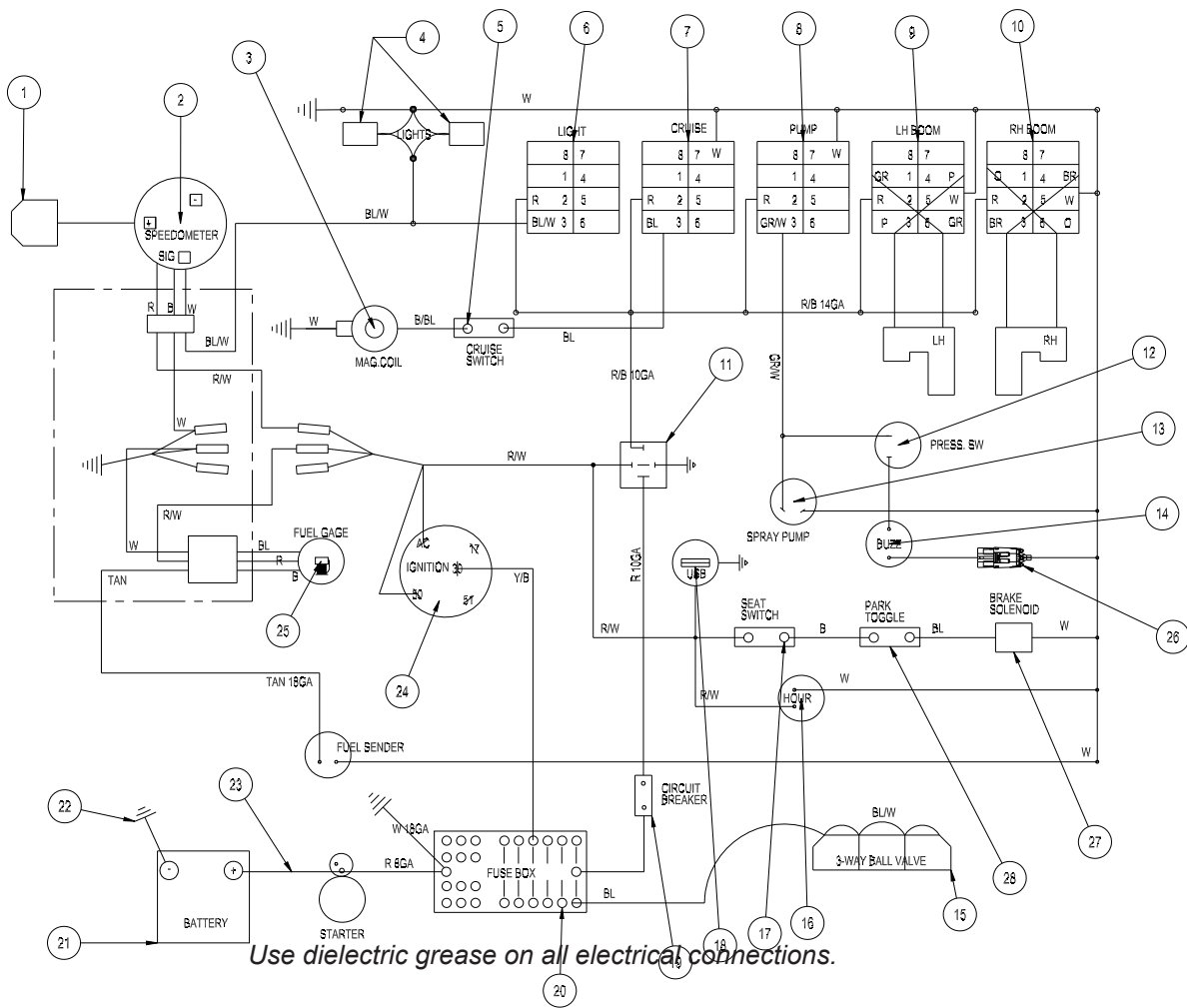

# WIRING DIAGRAM

REF#	PART#	DESCRIPTION	QUANTITY
1	20-730-01	GPS Antenna (part of speedometer)	1
2	30-356	GPS Speedometer	1
3	33-084	Magnetic Coil	1
4	32-014	Lights	2
5	33-509	Cruise Foot Switch	1
6	15-725	Mount Panel End	1
	15-727	Rocker, No Light	1
	15-782	Non-Lighted Switch	1
7	15-729	Mount Panel Middle	1
	15-726	Lighted Switch	1
	15-732	Rocker, Green	1
8	15-729	Mount Panel Middle	1
	15-726	Lighted Switch	1
	15-731	Rocker, Amber	1
9	15-729	Mount Panel Middle	1
	15-727	Rocker, No Light	1
	15-728	Centering Switch, Momentary, On-Off-On	1
10	15-725	Mount Panel End	1
	15-727	Rocker, No Light	1
	15-728	Centering Switch, Momentary, On-Off-On	1
11	30-042-06	Relay	1
12	33-480	Pressure Switch	1
13	16-998	Hypro Pump	1
14	77-207	Buzzer	1
15	18-372	Manifold Ball Valve	1
16	12-804	Hour Meter	1
17	14-292	Seat Switch	1
18	32-576	USB Power Charger	1
19	20-693	Circuit Breaker, 50AMP	1
	8977	Circuit Breaker Boot	1
20	32-573	Fuse Block	1
21	33-216	Battery	1
22	48-147	Ground Battery Cable	1
23	75-518	Battery Cable	1
24	13-488	Ignition Switch	1
25	32-649	LED Fuel Gage w/ Terminals	1
26	9016	Weather Pack	1
	9017	Weather Pack Terminal	2
	9018	Seal	2
27	30-194	Brake Manifold with Relief Valve	1
28	12-003	Park Brake Toggle Switch	1
	30-143	Toggle Switch Guard	1
	30-338	Main Wire Harness	1
	30-344	Engine Wire Harness	1
	30-345	Fuel Pressure Manifold Harness	1

# HYDRAULIC DIAGRAM

Diagrams

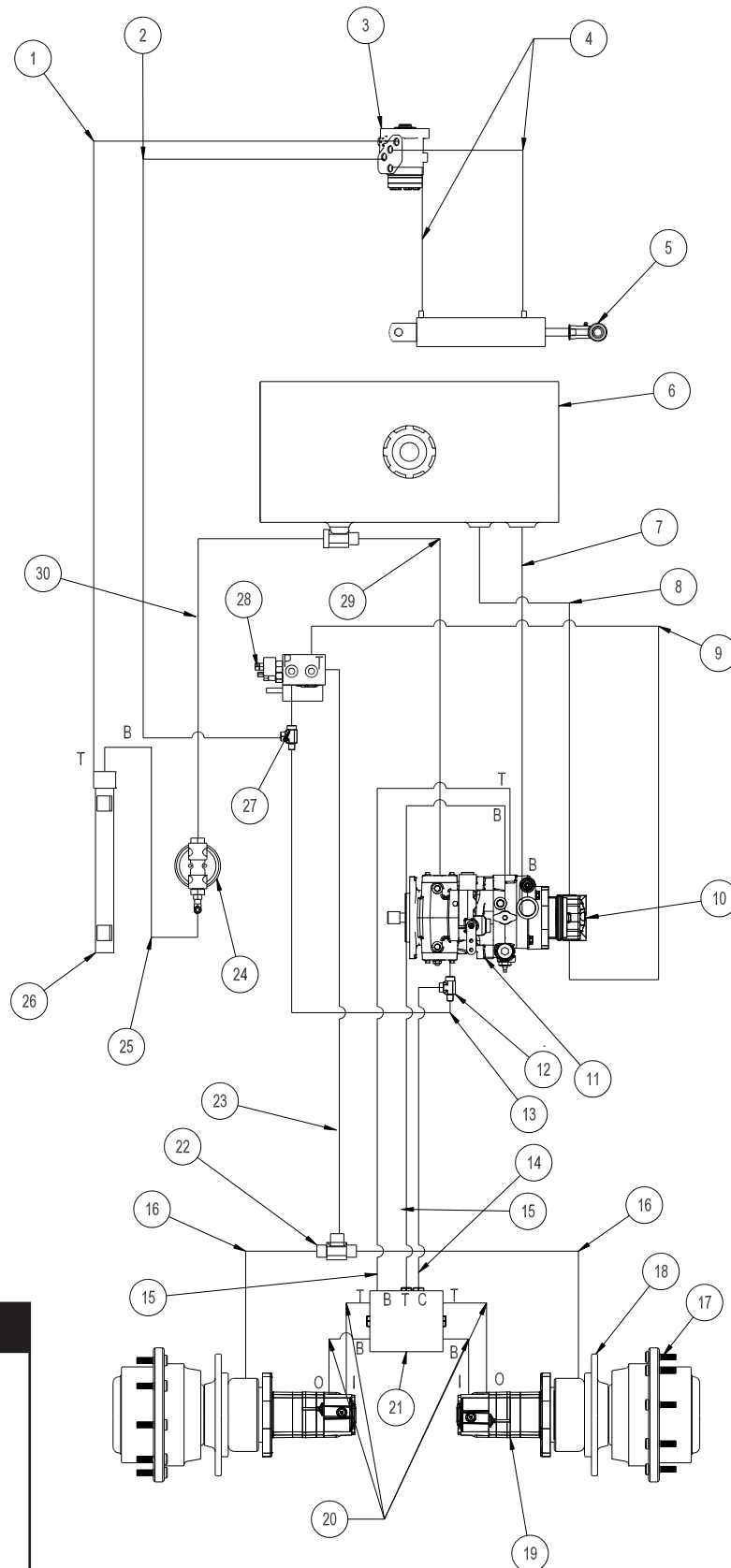

## Letter Code Chart

C	Center
I	Inside
O	Outside
T	Top
B	Bottom

## HYDRAULIC DIAGRAM PARTS LIST

REF#	PART#	DESCRIPTION	QUANTITY
1	30-156	Hydraulic Hose	1
2	30-091	Hydraulic Hose	1
3	15-301	Orbitrol	1
4	30-094	Hydraulic Hose	2
5	15-839	Steering Hydraulic Cylinder	1
	14-531	Seal Kit	1
	18-171	<sup>3</sup> / <sub>8</sub> Seal Loc Adapter	2
6	30-025	Oil Tank	1
	13-747	Filler Breather	1
	13-586-03	Neck	1
7	8833-9	1" Suction Hose	1
	18-222	Hose Clamp	2
8	8833-17	1" Suction Hose	1
	18-222	Hose Clamp	2
9	30-093	Hydraulic Hose	1
10	76-197	Gear Pump	1
11	30-102	Eaton Closed Loop Pump	1
12	18-405	Run Tee	1
13	30-086	Hydraulic Hose	1
14	30-085	Hydraulic Hose	1
15	30-090	Hydraulic Hose	2
16	30-087	Hydraulic Hose	2
17	30-099	Wheel Drive	2
18	30-100	Hydraulic Release Brakes	2
19	30-101	Eaton Wheel Motors	2
20	30-089	Hydraulic Hose	4
21	30-103	Hot Oil Shuttle Manifold	1
22	18-395	Union Tee	1
23	30-088	Hydraulic Hose	1
24	72-146	Oil Filter Assembly	1
	60-334	Replacement Element	1
25	8833-41	1" Suction Hose	1
	18-222	Hose Clamp	2
26	30-105	Oil to Air Heat Exchanger	1
27	18-308	Swivel Tee	1
28	30-194	Brake Manifold w/ Relief	1
	30-104-01	Cartridge Valve	1
	30-104-02	Coil	1
29	8917-17	<sup>5</sup> / <sub>8</sub> " Suction Hose	1
	18-040	Hose Clamp	2
30	8833-28	1" Suction Hose	1
	18-222	Hose Clamp	2

# BODY & FRAME DRAWING

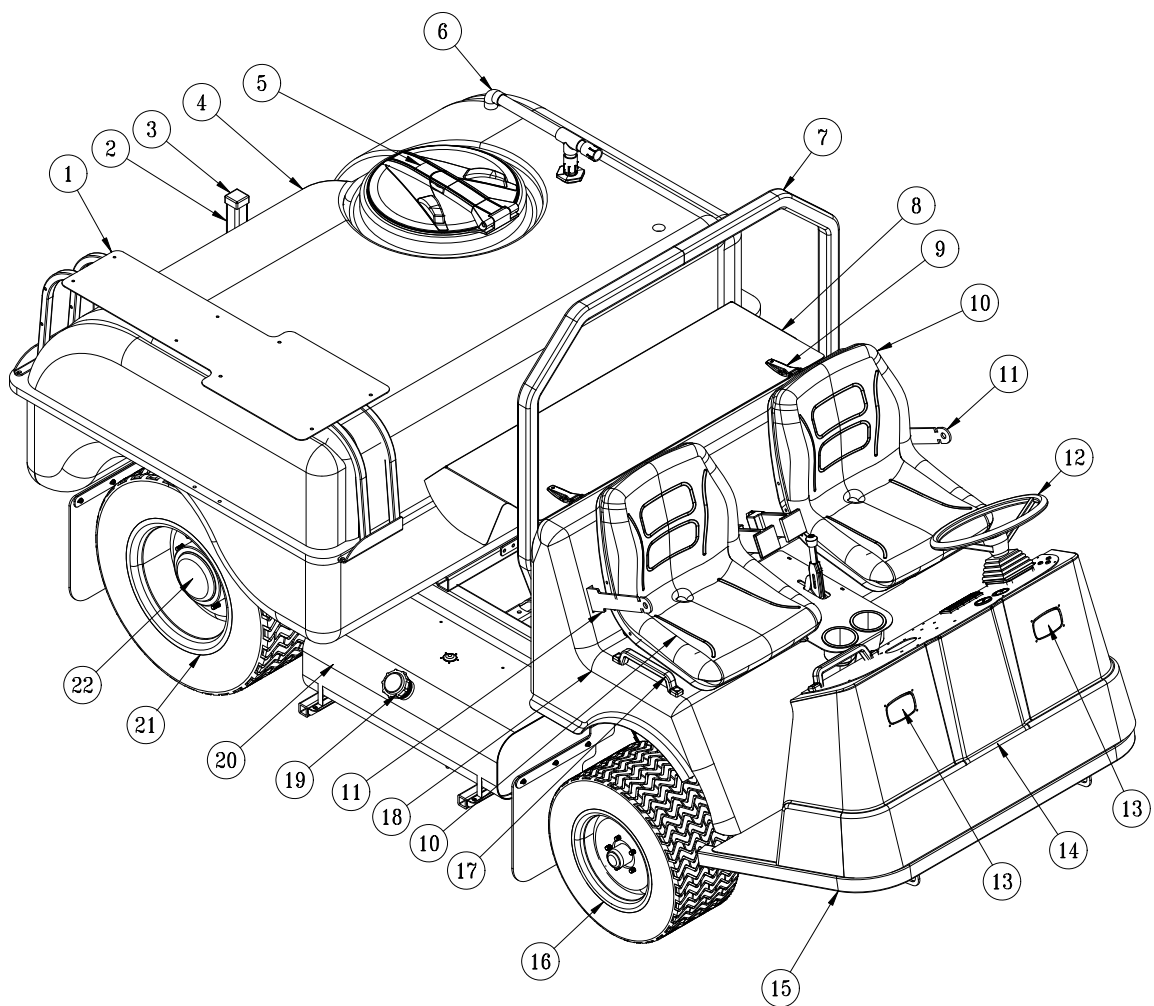

Parts

## BODY & FRAME PARTS LIST

REF#	PART#	DESCRIPTION	QUANTITY
1	30-110	Accessory Mount Bracket	1
	HB-516-18-175	Hex Bolt, <sup>5</sup> / <sub>16</sub> - 18 x 1 <sup>3</sup> / <sub>4</sub>	4
	HW-516	Flat Washer, <sup>5</sup> / <sub>16</sub>	4
	HNFL-516-18	Flange Whiz-loc Nut, <sup>5</sup> / <sub>16</sub> - 18	4
2	17-615	Boom Carrier	2
	HB-12-13-150	Hex Bolt, <sup>1</sup> / <sub>2</sub> - 13 x 1 <sup>1</sup> / <sub>2</sub>	4
	HNFL-12-13	Flange Whiz-loc Nut, <sup>1</sup> / <sub>2</sub> - 13	4
3	16-557	Square Cap	2
4	30-095	318 Gallon Tank (Fiberglass)	1
	25-372	Decal, Smithco 4" Star	1
	30-016	Decal, Spray Star 3180	2
5	16-953	16" Hinged Lid Well	1
	16-953-01	Gasket for Lid	1
	16-169	Strainer Basket	1
6	14-365	Air Gap Filler	1
7	31-063	Roll Bar	1
8	30-308	Engine Cover (Fiberglass)	1
9	27-055	Flush Hinge	2
	HSM 10-32-100	Machine Screw, #10-32-100	12
	HNFL-10-32	Flange Whiz-loc Nut, #10 - 32	12
10	14-294	Seat Kit (includes * items)	2
	*14-292	Seat Switch	2
	*14-800	Seat Rail Set	2
	*HSP-1260-340-250	Seat Spacer	8
11	76-198-03	Seat Belt	2
12	13-718	15" Steering Wheel	1
	13-726	Center Cap	1
	27-077	Decal, Smithco Round	1
13	32-014	Headlight	2
14	31-044	Nose Cone (Fiberglass)	1
15	30-325	Main Frame	1
16	43-124	Turf Tread Tire and Wheel	2
	43-123-01	Tire	2
	43-058-01	Wheel	2
	HNL-12-20	Lug Nut, <sup>1</sup> / <sub>2</sub> - 20	14
17	76-443	Handle	3
18	30-339	Seat Assembly(Fiberglass)	1
19	30-351	Vented Fuel Cap	1
20	32-531	20 Gallon Fuel Tank	1
21	30-048	Tire and Wheel(assembled)	2
	30-048-01	Tire	2
	30-048-02	Wheel	2
	HNL-12-20	Lug Nut, <sup>1</sup> / <sub>2</sub> - 20	14
22	30-099	Auburn Wheel Drive	2

# NOSE CONE DRAWING

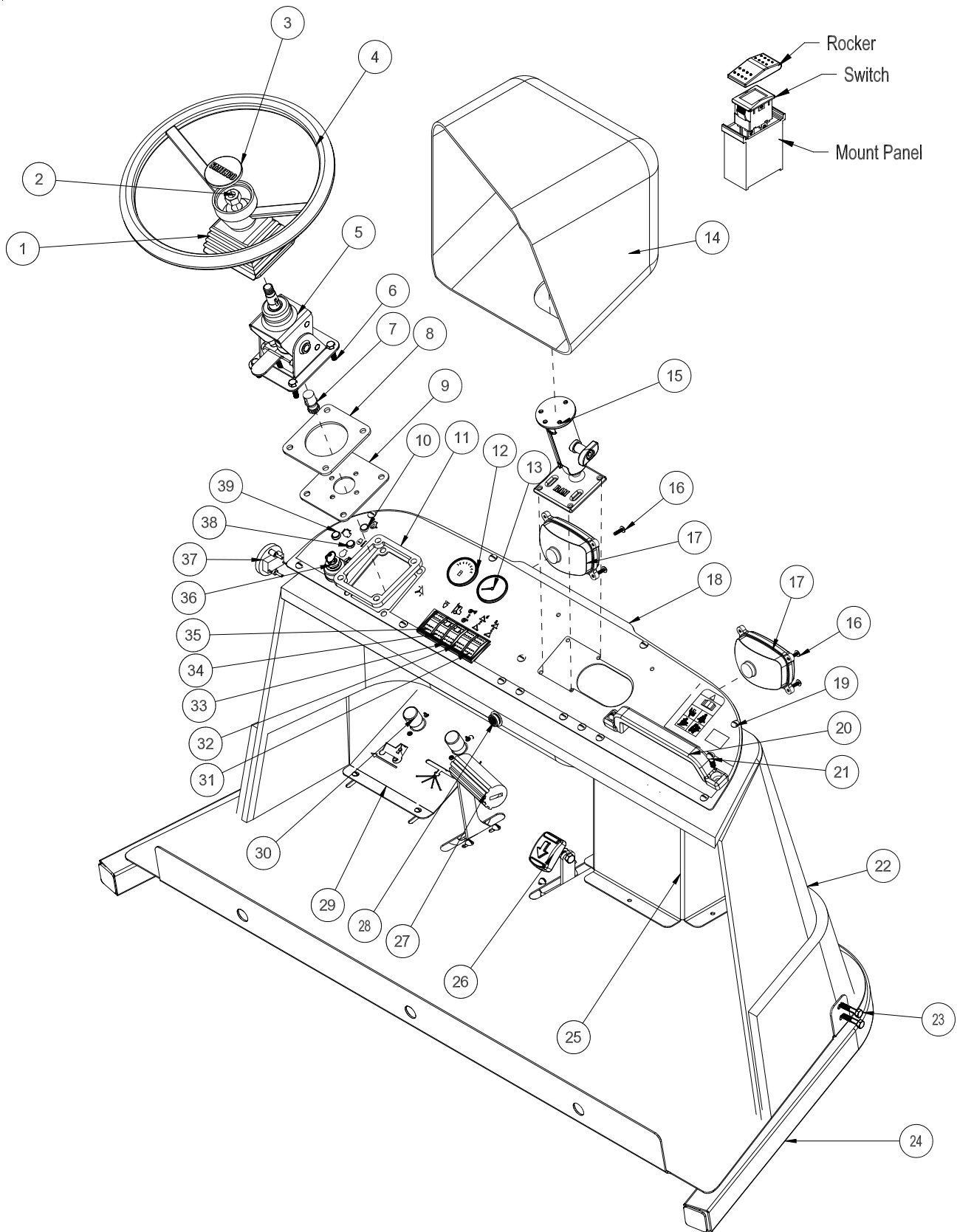

PARTS

# NOSE CONE PARTS LIST

REF#	PART#	DESCRIPTION	QUANTITY
1*	76-364	Square Boot	1
2*	HNJ-58-18	Jam Nut, $\frac{5}{8}$ - 18	1
3	13-726	Center Cap	1
	27-077	Decal, Smithco Round	1
4	13-718	15" Steering Wheel	1
5	76-362	Mini Tilt Steering(includes * items)	1
6	HB-516-18-150	Hex Bolt, $\frac{5}{16}$ - 18 x $1\frac{1}{2}$	4
	HNFL-516-18	Flange Whiz-loc Nut, $\frac{5}{16}$ -18	4
7	48-187	Stub shaft	1
8	15-844	Tilt Steering Spacer	1
9	31-056	Tilt Steering Plate	1
10	50-359	Oil Indicator Light	1
11	31-057	Steering Spacer	1
12	32-649	LED Fuel Gage w/ Terminals	1
13	20-730	GPS Speedometer	1
14	10-638	Spray System Console Cover (fiberglass)	1
15	20-540	Spray System Ram Mount	1
16	HSM-10-32-100	Machine Screw, #10 -32 x 1	8
	HNFL-10-32	Flange Whiz-loc Nut, #10 -32	8
17	32-014	Head Light	2
18	30-342	Dash Panel	1
	30-320	Decal, Dash Panel	1
19	HSM-10-32-100	Machine Screw, #10 -32 x 1	9
	HNFL-10-32	Flange Whiz-loc Nut, #10 -32	9
20	76-443	Black Handle	1
21	HSTP-516-18-100	Phillips Machine Screw, $\frac{5}{16}$ -18 x 1	2
	HNFL-516-18	Flange Whiz-loc Nut, $\frac{5}{16}$ -18	2
22	31-044	Nose Cone (fiberglass)	1
23	HSTP-516-18-150	Phillips Machine Screw, $\frac{5}{16}$ -18 x $1\frac{1}{2}$	7
	HNFL-516-18	Flange Whiz-loc Nut, $\frac{5}{16}$ -18	7
24	30-325	Main Frame	1
25	31-062	Hose Guard	1
26	31-050	Reverse Pedal	1
	45-022	Molded Pedal Pad	1
27	10-163	Forward Foot Pedal	1
	48-066	Pedal Grip	1
28	77-207	Buzzer	1
29	31-049	Button Plate	1
	HB-14-20-075	Hex Bolt, $\frac{1}{4}$ -20 x $\frac{3}{4}$	2
	HNFL-14-20	Flange Whiz-loc Nut, $\frac{1}{4}$ - 20	2
30	33-509	Master Control Switch	2
	HSTP-14-20-075	Machine Screw, $\frac{1}{4}$ - 20 x $\frac{3}{4}$	4
	HNFL-14-20	Flange Whiz-loc Nut, $\frac{1}{4}$ - 20	4

(Continued on next page)

# NOSE CONE DRAWING

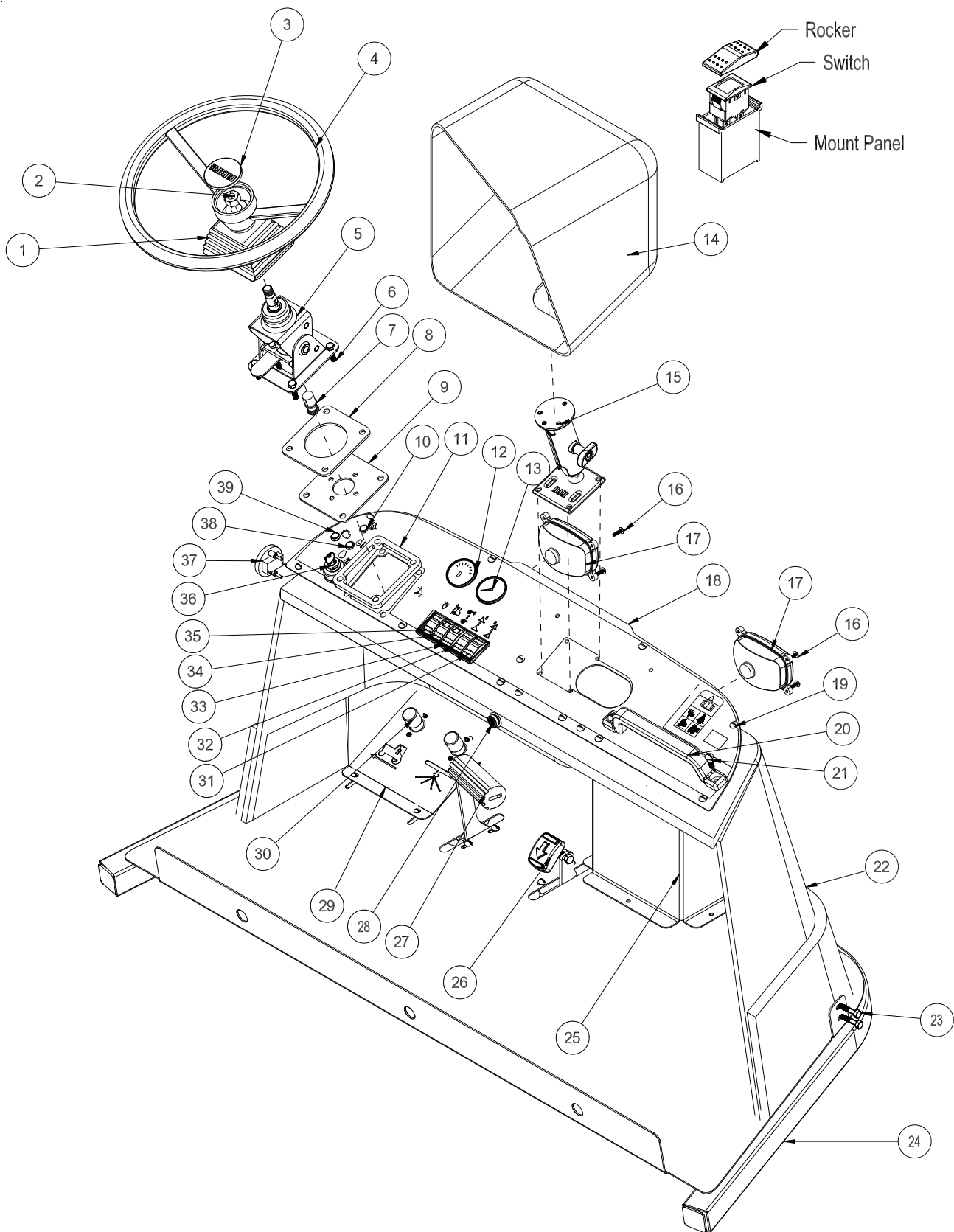

PARTS

## NOSE CONE PARTS LIST

REF#	PART#	DESCRIPTION	QUANTITY
31	RIGHT BOOM		
	15-727	Rocker, No Light	1
	15-729	Mount Panel Middle	1
32	LEFT BOOM		
	15-728	Centering Switch, Momentary On-Off-On	1
	15-725	Mount Panel End	1
33	PUMP		
	15-727	Rocker, No Light	1
	15-726	Lighted Switch	1
34	CRUISE		
	15-729	Mount Panel Middle	1
	15-731	Rocker, Amber	1
35	LIGHTS		
	15-726	Lighted Switch	1
	15-727	Rocker, No Light	1
36	15-782	Non-Lighted Switch	1
	13-488	Ignition	1
	12-804	Hour Meter	1
37	50-359	Temperature Indicator Light	1
38	32-521-03	Engine Indicator Light - Amber	1
39			

# ORBITROL DRAWING

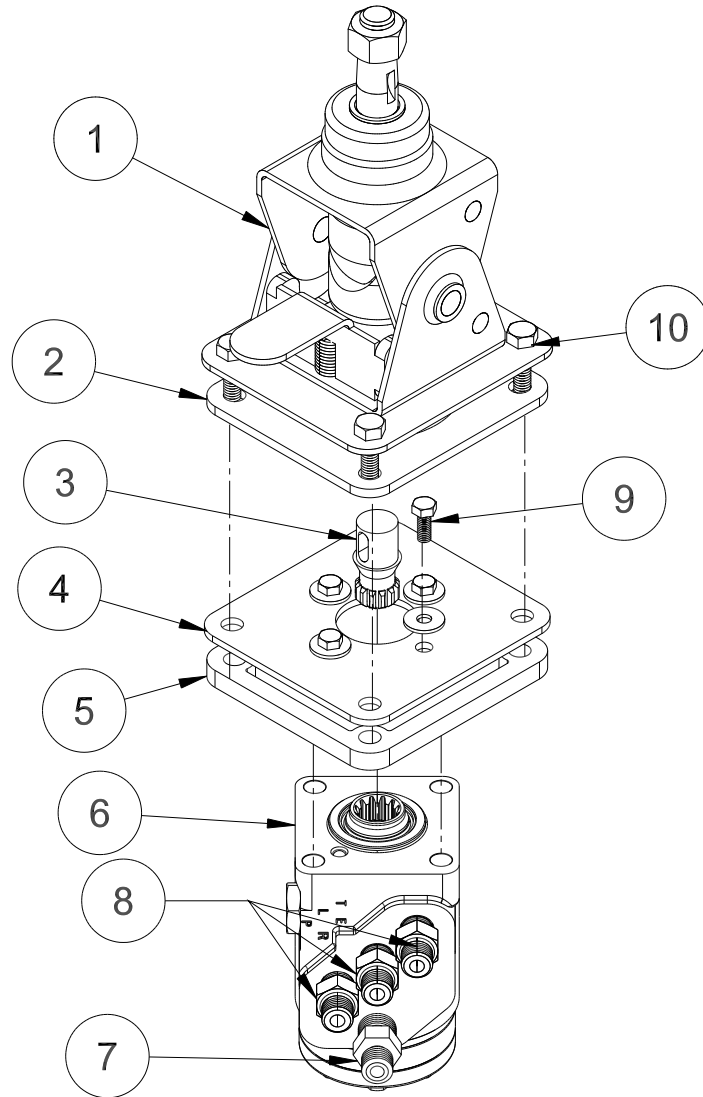

REF#	PART#	DESCRIPTION	QUANTITY
1	76-362	Mini Tilt Steering	1
2	15-844	Tilt Steering Spacer	1
3	48-187	Stub Shaft	1
4	31-056	Tilt Steering Plate	1
5	31-057	Steering Spacer	1
6	15-301	Orbitrol	1
7	18-306	Straight Thread Connector	1
8	7-867	Connector, SAE #6	3
9	HBM-6-1-16	Metric Hex Bolt, M6-1-16	4
	HWLM-6	Metric Lock Washer, M6	4
10	HB-516-18-150	Hex Bolt, $\frac{5}{16}$ - 18 x 1 $\frac{1}{2}$	4
	HNFL-516-18	Flange Whiz-loc Nut, $\frac{5}{16}$ - 18	4

# FUEL TANK DRAWING

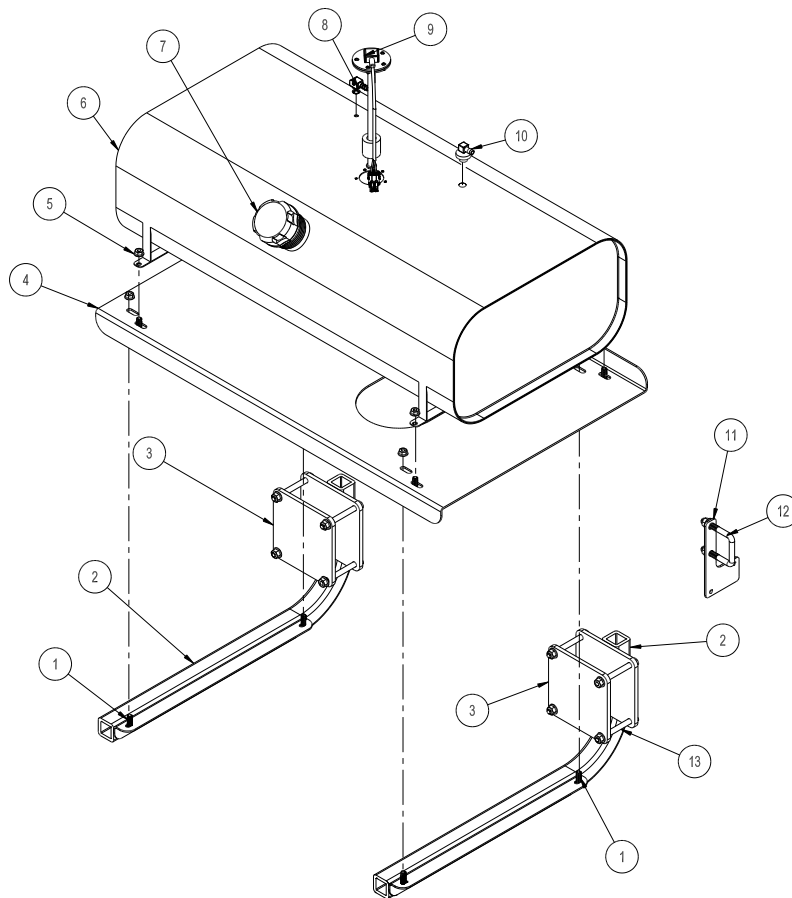

REF#	PART#	DESCRIPTION	QUANTITY
1	HB-38-16-100	Hex Bolt, $\frac{3}{8}$ - 16 x 1	4
	HNFL-38-16	Flange Whiz-loc Nut, $\frac{3}{8}$ - 16	4
2	30-321	Tank Mount	2
3	32-641	Tank Mount Plate	2
4	30-336	Tank Mount Plate	1
5	HB-38-16-100	Hex Bolt, $\frac{3}{8}$ - 16 x 1	4
	HNFL-38-16	Flange Whiz-loc Nut, $\frac{3}{8}$ - 16	4
6	32-531	20 Gal. Fuel Tank	1
7	30-351	Vented Fuel Cap	1
8	18-498	Barb Fitting	1
	8940-35	$\frac{5}{16}$ Fuel Hose x 35"	1
9	32-647	Level Sensor Assembly	1
10	32-648	Top Draw w/ Grommet	1
11	30-330	Fuel Regulator Mount	1
12	17-537	Square U-Hex Bolt	1
13	HB-38-16-350	Hex Bolt, $\frac{3}{8}$ - 16 x $3\frac{1}{2}$	8
	HNFL-38-16	Flange Whiz-loc Nut, $\frac{3}{8}$	8
NS	8940-28	$\frac{5}{16}$ " Fuel Hose x 28" (fuel pump to fuel regulator)	1
	8940-4	$\frac{5}{16}$ " Fuel Hose x 4" (fuel filter to fuel pump)	1
	8940-24	$\frac{5}{16}$ " Fuel Hose x 24" (fuel filter to top draw)	1
	8940-16	$\frac{5}{16}$ " Fuel Hose x 16" (fuel regulator to engine)	1
	18-186	Hose Clamp	2 per

# FOOT PEDAL LINKAGE DRAWING

PARTS

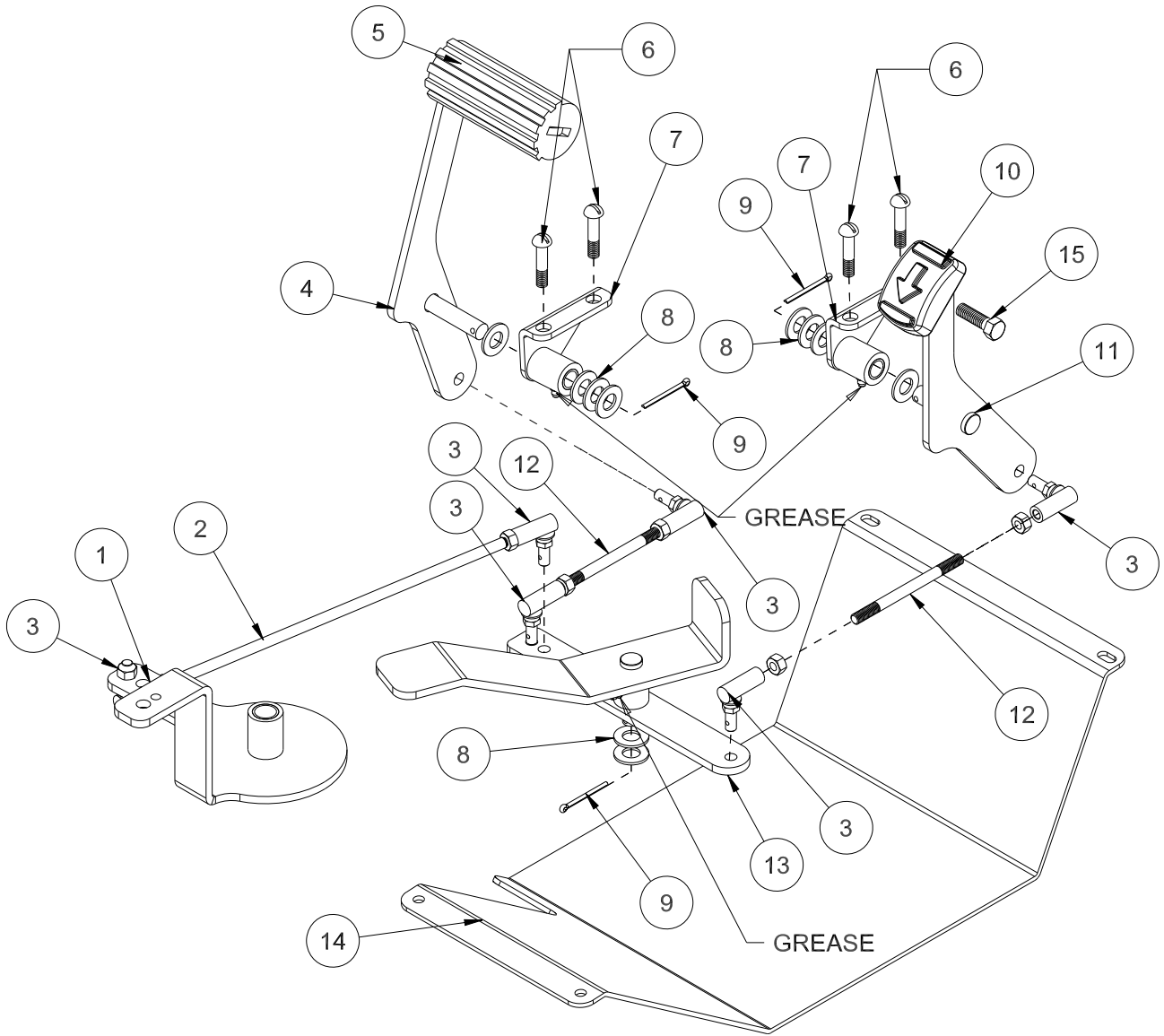

## FOOT PEDAL LINKAGE PARTS LIST

REF#	PART#	DESCRIPTION	QUANTITY
1	15-692	Pedal Relay	1
2	31-055	Linkage Rod	1
3	21-462	Ball Joints	6
	HN-516-24	Hex Nut, $\frac{5}{16}$ - 24	6
4	10-163	Forward Foot Pedal	1
5	48-066	Pedal Grip	1
6	HSTP-516-18-075	Phillips Machine Screw, $\frac{5}{16}$ - 18 x $\frac{3}{4}$	4
	HNFL-516-18	Flange Whiz-loc Nut, $\frac{5}{16}$ - 18	4
7	76-296	Pedal Mount	2
	18-234	Bushing	4
	HG-14-28-180	Grease Fitting	2
8	HMB-12-14	Machine Bushing, $\frac{1}{2}$ x 14GA	10
9	HP-18-100	Cotter Pin, $\frac{1}{8}$ x 1	3
10	45-022	Molded Pedal Pad	1
	HB-38-16-125	Hex Bolt, $\frac{3}{8}$ - 16 x $1\frac{1}{4}$	1
	HNTL-38-16	Nylon Lock Nut, $\frac{3}{8}$ - 16	1
11	31-050	Reverse Pedal	1
12	31-054	Pedal Rod	2
13	10-178	Relay	1
	18-234	Bushing	2
	HG-14-28-180	Grease Fitting, $\frac{1}{4}$ - 28 x 180°	1
14	30-288	Pedal Guard Plate	1
15	HB-38-16-125	Hex Bolt, $\frac{3}{8}$ - 16 x $1\frac{1}{4}$	1
	HNTL-38-16	Nylon Lock Nut, $\frac{3}{8}$ - 16	1

# LINKAGE DRAWING

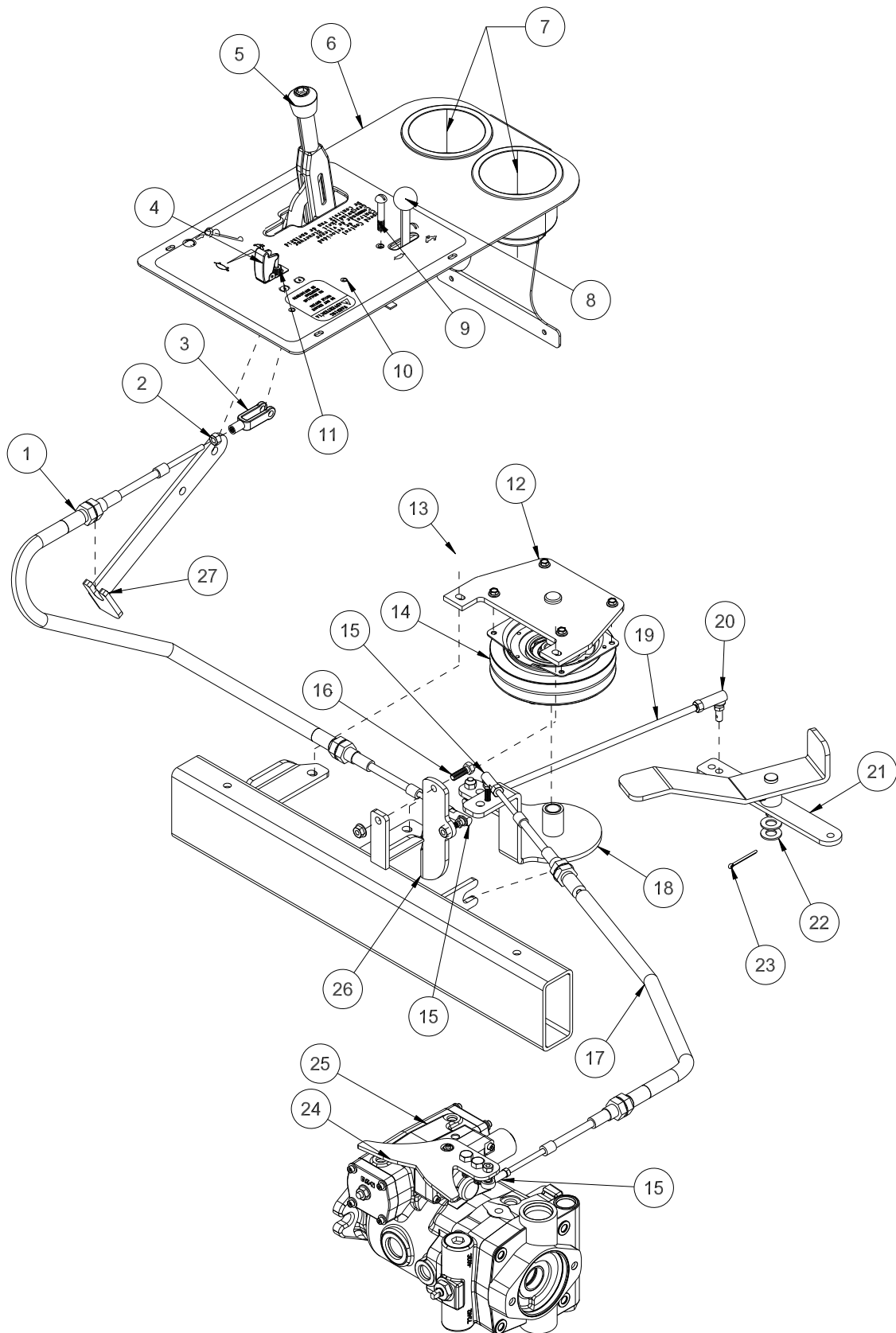

PARTS

## LINKAGE PARTS LIST

REF#	PART#	DESCRIPTION	QUANTITY
1	30-152	Push-Pull Cable	1
2	HN-516-24	Hex Nut, $\frac{5}{16}$ - 24	2
3	11-103	Linkage Yoke	1
4	30-143	Red Toggle Switch Guard	1
5	60-106	Spray Boss Control Lever	1
6	30-322	Center Console	1
7	15-781	Drink Cup Holder	2
8	32-521-01	Throttle	1
9	HSTP-14-20-075	Truss Head Screw, $\frac{1}{4}$ - 20 x $\frac{3}{4}$	2
	HNFL-14-20	Flange Whiz-loc Nut, $\frac{1}{4}$ - 20	2
10	30-331	Decal, Center Console	1
11	12-003	Park Brake Toggle Switch	1
12	30-027	Relay Plate	1
13	HB-38-16-125	Hex Bolt, $\frac{3}{8}$ - 16 x $1\frac{1}{4}$	2
	HNFL-38-16	Flange Whiz-loc Nut, $\frac{3}{8}$ - 16	2
14	33-084	Magnetic Coil	1
15	8-701	Ball Joint	3
	HN-14-20	Hex Nut, $\frac{1}{4}$ - 20	3
16	HB-516-18-100	Hex Bolt, $\frac{5}{16}$ - 18 x 1	1
	HW-516	Flat Washer, $\frac{5}{16}$	4
	HNTL-516-18	Nylon Lock Nut, $\frac{5}{16}$ - 18	1
17	13-632	Push Pull Cable	1
18	15-692	Pedal Relay	1
19	31-055	Linkage Rod	1
20	21-462	Ball Joint	2
	HN-516-24	Hex Nut, $\frac{5}{16}$ - 24	2
21	10-178	Relay	1
	18-234	Bushing	2
	HG-14-28-180	Grease Fitting, $\frac{1}{4}$ - 28 x 180°	1
22	HMB-12-14	Machine Bushing, $\frac{1}{2}$ x 14GA	2
23	HP-18-100	Cotter Pin, $\frac{1}{8}$ x 1	1
24	30-037	Shift Arm	1
25	30-102	Eaton Closed Loop Pump	1
26	30-159	Spray Boss Arm	1
27	30-158	Handle Mount	1

# FRONT AXLE DRAWING

PARTS

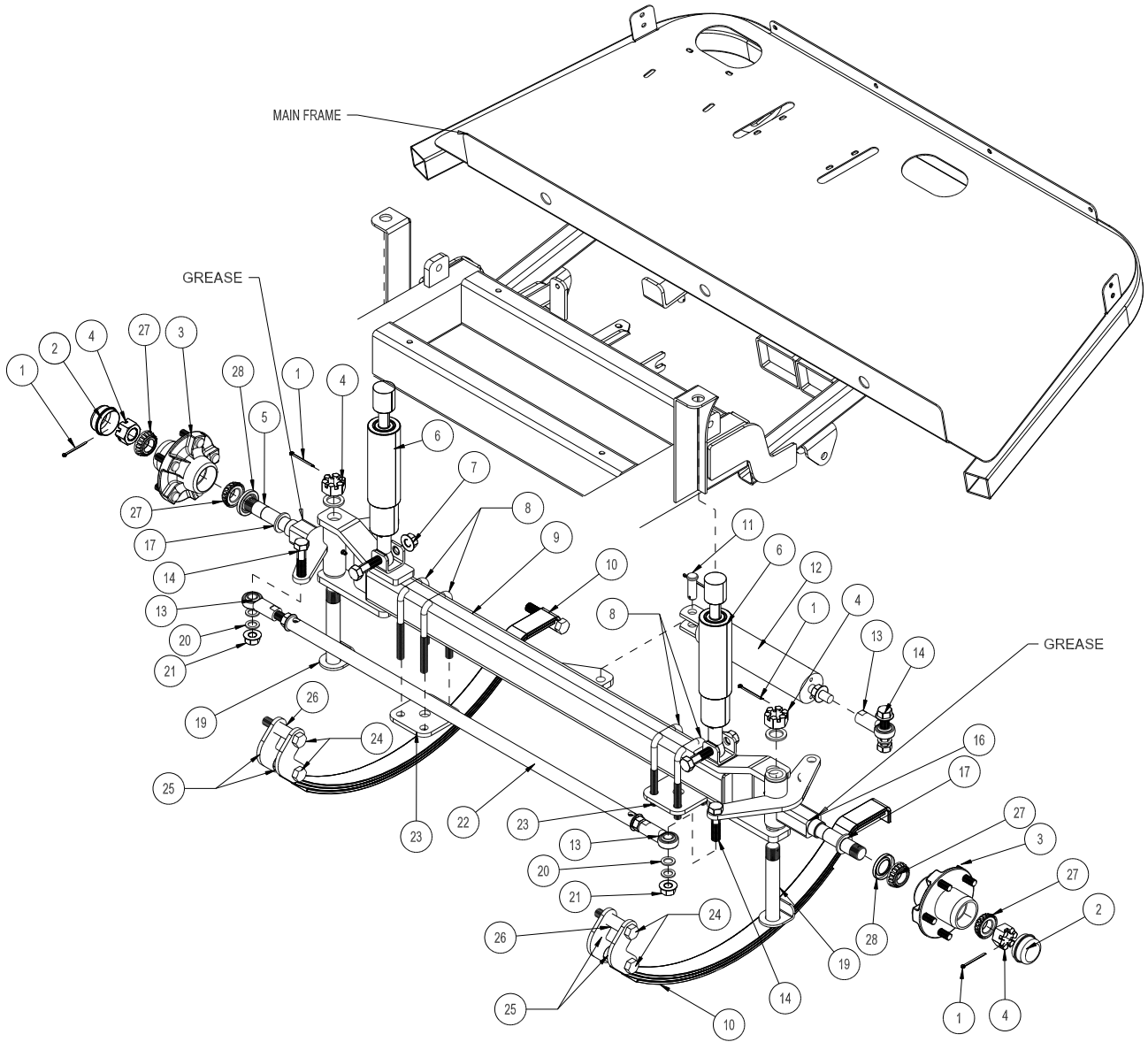

## FRONT AXLE PARTS LIST

REF#	PART#	DESCRIPTION	QUANTITY
1	HP-18-150	Cotter Pin, 1/8 - 1 1/2	4
2	33-073-02	Dust Cap	2
3	30-071	Hub Assembly	2
4	HNAR-100-14	Slotted Jam Nut, 1 - 14	4
5	30-070	Left Spindle	1
	HG-14-28-180	Grease Fitting, 1/4 -28 x 180°	1
6	20-617	Shock Absorber	2
7	HB-58-11-300	Hex Bolt, 5/8 - 11 x 3	2
	HNTL-58-11	Nylon Lock Nut, 5/8 -11	2
8	30-249	U-Hex Bolt	4
	HNFL-12-13	Flange Whiz-loc Nut, 1/2 - 13	8
9	30-252	Front Axle	1
10	20-740	Leaf Spring	
11	HCP-58-175	Clevis Pin, 5/8 x 1 3/4	1
	HP-18-100	Cotter Pin, 1/8 x 1	1
12	15-839	Steering Hydraulic Cylinder	1
	14-531	Seal Kit	1
	18-171	3/8 Seal Loc Adapter	2
13	18-154	Rod End	3
	HNJ-58-18	Jam Nut, 5/8 - 18	3
	HG-14-28-90	Grease Fitting, 1/4 - 28 x 90°	3
14	HB-58-11-250	Hex Bolt, 5/8 - 11 x 2 1/2	3
16	30-069	Right Spindle	1
	HG-14-28-180	Grease Fitting, 1/4 -28 x 180°	1
17	HMB-100-10	Machine Bushing, 1 x 10GA	6
19	16-076	King Pin	2
20	HMB-58-14	Machine Bushing, 5/8 x 14GA	6
21	HNTL-58-11	Nylon Lock Nut, 5/8 -11	3
22	30-254	Steering Link	1
23	20-538	Spring Mount	2
24	HB-916-18-325	Hex Bolt, 9/16 - 18 x 3 1/4	6
	HNTL-916-18	Nylon Lock Nut, 9/16 -18	6
25	30-253	Spring Shackle	4
26	30-251	Bushing (pressed in main frame)	2
27	11-042	Bearing, Inner/Outer	2
28	11-041	Seal	2

# OIL TANK DRAWING

PARTS

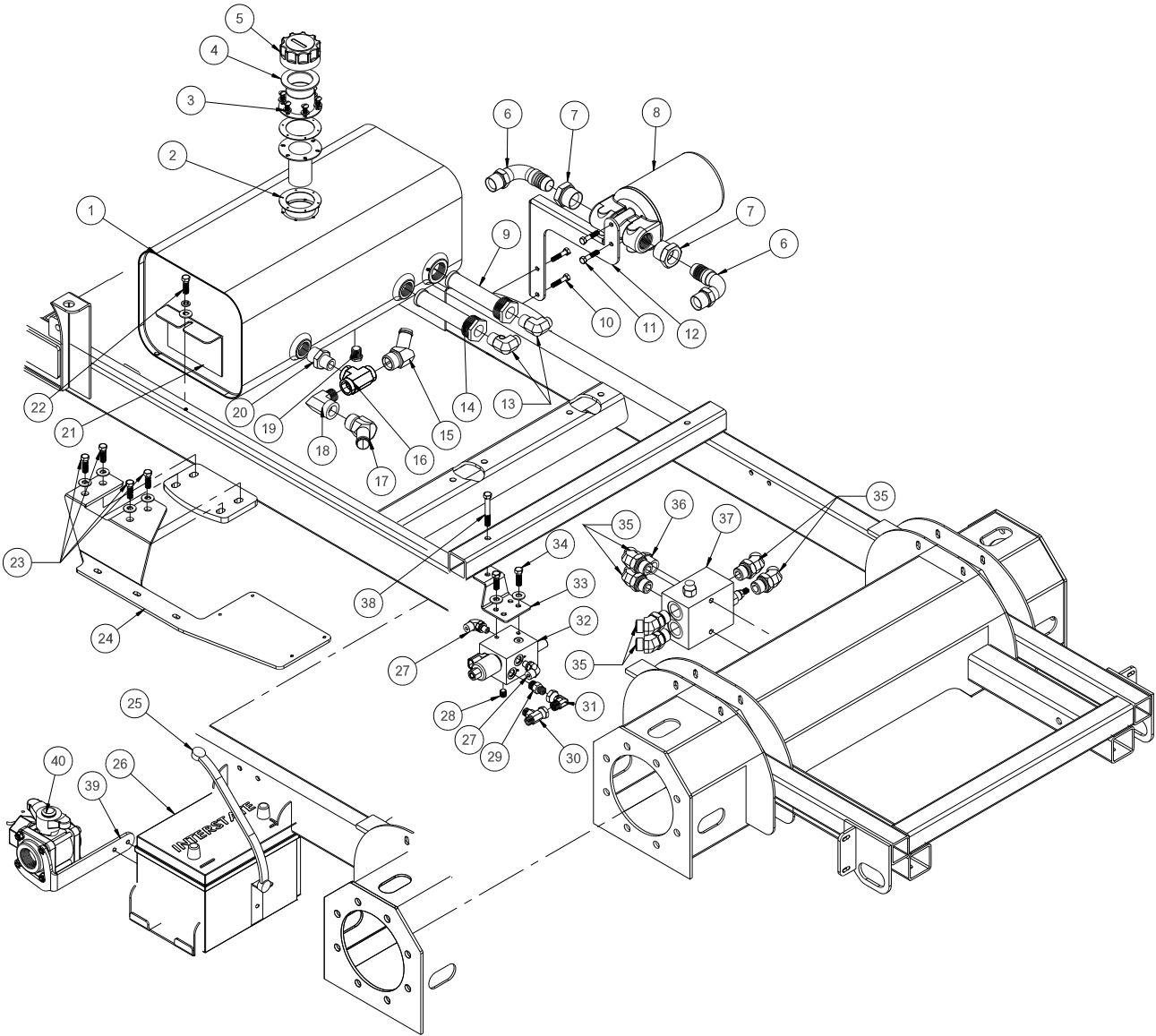

# OIL TANK PARTS LIST

REF#	PART#	DESCRIPTION	QUANTITY
1	30-025	Oil Tank	1
2	13-586-02	Bottom Gasket	1
3	13-586-03	Fuel Tank Neck	1
	HSM-10-32-063	Machine Screw, #10-32 x 5/8	6
	HWL-10	Lock Washer, #10	6
4	13-586-01	Cap Gasket	1
5	13-747	Filler Breather	1
6	18-397	90° Hose Barb Fitting	2
7	18-396	Reducer	2
8	72-146	Oil Filter Assembly	1
	60-334	Replacement Filter	1
9	60-213	Strainer	1
10	HB-516-18-125	Hex Bolt, 5/16 -18 x 1 1/4	2
	HNFL-516-18	Flange Whiz-loc Nut, 5/16 - 18	2
11	HB-516-18-100	Hex Bolt, 5/16 -18 x 1	2
	HW-516	Flat Washer, 5/16	2
	HWL-516	Lock Washer, 5/16	2
12	30-335	Oil Filter Mount	1
13	18-398	90° Barb Fitting	2
14	18-433	Strainer	1
15	18-407	5/8 - 45° Hose Barb Fitting	1
16	18-399	Tee	1
17	23-190	45° Hose Barb	1
18	18-140	Elbow	1
19	18-069	Pipe Plug	1
20	18-400	Pipe Nipple	1
21	30-063	Oil Tank Hold-down	2
22	HB-38-16-125	Hex Bolt, 3/8 -16 x 1 1/4	2
	HWL-38	Lock Washer, 3/8	2
	HW-38	Flat Washer, 3/8	2
23	HB-12-13-150	Hex Bolt, 1/2 - 13 x 1 1/2	4
	HW-12	Flat Washer, 1/2	4
	HNFL-12-13	Flange Whiz-loc Nut, 1/2 -13	4
24	30-293	Manifold Mount	1
25	8-603	Battery Hold Down	1
26	33-216	Battery	1
27	18-171	Elbow	2
28	23-126	O-ring Plug	1
29	18-306	Straight Thread Connector	1
30	18-308	Swivel Tee	1
31	18-309	90° Elbow	1
32	30-194	Manifold	1
	30-104-01	Cartridge Valve	1
	30-104-02	Coil	1
33	30-209	Brake Valve Mount	1
34	HB-38-16-125	Hex Bolt, 3/8 - 16 x 1 1/4	4
	HW-38	Flat Washer, 3/8	4
35	18-393	Elbow	6
36	18-321	Straight thread Connector	1
37	30-103	Hot Oil Shuttle Manifold	1
38	HB-38-16-275	Hex Bolt, 3/8 - 16 x 2 3/4	1
	HNFL-38-16	Flange Whiz-loc Nut, 3/8 - 16	1
39	30-326	Valve Mount	1
40	18-372	3-Way Valve	1

# SEAT PANEL DRAWING

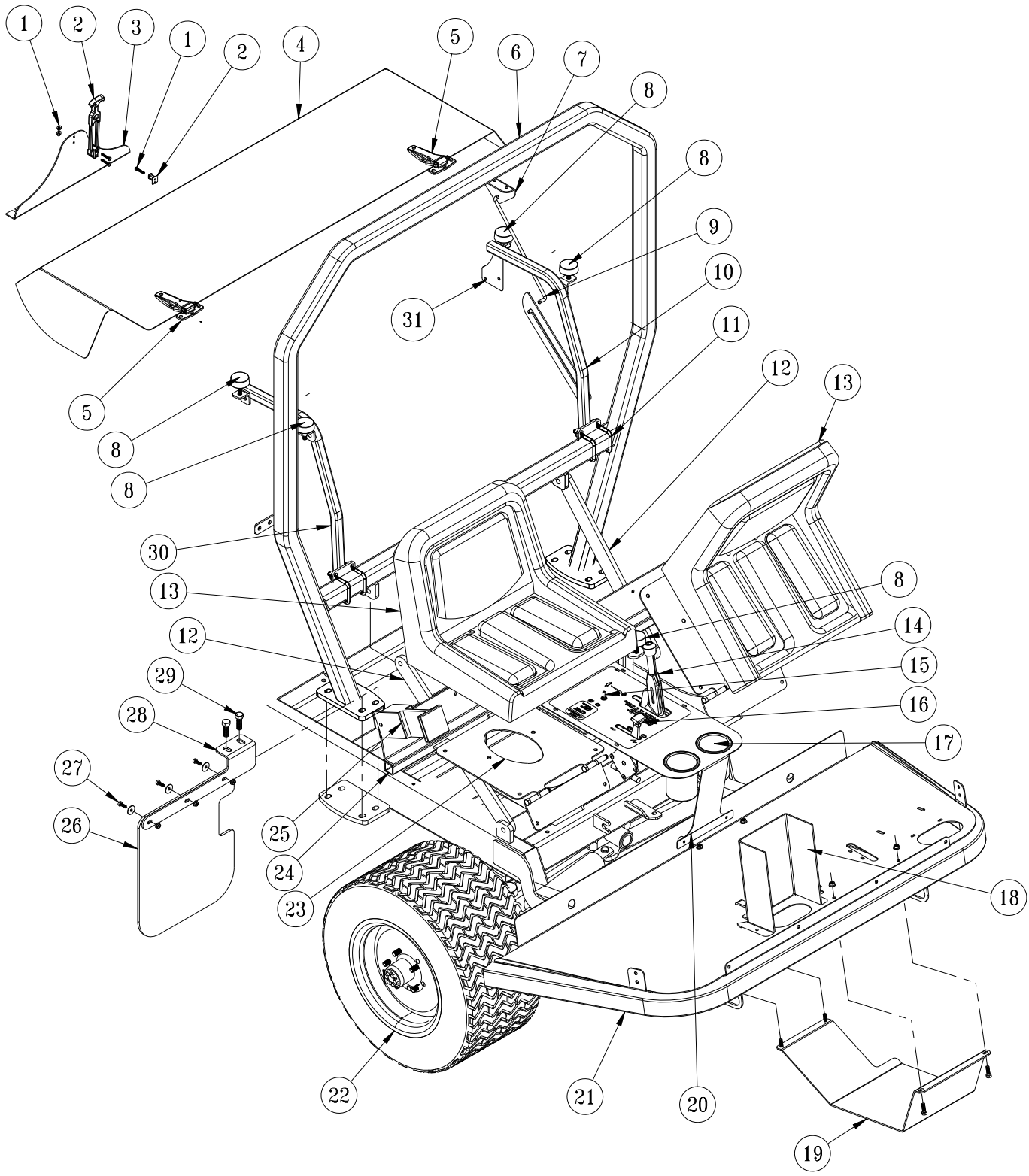

PARTS

## SEAT PANEL PARTS LIST

REF#	PART#	DESCRIPTION	QUANTITY
1	HSM 10-32-112	Machine Screw, #10-32 x 1 <sup>1</sup> / <sub>8</sub>	3
	HNFL-10-32	Flange Whiz-loc Nut, #10-32	3
2	15-437	Rubber Latch	1
3	30-307	Latch Mount	1
4	30-308	Engine Cover (Fiberglass)	1
5	27-055	Flush Hinge	2
	HSM 10-32-100	Machine Screw, #10-32 x 1	12
	HNFL-10-32	Flange Whiz-loc Nut, #10-32	12
6	31-063	Roll Bar	1
7	31-058	Rod Pivot	1
8	50-081	Rubber Bumper	8
	HNFL-38-16	Flange Whiz-loc Nut, <sup>3</sup> / <sub>8</sub> -16	8
9	31-059	Hood Rod	1
	HW-516	Flat Washer, <sup>5</sup> / <sub>16</sub>	2
	HP-18-100	Cotter Pin, <sup>1</sup> / <sub>8</sub> x 1	2
10	31-065	LH Hood Support	1
11	17-537	U-Hex Bolt	4
	HW-38	Flat Washer, <sup>3</sup> / <sub>8</sub>	8
	HNFL-38-16	Flange Whiz-loc Nut, <sup>3</sup> / <sub>8</sub> - 16	8
12	30-032	Roll Bar Brace	2
13	14-294	Seat Kit (includes * items)	2
	*14-800	Seat Rail Set	2
	*HSP-1260-340-250	Seat Spacer	8
14	60-106	Park Brake Handle Kit	1
15	12-003	Toggle Switch	1
	30-143	Toggle Switch Guard	1
16	32-521-01	Electronic Throttle	1
	32-521-12	Throttle Module only	
17	15-781	Drink Cup Holder	2
18	31-062	Hose Cover	1
19	30-288	Pedal Guard	1
	HB-516-18-100	Hex Bolt, <sup>5</sup> / <sub>16</sub> - 18 x 1	4
	HNFL-516-18	Flange Whiz-loc Nut, <sup>5</sup> / <sub>16</sub> - 18	4
20	30-322	Center Console	1
	30-331	Decal, Console	1
21	30-325	Main Frame	1
22	43-124	Turf Tread Tire and Wheel	2
	43-123-01	Tire	2
	43-058-02	Wheel	2
23	31-052	Seat Panel	2
24	31-066	Seat Frame	1
25	76-198-03	Seat Belt	2
26	20-658	Mud Flap	2
27	HB-14-20-075	Hex Bolt, <sup>1</sup> / <sub>4</sub> - 20 x <sup>3</sup> / <sub>4</sub>	6
	HWF-14-150	Fender Washer, <sup>1</sup> / <sub>4</sub> x 1 <sup>1</sup> / <sub>2</sub>	6
	HNFL-14-20	Flange Whiz-loc Nut, <sup>1</sup> / <sub>4</sub> - 20	6
28	30-291	RH Front Mud Flap Bracket	1
	30-292	LH Front Mud Flap Bracket (not shown)	1
29	HB-12-13-150	Hex Bolt, <sup>1</sup> / <sub>2</sub> - 13 x 1 <sup>1</sup> / <sub>2</sub>	8
	HNFL-12-13	Flange Whiz-loc Nut, <sup>1</sup> / <sub>2</sub> - 13	8
30	31-064	RH Hood Support	1
31	30-327	Overflow Tank Mount	1

# ENGINE DRAWING

PARTS

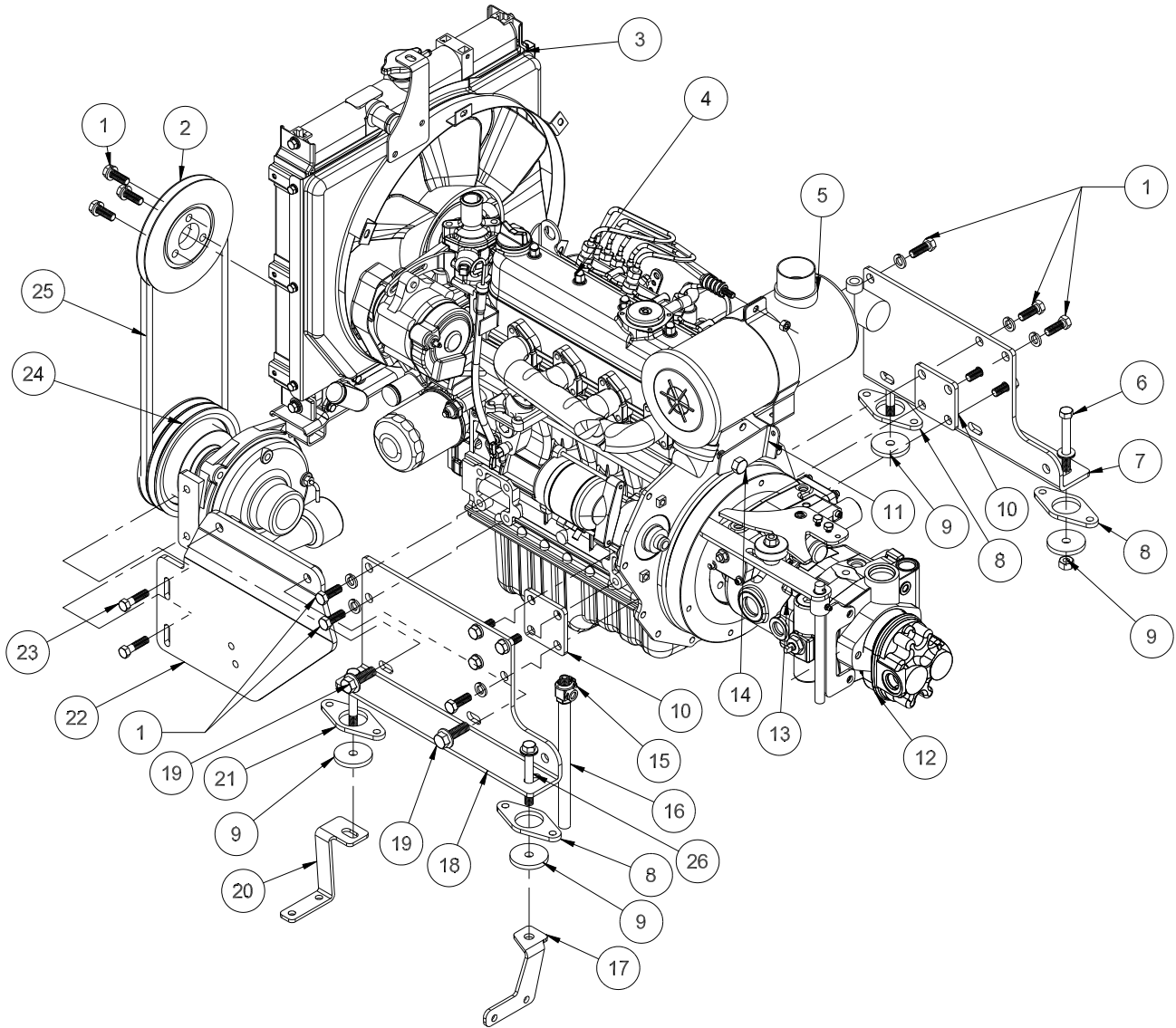

# ENGINE PARTS LIST

REF#	PART#	DESCRIPTION	QUANTITY
1	HBM-10-1.25-30	Hex Bolt, #10 - 1.25 x 30	15
	HWLM-10	Lock Washer, #10	15
2	30-206	Pulley	1
3		Radiator Kit	1
4	32-521	57HP Kubota Gas Engine	1
5	32-521-06	Air Cleaner	1
	32-521-07	Primary Filter	1
	32-521-08	Secondary (inner)Filter	1
7	30-040	Engine Mount LH	1
8	30-042-01	Engine Isolator	3
	HB-38-16-100	Hex Bolt, $\frac{3}{8}$ - 16 x 1	3
	HNFL-38-16	Flange Whiz-loc Nut, $\frac{3}{8}$ - 16	3
9	30-064	Motor Washer	4
	HB-716-14-300	Hex Bolt, $\frac{7}{16}$ - 14 x 3	2
	HW-716	Flat Washer, $\frac{7}{16}$	2
	HNTL-716-14	Nylon Lock Nut, $\frac{7}{16}$	2
10	30-038	Kubota Spacer	2
11	30-328	Timer Mount	1
12	76-197	Gear Pump	1
13	30-102	Eaton Closed Loop Pump	1
14	HB-12-13-125	Hex Bolt, $\frac{1}{2}$ - 13 x $1\frac{1}{4}$	1
	HWL-12	Lock Washer, $\frac{1}{2}$	1
15	30-212	Oil Drain Valve	1
16	8810-10	Black Hose, 10"	1
	18-040	Hose Clamp	1
17	30-324	RH Muffler Mount	1
18	30-041	Engine Mount RH	1
	HB-716-14-350	Hex Bolt, $\frac{7}{16}$ - 14 x $3\frac{1}{2}$	2
	HW-716	Flat Washer, $\frac{7}{16}$	2
	HNTL-716-14	Nylon Lock Nut, $\frac{7}{16}$	2
19	HB-516-18-075	Hex Bolt, $\frac{5}{16}$ - 18 x $\frac{3}{4}$	1
	HW-516	Flat Washer, $\frac{5}{16}$	1
	HNFL-516-18	Flange Whiz-loc Nut, $\frac{5}{16}$ - 18	1
20	30-323	LH Muffler Mount	1
21	30-042-14	515 Vibration Mount	1
	HB-38-16-125	Hex Bolt, $\frac{3}{8}$ - 16 x $1\frac{1}{4}$	1
	HNFL-38-16	Flange Whiz-loc Nut, $\frac{3}{8}$ - 16	1
22	30-207	Pump Mount	1
23	HB-12-13-150	Hex Bolt, $\frac{1}{2}$ - 13 x $1\frac{1}{2}$	2
	HWL-12	Lock Washer, $\frac{1}{2}$	2
24	16-998	Hypro Spray Pump	1
25	30-197	V-Belt	1

# PUMP DRAWING

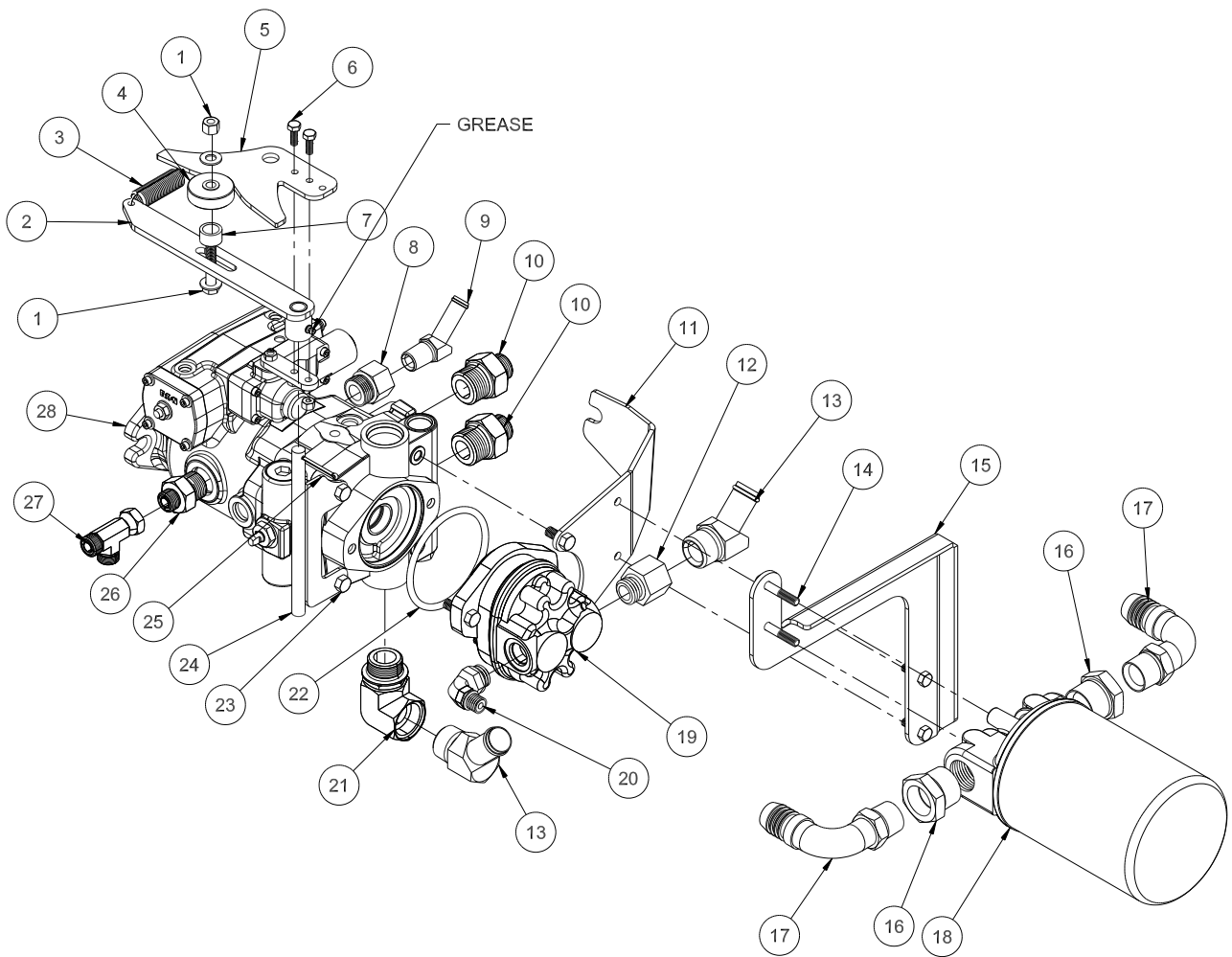

PARTS

# PUMP PARTS LIST

REF#	PART#	DESCRIPTION	QUANTITY
1	HB-38-16-200	Hex Bolt, $\frac{3}{8}$ - 16 x 2	1
	HW-38	Flat Washer, $\frac{3}{8}$	2
	HN-38-16	Hex Nut, $\frac{3}{8}$ - 16	1
2	30-082	Idler Arm	1
	HG-14-28-180	Grease Fitting, $\frac{1}{4}$ - 28 x 180°	1
	HMB-12-14	Machine Bushing, $\frac{1}{2}$ x 14GA	3
3	48-109	Spring	1
4	14-266	Ball Bearing	1
	18-270	Oilite Bushing	1
5	30-037	Shift Arm	1
6	HB-14-20-075	Hex Bolt, $\frac{1}{4}$ - 20 x $\frac{3}{4}$	2
	HNCL-14-20	Center Nylon Lock Nut, $\frac{1}{4}$ - 20	2
7	48-049	Shift Arm Spacer	1
8	18-333	Adapter	1
9	23-143	Connector	1
10	18-403	Adapter	2
11	30-329	Cable Mount	1
12	23-136	Straight Thread Reducer	1
13	23-190	45° Elbow, $\frac{3}{4}$ MPT	2
14	HB-516-18-100	Hex Bolt, $\frac{5}{16}$ - 18 x 1	2
	HW-516	Flat Washer, $\frac{5}{16}$	2
	HWL-516	Lock Washer, $\frac{5}{16}$	2
15	30-335	Oil Filter Mount	1
16	18-396	Reducer	2
17	18-397	90° Hose Barb Fitting	2
18	72-146	Oil Filter Assembly	1
	60-334	Replacement Filter	1
19	76-197	Gear Pump	1
	76-197-08	Seal Kit	1
20	18-350	Elbow, $\frac{3}{8}$	1
21	23-191	Elbow	1
22	23-145	Oring	1
23	HB-38-16-125	Hex Bolt, $\frac{3}{8}$ - 16 x $1\frac{1}{4}$	4
	HW-38	Flat Washer, $\frac{3}{8}$	4
24	30-029	Centering Arm Mount	1
25	HP-18-075	Cotter Pin, $\frac{1}{8}$ x $\frac{3}{4}$	1
26	18-404	Adapter	1
27	18-405	Run Tee	1
28	30-102	Eaton Closed Loop Pump	1

# COOLER AND EXHAUST DRAWING

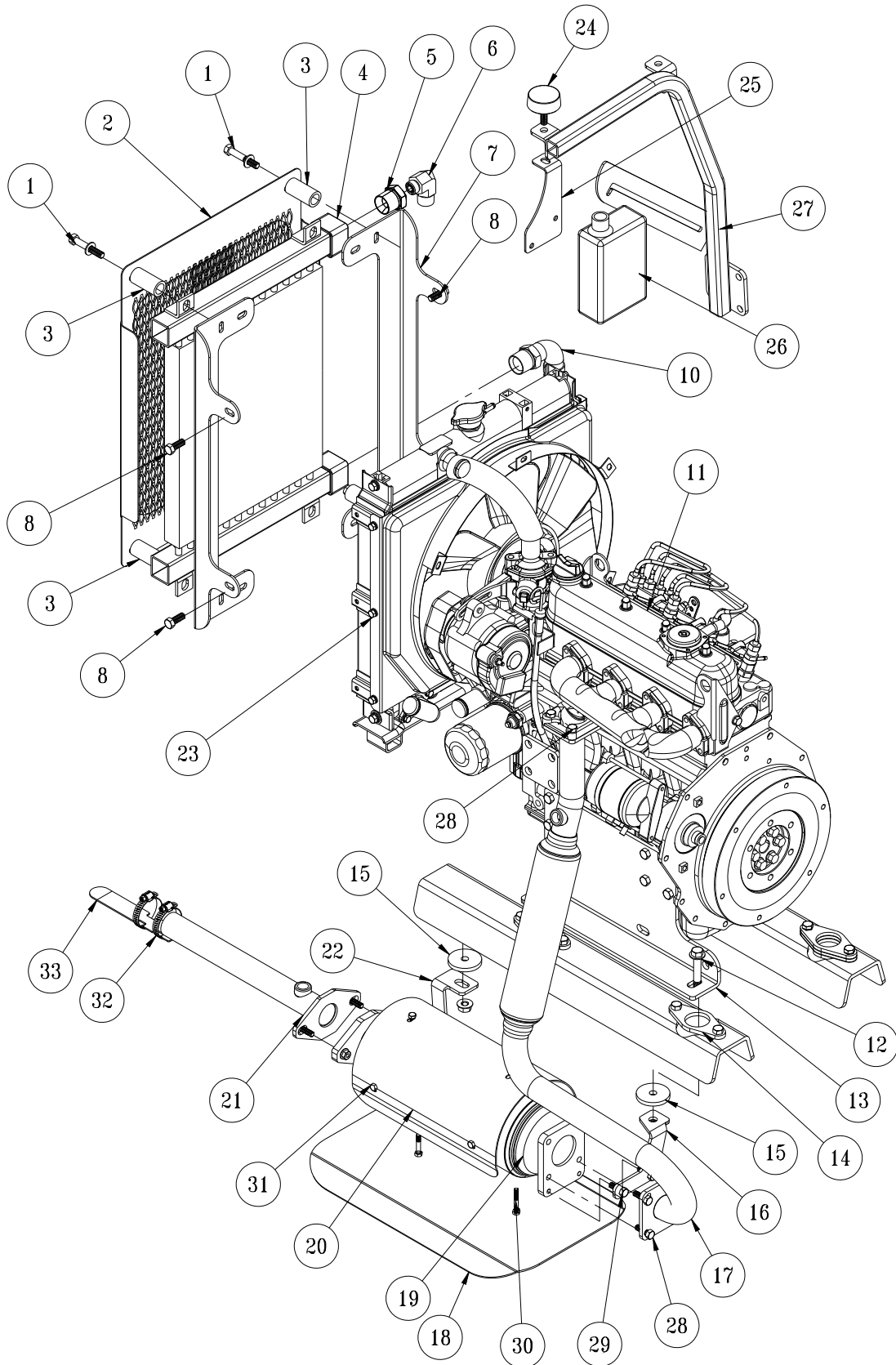

PARTS

## COOLER AND EXHAUST PARTS LIST

REF#	PART#	DESCRIPTION	QUANTITY
1	HB-38-16-275	Hex Bolt, $\frac{3}{8}$ - 16 x $2\frac{3}{4}$	4
	HNFL-38-16	Flange Whiz-loc Nut, $\frac{3}{8}$ - 16	4
2	30-043	Oil Cooler Cover	1
3	60-406	Spacer	4
4	30-105	Thermal Transfer Heat Exchanger	1
5	18-107	Pipe Thread Reducer	1
6	18-402	Hose Barb, $\frac{3}{4}$ x 90°	1
7	30-028	Cooler Mount	2
8	HBM-6-1-16	Metric Hex Bolt, M6 - 1 - 16	4
	HWLM-6	Metric Washer, M6	4
	HW-14	Washer, $\frac{1}{4}$	4
10	18-397	90° Hose Barb	1
11	32-521	Kubota 57 HP Gas Engine (includes ** items)	1
12	HB-38-16-100	Hex Bolt, $\frac{3}{8}$ - 16 x 1	1
	HNFL-38-16	Flange Whiz-loc Nut, $\frac{3}{8}$ - 16	1
13	30-041	Engine Mount RH	1
14	30-042-01	Engine Isolator	1
15	30-064	Motor Washer	2
16	30-324	RH Muffler Mount	1
	HB-516-18-100	Hex Bolt, $\frac{5}{16}$ - 18 x 1	2
	HW-516	Flat Washer, $\frac{5}{16}$	2
	HNTL-516-18	Nylon Lock Nut, $\frac{5}{16}$ - 18	2
17	30-340	Exhaust Pipe	1
18	32-539	Heat Shield	1
	HBM-6-1-40	Metric Hex Bolt, M6	2
	HWL-6	Lock Washer, M6	2
	HW-14	Flat Washer, $\frac{1}{4}$	2
**19		Muffler	1
20	32-593	Muffler Shield	1
21	30-341	Tailpipe	1
22	30-323	LH Muffler Mount	1
	HB-516-18-100	Hex Bolt, $\frac{5}{16}$ - 18 x 1	2
	HW-516	Flat Washer, $\frac{5}{16}$	2
	HNTL-516-18	Nylon Lock Nut, $\frac{5}{16}$ - 18	2
**23		Radiator Kit	1
24	50-081	Rubber Bumper	1
25	30-327	Overflow Tank Mount	1
26	32-521-02	Coolant Overflow Tank	1
27	31-065	LH Hood Support	1
28	HMB-8-1.25 x 20	Metric Hex Bolt, #8-1.25 x 40	8
	HWLM-8	Metric Lock Washer, M8	8
29	HB-516-18-100	Hex Bolt, $\frac{5}{16}$ - 18	2
	HW-516	Flat Washer, $\frac{5}{16}$	4
	HNFL-516-18	Flange Whiz-loc Nut, $\frac{5}{16}$ - 18	4
30	HBM-6-1-40	Metric Hex Bolt, #6 - 1 x 40	2
	HW-14	Flat Washer, $\frac{1}{4}$	2
	HWLM-6	Metric Lock Washer, M6	2
31	HBM-6-1-16	Metric Hex Bolt, #6 - 1 x 16	6
	HWLM-6	Metric Lock Washer, M6	6
32	18-116	Clamp	2
33	30-380	Heat Deflector	1

# REAR WHEEL DRIVE DRAWING

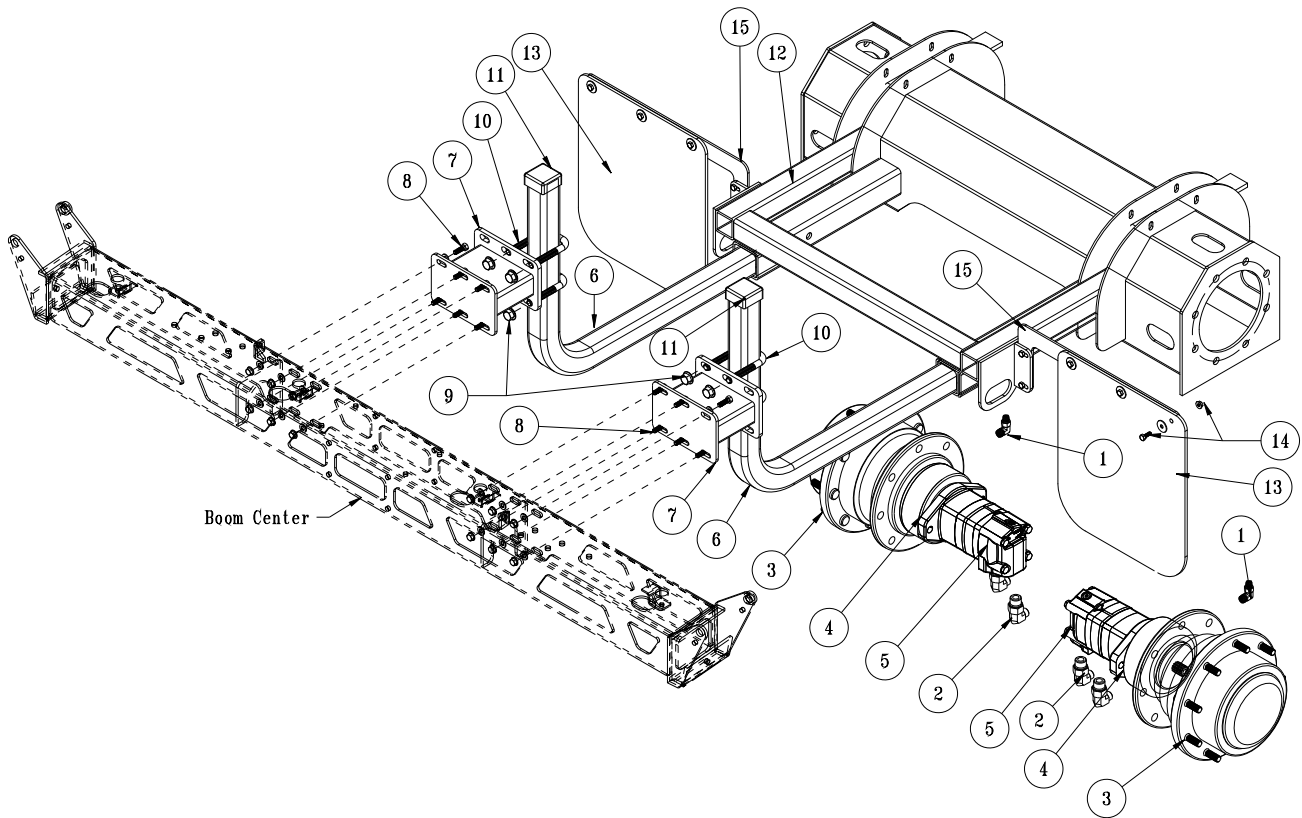

PARTS

## REAR WHEEL DRIVE PARTS LIST

REF#	PART#	DESCRIPTION	QUANTITY
1	18-394	Elbow	2
2	18-301	Straight Thread Elbow	4
3	30-099	Auburn Wheel Drive	2
4	30-100	Micro Spring Hydraulic Brakes	2
5	30-101	Eaton 2000 Series Hydraulic Motor	2
	30-101-11	Seal Kit	2
6	17-615	Boom Tube	2
7	17-614	Boom Spacer	2
8	HB-516-18-100	Hex Bolt, $\frac{5}{16}$ - 18 x 1	12
	HW-516-18	Flat Washer, $\frac{5}{16}$	12
	HNFL-516-18	Flange Whiz-loc Nut, $\frac{5}{16}$ - 18	12
9	HNFL-12-13	Flange Whiz-loc Nut, $\frac{1}{2}$ - 13	8
10	20-555	U-Hex Bolt	4
11	16-557	Square Cap	2
12	30-325	Main Frame	1
13	20-657	Mud Flap	2
14	HB-14-20-075	Hex Bolt, $\frac{1}{4}$ - 20 x $\frac{3}{4}$	6
	HWF-14-150	Fender Washer, $\frac{1}{4}$ x $1\frac{1}{4}$	6
	HNFL-14-20	Flange Whiz-loc Nut, $\frac{1}{4}$ - 20	6
15	30-290	Rear Mud Flap Bracket	2
	HB-516-18-100	Hex Bolt, $\frac{5}{16}$ - 18 x 1	4
	HNFL-516-18	Flange Whiz-loc Nut, $\frac{5}{16}$ - 18	4

# TANK DRAWING

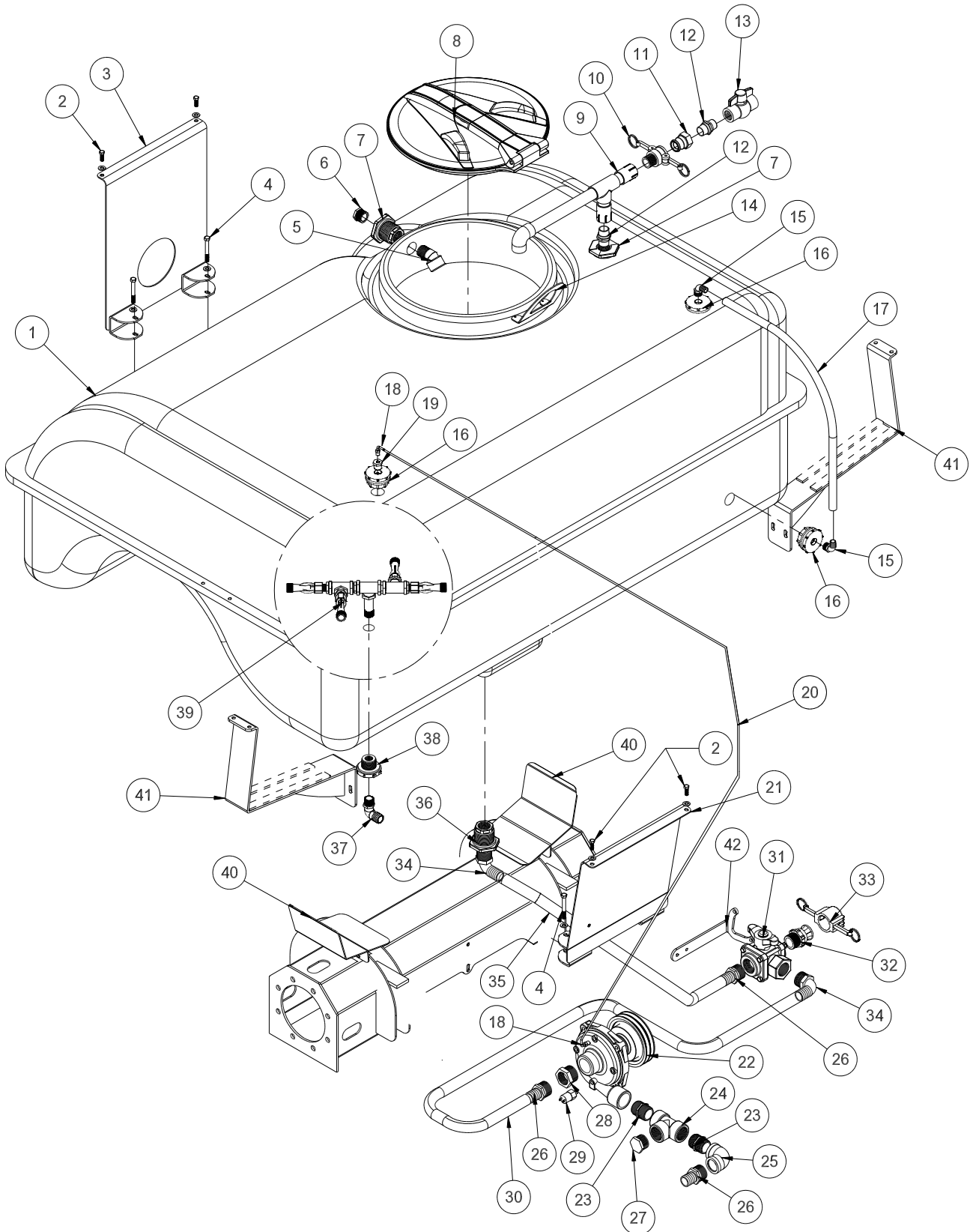

PARTS

# TANK PARTS LIST

REF#	PART#	DESCRIPTION	QUANTITY
1	30-095	318 Gallon Tank (fiberglass)	1
2	HB-38-16-200	Hex Bolt, $\frac{3}{8}$ - 16 X 2	4
	HW-38	Flat Washer, $\frac{3}{8}$	4
	HNTL-38-16	Nylon Lock Nut, $\frac{3}{8}$ - 16	4
3	30-051	Rear Tank Mount	1
	8828-16	Foam Tape	1
4	HB-38-16-300	Hex Bolt, $\frac{3}{8}$ - 16 x 3	4
	HW-38	Flat Washer, $\frac{3}{8}$	4
	HNFL-38-16	Flange Whiz-loc Nut, $\frac{3}{8}$ - 16	4
5	16-971	45° Elbow (inside tank)	1
6	16-162	Hex Plug, 1"	1
7	16-945	Double Thread Fitting	2
8	16-953	Hinged Lid Well	1
	16-953-01	Gasket for Cover	1
	HRS-316-100	Rivet, $\frac{3}{16}$ x 1	10
	HW-316	Washer, $\frac{3}{16}$	10
	20-663	EPDM Tank Lid Gasket	1
	16-169	Strainer Basket	1
9	14-365	Air Gap Filler	1
	16-162	Hex Plug 1" (inside tank)	1
10	16-962	1" Coupler	1
11	16-961	1" Adapter	1
12	16-851	1" Close Nipple	2
13	18-448	1" Ball Valve	1
14	10-639	Lid Stop	1
	HRS-36-100	Rivet, $\frac{3}{16}$ x 1	2
	HW-316	Flat Washer, $\frac{3}{16}$	2
15	16-937	Elbow	2
16	33-495	Bulkhead Fitting	3
17	30-359	Site Gauge with Decal	1
	18-224	Hose Clamp	2
18	18-475	Male Elbow	2
19	33-496	Reducer Bushing	1
20	9038-44	Tubing	1
21	30-050	Front Tank Mount	1
	8828-16	Foam Tape	1
22	16-998	Hypro Pump	1
23	16-880	Close Nipple	2
24	18-390	Tee	1
25	16-182	90° Elbow	1
26	16-161	Fitting	3
27	10-389	Plug	1
28	16-825	Hex Bushing	1
29	33-480	Pressure Switch	1
30	8897-37	1 $\frac{1}{4}$ " Discharge Hose	1
31	18-372	3-Way Valve	1
	18-372-01	Handle	1
32	16-180	Quick Coupler Male	1
33	16-935	Quick Coupler Cap	1
34	16-156	Elbow	1
35	8897-21	1 $\frac{1}{4}$ " Discharge Hose	1
36	16-194	Anti-Vortex Fitting	1
37	16-155	Elbow	1
38	16-150	Double Thread Fitting	1
39		Turbo Quad Agitator Assembly	1
40	30-062	Rear Tank Support	2
	30-166	Tank Pad	2
41	30-346	Tank Carrier	2
	8828-26	Foam Tape	4
42	30-326	Valve Mount	1

# TURBO-QUAD AGITATOR

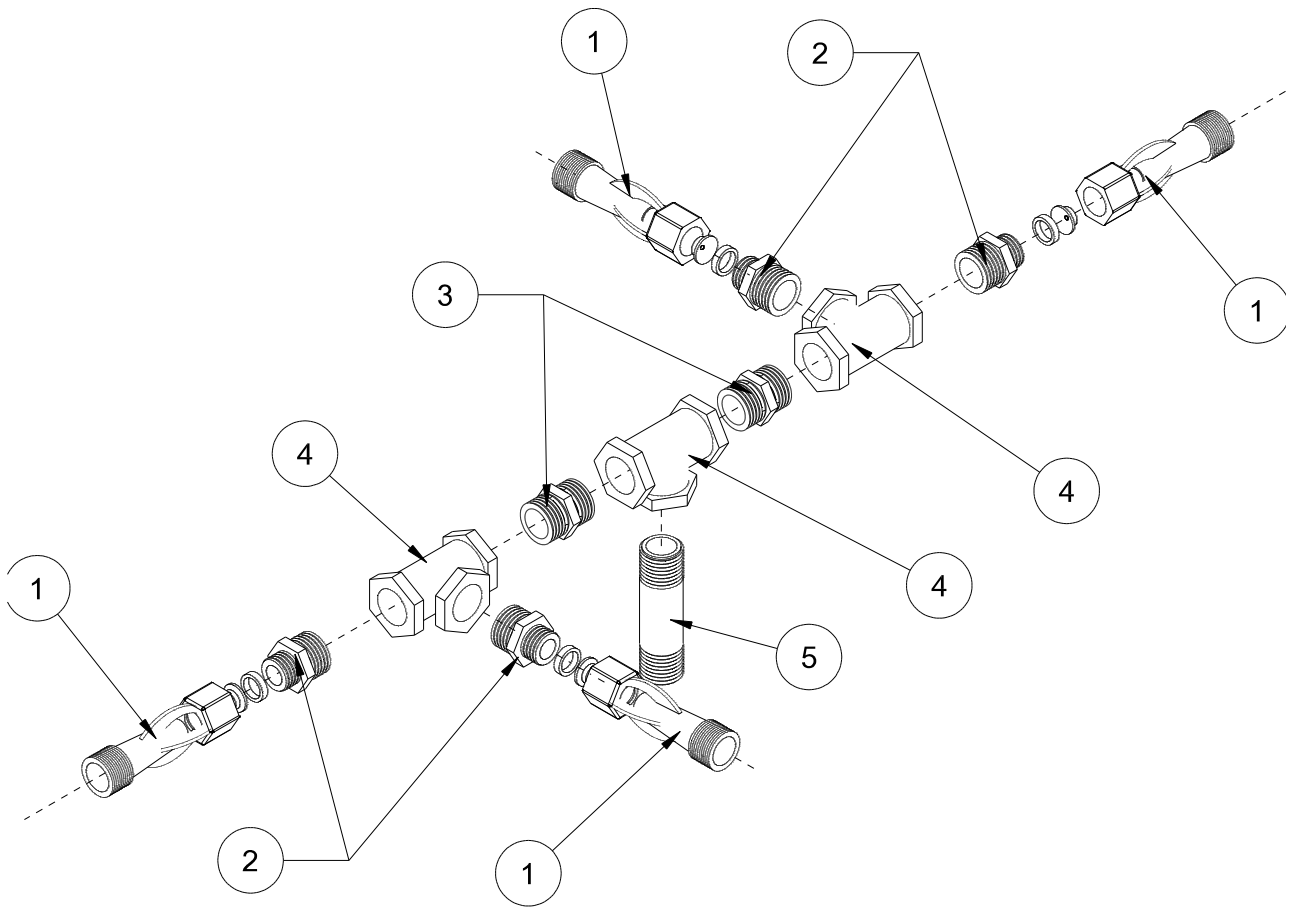

REF#	PART#	DESCRIPTION	QUANTITY
1	16-036	Agitator Jet (Includes one each $\frac{1}{8}$ ", $\frac{5}{53}$ ", and $\frac{3}{16}$ " orifices)	4
2	16-173	Reducer, $\frac{3}{4}$ x $\frac{1}{2}$	4
3	16-158	Close Nipple, $\frac{3}{4}$ x $\frac{3}{4}$	2
4	16-157	Female Pipe Thread Tee, $\frac{3}{4}$ x $\frac{3}{4}$ x $\frac{3}{4}$	3
5	16-172	Nylon Nipple, $\frac{3}{4}$ NPT x $3\frac{1}{2}$	1

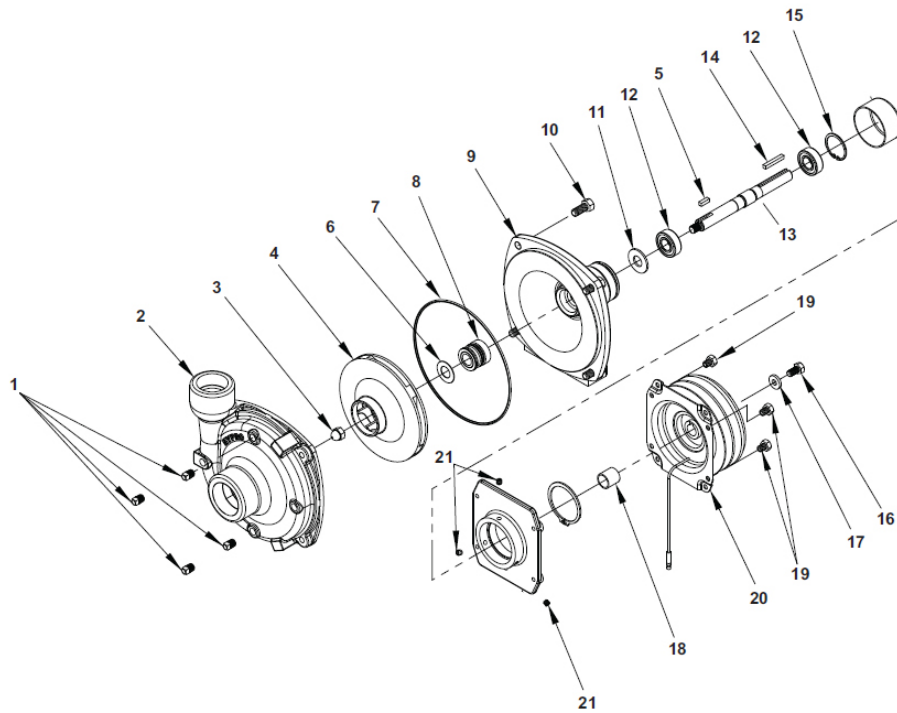

**△ IMPORTANT**

**WHEN SERVICING THE SPRAY PUMP OR FILTER, ALL CONTROL VALVES MUST BE SHUT OFF IF THERE IS LIQUID IN THE TANK.**

REF#	PART#	DESCRIPTION	QUANTITY
1	16-998-01	Drain Plug	4
2	16-998-02	Pump Casing	1
3		Impeller Nut	1
4	16-966-16	Impeller	1
5	16-966-11	Key	1
6	16-998-10	Gasket	1
7*	16-998-04	O-Ring	1
8*	16-967	Mechanical Seal (Silicon Carbide)	1
9	16-998-06	Mounting Flange	1
10	16-998-07	Hex Bolt	
11	16-966-06	Slinger Ring	1
12	16-966-10	Ball Bearing	2
13	16-966-12	Pump Shaft	1
14	16-822-20	Key	1
15	16-966-13	Bearing Retainer	1
16	16-994-05	Hex Bolt	1
17	16-994-06	Retaining Washer	1
18	16-994-03	Spacer	1
19		Hex Bolt	4
20	16-994-01	Clutch	1
21	16-994-04	Set Screw	3
	16-998-12	Pump Only	
*	16-967	Silicone - Carbon Seal Kit	

# 15-301 ORBITROL DRAWING

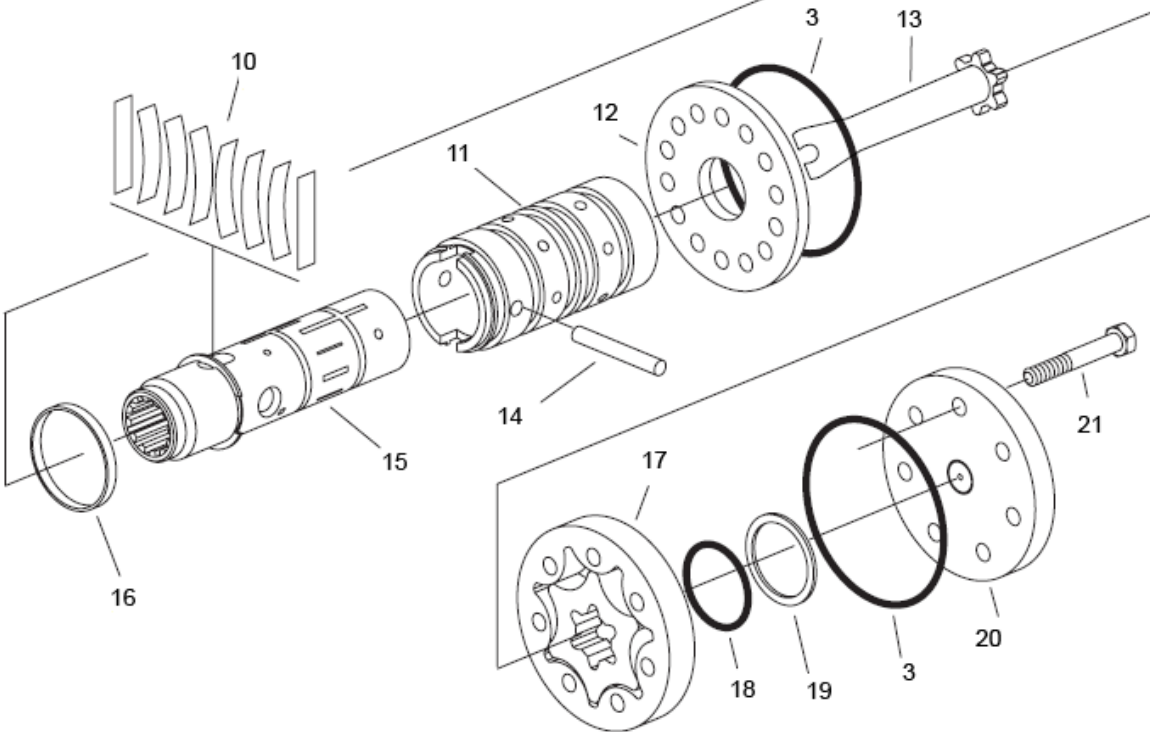
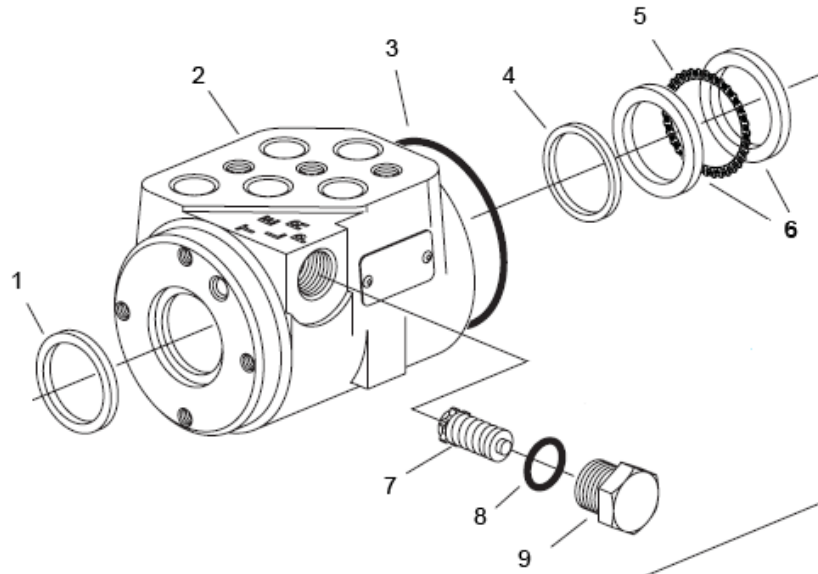

PARTS

# 15-301 ORBITROL PARTS LIST

REF #	PART #	DESCRIPTION	QUANTITY
1	10-576-04	Dust Seal	1
2		Housing	1
3**		O-Ring Seal	3
4**		Quad Seal	1
5	10-576-03	Thrust Bearing	1
6	10-576-02	Bearing Race	2
7		Manual Steering Relief Valve	1
8**		O-ring	1
9		Plug	1
10‡		Standard Torque Centering Springs	1
11		Sleeve	1
12	15-301-06	Wear Plate	1
13	10-576-01	Drive	1
14	15-301-08	Drive Pin	1
15		Spool	1
16‡		Spring Retaining Ring	1
17	10-576-05	Gerotor	1
18**		O-Ring	1
19**		Seal Ring	1
20	15-301-03	End Cap	1
21	10-576-06	Cap Screw	7
**	15-301-01	Seal Kit	1
‡	15-301-15	Centering Spring Kit	1

## 15-301 Orbitrol Specifications

Inlet Relief Valve Setting	1020 psi (70 bar)
Nominal Flow	3 gpm (11 lpm)
Displacement	4.50 cu. in/ R (73.8 cu cm/R)
Check Valve for Manual Steering	Yes
Inlet Pressure Rating	2030 psi (140 bar)
Return Pressure Rating	145 psi (10 bar) Maximum
Fluid	SAE 10W-40 API Service SJ or higher Motor Oil
Ports	<sup>9</sup> / <sub>16</sub> - 18 SAE O-Ring 4 Ports

# 76-197 EATON GEAR PUMP

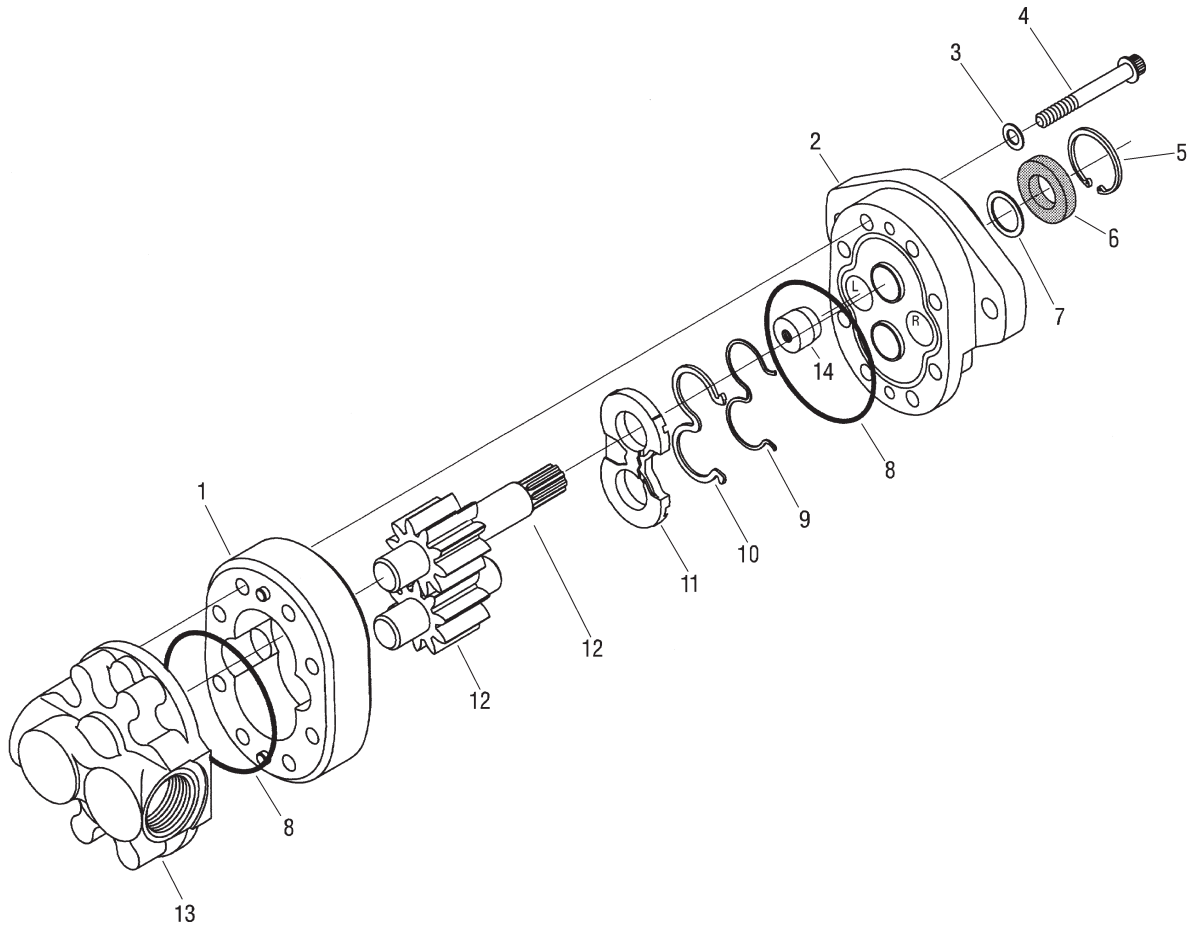

PARTS

REF#	PART#	DESCRIPTION	QUANTITY
1		Body	1
2	76-197-01	Front Plate	1
3*		Washer	4
4	76-197-06	Cap Screw	8
5	76-197-07	Retaining Ring	1
6*		Shaft Seal	1
7	33-061-15	Washer	1
8*		O-Ring	2
9*		Backup Gasket	1
10*		Seal	1
11*		Wear Plate	1
12	76-197-04	Shaft (comes with Idler Gear)	1
13	76-197-02	Back Plate	1
14*		Plug	1

# 30-101 EATON MOTOR DRAWING

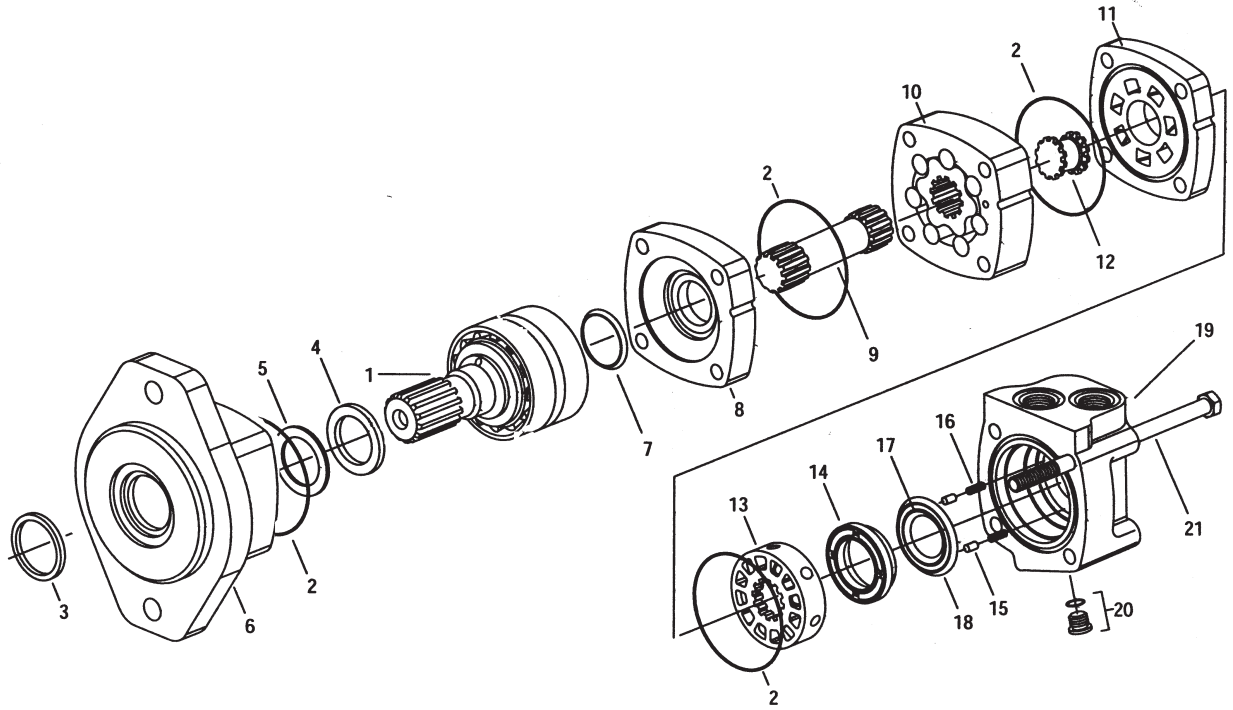

REF#	PART#	DESCRIPTION	QUANTITY
1	30-101-01	Shaft and Bearing Kit (7/8 splined 13T)	1
2*		Seal	4
3*		Exclusion Seal	1
4*		Shaft Seal	1
5*		Back Up Ring	1
6	30-101-02	Bearing Housing	1
7*		Shaft Face Seal	1
8	30-101-03	Wear Plate	1
9	30-101-04	Main Drive	1
10	30-101-05	Geroter	1
11	30-101-06	Valve Plate	1
12	14-207	Valve Drive	1
13	14-208	Valve	1
14	30-101-07	Balance Ring	1
15	14-210	Balance Ring Pin	2
16	14-209	Compression Spring	2
17*		Inner Face Seal	1
18*		Outer Face Seal	1
19	30-101-08	Valve Housing	1
20	30-101-09	Plug Assembly	1
*		O-ring	1
21	30-101-10	Cap Screw	4
*	76-197-08	Seal Kit	

# 30-102 EATON PUMP DRAWING

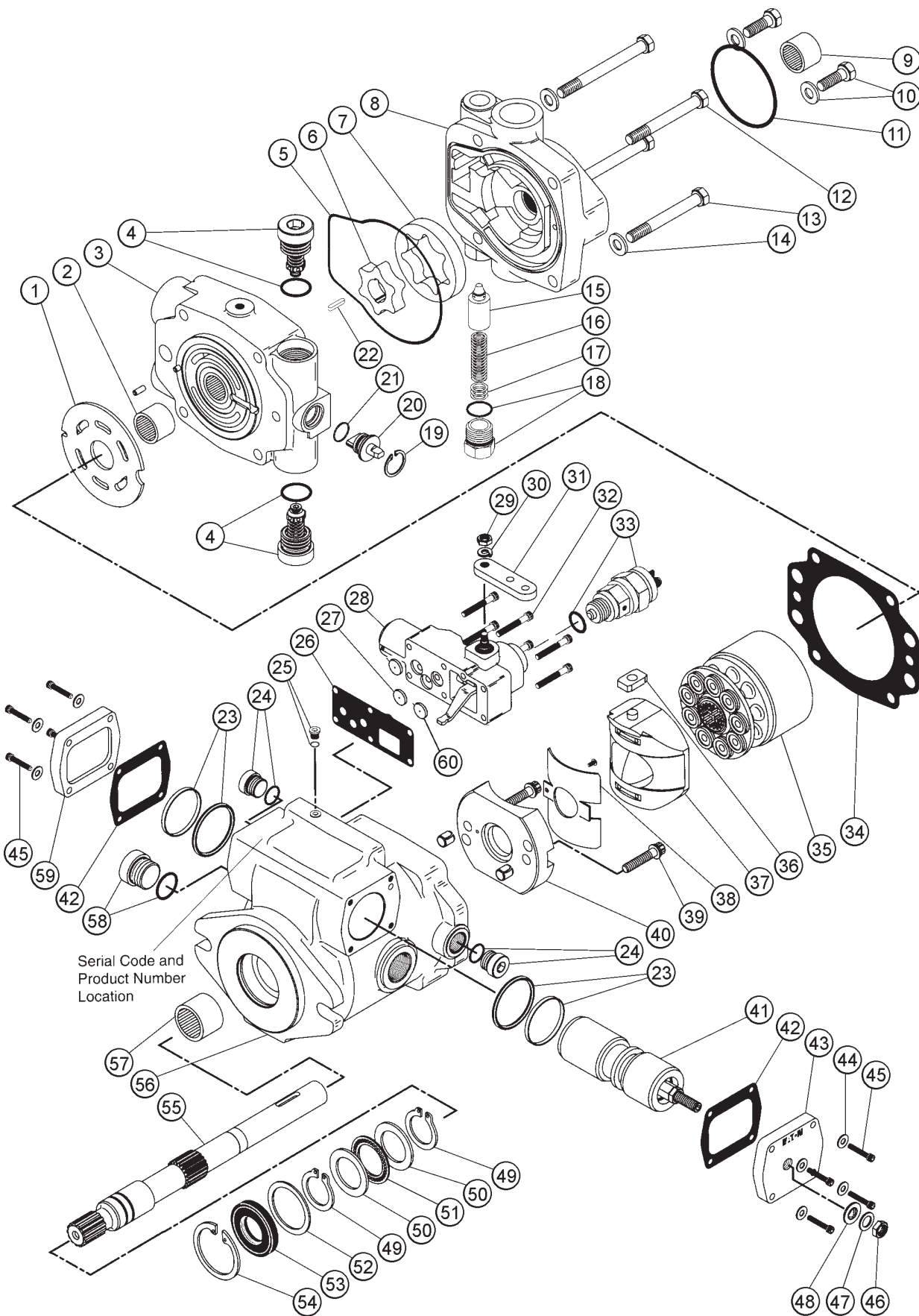

PARTS

## 30-102 EATON PUMP PARTS LIST

REF#	PART#	DESCRIPTION	QUANTITY
1	33-058-16	Valve Plate (CW Rotation)	1
2	33-058-26	Bearing (Press Fit)	1
3		Back Plate Assembly	1
4		Relief Valve S/A	2
*		O-Ring	2
5*		Molded O-Ring	1
6	33-058-38	Inner Ring Gerotor	1
7	33-058-39	Outer Ring Gerotor	1
8	33-058-35	Charge Pump Adapter Assembly	1
9	33-058-46	Bearing (Press Fit)	1
10		Hex Bolt and Washer	2
11*		O-Ring	1
12	33-058-14	Cap Screw, $\frac{3}{8}$ - 16 x 4	2
13	33-058-13	Cap Screw, $\frac{3}{8}$ - 16 x $3\frac{1}{2}$	2
14		Washer	4
15		Poppet	1
16	33-058-49	Spring	1
17	33-058-48	Shims	As Required
18	33-058-47	Plug	1
*		O-Ring	1
19*		Retaining Ring	1
20		Bypass Valve Actuator	1
21*		O-Ring	1
22	33-058-34	Key	1
23*		Seal Sub-Assembly	2
24	33-058-32	Plug S/A	2
*		O-Ring	2
25	33-058-19	Plug Sub-Assembly	1
*		O-Ring	1
26*	30-102-04	Control Housing Gasket	1
27	33-058-40	Supply Valve Orifice	1
28	33-058-37	Servo Control Assembly	1
29	33-058-29	Nut	1
30	33-058-30	Lock Washer	1
31	33-058-36	Control Arm	1
32	33-058-15	Cap Screw	6
33*	32-102-01	Interlock Switch	1
34*		Housing Gasket	1
35	33-058-04	Rotating Kit Assembly	1
36	33-058-06	Servo Piston Follower	1
37	33-058-09	Swash Plate S/A	1
38		Bushing	1
39		Cap Screw	2
*  	33-058-01	Seal Repair Kit	

(Continued on next page)

# 30-102 EATON PUMP DRAWING

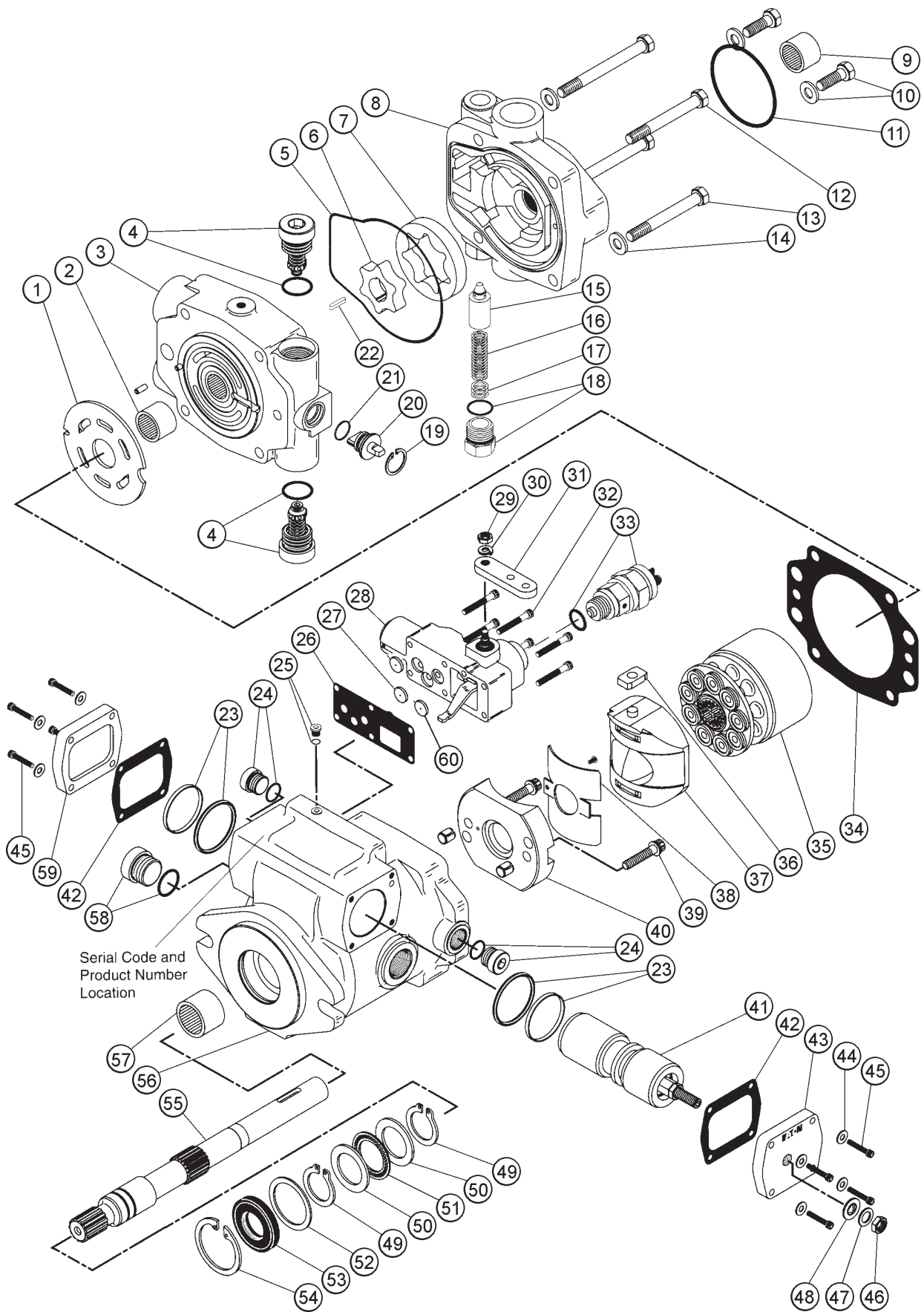

Serial Code and Product Number Location

PARTS

# 30-102 EATON PUMP PARTS LIST

REF#	PART#	DESCRIPTION	QUANTITY
40		Cradle Sub-Assembly	1
41		Servo Piston Assembly	1
42*		Cover Plate Gasket	2
43	33-058-08	Cover Plate	1
44	33-058-43	Washer	8
45	33-058-03	Cap Screw, #10 - 24 x 1	8
46	33-058-02	Jam Nut	1
47	33-058-42	Washer	1
48*		Seal Washer	1
49*		Retaining Ring	2
50	33-058-10	Thrust Race	2
51	33-058-11	Thrust Bearing	1
52	33-058-31	Washer	1
53*	33-058-52	Shaft Seal	1
54*		Retaining Ring	1
55	33-058-28	Drive Shaft	1
56		Housing Assembly	1
57	33-058-18	Bearing (Press Fit)	1
58	33-058-33	Plug S/A	1
*		O-Ring	1
59	33-058-07	Cover Plate	1
60	33-058-51	Control Valve Orifice	2
*	33-058-01	Seal Repair Kit	
NS	30-102-01	Lockout Switch(included in Seal Repair Kit)	1
See Below	30-102-02	Wiper Seal (included in Seal Repair Kit)	1
See Below	30102-03	O-Ring (included in Seal Repair Kit)	1
NS	23-145	Oring (between gear pump and hydro pump)	1

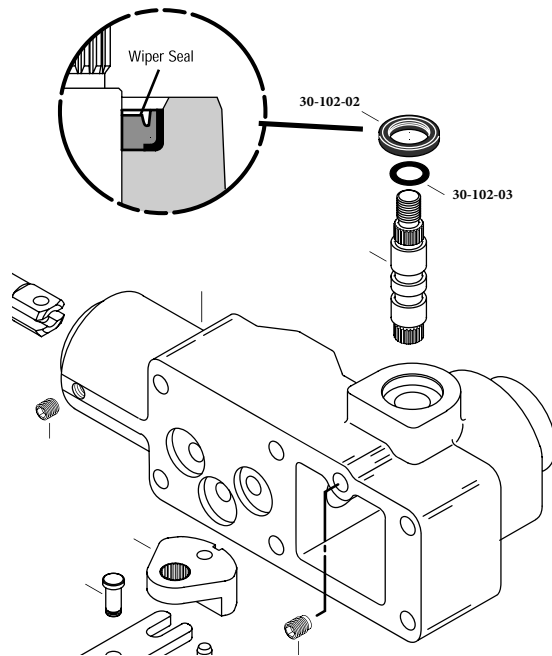

# 30-099 AUBURN® POWER WHEEL DRAWING

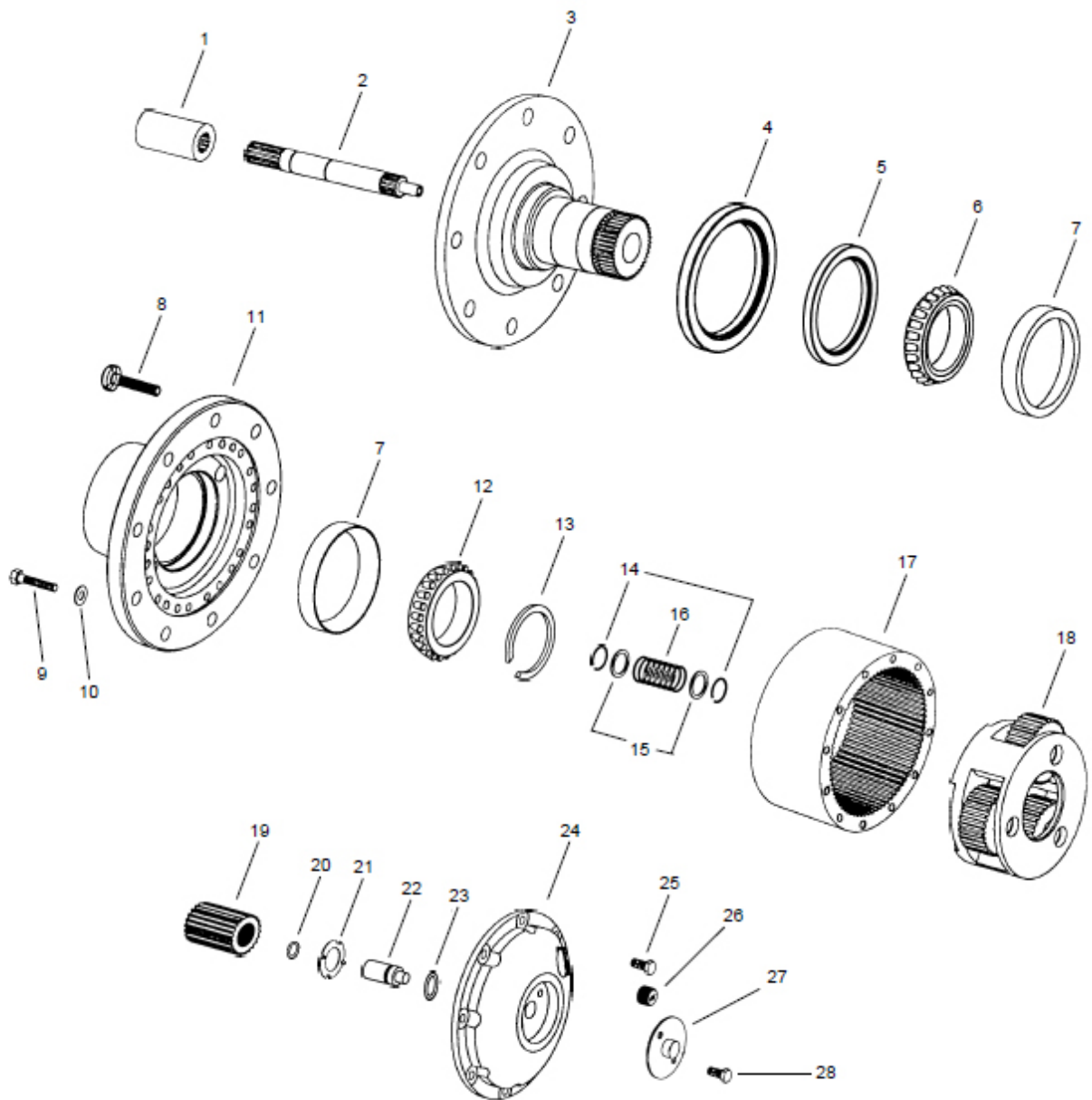

PARTS

## 30-099 AUBURN® POWER WHEEL PARTS LIST

REF#	PART#	DESCRIPTION	QUANTITY
1		Coupling	1
2		Input Shaft	1
3		Spindle	1
4 †	30-099-02	Boot Seal	1
5*†	30-099-06	Oil Seal	1
6*		Bearing Cone	1
7*		Bearing Cup	2
8		Wheel Hex Bolt	9
9		Hex Head Hex Bolt (Grade 8)	6-12
10		Flat Washer	6-12
11		Hub	1
12*		Bearing Cone	1
13*†		Retaining Ring Kit	1
14	30-099-04	Retaining Ring	2
15		Washer	2
16	30-099-03	Disengage Spring	1
17		Ring Gear	1
18		Carrier Assembly	1
19		Sun Gear	1
20		Retaining Ring	1
21	30-099-07	Thrust Washer	1
22		Disengage Plunger	1
23*†		O-ring	1
24		Large Cover	1
25		Hex Head Hex Bolt	8
26		Magnetic Plug	1
27		Disengage Cover	1
28		Hex Head Hex Bolt	2
29		Quick Disconnect Gasket	1
30		Quick Disconnect Assembly	1
31		Hex Head Hex Bolt	2
*	30-099-05	Bearing and Seal Kit	
†	30-099-01	Seal Kit	

# 3182 PLUMBING DRAWING (RADION 8140)

15-817

#50 Fitting O-ring

15-818

#75 Fitting O-ring

## 18" Boom

9032-138

3/4" Black Hose x 138" (left boom)

1

9032-96

3/4" Black Hose x 96" (center boom)

1

9032-134

3/4" Black Hose x 134" (right boom)

1

18-040

Hose Clamps

6

## 20" Boom

9032-148

3/4" Black Hose x 148" (left boom)

1

9032-96

3/4" Black Hose x 96" (center boom)

1

9032-144

3/4" Black Hose x 144" (right boom)

1

18-040

Hose Clamps

6

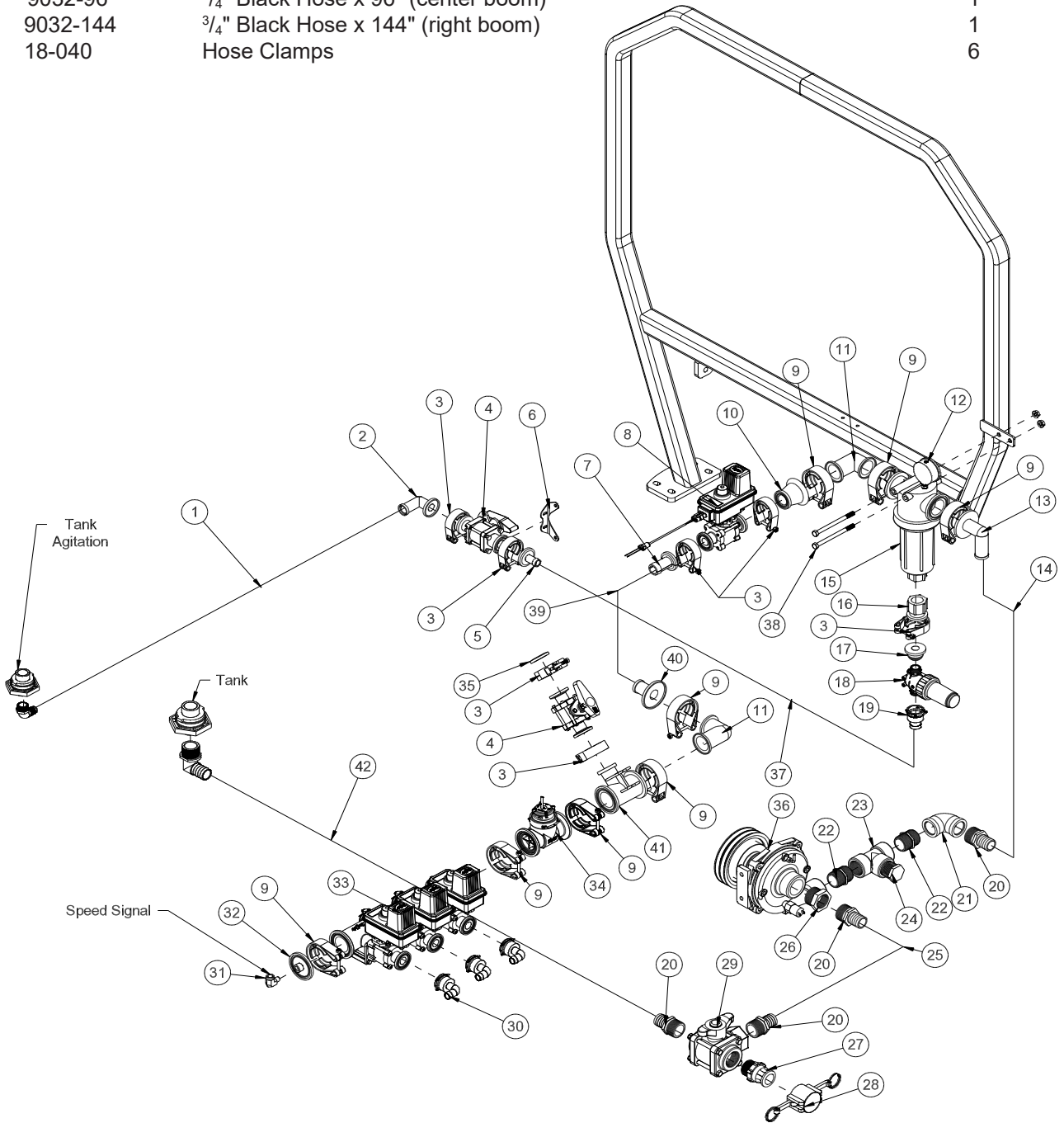

PARTS

## 3182 PLUMBING PARTS LIST (RADION® 8140)

REF#	PART#	DESCRIPTION	QUANTITY
1	8896-85	1" Discharge Hose 85"	1
	18-222	Hose Clamp	2
2	15-746	#50 - 90° Hose Barb	1
3	15-740	#50 Series Clamp	5
4	15-738	Flanged Ball Valve	2
5	15-808	#50 Straight Hose Barb	1
6	20-689	Valve Bracket	1
7	15-870	#50 1 <sup>1</sup> / <sub>4</sub> Hose Barb	1
8	20-685	Regulator Valve	1
9	15-741	#75 Series Clamp	8
10	15-748	Reducer Coupling	1
11	15-734	#75 Elbow Coupling	2
12	16-281	Liquid Filled Gauge	1
13	15-739	#75 x 90° x 1 <sup>1</sup> / <sub>2</sub> Hose Barb	1
14	8897-64	1 <sup>1</sup> / <sub>4</sub> " Discharge Hose 48"	1
	18-116	Hose Clamp	2
15	15-737	Flanged Strainer	1
	16-968-03	Screen (50 mesh)	1
16	15-735	#50 x 1 Female Pipe thread Fitting	1
17	15-825	#50 Male Quick Coupler	1
18	14-801	Agitator Line Strainer, 50 Mesh	1
	14-802	Replacement 50 Mesh Screen	
19	15-869	1" Hose Barb Outlet	1
	15-553-01	Clip	1
	15-553-02	O-ring	1
20	16-161	Fitting	4
21	16-182	90° Elbow	1
22	16-880	Nipple	2
23	18-390	Tee	1
24	10-389	Plug	1
25	8897-36	1 <sup>1</sup> / <sub>4</sub> " Discharge Hose 36"	1
	18-116	Hose Clamp	2
26	16-825	Hex Bushing	1
27	16-180	Quick Coupler Male	1
28	16-935	Quick Coupler Cap	1
29	18-372	3-Way Valve	1
	18-372-01	Handle	1
30	15-553	<sup>3</sup> / <sub>4</sub> " - 90° Hose Barb	3
	15-553-01	Clip	3
	15-553-02	O-ring	3
31	18-007	Street Elbow	1
32	15-882	#75 Gauge Port	1
33	15-743	Manifold Valve	1
34	20-684	#802 Flow Meter	1
35	15-778	Blank Gauge Port Flange	1
36	16-998	Hypro Spray Pump	1
37	8896-72	1" Discharge hose x 72"	1
	18-222	Hose Clamp	2
38	HB-38-16-500	Hex Bolt, <sup>3</sup> / <sub>8</sub> - 16 x 5	2
	HNFL-38-16	Flange Whiz-loc Nut, <sup>3</sup> / <sub>8</sub> - 16	2
39	8897-60	1 <sup>1</sup> / <sub>4</sub> " Discharge Hose x 60"	1
	18-116	Hose Clamp	2
40	15-744	#75 1 <sup>1</sup> / <sub>4</sub> Hose Barb	1
41	15-775	Reducer Tee	1
42	8897-23	1 <sup>1</sup> / <sub>4</sub> " Discharge Hose x 23"	1
	18-116	Hose Clamp	2



# 3184 PLUMBING DRAWING (TEEJET 744®)

- 15-817 #50 Fitting O-ring
- 15-818 #75 Fitting O-ring

## 18" BOOM

- 9032-138 3/4" Black Hose x 138" (left boom) 1
- 9032-96 3/4" Black Hose x 96" (center boom) 1
- 9032-134 3/4" Black Hose x 134" (right boom) 1
- 18-040 Hose Clamps 6

## 20" BOOM

- 9032-148 3/4" Black Hose x 148" (left boom) 1
- 9032-96 3/4" Black Hose x 96" (center boom) 1
- 9032-144 3/4" Black Hose x 144" (right boom) 1
- 18-040 Hose Clamps 6

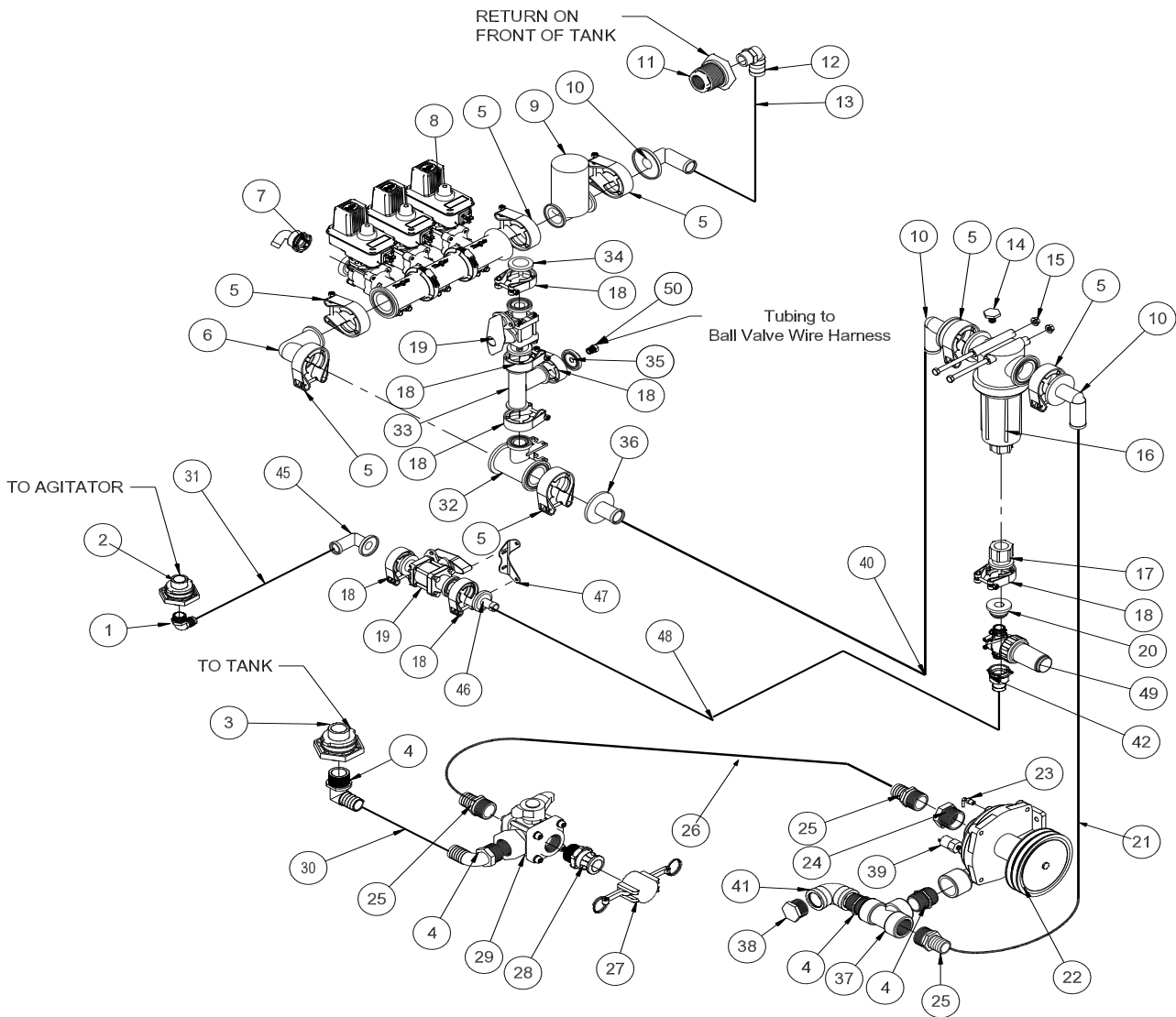

ACCESSORIES

# 3184 PLUMBING PARTS LIST (TEEJET 744®)

REF#	PART#	DESCRIPTION	QUANTITY
1	16-155	Elbow	1
2	16-150	Double Threaded Fitting	1
3	16-194	Anti-Vortex Fitting	1
4	16-880	Nipple	3
5	15-741	#75 Series Clamp	7
6	15-734	#75 Elbow Coupling	1
7	15-553	3/4 - 90° Hose Barb	3
	15-553-01	Clip	3
	15-553-02	O-ring	3
8	15-743	Manifold Valve	1
9	16-524	Motorized Control Valve	1
10	15-739	#75 x 90° x 1 1/2 Hose Barb	3
11	16-945	Double Threaded Fitting	1
12	15-779	Hose Barb	1
13	8897-44	1 1/4" Discharge Hose x 44"	1
	18-116	Hose Clamp	2
14	15-780	1/4" Poly Hex Plug	1
15	HB-38-16-500	Hex Bolt, 3/8 - 16 x 5	2
	HNFL-38-16	Flange Whiz-loc Nut, 3/8 - 16	2
16	15-737	Flanged Strainer	1
	16-968-03	Screen (50 mesh)	1
17	15-735	#50 x 1 Female Pipe thread Fitting	1
18	15-740	#50 Series Clamp	5
19	15-738	Flanged Ball Valve	2
20	15-825	#50 Male Quick Coupler	1
21	8897-64	1 1/4" Discharge Hose x 64"	1
	18-116	Hose Clamp	2
22	16-998	Hypro Spray Pump	1
23	18-475	Male Elbow	1
	9038-30	Tubing	1
24	16-825	Hex Bushing	1
25	16-161	Fitting	3
26	8897-24	1 1/4" Discharge Hose x 24"	1
	18-116	Hose Clamp	2
27	16-935	Quick Coupler Cap	1
28	16-180	Quick Coupler Male	1
29	18-372	3-Way Valve	1
	18-372-01	Handle	1
30	8897-36	1 1/4" Discharge Hose x 36"	1
	18-116	Hose Clamp	2
31	8896-85	1" Discharge Hose x 85"	1
	18-222	Hose Clamp	2
32	15-775	Reducer Tee	1
33	15-776	#50 Series Tee	1
34	15-778	Blank Gauge Port Flange	1
35	15-777	Gauge Port Flange	1
36	15-744	#75 1 1/4 Hose Barb	1
37	18-390	Tee	1
38	10-389	Plug	1
39	33-480	Pressure Switch	1
40	8897-60	1 1/4" Discharge Hose x 60"	1
	18-116	Hose Clamp	2
41	16-182	90° Elbow	1
42	15-869	1" Hose Barb Outlet	1
	15-553-01	Clip	1
	15-553-02	O-ring	1
45	15-746	#50 - 90° Hose Barb	1
46	15-808	#50 Straight Hose Barb	1
47	20-689	Valve Bracket	1
48	8896-72	1" Discharge Hose x 72"	1
	18-222	Hose Clamp	2
49	14-801	Agitator Line Strainer, 50 Mesh	1
	14-802	Replacement 50 Mesh Screen	
50	18-042	Reducer Bushing	1

# 3185/3186/3187/3188 PLUMBING DRAWING

DynaJet® Plumbing Drawing (for Aeros® 9040 or radion® 8140)

## 18" BOOM

9032-138	3/4" Black Hose x 138" (left boom)	1
9032-96	3/4" Black Hose x 96" (center boom)	1
9032-134	3/4" Black Hose x 134" (right boom)	1
18-040	Hose Clamps	6

## 20" BOOM

9032-148	3/4" Black Hose x 148" (left boom)	1
9032-96	3/4" Black Hose x 96" (center boom)	1
9032-144	3/4" Black Hose x 144" (right boom)	1
18-040	Hose Clamps	6

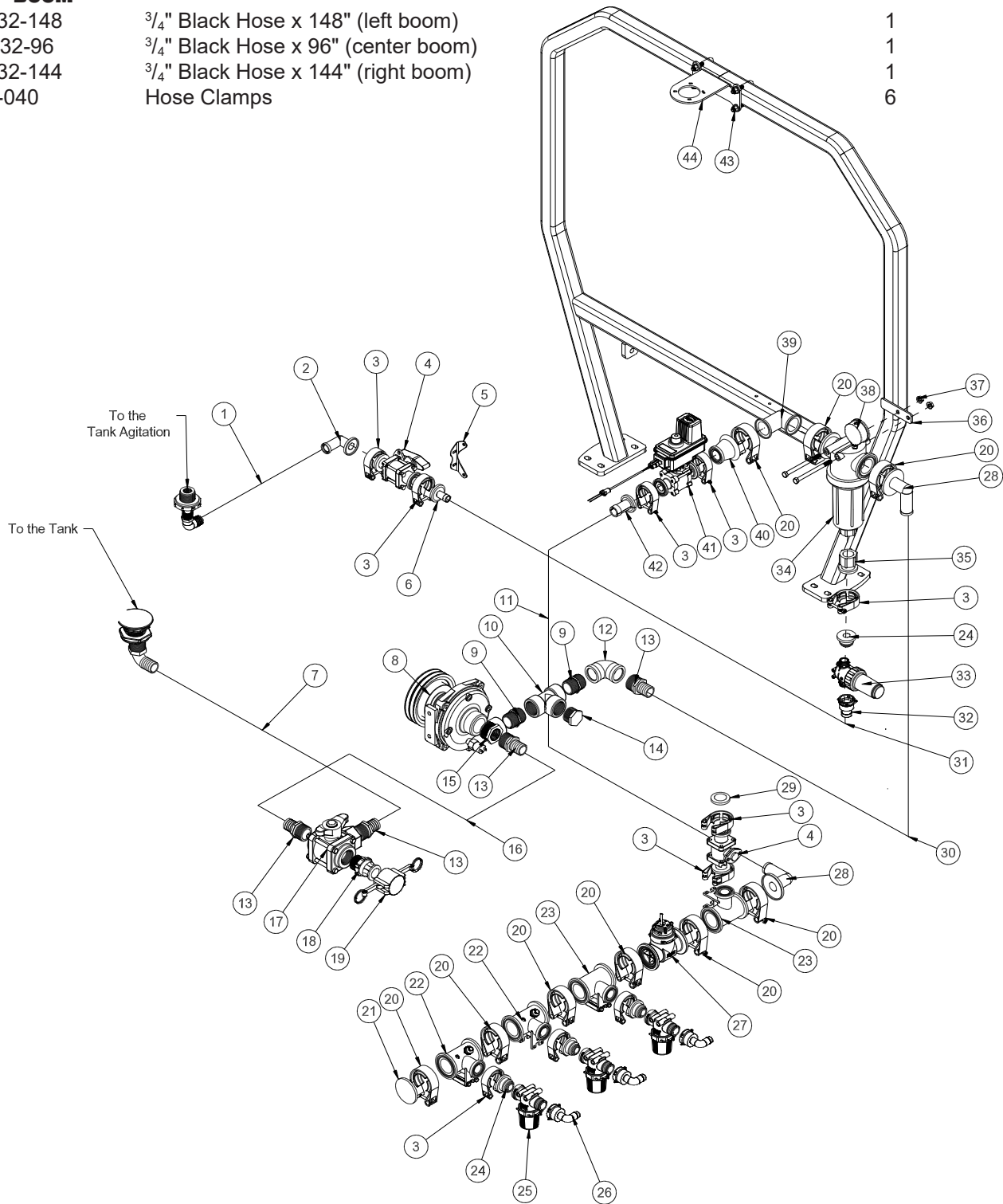

ACCESSORIES

## 3185/3186/3187/3188 PLUMBING PARTS LIST

REF#	PART#	DESCRIPTION	QUANTITY
1	8896-85	1" Discharge Hose x 85"	1
	18-222	Hose Clamp	2
2	15-746	#50 90° Hose Barb	1
3	15-740	#50 Series Clamp	10
4	15-738	Flanged Ball Valve	2
5	20-689	Valve Bracket	1
6	15-808	#50 Straight Hose Barb	1
7	8897-24	1 1/4" Discharge Hose x 24"	1
	18-116	Hose Clamp	2
8	16-998	Hypro® Pump	1
9	16-880	Nipple	2
10	18-390	Tee	1
11	8897-66	1 1/4" Discharge Hose x 66"	1
	18-116	Hose Clamp	2
12	16-182	90° Elbow	1
13	16-161	Fitting	4
14	10-389	Plug	1
15	16-825	Hex Bushing	1
16	8897-36	Discharge Hose	1
	18-116	Hose Clamp	2
17	18-372	3-Way Valve	1
18	16-180	Quick Coupler Male	1
19	16-935	Quick Coupler Cap	1
20	15-741	#75 Series Clamp	8
21	15-742	#75 Inlet Cover	1
22	30-164	Tapped Reducer Tee	2
	15-743-03	Mounting Rail	2
	15-743-06	SS Screw	8
23	15-775	Reducer Tee	2
24	15-825	QC Flange Adapter	3
25	14-607	QC Strainer, 100Mesh	3
26	15-553	3/4" - 90° Hose Barb	3
27	20-684	#802 Flow Meter	1
28	15-739	#75 90° Hose Barb	2
29	15-778	Blank Gauge Port Flange	1
30	8897-64	1 1/4" Discharge Hose x 64"	1
	18-116	Hose Clamp	2
31	8896-72	1" Discharge Hose x 72"	1
	18-222	Hose Clamp	2
32	15-869	1" Hose Barb Outlet	1
	15-553-01	Clip	1
	15-553-02	O-ring	1
33	14-801	Agitator Line Strainer, 50 Mesh	1
	14-802	Replacement 50 Mesh Screen	
34	14-628	Flanged Strainer with 80 Mesh Screen	1
35	15-735	#50 x 1 FTP Fitting	1
36	31-063	ROPs	1
37	HB-38-16-550	Hex Bolt, 3/8 - 16 x 5 1/2	2
	HNFL-38-16	Flange Whiz-loc Nut, 3/8 - 16	2
38	16-281	Liquid Filled Gauge	1
39	15-734	#75 Elbow Coupling	1
40	15-748	Reducer Coupling	1
41	20-685	Regulator Valve	1
42	15-870	#50 1 1/4 Hose Barb	1
43	17-537	Square U-Hex Bolt (AEROS Only)	2
44	20-770	GNS Antenna Mount (Aeros Only)	1
15-817	#50 Fitting O-ring		
15-818	#75 Fitting O-ring		

# DYNAJET® MODULE MOUNTS

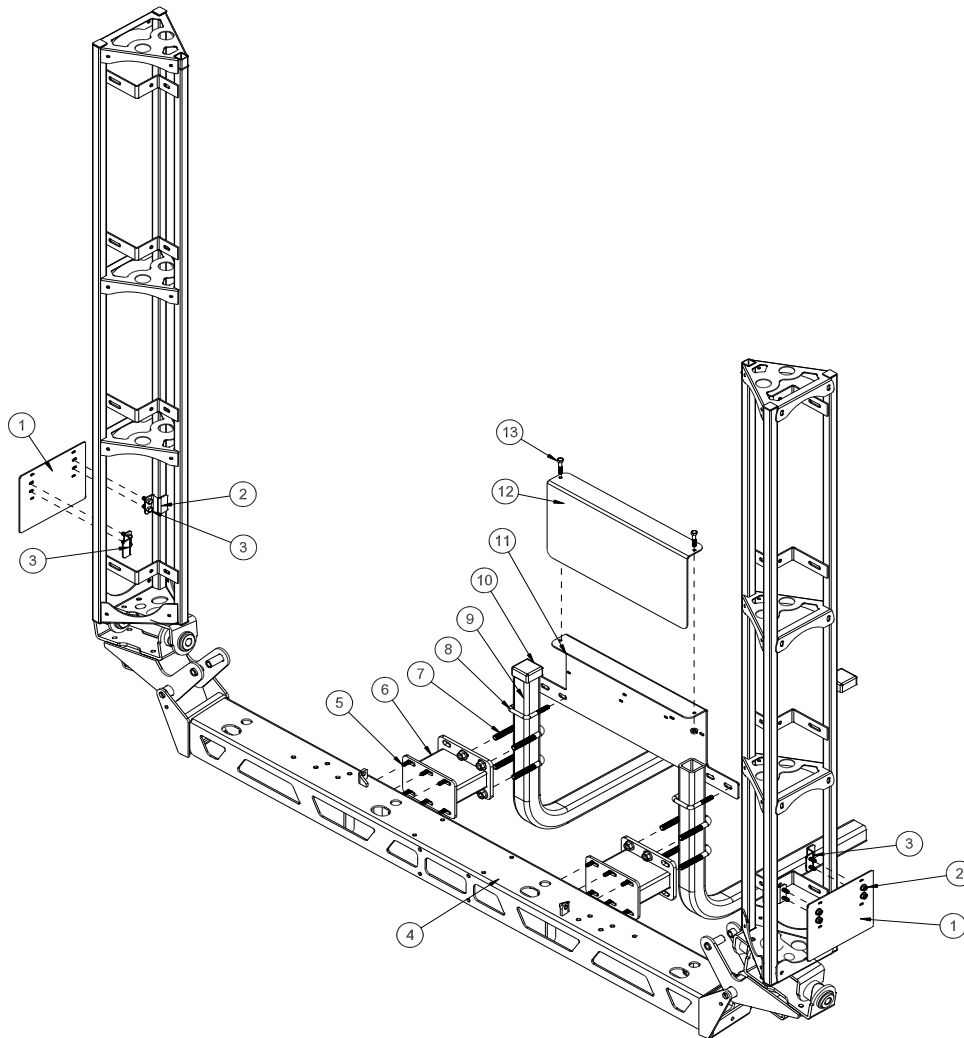

REF#	PART#	DESCRIPTION	QUANTITY
1	20-665	Drive Module Bracket	2
2	20-664	Z Bracket	4
3	HSTP-14-20-075	Machine Screw, $\frac{1}{4}$ - 20 x $\frac{3}{4}$	10
	HNFL-14-20	Flange Whiz-loc Nut, $\frac{1}{4}$ - 2	10
4		Center Boom Mount	1
5	HB-516-18-100	Hex Bolt, $\frac{5}{16}$ - 18 x 1	12
6	17-614	Boom Spacer	2
	HNTL-516-18	Nylon Lock Nut, $\frac{5}{16}$ - 18	12
7	20-555	U-Hex Bolt	4
	HNFL-12-13	Flange Whiz-loc Nut, $\frac{1}{2}$ - 13	8
8	17-537	Square U-Hex Bolt	2
9	17-615	Boom Carrier	2
10	16-557	Square Cap	2
11	20-667	Module Mount Bracket	1
12	20-666	Module Cover Bracket	1
13	HB-516-18-150	Hex Bolt, $\frac{5}{16}$ - 18 x $1\frac{1}{2}$	2
	HNFL-516-18	Flange Whiz-loc Nut, $\frac{5}{16}$ - 18	2

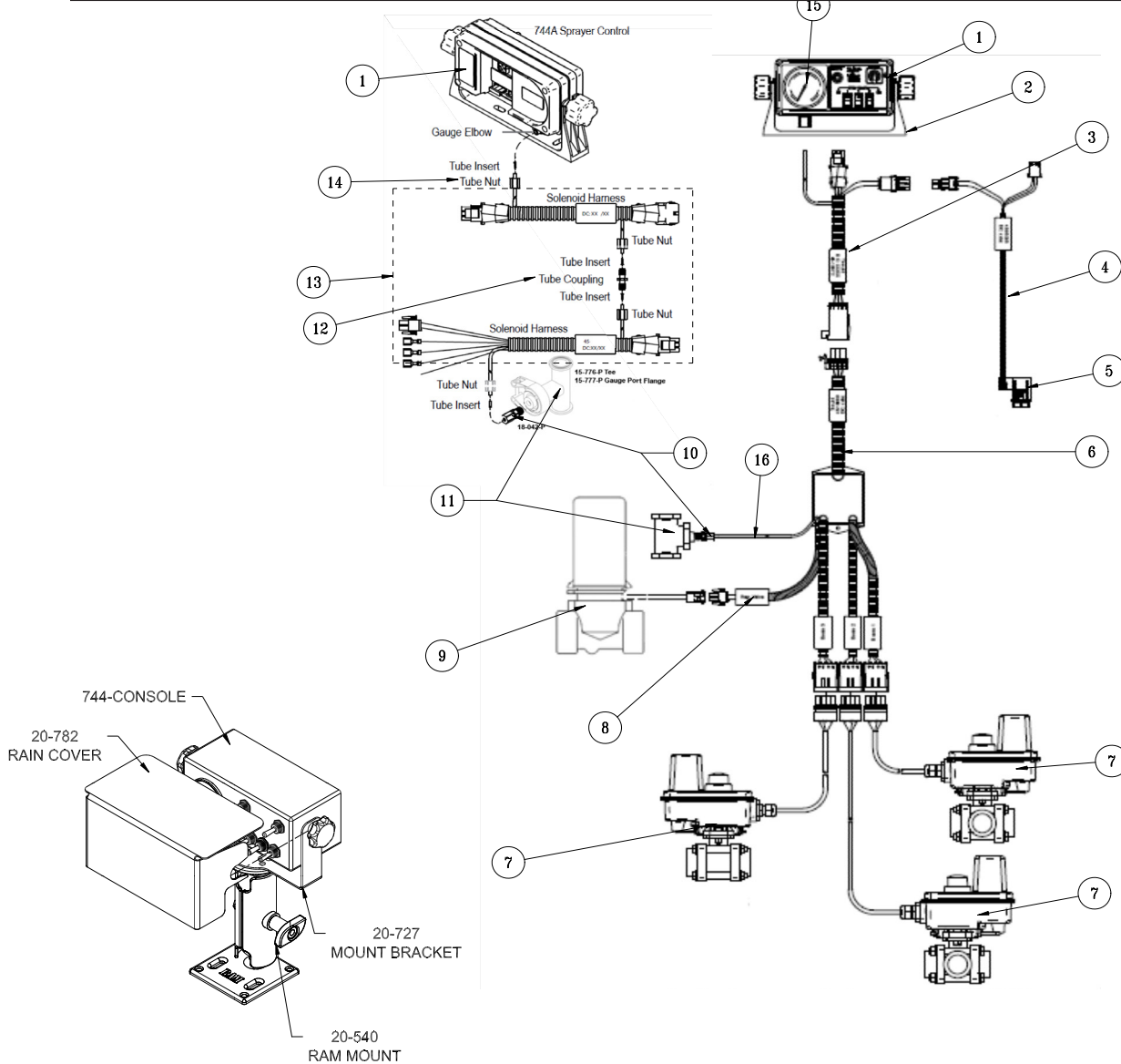

REF#	PART#	DESCRIPTION	QUANTITY
1*	20-688-02	744A Console	1
2	20-727	Mount Bracket	1
	20-540	Ram Mount	1
3*		Console harness	1
4*		Fused Power Cable	1
5	33-271	Fuse Block	1
6*		Ball Valve Wire Harness	1
7	15-743	Manifold Ball Valve	1
8*		Regulator Valve Adapter	1
9	16-524	Regulating Valve	1
10	18-042	Reducer Bushing	1
11	15-776	Tee, 50 Series	1
	15-777	Gauge Port Flange	1
12*	20-688-05	Tube Coupling	1
13*		Tube Nut Kit	1
14*	20-688-06	Tube Nut	1
15*	20-688-01	100PSI Liquid Gauge	1
16*	20-688-04	Tubing	1
*	20-688	744A Kit Complete (includes * items)	

# 3182 SYSTEM WIRING (RADION 8140)

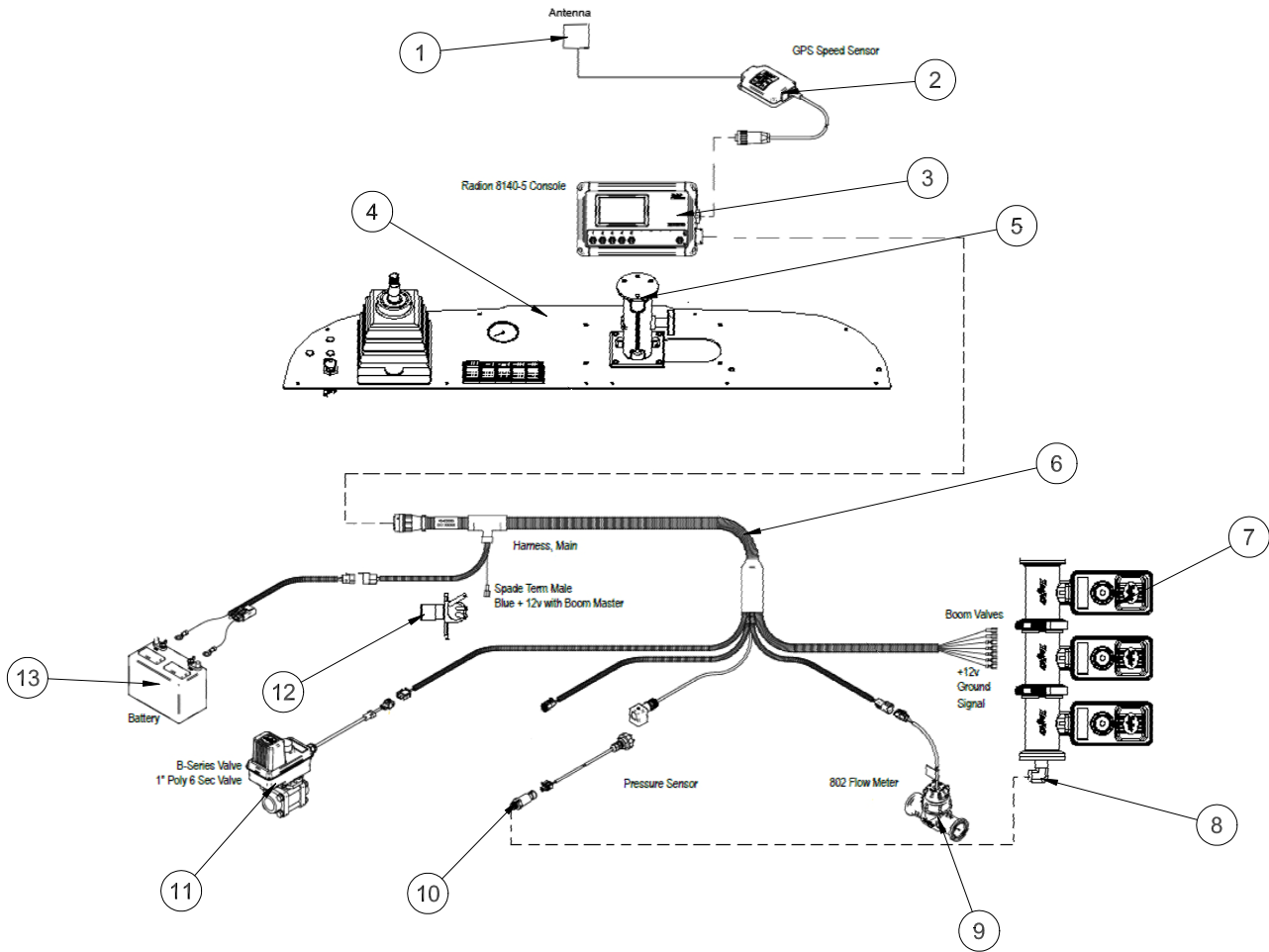

## **⚠ IMPORTANT**

If using Simulated Speed with a Radion 8140, one needs to change back to Ground Speed for proper rate control when spraying.

REF#	PART#	DESCRIPTION	QUANTITY
1*		Antenna	1
2*		GPS Speed Sensor	1
3*	20-697-01	Radion 8140 Console	1
	20-781	Plastic Console Cover	1
4	20-734	Dashboard	1
5	20-540	Ram Mount	1
6*		Wire Harness	1
7	15-743	Manifold Valve	1
8	18-007	Elbow	1
9	20-684	Flow Meter	1
10*	20-670-04	Pressure Sensor	1
11	20-685	Regulator Valve	1
12	33-509	Master Boom Control	1
13	33-216	Battery	1
*	20-697	TeeJet® Radion Kit (includes * items)	1

Use Dielectric Grease On All Electrical Connections

20-767 RX720 RECEIVER  
20-736-01 COM 1 CABLE

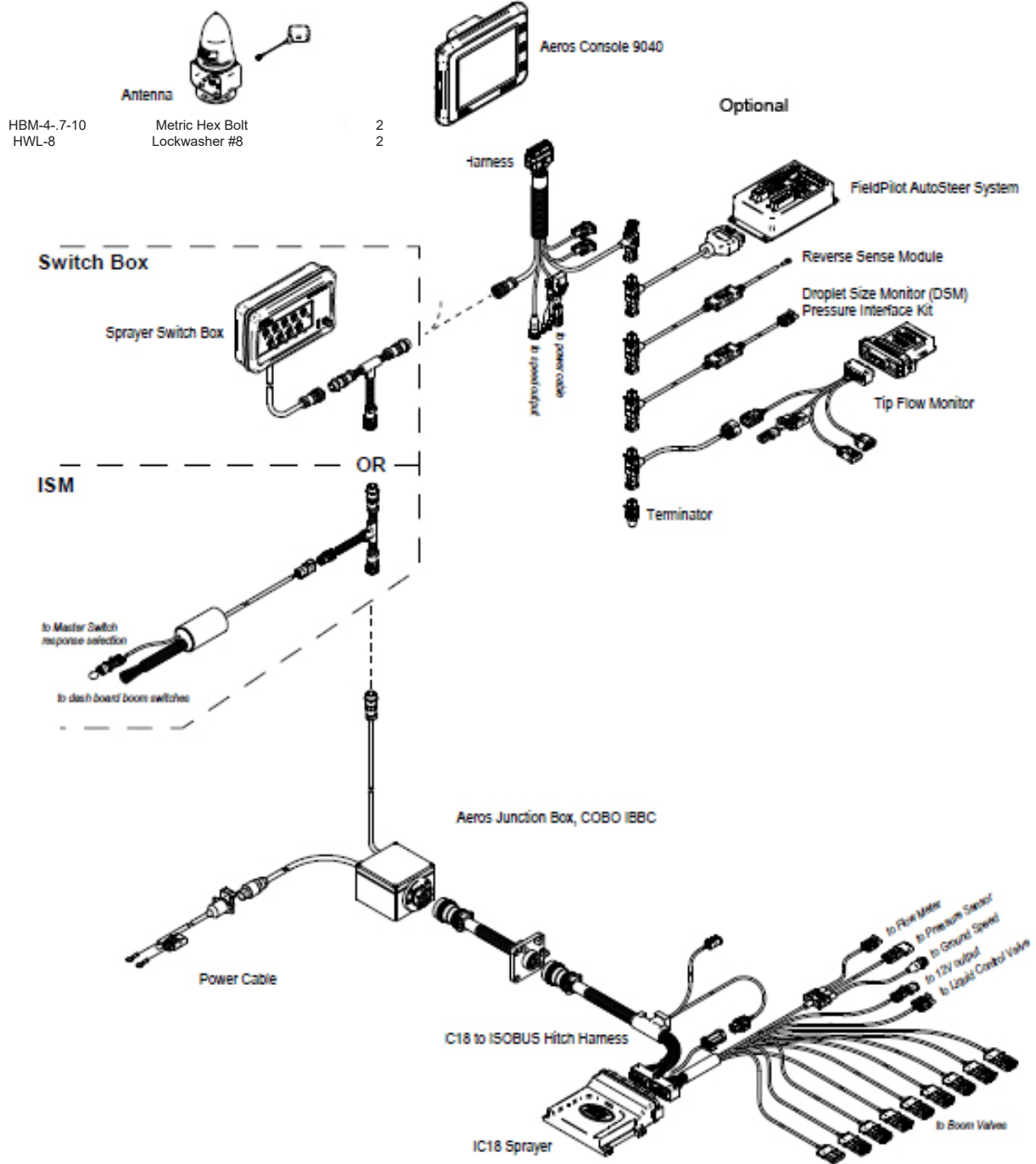

Accessories

# 3185/3186/3187/3188 WIRING TEEJET® DYNA JET SYSTEM

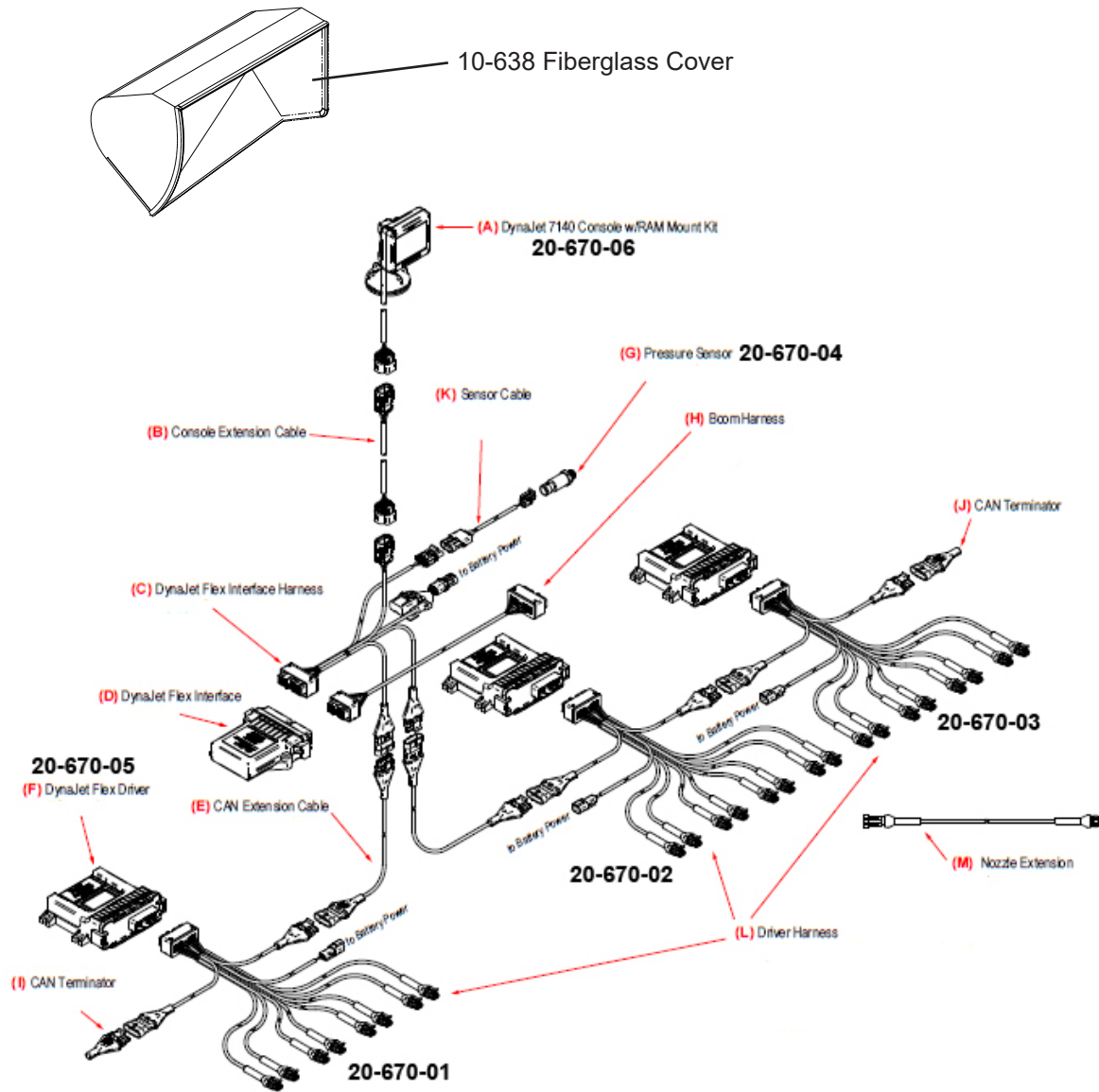

# 16-524 MOTORIZED CONTROL VALVE DRAWING

## WHEN SERVICING VALVE:

- Replace valve body with ISO-Body Kit if valve has been leaking internally.
- Replace motor assembly if the motor will not run.
- Before reassembling valve, remove the coupler shaft from the valve body. Apply Loctite to coupler shaft and woodruff key. Place the coupler shaft (Ref 5) and the woodruff key (Ref 4) onto the motor shaft. Plug motor into the valve connector coming from Sprayer Control Console. Check that the motor rotates in both directions. Motor must stop when coupler shaft CAM releases printed circuit board button
- When reassembling valve, grease both sealing surfaces of coupler shaft. Insert coupler shaft into Iso-flange and be sure seal properly seats on shaft. Install motor on valve body and apply silicon sealant to mounting holes. Reassemble remaining items as shown in parts diagram.

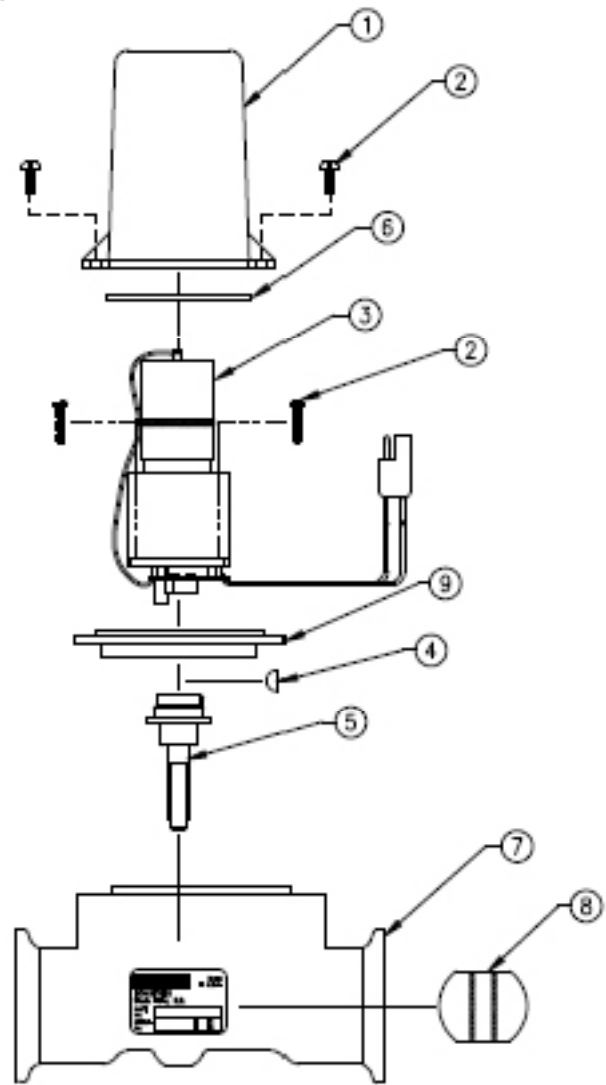

REF#	PART#	DESCRIPTION	QUANTITY
1	16-870	Valve Cover	1
2*	16-524-01	#6 Self Tapping Screw $\frac{3}{4}$ " Long	6
3	16-875	Motor Assembly	1
4*	16-957	Woodruff Key	1
5*	16-524-02	Coupler Shaft	1
6*	16-897	Seal Tetraseal	1
7*	16-524-06	Valve Body Assembly 1"	1
8*	16-956	Butterfly	1
9*	16-524-04	Isolation Flange Assembly	1
*	16-524-05	1" Valve ISO-Body Kit	

# 20-685 REGULATOR VALVE

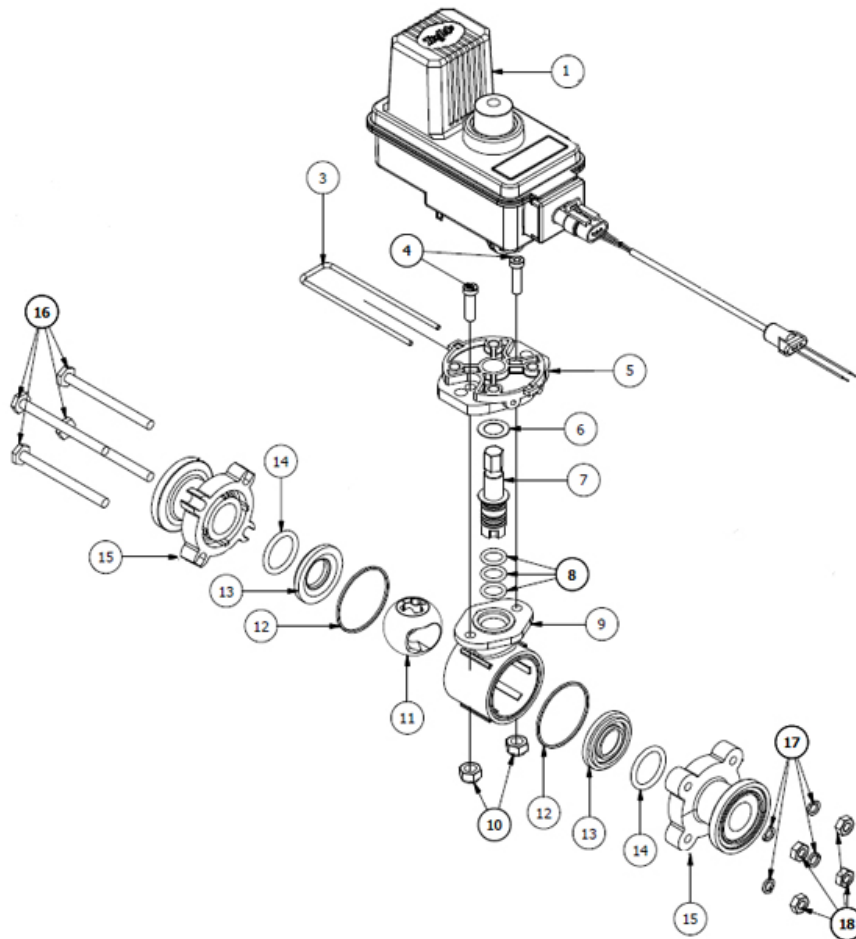

REF#	PART#	DESCRIPTION	QUANTITY
1	20-685-01	Motor	
3	15-552-24	Retaining Clip	1
4	15-552-25	Socket Head Cap Screw, Stainless Steel	2
5	15-552-26	Motor Adapter, Polypropylene	1
6	15-517-11	Thrust Washer, Teflon	1
7	15-552-27	Stem, Stainless Steel	1
8*	15-552-05	O-ring, Viton	3
9	15-517-16	Body, Nylon	1
10		Lock Nut, Stainless Steel	2
11		Ball, Polypropylene	1
12	15-552-13	Gasket, Viton	2
13	15-517-19	Seal, Teflon	2
14	15-517-20	O-ring, Viton	2
15	15-743-01	End Cap	1
16		SS Hex Bolt, 1/4 - 20 x 3	4
17		SS Lock Washer, 1/4	4
18		SS Nut, 1/4 - 20	4
	20-685	Complete Regulator Valve	

# 15-743 MANIFOLD BALL VALVE

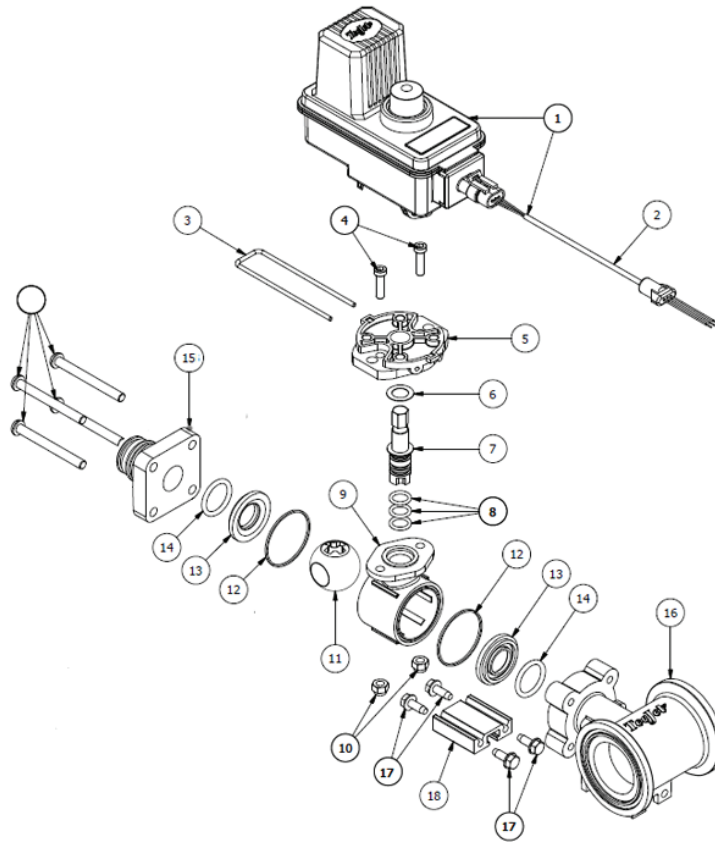

REF#	PART#	DESCRIPTION	QUANTITY
1	15-552-23	Motor	
2	15-878	Metri-Pack Cable (comes with motor)	1
3	15-552-24	Retaining Clip	1
4	15-552-25	Socket Head Cap Screw, Stainless Steel	2
5	15-552-26	Motor Adapter, Polypropylene	1
6*	15-517-11	Thrust Washer, Teflon	1
7	15-552-27	Stem, Stainless Steel	1
8*	15-552-05	O-ring, Viton	3
9	15-517-16	Body, Nylon	1
10		Lock Nut, Stainless Steel	2
11	15-743-04	Ball, Polypropylene	1
12*	15-552-13	Gasket, Viton	2
13*	15-517-19	Seal, Teflon	2
14*	15-517-20	O-ring, Viton	2
15	15-743-01	End Cap	1
16	15-743-02	#75 Tee Body	1
17	15-743-06	Screw, SS	4
18	15-743-03	Mounting Rail Aluminum	1
* 15-552-10 15-743-05		Spare Parts Kit (includes all * items) Single Valve (shown)	

# 15-737/14-628 FLANGED STRAINER

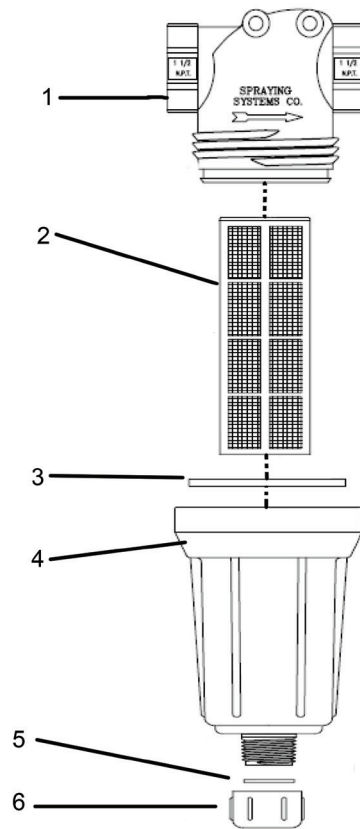

REF#	PART#	DESCRIPTION	QUANTITY
1	15-737-01	Strainer Head 75 Series	1
2*	16-968-03	50 Mesh Strainer	1
**	16-968-05	80 Mesh Strainer	1
3	14-521-02	EPDM Gasket	1
4	14-521-03	Bowl 1" NPT	1
5	14-521-04	EPDM Rubber gasket	1
6	14-521-05	Cap	1

\* 15-737 Flanged Strainer Assembly with 50 Mesh Screen

# 14-801 FLANGED STRAINER ASSEMBLY WITH 80 MESH

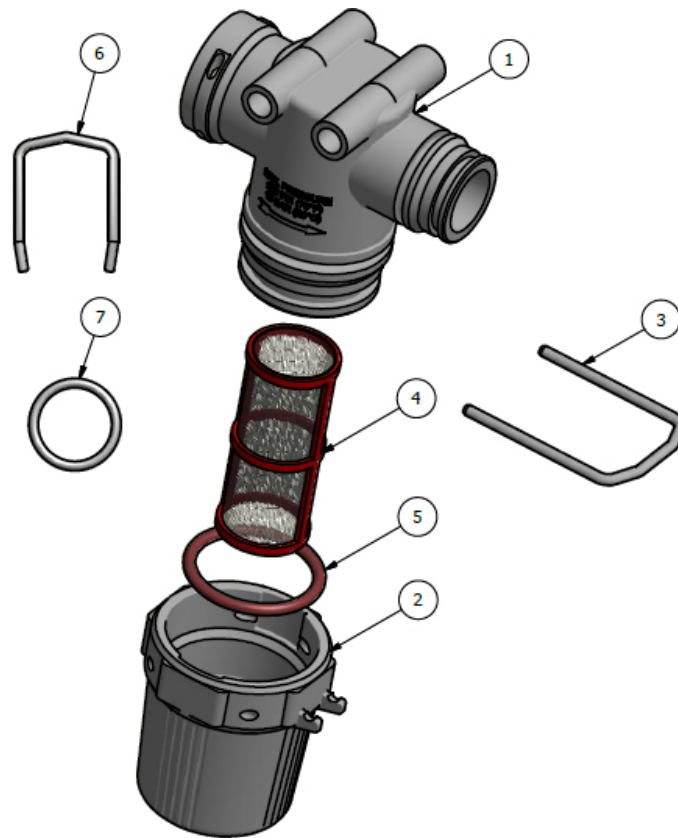

REF#	PART#	DESCRIPTION	QUANTITY
1		QC Strainer Head	1
2		Bowl	1
3		Strainer QC Retaining Clip	1
4	14-802	50 Mesh Strainer	1
5		Viton Oring	1
6	15-553-01	Retaining Clip	1
7	15-553-02	Viton Oring	1

# 17-580 20' HEAVY BOOM

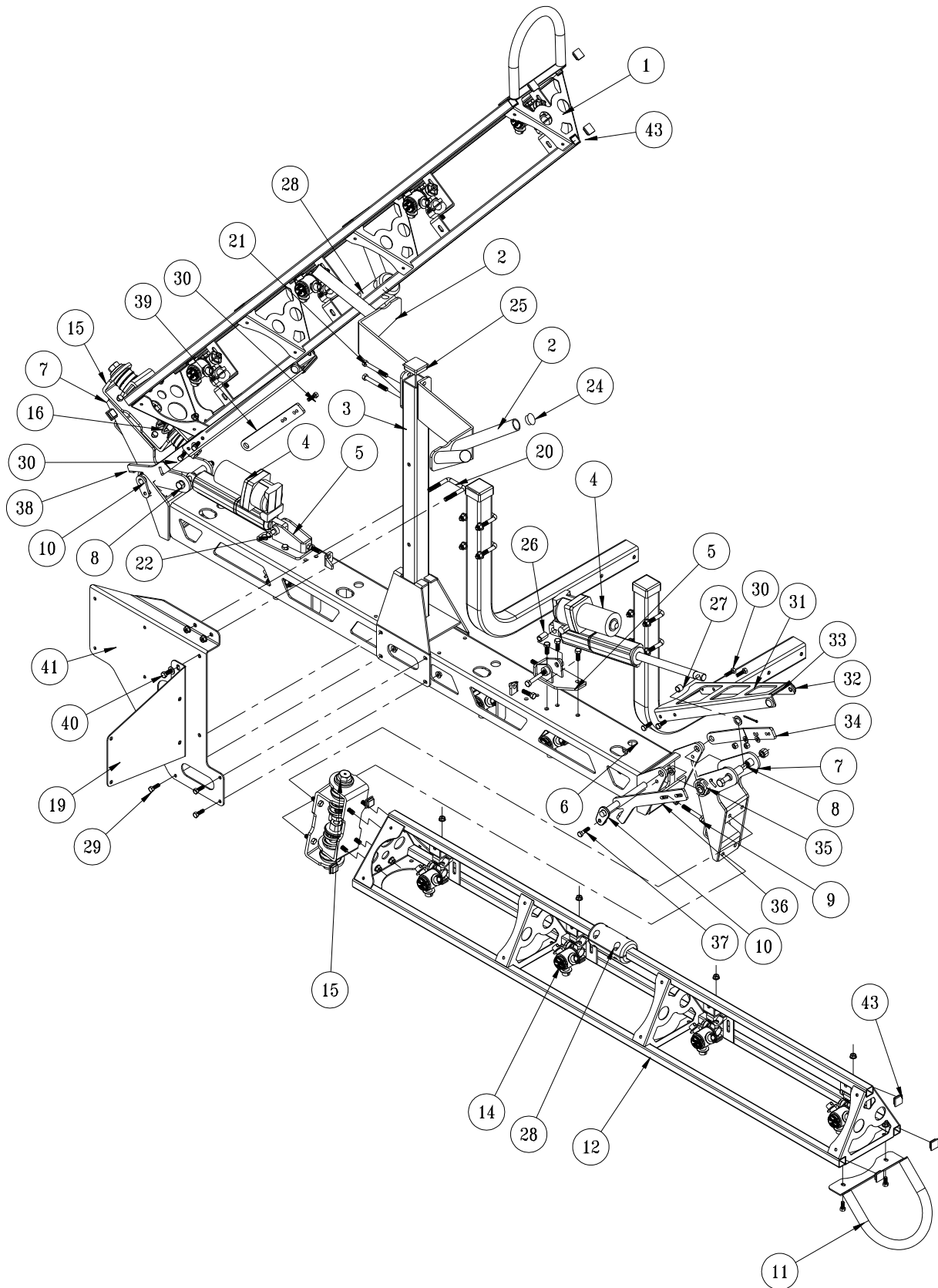

Accessories

# 17-580 20' HEAVY BOOM

REF#	PART#	DESCRIPTION	QUANTITY
1	17-531	Left Boom Arm	1
2	17-631	V-Boom Nest	2
3	17-578	Boom Nest Post	1
4	30-214	10" Electric Hydraulic Actuator	2
5	30-184	Actuator Mount	2
	HN-38-16	Hex Nut, $\frac{3}{8}$ - 16 (adjustment Hex Bolt)	4
	HB-38-16-100	Hex Bolt, $\frac{3}{8}$ - 16 x 1	6
	HW-38	Flat Washer, $\frac{3}{8}$	6
	HNFL-38-16	Flange Whiz-loc Nut, $\frac{3}{8}$ -16	6
6	17-579	Boom Center	1
7	30-185	Arm Pivot Hinge	2
	HG-14-28-180	Grease Fitting, $\frac{1}{4}$ - 28 x 180°	2
	76-128	Bushing	4
8	HB-12-13-500	Hex Bolt, $\frac{1}{2}$ - 13 x 5	2
	HNTL-12-13	Nylon Lock Nut, $\frac{1}{2}$ - 13	2
9	HB-38-16-175	Hex Bolt, $\frac{3}{8}$ - 16 x $1\frac{3}{4}$	2
	HNFL-38-16	Flange Whiz-loc Nut, $\frac{3}{8}$ -16	4
10	17-596	Hinge Pin w/Spacer	2
	HP-18-100	Cotter Pin, $\frac{1}{8}$ x 1	2
11	17-541	Boom End Guard	2
	HBFL-516-18-075	Flange Whiz-loc Bolt, $\frac{5}{16}$ - 18 x $\frac{3}{4}$	4
	HNFL-516-18	Flange Whiz-loc Nut, $\frac{5}{16}$ - 18	4
12	17-532	Right Boom Arm	1
14	33-506	Body (see nozzle drawing)	12
	HB-516-18-075	Hex Bolt, $\frac{5}{16}$ -18 x $\frac{3}{4}$	12
	HNTL-516-18	Nylon Lock Nut, $\frac{5}{16}$ -18	12
15	17-632	Boom Hinge Complete	2
	HB-38-16-100	Hex Bolt, $\frac{3}{8}$ - 16 x 1	16
	HNFL-38-16	Flange Whiz-loc Nut, $\frac{3}{8}$ - 16	16
19	17-636	Fresh Water Tank Mount	1
20	17-537	Square U-Hex Bolt	1
21	HB-38-16-300	Hex Bolt, $\frac{3}{8}$ - 16 x 3	2
	HNTL-38-16	Nylon Lock Nut, $\frac{3}{8}$ - 16	2
22	HB-12-13-300	Hex Bolt, $\frac{1}{2}$ - 13 x 3	2
	HNTL-12-13	Nylon Lock Nut, $\frac{1}{2}$ - 13	2
24	17-619	Push in Plug	4
25	18-297	Cap Plug	1
26	18-036	1" Bushing (part of 30-214)	2
27	18-234	$\frac{1}{2}$ " Bushing (part of 30-214)	2
28	17-573	Guide Block Set	2
	HB-14-20-125	Hex Bolt, $\frac{1}{4}$ -20 x $1\frac{1}{4}$	8
	HNTL-14-20	Nylon Lock Nut, $\frac{1}{4}$ - 20	8
29	HB-516-18-075	Hex Bolt, $\frac{5}{16}$ - 18 x $\frac{3}{4}$	8
	HW-516	Flat Washer, $\frac{5}{16}$	8
	HNFL-516-18	Flange Whiz-loc Nut, $\frac{5}{16}$ - 18	8
30	HB-516-18-100	Hex Bolt, $\frac{5}{16}$ -16 x 1	8
	HW-516	Flat Washer, $\frac{5}{16}$	4
	HNTL-516-18	Nylon Lock Nut, $\frac{5}{16}$ - 18	8

(Continue on next page)

# 17-580 20' BOOM DRAWING

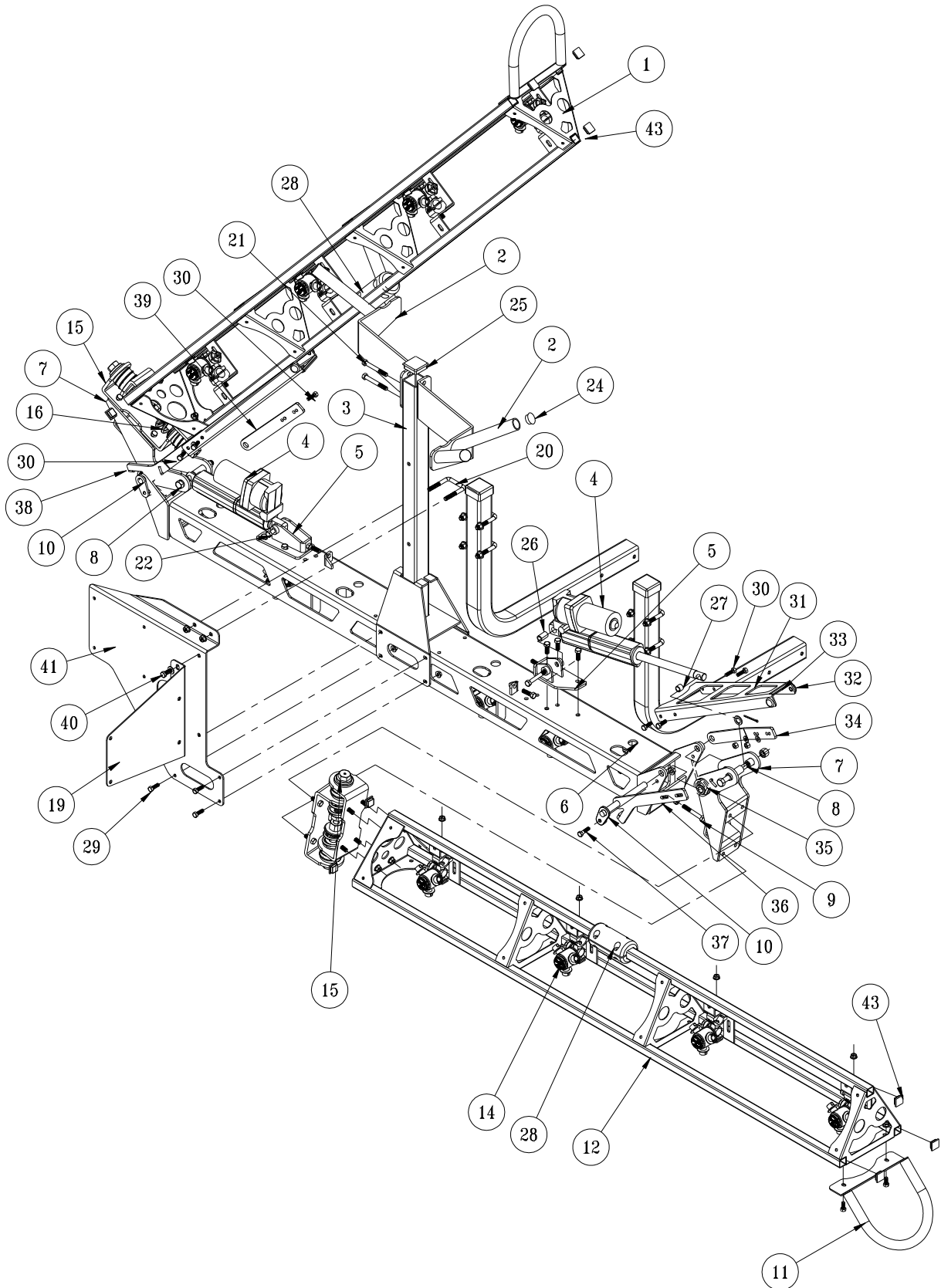

Accessories

## 17-580 20' BOOM PARTS LIST

REF#	PART#	DESCRIPTION	QUANTITY
31	17-587	Boom Lock	2
32	42-116	Rubber Insert	4
33	8803-2.75	Trim Lace, 2 <sup>3</sup> / <sub>4</sub>	2
34	17-588	Lock Hinge, RH	1
35	17-597	Torsion Spring, RH	1
36	17-589	Limit Hinge, RH	1
37	HB-516-18-100	Hex Bolt, <sup>5</sup> / <sub>16</sub> -16 x 1	2
	HNFL-516-18	Flange Whiz-loc Nut, <sup>5</sup> / <sub>16</sub> - 18	2
38	17-593	Limit Hinge, LH	1
	17-598	Torsion Spring, LH	1
39	17-592	Lock Hinge, LH	1
40	HB-38-16-100	Hex Bolt, <sup>3</sup> / <sub>8</sub> - 16 x 1	2
	HNFL-38-16	Flange Whiz-loc Nut, <sup>3</sup> / <sub>8</sub> - 16	2
	HW-38	Flat Washer, <sup>3</sup> / <sub>8</sub>	2
41	17-635	Clean Load Mount	1
	8803-13	Black Trim, 13"	1
43	30-258	1" 10-14ga Ribbed Plug	10

## BOOM MOUNT TO TRUCK

REF#	PART#	DESCRIPTION	QUANTITY
A		Center Boom Mount	1
B	17-614	Boom Spacer	2
C	HB-516-18-100	Hex Bolt, <sup>5</sup> / <sub>16</sub> -18 x 1	12
	HNTL-516-18	Nylon Lock Nut, <sup>5</sup> / <sub>16</sub> -18	12
D	20-555	U-Hex Bolt	4
	HNFL-12-13	Flange Whiz-loc Nut, <sup>1</sup> / <sub>2</sub> - 13	8

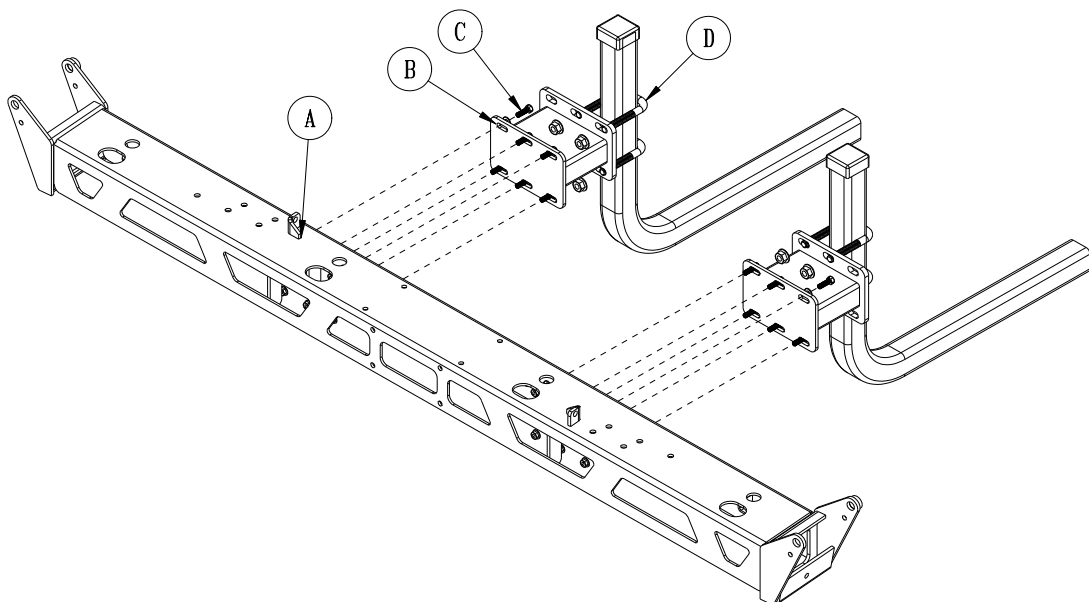

# 17-580 20' HD SUPER BOOM PLUMBING

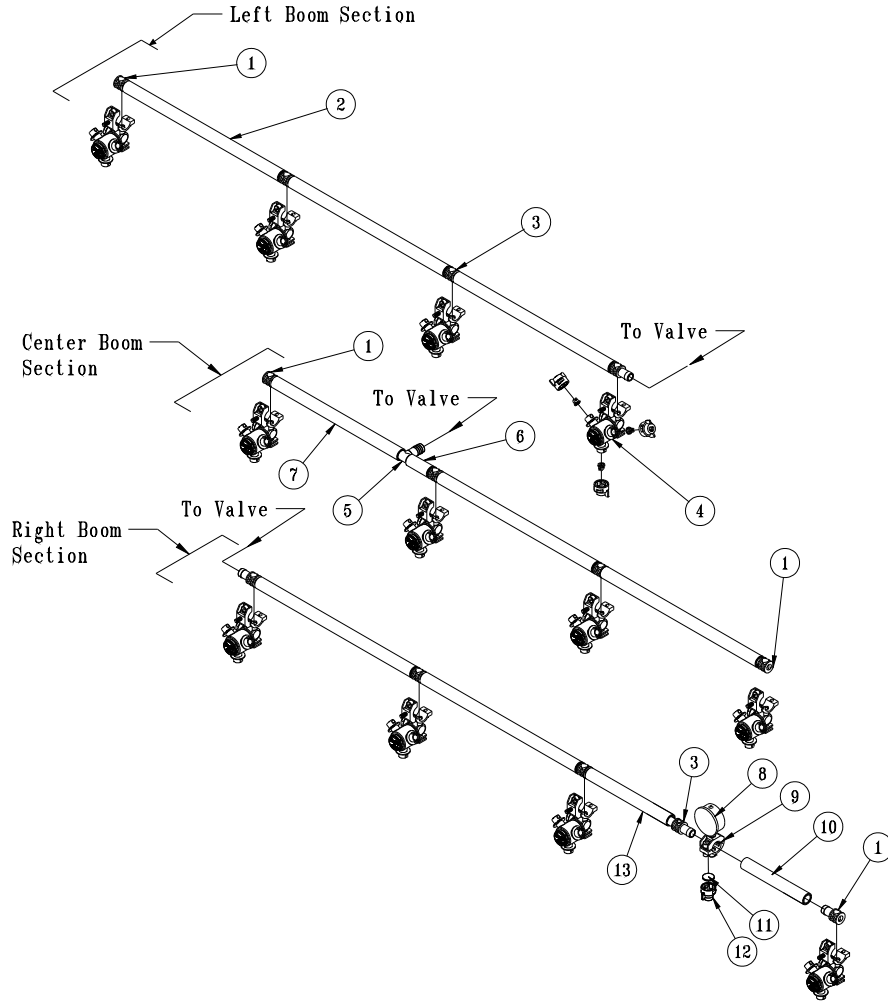

REF#	PART#	DESCRIPTION	QUANTITY
1	18-417	Single Barb	4
2	9032-19	Black Hose, 3/4" x 19"	7
	18-040	Hose Clamp	14
3	18-416	Double Barb	9
4	33-506	Nozzle body (see nozzle drawing)	12
5	18-415	3/4" Hose Barb	1
6	9032-2.5	Black Hose 3/4" x 2 1/2"	1
	18-040	Hose Clamp	2
7	9032-15.5	Black Hose 3/4" x 15 1/2"	1
	18-040	Hose Clamp	2
8	16-281	Gauge	1
9	17-602	Nozzle Body	1
10	9032-5	Black Hose 3/4" x 5"	1
	18-040	Hose Clamp	2
11	16-800	Strainer	1
12	16-921	Nozzle	1
13	9032-13	Black Hose 3/4" x 13"	1
	18-040	Hose Clamp	2

# 17-580 20' HD SUPER BOOM PLUMBING FOR DYNAJET®

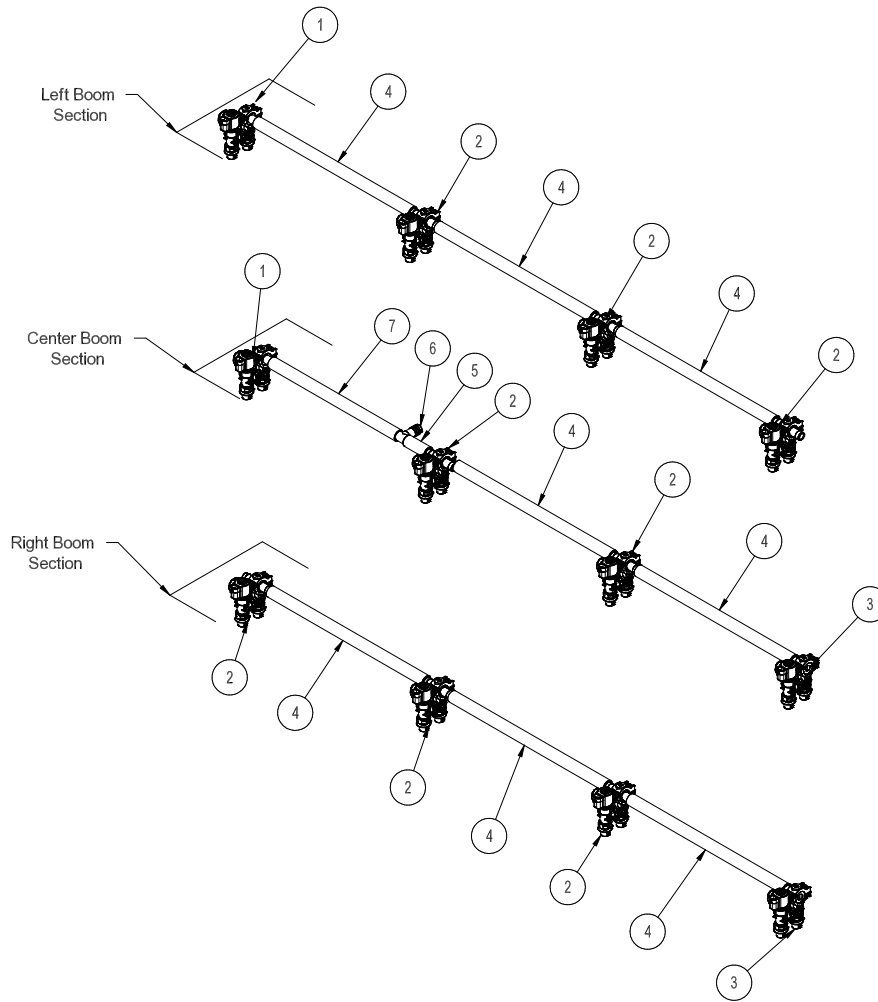

REF#	PART#	DESCRIPTION	QUANTITY
1	20-675	Single Hose Barb - Right Orientation	2
2	20-673	Single Hose Barb	8
3	20-674	Single Hose Barb - Left Orientation	2
4	9032-19	Black Hose, $\frac{3}{4}$ " x 19"	8
	18-040	Hose Clamp	16
5	9032-2.5	Black Hose, $\frac{3}{4}$ " x 2 $\frac{1}{2}$ "	1
	18-040	Hose Clamp	2
6	18-415	$\frac{3}{4}$ " Hose Barb	1
7	9032-15.5	Black Hose, $\frac{3}{4}$ " x 15 $\frac{1}{2}$ "	1
	18-040	Hose Clamp	2

Accessories

# 17-585 18' HEAVY BOOM

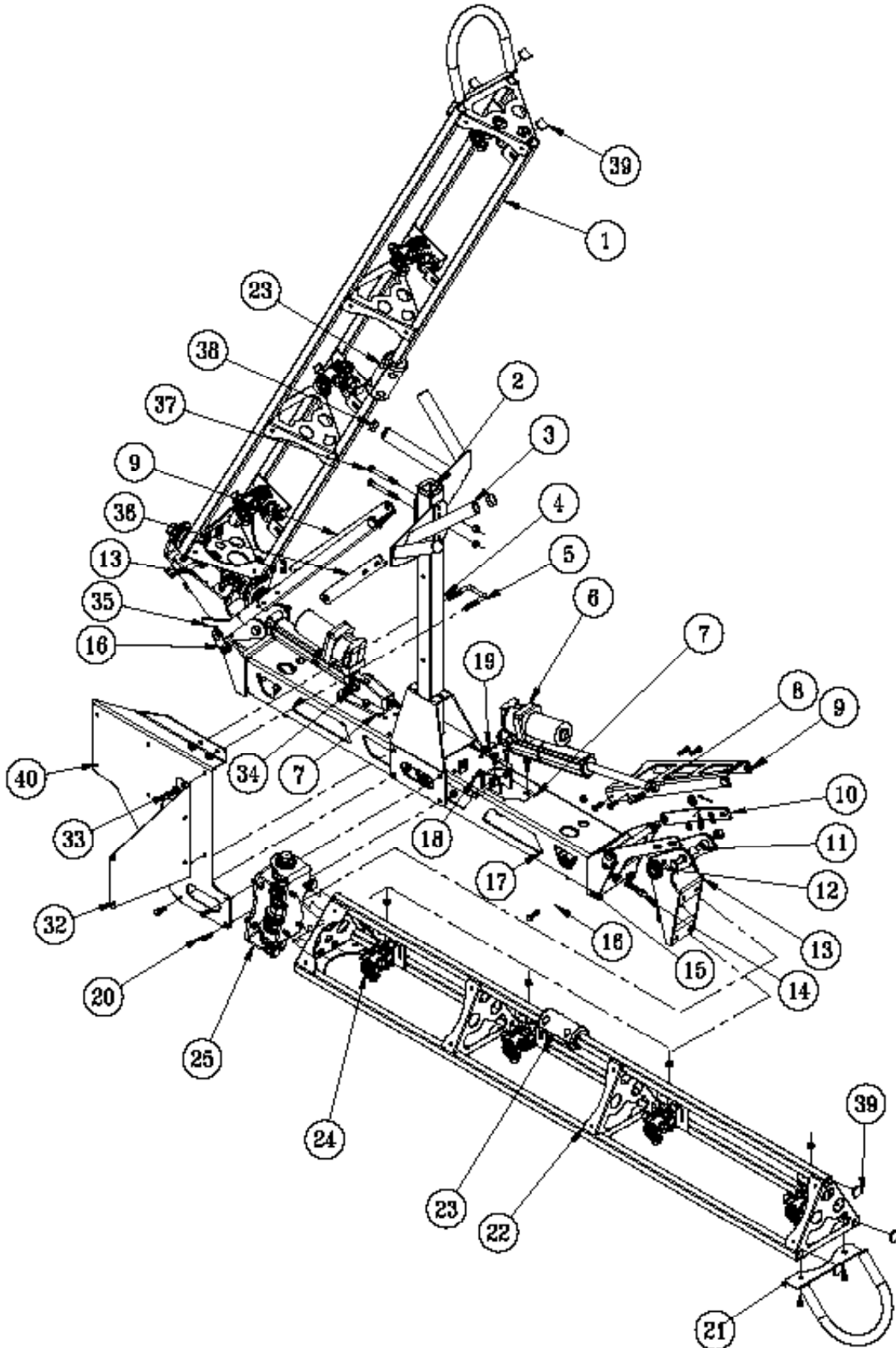

Accessories

# 17-585 18' HEAVY BOOM

REF#	PART#	DESCRIPTION	QUANTITY
1	17-531	Left Boom Arm	1
2	18-297	Cap Plug	1
3	17-617	Boom Nest	2
4	17-578	Boom Nest Post	1
5	17-537	Square U-Hex Bolt	1
6	30-214	KYB Electric/ Hydraulic Actuator (includes * items)	2
7	30-184	Ram Mount	2
	HN-38-16	Hex Nut, $\frac{3}{8}$ - 16 ( for adjustment Hex Bolts)	4
	HB-38-16-100	Hex Bolt, $\frac{3}{8}$ - 16 x 1	6
	HW-38	Flat Washer, $\frac{3}{8}$	6
	HNFL-38-16	Flange Whiz-loc Nut, $\frac{3}{8}$ -16	6
8*	18-036	$\frac{1}{2}$ " Bushing (part of 30-214)	2
9	17-587	Boom Lock	2
	HB-516-18-100	Hex Bolt, $\frac{5}{16}$ - 18 x 1	8
	HW-516	Flat Washer, $\frac{5}{16}$	4
	HNTL-516-18	Nylon Lock Nut, $\frac{5}{16}$ -18	8
	42-116	Rubber Insert	4
	8803-2.75	Trim Lace, 2.75"	2
10	17-588	Lock Hinge, RH	1
11	HB-12-13-500	Hex Bolt, $\frac{1}{2}$ - 13 x 5	2
	HNTL-12-13	Nylon Lock Nut, $\frac{1}{2}$ - 13	2
12	17-597	Torsion Spring, RH	1
13	30-185	Arm Pivot Hinge	2
	HG-14-28-180	Grease Fitting, $\frac{1}{4}$ - 28 x 180°	2
	76-128	Bushing (part of 30-185)	4
14	HB-38-16-175	Hex Bolt, $\frac{3}{8}$ - 16 x $1\frac{3}{4}$	2
	HNFL-38-16	Flange Whiz-loc Nut, $\frac{3}{8}$ - 16	4
15	17-589	Limit Hinge, RH	1
16	17-596	Hinge Pin w/ Spacer	2
	HP-18-100	Cotter Pin $\frac{1}{8}$ x 1	2
	HB-516-18-100	Hex Bolt, $\frac{5}{16}$ - 18 x 1	2
	HNFL-516-18	Flange Whiz-loc Nut, $\frac{5}{16}$ -18	2
17	17-528	Boom Center	1
19*	18-234	1" Bushing (part of 30-214)	2
20	HB-516-18-100	Hex Bolt, $\frac{5}{16}$ - 18 x 1	8
	HW-516	Flat Washer, $\frac{5}{16}$	8
	HNFL-516-18	Flange Whiz-loc Nut, $\frac{5}{16}$ - 18	8
21	17-541	Boom End Guard	2
	HBFL-516-18-075	Hex Bolt, $\frac{5}{16}$ - 18 x $\frac{3}{4}$	4
	HNFL-516-18	Flange Whiz-loc Nut, $\frac{5}{16}$ - 18	4
22	17-532	Right Boom Arm	1
23	17-573	Guide Block Set	2
	HB-14-20-125	Hex Bolt, $\frac{1}{4}$ - 20 x $1\frac{1}{4}$	8
	HNTL-14-20	Nylon Lock Nut, $\frac{1}{4}$ - 20	8
24	33-506	Body	11
	HB-516-18-075	Hex Bolt, $\frac{5}{16}$ -18 x $\frac{3}{4}$	11
	HNTL-516-18	Lock Nut, $\frac{5}{16}$ -18	11
25	17-632	Boom Hinge Complete	2
	HB-38-16-100	Hex Bolt, $\frac{3}{8}$ - 16 x 1	16
	HNFL-38-16	Flange Whiz-loc Nut, $\frac{3}{8}$ - 16	16

(Continue on next page)

# 17-585 18' HEAVY BOOM

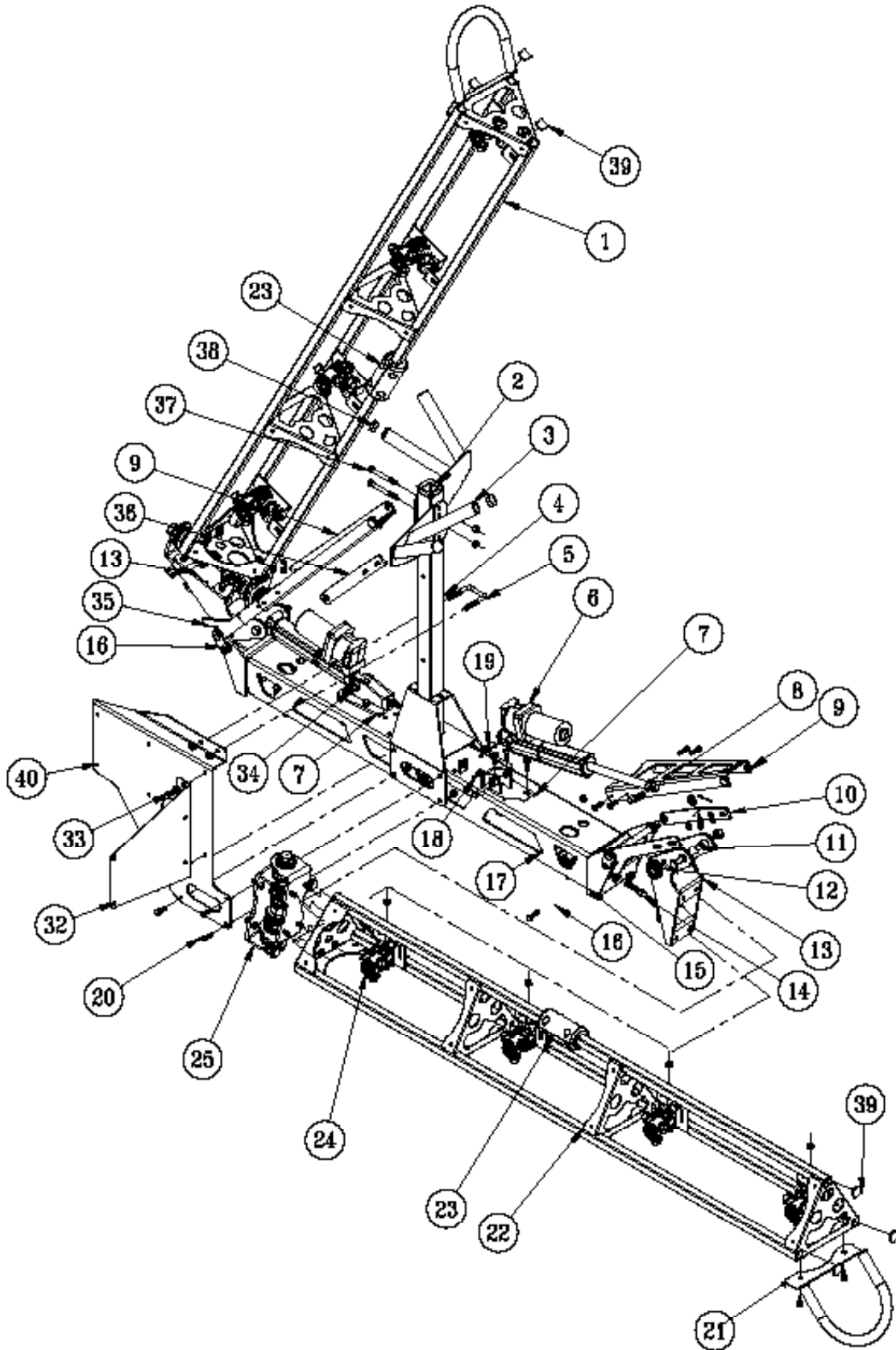

Accessories

## 17-585 18' HEAVY BOOM

REF#	PART#	DESCRIPTION	QUANTITY
32	17-636	Fresh Water Tank Mount	1
33	HB-38-16-100	Hex Bolt, $\frac{3}{8}$ - 16 x 1	2
	HNFL-38-16	Flange Whiz-loc Nut, $\frac{3}{8}$ - 16	2
	HW-38	Flat Washer, $\frac{3}{8}$	2
34	HB-12-13-300	Hex Bolt, $\frac{1}{2}$ - 13 x 3	2
	HNTL-12-13	Nylon Lock Nut, $\frac{1}{2}$ - 13	2
35	17-593	Limit Hinge, LH	1
	17-598	Torsion Spring, LH	1
36	17-592	Lock Hinge, LH	1
37	HB-38-16-300	Hex Bolt, $\frac{3}{8}$ - 16 x 3	2
	HNTL-38-16	Nylon Lock Nut, $\frac{3}{8}$ - 16	2
38	17-619	Tube Cap	4
39	30-258	Ribbed 1" Plug	10
40	17-635	Clean Load Mount	1
	8803-13	Black Trim x 13"	1

## BOOM MOUNT TO TRUCK

REF#	PART#	DESCRIPTION	QUANTITY
A		Center Boom Mount	1
B	17-614	Boom Spacer	2
C	HB-516-18-100	Hex Bolt, $\frac{5}{16}$ -18 x 1	12
	HNTL-516-18	Nylon Lock Nut, $\frac{5}{16}$ -18	12
D	20-555	U-Hex Bolt	4
	HNFL-12-13	Flange Whiz-loc Nut, $\frac{1}{2}$ - 13	8

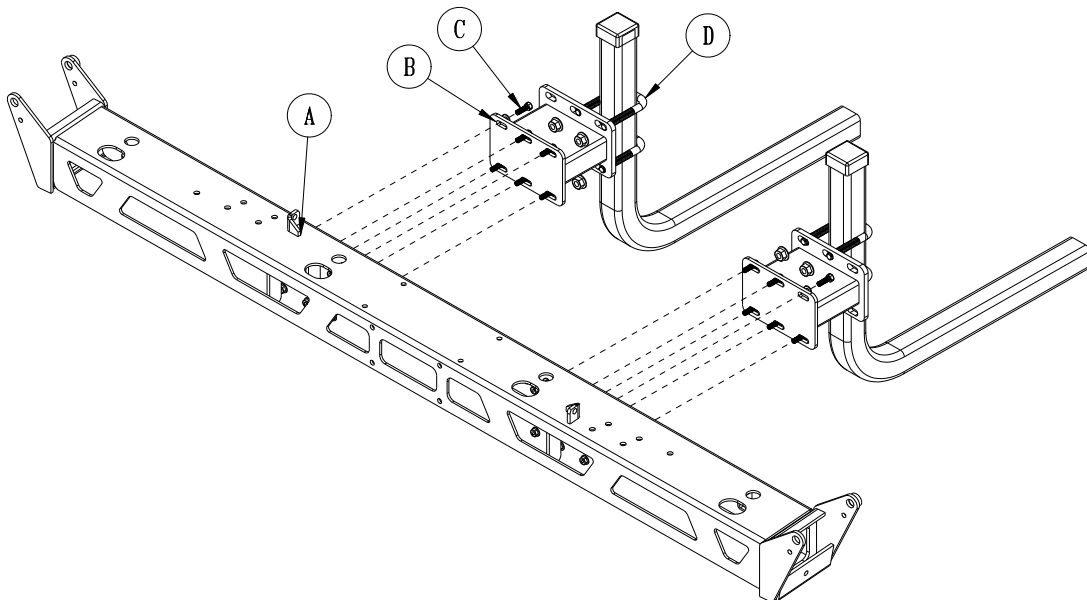

# 17-585 18' HD SUPER BOOM PLUMBING

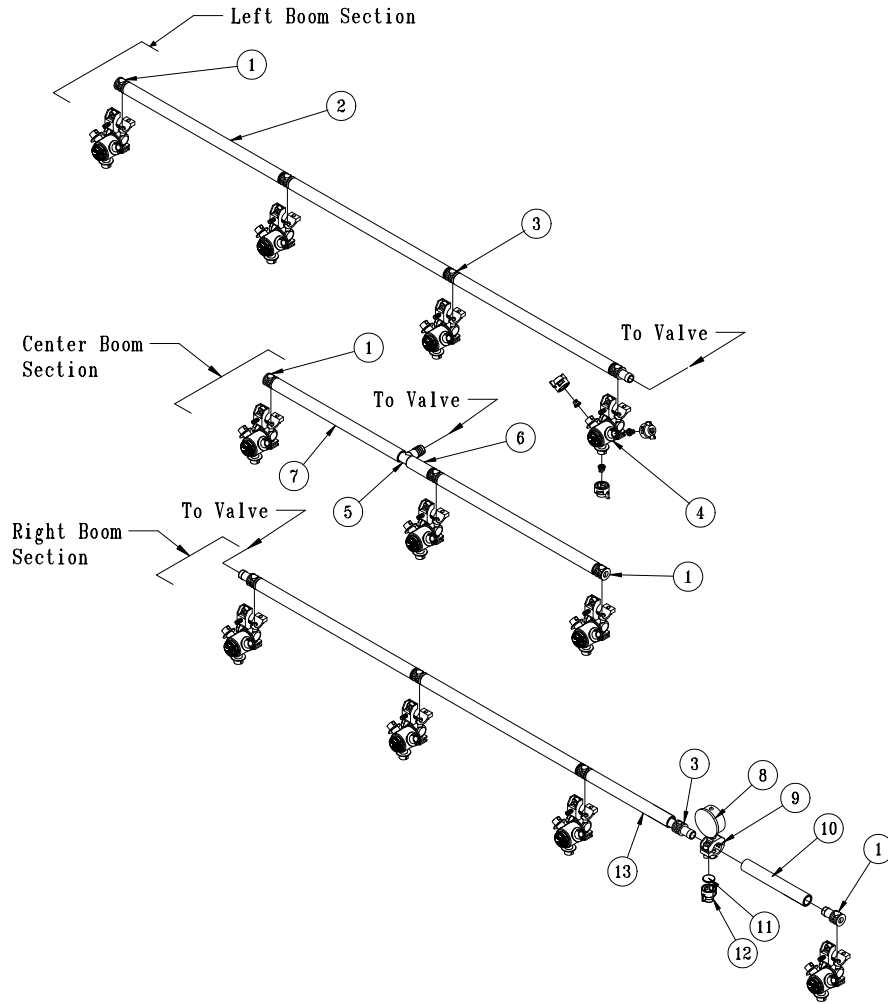

REF#	PART#	DESCRIPTION	QUANTITY
1	18-417	Single Barb	4
2	9032-19	Black Hose, 3/4" x 19"	6
	18-040	Hose Clamp	12
3	18-416	Double Barb	8
4	33-506	Nozzle body (see nozzle drawing)	11
5	18-415	3/4" Hose Barb	1
6	9032-2.5	Black Hose, 3/4" x 2 1/2"	1
	18-040	Hose Clamp	2
7	9032-15.5	Black Hose, 3/4" x 15 1/2"	1
	18-040	Hose Clamp	2
8	16-281	Gauge	1
9	17-602	Nozzle Body	1
10	9032-5	Black Hose, 3/4" x 5"	1
	18-040	Hose Clamp	2
11	16-800	Strainer	1
12	16-921	Nozzle	1
13	9032-13	Black Hose, 3/4" x 13"	1
	18-040	Hose Clamp	2

# 17-585 18' HD SUPER BOOM PLUMBING FOR DYNAJET®

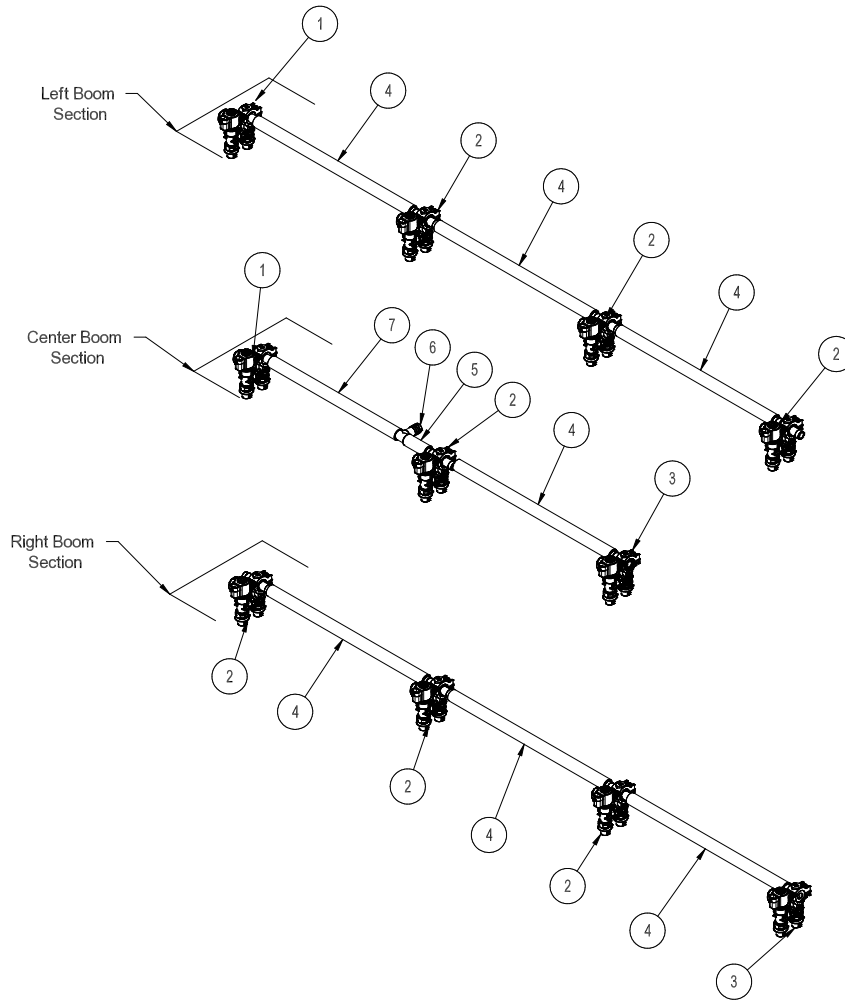

REF#	PART#	DESCRIPTION	QUANTITY
1	20-675	Single Hose Barb - Right Orientation	2
2	20-673	Single Hose Barb	8
3	20-674	Single Hose Barb - Left Orientation	2
4	9032-19	Black Hose, 3/4" x 19"	7
	18-040	Hose Clamp	14
5	9032-2.5	Black Hose, 3/4" x 2 1/2"	1
	18-040	Hose Clamp	2
6	18-415	3/4" Hose Barb	1
7	9032-15.5	Black Hose, 3/4" x 15 1/2"	1
	18-040	Hose Clamp	2

Accessories

# QJS NOZZLE DRAWING

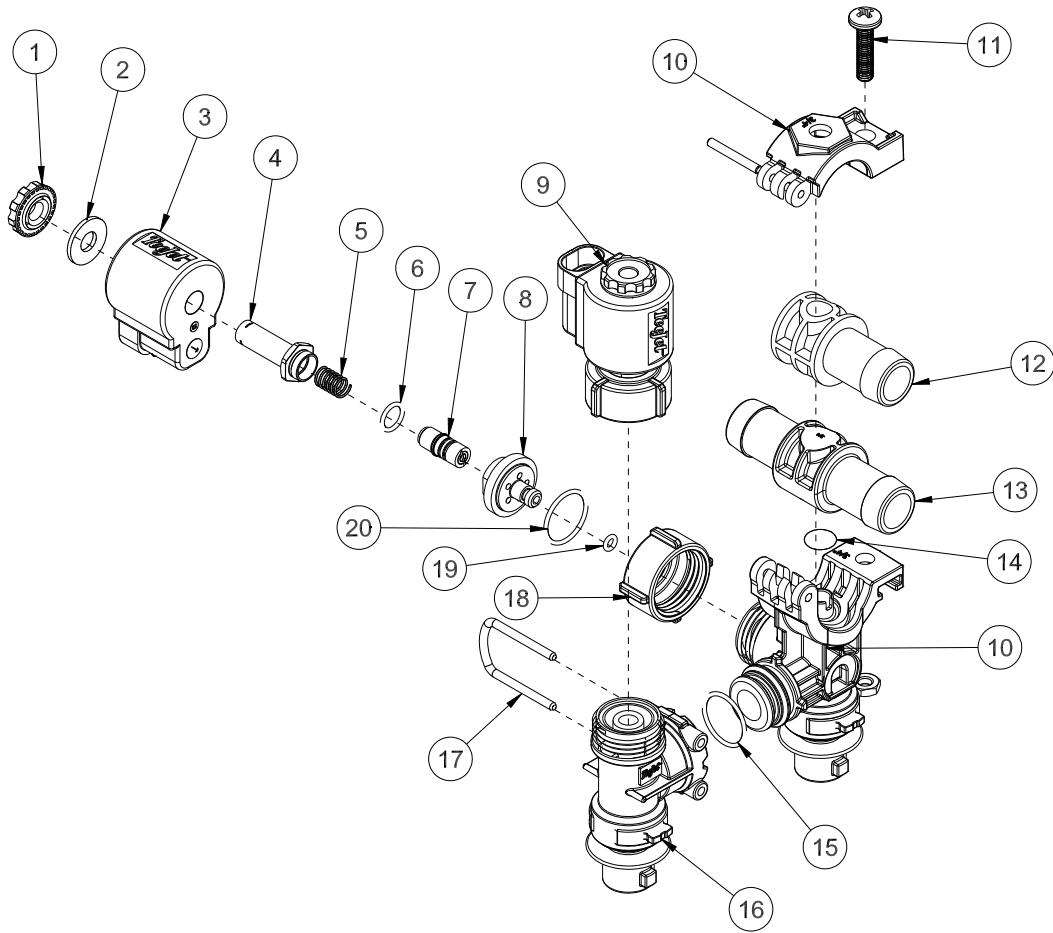

REF#	PART#	DESCRIPTION	QUANTITY
1		Nylon Black Nut	1
2		303 Stainless Steel Washer	1
3	20-673-09	12V Coil Assembly	1
4		Tube Sub Assembly	1
5*		302 Stainless Steel Spring	1
6*		Viton Oring	1
7*		Plunger	1
8		303 Stainless Steel Cap	1
9	20-673-02	E-Chemsaver Solenoid	1
10	20-673-04	3/4" Mount Assembly	1
11		Pan Head Screw	1
12	18-417	Single Barb (part of 20-674-P and 20-675-P)	1
13	18-416	Double Barb (part of 20-673-P)	1
14		Oring	1
15		Oring	1
16	20-673-05	End Body Sub-assembly	1
17		Retaining Clip	1
18		Locking Ring	1
19*	20-673-07	Viton Oring	1
20*	20-673-06	Viton Gasket	1
*	20-673-01	Spare Parts Kit	

# QJS BOTTOM MOUNT NOZZLE ASSEMBLY

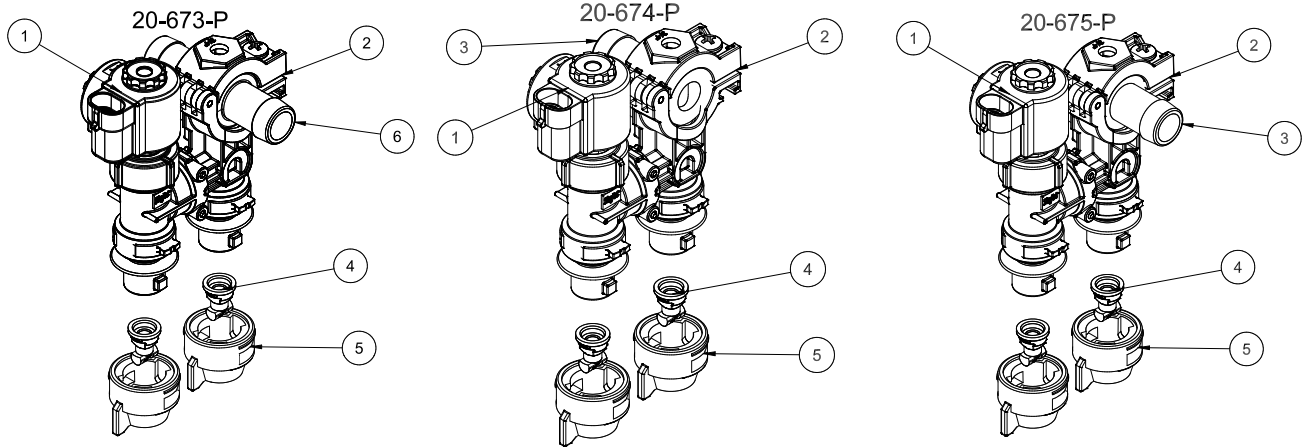

REF#	PART#	DESCRIPTION	QUANTITY
1*	20-673-02	E-Chemsaver®	1
2*	20-673-04	3/4" Bottom Mount Nozzle Body	1
3†	18-417	Single Barb	1
4	20-676	Turbo TeeJet Tip	2
5	20-677	QT White Cap and Washer	2
6‡	18-416	Double Hose Barb	1

Quantity is per nozzle body. For 18' booms multiply quantity by 11.  
 Quantity is per nozzle body. For 20' booms multiply quantity by 12.

20-673	Double Hose Barb Nozzle (includes * and ‡ item)	8 or 9
20-674	Single Hose Barb Left Orientation (includes * and † item)	2
20-675	Single Hose Barb - Right Orientation (includes * and † item)	2

Nozzles are located 20" (51 cm) apart on the right, left, and center tubes. Nozzles are 20" high off ground.

# NOZZLE ASSEMBLY

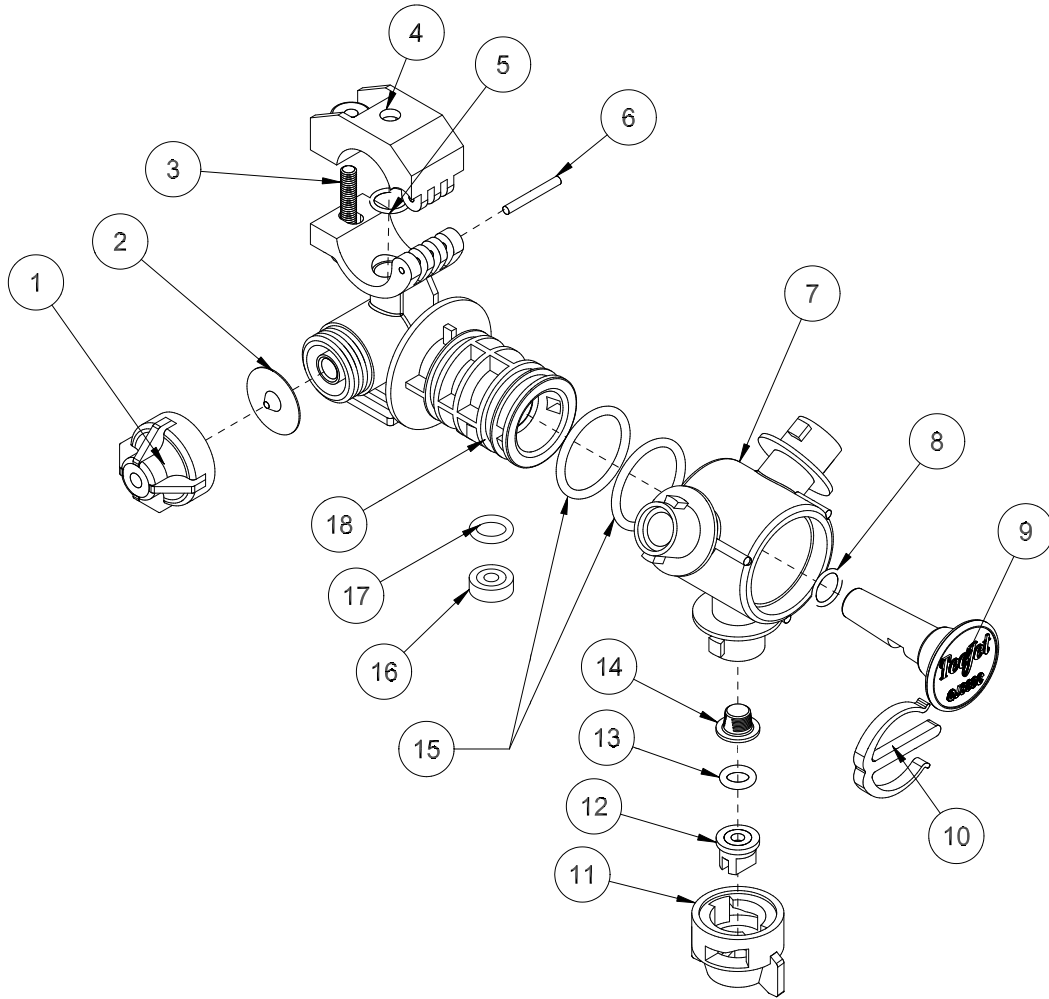

<b>REF#</b>	<b>PART#</b>	<b>DESCRIPTION</b>	<b>QUANTITY</b>
1*	16-988	Cap Assembly	1
2*	16-920-06	Diaphragm, EPDM	1
3*		Stainless Steel Screw	1
4*		Upper Clamp	1
5*	16-920-03	O-ring	1
6*		Pivot Pin, Stainless Steel	1
7		Turret, 3-Outlet, Nylon	1
8		O-ring, EPDM	1
9*		Plug	1
10*		E-clip	1
11	33-538	Cap - White	1
12	33-554	Nozzle Tip - White (XR11008-VS)	1
13	16-800	Viton Gasket	1
14	16-802	Strainer	1
15*		O-ring, Teflon	2
16*	33-506	Body Assembly (includes all * items)	1

Quantity is per nozzle body. For 20' booms multiply quantity by 12.

Quantity is per nozzle body. For 18' booms multiply quantity by 11.

Nozzles are located 20" (51 cm) apart on the right, left, and center tubes.

Nozzles are 20" high off ground.

# 30-010 ELECTRIC HOSE REEL DRAWING

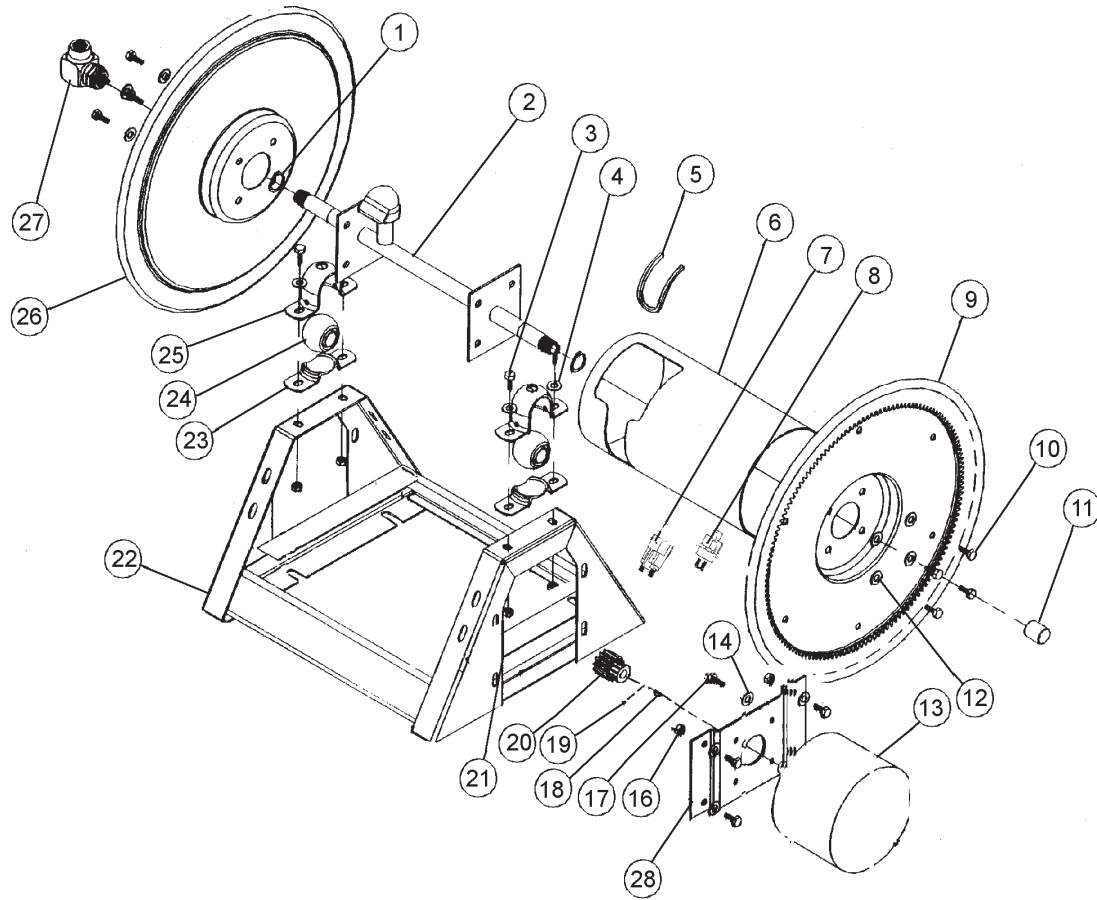

Accessories

## 30-010 ELECTRIC HOSE REEL PARTS LIST

REF#	PART#	DESCRIPTION	QUANTITY
1	16-906-25	Retaining Ring	2
2	16-906-22	Axle Assembly	1
3	HB-38-16-100	Hex Bolt, $\frac{3}{8}$ - 16 x 1	4
4	HW-38	Flat Washer, $\frac{3}{8}$	4
5	16-906-27	Trim, Drum Edge	1
6	16-906-21	Drum Center	1
7	13-750	Solenoid	1
	HB-14-20-075	Hex Bolt, $\frac{1}{4}$ - 20 x $\frac{3}{4}$	2
	HWL-14	Lock Washer, $\frac{1}{4}$	2
	HN-14-20	Hex Nut, $\frac{1}{4}$ - 20	2
8	33-251	Switch	1
9	16-906-19	Disc and Gear Assembly	1
10	HB-516-18-075	Hex Bolt, $\frac{5}{16}$ - 18 x $\frac{3}{4}$	8
11	16-906-26	Pipe Cap, $\frac{3}{4}$	1
12	HWL-516	Lock Washer, $\frac{5}{16}$	8
13		Motor 12VDC	1
14	HW-516	Flat Washer, $\frac{5}{16}$	4
16	HNTL-516-18	Nylon Lock Nut, $\frac{5}{16}$ - 18	4
17	HB-516-18-100	Hex Bolt, $\frac{5}{16}$ -18 x 1	4
18	16-906-17	Key	1
19		Set Screw	2
20	16-906-29	Pinion	1
21	HNTL-38-16	Nylon Lock Nut, $\frac{3}{8}$ - 16	4
22	16-906-18	Frame Assembly	1
23	16-906-08	Mounting Pillow Block (Bottom)	2
24	16-906-24	Bearing	2
25	16-906-07	Mounting Pillow Block (Top)	2
26	16-906-20	Disc, 17 $\frac{1}{2}$ "	1
27	16-906-23	Swivel Assembly $\frac{3}{4}$	1
	16-906-30	Seal Kit (For 16-906-23)	1
28	16-906-28	Bracket 12VDC	1
	16-982	Electric Hose Reel (only)	1



# ELECTRIC HOSE REEL WIRING DIAGRAM

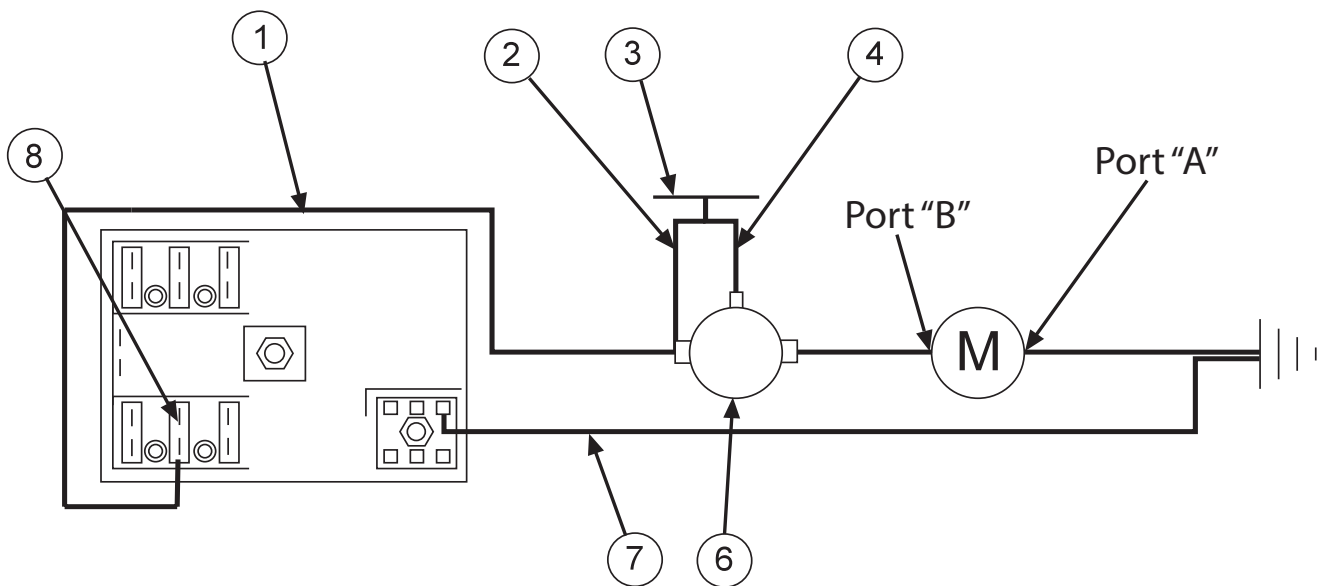

REF#	PART#	DESCRIPTION	QUANTITY
1	8843-132	Flexguard $\frac{3}{8}$ ID	1
	8919-144	10GA Red Wire 144"	1
	8854	Fork Terminal	1
2	16-979	Wire, Switch to Solenoid Hot Terminal	1
3	33-251	Push Button Switch	1
4	16-978	Wire, Switch to Solenoid Start Terminal	1
6	13-750	Solenoid	1

### SOLENOID TERMINALS

	HN -516-24	$\frac{5}{16}$ - 24 Hex Nut	2
	HN -10-32	10 - 32 Hex Nut	1
7	8931-144	10GA White Wire 144"	1
	8854	Fork Terminal	1
8	33-273	Auto Blade Type Fuse 30Amp	1

## CONNECTION INSTRUCTIONS

Route wire harness along side of tank and over to fuse block taking care to stay clear of moving parts or hot engine components. Cut off excess wire and strip back  $\frac{3}{8}$ ". Place one 8963 heat shrink ( $\frac{1}{4} \times 1\frac{1}{4}$ ") on each wire before crimping 8901 slide on connectors to the red and white wires. Connect the two wires to the fuse block first the red to the (+) positive and the white to the (-) negative. Put the 33-273 auto blade type fuse (30 amp) into fuse block.

### ⚠ WARNING

**Make certain you are connecting positive (+) to positive; negative (-) to negative while attaching power leads. If you do not observe polarity, damage will result to electrical components.**

*Use Dielectric Grease On All Electrical Connections*

# 30-009 MANUAL HOSE REEL DRAWING

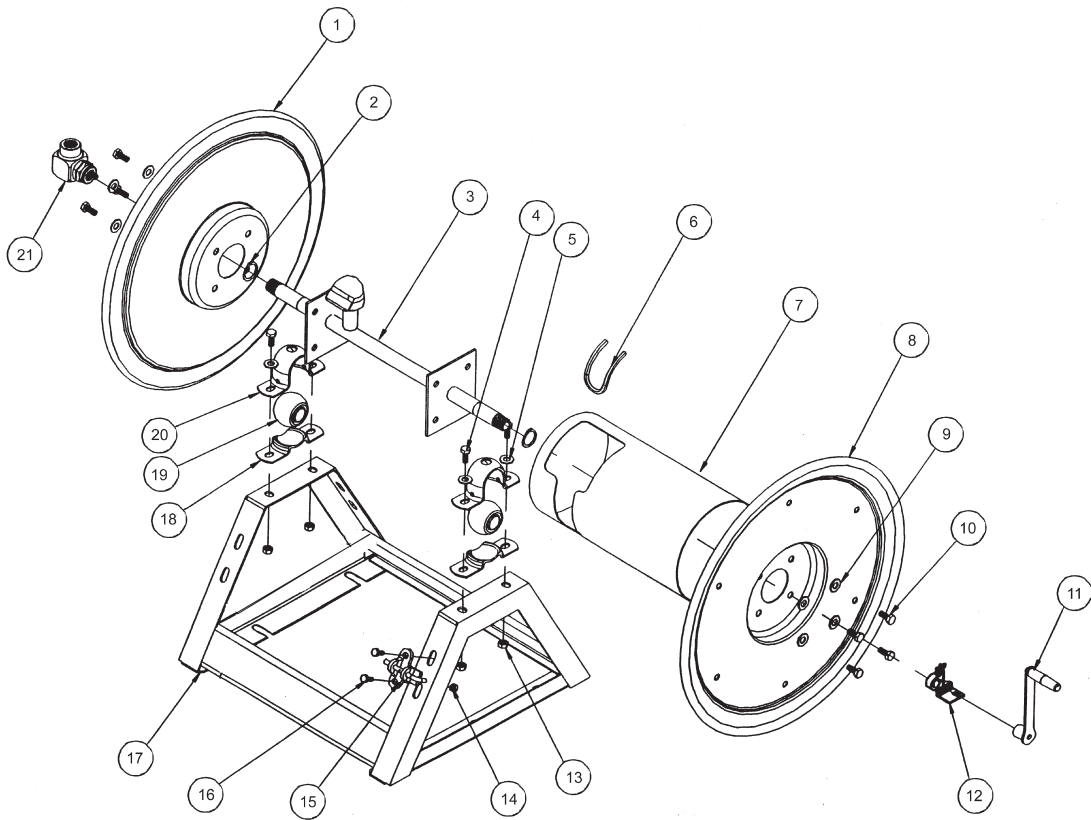

REF#	PART#	DESCRIPTION	QUANTITY
1	16-129-11	Disc, 17 $\frac{1}{2}$ "	1
2	16-906-25	Retaining Ring	2
3	16-906-22	Axle Assembly $\frac{3}{4}$ "	1
4	HB-38-16-100	Hex Bolt, $\frac{3}{8}$ - 16 x 1	4
5	HW-38	Flat Washer, $\frac{3}{8}$	4
6	16-906-27	Trim, Drum Edge	1
7	16-906-21	Drum Center	1
8	16-906-20	Disc 17 $\frac{1}{2}$ ", Crank Side	1
9	HWL-516	Lock Washer, $\frac{5}{16}$	8
10	HB-516-18-075	Hex Bolt, $\frac{5}{16}$ - 18 x $\frac{3}{4}$	8
11	16-129-09	Crank Assembly, $\frac{3}{4}$ "	1
12	16-129-10	Brake Assembly, $\frac{3}{4}$ "	1
13	HNTL-38-16	Nylon Lock Nut, $\frac{3}{8}$ - 16	4
14	HNTL-516-18	Nylon Lock Nut, $\frac{5}{16}$ - 18	2
15	16-129-08	Lock Pin Assembly	1
16	HB-516-18-075	Hex Bolt, $\frac{5}{16}$ - 18 x $\frac{3}{4}$	2
	HW-516	Flat Washer, $\frac{5}{16}$	2
17	16-129-07	Frame Assembly	1
18	16-906-08	Mounting Pillow Block (Bottom)	2
19	16-906-24	Bearing	2
20	16-906-07	Mounting Pillow Block (Top)	2
21	16-906-23	Swivel Assembly, $\frac{3}{4}$ "	1
	16-906-30	Seal Kit ( For 16-906-23 )	1

# HOSE REEL MOUNT DRAWING

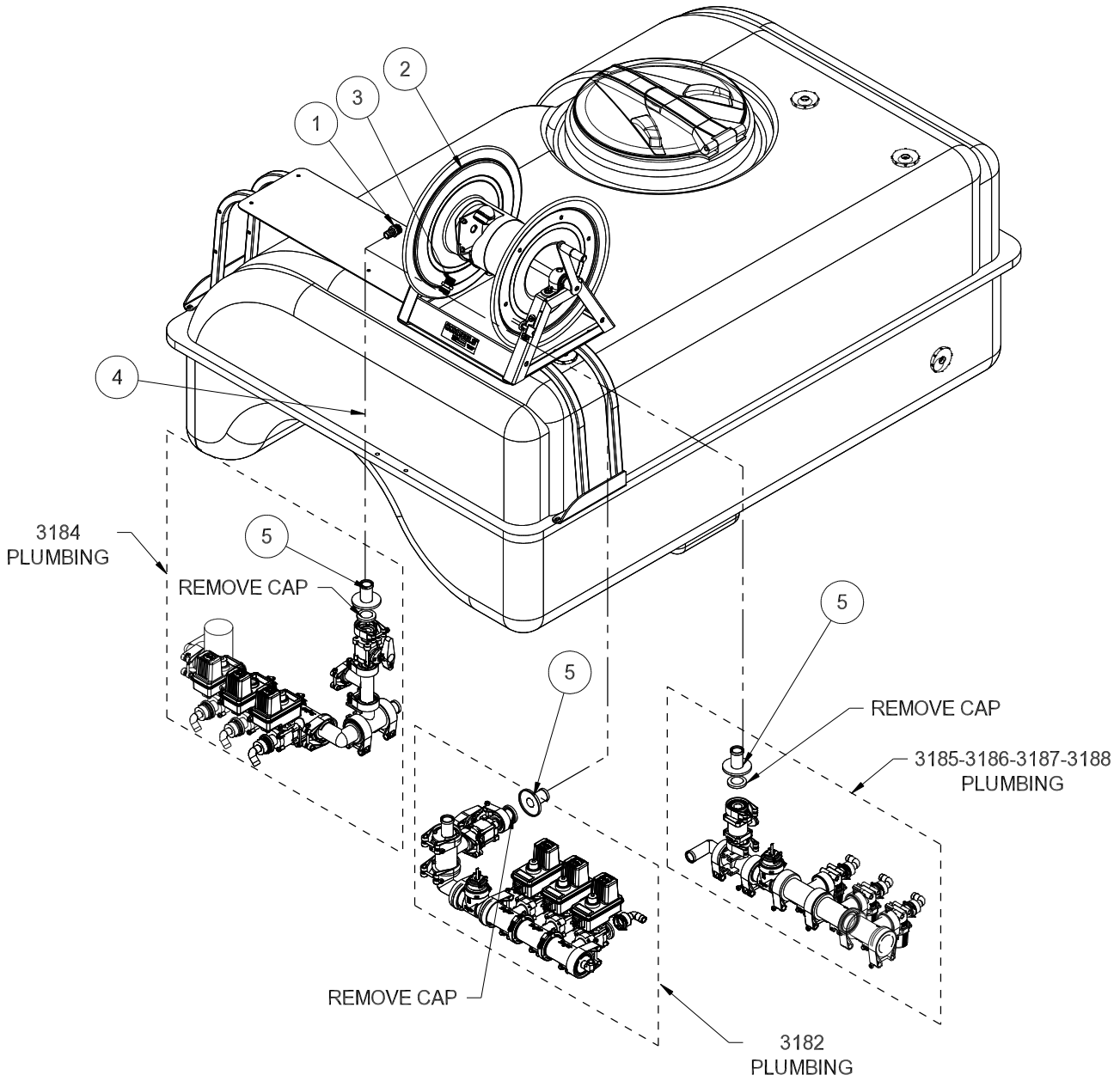

Accessories

## HOSE REEL MOUNT PARTS LIST

REF#	PART#	DESCRIPTION	QUANTITY
1	18-249	Barb Fitting	1
2	16-129	Manual Crank Hose Reel	1
	16-982	Electric Hose Reel	1
	HB-516-18-150	Hex Bolt, $\frac{5}{16}$ - 18 x $1\frac{1}{2}$	4
	HW-516	Flat Washer, $\frac{5}{16}$	4
	HNTL-516-18	Nylon Lock Nut, $\frac{5}{16}$ - 18	4
3	16-295	Hose Fitting, $\frac{3}{4}$	1
4	9032-110	Black Hose, $\frac{3}{4}$ " x 110"	1
	18-040	Hose Clamp	2
5	15-749	Hose Barb, $\frac{3}{4}$	1

1. Wear protective clothing when draining the tank and taking apart the lines.
2. Drain tank and spray system in a safe and approved method insuring that no chemical or water remain in tank as you will be taking apart lines.
3. Remove key from ignition, set park brake and block wheels.
4. Put hose reel on hose reel bracket with fitting to the rear of machine. Use four Hex Bolts  $\frac{5}{16}$  - 18 x  $1\frac{1}{2}$  and four  $\frac{5}{16}$  - 18 lock nuts to hold in place. Tighten Hex Bolts.
5. Put 18-249 barb fitting into hose reel side.
6. Place the 16-295 Hose Fitting into the Hose reel center.
7. Remove the blank cover from the ball valve by the manifold valve and place the 15-749 Hose Barb. Tighten clamp.
8. Route hose from the hose barb on the ball valve to the barb fitting on the side of the hose reel. Hold in place with the two 18-040 clamps.
9. Be sure all clamps and hardware are tight before using.

## HOSE REEL ADJUSTMENTS

### OPERATIONAL CHECK:

1. Pull hose off drum at least one full revolution. A clicking noise should be heard from locking mechanism.
2. Let the hose retract.
3. Pull the hose off until the first click is heard. Drum should lock when the hose tension is removed.
4. Continue pulling the hose, no more than one revolution, until no clicking is heard. Hose should rewind when tension is removed.

### HOSE REPLACEMENT PROCEDURE:

1. Facing swivel, turn the hose drum clockwise until all of the hose is removed from the drum and the drum is held by locking mechanism. Make sure spring is locked.
2. Remove hose clamps and disconnect hose from swivel. Remove old hose.
3. Insert new hose through roller guide, connect to swivel and reinstall hose clamps. Use spring guard over hose to protect the hose from being cut by the drum.
4. Remove check ball from old hose and install on replacement hose.
5. Carefully, keeping the tension on the hose, pull the hose to release the locking mechanism. Let the hose wind on the drum.

# 30-004 FOAM MARKER DRAWING

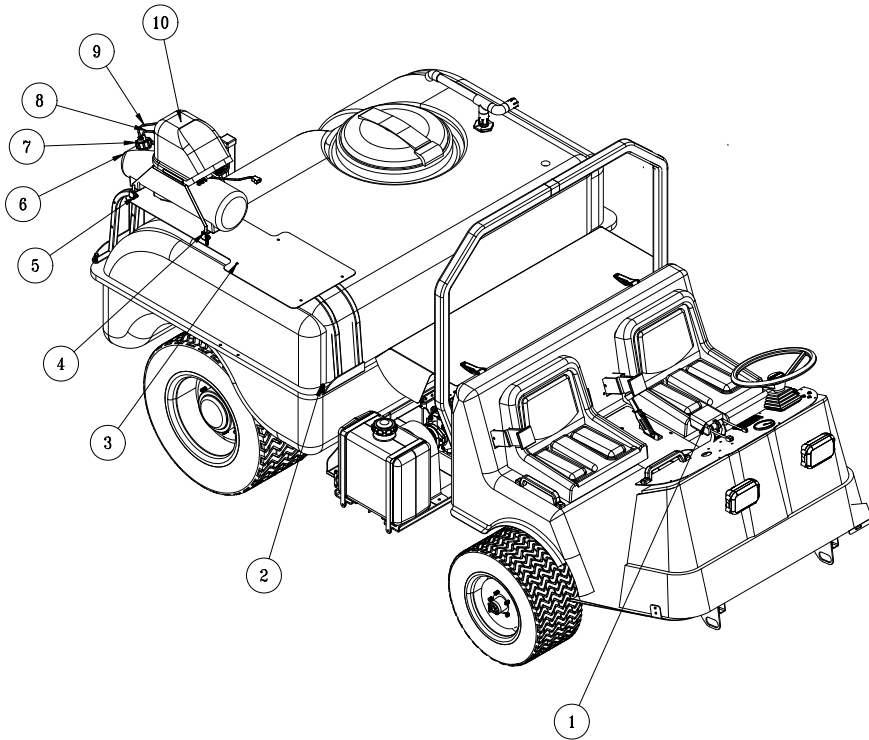

# WIRING DRAWING

Accessories

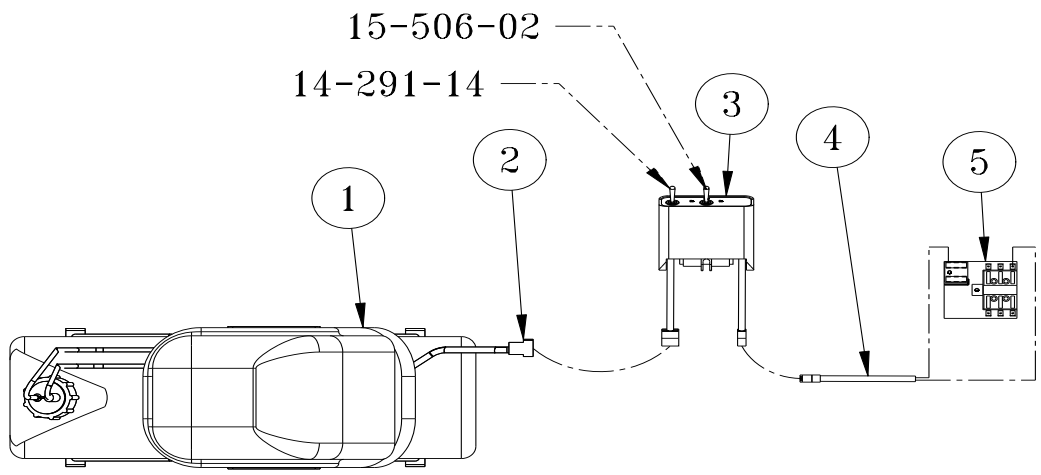

## 30-004 FOAM MARKER PARTS LIST

REF#	PART#	DESCRIPTION	QUANTITY
1*	14-291-05	Double Switch Box	1
	33-508	Fuse	1
	15-506-02	Center Switch	1
	14-291-14	Switch	1
2	HB-516-18-175	Hex Bolt, $\frac{5}{16}$ - 18 x $1\frac{3}{4}$ (part of machine)	4
	HNFL-516-18	Flange Lock Nut, $\frac{5}{16}$ - 18 (part of machine)	4
3	30-110	Mount Bracket (part of machine)	1
4*	14-291-04	Tank Bracket	2
5	HB-14-20-075	Hex Bolt, $\frac{1}{4}$ - 20 x $\frac{3}{4}$	4
	HNFL-14-20	Flange Lock Nut, $\frac{1}{4}$ - 20	4
6*	14-291-02	Foamer Tank	1
7*	14-284-02	Cap Assembly	1
8*		Blue Tube	1
9*		Clear Tube	1
10*	14-291-03	Compressor Only	1
	14-291-01	Black Cover	1
*	14-291	Foamer (includes * parts)	1

## WIRING PARTS LIST

REF#	PART#	DESCRIPTION	QUANTITY
1	14-291-03	Compressor	1
2	15-504-04	Wiring Harness	1
3	14-291-05	Switch Box	1
	33-508	Fuse	1
	15-506-02	Center Switch	1
	14-291-14	Outside Switch	1
4	15-509	Power Cable	1
5		Fuse Block (part of machine)	1
	33-293	Auto Blade Type Fuse 30 amp	1

# 30-004 FOAM MARKER DRAWING

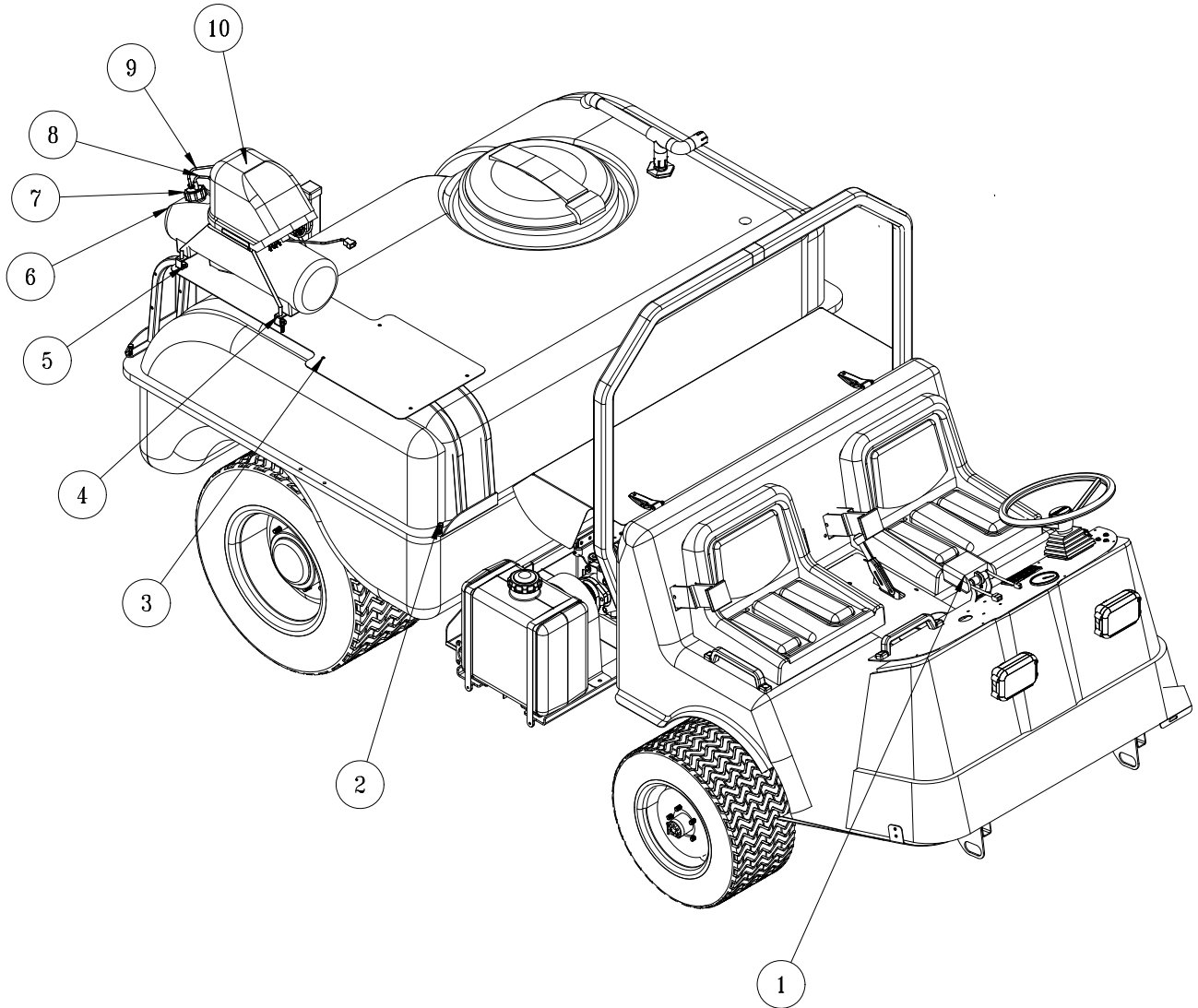

Accessories

# INSTALLATION INSTRUCTIONS

*Safety: Before working on machine stop engine, set park brake, remove key from ignition and block wheels. Disconnect negative (-) battery terminal.*

## BOX MOUNT

Mount the switch box to the lower center of the dashboard. Remove the two Phillips head Hex Bolts. Reinstall the #10 x 1 Phillips head Hex Bolts and lockwashers to hold the switch box onto the dashboard. Tighten all Hex Bolts.

## WIRING

Use dielectric grease on all electrical connections. Connect power cable (15-509) to the switch box. Turn the switch off. Route the power wire down through the grommet in the dashboard. Follow the wire harness down under the floorboard, then back along the main frame and up to the fuse block in the engine compartment behind the passenger seat. The power cable will need to be cut and shortened. Attach fork terminals to the wire ends with heat shrink, then connect to fuse block. Red to positive(+), black to negative(-). Insert 10 AMP fuse into slot which has red wire attached to it.

Route Control Harness (15-504) from switch box on dashboard same as the power wire. Only continue all the way to the rear of the machine. Then pull the cable up over the back of the spray tank so it can be connected to the compressor.

## CONNECTING THE CAP ASSEMBLY

Connect the blue tube to the tank cap connector which is also connected to the large blue tube which hangs below the cap. This is the soap outlet tube. Connect the clear tube to the other connector on the tank cap. This is the air input tube. Tighten connectors hand tight, assembly tank cap onto tank.

## HOSES

Being careful not to cut the tubing, cut the over sleeve back approximately 2" (5 cm) to expose blue and clear tubing. Remove blue wing nut from top connector of foam nozzle and slide it on the blue tube with the threads facing toward end of tube. Slide blue tube all the way over the top of the small tube on foam nozzle. Slide wing nut back to the threads and hand tighten. Follow the same steps for the clear tube and tube nut.

Route the tubing along underside of main frame using tie downs as necessary.

Install opposite ends of air-liquid tubes to compressor, again cutting back the over sleeve approximately 2" (5 cm) and inserting blue and clear tubes for the left boom section into the tubing connectors on the right side of compressor as far as possible. Follow the same steps for the right boom tubing. Notice the right boom is inserted into left side of compressor. To release tubing from compressor, hold black ring around tubing, and pull tube out.

# FOAMER NOZZLE MOUNT & HOSE GUARD MOUNT DRAWING

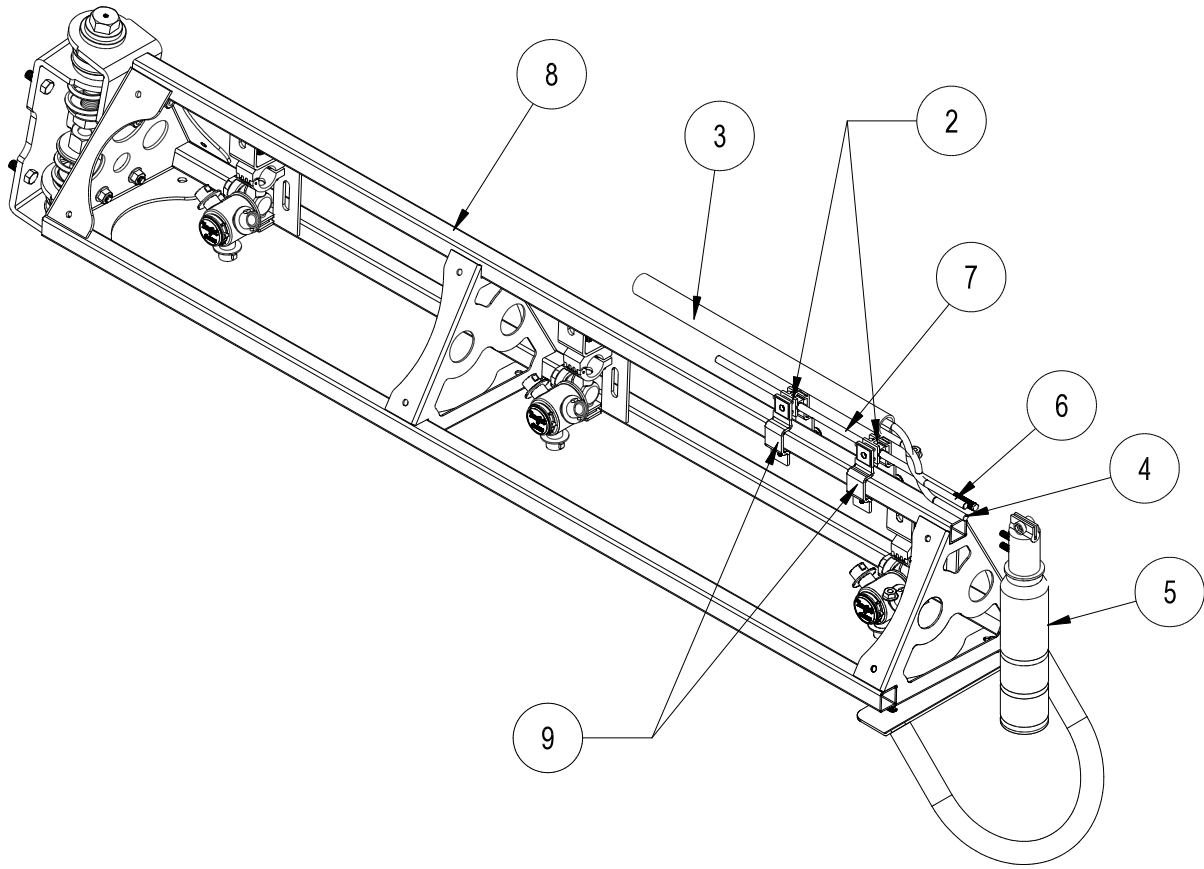

Accessories

## 30-162 FOAM MARKER PARTS LIST

REF#	PART#	DESCRIPTION	QUANTITY
1	15-537	Foamer Hose Guard 31"	4
	HSDPS-14-075	Stainless Steel Pan Head Drill Screw, 1/4 x 3/4	8
2	16-987	Foam Nozzle Mounting Kit	1 per boom
3	15-507	Foamer Tubing	1
4		Clear Tubing	
5	15-511	Foam Nozzle	2
6		Blue Tubing	
7	15-510-01	Nozzle Mounting Rod	2
8		Boom	
9	16-795	Square Clamp	4

- Slide hose clamp onto drop tube of foam nozzle and attach restrictor bell.
- Place splined end of Nozzle mounting rod (Ref 7) into top of foam nozzle (Ref 5). Tighten screw.
- Slide two foam nozzle mounts (Ref 2) onto the rod. Place square clamps (Ref 9) on foam nozzle mounts and mount the square clamps to the boom (Ref 8). Adjust foam nozzle mounts and clamps so nozzle assembly will clear end of boom. Tighten foam nozzle mounts and square clamps to prevent side to side movement. Do the same to the other side.
- Being careful not to cut the tubing (Ref 3), cut the over sleeve back approximately 2" (5 cm) to expose blue (Ref 6) and clear tubing (Ref 4).
- Remove blue wing nut from top connector of foam nozzle and slide it on the blue tube with the threads facing toward end of tube. Slide blue tube all the way over the top of the small tube on foam nozzle. Slide wing nut back to the threads and hand tighten. Follow the same steps for the clear tube and tube nut.
- Route the tubing along underside of main frame using tie downs as necessary.
- Install opposite ends of air-liquid tubes to compressor, again cutting back the over sleeve approximately 2" (5 cm) and inserting blue and clear tubes for the left boom section into the tubing connectors (Ref A) on the right side of compressor as far as possible.
- Follow the same steps for the right boom tubing. Notice the right boom is inserted into left side of compressor. To release tubing from compressor, hold black ring around tubing, and pull tube out.
- Hose's must be routed on bottom of the boom square tubing.
- Mark 6 inches in from inside edge of foamer nozzle mounting bracket on square boom tubing.
- Place hose guard (Ref 1) flush with top of square tubing with edge on previous mark. The channel covers hoses on the bottom of the square tubing.
- Install hose guard using 2 drill screws (you may want to drill a 3/16 pilot hole first).
- Place another hose guard against first and install in same manner.
- Repeat process for other boom side.
- Connect small plastic electrical plug under compressor to electrical extension cable.
- Cut cable and strip casing, allowing enough length to connect to fuse block.
- Strip and connect slide on connectors to each wire and use the heat shrink.
- Connect black negative (-) wire to the ground and connect red wire to the positive (+).
- Insert 10 amp fuse into slot which red wire was attached to.

# 14-291 FOAMER REPLACEMENT PARTS

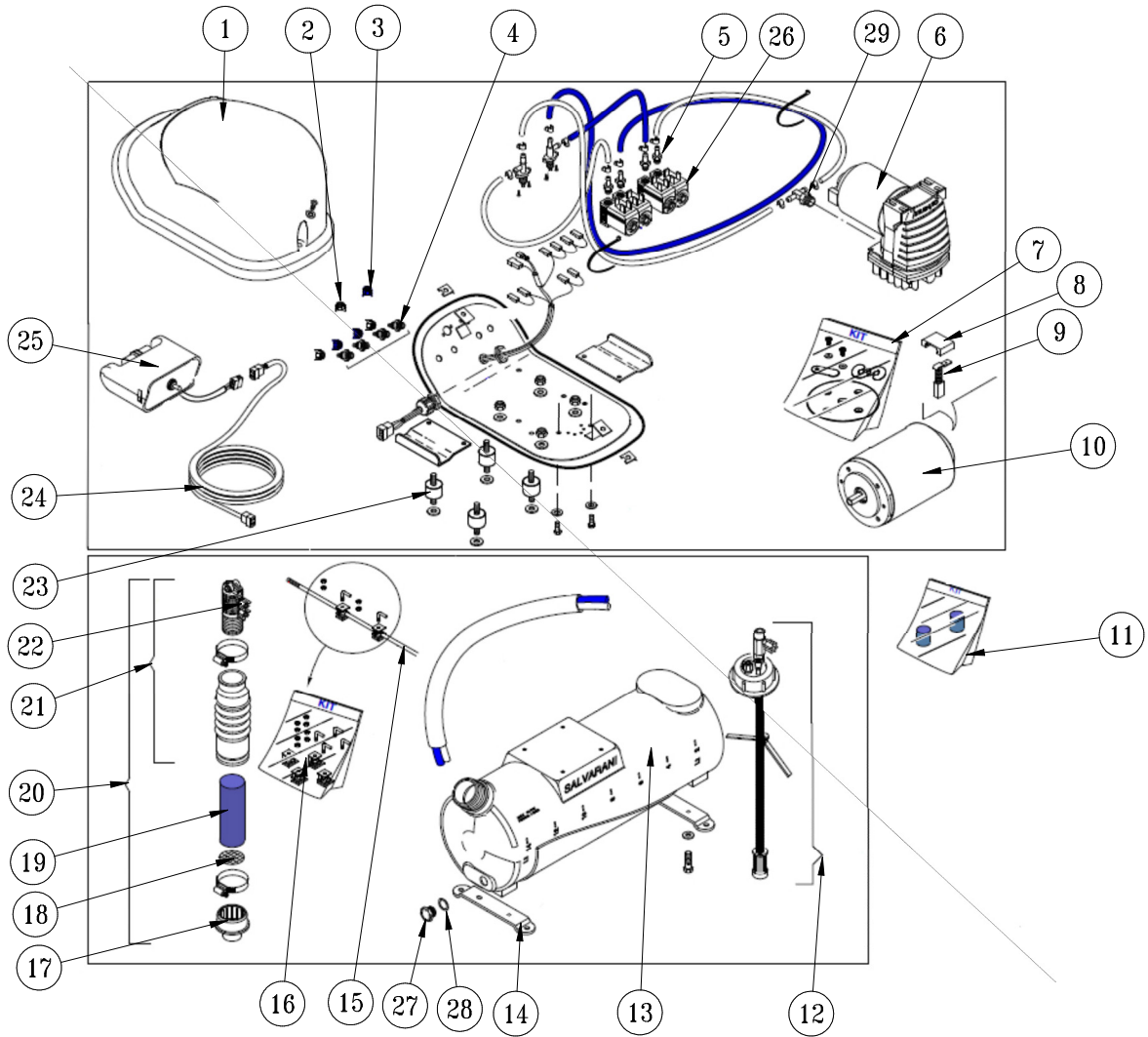

Accessories

## 14-291 FOAMER REPLACEMENT PARTS

REF#	PART#	DESCRIPTION	QUANTITY
1	14-291-01	Black Cover	1
2	14-291-08	White Fly Nut	1
3	14-291-09	Blue Fly Nut	1
4	14-284-10	Tubing Connector	1
5	14-291-17	M6 Tubing Connector	1
6	14-536	Compressor Complete	1
7	14-291-11	Diaphragm Replacement Kit	1
8	15-505-08	Brush Retainer	1
9	15-505-06	Brush	1
10	15-505-07	12V Electric Motor	1
11	15-511-02	Foam Sponge	1
12	14-284-02	Cap Assembly	1
13	14-291-02	Foamer Tank	1
14	14-291-04	Tank Brackets	2
15	15-510-01	Nozzle Mounting Rod	2
16	16-987	Foam Nozzle Mounting Kit	1
17	14-284-09	Foam Nozzle Reducer	2
18	15-511-09	Stainless Steel Screen	2
19	15-511-08	Long Foam Sponge	2
20	15-511	Foam Nozzle	2
21	15-511-07	Foam Nozzle Assembly	1
22	15-511-01	Foam Nozzle Sub Assembly	1
23	14-291-15	Shock Absorber	4
24	14-284-05	Extension Wire	1
25	14-291-05	Switch Box	1
	15-506-02	Switch	1
26	14-284-11	Solenoid Valve	4
27	14-291-19	Drain Plug	1
28	14-291-18	Drain Plug Seal	1

# 14-291 FOAM MARKER DRAWING



REF#	PART#	DESCRIPTION	QUANTITY
1	15-507	Foamer Tubing	2
2	14-291-02	Tank	1
3	14-291-01	Black Cover	1
	14-536	Compressor Complete	1
4	14-284-02	Cap Assembly	1
5	14-291-04	Tank Bracket	2
6	14-291-05	Switch Box	1
7	15-511	Foam Nozzle	2
8	15-510-01	Nozzle Mounting Rod	2
9	16-987	Foam Nozzle Mounting Kit	1
10	14-284-05	Extension Wire	1

## 14-515 WATER METER KIT (GALLONS)

## 15-618 WATER METER KIT (LITERS)

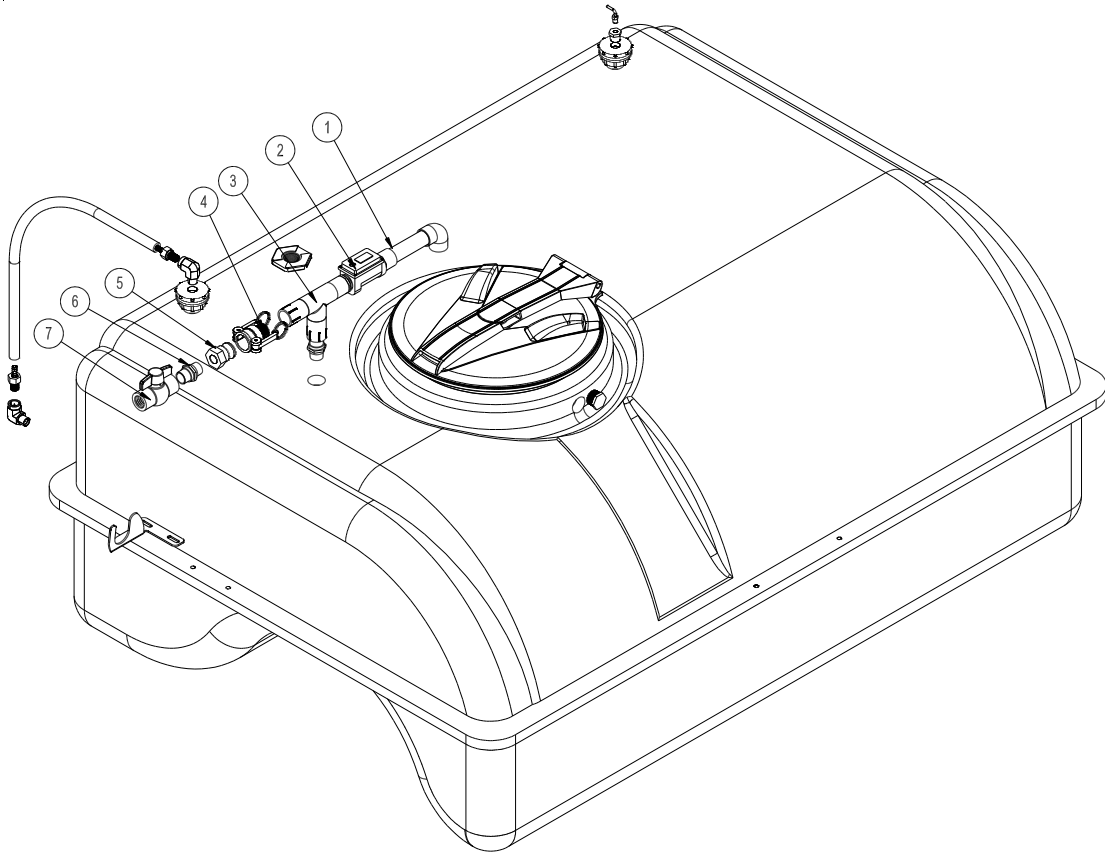

REF #	PART #	DESCRIPTION	QUANTITY
1	14-524	Filler Outlet	1
2	14-514	Water Meter (Gallons)	1
	14-527	Water Meter (Liters)	1
3	14-525	Filler Inlet	1
4	16-962	1" Quick Coupler (already on machine)	1
5	16-961	1" Adapter Quick Coupler (already on machine)	1
6	16-851	1" Nipple (already on machine)	1
7	18-448	1" Ball Valve (already on machine)	1

1. Thoroughly flush the service line upstream of the meter to remove dirt and debris.
2. The DLJ Meter is for use **only** with **COLD WATER** up to 122°F (50°C)
3. Slowly open any upstream valves to prevent damage to the meter.

### Gallons to Cubic feet Conversion :

Multiply gallons reading by 0.1337 to get cubic feet.

There are 7.48052 gallon per cubic foot.

# 20-758 FRESH WATER WASH TANK - FRONT MOUNT

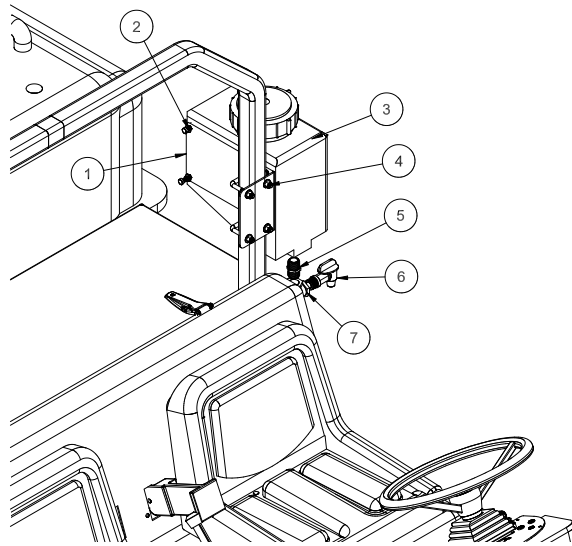

REF#	PART#	DESCRIPTION	QUANTITY
1	20-757	Mount Plate	1
2	HB-516-18-075	Hex Bolt, $\frac{5}{16}$ - 18 x $\frac{3}{4}$	4
	HWL-516	Lock Washer, $\frac{5}{16}$	4
	HW-516	Flat Washer, $\frac{5}{16}$	4
3	10-234	Wash Tank	1
4	17-537	Square U-Bolt	2
5	16-158	Close Nipple	1
6	16-151	Elbow	1
7	16-960	Spigot	1

1. Fresh Water Wash Tank mounts on the left side ROPs.
2. Mount the wash tank (Ref 3) onto the mount bracket (Ref 1) using four  $\frac{5}{16}$  x  $\frac{3}{4}$  bolts, washers and lock-washers (Ref 2). Tighten.
3. Install the nipple (Ref 5), elbow (Ref 6) and spigot (Ref 7) into the bottom of wash tank (Ref 1). Use thread tape on all threads.
4. Mount the tank assembly to the left side ROPs with u-bolts (Ref 4). Tighten.
5. Rinse tank with clear water and check for leaks around fittings.



**WARNING**

**This tank is for fresh clear water ONLY. Do not put chemicals in this tank.**

## 30-006 FRESH WATER TANK - REAR MOUNT

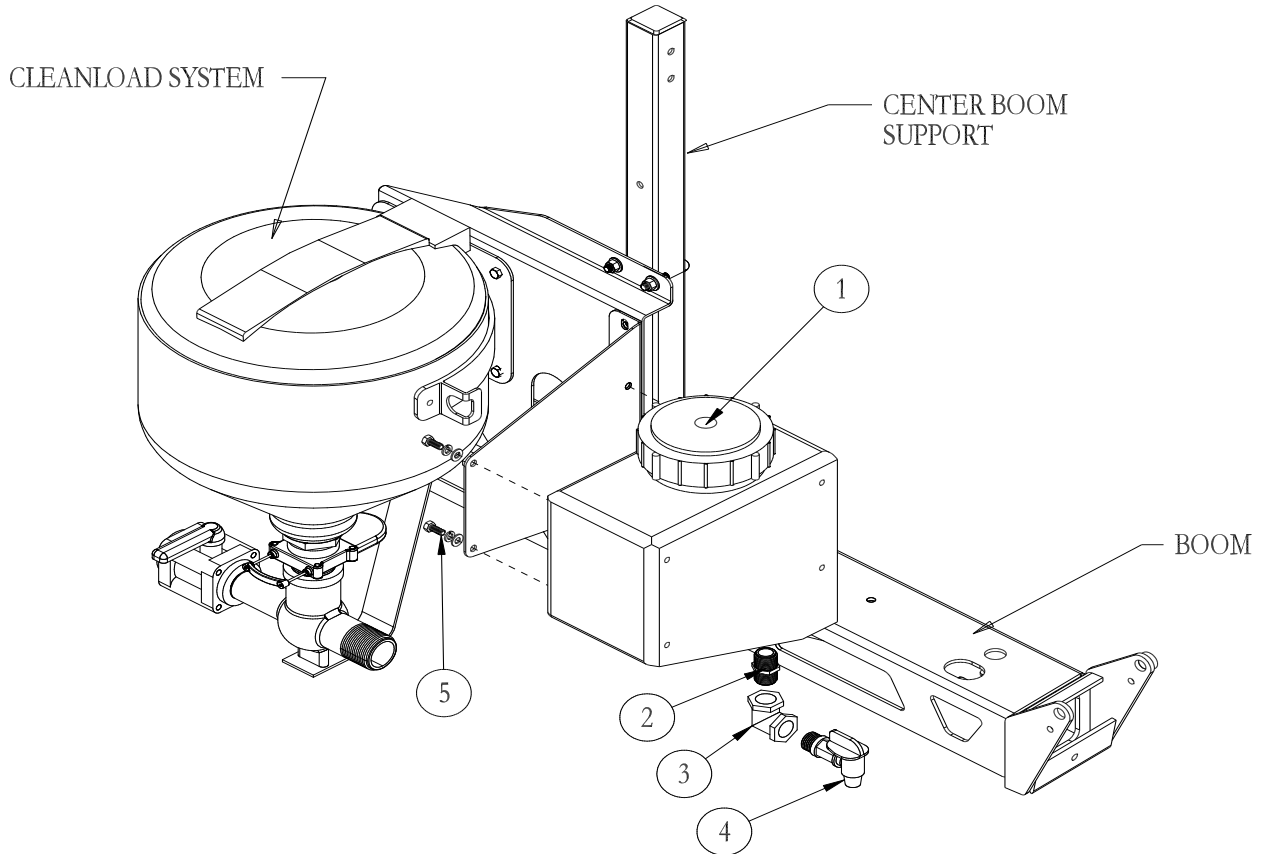

REF#	PART#	DESCRIPTION	QUANTITY
1	10-234	Wash Tank	1
2	16-158	Close Nipple	1
3	16-151	Elbow	1
4	16-960	Spigot	1
5	HB-516-18-075	Hex Bolt, $\frac{5}{16}$ - 18 x $\frac{3}{4}$	4
	HWL-516	Lock Washer, $\frac{5}{16}$	4
	HW-516	Flat Washer, $\frac{5}{16}$	4

1. Fresh Water Wash Tank mounts on the rear of all the machines.
2. The Bracket is already attached to the Super Boom center boom post.
3. Install the nipple (Ref 2), elbow (Ref 3) and spigot (Ref 4) into the bottom of wash tank (Ref 1). Use thread tape on all threads.
4. Mount the tank onto the mount bracket using four  $\frac{5}{16}$  x  $\frac{3}{4}$  Hex Bolts, washers and lockwashers. Tighten.
5. Rinse tank with clear water and check for leaks around fittings.



**WARNING**

**This tank is for fresh clear water ONLY. Do not put chemicals in this tank.**

# 30-007 CHEMICAL CLEAN-LOAD DRAWING

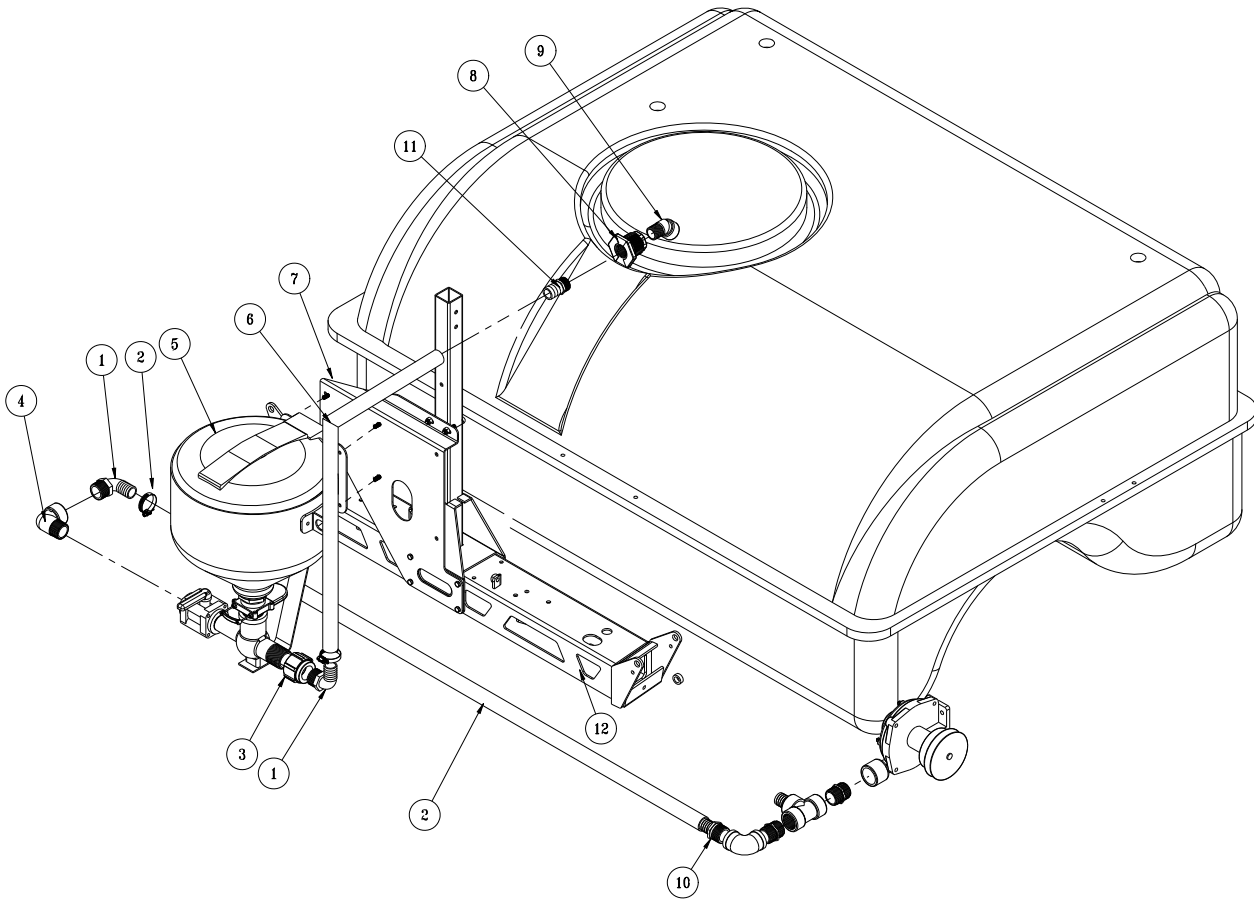

REF#	PART #	DESCRIPTION	QUANTITY
1	16-156	Elbow	2
2	8897-125	1 1/4" Discharge Hose x 125"	1
	18-116	Hose Clamp	2
3	18-391	Coupling	1
4	16-972	90° Elbow	1
5	15-620	Clean-load Assembly	1
6	8897-43	1 1/4" Discharge Hose x 43"	1
	18-116	Hose Clamp	2
7	17-635	Clean Load Mount (part of boom)	1
8	16-945	Fitting (part of tank)	1
9	16-971	45° Elbow (part of tank)	1
10	16-161	Fitting	1
11	16-159	Hose Barb	1
12		Center Boom	

## START-UP

1. All Clean-load valves must be closed prior to starting: inlet ball valve, knife valve and hopper rinse ball valve.
2. Open lid to check for foreign objects which may hinder performance or contaminate the system.
3. Close and lock lid by turning cover clockwise.
4. Divert pump flow to Clean-load inlet line. A pressure of 30 PSI minimum and 150 PSI maximum must be used. Highest pressures increase education rate and available wand suction.
5. Turn inlet ball valve on (yellow handle).
6. Open knife valve, located on the bottom of hopper, by pushing handle in (red handle).
7. Unlock and open lid slowly by turning cover counterclockwise.

## LOADING LIQUID OR POWDERED CHEMICAL INTO HOPPER

8. Pour required amount of chemical into hopper. Avoid splashing liquids or powdered chemicals outside of hopper.
9. Rinse empty chemical containers if applicable. Place container opening over container rinse valve and press down. This will activate the rinse valve and rinse container.
10. Rinse Clean-load hopper. Close and lock lid by turning cover clockwise. Release the safety locking band on the hopper rinse ball valve and turn on for 20 seconds. Close ball valve and return locking band to locked position.
11. Open lid and inspect for chemical residue. Repeat step 10 as necessary.
12. Close knife valve by pulling red handle out towards you. Turn inlet (yellow handle) off.

## LOADING LIQUID AND/OR POWDERED CHEMICAL WITH SUCTION LANCE

**Note: Lance suction is dependent upon eductor pressure and flow. For best results, use highest pressure available up to 150 PSI maximum.**

8. Insert lance body with o-ring into eductor until the o-ring is sealed.
9. Use the free end of the lance to pierce bag or container to vacuum powdered or liquid chemical.
10. Rinse lance. Place lance end into a clean container of water to rinse lance assembly.
11. Remove lance body from eductor and drain any remaining fluid into hopper.
12. Close knife valve (red handle). Turn inlet valve (yellow handle) off.

## SHUTDOWN

1. Ensure that:
  - All valves are closed. Be sure to close knife valve first. (Close by pulling red handle out towards you.)
  - Chemical residue has been cleaned.
  - Hopper lid is closed and locked by turning cover clockwise.
2. Divert pump flow back to normal operation.

Symptom	Corrective Action
Low education rate	Check pump pressure and flow. Cleanload Eductor performance is based on flow and pressure to the system. Note requirements for high education rates.  Increase outlet hose size back to tank.
Plugged or clogged bottle rinse nozzle	Disassemble rotary portion of nozzle from lower valve assembly and back flush until nozzle ports are clear of debris.
Plugged or clogged tank rinse nozzle	Disassemble rotary portion of nozzle from NPT hose barb and back flush until nozzle ports are clear of debris. Remove screen and flush with water to clear away foreign material.
Fitting leaks	Check for cracks in fitting. Replace fitting if necessary.  Disassemble and add more joint seal in compound if leak occurs on threads.

# 15-620 CHEMICAL CLEAN LOAD® PARTS DRAWING

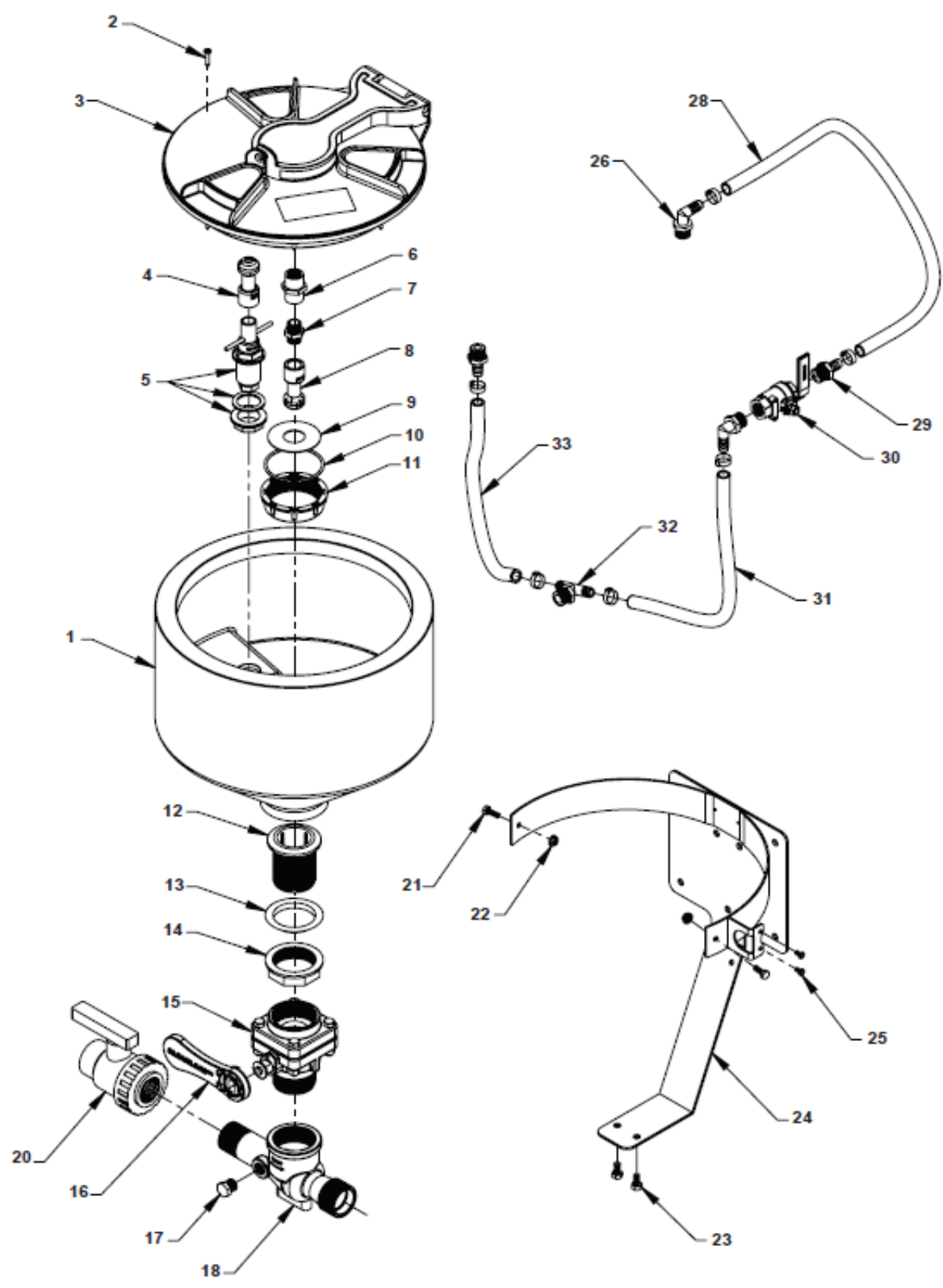

Accessories

## 15-620 CHEMICAL CLEAN LOAD® PARTS LIST

REF#	PART#	DESCRIPTION	QUANTITY
1	15-620-21	Tank	1
2		Screw, #6 x 1"	8
3	15-620-02	Tank Lid	1
4	15-620-22	ProClean Container Nozzle	1
5	15-620-23	ProClean Push Valve Assembly	1
	15-620-19	Tank Rinse	1
	15-620-20	Gasket, 1"	1
6		1/2 x 1/2 FNPT Coupler	1
7		1/2 x 1/2 Thread Nipple	1
8		ProClean Tank Wash Nozzle	1
9		Splash Retainer	1
10		O-ring Breather	1
11		Nut, Breather	1
12	15-620-18	Drain Head, 2"	1
13	15-620-17	Gasket, 2" Tapered	1
14	15-620-16	Locking Ring, 2"	1
15	15-620-12	Ball Valve	1
	15-620-15	Gasket, 2" BSP	1
16	15-620-13	Handle, Clean-load	1
17		1/2 MNPT PP Hex Plug	1
18	15-620-04	Clean-load Eductor	1
20	15-620-14	Ball Valve, 1 1/4 Single Union	1
21		Screw	2
22		Flange Nut	2
23		Hex Head Screw	2
24	15-620-01	Frame, Back Mount	1
25		Phillips Head Screw	2
26	15-620-11	Elbow 1/2"	2
28	15-620-08	Hose, Tank Rinse, 1/2" EPDM	1
29	15-620-09	HB, 1/2 MNPT x 1/2 HB	2
30	15-620-10	Valve, SS Tank Rinse	1
31	15-620-06	Hose, Valve Feeder, 1/2" EPDM	1
32	15-620-05	HB Tee, 1/2 MNPT to 1/2 HB	1
33	15-620-07	Hose, Bottle Rinse, 1/2" EPDM	1

# 15-835 TANK RINSING SYSTEM

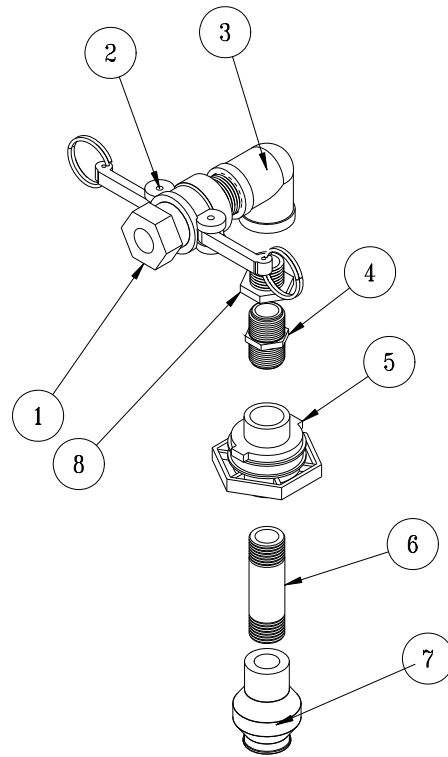

REF#	PART#	DESCRIPTION	QUANTITY
1	16-961	1" Adapter	1
2	16-962	1" Coupler	1
3	16-864	1" FTP Elbow	1
4	16-158	Close Nipple	1
5	16-150	Double Thread Fitting	1
6	16-172	4" Nipple	1
7	15-834	Tank Rinsing Nozzle	1
8	16-163	Reducer Bushing	1

Drill 1-3/4" hole 5" from outside edge of cover.  
 Install Tank Rinsing kit as shown, with the Double  
 Thread Fitting (Ref 5) going into the cover.

Basket Must be removed During Use.

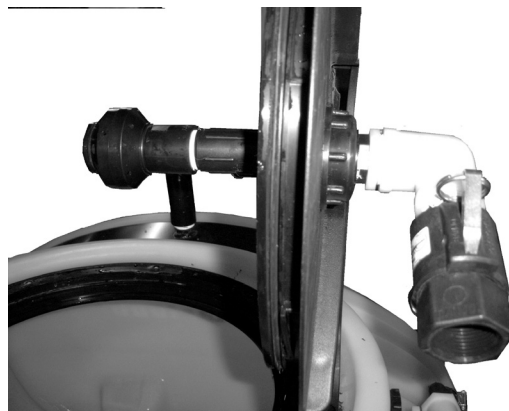

## DECAL LIST

This is a list of decals located on the Spray Star 3180. Part number, description and location will help in reordering decals.

A	15-463	Decal, Spray Pump
B	16-228	Decal, Over the Road towing
C	25-277	Decal, Battery Warning
D	25-279	Decal, Safety Warning
E	25-286	Decal, Pinch Point
F	25-298	Decal, Warning Hot
G	30-307	Decal, Refuel w/ Gasoline
H	25-356	Decal, Tire Pressure 20psi
J	25-372	Decal, 4" Star
K	25-370	Decal, 88 dBA
L	25-380	Decal, Tire Pressure 30psi
M	27-077	Decal Smithco
N	27-093	Decal, Hydraulic Oil Level
O	30-016	Decal, Spray Star 3180
P	30-320	Decal, Dashboard
Q	30-019	Decal, Site Gauge
R	30-331	Decal, Control Panel
T	34-147	Decal, Smithco Logo
U	25-387	Decal, Agitation
V	14-803	Decal, Clean Agitation Line Strainer

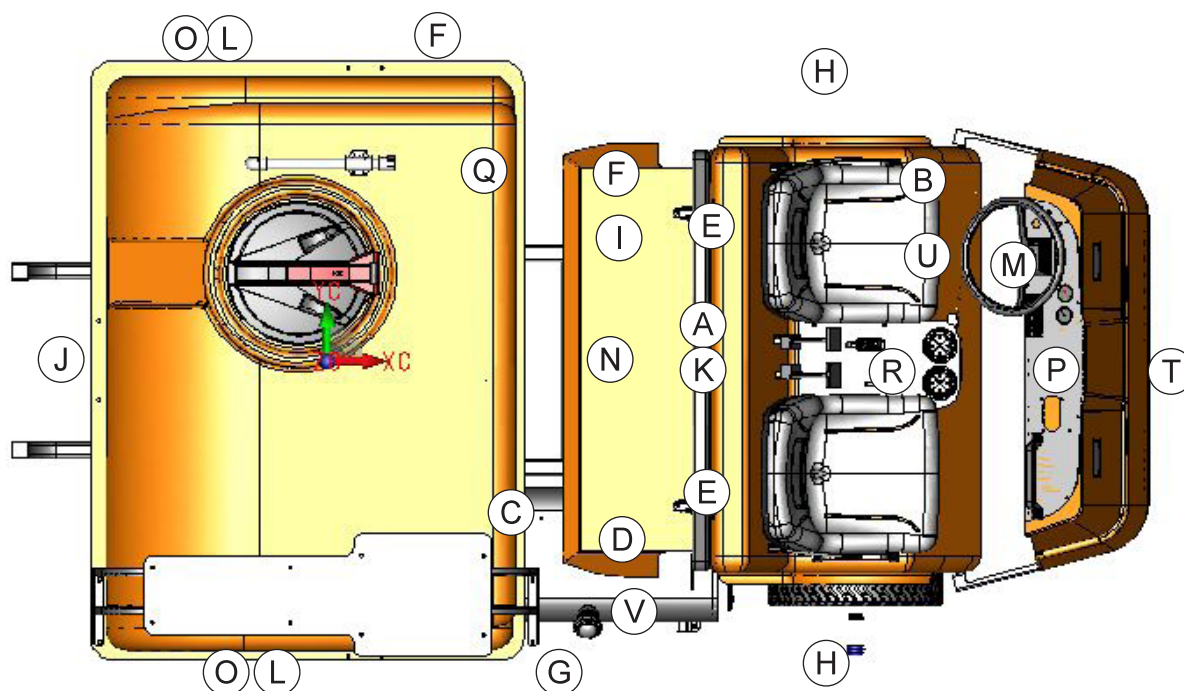

# QUICK REFERENCE REPLACEMENT PARTS

## REPLACEMENT FILTERS

72-146	Hydraulic Oil Filter Assembly
60-334	Replacement Element
32-521-07	Primary Air Filter
32-521-08	Secondary Air Filter
13-488	Key Switch
32-521-04	Fuel Filter Assembly
30-042-09	Cartridge Oil Filter
32-521-05	Muffler Gasket

## REPLACEMENT BELTS

30-197	Spray Pump V-Belt
30-042-11	Fan Belt

## SEAL KITS

15-301	Power Steering Orbital Motor
15-301-01	Seal Kit
30-101	Wheel Motors
30-101-11	Seal Kit
30-102	Hydrostatic Pump
33-058-01	Seal Kit
76-197	Gear Pump
76-197-08	Seal Kit
15-839	Hydraulic Cylinder (steering)
14-531	Seal Kit

## FLUIDS

Engine Oil	SAE 10W-40 API Service SJ or higher Motor Oil
Hydraulic Fluid	SAE 10W-40 API Service SJ or higher Motor Oil
Radiator	1.06 Gal 50/50 Antifreeze/water mixture

## OTHER PARTS

15-818	#75 Fitting O-ring
15-817	#50 Fitting O-ring
16-953	Hinged Cover On Tank with Gasket
16-953-01	Gasket For Cover
16-169	Strainer Basket
20-663	Tank Lid Gasket
20-593	Circuit Breaker 50Amp

# The Smithco Commercial Products Two-Year Limited Warranty

Smithco, Inc. (Smithco) warrants your 2016 or newer Smithco Commercial Product (“Product”) purchased after October 1, 2016 to be free from defects in materials or workmanship for the period of time listed below. Where a warrantable condition exists, Smithco will repair the Product at no cost to you including diagnosis, labor (at the Smithco standard labor rate, subject to the Smithco flat rate schedule), and parts.

## Warranty Duration is:

- (1) Two years, 1500 operational hours\* from the date of delivery to the original purchaser or Five years from the date of original manufacturer of the product, whichever occurs first. (\*Products equipped with hour meter).
- (2) Products used in rental situations are covered for 90 days from date of delivery to original user/renter.

## Owner Responsibilities:

As the Product owner, you are responsible for required maintenance and adjustments stated in your Owner’s Manual. Failure to perform required maintenance and adjustments can be grounds for disallowing a warranty claim. **You are particularly responsible to train all present and future operators of this product on the safe operation of this product at your location.**

## Instructions for Obtaining Warranty Service:

You are responsible for notifying the Authorized Smithco Products Distributor from whom you purchased the Product as soon as you believe a warrantable condition exists and not later than 30 days from discovery of the condition.

If you need help locating an Authorized Smithco Distributor, or if you have questions regarding your warranty rights or responsibilities, you may contact us at:

Smithco Product Support Department  
200 West Poplar Ave.  
Cameron, Wisconsin 54822  
Telephone: 800-891-9435 E-Mail: [ProductSupport@Smithco.com](mailto:ProductSupport@Smithco.com)

## Maintenance Parts:

Parts scheduled for replacement as required maintenance (“Maintenance Parts”), are warranted for the period of time up to the scheduled replacement time for that part.

## Items/Conditions Not Covered:

Not all product failures or malfunctions that occur during the warranty period are defects in materials or workmanship. The items/conditions listed below are not covered by this warranty:



Product failures which result from the use of non-Smithco replacement parts, or from installation and use of add-on, modified, or unapproved accessories are not covered.



Product failures which result from failure to perform required maintenance and/or adjustments are not covered.



Product failures that result from operating the Product in an abusive, negligent or reckless manner are not covered.



This warranty does not apply to parts subject to consumption through use, unless found to be defective. Examples of parts which are consumed, or used up, during normal Product operation include, but are not limited to: blades, tines, teeth, scarifiers, rakes, plates, wear plates, castor wheels, tires, batteries, filters, belts, nozzles, etc.



This warranty does not apply to failures caused by outside influence. Items considered to be outside influence include, but are not limited to, weather, storage practices, contamination, use of unapproved coolants, lubricants, additives, or chemicals, etc.



This warranty does not apply to normal “wear and tear” items. Normal “Wear and Tear” includes, but is not limited to, damage to seats due to wear or abrasion, worn painted surfaces, scratched decals or windows, etc.



Smithco may require the return of failed parts or components in order to determine the validity of any warranty claim.



Smithco will not be obligated to replace components of other manufacturers if inspection by the original component manufacturer indicates that failure was due to normal wear and tear, expected consumption through use or improper care or service.

#### **Other Legal Disclaimers:**

The above remedy for product defects through repair or replacement by an authorized Smithco distributor or dealer is the purchaser’s sole remedy for any defect. This warranty gives you specific legal rights, and you may also have other rights which vary from state to state.

**THERE ARE NO OTHER EXPRESS WARRANTIES OTHER THAN THOSE SET FORTH ABOVE. ALL IMPLIED WARRANTIES OF MERCHANTABILITY AND FITNESS FOR USE ARE LIMITED TO THE DURATION OF THE LIMITED WARRANTIES CONTAINED HEREIN.**

Some states may not allow limitations on how long an implied warranty lasts, so the above limitation may not apply to you.

**THE SMITHCO COMPANY IS NOT LIABLE FOR INDIRECT, INCIDENTAL OR CONSEQUENTIAL DAMAGES IN CONNECTION WITH THE USE OF THE PRODUCT, INCLUDING ANY COST OR EXPENSE OF PROVIDING A SUBSTITUTE PRODUCT OR SERVICE DURING PERIODS OF MALFUNCTION OR NON-USE.**

Some states may not allow the exclusion of indirect, incidental or consequential damages, so the above exclusion may not apply to you.

**Smithco neither assumes, nor authorizes any person to assume for it, any other liability in connection with the sale or use of this product.**

